

\$15.00

The Construction Of



SECRET
HIDING
PLACES

By Charles Robinson

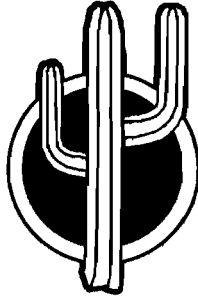

Desert Publications

A division of the Delta Group, Ltd.

P.O. Box 1751
215 S. Washington
El Dorado, AR 71731-1751 U. S. A.

IS



9 780879 474362

The Construction Of *SECRET HIDING PLACES*

By Charles Robinson

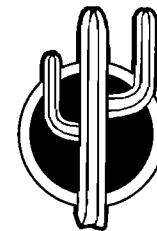
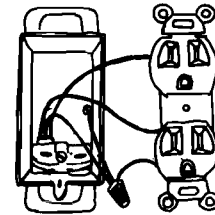

Desert Publications
El Dorado, AR 71731-1751 U. S. A.

The Construction of Secret Hiding Places

by
Charles Robinson

© 1981 by Desert Publications
215 S. Washington Ave.
El Dorado, AR 71730 U. S. A.
1-800-852-4445
info@deltapress.com
Printed in U. S. A

ISBN 0-87947-436-X
15 14 13 12 11 10 9

Desert Publication is a division of
The DELTA GROUP, Ltd.

Direct all inquiries & orders to the above address.

All rights reserved. Except for use in a review, no portion of this book may be reproduced by any means known or unknown without the express written permission of the publisher.

Neither the author nor the publisher assumes any responsibility for the use or misuse of the information contained in this book. This material was compiled for educational and entertainment purposes and one should not construe that any other purpose is suggested.

Warning!!

The Publisher (Desert Publications) produces this book for informational purposes and under no circumstances advises, encourages or approves of use of this material in any manner.

Table Of Contents

Introduction	1
1. Putting "Dead Space" To Work	3
2. Standard Hardware, Molding Aids	9
3. The Electric Outlet Stash	13
4. Hiding Flat Objects	15
5. Kitchen Supply Hiding Places	19
6. Hiding Places In Everyday Objects	23
7. Hide It In A Door	27
8. Behind The Medicine Chest	31
9. Plumbing Can Hold More Than Water	33
10. Stashes In & Behind Molding	37
11. Gun & Hat Rack Stashes	39
12. A Stairway To Secrecy	43
13. Secret Compartments Behind Shelves	45
14. Kitchen Cabinetry Stashes	47
15. Secret Rooms & Panels	51
16. Heating & Cooling Vents	57
17. Windowsills & Brickwork	59
Questions & Answers	61

List Of Illustrations

Figure 1.	Cutaway View Of Typical Wall Construction	4
Figure 2.	Wall Stash Between Uprights	5
Figure 3.	Typical “Dead Space” Hiding Areas	6
Figure 4.	Common Hinges And Fasteners For Hiding Places	10
Figure 5.	Most Common Moldings	11
Figure 6.	Wall Socket And Junction Box	14
Figure 7.	False Bottom Drawer	16
Figure 8.	Detergent Box Stash	20
Figure 9.	Home “Canning” Stash	21
Figure 10.	Hollow Shoe Heel	24
Figure 11.	Hidden Stashes In Everyday Objects . .	25
Figure 12.	Hiding Space Inside Door	28
Figure 13.	Full Length Wall Or Door Mirror Stash	29
Figure 14.	Opening For Countersunk Medicine Chest	32
Figure 15.	Common Plumbing Stashes	34
Figure 16.	Doorway Molding	38
Figure 17.	Hat Or Gun Rack Stash Cover	40
Figure 18.	Typical Stairway Construction	42
Figure 19.	Hiding Place Behind Removeable Shelves	44

Figure 20.	Backboard, Outside Frame And Revolving Door	44
Figure 21.	Overhead Kitchen Cabinet Construction	46
Figure 22.	Removeable Kickboard	49
Figure 23.	Removeable Splashboard	50
Figure 24.	Shelves Concealing Door To Secret Room	52
Figure 25.	Shelves Concealing Crawl Space To Secret Room	53
Figure 26.	Secret Panel In Closet Under Stairway	54
Figure 27.	Typical Wall And Ceiling Duct Vents	56
Figure 28.	Removeable Windowsill	58
Figure 29.	Brick Hiding Places	60

Dedication

Lenny's girlfriend yelled, "It's the cops!" Lenny had been arranging the contraband just smuggled in from Europe. He was in his secret room built under the back stairs. He was sitting on top of enough hash to get twenty years. Lenny knew that the cops had been tipped and they knew what was there. A team of State Troopers tore the house apart looking for what they figured to be one of their biggest busts. Three hours later they left in disgust, without the goods and without Lenny. They were outdone.

Bryan dealt in jewelry. While he was gone for the weekend someone broke into his apartment and did a thorough search. The place was a mess—but the gold, silver, gems and jewelry were right where he left them, inside the bathroom door.

Robin always carried a gun with him when he went into the city. That place was a jungle. It was just a small automatic and while driving he kept it in its secret compartment in his '67 VW. He parked the car and ran into a restaurant for a quick bite. Wouldn't you know it, the New York City Police towed his car away. They made it a policy to search all cars towed in. They also had the toughest gun law in the country. Robin bailed his car out for fifty dollars—no problem.

This book is dedicated to them—and you.

Introduction

Almost everyone has some reason to hide something. Sometimes there is jewelry, seldom used but of sentimental value. A gun for self protection—in New Jersey where this is being written, it's easier to get an “illegal” gun than it is to get a “legal” one—so much for a commentary on gun control. Lots of folks don't trust banks anymore—the word “bank” by the way is derived from riverbank where people use to hide their money. In Russia right now they hide Bibles.

There are basically three types of people that you may be in need of securing your valuable items from. Type one is the amateur petty thief. This low life type works basically on opportunity. A door left open, something left lying around.

Type number two is the professional thief. This one plans his jobs well. He knows what he wants—exactly—and usually where it's kept. He usually keeps track of people's schedules and plots them and if he doesn't find what he thinks or knows is there he's likely to do a fairly thorough and methodical search.

Type three, is probably the most dangerous adversary that it is possible for you to cross paths with. Type three is an agent of the state. It is possible for this type to gain permission and muscle to poke his nose anywhere he likes. His power of search is legally restricted but once granted he literally has *carte blanche*.

All methods of building secret hiding places revealed in this book were chosen for the ability to be readily adapted to

different situations and in different and individual ways. The majority have been proven in actual situations and under actual and not simulated conditions, with the unwitting assistance of types one, two and three.

1. Putting "Dead Space" To Work

Well, we have to begin somewhere, where shall it be? The first thing that I have to do is to make some assumptions about your store of knowledge. I have to go on the premise that you do have some building skills and access to very basic carpentry tools. In each area I have to assume that you have knowledge of what is involved. If not, the local library can provide you with plenty of additional "conventional" knowledge. I've arranged the book so it will flow from the simple to the more complex. This usually means from the smaller secret hiding places to the larger ones. There are a lot of gray areas however so you will find some deviation.

Before we begin, a word of caution. Don't go pulling your house apart as soon as you put down the book. Make sure you know what you're doing. Remember, measure twice, cut once. Also, one well-built secret hiding place is worth ten sloppy jobs. If you're going to do something, do it well.

Very basically, the construction of secret hiding places is nothing more than the utilization of "dead space" and suitable covering methods. Sometimes the "dead space" exists, sometimes the "dead space" is created. The choice of space and method to use will be determined by what you want to conceal. The choice will obviously not be a secret room if you only want to hide a valuable postage stamp.

Walls are constructed of sheetrock and 2x4's. The 2x4 beams run vertically from floor to ceiling and are spaced 16 inches apart. The sheetrock is nailed to the beams and presto,

SECRET HIDING PLACES

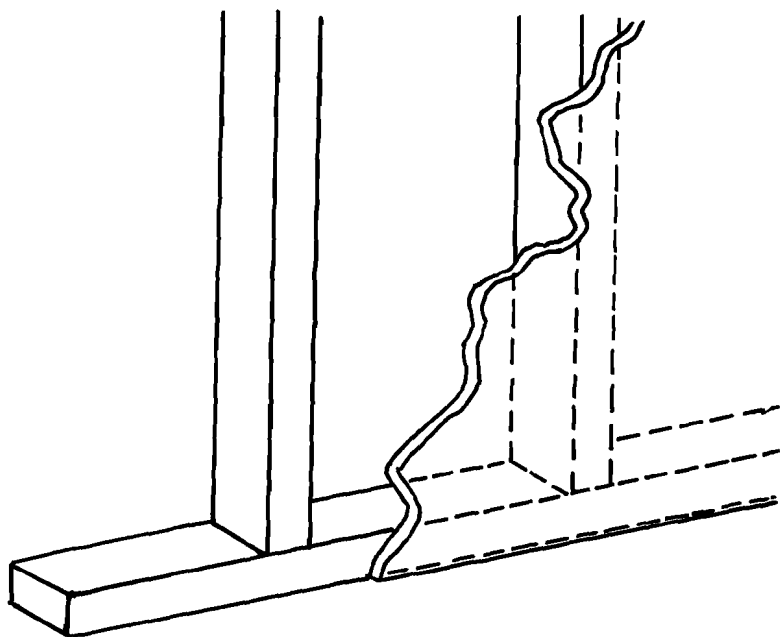

Figure 1.
Cutaway View Of Typical Wall Construction

you have a wall once the cracks are filled in with tape and spackle. If you tap along the wall you'll be able to find the beams and the dead space between the beams with very little practice.

Figure 1 shows a cutaway view of typical wall construction.

Obviously, there's an incredible amount of space that can be used within your walls. Figure 2 shows a wall where two sections between the beams have been cut away to provide for a suitable stash. An important thing to remember is that the hole you cut in the wall must be smaller than the object used to cover it. For example, if you're planning a project like a gun rack that's 36 inches by 12 the hole would allow

SECRET HIDING PLACES

for several inches on each side. Because the space in the wall extends from the ceiling to the floor you might want to line the space by building shelves, etc., inside. This allows for a secret hiding place within the secret hiding place if desired.

Figure 3 shows a typical closet under stairs and a typical kitchen cabinet arrangement. The arrows point to built in "dead space". Often above kitchen cabinets the wall will be extended to meet the ceiling for appearance. This is a very large dead space that attracts no attention and is thus well

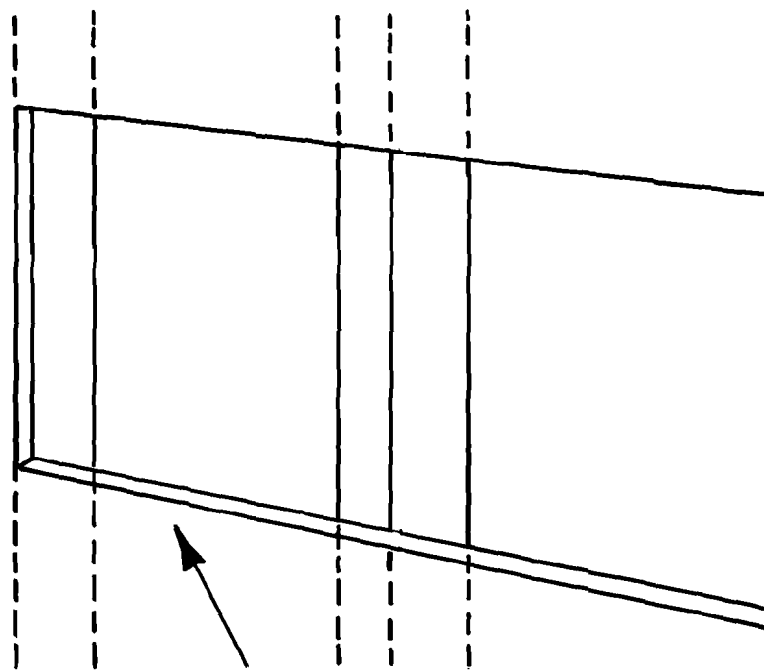

CUT ONE OR MORE SPACES BETWEEN 2x4 WALL STUDS.
COVER WITH GUN RACK, COAT RACK, ETC.

Figure 2.
Wall Stash Between Uprights

SECRET HIDING PLACES

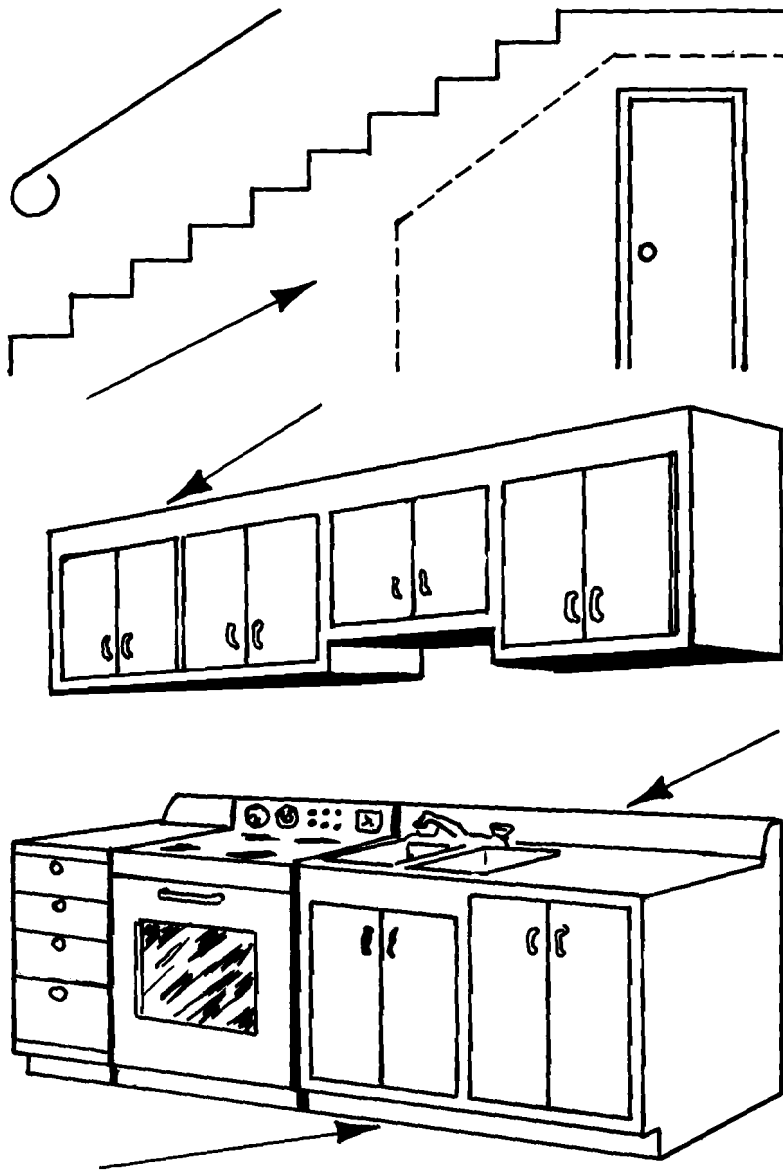
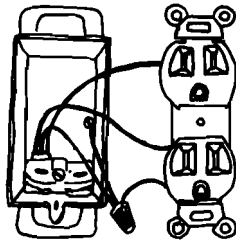

Figure 3.
Typical "Dead Space" Hiding Areas

SECRET HIDING PLACES

suiting for our purpose. Also the splash board and kick board on the bottom cabinets provide suitable space and easy access. Plans for all three are provided later in this book.

The point that I am trying to make by bringing up these illustrations is that whoever built the place in which you now live included a tremendous amount of dead space. By looking around your house you'll be able to find all the space you need.



2. Standard Hardware, Molding Aids

Figure 4 shows some typical items of hardware that are most useful in the construction of secret stashes. Tension springs can take several forms and are used to keep secret panels and flaps closed. Likewise magnetic and friction snap fasteners as found on cabinets are quite useful. There are many types of hinge arrangements, most of which I'm sure you're familiar with. The Soss hinge is one type of invisible hinge but there are several other types on the market. Depending on what type of secret hiding place you decide to construct, you might want to use fake nails, screws, etc. One item that comes in really handy is velcro. Velcro is the material used on ski jackets, shoulder holsters, etc., that sticks together and holds very strongly. It's also used on the arm band the doctors use around your arm when taking your blood pressure. The best thing to do is to take a trip to a hardware store that specializes in hardware for cabinet makers. That way you can get to know what is available in your area, get hands-on experience by seeing with your hands as well as your eyes, and maybe even get to talk shop with some of the guys there.

Well, just one more thing to go over lightly and then we'll get down to business. Figure 5 illustrates the six most common types of molding that you'll run across. Type 1 is panel molding that is most often found in older dwellings with wood paneling. Second is chair rail molding. If you have this in your kitchen, fine, if not it can be easily added with a con-

SECRET HIDING PLACES

TENSION SPRING



MAGNETIC FASTENERS

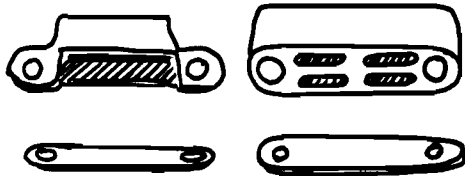

FAKE NAIL



SOSS HINGE

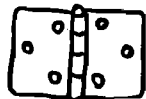

VELCRO



FRICTION CATCH

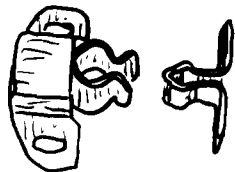

Figure 4.
Common Hinges And Fasteners For Hiding Places

SECRET HIDING PLACES

cealed space behind, of course. Third is apron molding found around doors, windows, etc. Fourth is baseboard molding. Shoe molding is fifth – this is particularly handy for concealing hinges if, by necessity, hidden hinges can't be used. Sixth and last is the saddle molding used in doorways.

Molding is used for basically two purposes, to create a trim and to conceal imperfect cuts. We can use it to conceal other things as well.

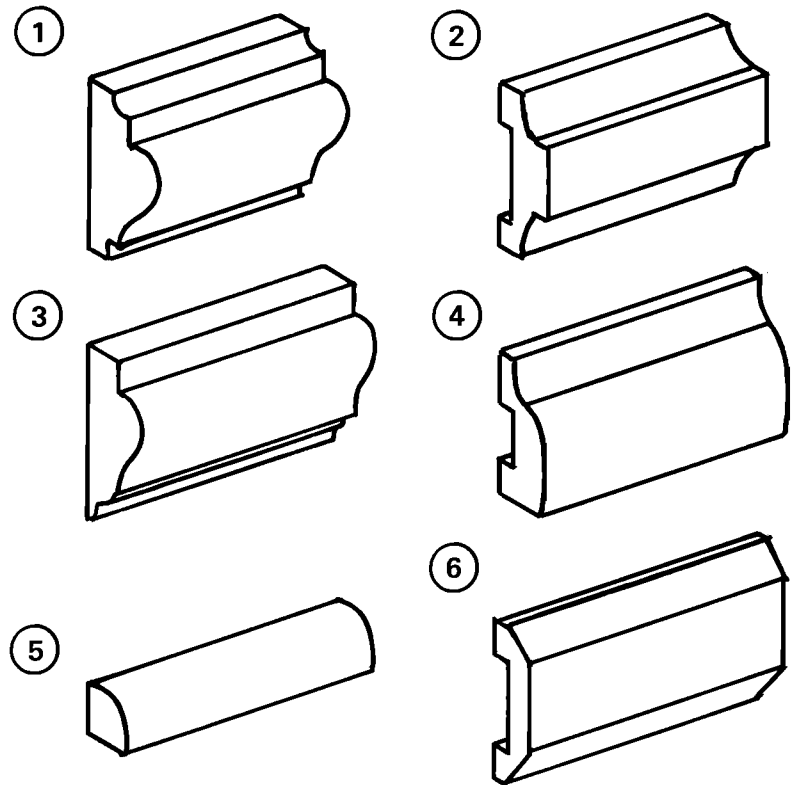

Figure 5.
Most Common Moldings

3. The Electric Outlet Stash

The first stash and the easiest deals with electric outlets. There are phony ones on the market but they're a waste of money. Use what you have.

The first thing to do when working with electricity is to make sure the power is off. Do this by removing the fuse or throwing the circuit breaker to the off position.

All electrical switches, outlets, etc., are set in junction boxes. When you remove the cover plate you'll see the box. Simply disconnect the wires after removing the switch or plugs, insert the object you wish to hide, reconnect the wires and replace the plate. A word of caution. When hiding an object that is capable of conducting electricity, be sure to insulate it prior to placing it in the junction box, use several baggies, plastic wrap, electrical tape, etc. Figure 6 shows a typical wall socket.

Once you have your item safely stashed, turn on the juice and everything's back to normal.

One variation that is favored by gem dealers for long term storage is in ceiling light fixtures found in most kitchens and dining rooms. Simply remove the fixture, stash the item, and put things back the way you found them.

Most people have a healthy respect for electricity and this is for good reason. If you don't know what you are doing, don't do it. If you have the knowledge to work with live juice, fuse or circuit breaker boxes offer much greater capacity than sockets, but remember, if you don't know what you're doing

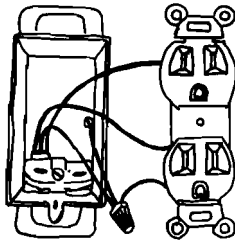

—live juice can do you in. Once again I must repeat be sure to insulate objects hidden in electrical boxes and make sure you know what you're doing.

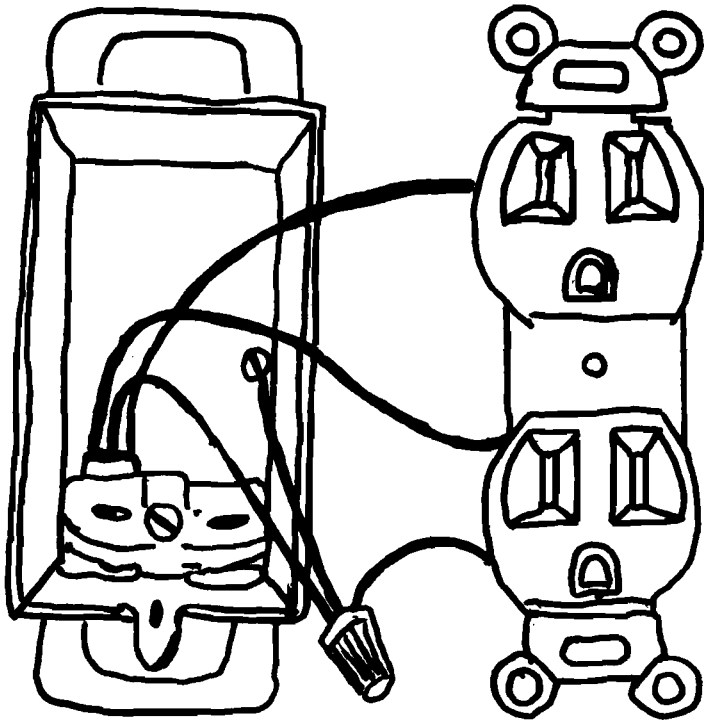

Figure 6.
Wall Socket and Junction Box

4. Hiding Flat Objects

One of the safest methods to hide money, documents and microfilm expediently is to use pictures of the family, diplomas, etc., and use the space between the picture and the rear liner. Any framed object of no value to anyone but the owner serves well. It makes it easy to keep an extra four or five thou around too.

Well, while we're on the subject of slim spaces it's appropriate at this time to cover false bottom drawers, trunks, etc.

Now, it's very important that if you're doing false bottom drawers that all the drawers in a given piece of furniture are identically matched. With a false bottom trunk there is no problem but with false bottom drawers you may have to do the whole set. The first thing that must be done is to cut a liner from suitable material. The cut must of necessity be exact—remember, measure twice, cut once. Things cannot look altered, so get the same kind of wood. If this is not possible you may have to paint the entire piece. In a pinch it is sometimes possible to use what is already there and simply construct a new bottom of the drawer. Usually the simpler methods are the best.

Figure 7 shows an empty, altered drawer (top), its false liner (center) and a side view of the completed hiding place (bottom). The alteration to the drawer is that five washers have been glued to the real bottom of the drawer, one in the center and one in each corner. Additional washers may be stacked to the desired height, then glued together. Washers

SECRET HIDING PLACES

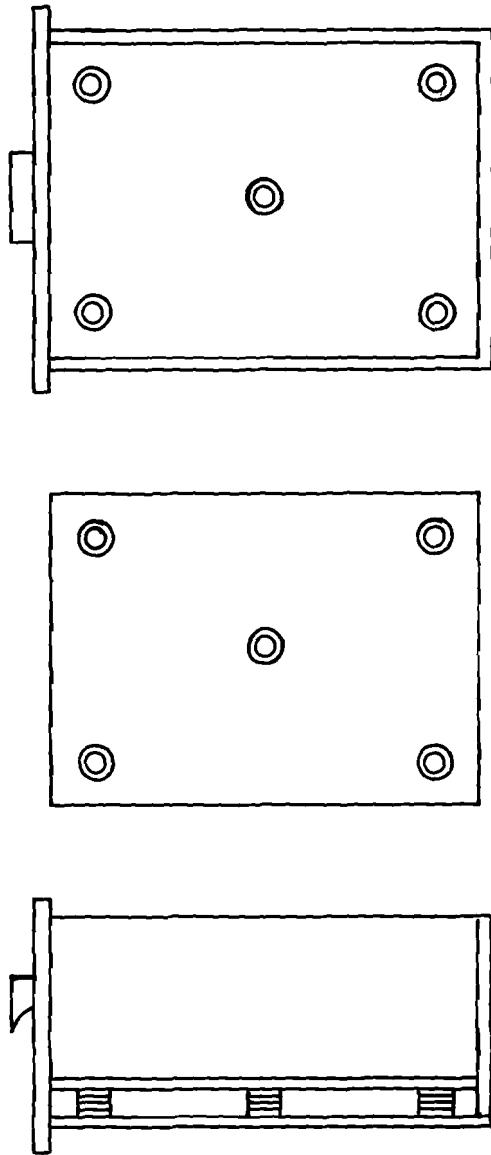

Figure 7.
False Bottom Drawer

SECRET HIDING PLACES

should also be glued to the bottom of the false drawer bottom, their locations corresponding to the washers on the real bottom. When the false bottom is inserted, the washers will line up and will create a custom-fitted compartment of the desired thickness. Of course, the compartment should be kept thin to avoid detection and can be used to hide thin items only.

By use of magnets the lining can be lifted in and out. Other methods include the use of velcro strips. A hole in the bottom of the drawer the diameter of a pen will be sufficient to enable the upside down drawer to accept the pen and pressure will open the compartment.

False bottom chests offer more space and have successfully been used by smugglers for years. Simply use the same method as outlined above. If you're concerned about metal detectors, use a metal trunk or non-metallic washers. With a trunk you can even go one step further and reline it with suitable material so that it looks original with a minimum of effort. Remember, pay attention to detail.

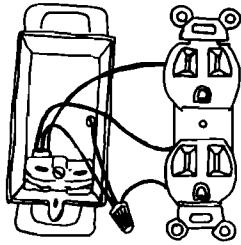

5. Kitchen Supply Hiding Places

The kitchen offers countless areas for secret hiding places. Before we get into the more advanced stashes let's cover some simpler but extremely effective ones.

With a little bit of practice you will be able to open and reseal cartons and cans so that even to the trained eye they will appear untampered with. One of the easiest to use is a box of laundry detergent. Having an extra one around draws no suspicion, has some natural heft to it, and is probably the last thing someone would want to steal. Let me tell you how to do it. First, select the box and don't even try to open it—until you turn it upside down. That's right, work from the bottom. It gives you that extra edge. In prying the flaps loose I prefer a large, sharp knife. Some people prefer putty knives. Experiment and find what's best for you. The whole idea is to cut as much of the glue and as little of the cardboard as possible. Once you've opened your stash, put what you want hidden inside and reseal.

The best glue for this purpose that I've found is either Elmer's or rubber cement. Remember to use the glue sparingly. At the factory the gluing is done by machine and it's worked out to use the minimum suitable amount. Once you have it glued, turn it right side up and place the box on a table or the floor for ten minutes. This will hold the flaps in position while it dries and also duplicate the pressure exerted at the factory.

SECRET HIDING PLACES

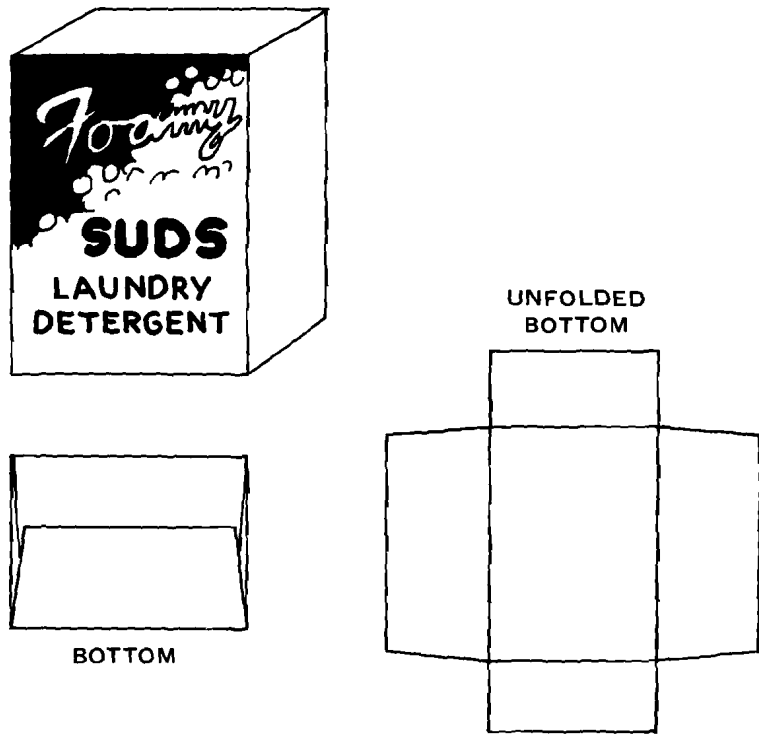

Figure 8.
Detergent Box Stash

Fake tin cans is another one that doesn't take much practice to become efficient, and there's always material to work with. When was the last time you paid any attention to a tin can? What a great place to stash something. Remember—all secret hiding places should draw as little attention as a tin can.

Here's how it's done. First select a can of something that no one would eat or want to eat. Say a can of dog food, for instance. Figure 9 shows the process. First remove the label and cut the can along the dotted line using a hack saw. Con-

SECRET HIDING PLACES

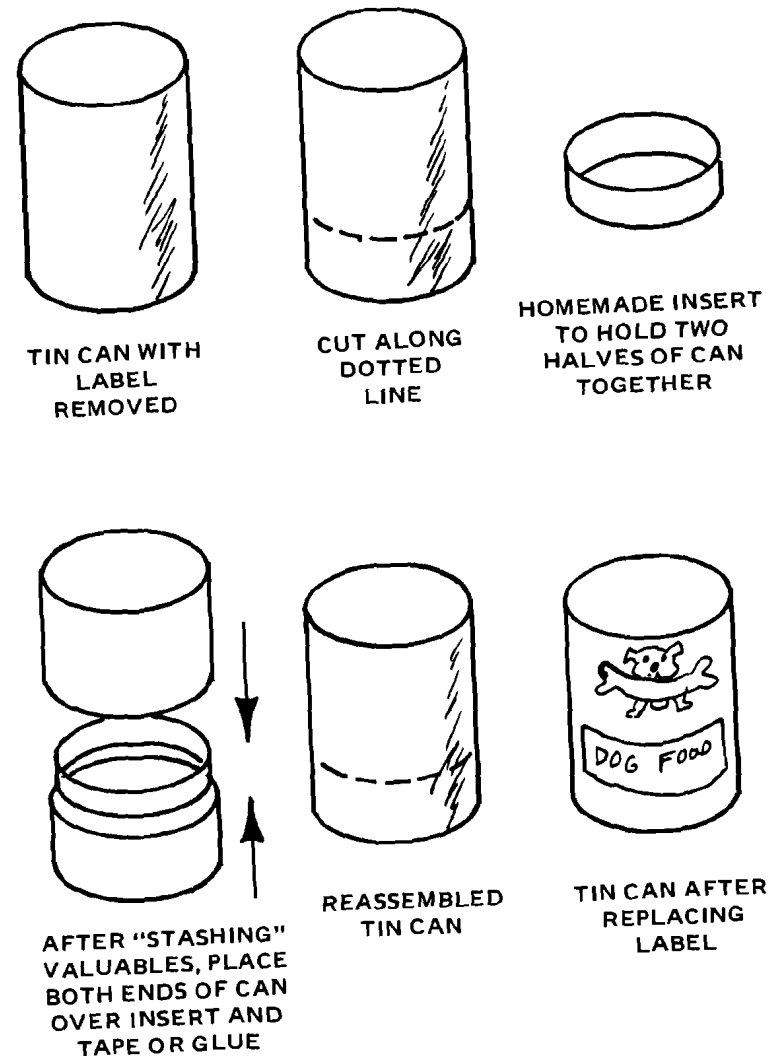

Figure 9.
Home "Canning" Stash

struct an insert to hold the two halves together and keep them aligned, put the three pieces back together with the object inside, use strong plastic tape along the crack, put the label back on and put the item back on the shelf. If you don't mind using a can opener to retrieve your item you can forget about the tape and use glue instead. That will prevent any play among the parts.

6. Hiding Places In Everyday Objects

Movies often give the wrong impression and certain things will be straightened out by the publication of this book. I'm sure you've probably seen in spy movies the fake shoe heel that swivels out. Very bad. Remember—keep it simple, don't create work for yourself. There's a much better way, enter from the top.

The simplest way to use a heel of a shoe is to lift up the heel pad from the inside of the shoe, hollow out an area using a drill and sharp knife. Insert the object, pad the remaining area and glue the flap back in place with rubber cement. If you have a pair of old shoes that you've been meaning to get rid of, give it a try and see how easy it is. Once you've got it down you can do other shoes or if you're careful, you just may decide to keep that old pair of shoes a little longer.

Figure 10 shows a cutaway view.

Fake books are a snap. All that is required is a book and a knife. Cut out a suitable space to hold the object that you require, tape the compartment and you're in business.

This hollowing out technique can be taken further also. By using a drill you can hollow out legs of chairs and other furniture. The end can be covered by a skid plate and smaller objects, roles of money, etc., can be conveniently and safely stored.

Do you have an old set of crutches from a ski accident? Drill a hole in the end and replace the rubber cap. Who's

SECRET HIDING PLACES

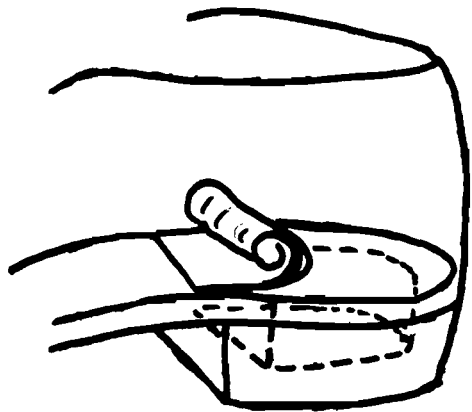
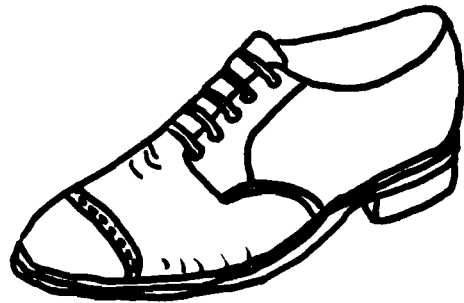

Figure 10.
Hollow Shoe Heel
(The simple way, not the movie way.)

SECRET HIDING PLACES

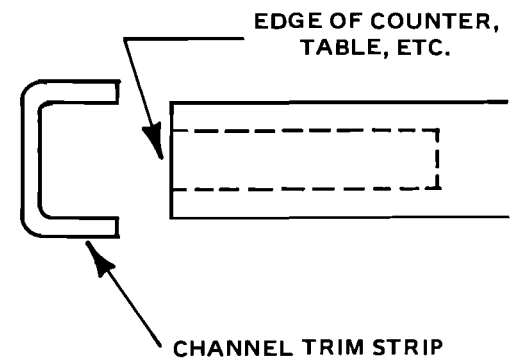
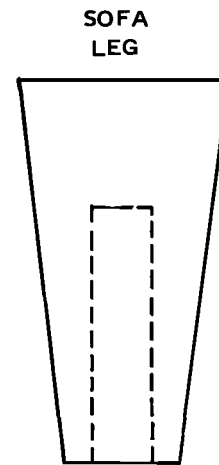
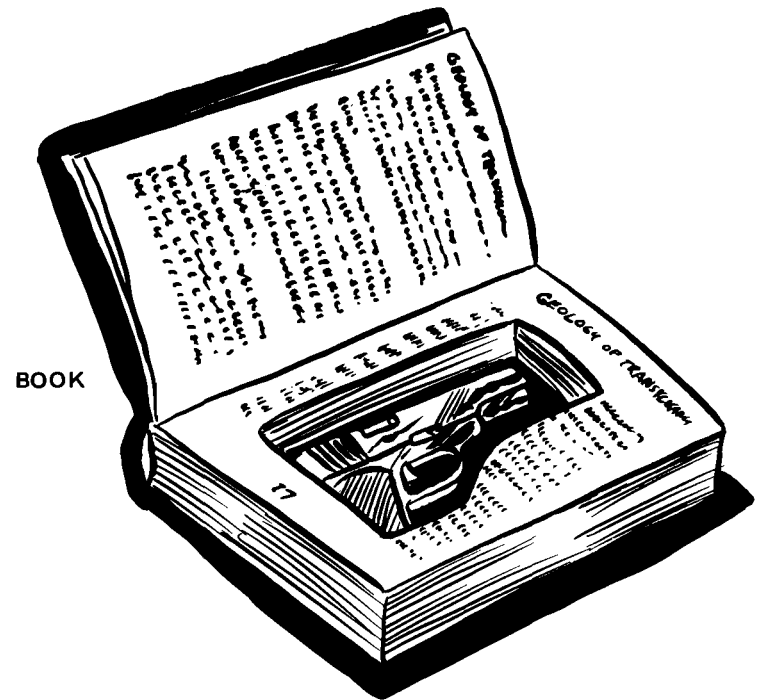

Figure 11.
Hidden Stashes In Everyday Objects

gonna even suspect? After all, if you saw a crutch, would you think someone had something of value stashed inside?

If you check out Figure 11 you'll see we've carried it one step further. By using your drill and a chisel you can hollow a space along the edge of a utility table and put channel trim along the edge. Use screws on the underside to hold it on.

7. Hide It In A Door

Figure 12 shows a variation of this type of stash that is highly accessible and well suited for small to medium sized objects. It is particularly good for small frame automatics. Simply hollow out a space along the top of a door by drilling and using a chisel. If you go out and buy a drill rasp you'll find it a good investment for this project. Custom size the space to whatever object you want to stash, build a lid to cover the opening and you're all set. The type of lid that I would suggest is one held on by small magnets inserted into the door and small thin pieces of sheet metal glued to the lid at corresponding intervals. The magnets will hold the lid firmly in place yet it can still be easily opened with a fingernail.

If ease of access is not of paramount importance you can be really slick by putting the stash at the bottom of the door instead of the top. If the door in use doesn't swing over stairs or some open space this will necessitate removing the door to get to the stash, but if you don't mind taking the door off the hinges at infrequent intervals, you might find this more to your liking.

As you are probably aware, most doors are hollow. We can also utilize that hollow space and also the space between the beams with the next stash, the sliding mirror stash. Mounted mirrors are secured by means of brackets. The most common arrangement is as shown in Figure 13. Mirrors such as illustrated lend themselves very well to doors, as well as

SECRET HIDING PLACES

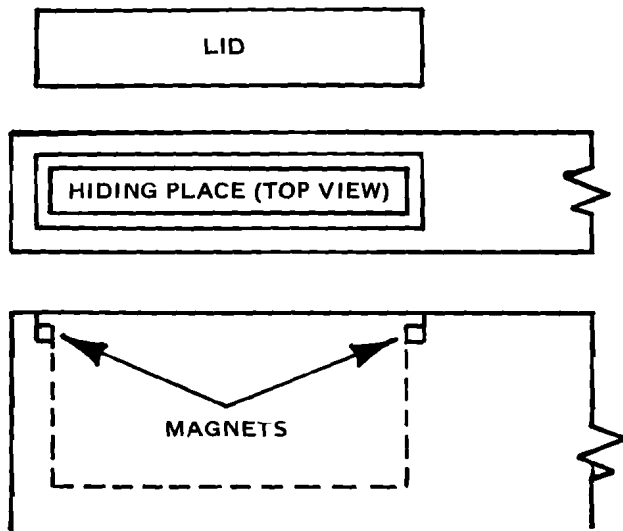

Figure 12.
Hiding Space Inside Door

bathroom and bedroom walls. If you stop in a store that sells mirrors you'll find a suitable arrangement of other types as well.

When you mount the mirror be sure to get several sets of extra brackets so when a pair shows wear they can be replaced. Keep the extra brackets in the secret hiding place to make it easier to keep track of them.

Pick the spot you wish to mount the mirror, cut a hole in the wall, line the hole with shelves or whatever else is necessary for what you have, mount the mirror, and you're set.

I highly recommend this as a first project. To reduce any marks that may occur on the wall from opening the stash, simply spray the back lightly (I said lightly) with silicone spray and/or make runners by using two rows of tape running vertically on the back of the mirror. Also loosen the side mounts somewhat before sliding upward.

SECRET HIDING PLACES

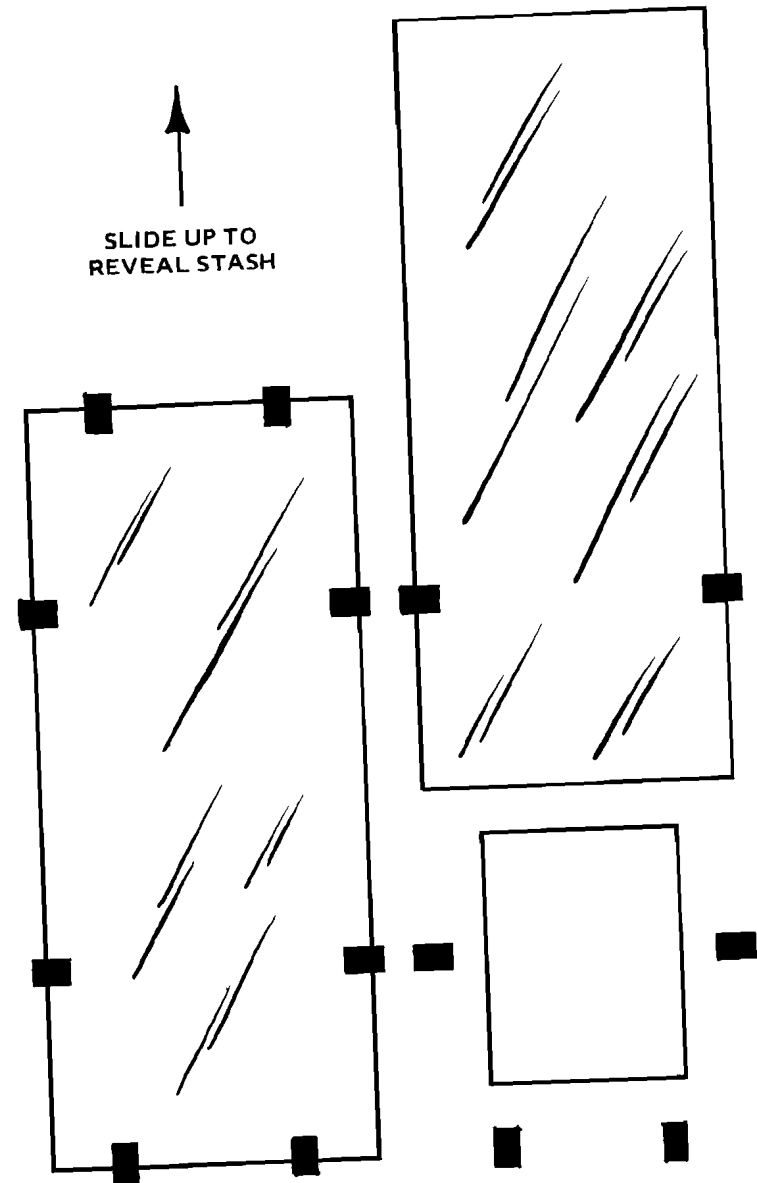
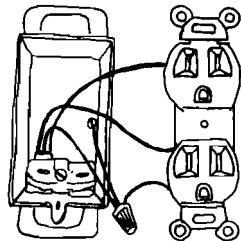

Figure 13.
Full Length Wall Or Door Mirror Stash



8. Behind The Medicine Chest

Did you ever wonder what's behind the medicine chest in the bathroom? Well, let me tell you, you've got a really great stash back there, that's what's there.

There are two kinds of medicine chests. One screws directly on to the wall, the other is countersunk. To remove the chest simply take off the doors, empty the chest and unscrew the screws. If your medicine chest screws onto the wall the screws will be located in the back. If the unit is countersunk into the wall, the unit will have screws in the side.

The models that are countersunk will already have a hole in the wall cut for you. With the kind that attaches directly to the wall you will have to cut a hole yourself. The best procedure for you to take is if your cabinet attaches *to* the wall, keep it. If the cabinet is countersunk *into* the wall, scrap it. The reason why is ease of access.

Obviously, a screwdriver will be needed for gaining entry to this secret hiding place. Plus you'll have to move some junk to clear it out before removing. By only using the type of chest that attaches *onto* the wall you can make accessibility easier. Here's why. On the mounting holes that the screws go through, use your drill and a rat tail file to give it a key-hole shape with the smaller portion at the top. Do this carefully and camouflage the cuts so they look like factory work. This helps you remove and replace the cabinet faster and reduces wear on the screws because you will only need to loosen them by a short turn rather than remove them.

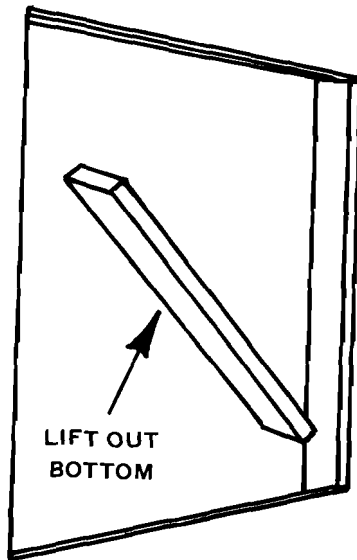

Figure 14.
Opening For Countersunk Medicine Chest

Figure 14 shows a typical hole in the wall as left by the removal of a cabinet that is countersunk. Note that a shelving arrangement has been built into the space and that the shelving is removable for what is, in effect, a stash within the stash. By using two angle irons the shelf is held in place and although it would be hard to pry it up because of the way it is situated, two rubber tipped darts, the kind that children play with will remove the board.

9. Plumbing Can Hold More Than Water

A little knowledge of plumbing can prove very useful. Figure 15 shows three variations. The first is a fake drain for the low end of a basement, commercial kitchen, etc. The other two are clean-out plugs, the larger one is a waste stack. If you look in your basement you'll find something quite similar.

With a little bit of knowledge, plumbing is easy to fudge and incredibly effective. Although each model stash illustrated is easy to open, people tend to have an aversion to putting their hands into pipes leading into sewer lines. If there is a knowledge of plumbing by your adversary he's certainly not going to risk coming up with a handful of something he's not particularly interested in and if your foe knows nothing of plumbing, he won't mess with the pipes either.

Make sure that you don't injure the nut when opening and closing the plugs that secure the secret hiding place. If you do there should always be enough dirt and dust close by to make things look right with a minimum of bother. If a spider wants to use part of the pipe run for a home, so much the better.

Because it's impossible for me to know the plumbing set-up in your house I'd strongly suggest going to your public library and getting a book on basic plumbing. Special care should be taken to insure that all your pipes in the basement look right with each other. Sometimes these projects do in

SECRET HIDING PLACES

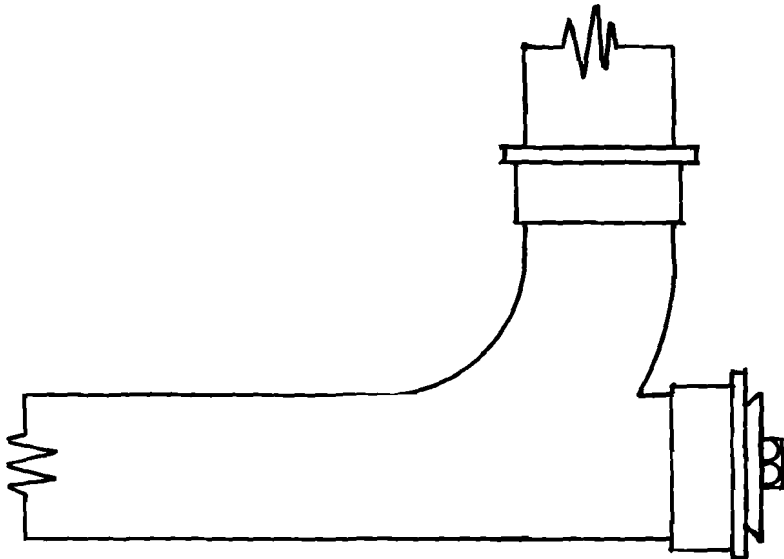
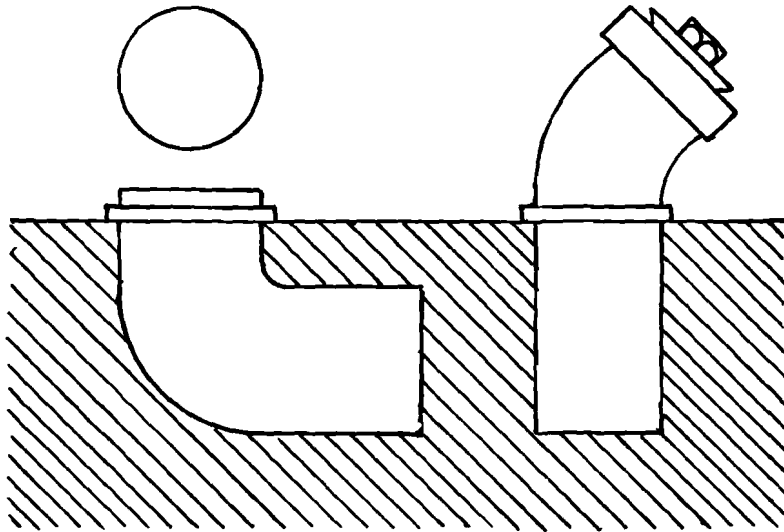

Figure 15.
Common Plumbing Stashes

SECRET HIDING PLACES

fact become larger than originally anticipated. For example, in digging a hole in which to construct a false drain it will be necessary to re-cement the basement floor as well as painting the entire floor to match. Always plan your work carefully to insure that you have the necessary knowledge and materials prior to starting. You'll save yourself a lot of time and inconvenience that way.

Plumbing stashes are among the best there are—especially if you're concerned with metal detectors. After all, what could be more natural than a metal detector going off around big cast iron pipes?

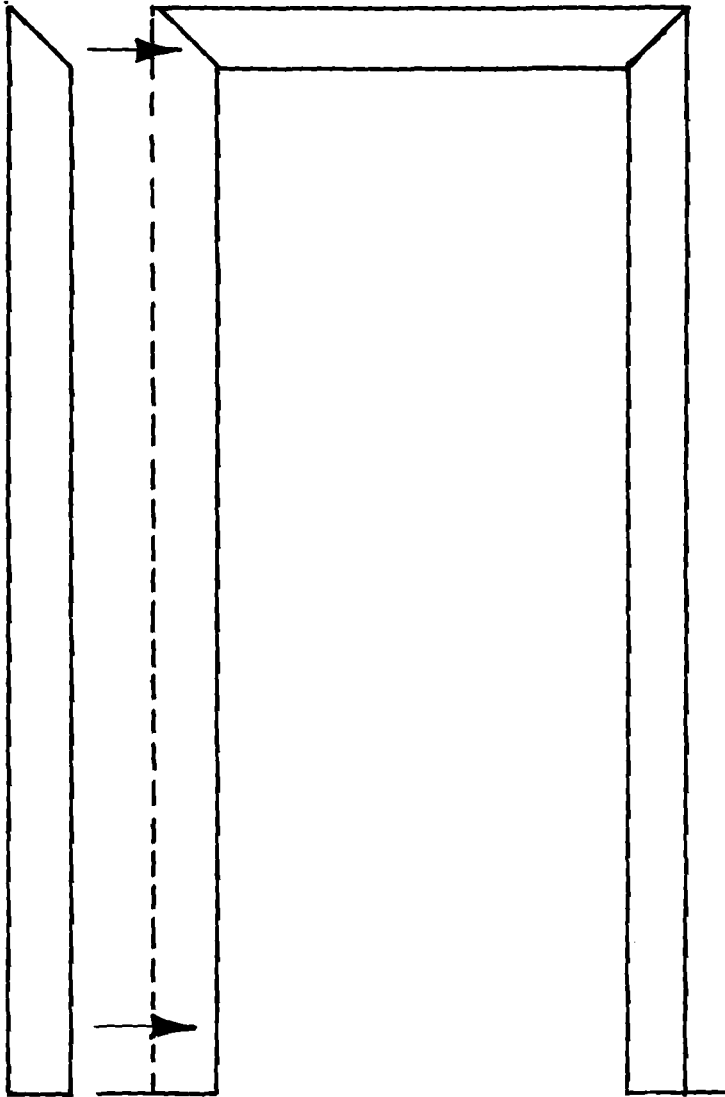

Figure 16.
Doorway Molding

10. Stashes In & Behind Molding

Molding is a cinch as long as you're careful. What's really great about molding is that it's everywhere. Just look around you. Doors, windows, floorboards, even in garages you'll find molding.

The technique is quite simple. Choose a run of molding that is suitable for your space requirement needs and that is also preferably in an out of the way place. Very carefully pry the molding loose without damaging the surrounding area. With the molding removed cut an area out that will fill your needs and replace the molding.

Fastening techniques run from just leaving the nails in and bending them slightly for pressure to hold the molding in place to snap friction fasteners, to velcro. Choose the method that best suits your needs.

An old friend of mine used to hide a shotgun in the molding by one of his doors. I knew him for three years before he showed me. In the meantime I had been through that door probably a hundred times and never even suspected what was hidden there.

11. Gun & Hat Rack Stashes

For a real custom secret stash project, a hat rack or one gun rifle rack is easy as pie and well worth the investment in time, material and labor.

Essentially the steps as shown in Figure 17 are as follows. First construct your hat rack, gun rack, etc. Before final assembly place the unit against the wall where you want it to hang and trace lightly in pencil. Remember—as with all secret hiding places, the hole that you cut into the wall should be substantially smaller than the object that is to cover it.

On the back side of your rack you should have two steel rods that will fit into holes drilled into the 2x4 wall studs. To assure that these will line up, mark the locations of the beams on the rack, then drill the holes for the rods. After installing the rods in the back of the rack, press the rods against the studs and mark their location, then drill into the studs. When finished, these rods will not only serve to align the rack properly on the wall but will also give additional support should someone happen to lean against the rack.

Now, once the rack is totally assembled it will slide very easily on and off the wall, making the secret compartment accessible to you. For an added measure of security I would suggest that the movement be restricted. To that end you will note in the illustrations that on the rear of the rack there are four friction fasteners of the male kind and along the 2x4 beams there are four corresponding female friction fasteners. The number that was chosen was arbitrary. The actual num-

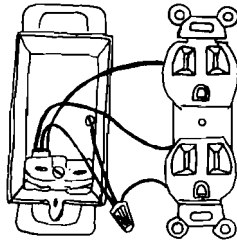

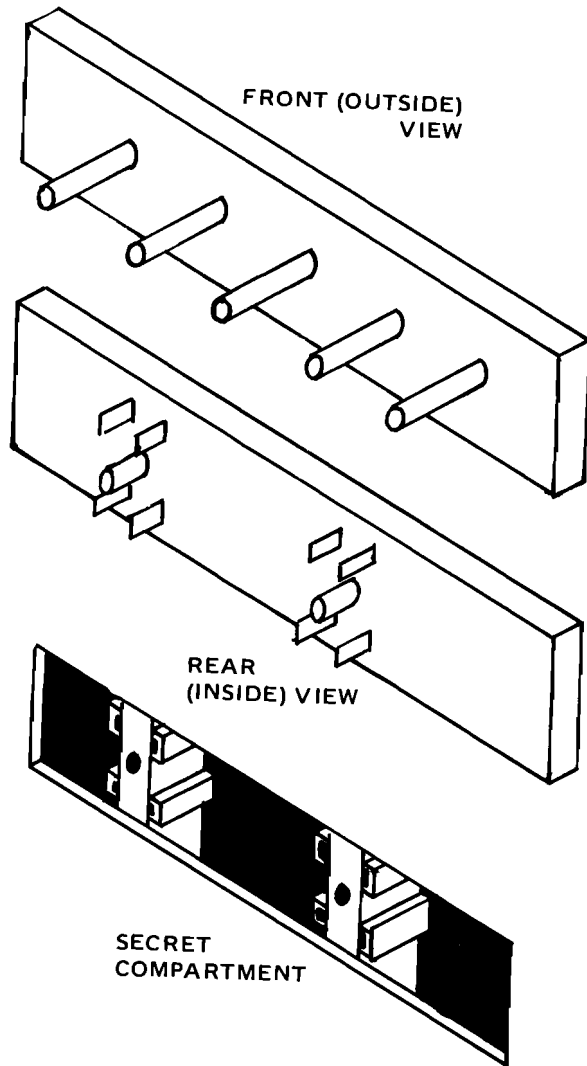

Figure 17.
Hat Or Gun Rack Stash Cover

ber will depend on how tight you want the rack to fit on the wall. My personal opinion is the tighter the better.

Obviously the hat pegs have to be secured very well as these will serve as the handles in gaining access to this stash. The proper tension should be one good healthy tug to loosen and one good healthy push to replace.

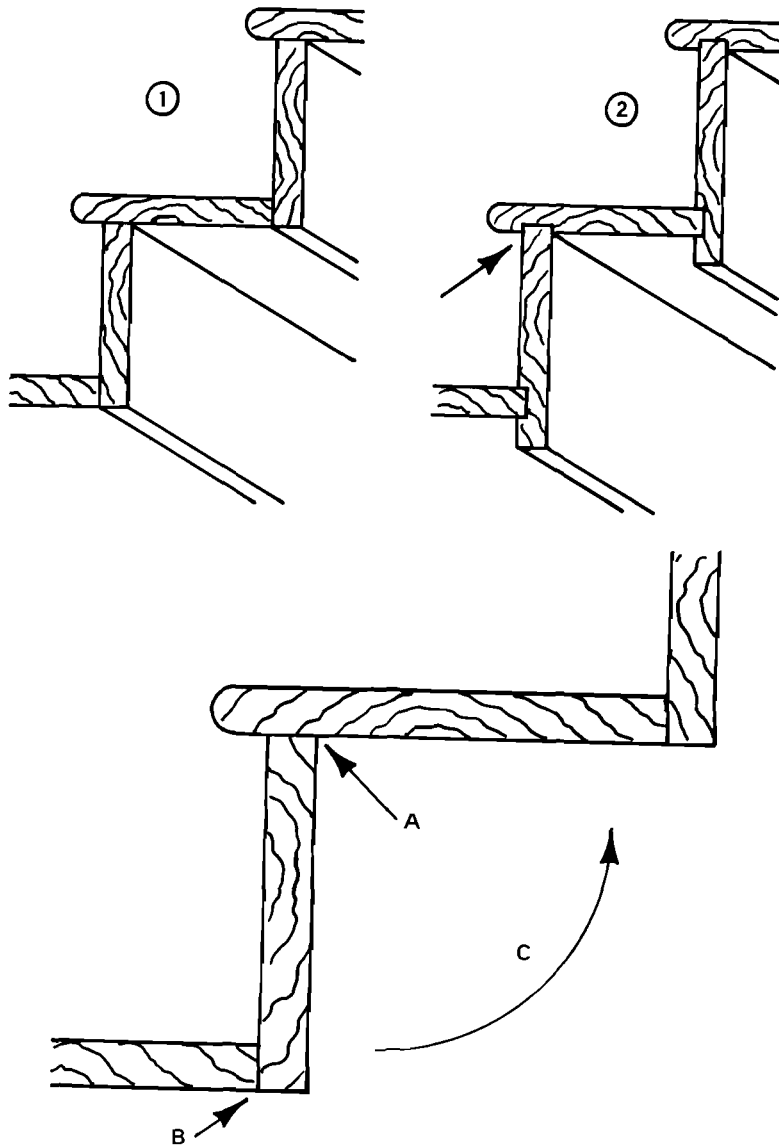

Figure 18.
Typical Stairway Construction

12. A Stairway To Secrecy

If you recall back to the beginning of the book when we were discussing dead space under stairs, you were told you'd be shown how to gain access. Well the time has come. Figure 18 shows the two kinds of stair construction. Types 1 and 2 are basically the same, the only difference being a minor one. In Type 2 you will notice that where the treads and risers join (treads are horizontal, risers are vertical), they are routed out. If your stairway is of the second variety, you'll have to re-work the groove at the area indicated by the arrow on Type 2.

To gain access to this space put several spring hinges at point A, some magnet fasteners at point B, and the riser will act as a swinging door, swinging along arc C.

In order to gain the proper access you will probably have to remove the sheetrock on the other side of the stairs. If you're partial to this type of secret compartment it will be worth the effort.

Most likely you'll find wedge arrangements used to tighten the stairs to eliminate squeaks. These can be overridden by the use of nails.

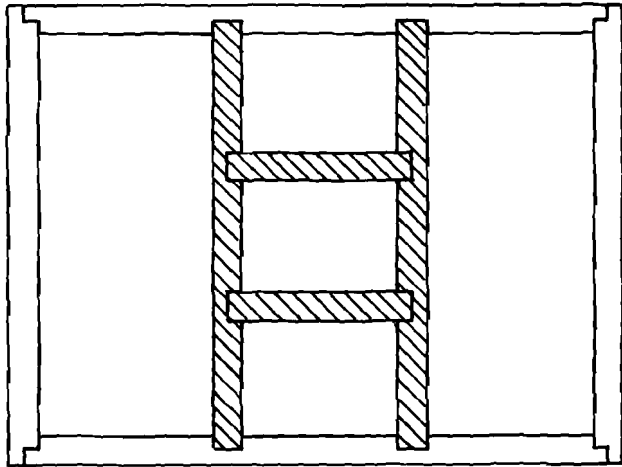

Figure 19.
Hiding Place Behind Removeable Shelves

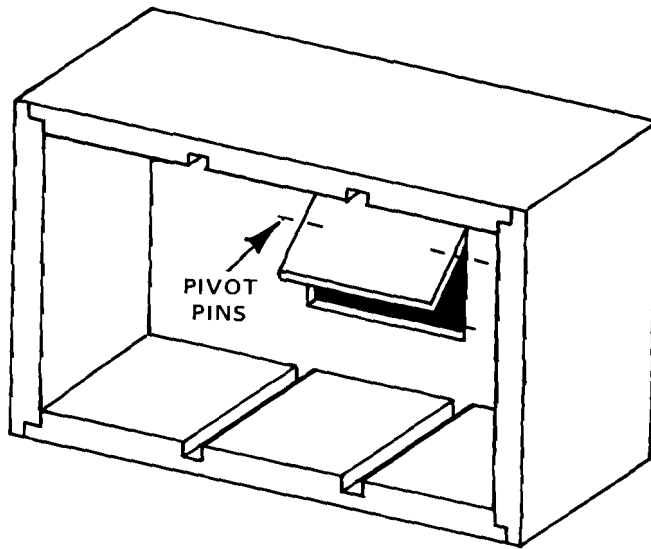

Figure 20.
Backboard, Outside Frame & Revolving Door

13. Secret Compartments Behind Shelves

One of the favorite and most widespread secret compartments utilizes shelves. The beauty of this type of stash is that it can be adapted to almost anyplace in the house and to almost any architectural setting. These shelves lend themselves well to living rooms, garages, basements and bedrooms. They can be either attached to the wall or countersunk. For this project you'll need a router and you'll have to pay a lot of attention to detail.

Essentially what we have is a backboard with a trap or revolving door built into it. This door opens into the space hollowed out between the studs. The lines of the door are covered by the edges of the shelves. The compartment can be opened by means of a spring hinge or a revolving door. Simply slide out the shaded boards as illustrated in Figure 19. Figure 20 illustrates the backboard, outside frame and revolving door.

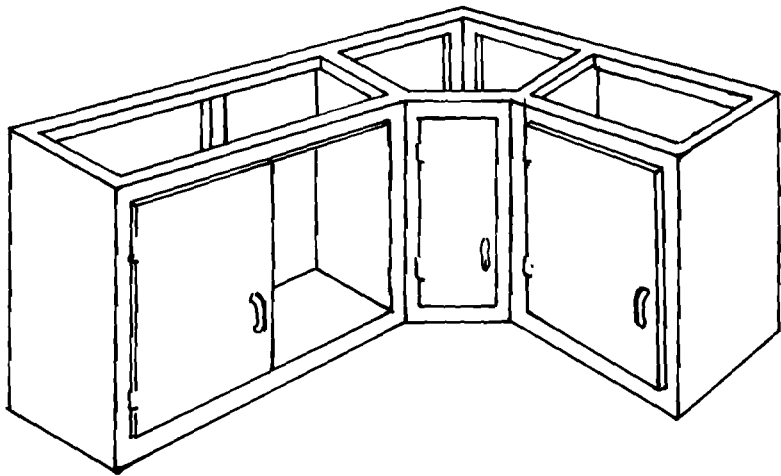
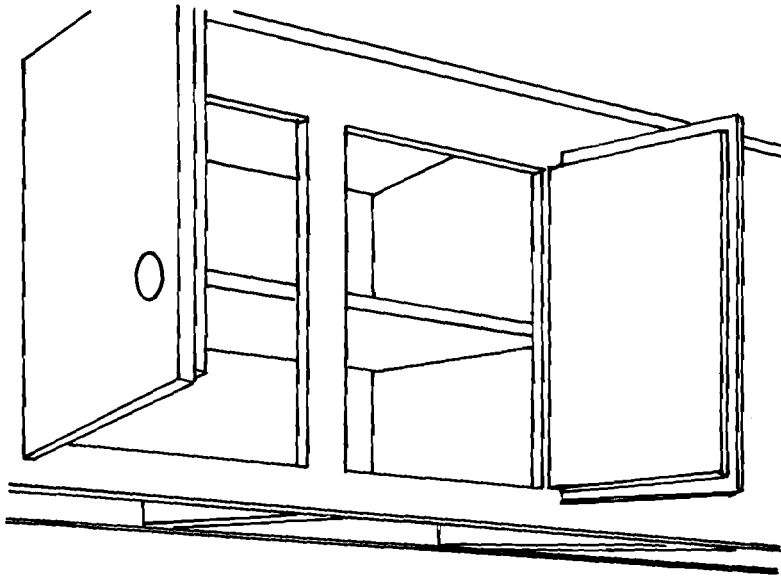

Figure 21.
Overhead Kitchen Cabinet Construction

14. Kitchen Cabinetry Stashes

One of the best ways to construct secret hiding places is to use existing cabinet work found in kitchens. If your top kitchen cabinets have built-in dead space on top you have a ready-made stash. Otherwise you can enclose the area yourself and have enough space for probably anything you'd want to hide. As shown in Figure 21, kitchen cabinets come in sections. What it will be necessary to do will be to remove one section. Normally they are just attached to the wall by screws. Check twice before pulling the cabinet down or you might have to re-sheetrock and repaint.

With one of the sections down, simply construct a removable top panel and when you reattach the cabinet to the wall you'll have access to the space above. In choosing which cabinet to remove the rule of thumb is to remove the smallest section that will allow the greatest amount of access.

Bottom kitchen cabinets offer less room but are more convenient to use and extremely easy to construct. What you first do is check out your bottom cabinets. You should find that you have a built-in floor in the cabinets and probably the only exception will be under the sink or possibly one section if you have drawers. The space extends to the wall and is approximately 5 or 6 inches deep. Volume-wise, it's a very respectable area.

One way to approach this space is by using the trapdoor principle as was used for the top set of cabinets but a much better way is to use the kickboard as an entrance. Take a

prybar and remove the kickboard. Figure 22 shows what you will find. Sometimes you will find an additional piece that must be removed, more often you will not. The bottom cabinets, like the top, are built in sections and each section will have vertical supports. Simply vacuum the area out (it will be plenty dirty too), and attach velcro to the supports with glue and tacks.

In the corresponding positions, likewise attach velcro on the inside of the kickboard. To cover the secret hiding place, simply push the kickboard into its space. To open the stash, just give a good yank. If for some reason you damaged the kickboard in removing it, get another board of the same dimensions from a lumber yard and also rubber molding and glue it to the kickboards of all the cabinets to camouflage your error. Check out your bathroom bottom cabinet also.

Well, one more stash and we'll get out of the kitchen and I'll show you how to construct secret rooms and panels. Don't skip ahead, though, because this next stash lends itself very well to a particular type of locking device that works well with secret panels as well as other stashes and right about now you should be ready.

On top of the bottom kitchen cabinets where the counter meets the wall you'll find the splashboard. By removing the splashboard you can hollow out the space between the studs and construct a suitable hiding place for many things. The preferred method of doing this is to use Soss invisible hinges as shown in Figure 23. Do this very carefully. All invisible hinges must be perfectly placed to achieve the desired purpose. Now in order to lock this stash simply install one or more cheap door latches on the inside. Only you will know their location. To open, simply push a putty or kitchen knife through and this will depress the latch like the old credit card door opening technique. Your stash will now open and when you close it, it will feel solid, just like the original.

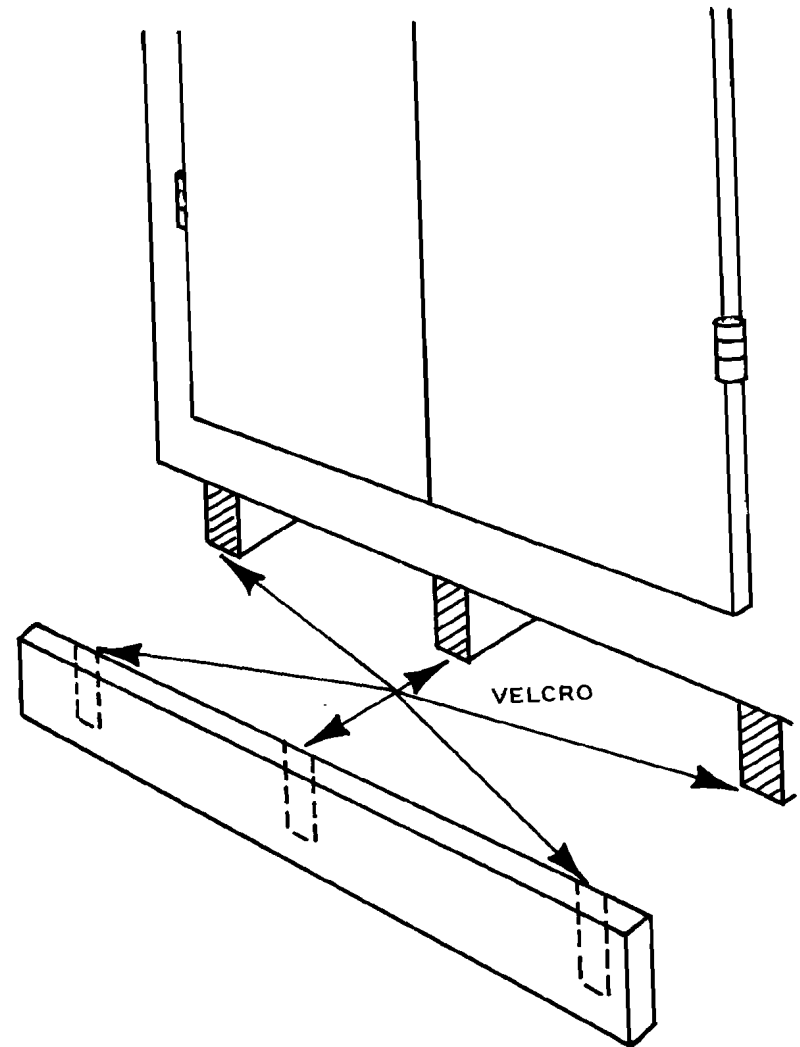

Figure 22.
Removeable Kickboard

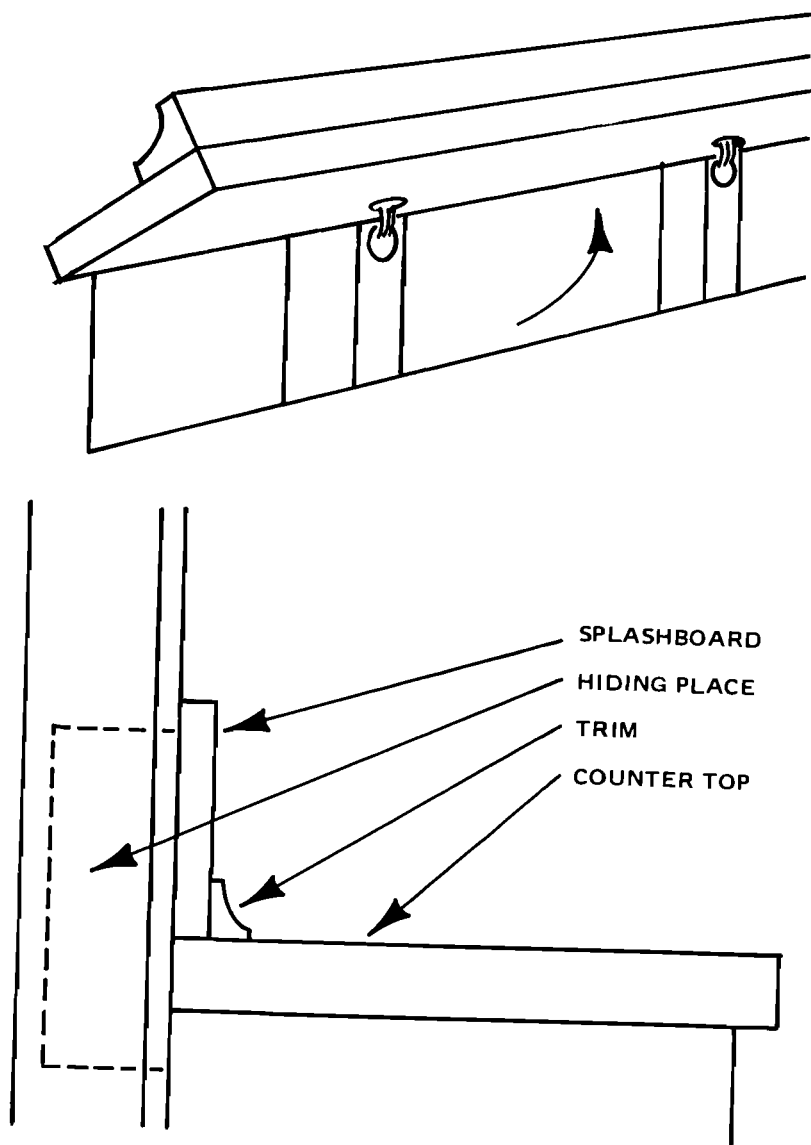

Figure 23.
Removeable Splashboard

15. Secret Rooms & Panels

Secret rooms are always a hit. You will find that it is relatively easy to make rooms, closets, etc., disappear, but like always, it is necessary to use good judgment. For example, if you live in an apartment, making rooms disappear will cause no suspicion. You can take a five room apartment and make it into a studio and no one will be wiser as it will be impossible to determine where your living space ends and another apartment begins. In a house, however, the situation is different and you'll most often have to settle for a smaller size such as a well chosen closet or suitable dead space.

Figure 24 shows the basic way to convert a room into a secret room. The first step is to remove the door and the molding. Now the only thing left for you to do is to fill the space with something suitable; in this case we've used a set of shelves. There are two very simple ways to gain access to the secret room. One, you can build a swinging door that swings into the secret room that will in effect become a crawl space, or two, you can have the whole set of shelving slide or pivot.

Remember—when building secret hiding places always try to have your access entrance swing into the secret space. This will make construction easier and eliminate the need for invisible hinges but also will remove the possibility of telltale scrapings on carpets and floors. Remember, you can't believe everything you see in the movies.

The third illustration in Figure 24 shows a series of shelves that have been built to cover the entranceway into

SECRET HIDING PLACES

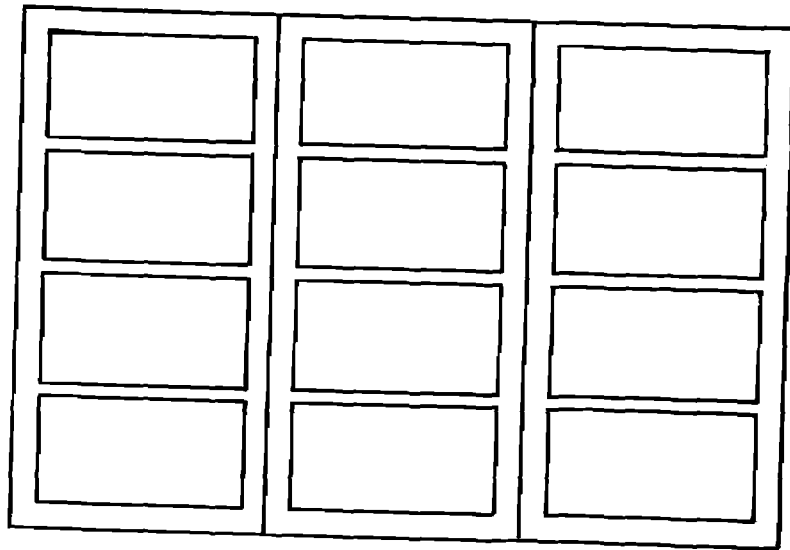
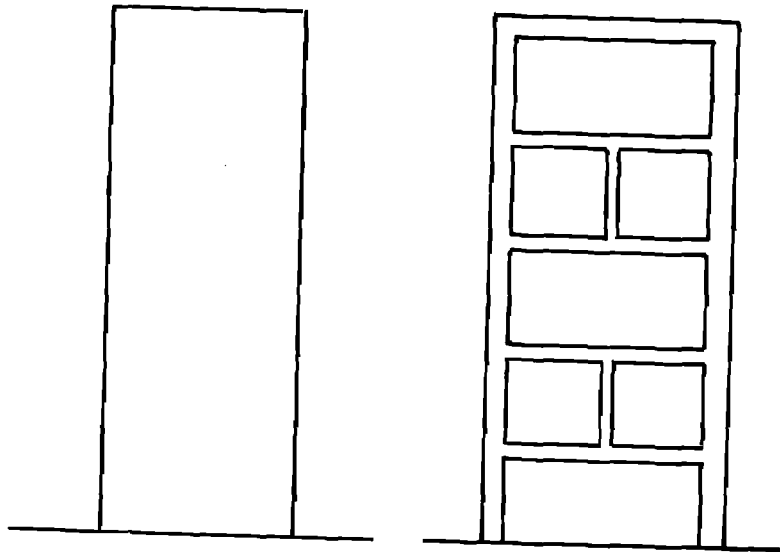

Figure 24.
Shelves Concealing Door To Secret Room

SECRET HIDING PLACES

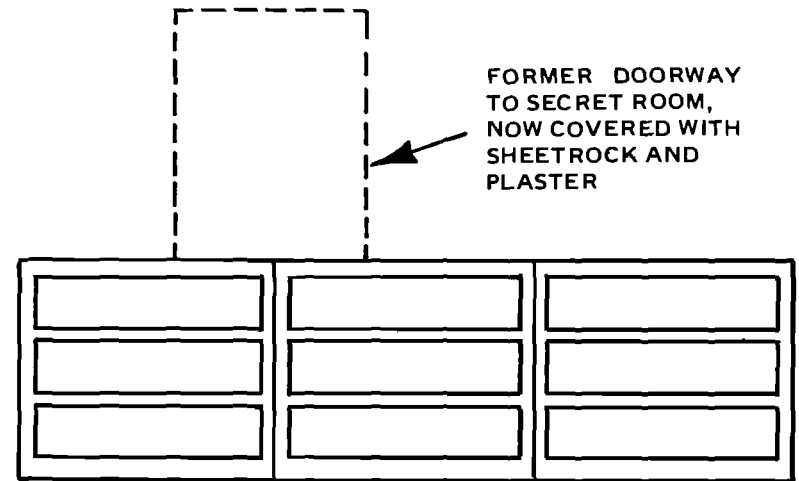

Figure 25.
Shelves Concealing Crawl Space To Secret Room

your secret room. This essentially is a technique used to camouflage the shape of the doorway you have removed.

The best way to construct an entranceway into a secret room in my estimation is illustrated in Figure 25. Simply remove the door and the molding into the room or closet that you want to use. Now fill in with sheetrock and build a set of low shelves across that wall. In back of one of the set of shelves simply construct a door to use and build the shelves so that the hinges and lines are concealed. By using the crawl space you gain access to the secret room. Paint the walls to hide the work you've done and paint or stain the shelves and you're all set.

Secret panels also seem to be very popular, probably due to the effect of Hollywood. Secret panels I find are very useful as an intermediary between a secret room and space hollowed out between the beams. Panels tend to give easy access to areas of large dead space.

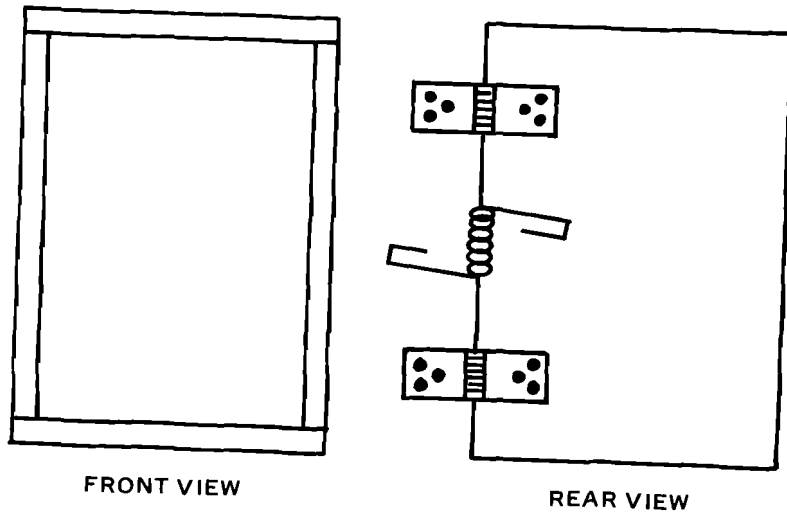
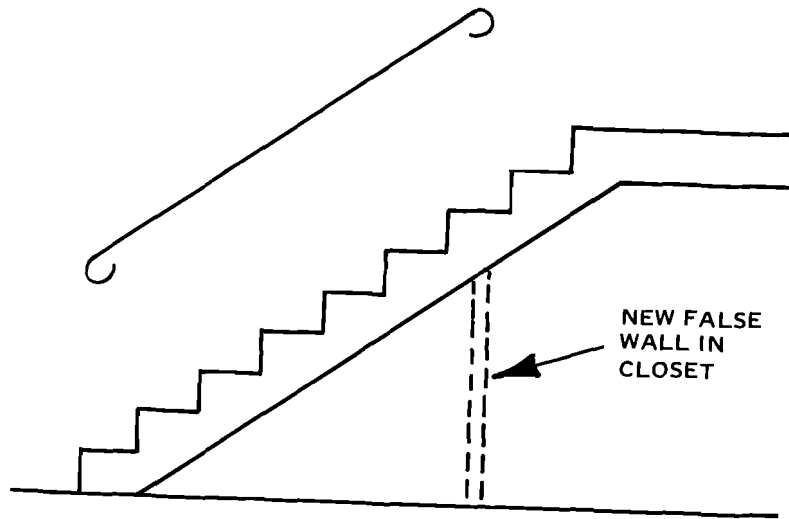

Figure 26.
Secret Panel In Closet Under Stairway

A very good place for a secret panel is shown in Figure 26, in a closet under the stairs. Very often if you don't have a closet under the stairs you can easily build one with a minimum of bother. Also, any good utility closet can do just as well. Let's face it, no one will know if you shorten a large closet by a foot or two anyway.

Essentially what we have in the illustration is a new back that has been added to the rear of the closet. Plywood or fiberboard is usually the best to use. Lathing strips are used to border the rear section which is in effect an entrance door that pushes inward. The lathing serves to hide the lines of the door.

Although only one panel is shown you can design the panel to include more than one piece. The choice is yours. This type of panel lends itself very well to the locking device described for the splashboard but also what you can do is to attach hooks, eyescrews, etc., to the new "back to the closet" to hang things on. Several of these hooks can penetrate through the lathing and into the door, thus locking it.

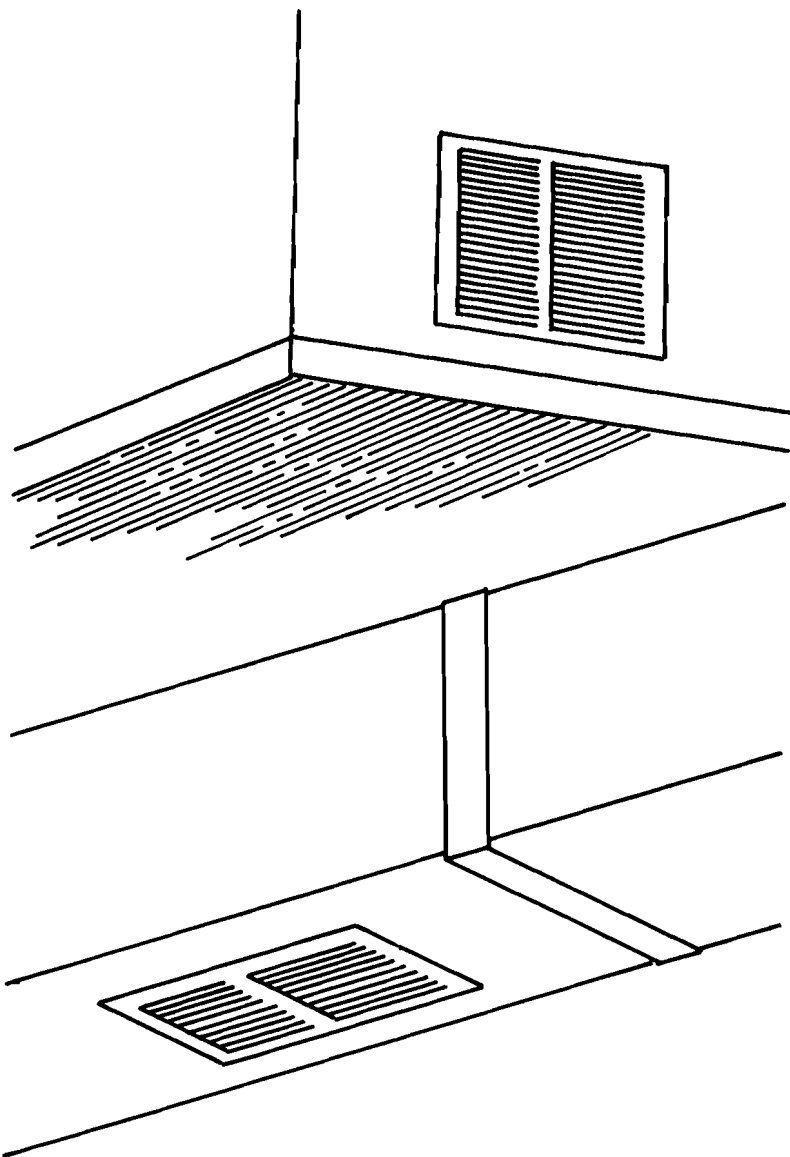

Figure 27.
Typical Wall And Ceiling Duct Vents

16. Heating & Cooling Vents

A very easy stash to construct and one that provides for quite a lot of space is to use the venting system of central air conditioning or forced air heat. Figure 27 shows a typical vent on the wall and also a typical vent in the basement. If you don't have a vent in the basement run, simply cut out a space and install a vent.

A word of caution in dealing with your venting system: Make sure that you place things in a horizontal run and not a vertical. Objects placed in the vertical runs will drop out of reach and you may have to remove large portions of the system to recover them. Always use the horizontal run and if the item is light, place it in a box and use a good-sized magnet to hold the item in place.

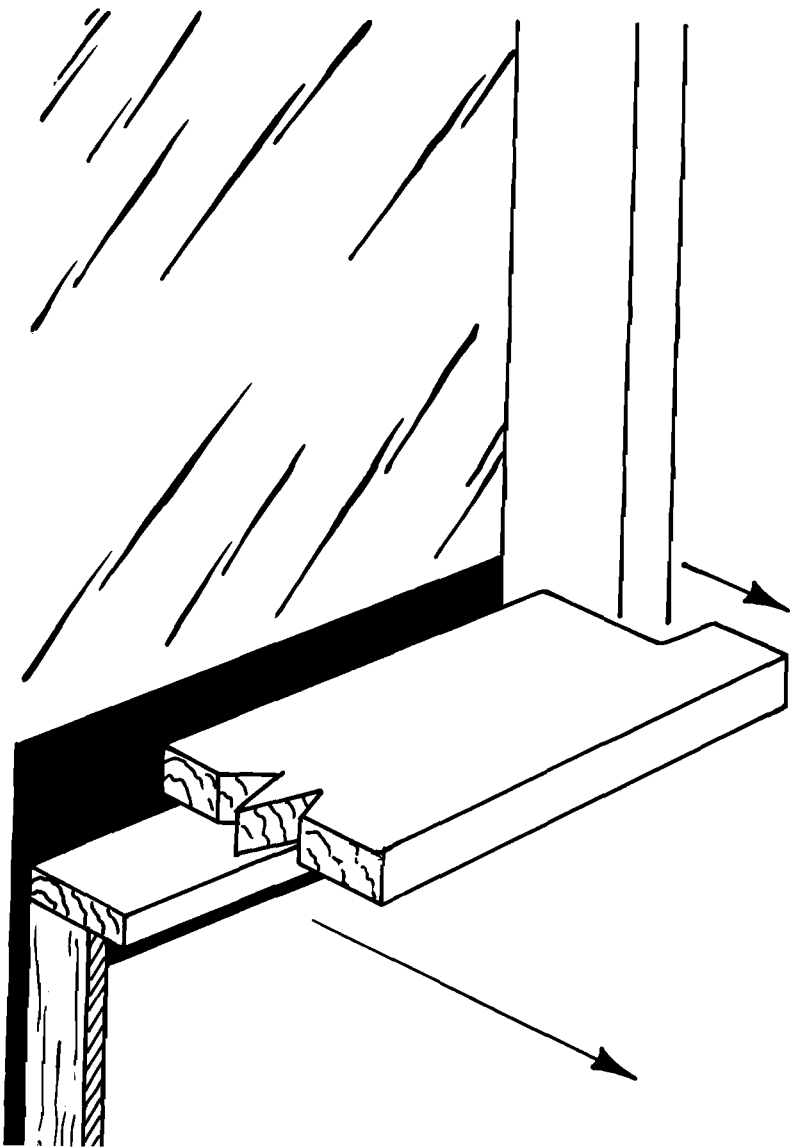

Figure 28.
Removeable Windowsill

17. Windowsills & Brickwork

An ambitious project is the building of a secret stash in a windowsill. Figure 28 shows its basic construction. This is a very exacting and difficult stash to make and should be reserved as one of your last resort situations. The reason is that if you're not proficient in your carpentry skills you may very well wind up creating a monster for yourself.

If you do contemplate using one of your windows to build a secret hiding place first visit a lumber yard and make sure that you can obtain the right sill board prior to beginning as you'll probably ruin the one you've got. Also, this will give you the opportunity to check out a variety of windows outside of a wall and serve to better familiarize yourself with what you will be dealing with.

Once you remove the sill you'll find 2x4's used to frame in the window. This frame must be removed and/or altered and the insulation removed.

This particular one is a really tough, ambitious project, but the reason it's mentioned is that if you're building a house or an addition, it's easier starting from scratch.

Brickwork abounds everywhere. Walls, houses, fireplaces. Often you will find a brick that has become loose and perhaps you'll want to utilize some space there.

Simply remove the brick and with a brick chisel cut the brick lengthwise to reduce its depth. Also, most brickwork that you find will be backed up by cinder block or other bricks and therefore allow you to further excavate this hiding space.

SECRET HIDING PLACES

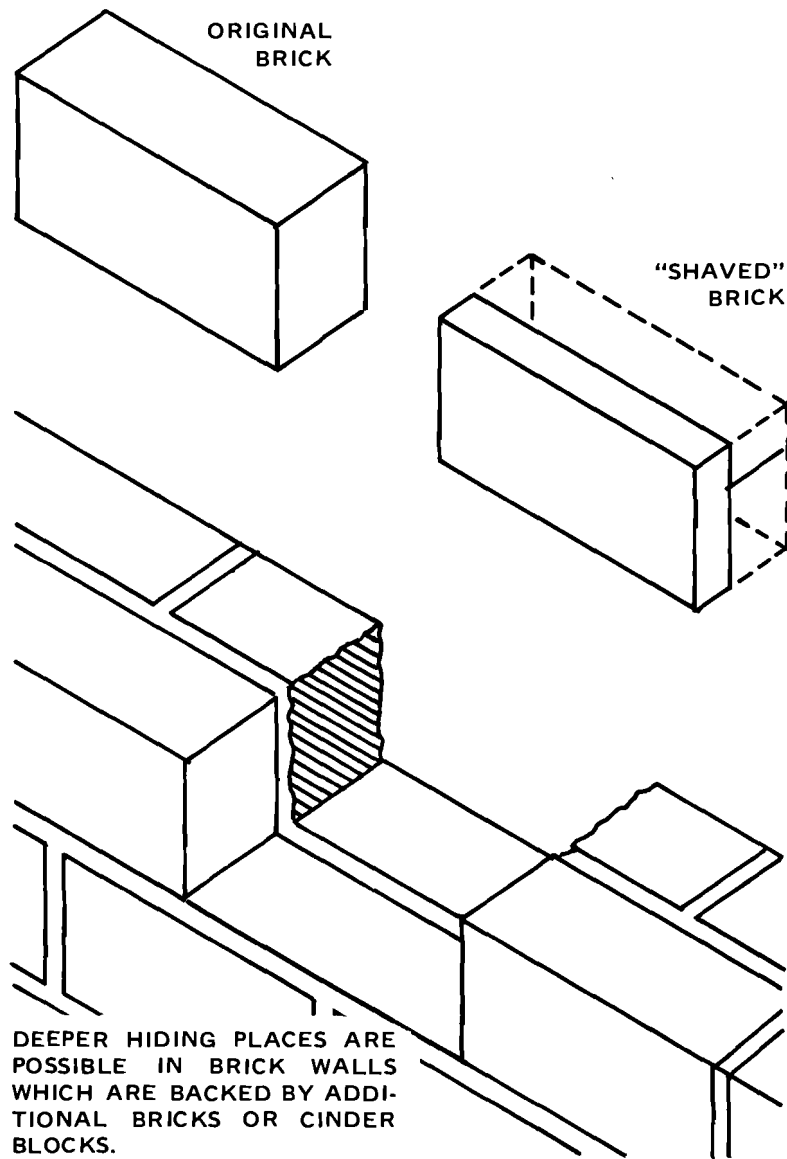

Figure 29.
Brick Hiding Places

Questions & Answers

Q. What's the main thing to keep in mind when constructing a secret hiding place?

A. Paying attention to detail. Most of the time when a person is involved in a project like this they fail to sit down and rationally plan what they're going to do and then methodically go about doing it. By being hasty they create more work for themselves than is actually necessary. Basically one has to plan the work and work the plan. Get all the materials that will be necessary prior to starting work.

Q. How do you handle security?

A. Just like the military, on a need to know basis. If you've done your job properly, and there's no reason why you shouldn't, the only way someone is going to discover your secret stash will be by some incredible accident such as an electrician making a call when you're not there and your wife not knowing you have a fuse box stash. Sometimes it's very hard to keep a secret from the whole world, but remember, "loose lips sink ships." I don't know of any case where a secret hiding place was discovered. If you build yours properly using the principles in this book you'll never have a problem—unless you create it yourself by telling the wrong person.

Q. What's the best way to handle cars?

A. Cars are tough. Dead space in cars are door panels, inside seats, inside dashboards, tires, etc. Without a good knowledge

of welding and bodywork you're going to have a difficult time, under most circumstances. If in fact it's necessary that you have some place in your car to hide something, like rolls of cash, etc., I'd suggest you go down to a car lot and check out a VW bug. Look at the difference in the floors between the front passenger's and driver's sides. If there's a different slant where the pedals go into the firewall on the driver's side, and there should be with the exception of one or two model years, you're in business. If you pull back the carpet on the passenger side, you'll find a plate where the floor changes from horizontal to an angle. Just give it a tug and you've got your stash. Why VW put it there is beyond me. Probably passenger comfort or something. If you have knowledge of metal work and carpet installation, you can do this same trick to any car, within reason.

While you're checking out VW's, I'll let you in on a little smuggling secret. All bug models, bus models, station wagons, etc., have a bottom-out plate welded onto the bottom of the chassis. If you're good with a torch and overhead welding and don't need to be in and out more than once, it's an ideal place to make your stash.

Q. What about floor stashes? I noticed that wasn't covered.

A. Well, let me say this about floors. Floors are more trouble than they're worth. Let me tell you why. Most floors you will run across are tongue and groove which means when you pry up the boards you'll break them. If you do things hastily, you just might find that you can't get that particular type of board so readily and you might have to take a piece from a closet floor, etc. Then you have the subflooring to deal with and you have to build a box between the supporting beams because if you're going to hide something that has some

weight the ceiling underneath will fall down if you haven't knocked it down already with your banging.

Q. There's a lot of different types of secret hiding places. What's the best way to choose among them?

A. Well, unless there's some immediate emergency don't be too hasty. First determine the size of the hiding space you will need and then take a tour of your home. Before doing anything, have at least three or four choices, pick the best for your needs of size, ease of access and whatever other personal demands you have. You may even want different stashes for different items. But look first, list your choices and pick what suits you best.

NOTES

NOTES

NOTES

NOTES

NOTES

NOTES

Other Books Available From Desert Publications

001	Firearm Silencers Volume 1	\$11.95	170	Military Knife Fighting	\$14.95
002	The Silencer Cookbook	\$8.95	180	Build Your Own AR-15	\$17.95
004	Select Fire Lid Modification Manual	\$11.95	181	Credit Improvement & Protection Handbook	\$19.95
005	Expeditious Hand Grenades	\$11.95	182	How to Build Flash/Stun Grenades	\$17.95
006	Springfield 19 Rifle Manual	\$13.95	183	Black Book of Arson	\$24.95
012	Fighting Gerand Manual	\$13.95	194	Entrapment	\$19.95
013	M1 Carbine Owners Manual	\$11.95	185	How to Live Safely in a Dangerous World	\$19.95
014	Ruger Carbine Cookbook	\$11.95	186	The FN-FAL Rifle Et Al.	\$19.95
015	M-1 Rifle, The	\$12.95	187	The Marxist Edge Reviewed	\$17.95
016	AR-15, M16 and M16A1 5.56mm Rifles	\$13.95	189	Survival Bible by Duncan Long	\$59.95
017	Shotguns, eight Gov. Types	\$17.95	190	The Criminal Defendants Bible	\$49.95
018	AR15 A2/M16A2 Assault Rifle	\$8.95	191	The Internet Predator	\$17.95
027	Full Auto Vol 4 Thompson SMG	\$11.95	192	Dental Specialist	\$59.95
031	Thompson Submachine Gun	\$19.95	193	Protect Your Assets	\$24.95
033	M&R Peeling Submachine Gun Manual	\$16.95	194	Medical Specialist	\$59.95
035	How to Build Silencers	\$6.95	196	How To Build Military Grade Suppressors	\$17.95
036	Full Auto Vol 2 Uz Mod Manual	\$11.95	195	The Poisoner's Handbook	\$24.95
046	Firearm Silencers Vol 3	\$16.95	197	Sten MKII SMG Construction Manual	\$19.95
050	Firearm Silencers Vol 2	\$24.95	199	Mossberg Shotguns	\$24.95
054	Company Officers HB of Ger. Army	\$18.95	200	Fighting Back on the Job	\$14.95
056	German Infantry Weapons Vol 1	\$8.95	204	Improved Munitions Black Book Vol 1	\$17.95
058	Survival Armory	\$27.95	205	Improved Munitions Black Book Vol 2	\$17.95
059	Survival Chemist Book	\$13.95	206	CIA Field Expedient Preparation of Black Powder	\$11.95
060	Survival Gunsmithing	\$11.95	207	CIA Field Expedient Method for Explosives Preparation	\$14.95
061	FullAuto Vol 1 Ar-15 Modification Manual	\$11.95	208	CIA Improved Sabotage Devices	\$17.95
064	M1 Assault Rifle Systems	\$27.95	210	CIA Field Expedient Incendiary Manual	\$17.95
065	S&KS Type of Carbines, The	\$17.95	211	Science of Revolutionary Warfare	\$16.95
066	Private Weapons, The	\$14.95	212	Agents HB of Black Bag Ops	\$11.95
067	Rough Riders, The	\$24.95	217	Improved Rocket Motors	\$11.95
068	Lasers & Vision Devices	\$24.95	218	Improved Munitions/Ammonium Nitrate	\$14.95
069	Ruger P-45 Family of Handguns	\$16.95	219	Improved Batteries/Deformation Devices	\$14.95
071	Dirty Fighting	\$11.95	220	Improved Explosives, Use in Deformation Devices	\$14.95
072	Live to Spend It	\$29.95	221	Evaluation of Improved Shaped Charges	\$11.95
073	Military Ground Rappelling Techniques	\$16.95	225	Improv. Munitions Black Book Vol 3	\$29.95
074	Smith & Wesson Autos	\$18.95	226	Poor Man's James Bond Vol 2	\$34.95
080	German MG-34 Machinegun Manual	\$19.95	227	Explosives and Propellants	\$14.95
081	Crossbows/ From 35 Years With the Weapon	\$11.95	229	Select Fire 1022	\$11.95
082	Op. Man. 7.62mm M&A Sniper Weapon	\$11.95	230	Poor Man's James Bond Vol 1	\$29.95
083	USMC AR-15/16 AR Manual	\$16.95	231	Assault Handcuffs	\$24.95
084	Urban Combat	\$27.95	234	L.A.W. Rocket System	\$14.95
085	Caching Techniques of U.S. Army Special Forces	\$12.95	236	Poor Man's Primer Manual, The	\$24.95
086	US Marine Corps Essential Subjects	\$16.95	238	How to Lose Your X-Wife Forever	\$24.95
087	The M1A1, The M1 Carbine	\$17.95	240	Standard One Man's Central America	\$11.95
089	Concocted Carry Made Easy	\$14.95	241	Mercenary Operations Manual	\$11.95
089	Apocalypse Tomorrow	\$17.95	250	Improved Shaped Charges	\$14.95
090	M14 and M14A1 Rifles and Rifle Marksmanship	\$21.95	251	Two Component High Explosives Mixtures	\$14.95
092	AR-15 Machinegun Manual	\$16.95	252	Survival Evasion & Escape	\$19.95
093	Map Reading and Land Navigation	\$19.95	262	Infantry Scouting, Patrol, & Sniping	\$16.95
094	U. S. Marine Corps Scout/ Sniper Training Manual	\$27.95	263	Engineer Explosives of WWII	\$14.95
095	Clear Your Record & Own a Gun	\$19.95	300	Brown's Alcohol Motor Fuel Cookbook	\$24.95
096	Sign Handing Manual	\$18.95	301	How to Build a Jerrylee CBB	\$15.95
096	Poor Man's Sniper Rifle	\$18.95	303	Alcohol Distillers Handbook	\$24.95
100	Submachine Gun Designers Handbook	\$19.95	310	M&A-10 Cookbook	\$11.95
101	Lock Picking Simplified	\$8.95	367	Brown's Lamsalt Cookbook	\$22.95
104	How to Fit Keys by Impressioning	\$8.95	400	Hand to Hand Combat	\$11.95
104	Keys To Understanding Tubular Locks	\$11.95	401	USMC Hand to Hand Combat	\$9.95
106	Lockout - Techniques of Forced Entry	\$13.95	402	US Marine Bayonet Training	\$9.95
107	Bugs Electronic Surveillance	\$14.95	404	Camouflage	\$12.95
110	Improved Weapons of American Underground	\$11.95	408	Guide to Germ Warfare	\$14.95
111	Training Handbook of the American Underground	\$16.95	410	Emergency Wargames	\$29.95
114	FullAuto Vol 8 M14A1 & Mini 14	\$11.95	411	Homeopathic First Aid	\$11.95
117	Improved Lock Picking	\$13.95	412	Defensive Shotgun	\$14.95
120	How to Open Handcuffs Without Keys	\$11.95	414	Hand to Hand Combat by D'Eliscue	\$7.95
122	With British Snipers, To Be Faithful	\$29.95	421	USMC Handcuffing	\$18.95
125	Browning Hi-Power Pistols	\$11.95	424	Prison Bloody Iron	\$13.95
126	P-08 Parabellum Luger Auto Pistol	\$14.95	425	Napoleon's Medicine of War	\$9.95
127	Walker P-38 Pistol Manual	\$13.95	432	Cold Weather Survival	\$11.95
128	Colt 45 Auto Pistol Manual	\$11.95	435	Homestead Carpentry	\$16.95
129	Beretta - M&M M0	\$13.95	436	Construction Secret Hiding Places	\$13.95
130	FullAuto Vol 5 M1 Carbine to M2	\$11.95	438	Survival Shooting for Women	\$14.95
132	Ranger Handbook	\$16.95	440	Survival Medicine	\$13.95
133	FN-FAL Auto Rifles	\$18.95	442	Can You Survive	\$16.95
135	M1-C7 Rifle	\$15.95	443	Canteen Gun Cookery	\$9.95
136	UZI Submachine Gun	\$11.95	444	Leadership Handbook of Small Unit Ops	\$14.95
136	USMC Battle Skills Training Manual	\$49.95	446	Vigilante Handbook	\$17.95
140	Sten Submachine Gun, The	\$6.95	447	Shooting & Hunting	\$14.95
142	U. S. Army Counterterrorism Training Manual	\$19.95	448	Catalog of Military Supplies	\$18.95
143	Sniper Training	\$24.95	454	Survival Childbirth	\$13.95
144	The Butane Lighter Hand Grenade	\$12.95	456	Police Karate	\$13.95
146	The Official M&A Pistol Manual	\$14.95	456	Survival Guns	\$24.95
147	Official M&A Army Pistol Manual	\$17.95	457	Water Survival Training	\$8.95
148	Unarmed Against the Knife	\$14.95	470	Emergency Medical Care/Disaster	\$14.95
149	Black Book of Booby Traps	\$19.95	500	Guerrilla Warfare	\$14.95
151	Millie Battle Manual	\$22.95	504	Ranger Training & Operations	\$19.95
153	Goetz's Handguns	\$18.95	507	Special Forces Detachment Training Handbook	\$16.95
153	Hacker and Koch's Handguns	\$18.95	511	U.S. Army Bayonet Training	\$9.95
154	The Poor Man's R. P. G.	\$22.95	542	Professional Homemade Cherry Bomb	\$13.95
156	The Poor Man's Ray Gun	\$11.95	544	Combat Loads for Sniper Rifles	\$14.95
156	The Anarchist Handbook Vol. 2	\$14.95	552	Aunt Beebe's Wood Stove Cookbook	\$8.95
157	How to Make Disposable Silencers Vol. 2	\$14.95	C-002	How to Open a Swiss Bank Account	\$9.95
158	Modern Day Ninjitsu	\$17.95	C-011	Defending Your Retreat	\$9.95
159	The Squeaky Wheel	\$14.95	C-020	Methods of Long Term Storage	\$9.95
160	The Sicilian Bible	\$15.95	C-023	Federal Firearm Laws	\$9.95
162	The Anarchist Handbook Vol. 1	\$14.95	C-023M1	Car's Arsenal History	\$7.95
163	How to Make Disposable Silencers Vol. 1	\$18.95	C-038	How to Build a Beer Can Mortar	\$4.95
164	The Anarchist Handbook Vol. 3	\$14.95	C-056	Navy Seal Manual	\$29.95
165	How to Build Practical Firearm Silencers	\$16.95	C-040	Criminal Use of False ID	\$14.95
165	Black Book of Revenge	\$15.95	C-176	Beat the Bus	\$7.95
168	How to Train a Guard Dog	\$13.95	C-386	Self-Defense Requires No Apology	\$13.95
172	Bantrophy, Credit and You	\$18.95			
178	Surviving Global Slavery	\$16.95			

PRICES SUBJECT TO CHANGE WITHOUT NOTICE

Desert Publications

215 S. Washington Dept. BK-436

El Dorado, AR 71730 USA

Shipping & handling

1 item \$4.95 - 2 or more \$9.95

800-852-4445