



Sailing and Trailering Guide

Sailing Your Hobie Cat Page 2-4

Balancing
Steering
Sail Power
Turning
Launching
Righting
Docking / Landing

Rudder Tuning Page 4-5

Trailering Page 5

Loading
Towing
Launching / Retrieving
Maintenance

Safety Tips Page 6

SAILING YOUR HOBIE CAT

Safe and sane guideline for the beginner; and an easy review for the experienced.

Always wear a life jacket when boating.

BALANCING THE BOAT

When sailing, sit on the upwind side of the boat (wind on your back) just in front of the tiller, facing the sail. Balance your weight further outboard as the boat begins to tip or heel over with the wind in the sails. Tuck one foot under the hiking strap for balance. Use your hand that is forward to hold and control the mainsheet. Use your hand that is aft to steer.

STEERING

Steer the boat by pushing the tiller away from you to turn towards the wind. Pull the tiller towards you to turn away from the wind. Keep the movement of the tiller to a minimum to prevent over-steering. This will help you keep the boat moving in a straight line as you pay attention to other watercraft and sail adjustments.

SAIL POWER

Face the sail in order to pay close attention to the trim or adjustment of the sail. When the front of the sail, just behind the mast, luffs or flutters in the breeze, you lose power. To start moving, pull the sail in just enough to stop the sail from luffing. There are also short ribbons hanging on either side of the sail. Follow the diagram of sail and course adjustments above using the "tell tails" to get the most performance out of the sail for all angles of sailing. The tell tails react to air flowing over the sail and will help you see that the sail is pulled in too tight or too loosely. If you pull the sail too tight you will stall the sail power. Ease the sail out until it luffs, then pull it in just a little until it stops luffing. You will adjust the trim whenever the wind changes direction or you change course.

Refer to the sail trim diagram below for approximate sail settings for the different points of sail or directions you will be sailing. Note the "can't sail zone". You cannot sail in this direction due to the fact that the sail will luff constantly when pointed into the wind. If you get stuck in irons (or stop pointed into the wind) you will need to reverse the rudder and push the sail forward to back-wind it. The jib should be back winded by the crew to assist. This will back the boat up. Reverse the rudders and let the sail out until the boat is positioned more across the wind (close reach). Then you can correctly trim the sail and start moving forward.

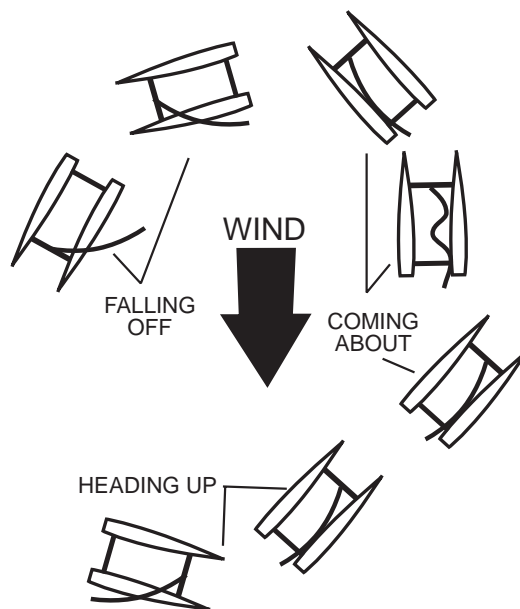
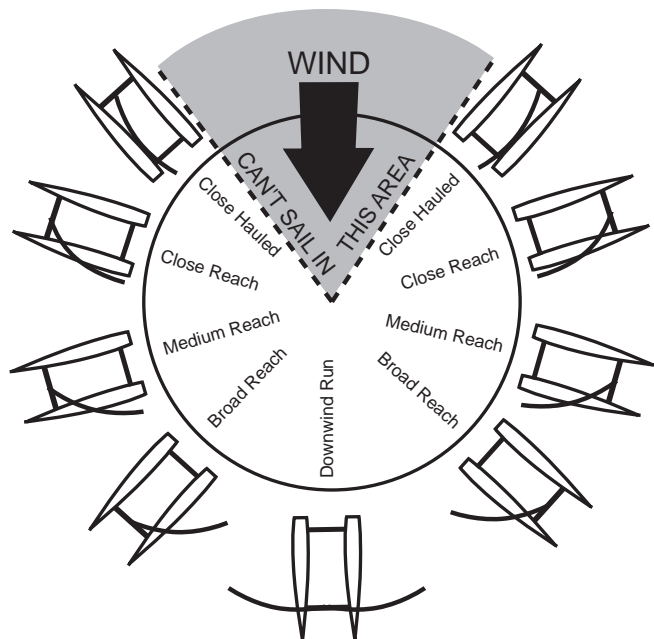
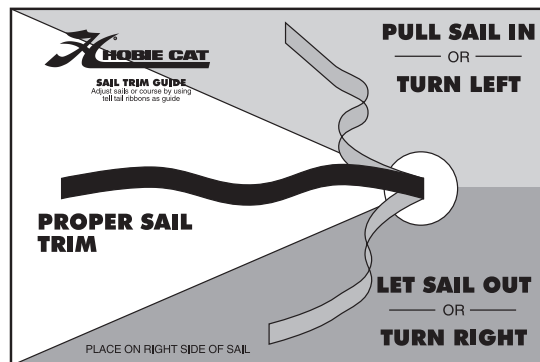
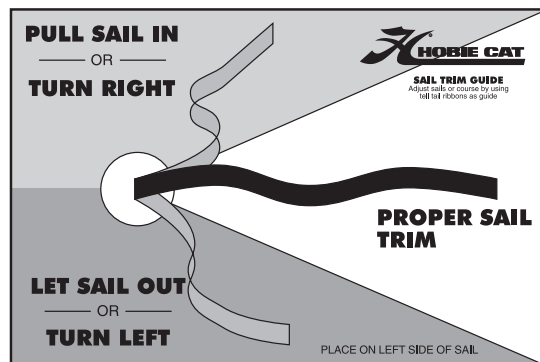

TURNING

To tack or turn the boat into and across the wind to the opposite direction (also known as "coming about"), follow the points of sail guide illustration and take the boat to the close hauled point of sail. This is when you are nearly 35 degrees from sailing straight into the wind. With the boat moving forward and not stalling, push the tiller away from you slowly. When the boat is pointing straight into the wind the boat will become level. Ease the mainsheet trim out just a little. At this time move your body to the other side of the boat, switch hands with tiller and mainsheet and begin to bring the rudder back to straight. The crew should move across the trampoline at the same time. The crew is responsible to ease the jib sheet just after the main sail is released and sheet the jib onto the new course before the mainsheet is trimmed. This action by the crew will prevent the boat stalling head to wind. As the boat comes across the wind and falls off onto the opposite, close hauled point of sail, bring the tiller all the way back to the straight position and pull the mainsail back in for the proper sail trim. If you stall pointing into the wind and you cannot steer the boat, refer back to the sail power description concerning getting stuck in irons.

When sailing downwind, the turn from one point of sail across to the other is called a jibe. The jibe is completed by turning away from the wind (falling off) to the opposite point of sail rather than into the wind as when tacking. Care must be taken when attempting a jibe as the boat will be at full power and you cannot easily de-power it without turning back into the wind. Also, be aware that the boat will be less stable in this maneuver as the sail will now have to swing clear across from fully out one side of the boat to fully out the other.

To start a jibe, turn the boat away from the wind and let the sail out slowly. Keep the turn going at a steady rate and begin pulling the sail back in as the boat nears the straight downwind direction. This will help prevent the sail from slamming all the way across when the sail fills from the opposite side. Duck below the sail to avoid getting hit as the wind fills the sail from the opposite side and swings across the boat. Attempt to control the speed of the sail while it crosses the deck by maintaining some tension on the mainsheet. Then ease the mainsheet out quickly as the boat turns past the downwind direction onto the new point of sail. Trim the sail correctly for the desired point of sail.

LAUNCHING THE BOAT

Launching the boat is easiest when the boat can be pointed into the wind to keep it de-powered and floated into deep enough water to lower the rudders. It is possible to launch in shallow water with the rudders partly up. Try not to steer with too much force on the rudders until you lock them in the down position. Keep the sail loose and trimmed out completely until you can power up and steer away from any obstacle. Trim the sail in quickly to get the boat moving forward and steer away from the wind slightly to prevent stalling into the wind.

When launching from a beach where the wind is blowing from the beach towards the water you simply keep the boat pointed

into the wind. Drift backwards with the rudders in the up position and your weight towards the front of the boat. Stay forward as the boat drifts into deeper water. You can hold the sail out to catch wind backwards to increase reverse speed. Then move to the rear and lower the rudders. It will be easiest to lower only one rudder while moving backwards. Then lower the other when the boat begins to move forward again. Be aware of the intended direction you wish to sail when lowering the rudder and steer the boat as the rudder drops into the water. There will be a lot of force on the rudder to turn one way or the other when going backwards. Plan ahead and steer the rudders so that they will be pointing in that direction before dropping it into the water. Steer the boat while going backwards so the bow turns away from the wind and toward the direction you wish to sail. As the sail begins to fill with wind, the boat will slow then begin to move forward. Trim in the sail and off you go.

RIGHTING THE BOAT

If you tip the boat over, stay with the boat. The boat will not sink and is easy to right. It is not necessary, but it is easier, to right the boat when the bow and the mast are pointed into the wind as in the following diagram.

There will be less wind resistance and better control in this position.

Be sure the mainsheet is released, then swim around to the bottom of the boat. Skipper and crew should climb up on the hull and stand up. Using the righting line (installed above) skipper and crew pull the righting line that is against the upper hull and hold the line while slowly leaning back away from the trampoline. Lean to approximately 45 degrees for best leverage. As the mast and sail lift out of the water and the upper hull begins to drop back into the water, drop down to your knees then into the water. Hold onto the righting line near the crossbar or the crossbar itself near the hull that you were standing on. This will prevent the hull from being lifted into the air by momentum which could cause the boat to capsize once again. Be well aware of the hull and crossbar coming down over your head. Holding the crossbar or righting line will also insure that you remain with the boat when it is righted. Climb aboard and continue sailing.

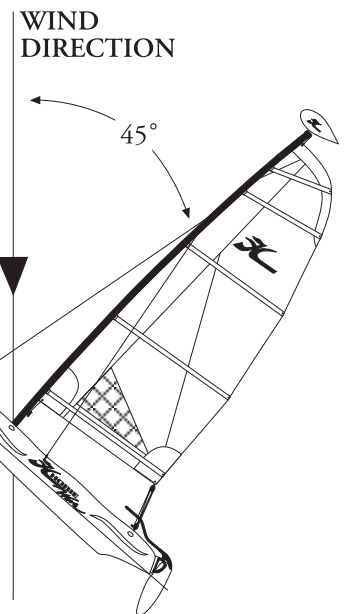

DOCKING

Docking the boat properly will prevent damage. Always dock and rig on the leeward side of a dock (the side the wind reaches last). Come in slowly and always be aware of the wind direction so you can properly de-power the boat when needed. The stronger the wind the more difficult the docking will be. Until you feel confident, you may want to practice with a friend who will remain on the dock and help slow you down if necessary.

BEACH LANDINGS

Landing on a beach is simple. The idea is to reach the beach in the point of sail nearest straight into the wind as possible. This will assure that you can properly de-power the sail once beached.

Approaching a beach when the wind is blowing from the beach out towards the water will require some planning so that you maintain power. Turn into shore just before the hulls or rudders touch bottom. Plan so the final tack towards the location you choose to land is the tack that is nearest straight into the wind. Get a little closer to the beach than you need on the previous tack to account for wind shifts in direction and speed. This will give you a little room for error. This will allow you to point a little further away from the wind after the tack to gain speed before heading up into the beach to de-power at the last moment.

When approaching a beach when the wind is blowing onshore, sail in towards the beach from either side of the landing spot. Sail in just short of touching the bottom with the rudders. Allow some distance to turn the boat out towards the water and into the wind just out from the landing spot. Turn sharply to head into the wind and stall the boat. Raise the rudders and drift back onto the beach.

Always keep the boat pointed into the wind while beached and keep the sail trimmed out and un-cleated.

RUDDER TUNING

You may adjust the rake of your rudder blades on your Hobie boat. The amount of rake in a rudder blade affects the "feel" at the tiller. Basically, more forward blade rake neutralizes the pull on the tiller and less forward rake increases the pull on the tiller. Tuning blades for a comfortable feel is a matter of individual preference but a close to neutral "feel" generally provides the best steering. The following sketches are of a Hobie 16 rudder assembly but the adjustments are the same.

1) The first step in making any rudder rake adjustment is to determine the existing rake. This is done with the rudder assembly hanging on the boat's transom, blade down and locked. Using a straight edge or snap line, extend the centerline of the rudder pivot pins down, across the leading

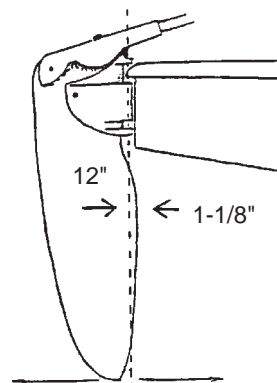

Aft for more pull on the tiller

Forward for less pull on the tiller

edge of the blade and draw a pencil line along that length. Measure the distance from the pencil line to the most forward spot 12" down the blade from the bottom of the casting..

Rudder blade rake is pre-set at the factory to 1-1/8". This amount will be best for the average sailor and is a good starting point from which to begin any adjustments.

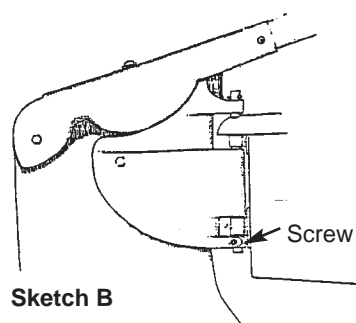

Sketch B

2) To make any adjustment to the rake, unlock the tiller arm from the rudder housing and leave it unlocked.

3) If you wish to increase the amount of forward rake in the rudder blade, turn the rake adjusting screw counterclockwise using a 3/16" Allen wrench. Determine the increase in the rake by extending a new line from the centerline of the pivot pins. Re-measure the distance from the pencil line to the leading edge. Continue to adjust and measure until you have the desired amount of forward rake.

4) If you wish to decrease the amount of forward rake turn the adjusting screw clockwise using a 3/16" Allen wrench. Check the decrease in the rake by the procedure in step 3 above .

5) Next, while holding the rudder forward against the lower casting, carefully latch the tiller arm down onto rudder housing. Loosen the adjusting screw on top of the tiller arm about 3/4 turn. Slide the adjusting screw forward (toward bow of boat) until it stops, then retighten. See sketch C.



Sketch C



6) Hobie Cat rudder blades are preset to break away from the locked down position at 17-26 pounds by testing with a line around the rudder blade seven inches above the lowest tip of the blade. Once the rake is changed, the breakaway tension should be rechecked. The tension may be adjusted by turning the 3/4" internal screw in the housing. The screw tensions an internal spring. Turn it clockwise to increase and counter clockwise to decrease the tension.

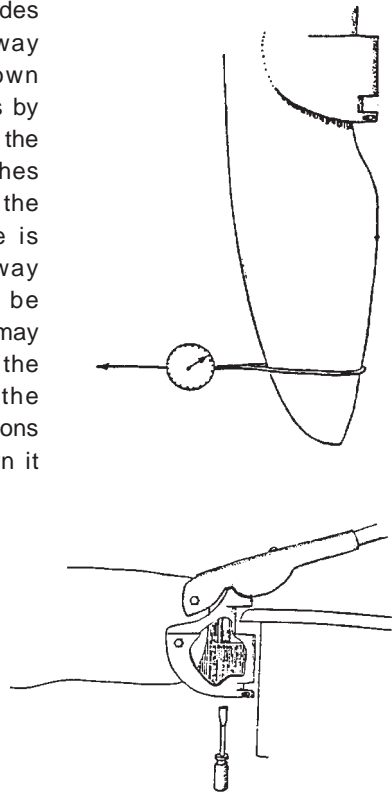

TRAILERING

CAUTION: Boat and mast should be securely attached to trailer with adequate tie-down straps. Failure to do so could cause extensive damage or serious injury!

LOADING YOUR TRAILER

The weight of the boat, equipment and additional gear should never exceed the manufacturer's rated weight capacity. Proper distribution of the load is of vital importance. Too much weight on the hitch will cause "tail dragging" of the towing vehicle, impairing steering and raising headlights into the eyes of oncoming traffic. Too little or negative weight on the hitch, and the trailer will sway or "fishtail". The solution to proper distribution is often adjusting movable gear. A more permanent solution is to shift the axle position before taking your boat to water the very first time.

TOWING

Extra caution is necessary when towing any trailer. The heavier the rig, the more time required to accelerate, pass, and stop. For this reason, the maximum speed for vehicles with trailers is less than without a trailer in most states. A long rig requires a larger turning radius. Curbs and obstructions should be given wide clearance. Most boats on trailers obstruct the rear view of the driver. When this happens, an additional rear view mirror on the right side of the towing vehicle is required by law.

The trailer boatman should be familiar with traffic and highway laws relating to the towing of trailers. Towing a Hobie has particular hazards that should be mentioned. A Hobie is very wide. Obstacles should be given plenty of room when you are passing them. Tie down straps or lashings should be of sufficient size and diameter and placed on all four corners.

The mast support on a trailer is subject to a lot of side-to-side motion and consequently may fatigue where it is welded to the trailer. All this can be reduced by tying a line from each bow to the mast support. This will stiffen the rig up and prolong the life of the trailer.

LAUNCHING AND RETRIEVING

Prepare boat for launching at the top of the ramp or parking facility. Remove all tie-down straps, check boat plugs and fasten boat painter. Do not release winch line until the boat is in the water. Back trailer to the left if possible; backing left gives better launching visibility. Avoid dunking wheel bearings wherever possible. Never leave the towing vehicle unattended on the ramp with only the parking brake set. If vehicle must be left while on the ramp, set transmission in "park" or first gear, in addition to setting the parking brake. In retrieving your boat, make sure that the boat is properly placed on the trailer. Pull trailer up steadily to prevent spinning the wheels.

TRAILER MAINTENANCE

Lights: Most state laws require two red taillights on the rear that may be combined with the stop and turn signals. Vehicles over 80 inches in width require clearance lights. If lights are dunked, waterproof light fixtures should be used. If water is allowed to enter, the lamp may crack and short out the entire system. Water also promotes contact corrosion. Always carry spare lamps. The wire coupling to the towing vehicle should be high enough to stay dry. Never rely on the trailer hitch for ground connection. Four-pole connectors should be used.

The mast should not extend over three feet behind the rear light assembly.

Wheels: Tires should ALWAYS be inflated to manufacturer's recommended pressure. Always carry a spare wheel and a jack that fit the boat trailer. If wheel bearings are always dunked, waterproof bearings and caps should be considered. If water is allowed into the hub, lubricating grease will float away and bearings will burn out or seize, causing damage and a safety hazard. Waterproofed bearings should be inspected prior to each boating season, others more often. Special care should be given when traveling on unimproved roadways with small diameter wheels.

If a spare wheel is not available, a spare wheel bearing set should be taken on long trips in case the grease seal has been broken.

FRAME AND ROLLERS

Rust should not be allowed to accumulate. Remove rust and repaint with anti-rust paint. Some trailers offer galvanized coating to prevent rust. Rollers should roll freely and should not have checks, breaks or flat spots.

TOWING VEHICLE

Most vehicles are limited in towing capacity. Towing heavy loads places extra demands on the engine, transmission, brakes and other systems vital to the vehicle. Towing "packages" are available through most auto dealers and should be considered for heavy boats.

CAUTION / SAFETY TIPS

- **Watch for overhead power lines.** Never rig, trailer or sail the boat near overhead power lines. Contact with a power line could be fatal.
- **Sail to your experience.** Do not try to do more than you can. Do not take the boat out in the surf and do not head out for the ocean unless you are a real professional.
- **Wear a life jacket.** Wearing life vests while sailing is important for everyone. Due to the large number of novice sailors that have purchased the boat, it is even more important to review this safety issue. Wearing a life vest is a smart thing to do. Also, a sailboat could sail away by itself if a person were to fall overboard. The best advice to a sailor is to stay with the boat. If they happen to fall overboard, or when righting the boat, they should hold onto the boat and not let it get away.
- **Learn the right-of-way rules** and when in doubt, *give way* to others.
- **Adhere to car roof rack manufacturer's weight limitations and tie down suggestions when car-topping the boat.** (The combined weight of the boat hulls and mast is approx. 150 lbs.)
- **When trailering the boat be sure to tie the boat and all the loose parts to the trailer in a secure manner.** Stop and check the tie downs often.
- **Hobie Cat does not recommend leaving the boat in the water on a mooring.** Accelerated wear to the boat and rigging will be experienced. Damage to the hull material is possible. Limitation of the mast rotation and tensioning of the rigging are required to lessen this wear. Inspect rigging often and tape rigging rings and shackles to prevent loosening.



HOBIE CAT

4925 Oceanside Blvd.

Oceanside, CA. 92056

Phone (760) 758-9100 Fax (760) 758-1841



...The FUN starts here!

For your nearest HOBIE dealer
or
for help and information call:

1 (800) HOBIE - 49 / www.hobiecat.com