

**AT** MICROFICHE  
REFERENCE  
LIBRARY  
A project of Volunteers in Asia

Workshop Equipment: How to Make Planes, Cramps and  
Vices: Seven Woodworking Tools

By: Aaron Moore

Published by: Intermediate Technology Publications  
9 King Street  
London WC2 8 HW  
U.K.

Available from: Intermediate Technology Publications  
103/105 Southampton Row  
London WC1B 4HH  
U.K.

Reproduced with permission.

Reproduction of this microfiche document in any form is subject to the same  
restrictions as those of the original document.

# WORKSHOP EQUIPMENT

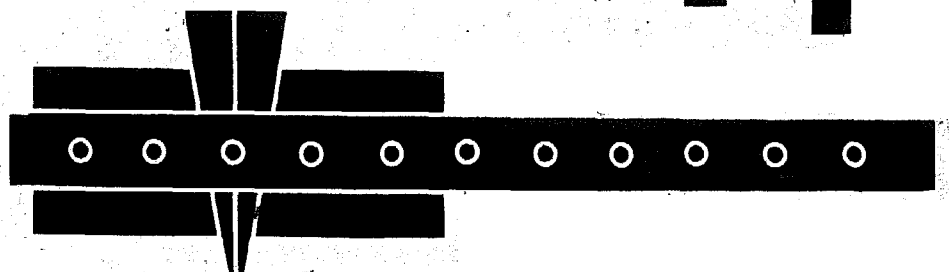
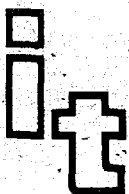
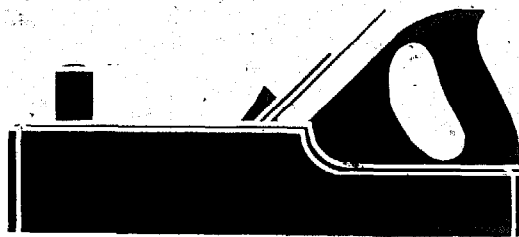
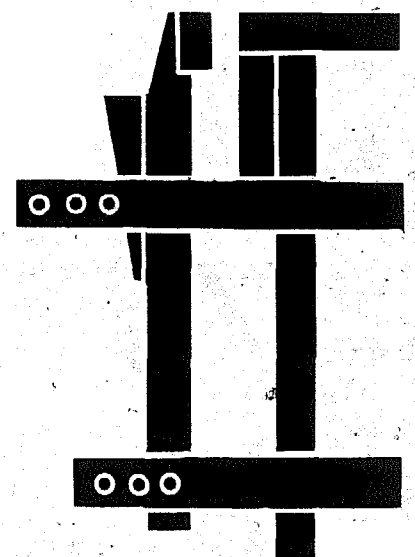
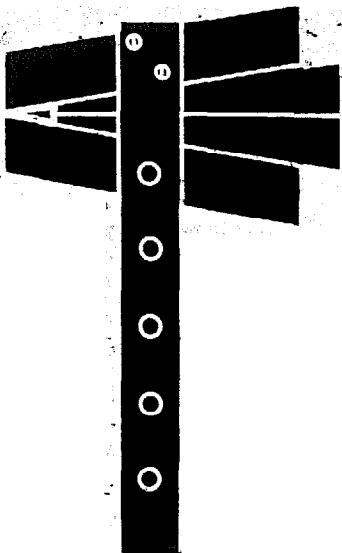
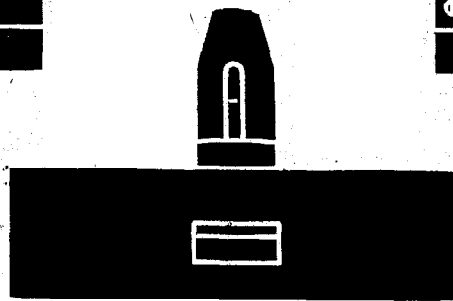
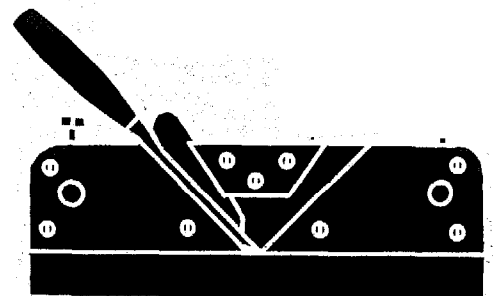
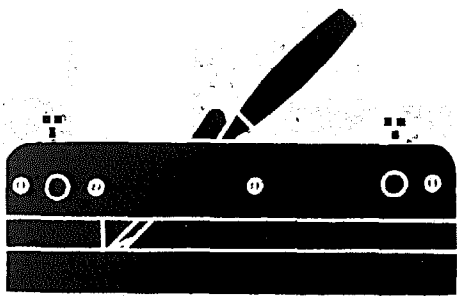

# **How to Make Planes, Cramps and Vices**

*Written and illustrated by Aaron Moore*

Step-by-step instructions on how to make: JACK PLANES, REBATE PLANES, PLOUGH PLANES, SPOKESHAVES, SASH CRAMPS, BENCH CRAMPS and VICES.

# **Acknowledgements**

Financial assistance in the production of this manual was made available through the Intermediate Technology Development Group, from a grant given by the Overseas Development Administration. Their assistance is gratefully acknowledged.

© Intermediate Technology Publications 1987  
9 King Street, London WC2E 8HW, U.K.

ISBN 0 946688 98 2

Printed by the Russell Press Ltd., Bertrand Russell House,  
Gamble Street, Nottingham NG7 4ET, U.K.

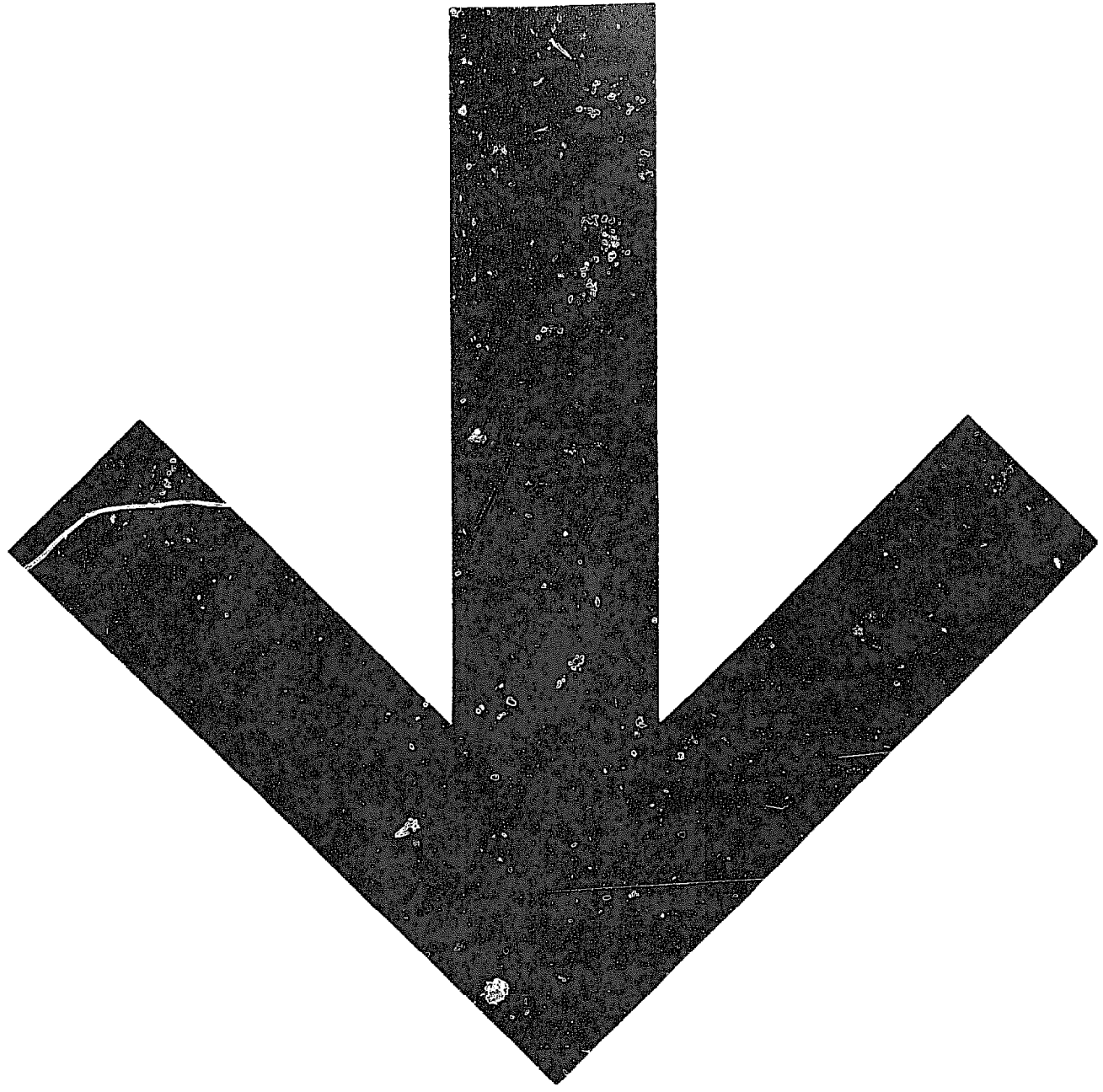

# Contents

	page
Introduction	1
The tools	2
Glossary	3
Jack plane	5
— handled version	21
Rebate plane	33
— adjustable fence	44
— alternative fence assembly	52
Plough plane	55
Spokeshave	69
Sash cramp	79
Bench cramp	87
Leg vice	99

## ERRATA

p.35 — Part D: The dimensions should read 250 × 65 × 20

p.57 — Part B: The dimensions should read 250 × 35 × 25

p.57 — Part E: The dimensions should read 250 × 50 × 25

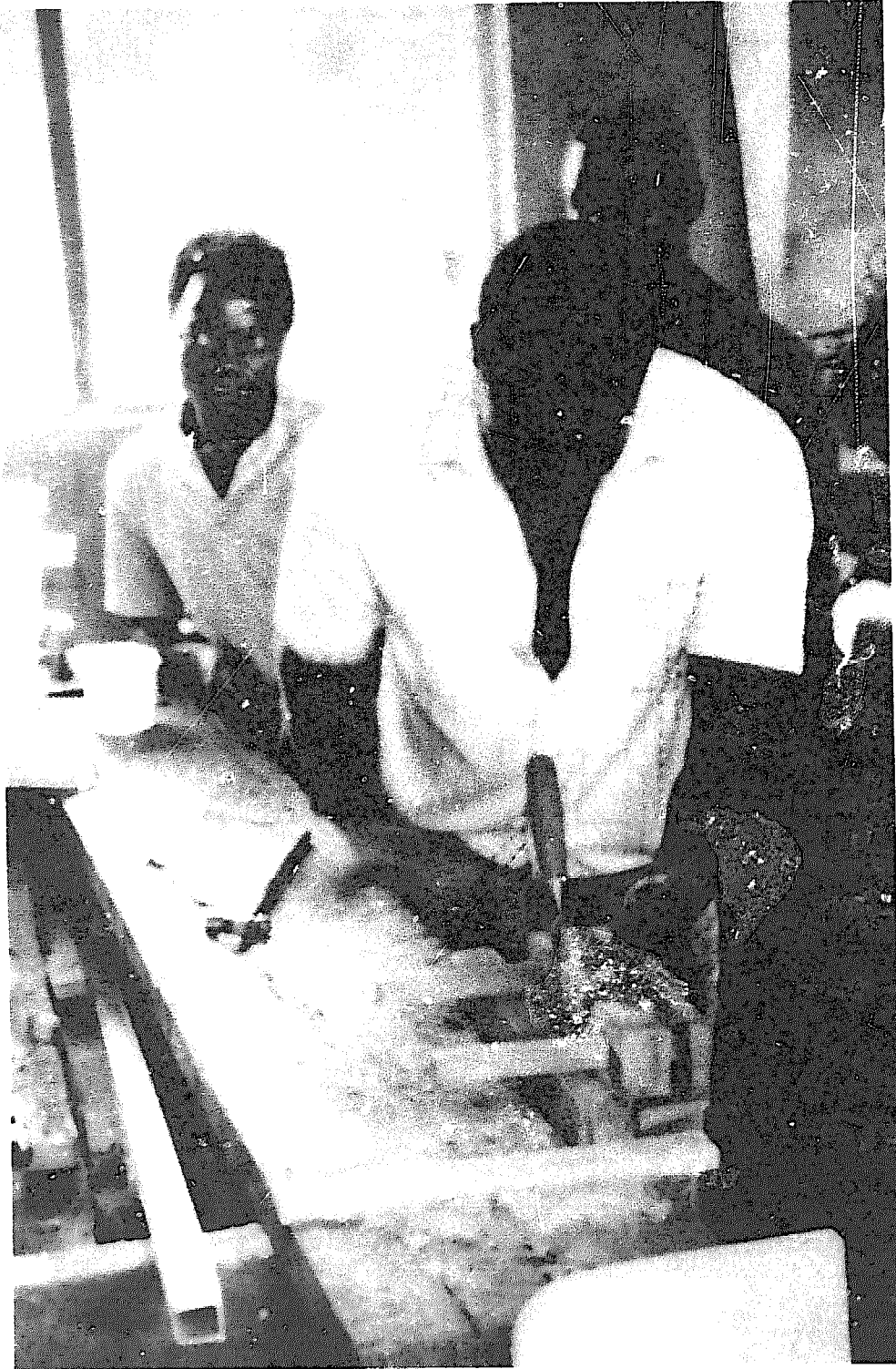

# Introduction

This manual describes in detail how to make seven different woodworking tools. Directions for their construction and use are in the form of step-by-step illustrations, backed up by short descriptive texts. Most of the information is supplied by the drawings, but it is important to read the captions carefully, because it is impossible to draw every detail needed for construction.

The tools described here are all very practical and cheap to make and include a JACK PLANE, REBATE PLANE, PLOUGH PLANE, SPOKESHAVE, SASH CRAMP, BENCH CRAMP and a type of BENCH VICE. All the planes except the jack plane are quite specialized tools, but they are essential pieces of equipment for a rural workshop, with no electricity, if it is to produce good quality work, efficiently. The cramps and vices are also essential. Without them, work cannot be cramped and glued properly, or held firmly enough for cutting joints accurately.

These tools have been developed to be made in situations where money is simply not available to equip a workshop with expensive, imported western tools. They are appropriate for both large training institutions, where the students can make tools for the school and for their own use, or for small village workshops where the craftsman can make his own tools as and when he needs them. It may even be possible to set up small tool-making businesses, supplying schools, colleges and shops in the surrounding area.

This is not a carpentry text book: I have assumed that the reader has a basic knowledge of woodwork, that he is capable of preparing timber to size, that he is familiar with a number of simple woodworking techniques, and has the enthusiasm to overcome setbacks and mistakes.

To begin with, a bench and a good kit of tools will be needed. This would include: TRY SQUARE, MORTISE GAUGE, JACK PLANE, HAMMER, CENTRE PUNCH, HALF-ROUND RASP, MALLETT, VARIOUS CHISELS, SCREW DRIVER, WHEEL BRACE, CARPENTER'S BRACE, a SET OF BITS and an OIL STONE. Not all of these tools are needed to make each design. It is up to the reader to decide which tools are made, bearing in mind the materials and equipment available, and the requirements of the workshop.

The quality of the tools described in this manual depend a great deal on the workmanship and materials used. In many cases the metal parts will have to be bought, but whenever possible use the best timbers, and take as much time and care in construction as you can.

None of these tools are perfect; they may require practise to use properly, they may even break — but compare the cost of a home-made tool and the cost of a similar tool in a shop. It may be up to one-third cheaper. Also consider the problem of a broken shop-bought tool: spare parts are expensive and often unobtainable in a developing country, and the cost of replacement will be greater than the original cost due to inflation. To repair a home-made tool may cost next to nothing. Of course there is nothing to stop you buying tools once your workshop is making money; on the other hand you may find it unnecessary. But in the beginning, is there any other way of starting out with little or no support?



# The tools

## Jack plane

Wooden planes take time and skill both to make and to use, but once the skills are mastered these tools can give a great deal of satisfaction. Treated with care and respect a wooden plane made from good quality hardwood will work as well as any metal plane. Eventually the sole will become worn, but it is a simple matter to true it up again with another plane. When the mouth becomes too large, a small piece of wood can be inserted in the front to fill the gap.

## Plough and rebate planes

Of the two, the plough plane is the most difficult to make, because of the metal sole plate. However if it cannot be made by a woodworker, it is definitely not beyond the capabilities of a rural metalworker.

Both of these tools have been designed so that a chisel can be used as the cutting edge, which means that even if one or two chisels do have to be bought, they will have a dual function in the workshop.

## Spokeshave

The spokeshave is a very versatile tool, and when used in conjunction with a bow saw or a coping saw can produce decorative and pleasing products.

As with the plough and rebate planes, it is not necessary to buy a blade specially for this tool; a normal jack plane blade will do the job adequately.

## Cramps and vices

All of the cramping tools described in this manual are made entirely of timber and use wooden wedges to apply pressure to the work piece. Take time to learn how to use these tools effectively without abusing the wedges with heavy mallet blows.

The leg vice, described on page 101, could be modified quite easily into a screw vice, using a length of threaded steel rod and a tommy bar, but this would be expensive.

The dimensions in this manual are all in millimetres, and for best results they should be adhered to quite strictly unless otherwise stated. Before making a tool, read through the text and follow the drawings until every detail is understood. In many cases the sequence of work is important.

Choose the timber to be used carefully. It must be hard, with close straight grains, no knots or splits, and it must be dry. The wooden parts of these tools can be finished with sandpaper and coated with linseed oil or varnish. Metal parts should have any sharp edges smoothed off with a file, and could be painted with enamel paint.

Hopefully the manual will stimulate ideas and imagination, and the reader will think twice before walking into a tool shop.

# Glossary

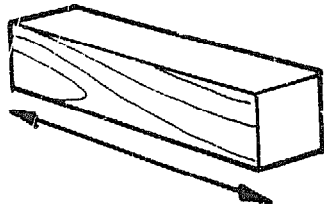

## Grain

The grain is the lines and patterns seen on the surface of a smooth piece of wood. The arrows show the direction of the grain.



## Wedge

A wedge is a piece of timber with its edges forming a shallow point at one end.



## Dowel

This is a small pin of wood with a round cross-section. It is often used to fix wood joints together instead of nails.

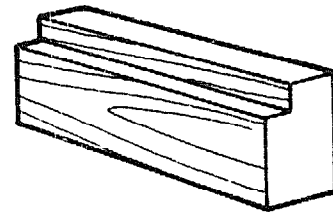

## Rebate

A rebate is a rectangular recess or step along the edge of a piece of wood.

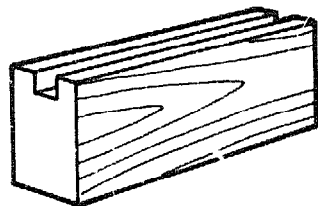

## Groove

A groove is a channel or a hollow cut into one side of a piece of wood.

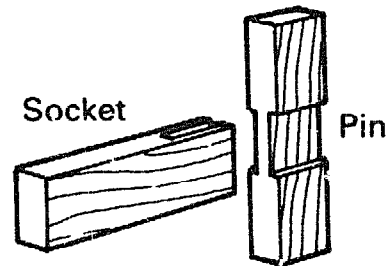

Socket

Pin

## Bridal joint

The two parts of this joint consist of a socket and a pin.

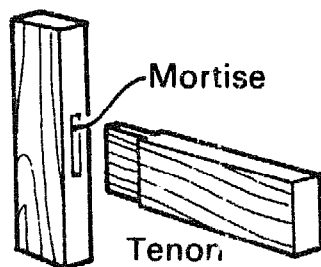

Mortise

Tenor

## Mortise and Tenon joint

This consists of two parts, the mortise, which is a square or rectangular hole, and the tenon, which fits securely into the mortise.

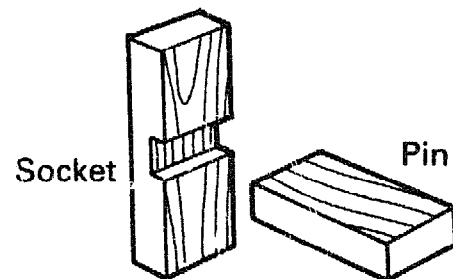

Socket

Pin

## Housing joint

The two parts of this joint consist of a socket and a pin.

## DRILLING METAL

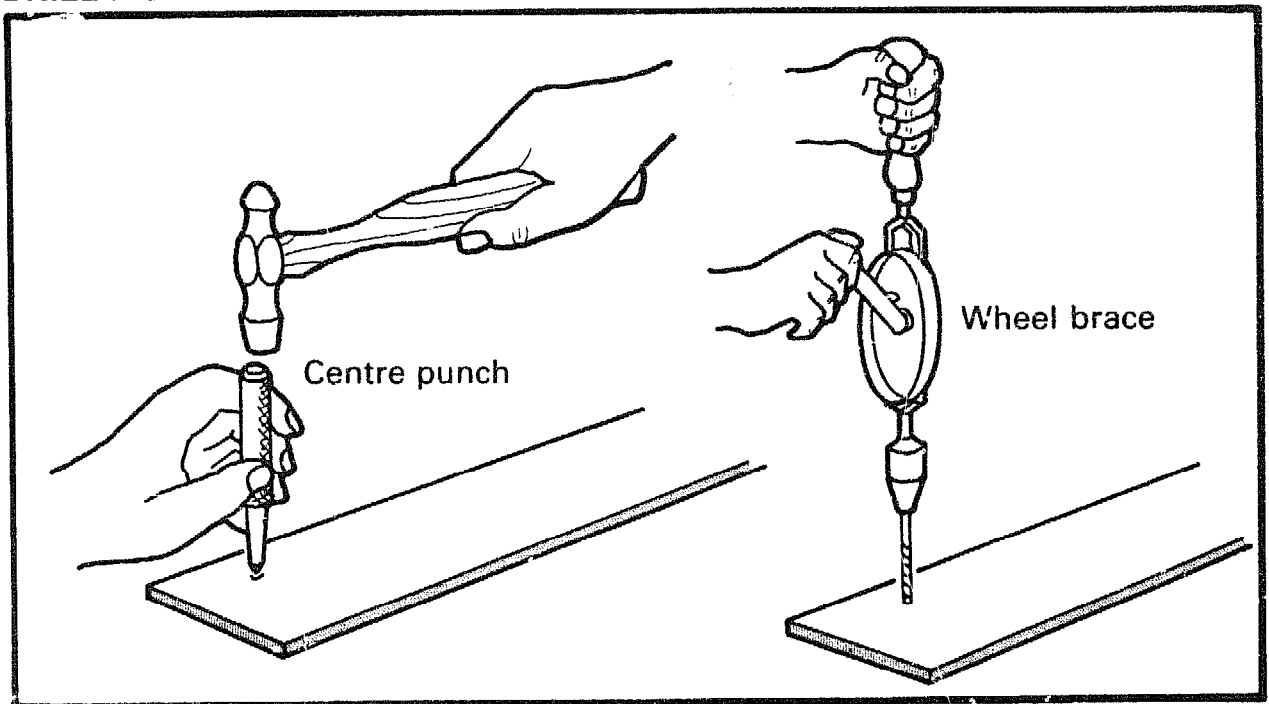

When drilling a hole in metal it is important to punch a small dent in the work piece to prevent the drill bit from wandering off the mark.

## FIXING TIMBER WITH WOODSCREWS

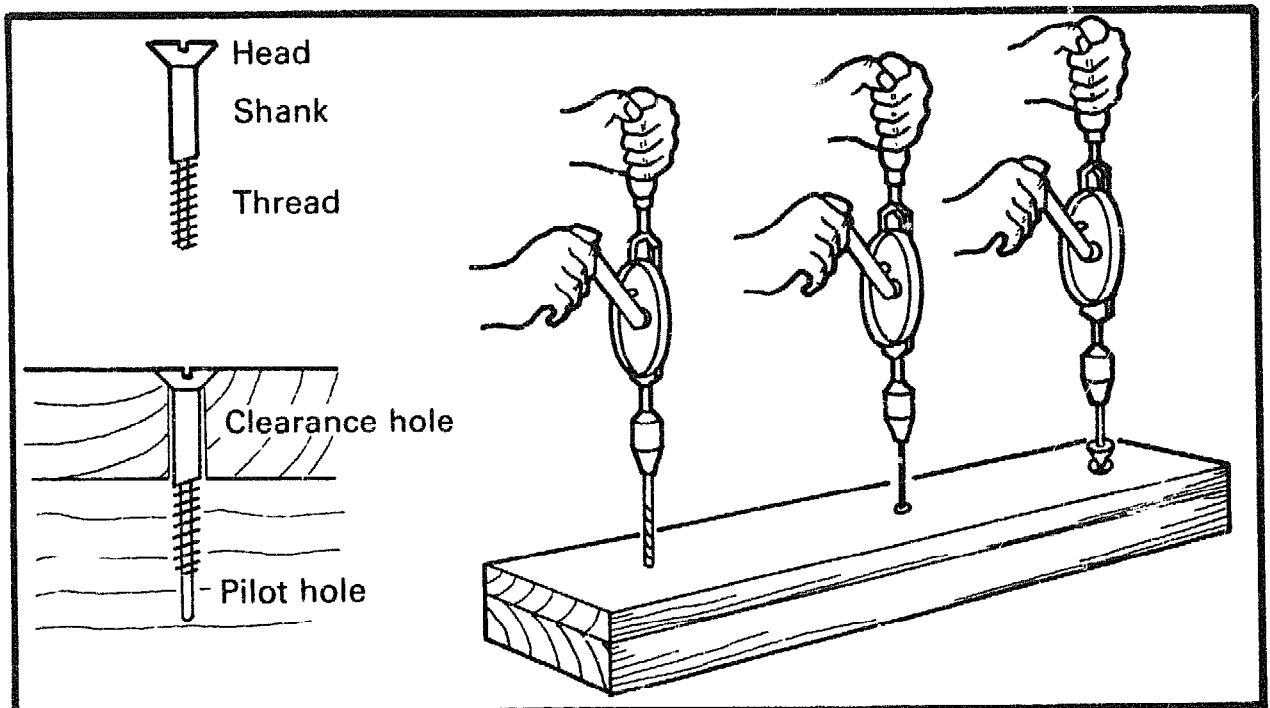

Woodscrews are used extensively in this manual for fixing parts of the tools together. In every case follow these instructions:

1. Drill a clearance hole through the top component, big enough to allow the shank of the screw to pass through easily.
2. Drill a pilot hole into the bottom piece. This should be small enough to give the thread of the screw a good 'grip'.
3. Countersink the top component for the screw head.

# Jack plane

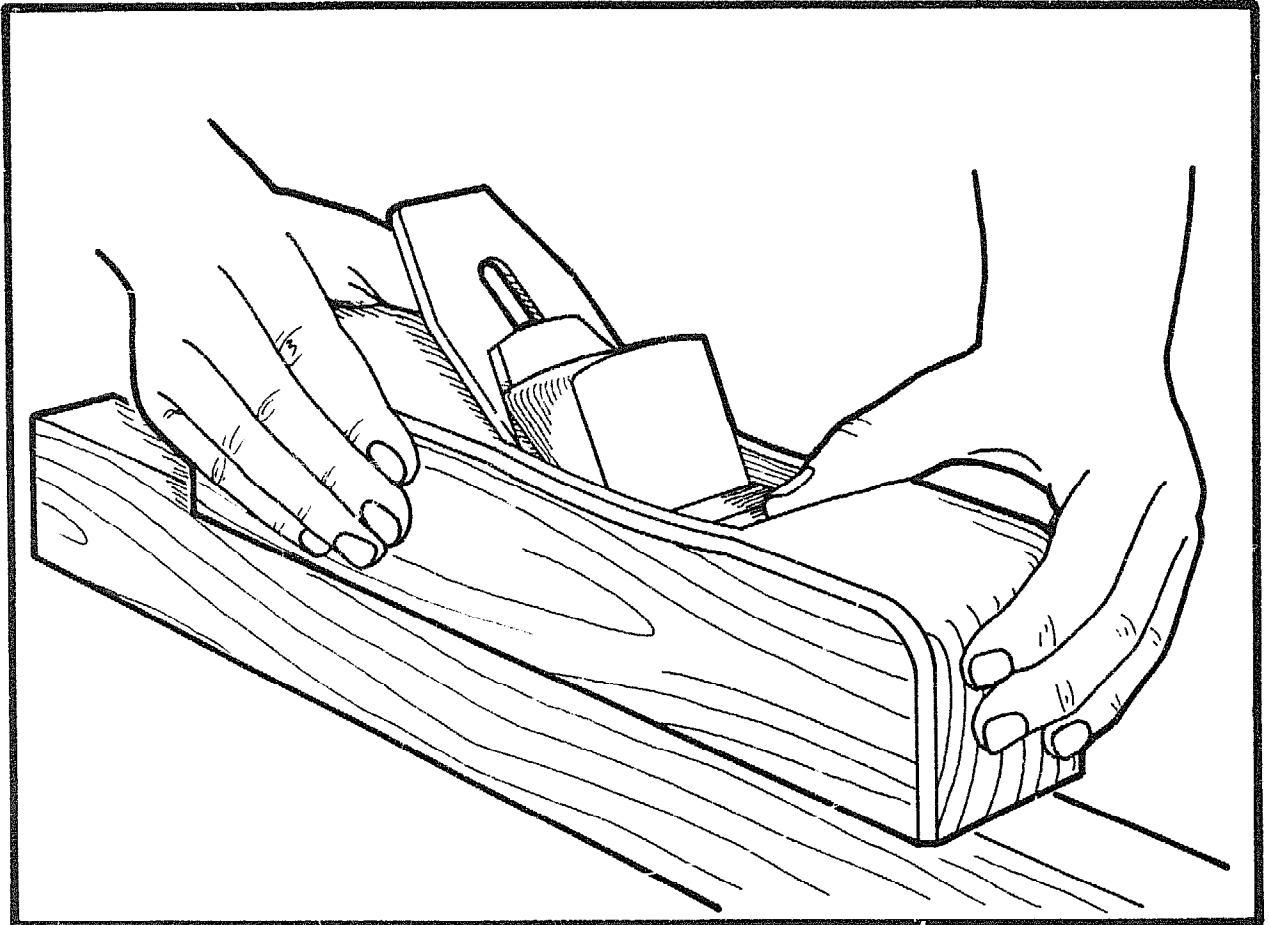

The jack plane is the most useful size of plane for general carpentry and joinery work. It can be used for preparing timber to size, trueing up boards for edge to edge joints, and for smoothing down jointed work after it has been glued together.

The dimensions given here can be altered quite easily to produce more specialized tools. To make a TRY PLANE, prepare the timber for the stock to about 500mm in length. For a SMOOTHING PLANE make the stock 200 or 250mm long. When altering the dimensions remember that the mouth opening should be  $\frac{1}{3}$  of the length of the plane back from the front.

Before you begin on this project it is important that a good plane blade and back iron is obtained, because this will determine the width of the stock. Also decide which design to follow. The first is a simple box-shaped plane, the second, a more complicated version with knob and handle.

The two most important aspects of plane making are to make the mouth opening the right size, and the throat big enough to allow the shavings to pass through easily.

Once the techniques for making this tool have been mastered it is a simple step to move on to more specialized moulding planes or low-angle block planes.

## LIST OF PARTS

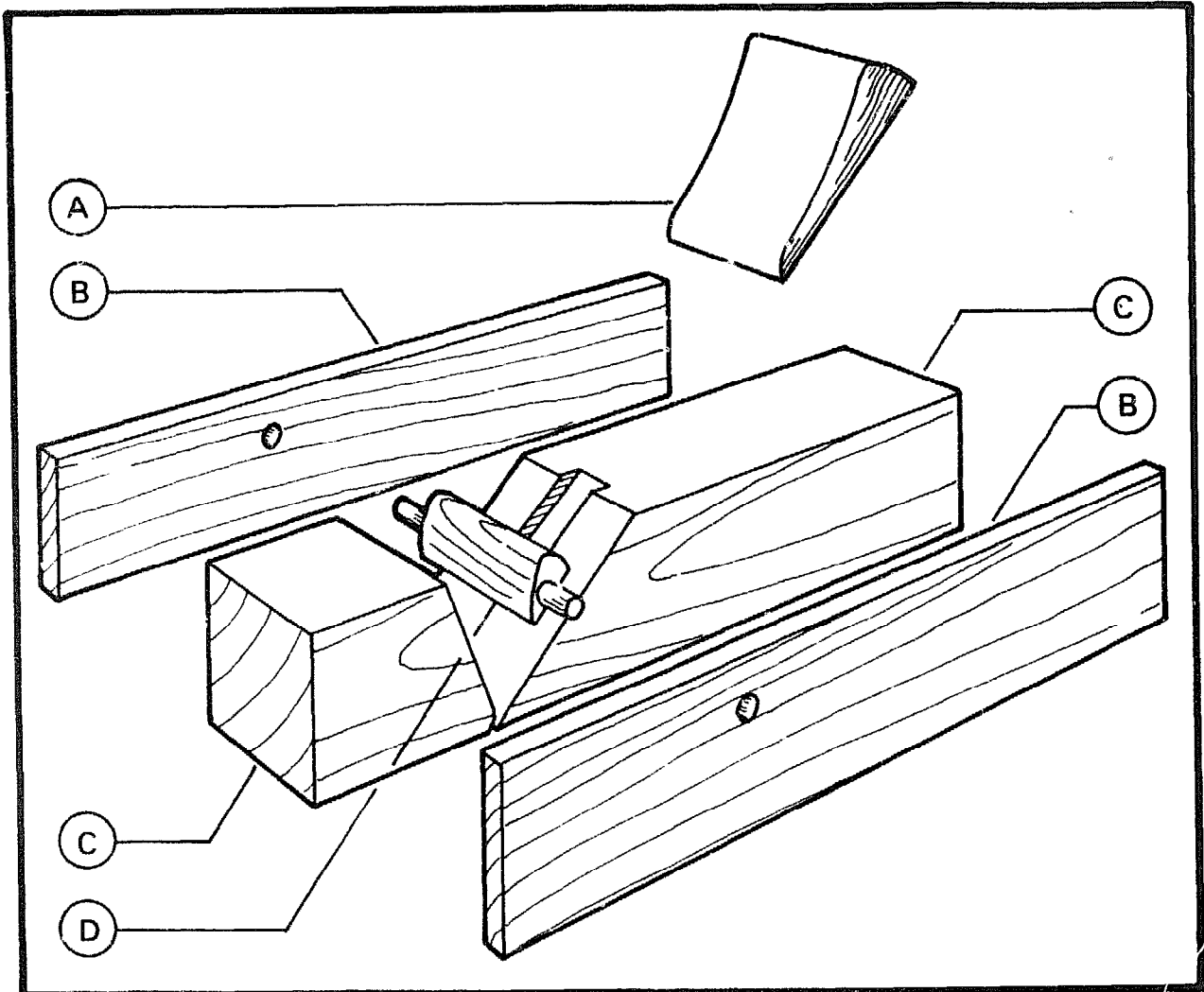

### Part

- A** *The wooden wedge* is shaped to fit between the wooden cross bar and the blade, which it locks tightly in position.
- B** *The side pieces* are glued to the central stock, and form part of the body of the plane.
- C** *The stock* is made from one piece of timber, cut and shaped to form the throat and the bed for the blade.
- D** *Wooden cross bar*. This is fitted into two holes in the side pieces. To make a really tight fit for the wedge it is essential it is allowed to move freely, so it must not be glued.

# CUTTING AND PARTS LIST

Part	Name	Quantity, Material and Dimensions (mm)
A	Wedge	1 pc. Timber $150 \times 25 \times \text{'Dim A'} + 34$
B	Side pieces	2 pcs. Timber $350 \times 75 \times 15$
C	Stock	1 pc. Timber $350 \times 75 \times \text{'Dim A'} + 4$
D	Wooden cross bar	1 pc. Timber $\text{'Dim A'} + 34 \times 30 \times 20$

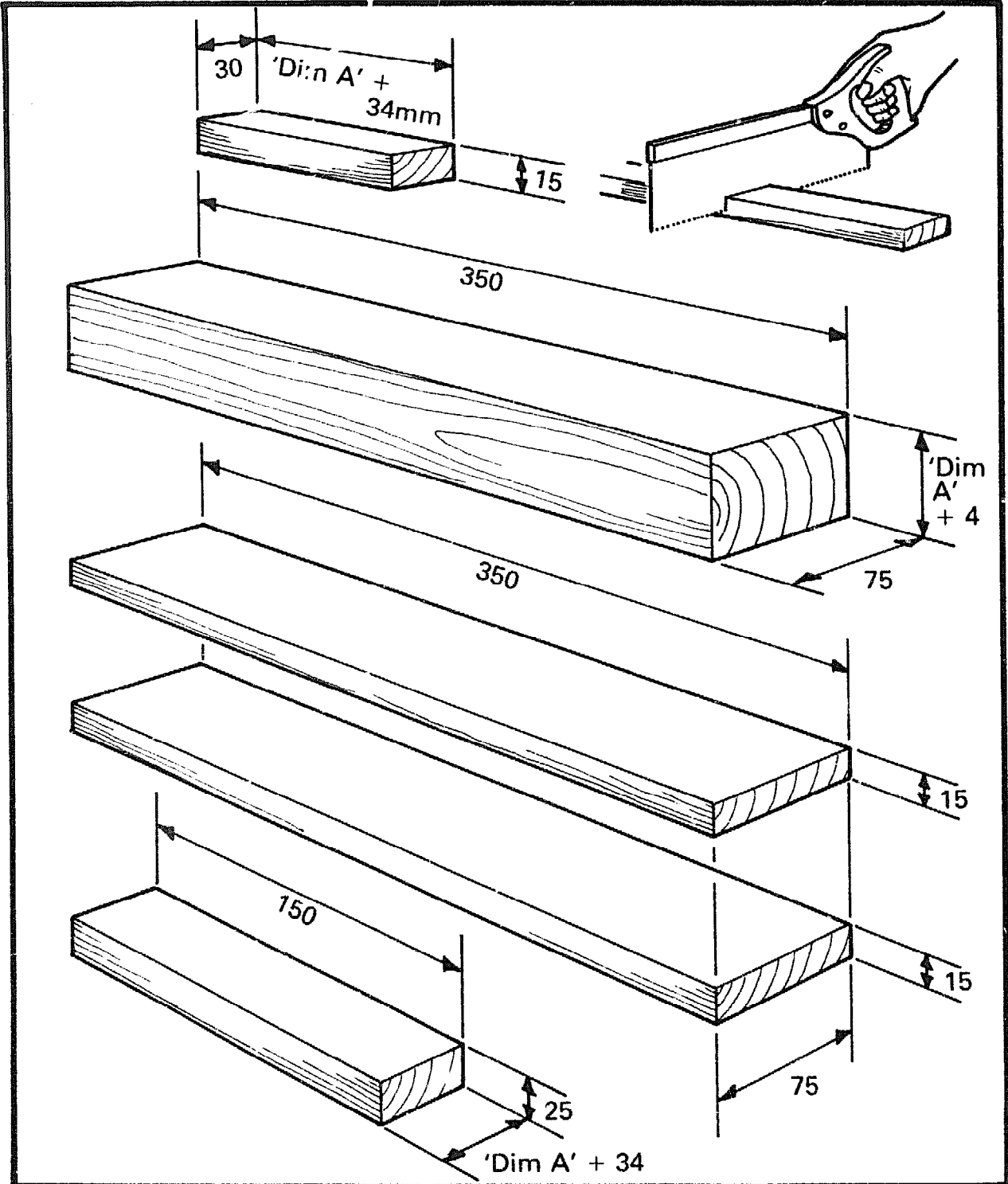
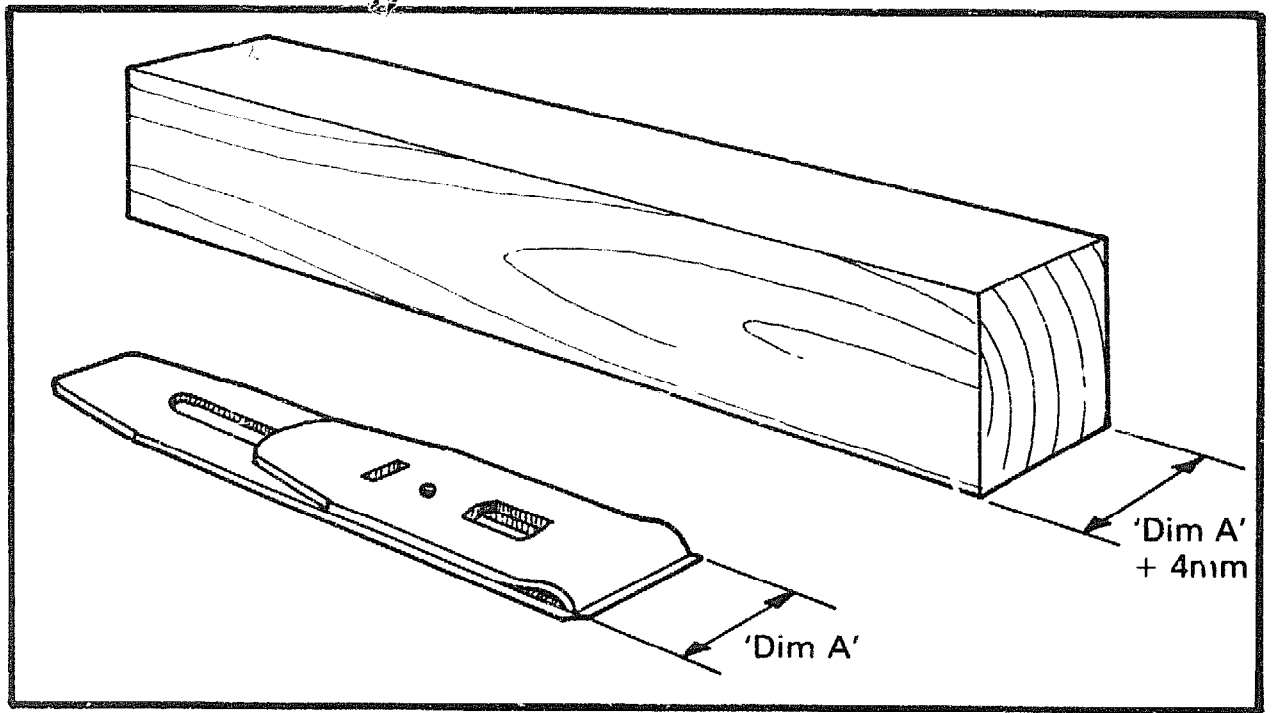

Diagram of cutting list.

'Dim A' refers to the width of the blade.

## MAKING THE STOCK



The width of the stock is determined by measuring the width of the blade and back iron to be used in the plane and adding on 4mm. Throughout these instructions 'Dim A' refers to the width of the blade.

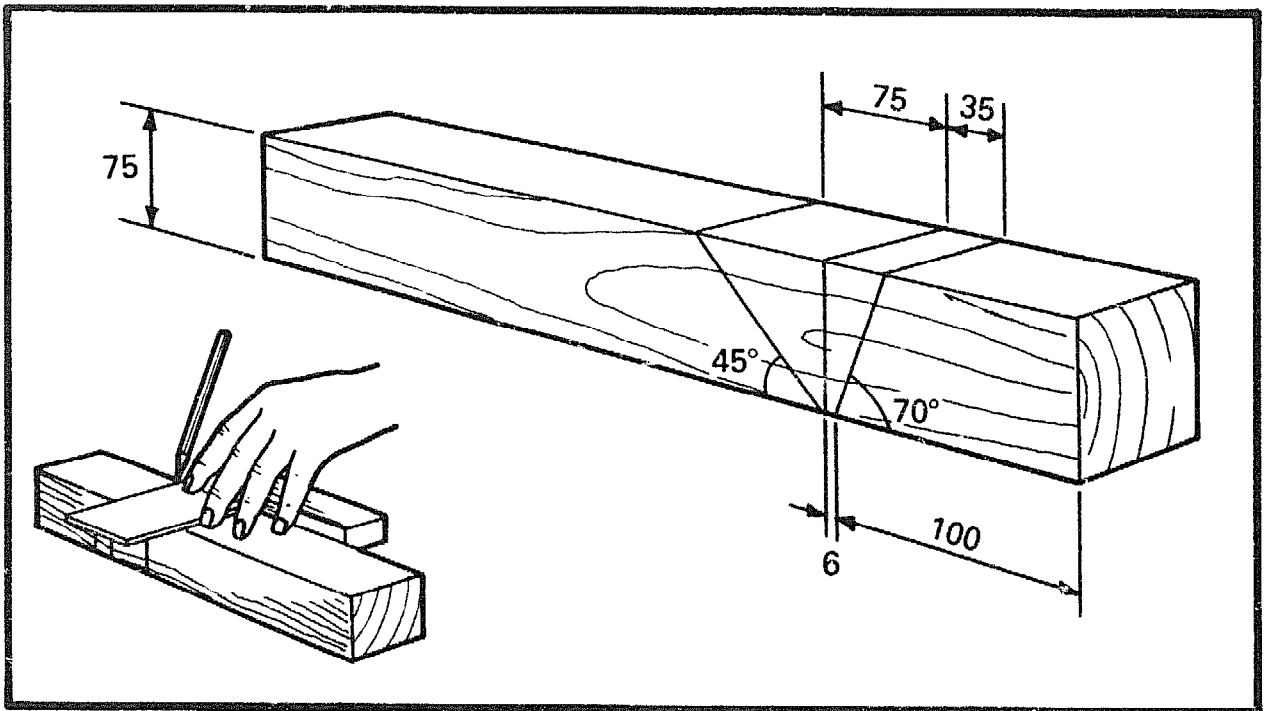

Take the timber prepared for the stock and square a line all round 106mm from one end. Choose the top of the stock and square a line 75mm from the first line, towards the back. Join the two lines on the top and bottom of the stock, to form an angle of 45° on both sides.

On the bottom of the stock square a line, 6mm from the first. On the top square a line 35mm from the first. Join these two up, on the sides, to form an angle of about 70°.

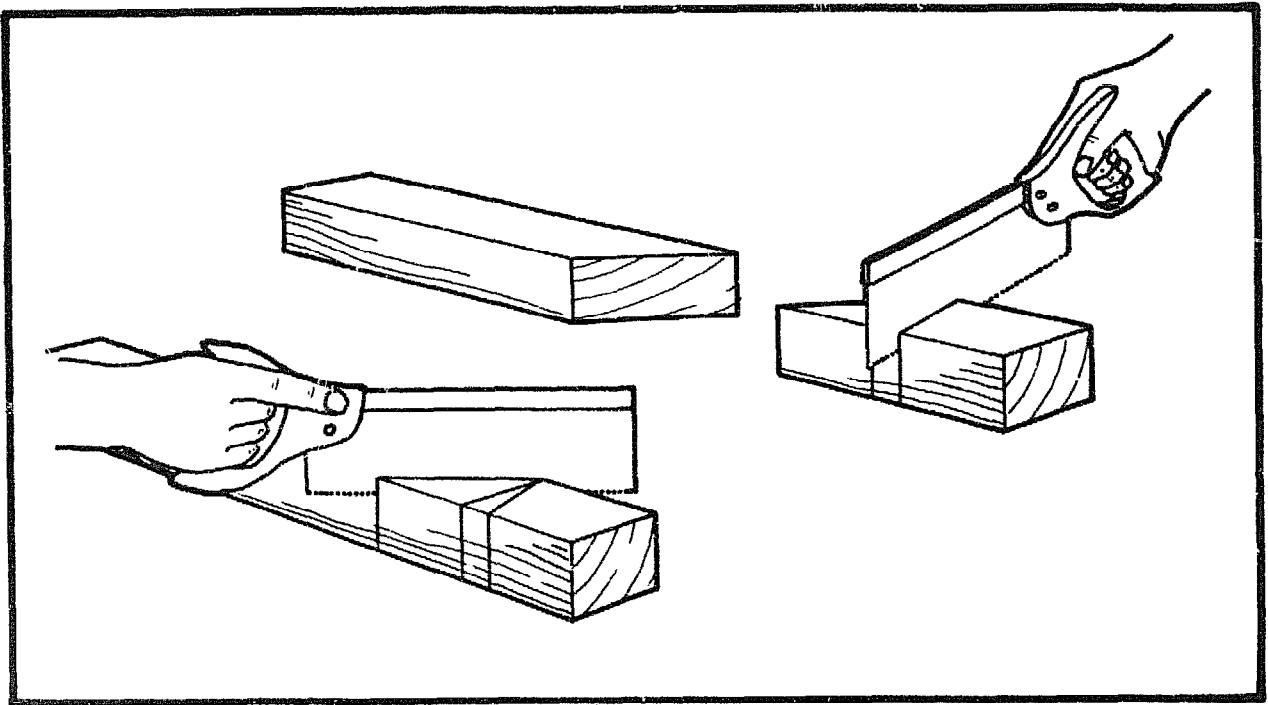

Cut the stock into three pieces. The centre section is waste, so take care to cut on that side of the line.

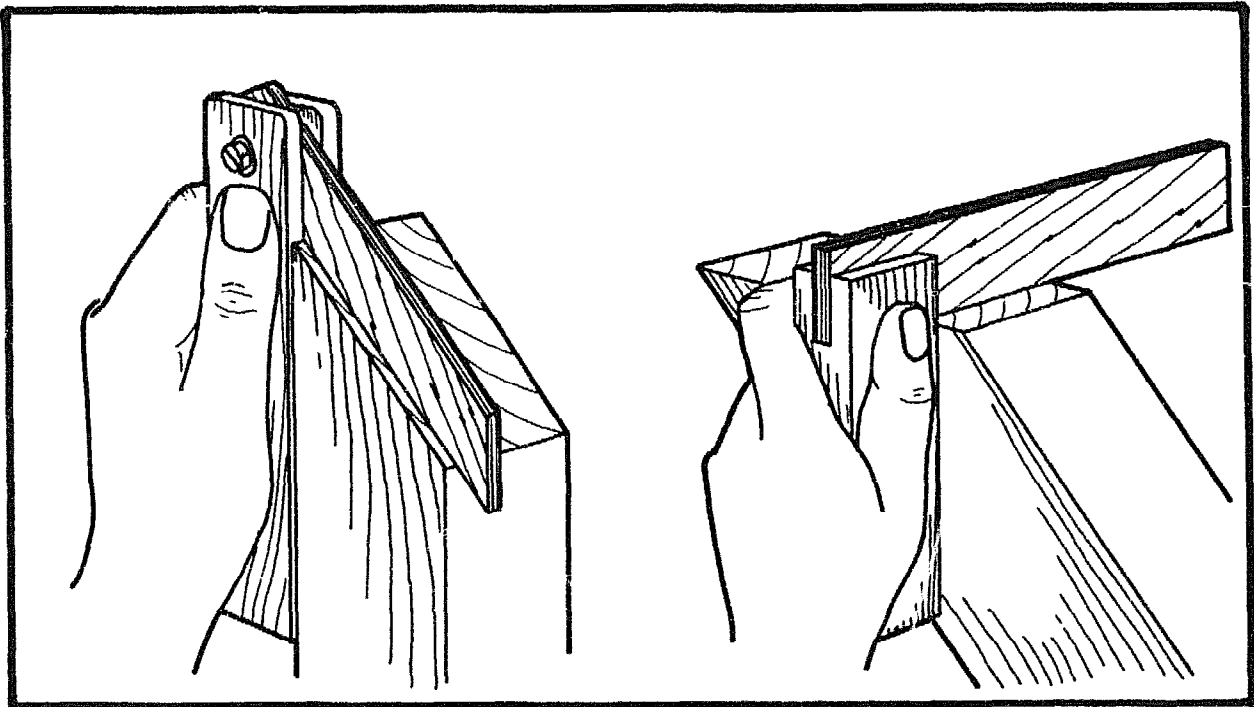

Take the largest section of the stock and plane the angled end, making sure it is square to the sides and at an angle of  $45^\circ$  to the bottom.



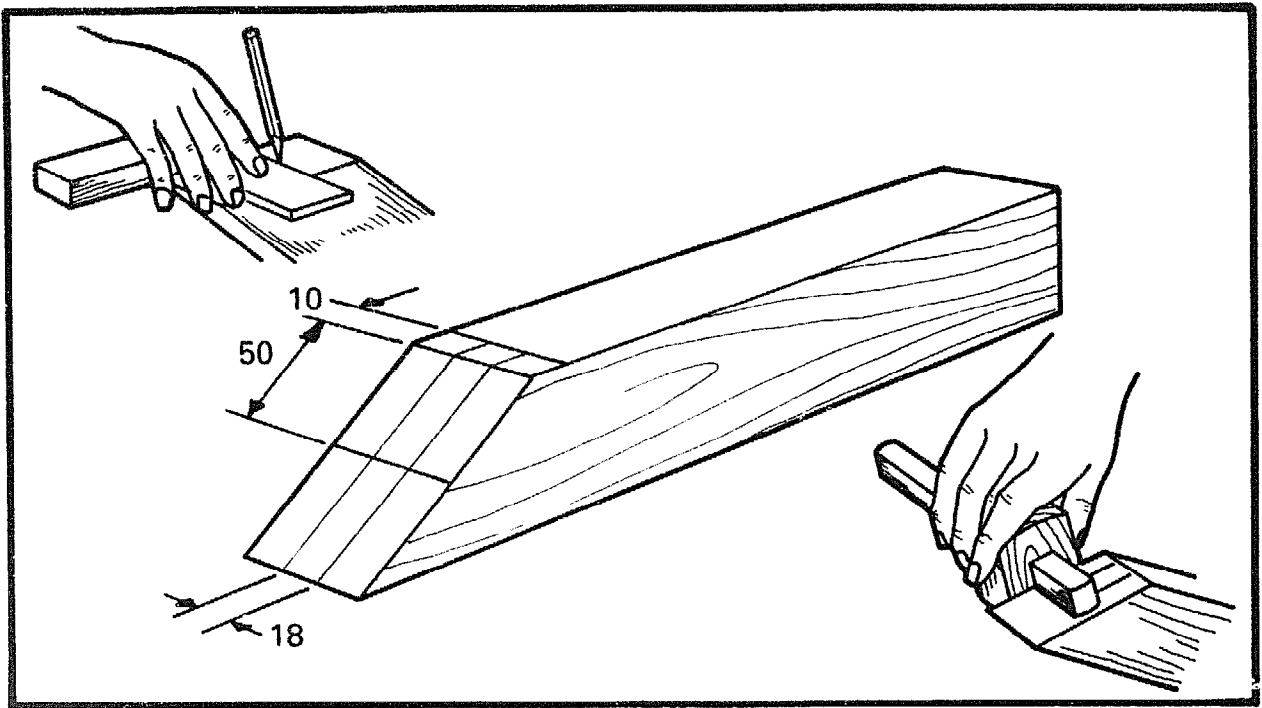

To mark the recess for the back iron screw, gauge two lines down the centre of the angled end, 18mm apart.

On the top of the stock square a line 10mm from the edge. On the angled end, square a line 50mm down from the edge.

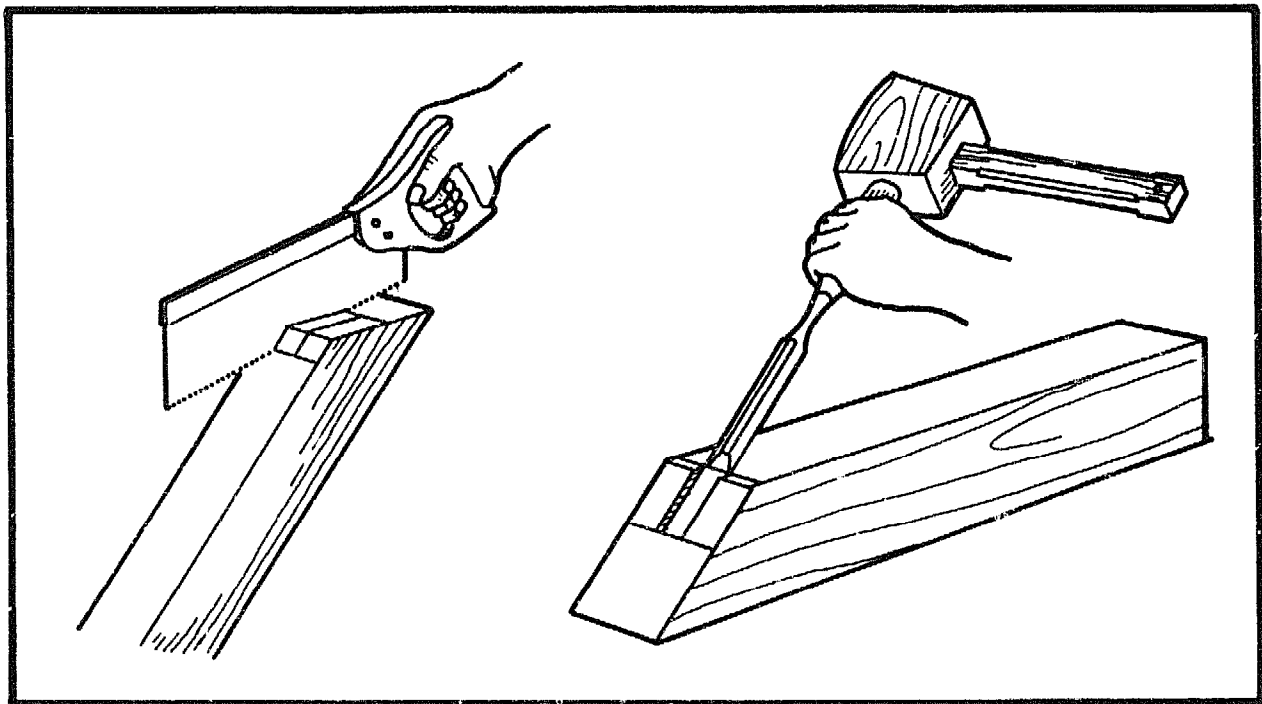

Saw the sides of the recess with a tenon saw and cut out the waste with a mallet and chisel.

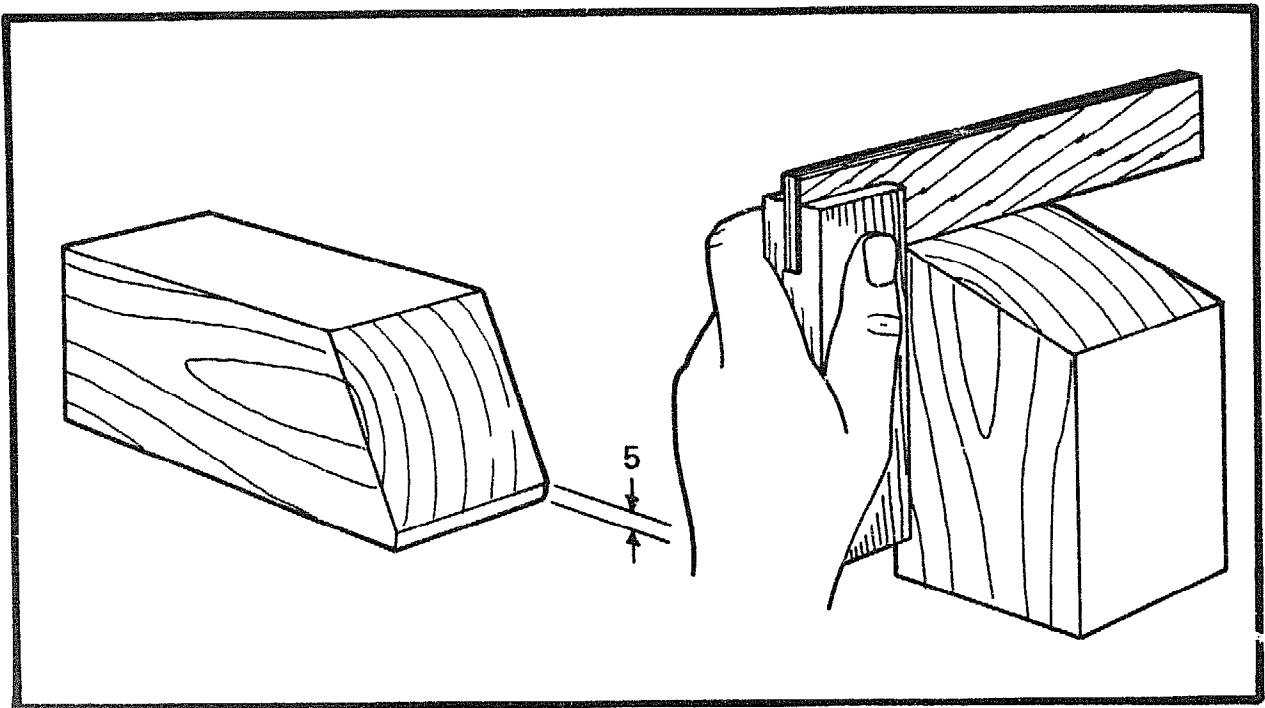

Take the smaller section of the stock and use a plane to square up the angled end, also round off the sharp edge slightly. This will prevent the mouth opening getting too big when the sole is trued.

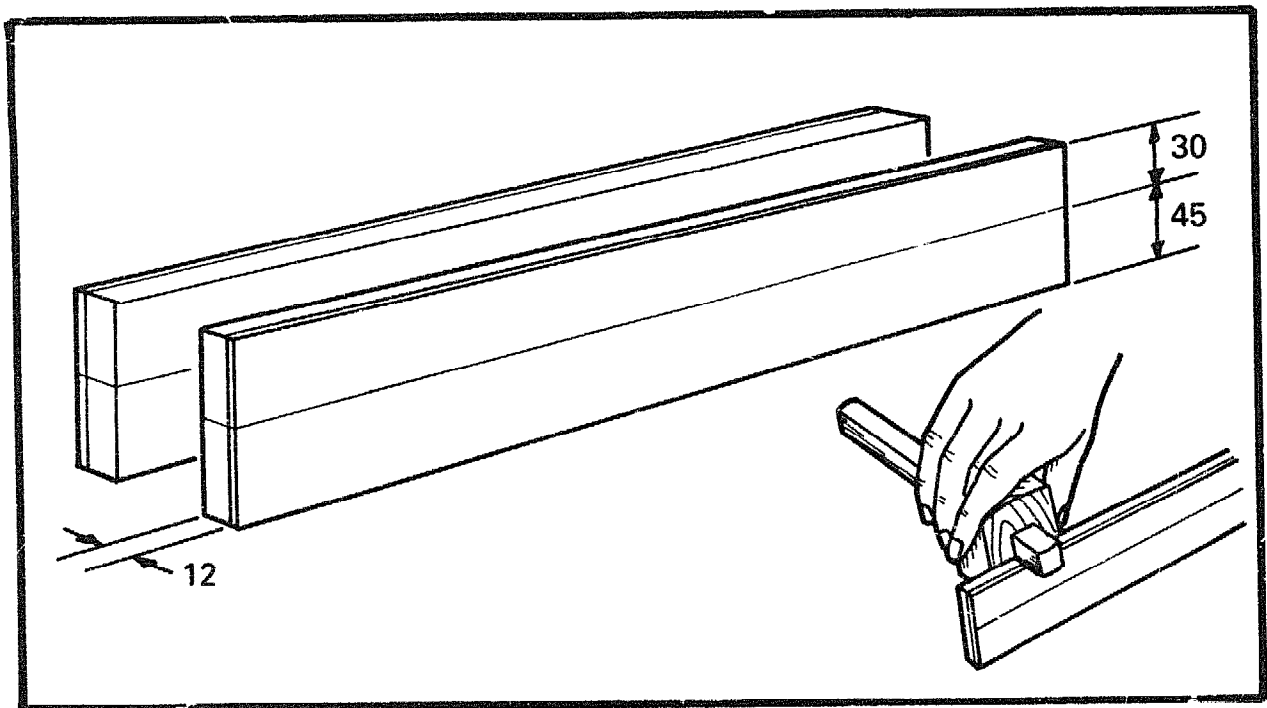

Take the two side pieces and gauge their thickness to 12mm. The waste will be planed off after the plane has been glued together. Also gauge two lines 45mm from the edge of both pieces.

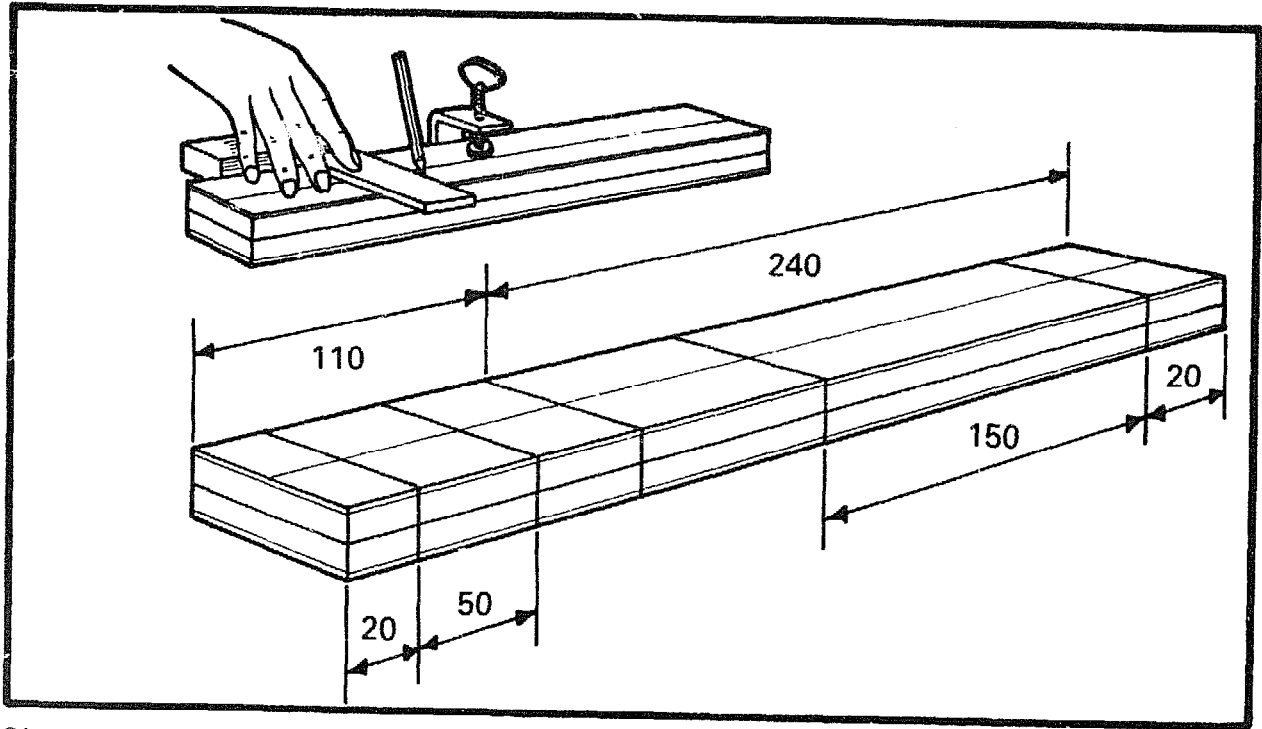

Clamp or nail the two side pieces together, and square a line all round 110mm from one end. Where this line meets the gauge line the hole for the wooden cross bar will be drilled.

Square the other lines all round as shown in the drawing.

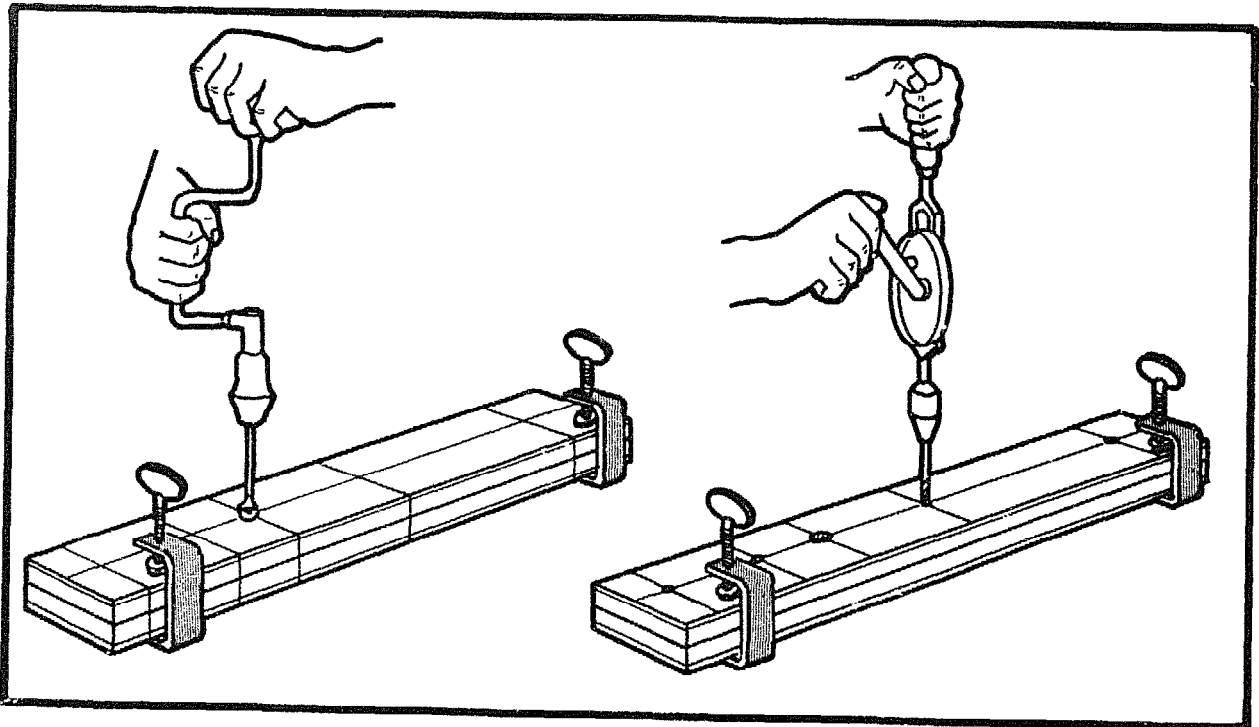

Keep the two side pieces clamped together. Use a brace and a 12mm bit to drill out the hole for the cross bar. Where the other lines intersect, drill 6mm holes. These are for dowels which will help in locating the pieces when the plane is glued up.

Always drill halfway through the workpiece, and turn it over to complete the hole.

## MAKING THE WOODEN CROSS BAR

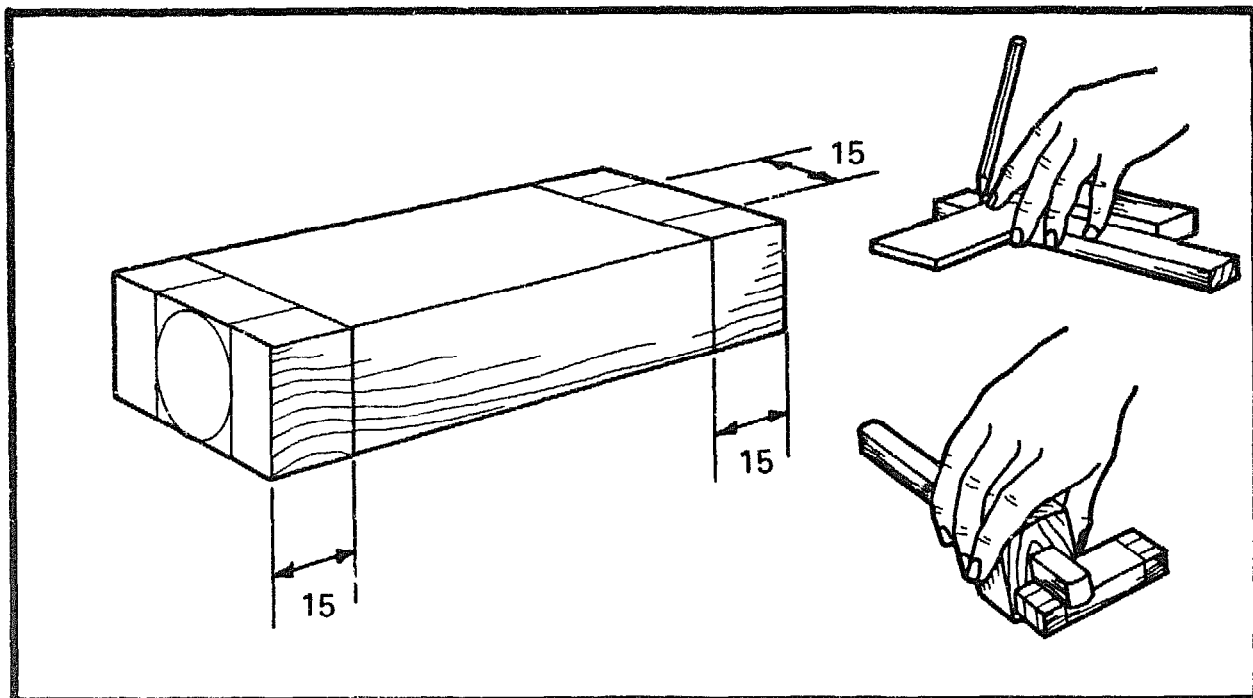

Take the timber prepared for the cross bar and square two lines all round 15mm from both ends.

Use a mortise gauge to mark 15mm tenons in the centre of both ends.

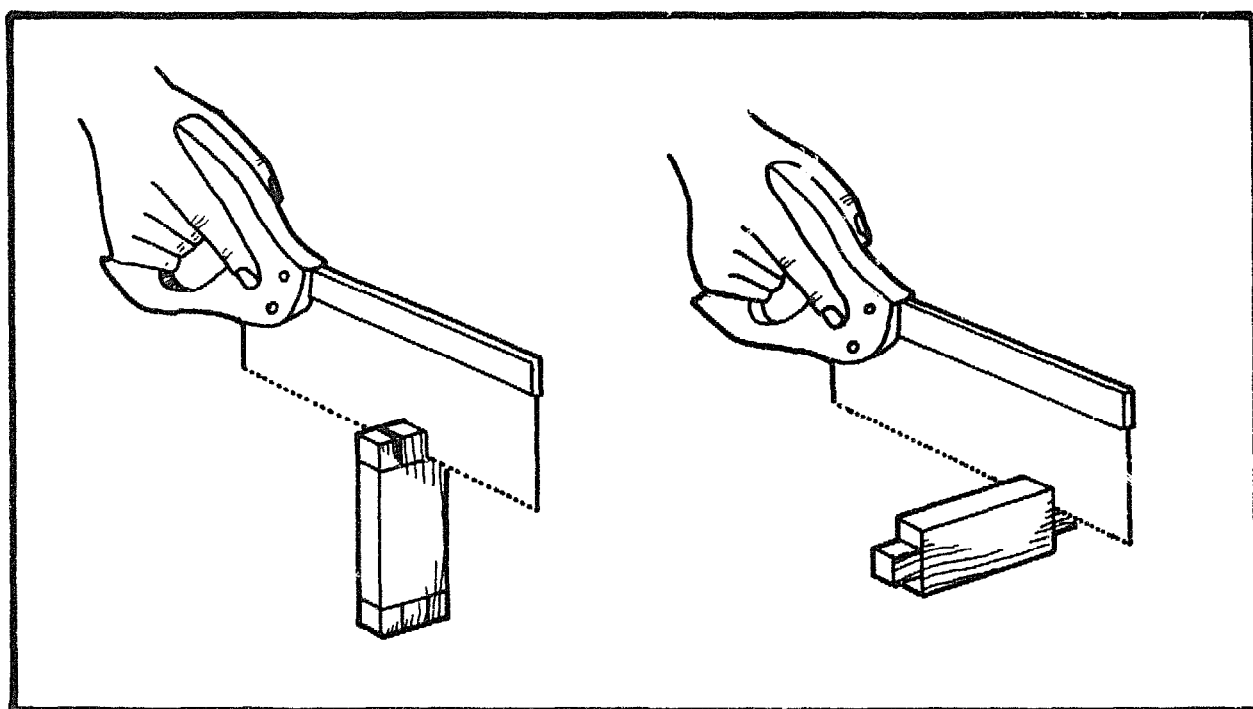

Use a tenon saw to cut the tenons on each end of the cross bar.

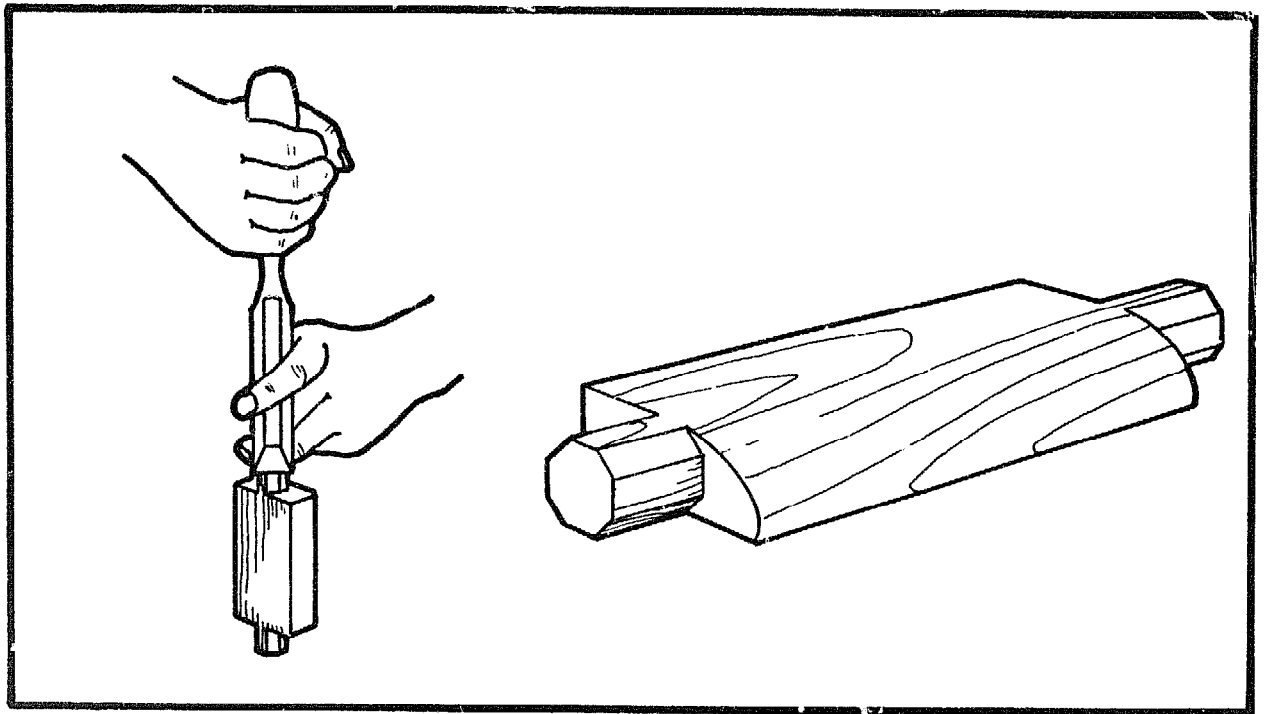

Use a chisel to pare down the tenons to an octagonal shape and make sure they fit tightly into the holes in the side pieces. Shape one edge to a rounded section to allow the shavings easy access out of the plane.

### ASSEMBLING THE STOCK

You will need at least five clamps to assemble the plane. If there are not enough available, there are instructions on page 20 for screwing the stock together.

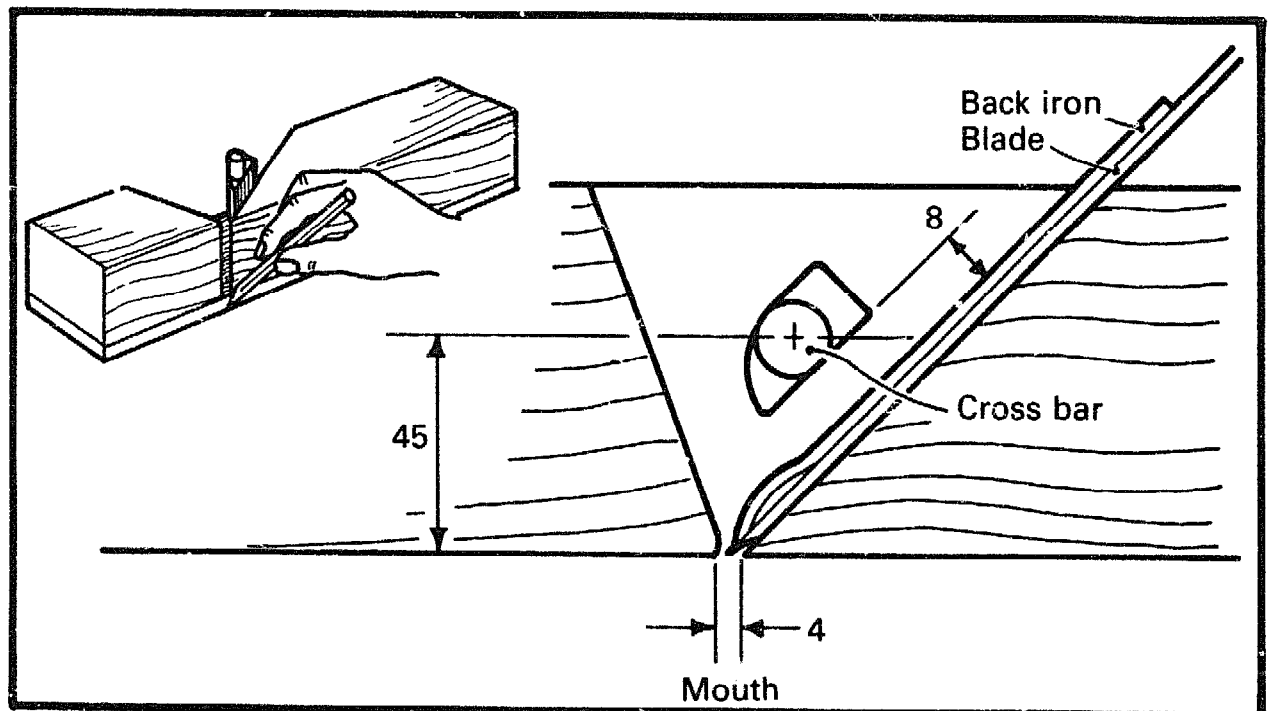

Take the two pieces of the stock and place them on one of the side pieces. Align all the pieces so that the distance between the back iron and the cross bar is 8mm, and the mouth opening is 4mm wide. Mark the position of the mouth on both side pieces.

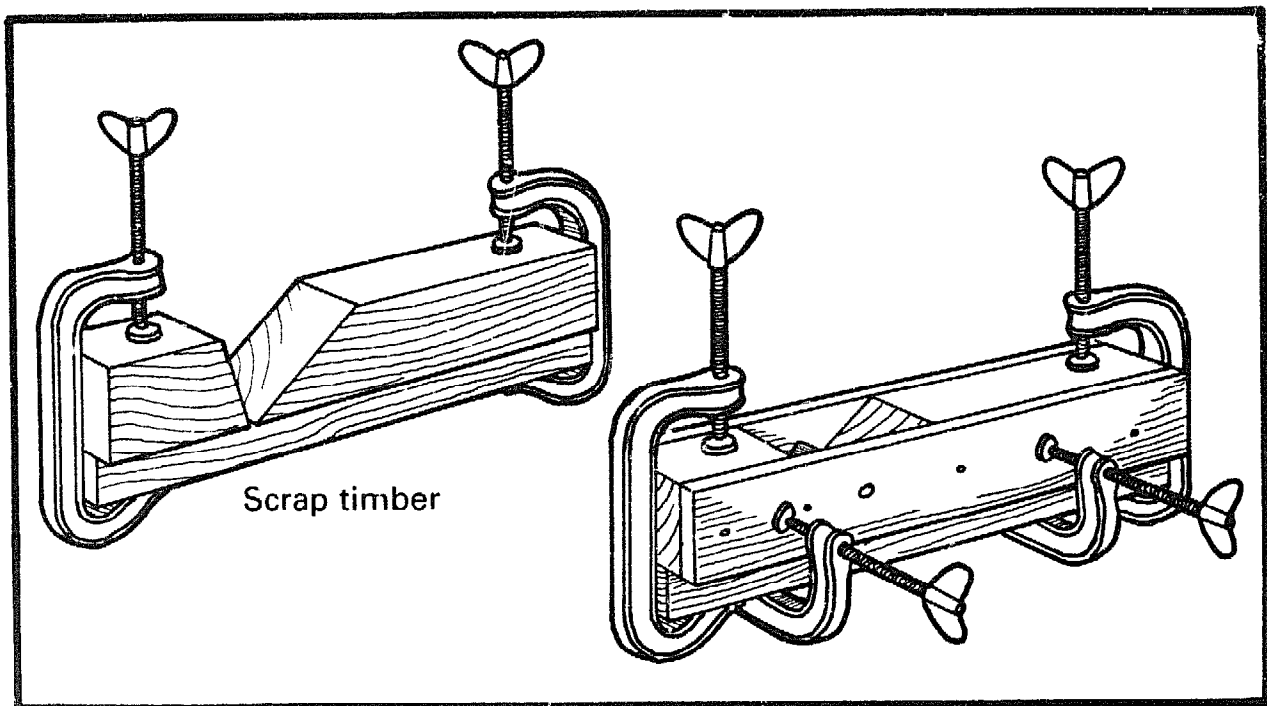

Take a straight piece of scrap timber and clamp it to the bottom of both pieces of the stock, leaving a gap of 4mm between the two parts of the stock for the mouth.

Insert the wooden cross bar into the two side pieces and clamp these onto the stock. Make sure everything is aligned properly and the cross bar is parallel to the mouth opening.

Prepare eight 6mm dowels 25mm long.

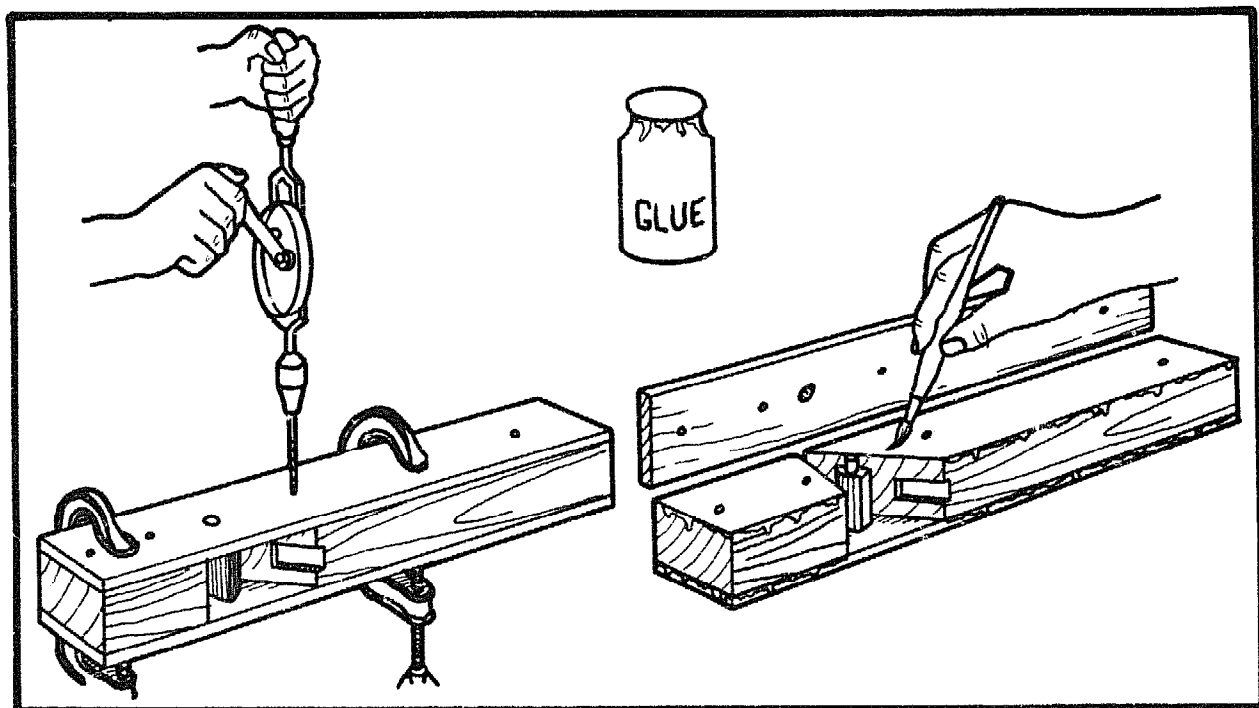

Use a wheel brace and a 6mm bit to drill into the stock through the eight holes in the side pieces.

Apply a good quantity of glue to the central parts of the stock only and assemble the pieces. **Do not forget the cross bar.**

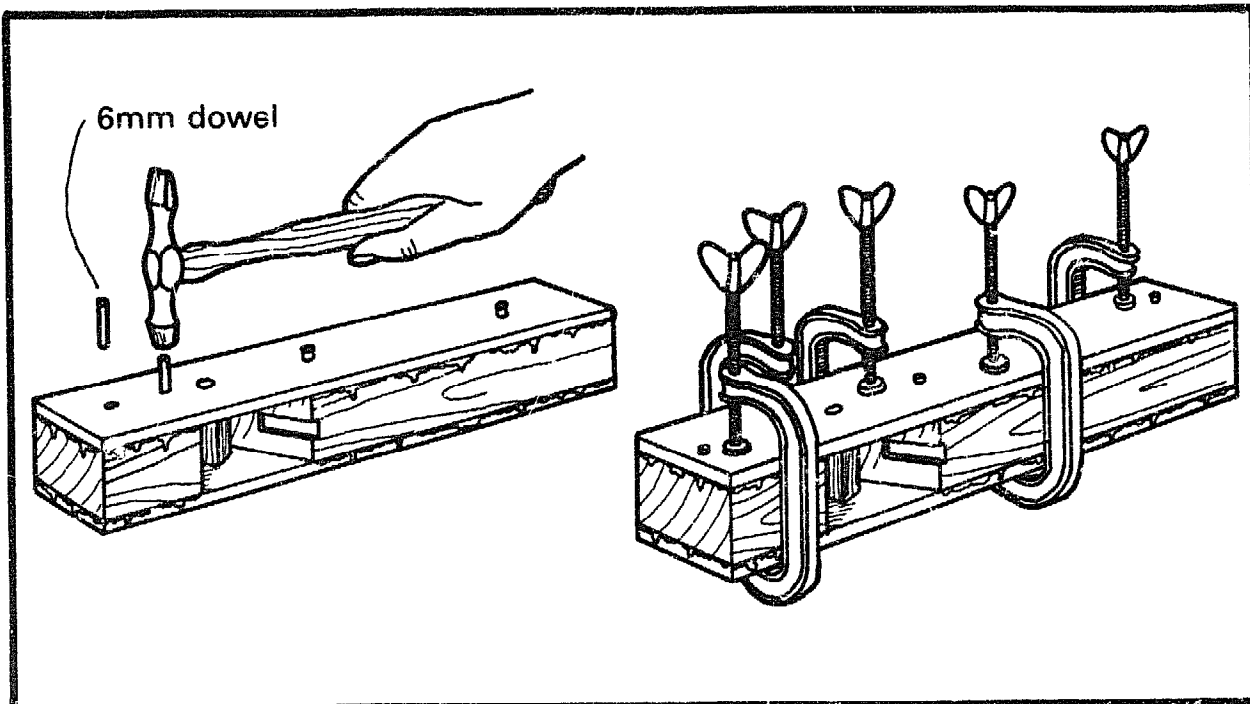

Drive the dowels into the stock and clamp the assembly together with as many clamps as possible. Leave the glue for at least six hours.

### MAKING THE WEDGE

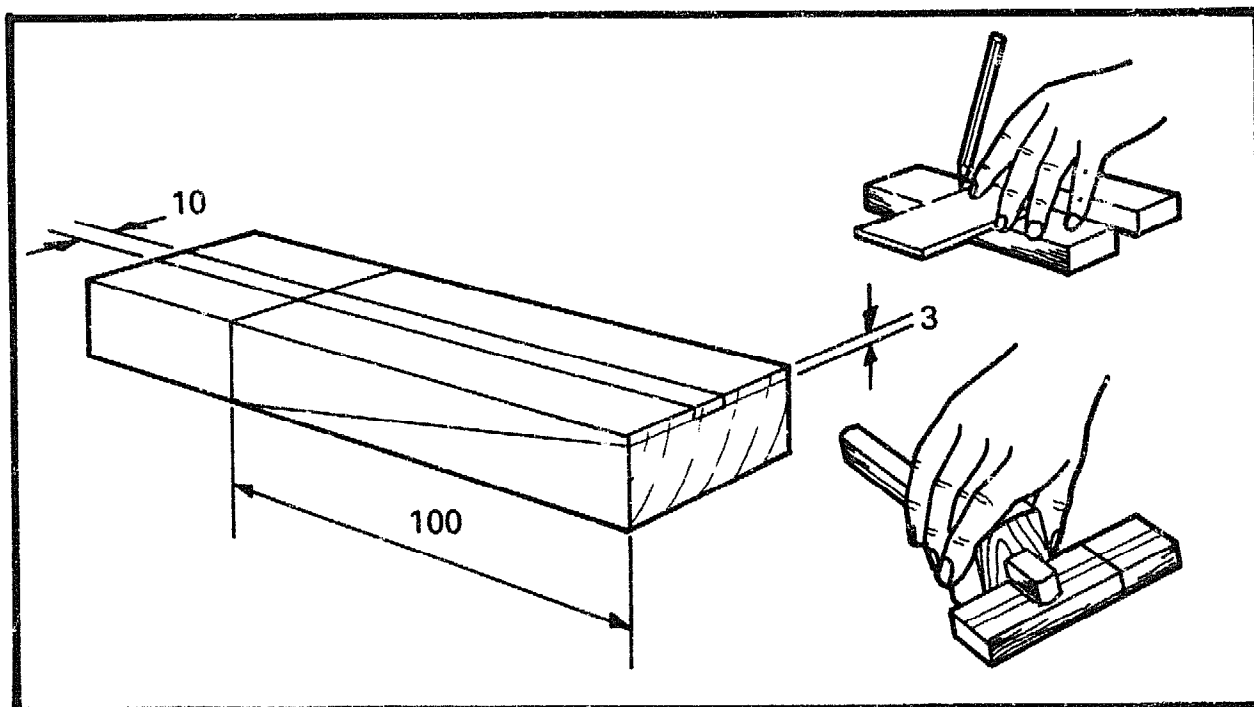

Take the timber prepared for the wedge and square a line 100mm from one end. Mark the shape of the wedge by drawing a diagonal on both edges.

Mark the groove for the back iron screw with two lines 10mm apart on one side only.

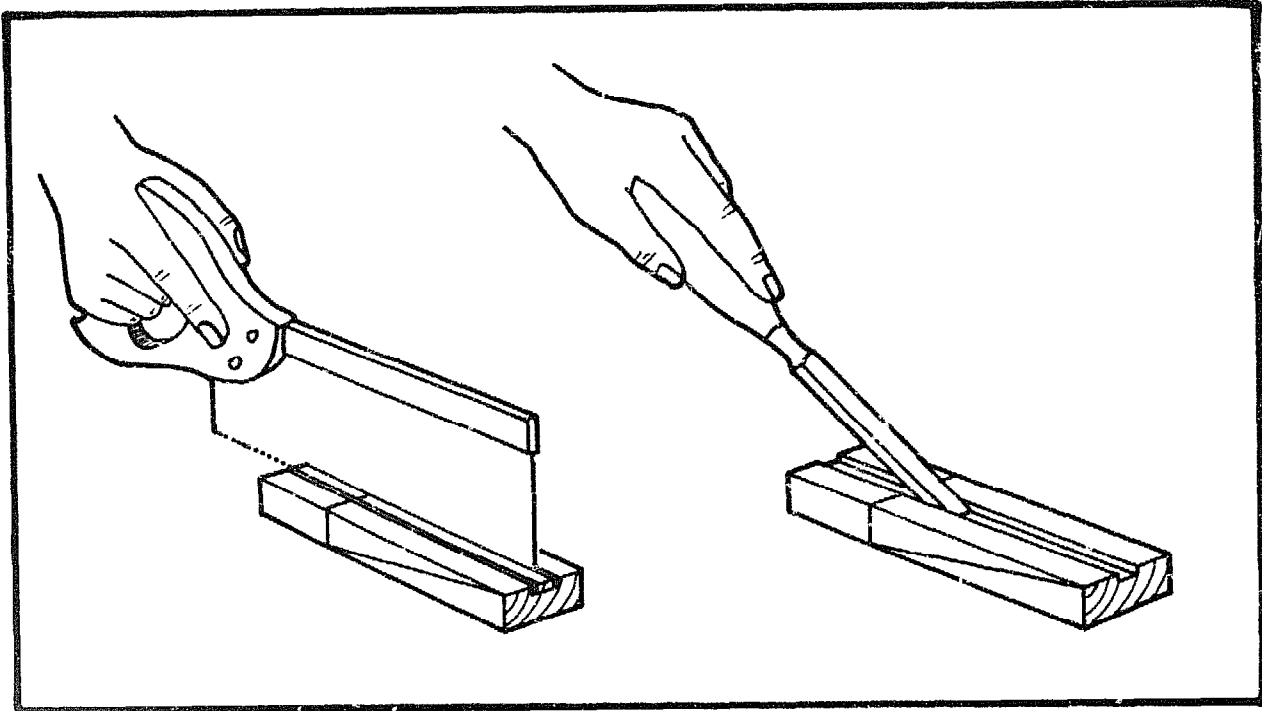

There are three ways to cut the groove:

1. Use a plough plane if one is available.
2. Use a cutting gauge, and remove the waste with a chisel.
3. Use a tenon saw to cut the sides of the groove and chisel out the waste.

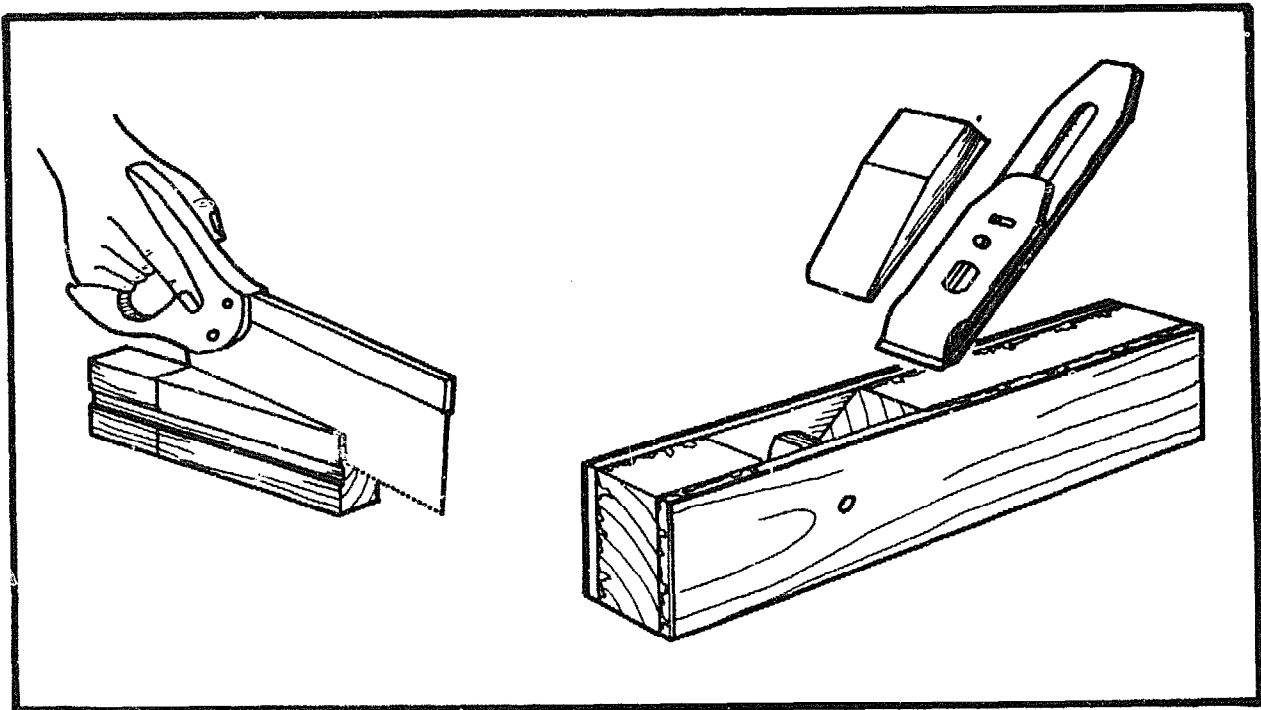

Saw the wedge to shape.

Take the blade, back iron and wedge and fit them into the throat of the plane. Take time to make the wedge fit tightly. It will need to be planed smooth, and may also need rounding off on both sides of the sharp edge.



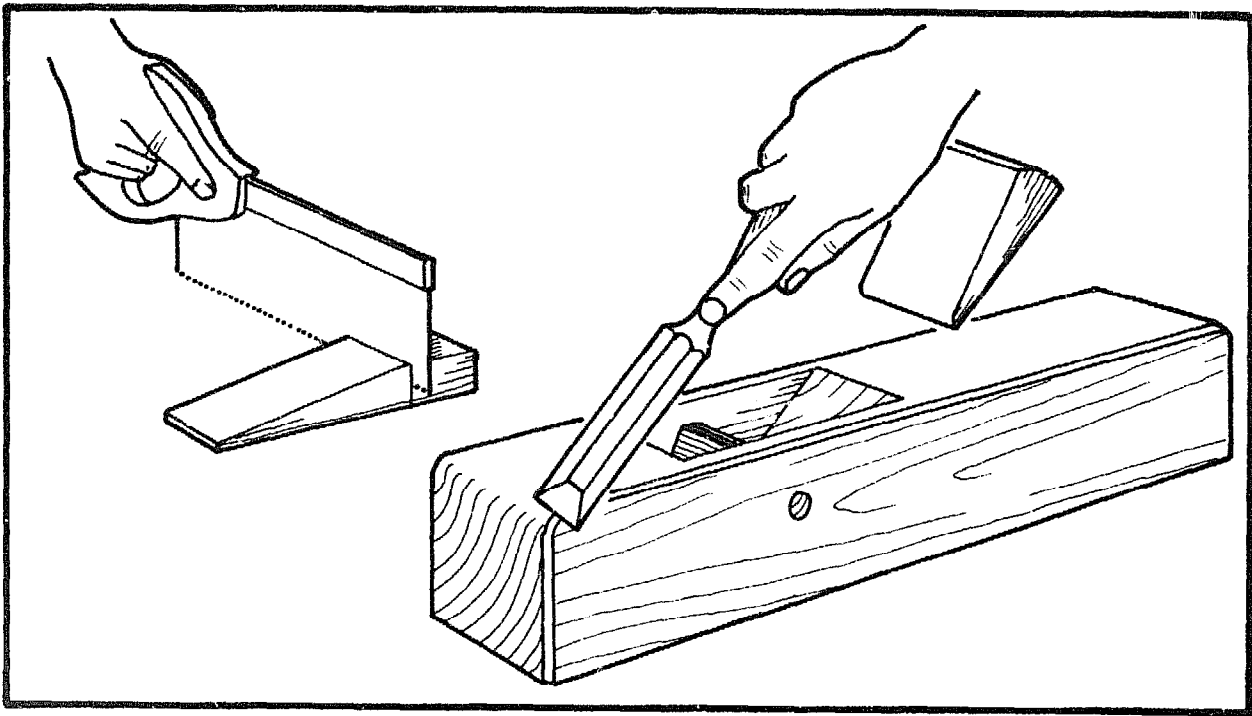

Saw off the top end of the wedge so it is about 100mm long.

At this point the reader must decide whether to carry on and make the plane on page 21, or stick to the simpler version. In the latter case the stock must be planed smooth and all the edges rounded off to make it comfortable to hold.

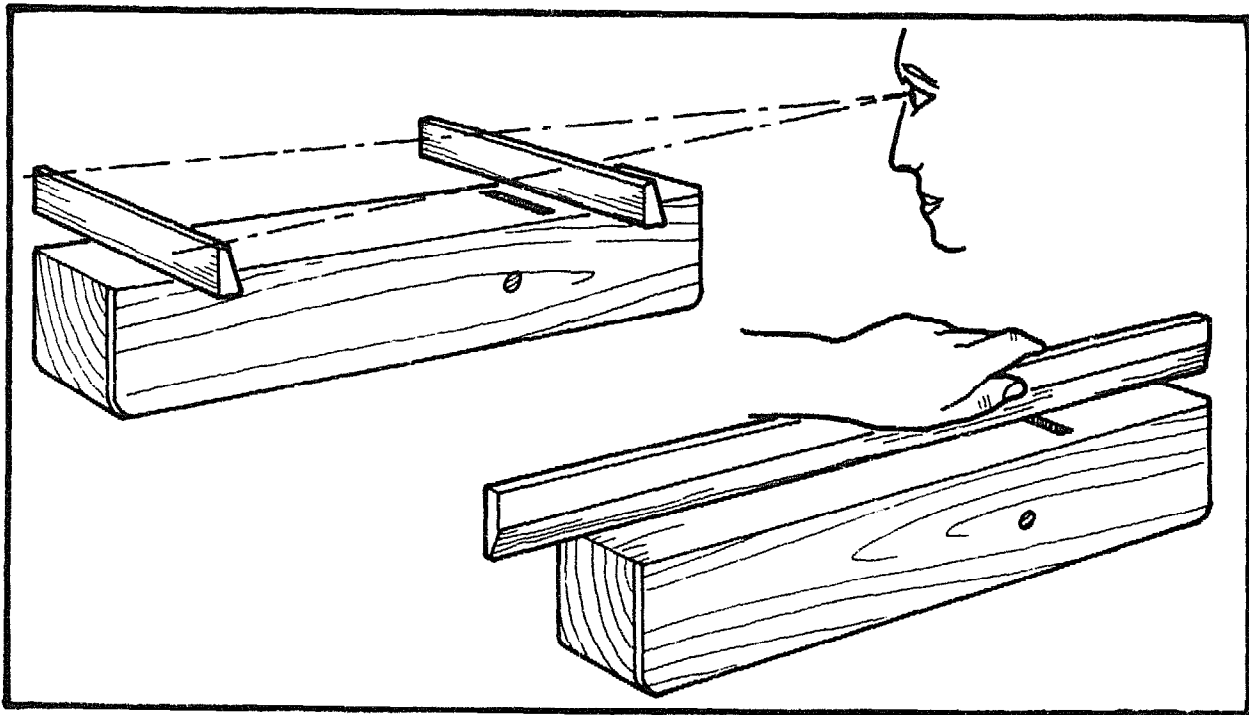

Plane the sole of the plane very carefully so that it is straight and free from winding. The mouth opening should be no wider than 5mm.

## SETTING THE PLANE

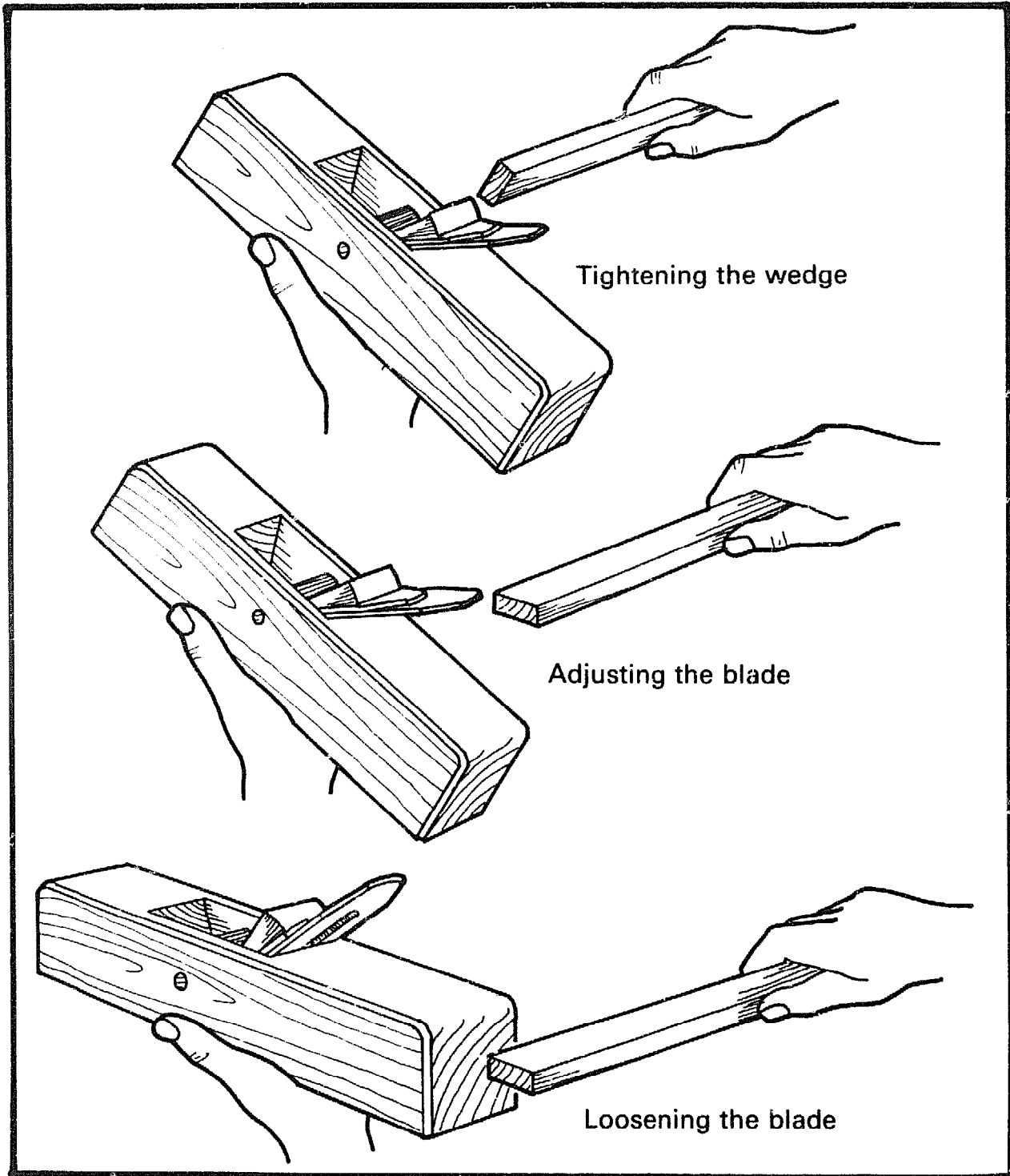

To tighten the wedge and the blade, strike the wedge with a piece of wood or a mallet.

To adjust the blade forward, strike the back of the cutter.

By hitting the back of the plane, you loosen the wedge and also bring the blade back.

## ALTERNATIVE METHOD OF ASSEMBLY

If there are not enough clamps available, the plane body can be glued and screwed together. Later the screws can be replaced by dowels.

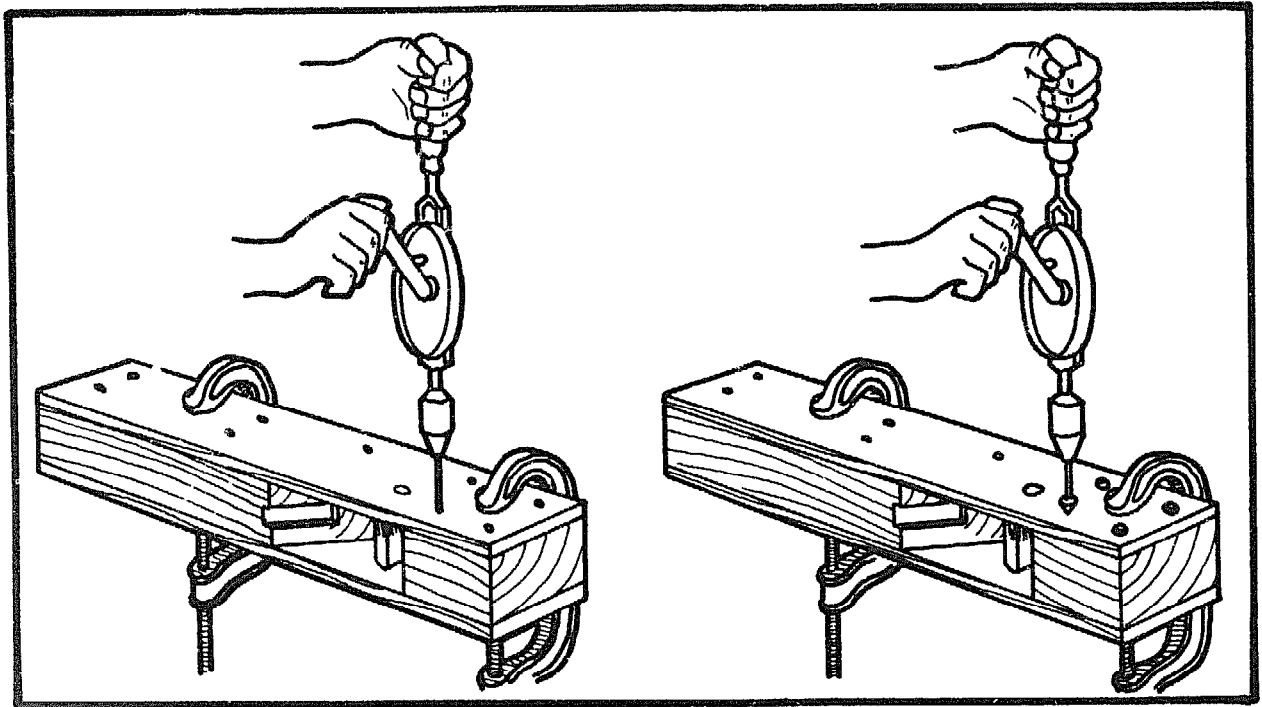

Align and clamp the parts together. Mark the position of the screws, taking into account the final shape of the plane. Use about eight or nine screws per side. Drill clearance holes for the shanks in the side pieces, pilot holes in the stock for the threads, and countersink for the heads.

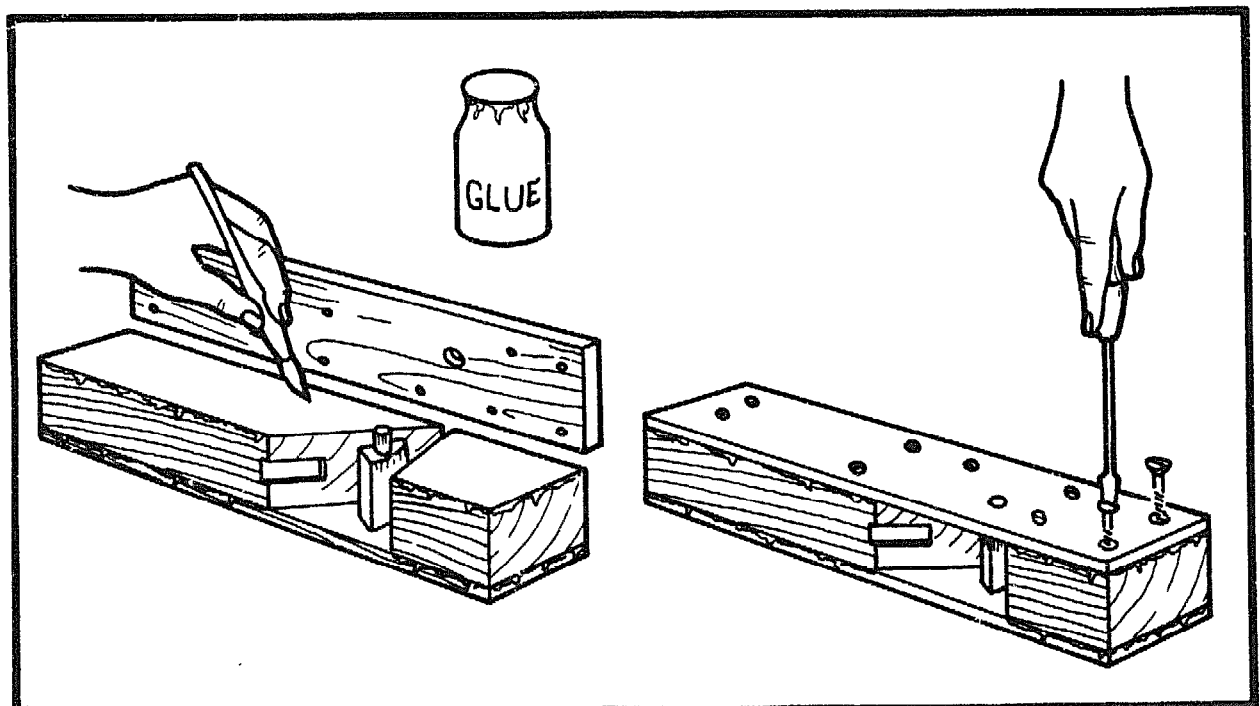

Glue and screw the pieces tightly together.

## Jack plane, handled version

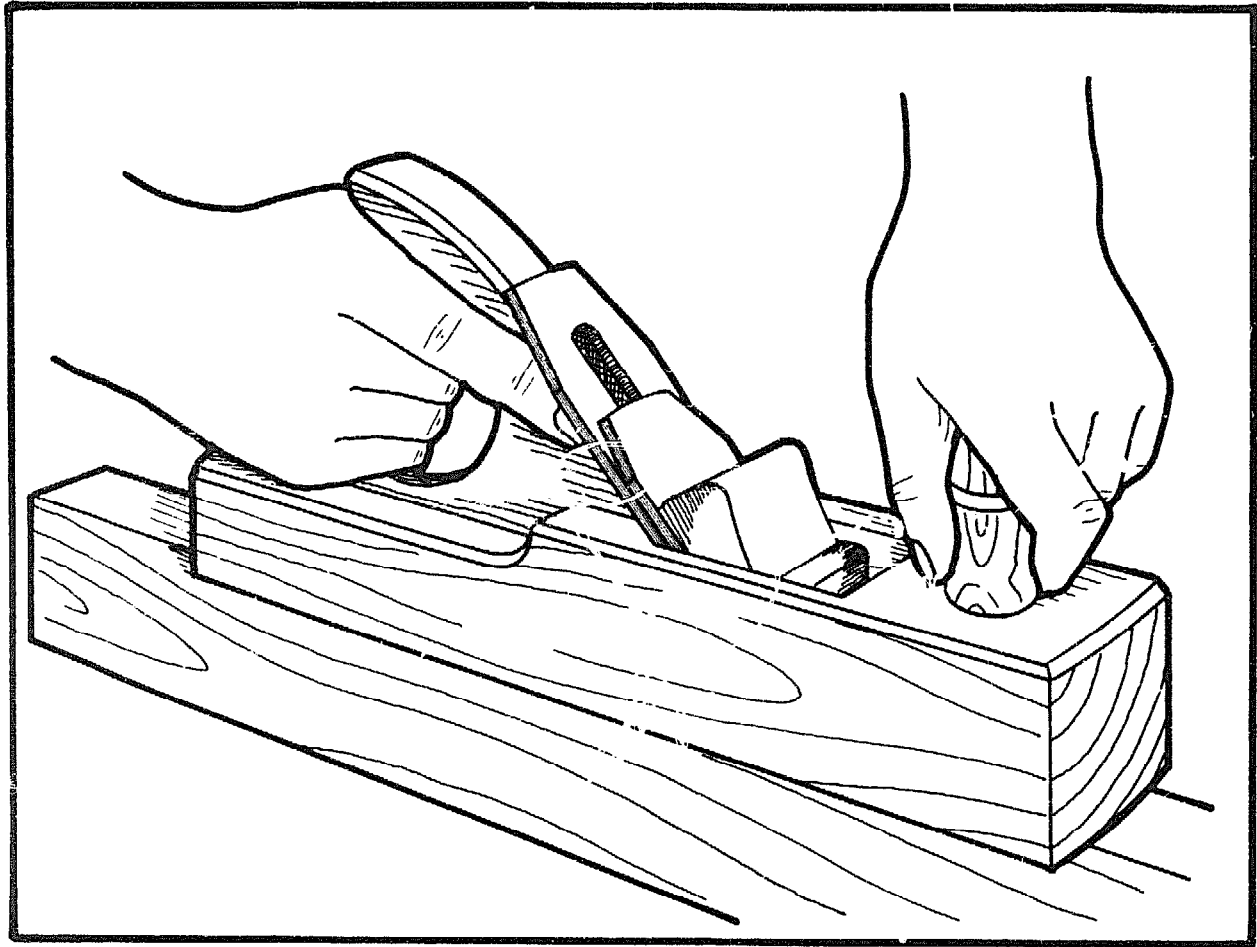

On the following pages are instructions for adding a handle and a knob to the stock previously described. Apart from making the plane more comfortable to hold and easier to control, these modifications can make the tool into a very pleasing object.

Both the stock and the handle need to be shaped and smoothed very carefully. A sharp chisel or knife, a rasp and sandpaper will be needed to do the job well.

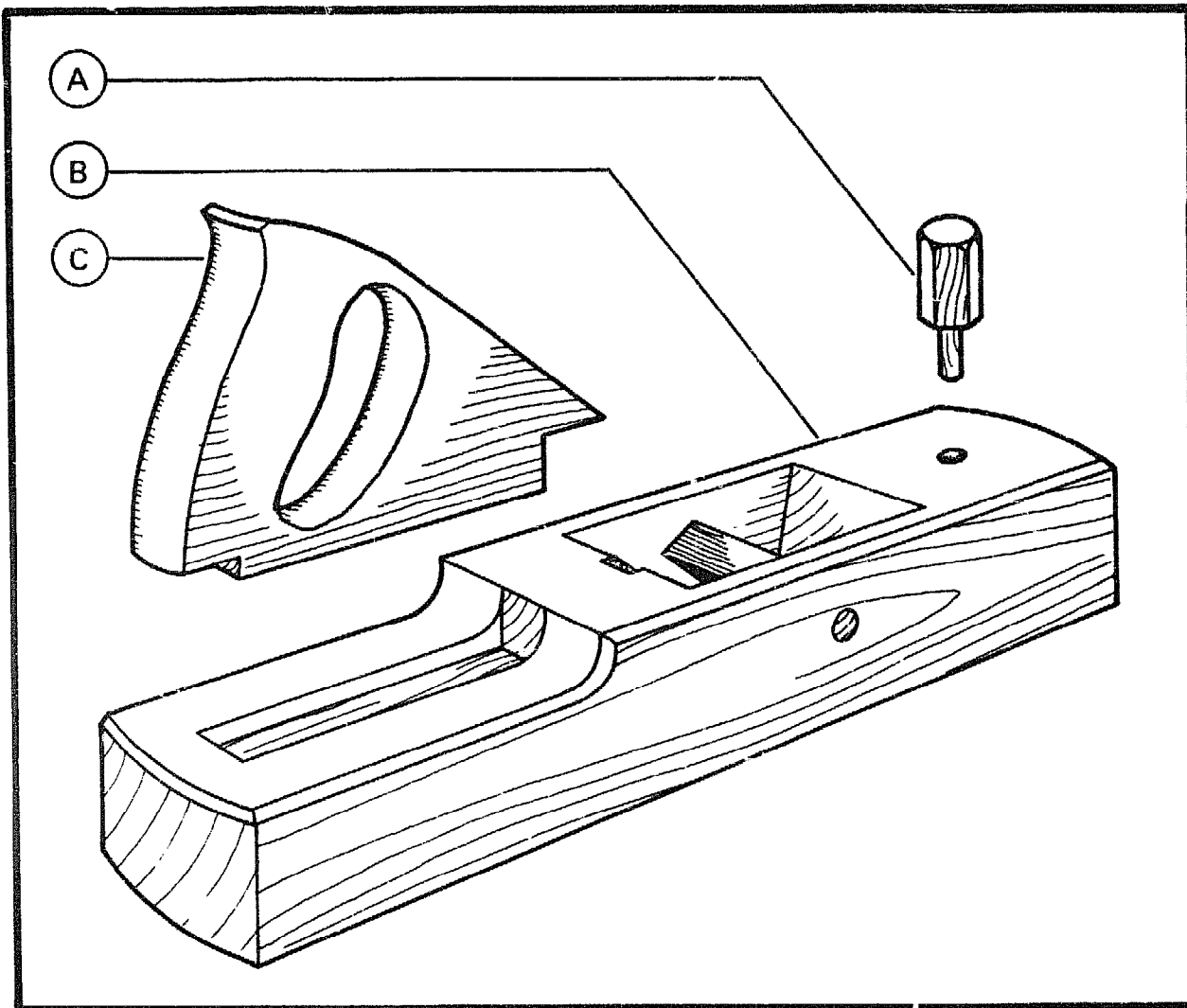

**Part**

- A** *The knob* can be turned on a lathe if one is available, or shaped by hand. It must be securely jointed to the stock.
- B** *The stock* is made by following the instructions beginning on page 10.
- C** *The handle*. This is cut and shaped by hand, and glued into a mortise cut out of the stock.

**CUTTING AND PARTS LIST**

Part	Name	Quantity, Material and Dimensions (mm)
<b>A</b>	Knob	1 pc. Timber 80 × 30 × 30
<b>B</b>	Stock	See pages 7-22 for details
<b>C</b>	Handle	1 pc. Timber 180 × 100 × 25

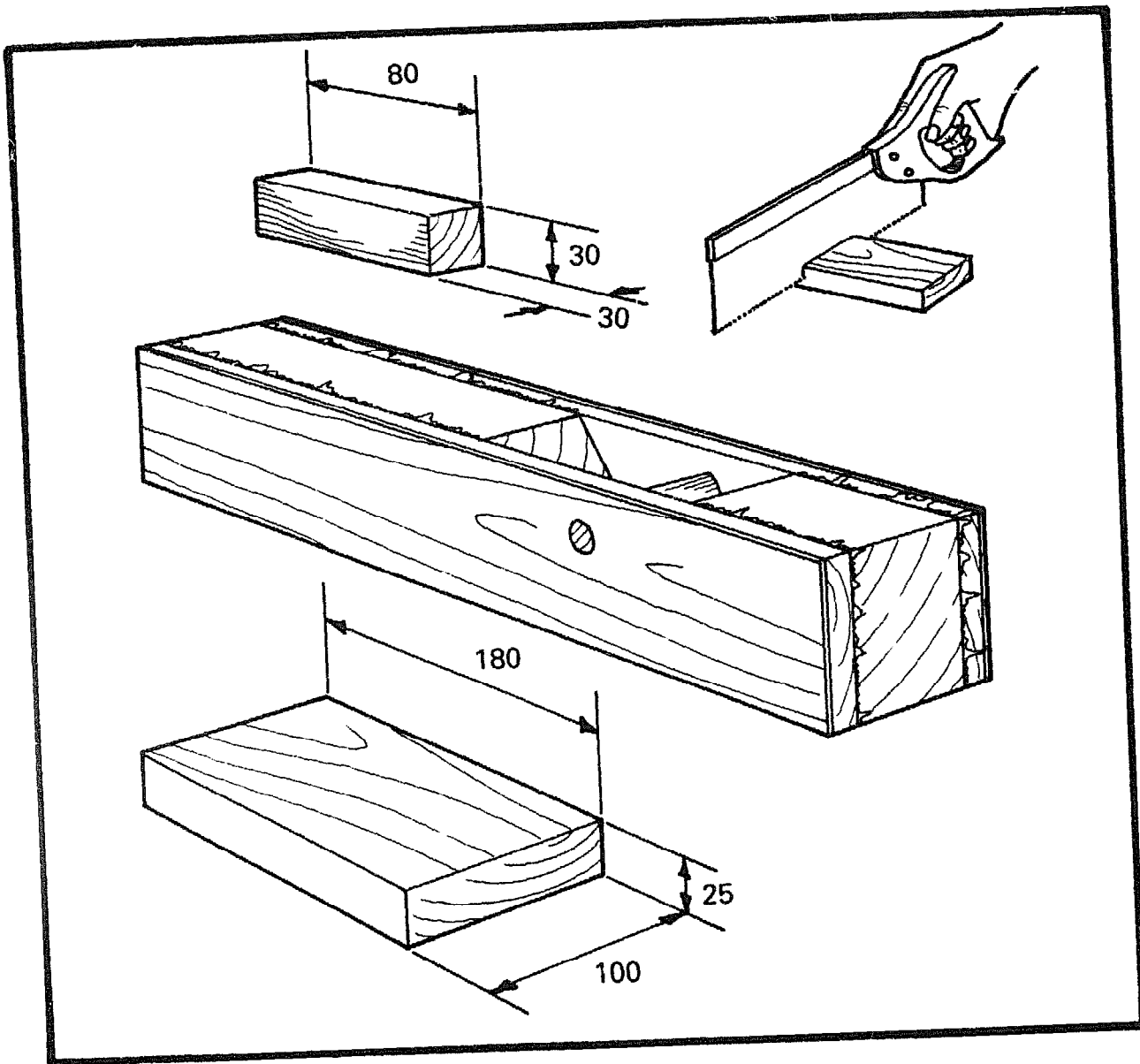
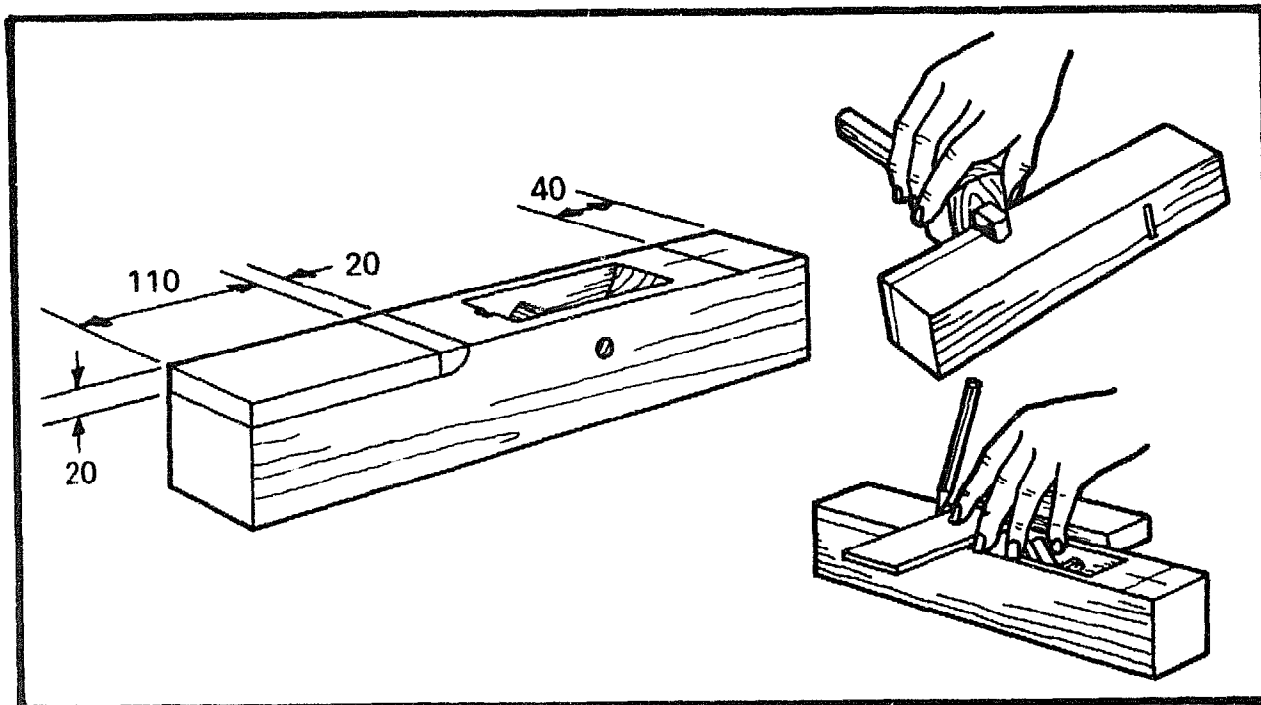

Diagram of cutting list.

## SHAPING THE STOCK



Take the stock and mark the hole for the knob, 40mm from the front, in the centre.

At the back of the stock gauge a line on three sides 20mm from the top. Square two lines across the top, the first one, 110mm from the back end, and the second 20mm from the first. Mark a radius on both sides with a coin.

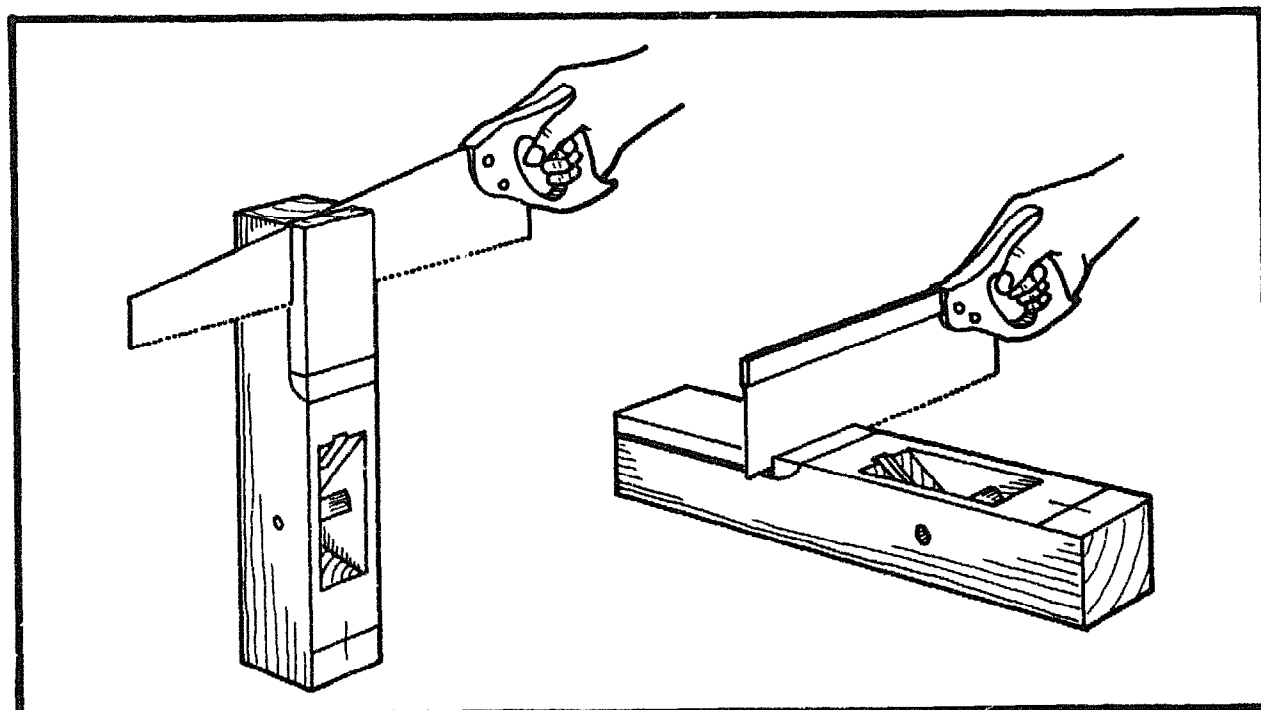

Saw out the waste square to the first line on the top of the stock.

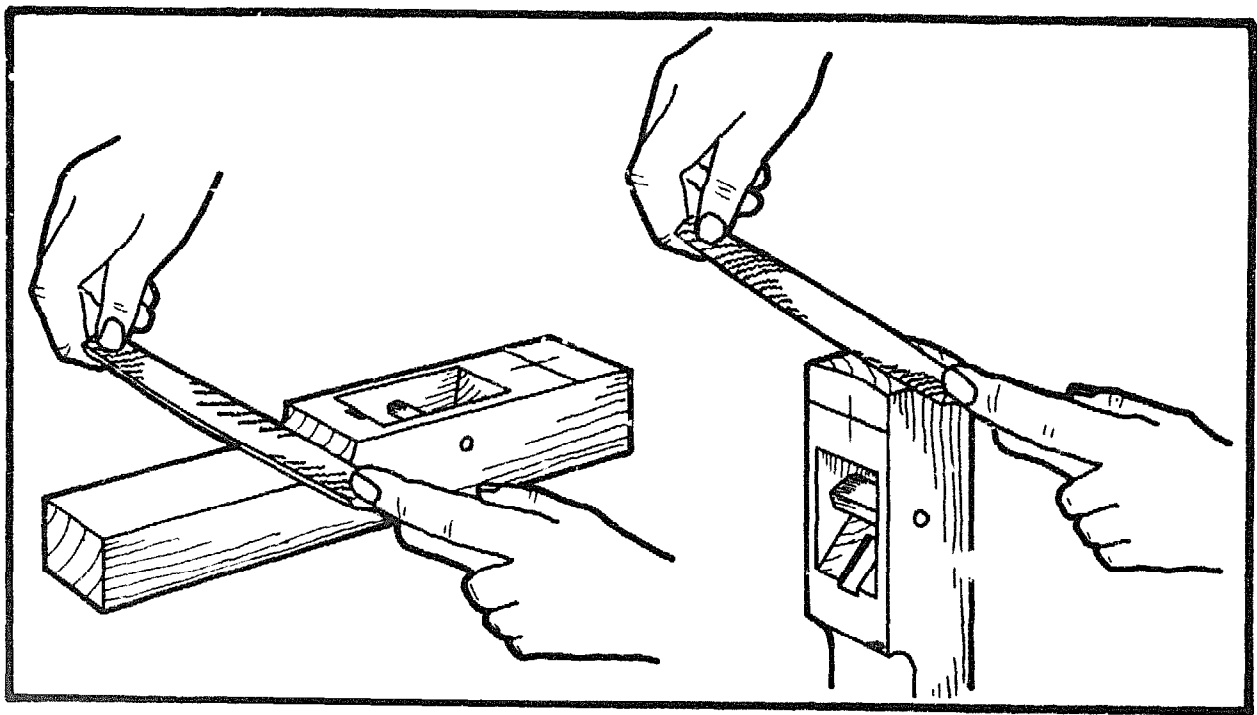

Shape the step of the stock with a chisel and a half round file or rasp, finish off with sandpaper.

Round off both ends either with a plane or a rasp and smooth the end grain with sandpaper.

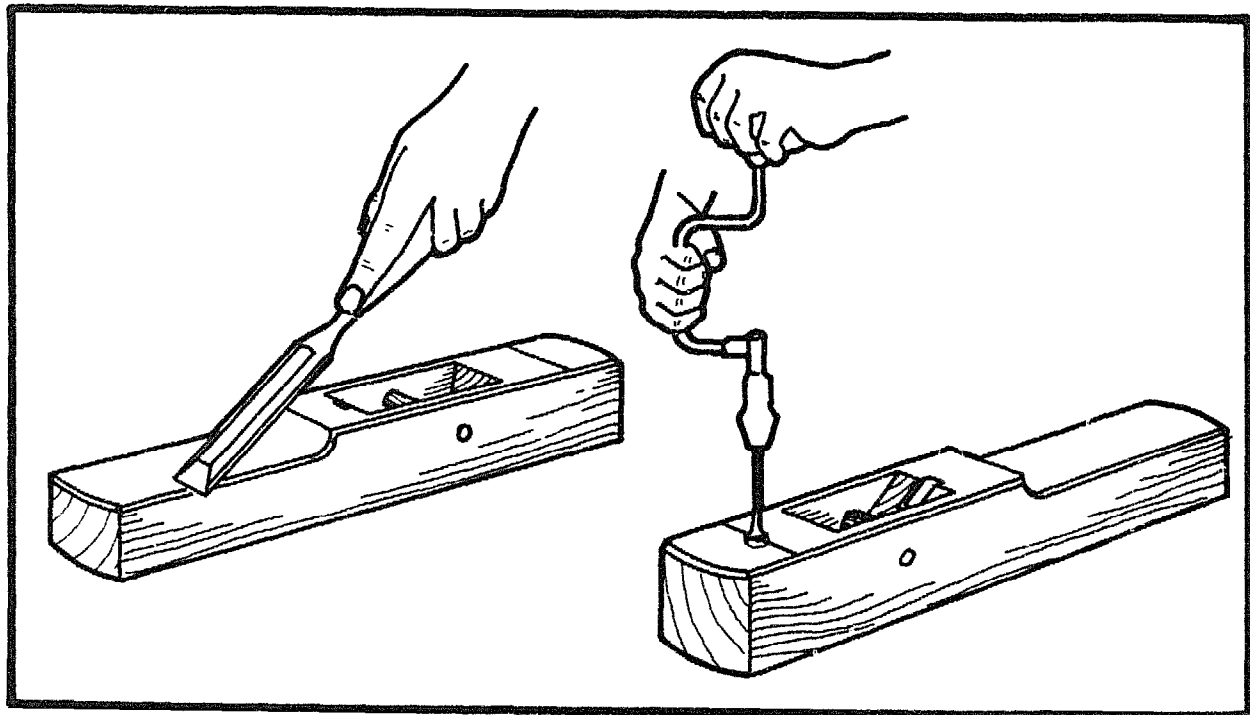

Use a chisel and a plane to cut a small chamfer all round the top edge of the stock.

With a carpenter's brace, drill a 12mm hole to a depth of 35mm in the front of the stock.



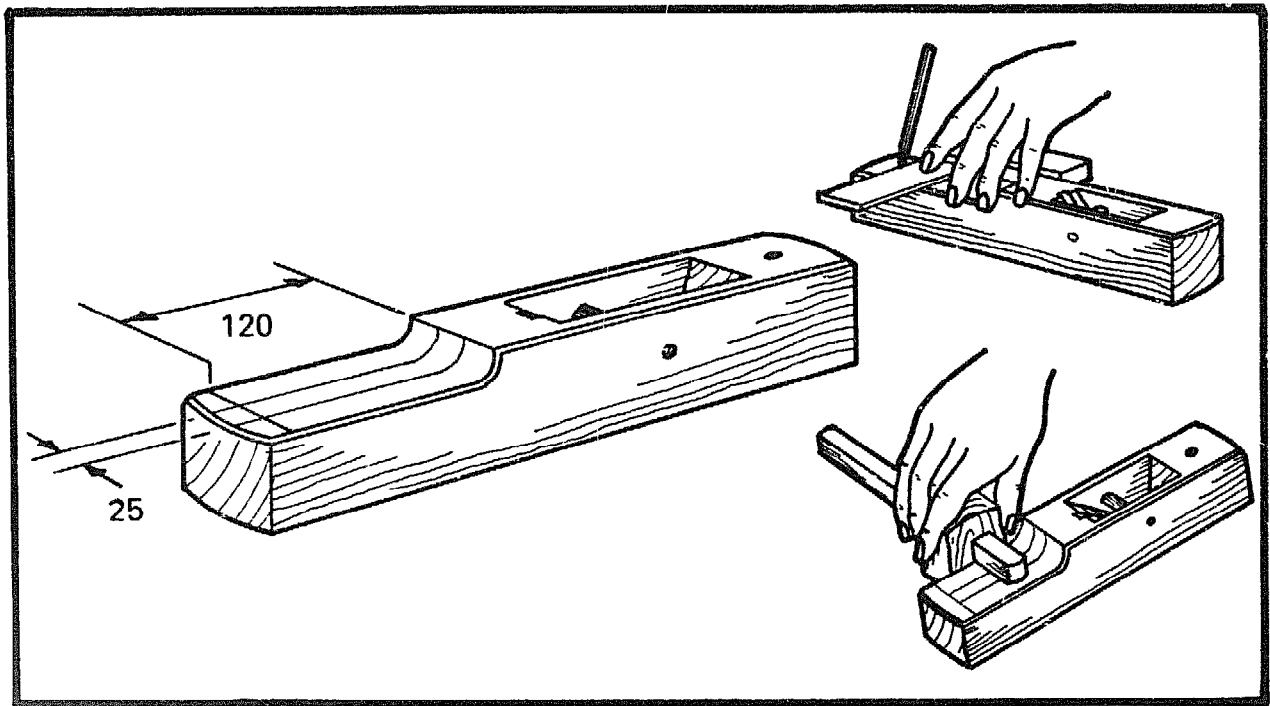

With a mortise gauge, mark the mortise for the handle in the centre of the stock. It should be 25mm wide and 120mm long.

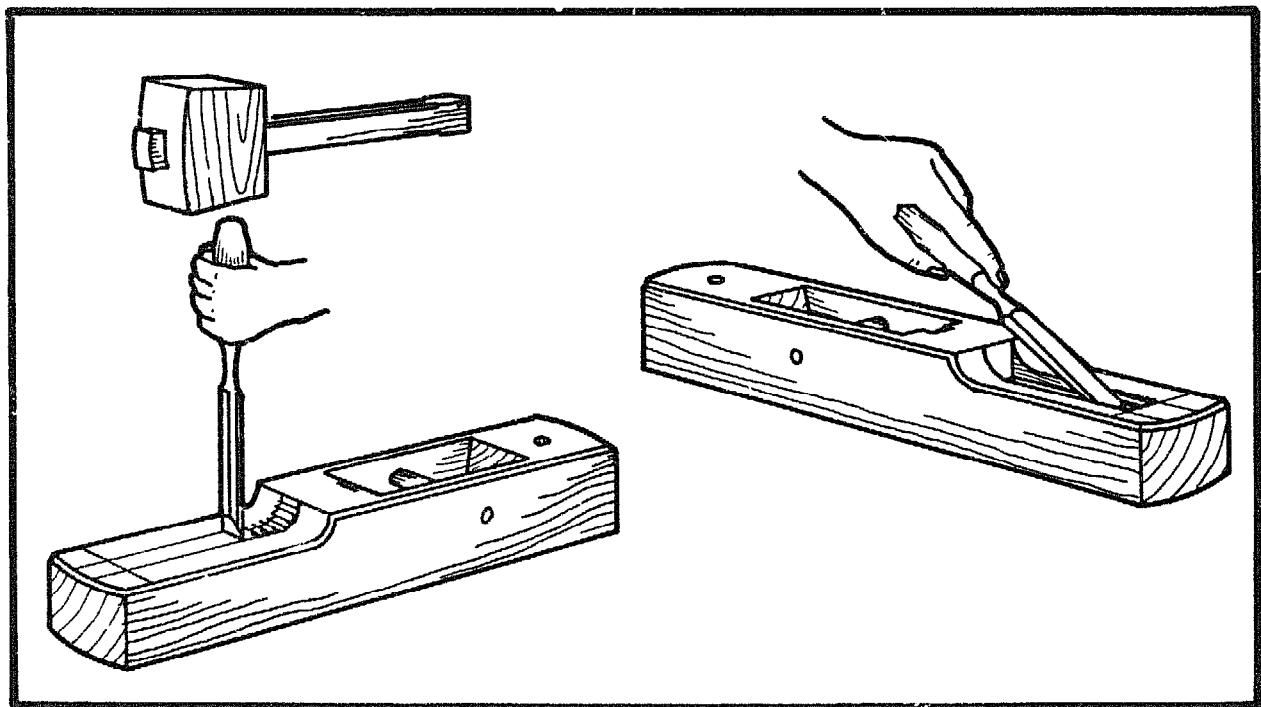

Chisel out the mortise to a depth of 6mm. Take care to keep the sides straight.

HANDLE TEMPLATE  
FULL SIZE

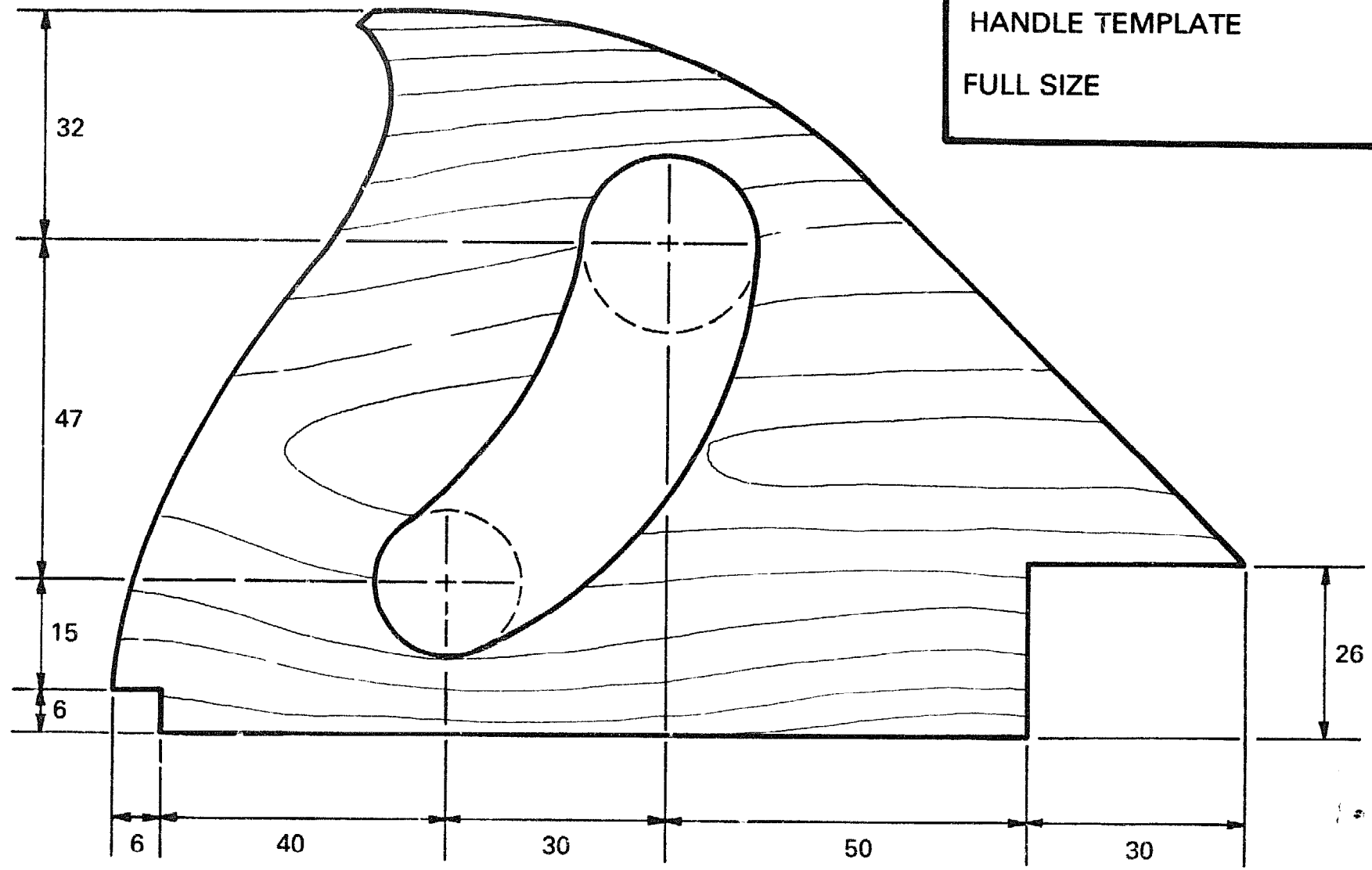

## MAKING THE HANDLE

Trace the template on the opposite page and use this to mark the shape of the handle and the position of the holes.

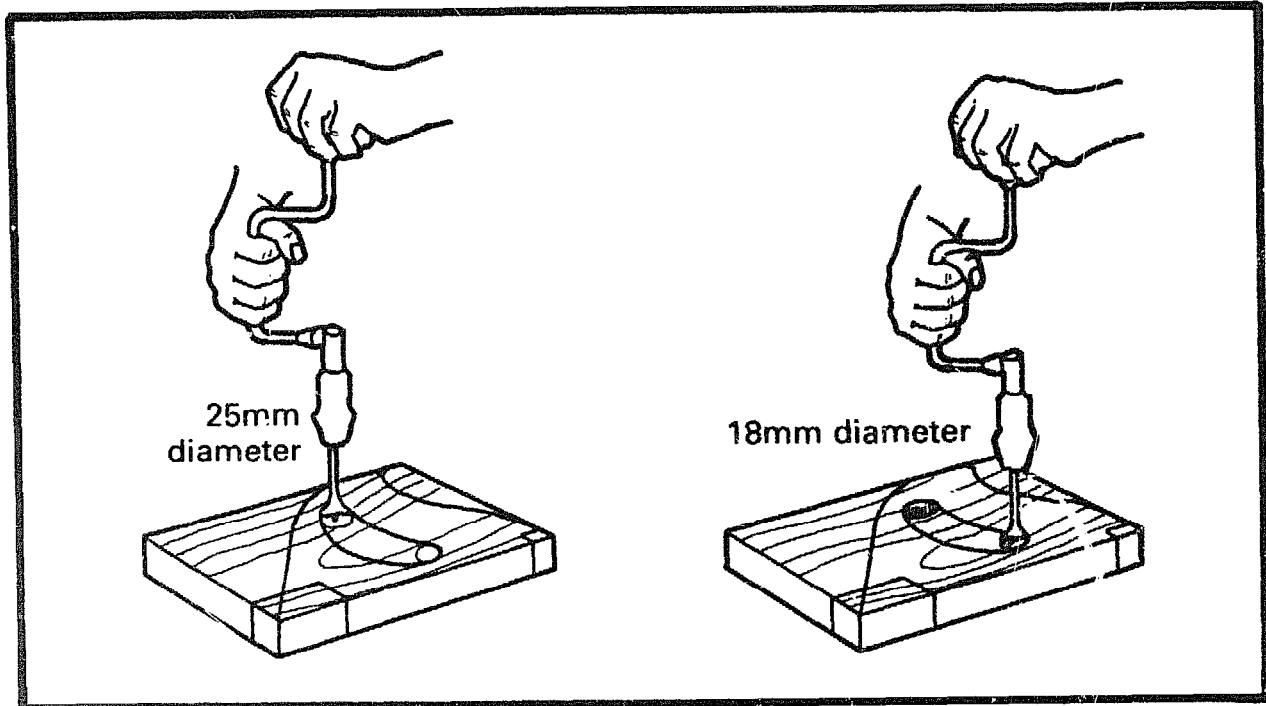

Use a 25mm bit to drill the hole at the top of the handle, and a 18mm bit for the hole at the bottom.

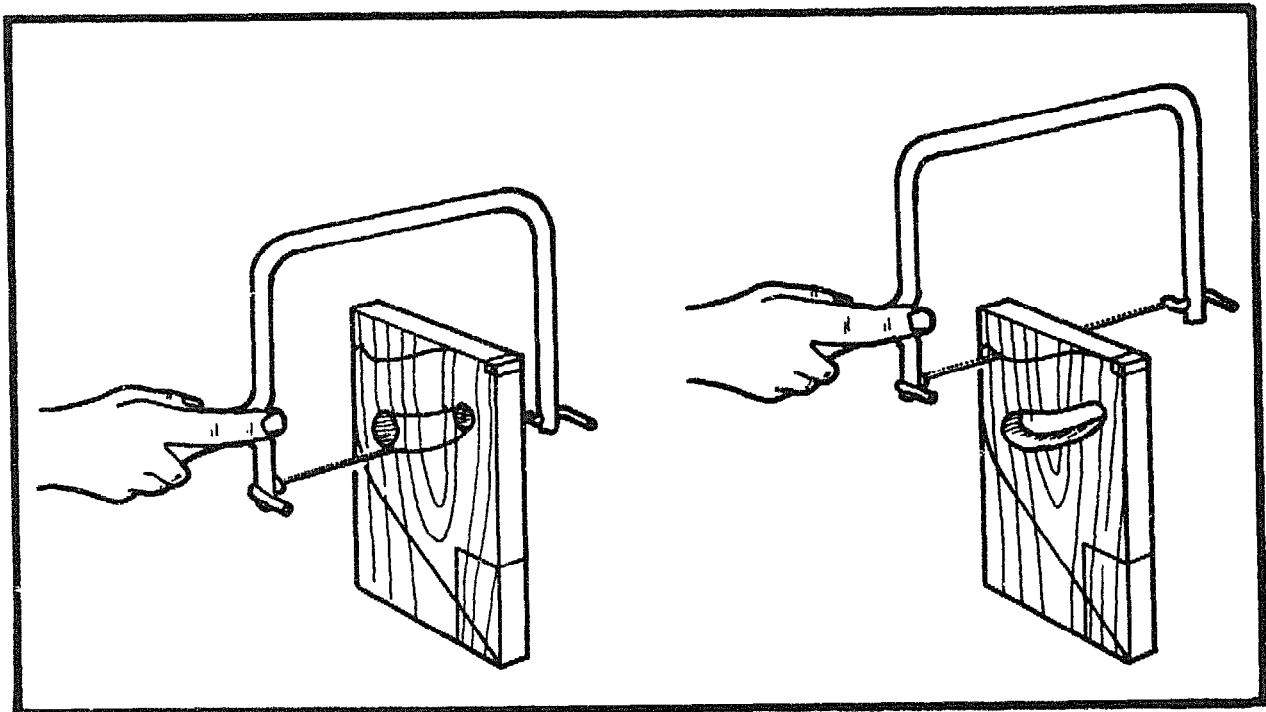

Use a bow saw or a coping saw to cut out the curved parts of the handle.

To saw out the hole, remove the saw blade from the frame, thread it through one of the holes in the handle, and fasten the blade to the frame again. The internal shape can now be cut.

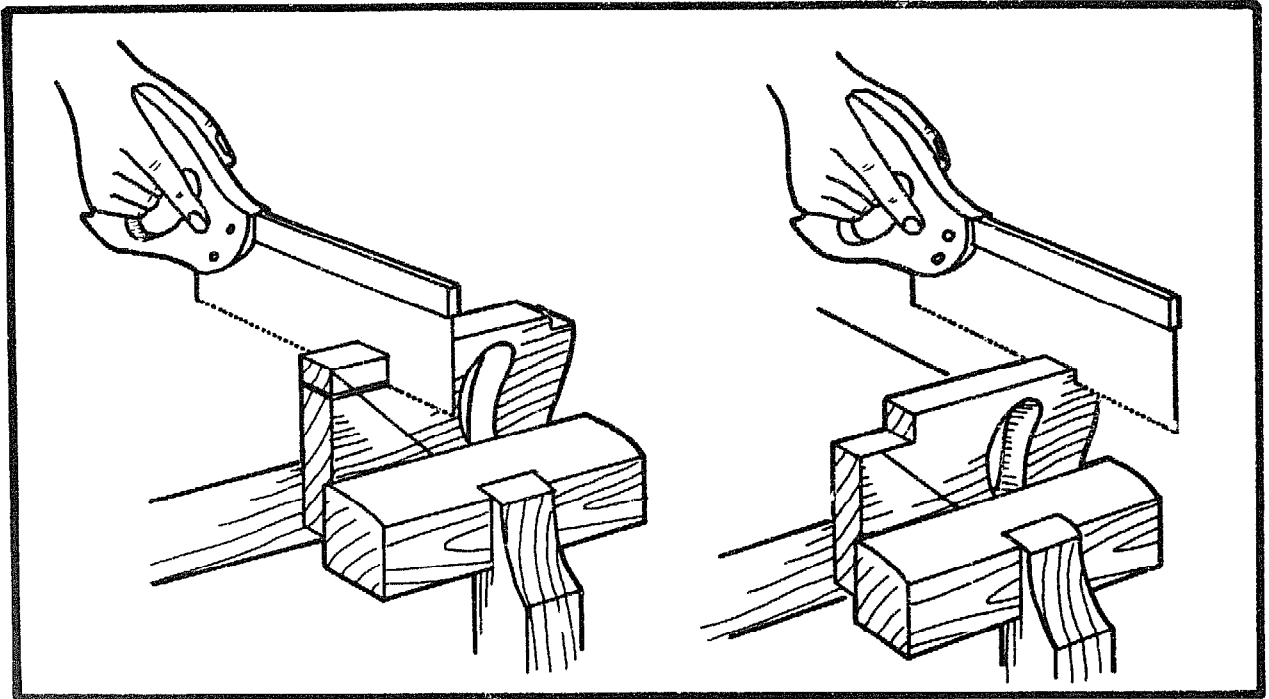

Use a tenon saw to cut away the shoulders on each end of the tenon on the handle.

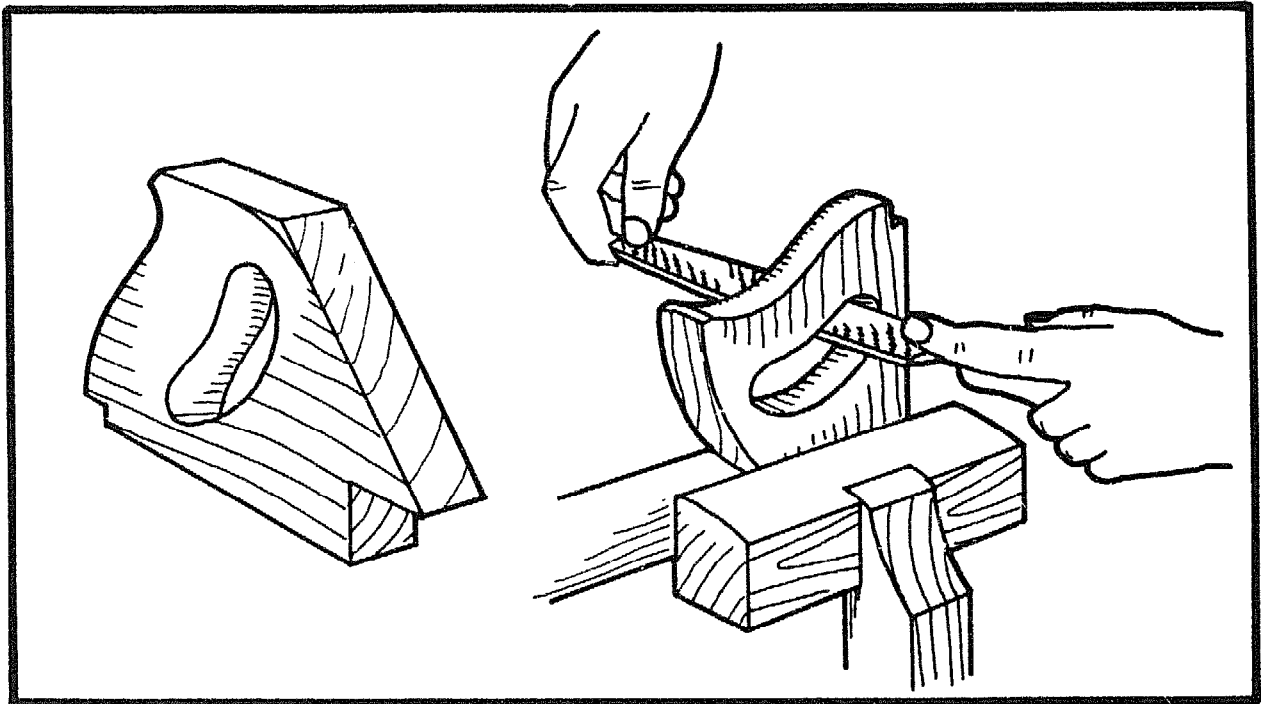

Cut the 45° slope on the front of the handle. Use chisels and rasps to round the 'grip' of the handle, and finish with sandpaper.

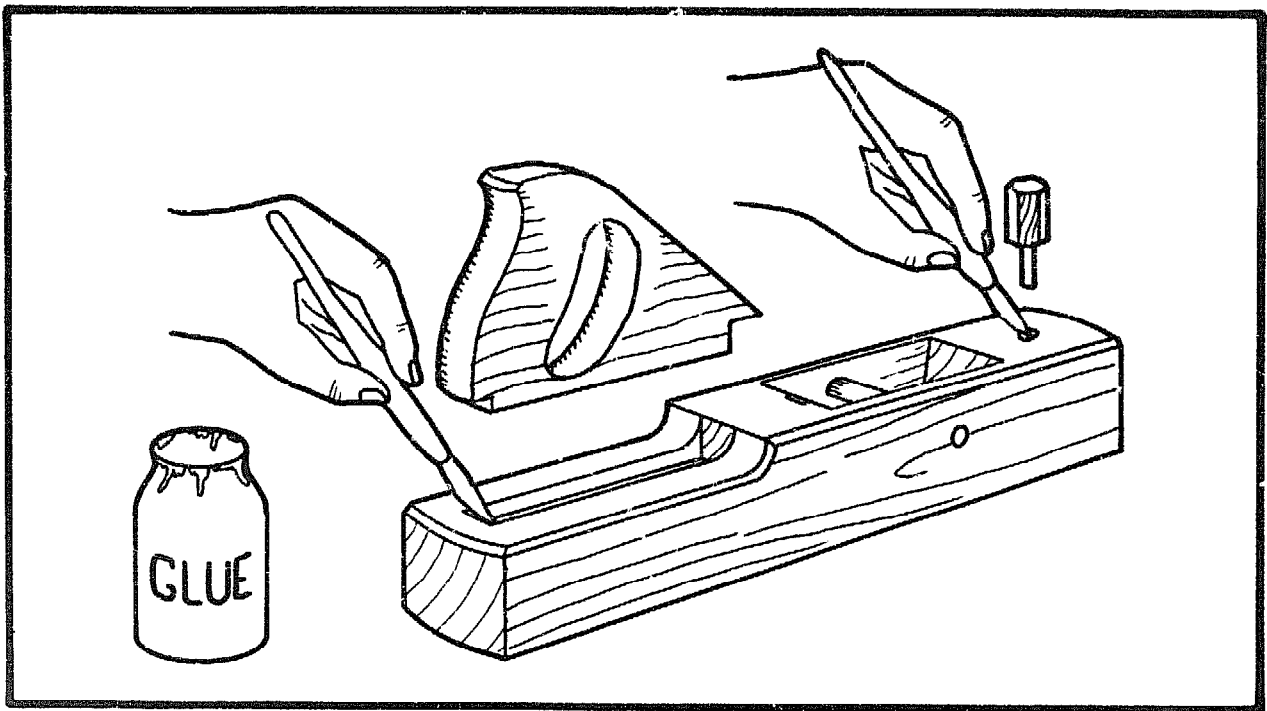

Make sure both the handle and the knob fit well into their mortises. Glue them in and clamp if necessary.

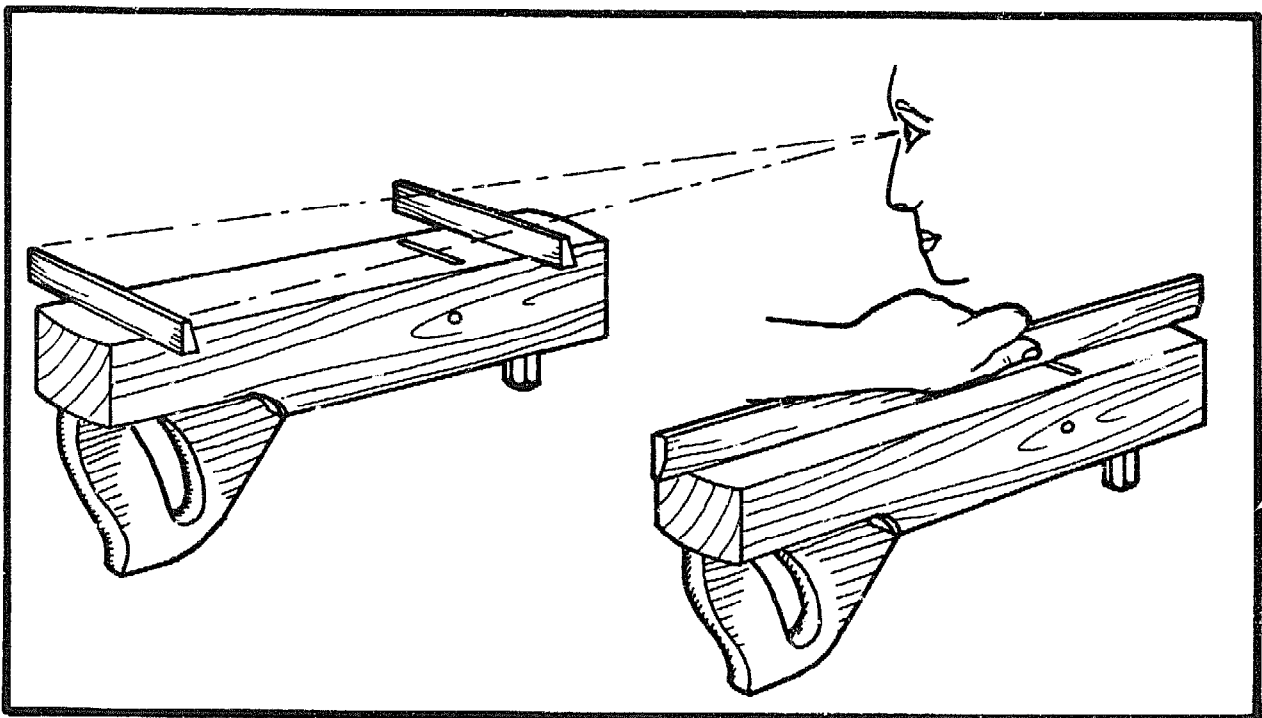

Plane the sole of the plane very carefully so that it is straight and free from winding.

The mouth opening should be no wider than 5mm.

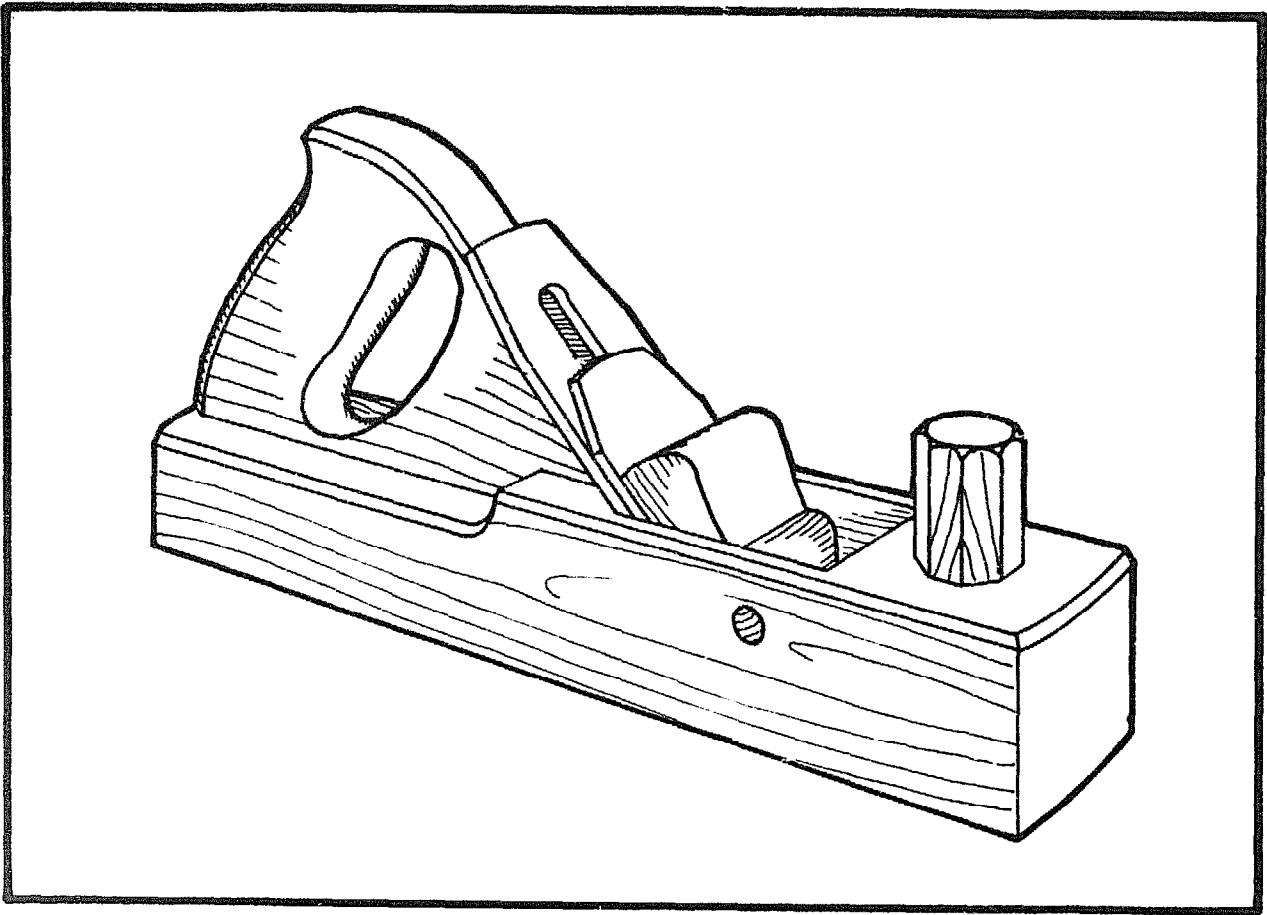

Finished jack plane.

# Rebate plane

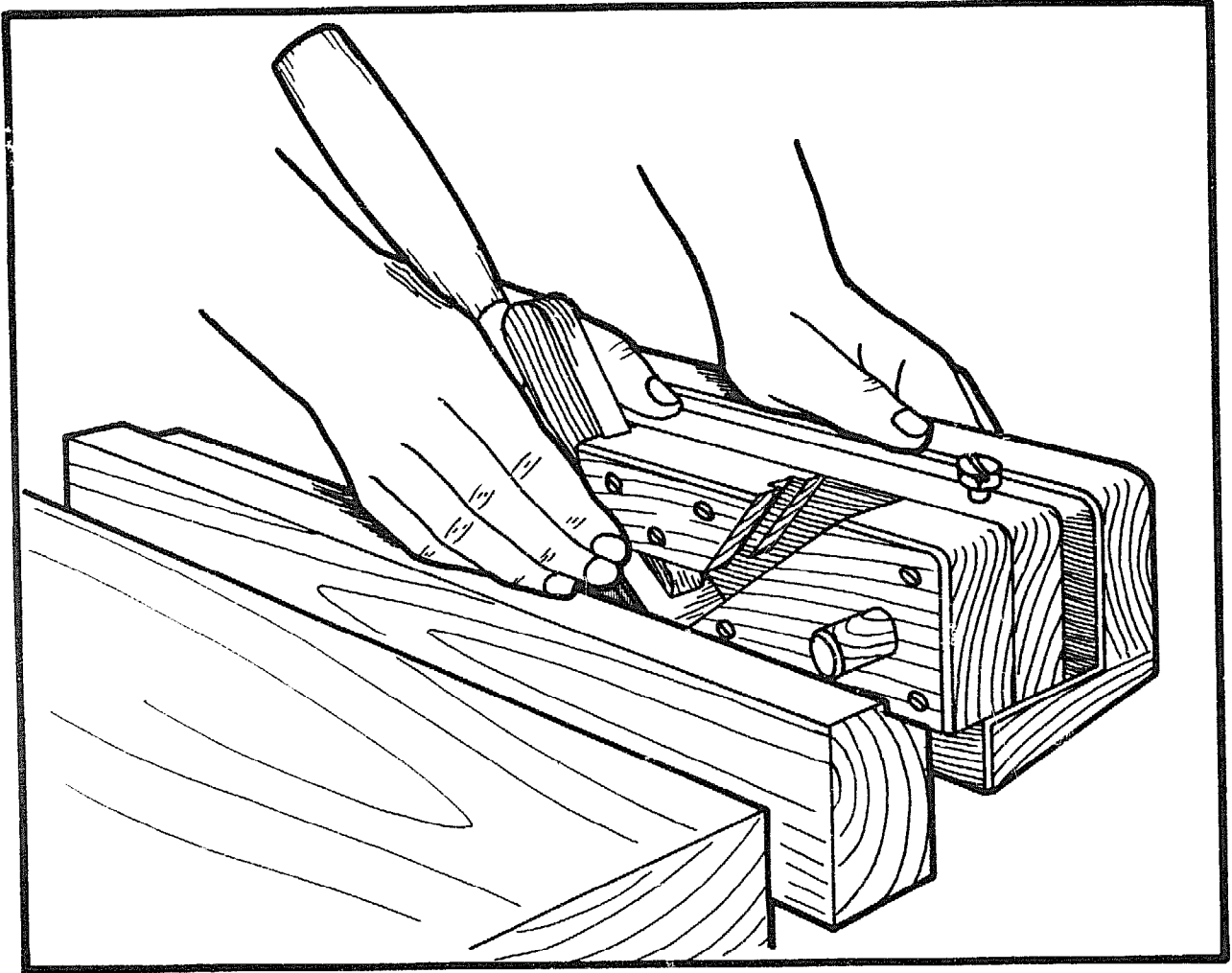

A rebate is a rectangular recess or step along the edge of a piece of wood. Cutting rebates is an essential part of all carpentry and joinery work; they are to be found in doors, door frames, windows and furniture. Rebates can be worked using saws or chisels, but this takes time and skill. A rebate plane is designed to do the job accurately and efficiently.

The tool described here uses a 20 or 25mm chisel as the cutter, which eliminates the problem of making or buying a blade specially for the plane, although one could be made from a piece of carbon steel.

The blade only extends to one side of the plane body, but because it has two blade beds the plane can be used in either direction. The chisel or cutter is held in place by a wedge and is adjusted in the same way as the wooden jack plane.

Rebate planes can be used without a fence, but for accurate and repetitive work an adjustable fence is very useful. The construction of two alternative versions are described on pages 46-56.

Do not begin to make this tool until you have obtained a suitable chisel or cutter, with a blade at least 100mm long.

## LIST OF PARTS

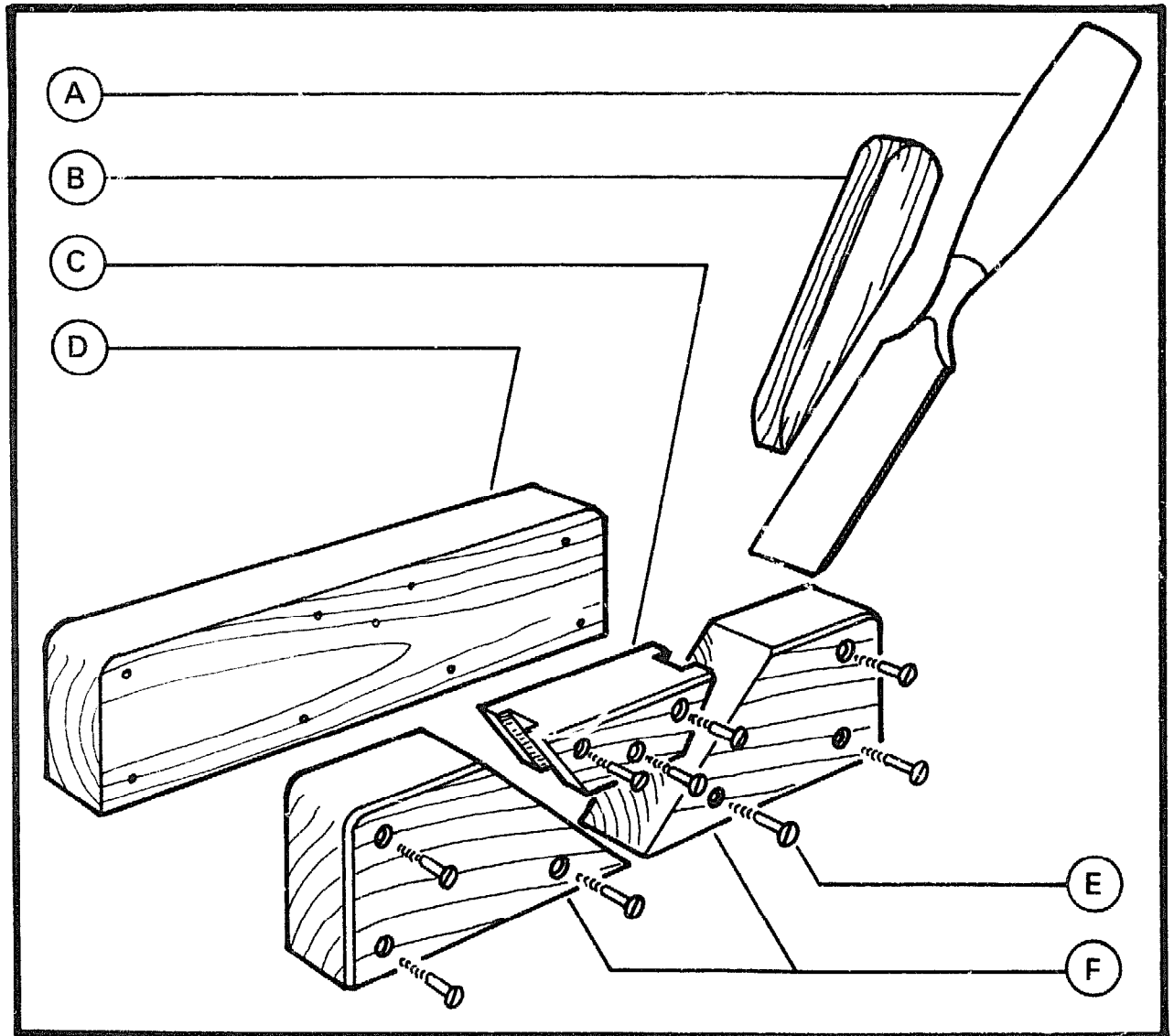

- A** *Chisel or cutter.* This must be between 20 and 25mm wide and at least 100mm long.
- B** *The wedge* fits into a groove in the bearing block, and holds the blade firmly to the bed of the plane.
- C** *The bearing block* is screwed to the side piece of the plane, and holds the wedge in place.
- D** *The side piece* is securely fastened to the three pieces of the stock.
- E** *Screws.* Nine wood screws are used to fix the body of the plane together.
- F** *The blade beds* as well as the bearing block are cut from one piece of timber. They must be exactly the same thickness as the width of the blade.



# CUTTING AND PARTS LIST

Part	Name	Quantity, Material and Dimensions (mm)
A	Cutter	1 pc. Chisel, or tool steel 20-25 × 100
B	Wedge	1 pc. Timber 120 × 20 × 12
C & F	Stock	1 pc. Timber 250 × 65 × 'Dim A'
D	Side piece	1 pc. Timber 250 × 65 × 25
E	Screws	9 pcs. 1½" (37mm) No.8 Wood screws

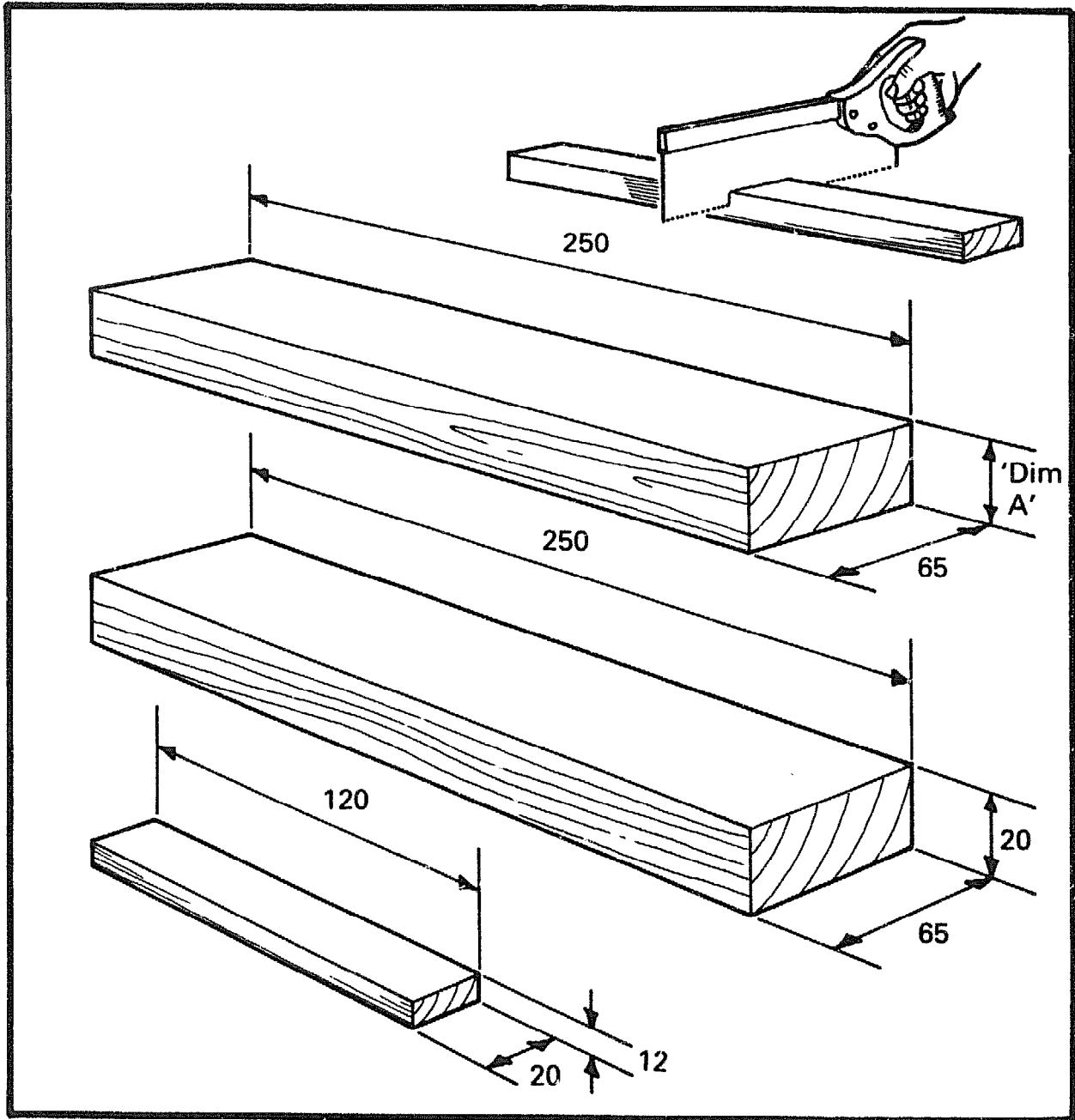

Diagram of cutting list.

'Dim A' refers to the width of the blade.