

AT MICROFICHE
REFERENCE
LIBRARY

A project of Volunteers in Asia

Multi-Purpose Power Unit with Horizontal Water
Turbine: Basic Information

by A.M. Nakarmi and A. Bachmann

Published by:

Sahayogi Press
Tripureshwar
Kathmandu
NEPAL

Available from:

UNICEF
P.O. Box 1187
Kathmandu
NEPAL

Reproduced by permission.

Reproduction of this microfiche document in any form is subject to the same restrictions as those of the original document.

NEW EDITION

M P P U

MULTI-PURPOSE POWER-UNIT
WITH HORIZONTAL WATER TURBINE

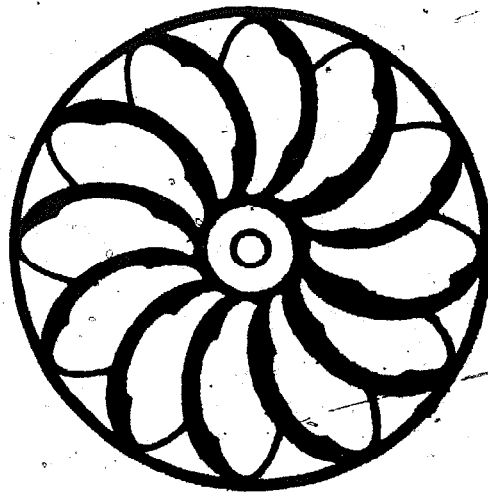

BASIC INFORMATION

A.-M. NAKARMI
A. BACHMANN

OVER



MPPU's

PRODUCED IN LESS
THAN TWO YEARS.

M P P U
MULTI-PURPOSE POWER-UNIT
WITH HORIZONTAL WATER TURBINE

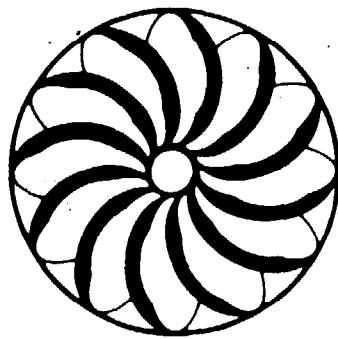

VOLUME : I

BASIC INFORMATION

A.-M. NAKARMI
A. BACHMANN

SAHAYOGI PRESS
KATHMANDU

Published by:
Sāhayogi Press
Tripureshwar
Kathmandu

First Edition, April 1982

Second Edition, March 1983

Copyright is reserved by the authors, but permission is hereby granted for the reproduction of any part, text or drawing, for non-profit publication; however the whole booklet, or any major portion, should not be reproduced without permission. Anyone making use of material presented herein is requested to acknowledge the source and submit to the authors a copy of the excerpt.

Printed in Nepal
at Sahayogi Press.

CONTENTS

Acknowledgement	7
Foreword	9
Introduction	11
Development of Traditional Water Mills	12
The Multi-Purpose Power-Unit	13
Performance	14
Installation	14
Operation	15
Technical Data	15
Costs	16
Conclusion	16
MPPU Concept	17
Single Part Application	18
Sketch of Measurements	19
Site Specifications I Front View	20
Site Specifications II Top View	21
Site Specifications III Different Samples	22
Mill House - Standard Size Left Hand	23
Mill House - Standard Size Right Hand	24
Photographs	25

Horse Power Requirements and r.p.m. _____	44
Survey Report _____	45
Quotation _____	46
Quotation for Appliances _____	47
Measuring the Head _____	48
Measuring the Flow _____	49
Conversion Tables _____	50
Comparison with Traditional Mills _____	51
Glossary _____	53
Notes _____	55
References _____	56
Further Readings _____	57

ACKNOWLEDGEMENT

The Multi-Purpose Power-Unit has become a viable alternative to existing methods, both modern and traditional, of small-scale hydro power utilization.

We are grateful to many people involved, especially to:

- the rural population for their interest,
- the Agricultural Development Bank, Nepal, for their assistance with dissemination of this technology,
- UNICEF, for their considerable support,
- the Royal Government of Bhutan,
- Late Rev. B.R. Saubolle (Nepal), Corneille Jest (France) Fritz Maurer (Bhutan), Jürgen Steiger (W.-Germany),
- and last but not least to the manufacturers for their active role in production and installation.

These combined efforts have enabled many people to become more self reliant. This has lead to the production of the gratifying number of fifty units up to the beginning of 1983, although production started only in the summer of 1981.

Thanks also to Gerry Neville for his valuable assistance for the improvements of this second edition.

Akkal Man Nakarmi and Andreas Bachmann

FOREWORD

The welcome given to the first edition of "Multi-Purpose Power Unit" (MPPU) in Nepal and many other countries has been very heartening.

We have pleasure in offering the public a second edition. The aim of this booklet is to spread this new concept for low-head water power utilization. This publication is for general information, but is not meant to be a construction guide for MPPU's.

In this edition are revisions incorporating ideas gained from practical experience of these units, and we hope to learn even more from experiments under way. It would have been helpful to receive comments from specialists in the field of mini-hydro power development for further improvements of these units. We would welcome any suggestions that might be forwarded.

We are pleased to note that, judging by the demand for these units, the MPPU has gained widespread acceptance.

The authors.

INTRODUCTION

The preparation of food for the family is a task that is almost always undertaken by women and girls in rural Nepal. Although traditional technologies are used to reduce the amount of manual labour involved in processes such as dehulling, and grinding cereal grain, these tasks still demand a considerable amount of time and effort on the part of many women. In order to obtain a small quantity of oil for cooking, women are required to crush mustard seeds in a *kol* (a large and heavy wooden pestle and mortar). In the home, dehulling of rice is carried out using a foot-operated pounder known as a *dhiki*. Cereal grain and pulses are ground between two stones on a hand-turned device called a *jhanto*.

In many hill villages a more efficient technology is available for grinding cereals - a *ghatta*, which is a traditional water mill. These mills are usually owned by a local miller; a large farmer or a community who has the water rights of a channel or a small stream. As payment for his services the miller retains a proportion of the cereals processed. The horizontal grinding stones are driven by water hitting a wooden propeller. It is believed there are more than 30,000 mills still functioning in Nepal. Some run for part of the year, and others continuously, depending on the availability of water and the local demand for their services.

This booklet describes an improved and more efficient mill that has recently been developed for use in Nepal. In view of the various types of equipment that can be driven from the central power unit, it has become known as the multi-purpose power-unit (MPPU). The machine has

been installed in several villages scattered throughout the country, and is being manufactured by local workshops in Kathmandu.

When used at the community level the improved water mill can have a considerable economic and social impact by releasing women from the laborious tasks of dehulling, grinding and expelling oil. More time can be made available for economically productive activities and child care. Additionally, as a source of energy, the improved water mill can help the development of cottage industries within the village. With the production of electricity from the generator unit evening adult education classes may be started in various sites.

DEVELOPMENT OF TRADITIONAL WATER MILLS

As the population increases so there is a greater need for more efficient milling. Farmers will pay more for quicker service. Nowadays there is also interest in other mechanical operation, such as rice hulling, oil expelling, threshing and also in electricity for domestic lighting, etc.

It was often the need for more varied and faster services that stimulated the use of combustion engines and electric motors - both quite costly sources of energy. Because of these additional requirements there have been several attempts to improve traditional water mills. These attempts have been described in different reports. For example, in 1972 a German tried to improve a traditional mill. After he left Nepal, however, the mill was not maintained and no real progress was made.

In recent years a great deal of attention has been given to different water turbines and improved power transformation. There are propeller turbines, cross flow or pelton turbines, etc. Each has its special advantages, and is designed for power transformation mainly above approx. ten horse power.

It is again worthwhile to consider the improvement of traditional water mills and investigate possible new sites with reference to the power transformation required (two to five horse power or more). There are several factors to be gained by improving existing water mills:

- building and water channel
- water rights
- infrastructure (i.e. skills, supply and marketing).

THE MULTI - PURPOSE POWER - UNIT (MPPU)

In the past twenty years over a hundred mills have been installed all over the country, by using combustion engines or electric motors, Animal power, bio-gas and probably wind energy could also be used to provide energy.

Based on this experience a new concept of a MPPU has been developed. A cube with a metallic frame is made housing a "bucket-type turbine", which is fitted below the original milling device. This enables it to run with water power and through the pulley (fixed on the vertical main shaft) mechanical power can be taken off for other machines with a belt system. The machines are made in Nepal, use locally available materials, such as wood, stones, mild steel structures, bearings, etc.

PERFORMANCE

Improved traditional water mills were introduced successfully in the autumn of 1980. These new machines, based on the old system, have a greatly increased performance for:

- grinding: four to eight times more grain can be processed within any given time. (The cover over the stones provides dust-free working and the flour will automatically fall through an outlet into a sack).
- multiple application: any small machine (two to five, ten horse power) can be directly fitted to the power take-off pulley (belt system - no motors) be it a rice huller, an oil expeller, a thresher or micro electricity generator.
- domestic use: a small dynamo (12-V, DC, 400 W) or an additional generator (220-V, AC, ca. 1 to 2 kW) can supply electricity to nearby consumers.

INSTALLATION

The MPPU can easily replace the existing traditional water mills; the size and working performance is designed in the range of the existing, traditional patterns. The unit does not need to vary with different sites, as the cubic design permits the power take-off in three variable directions. The penstock (pipe) -the real variable- will be made according to the site specifications. The installation at existing sites will be simple, as the present channels and building can be used. For fixing the solid, self-supporting MPPU-module cement is not essential.

OPERATION

The MPPU has been successfully introduced in Nepal. To operate them, millers need only a short training course and a few simple tools. Experience has shown that millers soon become effective operators. Pilot installations have been made in the Kathmandu valley and several other places, as well as in neighbouring Bhutan and India. Now efforts are being made for the development of this promising project. The widespread interest evinced shows the need for such devices.

TECHNICAL DATA

The MPPU construction is basically two metal cubes, its frames are made of M.S. angles 50 x 6 mm with welded joints. On the top are grinding stones (500 mm \varnothing), turned by the vertical axis, including a grain feeding device (hopper).

The middle part (upper cube) houses the main pulley for the power take-off, the mechanism for the adjustment of grinding (lever).

The bottom part (lower cube) houses the water turbine and the penstock (pipeline) with a nozzle.

The MPPU is made in different parts to enable porters and small airplanes to transport them to remote areas. The total weight of the unit is approximately 400 kg. For space requirements of the building for MPPU and machines see the drawings and site specifications.

COSTS

To begin with, the MPPU can be purchased on its own; it consists of the grinding device, the turbine, the power take-off device and the small dynamo. As the design is modular and uses standard measurements any additional machine can be installed later. The initial costs, therefore, can be quite reasonable. Price specifications for differing sites may be obtained from the manufacturers. (1 MPPU, incl. dynamo, intake, pipe, costs approx. US \$ 1200/-, January 1983, without additional machines, transportation, installation, training, etc.).

CONCLUSIONS

The MPPU is a new device in modern water power utilization. It uses traditional mills and indigenous technology: it can operate with the same head and quantity of water; and is capable of running several cottage-industry machines. The costs are reasonable (and if compared with other imported machines quite cheap) and they can be installed in a short time (especially if they are replacing existing mills). Most important, the machines are easily understood and operated, so maintenance should not be a major hold-up.

It is not claimed, however, that this is the only solution to the many problems of using water power. There are many other devices which all have their own advantages, and disadvantages - as does the MPPU. But early experience with the grinding operation shows considerable promise.

It is hoped to further improve this machine and we would welcome comments and suggestions.

MPPU CONCEPT

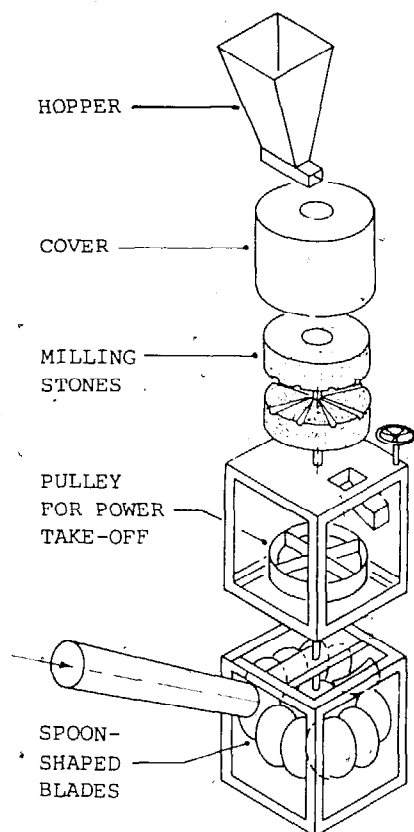

The MPPU is a concept to improve existing traditional mills, as well as to bring new, small scale water power application to the reach of rural people, even to very remote areas.

The installation can be as per traditional set-up; with the same head and same water quantity, it can grind 4 - 8 times more over traditional water mills.

The MPPU can be used as a complete set: turbine, mill and power take-off, and also with its separate pieces;

- turbine only (e.g. small dynamo)
- mill only (to be run by conventional motors; by animal or wind power)

Depending on Head and water quantity the power output can range from 2-5, 10, 15 H.P., and machines can easily be fitted, such as rice huller, oil expeller, dynamo (12V, DC or 220V, AC). The small scale cottage industry can run wood saw, planer, looms, etc.

Some Datas:

Weight: appr. 375 kg
 Height: total 210 cm
 Surface Area: appr. 75 cm²
 of mill only

Power Transformation:

Depending on head and water quantity: 2.5-5 H.P. turbine can produce 10 HP

Transmission:

by belts mainly, electricity for lighting purposes mainly.

Installation Time:

If replacing and existing water mill the installation can be done in a few days.

SMALL AGRO-PROCESSING MACHINE
 -Rice Huller, Oil Expeller, etc.

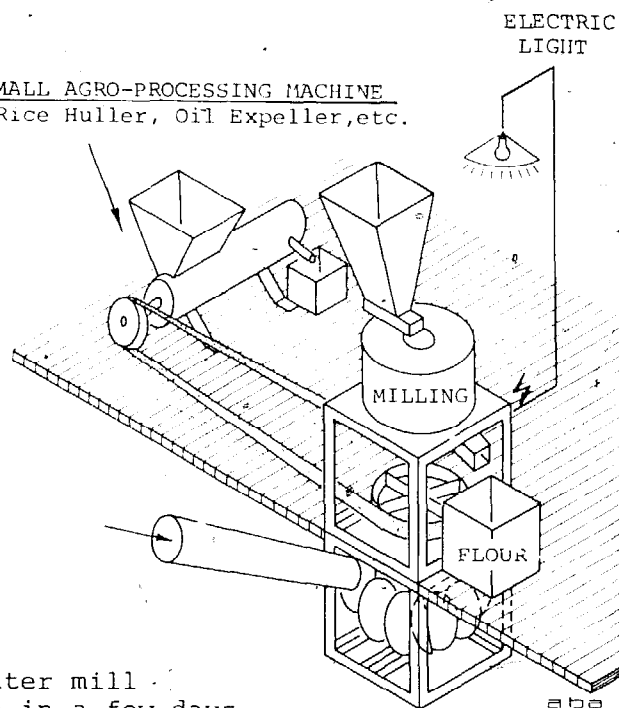

MPPU • SINGLE PART APPLICATIONS

MPPU TURBINE WITH DYNAMO

FOR SMALL ELECTRICITY GENERATION
OR RUNNING OF MACHINES DIRECTLY,
WITHOUT MILL-PART; WHERE
GRINDING IS NOT REQUIRED.
RANGE 5.10 AND FOR MORE H.P.

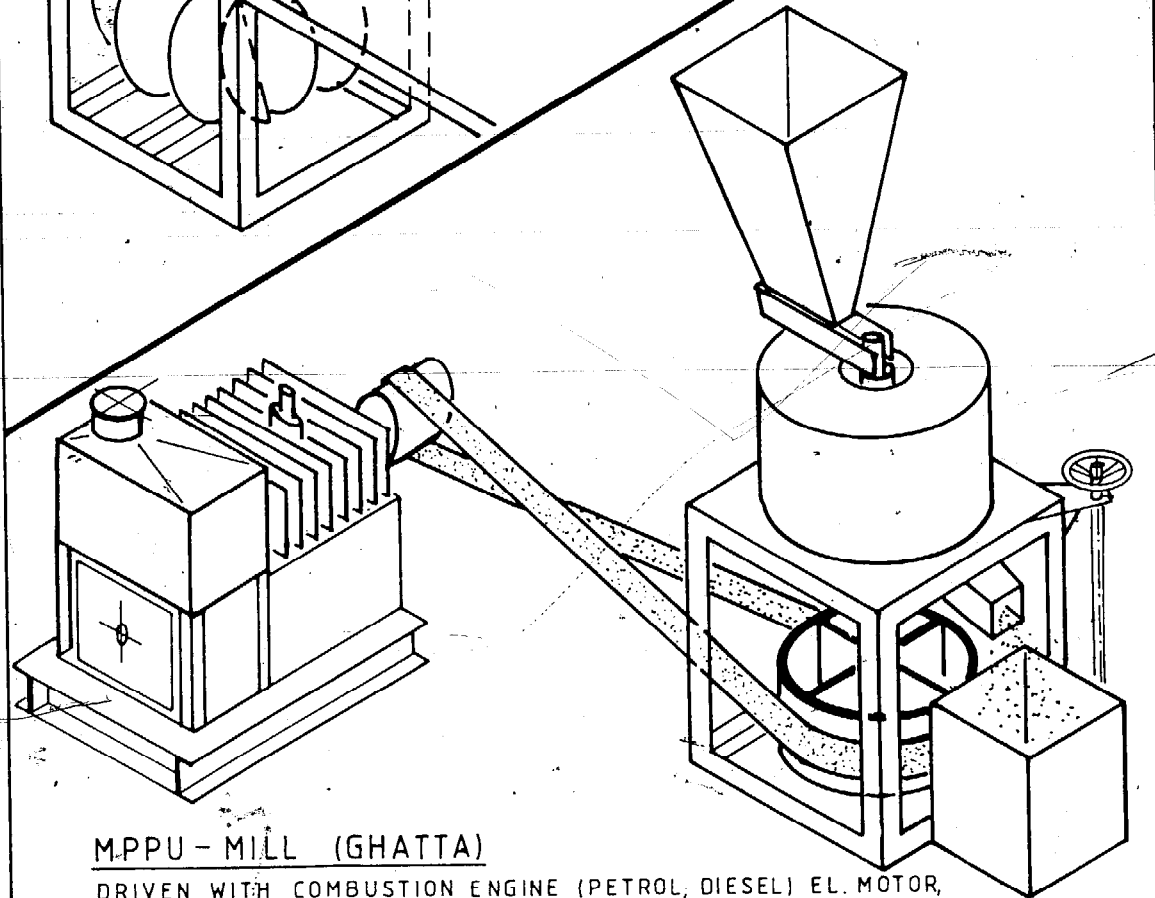
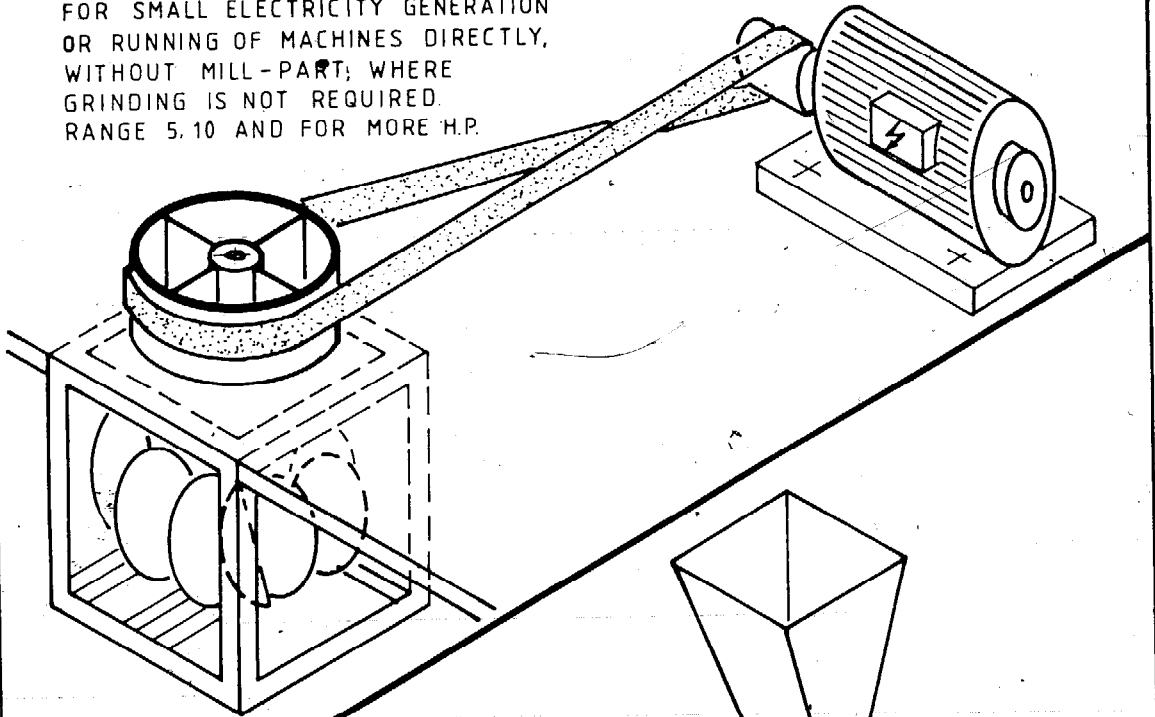

M.P.P.U - MILL (GHATTA)

DRIVEN WITH COMBUSTION ENGINE (PETROL, DIESEL) EL. MOTOR,
BIOGAS MOTOR, ANIMAL- OR WIND POWER.

aba

MPPU • SKETCH OF MEASUREMENTS

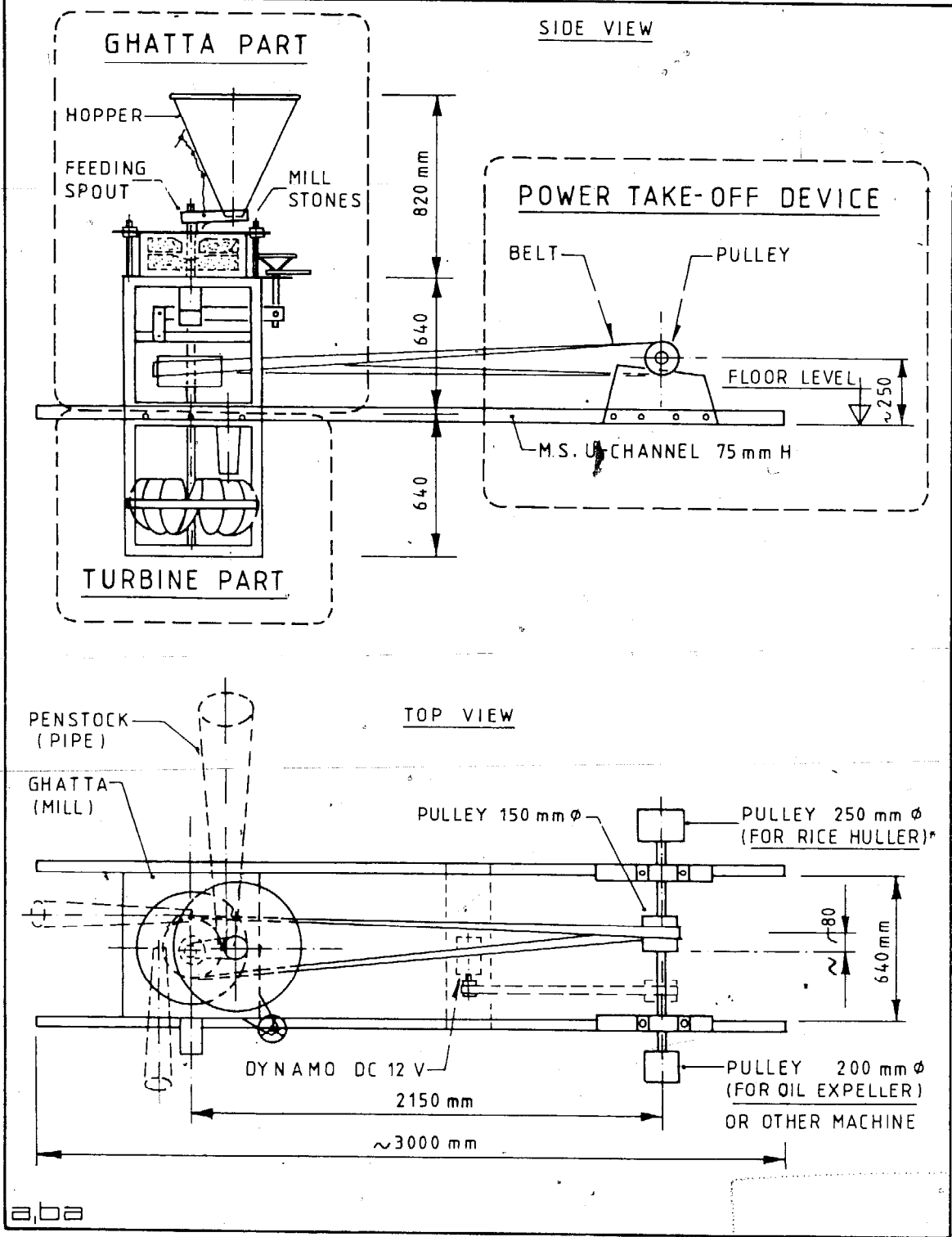

MPPU SITE SPECIFICATIONS

I

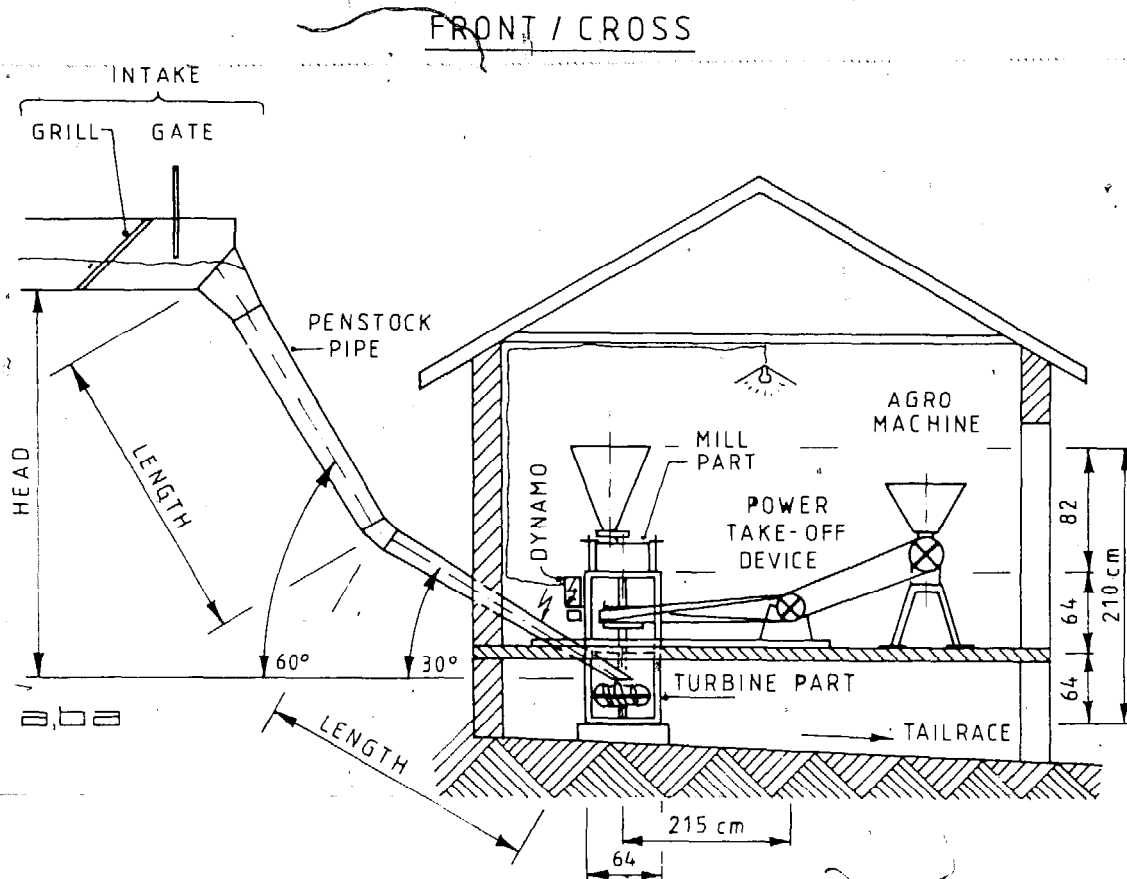

Speed of the MPPU at drive shaft = appr. 250-300 RPM
 (The speed remains \pm 20% constant, with or without load; over-speeding will not occur).

For Horse Power, Speed and Head & Flow see special chart, some samples are given:

Head Meter	80 ltr/sec	100 ltr/sec	120 ltr/sec
	HP	HP	HP
3	2.4	3	3.6
3.5	2.8	3.6	4.3
4	3.2	4.0	4.9
4.5	3.6	4.5	5.4

Note: Minimum water quantity required is 60 ltr/sec.
 Oil expelling needs a minimum of 3 H.P.

MPPU • SITE SPECIFICATIONS

II

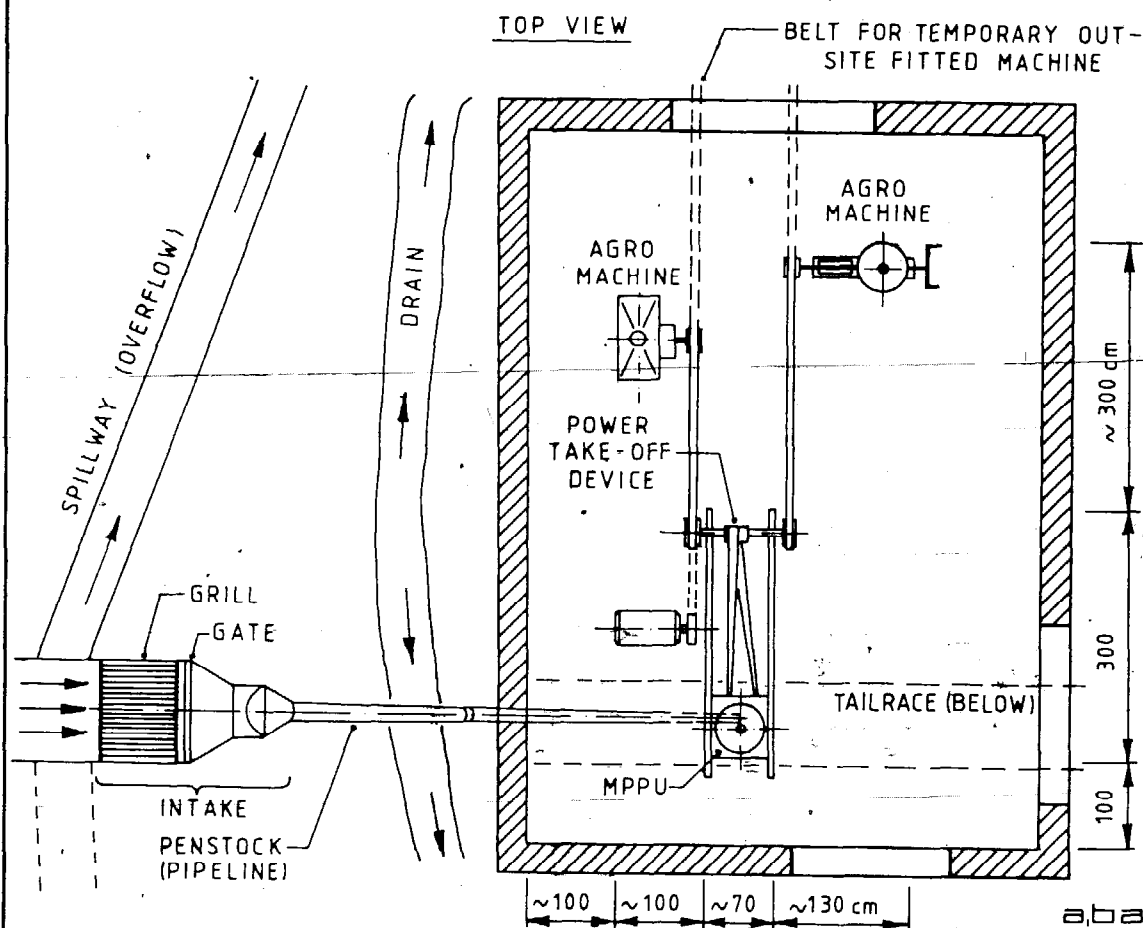

Notes:

A) The MPPU will fit quite easily in traditional, existing structures. Where a new building is made, running one MPPU with several machines, with some space for storage and waiting people, and inside measurement of approx. 8 m length 4 mtr. width (better 6 mtr) and 2.5 mtr in height will be satisfactory. Construction with pillars (instead of fixed walls) will more easily enable access to the MPPU from different sides.

B) A door in front of the power take-off device is recommended, so to enable a temporary outside fixing of an agro processing machine (e.g. thresher).

C) Keep approx. 1 mtr. space free around the MPPU set-up, so to enable easy access. The modular concept of the MPPU enables installation on three sides. The example shown above is a "right hand power take-off". (see also separate pages).

D. Foundation: make sure that the structure is properly protected from the powerful splashing of water from the new turbine (it may wash off traditional or weak structures - use planks, stones, sheet metal, cement, etc. for prolonged protection).

MPPU • SITE SPECIFICATIONS

III

WATER
INLET

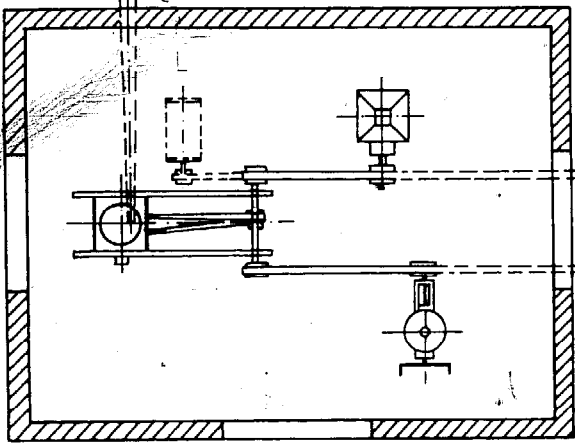

↑ RIGHT HAND POWER TAKE-OFF

MPPU • MODULAR CONCEPT

The different parts are made on standard sizes, and they can be quite easily transported even to very remote parts of the country, if necessary by porters.

The different parts can be assembled in several different ways, so as to meet the actual building and site requirements.

The water inlet can be from three different sides, and the flour exit spout may be turned to the required place.

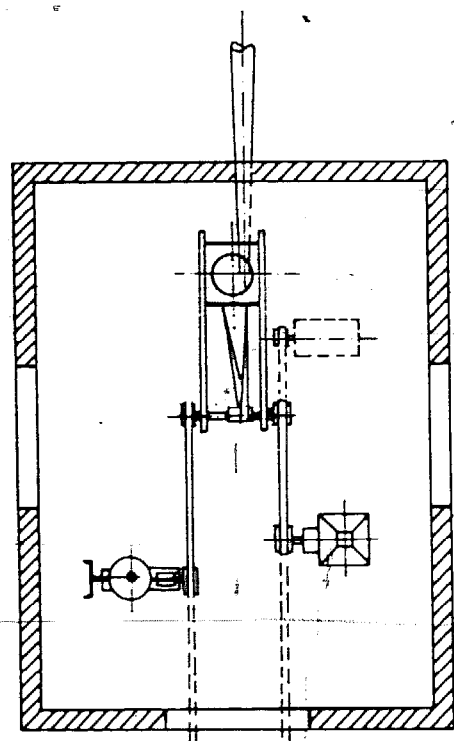

← FRONT SIDE POWER TAKE-OFF

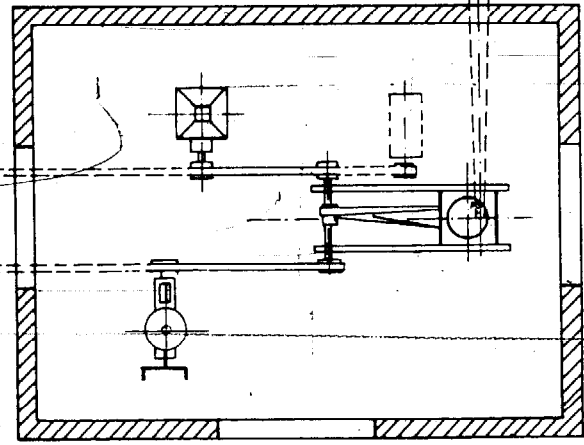

↑ LEFT HAND POWER TAKE-OFF

aba

MPPU • MILL HOUSE / STANDARD SIZE RH

RIGHT HAND POWER TAKE-OFF

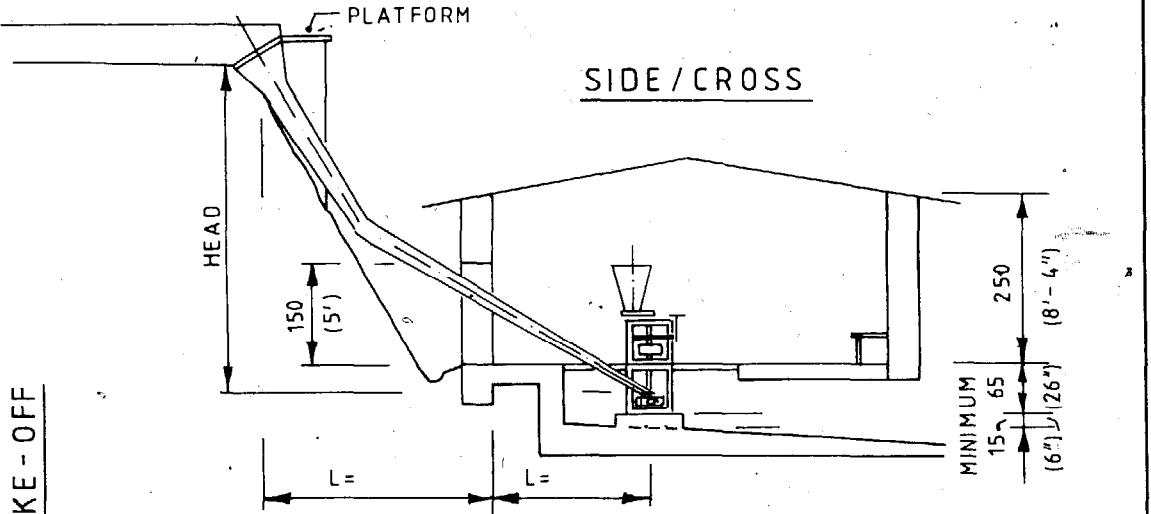

RIGHT HAND POWER TAKE-OFF

- A) MPPU, MILL & TURBINE
- B) POWER TAKE-OFF DEVICE
- C) RICE HULLER
- D) OIL EXPELLER
- E) ALTERNATOR
- F) MANHOLE
- G) TAILRACE
- H) INTAKE WITH GRILL
- I) PENSTOCK (PIPE)
- J) SPILLWAY (OVERFLOW)

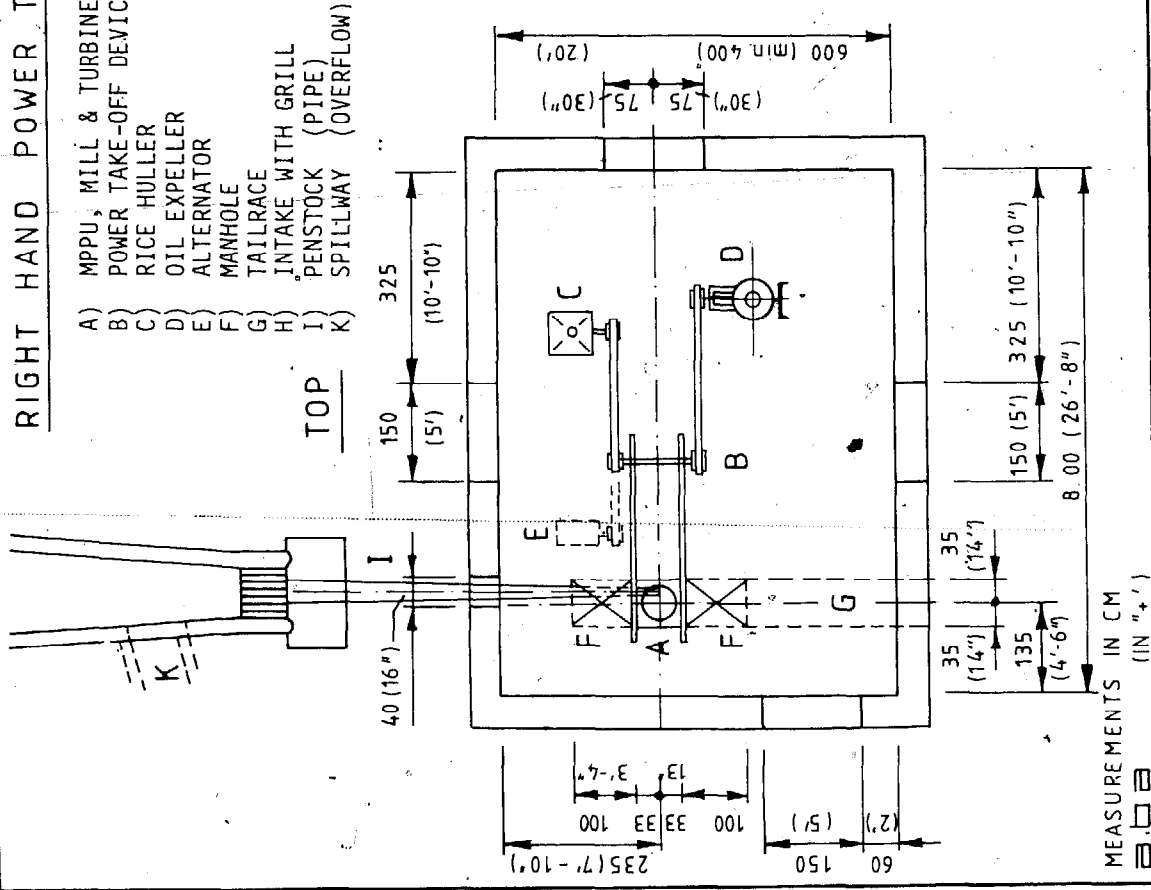

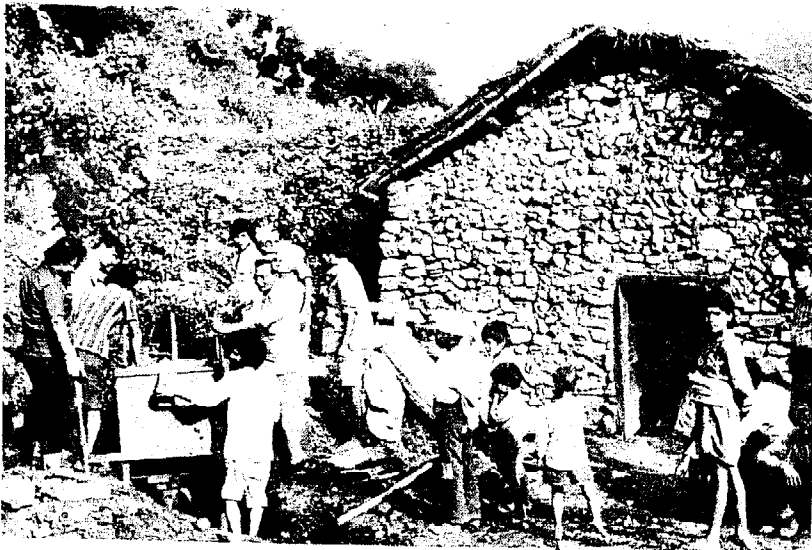

Set-up of pilot and trial plant at Godavari, Kathmandu Valley in September 1980.



Test runs with the newly installed MPPU for grinding, milling and a small dynamo.



The stones need to be redressed from time to time.



The traditional mill with horizontal water wheel at Thaibo, Kathmandu Valley.



First stage of installation of another MPPU set-up.

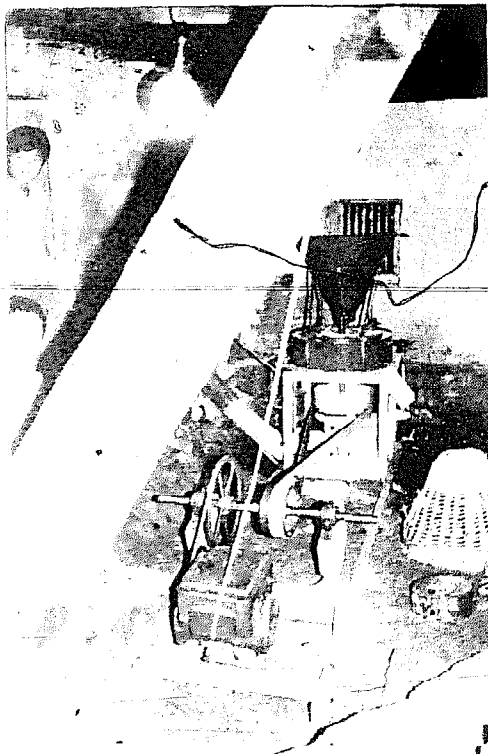

The test run at Thaibo, the first light with the own dynamo! Head = 2.4 m, Waterflow appr. 80 l/sec.

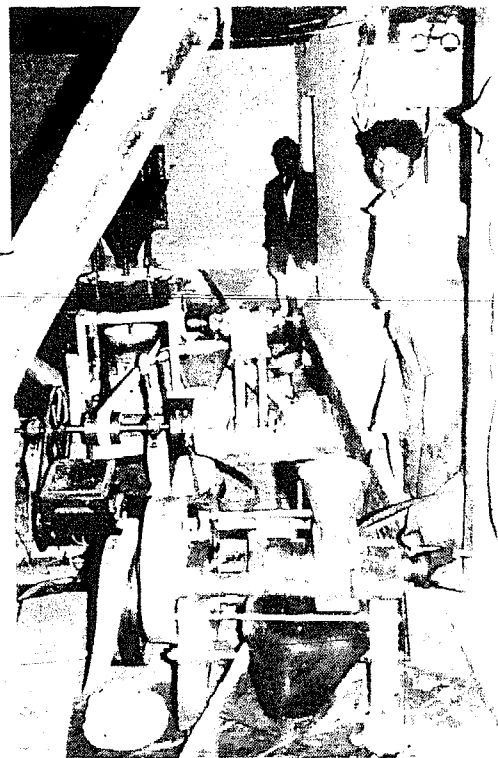

Additional machines have been fixed: rice huller and oil expeller.



Mill at Thaibo: note the small DC generator attached to the frame.

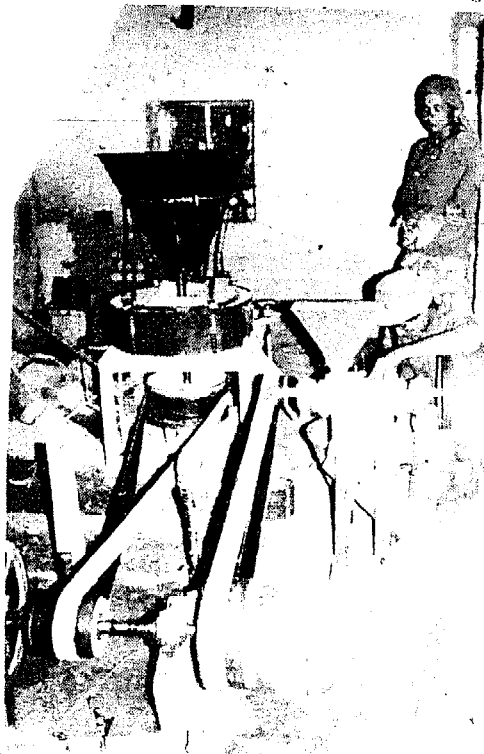

MPPU running the rice huller.



The miller's son operating the rice huller machine.



A welcome addition: a temporary fitted wheat thresher for seasonal requirement.

A traditional water mill with shed at Pheding, at approx. 4000 mtr. altitude. The grinding capacity is quite low and people are waiting in the cold for their turn at grinding.

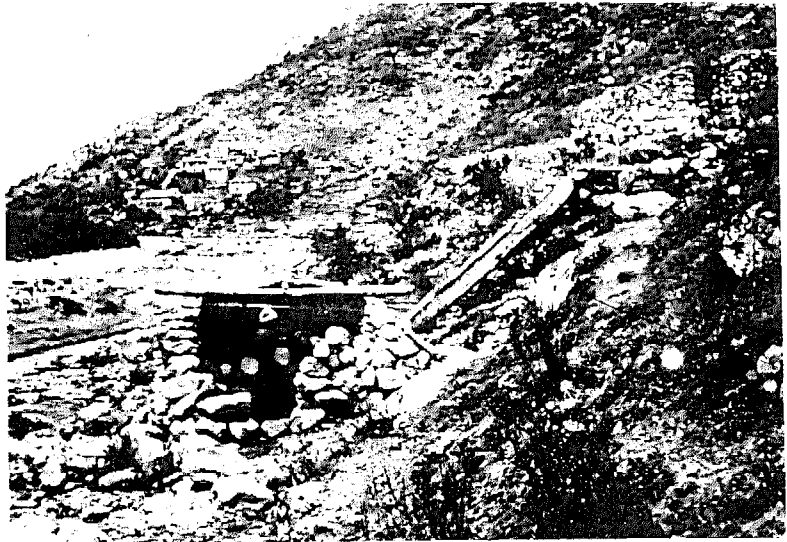

The grinding stone set-up.

A traditional horizontal water wheel, where no iron is used; the bottom needle is a stone!





MPPU turbine part at Namche Bazar, at the site of a traditional mill. The square pipe is made of wood. (Project and photo: M.Crawford).



A close look at a good quality horizontal water wheel, made of wood.

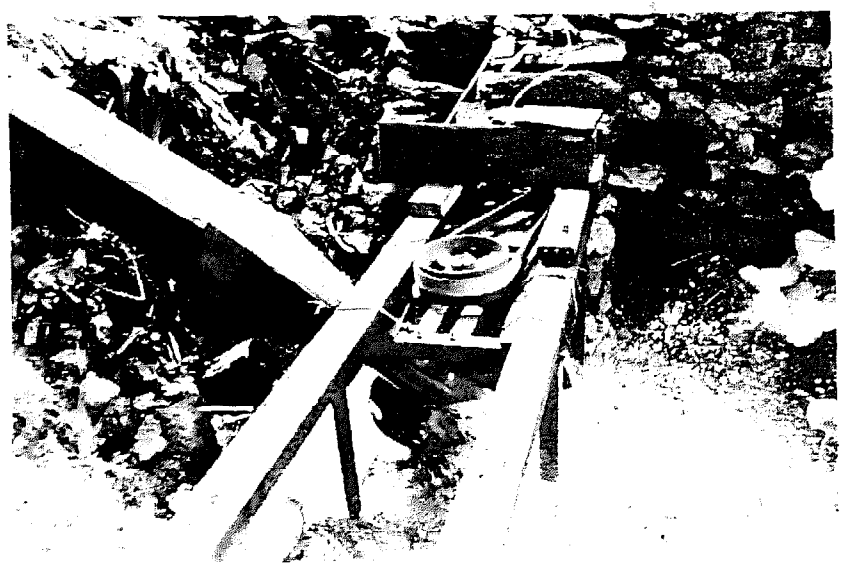

The pilot plant run a small DC. dynamo, generating light for a few houses. The MPPU turbine can generate several horse power, where head and water is available.



Reviving traditional milling technology: the appr. 100 years old mill house at Namseling near Thimphu / Bhutan

The renovated mill house in Namseling, November 1981. On the left side the upper part of the MPPU, people are transporting the circular saw.



The mill house from the side. On the left side of the house one can see the intake and the pipe. Head = 4 mtr, water flow appr. 100 ltr/sec. With this the MPPU can run the mill, oil expeller and a small dynamo at the same time!



The turbine of the MPPU



Installation works at site

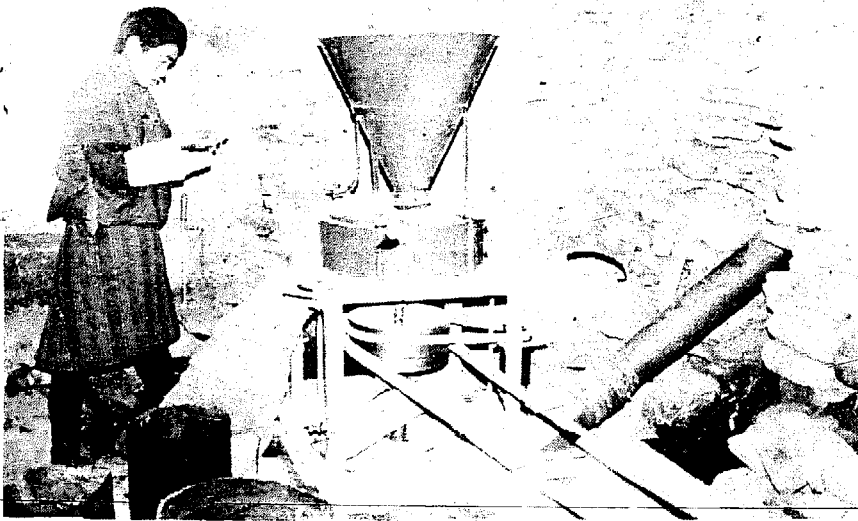

The first customer checks his freshly ground flour.

Adjustment of the oil expeller. On the left are the circular saw and the planing machine.

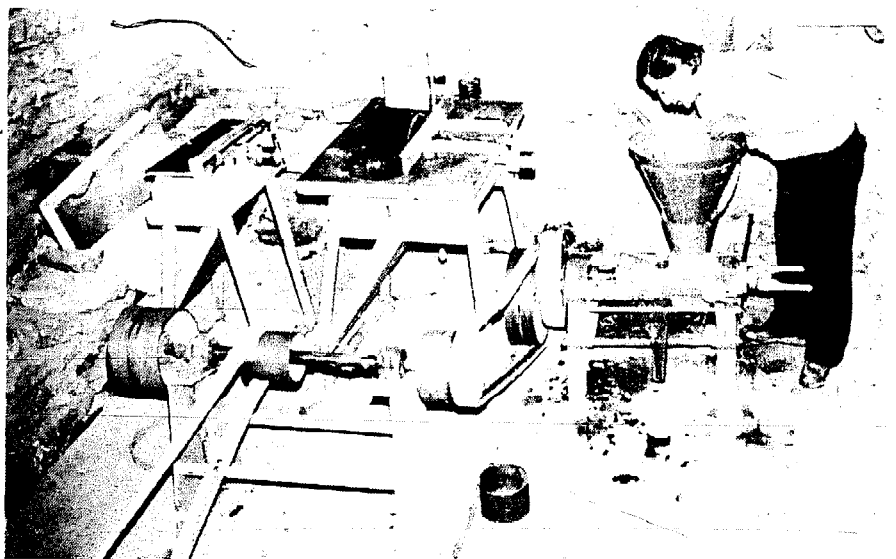

Transportation of MPPU parts is quite easy. The modular concept and standard sizes facilitates the use of different means of transportation.

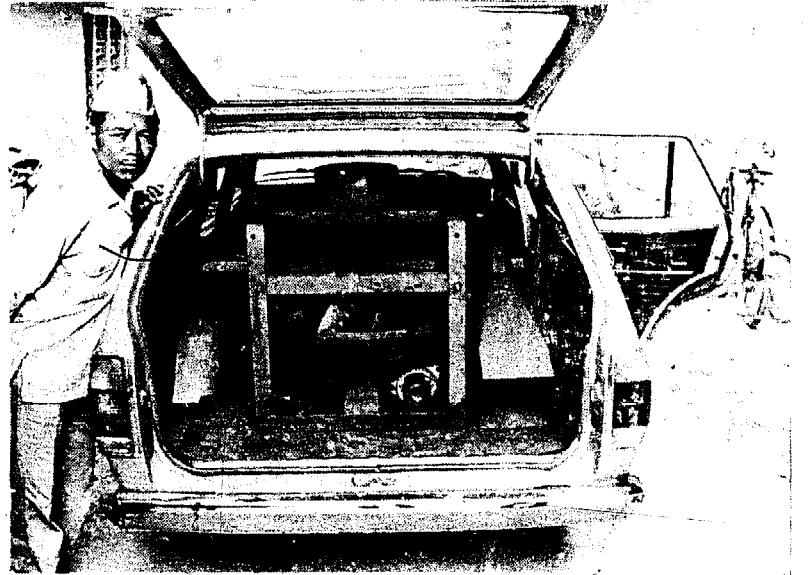

Pilatus porter flight to Lukla with the MPPU turbine.

MPPU's are made in portable loads, which can be assembled easily at the site.

(Project and photo:M.Crawford)





Assembly of the turbine wheel.



Local manufacture of a low-head pipe flange.

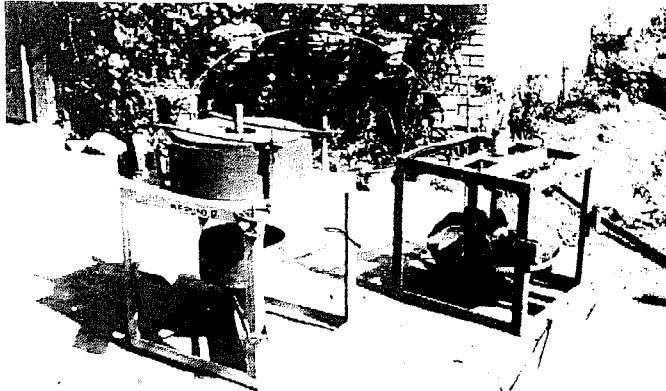

MPPU-set ready for dispatch from the workshop

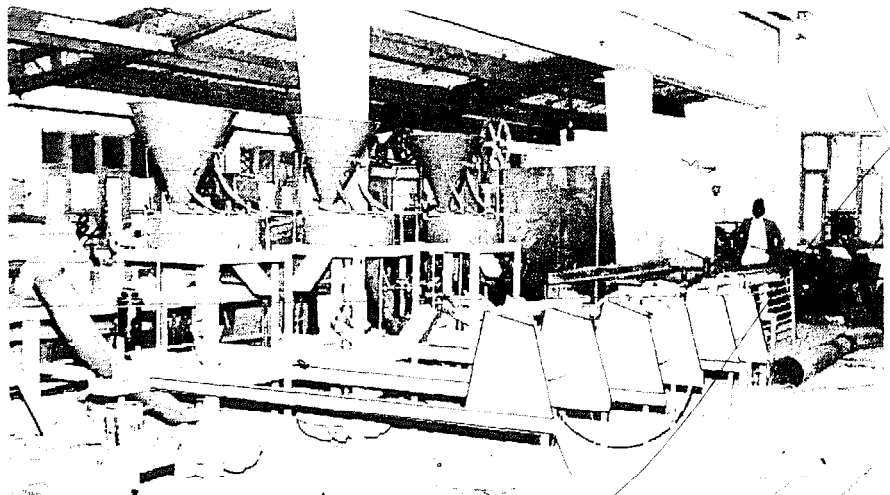

View of production at a workshop in Kathmandu.

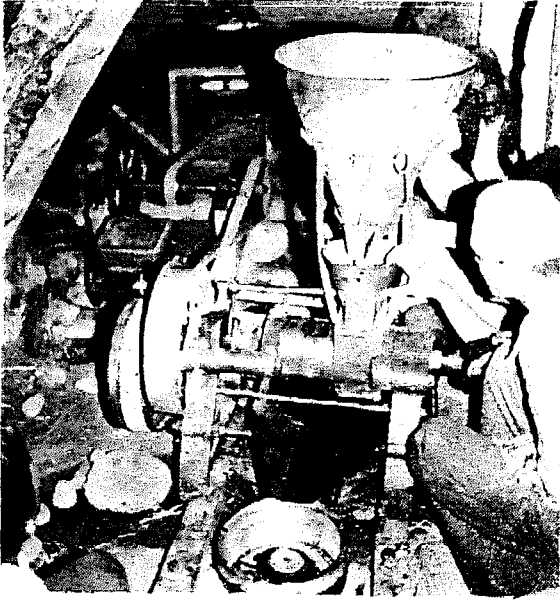

The MPPU can run various machines, for example
1 oil expeller,...



.... a rice flattener



.... a dynamo for small
scale electricity pro-
duction.

The improved milling device was introduced over twenty years ago and is fully satisfactory in hundreds of places, for the daily services for the people's needs.

Until recently they were run mainly by conventional diesel or electro motors.

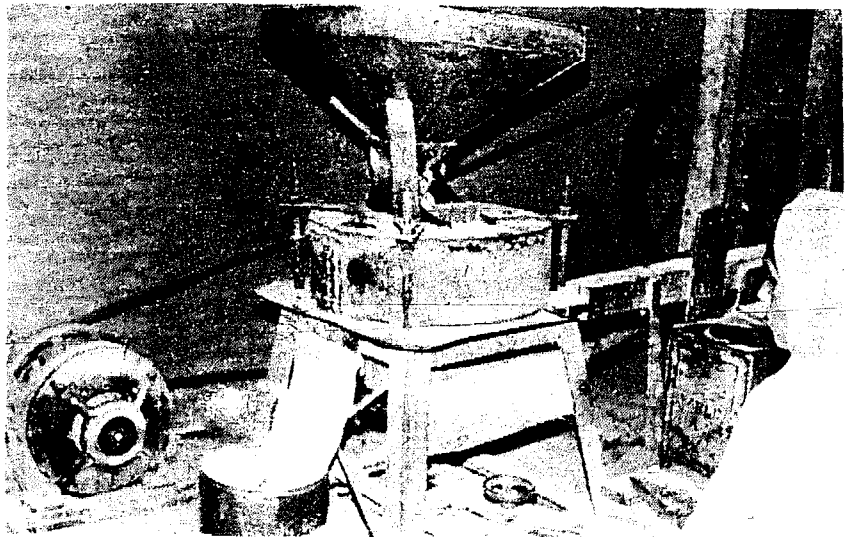



A MPPU-set ready for installation at Budhanilkantha. This is a community-owned mill, as a part of the "Small Farm Family Programme" (SFFP) of the Agricultural Development Bank/Nepal and UNICEF.

MPPU's fit quite easily into the existing structure of traditional mills.



MPPU has gained fast in popularity in rural areas: over fifty units were produced within less than two years, with exports to India and Bhutan.

Malekhu, a small bazaar on the Kathmandu-Pokhara Road has had for several years a larger turbine for agric. products processing. The photograph shows the mill house, the ground-floor (platform with people) is at the level of the turbines and the machines.

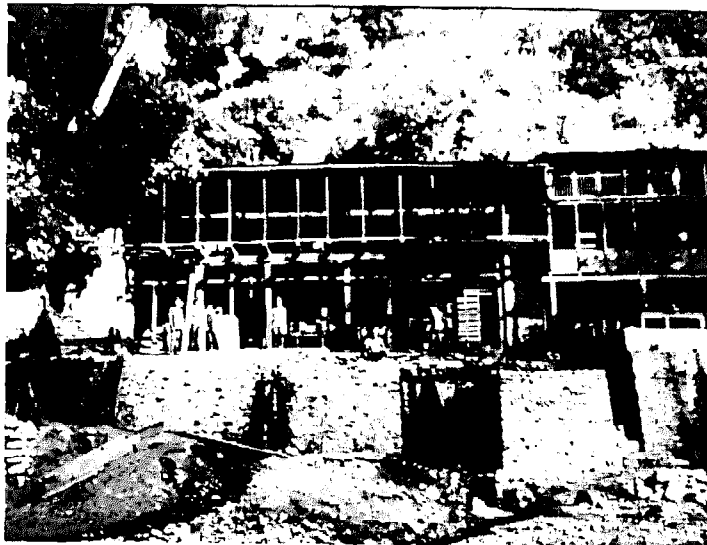

The clever miller realized that the water of the tail-race could also be used for small scale power production.

Mr. Shrestha, the mill owner of Malekhu discusses the installation of the MPPU turbine.

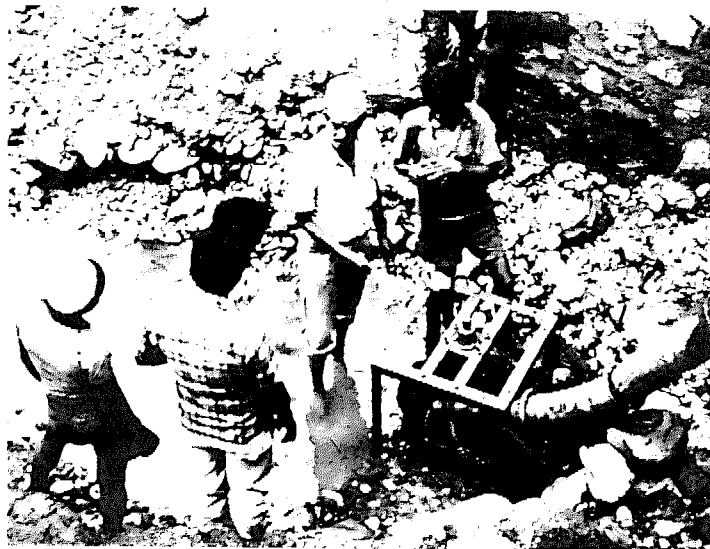

A extended shaft is installed, reaching the level of the ground floor of the mill house.

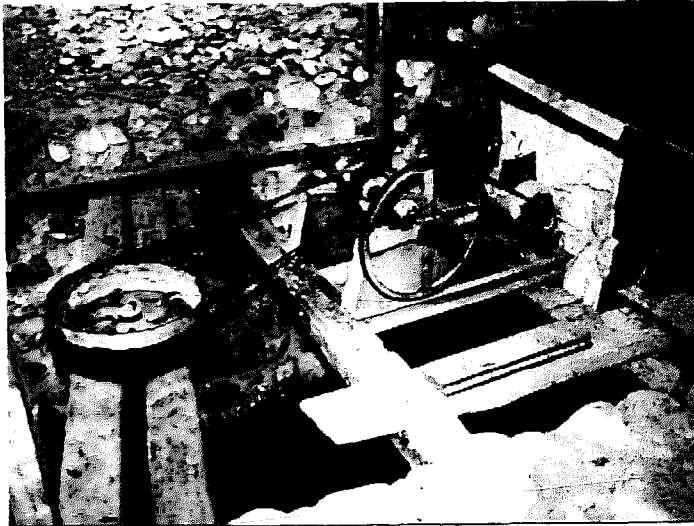
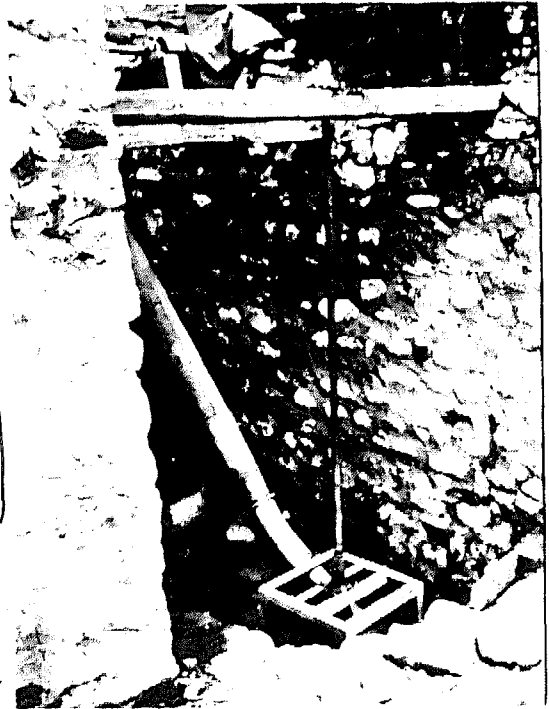

A small dynamo AC, 220-V supplies approx. 800 W.

Now the bazaar and/or the mill house receive electricity for lighting purposes.

The small MPPU turbine supplies quite a stable voltage, as there is no other machine connected to it except the dynamo.



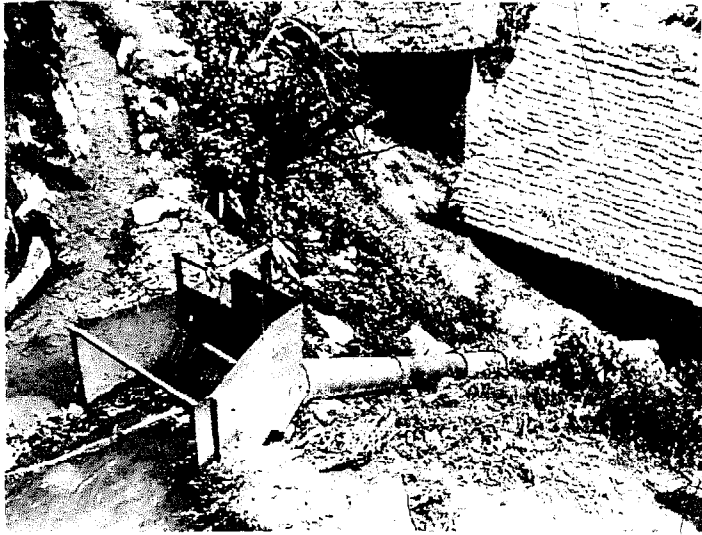

MPPU manufacturers provide a modular system with all necessary appliances. This photograph shows the intake with gate and grate.

An MPPU can turn very small and medium-sized milling machines. This installation houses the turbine, the grinding mill, a four-bolt oil expeller, a rice huller, a circular saw and a small dynamo!

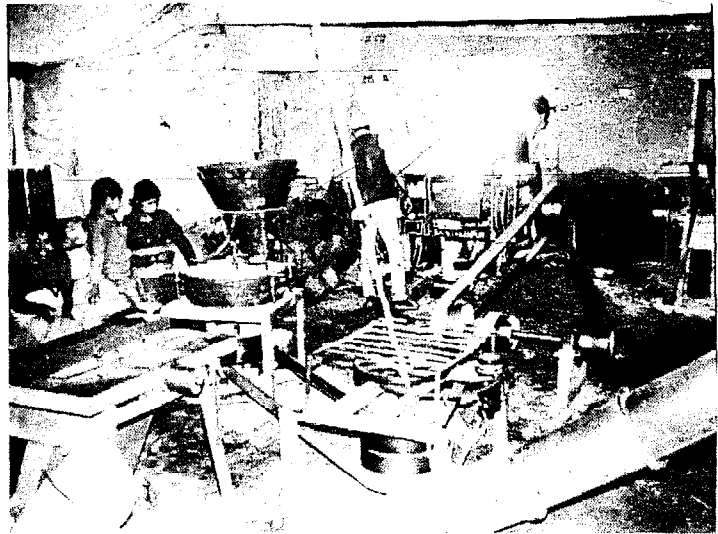

A improvement in the MPPU: a ring cover has been successfully added to the runner.

Now farmers in remote areas can also run additional agro-processing machines, such as a rice huller, from their traditional low-head water sites, with improved water mills. Note the stand on which the rice huller is fixed: the belt can easily be tightened by simply shifting the huller.

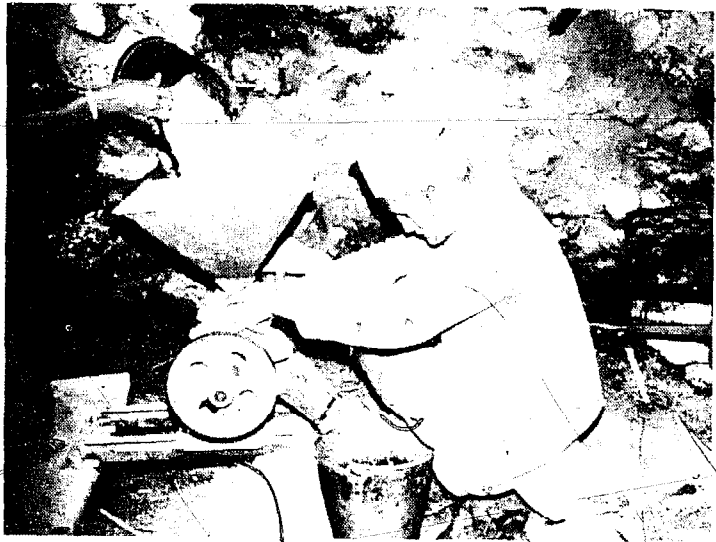

Trials with improved runner and natural stones are underway. Initial results are promising.

Low-cost dust-cover, with an improved runner, fixed by a miller: the faster speed produces more flour dust.

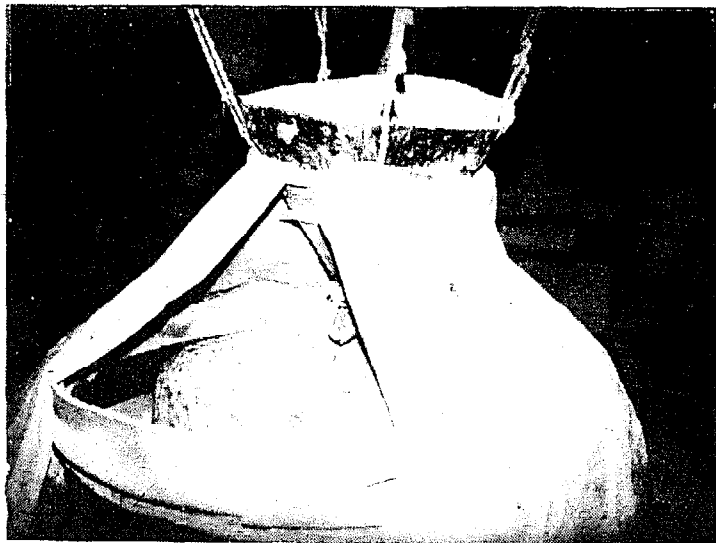

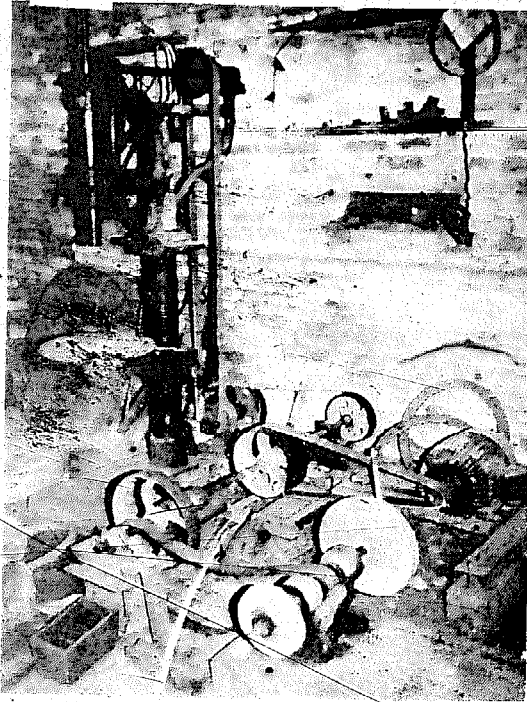

... equipment in a small workshop

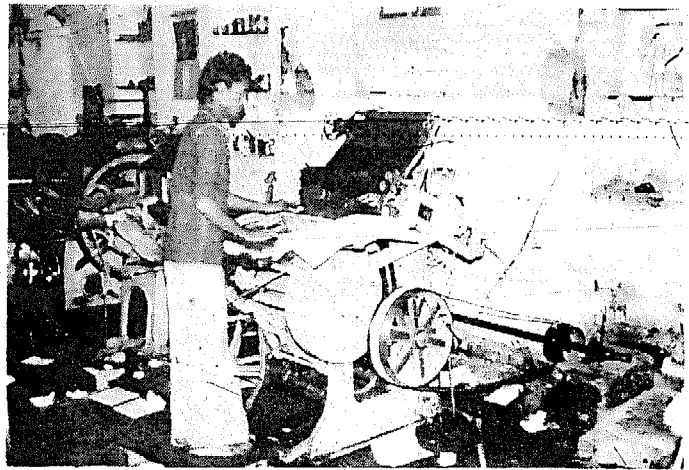

It is not always necessary to produce electricity to run machines with motors. Many machines on the market run successfully on belts, and they can be driven directly by small turbines (without motors).

for example: ...

... a small printing machine

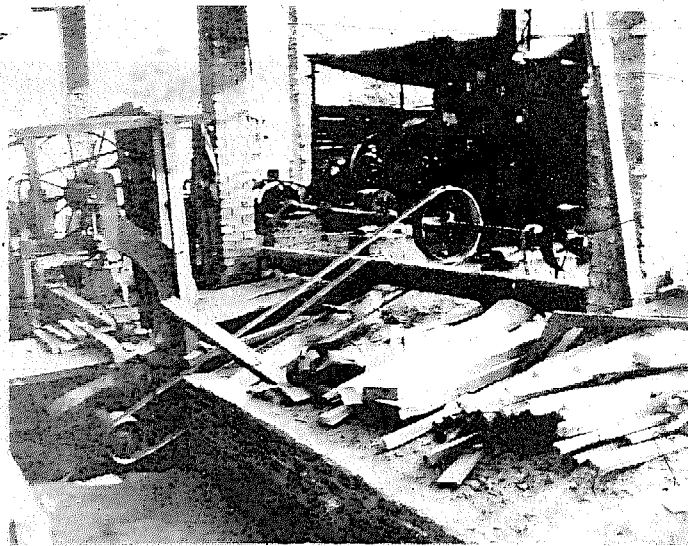

... a band saw for planks



... a lathe



Many people in the Himalayas require efficient utilization of small scale water power at low cost. Development of different turbines may hopefully bring the needed results. Here a low-cost, open cross flow turbine.

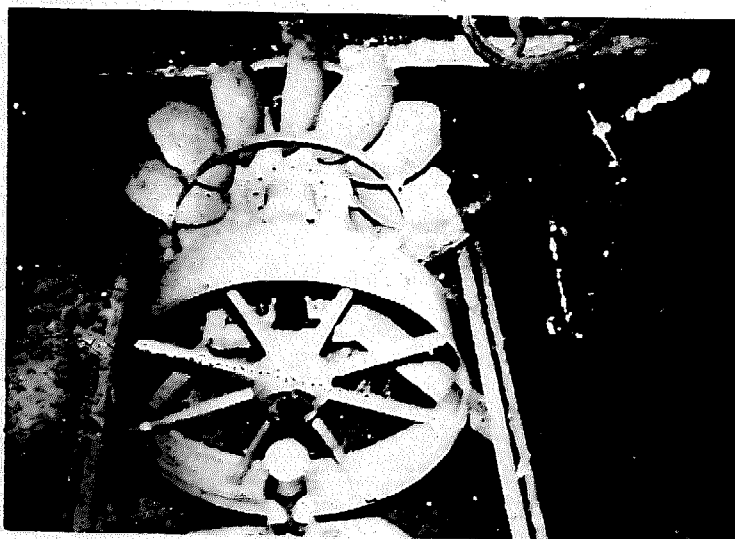

A pilot "metal-pelton" turbine with horizontal axle (using the same cups as the MPPU.)

Another device using alternate water power. One of the many water wheels with horizontal axle in Bhutan. They successfully run rice hulling machines.

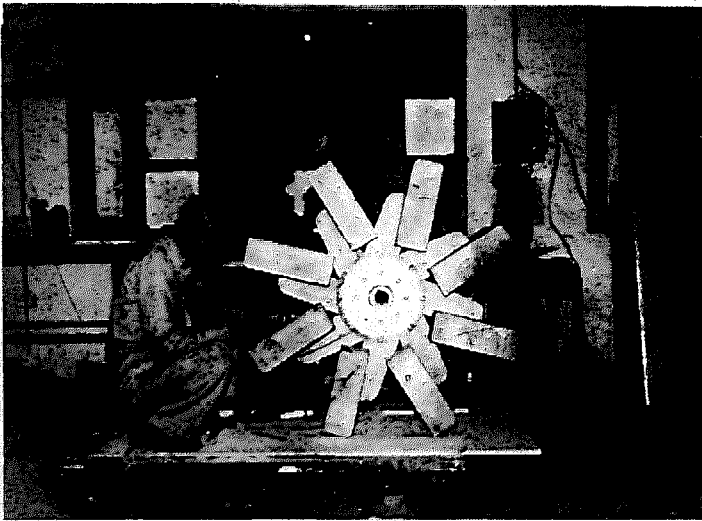
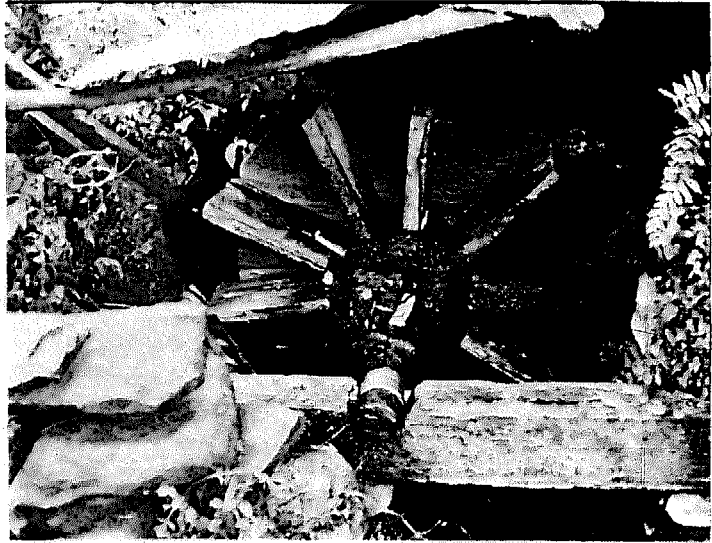

A prototype of an improved design: the frame holds curved blades, made of wood.

The "wooden pelton", installed at Namseling near Thimphu, Bhutan. First results showed, that even with the existing open chute, the productivity of the rice huller could be approximately doubled.





The potential of small scale water power systems in the Himalayas is great and with additional, improved small turbines a lot more can be made available in a short time for people in remote areas of these countries.



In any case it is certainly recommended to develop first the resources available at site. Photograph shows a diesel engine running a rice huller machine; a few meters away there are little-used traditional horizontal water mills!

MPPU HORSE POWER REQUIREMENTS (H.P.)				
S.No	MACHINE TO BE INSTALLED	R.P.M.	H.P. PER MACHINE	HP at SITE INSTALLED
1	GRINDING DEVICE, 610 mm ϕ (capacity 75 kg/hr) (capacity 1 Muri /hr)	200- 500	2.5 - 5 *	
2	RICE HULLER, No. 5 (cap. 90 kg/hr; 1/4 Muri/h)	600- 750	2.5 - 5 *	
	RICE HULLER, No. 4 (cap. 250 kg/hr, 3 Muri/hr)	1000	5 - 10 *	
3	OIL EXPELLER, No. 3 3 BOLTS, appr. 150 kg. (cap. 15 kg/hr; 1/4 Muri/h)	400	3 - 5.*	
	OIL EXPELLER, No. 5 4 BOLTS, appr. 350 kg (cap. 45 kg/hr)	175	5	
	OIL EXPELLER, No. 6 BOLTS 6 BOLTS, appr. 450 kg (cap. 60 kg/hr)	175	7.5	
4	CHURA MILL (RICE FLATTENER) - 75 cm ϕ (size 3 HP) (cap. 75 kg/hr; preboiled)	200	3 - 5 *	
5	THRESHER MACHINE (cap. 800 kg/8hrs. a day)	400	1 - 2.5 *	
6	CIRCULAR SAW, 350 mm ϕ (max. cutting 125 mm)	1500-2000	2 *	
7	PLANING MACHINE (max. width 150 mm)	2000-3000	1 *	
8	WOOD TURNING LATHE (max. 300 mm ϕ) (max. 600 mm length)	100- 300	1 *	
9	DYNAMO, DC. 12 V, 400 W, appr.	1000-1200	1/2 *	
10	EL. GENERATOR, AC. 220 V, appr: 1 kW	2800	1.3 *	
11				
* ADD 10% FOR FRICTION LOSSES				

MPPU • SURVEY REPORT		DATE: SURVEYOR:
1	APPLICANT'S NAME AND ADDRESS	
2	PLACE WHERE THE MILL WILL BE INSTALLED	
3	NAME OF THE RIVULET	
4	NEAREST MOTORABLE ROAD	
5	DISTANCE TO BE WALKED AFTER MOTORABLE ROAD	
6	HORSE POWER AVAILABLE	
7	TIME TAKEN FOR SURVEYING	
8	HEAD AVAILABLE	
9	ANGLE OF PENSTOCK (PIPE)	
10	LENGTH OF PIPE	
11	WATER QUANTITY	TIME OF SURVEY
		MONTH OF MARCH/APRIL
12	MACHINES TO BE INSTALLED	a)
		b)
		c)
		d)
13		
NOTES / SKETCH		
<p><u>TERMS & CONDITIONS:</u></p> <p>a) MPPU will be ready six to eight weeks after receipt of deposit, from the date of advance received,</p> <p>b) above quoted prices are ex-factory, valid for two months from date of issue,</p> <p>c) all additional costs, such as transport, lodging of technicians, and other expenditures to be borne by the party ordering the mill,</p> <p>d) guarantee on MPPU is one year, if installed by factory technicians.</p> <p>e) order becomes valid after payment of a deposit of 25 percent of the price quoted above.</p>		

MPPU QUOTATION		DATE:	
A	APPLICANT'S NAME AND ADDRESS		
B	PLACE OF INSTALLATION		
C	HORSE POWER AVAILABLE		
S.No.	pcs.	Unit Price	Total
1	MPPU, TURBINE & MILL, size... HP.	Rs.	
2	PENSTOCK (PIPE)mm ϕ at Rs..... /mtr, Total L.... mtr	Rs.	
3	INTAKE, for capacity of ltr	Rs.	
4	POWER TAKE-OFF DEVICE, HP.	Rs.	
5	DYNAMO, DC W	Rs.	
6	ELECTRIC WIRE, BULBS, ETC	Rs.	
7	TOOLS, SET	Rs.	
8	FOUNDATION BOLTS, 6 pcs for MPPU	RS.	
9	BELT, 50 mm, 5 ply for MPPU Power take-off Device 7 mtr at Rs.....	Rs.	
	SPARE BELT	Rs.	
	BELT FASTENER, 6 mm ϕ , ...pcs	Rs.	
10	WOODEN BEAM 100 x 100 mm x 3 mtr, 2 pcs....	Rs.	
	WOODEN PLANKS 200 x 25 x 1.5 mtr, 8 pcs	Rs.	
	NAILS, NUTS & BOLTS, COACH SCREWS	Rs.	
11	SPARE PARTS - -	Rs.	
12		Rs.	
	TOTAL MPPU		Rs.
13	TOTAL APPLIANCES, (acc. sep. sheet)		Rs.
14	SURVEY CHARGE	Rs.	
15	MILL INSTALLATION & APPLIANCES	Rs.	
16	TRAINING FOR MILLER for ... days	Rs.	
17			
	TOTAL MISC.		Rs.
GRAND TOTAL OF MPPU-INSTALLATION			Rs.

MPPU QUOTATION FOR APPLIANCES			DATE:	
A	APPLICANT'S NAME AND ADDRESS			
B	PLACE OF INSTALLATION			
C	HORSE POWER AVAILABLE			
S.No.	pcs.		Unit price	Total
1		RICE HULLER, No. - Stand - Spare Parts	Rs. Rs. Rs.	Rs.
2		OIL EXPELLER, BOLTS/... HP - Spare Parts	Rs. Rs.	Rs.
3		CHURA MILL (RICE FLATTENER) ...HP - Spare Parts	Rs. Rs.	Rs.
4		DYNAMO, DC or AC - Volts / Watts - Fixation / Pulley	Rs. Rs.	Rs.
5		EL. WIRE, BULBS, ETC. - - -	Rs. Rs. Rs.	Rs.
6				Rs.
7				Rs.
8		FOUNDATION BOLTS - for rice huller, 4 pcs at Rs. - for oil expeller, 4 pcs at Rs. - for pcs at Rs. - for pcs at Rs.	Rs. Rs. Rs. Rs.	Rs.
9		BELTS, 50 mm, 5 ply - for rice huller, 6 mtr at Rs. - for oil expeller, 6 mtr at Rs. - for mtr at Rs. - for mtr at Rs. BELT FASTENER, 6 mm ϕ , pc at Rs. BELT PASTE, TIN pcs at Rs.	Rs. Rs. Rs. Rs. Rs. Rs.	Rs.
10		NAILS, NUTS & BOLTS, COACH SCREWS		Rs.
11				Rs.
12		INSTALLATION		Rs.
TOTAL MPPU-APPLIANCES				Rs.

MEASURING THE HEAD

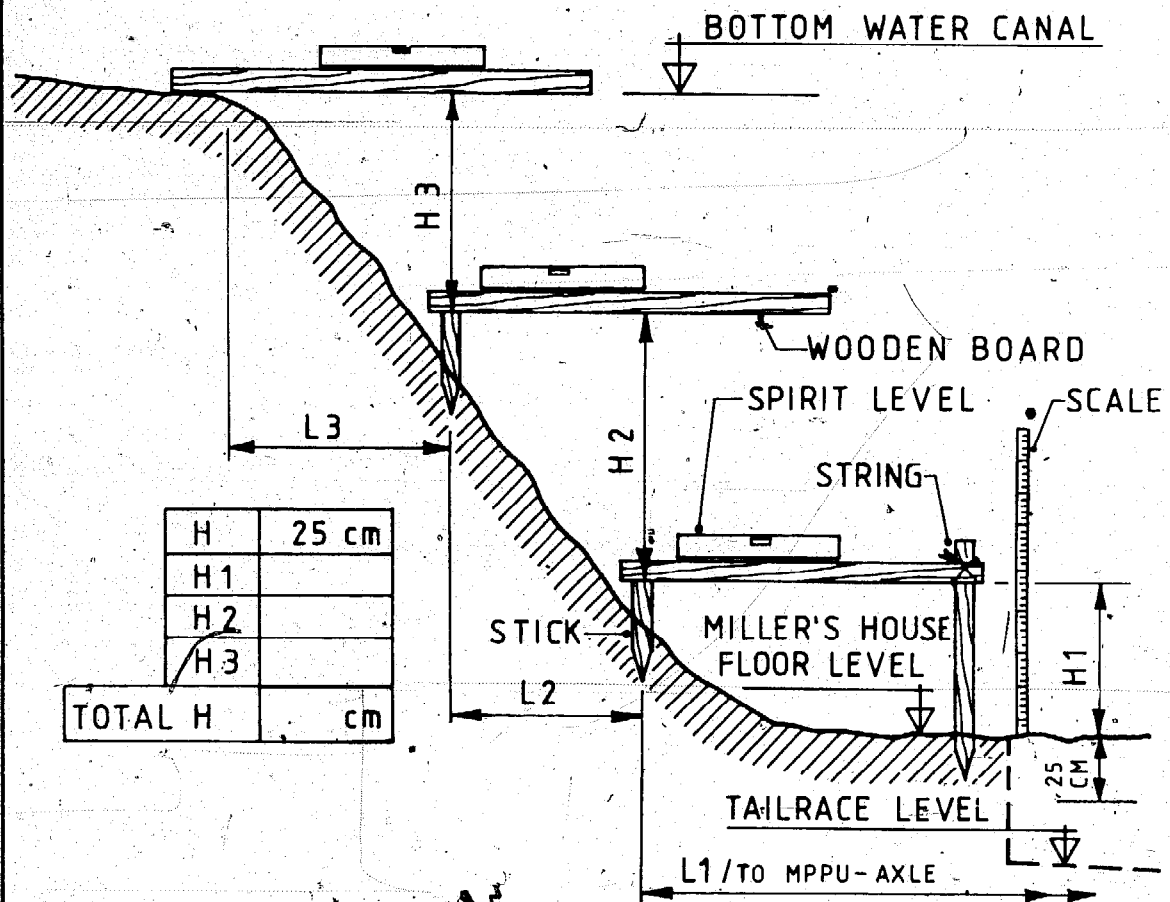

Measurement of a vertical distance (plumb-line) can be done quite simply. One requires:

- 1 spirit level
- 1 steel measuring tape (or a folding rule)
- 1 wooden board, 180 cm long, 2.5 x 5 cm
with two edges planed parallel
- 1 Stick, appr. 150 - 200 cm long
- 2 wooden sticks, appr. 25 cm long
- 1 C-clamp, or string

The results will be sufficiently accurate with necessary care in levelling and measuring. Some differences in length of the penstock (pipeline) can be adjusted within the range of the bottom piece near the turbine; as it has moveable pieces.

Note: Measurements of head and length (horizontal) are required for the definition of the angle of the bends (pipe).

MEASURING OF FLOW

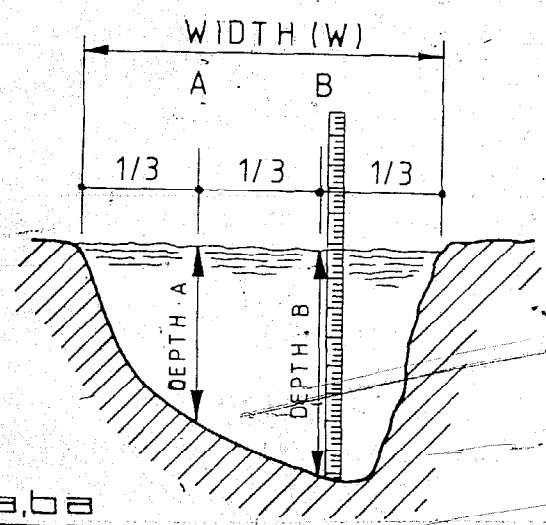
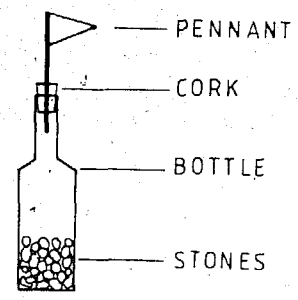
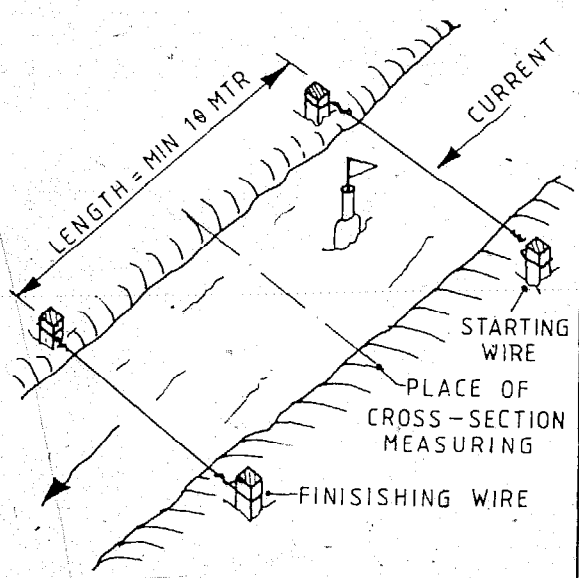

1. Select a length of rivulet with approximately parallel sides, and smooth surfaces (no rocks) for a distance of at least 10 meters.

Fix two strings (or wires) across the rivulet; one at the beginning and another at the end of the distance to be measured.

2. The float can be a bottle, filled with stones or sand, so that it floats vertically. For easy following of the bottle a small flag can be fitted on the bottle.

3. Then measure the time needed for the bottle to travel the distance between the two strings -beginning just when the float passes the starting string and stop timing when the float is passing the finishing string.

4. Calculation: one has to measure the cross sectional area of the rivulet (see sketch):
Cross Sectional Area:

$$\text{Width of Rivulet dam} \times \left[\frac{\text{Depth A} + \text{Depth B}}{3} \right] = \text{Mean Depth} = \text{Cross Sectional Area} \text{ dm}^2$$

RATE OF FLOW; in ltr/sec (cft/sec)

Average Cross Sectional Area	x	Frictional effect on channel	x	Rate of Flow (Vel.)
dm ² (sqft)		(multiply with 0.75 for earth; with 0.6 for rocks)		dm/sec. (ft/sec)

SAMPLE:
Distance to travel = 10 m = 100 dm.
Time to travel = 20 sec.
Velocity of flow = 100 dm / 20 sec = 5 dm/sec.

Cross sectional area:
Depth A = 40 cm = 4 dm
Depth B = 80 cm = 8 dm
Mean depth = (4 + 8) / 3 = 4 dm
W x Mean depth = 7 dm x 4 dm = 28 dm²

RATE OF FLOW, in ltr/sec.
28 dm x 0.75 x 5 dm/sec = 105 lt/s.

CONVERSION TABLES

MPPU

to change	into	multiply by.
ft	in	12
ft ³	ltr	28.3
ft	m	0.305
Imp. gal.	ltr	4.54
in	cm	2.54
lb	kg	0.454
kg	lb	2.3

1 horse power (H.P.) = 746 Watts = 0.746 kW
 1 kilowatt (kW) = 1000 Watts = 1.34 H.P. (english)
 1 foot = 12 Inches = 30.5 cm
 1 yard = 3 feet = 91.4 cm
 1 square foot = 144 sq.in. = 9.29 sq.decimeters
 1 square meter = 1.196 square yards
 1 cubic inch = 16.4 cubic centimeters
 1 gallon (imp). = 4 quarts = 4.54 ltr

Avoirdupois Weight:

20 Pathi = 1 Muri
 1 Pathi = 8 Mana
 1 Muri = 75 kg for Wheat, Maize, Paddy
 1 Muri = 60 kg for oil seeds
 5 Pathi Maize fed to mill gives 7 Pathi Flour
 25 Pathi rice weighs 100 kg
 1 Muri of oil seed = 20 ltr of oil
 1 ltr oil = 1/20 Muri of Mustard oil

MPPU • COMPARISON WITH TRADITIONAL MILLS

TRADITIONAL WATER MILL
(GHATTA)

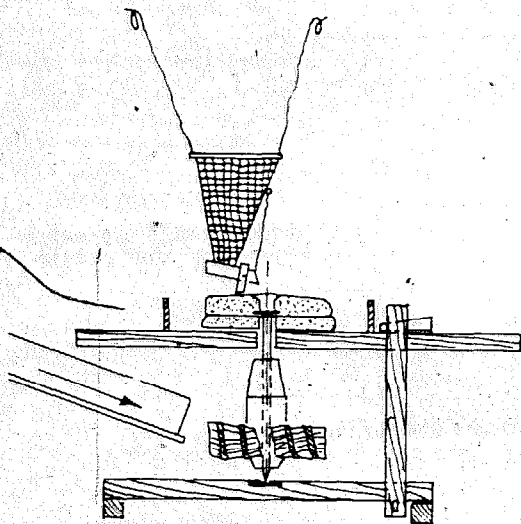

MULTI-PURPOSE POWER-UNIT
(M P P U)

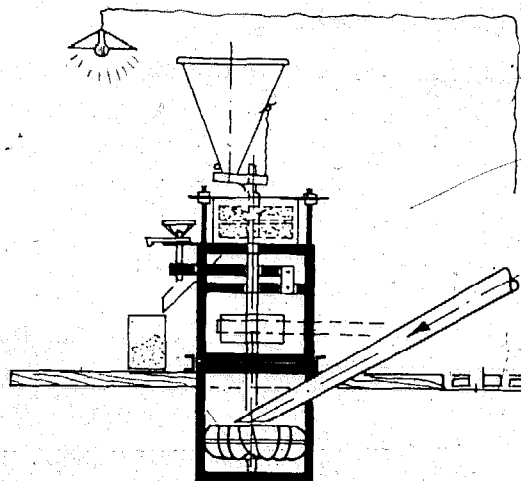

NOT SHOWN: POWER TAKE-OFF DEVICE
TO RUN ADDITIONAL MACHINES.

	Traditional Water Mill	Multi-Purpose Power-Unit
Purpose	Grinding	Grinding, Multipurpose with Power Take-Off Device, for: - small scale agric. processing - small scale cottage industry - small electricity generation (e.g. 12 V, DC, appr. 400 W, or 220 V, AC, 1-2 or more kW)
Water Quantity	min. 80 ltr/sec.	min. 60 ltr/sec.
Head	3-5 mtr (max. open chute)	3 - 20 mtr (and more) Penstock
R.P.M.	appr. 160	appr. 250 - 300 ($\pm 20\%$)
Horse Power	appr. 1	2.5 - 5, 10 and more, depending on water quantity and head available at site.
Grinding Capacity; Maize	appr. 12-14 kg/hr	appr. 65-95 kg/hr, and more
Durability of Mill	reasonable, especially in non-freezing areas	longer lasting, especially in higher altitudes.

MPPU • COMPARISON WITH TRADITIONAL MILLS		
	TRADITIONAL WATER MILL	MULTI-PURPOSE POWER-UNIT
Time of Introduction	centuries ago	improved grinding device over 20 years, in hundreds of places (driven with diesel or electro motors); with water turbine below since 1980
Number of working units	25,000 - 30,000	about 40 units (January 1983), and with several orders to be produced, exports to Bhutan and India.
Taste of Flour	usual, good	good and acceptable, quality is depending on speed of grinding and acceptance of flour taste also by the different localities.
Delivery Time	locally made, depending on available manpower, seasonal works.	six to eight weeks
Construction Materials	with local materials, mainly wood and stones; - open chute (canal) - pin as bottom bearing - flat wooden paddles - open grinding stones; flour needs to be collected around the stones	with locally available materials, mainly metal and stones; - pipe with intake and nozzle - ball bearing system - spoon-shaped, metal buckets - covered grinding stones; flour is automatically collected and proper outlet through spout.
Maintenance	Local craftsmen using local materials only	by trained manpower; much by the miller himself. Based on the traditional design experiences show that people can quite easily handle the new devices.
Transportability	Produced at the site	made in modular and standard sizes, kept in porterable loads which can be quite easily assembled at site.
Costs	approx. Rs. 2500 - 3500/- (US \$ 180 - 215.00) incl. shelter, not counting the labour expenses	Depending on local requirements for additional machines, for mill-set only, incl. pipe, power take-off device and DC dynamo, approximately Rs. 46,500 (US \$ 1200.00) excl. transportation, installation, training of manpower, etc.
<p>Note: There are also several efforts going on for the improvement of traditional water mills using more local materials. The first results are quite promising and people interested in even lower-cost devices!</p>		

GLOSSARY

MPPU

ALTERNATING CURRENT (AC)	<p>Electric current which changes its intervals, normally making 50 cycles per second. AC is easier to transmit than Direct Current (DC), and thinner cables can be used.</p> <p>Note: -AC, 220 V is more dangerous than 12 V DC -AC-generators need governors where the load may vary (and makes small plants more costly - Normal el. motors need AC current.</p>
ALTERNATOR	Dynamo (Generator) giving alternating current.
AMPERE (Amp)	The rate of flow in an electric current.
AMPERE - HOUR	<p>Unit of electrical charge, equalling the quantity of electricity flowing in 1 hour past any point of a circuit carrying a current of 1 Amp.</p> <p>Storage batteries are related in ampere-hours to show the quantity of electricity that can be used without discharging the battery beyond safe limits.</p>
GATE	(SLUICE) In a canal, a structure of vertical sliding board or metal that controls the flow of water.
GENERATOR	Machine for converting mechanical into electrical energy; dynamo; alternator for AC current.
GHATTA	Nepali word for traditional mill.
GOVERNOR	Automatic regulator of machine, ensuring uniform motion; mechanical or electronic devices are available, essential where el. installations with AC current are done.
DIRECT CURRENT (DC)	<p>Electric current which flows in one direction. DC current is produced by dynamos or generators.</p> <p>Note: DC current is less dangerous than AC, and for small installations no governor is needed. El. wiring needs to be of thick diameter!</p>
DYNAMO	Machine converting mechanical into electrical energy, DC or AC.
EFFICIENCY	A measure of how much of the energy applied to a device is utilized in useful work. For example: if an electric motor is rated at 80 percent efficient, the 80% of electrical energy is converted into mechanical motion and the remaining 20 percent is dissipated as heat.

GLOSSARY

MPPU

ENERGY	The ability to do work. Units of energy are: kilowatt-hours (kWh), British Thermal Units (Btu), and horsepower-hour (hph).
HEAD	The vertical distance of that level above another point; the resulting pressure of that water at some lower level; as the turbine of the water canal (Intake).
HOPPER	Cone or inverted pyramid through which the grain passes in the mill.
HORSE POWER	A measure of the rate doing work, equal to .7455 kW. (745.5 W)
INVERTER	A device for converting direct current (DC) into alternating current (AC).
KILOWATT (kW)	A unit of power equal to 1000 Watts.
mtr / sec. - m/s.	Meters/second, velocity in meters per second.
MOTOR	Machine supplying motive power; what imparts motion.
MPPU	Multi-Purpose Power-Unit, improved traditional horizontal water mill, metal construction, 2-5, 10, 15 HP. Developed in Nepal, 1980
PENSTOCK	(PIPELINE) The water conduit in a canal (or dam) that connects the Intake to the turbine or water wheel.
POWER	The rate of doing work. Units of power are: kilowatts (kW), British thermal units per sec., horsepower (HP).
PULLEY	Wheel or drum fixed on shaft and turned by belt; used to pass over power and especially to increase speed or power, and also for changing direction of power.
R.P.M.	Revolutions per minute, rotation.
SPILLWAY	Passage of surplus water from intake; dams.
TAILRACE	Part of mill race below water wheel.
TURBINE	The "water-wheel", made of metal is called a turbine wheel. Water-wheel driven by impact or reaction or both of a stream of water.
VOLT	The unit of electromotive force in an electric circuit

NOTES

THE ADVENT OF THE WATER TURBINE

... The vertical shaft Pelton Wheel is a comparative newcomer to the water turbine world and is an interesting reversion to the basic principle of the earliest of the horizontal mills. The Pelton wheel itself, a steel casting with its huge "buckets" ground to a mirror finish with great accuracy of profile, is secured to the bottom end of the shaft.

Water under high pressure flows through the nozzle and strikes the buckets as it did in the mill at the Escorial. In place of the upper grindstone the rotating part of an electric generator is secured to the upper end of the shaft.

It is interesting to reflect that whereas the wheel of Antipater did the work of one or two girls, each vertical shaft Pelton Wheel at Kemano in British Columbia has a wheel 13 ft. 6 ins. in diameter and does the work of 140,000 horses. The head is 2,500 feet and this one power station working 24 hours per day, produces more energy than many millions of men. The watermill with a horizontal wheel has come back into its own!

"Watermills with Horizontal Wheels"
by Paul N. Wilson, 1960

CONSTRUCTION MATERIALS: WOOD / METAL

... Either sheet metal or wood is an acceptable material, but metal is better suited to cold climates, since wood is damaged when absorbed water freezes.

Cloudburst, 1973, page 51
Cloudburst Press Ltd. Box 79
Brachendale, B.C. V0N 2T0, Canada

...Turbines may be made of wood, though if there is a rudimentary iron and steel industry, these more enduring materials may be used.

Energy for Rural Development, 1976, p 155
National Academy of Sciences, USA

MACHINE SUPPLIERS IN INDIA:

- Rice Huller, OSTAD Brand, CHOPRA MACHINE, Corp. 27/ 2C Strand Road, Calcutta 1
Spareparts to be ordered with the machine: Huller blade
1 pc, Huller screen - 1 piece, bearing - 2 pieces.
- Oil Expeller, Baby size, with auto-feeding device, SAIMI ENGINEERING WORKS,
106/263 Kalpi Road, Kanpur -3
Spareparts to be ordered with the machine: Worm shaft-1 pc,
Bronze bush - 1 pc, bearings - 2 pcs, Cage bars (Patti) 20 p
- Dynamo, 12 V, DC. car shops, Spare parts to be ordered with el. generator:
Carbon brush - 1 pair, bearings - 2 pcs.
Spare bulbs, 12 V -25 or 40 W (e.g. OSAKA Brand, Calcutta)

REFERENCES

REFERENCES

- A NEW MULTI-PURPOSE POWER UNIT USES RENEWABLE ENERGY RESOURCES, Nepali design can grind grain or run other small machinery, VITA NEWS, Jan. 1981
- SMALL HYDEL DEVELOPMENT PROGRAM - PROGRAM EVALUATION, Final Report, by L. Krayenbuhl and E. Ledergerber, Kathmandu, Zurich, Jan. 1981
Direktion fuer Entwicklungszusammenarbeit und humanitaere Hilfe, (DEH), Eigerstrasse 73, CH-3003 Bern, Switzerland
- MICRO HYDRO IN THE EVEREST REGION - A MEASURE AGAINST DEFORESTATION, by M.T. Crawford, 1981, Paper presented to the 2nd international Conference on Energy for Rural and Island Communities, Inverness, Scotland, 1-4 September 1981.
- A MULTI-PURPOSE POWER-UNIT, Biogas Newsletter, Number 12, Spring 1981
- DEVELOPMENT AND DISSEMINATION OF RENEWABLE ENERGY RESOURCES IN NEPAL, by A. Bachmann & G.R. Shakya, 1981, paper presented to the International Solar Energy Congress, Brighton, England, 24-28 August 1981
- LOCALLY-FEASIBLE TECHNOLOGIES FOR THE RURAL AREAS OF NEPAL, by A. Bachmann & B.R. Saubolle, 1981, paper presented to the Seminar on Appropriate Technology for Hill Farming Systems, 22-25 June 1981, Kathmandu
- TRADITIONAL AND NEW TECHNOLOGY DEVELOPMENT IN BHUTAN - SOME THOUGHTS, by A. Bachmann, 1981, paper presented to the Workshop-Seminar on Development Planning and Tourism, Bhutan, 15-28 October 1981
- THE RISING NEPAL, local Newspaper, different articles: Multipurpose 'Ghatta' built (9 Sept. 1980), A "Ghatta" for all seasons (27 February 1981)
The Multi-Purpose Power-Unit, Bright Hope for Rural Energy (28 May 81)
Countdown!, by Kunda Dixit (14 August 1981)
- MPPU - PRELIMINARY CALCULATIONS AND COMMENTS ON ECONOMY, compiled by A. Bachmann, January 1982
- SMALL HYDROPOWER - IMPROVEMENTS ON THE WATER WHEEL IN NEPAL, RERIC-Newsletter, December 1981, Asian Institute of Technology, Bangkok.
- MULTI-PURPOSE POWER-UNIT FOR RURAL APPLICATIONS, RCTT Technical Digest, May-June 1981, Regional Center for Technology Transfer, Bangalore, India
- RENEWABLE ENERGY RESOURCES IN NEPAL, Proceedings of the Workshop-Seminar, Kathmandu, 1-4 April 1981, Publisher: Sahayogi-Tripureshwar, Recast
- MPPU - A COMPARISON - Traditional and Improved Horizontal Water Mills in Nepal, March 1982, Leaflet, A. Bachmann

FURTHER READINGS

FURTHER READINGS

- RENEWABLE ENERGY RESOURCES IN NEPAL, Proceedings of the Workshop-Seminar, Kathmandu, 1-4 April 1981, Publisher: Sahayogi-Tripureswar, Recast.
- THE MEDIEVAL MACHINE, by Jean Gimpel, Futura Publications Ltd. London
- WATERMILLS WITH HORIZONTAL WHEELS, by Paul N. Wilson, 1960, The Society for the Protection of Ancient Buildings, London.
- WINDMILLS AND WATERMILLS, by John Reynolds, 1970, Praeger Publisher, New York, USA.
- ON WATER MILLS IN CENTRAL CRETE, by N.G. Calvert, 1972, Excerpt Transactions of the Newcomen Society; The Society for the Protection of Ancient Buildings, London.
- MICRO-HYDRO POWER, Reviewing an old Concept, 1979, by National Center for Appropriate Technology, P.O. Box 3838, Butte, Montana 59701, USA
- LOW COST DEVELOPMENT OF SMALL WATER POWER SITES, VITA, Volunteers International for Technical Assistance, 3706 Rhode Island Avenue, Mt. Rainier, Maryland 20822, USA
- SMALL SCALE WATER POWER, by Dermont McGuigan, 1978, Prism Press, Dorchester, UK
- LOCAL EXPERIENCE WITH MICRO-HYDRO TECHNOLOGY, 1981, by U.Meier, SKAT, Varnbuelstr. 14, CH-9000 St.Gallen, Switzerland (Sfr. 32.-, appr. 16 US\$)
- SMALL HYDRO POWER PLANTS, 1978 (M: 1/12 - 10/78) General Information, +
- SMALL WATER TURBINE, Instruction Manual for the Construction of a Crossflow-turbine, 1980, H.Scheurer et al. (M: 1/13), available: GtZ / gate, P.O. Box 5180, D-6236 Eschborn -1, FR.Germany

* Trade Mark

The Multi-Purpose Power-Unit (MPPU) is a registered trade mark, as a name and as a product.

** Loans

For loan application contact the Agricultural Development Bank of Nepal in Kathmandu or a branch office

*** Validity

The description and pictorial representations used in this brochure are believed to be correct at the time of publication. The policy is one of continual improvement and all colours, materials, specifications and prices are therefore subject to change without notice or obligation.

FROM THE SAME PUBLISHER

MOUNTAIN ENVIRONMENT AND DEVELOPMENT

A collection of papers published on the occasion of the 20th anniversary of the Swiss Association for Technical Assistance in Nepal, 1976. This booklet has been reprinted several times and found world-wide distribution.

RENEWABLE ENERGY RESOURCES IN NEPAL

Proceedings of the Workshop-Seminar, Kathmandu, 1-4 April 1981, published by Sahayogi Press and Recast.

This collection of papers provides a good overall view of problems and possible solutions for urban and rural populations in Nepal.

DRINKING WATER INSTALLATIONS AND DRAINAGE REQUIREMENTS
IN BUILDINGS IN NEPAL, by A. Bachmann

This book is based on many years of experience in sanitary engineering. The collection includes installations of low- and medium-pressure water supply, waste water and gas. Included also is valuable experiences of locally-produced solar water heaters. The presentation is clear and has many technical drawings and is made for architects and planners as well as for technicians working at building sites; all with reference to conditions to Nepal and useful to many other countries. (Several times reprinted, revised edition).

HOME BREW, by B. Remi

A delightful booklet, explaining how to make beers and wines. Written in a light vein, it is profusely and humorously illustrated. Advocates only low-alcohol beverages: no distillation. A charming production!

Published by:

Sahayogi Press, Tripureshwar, Kathmandu / Nepal

INFORMATION AVAILABLE ON APPROPRIATE TECHNOLOGY

FUEL GAS FROM COWDUNG, B.R. Saubolle and A. Bachmann

An excellent, succinct, clear exposure in simple language of the principles of methane production from animal dung - abundant, clear diagrams with measurements in metric and British systems. This booklet has already gained worldwide distribution and has proved very practical and helpful in several developing countries. It has received much praise.

BEEKEEPING, B.R. Saubolle and A. Bachmann

An introduction to modern beekeeping in Nepal. Written expressly for the *Apis indica*, this booklet will render great service all over South-East Asia. Clear, to the point, practical. Treats also of wall and log hives and of the African Top-Bar Hive. A treasure!

MULTI-PURPOSE POWER-UNIT (MPPU)
WITH HORIZONTAL WATER TURBINE

Basic Information, by A.M. Nakarmi and A. Bachmann

With a few words and with many diagrams and photographs one of the latest developments in the field of micro hydro-power in Nepal is explained. The modular design is made in standard sizes and manufactured in portable loads, and the system based on century-old experiences of grinding technology. The booklet provides valuable information for people interested in the production of small scale, alternative and renewable energy resources in rural areas. A real new concept!

SMALL SCALE RENEWABLE ENERGY RESOURCES
AND LOCALLY - FEASIBLE TECHNOLOGY IN NEPAL

by A. Bachmann and G.R. Shakya

This booklet provides a collection of the recent achievements in the field of Appropriate Technology and also some of the traditional technology in Nepal. The combination of the booklet, that of the article, the photographs and the directory will prove to be a useful tool for people actively involved in improvement of rural living. A good pathfinder!

Published by:

Sahayogi Press, Tripureshwar, Kathmandu / Nepal

 THE IRON "GHATTA" (BOOK REPORT)

Village water mills ("ghatta") are a very common sight in Nepal's hinterland. Using technology that is almost as old as Himalayan settlements, ghattas number about thirty thousand all over Nepal, although no exact count has ever been made. The need for manual labour for agricultural processing tasks such as dehulling and grinding cereal grain has been innovately met by traditional technology. The "dhiki" is one example which is very widespread in the hills as well as the Terai. Operated by foot, it is used for domestic dehulling as well as grinding. In other places, the "janto" is used to grain wheat, corn or pulses between two stones one of which is turned by hand. It is a small but ingenious step from the "janto" to the "ghatta".

Instead of manual turning of the grind stone, the power is derived from horizontal paddles that are turned by river water channelised and made to fall through a narrow chute. Traditional water mills are owned by local millers, by families or the community which owns the water rights of the stream on which the mill depends for water.

Although the traditional mill is a clever idea there are a lot of things in it that can be improved. First is the efficiency. A lot of power is lost in friction, and the shape of the wooden paddles do not make optimum use of the water flow.

Now comes the news of the development in Nepal of an improved "ghatta" that is more efficient than traditional ones, and the increased efficiency is cleverly used to run various other machines besides the original chore of grinding and dehulling. Designed and produced in Nepal, the multi-purpose power-unit (MPPU) as it is called, has already been installed at various sites all over Nepal, as well as being exported to Bhutan and India. The advantages of it are obvious. It is a low-cost solution to rural power, it can operate tucked away in remote parts of Nepal run and maintained by local people because it is, after all, an indigenous technology. The costs seem to be reasonable and it can be dismantled into easily portable loads. The success of the "iron ghatta", as it is affectionately called by villagers, can easily be estimated from the immense popularity of MPPU'S currently in operation.

The book, besides being an introduction to the multi-purpose power-unit can also be used as a field manual for its installation, operation and maintenance. Complete with photographs of MPPU sites and excellent technical drawings, the book explores a wide combination of the uses that the improved water mill can be put to. The authors deserve our appreciation not only for an excellent booklet, but also for their perserverence in designing, constructing and promoting this brilliant new concept for rural power that is truly appropriate! The only thing that remains to be done is to ensure that improved mills improve the lot of the Nepali villagers that it is meant to serve, and not just the already comparatively well-off mill owners.

M P P U
MULTI - PURPOSE POWER UNIT
WITH HORIZONTAL WATER TURBINE

SECOND EDITION

BY

A.M. NAKARMI AND A. BACHMANN

This booklet explains in a few words, but with many diagrams and photographs, one of the latest developments in the field of micro hydro-power in Nepal.

In essence it is based on traditional technology and can provide from two to five or ten or even more horse power.

The modular design comes in standard sizes than are manufactured in porterable loads, so that it can be easily transported even to remote areas.

This device has aroused considerable interest in many places. The booklet provides useful information in the utilization of alternative and renewable energy resources in rural areas.

Printed in Nepal
at Sahayogi Press, Tripureshwar, Kathmandu