

NONDESTRUCTIVE EVALUATION

Nondestructive evaluation (*NDE*) is a term widely used since the early 1980s. It refers to integrity evaluation of structures or quality evaluation of materials without damaging or destroying them. There are two similar terms that have a longer history: nondestructive inspection (*NDI*) and nondestructive testing (*NDT*). In the term *NDE*, the “evaluation” expresses the recent idea that quantitative measurements on flaws make it possible to evaluate the integrity of structures by fracture mechanics (1). Naturally, the technologies developed in *NDI* and *NDT* have contributed to the emergence of *NDE*, so that *NDE* technology may be taken to include both *NDI* and *NDT*.

Among the various probes available for *NDE* measurements, ultrasonic waves are most convenient for many applications. This is because they can be inexpensively generated and detected, and because they can propagate deeply into opaque materials without much attenuation and return to the surface with sufficient information on defects and properties.

On the other hand, it is known that ultrasonic or acoustic burst waves are generated during the deformation of parts or structural components. This phenomenon is called acoustic emission (*AE*). It is due to the microscopic damage done by flaw growth. Such *AE* signals can be detected by an ultrasonic transducer or sensor and used for measurement before the structure undergoes a fracture, so that *AE* measurement technology can be included in ultrasonic *NDE* technology. Indeed, *AE* measurement has been utilized as a precursor to catastrophic failure (2). *AE* measurements and analysis can determine the location of flaws in a component. The failure-related characteristics of the flaws in a component or material can be investigated by fracture mechanics and are important for estimating the fracture resistance of materials. Fracture mechanics is well integrated into ultrasonic *NDE*.

The history of ultrasonic *NDE* can be said to date back to the early 1940s, when the first flaw detector, using the ultrasonic pulse–echo method, was invented by Firestone and Fredericks. Since then ultrasonic waves have been successfully integrated into nondestructive inspection technology. Recent progress in ultrasonic technology in the VHF and UHF ranges has led to ultrasonic (acoustic) microscopy for imaging microstructures of materials or electronic devices. Quantitative measurement systems have been developed for evaluation of mechanical properties on a microscopic scale. For *NDE* by ultrasonic technology, including *AE* measurement, flaw detection is a main application at all stages, starting with the inspection of materials such as metal plates, and ending with in-service or maintenance inspection of a variety of structures. Stage inspection of parts and structures is commonly done in the transportation and power industries, such as aerospace, automobile, shipbuilding, road construction, railroads, nuclear power plants, and geothermal power plants, among others.

Ultrasonic *NDE* technology is also applied to material characterization, which is important in both science and technology for developing new materials and evaluating properties of raw materials. Ultrasonic *NDE* technology is further applied to evaluate not only such purely mechanical properties as toughness, but also mechanical-related properties such as optomechanical, biomechanical, thermomechanical, and electromechanical properties, for application to sophisticated components of transducer or sensor devices. In order to perform ultrasonic *NDE* on a microscopic level, ultrasonic (acoustic) microscopy with high resolution has been developed for materials evaluation.

2 NONDESTRUCTIVE EVALUATION

Nowadays, ultrasonic *NDE* is applied at various stages in the life history of components, ranging from the mechanical design of structures, including choice of raw materials, to the recertification of the used parts or structures for further service. In this article the fundamentals of ultrasonic measurement, applied to *NDE* and in particular to flaw detection and material characterization, are described.

Measurement System

The measurement methods to be applied to ultrasonic *NDE* can be classified, analogously to sonar, into active and passive. An active measurement system normally includes at least an ultrasonic transducer, an electronic power generator, a signal receiver, an oscilloscope, and an electronic computer. Of the various active measurement techniques developed so far, the pulse–echo method is the most commonly used for ultrasonic measurements. In particular, both normal and oblique (angle) incident beams have been utilized in flaw detection. On the other hand, for a passive measurement system, an excitation source (power supply) is not necessary. The passive technique is mainly applied to *AE* measurements, where a high gain receiving system with a broad frequency band is employed together with nondirective ultrasonic transducer.

In this section, a basic configuration for an ultrasonic measurement system is described first, and then ultrasonic transducers, typical measurement methods, and display methods for the measured data are described successively.

Basic Configuration of Measurement System. A typical pulse–echo method for ultrasonic *NDE* is shown in Fig. 1. A short pulse of ultrasound, generally in the frequency range of 1 MHz to 20 MHz and $\sim 1 \mu\text{s}$ in width, is transmitted into the object to be inspected by an ultrasonic transducer. The transducer changes electric energy into a mechanical wave and back. It is mechanically coupled to the surface of the object by a medium such as a liquid couplant for contact measurement [Fig. 1(a)] or water for immersion measurement [Fig. 1(b)]. The ultrasonic signals reflected, or *backscattered*, at a discontinuity such as a crack in the object return to the front surface as an echo pulse to be detected by the ultrasonic transducer. The output electric signals of the transducer are fed to an oscilloscope display via an electronic receiver with broadband characteristics. Usually a part of the electrical signal is also sent to a computer system to analyze and evaluate material properties or component integrity.

Ultrasonic Transducer. The ultrasonic transducer converts electric energy into a mechanical wave or vice versa. The ultrasonic transducer is an essential element in obtaining the data for the *NDE* measurement. It transmits ultrasonic waves into the object and changes received waves into electric signals. The received signals yield characteristic information on the elastic properties along the path of the waves in the inspected object. The ultrasonic transducer should be designed to efficiently excite and detect appropriate waves for measurements on an object of a particular shape.

Wave Modes and Propagation. The important modes concerned in the ultrasonic *NDE* are a longitudinal mode, a shear mode, and guided wave modes such as a plate mode and a surface wave mode (Rayleigh wave mode), as shown in Fig. 2. For a longitudinal wave mode, the direction of material particle motion coincides with the propagation direction of the wave [Fig. 2(a)], and for a shear wave mode, the direction of material particle motion is perpendicular to the propagation direction of the wave [Fig. 2(b)]. For a plate mode, the most useful wave mode for *NDE* is the zeroth-order Lamb mode wave, which has components of particle motion both normal and parallel to the plate, as shown in Fig. 2(c) and 2(d) for the symmetrical mode and the asymmetrical mode, respectively. In the case of a Rayleigh wave mode [Fig. 2(e)], the material particles move elliptically in the surface layer of the object in such a manner that the surface rises and falls as the wave propagates. This elliptical motion decreases exponentially to zero over a depth of about one wavelength into the object.

In the ultrasonic *NDE*, an incident wave of longitudinal mode is transmitted into the object, which is inspected by means of mode conversion between two propagation media. Take the case of an longitudinal incident wave going from medium I to medium II across a liquid–solid interface as shown in Fig. 3(a) and

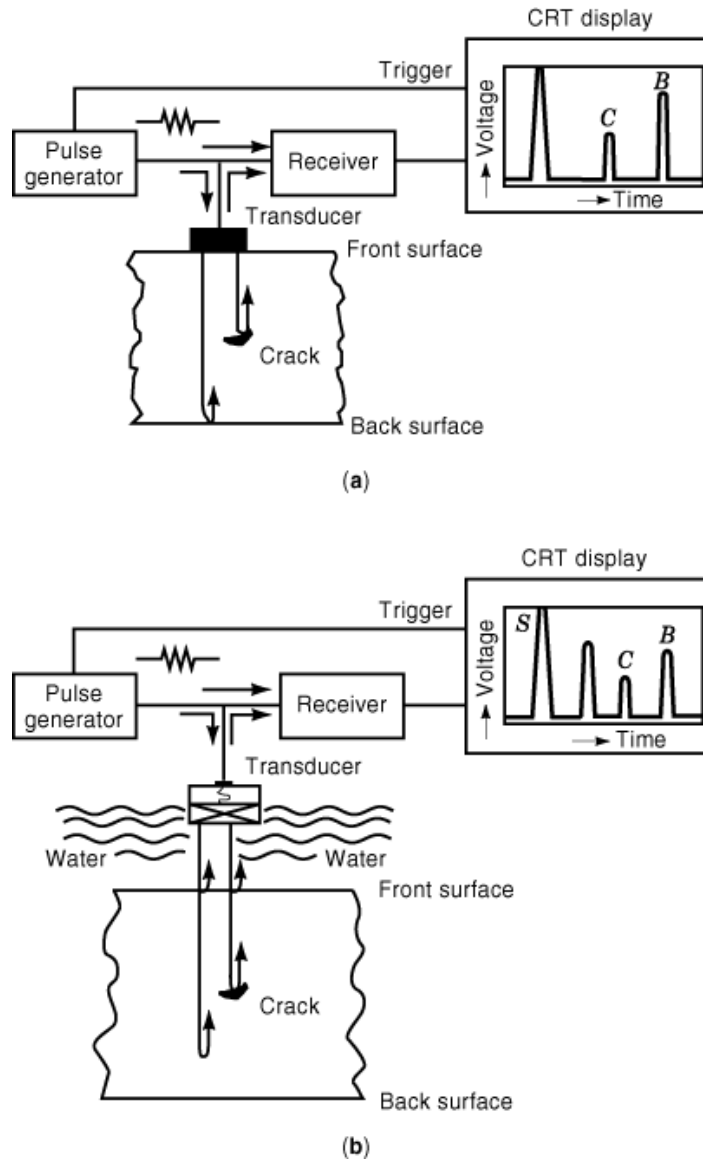

Fig. 1. The measurement methods for ultrasonic *NDE* are analogous to those for a sonar system. A pulse–echo method (pulse-reflection method) is the most common one and is in practical use in flaw detection. The measurement system is typically composed of an ultrasonic transducer, an electronic pulse generator, a signal receiver with CRT display, an electronic computer, etc. The basic configurations for two measurement methods, (a) contact and (b) immersion, are shown.

across a solid–solid interface as shown in Fig. 3(b). In the case of the liquid–solid interface, four new waves are generally created at the interface: a reflected longitudinal wave, longitudinal and shear waves propagating into medium II, and a Rayleigh wave propagating along the surface of medium II. In the case of the solid–solid interface, five new waves are generally created at the interface: those already mentioned, plus a reflected shear

4 NONDESTRUCTIVE EVALUATION

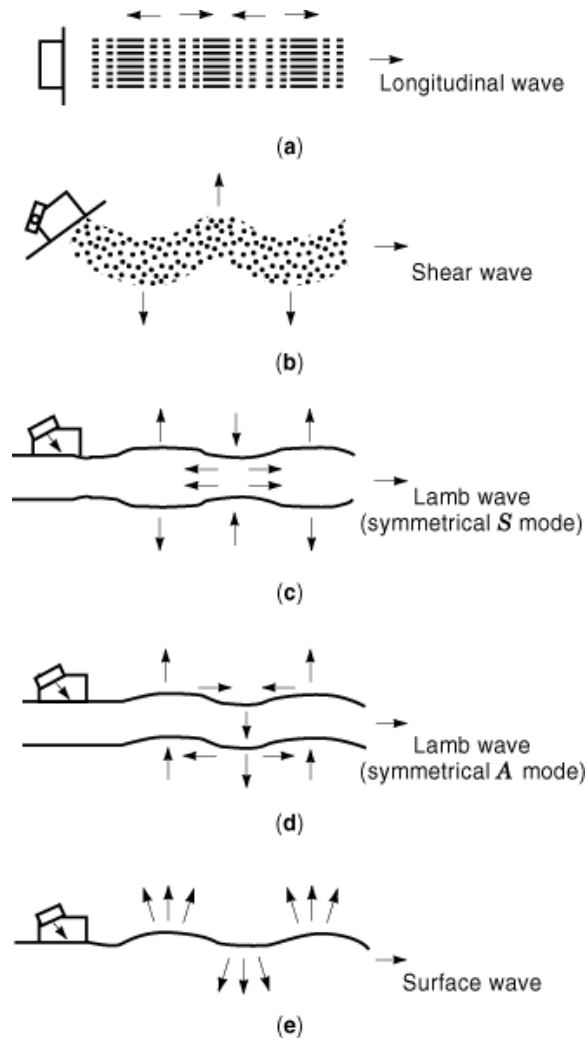

Fig. 2. The important modes concerned in the ultrasonic *NDE* are a longitudinal mode, a shear mode, and guided wave modes such as a plate mode (Lamb wave mode) and a surface wave mode (Rayleigh wave mode). (a) Longitudinal wave mode: the direction of material particle motion coincides with the propagation direction of the wave. (b) Shear wave mode: the direction of material particle motion is perpendicular to the propagation direction of the wave. (c) Symmetrical and (d) asymmetrical Lamb wave of the zeroth-order mode, both of which have components of particle motion normal as well as parallel to the plate. (e) Rayleigh wave mode: the material particles move elliptically in the surface layer of the object in such a manner that the surface rises and falls as the wave propagates along the surface.

wave. Each of these waves in medium II will propagate at an angle given by Snell's law,

$$\frac{\sin \theta_{t,s}}{v_{t,s}} = \frac{\sin \theta_i}{v_i}$$

where θ is the angle with respect to the normal, v is the wave velocity, and the subscript i refers to the wave in medium I, and the subscripts t and s refer to the longitudinal and shear waves in medium II. When medium

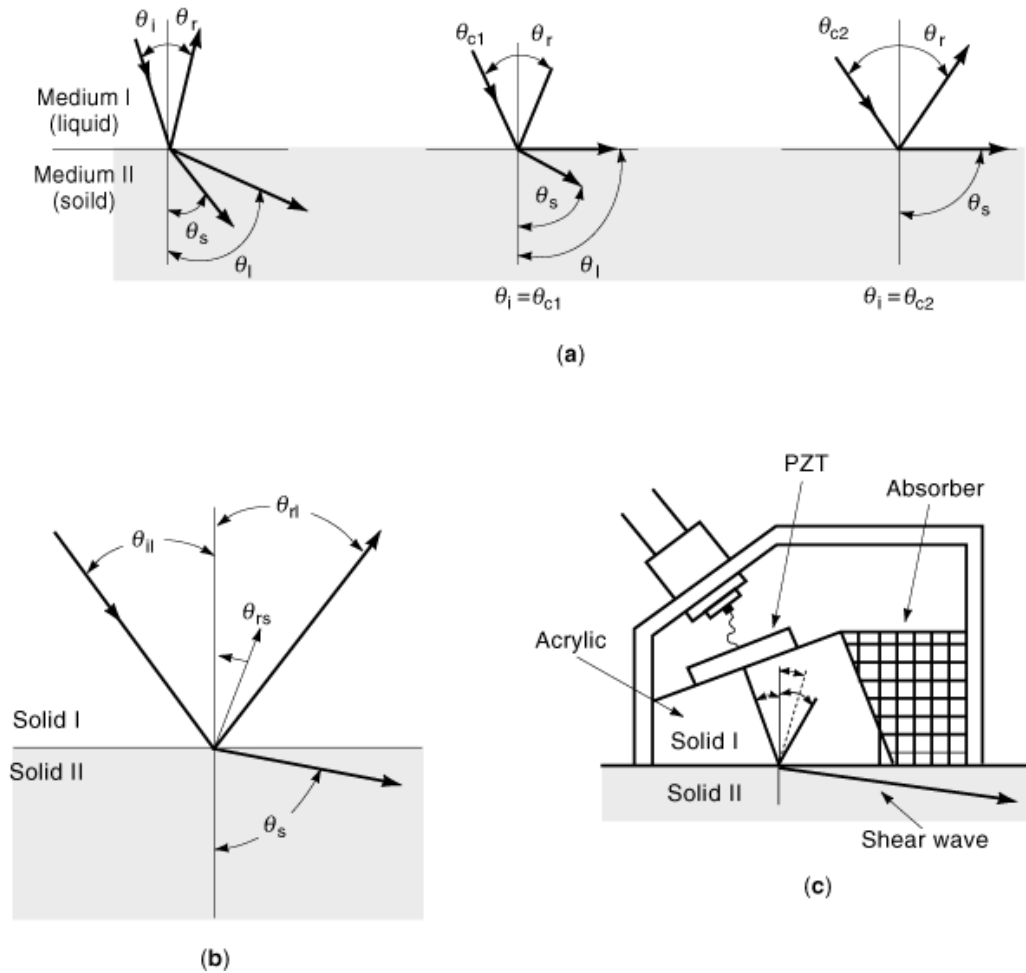

Fig. 3. In the case of oblique incidence of a longitudinal wave, mode conversion occurs at the interface of two media. Shear waves as well as guided waves are important modes in ultrasonic *NDE*, especially for flaw detection. (a) Incident and refracted beams for a liquid–solid interface. By the incidence of a longitudinal wave, a shear wave transmitting into medium II and a Rayleigh wave propagating along the surface of medium II are in general created, in addition to reflected and transmitted longitudinal waves. (b) The case of a solid–solid interface, where a reflected shear wave is added. (c) The cross section of an angle beam transducer for transmitting shear waves or guided waves, such as Rayleigh and Lamb waves, relying on mode conversion. The incident angle of the longitudinal beam is chosen to transmit only shear waves or to excite guided waves in the object.

If medium I is a liquid, only a longitudinal wave is transmitted into medium II at normal incidence. If the incident angle θ_i exceeds the first critical angle $\theta_{c1} = \sin^{-1}(v_i/v_t)$, only a mode-converted shear wave is refracted into medium II until θ_i attains the second critical angle $\theta_{c2} = \sin^{-1}(v_i/v_s)$. When the angle θ_i becomes $\theta_i = \theta_{c3} = \sin^{-1}(v_i/v_R)$, where v_R is the Rayleigh wave velocity, only a mode-converted surface wave is excited on the surface of medium II. These relations can be deduced from the phase-matching condition. In flaw detection, it is preferable to use shear waves that travel in the object without undergoing mode conversion by reflection at the boundaries or walls.

6 NONDESTRUCTIVE EVALUATION

Piezoelectric Transducers. A conventional transducer employed for *NDE* is made of a piezoelectric plate, such as PZT or LiNbO_3 , with thickness mode vibration for longitudinal waves. To transmit a suitable ultrasonic mode effectively, typically two methods are employed, namely, normal incidence and oblique incidence. An example of normal incidence of a longitudinal wave into the object has already been shown in Fig. 1. The alternative method of oblique incidence is very important for generating shear waves or guided waves in the objects.

For contact measurement, special coupling units for refraction are used in front of a longitudinal piezoelectric plate, such as a wedge to adjust the incident angle at the inspected object for mode conversion from longitudinal to shear or surface waves. Fig. 3(c) shows the cross section of such an angle beam transducer. Various types of angle beam transducers (probes) are commercially available. A lens is also used as a front member for focusing longitudinal waves to thin beams in the solid objects. A plano-concave plastic lens accomplishes focusing from a piezoelectric plate transducer into water for immersion measurements.

Frequencies for ultrasonic *NDE* range from several tens of kilohertz to several tens of megahertz, depending on the resolution desired. For ultrasonic microscopes, a frequency of several gigahertz has been attained with a thin piezoelectric ZnO film to image microstructures such as integrated circuits at a high (submicrometer) resolution.

Noncontact Transducers. Several different types of transducers have been developed for special uses. Recently electromagnetic ultrasonic (acoustic) transducers (EMATs) have been utilized for *NDE* measurements on electrically conducting materials (1). The operation of the EMAT is based on Lorentz forces generated by the interaction of eddy currents induced within skin depth of a conducting object with a static external magnetic field. Both longitudinal and shear wave ultrasonic signals can be generated and detected in this noncontact manner. The generated ultrasonic wave is a function of the coil geometry and the orientation of the applied magnetic field. The advantage of this technique is noncontact operation without the requirement of liquid coupling, which makes it applicable for tests at high temperature as well as on moving targets. The conversion efficiency of the EMAT is poor compared to that of piezoelectric transducers, but its advantages recommend it for special applications.

Optical techniques are available for generation or detection of ultrasonic waves. Traveling surface waves can be generated by means of laser beam irradiation that is intensity-modulated by ultrasonic signals on the surface of the object. On the other hand, the backscattered laser beam from a surface where surface acoustic waves (SAWs) are traveling yields information on the ultrasonic signals. For this purpose, the amplitudes and velocities of the traveling SAWs are measured by a Doppler laser detector (3).

Measurement Methods. There are three broad types of measurement methods for ultrasonic *NDE* (4). They are called through-transmission, pulse-echo and continuous wave resonance methods, as shown in Fig. 4(a), (b, b'), and 4(c), respectively, for normal incidence of longitudinal modes into the object. In Fig. 4, the sending transducer *S* and receiving transducer *R* are ultrasonically coupled to the object surface directly by a thin liquid couplant. The same measurement methods are used for the angle beam incidence method for shear wave or surface wave propagation. If an object is immersed in a liquid tank, ultrasonic beams can be injected into the object without attaching a transducer directly to it, so that the beams can easily be moved mechanically to scan the object in order to obtain data for two-dimensional images.

Through-Transmission Method. In this method, a receiving transducer *R* is attached on the back surface of the test object at a position directly opposite and parallel to the sending transducer *S*, as shown in Fig. 4(a). In an immersion measurement, both sending and receiving transducers *S* and *R* are set at a fixed distance, and the inspected object is inserted in the path of the ultrasonic beam as shown in Fig. 5(a). In this case, it is important that the active faces of the two transducers be kept parallel to each other. On the other hand, if the material sample faces are not perpendicular to the incident ultrasonic beam, refraction will require that the receiving transducer face be offset relative to the transmitted beam. In order to improve the resolution, a pair of focusing transducers are arranged at a confocal position as shown in Fig. 5(b). In this method, both continuous and pulse waves are used to detect defects in the object. As a crack *C* interrupts the traveling waves,

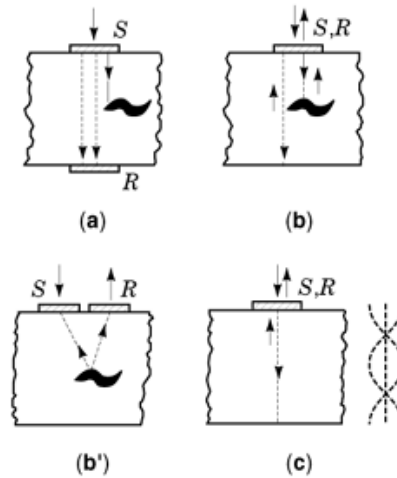

Fig. 4. Measurement methods in ultrasonic *NDE* are of three types: (a) through-transmission method, (b, b') pulse-echo (single transducer type and pitch-and-catch type, respectively), and (c) resonance.

the intensity of the received signal decreases. If a pulsed-wave is used, wave velocities or the sample thickness for a bulk material can be measured. This method can be applied to rather highly attenuating materials. It is also applied in the computer tomography method to image the cross sections of test objects.

For defects near the surface, it is effective to use Rayleigh waves that propagate along the sample surface. For surface wave measurements, sending and receiving transducers with oblique incident angle θ_{c3} are used to excite and detect surface waves on the front surface of the test object as shown in Fig. 5(c). Precise alignment, separation, and coupling of the transducers are extremely important for reliable surface wave measurements. For the ultrasonic microscope, surface waves are used to investigate the surface of test object, which can be characterized in the through-transmission method, whereas a single focusing transducer with a large aperture is typically used to generate and receive the surface waves in the immersion method. This configuration is also applied to excite and detect guided waves in a platelike object.

Pulse-Echo Method. As described above, the pulse-echo method is useful and prevalent in ultrasonic *NDE*. In the pulse-echo method, two types of configurations are employed as shown in (Fig. 4b, b'). In Fig. 4(b), a single transducer is used for both generation and detection, while in Fig. 4b') a pair of transducers compose a pitch-and-catch configuration for generation and detection. This method is also applied in the angle beam incidence method to detect flaws in a steel plate or to test the quality of a welded joint between wide steel sheets in manufacturing plants, as will be described in the later section on applications.

Continuous Wave Resonance. Figure 4(c) shows a configuration for the continuous wave resonance method. In this technique a variable-frequency oscillator is used to drive a piezoelectric transducer to generate a continuous ultrasonic wave in the test object. The resonance frequency of the thickness mode is given by the following equation:

$$f = (2n - 1)v/2t, \quad t = (2n - 1)\lambda/2$$

where f is a resonance frequency, t is the thickness, v is the velocity in the object, λ is the wavelength, and n is an integer. When the oscillator frequency reaches a value such that an odd number of half wavelengths of ultrasound coincides with the test object thickness in the direction of propagation, a mechanical resonance vibration occurs. The thickness of the test object can then be obtained from the above equation. The usual means

8 NONDESTRUCTIVE EVALUATION

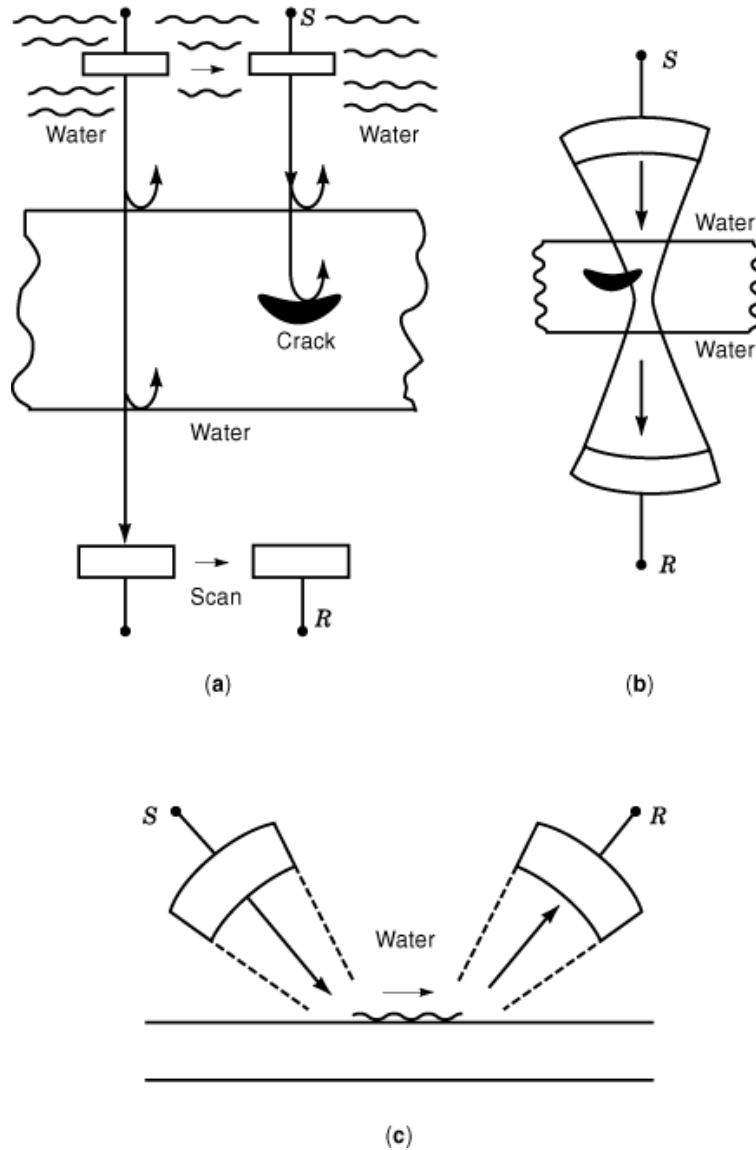

Fig. 5. If an object is immersed in a liquid tank, ultrasonic beams can be moved easily to scan the object to obtain the data for two-dimensional images. Typical configurations of immersion measurements are (a) parallel arrangement of a pair of flat transducers, (b) confocal arrangement of a pair of focusing transducers, and (c) a pair of focusing transducers arranged for oblique incidence to excite and detect surface waves or guided waves.

of detecting this resonance condition is by electronically monitoring changes in the electric power supplied to the oscillator. Resonance testing has been primarily used to measure either the thickness of an object whose wave velocity is known or the wave velocity in an object whose thickness is known. It is also used to detect laminar flaws and ply separations.

AE Measurement. *AE* measurement is a passive system which is often compared to the stethoscope of medical examination. In this system, an electronic power supply is not used. In a typical *AE* system, a piezoelec-

tric transducer is used as the *AE* sensor, and its frequency range is between 100 kHz and a few megahertz. For signal measurement, the sensor is mounted at a suitable point on the test structure; the signals received are then amplified and fed through a filter that screens out unwanted low-frequency background noise. The data acquisition system and signal processing system are almost the same as in an active ultrasonic measurement system. As *AE* signals are unpredictable, one must monitor the stem continuously, and a multisensor system must be employed to locate the emission source.

Display Methods. The display methods can be classified into A-scan, B-scan, C-scan, and computerized imaging. The first three methods are often called A-scope, B-scope, and C-scope in field service of *NDT*, or A-mode, B-mode, and C-mode in the medical community for diagnostic equipment. Ultrasonic *NDE* systems are basically combinations of these display methods with the measurement methods described in the previous section. The flaw distribution in the test object can be imaged as a two-dimensional picture on an electronic display device such as an oscilloscope, liquid crystal display panel, or $x - y$ recorder.

A-Scan. An A-scan display was shown in Fig. 1 as pulse-echo patterns along the time axis in a CRT display. In this case, a transducer is located at a point over the test object to inject ultrasonic waves normally from a definite area of the surface into the object. In the echo pattern, the voltage amplitudes of the ultrasonic pulses generated (*S*) and echoes from a crack (*C*) and the back surface (*B*) are shown as a function of time. If the ultrasonic wave velocity is known, the object thickness or distance from the transducer surface to the crack can be determined by the relation $d = vT/2$, where v is the velocity and T is the measured pulse travel time. The amplitude of the echo *C* relative to that of echo *B* gives information on the size of the projection of the crack normal to the transducer. One should choose a direction of the beam normal to the flaw surface to obtain effective reflection.

B-Scan. In a B-scan the transducer is scanned linearly over the front surface of the test object along the x direction as shown in Fig. 6(a). The horizontal axis of a CRT display is driven by a voltage proportional to the transducer position x . The vertical axis gives the time delay as in the A-scan. If the velocity of the ultrasonic wave in the test object is known, the time axis can be calibrated in terms of the depth below the front surface. When the beam spot is brightness-modulated according to the reflection intensity of cracks, two-dimensional gray scale images of cracks are depicted on the digital storage oscilloscope. Thus, a B-scan can be viewed as an $x - z$ slice of the object at a fixed depth y . The B-scan is used to determine the depth of a crack below the front surface and its length parallel to the front surface. In medical use, the B-scan system is common for diagnostic equipment in clinics.

C-Scan. In a C-scan the transducer is moved back and forth in the $x - y$ plane on the front surface of the test object as shown schematically in Fig. 6(b). The CRT display shows a plane view of the test object somewhat similar to a radiograph. However, unlike a radiograph, a C-scan cannot normally reveal a flaw located directly beneath a flaw of similar or larger size. This is because the acoustical impedance mismatch presented by the flaw often causes most of the incident ultrasonic energy to be reflected rather than transmitted. It is common practice to use an electronic time gate with an ultrasonic C-scan system, so that echoes will only be received from a selected depth range z in the test object. Shifts in the electronic time gate coupled with new scans for each shift permit echoes to be received from all depths in the test object. The position of the electron beam on the CRT display screen corresponds to the position of the transducer on the front surface of the test object. In order to permit convenient visual observation of the entire C-scan, a digital storage oscilloscope is also used.

Computerized Imaging. A variety of ultrasonic *NDE* techniques have been demonstrated in which computer processing is used to image the two- or three-dimensional information acquired from the interaction of the acoustical field with a surrounding medium. Included in these techniques are acoustical holography, scanning laser acoustical microscopy, ultrasonic tomography, and synthetic aperture imaging. For passive observations, such as *AE* measurements, a multisensor system with digital computer processing can be used to locate and map every emission source by triangulation.

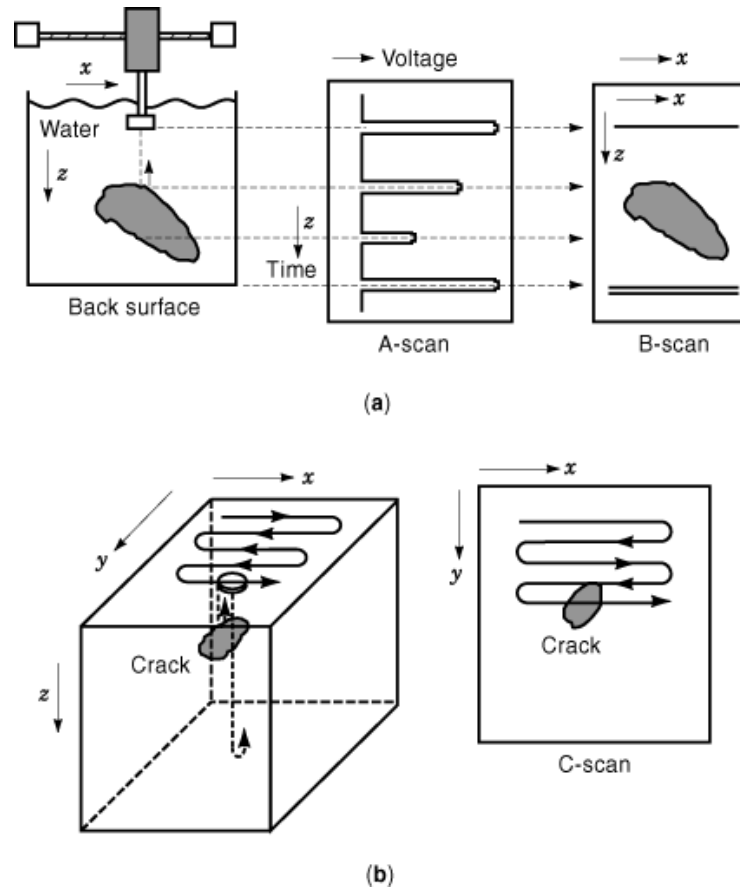

Fig. 6. Configurations of data acquisition systems to image two-dimensional distribution of defects or flaws in the objects. (a) B-scan gives an image of an x - z slice of the object, and (b) C-scan gives an image of a plane slice at a depth z .

Applications of Ultrasonic Nondestructive Evaluation

Ultrasonic *NDE* technology, including *AE* measurement, has been applied mainly to flaw detection in industry at all stages, starting with the inspection of materials such as metal plate and ending with in-service or maintenance inspection of a variety of structures. Recent progress on material science has required ultrasonic material characterization to develop new materials. In this section, several examples of flaw detection at various stages and of material characterization by ultrasonic *NDE* are described.

Flaw Detection. The discontinuity due to a flaw presents an acoustic impedance change and results in a partial reflection of an ultrasonic signal. Both the time at which the ultrasonic pulse reflected from the flaw is detected and the path traveled by the pulsed wave give information about the flaw location. The amplitude is often used as a measure of the severity of the flaw. In flaw detection, either a normal beam transducer or an angle beam transducer is used to radiate waves of desired mode into the object by either contact or immersion.

Inspection of Primary Metals. Detection of flaws in plates or sheets of metals may be performed before forming and joining them to make structural components. When a plate is rolled to a major thickness reduction, as in strip and sheet material, flaws tend to become very narrow and elongated. Inspection often samples the central region of the sheet in such a way as to detect these or other expected flaws. Plates and sheets intended

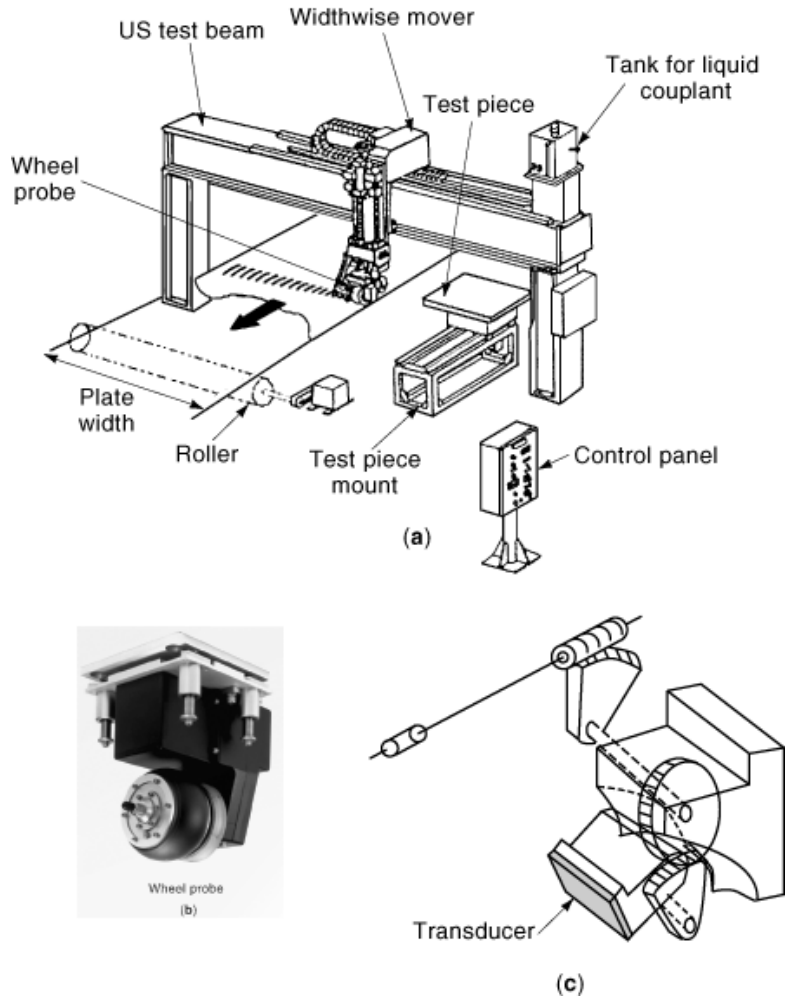

Fig. 7. An automatic flaw measurement system for wide and long plates or sheets is necessary in the production line. A wheel probe can be used to scan along the edge of the plate to obtain two-dimensional flaw maps. The wheel probe is composed of an adjustable radiation-angle transducer to excite and detect angle beams in the object through liquid couplant in the rubber tire. Either angle beam propagation measurement or Lamb mode propagation measurement can be made with this system. Part (a) shows a configuration for an automatic flaw measurement system, (b) a photograph of a wheel probe, and (c) a mechanism to adjust the incident angle of the beam in the wheel. (Courtesy of Tokimec Inc.)

to be welded in piping or tubing must have the highest quality near the edges, in the vicinity of the weld, and are inspected at highest resolution in those regions. Aluminum, for aerospace application, must often satisfy more stringent quality criteria than heavy steel plate. Normal beams, angle beams, and guided modes, in either reflection or transmission configurations, are employed, depending on the details of the problem. For a plate or sheet thickness less than the wavelength, plate mode waves can be introduced by angle beam transducers to inspect for flaws. For wide and long plates or sheets, a wheel probe in which an angle beam transducer is mounted is used to scan along the edge of the plate, so that a two-dimensional image can be obtained. Figure 7 shows a wheel probe for angle beam examination and part of an automatic measurement system for a thin sheet.

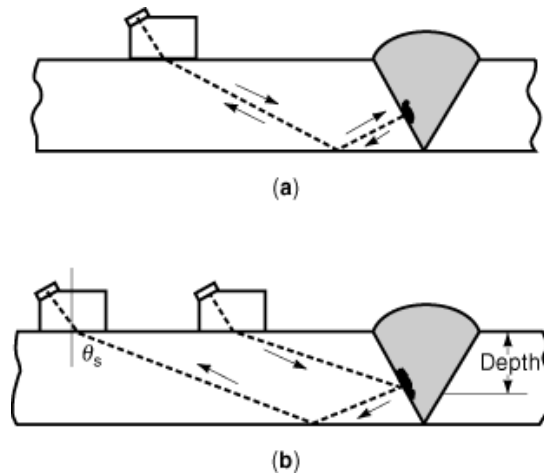

Fig. 8. Welds in products are important portions to inspect. An oblique incidence method is most useful for this purpose. Angle beam transducers are applied for the detection of weld flaws. (a) Pulse-echo measurement of a weld flaw in a plate with an angle beam transducer, and (b) pulse-echo measurement by a pair of angle beam transducers arranged in a pitch-and-catch configuration (tandem arrangement).

Inspection of Products. Semifinished or finished products are inspected by ultrasonic techniques after parts have been fabricated, but before they are placed in service. Welds are usually important portions to be inspected. As a crack produces the maximum return when it is oriented in a plane perpendicular to the beam direction, an angle beam method is suitable for application to inspect welds, whose joint surfaces tend to lie in a plane perpendicular to the plate surfaces. For this purpose, a wedge transducer is used as shown in Fig. 8(a). However, this configuration usually makes it difficult to attain the highest reflection condition with respect to the beam angle to the crack surface for the single transducer configuration. A two-transducer, pitch-and-catch configuration can detect higher reflection signals by utilizing the reflection at the bottom surface in the path of the return beam as shown in Fig. 8(b). This particular configuration is known as the tandem technique.

In-Service or Maintenance Inspection. Railroad rails are inspected periodically for safe service. Figure 9 shows an example of a system for rail flaw detection using six-transducers applied in service. There are two normal beam transducers aimed at different parts, and four angle beam transducers (two 70° transducers aimed in other directions and two 40° transducers for tandem use). Water sprayers are installed ahead of the transducers to couple ultrasound to and from the rails. A scanning speed of 45 km/h is attained in periodic maintenance of a railroad in Japan.

Reference Standards. For flaw detection, reference standards are used extensively for two distinct purposes. First, they enable the operator to check, adjust, and calibrate the test equipment periodically. For flaw detectors, instrument calibration is essential, since pulser receivers and transducers are not always manufactured to tight specification. Second, they are used as a standard against which the strengths of unknown reflectors can be compared. With the same idea, pencil lead *AE* sources are provided as reference standards as well.

Many standards have been recommended and developed to ensure the consistent, reliable, and effective application of ultrasonic *NDE*. Recent growth of global trade demands international standards. The International Standards Organization (*ISO*) has several technical committees associated with nondestructive evaluation, such as TC134. *ISO-2400* is one of the standards for calibration blocks.

Material Characterization. Research on material characterization by ultrasonic techniques deals with mechanical properties of materials associated with microstructures in a quantitative manner. Recent efforts

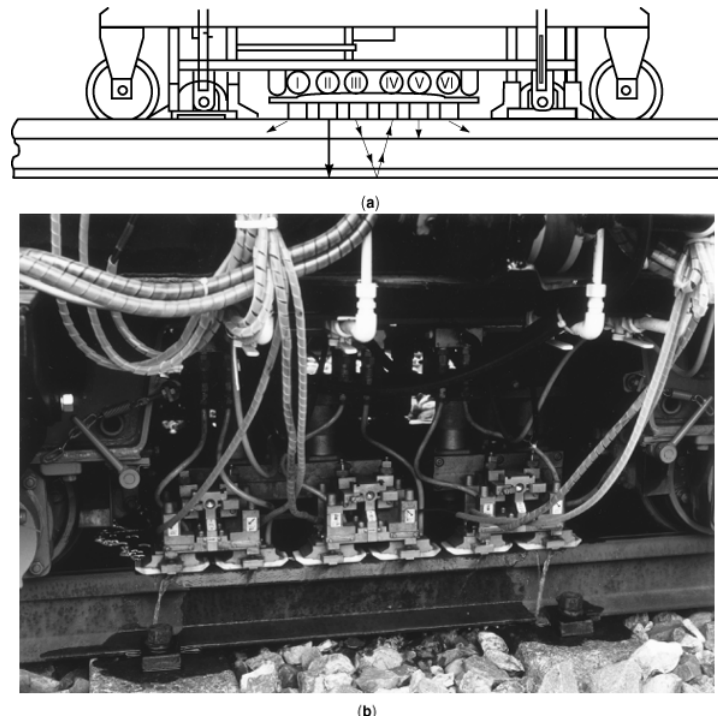

Fig. 9. Multiple transducers are installed in a frame under a flaw-detecting vehicle for rail maintenance service. (a) Configuration of the transducer array composed of two normal beam transducers and four angle beam transducers, and (b) photograph of the transducer array: six radiation shoes for ultrasonic waves are seen on the rail. (Courtesy of East Japan Railway Co.)

are directed towards the development of more sophisticated ultrasonic techniques capable of quantitative measurements on a microscopic scale—for instance, sizing and characterization of flaws to achieve lifetime prediction based on fracture mechanics. It has been shown that even a small pore ($<10\ \mu\text{m}$) in structural ceramics affects their toughness. Such a pore scatters sound waves, and analysis of backscattering provides information on these microflaws. Very high frequency ultrasonic technology has been developed to establish ultrasonic microscopy in the frequency range from 100 MHz to several gigahertz. An ultrasonic microscope provides imaging of microstructure as well as near-surface or subsurface flaws of an object. In the production line, of bonding of large scale integrated circuit tips and their mounts can be inspected with the ultrasonic microscope.

Quantitative measurements of velocities and attenuation in microscopic regions of materials are made by a line-focus-beam microscope (5). The line-focus-beam microscope has been satisfactorily applied for material evaluation to improve the production rate of the surface wave devices.

Micro-AE with frequency components above 100 MHz can be detected with the ultrasonic microscope to investigate structural materials at the microscopic level (6). Recently, nanoindentation technology has been introduced into AE measurement to evaluate the mechanical properties, including the resistance to creeping deformation, of various coating films such as TiN (7). The micro-AE method is utilized to reveal the relationship between the microstructure of materials (including very small pores) and their fracture toughness by means of analysis with fracture mechanics theory in order to develop new structural materials, especially materials used for micromachine components. (For details, see ULTRASONIC TRANSDUCERS, IMAGING).

BIBLIOGRAPHY

1. R. B. Thompson D. O. Thompson Ultrasonics in nondestructive evaluation, *Proc. IEEE*, **73**: 1716–1755, 1985. (Contains an exhaustive bibliography.)
2. K. Ono Acoustic emission, in M. J. Crocker (ed.), *Encyclopedia of Acoustics*, New York: Wiley, 1997.
3. M.-J. Kim H. Kanai, N. Chubachi Non-contact measurement of particle velocity distribution on ultrasonic waves along an elastic bar using laser Doppler velocimetry, *J. Acoust. Soc. Jpn. (E)*, **15**: 339–344, 1994.
4. E. P. Papadakis Ultrasonic instruments for nondestructive testing, in M. J. Crocker (ed.), *Encyclopedia of Acoustics*, New York: Wiley, 1997.
5. J. Kushibiki N. Chubachi Material characterization by line-focus-beam acoustic microscope, *IEEE Trans. Sonics Ultrason.*, **SU-32**: 189–212, 1985.
6. H. Kanai N. Chubachi, T. Sannomiya Non-contact measurement of acoustic emission signals in the 100 MHz frequency range using an acoustical microscope, *Acoustica*, **76**: 199–204, 1992.
7. M. Shiwa, *et al.* *J. Mater. Sci.*, **31**: 5985–5991, 1996.

NORIYOSHI CHUBACHI
Tohoku Gakuin University