

POWER TRANSMISSION LINES

Generating Stations

Although it is possible to harness the wind, tides, and solar energy to produce electrical power, these renewable energy sources represent a small portion of the total electrical energy required. Conventional power plants are still the only cost-effective means of generating large amounts of electrical power. Most electrical generating stations convert the stored natural energy of fuels into kinetic energy of a rotating shaft. The main sources of electrical energy are fossil fuel (coal, oil, and natural gas), water power (elevated water supply), and nuclear energy (uranium). There are three main types of generating stations: thermal generating stations, hydroelectric generating stations and nuclear generating stations. While thermal stations provide the bulk of the electrical energy (72%), the hydroelectric (10%) and nuclear power stations (18%) provide a good portion of electrical energy.

Thermal Generating Stations. Thermal generating stations utilize the heat released by the combustion of coal, oil, or natural gas to heat water in a boiler, which delivers steam at a high temperature (600°C) and very high pressure 30 MN/m² to a steam turbine. The mechanical energy at the turbine's shaft drives an ac generator, which converts it into electrical energy. Steam that exhausts from the turbine is directed to a condenser where it is cooled, distilled into water, and returned to the boiler. Thermal stations are usually located near large bodies of water such as rivers, lakes, and oceans, where an ample quantity of cooling water is available.

A schematic diagram of a thermal station is shown in Fig. 1(a). The fuel, in the form of crushed coal, gas, or atomized oil, is burned in the furnace. To increase combustion, fans provide a large quantity of hot air. The heat generated increases the temperature of high-purity water in the boiler, changes the water into steam, and boosts the temperature and pressure to operating levels. The hot emission gases are first passed through electrostatic precipitators before being discharged into the atmosphere via the cooling stack. The steam generated by the boiler passes through nozzles, which convert its thermal energy into kinetic energy. After the steam exits the nozzles, it passes over the rotor blades of the turbine. The exhaust steam from the turbine is moved to the water-tube condenser, which cools and condenses it. The water is then recycled to the boiler.

Oil was the most widely used fuel, until its shortage justified the use of coal. However, the harmful environmental effects of coal-fired plants diminished their use. Now the most acceptable fuel is natural gas, which reduces atmospheric pollution to a minimum, and is available in large quantities. The conversion efficiency of a thermal generating station is always low (typically ranging from 30% to 40%), because of the inherent low efficiency of the steam turbines. The maximum efficiency of any machine in which heat energy is converted to mechanical energy is given by $\eta = (T_1 - T_2)/T_2$, where T_1 is the temperature of the steam entering the turbine and T_2 is the temperature of the steam leaving the turbine. The temperature T_1 is limited by the characteristic of readily available metals to about 900 K, while the temperature T_2 is the normal ambient temperature, which is usually about 293 K. The maximum possible efficiency of the turbine is, therefore, 67%.

2 POWER TRANSMISSION LINES

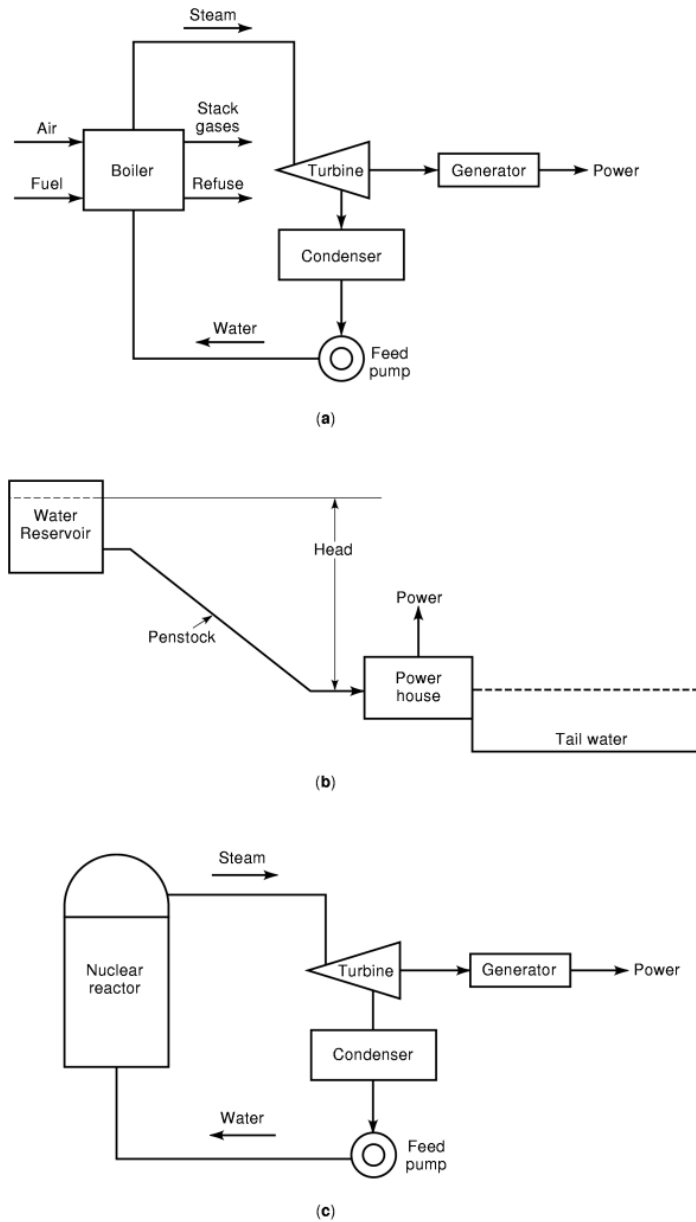

Fig. 1. Basic schematic diagram for power plants. (a) Thermal; (b) Hydroelectric; (c) Nuclear.

Hydroelectric Generating Stations. Hydroelectric generating stations convert the energy of falling water into electrical energy by means of water turbines coupled to an ac generator. The theoretical power in kilowatts that can be extracted from a waterfall is given by $P = 9.8 H Q$. Where H is the pressure head (the height of water intake above discharge level) measured in meters and Q is the flow rate of water measured in cubic meters per second. In modern hydroelectric stations, the losses in the system reduce the actual output 15% to 20% below the theoretical. The efficiency of conversion of the energy available from the water to

electrical energy is quite high (about 80% to 90%). Although a hydroelectric station has high capital costs, its running costs are very low. Also, a hydroelectric station can be started up and brought to full power within a few minutes, as compared with a thermal plant, which can take hours to deliver power.

The basic components of the hydroelectric station are shown in Fig. 1(b). It consists of the dam (water reservoir), the penstock (a means of delivering the water), the hydraulic turbine, the synchronous generator, and associated auxiliary equipment.

Hydraulic turbines are classified as reaction type or impulse type. The selection of a particular type depends on experience with the turbine at the planned speed and the lowest water pressure in the water path. Reaction turbines are preferred when the water flow rate is high (high specific speed) and the pressure head is low (<150 m). Impulse types are suited for low flow rates (low specific speed) and high pressure head (≥ 300 m).

A hydro scheme usually includes pumped storage, in which water is pumped from a lower to an upper reservoir during off-peak periods, or when the flow is more than that required for power generation. For this purpose, pumps are connected to generators, which run as synchronous motors during pumping operations. During the periods of peak load, when the main water flow is insufficient, water flows from the upper to the lower reservoir to drive the generator to produce electrical power.

Nuclear Generating Stations. Nuclear generating stations generate power from the energy released by nuclear fission of uranium and similar metals in a reactor. When the nucleus of an atom splits into two, a significant amount of energy is released. The heat energy thus released is converted to steam, which is used to rotate the steam turbine that drives the generator. Figure 1(c) shows the basic schematic diagram of a nuclear station.

The nuclear reactor is the main component of a nuclear station. It is where the fission chain reaction takes place, and where the heat is generated to be picked up by the cooling medium. The nuclear fuel elements, in the shape of rods, are placed into fuel tubes in the reactor core. The nuclear reaction takes place in the rods, and a large amount of heat is released in the process. The reaction is controlled by moving the control rods in and out of the reactor core. The control rods, made of a neutron-absorbing material, will vary the number of neutrons available to maintain the chain reaction, thereby controlling the rate of fission. The nuclear fission process is accompanied by intense radioactive radiation, requiring a special protective shielding arrangement. A coolant (water, steam, or fluid) flows through the reactor and carries off the heat from the core to generate steam. The heat generated in the core must be continuously removed, to keep the core temperature from rising too high. The coolant flows over the surface of the fuel rods, where it is heated by convection. As the coolant exits, it brings with it the heat.

Network Analysis

An electric power system consists of three major sections: (1) the generating system, (2) the transmission system, and (3) the distribution system. Electrical power is generated as three-phase alternating current at central power stations. Generation of electrical power at the same place it is utilized is not feasible, because of environmental, economic, technological, and reliability considerations. Operation of the power system also requires that proper attention be given to the safety, not only of the utility personnel, but also of the general public. Therefore, electrical power generated at one location is transmitted through an extensive system of transmission lines to the various load centers, located many miles away.

The voltage of large generators ranges from 13 · 8 to 12 kV. The generator voltage is then transformed to higher voltage levels, from 69 to 765 kV, using step-up transformers. The high-voltage network of transmission lines transmits this power over long distances to lower voltage subtransmission networks. This network transports power over shorter distances to low-voltage distribution networks. Each of these networks is coupled to the others through step-down transformers. Therefore, the power system is a complex network of

4 POWER TRANSMISSION LINES

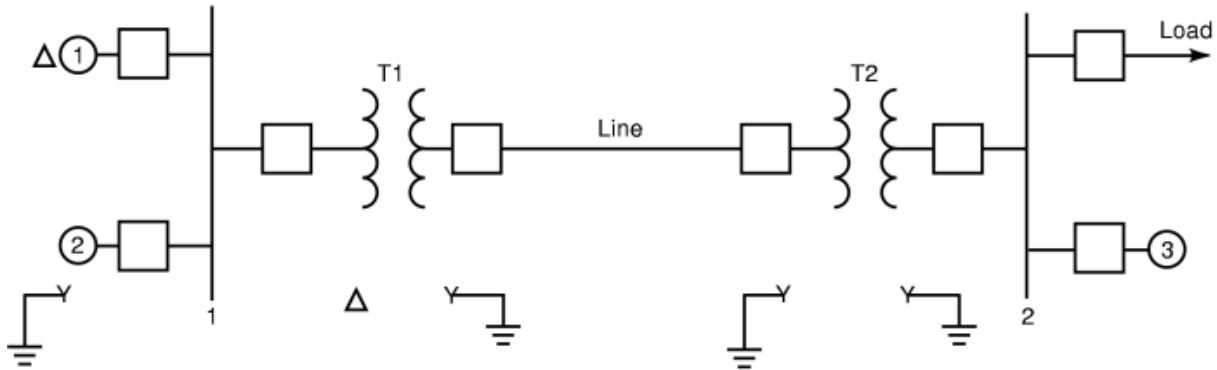

Fig. 2. One-line diagram of a simple power system.

Generators 1 and 2:	$S_G, V_G, X_G\%$
Synchronous motor 3:	$S_M, V_M, X_M\%$
Transformers T_1, T_2 :	$S_T, V_P/V_S, X_T\%$ referred to the high-voltage side
Transmission line:	$Z_1 = R_1 + jX_1$
Load:	$Z_L = R_L + jX_L$

interconnected lines. This network is responsible for transmitting power from the points of generation to the points of utilization. The significance of this function requires analysis of important network parameters under various conditions. These parameters consist of voltages, power flows, and power losses. This section discusses one-line diagrams used to simplify the representation of three-phase power systems. We then introduce determination of impedance diagrams, and finally per-unit quantities, which are used to simplify calculations for power systems, will be discussed.

The One-line Diagram. The components of a typical power system include synchronous machines, transformers, transmission lines, and static and dynamic loads. A practical three-phase system involves the interconnection between many generating stations connected to several load centers, where the power is distributed to the customers by a mesh of distribution lines and transformers. These interconnections are simply called nodes or buses. A three-line diagram can be used to represent each phase of a three-phase system. However, for large systems, it becomes impractical to show in detail all three phases of each component and their respective models in a diagram. Therefore, some simplifications have been adopted, where three-phase power systems are studied using per-phase analysis. For balanced operation, the system is represented by a diagram of a single phase, to represent all three phases. The elements are represented by standard symbols, and their interconnections are shown using a one-line diagram. Figure 2 shows a simple one-line diagram of a power system. On the diagram, ratings of the generators and transformers, reactances of the different components of the system, and information about the loads is often given.

The symbols used in one-line diagrams to represent various components vary somewhat among different electric utility companies. However, *ANSI* (American National Standards Institute) and *IEEE* (Institute of Electrical and Electronic Engineers) have standardized them. Some common symbols are shown in Fig. 3.

The complexity of representation on the one-line diagram depends primarily on the type of analysis to be performed. A comprehensive one-line diagram should include the following components and specifications:

Generators: kVA ratings, voltage ratings, % impedance and grounding methods















Symbol	Explanation	Symbol	Explanation
	Bus		Air circuit breaker
	Transmission line		Disconnect
	Static load		Fuse
	Rotating machine		Δ connection
	Two-winding power transformer		Y-connection, underground wye
	Three-winding power transformer		Y-connection, solidly grounded
	Oil circuit breaker		Y-connection, grounded through resistance
			Y-connection, grounded through inductance

Fig. 3. Symbols of some power system components.

Transformers: kVA ratings, primary and secondary voltage ratings, % impedance, connections, and grounding methods

Loads: Large motors and impedances

Conductors and Cables: Size and type

Protective devices: Fuse, relays and circuit breakers

Instrument transformers: Current and potential transformer, ratios

Relays: Types and settings

Surge arrestor and capacitors

Impedance Diagrams. Impedance diagrams are used to calculate the performance of the power system under various conditions. These diagrams, showing the impedance data of generators, transmission lines, transformers, regulators, capacitors, cables, and the like, are used for voltage drop calculations, short-circuit studies, power flow analysis, economic operation, load transfer, and unit loading calculations. It is very important that these data be updated as system condition changes.

6 POWER TRANSMISSION LINES

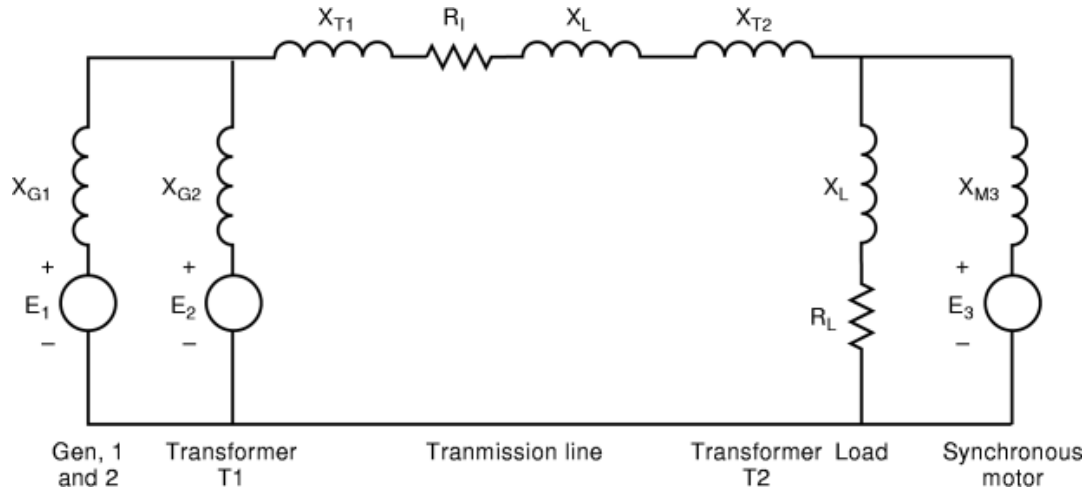

Fig. 4. Impedance diagram per phase.

The one-line diagram is used to build the impedance diagram, where the symbols are replaced by single-phase equivalent circuits of the elements. The generators, transformers, transmission lines, and electrical loads are represented by their models in the impedance diagram. The model chosen depends on the analysis to be performed. Figure 4 is an impedance diagram of the one-line diagram of Fig. 2. Transformers are represented as series impedances. Transmission lines are represented as a resistance and inductive reactance in series. Synchronous machines are replaced with voltage sources and reactances in series.

The Per-Unit System

Electric power systems can be analyzed using actual units of volts, amperes, ohms, and voltamperes. However, it is more convenient to express these quantities in terms of per unit (*pu*) or percent value of some base chosen for that quantity. The per unit system is extensively used in electrical power system calculations, where the various electrical quantities are normalized, with respect to a chosen base value.

By definition, the per unit value of any electrical quantity is the ratio of the actual value to some chosen base value of that quantity.

$$\text{Per unit value} = \frac{\text{actual value}}{\text{base value}} \quad (1)$$

Single-phase System. In an electrical network, usually four quantities are of interest: Voltage— V , current— I , impedance— Z , and apparent power— S . Generally, it is sufficient to specify the base values for any two of these quantities, then the base values for the other two can be calculated. Usually, base voltage V_{base} and base apparent power S_{base} are specified. Base current I_{base} and base impedance Z_{base} may then be calculated. When using per unit analysis, all relationships among the four quantities must be maintained.

$$I_{\text{base}} = \frac{S_{\text{base}}}{V_{\text{base}}} \quad (2)$$

$$\begin{aligned} Z_{\text{base}} &= \frac{V_{\text{base}}}{I_{\text{base}}} \\ &= \frac{(V_{\text{base}})^2}{S_{\text{base}}} \end{aligned} \quad (3)$$

The per-unit electrical quantities are calculated as follows:

$$\begin{aligned} V_{\text{pu}} &= \frac{V_{\text{actual}}}{V_{\text{base}}} \\ S_{\text{pu}} &= \frac{P_{\text{actual}} + jQ_{\text{actual}}}{S_{\text{base}}} = P_{\text{pu}} + jQ_{\text{pu}} \\ I_{\text{pu}} &= \frac{I_{\text{actual}}}{I_{\text{base}}} \\ Z_{\text{pu}} &= \frac{Z_{\text{actual}}}{Z_{\text{base}}} \end{aligned}$$

Three-phase Systems. Most power systems are composed of balanced three-phase circuits. These systems can be solved on a per-phase basis. In that case, the equations that were developed for single-phase systems can be used here as long as per-phase values are used. The direct application of Eqs. (2) and (3) to the solution of three-phase circuits requires that phase voltage (V_{phase}) and single-phase power (S_{phase}) bases be chosen.

The per unit voltage and voltamperes can be calculated as follows:

$$V_{\text{pu}} = \frac{V_{\text{actual, line}}}{\sqrt{3}(V_{\text{base, phase}})} \quad (4)$$

$$S_{\text{pu}} = \frac{S_{\text{actual } 3\Phi}}{3(S_{\text{base, } 1\Phi})} \quad (5)$$

However, it has been customary in three-phase system analysis to give data and seek results in terms of line voltages and total three-phase power. It should be noted that the denominator of Eq. (4) is the line equivalent of the base phase voltage.

$$V_{\text{base, line}} = \sqrt{3}V_{\text{base, phase}}$$

Similarly, the denominator of Eq. (5) is the three-phase equivalent of the base single-phase voltamperes.

$$3S_{\text{base, } 1\Phi} = S_{\text{base, } 3\Phi}$$

8 POWER TRANSMISSION LINES

Therefore, Eqs. (4) and (5) can be written in terms of line voltage base and three-phase power base as:

$$V_{\text{pu}} = \frac{V_{\text{actual, line}}}{V_{\text{base, line}}} \quad (6)$$

$$S_{\text{pu}} = \frac{S_{\text{actual, 3}\Phi}}{S_{\text{base, 3}\Phi}} \quad (7)$$

Although three-phase voltamperes and line voltages are used to calculate the per unit values, single-phase calculations must be used in the per unit analysis of three phase circuits.

In order for the per unit currents and per unit impedances to have the same values with the line voltages and three-phase bases as they had with the phase voltage and single-phase bases, the base current and base impedance calculated from each set of voltage and voltamperes bases must be the same. Starting with Eqs. (2) and (3), these quantities are derived for line voltage base and three-phase apparent base:

$$\begin{aligned} I_{\text{base}} &= \frac{S_{\text{base, 1}\Phi}}{V_{\text{base, phase}}} \\ &= \frac{S_{\text{base, 3}\Phi}/3}{V_{\text{base, line}}/\sqrt{3}} \\ &= \frac{S_{\text{base, 3}\Phi}}{\sqrt{3}V_{\text{base, line}}} \end{aligned} \quad (8)$$

Also,

$$\begin{aligned} Z_{\text{base}} &= \frac{V_{\text{base, phase}}}{I_{\text{base}}} \\ Z_{\text{base}} &= \frac{(V_{\text{base, phase}})^2}{S_{\text{base, phase}}} \\ &= \frac{(V_{\text{base, line}}/\sqrt{3})^2}{S_{\text{base, 3}\Phi}/3} \\ &= \frac{(V_{\text{base, line}})^2}{S_{\text{base, 3}\Phi}} \end{aligned} \quad (9)$$

The base quantities given by Eqs. (6)–(9), can be used to convert line voltages, three-phase apparent power, line currents, and per phase impedances to per unit quantities without first converting to phase voltages and single-phase values. The line values and three-phase set of bases is the most frequently used system for three-phase circuits. In fact, when a voltage and apparent power are given as bases for three-phase circuits, they are assumed to be line values and three-phase quantities, unless otherwise stated.

Changing the Base. The impedances of most power system components are usually given in per unit or percent, based on their own power and voltage rating. If these devices are incorporated in various places of a power system, the bases chosen for the power system may be different from the device's ratings. Therefore, it becomes necessary to express each device in terms of the system base values. Assume that $Z_{1\text{pu}}$ is the per-unit

impedance of a device based on its own power base S_{base1} and voltage base V_{base1} ; then, its base impedance is given by:

$$Z_{\text{base1}} = \frac{V_{\text{base1}}^2}{S_{\text{base1}}}$$

This device is used in a system where the base quantities are S_{base2} and V_{base2} . Then, its base impedance is:

$$Z_{\text{base2}} = \frac{V_{\text{base2}}^2}{S_{\text{base2}}}$$

To obtain the per-unit value of the impedance Z_1 , on the new bases, we first change the per-unit impedance on base1 to the actual value of the impedance

$$Z_{\text{actual}} = Z_{1\text{pu}} Z_{\text{base1}} = Z_{1\text{pu}} \frac{V_{\text{base1}}^2}{S_{\text{base1}}} \quad (10)$$

Next, we convert the actual value of the impedance to a per unit value on base 2,

$$Z_{2\text{pu}} = \frac{Z_{\text{actual}}}{Z_{\text{base2}}} = \frac{Z_{\text{actual}}}{V_{\text{base2}}^2 / S_{\text{base2}}} \quad (11)$$

Substituting Eq. (10) into Eq. (11), we get:

$$Z_{2\text{pu}} = Z_{1\text{pu}} \left(\frac{V_{\text{base1}}}{V_{\text{base2}}} \right)^2 \left(\frac{S_{\text{base2}}}{S_{\text{base1}}} \right) \quad (12)$$

Per-unit Impedance of Transformer. The ohmic value of the resistance and reactance of a single-phase transformer is dependent on whether it is measured on the high-voltage side or the low-voltage side of the transformer. The per-unit impedance of the transformer may be determined by choosing its apparent power rating as the base power. If impedance is measured from the low-voltage side, then the low-voltage side rating of the transformer must be used as the base voltage. Similarly, if impedance is measured from the high-voltage side, then the high-voltage side rating of the transformer is used as the base voltage. It is important to note that the per-unit impedance of a transformer has the same value, regardless of the side used for measurement.

An important advantage in making per-unit calculations is realized by the proper selection of different bases for circuits connected to each other through a transformer. The only requirement is that the voltage bases used on each side of a transformer have the same ratio as the ratio of transformation (turns ratio) of the transformer.

With such a selection of voltage bases and by choosing a common voltampere base, the per unit value of an impedance will be the same on either side of a transformer. Therefore, if voltage and voltampere bases are chosen for one part of a system, the bases are fixed for the rest of the system. When this practice is employed, the per unit impedance values calculated on different bases in different parts of the system can be collected and used on a single-impedance diagram for the whole system.

10 POWER TRANSMISSION LINES

The per unit impedance of a three-phase transformer bank is not affected by the way in which the transformers are connected. However, the relationship between the voltage bases on each side of the bank is determined by the connection.

Power Flow Analysis

Various computational methods have been developed to assist power system engineers in system planning and operational studies. These methods are used to determine:

- The magnitude and phase angle of the voltage at each bus in the system
- Flow of active and reactive power through the system
- Generating units, transmission lines, transformers, and other equipment loading
- Transformer tap settings

The type of study used to determine these quantities under normal steady-state operating conditions is called power flow (also called load flow) analysis. A load flow solution requires formulation of the network equations describing the power system. Since these equations are nonlinear, a straightforward solution is not possible. Therefore, load flow calculation often use trial-and-error iterative techniques to provide approximate solutions of the equations. At each iteration, the results converge toward the final solution. The two main techniques commonly used are the Gauss–Seidel and Newton–Raphson methods. Almost all commercial load flow computer programs are based on one or both of these methods.

Nodal Analysis and Bus Admittance Matrix. The model of the electric power system that is used in a power flow analysis consists of all the nodes (buses) in the system, the generating units and load elements connected to these buses, and the transmission lines that interconnect the buses. When the system is represented in per unit quantities, a solution can be found for the unknown parameters of that system using well-known circuit techniques.

One of the most useful methods of analysis for power systems is the application of Kirchhoff's current law to write node voltage equations. This method will be developed with reference to the simple three-bus power system network shown in Fig. 5. A generator is connected to each of the first two buses, and an electrical load is connected to the third bus. Using the system impedances, a per-phase impedance diagram for Fig. 5 can be drawn. However, using admittances is more convenient for writing nodal equations. Therefore, the equivalent node-voltage network using admittance is set up as shown in Fig. 6. This admittance diagram is basically an electrical network containing four nodes. The voltages at nodes 1, 2, and 3 can be expressed with respect to the fourth node 0, which is chosen as the reference.

Using Kirchhoff's current law, the nodal equations can now be written for the system. The sum of currents entering a node is equal to the sum of currents leaving that node through all other system elements. The current fed to node 1 from the generator at that node is

$$I_1 = (V_1 - V_2)Y_3 + (V_1 - V_3)Y_4 \quad (13)$$

The current entering node 2 from its generator is:

$$I_2 = (V_2 - V_1)Y_3 + (V_2 - V_3)Y_5 \quad (14)$$

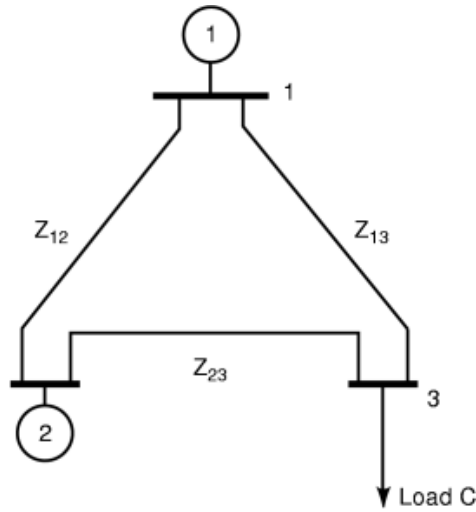

Fig. 5. A simple three-bus power system.

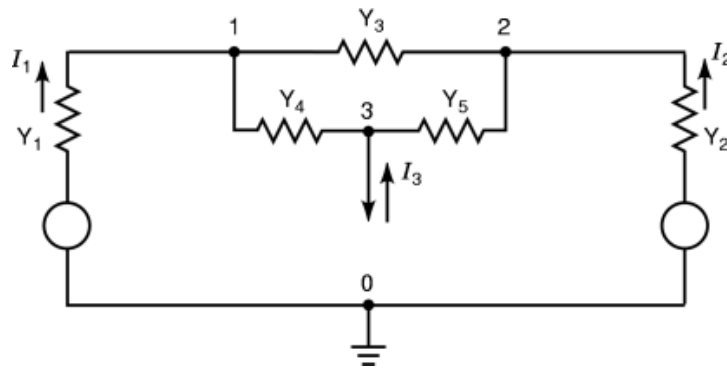

Fig. 6. Admittance diagram.

The current entering node 3 from the load at node 3 is:

$$I_3 = (V_3 - V_2)Y_5 + (V_3 - V_1)Y_4 \tag{15}$$

Since loads usually draw current from the system instead of supplying it, I_3 would be negative. V_1 , V_2 and V_3 are the voltages of nodes 1, 2, and 3, respectively, with respect to the reference node. If I_1 , I_2 and I_3 are known or can be calculated, Eqs. (13) to (15) are three independent equations with three unknowns. These equations can be solved to get the node voltages V_1 , V_2 and V_3 , from which all branch currents can be obtained. Note that the number of nodal equations required to solve a circuit is one less than the number of nodes in that circuit.

Equations (13) to (15) are rearranged to get

$$\begin{aligned} I_1 &= (Y_3 + Y_4)V_1 + (-Y_3)V_2 + (-Y_4)V_3 \\ I_2 &= (-Y_3)V_1 + (Y_3 + Y_5)V_2 + (-Y_5)V_3 \\ I_3 &= (-Y_4)V_1 + (-Y_5)V_2 + (Y_4 + Y_5)V_3 \end{aligned} \tag{16}$$

12 POWER TRANSMISSION LINES

If the following admittances are defined as

$$\begin{aligned} Y_{11} &= Y_3 + Y_4 \\ Y_{22} &= Y_3 + Y_5 \\ Y_{33} &= Y_4 + Y_5 \\ Y_{12} &= Y_{21} = -Y_3 \\ Y_{23} &= Y_{32} = -Y_5 \\ Y_{13} &= Y_{31} = -Y_4 \end{aligned}$$

Y_{11} , Y_{22} , and Y_{33} are called self-admittances at the nodes, that is, the sum of all admittances connected to that node. Y_{12} , Y_{13} , Y_{21} , Y_{23} , Y_{31} , and Y_{32} are mutual admittances at the node, that is, the negative of the sum of all admittances common to the nodes identified by their subscripts.

Then Eq. (16) is reduced to the form

$$\begin{aligned} I_1 &= Y_{11}V_1 + Y_{12}V_2 + Y_{13}V_3 \\ I_2 &= Y_{21}V_1 + Y_{22}V_2 + Y_{23}V_3 \\ I_3 &= Y_{31}V_1 + Y_{32}V_2 + Y_{33}V_3 \end{aligned} \quad (17)$$

Equation (17) can be written in the nodal-matrix equation form as follows

$$\mathbf{I}_{\text{BUS}} = \mathbf{Y}_{\text{BUS}} \mathbf{V}_{\text{BUS}} \quad (18)$$

where,

$$\begin{aligned} \mathbf{I}_{\text{BUS}} &= \begin{bmatrix} I_1 \\ I_2 \\ I_3 \end{bmatrix} \\ \mathbf{V}_{\text{BUS}} &= \begin{bmatrix} V_1 \\ V_2 \\ V_3 \end{bmatrix} \\ \mathbf{Y}_{\text{BUS}} &= \begin{bmatrix} Y_{11} & Y_{12} & Y_{13} \\ Y_{21} & Y_{22} & Y_{23} \\ Y_{31} & Y_{32} & Y_{33} \end{bmatrix} \end{aligned}$$

\mathbf{I}_{BUS} is the bus current vector, \mathbf{V}_{BUS} is the bus voltage vector, and \mathbf{Y}_{BUS} is the bus admittance matrix. The bus admittance matrix is a symmetric matrix of self- and mutual admittances.

General Form of the Power Flow Equation. One can extend Eq. (18) to a network with N buses. Where \mathbf{I}_{BUS} becomes an $N \times 1$ vector with general entry I_i , \mathbf{V}_{BUS} is an $N \times 1$ vector with general entry $V_i = V_i \angle \delta_i$ and the bus admittance matrix \mathbf{Y}_{BUS} becomes an $N \times N$ matrix. The general expression for the current injected into the i th bus is given by:

$$I_i = Y_{i1}V_1 + Y_{i2}V_2 + \cdots + Y_{ij}V_j \cdots + Y_{iN}V_N, \quad i = 1, 2, \dots, N \quad (19)$$

where

$$\begin{aligned} V_j &= \text{voltage at bus } j \\ Y_{ij} &= \text{element of the bus admittance matrix} \end{aligned}$$

Once the bus admittance matrix for a system is determined, calculation of bus voltages requires values of bus currents. In practice, the bus currents are not known directly. However, if the bus power S_i is specified, the currents can be calculated from:

$$S_i = V_i I_i^*$$

or

$$S_i^* = V_i^* I_i$$

where * denotes the complex conjugate of the quantity. The net active and reactive powers, that is, P and Q , being generated at a bus minus the P and Q of any loads at that bus, being injected into the system at bus i , is

$$S_i = P_i + jQ_i = V_i I_i^*$$

or

$$S_i^* = P_i - jQ_i = V_i^* I_i, \quad i = 1, 2, \dots, N \quad (20)$$

Solving for I_i ,

$$I_i = \frac{P_i - jQ_i}{V_i^*} \quad (21)$$

From Eq. (21) it is apparent that, if the net active and reactive powers being injected into a bus are specified, then the current is a function of the voltage at that bus. If these currents as a function of voltage are substituted in Eq. (19), the entire equation becomes a function of voltages only.

$$\frac{P_i - jQ_i}{V_i^*} = Y_{i1}V_1 + Y_{i2}V_2 + \dots + Y_{ij}V_j \dots + Y_{iN}V_N \quad (22)$$

By rearranging Eq. (22), the voltage at any bus i , where P_i and Q_i are specified, is given by

$$V_i = \frac{1}{Y_{ii}} \left[\frac{P_i - jQ_i}{V_i^*} - (Y_{i1}V_1 + Y_{i2}V_2 + \dots + Y_{ij}V_j \dots + Y_{iN}V_N) \right], \quad j \neq i \quad (23)$$

These are the static power flow equations. Although there are six variables at each bus, that is, voltage magnitude and its phase angle, current magnitude and its phase angle, and active and reactive powers, the currents have been eliminated. Also, each equation is complex, therefore, there are $2N$ real equations in all,

Table 1. Power Flow Analysis Variables

Type of Bus	V	δ	P	Q
Load	Calculated	Calculated	Known	Known
Generator	Known	Calculated	Known	Calculated
Slack	Known (1.0 pu)	Known (0°)	Calculated	Calculated

with $2N$ unknowns relating $4N$ quantities. Since these equations are nonlinear, the power flow analysis becomes the solution of sets of nonlinear algebraic equations requiring special numerical techniques.

Bus Classification. Power flow analysis involves the solution of an electric power system for the static operating conditions. The static operating state of the system is defined by the constraints on power and voltage at the network buses. As discussed in the previous section, in a power system each bus is associated with four quantities, bus voltage magnitude and its phase angle, and active and reactive powers. In a power flow analysis, two of the four quantities are specified, and the remaining two are calculated by solving the equations. Based on which quantities are specified, the buses are categorized as follows:

The Load Bus. At buses where there is no generating source, the active and reactive powers drawn by the load are specified. It is required to find the voltage magnitude and phase angle through the power flow analysis. These kinds of buses are known as load buses, or P - Q buses.

The Generator or Voltage Controlled Bus. At those buses where generating units are connected, the voltage magnitude corresponding to the generation voltage and net active power injected into the system are specified. It is required to find the reactive power generation and the phase angle of the bus voltage. These buses are called the generator or voltage-controlled buses (P - V buses). Since the reactive power generated is not known at this bus, an approximation of Q must be used in Eq. (23). Generator buses can be treated as load buses in those cases where reactive power is specified at that bus instead of a voltage magnitude.

Slack or Swing Bus. The total active power flow supplied to the system cannot be specified in advance at every bus, since the losses in the system will not be known until the power flow study is complete. Therefore, it is usual to specify one of the available generator buses as the slack or swing bus, and to consider its active power generation as the unknown. Instead, at the slack bus both the magnitude of the bus voltage V and phase angle δ are specified and all other bus voltage angles are referenced to it. The slack bus supplies or demands power to or from the system to maintain the total system power generation and consumption in balance.

The three types of buses and the status (known or calculated) of the quantities at each type of bus are summarized in Table 1. At the load buses, the active and reactive powers of the loads are specified and voltages are to be determined. At the generator buses, the active power output of the generators and the voltage magnitudes are known, therefore, the unknowns are the reactive power generated and the voltage phase angle. The phase angle of the slack bus is set to zero or any arbitrary value, so its voltage becomes the reference point for other voltages of the system. Therefore, the active and reactive powers are the unknowns at the slack bus.

Each bus is modeled by two equations, so there are $2N$ equations in all. It should be noted that it is not necessary to solve the $2N$ equations simultaneously. One can reduce the number of equations so a complete solution requires only two equations for active and reactive powers at the load buses. With V_j specified, only one equation for reactive power is required at the generator bus. Solutions for the primary unknowns V_i and δ_i at load buses and δ_i at the generator buses is therefore possible. This is followed by evaluating the secondary unknowns P_i and Q_i at the slack bus and Q_i at the generator buses, using the active and reactive equations for the slack bus and the reactive power equations for the generator buses.

Solution of Nonlinear Equations. The power flow equations are nonlinear; therefore, the solution is obtained by an iterative procedure. Two methods have gained popularity, these are the Gauss–Seidel method and the Newton–Raphson method. The Gauss–Seidel method, introduced in the late 1950s, found widespread application due to its simple procedure and relatively good performance. However, for systems with a large number of buses, it converges very slowly toward a solution and, in some cases, even fails to converge. The Newton–Raphson iterative technique was introduced to overcome the slowness of the Gauss–Seidel iterations.

The Gauss–Seidel (GS) Method of Solution. The Gauss–Seidel method uses an iterative process by specifying estimated values for the unknown bus voltages and calculating a new value for each bus voltage from the estimated values at the other buses. As each new set of voltage values becomes available, it is used to calculate still another set of bus voltages. The method is designed to progressively compute more accurate estimates of the unknown until results are obtained to any desired accuracy in a finite number of iterations.

The magnitude and angle of the voltage are specified at the slack bus. Therefore, the equation corresponding to the slack bus can be eliminated from Eq. (23). So, for an N bus system, only $N - 1$ equations must be solved to determine all the system voltages. The solution, based on expressing the voltage of a bus as a function of active and reactive power delivered to a bus, the latest computed value of the voltages at the other buses, and the admittance matrix of the nodes, will be examined.

Equation (23) is rewritten in general form to illustrate the method.

$$V_i^{c+1} = \frac{1}{Y_{ii}} \left[\frac{P_i - jQ_i}{V_i^{c*}} - \sum_{j=1}^N Y_{ij} V_j^k \right], \quad (24)$$

$j \neq i, k = c \text{ for } j > i \text{ and } k = c + 1 \text{ for } j < i$

where c represents the iteration count. The values for the voltages on the right side of the equation are the most recently calculated values (or estimated values if this is the first iteration) for the corresponding buses.

For a load bus, Eq. (24) gives a corrected value for V_i based upon scheduled P_i and Q_i when the values estimated originally are substituted. As the corrected voltage is found at each bus, it is used in calculating the corrected voltage at the next bus. The process is repeated at each bus consecutively throughout the network (except at the swing bus) to complete the first iteration. The iterative process is repeated until the difference between any two consecutive iterations is less than a prespecified tolerance ε (i.e., 0.00001 per unit). When this is possible, the solution is said to have converged.

At the generator bus, where voltage magnitude rather than injected reactive power is specified, the real and imaginary components of the voltage for each iteration are found by first computing a value for the reactive power. From Eq. (24),

$$P_i - jQ_i = \left\{ Y_{ii} V_i + \sum_{j=1}^N Y_{ij} V_j \right\} V_i^* \quad (25)$$

where $j \neq i$. If j is allowed to equal i ,

$$P_i - jQ_i = V_i^* \sum_{j=1}^N Y_{ij} V_j \quad (26)$$

16 POWER TRANSMISSION LINES

Therefore, Q_i can be evaluated from

$$Q_i = -\text{Im} \left\{ V_i^* \sum_{j=1}^N Y_{ij} V_j \right\} \quad (27)$$

where Im means the “imaginary part of” the expression in the bracket. Using this estimated value of Q_i , V_i is recalculated from Eq. (24). However, voltage V_i is reset to its specified magnitude; only the angle calculated from Eq. (24) is retained.

The Gauss–Seidel method of solution requires an excessive number of iterations before the voltage corrections are within an acceptable tolerance. The number of iterations required can be reduced somewhat by using an *accelerating factor* α , optimally a complex number, but normally chosen as real. The difference between the newly calculated voltage and the best previous voltage at the bus is multiplied by the appropriate acceleration factor, to get a better correction to be added to the prior value,

$$V_i^{c+1} - V_i^c = \alpha \Delta V_i^{c+1} \quad (28)$$

The acceleration factor for the real component of the correction can be different from that for the imaginary component. The optimum value of accelerating factor to be used exists for a given system, and a poor choice of α can result in less rapid convergence or no convergence at all. Typical values for α are in the range of 1.3 to 1.6, with 1.6 generally considered a good choice, for both the real and imaginary components.

Newton–Raphson (NR) Method of Solution. The Newton–Raphson method is an iterative procedure widely used in the power industry for solution of the load flow equations. It transforms the original set of nonlinear equations into a set of linear equations whose solutions approach the solution of the original problem. The method can be applied to a system of simultaneous equations with as many unknowns as equations.

The method employs the preliminary terms in the Taylor series expansion for a function of two or more variables. First the mathematical background of this method will be discussed and then the procedure to solve the load flow equations will be applied.

Consider the equation of a function of unknown variables (x_1, x_2, \dots, x_n) related to the specified quantities y_1, y_2, \dots, y_n , by a set of nonlinear equations:

$$\begin{aligned} y_1 &= f_1(x_1, x_2, \dots, x_n) \\ y_2 &= f_2(x_1, x_2, \dots, x_n) \\ &\vdots \\ &\vdots \\ y_n &= f_n(x_1, x_2, \dots, x_n) \end{aligned} \quad (29)$$

Assume the solutions of these equations to be $(x_1^0, x_2^0, \dots, x_n^0)$. The superscript 0 denotes that these assumed values are initial estimates. It is to be noted that the initial estimate for the equations should not be very far from the actual solution. Otherwise, the solution may diverge instead of converging and it may not be possible to arrive at a solution. One chooses some corrections $(\Delta x_1^0, \Delta x_2^0, \dots, \Delta x_n^0)$ which, when added to $(x_1^0, x_2^0, \dots, x_n^0)$, respectively, produce the next better solution.

So Eq. (29) can be written as

$$\begin{aligned}
 y_1 &= f_1(x_1^0 + \Delta x_1^0, x_2^0 + \Delta x_2^0, \dots, x_n^0 + \Delta x_n^0) \\
 y_2 &= f_2(x_1^0 + \Delta x_1^0, x_2^0 + \Delta x_2^0, \dots, x_n^0 + \Delta x_n^0) \\
 &\vdots \\
 &\vdots \\
 y_n &= f_n(x_1^0 + \Delta x_1^0, x_2^0 + \Delta x_2^0, \dots, x_n^0 + \Delta x_n^0)
 \end{aligned} \tag{30}$$

One can now solve for $(\Delta x_1^0, \Delta x_2^0, \dots, \Delta x_n^0)$ by expanding Eq. (30) as a Taylor series to get:

$$\begin{aligned}
 y_1 &= f_1(x_1^0, x_2^0, \dots, x_n^0) + \Delta x_1^0 \left. \frac{\partial f_1}{\partial x_1} \right|_{x^0} + \Delta x_2^0 \left. \frac{\partial f_1}{\partial x_2} \right|_{x^0}, \dots, \\
 &\quad + \Delta x_n^0 \left. \frac{\partial f_1}{\partial x_n} \right|_{x^0} + \dots \\
 y_2 &= f_2(x_1^0, x_2^0, \dots, x_n^0) + \Delta x_1^0 \left. \frac{\partial f_2}{\partial x_1} \right|_{x^0} + \Delta x_2^0 \left. \frac{\partial f_2}{\partial x_2} \right|_{x^0}, \dots, \\
 &\quad + \Delta x_n^0 \left. \frac{\partial f_2}{\partial x_n} \right|_{x^0} + \dots \\
 &\vdots \\
 &\vdots \\
 y_n &= f_n(x_1^0, x_2^0, \dots, x_n^0) + \Delta x_1^0 \left. \frac{\partial f_n}{\partial x_1} \right|_{x^0} + \Delta x_2^0 \left. \frac{\partial f_n}{\partial x_2} \right|_{x^0}, \dots, \\
 &\quad + \Delta x_n^0 \left. \frac{\partial f_n}{\partial x_n} \right|_{x^0} + \dots
 \end{aligned} \tag{31}$$

where the higher order of Δx^s and higher partial derivatives in the series of terms of the expansion can be neglected. The term

$$\left. \frac{\partial f_n}{\partial x_n} \right|_{x^0}$$

indicates that the partial derivative is evaluated for the values of

$$(x_1^0, x_2^0, \dots, x_n^0)$$

18 POWER TRANSMISSION LINES

If one linearizes and arranges all the Eq. (31) in matrix form,

$$\begin{bmatrix} y_1 - f_1(x_1^0, x_2^0, \dots, x_n^0) \\ y_2 - f_2(x_1^0, x_2^0, \dots, x_n^0) \\ \cdot \\ \cdot \\ y_n - f_n(x_1^0, x_2^0, \dots, x_n^0) \end{bmatrix} = \begin{bmatrix} \frac{\partial f_1}{\partial x_1} & \frac{\partial f_1}{\partial x_2}, \dots, \frac{\partial f_1}{\partial x_n} \\ \frac{\partial f_2}{\partial x_1} & \frac{\partial f_2}{\partial x_2}, \dots, \frac{\partial f_2}{\partial x_n} \\ \cdot \\ \cdot \\ \frac{\partial f_n}{\partial x_1} & \frac{\partial f_n}{\partial x_2}, \dots, \frac{\partial f_n}{\partial x_n} \end{bmatrix} \begin{bmatrix} \Delta x_1^0 \\ \Delta x_2^0 \\ \cdot \\ \cdot \\ \Delta x_n^0 \end{bmatrix} \quad (32)$$

In matrix notation

$$[K] = [J][\Delta X]$$

Here the square matrix of partial derivatives is called the *Jacobian matrix* and denoted by J . We observe that $f_1(x_1^0, x_2^0, \dots, x_n^0)$ is the computed value of y_1 for the estimated values of $(x_1^0, x_2^0, \dots, x_n^0)$. However, y_1 is not the value indicated by Eq. (29), unless the estimated values $(x_1^0, x_2^0, \dots, x_n^0)$ are accurate. If the difference between the specified value of y_n and the calculated value of y_n is designate as Δy_n^0 , one obtains

$$\begin{bmatrix} \Delta y_1^0 \\ \Delta y_2^0 \\ \cdot \\ \cdot \\ \Delta y_n^0 \end{bmatrix} = [J^0] \begin{bmatrix} \Delta x_1^0 \\ \Delta x_2^0 \\ \cdot \\ \cdot \\ \Delta x_n^0 \end{bmatrix} \quad (33)$$

Here the Jacobian matrix J^0 indicates that the initial estimates $(x_1^0, x_2^0, \dots, x_n^0)$ have been used to calculate the numerical value of the partial derivatives. By finding the inverse of the Jacobian matrix, one can solve the equations to determine $(\Delta x_1^0, \Delta x_2^0, \dots, \Delta x_n^0)$,

$$[\Delta X] = [J]^{-1}[K]$$

However, since the higher derivatives were neglected, these values added to the initial guess will not give the correct solution, and the next better solution must be obtained by assuming new estimates as follows:

$$\begin{aligned} x_1^1 &= x_1^0 + \Delta x_1^0 \\ x_2^1 &= x_2^0 + \Delta x_2^0 \\ &\cdot \\ &\cdot \\ x_n^1 &= x_n^0 + \Delta x_n^0 \end{aligned} \quad (34)$$

The better solution thus obtained is

$$(x_1^1, x_2^1, \dots, x_n^1)$$

With these values, the process is repeated until the corrections $(\Delta x_1, \Delta x_2, \dots, \Delta x_n)$ become less than ε , a preselected tolerance.

Now apply the Newton–Raphson method for solving the load flow equations. One can specify bus voltages and the elements of bus admittance matrix, in either polar or rectangular form. The polar form of the equation is most usually employed, so

$$\begin{aligned} V_i &= |V_i| \angle \delta_i \\ V_j &= |V_j| \angle \delta_j \\ Y_{ij} &= |Y_{ij}| \angle \theta_{ij} \end{aligned} \quad (35)$$

Substituting the relations of Eq. (35) into Eq. (26), one obtains

$$P_i - jQ_i = \sum_{j=1}^N |V_i V_j Y_{ij}| \angle \theta_{ij} + \delta_j - \delta_i \quad (36)$$

Separating Eq. (36) into its real and imaginary parts yields,

$$P_i = \sum_{j=1}^N |V_i V_j Y_{ij}| \cos(\theta_{ij} + \delta_j - \delta_i) \quad (37)$$

$$Q_i = - \sum_{j=1}^N |V_i V_j Y_{ij}| \sin(\theta_{ij} + \delta_j - \delta_i) \quad (38)$$

Equations (37) and (38) are solved to determine the unknown bus voltage magnitudes and phase angles. The slack bus is excluded from the solution, since both the voltage magnitude and angle are specified (1.0∠0 per unit) at the bus. For each bus i , except the slack bus, specify P and Q at all buses and estimate the voltage magnitude and angle. The specified constant values of P and Q correspond to the y constants in Eq. (32). The estimated values of voltage magnitude and angle correspond to the estimated values for x_1 and x_2 in Eq. (32). These estimated values are used to calculate values of P_i and Q_i from Eqs. (37) and (38) and to define

$$\begin{aligned} \Delta P_i &= P_{i, \text{new}} - P_{i, \text{old}} \\ \Delta Q_i &= Q_{i, \text{new}} - Q_{i, \text{old}} \end{aligned}$$

which corresponds to the Δy values of Eq. (33).

The Jacobian matrix includes the partial derivatives of P and Q , with respect to every variable given in Eqs. (37) and (38). The column matrix elements $\Delta \delta_i^0$ and $\Delta |V_i|^0$ correspond to $(\Delta x_1^0, \Delta x_2^0, \dots, \Delta x_n^0)$ and are the correction vectors to be added to the original estimates δ_i^0 and $|V_i|^0$ to obtain updated values for computing ΔP_i^1 and ΔQ_i^1 .

20 POWER TRANSMISSION LINES

Write the matrix equation for a power system with bus number 1 designated as the slack bus. Start calculations at bus 2, in matrix form:

$$\begin{bmatrix} \Delta P_2 \\ \Delta P_3 \\ \cdot \\ \Delta P_n \\ \Delta Q_2 \\ \Delta Q_3 \\ \cdot \\ \Delta Q_n \end{bmatrix} = \begin{bmatrix} \frac{\partial P_2}{\partial \delta_2} & \frac{\partial P_2}{\partial \delta_3} & \cdots & \frac{\partial P_2}{\partial \delta_n} & \cdots & \frac{\partial P_2}{\partial |V_2|} & \frac{\partial P_2}{\partial |V_3|} & \cdots & \frac{\partial P_2}{\partial |V_n|} \\ \frac{\partial P_3}{\partial \delta_2} & \frac{\partial P_3}{\partial \delta_3} & \cdots & \frac{\partial P_3}{\partial \delta_n} & \cdots & \frac{\partial P_3}{\partial |V_2|} & \frac{\partial P_3}{\partial |V_3|} & \cdots & \frac{\partial P_3}{\partial |V_n|} \\ \cdot & \cdot & \cdot & \cdot & \cdot & \cdot & \cdot & \cdot & \cdot \\ \frac{\partial P_n}{\partial \delta_2} & \frac{\partial P_n}{\partial \delta_3} & \cdots & \frac{\partial P_n}{\partial \delta_n} & \cdots & \frac{\partial P_n}{\partial |V_2|} & \frac{\partial P_n}{\partial |V_3|} & \cdots & \frac{\partial P_n}{\partial |V_n|} \\ \frac{\partial Q_2}{\partial \delta_2} & \frac{\partial Q_2}{\partial \delta_3} & \cdots & \frac{\partial Q_2}{\partial \delta_n} & \cdots & \frac{\partial Q_2}{\partial |V_2|} & \frac{\partial Q_2}{\partial |V_3|} & \cdots & \frac{\partial Q_2}{\partial |V_n|} \\ \frac{\partial Q_3}{\partial \delta_2} & \frac{\partial Q_3}{\partial \delta_3} & \cdots & \frac{\partial Q_3}{\partial \delta_n} & \cdots & \frac{\partial Q_3}{\partial |V_2|} & \frac{\partial Q_3}{\partial |V_3|} & \cdots & \frac{\partial Q_3}{\partial |V_n|} \\ \cdot & \cdot & \cdot & \cdot & \cdot & \cdot & \cdot & \cdot & \cdot \\ \frac{\partial Q_n}{\partial \delta_2} & \frac{\partial Q_n}{\partial \delta_3} & \cdots & \frac{\partial Q_n}{\partial \delta_n} & \cdots & \frac{\partial Q_n}{\partial |V_2|} & \frac{\partial Q_n}{\partial |V_3|} & \cdots & \frac{\partial Q_n}{\partial |V_n|} \end{bmatrix} \begin{bmatrix} \Delta \delta_2 \\ \Delta \delta_3 \\ \cdot \\ \Delta \delta_n \\ \Delta V_2 \\ \Delta V_3 \\ \cdot \\ \Delta V_n \end{bmatrix}$$

The superscripts that show the iteration count are excluded in Eq. (39), since they vary with each iteration. The elements of the Jacobian matrix are determined by taking the partial derivatives of the equations for P_i and Q_i and substituting in them the updated voltages from the previous iteration. In abbreviated form, Eq. (39) can be written as

$$\begin{bmatrix} \Delta P \\ \Delta Q \end{bmatrix} = \begin{bmatrix} J_{11} & J_{12} \\ J_{21} & J_{22} \end{bmatrix} \begin{bmatrix} \Delta \delta \\ \Delta V \end{bmatrix} \quad (40)$$

The Jacobian matrix has been partitioned to emphasize the different general types of partial derivatives appearing in each submatrix. For example, the off-diagonal elements of J_{11} from Eq. (37) are

$$\frac{\partial P_i}{\partial \delta_j} = -|V_i V_j Y_{ij}| \sin(\theta_{ij} + \delta_j - \delta_i), \quad j \neq i \quad (41)$$

and the diagonal elements of J_{11} are

$$\frac{\partial P_i}{\partial \delta_i} = \sum_{\substack{j=1 \\ j \neq i}}^N |V_i V_j Y_{ij}| \sin(\theta_{ij} + \delta_j - \delta_i) \quad (42)$$

In the above summation $j \neq i$, because when $j = i$, δ_i drops out of Eq. (36). Similar general forms of the partial derivatives can be determined from Eqs. (37) and (38) for calculating the diagonal and off-diagonal elements in the other submatrices.

Equation (39) is solved by inverting the Jacobian matrix. For any set of estimates of the voltage, the elements of the Jacobian matrix are evaluated and the set of equation solved for $\Delta\delta_i$ and $\Delta|V_i|$ using sparse-matrix programming techniques. These calculated values are added to the prior values of voltage magnitude and angle to acquire new values for P_i^{old} and Q_i^{old} to be used in the next iteration. The process is repeated until the precision index applied to the quantities in either column matrix is less than the specified value. For most networks, convergence is achieved in a few iterations. However, to achieve convergence the initial voltage estimates must be reasonable.

Generator buses are taken into account easily, since the bus voltage magnitudes are already known. In the Jacobian matrix, we therefore neglect the column of partial differentials with respect to the voltage magnitude of the bus. At the generator bus, the reactive power is not specified, so we neglect the row of partial differentials of Q . The value of Q at the bus can be determined after convergence by Eq. (38).

Reactive Power Flow Control

In a power system, one must not only consider the active power required by the load, but also the fact that loads consume reactive power. In addition, reactive elements are included throughout the network, which, themselves, generate or absorb reactive power in significant quantities. The VAR requirement, therefore, varies with system loading and network configuration. The flow of active power is determined by the difference in phase angle of the terminal voltages, while the flow of reactive power is determined by the difference in magnitude of terminal voltages. If a power system is to operate efficiently, some control is required, in order to realize specified voltage levels, as well as specific values of reactive power at each generator bus. Under normal operating conditions, all VAR requirements of the load can be supplied from the generators. However, in practice, this may not be within the operating capabilities of the generators, or it may not be the most economical method. Reactive power and, therefore, bus voltage magnitudes, can be controlled by the following five methods:

- (1) Generator field excitation
- (2) Shunt capacitor banks
- (3) On-load tap-changing transformers
- (4) Synchronous compensators
- (5) Static VAR compensators (SVC)

Synchronous Generators. Consider a synchronous generator supplying power to a large grid with several other generating stations. The system is so large and strong that every bus appears to be an infinite bus. That is, neither the voltage nor the frequency at the generator bus can be altered by changes in the generator's operating conditions. The single-phase equivalent circuit of the generator is shown in Fig. 7(a).

If the generator is operating at a constant speed, the induced voltage E_0 is a function of the dc excitation I_x . If the active power output is held constant while the dc excitation is varied, $V_t I \cos \theta$ must remain constant, where V_t is the voltage at the system bus. As illustrated in Fig. 7(b), if the magnitude of E_0 is changed, the magnitude of I and the phase angle θ also changes. With the phase angle θ equal to zero the generator supplies only real power to the bus. But we can see that as E_0 is increased, angle θ starts lagging, causing the generator to supply reactive power to the bus. Accordingly, an overexcited generator supplies reactive power to the bus, and an underexcited generator absorbs reactive power from the bus. Therefore, flow of reactive power between

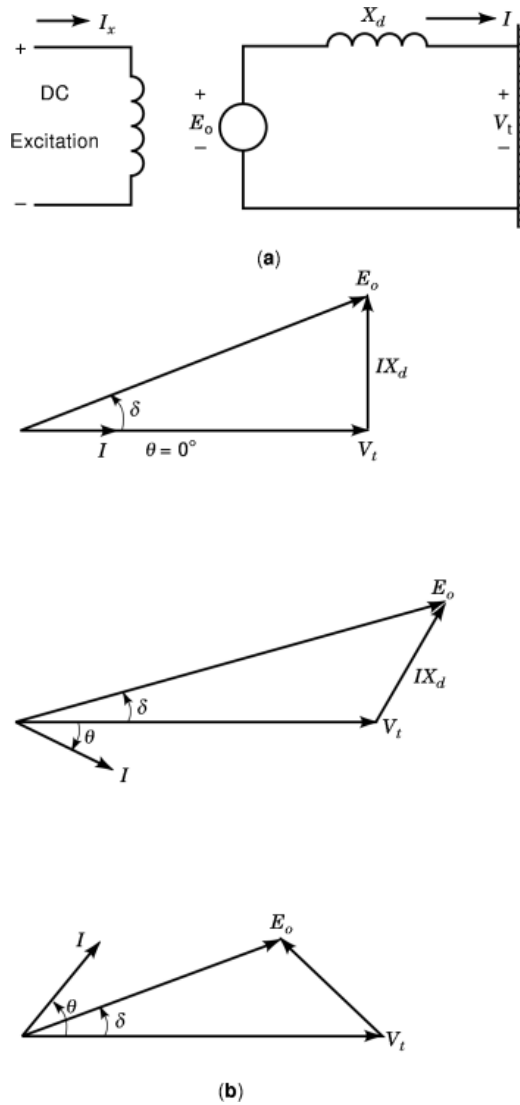

Fig. 7. Synchronous generator. (a) Equivalent circuit; (b) Phasor diagram showing the effect of varying E_o .

the generator and the system can be controlled by varying dc excitation of the generator, while maintaining a constant active power output.

Active power output of the generator is given by

$$P = \frac{V_t E_o}{X_d} \sin \delta \quad (43)$$

where, δ is the load angle between V_t and E_o .

Equation (43) shows that if V_t and E_o are held constant, the active power output is directly dependent on δ . In steady-state operation, active power output can only be increased by an increase of mechanical power input. Therefore, δ is also directly dependent on the mechanical power input.

The reactive power output is given by

$$Q = \frac{V_t}{X_d} (E_o - V_t \cos \delta) \quad (44)$$

In Eq. (44), if V_t and E_o are held constant, the reactive power will apparently be affected by changes in δ or changes in mechanical power input. However, the normal operating range for δ is quite small ($<15^\circ$). For small changes of δ , $\sin \delta$ changes significantly but $\cos \delta$ changes by only a small amount. Therefore, from Eqs. (43) and (44) one can see that an increase in δ causes a larger change in P than in Q .

In Eq. (44), with P held constant, both an increase in E_o and decrease in δ means Q will increase if already positive or decrease in magnitude and become positive if Q was negative before the field excitation was increased.

One concludes that the reactive power output of a generator can be controlled by changing the dc excitation, and the active power output can be controlled by varying the mechanical power input. By controlling the amount of active and reactive power generated at each generating station, the general power flow in the system can be controlled.

Equations (43) and (44) can be generalized for a network where bus 1 is connected to bus 2 through a reactance X . Resistance can be neglected, since in most power circuits $X \gg R$. Bus voltages are V_1 and V_2 and δ is the angle by which V_1 leads V_2 . Assuming $V_1 > V_2$, the active power transferred from bus 1 to bus 2 is

$$P = \frac{V_1 V_2}{X} \sin \delta \quad (45)$$

Similarly, the flow of reactive power from bus 1 to 2 is

$$Q = \frac{V_2}{X} (V_2 - V_1 \cos \delta) \quad (46)$$

Q is thus determined primarily by $V_1 - V_2$. The direction of reactive power flow can be reversed by making $V_2 > V_1$. Therefore, if a voltage difference exists across a largely reactive link, the reactive power flows toward the lower voltage bus. In other words, if there is a reactive power deficit at a point in an electric system, this shortage must be furnished from the rest of the network. So the voltage at that point falls. On the other hand, a surplus of reactive power generated will cause a voltage rise.

Specification of Bus Voltages. In a power flow study, it is necessary to specify voltage magnitude or reactive power at every bus except the slack bus, where voltage is specified by both magnitude and angle. At the generator bus, the voltage magnitude and active power supplied by the generator is specified. The reactive power is then determined by solving the power flow equations. Let us study the effect of the magnitude of the specified bus voltage on the value of reactive power supplied by the generator to the power system.

Figure 8(a) shows a generator represented by its equivalent circuit. The power system, including any local load on the bus, is represented by its Thévenin equivalent circuit. For a fixed power delivered by the generator, $E_{th} I \cos \theta$ must remain constant. The voltage specified at the bus is:

$$V_t = E_{th} + jIX_{th} \quad (47)$$

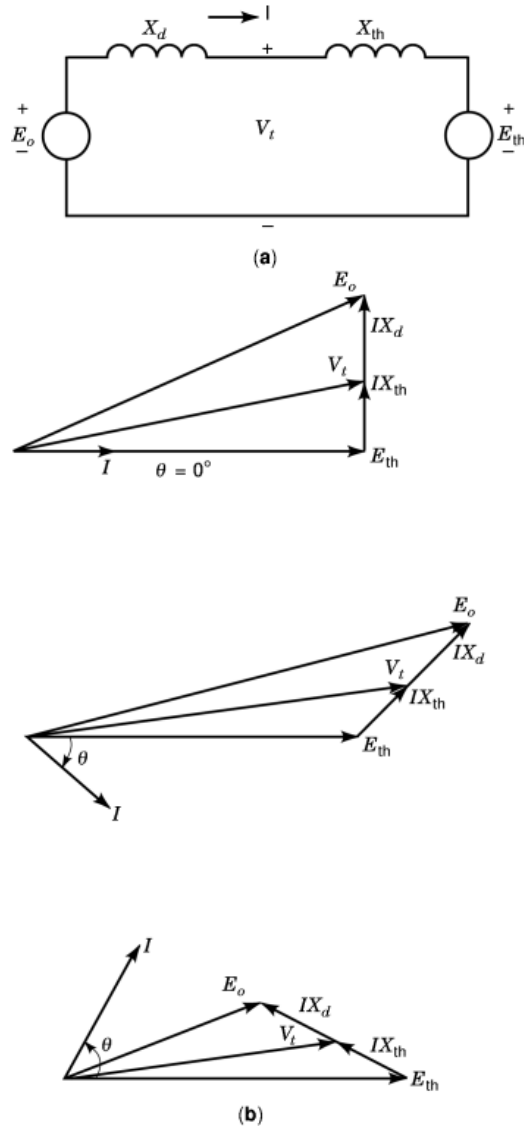

Fig. 8. Generator connected to a power system. (a) Equivalent Circuit; (b) Phasor diagrams for different values of bus voltage.

and

$$E_o = V_t + jIX_d \tag{48}$$

The phasor diagram with three different values of bus voltage is shown in Fig. 8(b). With constant power input to the bus, larger magnitudes of bus voltage V_t require a larger E_o , which is obtained by increasing the dc excitation of the generator. As shown in Fig. 8(b), increasing the bus voltage by increasing E_o causes

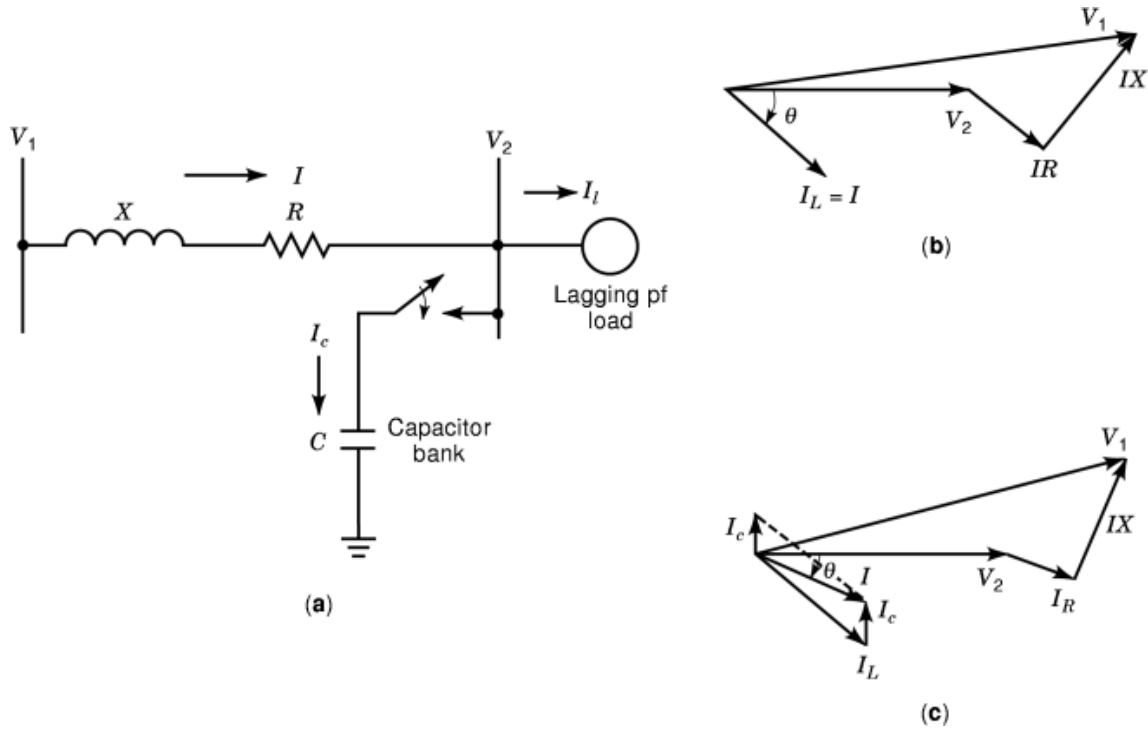

Fig. 9. A capacitor across a system. (a) Circuit diagram; (b) Phasor diagram without the capacitor; (c) Phasor diagram with the capacitor added.

the current to become more lagging. When performing a load flow study, increasing the voltage specified at a generator bus means that the generator feeding the bus will increase its reactive power output to the bus. From the viewpoint of operation of the system, by adjusting the generator excitation we are regulating the bus voltage and reactive power generation.

Shunt Capacitor Banks. Generally, the loads on a power system are inductive in nature. Reactive power must, therefore, be generated to supply these loads. For a given active power, a reactive load draws more current than a purely resistive load. Larger currents mean greater voltage drops along transmission lines and more power losses.

A method of controlling the bus voltage is by adding shunt capacitor banks at the buses at both transmission and distribution levels. Essentially capacitors are used to supply leading VARs to the system at the point where they are connected. When they are in parallel with a load having a lagging power factor, the capacitors can supply some or all of the reactive power required by the load. Thus, capacitors reduce the line current necessary to supply the load and reduce the voltage drop in the line. Since capacitors lower the reactive requirement from generators, greater active power output is available. Capacitor banks can be energized continuously, but, as regulators of voltage, they are switched on and off during load cycles. Switching may be manually or automatically controlled in response to voltage or reactive power requirements.

In performing load flow analysis, voltage magnitude can be specified only if there is a source of reactive power generation. Therefore, at load buses where there are no generators, capacitor banks must be assumed to specify the value of Q required.

Figure 9(a) shows a simple system, in which capacitors are applied at a point in the circuit supplying a lagging power factor load. The phasor diagram serves to explain the increase in voltage at the bus where

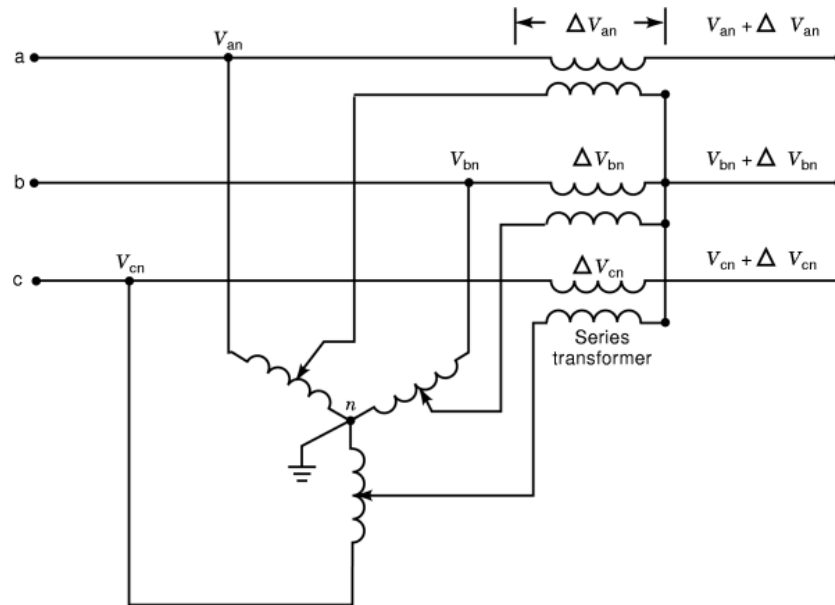

Fig. 10. Regulating transformer for control of voltage magnitude.

capacitors are installed. With the switch open, the line current I is the same as the load current I_L . Figure 9(b) shows the phasor diagram for this condition. When the switch is closed, the line current is the sum of the capacitor current I_C and the current drawn by the load. From the phasor diagram shown in Fig. 9(c), it is clear that the line current is decreased and the source voltage V_1 is reduced with the insertion of shunt capacitors. The power factor of the source is also improved. One can add proper size capacitor banks at the load, so that all the reactive power required by the load reactance is supplied by the capacitors.

Synchronous Compensators. Synchronous motors can provide continuously adjustable reactive power, in addition to their main driving duty. In industrial settings, where large synchronous motors are installed, they are normally used in this way for correcting the power factor of the load. Depending on the value of field excitation, synchronous motors absorb or generate reactive power. A synchronous compensator is a synchronous motor running without a mechanical load, which can be used anywhere in the system to generate or absorb reactive power. A synchronous compensator has the disadvantage of slower speed response, higher losses, and higher maintenance requirements. In addition, the installation cost of synchronous compensators is quite high, compared with static capacitors.

Control by Tap-Changing Transformers. Transformers, besides changing voltage from one level to another in a power system, provide an additional means of controlling the flow of both real and reactive power. Transformers that provide a small adjustment of voltage magnitude, usually $\pm 10\%$, and others that shift the phase angle of the line voltages, are important components of a power system. Some transformers regulate both the magnitude and phase angle.

The variables that control the flow of active and reactive power on a transmission line are voltage angles and voltage magnitudes, respectively. These variables can be controlled by using regulating transformers. Regulating transformers do not transform between voltage levels, but are designed for small adjustments of voltage from one side to the other. These transformers provide taps on windings to change the ratio of transformation by changing taps. A tap change tap can be made while the transformer is energized. Such transformers are called tap changing under load (*TCUL*) or load tap changing (*LTC*) transformers. The tap

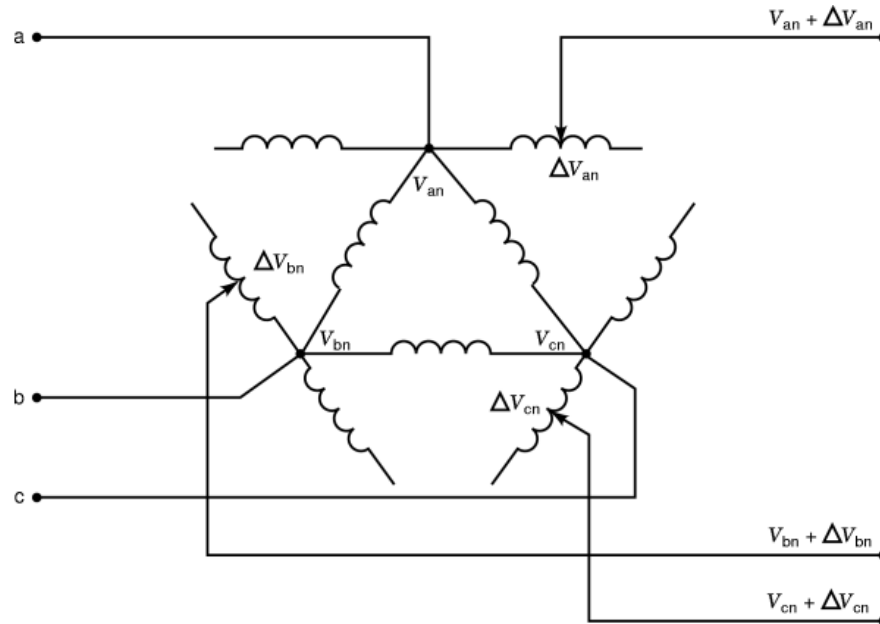

Fig. 11. Regulating transformer for control of phase angle.

changing is automatic and operated by motors that respond to relays set to hold the voltage at the prescribed level.

Figure 10 shows a regulating transformer for controlling voltage magnitude, and Fig. 11 shows a regulating transformer for phase angle control, also known as phase-shifting transformer. In the phase shifting transformer, each of the three windings to which taps are made is on the same magnetic core as the phase winding, whose voltage is 90° out of phase with the voltage from neutral to the point connected to the center of the tapped winding.

Figure 10 shows that a voltage ΔV_{an} in phase with V_{an} is tapped off the Y-connected autotransformer. This voltage is then summed to V_{an} through the transformer in the line of phase “a.” Since ΔV_{an} is in phase or 180° out of phase with V_{an} , only the magnitude of V_{an} changes. In Fig. 11, the coils at each point of the Δ are wound on a core with the Δ phase coil they parallel.

If the voltages of Fig. 11 have “abc” phase sequence, the corresponding phasor diagram is illustrated in Fig. 12. As long as ΔV_{an} is small, the voltage V_{an} is shifted in phase angle with very little change in magnitude. With these types of transformers voltage magnitudes and angles can be adjusted to help control the flow of active and reactive power on transmission lines.

Static VAR Compensator SVC. A static VAR compensator or controller combines a Thyristor Controlled Inductor (*TCI*) and a Thyristor Switched Capacitor (*TSC*). It is useful in applications requiring rapidly varying reactive power requirements to perform quick and precise control of reactive power. The leading VAR necessary for VAR compensation is supplied by connecting TSC across the ac lines. Figure 13 shows a scheme in which the capacitor banks are connected or disconnected, using SCR, to correct the load power factor. For loads with varying VAR requirements, a TCI is placed in parallel with TSC. The capacitor banks are switched in and out, to provide a fixed amount of leading VAR. Using phase control, the inductor absorbs a variable amount of lagging VAR, depending on the delay angle of the SCR. If the lagging VAR drawn by the TCI is equal to the leading VAR supplied by the capacitors, the net reactive power will be zero, and the load power factor will be unity. From this point, if the load power factor becomes lagging, the lagging VAR of the TCI

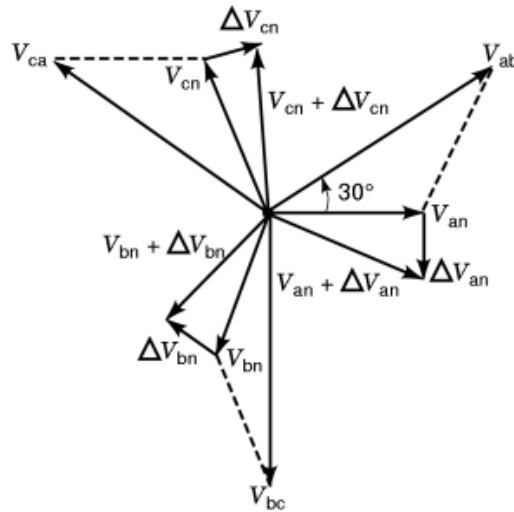

Fig. 12. Phasor diagram for phase-shifting transformer.

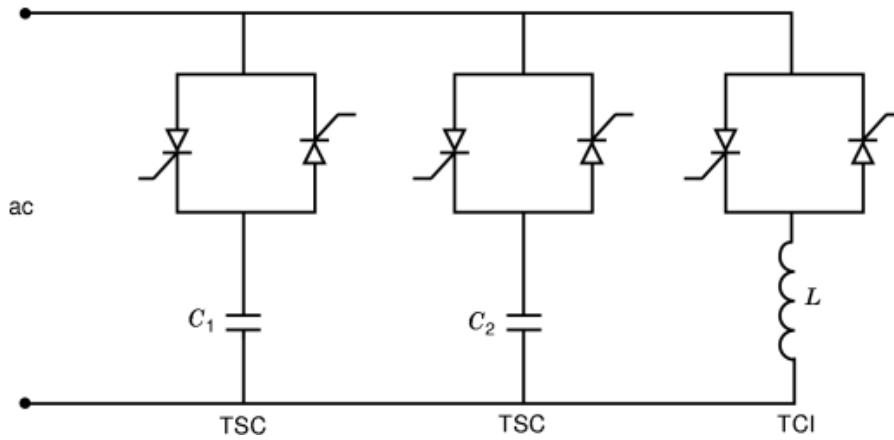

Fig. 13. Static VAR compensator.

can be decreased by adjusting the delay angle, thereby increasing the net leading VAR. If more leading VAR are required, another capacitor bank can be switched. In this way, the TSC provides leading VAR in discrete steps, while the TCI provides precise continuous control between steps. The same technique can be applied to three-phase circuits.