

## HVDC POWER TRANSMISSION

High voltage direct current (*HVDC*) power transmission is employed to move large amounts of electric power (bulk power) from one location to another in the form of direct current (*dc*) rather than alternating current (*ac*). However, the majority of bulk power in the world today is transmitted as *ac*. The current and voltage of *ac* change from positive to negative and back to positive in sinusoidal waveforms typically with frequencies of 50 or 60 times a second. Only a small percentage of the world's bulk electric power transmission is done by HVDC, and *dc* has both constant voltage and current.

Because almost all electric power is generated as *ac* and as virtually all interconnected transmission grids are *ac*, it is necessary to convert *ac* to *dc* before it can be transmitted via HVDC. After transmission, the power must be converted back to *ac* before it can be delivered to the *ac* transmission grid in the receiving system. The conversion process (*ac* to *dc* and *dc* to *ac*) for bulk power requires significant amounts of costly specialized equipment.

Some of the circumstances that require and/or merit HVDC power transmission are as follows:

- (1) If power is to be transmitted between a 50 Hz *ac* system and a 60 Hz *ac* system, it is necessary to convert the power from 50 Hz *ac* to *dc*, transmit it, and then convert it back to 60 Hz *ac*. An *ac* transmission line cannot be used because of the different frequencies.
- (2) If it is desired to exchange power between two unsynchronized *ac* transmission grids having the same frequency, economically HVDC will be the only choice. Slight differences in frequencies in the two systems would cause an *ac* interconnection to overload and trip.
- (3) Underground and submarine *ac* cables are limited in length due to capacitive charging current. Beyond a critical length (about 50 km) the charging current exceeds the cable's thermal capacity. Direct current cables have no such length limitations and therefore are used for longer distance applications. For example, an island located 240 km (150 miles) offshore could receive electric power via a *dc* submarine cable, but not an *ac* submarine cable.
- (4) HVDC transmission can be more cost effective than *ac* transmission for very long overhead lines. For a given amount of power to be transmitted, less expensive insulation, conductors, and transmission towers are needed for the overhead *dc* line than for an overhead *ac* line. Also, for long distances the *ac* overhead line may require series and/or shunt reactive compensation equipment to maintain acceptable voltage and stability performance; this is not required for the *dc* line. At some distance, these cost advantages enjoyed by the *dc* line compensate for the cost of the conversion equipment at the two ends. The line length at which the cost advantage moves from *ac* to *dc* (called the break-even distance), varies with the cost of HVDC equipment, the value of energy losses, and other economic parameters, but is generally over 800 km (500 miles).
- (5) In some circumstances the capability of HVDC to set exactly the amount and direction of power transmission at any time makes it preferable to *ac* transmission.

## 2 HVDC POWER TRANSMISSION

### History of HvdC

HVDC transmission was first used commercially in 1954 when a dc submarine cable linked Gotland Island (1) with mainland Sweden. HVDC transmission was chosen rather than building additional thermal generation on the island. That HVDC system and the ones that followed for almost two decades used mercury arc valves for converting from ac to dc and vice versa.

Starting with the Eel River (2) back-to-back converter application in 1972, mercury arc valves were replaced by thyristors in commercial HVDC applications. Thyristors are silicon-based power semiconductors and were initially known as SCRs (silicon-controlled rectifiers). Similar to diodes they allow only unidirectional current flow. However, a small current injected at the gate of a forward-biased thyristor permits control of the start of current conduction. Once the thyristor is conducting, it will cease conduction only if the voltage across the thyristor reverses and the current it is conducting drops to zero. The HVDC controls send coordinated signals to the gates of groups of thyristors so that by switching the dc current through various paths at various times, as described later, the ac-to-dc or dc-to-ac conversion process is realized.

Approximately 50 HVDC transmission projects have been built around the world since 1954. At present, at least 10 more projects are under construction or being planned. The deregulation and restructuring of the electric utility industry currently in progress may encourage more applications of HVDC transmission, perhaps for nontraditional purposes.

### Components of an HVDC Transmission System

Figure 1 illustrates the main components of a typical bipolar (one positive and one negative pole) HVDC transmission system with an overhead transmission line. The typical system would have two identical HVDC converter stations connected by a dc transmission line. This figure shows one of the two HVDC converter stations and a small part of the dc transmission line. For simplicity, the details of only the positive pole of the station are shown; the negative pole is a mirror image of the positive pole. An HVDC station is called a rectifier when it is receiving power from the ac transmission grid and transferring the power to the dc transmission line. As a rectifier, it converts ac power to dc power. The HVDC station that takes power from the dc transmission line and converts it back to ac power to flow on the ac transmission grid is called an inverter. The typical HVDC converter station can act as either a rectifier or inverter using exactly the same equipment.

Assume that the converter in Fig. 1 is a rectifier and is receiving power from a 60 Hz ac line shown in the lower left of the figure. The ac harmonic filters shown in the lower center of the figure are connected to each of the three ac phase conductors. They are tuned to pass all harmonic currents (at frequencies greater than 60 Hz) that are created by the conversion process to ground, thereby preventing them from flowing into the ac system and causing problems. Those ac filters also provide reactive power (vars), which is consumed in the conversion process.

The ac currents then pass through the ac side windings (known as the primary side windings) of the converter transformers. Currents are induced in the secondary windings of the converter transformers, which are connected in turn to the tall valve assemblies shown in the center of the figure. The valve assemblies contain multiple valves, each of which contains many individual thyristors connected in series to achieve the desired voltage and sometimes in parallel to accommodate the desired current.

Control signals to start conduction are sent simultaneously to every thyristor in a valve. Those signals are coordinated such that the resulting current to the dc line is virtually constant, except for some harmonics that must be filtered. The current leaves the valve hall via the wall bushing, is smoothed by the smoothing reactor to reduce ripple components, and then proceeds via the transmission line to the other converter station, which is acting as an inverter. The dc filter shown in the figure reduces harmonic voltages that appear on

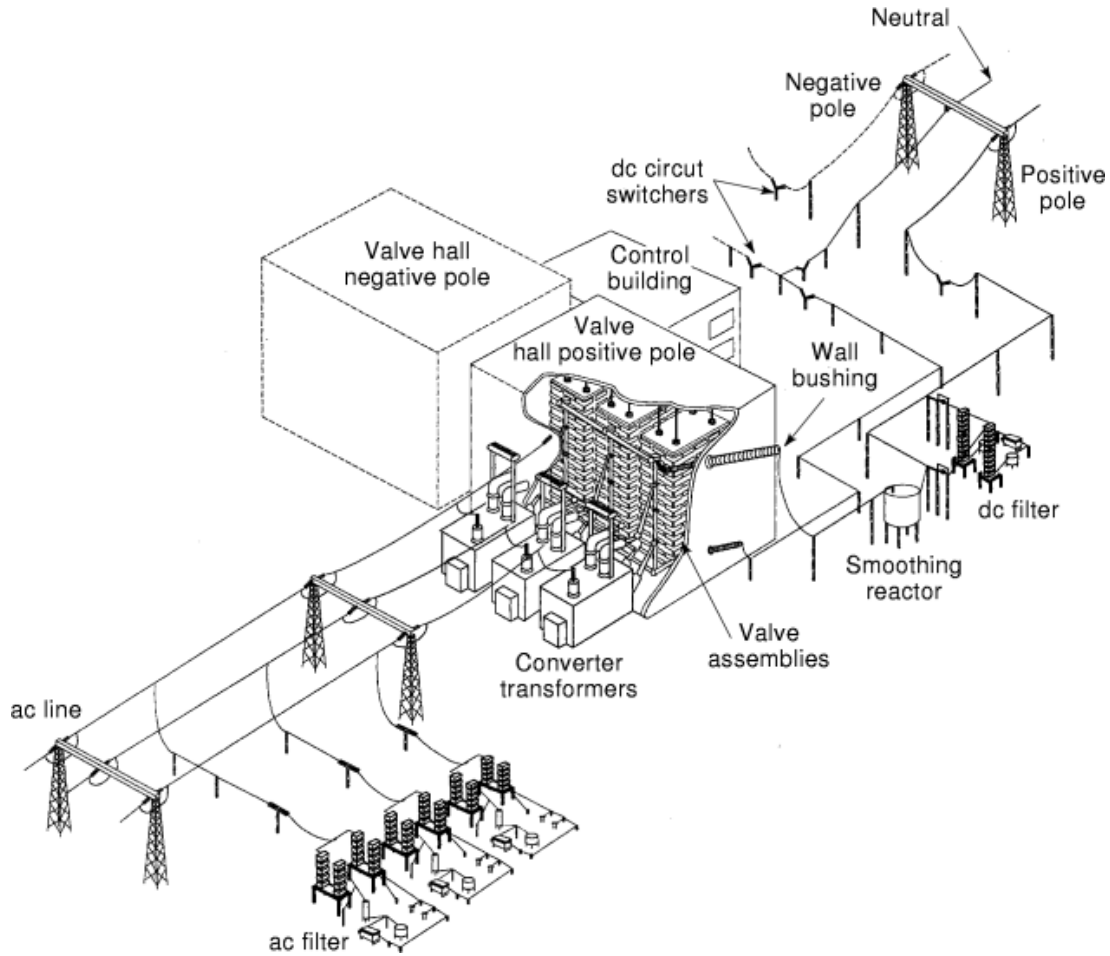
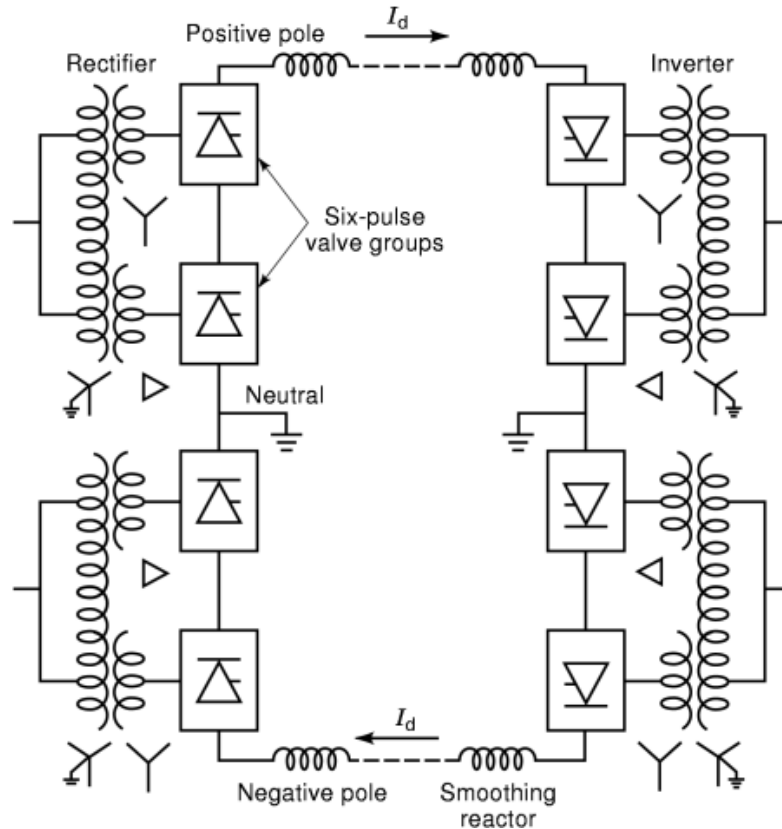

**Fig. 1.** Artist's rendition of a bipolar HVDC converter station that shows all key components of the positive pole. Portions of negative pole are shown to indicate location only. The neutral conductor shown on the same tower as the HVDC line connects to a separate electrode line some distance from the station and terminates at the ground electrode. (Courtesy Cutler-Hammer Co.)

dc transmission lines as a byproduct of the conversion process. These harmonic voltages could otherwise produce harmonic currents that, through induction, could disturb communication circuits located near the dc transmission line.

The positive pole and negative pole conductors represent the dc transmission line and carry the dc current between the two converter stations. A typical voltage on the positive pole for an overhead dc transmission line will fall between +250 and +500 kV. The voltage on the negative pole usually has the same magnitude and opposite polarity (-250 kV, for example). In Fig. 1, the neutral conductor is also shown leaving the station on the same towers as the pole conductors. Typically, the neutral conductor will separate from the HVDC line some distance away from the station to connect with a remote ground electrode. For certain cases, the neutral conductor may be carried the full length of the line instead of connecting to electrodes. The reasons for these variations will be discussed later.

#### 4 HVDC POWER TRANSMISSION

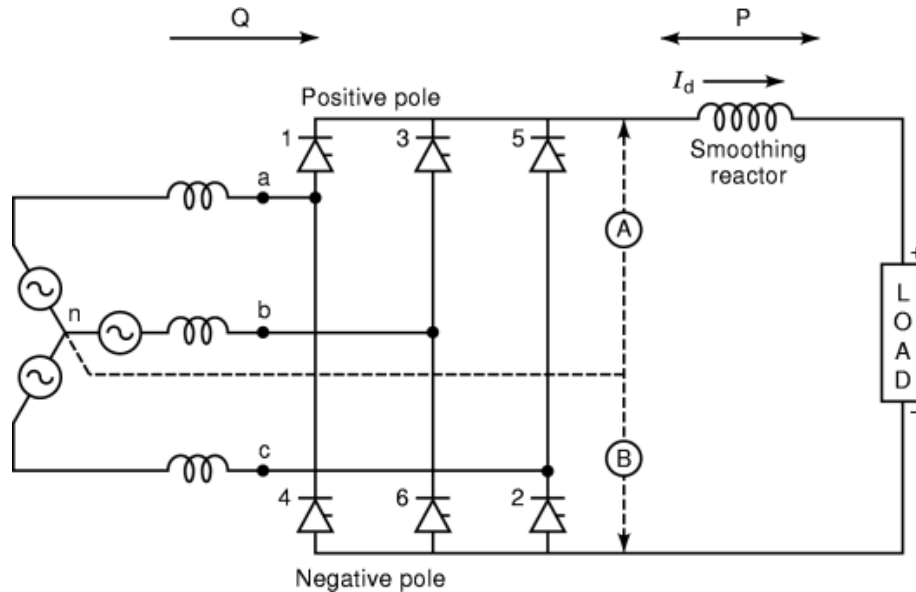

**Fig. 2.** The dashed lines in this one-line diagram of a bipolar HVDC system denote the transmission line. A back-to-back HVDC system would not have a line. Furthermore, most back-to-back systems consist of one pole wherein the neutrals are connected together and only one smoothing reactor would exist. (Courtesy Marcel Dekker)

The neutral conductor is used to carry current to the ground electrode on those rare occasions when one pole is disabled or the two pole voltages become unbalanced for some reason. Normally, there is negligible current in the neutral conductor. In a two-pole or bipolar HVDC converter station as shown in Fig. 1, it is usually possible to shut down one pole, which is one-half of the station, and operate only the remaining half. The y-shaped devices in the dc-side buswork represent special dc circuit switchers that are capable of interrupting and rerouting the direct current for just such occasions.

Sometimes the two converter stations are not separated by a long dc transmission line or cable. In those instances the two converter stations are adjacent in what is referred to as a back-to-back HVDC system. The back-to-back converter station operates in the same way as a “point-to-point” system, but the distance the power travels as dc is negligible. Because there are no line losses in such systems, they can operate at dc voltages as low as 25 kV.

**State-of-the-Art HVDC Systems.** State-of-the-art HVDC systems employ line-commutated converters using thyristors arranged in so-called “valve groups” in each converter. Figure 2 illustrates a “bipolar” system consisting of a positive pole and a negative pole. Each pole consists of two six-pulse valve groups at each end of the circuit. One converter (left-hand side of figure) is the rectifier (ac-to-dc) and the other is the inverter (dc-to-ac) end. In this configuration, the current flows  $I_d$  from the rectifier to the inverter on one pole conductor



**Fig. 3.** The six-pulse Graetz bridge is shown as a rectifier serving a dc load. A second six-pulse bridge could be connected after the smoothing reactor and operated as an inverter to serve an ac load. The firing order of the valves is indicated by sequence numbers. The two pole-to-neutral voltages A and B are discussed with the aid of Fig. 5.

and flows back on the opposite polarity conductor. The neutrals of the two poles are joined as shown, and connected to earth (ground) at each converter.

Unlike most low-power industrial applications of direct current systems, which are six-pulse systems, HVDC applications typically employ twelve-pulse groups as shown here. The two six-pulse valve groups per pole at each converter are connected in parallel on the ac side and in series on the dc side, forming a twelve-pulse group. By energizing the two six-pulse groups from wye-wye and wye-delta transformers, respectively, a  $30^\circ$  phase shift between transformer outputs results in a dc voltage that possesses a ripple with 12 pulses per cycle of the ac system frequency. The smoothing reactors help to reduce that ripple in the voltage, serve to maintain the current reasonably constant between switching instants, and prevent dc line surges from damaging the valves.

### How HVDC Converters Work

Each six-pulse valve group is a “Graetz bridge” arrangement of “valves” as shown in Fig. 3. A valve is a collection of thyristors arranged in series and parallel to obtain the desired voltage and current ratings. For simplicity, the inverter and HVDC line have been replaced by a dc load and the converter transformers and ac system are simplified to reactances in each phase. Current flows in each valve only after a “firing” signal is provided to all the thyristors in that valve. The amount of total direct current  $I_d$  is varied by controlling the start of conduction in each valve. Full rated current results if conduction is allowed to begin immediately when the voltage across the valve is positive. Less than rated current results by delaying the onset of valve conduction by  $\alpha$  degrees. Valve conduction ceases after the voltage across the valve reverses and the current decreases to zero. The firing instants on successive valves are timed following the numerical order indicated in Fig. 3 so the current “commutates” from one valve pair to another as smoothly as possible.

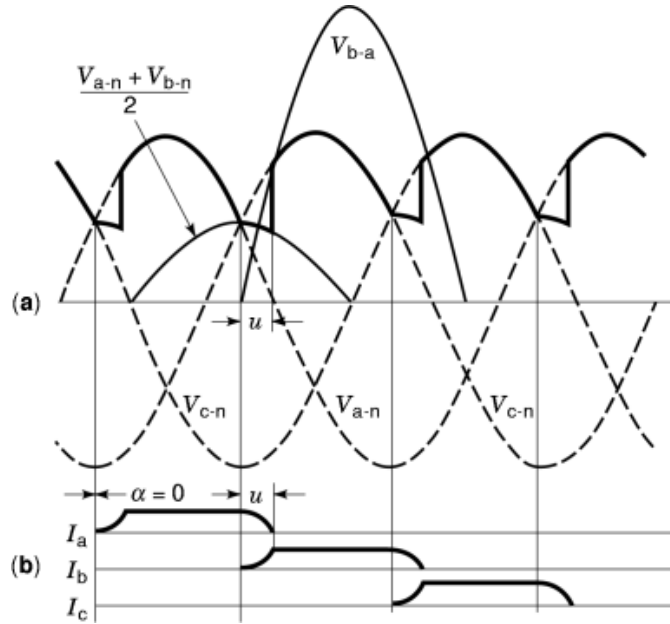

**Fig. 4.** The voltage and current waveforms for the top half of the six-pulse system in Fig. 3 are shown here. (a) Heavy lines show the dc voltage on the valve side of the smoothing reactor assuming only valves 1, 3, and 5 conduct. (b) Currents in the three phases are shown assuming only valves 1, 3, and 5 conduct. Delay angle  $\alpha$  is equal to zero. Current is assumed to return to neutral of the source through a wire not shown in Fig. 3. (Courtesy Marcel Dekker)

Figure 4 illustrates the commutation process for the rectifier in Fig. 3 assuming the delay angle  $\alpha$  is zero. That figure shows only conduction in valves 1, 3, and 5, for simplicity, assuming valves 2, 4, and 6 are blocked and the current returns from the load to the transformer neutral in a connection not shown. Only component A of the voltage applied to the load is shown in part a of Fig. 4. Part (b) of that figure shows that the current increases and decreases exponentially as dictated by the inductance of the circuit. The transformer inductance dominates this behavior of the current. The result is that the current in valve 1 continues to flow for a time after valve 3 commences to conduct. During that “overlap” period, which is  $u$  degrees in duration, transformer secondary phases a and b are paralleled and the dc voltage applied to the load is the average of the phase-to-neutral voltages  $V_{a-n}$  and  $V_{b-n}$ .

As shown in Fig. 5(a), the total voltage applied to the load is the difference between the voltage A (positive-pole-to-neutral) and voltage B which is defined as positive between the negative pole and neutral. Notice also that delay angle  $\alpha$  is nonzero in this case. This delay in conduction causes the load voltage to follow the ac line-to-neutral voltage longer before the valves are paralleled and the load voltage again becomes the average of  $V_{a-n}$  and  $V_{b-n}$  as before. The average voltage applied to the smoothing reactor and load is given by Eq. (1)

$$V_d = \frac{3\sqrt{2}}{\pi} V_{ac} \cos \alpha - \frac{3}{\pi} x_c I_d \quad (1)$$

where  $V_{ac}$  is the line-line rms ac voltage on the converter side of the converter transformer and  $x_c$  is the commutation reactance equal to the per phase converter transformer leakage reactance in ohms at fundamental frequency. Figure 5(b) shows the current waveforms in all phases. The coefficient of the cosine term is the no-load voltage (with  $I_d$  and  $\alpha = 0$ ) and is proportional to the larger of the two cross-hatched areas in Fig. 5(c). The

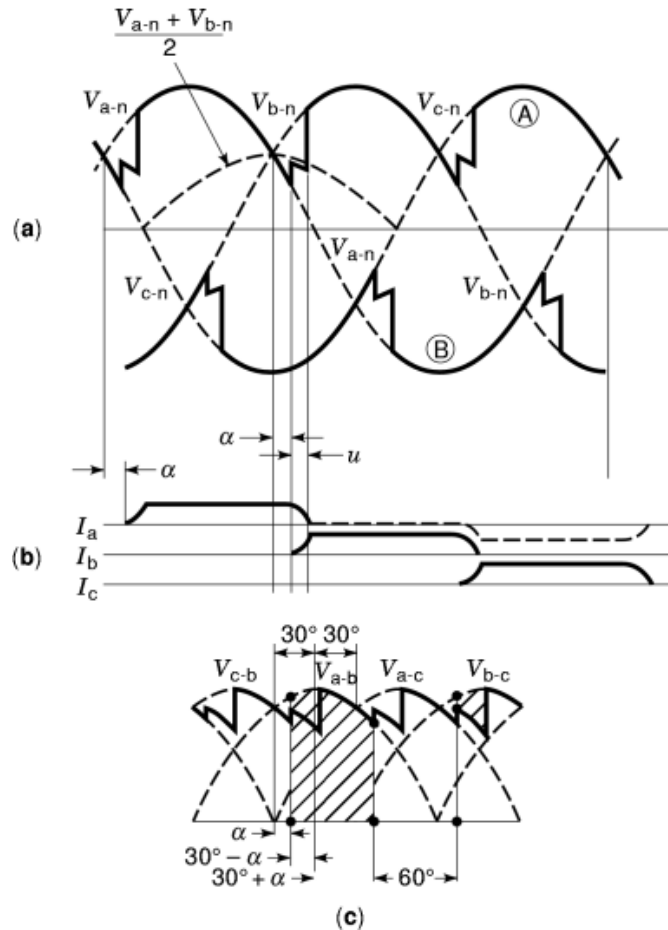
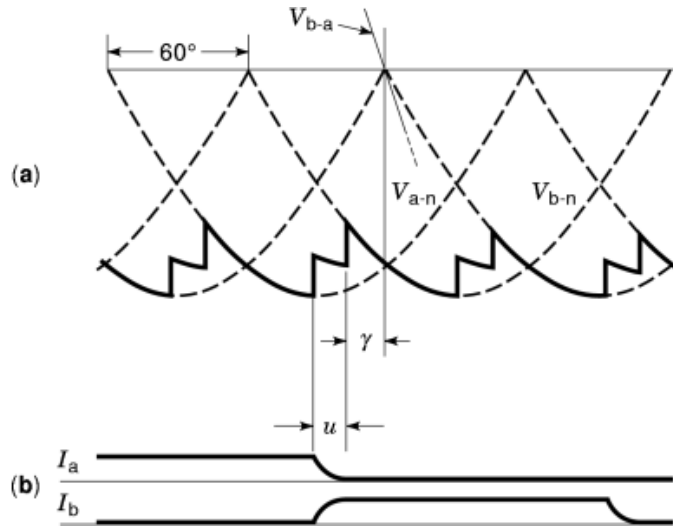

**Fig. 5.** This figure completes the voltage waveforms for the circuit in Fig. 3 with all valves conducting in sequence. (a) Heavy solid lines denote voltages A and B in Fig. 3 (b) The current waveforms in all phases are shown, with start of currents delayed by angle  $\alpha$ . Angle  $u$  is the overlap angle. (c) Complete dc voltage measured at output of bridge (A + B). The no-load dc voltage is the average value over a  $60^\circ$  period, and is proportional to the larger of the two cross-hatched areas shown. The smaller cross-hatched area is proportional to the voltage drop due to commutation.

second term is the voltage drop due to commutation under load and is proportional to the smaller cross-hatched area in Fig. 5(c).

A converter becomes an inverter when  $\alpha$  is greater than  $90^\circ$ . The average dc voltage at the inverter is computed using Eq. (1) with  $\alpha$  replaced by  $\gamma$ , the “extinction angle.” As illustrated in Fig. 6, the extinction angle is the angle between the instant the current reaches zero in valve 1 (commutates into valve 3) and the reversal of the “commutating voltage”  $V_{b-a}$ . The inverter controls maintain  $\gamma$  above a minimum value of (typically)  $18^\circ$  to avoid “commutation failure” (3) and possible collapse of inverter dc voltage.

Coordination of rectifier and inverter operating conditions results in control of the transferred power. Generally, the inverter controls the voltage and the rectifier controls the direct current. The inverter controls the voltage by adjusting  $\gamma$  until the desired voltage is obtained. The current is controlled by choosing rectifier  $\alpha$  such that the sending-end dc voltage is only sufficiently higher than the inverter-end dc voltage to yield the desired current. The received power is simply the inverter-end dc voltage times the direct current. Various



**Fig. 6.** Voltage and current waveforms are shown for inverter operation of the six-pulse bridge. (Courtesy Marcel Dekker)

well-established control schemes are employed to deal with normal and emergency variations in voltages, including faults on both ac and dc lines. The reader is directed to article 4 of Ref. 1 for a concise discussion on HVDC controls.

### Converter Transformers

The converter transformer is a special transformer designed to be an integral part of the conversion process. It must transform the utility system ac voltage to an optimum valve-side voltage for subsequent conversion to the desired dc-side voltage. Single-phase transformers are most common for large twelve-pulse HVDC applications. The transformers feeding one twelve-pulse group in Fig. 2 actually would consist of three 3-winding single-phase transformers. The primaries would be connected in grounded wye, the secondary windings in ungrounded wye, and the tertiary windings in a delta configuration.

Because the valve-side windings are ungrounded, they are exposed to dc bias voltages. Thus, the insulation levels must be greater than for standard ac transformers. The current in the valve-side windings is rich in harmonics that must be considered in selecting the megavoltampere (MVA) ratings. Also, to allow for precise control of the dc voltages when there are variations in the ac system voltages, the transformers generally are equipped with on-load tap changers (LTC). Control of the taps is integrated with valve firing controls to maintain dc voltage and current at desired values in spite of ac voltage changes caused by outside influences as well as in-station switching of harmonic filter banks to regulate ac voltage magnitude.

Three-phase transformers can be applied if they are available and economical. Conventional three-phase units are not available at MVA ratings associated with most large HVDC systems. Furthermore, when the cost of spares is considered, single-phase transformers are more cost effective than large three-phase units. The cost of converter transformers constitutes about 20% of the total cost of a converter station, which is almost equal to the cost of the valves and valve cooling.



## Harmonic Filters

The conversion process generates harmonics in the ac and dc voltages and currents which, if left uncorrected, can cause noise in nearby communications systems and possible resonant overvoltages on the ac transmission systems. Filters are needed on both ac and dc sides of the converters to minimize those problems. Because there are different issues on the two sides, the solutions also differ.

**Alternating Current System Harmonics.** The frequency spectrum of the characteristic harmonics associated with the conversion process is dictated by the formula  $n = kp \pm 1$ , where  $n$  is the harmonic number or multiple of the fundamental frequency,  $k$  is any positive integer 1, 2, 3, etc., and  $p$  is the pulse number. For twelve-pulse systems,  $p = 12$ ; thus the characteristic harmonics are the 11th, 13th, 23rd, 25th, etc., for most HVDC applications. Additional noncharacteristic harmonics, both integer and noninteger multiples of the fundamental frequency, are caused by imbalances in design parameters. The most serious of these results from imbalances in transformer inductances.

Harmonic filters (4) consisting of capacitors, inductors and resistors are generally located on the primary side of the converter transformers. They are configured, as appropriate, in bandpass, high-pass and other combinations to shunt the harmonic currents to ground. Perfect filtering is impractical, especially in the fact of inevitable variations in system voltages, the system impedances that parallel the filters, and ambient temperature. Therefore, filters are selected to reduce harmonic currents in the ac system to allowable levels to minimize overheating of power equipment as well as induced noise in telephone, television, radio and other communication systems. Established industry standards for maximum allowable current and voltage distortion are observed by the filter designer.

State-of-the-art filters that adapt to changing ambient and system conditions are becoming available, but most existing systems contain discrete switched filter banks. Except for the most elaborate filter schemes, their cost is typically less than 10% of the total cost of a converter station.

**Direct Current Side Filters.** Harmonics on the dc side are integral multiples of the pulse number  $p$ ; that is, the 12th, 24th, etc., harmonics of fundamental frequency. Filters (5) are required for all except back-to-back HVDC systems. The purpose is to limit the induction of noise-producing voltages in communication circuits in the vicinity of the dc line. Again, industry standards dictate the maximum tolerable noise induction. For bipolar operation, only the net difference of harmonics on the two poles must be considered since some cancellation occurs. Various filter configurations, similar to those on the ac side are employed. Generally, they are connected pole to neutral. They must work in concert with the series-connected smoothing reactor that is generally made as small as possible (low inductance) for economic reasons. Their selection depends also on the resonances and anti-resonances of the dc line over the 100 Hz to 5 kHz frequency spectrum. Otherwise, voltage amplification at antiresonant nodes on the line can cause high induced voltages in the locality of the dc line.

**Power Line Carrier Filters.** Many existing ac and transmission dc systems employ power line carrier (PLC) communications for control and protection. When used on a dc system, PLC filters must be placed in series with the dc line to block the control signals from straying where they are not wanted, for example, into the converter or into the ac network. When employed on the ac line side, they present an inductance that must be added to the converter transformer reactance when computing dc voltage and reactive power requirements. Fiber optics are gaining in popularity for broadband communications and replacing PLC communications; thus, PLC filters may not be required on new systems.

## Reactive Power Subsystem

Upon careful examination of the phase “a” current in Figs. 4 and 5, it can be seen that the fundamental component of that current is either in phase with, or lags (6) the phase-to-neutral voltage of that phase. That is, the current may start  $\alpha$  degrees after the phase voltage becomes positive, but always returns to zero when

## 10 HVDC POWER TRANSMISSION

the phase voltage passes through zero becoming negative. As  $\alpha$  is increased, the fundamental component of the current increasingly lags the voltage until  $\alpha = 90$  degrees, whereupon the current appears to be purely inductive. Therefore, for any active power flowing from the ac system into the rectifier, some reactive power is also drawn from the ac system.

It can be shown that the phase currents and phase-to-neutral voltages at the inverter also represent reactive power drawn from the ac system, even though in this case the ac system is receiving active power from the HVDC converter. That is, both the inverter and the rectifier absorb reactive power from their respective ac systems. This is a characteristic of line-commutated converter technology because the beginning of conduction can be delayed but the cessation of current flow always occurs at a natural current zero. Forced commutation, which will be discussed later, allows for turning off the current at any desired time. In such cases, the current can be made to lead the voltage and the converter made to “generate” reactive power.

The amount of reactive power ( $Q$ ) consumed by the rectifier for a given amount of active power ( $P$ ) transferred by the HVDC link depends upon the following equation:

$$Q = P \frac{u - \sin(u) \cos(2\alpha + u)}{\sin(u) \sin(2\alpha - u)} \quad (2)$$

where

$$u = \cos^{-1} \left[ \frac{V_d}{V_{do}} - \frac{x_c I_d}{v_{ac} \sqrt{2}} \right] - \alpha$$

and

$$V_{do} = \frac{3\sqrt{2}}{\pi} V_{ac}$$

with  $u$  and  $\alpha$  given in radians,  $V_d$  and  $V_{do}$  in kilovolts,  $x_c$  in ohms, and  $I_d$  in kiloamperes,  $V_{ac}$  is the rms line-to-line valve-side ac voltage in kilovolts.

The reactive power demand at the inverter obeys the same relationship with  $\gamma$  replacing  $\alpha$ . A reasonably good approximation to the exact result can be derived from the following:

$$Q = V_d I_d \sqrt{\left( \frac{V_{do}}{V_d} \right)^2 - 1} \quad (3)$$

For today's line-commutated systems, the reactive power needed to support commutation is usually provided by a reactive power supply subsystem (7) consisting of shunt capacitors connected to the “commutating bus” or the primary side of the converter transformer. Reactive power equal to about half the rated active power of the converter is required. In some cases, the reactive power can be supplied by nearby generators or the ac system itself. In other cases, the ac system also will require reactive power to support the flow of active power to or from the HVDC converter station. Then the reactive supply at the converter station must be large enough to serve the needs of both the converter and the ac system. In situations where the ac system has very low short-circuit duty at the converter station connection, a synchronous compensator may be required at the converter station to guarantee successful commutating performance. However, shunt capacitors generally are sufficient and are the lowest cost option for the reactive power supply.

To deal with high ac system voltages that exceed the LTC's capability to compensate, switched reactors may be added to the reactive power subsystem. Sometimes, rapidly varying voltages can occur for which switched

shunt reactors and capacitors cannot operate fast enough or often enough to regulate voltage adequately. In such cases, static var compensators may be employed to regulate the ac system voltage in the vicinity of converter stations. Regardless of the method chosen, a state-of-the-art converter must have a variable reactive power supply/absorption subsystem for successful operation.

The capacitor commutated converter (*CCC*) approach to converter design features series capacitors between the converter transformer and the valves. The series capacitors support commutation adequately, thus eliminating the need for large amounts of shunt capacitor compensation. Reference 8 describes the *CCC* design and discusses its operational advantages for weak ac system applications.

## Transmission Lines and Cables

Most HVDC transmission circuits in service today are overhead lines. However, the first commercial HVDC transmission project was a submarine cable connecting the island of Gotland to Sweden's mainland. Since 1954 when the first one was commissioned, the number of submarine cable systems has grown. They are found predominantly in the Nordic region of Europe and the island nations of southeast Asia. Long-distance transmission of bulk power is more cost effective with HVDC overhead lines than with ac overhead lines. Although each project is different, HVDC tends to be preferred over ac for long (800 km or more) overhead lines (9). HVDC submarine cables are necessary for distances exceeding 50 km because of the charging current limitations of ac cables. However, HVDC cables do not always enjoy the same advantage over ac cables for underground applications because shunt reactors can be located at strategic points in the underground ac cables to absorb the charging current. Further, there is a break-even distance between ac and dc underground cables where the cost of converters and ac reactors offset each other. Therefore, HVDC tends to be lower in cost for very long underground cable systems.

Overhead bipolar HVDC transmission lines require towers similar to high-voltage ac lines except that they must only support two conductors (usually multiconductor bundles) compared to three for the ac line. Sometimes, a neutral (third) conductor is used to avoid ground currents during emergency operation with one HVDC pole out of service. Even then, however, the conductor size and number of insulators for the neutral conductor are smaller than the pole conductors. As in the ac line case, the high-voltage "poles" typically are multiconductor bundles to reduce corona losses. Because skin effect is not an issue with direct current, the multiconductor bundles may provide more thermal capacity than required but the  $I^2R$  losses will be reduced along with the corona losses.

Tapping an HVDC line to serve a load along the point-to-point path of the line, while technically feasible, is more costly than tapping an ac line because the HVDC tap requires another converter station. Also, obtaining permits for HVDC overhead lines can be a lengthy and expensive process just as for ac lines. However, the static electromagnetic fields in the vicinity of an HVDC line are less controversial than the low-frequency fields associated with an ac line.

Although frequently it is easier to obtain right-of-way for underground and submarine HVDC cables than for overhead lines, they are more expensive to build and repair. Therefore, it is common to install one or more spare cables initially to permit continued operation during lengthy repair times. Most submarine cables are simply laid on the ocean floor where the risk of damage from ship anchors and fishing trawls is minimal. However, crossing busy shipping channels and harbors often requires that the cable be buried in the seabed. A depth of 1 to 2 m is common, bottom conditions permitting. Sandy or other soft ocean floors permit the use of a jet plow to speed the installation process. Underground cables are usually pulled in a steel conduit to provide some protection from damage due to construction accidents. Although more expensive than overhead lines, underground cables may be mandated in congested or environmentally sensitive areas.

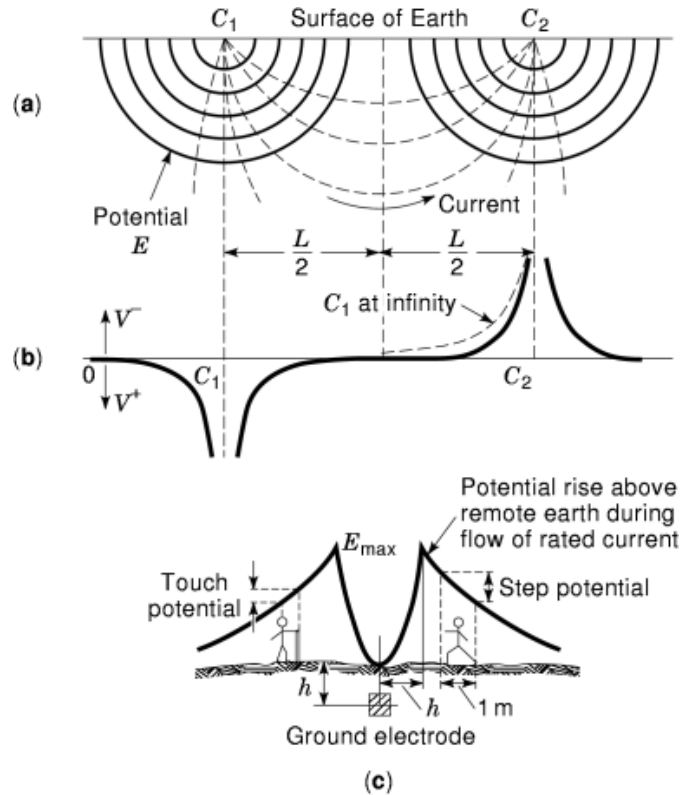

**Fig. 7.** Earth potential caused by direct current passing between electrodes  $C_1$  and  $C_2$  is illustrated here. (a) Lines of constant potential  $E$  and currents are shown for an ideal uniform resistivity earth. (b) Earth potentials peak near electrodes and decay with distance from electrodes. (c) The potential in the vicinity of the electrode is shown with null point directly above shallow electrode—the null is not shown in (b). The “step” and “touch” potentials measured in volts/meter are defined as illustrated. (Courtesy Cutler Hammer Co.)

### Electrodes and Electrode Lines

The neutral ground connections shown in Fig. 2 are made through “ground electrodes” that perform a vital function. They provide a path for the direct current if one of the poles ceases to be a viable current path. Under normal conditions the ground electrode provides a path for any small difference in the currents of the positive and negative poles. A separate ground grid is used to establish a ground potential connection for all equipment in the converter station.

Monopolar operation with earth return, which occurs when one pole is disabled, is usually an emergency mode only because passing high levels of direct current through earth can pose problems. The earth potentials caused by current flow near the surface can present unsafe step-and-touch voltages (Fig. 7) to humans and livestock. Also, the direct current can find its way into neutrals of transformers and other power devices causing equipment damage or misoperation. The direct current also causes electrolytic corrosion of conductive material located underground such as pipelines, water systems, communication cables and buried steel-reinforced concrete structures.

Locating the electrodes some distance from the converter station, remote from inhabited areas and underground utilities, minimizes many of these problems. The neutral connection is made by an “electrode line”

which is a distribution class overhead or underground circuit insulated for the resistive drop along its length, and for lightning and switching surges. The typical electrode line/cable extends 10 km to 20 km from the station it serves.

The site selection and design (10) of the electrode are critical for effective and low-maintenance operation. The site must have low to moderate resistivity to deep earth, present a suitable geology, and possess a reliable source of moisture. A large area of low-resistivity overburden with good connection to deep earth is ideal for a shallow electrode, such as that illustrated in Fig. 7. A deep-well electrode (8) is more suitable for areas with high-resistivity rock overburden or small areas with low resistivity. The cathodes making up the electrode must be used in sufficient numbers to accommodate the total current plus spare capacity to allow partial failure of cathodes. High current densities and dehydration of the surrounding medium must be avoided during operation to avoid exposing the electrodes to extremely high temperatures that can lead to electrode failure.

Sea electrodes offer excellent connection to deep earth and frequently are amenable to a cost-effective design. They may be embedded in a beach, suspended in deep water or they may rest on the ocean floor in shallow water. Protection of humans and aquatic life from shock and protection of the electrode from damage requires some form of enclosure. Access is also restricted because ammonia and other chemical compounds that are harmful to aquatic life can be formed near the electrode. However, they generally present little threat of corrosion damage to underground pipes. Some submarine cable systems run continuously in monopolar operation with sea return.

## Control, Protection and Communications

If the valves are the heart of an HVDC system, the controls are the brains. All variables including  $\alpha$ ,  $\gamma$ ,  $V_d$ , and  $I_d$  are tightly controlled with high bandwidth closed-loop controls. Digital control techniques have replaced analog controls in state-of-the-art systems. Protection on the dc side is done largely with the controls instead of with relays and circuit breakers as on the ac systems. For instance, the speed of the current controls is such that dc line fault currents are sensed and “valved off” rapidly so dc switches can interrupt the circuit if needed. Conventional ac system relaying schemes and circuit breakers are used to protect the ac side of converter transformers, harmonic filters, capacitors and all other ac-side equipment in HVDC converter stations.

Some form of communications must be used to coordinate the controls of the converters at both ends of the line. While voice-grade telephone circuits can be used in an emergency, modern systems typically use high bandwidth communications for normal operations. Microwave, power line carrier and fiber optic cables also are options. Unless an existing microwave system can be utilized, it is the most expensive option. Fiber optic cables are becoming common, as they can be integrated with the “shield wires” of overhead dc lines or integrated with underground and submarine dc cable installations.

## Performance and Reliability

Statistics on the performance and reliability of most of the world’s HVDC power transmission systems can be found in the periodic publications of *CIGRE* (11). By counting forced outages and planned outages for scheduled maintenance as unavailability, many HVDC systems are able to achieve annual availability levels of 99% and higher.

While high availability would allow an HVDC system the opportunity to transmit high amounts of energy, many systems have reported recently that other factors limit the amounts of energy transmitted (12). Today, energy contracts and ac system limitations often limit the amount of energy transmitted below what the HVDC system’s availability allows. HVDC systems built to transmit power from remote generating plants to load centers often find that the availability of the HVDC system is greater than that of the generating plant.

## 14 HVDC POWER TRANSMISSION

Therefore the energy transmitted is less than the HVDC transmission system itself was capable of for a given period of time.

The performance of an HVDC system under various system conditions is determined primarily by its control system. Besides reacting to faults in the HVDC system such as a temporary line-to-ground fault of the HVDC transmission line, the control system is designed to handle changes in the ac system at either the rectifier or inverter. A small temporary ac voltage change at the rectifier or inverter usually is met with a temporary change in  $\alpha$  or  $\gamma$  at the affected converter station. A large transient ac voltage reduction at the inverter, such as 10% or more, generally results in a single commutation failure. A commutation failure means that the dc current in the valve does not successfully commutate (transfer) from one valve to another as it is meant to in the Graetz bridge. By contrast the ac system is not seriously impacted by a single commutation failure. A fault on a dc line is cleared by bringing the dc current in that faulted pole to zero by changing  $\alpha$  or  $\gamma$ . A delay of approximately 150 ms allows the arc path to deionize, after which the dc current is restarted.

### Operation and Maintenance

Today's HVDC systems are highly automated and require limited human input during steady-state operation. Starts, stops, and power level changes are usually initiated by human operators, but then the sequence of necessary steps is done automatically by the control system. The protection system will automatically trip all or part of an HVDC system when it detects a serious problem. Delayed trips also can be initiated by the protection system, which gives the human operator time to respond to a situation and perhaps avoid the trip. However, it is still necessary to provide the operator with emergency trip capability so that those rare events that the protection system cannot interpret correctly can be prevented from causing ac system disruptions or further HVDC equipment damage.

Today's technology allows for remote operation of an HVDC system. This is often done to take advantage of workers available at another location 24 h a day, thereby reducing the cost of operation. A recent survey suggests that about half the HVDC systems in the world at present are operated remotely, while the remainder have on-site operators (12).

Because some HVDC systems cross international borders, coordinating the operation of an HVDC system can be complicated by different languages, customs, and business practices. Common interests in safe and reliable operation, which will allow the benefits of the HVDC tie to be realized by diverse groups, will allow effective working relationships to develop.

To achieve high availability levels, redundant equipment can be built into the system to allow maintenance and repairs while the HVDC system, or at least part of it, continues to run. If high availability is not critical, the capital cost of an HVDC system can be reduced by eliminating redundant equipment. In a two-terminal system, scheduling maintenance outages of the transmission line and both stations simultaneously maximizes availability of the system. In the same way as with ac equipment, switching, tagging, isolating, and grounding procedures are necessary to insure workers' safety.

Much of the equipment on the ac side of an HVDC station is similar to ac substation equipment and is maintained in a very similar manner. Thyristor valves, valve cooling systems, and control and protection systems require specialized HVDC knowledge to maintain and repair. In outdoor areas of the HVDC station subjected to dc electric fields, particulate pollution from the air will collect differently on bushings and insulators. To avoid flashovers following or during light rain, regular cleaning or silicone grease applications may be necessary, particularly for dc wall bushings.

To date, most HVDC systems are largely custom designed. That increases the cost and lowers the availability of many components over the years of operation of an HVDC system. Large quantities of spares of the specialized parts are often purchased when the system is built. HVDC equipment suppliers are trending

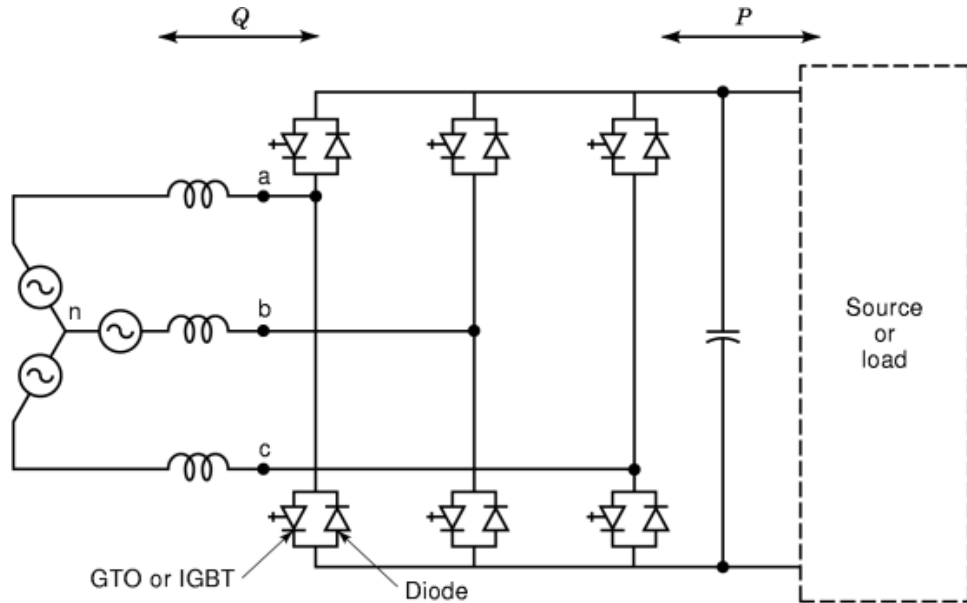

**Fig. 8.** A voltage-source converter (VSC) one-line diagram is given. GTOs or IGBTs are shown in antiparallel with diodes. Such inverters allow bidirectional reactive power flow ( $Q$ ), not unidirectional flow into the line-commutated converter as shown in Fig. 3. (Courtesy Marcel Dekker)

toward more standard, modular designs and less customization. This should increase spare part availability and reduce spare part prices for future HVDC systems.

*Future Needs and Applications (13).* Electric power transmission and distribution systems in the future must be capable of higher power densities, provide more flexibility in power routing, satisfy growing environmental restrictions and cost less to build and operate. HVDC lines already can transmit nearly double the power of ac lines of similar voltage and construction. The power on the dc line is precisely controllable, almost independent of the condition of the adjacent ac networks, and some would say, HVDC lines present less disruption to the environment than ac lines. With all that, HVDC is less prevalent because of the higher cost of the dc line terminating stations, namely, the converters. Both the added terminal cost and certain technology limits make taps on dc lines prohibitive compared to ac lines. Ongoing technology developments can change these conditions and make HVDC cost effective in more applications.

### Advanced Devices and Controls

Gate-turn-off (*GTO*) thyristors and integrated-gate-bipolar-transistors (*IGBT*) are only two of the numerous solid state power electronic devices under development that could revolutionize HVDC converter applications (14). Because they can turn off the current upon command, converters constructed with such devices will find more widespread application. They do not demand as much reactive power—indeed they can even “generate” reactive power—and they will be immune to commutation failure during ac system disturbances. When such devices are used back-to-back with diodes in voltage-source commutated converters, as shown in Fig. 8, many of the objections and limitations of the traditional current-source line-commutated converters vanish.

Although the voltage and current ratings of these devices continue to increase steadily, they will not soon be suitable for long-distance HVDC transmission use. However, use for low-voltage low-power applications

## 16 HVDC POWER TRANSMISSION

is possible in the shorter term. The continued development of these devices and circuit arrangements for application in Flexible AC Transmission Systems (*FACTS*) controllers should further advance their development for HVDC applications as well. Meanwhile, the capabilities of the thyristor, which is considered (9) the “workhorse” of the conventional HVDC system, will continue to increase incrementally from continued advances in materials and manufacturing brought about by research on and development of the more advanced devices.

### Transformerless Converters

After the thyristor valves, the converter transformer is the second costliest element in a converter station. Thus, a transformerless converter would seem to be a worthwhile goal. Research in this direction (15) has shown that added cost in the valves to accommodate direct connection to voltages up to 500 kV ac could more than offset the savings. However, lower voltage applications, such as subtransmission laterals in and around urban load centers, may benefit from such an approach. Such applications could demand underground cables, thereby making direct current technically superior to ac, especially for distances of over 50 km. Combined with voltage-source converters, direct current networks would be feasible and might be preferred for reliability in such dense load areas.

### Unit-Connected Converters (16)

Interconnecting large generating facilities located at long distances from load centers can sometimes be done cost effectively with HVDC transmission. Large hydrogeneration complexes such as Itaipu in Brazil and James Bay in Quebec, Canada are such examples. The economics of such projects would be improved by the “unit-connected” concept, which involves the direct connection of the HVDC converter transformer to the generator(s), thus saving the cost of a separate generator-step-up transformer. It might also be possible to use diodes instead of thyristors in the converter for additional savings because the converter would never need to act as an inverter. By contrast, using thyristors and allowing the hydro units’ speed to vary with changing head might allow more efficient operation of the turbine-generators—a different form of savings. There is considerable interest in this approach in areas of the world where high-head hydrosites are yet to be developed.

### Multiterminal High Voltage Direct Current Transmission

HVDC transmission systems with more than two terminals are called multiterminal systems. Existing systems that operate part of the time in a multiterminal mode are the Nelson River system, the Hydro-Quebec New England interconnection (17), and the Italy-Corsica-Spain systems. Unrestricted multiterminal operation is limited somewhat by the lack of flexibility and robustness inherent in line-commutated technology. If one of the terminals is connected to a weak ac system, performance of all of the converters on the HVDC system is degraded whenever that ac system suffers a serious disturbance. Because the dc voltage must be reversed to change power direction at any given terminal, reversing switches are required at all terminals for maximum flexibility of power dispatching.

Future application (18) of voltage-source converters (*VSC*) will mitigate these objections. Power reversal in one leg can be done by reversing current in that leg without reversing the voltage. Further, the *VSC* is virtually immune to commutation failure so ac disturbances near one terminal will not degrade the operation of the remainder of the HVDC multiterminal network. Thus, a remote community traversed by the HVDC line



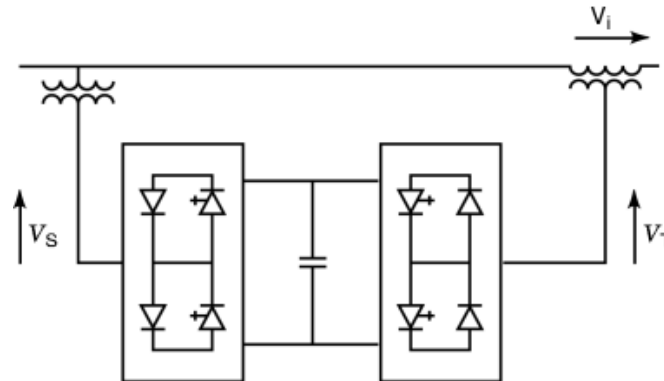

**Fig. 9.** This one-line diagram represents a UPFC (unified power flow controller) involving two VSCs connected together with the dc bus containing the commutating capacitor. The VSC on the right is connected to a series boost/buck transformer. The series voltage  $V_i$  acts to regulate magnitude and phase angle of the terminal voltage  $V_T$ . The power flowing between  $V_S$  and  $V_T$  is also controlled since it is proportional to the phase angle between those voltages. (© 1997 IEEE)

might tap the line for its needs without being a liability to the transfer of bulk power over the line. It might then decommission its expensive-to-operate local diesel generation or use it only for backup.

### Power Flow Control

Future HVDC back-to-back links could be used as power flow regulators. Currently, the control of power flow patterns in ac networks generally requires that the dispatched generator outputs be rearranged to force a desired pattern. Power angle regulating (*PAR*) transformers in strategic locations of the network also help in achieving the desired flow patterns. More often they are used to limit flows on easily overloaded lines. There is a clear need to implement more power-flow-control measures in the transmission systems in order to achieve a more effective utilization of the transmission assets.

One form of FACTS technology called the Unified Power Flow Controller (*UPFC*) (19) controls the power in the line in which it is connected in series. As shown in Fig. 9, a series voltage  $V_i$  is added in a phasor sense to the source voltage  $V_S$  to yield a phase-shifted terminal voltage  $V_T$ . Because the UPFC employs voltage-source converter technology, it can also control the reactive power to regulate the magnitudes of both  $V_S$  and  $V_T$  at the same time that it controls active power through the series transformer.

The UPFC's range of phase shift is dependent on the voltage rating of the series winding and inverter and is limited in the steady state by practical limitations on the terminal voltage. The magnitude of that voltage must remain within  $\pm 5\%$  of rated value. For some applications where a wide range in power flow control is required, the two converters in Fig. 9 could be replaced by two connected back-to-back (20) as a dc link. The added cost of that approach will need to be justified by the added benefit of full 100% power control in both directions. The technology will soon exist to apply VSCs either way, depending on the need and economics of each individual situation.

### Conversion of AC Lines to DC Operation

The power-carrying capacity of an ac line is limited due to thermal, voltage or stability considerations. The latter two reasons are associated with heavily utilized long lines while thermal limits exist regardless of distance.

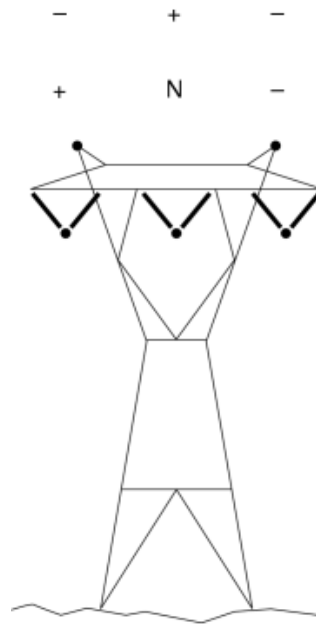

**Fig. 10.** An ac line energized as a direct current line. The center phase can be reused as a positive pole (top sequence of  $- + -$ ) or as a neutral conductor N. Not shown is the option where center phase is discarded entirely. (Courtesy Marcel Dekker)

Because conductors carrying direct current do not encounter skin effect as in ac applications, the entire cross-sectional area is available. Therefore, a conductor sized for a specific ac power level may accommodate twice as much power thermally for comparable dc voltage applications. This fact has led engineers (21) to consider possible conversion of ac lines in highly loaded corridors to HVDC operation to achieve greater power densities. Theoretically, one need only replace the insulator strings with others better suited for HVDC and energize the line at a dc voltage equal to the peak ac voltage for which the line was designed.

Figure 10 illustrates two possible schemes for reuse of a single-circuit ac line as a bipolar HVDC line. One scheme employs the center phase conductor as a metallic neutral to avoid ground currents during single-pole outages. The second scheme uses the two outer conductors as the negative pole and the center as the positive pole. A temporary outage of one pole due to a line (conductor) fault would require ground return of the current during the outage, a practice which is usually permitted in emergency situations. There are other issues to address in such a conversion, but all are solvable with present technology and may become less costly in time.

### Serving Isolated Loads

Isolated load centers exist throughout the world. Mining communities in Western Australia, the islands of Southeast Alaska and remote communities in northern Canada (22), for example, all rely on costly oil-fired local generation for their electric supply. With voltage-source converter technology, direct current lines of modest capacity could interconnect some of these remote loads to the nearest grid where lower-cost resources are available. The VSC system could serve loads with no local generation support, and technically are capable of multiple taps along the way. Indeed, such technology applied to submarine cable applications may also serve

to provide incremental capacity to urban centers located along seacoasts and on major rivers, without erecting additional overhead lines on already congested corridors.

## Conclusions

HVDC power transmission has proven to be advantageous in applications where alternating current transmission is more expensive or technically inadequate. As the capabilities of direct current conversion technology increase and/or the costs decline, direct current will find more applications in the transmission and distribution of electric energy. New and cost-effective devices and circuits are the key to the increased application of dc in power delivery systems. Continued development of FACTS technologies and methods for interfacing ac systems with dc storage systems such as batteries and superconducting magnets will yield devices and circuit techniques that will find use in dc power delivery systems as well. Research and development efforts that are focused solely on dc-based power delivery systems also are necessary to capture the benefits discussed in the previous section. One way or another, dc-based power delivery solutions will continue to play a role in the world's evolving electric energy supply systems.

## BIBLIOGRAPHY

1. J. Arrillaga *High Voltage Direct Current Transmission*, London: Peter Peregrinus, Ltd., for IEE Power Engineering Series, 1983.
2. C. M. Stairs J. L. Fink A. L. Molnar Eel River: Vanguard of solid-state HVDC, *Transmission*, **6** (1): 7–11, 1974.
3. E. W. Kimbark *Direct Current Transmission*, Volume I, Chapter 3, New York: Wiley-Interscience, 1971.
4. E. V. Larsen N. W. Miller AC filtering effects—Panel session on specification of filters for HVDC systems, *Proc. IEEE T&D Conference*, New Orleans, April 3–7, 1989.
5. P. Danfors D. Dickmader DC filtering effects—Panel session on specification of filters for HVDC systems, *Proc. IEEE T&D Conference*, New Orleans, April 3–7, 1989.
6. E. W. Kimbark *Direct Current Transmission*, Volume I, Chapter 3, New York: Wiley-Interscience, 1978, p. 78.
7. R. J. Piwko (ed.) *High-Voltage Direct Current Handbook*, 1st ed., Chapter 9, Palo Alto, CA: Electric Power Research Institute, 1994, pp. 137–150.
8. L. Carlsson *et al.* New concepts in HVDC converter design, *Proc. CIGRE 36th Conference on Large High Voltage Systems*, Paris, Aug. 28–Sept. 3, 1996, paper 14-102.
9. N. G. Hingorani High-voltage dc transmission: a power electronics workhorse, *IEEE Spectrum*, **33** (4): 63–72, April 1996.
10. R. J. Holt J. Dabkowski R. L. Hauth HVDC power transmission-electrode siting and design, *Report ORNL/Sub/95-SR893/3*—U.S. National Technical Information System, Washington, DC, April 1997.
11. D. J. Christofersen H. Elahi M. G. Bennett Survey of the reliability of HVDC systems throughout the world during 1991–1992, *Proc. 35th Session of CIGRE*, Paris, Aug. 28–Sept. 3, 1994, paper 14-101.
12. J. J. Cochrane *et al.* A survey of HVDC operating and maintenance practices and their impact on reliability and performance, *IEEE Trans. Power Delivery*, **11** (1): 514–518, 1996.
13. R. L. Hauth *et al.* HVDC power transmission—technology assessment, Chapter 4, *Report ORNL/Sub/95-SR893/1*—U.S. National Technical Information System, April 1997.
14. N. Mohan T. M. Undeland W. P. Robins *Power Electronics—Converters, Applications and Design*, 2nd ed., New York: Wiley, 1989.
15. J. J. Vithayathil P. Bjorlund W. A. Middlestadt DC systems with transformerless converters, *IEEE Trans. Power Delivery*, **10** (3): 1497–1504, 1995.
16. J. G. Campos-Barros Direct connection of generators to hvdc converters: main characteristics and comparative advantages, *Electra*, (149): 19–39, Aug. 1993.

## 20 HVDC POWER TRANSMISSION

17. Y. Allard *et al.* Multiterminal operations experience: Hydro-Quebec/NEPOOL Phase II HVDC network, *CIGRE Study Committee 14 International Colloquium on HVDC and FACTS*, Montreal, Sept. 1995.
18. Z. Zhao M. R. Iravani Application of GTO voltage-source inverter for tapping HVDC power, *IEE Proc. on Generation, Transmission & Distribution*, **141** (1): 19–26, Jan. 1994.
19. L. Gyugyi *et al.* The unified power flow controller: A new approach to power transmission control, *IEEE Trans. Power Delivery*, **10** (2): 1995.
20. R. L. Hauth *et al.* HVDC power transmission-technology assessment, Chapter 3, *Report ORNL/Sub/95-SR893/1*—U.S. National Technical Information System, April 1997.
21. A. Clerici L. Paris P. Danfors HVDC conversion of hvac lines to provide substantial power upgrading, *IEEE Trans. Power Delivery*, 324–333, 1991.
22. J. Bowles Application of dc feeders for isolated loads, *Report 174-T-923*, Canadian Electric Association, Oct. 1994.

JACQUELINE J. COCHRANE  
New England Power Company  
RONALD L. HAUTH  
New England Power Service Company