

MICROWAVE PARAMETRIC AMPLIFIERS

INTRODUCTION

It has been known since nineteenth century that a mechanical system or an electric circuit in which there is a parameter that varies periodically with time may oscillate under certain conditions. The first use of this periodic variation to amplification, frequency changing, or harmonic generation was investigated in the 1940s, but real progress in the parametric amplification dated from the development in the mid-1950s of semiconductor diodes in which the barrier capacitance could be modulated at microwave frequencies. Since then, there has been a continual and tremendous increase in the amount of theoretical and experimental work devoted to parametric amplifiers (1–11). This is because of their ability to maintain a low level of noise that is inevitably introduced at each stage of analog signal processing. A typical microwave receiver of the early 1960s consisted of a silicon point-contact diode mixer followed by a vacuum-tube amplifier. The addition of a parametric amplifier (or *paramp*, as it was popularly called) ahead of the mixer gave an order of magnitude improvement in sensitivity of the receiver.

The question arose at that time as to why the parametric amplification allows noise levels lower than with the usual type of amplifier. To answer this fundamental question, it should be remembered that an amplifier consists of both passive elements and active energy sources and that the whole is terminated by two ports, one receiving the signal to be amplified and the other delivering the amplified signal. In the ordinary type of amplifier, the energy sources consist of DC sources that are incorporated into a network of passive elements that may be linear or nonlinear. The essential condition for such a system to act efficiently as an amplifier is the inclusion of a nonlinear and/or electrically controlled resistive element to provide an energy transfer from the source to the signal (11). Unfortunately, its operation is accompanied by a background noise that is an inevitable result of its dissipative character. In order to obtain an amplifier with a low noise level, the energy must no longer be supplied to the network directly from DC sources, and so other methods of energy transfer must be envisioned. One of these methods is to employ AC sources. It has been shown (1,4,6,8) that if a nonlinear reactance is incorporated in the network, a system of this kind may be used efficiently as an amplifier. In such a parametric amplifier a nonlinear reactance does not generate any noise, provided it is free from loss.

The first practical realization of the principle of transferring energy from a “pump” source at a high frequency to a signal at a lower frequency was based on a nonlinear inductance (2,3,7), with the nonlinearity depending on the properties of ferrite materials. Unfortunately, large levels of pump power were required to provide the necessary nonlinearity. With pump levels in the kilowatt region and relatively high loss in the reactance, this type of amplifiers had only very limited applications.

Capacitive parametric amplifiers depend on the nonlinear capacitance–voltage characteristic of semiconductor diodes. The diodes, which are specially made for the purpose, are called *varactor diodes* or more simply *varactors*. When used in a parametric amplifier, the varactor junction is biased in the reverse direction to prevent current flow across the junction and thus suppress “shot” noise associated with the current, leaving only thermal noise present in series resistance of a real diode. The effective noise level of the amplifier depends on both the signal and pump frequencies as well as on the properties of the diode, and, as it is thermal in origin, the noise level also depends on the temperature of the diode. Thus, it can be lowered by cooling the amplifier.

Varactor parametric amplifiers could be operated at convenient temperatures from room temperature, through liquid nitrogen temperature, down to liquid helium temperature, and offered versatility of system design. These amplifiers gained popularity because the improvement in sensitivity they offered outweighed the complications they introduced (the requirement for a low-loss ferrite circulator and a high-power, high-frequency pump oscillator—coupled with a reputation for being touchy to operate) (12). Among uncooled amplifiers, the parametric amplifier was the most sensitive amplifier in existence in the 1960s. The noise level of a cooled paramp was not as low as that of a maser, but the paramp was much smaller and much less costly and did not require a liquid helium cryostat to operate. The wideband ultra-low-noise paramps (5,6,9) had been the key devices that had brought commercial and military communication satellite systems into existence. They also dominated in radio astronomy receivers throughout the world, opening new horizons in exploration of our universe. The growth in technology of the wideband paramps in the late 1960s had been exceptionally rapid. The microwave parametric amplifier evolved from a relatively high noise temperature device (250–300 K) with narrow bandwidth of 25–50 MHz to one capable of operational noise temperature as low as 12 K in cryogenically cooled mode and as low as 50–120 K in an uncooled mode and 1 dB bandwidth in excess of 500 MHz. In the early 1970s, Peltier cooled paramps were the configuration of the day.

In the early 1980s parametric amplifiers were challenged by gallium arsenide field-effect transistor (MESFET) amplifiers. With their simplicity and cost advantages, the MESFETs were encroaching on the previously exclusive property of the paramps, eroding their monopoly. Rapid improvement in GaAs MESFET technology and development of the high-electron-mobility transistor (HEMT) resulted in lower intrinsic noise, and thus less noisy amplifiers, leaving paramps behind in the race for the highest sensitivity (13) and finally displacing them at microwave frequencies. But the elegance and refinement of the parametric amplification are still fascinating, and the technique might emerge in its classical form at the terahertz region of the electromagnetic spectrum where there are no active semiconductor devices but there are many powerful far-infrared lasers to pump contemporary submillimeter-wave varactors (14). More recently optical control in optoelectronic devices and nonlinear interaction between optical and microwave signals in semiconductor devices have

gained much interest because of potential application in signal switching, mixing, and frequency modulation. Parametric amplification plays an important role in increasing sensitivity of such devices employing semiconductor photodetectors (15, 16).

PRINCIPLE OF OPERATION

In a parametric amplifier, the energy at one (signal) frequency is increased by supplying energy at a second (pump) frequency. The basic idea is illustrated in Fig. 1. Considering the simple resonant circuit of Fig. 1, it is assumed for the purpose of illustration that the plates of the capacitor can be separated mechanically (2, 17). Let us assume that prior to a time $t=0$, the circuit has been induced to oscillate at its resonant frequency. Suppose that when the charge in the capacitor is reaching its first maximum after $t=0$, separation of the plates is suddenly increased, thereby decreasing the capacitance. Because of the electric field, this separation requires mechanical work to be supplied. The relation between charge q , capacitance c , and voltage v on a capacitor is, of course, $q = cv$. Thus, if the plate separation is increased and the capacitance thereby decreased, in a time short enough for q to be considered essentially constant, the voltage and also the stored energy $qv/2$ must both be suddenly increased. If, at the next zero of voltage across the plates, the original separation is suddenly restored, this does not change the stored energy of the circuit since the field is then zero. If the whole sequence is then repeated every half-cycle, the voltage and energy may also be increased every half-cycle, giving a buildup of the voltage across the capacitor and the energy stored in the circuit (thus also the charge in the capacitor). This buildup will continue until the energy added by separation of the plates exactly equals the energy dissipated in the circuit. It should be noted that the plates are moved (or "pumped") at twice the resonant frequency and that the phase of the pumping is important. A variable-capacitance amplifier operating exactly on this principle, in which a signal is supplied at the resonant frequency f_s with the pump frequency $f_p=2f_s$, is called a *degenerate amplifier*.

Nondegenerate parametric amplifiers, which do not impose this restriction on pump frequency or phase, can be constructed by connecting a second tuned circuit across the variable capacitance. This circuit is known as the *idler*, and its frequency f_i is tuned to $f_p - f_s$. Operation of such an amplifier can be explained in much the same way as above for the single resonant circuit; interested readers may refer to Ref. 17.

In practical circuits a semiconductor junction is used as an electronically variable capacitance instead of a mechanically controlled parallel-plate capacitor. The waveform changing such a capacitance is sinusoidal (rather than rectangular) and is produced by a special generator (called a *pump*) pumping energy to the nonlinear capacitance. The theoretical power flow into and out of an idealized lossless nonlinear reactance is described in terms of two generalized equations known as the Manley-Rowe

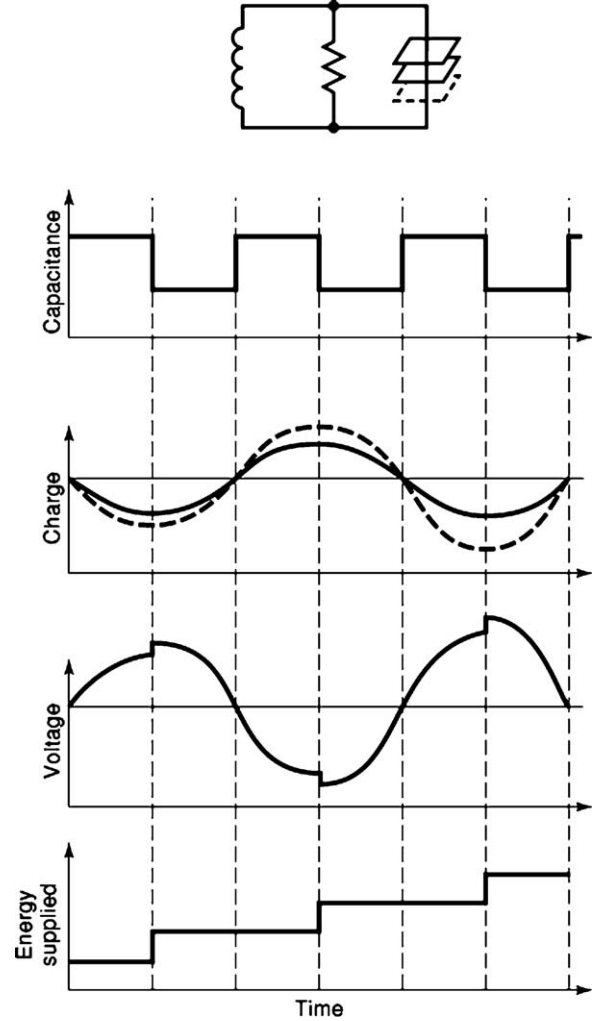

Figure 1. Illustration of basic parametric amplifier principle. The separation of the plates forming the capacitor is increased (thus the capacitance is decreased) so fast that the charge q remains constant, giving buildup in voltage $v=q/c$ and stored energy $qv/2$. Original separation is then restored at the moment when $q=0$. The whole sequence is repeated every half-cycle.

relations, which can be written as

$$\begin{aligned} \sum_{m=0}^{\infty} \sum_{n=-\infty}^{\infty} \frac{m P_{mn}}{m f_1 + n f_2} &= 0 \\ \sum_{n=0}^{\infty} \sum_{m=-\infty}^{\infty} \frac{n P_{mn}}{m f_1 + n f_2} &= 0 \end{aligned} \quad (1)$$

where P_{mn} represents, algebraically, the power flow into the nonlinear reactance at the frequencies $m f_1 + n f_2$. These equations are a result of only the nonlinear variation of the reactance and are independent of the shape of the reactant's characteristic and of the driving power levels. The spectrum of signals at the nonlinear reactance is illustrated at Fig. 2. If we consider a typical case of three-frequency amplifiers (however, more frequencies may be used in some specific applications)— f_1, f_2, f_3 , where $f_3=f_1+f_2$ —then, provided $f_1 \gg f_1 + f_2$, the general Manley-Rowe equations

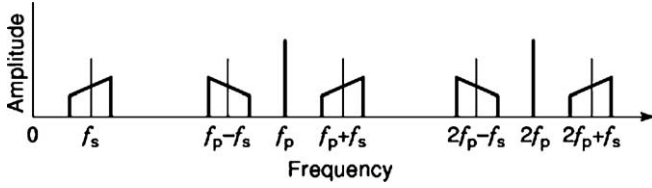

Figure 2. Spectrum of signals at a nonlinear reactance. Input signal spectrum (f_s and its vicinity) appears at both sides of the harmonics nf_p of the pumping signal.

can be simplified to

$$\frac{P_1}{f_1} + \frac{P_3}{f_3} = \frac{P_2}{f_2} + \frac{P_3}{f_3} = 0 \quad (2)$$

This equation and Fig. 2 can be used to understand the operation of some of the different types of parametric amplifiers (nonlinear capacitance is assumed here to be lossless).

Let $f_1=f_s$ be the signal frequency and power be supplied from an external source at frequency $f_2=f_p$. Since pump power $P_2=P_p$ is supplied to the capacitor ($P_p>0$), then $P_3<0$ represents power leaving the reactance at the frequency $f_3=f_p+f_s$; hence $P_1=P_s>0$. It follows that the device is absolutely stable and has the maximum power gain equal to $f_3/f_1=1+f_p/f_s$. This type of amplifier is called an *upper-sideband (noninverting) upconverter*.

Now, let $f_1=f_s$ be the signal frequency but let power be supplied from the pump at the frequency $f_3=f_p$. Hence, $P_3=P_p>0$ and both $P_1=P_s<0$ and $P_2<0$; so the reactance can deliver energy at frequencies $f_1=f_s$ and $f_2=f_p-f_s$. If the power is extracted at the frequency f_2 , the device is called a *lower-sideband (inverting) upconverter*. The term *inverting* is used because the input signal spectrum is inverted at the output in this mode of operation.

If, as stated, the nonlinear capacitance is pumped at the frequency $f_3=f_p$, that is, $P_3=P_p>0$ and $P_1=P_s<0$ and $P_2<0$, but the output is at the frequency $f_1=f_s$, then the negative sign of P_1 indicates that the capacitor emits more power than that fed from the generator at $f_1=f_s$. It should be noted that the power supplied from the varactor to the signal source is independent of that supplied by the source itself; thus infinite gain is possible and the device is able to oscillate. It indicates that the pumped varactor presents a negative resistance to the signal source. Hence, with this frequency arrangement the signal power can be amplified at the same frequency, in contrast to the previous cases. The powers P_1 and P_2 are strongly dependent on the pump power and the external impedances. When the input and output frequencies are the same at $f_1=f_s$, power at $f_2=f_p-f_s$ is simply dissipated in the circuit and is unused. It justifies the name *idler* used traditionally for this frequency. The idler signal is an inevitable byproduct of this type of amplification, and suppressing it would also suppress the desired amplification of the signal. The separation of the idler and signal frequency is an important factor determining design and properties of this single-port (or *reflection* type) amplifier—the closer the idler to the signal, the more difficult it is to separate them by filtering. If the signal and idler frequencies are separated far enough so that the signal circuit does not pass the idler, the amplifier is called a

nondegenerate amplifier. In the opposite case, if the signal circuit passes both the signal and idler bands and the input termination is common to both, that is, $f_1 = f_p - f_s \approx f_s$, the amplifier is said to be *degenerate*.

VARIABLE DIODES

The most convenient nonlinear reactance element is a semiconductor diode specially designed to provide large variation of diode junction capacitance as a function of the applied (reverse) pumping voltage. Varactors may be classified into two broad groups, depending on the method of fabrication: the junction varactors, widely used at microwave frequencies, and the Schottky barrier varactors, generally used at millimeter waves and in high-performance amplifiers. Both groups are extensively discussed elsewhere in this encyclopedia, so only brief descriptions are given here and only problems specific for parametric amplifiers applications are discussed.

A typical junction varactor is made on an n-type silicon or gallium arsenide wafer, with a highly doped conducting substrate on which is grown a lower doped epitaxial layer. A suitable p-type dopant is then diffused into the epilayer to obtain p⁺ region and to form the p⁺-n junction. Ohmic contacts are made to a small circular area on the top of the wafer for the anode and to the bottom of the wafer for the cathode. Most of the epitaxial layer is then etched away, except the portion that is under the top contact. In this way a mesa of the desired diameter is formed. Diodes fabricated in this manner are called *diffused epitaxial varactors*.

A Schottky barrier varactor diode consists of a circular metallic contact pad (usually platinum) deposited on a lightly doped n-type layer epitaxially grown on a heavily doped GaAs substrate. The epitaxial layer is conductive except in the vicinity of the metal–semiconductor interface, where an insulating depletion zone is formed. Depletion-layer thickness, and thus the capacitance, varies with the biasing voltage applied to the metal–semiconductor junction.

Simple, but justified by relatively low operating frequencies, varactor models are used in the analysis and design of parametric amplifiers; the reader is referred to Ref. 14 for advanced modeling of varactor diodes. A typical equivalent circuit of a microwave varactor is shown in Fig. 3. The reverse-bias junction is modeled in this simple circuit by a voltage dependent capacitor $C_j(v)$ and series resistance R_s . The terms L_p , C_p , and C_s are linear parasitic inductance, capacitance, and stray capacitance, respectively. The dependence of the junction capacitance on the applied reverse voltage v is given by

$$C_j(v) = C_{j0} \left(1 - \frac{v}{\phi}\right)^{-\theta} \quad (3)$$

where ϕ is the barrier potential and C_{j0} is the zero-bias capacitance. The exponent θ depends on the doping profile of the epitaxial layer of the varactor. For Schottky diode varactors with uniform epitaxial layer doping, it is close to $\frac{1}{2}$. For p⁺-n-junction varactors the θ factor varies from $\frac{1}{3}$ for a linearly graded diffused junction up to $\frac{1}{2}$ for an ideal abrupt junction. Other doping profiles (e.g., hyperbolic) have also

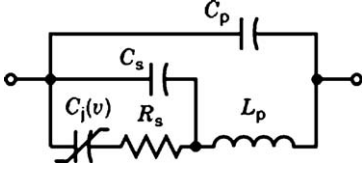

Figure 3. Equivalent circuit of a varactor. The reversed-bias junction is represented by a voltage-dependent capacitor $C_j(v)$ and a series resistance R_s . L_p , C_p , and C_s are parasitic inductance, capacitance, and stray capacitance, respectively.

been used in *hyperabrupt varactors* to obtain larger capacitance variation and thus higher values of the ∂ factor (∂ in excess of 1 have been reported). However, the performance of the parametric amplifier depends not only on the capacitance change ΔC_j but also on the series resistance R_s of the varactor. Unfortunately, hyperabrupt varactors have high series resistance ($\Delta C_j/R_s$ is lower than for other varactors), which excludes their use in high-performance amplifiers.

In Schottky barrier varactors the series resistance is dominated by the contribution from the undepleted epitaxial layer. For parametric amplifiers, a breakdown voltage of a few volts is sufficient and this allows relatively high doping and a thin epitaxial layer, thereby reducing the series resistance. In diffused epitaxial varactors there are additional sources of parasitic resistance, namely, the resistance of the diffused p^+ -region and the resistance of the ohmic top contact. The p^+ -region resistance becomes large at cryogenic temperatures, causing serious degradation of diode performance. Similarly, silicon diodes cannot be used in cooled amplifiers because of series resistance increase and carrier freezeout below 40 K (14). Hence gallium arsenide Schottky varactors have been the best choice for cooled parametric amplifier applications because of their low, relatively temperature-insensitive resistance.

Varactor Figures of Merit

Efficient varactor operations require the reactance of the junction capacitance to be much larger than the diode series resistance. It places an upper frequency limit on the usefulness of a given varactor, and figures of merit quantify this limit.

The static *cutoff frequency* f_c gives an indication of loss and is defined as that frequency at which the capacitive reactance of the junction at zero bias becomes equal to the series resistance:

$$f_c = \frac{1}{2\pi R_s C_{j0}} \quad (4)$$

For varactor applications the diode is characterized by the *dynamic cutoff frequency* defined as

$$f_{ed} = \frac{1}{2\pi R_s} \left(\frac{1}{C_{j,\min}} - \frac{1}{C_{j,\max}} \right) \quad (5)$$

where $C_{j,\min}$ and $C_{j,\max}$ are the values of C_j at the reverse breakdown voltage and at the zero bias voltage (or at $1 \mu\text{A}$ forward current), respectively.

Correspondingly, the quality factors at a specified frequency f_0 are given as $Q = f_c/f_0$ and for a pumped abrupt junction as $Q_d = 0.25 f_{ed}/f_0$.

In an amplifier, the capacitance is modulated by the application of microwave power at the pump frequency f_p and thus varies periodically in time. Hence $C_j(t)$ can be expanded into Fourier series

$$C_j(t) = C_0 \left(1 + \sum_{n=1}^{\infty} 2\gamma_n \cos 2\pi n f_p t \right) \quad (6)$$

where C_0 and γ_n are the Fourier coefficients. The values of γ_n , in particular that of γ_1 , determine parametric amplifier performance. In most practical cases higher terms may be ignored and only C_0 (the average value of the pumped capacitance) and γ_1 need to be considered. The diode capacitance *modulation coefficient* γ_1 is, of course, a function of the voltage developed across the diode at pump frequency, but will have a maximum attainable value, termed *nonlinearity factor*, given by

$$\gamma = \frac{C_{j,\max} - C_{j,\min}}{2(C_{j,\max} + C_{j,\min})} \quad (7)$$

When γ is referred to, it is usually this maximum value that is intended.

For parametric amplifier applications the most useful quantity to characterize the diode is the *pumped figure of merit*, defined as

$$M = \gamma f_{c0} \quad (8)$$

where

$$f_{c0} = \frac{1}{2\pi R_s C_0} \quad (9)$$

is the *pumped cutoff frequency*. A high pumped figure of merit indicates a low attainable noise of the amplifier.

NONDEGENERATE PARAMETRIC AMPLIFIER

As mentioned above, several three-frequency amplifier configurations are feasible. Of these, the negative-resistance nondegenerate parametric amplifier with a varactor diode providing a suitable nonlinear capacitance has achieved the most success as a practical low-noise paramp. A lumped-circuit analog of the microwave amplifier is used to obtain some insight into the operation of this type of amplifier. The model, shown in Fig. 4, consists of three resonant circuits coupled by a varactor that may be represented by the equivalent circuit of Fig. 3. So that the properties of the nonlinear element, rather than these of the resonant circuits, can be emphasized, it is assumed that the resonant circuits are ideal, and this is taken to mean that at certain frequencies they are pure resistances, while at all other frequencies they are very high impedances and, therefore, virtually open circuits.

With these assumptions, the behavior of the amplifier at the frequency $f_1 = f_s$ can be described in terms of a negative resistance \mathcal{R} (voltage developed across \mathcal{R} is out of phase of the current flowing through it), which appears in the equivalent circuit of the amplifier at this frequency. Its value is given by (1, 8)

$$\mathcal{R} = -\frac{\gamma^2}{\omega_s \omega_i R_{T1} C_0^2} \quad (10)$$

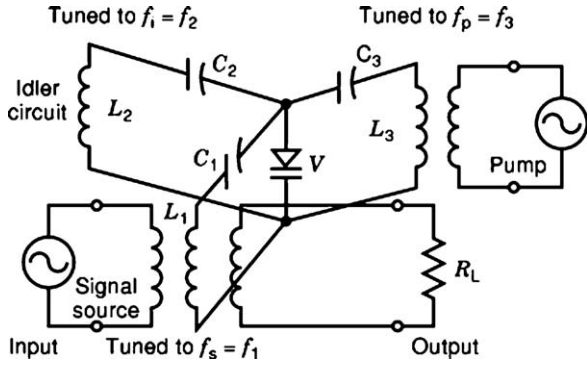

Figure 4. Lumped-element model of a microwave nondegenerate parametric amplifier. Three ideal resonant circuits tuned to signal, $f_s=f_1$, idler, $f_i=f_2$, and pump, $f_p=f_3$, frequencies are coupled by a varactor represented by the equivalent circuit of Fig. 3.

where $R_{T1}=R_s+R_2$ is the total series resistance at the idler frequency $f_i=f_2$.

The transducer power gain is taken as the ratio of power dissipated in the load resistance R_L to the available power from the signal source (internal resistance R_g) and is given by

$$G_p = \frac{4R_g R_L}{(R_g + R_L + R_s + \mathcal{R})^2} \quad (11)$$

clearly, for high gain $R_g+R_L+R_s \approx |\mathcal{R}|$.

In common with all other negative-resistance amplifiers, the negative-resistance parametric amplifier is extremely sensitive to small changes in the value of \mathcal{R} and changes in source and/or load resistance when it is operated under high-gain conditions. In practice \mathcal{R} may change as a result of fluctuations in the pump power and frequency, and control circuits have often been employed in conjunction with klystron pump sources in an effort to minimize such fluctuations. The popular approach was to control the attenuator in the pump line to maintain a constant varactor bias. Frequency fluctuations were handled in critical applications by locking the pump to a stable reference. The introduction of Gunn oscillators as pump sources resulted in a considerable improvement in stability, making stabilization schemes unnecessary in most cases (12).

Operation with a Circulator

Nonreciprocal devices such as circulators are used to separate the amplified output from the input and to protect the amplifier against changes in impedance at the input or at the following stage of the receiver. An ideal circulator is a circuit element that directs energy from one port to the next port without loss and prevents transmission in the opposite direction. This passive component obtains its nonreciprocity from the presence of a central ferrite structure placed in a DC magnetic field.

Early paramps used three-port circulators, but most recent designs incorporated five-port circulators to increase immunity from the effect of source impedance variation and to provide greater isolation between adjacent stages in multistage amplifiers. (For stability, the gain was usually limited to 20–25 dB for a single-stage device. If higher

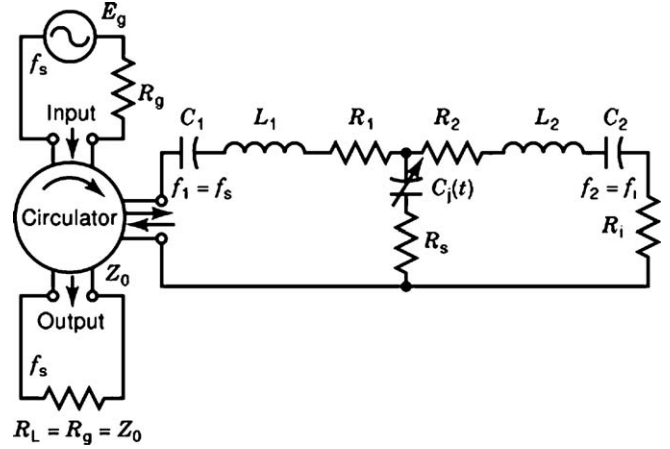

Figure 5. Equivalent circuit of the nondegenerate parametric amplifier employing a circulator to separate the amplified output from the input. The pumped varactor is represented by a capacitance $C_j(t)$ periodically varying in time and series resistance R_s .

gain was required, a number of 10–15-dB stages were connected in cascade.)

Knowing that the variation of the varactor's junction capacitance is completely controlled by the pump, it is then possible to concentrate entirely on that variation, and omit details of the source that produced it. The circuit of Fig. 4 can therefore be redrawn as in Fig. 5, leaving out the pump circuit; the capacitance is then specified as $C_j(t)$, emphasizing in this way the time variation. The signal source and the load are connected to the amplifier via a three-port circulator.

Power Gain. The power gain of the amplifier–circulator combination can be seen to depend on the ratio of the powers entering and leaving the amplifier. Since the circulator has a characteristic impedance Z_0 to which it should be matched, source and load resistances will have the same value, and the circuit available gain will equal the transducer gain. The required power gain is therefore equal to the square of the magnitude of the voltage reflection coefficient Γ and, since $R_g=R_L=Z_0$, is given by

$$G_p = \Gamma\Gamma^* = \left| \frac{R_s + R_L - \mathcal{R}}{R_s + R_L + \mathcal{R}} \right|^2 \quad (12)$$

With the use of a circulator, the input loop of the amplifier effectively contains only one of two resistors, R_g or R_L . For high gain, that is, $R_L+R_s \approx |\mathcal{R}|$, Eq. (12) can be rewritten as

$$G_p = \frac{4R_L^2}{(R_L + R_s + \mathcal{R})^2} \quad (13)$$

Comparing the expressions for power gain with and without the circulator (setting $R_g=R_L$ and remembering that $R_s \gg R_L$), it can be seen that the use of a circulator has increased the power gain 4 times for the same gain stability, where instability of gain results from changes in \mathcal{R} .

Noise Temperature. In low-noise amplifiers, it is more convenient to express noise performance in terms of *effective noise temperature* (or, in short, *noise temperature*),

which is related to the noise figure F by the equation

$$T_e = T_0(F - 1) \quad (14)$$

where $T_0=290$ K is a standard temperature.

The effective noise temperature of the parametric amplifier depends on the thermal noise contributions from all the resistances in the circuit (shot noise is not present in the reverse-biased junction). Neglecting contributions other than that from the varactor itself, the noise temperature of a negative-resistance reflection-type parametric amplifier can be calculated in this limiting case from the following equation (5–8)

$$T_{ea} = T \left(1 - \frac{1}{G_p} \right) \frac{\left(\frac{f_{c0}}{f_1} \right)^2 \gamma^2 + 1}{\frac{f_{c0}^2}{f_s f_1} \gamma^2 - 1} \quad (15)$$

where T is the diode physical temperature and G_p is the amplifier power gain. It is possible to calculate the pump frequency $f_{p,opt}$ at which the parametric amplifier noise temperature has its minimum value. This is given by

$$f_{p,opt} = f_s \left[1 + \left(\frac{f_{c0}}{f_s} \right)^2 \gamma^2 \right]^{1/2} \approx \gamma f_{c0} = M \quad (16)$$

and the optimum noise temperature for large gain becomes

$$T_{ea,opt} = T \frac{2 f_s}{\gamma f_{c0}} = \frac{2 f_s T}{M} \quad (17)$$

Thus, it is apparent that for good amplifier performance a diode should combine high cutoff frequency with a marked capacitance variation, even at low temperatures, in order to achieve low noise temperature.

If we now add contributions from losses in the signal and idler circuits, the circuit behavior of the circulator-type amplifier (where $R_1=R_g$), is then described by the noise temperature

$$T_{ea} = \frac{T_1 R_1}{R_g} + \frac{T_d R_s}{R_g} + \frac{f_s |\mathcal{R}|}{f_i R_g} \left[\frac{T_d R_s + T_2 R_2}{R_2 + R_s} \right] \quad (18)$$

where \mathcal{R} is the negative resistance given by Eq. (10), R_g is the generator resistance in the signal circuit and R_1 and R_2 represent losses (other than R_s) in signal, $f_1=f_s$, and idler, $f_i=f_2$, circuits. T_1 , T_2 , and T_d are the temperatures of R_1 , R_2 , and R_s , respectively. In practical amplifiers temperatures are usually equal, that is, $T_1=T_2=T_d=T$ and the amplifier is designed to have, as far as possible, R_1 and R_2 negligibly small in comparison with R_s . Then, at high gain, that is, $|\mathcal{R}|$, the noise temperature is given by

$$T_{ea} = T \left(\frac{R_g + R_s}{R_g} \frac{f_p}{f_i} - 1 \right) \quad (19)$$

For many applications cooling is not necessary. Adequate low-noise performance can be achieved using simple circuits with diode of moderate cutoff frequency. If lower noise temperatures are required, it is necessary to use higher idler frequencies, and this is possible only if a diode of sufficiently high cutoff frequency is used. When cooling is necessary to lower the noise temperature, it must be remembered that any loss in the path between the signal source, such as an antenna, and the parametric amplifier may considerably degrade the overall noise temperature. If the loss

of the circulator is $A=10 \log(L)$, then the noise temperature of the circulator–amplifier cascade is calculated from

$$T_{e,c-a} = T_{e1} + \frac{T_{e2}}{G_1} = (L - 1)T + LT_{ea} \quad (20)$$

If, for example, a circulator with $A=0.41$ dB transmission loss is ahead of a low-noise, $T_e=100$ -K amplifier, then at room temperature, $T=290$ K, the receiver has noise temperature $T_{e,c-a}=0.1 T+1.1 T_{ea}=139$ K. When the amplifier is cooled down to temperature 20 K, its noise temperature lowers to, say, $T_{ea}=10$ K. Leaving the circulator uncooled will increase the overall noise temperature 4 times to $T_{e,c-a}=40$ K. It is thus obvious that both the circulator and the amplifier must be cooled down to obtain low-noise performance of the receiver ($T_{e,c-a}=13$ K in this illustrative example).

Bandwidth. Much effort has been spent in devising ways of obtaining the broad bandwidth essential in some applications—see Ref. 9 for a thorough review of advanced techniques used for the purpose. Because the bandwidth of an amplifier depends on its gain (decreases with increase of gain), the gain–bandwidth product is used to characterize the amplifier performance. It can be shown (8) that for a negative-resistance amplifier operated in conjunction with a circulator, the gain–bandwidth product may be derived as

$$G_p^{1/2} B = 2 \left(\frac{1}{B_s} + \frac{1}{B_i} \right)^{-1} \quad (21)$$

where B_s and B_i are the unpumped signal and idler circuit bandwidths, respectively. Both signal and idler circuits should therefore be as broadband as possible to give the amplifier a good gain–bandwidth product.

Since the signal circuit is loaded externally by the source resistance, whereas the idler has no external loading, the latter will tend to be a high- Q circuit limiting the bandwidth. The resistance present in the idler has already been fixed at the diode resistance R_s , and any increase in this will degrade the amplifier performance. Therefore, in order to optimize the bandwidth of the idler circuit, it is necessary to keep the reactance of the idler circuit as low as possible. (The bandwidth of a series-tuned circuit is given by the R/L ratio.) This can be achieved by confining the idler power to the varactor encapsulation. From Fig. 3 it can be seen that there is the possibility of a series resonance, associated with L_p , C_0 (the average value of the pumped junction's capacitance), C_s , and R_s at the frequency given by

$$\omega_{si}^2 \approx \frac{1}{L_p(C_0 + C_s)} \quad (22)$$

neglecting the effect of R_s . The resonant frequency f_{si} can be arranged to be the idler frequency of the amplifier, but in order to use the series resonance in this way, a return path for the current must be provided (e.g., by a lumped circuit or a length of transmission line). An elegant solution to this problem uses two antiparallel connected diodes. When sufficiently excited, the idler current will circulate around this structure and will not propagate to any other part of the amplifier. A further development of this idea has seen

the production of suitable diodes in one encapsulation. Another approach is to mount the diodes back to back across the pump waveguide with signal line entering through the sidewall and contacting the junction between them (cross-bar configuration).

For parametric amplifiers with a high idler frequency it is more convenient to use the parallel resonance of the encapsulated diode (which is actually a series resonance for the idler currents) to form the idler circuit. Such an amplifier uses a single diode and can be further refined by modifying the series resonance to support the signal frequency.

Careful attention to the design of the idler circuit leaves the bandwidth of the signal circuit as the main limitation on the overall bandwidth of the parametric amplifier. An estimate of the maximum attainable bandwidth under these conditions may be made putting $B_i \ll B_s$ in Eq. (21) to yield

$$G_p^{1/2} B \simeq 2B_s \quad (23)$$

If the signal circuit is now designed for the minimum possible Q-factor associated with the source resistance, then the added inductance must just resonate the diode capacitance at the signal frequency (i.e., single-tuned circuit). Then under the high-gain condition, it is found that

$$G_p^{1/2} B \simeq 2\gamma f_s \left(\frac{\gamma f_{c0}}{f_p - f_s} \right) = 2\gamma^2 f_{c0} \frac{f_s}{f_i} \quad (24)$$

The result suggests that high-quality diodes are important in securing large gain–bandwidth products, and that there must be a tradeoff between effective noise temperature and bandwidth in selecting the pump and, therefore, the idler frequency.

Considerable improvement in the overall gain–bandwidth product can be achieved by introducing a filter structure in place of a simple single resonant circuit. Improvements of over 5 times have been reported with little increase of noise temperature. For a maximally flat design, the limiting bandwidth should be given by $B \log(G_p) = \text{const}$, but in practice the use of more than two or three compensating elements leads to practical difficulties in tuning the device.

OTHER PARAMETRIC AMPLIFIER CONFIGURATIONS

Degenerate Parametric Amplifiers

In the degenerate parametric amplifier, the pump frequency is approximately twice the signal frequency. The signal and idler passbands overlap, and instead of idler circuit being terminated inside the amplifier, it is effectively terminated in the input of the amplifier. The absence of a separate idler circuit makes construction of such an amplifier much simpler than the corresponding nondegenerate version. The additional advantages are a low pump frequency and a wider bandwidth. Therefore, degenerate amplifiers were finding applications in some early broadband radiometers and more recently in millimeter-wave paramps.

The phase-coherent degenerate amplifier in which the pump frequency is exactly twice the signal frequency is

by its nature a single-frequency device since no departure from coherence with the pump is allowed (1,4,8). To achieve the required frequency relationship, in practice it would be necessary to synchronize the pump frequency to the second harmonic of the signal frequency with special phase-locked loop (PLL) circuitry. It can be shown (1) that the gain of the amplifier changes with changes in phase of the pump signal, rendering the use of this amplifier impracticable in the majority of potential applications.

Even if phase relations are loosened and the signal frequency is only approximately equal to the idler frequency, care must be taken in using the amplifier. It should be noted that the degenerate amplifier is not suitable for direct use with frequency-modulated signals, since when f_s increases in frequency, then $f_i = f_p - f_s$, which is present at the same terminals, decreases in frequency. The signal fed into a degenerate amplifier may be amplitude-modulated, although if the amplifier has the idler frequency only approximately equal to the signal frequency, beats between the two waveforms can cause interference. A cascade of the degenerate paramp followed by a parametric converter pumped synchronously at $0.5f_p$ was used to overcome both difficulties (1).

The major disadvantage of degenerate amplifiers becomes apparent when we consider that a signal entering receiver appears in both idler and signal responses of the amplifier and the output contains both the signal and its image (also noise from both responses adds at the amplifier output). When coherent communication signals are involved, this double response is unacceptable. In radiometer applications, where the signal takes the form of broadband noise, this type of amplifier has good sensitivity, since the signal is received equally in both the signal and idler bands. In general, the use of degenerate amplifier must be judged carefully considering the nature of the signal, single- or double-sideband operation at the input and the output of the amplifier, and the nature of the detector employed in the receiver. A detailed discussion of this subject can be found in Refs. 4, 10, and 11.

Multiple-Idler Parametric Amplifiers

To circumvent some of the disadvantages of the three-frequency paramps, many other frequency combinations had been proposed for parametric amplifiers in the hope that an improved performance would outweigh the disadvantages of (usually) increased complexity. If more than one idler frequency is used, it is possible to use a pump frequency lower than the signal frequency. In the 2-idler case (the so called four-frequency paramp), the usual restriction

$$f_1 = f_p - f_s > 0 \quad (25)$$

is replaced by

$$f_{i1} = f_s - f_p > 0 \quad (26)$$

for the first idler, and

$$f_{i2} = (f_p - f_{i1}) = 2f_p - f_s > 0 \quad (27)$$

for the second idler. Therefore $\frac{1}{2} f_s < f_p < f_s$ is required for efficient operation (negative resistance at signal frequencies $f_p < f_s < 2f_p$). Note that if f_p is chosen as $\frac{1}{2} f_s$,

then the two idler frequencies will both be equal to $\frac{1}{3} f_s$. The lack of adequate pump generators was the main reason to use four-frequency paramps at millimeter waves. However, more complex microwave construction usually resulted in higher losses and hence poor noise performance and, therefore, multiple-idler paramps found only limited applications (9).

Traveling-Wave Parametric Amplifier

Up to now parametric devices utilizing essentially resonant structures have been considered. Such circuits suffer from previously discussed drawbacks; some of them can be minimized by resorting to nonresonant propagating circuits. A variety of configurations are possible, each with its own characteristics. Perhaps the simplest is the case where all the three traveling waves—signal, idler, and pump—have positive phase and group velocities. This was exploited in amplifiers taking the form of a transmission line periodically loaded with varactor diodes. It was difficult in practice to satisfy phase requirements for all the signals, and some experimental amplifiers provided separate pump feeds for each diode (10). For frequencies below 1.5 GHz, experimental amplifiers had usually the form of stripline with diodes between the central and outer conductors (1, 7). For higher frequencies, the diodes were mounted across rectangular waveguide or a series of coupled cavities (10).

In practice, because of the difficulties of providing a considerable number of identical diodes and the experimental difficulties of providing the correct phase characteristics at the three frequencies, the performance of traveling-wave amplifiers was worse than that achieved with much more simple and requiring much less pump power single-diode devices. Therefore, traveling-wave parametric amplifiers have never been developed beyond the experimental stage and have never left the laboratory. A distributed varactor was needed for success in this field. However, it appeared at the end of the 1970s in a form of nonlinear transmission line employing distributed Schottky barrier varactors (14). It was too late—parametric amplifiers were just giving way to new technology of GaAs field-effect transistor amplifiers.

ILLUSTRATIVE EXAMPLE

There were many species of microwave parametric amplifiers, and a wide range of amplifiers design were available (see Refs. 4–6, and 9–11 for detailed and complete design theories and practical considerations). The choice was dependent on the particular application. In many applications, the lower limit of background noise in the system was determined by thermal noise entering the antenna from the terrestrial surroundings, and for such applications relatively simple uncooled parametric amplifiers were commercially available. For reception of the weak signals from communication satellites or interplanetary probes, however, extremely low system noise temperature was essential and a whole range of specialized cooled amplifiers was developed offering noise temperatures as low as 12–15 K (comparable with masers).

Bandwidth and operating frequency requirements were widely diversified. Paramps were made to amplify signals up to the millimeter-wave frequencies (60-GHz paramps are reported in Ref. 9). For some terrestrial communication and radar requirements, paramps with a low MHz bandwidth were routinely manufactured. Satellite communication systems required 500 MHz bandwidth, and specially designed paramps were developed for such systems.

A 3.25-MHz nondegenerate parametric amplifier (12) has been selected as a representative example to illustrate the elegant design and refinement of microwave construction. The amplifier designed for spectral line radio astronomy covers the frequency range 3.1–3.4 GHz with an instantaneous bandwidth of 40 MHz. A section drawing of the amplifier is shown in Fig. 6. Description of the amplifier is rewritten here with permission of John Wiley & Sons, Inc.:

The varactor diode is mounted in the E -plane of a reduced-height waveguide which couples pump power from a 22 GHz reflex klystron to the varactor. A short length of high-impedance coaxial line series resonates the diode mean capacitance at the signal frequency. A three-element low-pass filter isolates the pump and idler from the input line while the pump waveguide is cut off at the idler frequency, confining the idler to the vicinity of the varactor and the idler cavity. The idler circuit contains a tunable cavity coupled to the varactor by an iris. The position of this iris was chosen to optimize the pump coupling to the varactor. The idler frequency is determined by the combination of the package parasitic reactances, the coupling, and the tunable cavity, which consists of a micrometer-adjustable noncontacting short circuit in a cylindrical tube. The pump and idler blocking filter forms part of a quarter-wave Transformer in the input coaxial line, which is used to transform the characteristic impedance of an external circulator to the value required to obtain a desired gain [R_L in Eq. (13)]. No external bias is provided, the varactor being pumped until self-bias is developed.

The amplifier gain was set to 20 dB and, from noise measurements of uncooled receiver, its effective noise temperature was estimated to be 60 K.

BIBLIOGRAPHY

1. L. A. Blackwell and K. L. Kotzebue, *Semiconductor-Diode Parametric Amplifiers*, Prentice-Hall, Englewood Cliffs, NJ, 1961.
2. B. W. Siergowancew, *Microwave Parametric Amplifiers* (in Russian), Sowietskoje Radio, Moscow, 1961.
3. A. P. Bielousow, *Parametric Amplifiers with Varactor Diodes* (in Russian), Oborongiz, Moscow, 1961.
4. P. Penfield, Jr. and R. P. Rafuse, *Varactor Applications*, MIT Press, Cambridge, MA, 1962.
5. M. Uenohara, Cooled varactor parametric amplifiers, in L. Young, ed., *Advances in Microwaves*, Academic Press, New York, 1967, Vol. 2.

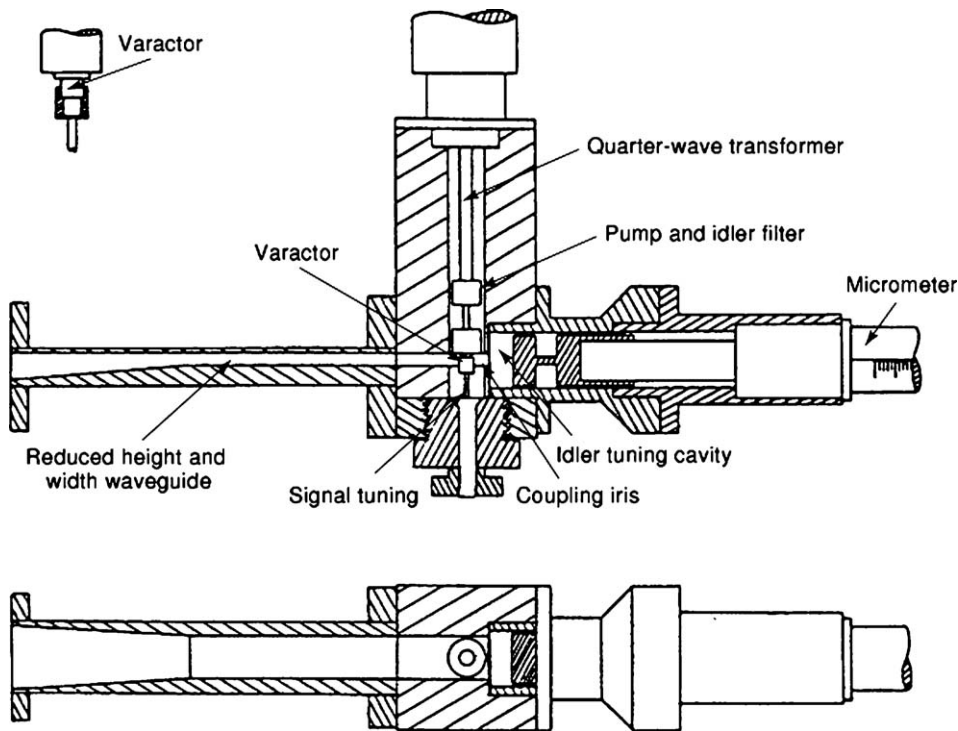

Figure 6. Representative example of the microwave construction of a parametric amplifier: section diagram of a 3.25-GHz nondegenerate parametric amplifier. (Source: J. W. Archer and R. Batchelor, Multipliers and parametric devices, in K. Chang, ed., *Handbook of Microwave and Optical Components*, Vol. 2, p. 187. ©1990 John Wiley & Sons. Reprinted by permission of John Wiley & Sons, Inc.)

6. M. Uenohara and J. W. Gewartowski, Varactor applications, in H. A. Watson, ed., *Microwave Semiconductor Devices and Their Circuit Applications*, McGraw-Hill, New York, 1969.
7. H. N. Daghish, J. G. Armstrong, J. C. Walling, and C. A. P. Foxell, *Low-Noise Microwave Amplifiers*, Cambridge Univ. Press, Cambridge, UK, 1968.
8. D. P. Howson and R. B. Smith, *Parametric Amplifiers*, McGraw-Hill, London, 1970.
9. C. L. Cuccia, Ultralow-noise parametric amplifiers in communication satellite earth terminals, in L. Young, ed., *Advances in Microwaves*, Academic Press, New York, 1971, Vol. 7.
10. K. St. Grabowski, *Parametric Amplifiers and Mixers with Varactor Diodes* (in Polish), Wydawnictwa Naukowo-Techniczne, Warsaw, 1968.
11. J. C. Decroly, L. Laurent, J. C. Lienard, G. Marechal, and J. Vorobeitchik, *Parametric Amplifiers*, Macmillan, London, 1973.
12. J. W. Archer and R. A. Batchelor, Multipliers and parametric devices, in K. Chang, ed., *Handbook of Microwave and Optical Components*, Wiley, New York, 1990, Vol. 2.
13. S. Weinreb, M. W. Pospieszalski, and R. Norrod, Cryogenic, HEMT, low-noise receivers for 1.3 to 43 GHz range, *IEEE MTT-S Int. Microwave Symp. Digest*, 1988, pp. 945–948.
14. M. T. Faber, J. Chramiec, and M. E. Adamski, *Microwave and Millimeter-Wave Diode Frequency Multipliers*, Artech House, Boston–London, 1995.
15. A. Khanifar, R. J. Green, A. Khosrowbeygi, N. T. Ali, and M. Milovanovic, The analysis of photoparametric amplifying devices and characteristics, *IEEE MTT-S Int. Microwave Symp. Digest*, 1995, pp. 1503–1506.
16. J. -C. Lee, H. F. Taylor, and K. Chang, Degenerate parametric amplification in an optoelectronic GaAs CPW-to-slotline ring resonator, *IEEE Microwave Guided Wave Lett.* **7**(9): 267–269 (1997) .
17. H. V. Shurmer, *Microwave Semiconductor Devices*, Pitman Publishing, London, 1971.

Further Reading

- S. Okwit, An historical view of the evolution of low-noise concepts and techniques, *IEEE Trans. Microwave Theory Tech.* **MTT-32**(9): 1068–1082 (1984) .
- M. E. Hines, The virtues of nonlinearity—detection, frequency conversion, parametric amplification and harmonic generation, *IEEE Trans. Microwave Theory Tech.* **MTT-32**(9): 1097–1104 (1984) .
- D. G. Tucker, *Circuits with Periodically-Varying Parameters*, Macdonald, London, 1964.
- S. A. Maas, *Nonlinear Microwave and RF Circuits*, 2nd ed., Artech House, Boston–London, 2003.
- S. Yngvesson, *Microwave Semiconductor Devices*, Kluwer, Boston, 1991.
- S. A. Maas, *Microwave Mixers*. 2nd ed., Artech House, Boston–London, 1993.

MAREK T. FABER
 Warsaw University of
 Technology , Warsaw, Poland