

Figure 2. Typical isolator applications: (a) isolating transmitter from antenna, (b) isolating two stages of an amplifier, and (c) isolating local oscillator from mixer.

MICROWAVE ISOLATORS

Isolators are used extensively in microwave equipment to prevent interaction between other components of the system. This article describes the principles of operation of the most common types of microwave isolators and typical operating characteristics of these isolators. In addition, references are provided for further information on the theory of operation and design details.

An isolator is a two-port device that has low insertion loss from port 1 to port 2 and high insertion loss from port 2 to port 1, as shown schematically in Fig. 1. An ideal isolator is represented by the following scattering matrix, which indicates that ideally the device is also perfectly matched at the input and output ports:

$$S = \begin{bmatrix} 0 & 0 \\ S_{21} & 0 \end{bmatrix} \quad \text{where } |S_{21}| = 1 \quad (1)$$

Isolators find wide application in microwave systems eliminating interactions between components, for instance, as in Fig. 2(a), between a transmitter's power amplifier and an antenna. The output from the amplifier is transmitted with low loss to the antenna, but energy reflected from the antenna is absorbed by the isolator. Other typical applications are to reduce interaction between stages of amplification [Fig. 2(b)] or between a local oscillator and a mixer [Fig. 2(c)].

An ideal isolator would have no insertion loss in the forward direction, infinite loss in the reverse direction, and a perfect match at the input and output. It would maintain these characteristics over a wide frequency range and would be able to handle high power signals in both the forward and reverse directions without limiting or distorting the signal by generating nonlinear intermodulation products. Practical, commercially available isolators typically are expected to have less than 0.5 dB insertion loss in the forward direction, greater than 20 dB loss in the reverse direction, and return loss of the input and output ports greater than 20 dB over

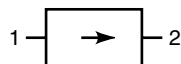

Figure 1. Schematic representation of an isolator.

frequency bandwidths up to an octave. If the isolator must operate over a wider frequency range, some sacrifice in insertion loss and isolation performance must be expected. Conversely, better performance may be required for some applications and is obtainable over narrow bands.

In a typical application illustrated in Fig. 3, the effect of the less-than-ideal characteristics of the actual isolator would be analyzed by considering the reflection at port *b* resulting from the mismatch between the load and the output impedance of the isolator. This reflected signal is then attenuated by the isolation of the isolator, and the resulting signal at port *a* is added vectorily to the reflection resulting from the mismatch between the source impedance and the input impedance of the perfectly terminated isolator. For example, if the isolator has an insertion loss of 0.5 dB, isolation of 20 dB, and an input and output return loss of 20 dB and the signal at port *b* is totally reflected back to the isolator, the reflected signal returning to the input port will be 20.5 dB below the incident signal and will be added vectorily to the reflection resulting from the input port mismatch, which is 20 dB down from the incident signal. The resulting total return loss will be between 14.2 and 45 dB depending on the relative phases.

Microwave isolators make use of the nonreciprocal microwave properties of a ferrite material biased by an applied direct current (DC) magnetic field. Of the many different approaches that have been devised to use these properties to form practical devices, most are included in the following general categories:

1. Terminated circulators
2. Faraday rotation isolators

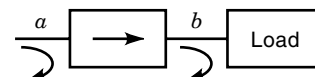

Figure 3. The total reflected signal at *a* is the vectorial sum of the reflection resulting from the mismatch of port *a* plus the signal reflected at *b* reduced by the isolation of the isolator.

- 3. Resonance isolators
- 4. Field displacement isolators

All these isolators differ from the ideal. In evaluating these different types of isolators, important characteristics that must be considered are forward and reverse insertion loss and the frequency bandwidth over which those values are obtained as well as the power handling capability. Some approaches are more applicable to some frequency ranges than others, and they differ in their applicability to different transmission media such as waveguide, coaxial line, or microstrip.

The following discussions describe the operation of these different types of isolators and compare their characteristics.

TERMINATED CIRCULATORS

Microwave circulators are described in detail in another article of this encyclopedia and are devices with three or more ports with low loss, for example, from port 1 to 2, 2 to 3, and 3 to 1 as illustrated in Fig. 4(a). Ideally they are lossless and are described by

$$S = \begin{bmatrix} 0 & 0 & S_{13} \\ S_{21} & 0 & 0 \\ 0 & S_{32} & 0 \end{bmatrix} \quad \text{where } |S_{13}| = |S_{21}| = |S_{32}| = 1 \tag{2}$$

Terminating port 3 of a three-port circulator [Fig. 4(b)] in a matched load results in an isolator between ports 1 and 2. The isolation depends on the match between the termination and port 3 of the circulator.

The circulator may be constructed in any of the many forms described elsewhere, such as waveguide, stripline, microstrip, or lumped-constant, and at frequencies from UHF to millimeter wavelengths. In addition to being compatible with the wide variety of transmission media, the terminated circulator approach has a significant advantage over other types

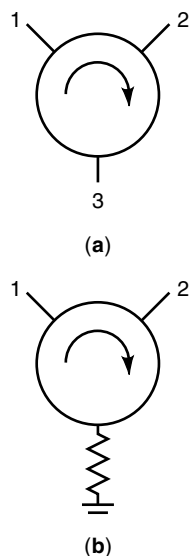

Figure 4. Connecting a matched load to port 3 of a three-port circulator forms a two-port isolator.

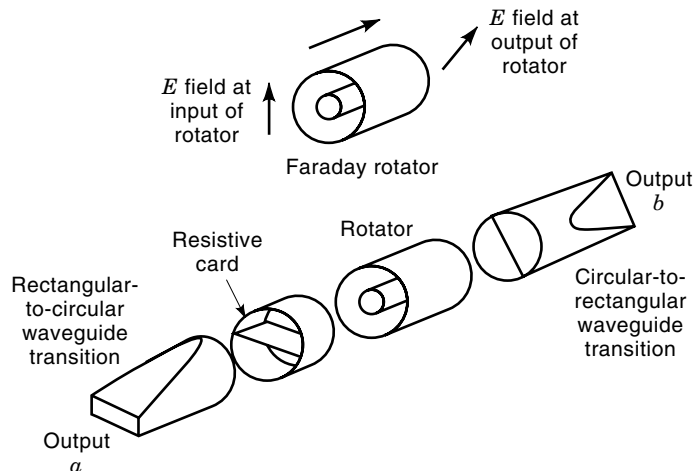

Figure 5. A Faraday rotation isolator.

of isolators in that the nonreciprocal function performed by the circulator is entirely separated from the problem of dissipating the energy of the signal propagating in the reverse direction. Thus, in applications where a large amount of reverse power must be dissipated, a high power load, with external cooling if necessary, can be provided; or in low power applications, a miniature termination such as a chip resistor can be integrated with the circulator to form a compact device.

The successful development of junction circulators in many forms and over a wide frequency range has resulted in the terminated circulator being the most common type of ferrite isolator.

FARADAY ROTATION ISOLATOR

The Faraday rotation isolator (1) was one of the first types of microwave ferrite devices. Its operation can be described with reference to Fig. 5. The Faraday rotator section consists of a ferrite rod at the center of a circular waveguide with its axis parallel to that of the waveguide. A dc magnetic bias field is applied along the axis of the ferrite rod. It is a property of the Faraday rotator that, if the input to the rotator section is a signal in the TE₁₁ mode of circular waveguide, the orientation of the E field will rotate as the signal propagates through the rotator as shown. This Faraday rotation can be demonstrated theoretically by considering the linearly polarized field in the circular waveguide section to be composed of two counterrotating circularly polarized modes. The magnetized ferrite can be shown to present a different microwave permeability to the two counterrotating modes, which therefore propagate with different velocities, resulting in the rotation of the total field pattern (2).

To make an isolator from this Faraday rotator, rectangular-to-circular waveguide transitions are placed at the input and output with matching provided to the ferrite-loaded section. Resistive cards are placed across the circular sections of the guide at both the input and output. An incoming signal from port *a* will go through the rectangular-to-circular waveguide transition transforming to the TE₁₁ mode in the circular guide with the E field perpendicular to the resistive absorber. Thus the signal is transformed with low loss to the ferrite-

loaded section. The ferrite-loaded portion of the guide is terminated at the point where the E field has been rotated by 45° , where it passes another resistive absorber oriented perpendicular to the E field and enters the transition back to the rectangular guide. Thus, the signal passes with low loss to the output port b .

On the other hand, if a signal is applied to port b , it again passes with low loss to the ferrite-loaded section where it is rotated so that at port a it is oriented with the E field parallel to the resistive absorber. The signal is then attenuated by the absorber.

The Faraday rotation isolator was one of the first microwave ferrite devices to be introduced, but it suffers from several performance limitations. The rotation in the basic device of Fig. 5 is frequency-dependent so the isolator is narrow band. In addition, the rotator is inherently a low-power device because of its geometry. The ferrite and the absorber are thermally isolated so that the power that can be handled, especially in the reverse direction, is limited. Techniques have been developed to increase the bandwidth over that of the basic device (2,3). For example, dielectric loading, ridged waveguide, and cascading of stagger-tuned sections have been used to produce acceptable performance over bandwidths of several gigahertz at X band, but because of its limitations the Faraday rotator has largely been superseded by the other isolator approaches discussed here.

One version of the Faraday rotation isolator that still finds application was described by Barnes (4). In this approach, instead of using a circular waveguide loaded by a ferrite rod, the conducting waveguide walls are eliminated, and the ferrite rod is increased in diameter so that the ferrite becomes a dielectric waveguide. The high dielectric constant (typically between 12 and 15) of the relatively large ferrite rod confines most of the energy to the ferrite.

The details of this type of isolator are described in detail by Barnes (4). The rotator consists of a short length of ferrite rod suspended in a nonconducting housing by plastic supports and is coupled to the input and output rectangular waveguides by dielectric tapers that protrude into the waveguides. The attenuator films that provide the reverse loss are deposited metal films sandwiched into the tapered dielectric waveguides.

Barnes shows that, because the dielectric rod guide with approximately 95% of the energy confined to the ferrite behaves much like an infinite ferrite medium, the Faraday rotation is less dependent on frequency than in a ferrite-loaded metal waveguide. Figure 6 shows the performance reported by Barnes for a 50 to 60 GHz isolator, along with the performance of a "conventional" Faraday rotation isolator. Because of its broadband performance and low magnetic bias field requirement, this approach has proved to be useful for broadband millimeter wavelength isolators.

RESONANCE ISOLATORS

The resonance isolator makes direct use of the phenomenon of ferromagnetic resonance, characterized by the precession of the magnetization vector in a ferrite about the direction of an applied dc bias field (2). In an unperturbed state, the direction of the magnetization vector of the ferrite is aligned with an applied bias field. Any disturbance, such as a momentary

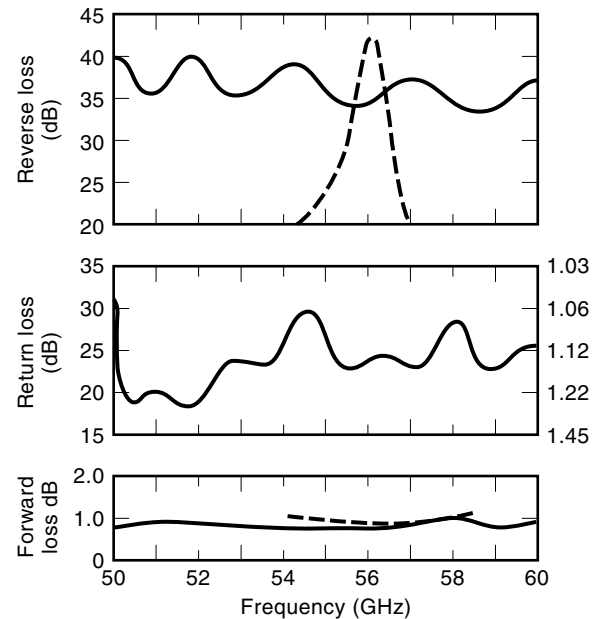

Figure 6. Performance of the broadband isolator of Barnes (solid curves) compared with a "conventional" Faraday rotation isolator (dashed curves) (4). Copyright © 1961 IEEE.

magnetic field applied perpendicular to the bias field, will cause the magnetization to precess about the direction of the bias field, as illustrated in Fig. 7. After the perturbation is removed, the precession will decay at a rate that depends on the magnetic losses of the material, until the magnetization is again aligned with the dc field.

The frequency of the precession, the ferromagnetic resonance frequency, is proportional to the dc field. In an infinite ferrite medium,

$$f_0 = \gamma H_{dc} \quad (3)$$

where, in the commonly used units, γ is 2.8 MHz/oersted. In the case of a finite ferrite element such as a plate or rod, the demagnetizing factor of the sample must be taken into account to relate the applied bias field to the internal field that determines the resonant frequency. For readily achievable magnetic fields, this resonant frequency is in the microwave region. Microwave signals near the resonant frequency with magnetic fields perpendicular to the bias field will interact strongly with the ferrite magnetization. In particular, circularly polarized fields in the plane perpendicular to the bias

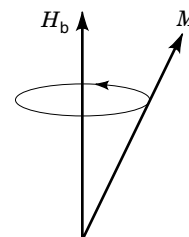

Figure 7. When perturbed from the steady state, the magnetization M will precess about the bias field H_b at the ferromagnetic resonant frequency.

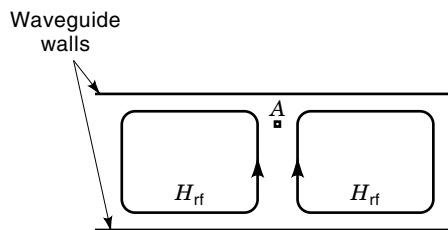

Figure 8. At point A the RF magnetic field for a signal traveling from left to right in the fundamental mode of the rectangular waveguide will be circularly polarized in the counterclockwise direction.

field will interact strongly if the sense of polarization corresponds to the direction of the resonant precession but only weakly if the sense of circular polarization is opposite to the direction of the precession.

Now consider a rectangular waveguide operating in the fundamental TE_{10} mode. Figure 8 shows the magnetic field of this mode, looking down on the broad face of the guide. At point A in the guide, the magnetic field will be circularly polarized in the counterclockwise direction for a signal traveling from left to right and in a clockwise direction for a signal traveling from right to left. If a ferrite is placed in the waveguide at this point and biased by a dc field, as shown in Fig. 9, the ferrite will interact strongly with a signal in the waveguide with a frequency near the ferromagnetic resonant frequency when the direction of propagation is such that the sense of circular polarization corresponds to direction of the ferromagnetic precession. The interaction will be weak for a signal traveling in the opposite direction. By proper design, the parameters such as the dimension and location of the ferrite, ferrite material properties, and bias field can be chosen so that, at frequencies near the ferromagnetic resonance frequency, excellent isolator performance can be achieved.

In principal resonance isolators can be constructed in any transmission line where circularly polarized radio-frequency (RF) magnetic fields exist. For example, they have been built with various degrees of success in dielectric-loaded coaxial line, fin line, dielectric waveguide, and image line; however, by far the largest application of the resonance isolator approach is in rectangular and ridged waveguide where extensive analysis and optimization has resulted in devices with very attractive properties.

Of the possible geometries illustrated in Fig. 10, Fig. 10(b) has demonstrated advantages over Fig. 10(a). Placing the ferrite in a thin strip along the broad waveguide wall allows efficient dissipation of the heat produced in high power operation. In addition, the magnetic fields are more nearly circu-

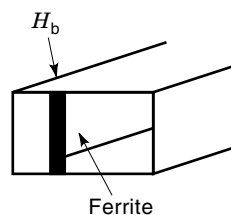

Figure 9. In this basic resonance isolator, the ferrite will interact strongly with a signal in one direction but not with one in the opposite direction.

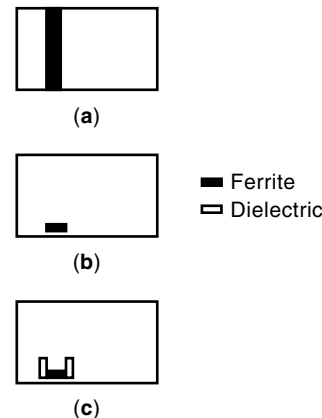

Figure 10. Three different configurations for a resonance isolator in rectangular waveguide.

larly polarized in the configuration of Fig. 10(b) than in Fig. 10(a) and experiments by Weiss (5) have shown Fig. 10(b) to have a superior ratio of isolation to forward insertion loss. This ratio of isolation to forward insertion loss is a Figure of Merit used to compare different isolator configurations. The Figure of Merit for Fig. 10(b) was determined by Weiss to be 75 compared with 14 for Fig. 10(a). Further improvement can be achieved with dielectric loading as illustrated in Fig. 10(c). The dielectric concentrates the energy in the vicinity of the ferrite and increases the Figure of Merit to 150.

Resonance isolators in rectangular waveguide have been developed to give good performance over a full waveguide bandwidth (for instance, 30 dB isolation, 1 dB forward loss, and 1.15 VSWR over 8.2 to 12.4 GHz, or 12.4 to 18 GHz).

Such resonance isolators are large and heavy because of the permanent magnets required to bias the ferrite to ferromagnetic resonance at microwave frequencies (approximately 1.5 kg in the case of the previously mentioned 8.2 to 12.4 GHz and 12.4 to 18 GHz isolators). This became a serious problem at higher frequencies. Because the dc field required to bias the ferrite to resonance is proportional to frequency, at millimeter wavelengths this field becomes quite large, on the order of 1.5 to 3.5 T or more. In order to minimize the size and weight of millimeter wavelength resonance isolators, devices have been developed making use of magnetoplumbites, often called hexagonal ferrites (6). Such materials have a strong anisotropy field. All ferrite materials exhibit a certain amount of magnetic anisotropy because, in the individual crystallites that make up the material, the crystalline structure produces a preferred direction for the orientation of the magnetic moment vector. In a typical polycrystalline ferrite, however, these microscopic crystallites are randomly oriented with respect to each other, so that in the bulk material the effect of the anisotropy of the individual crystallites averages out, resulting in an isotropic material.

The materials most useful for resonance isolators are the so-called uniaxial compounds that possess a large anisotropy field along the C axis of the hexagonal crystals. By special processing used to produce the ferrite material, for instance by pressing the slurry of the appropriate material in the presence of a large magnetic field before firing, it is possible to produce a material in which the individual crystallites are oriented in a particular direction. This results in a large an-

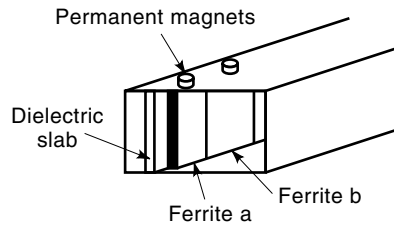

Figure 11. A resonance isolator using hexagonal ferrites.

isotropy field that in some ways is indistinguishable from an externally applied bias field. In this way, it is possible to make self-biased materials, or materials that require very little applied field to bias them to resonance at millimeter wavelengths.

Such an isolator is illustrated in Fig. 11. Thin slices of the hexagonal ferrite material are bonded to the dielectric slab, which serves to concentrate circularly polarized magnetic fields in the ferrite. In order to achieve wide bandwidth, the isolator may consist of a cascade of several sections of ferrite materials with different anisotropy fields and dielectric characteristics. Additional small permanent magnets can be used to achieve the correct resonant frequencies for the different sections. Figure 12 shows the performance of an isolator of this type weighing only 160 g. Materials have been developed enabling such isolators to be built at frequencies to 110 GHz.

FIELD DISPLACEMENT ISOLATORS

Field displacement isolators can be of many types but are all based on the fact that, in a transmission line loaded by a magnetically biased ferrite, the field pattern may exhibit nonreciprocal behavior by being distinctly different for the two directions of propagation. An isolator can then be built by judiciously locating dissipative material in an area where the fields are intense for one direction of propagation but weak for the other.

Figure 13 illustrates an early type of isolator based on this principal (7). As in the resonance isolator, a ferrite slab is introduced into the rectangular waveguide, and a dc magnetic field is applied across the narrow dimension of the waveguide; however, in this case the bias field is less than that required for ferromagnetic resonance. With an appropriate choice of

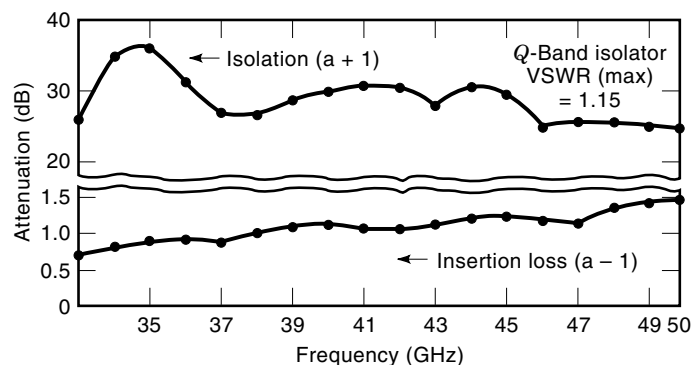

Figure 12. Performance of a 33 to 50 GHz isolator using hexagonal ferrites (6). Copyright © 1963 IEEE.

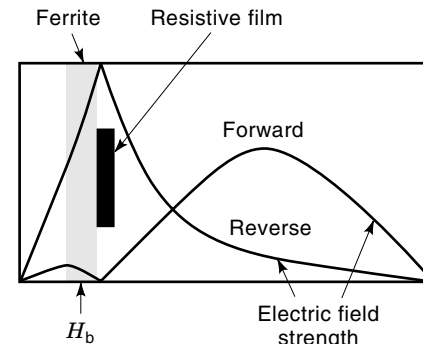

Figure 13. A field displacement isolator in a rectangular waveguide.

dimensions, ferrite properties, and magnetic bias, the resulting field pattern for the two directions of propagation can be as shown with a concentration of electric fields at one surface of the ferrite in one direction and minimal electric field at that surface for the other direction of propagation. If a sheet of resistive material is placed at this surface of the ferrite, it will dissipate energy for one direction and have very little effect on the other. An isolator of this type can produce, for example, isolation of greater than 30 dB over the 5.9 to 6.4 GHz band with a forward loss of less than 0.25 dB (8). The isolator of Fig. 13 was one of the earliest types of microwave ferrite devices, but it has largely been supplanted by the other types of isolators.

One more recent type of field displacement isolator that has significant unique advantages, particularly in regard to broadband operation, is the peripheral mode, or edge-guided, isolator. This device uses the edge-guided mode analyzed by Hines (9). Circulators and isolators using his mode of propagation were patented by Anderson (10).

The analysis by Hines revealed that in a stripline, or microstrip transmission line, with a wide center conductor and ferrite as the dielectric medium, and with a magnetic bias field perpendicular to the ground plane(s), a mode of propagation exists in which the energy concentrates towards one edge of the center conductor. The fields of this mode in stripline are illustrated in Fig. 14. The fields are similar to Transverse Electromagnetic (TEM) modes except for their displacement to one side or the other of the center conductor, depending on the direction of the bias field with respect to the direction

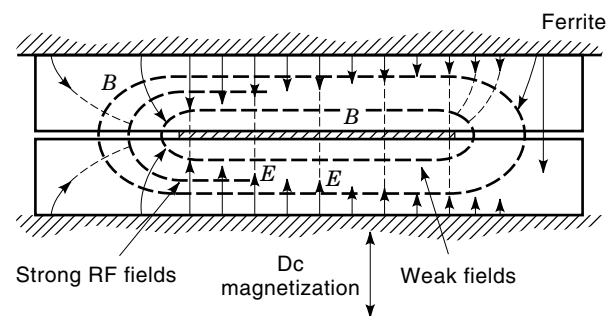

Figure 14. Fields in a ferrite-filled stripline as analyzed by Hines (9). Copyright © 1971 IEEE.

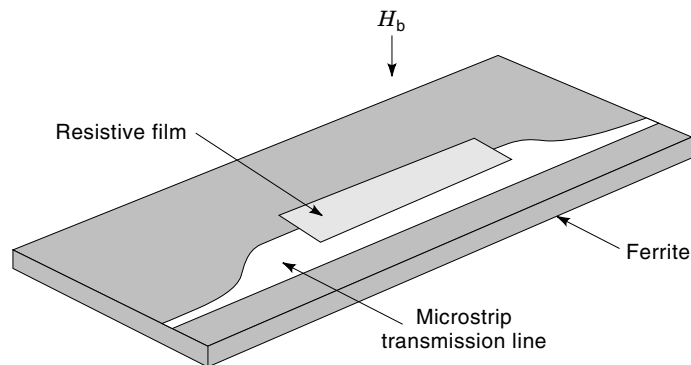

Figure 15. A broadband isolator using the edge-guided mode of a microstrip transmission line on a ferrite substrate.

of propagation. Hines has shown that for a very wide center conductor in comparison to the ground plane spacing, with a weak bias field, sufficient only to saturate the ferrite, this mode of propagation is free of dispersion and has a constant characteristic impedance over all frequencies.

Because the energy is concentrated at one edge of the center conductor, an isolator can be constructed by placing lossy material along one edge of this conductor. One direction of propagation will be unperturbed by this material while a signal in the opposite direction can be strongly absorbed. Such an isolator is illustrated in Fig. 15. In the idealized case, this isolator would have infinite bandwidth. In practice, the bandwidth is limited by low field losses at low frequencies, by higher-order modes at high frequencies, and by the difficulties in matching at the input and output to or from a conventional stripline or coaxial line. Nevertheless, very broad band isolators can be achieved using this approach. Hines reported the results shown in Fig. 16 for a basic microstrip configuration and in Fig. 17 for the case of added capacitive loading along the low-loss edge.

Thus the approach yields performance acceptable for some applications over a multioctave band.

The isolators described in this article are those that have found significant application in microwave systems. In recent years development of microwave isolators has continued with

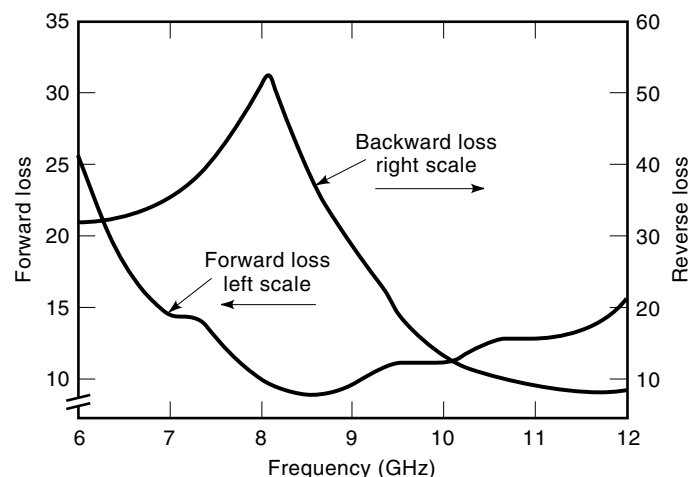

Figure 16. Measured performance of a microstrip isolator similar to that of Fig. 15 (9). Copyright © 1971 IEEE.

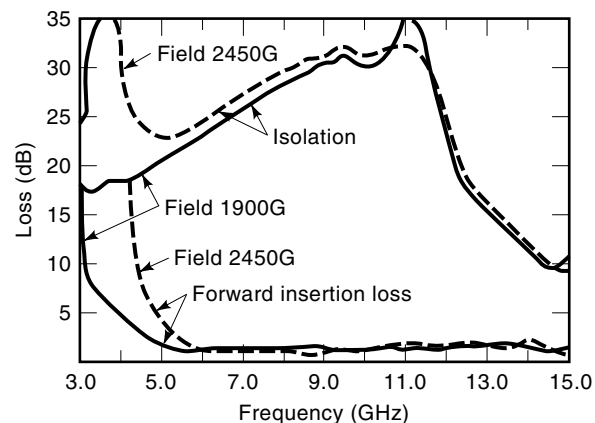

Figure 17. Measured performance of a microstrip isolator similar to that of Fig. 15, but with added capacitive compensation along the low-loss edge (9). Copyright © 1971 IEEE.

most effort being devoted toward development of isolators compatible with newer types of transmission lines, particularly for application at millimeter wavelengths. For example isolators have been developed for use with Finline (11,12), Image Line (13), and Quasi-optical transmission lines (14). These isolators will become important as these transmission media find application.

BIBLIOGRAPHY

1. C. L. Hogan, The microwave gyrator, *Bell System Tech. J.*, **31**: 1, 1952.
2. B. Lax and K. J. Button, *Microwave Ferrites and Ferrimagnetics*, New York: McGraw-Hill, 1962.
3. P. H. Vartanian, J. L. Melchor, and W. P. Ayres, Broadbanding ferrite microwave isolators, *IRE National Convention Record*, pt. 5, p. 79, 1956.
4. C. E. Barnes, Broad-band isolators and variable attenuators for millimeter wavelengths, *IRE Trans. Microwave Theory and Techniques*, **9**: 519, 1961.
5. M. T. Weiss, Improved rectangular waveguide resonance isolators, *IRE Trans. Microwave Theory and Techniques*, **4**: 240, 1956.
6. D. R. Taft, G. R. Harrison, and L. R. Hodges, Millimeter resonance isolators utilizing hexagonal ferrites, *IEEE Trans. Microw. Theory Tech.*, **11**, 346, 1963.
7. S. Weisbaum and H. Seidel, The field displacement isolator, *Bell System Tech. J.*, **35**: 877, 1956.
8. R. L. Comstock and C. E. Fay, Operation of the field displacement isolator in rectangular waveguide, *IRE Trans. Microwave Theory and Techniques*, **8**: 605, 1960.
9. M. E. Hines, Reciprocal and nonreciprocal modes of propagation in ferrite stripline and microstrip devices, *IEEE Trans. Microw. Theory Tech.*, **MTT-19**: 442-451, 1971.
10. R. Anderson, *Gyromagnetic device having a plurality of outwardly tapering members*. U.S. Patent 3,555,459, January 12, 1971.
11. L. E. Davis and D. B. Sillars, Millimetric nonreciprocal coupled-slot finline components, *IEEE Trans. Microwave Theory and Techniques*, **MTT-34** (7), 1986.
12. A. Beyer and K. Solbach, A new fin-line ferrite isolator for integrated millimeter-wave circuits, *IEEE Trans. Microwave Theory and Techniques*, **MTT-29** (12), 1981.

13. J. M. Owens et al., W-band ferrite-dielectric image-line field displacement isolators, *1989 IEEE MTT-S International Microwave Symposium Digest*, 1989.
14. G. M. Smith et al., Design, analysis and application of high performance permanently magnetised, quasi-optical, Faraday rotators, *1994 IEEE MTT-S International Microwave Symposium Digest*, 1994.

VERNON E. DUNN
Space Systems/Loral