

SOLAR ENERGY CONVERSION

The fossil fuels such as coal, oil, and natural gas, which maintain our industrialized world, will be surely running out sometime in the twenty-first century. Moreover, burning such fossil fuels causes the global air pollution problems due to the production of CO_2 , SO_2 , and NO_x , leading to global warming and acid rain problems. The development of alternative clean energy resources is, therefore, one of the most urgent subjects with which contemporary scientists have to struggle. Among them, utilization of solar energy seems to be the most promising and potential, and an important subject that a number of researchers in the world are now studying. A variety of ways for utilizing solar energy are known, for example, thermal energy by heat collectors, electrical energy by silicon solar cells, and chemical energy by photosynthesis, where the latter is referred to as the conversion of solar energy into chemical energy. The significant problems common to all these are the low cost performance, the low energy conversion efficiency, and/or the lack of persistence. In order to replace solar energy for fossil energy on an economical basis, it is absolutely necessary to overcome these problems as soon as possible.

Here, we focus on the solar energy conversion processes which involve chemical reactions in any way. The best known example of such a case is the plant photosynthesis; that is, plants can produce chemical energy in the form of a carbohydrate from CO_2 and H_2O with the help of light (1-5). Although the conversion efficiency is not high, the plant photosynthesis contains many important processes which we have to mimic in order to develop an artificial photosynthesis with a higher energy conversion efficiency. It is, therefore, indispensable to

know the mechanism of plant photosynthesis. Next, we give several examples of artificial photosynthesis using heterogeneous catalytic systems and wet-type solar cells using semiconductor photoelectrodes. This research field was boosted by Fujishima and Honda (6) who found that slightly reduced TiO_2 , a semiconducting oxide, can decompose water into hydrogen and oxygen under illumination of near ultraviolet light. Again, the problem was its low conversion efficiency. We overview the principle of the process and the recent progress in this field.

MOLECULAR PHOTOCHEMICAL ENERGY STORAGE AND PHOTOSYNTHESIS

Molecular Photochemical Energy Conversion

When molecules or complexes are photoexcited and transformed into products possessing higher energy than the initial state, a portion of the energy of photon is recognized to be converted into chemical energy (Fig. 1). Such photochemical reactions of molecules and complexes include (1):

1. photodissociation:



2. photoisomerization (cis-trans etc.):



3. photoaddition reaction:

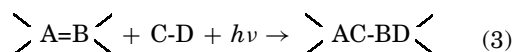

4. photoionization:



5. charge transfer:

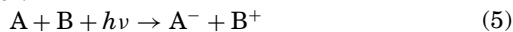

In order to utilize the chemical energy of the right side products as the energy source, the following three conditions should be satisfied.

1. The reverse reaction should be prevented. When a molecule AB in Eq. (1), for example, is photodissociated in the gas phase, the reverse reaction $\text{A} + \text{B} \rightarrow \text{AB}$ can easily occur in general, and the chemical energy stored in A and B is released as thermal energy. However, if the photochemical reaction products A and B can be separated and stabilized, the reverse reaction is

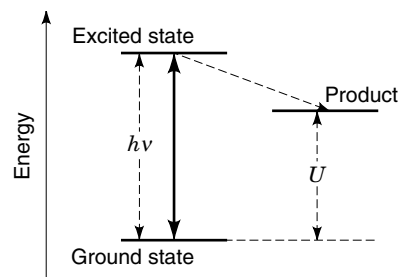
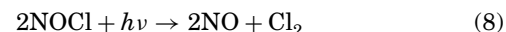
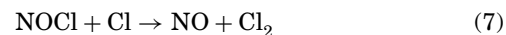
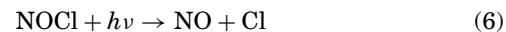

Figure 1. Energy diagram of molecular photochemical reaction. Molecule(s) and complex(es) are photoexcited from ground state to excited state with light energy $h\nu$ and transformed into product possessing free energy U .

avoided, and chemical energy storage is achieved. For instance, nitrosyl chloride (NOCl) is photodissociated into nitrogen monoxide (NO) and chlorine (Cl), and then the Cl atom reacts with another NOCl molecule to form a NO molecule and a Cl_2 molecule.



Since Cl_2 is soluble in liquid carbon tetrachloride (CCl_4) while NO is not, the photochemical products Cl_2 and NO can be separated; that is, chemical energy storage is achieved. It is also the case with photoionization and charge-transfer reactions. Photoionization reaction products M^+ and e^- in Eq. (4) are easily recombined in the gas phase. When photoionization is carried out in a condensed phase matrix, however, the electron can be stably trapped in the matrix. For example, when aromatic compounds or amines are photoionized in a hydrocarbon matrix frozen at liquid nitrogen temperature, a portion of the photogenerated electrons are known to be trapped stably in the frozen matrix.

2. Specific paths should be present that convert the chemical energy into nonthermal energies. When the photochemical reaction products are back to the initial state by reverse reaction, thermal energy is released; that is, the chemical energy stored in the photochemical reaction products is converted into thermal energy. If the thermal energy is the final, aimed energy to be obtained, one can directly utilize the solar energy as the heat source without employing such a lossy solar-to-chemical-to-thermal energy conversion route. Utilization of electrons obtained via photoionization (d) and charge-transfer (e) reactions for a specific redox reaction is an example of a fascinating molecular energy conversion process. In this case, however, the reverse reaction should be avoided, of course, and the photogenerated electrons should be transferred immediately to the redox system of interest. In order to realize this situation, again the photochemical reaction products [(M^+ and e^-) and (A^- and B^+)] should be separated, and in addition, there should be appropriate electron acceptors specially close to the reaction products. As easily imagined, in homogeneous systems in general, the electrons obtained by photochemical reactions are difficult to be utilized efficiently for specific redox reactions. Well designed, heterogeneous systems should be employed for such energy conversion processes.
3. If solar energy conversion is aimed, the visible light should be used for photochemical reactions. In most cases, however, photodissociation (a) and photoionization (d) proceed only with ultraviolet light. In such a case, only a minor portion of solar energy can be utilized for energy conversion, and the total energy conversion efficiency becomes quite low.

Photosynthesis in natural plants is an ideal solar energy conversion system that satisfies all the conditions mentioned above. Through learning and mimicking photosynthesis in plants, a growing number of researchers are now designing

and constructing artificial photosynthesis systems to develop efficient solar energy conversion systems.

Photosynthesis

Photosynthesis and Solar Energy Conversion. Green plants are converting CO_2 from the atmosphere and H_2O from soils into organic substances, utilizing solar energy. This is what we call photosynthesis of green plants (2). The energy stored in organic substances produced by plants is about 0.1% of the total annual solar energy reaching the Earth and is over 10 times the total amount of energy consumed by human activities per year. Organic substances produced by plants serve as food for human beings and animals, which is the energy source for activity and growth, organic raw materials for industrial production, and fuels. Fossil fuels can also be said to have resulted from the photosynthesis activity of ancient plants.

The net overall chemical reaction occurring in photosynthesis of plants is represented by

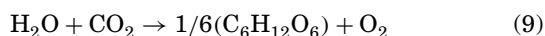

where $\text{C}_6\text{H}_{12}\text{O}_6$ is hexose. Thermodynamically, the right side reaction products have an energy 475 kJ per mole of CO_2 higher than the left side reactants, and this uphill reaction is assisted by solar energy. In other words, plants convert solar energy into chemical energy in the form of hexose and oxygen molecules. Since photoexcitation of eight moles of chlorophyll is utilized per mole of CO_2 , and the absorption band of chlorophylls lies around 700 nm (~ 170 kJ), the photoexcitation energy utilized for converting one mole of CO_2 is calculated to be $170 \times 8 = 1370$ kJ. If each reaction in the photosynthesis is assumed to occur with a quantum yield of 1, the energy yield is calculated to be $475/1370 = 0.35$, which is a much higher value than those obtained in photochemical reactions of simple molecules. Furthermore, the product, hexose, is a quite stable compound, which is another advantage of photosynthesis.

Mechanism of Photosynthesis

A Brief Review of Mechanism. The overall reaction in photosynthesis represented by Eq. (9) is a redox reaction and can be divided into two reactions:

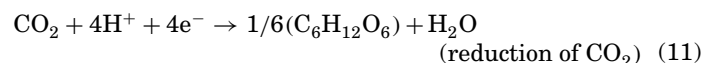

indicating that photosynthesis is an event occurring in plants where electrons are transferred from an H_2O molecule to a CO_2 molecule with the aid of solar energy. In other words, photosynthesis involves photoinduced electron transfer reactions.

H_2O and CO_2 molecules, which are absorbed through roots and stomata (pores) in leaf surfaces, respectively, reach pigment-bearing organells called chloroplasts, which are separated from other components of plant cells by a bimolecular

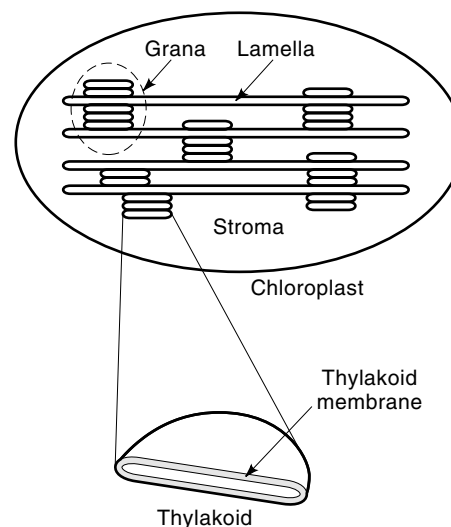

Figure 2. Schematic illustration of chloroplast and thylakoid. A biomolecular membrane separates the chloroplast from the other component of the plant cell. Lamella and grana are composed of sacklike disks called thylakoids. Absorption of photons, electron transfer, H_2O oxidation, and ATP synthesis occur on the thylakoid membrane, and CO_2 fixation takes place in stroma, the substrate part of the chloroplast.

membrane (Fig. 2). All the electron transfer processes in photosynthesis take place in chloroplasts. In chloroplasts, sacklike disks called thylakoid are present, forming lamella and grana as shown in Fig. 2. Absorption of photons, electron transfer reactions, H_2O oxidation, and ATP synthesis (to be discussed later) all take place on the thylakoid membrane. On the other hand, CO_2 fixation (reduction into hexose) occurs in the substrate part of chloroplasts called stroma.

Mechanism Details. The electron transfer processes involved in Eqs. (10) and (11) in chloroplasts are described below. Figure 3 shows a schematic illustration of thylakoid membrane along with electron and proton flows. Figure 4 shows electron flow and the chemical reaction scheme represented with a redox potential scale. As shown in Fig. 4, photosynthesis consists of two photoexcitation steps (uphill, light reaction) in pigment systems called PSI (photosystem I) and PSII (photosystem II), and a series of electron transfer steps (downhill, dark reaction) in the other parts.

PSI and PSII in green plants' chloroplasts contain a variety of pigments. In particular, chlorophyll *a* plays an important role in photosynthesis. Chlorophyll *a* is a Mg-porphyrin compound shown in Fig. 5, and is distributed in a wide variety of states in thylakoid membranes, which gives rise to a broad optical absorption band of chloroplasts. P700 and P680 are chlorophyll *a* molecules of specific states called reaction center chlorophylls in PSI and PSII, respectively. The fraction of the reaction center chlorophyll molecules are about 0.3–0.5% of the whole chlorophyll molecules. Chlorophyll *b* and other auxiliary pigments are also contained in these photosystems.

In PSII, the energy of light absorbed by pigments is transferred from pigments to pigments and is finally transferred to P680, which is thus photoexcited. The photoexcited electron in P680 is transferred successively to pheophytin (a porphyrin compound, Pheo), plastoquinone (a quinone compound,

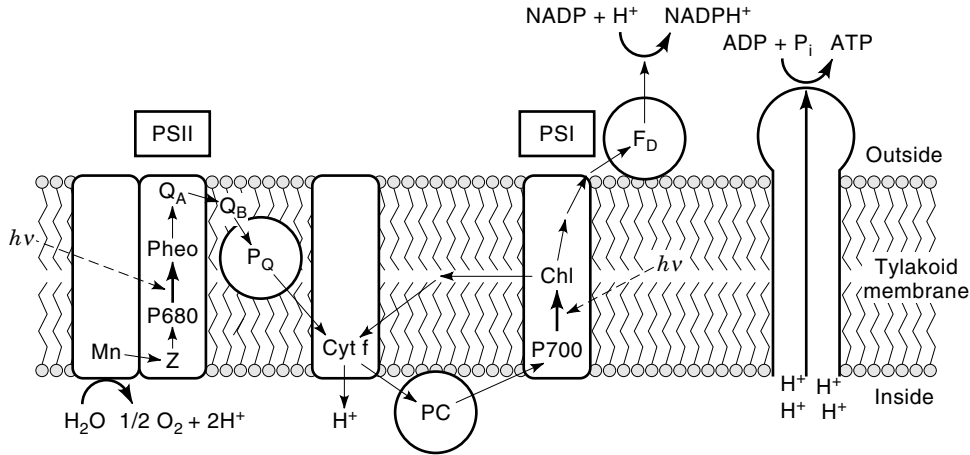

Figure 3. Schematic illustration of thylakoid membrane and electron flow and chemical reactions. PSII and PSI contain P700 and P680, chlorophyll molecules of specific states in thylakoid membranes. In PSII, the energy of light absorbed by pigments is transferred to P680. Then the photoexcited electron in P680 is transferred to Pheo, Q_A, Q_B, P_Q, Cyt f, PC, and finally to P700 in PSI. P680 is recovered from photooxidized P680⁺ by accepting an electron from an H₂O molecule, which is catalyzed by proteins containing Mn ions, and the electron is transferred via Z to P680⁺. In PSI, the energy of light absorbed by pigments is transferred between pigments and excites P700. The photoexcited electron is transferred to Chl. The electron is then transferred to F_D via several acceptors, and then to NADP to reduce NADP to NADPH, which is catalyzed by FNR. Then NADPH⁺ reduces CO₂ into C₆H₁₂O₆, which consumes energy released in the reaction, ATP → ADP + P_i.

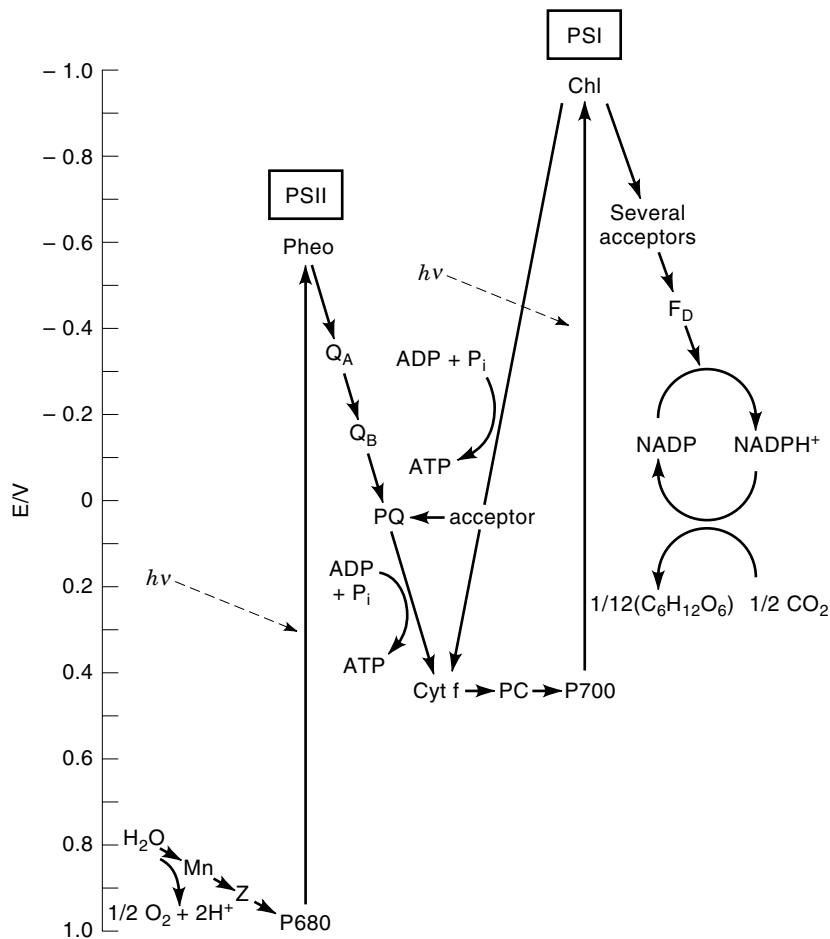

Figure 4. Schematic illustration of electron flow and chemical reactions in redox potential scale. See Fig. 3 legend.

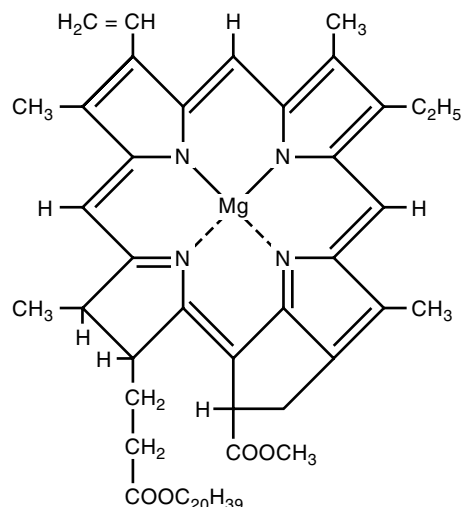
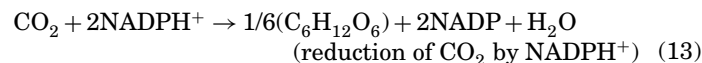
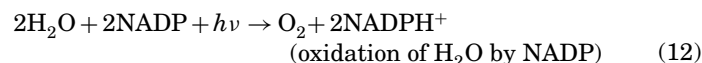

Figure 5. Molecular structure of chlorophyll *a*.

Q_A , Q_B , PQ), cytochrome *f* (a heme protein, Cyt *f*), plastocyanin (a copper-protein, PC), and finally, to P700 in PSI. On the other hand, P680 is recovered from photooxidized $P680^+$ by accepting an electron released from an H_2O molecule. The oxidation reaction of H_2O is now thought to be catalyzed by proteins containing Mn ions, and the electron is transferred via a plastoquinol (*Z*) molecule to $P680^+$.

In PSI, the energy of light absorbed by pigments is transferred between pigments and excites P700, the reaction center chlorophyll. The photoexcited electron is transferred to another chlorophyll molecule (Chl). The electron is then transferred to ferredoxin (iron-copper-protein, F_D) via several acceptors, and then to nicotinamideadenine dinucleotide phosphate (NADP) to reduce NADP to NADPH (a reduced form of NADP), where ferredoxin-NADP reductase (FNR) catalyzes the NADP reduction. Then, $NADPH^+$ reduces CO_2 into $C_6H_{12}O_6$, turning back to NADP.

Thus, photosynthesis reaction is regarded to consist of oxidation of H_2O by NADP and reduction of CO_2 by $NADPH^+$; namely, Eqs. (10) and (11) can be rewritten as



The reaction represented by Eq. (13), however, does not proceed spontaneously because the right side products of this reaction are higher in free energy than the left side reactants. In green plants, energy released by the following reaction is utilized to accomplish the reaction of Eq. (13)

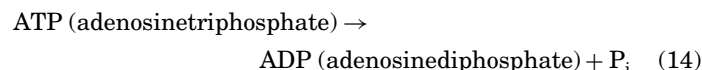

In other words, reduction of CO_2 proceeds by

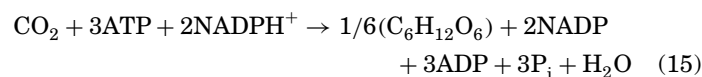

The reaction expressed by Eq. (15) proceeds via the so-called C3 cycle (Calvin-Benson cycle) including several intermediates.

As illustrated in Fig. 4, ATP is also synthesized in chloroplasts by phosphorylation of ADP, namely, the reverse process of Eq. (14). Since this ATP synthesis is achieved by utilizing energies released in downhill transfer of electrons that have photoexcited in PSI and PSII, this process is called photophosphorylation. Solar energy is converted to chemical energy here again and stored in ATP.

Artificial Photosynthesis. A reaction scheme of photosynthesis can be represented by the following equation:

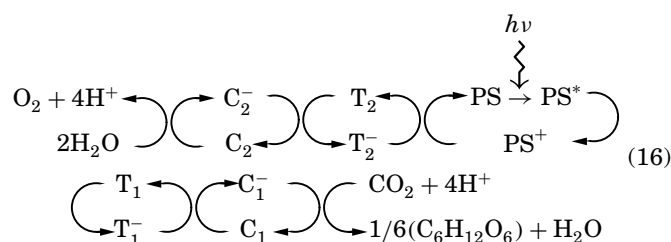

where PS is the photoexcitation center (or sensitizer), T_1 and T_2 are the electron transfer media (or relays), and C_1 and C_2 are the catalysts for CO_2 reduction and H_2O oxidation, respectively. In order to mimic the natural photosynthesis, appropriate sensitizers, relays, and catalysts, of course, should be employed. Efficient photoinduced charge separation and vectorial electron transfer, however, are the essential parts of the natural photosynthesis. The simplest way to realize them is to use the surface potential of a semiconductor at the semiconductor/liquid interface as the device for separating the charges, where semiconductors like TiO_2 , $SrTiO_3$, Fe_2O_3 , and CdS work as the electron transfer media (and as the sensitizer), organic dyes or organometallic complexes as the sensitizer, and Pt, Pd, and Rh metals as the catalyst.

Compartmentalization, that is, the arrangement of the photosynthetic apparatus in the thylakoid membrane is regarded, however, as an essential feature of the natural photosynthesis in approaches mimicking more closely to the natural process (3). So far, micelles, LB films, and vesicles have been used as biomimetic membranes. Aqueous micelles are spherical aggregates (4 nm to 8 nm in diameter) of surfactants, which possess hydrophilic head groups and hydrophobic alkyl chains containing 6 to 20 carbon atoms. LB films are formed by spreading surfactants over water, where the polar headgroups of the amphiphiles are in contact with water, while their hydrocarbon tails protrude above it. Vesicles are spherical or ellipsoidal aggregates possessing aqueous inner spaces and composed of bilayer phospholipids or surfactants, typically having diameters on the order of 50 nm and a thickness of 5 nm. Vesicles composed of phospholipids and synthetic surfactants are referred to as liposomes and surfactant vesicles, respectively.

For example, micelle-mediated charge separation and electron transfer have been demonstrated in phenothiazine (PTH) solubilized in sodium dodecyl sulfate (SDS) micelles. A larger photoionization quantum yield of PTH was obtained in the SDS micelles than in homogeneous methanolic solutions, and electron transfer from PTH in the micelles to Cu^{2+} and Eu^{3+} adsorbed on the micellar surface occurred at higher rates

than in homogeneous solutions. Vesicle-mediated electron transfer has also been recognized from ethylenediaminetetraacetate, EDTA, to methylviologen, MV^{2+} , via tris(2,2-bipyridine)ruthenium(II), $Ru(bpy)_3^{2+}$, a sensitizer, where EDTA was distributed in the bulk aqueous solution, and MV^{2+} and $Ru(bpy)_3^{2+}$ were placed on the inner and outer surfaces of dihexadecyl (DHP) vesicles, respectively.

Intramolecular photoinduced charge separation and electron transfer is another challenge. Electron transfer has been recognized in a synthesized triad consisting of a tetraarylporphyrin (P) covalently linked to both a quinone (Q) and a carotenoid polyene (C). Excitation of C-P-Q by a picosecond laser pulse resulted in a rapid formation of charge-separated species, $C^+ \cdot -P-Q^- \cdot$, with a quantum yield of 0.25 and a lifetime of several microseconds. Very recently, photoinduced electron transfer with a quantum yield of 0.83 and a lifetime of 55 ms has been achieved in a molecular pentad consisting of a porphyrin dyad covalently linked to a carotenoid polyene and a diquinone moiety (4).

There is another challenge combining the membrane and intramolecular approaches (5). A molecular triad consisting of carotenoid polyene (C), an electron donor, and a naphthoquinone moiety fused to a norbornene system bearing carboxylic acid group (Q), an acceptor, linked to a photosensitive tetraarylporphyrin (P). This triad was incorporated into the bilayer of a spherical liposome. When the triad incorporating the liposome was photoexcited, reduction and oxidation potentials were established near the outer and inner surfaces of the bilayer, respectively. In response to this redox potential across the bilayer, a freely diffusing quinone molecule alternates between its oxidized and reduced forms to convey protons across the bilayer with an overall quantum yield of 0.004, creating a pH gradient between the inside and outside of the liposome.

HETEROGENEOUS PHOTOCATALYSIS

Heterogeneous photocatalysis is a photochemical process in which the catalyst is present in a separate phase. In a general case, the catalyst is a solid, the reactants and products are in gaseous or liquid phases, and the catalytic reaction occurs on the surface of the solid.

Heterogeneous Photocatalysis Process

In analogy with chlorophyll which acts as photocatalysts for the photosynthesis of plants, dyes or semiconductors, which are stable and relatively easy to handle, are used as photocatalysts in the artificial photosynthesis. The photocatalytic mechanism in the photosynthesis involving water oxidation and CO_2 reduction is explained on the basis of electron transfer mainly consisting of the following steps: (1) water oxidation catalytic reaction (water as electron source), (2) electron transfer in photoexcited state (separation of photoexcited electron and hole), and (3) CO_2 reduction catalytic reaction (synthesis of carboxyl materials). Figure 6 shows the simplified mechanism of the photocatalysis by a semiconductor photocatalyst whose surface is loaded with a metal or metal oxide.

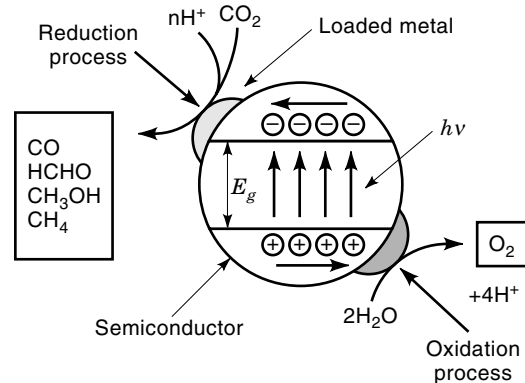

Figure 6. Schematic diagram of a photocatalysis process for reduction of CO_2 to methane and others by a semiconductor photocatalyst loaded with a metal or metal oxide.

from reductants to oxidants. In the overall process, the semiconductor photocatalyst remains unchanged since both the electrons and the holes are simultaneously consumed.

Photocatalysis by Semiconductor Particles

Small size semiconductor particles are effective for photocatalytic reaction from the following view points: (1) increase in the number of adsorption sites based on the increase in the surface area, (2) increase in the reduction and oxidation abilities by the shifts of the energy levels due to the quantum size effect, and (3) decrease in the duration for photoinduced charges to reach the surface, which correlates reciprocally with the surface density of the charge calculated with the finite depth well model. Small particles, however, decrease in the space required for the photoinduced electron-hole pairs to be separated, resulting in their easy recombination.

Semiconductors loaded with metals effectively separate electron-hole pairs. Metal particles on the semiconductor collect electrons which are excited by irradiation and pass them to reactant. The loaded small metal particles which are dispersed on the surface of the semiconductor thus improve the catalytic activity of the semiconductor in the consequent chemical reactions. The activity and reaction selectivity are found to strongly depend on the metal and method of preparation (metal loading). For example, the Pt/TiO_2 photocatalyst is highly active for dehydrogenation of organic compounds compared with plain TiO_2 .

Photosplitting of Water

Figure 7 shows the positions of a redox potential of H_2O and flatband potentials of various semiconductor catalysts. For complete splitting of water, the conduction band edge must be more negative of the reduction potential of H^+ for the generation of H_2 , and the valence band edge more positive of the oxidation potential of H_2O to generate O_2 . Semiconductors with a larger bandgap, however, have serious problems that they cannot efficiently utilize solar energy, and photocorrosion is liable to occur in aqueous solution as found for CdS.

Stoichiometric water photosplitting was first confirmed using Pt/TiO_2 covered with a very thin layer of water. The loaded metal is, however, also so active for the back reaction of hydrogen with oxygen that sustained evolution of hydrogen

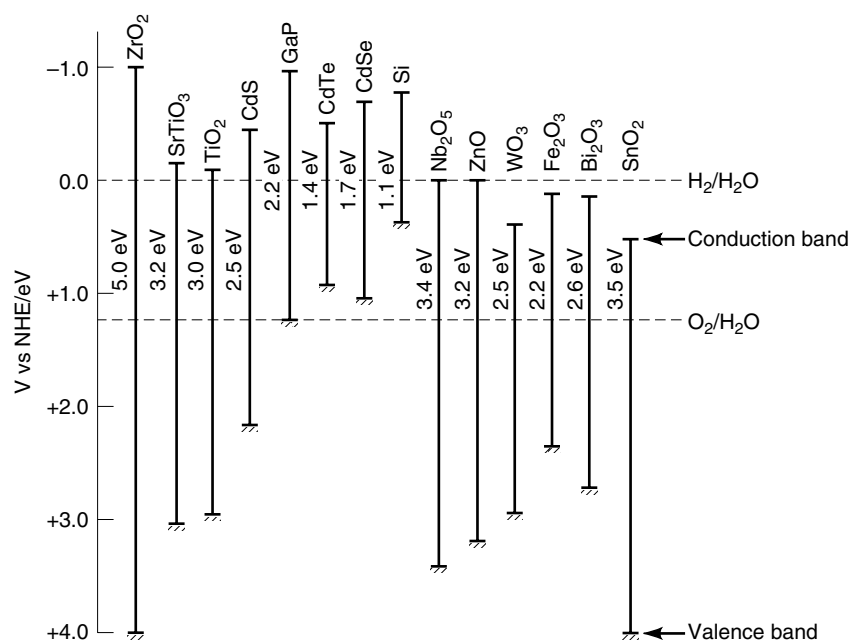

Figure 7. Relationship between the redox potential of H_2O and flatband potentials; bandgaps of various semiconductor photocatalysts.

and oxygen hardly occurs in aqueous suspensions of metallized semiconductors. Covering the surface of Pt/TiO_2 with a layer of NaOH increases the quantum efficiency up to 17% (7).

Some layered niobates such as Ni-loaded $\text{K}_4\text{Nb}_6\text{O}_{17}$ decompose water into H_2 and O_2 in the stoichiometric ratio since the products of H_2 and O_2 are separated between different layers to restrain their recombination. Ion-exchangeable layered Perovskite type niobates show interesting photocatalytic activity with visible response (8). Niobates and titanates with characteristic tunnel structures have been shown to be potential candidates as efficient photocatalysts for the splitting of water. $\text{Pb}_{1-x}\text{K}_x\text{Nb}_2\text{O}_6$, $\text{M}_2\text{Ti}_n\text{O}_{2n+1}$ (M = alkaline metal atom or proton, $n = 3, 4, 6, 8$) and BaTi_4O_9 are the examples (9).

An Na_2CO_3 addition to $\text{Pt}-\text{TiO}_2$ suspension in water promotes the stoichiometric decomposition of water with the highest H_2 evolution rate of $568 \mu\text{mol/h}$ known so far (10). The Na_2CO_3 addition has proved to be very useful to accelerate water splitting for various oxide semiconductor catalysts. The formed carbonate radicals in the system produce peroxy-carbonates by self-coupling or reacting with $\text{OH}\cdot$ radicals, resulting in the irreversible evolution of O_2 gas and the easy detachment from the surface of the catalysts. Decomposition of water by an AM1 solar UV light irradiation has been tried for the first time and found to take place efficiently as well as stoichiometrically in the presence of $\text{NiO}_x-\text{TiO}_2$ catalyst (11). The present problems in photocatalysts for the complete water splitting are the low efficiency and its difficulty in utilizing the visible light.

Other Applications

Photocatalysts, especially TiO_2 due to its oxidizing power and photochemical stability, have been utilized for various purposes such as air purification, CO_2 reduction, and NO_x fixation which all concern the environmental problem. The increase of CO_2 in the atmosphere and the accompanied global warming problem have been highlighted in the last decade. The

possibility of photocatalytic fixation of CO_2 has been shown by using metal complexes such as $[\text{Ru}(\text{bpy})_3]^{2+}$, semiconductors, some of which are listed in Fig. 7, and dye-doped semiconductors or metal hybrids which can adsorb visible parts of solar light. In addition, uses of photocatalysts as deodorant, bacteria killer, and their applications in organic synthesis and even in cancer treatment are currently very attracting.

WET-TYPE SOLAR CELLS

Wet-type solar cells convert solar energy into chemical and/or electrical energy by utilizing light to drive or promote the photoelectrochemical (PEC) redox reactions in the electrolyte and at the metal or semiconductor electrodes. The cell at-

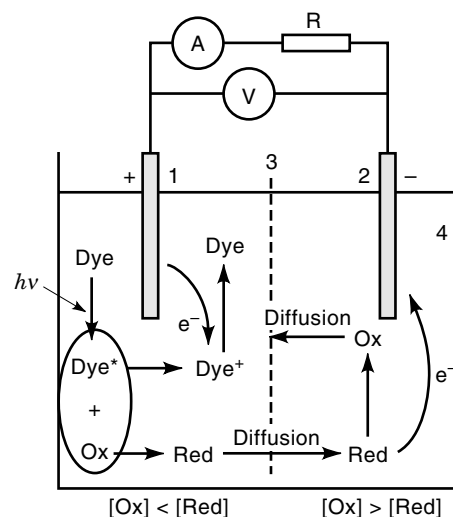

Figure 8. Photogalvanic cell. (1) and (2): metal electrodes, (3): porous diaphragm, and (4): electrolyte.

tracts much attention because of its low cost and promising utilization.

Photogalvanic Cells

The cell (Fig. 8) consists of two metal electrodes separated by a membrane, an electrolyte containing a dye as sensitizer, and a redox system either as an electron acceptor or as an electron donor. In such a cell, light is absorbed by the dye. The excited dye sensitizes the redox reaction, and homogeneous photochemical reaction occurs at the electrodes, forming products. The formed products then give or accept electrons to or from electrodes, generating photovoltage. Using this cell, one can only convert solar energy into electrical energy.

Taking an electrolyte containing a redox couple $\text{Fe}^{3+}/\text{Fe}^{2+}$ and dye $\text{Ru}(\text{bpy})_3^{2+}$ as an example, the following equilibrium is established in the dark:

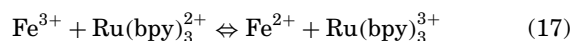

When the system is illuminated by light, the dye is excited, and an electron transfer occurs from the excited dye to Fe^{3+} :

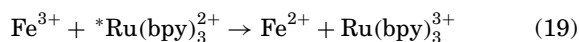
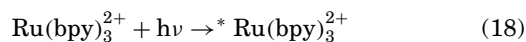

The equilibrium in the dark is then broken. The resultant increase of the concentration of Fe^{2+} and $\text{Ru}(\text{bpy})_3^{3+}$ changes the redox potential: that of $\text{Fe}^{2+}/\text{Fe}^{3+}$ is shifted negatively, while that of $\text{Ru}(\text{bpy})_3^{3+}/\text{Ru}(\text{bpy})_3^{2+}$ is shifted positively. As a result, Fe^{2+} gives an electron to one of the metal electrodes, and $\text{Ru}(\text{bpy})_3^{3+}$ accepts an electron from the rest metal electrode, giving rise to a photovoltage between the two metal electrodes. Besides $\text{Ru}(\text{bpy})_3^{2+}$, thionine, methylene blue, and acridine orange are often used as sensitizers.

It should be, however, pointed out that a photovoltage can be expected only when the incident light is absorbed near the one electrode because generation of a photovoltage depends on a competition for redox reaction and electron exchange between the electrode and the redox species. It is necessary to make a difference in the concentration of an electrode-active component between two identical electrodes so that the electron can exchange between the electrode and the redox species. For this reason, the conversion efficiency of this type cell cannot be in substance very high. Its maximum power is calculated to be 0.7 W m^{-2} when the incident light has an average terrestrial solar radiation of 30 W m^{-2} , and quantum efficiency of unity is assumed for the photochemical process (11).

Semiconductor Photoelectrochemical (PEC) Cells

The cell (Fig. 9) consists of a semiconductor electrode as a working electrode and a metal electrode as a counter electrode which both are immersed in an electrolyte containing redox couples (6). In such a cell, light is absorbed by a semiconductor electrode or by a dye molecule adsorbed on the semiconductor electrode. Using this type of cell, the solar energy can be converted into either electrical energy (regenerative or photovoltaic cells) or both chemical and electrical energy (photoelectrosynthetic or photocatalytic cells).

One can assume the semiconductor/electrolyte interface to be similar to the semiconductor/metal contact. Therefore, we

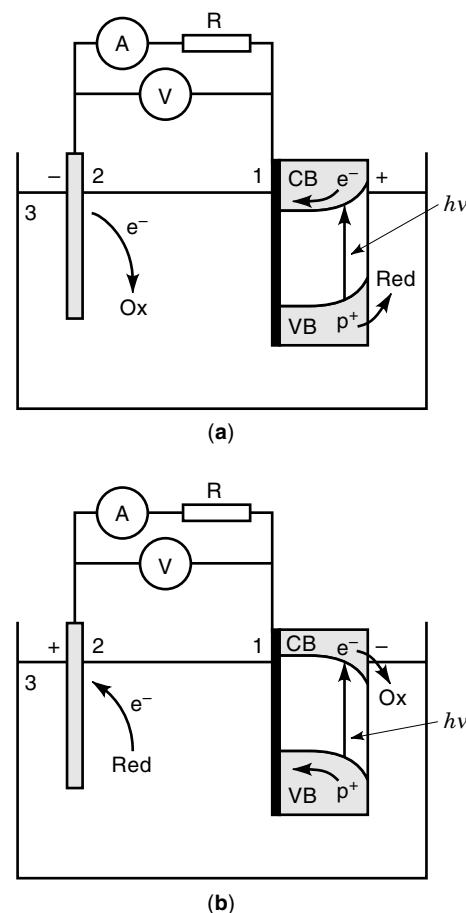

Figure 9. (a) *n*-type and (b) *p*-type semiconductor photoelectrochemical cell. (1): semiconductor electrodes, (2): metal counter electrodes, and (3): electrolyte. See Fig. 10 legend.

obtain a band model of semiconductor PEC cells in the dark as shown in Fig. 10(a) for *n*-type and Fig. 10(c) for *p*-type. An electrical field arises in the semiconductor across the space charge layer because of the low carrier density. An electron is excited from the valence band to the conduction band of a semiconductor by a light whose energy is larger than the bandgap of the semiconductor, leaving a hole in the valence band. The electrical field in the semiconductor separates the electron-hole pair as shown in Fig. 10(b) and (d), producing chemicals and/or generating electrical power accompanied by the change or lack of change of the electrolyte composition, respectively.

Regenerative or Photovoltaic Cells. In this cell, light which irradiates the semiconductor/electrolyte interface is converted into electricity with no change in the composition of the electrolyte or the semiconductor. The band model of this cell is also presented by Fig. 10. In the dark, at equilibrium [Fig. 10(a) and (c)], the Fermi level is equal throughout the system, including the back side ohmic metal contact of the semiconductor and the metal counter electrode. When such a system is illuminated, electron-hole pairs are generated and separated by the electric field, leading to a decrease of the band bending and producing a photopotential, U_{ph} , as indicated in Fig. 10(b) and (d). Connecting the ohmic contact to the

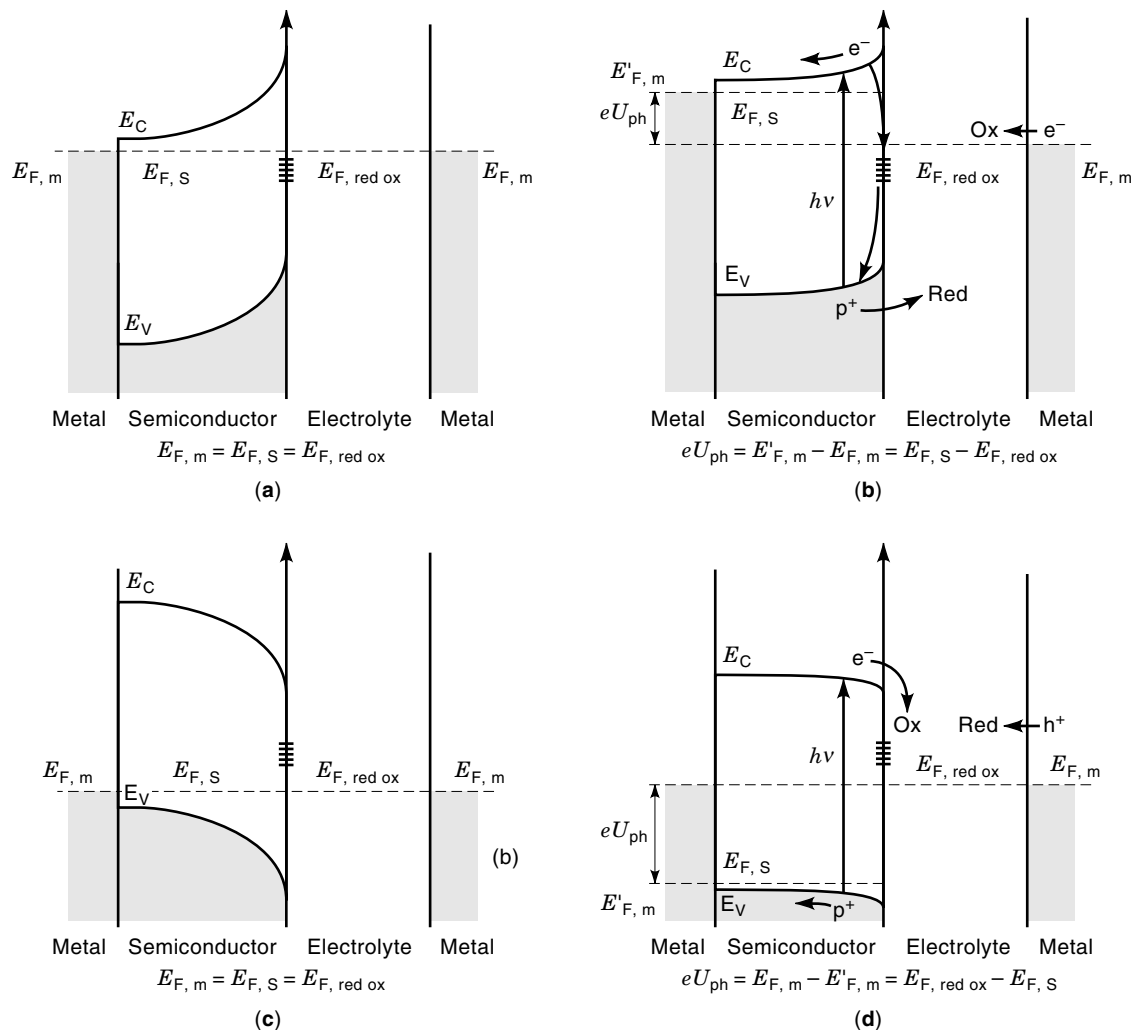

Figure 10. Energy scheme of a semiconductor photoelectrochemical cell. (a) *n*-type, in the dark, (b) *n*-type, under illumination, (c) *p*-type, in the dark, and (d) *p*-type, under illumination. When the cell is illuminated by light with energy greater than the bandgap of the semiconductor, the semiconductor electrodes absorb the photons. Electrons are excited from the valence band to the conduction band. The electric field in the space charge layer separates the electrons and holes thus generated, forming a photovoltage, U_{ph} .

counter electrode by a wire or a small load resistance, photocurrent flows through the external circuit, and redox reactions occur at the electrodes while the electric field remains unchanged upon illumination. In the case of *n*-type electrodes as shown in Fig. 10(b), the electrons excited by light reach the counter electrode, through the external circuit, and are transferred to the oxidized species there:



On the other hand, the holes created by light are transferred across the semiconductor/electrolyte interface to the reduced species:



A similar situation occurs for *p*-type electrodes as shown in Fig. 10(d).

The photocurrent i_{ph} depends linearly on the light intensity, I :

$$i_{ph} \propto I \quad (22)$$

and the photopotential U_{ph} is given by

$$U_{ph} = (kT/e) \ln(1 + \Delta p/p_0) \approx (kT/e) \ln I \quad (23)$$

for $\Delta p \ll n_0$, where p_0 is the minority carrier density in the bulk, Δp is the increment of p_0 on illumination, and n_0 is the majority carrier density. The highest possible photopotential depends on the band bending below the semiconductor surface at equilibrium in the dark. Theoretically, for a heavily doped semiconductor, $U_{ph,max} \approx E_g/e$. Unfortunately, experimental data (12) show that the photopotential is always considerably lower than the bandgap. One reason is that at equilibrium, the Fermi level of the redox system is far above the

valence band edge. Another possible reason is the recombination at the surface states as shown in Fig. 10(b) and (d).

Another topic of this cell is the stabilization of the semiconductor surface. The Anodic dissolution process competes with the redox reaction, very often making many semiconductor electrodes unstable. From the thermodynamic viewpoint, the semiconductor will be stable in water when the decomposition potential is much more positive of the O_2/H_2O redox potential. However, the thermodynamic data show that only wide bandgap semiconductors such as TiO_2 and $SrTiO_3$ meet the above condition. Therefore, redox couples should be selected for the PEC cell so that the redox potential is less than the decomposition potential of the semiconductor.

Photoelectrosynthetic Cells and Photocatalytic Cells. In photoelectrosynthetic cells, light is used to drive the overall cell reaction in a nonspontaneous direction ($\Delta G > 0$), so that radiant energy is stored as chemical energy (e.g., fuels). On the other hand, in photocatalytic cells, a reaction is driven in a spontaneous ($\Delta G < 0$) direction by the light energy. Here, radiant energy is not converted to chemical energy but is used to overcome the activation energy of the process. In both cases, the composition of the electrolyte changes.

Take photoelectrolysis of water as an example for the photoelectrosynthetic cells. The band model of the open circuit case for this cell can also be described, as in Fig. 10. It should be noted that in such a system, the position of the Fermi level of the electrolyte is not very well defined. It would be rather close to E_{O_2/H_2O}^0 and to the valence band at the surface if the electrolyte is saturated with oxygen. On the other hand, it may be close to E_{H_2/H_2O}^0 and to the conduction band if the hydrogen concentration is large. When the PEC cell is short-circuited, electrons in the conduction band are transferred to the counter electrode, and H_2 is generated there; whereas holes in the valence band are transferred to the surface of the semiconductor electrode to generate O_2 . When the Fermi levels of metal electrode are far below E_{H_2/H_2O}^0 , the generation of H_2 does not occur. Since no current flows, the band bending decreases, and a photopotential U_{ph} is developed. This photopotential increases with increasing light intensity until the Fermi level of the metal is moved above E_{H_2/H_2O}^0 . Then, the photocurrent starts to flow, and H_2 and O_2 are generated. It should be noted that the Fermi level can only be moved sufficiently upwards if the conduction band edge at the surface lies above E_{H_2/H_2O}^0 ; otherwise an externally applied voltage, U_{appl} , is necessary to shift the Fermi level. In this situation, one still has an energy gain as long as $U_{appl} \ll E_{O_2/H_2O}^0 - E_{H_2/H_2O}^0 = 1.23$ eV.

For this cell, the problem of semiconductor stability also exists.

Improvement of the Conversion Efficiency. In order to achieve a high conversion efficiency for the semiconductor PEC solar cells, the semiconductor electrode should meet the following four requirements: (1) an optimum bandgap of 1.5 to 2.0 eV, which responses to the solar spectrum, (2) a conduction band edge more negative of the reduction potential of redox species in an electrolyte combined with a valence band edge more positive of the oxidation potential, (3) rapid charge transfer kinetics to the electrolyte, and (4) strong resistance to corrosion of the semiconductor surface. No semiconductors investigated so far satisfy all of the requirements. As men-

tioned above, a problem is that photoelectrochemically stable semiconductors have wide bandgaps and hence, visible light cannot be utilized, whereas narrow bandgap semiconductors are often photoelectrochemically unstable. An enormous effort has, however, been made so far in order to enhance the conversion efficiency.

Adsorption of dye on the semiconductor electrode surface and doping of transition metal in the semiconductor electrode are the best known methods to extend the photoresponse of those photochemically stable, wide bandgap semiconductor electrodes to a visible region. A detailed description can be found in Ref. 13, and their simple mechanism is as follows.

Adsorption of Dye on the Semiconductor Electrode Surface. One can obtain a visible photoresponse for wide bandgap semiconductor electrodes by adsorbing a dye, such as ruthenium complexes, whose energy levels lie within the bandgap of semiconductor. Visible-light-induced current occurs when a visible-photon absorbed by a dye molecule gives rise to electron injection into the conduction band of the semiconductor. However, the conversion efficiency of the dye-sensitization PEC cell is as low as about 1%, mainly because of the poor light harvesting. Improvement of the light harvesting may be achieved by employing sol-gel-derived colloidal semiconductor electrodes, which will be described in the next paragraph.

Sol-Gel-Derived Semiconductor Film Electrodes (14,15). These electrodes are characterized by many surface states which mediate the electron transfer between the electrode and redox species. Our recent research showed that a large number of surface states shift the photoresponse to visible region. The same result was also obtained by Hagfeldt et al. (16). The sol-gel method provides an easy way to prepare film electrodes in a metastable phase such as anatase TiO_2 that cannot be obtained by the traditional method. The electron mobility is known to be larger in anatase than in rutile TiO_2 . The colloidal semiconductor film electrodes can be easily prepared by the sol-gel method (17). They have been found to exhibit a higher light harvesting ability even for diffuse daylight because of the large surface area. The reported highest overall light-to-electric energy conversion is 12% in such a condition. The PEC properties of the colloidal electrodes are sensitive to the size of the colloidal particles because of the barrier formed between the particles.

Doping of Transition Metal in the Semiconductor Electrode. To endow a wide bandgap semiconductor with a visible photoresponse, one can incorporate transition metals such as Cr, Co, Mn, Fe, and Ni into the semiconductor. The mechanism is to create energy levels within the bandgap to apparently "narrow" the bandgap. This will, however, increase the recombination of the photogenerated electron-hole pairs at the same time.

Doping of Noble Metal Nanoparticles in the Semiconductor Electrode (18,19). One can obtain visible photoresponse by incorporation of noble metal nanoparticles or co-incorporation of metal nanoparticles and dye molecules in the wide bandgap semiconductor electrodes (18,19). The mechanism is based on the enhancement of the dye sensitization or visible-light-excitation of electrons at the surface states within the bandgap of semiconductor by the surface plasma resonance of the metal nanoparticles. For example, visible photoresponse was found for Au or Ag nanoparticles doped TiO_2 electrodes, which was ascribed to the electron excitation from the surface states en-

hanced by the surface plasma resonance of the metal nanoparticles.

Doping of Semiconductor Particles in the Semiconductor Electrode. Visible photo response is induced by a narrow bandgap semiconductor doped in the wide bandgap semiconductor electrodes; for example, TiO_2 electrodes can be sensitized by doped CdS particles. Besides extending the photoresponse of the wide bandgap semiconductor electrodes, other attempts to improve the conversion efficiency have been made.

A protective coating film on the narrow bandgap semiconductor electrode is to cover an unstable narrow bandgap semiconductor electrode with a protective coating film, for example, the CdSe electrode covered with a TiO_2 coating film. The problem is that the Schottky barriers form at the interface between the protective coating and the narrow bandgap semiconductor, reducing the mobility of the photogenerated electrons and holes.

Mixed Semiconductor Electrode. It is possible to alter the bandgap of the semiconductors by mixing two semiconductors with different bandgaps. A solid solution of wide and narrow bandgap semiconductors, which is called a mixed semiconductor, may simultaneously have a resistance against the anodic decomposition and a visible photoresponse. For example, our recent research has found a conspicuous visible photoresponse for the sol-gel-derived $\text{Ti}_{1-x}\text{V}_x\text{O}_2$ solid solution film electrodes.

Semiconductor Electrode with Gradient Bandgap. Our research also has shown that it is possible to improve the conversion efficiency by preparing composite electrodes consisting of a wide bandgap semiconductor at the surface to absorb ultraviolet light and a narrow bandgap at the interior to absorb visible light. In order to eliminate the emergence of the Schottky barrier at the interfaces, the formation of a gradient bandgap semiconductor electrode is required (Fig. 11).

Fuel-Producing Photochemical Redox Reaction

Fuel-producing photochemical redox reactions use solar energy to generate a fuel, for example, hydrogen from water or

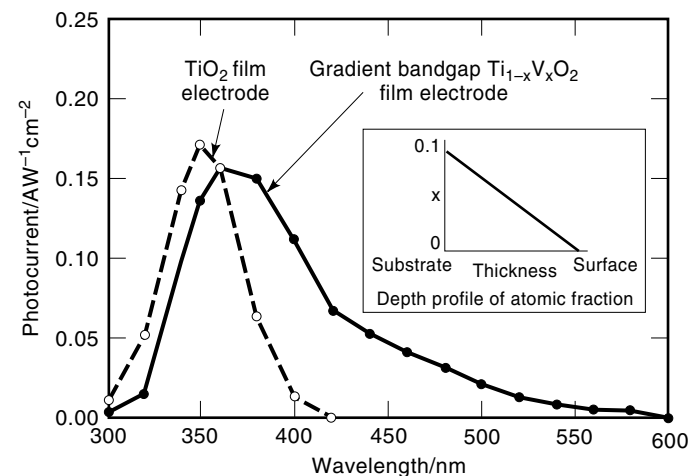

Figure 11. An action spectrum of a gradient bandgap $\text{Ti}_{1-x}\text{V}_x\text{O}_2$ film electrode that is compared with one of a pure TiO_2 film electrode. The thicknesses of $\text{Ti}_{1-x}\text{V}_x\text{O}_2$ and TiO_2 film electrodes are 145 nm and 110 nm, respectively. The composition of $\text{Ti}_{1-x}\text{V}_x\text{O}_2$ film changes gradually as shown in the inset. Compared with the TiO_2 film electrode, the photoresponse of gradient bandgap $\text{Ti}_{1-x}\text{V}_x\text{O}_2$ film electrode extends to a considerably long wavelength.

methane from carbon dioxide. Solar irradiation excites the light absorber immersed in water, such as $[\text{Ru}(\text{bpy})_3]^{2+}$ and TiO_2 ; then, electron transfer occurs between the light absorber and the redox species of water, producing H_2 as fuel and O_2 . Redox catalysts are required for attaining high conversion efficiency. Such a system can be regarded as a selfcell. For example, the system contains TiO_2 particles as light absorbers, and Pt and RuO_2 adsorbed on TiO_2 particles as redox catalysts, where Pt works as the cathode, and RuO_2 works as the anode.

BIBLIOGRAPHY

1. H. Tsubomura, Chemical conversion of light energy, *Kagaku Sosetsu*, **12**: 29–44, 1976 (in Japanese).
2. M. Pessaraki (ed.), *Handbook of photosynthesis*, New York: Marcel Dekker, 1997.
3. J. H. Fendler, Photochemical solar energy conversion. An assessment of scientific accomplishments, *J. Phys. Chem.*, **89**: 2730–40, 1985.
4. D. Gust et al., Photoinduced electron and energy transfer in molecular pentads, *J. Am. Chem. Soc.*, **115**: 11141–52, 1993.
5. G. Steinberg-Yfrach et al., Conversion of light energy to proton potential in liposomes by artificial photosynthetic reaction centres, *Nature*, **385**: 239–241, 1997.
6. A. Fujishima and K. Honda, Electrochemical photolysis of water at a semiconductor electrode, *Nature*, **238**: 37–38, 1972.
7. K. Yamaguti and S. Sato, Photolysis of water over metallized powdered titanium dioxide. *J. Chem. Soc., Faraday Trans. 1*, **81**: 1237–1246, 1985.
8. J. Yoshimura et al., Visible light induced photocatalytic behavior of a layered perovskite type niobate, $\text{RbPb}_2\text{Nb}_3\text{O}_{10}$, *J. Phys. Chem.*, **97**: 1970–1973, 1993.
9. Y. Inoue, Y. Asai, and K. Sato, Photocatalysts with tunnel structures for decomposition of water, *J. Chem. Soc., Faraday Trans.*, **90**: 797–802, 1994.
10. K. Sayama and H. Arakawa, Significant effect of carbonate addition on stoichiometric photodecomposition of liquid water into hydrogen and oxygen from platinum-titanium (IV) oxide suspension, *J. Chem. Soc.: Chem. Commun.*, 150–152, 1992.
11. H. Arakawa, Creation of new energy by photocatalyst: Technology of clean hydrogen fuel production from solar light and water, *Laser Res.*, **25** (6): 425–430, 1997 (in Japanese).
12. R. Memming, Solar energy conversion by photoelectrochemical process, *Electrochim. Acta*, **25**: 77–88, 1980.
13. H. O. Finklea, *Semiconductor Electrodes (Studies in Physical and Theoretical Chemical)*, New York: Elsevier, 1988.
14. T. Yoko, K. Kamiya, and S. Sakka, Photoelectrochemical properties of TiO_2 film prepared by the sol-gel method, *Yogyo-Kyokai-Shi (J. Ceram. Soc. Jpn.)*, **95**: 150–155, 1987.
15. T. Yoko et al., Sol-gel derived TiO_2 film semiconductor electrode for photocleavage of water: preparation and effects of post-heating treatment on the photoelectrochemical behavior, *J. Electrochem. Soc.*, **138**: 2279–2285, 1991.
16. A. Hagfeldt, U. Bjorksten, and S.-E. Lindquist, Photoelectrochemical studies of colloidal TiO_2 Film, *Solar Energy Mater. Solar Cells*, **27**: 293–304, 1992.
17. B. O'Regan and M. Gratzel, A low-cost, high-efficiency solar cell based on dye-sensitized colloidal TiO_2 films, *Nature*, **353**: 737–740, 1991.
18. G. Zhao, H. Kozuka, and T. Yoko, Effects of the incorporation of silver and gold nanoparticles on the photoanodic properties of

- rose bengal sensitized TiO₂ film electrodes prepared by sol-gel method, *Thin Solid Films*, **277**: 147–154, 1996.
19. G. Zhao, H. Kozuka, and T. Yoko, Effects of the incorporation of silver and gold nanoparticles of rose bengal sensitized TiO₂ film electrodes prepared by sol-gel method, *Solar Energy Mater. Solar Cells*, **46**: 219–231, 1997.

GAOLING ZHAO
Zhejiang University
HIROMITSU KOZUKA
HONG LIN
TOSHINOBU YOKO
Kyoto University