

HYDROELECTRIC GENERATORS

Hydraulic generating units for electric power generation normally run at a fixed speed to provide an electrical frequency of 50 or 60 Hz for conventional system needs. The turbines operate most efficiently at only one operating point, which is the best combination of head, speed, and discharge. Any deviation from these conditions can cause a marked reduction in hydraulic efficiency because of flow separation, secondary flows, turbulence, and friction, all of which in turn, can cause pressure and shaft torque fluctuations and cavitation.

High voltage direct current (HVDC) transmission of power for electric utilities was introduced some 40 years ago. Electrical system planners, however, over the last few years have reexamined its application to remote hydro sites to reduce costs associated with the expensive sending-end conversion equipment. Thus an electrical arrangement known as the “unit connection” has been developed. This innovation reduces capital and operating costs considerably and also allows conventional generating units to operate at an adjustable speed/frequency, generally in the range of $\pm 10\%$, with no increase in turbine cost and only a modest increase in generator and converter transformer costs.

When there is no necessity for fixed frequency at the generating station, hydraulic turbines can operate without the previous restriction of constant speed, thereby improving hydraulic characteristics throughout the normal range of operating conditions. Depending on river hydraulic regimes in relation to plant size, this opportunity could represent a large revenue improvement. Then adjustable speed, in this context, depends wholly on the conditions that the transmission system is HVDC and that there is no requirement for fixed frequency, such as an interconnection with another ac system.

When high voltage ac and dc systems are compared at the planning stage, recognition should be given to the additional economic benefit that could result from adjustable speed operation. Utilities in Canada and Brazil are exploring the possibility of profiting from the benefits of the HVDC unit connection with adjustable speed operation for future hydroelectric developments.

This article describes the basic concept of HVDC unit-connection schemes leading to the efficiency of adjustable speed turbine operation (sometimes called “variable speed” in referenced literature). Then it moves into a detailed analysis of the effects of HVDC and adjustable speed/frequency on the hydroelectric generator that is the basis of the article. Finally, the article continues with a brief discussion of other related considerations involved with this method of hydroelectric generation and transmission.

HVDC Unit-Connection Schemes

Conventional HVDC transmission schemes in remote hydroelectric sites are similar to Fig. 1, which shows the Limestone generating station on the Nelson River in Canada. The basic feature is that the generating units feed a common, high-voltage ac bus on the secondary side of the generator transformers. The presence of tuned ac filters on this bus imposes steady-state operation at a fixed electrical frequency. As a result, the loss of filter banks by protection action during faults or power swings becomes a highly probable contingency that subjects the station to harmonic distortion usually leading to large overvoltages which must be recognized

2 HYDROELECTRIC GENERATORS

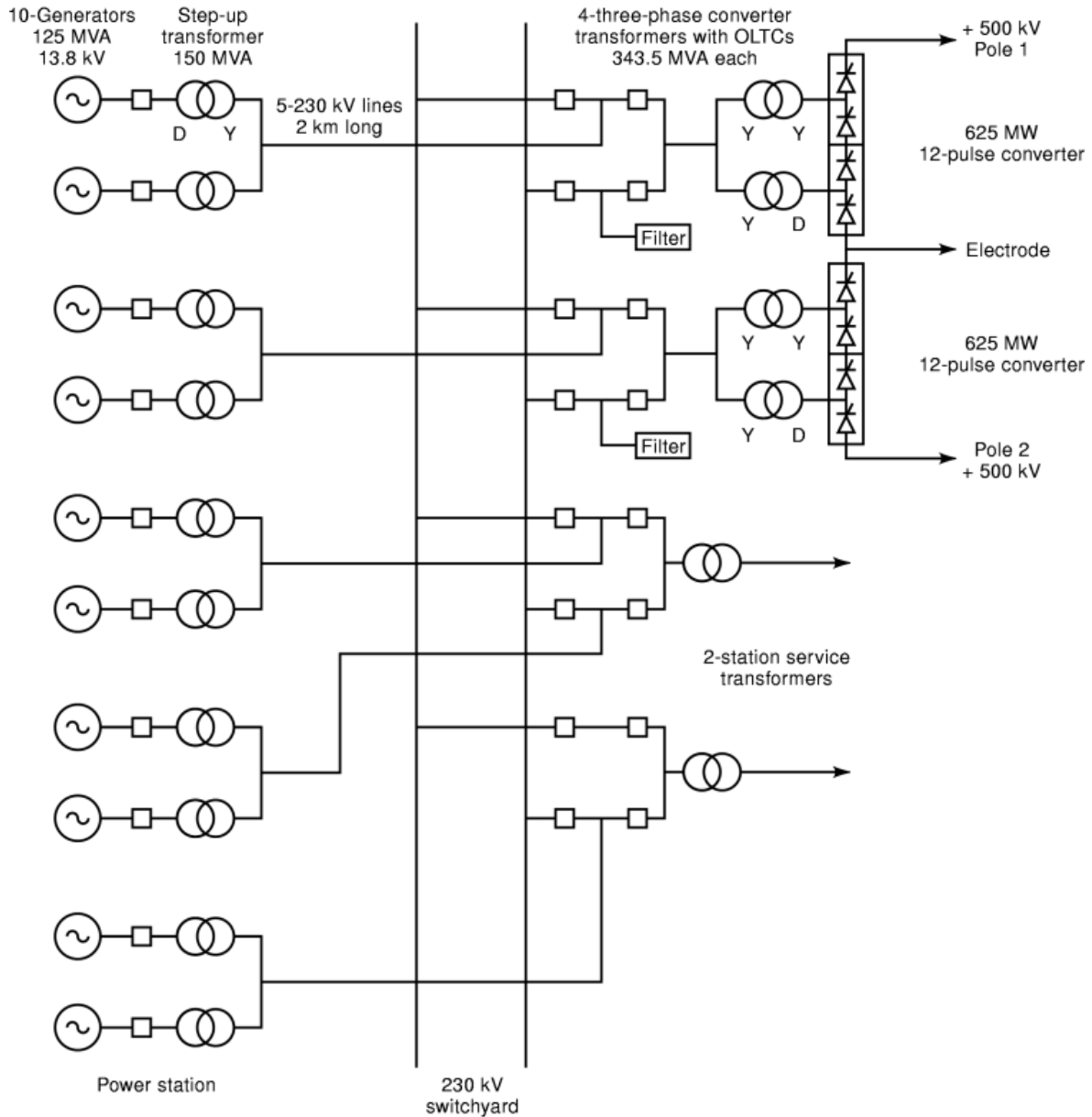

Fig. 1. Example of a conventional HVDC sending-end converter station arrangement, as used on the Nelson River, Canada.

in the overall station design. Furthermore, the large filter capacitances can cause generator self-excitation due to load rejection, resulting in substantial overvoltages. For the station to cope with these conditions, large overrating factors (1.4 and above) have to be used when coordinating converter valves, transformers, and generator stator insulation ratings (see Ref. 1, Chap. 5).

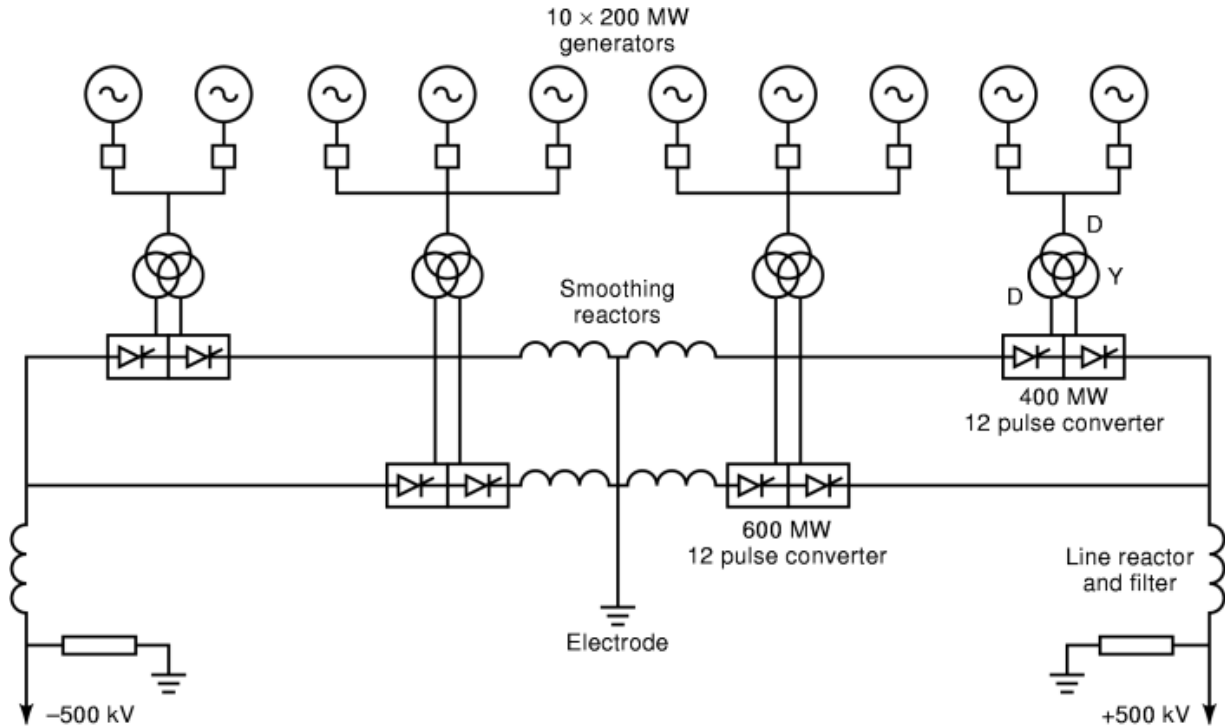

Fig. 2. Example of a unit-connected HVDC sending-end arrangement with generators connected in groups. Copyright International Water Power and Dam Construction. Used with permission.

There are several possible arrangements for unit connection. Figure 2 shows one example. A group of generators is paralleled directly on a generator bus and connected to a 12-pulse converter transformer arrangement, thereby eliminating one level of transformation and the ac switchyard and ac filters, all of which represents large capital cost reductions. Generator breakers, in this example, are necessary but they must be carefully selected because they must operate successfully throughout a given range of variable frequencies. Low frequency increases the duration of overcurrent in the wave, and high frequency introduces the possibility of a voltage restrike. In some cases, the opportunity to reduce costs may be available by combining the converter valves and transformers within the powerhouse (3).

In addition to the major equipment cost reductions mentioned, there are significant electrical equipment energy-loss savings, staff and maintenance cost reductions, and reliability improvement because of the overall simplicity of the scheme.

On the downside, the main disadvantage is that the generating station cannot easily be interconnected with an adjacent ac system. It may, however, be able to supply a small local load at some additional cost.

Capital savings in adopting a unit-connected design are site-dependent. They can be determined only by examining all of the alternatives for a specific project. Useful guidance of general validity may be obtained from the cost breakdown of a conventional HVDC converter sending-end station, as shown Refs. in 1 (Chap. 2) and 3.

4 HYDROELECTRIC GENERATORS

Hydraulic Turbines

Utility hydraulic turbines can be

- single-regulated (needle stroke on impulse turbines, wicket gates, or runner blades on reaction turbines) or
- double-regulated (wicket gates and runner blades on reaction turbines).

The ability to adjust turbine speed introduces an additional regulating variable with possible advantages to both single- and double-regulated turbines.

Unlike steam turbines where rated steam conditions are constantly maintained by the operating staff, hydraulic turbine water head and flow conditions, subject to the vagaries of nature, are rarely constant. Therefore adjustable speed is an intrinsic feature of hydraulic machines because speed is directly related to water head. In some existing installations, hydraulic turbines, such as pump-turbine machines, are designed to operate at two speeds, each applicable to a different mode of operation (i.e., pumping or generating), thereby providing a sufficiently high hydraulic machine efficiency in each mode.

Present hydraulic machines are designed as compromises between efficiency and operational flexibility. Once adjustable speed can fully compensate for head variations, the hydraulic design may be directed to obtaining load flexibility.

HVDC unit connection can simplify the operation of the generating station and also make it possible to operate at adjustable speed because the generating frequency, decoupled by the dc link, is free of the obligation of synchronous operation.

If the turbine output limits are already established by instabilities and the avoidance of cavitation (i.e., the erosion that takes place on the surface of runner blades from the implosion of air and vapor bubbles at high pressure), the only remaining concern with head variation is cavitation at the inlet edge of the runner blade. This type of cavitation is very strong and comes from incorrect flow angles caused by extremely high and low heads. Because speed is closely related to head by flow similarity laws, it can be shown that speed must vary with the inverse of the square root of the head variation to maintain flow angles (Ref. 1, Chap. 3). Consequently, if speed can be varied freely there is no minimum head for the turbine, and the maximum limit is imposed only by mechanical considerations. Although cavitation at partial load is not of much concern for hydro machines with Kaplan blades, rough operation can be experienced at extremely low heads, making adjustable speed also a possibility for these units.

Speed variation does not affect the mechanical design of the turbine or the generator because both must be designed for the maximum theoretical runaway speed (when the generator has lost its load and the governor has failed to close the gates in the maximum gate opening position at maximum head). However, the dynamic properties must be reviewed to avoid any critical frequency resonances. The first lateral critical frequencies of the shaft are normally well above the maximum runaway speed, so this is not a concern, but others may exist and should be checked. Furthermore, the typical arrangement for turbine generator units is such that most of the inertia is located in the generator rotor. Hence, the air gap torque harmonics are spent mostly in accelerating the generator rotor inertia itself, and only a minor fraction of the energy associated with them is transmitted through the shaft.

Hydraulic passage excitations are also a consideration. When turbine low-frequency pulsations due to vortices in the draft tube resonate with the power plant structure, severe operational limitations may be imposed leading to energy losses and occasionally to structural damage. Such excitations represent actual constraints in fixed-speed operation when some operating points have to be avoided. Adjustable speed has the potential to eliminate the constraints and most of the resulting energy losses by a relatively small change of operational speed.

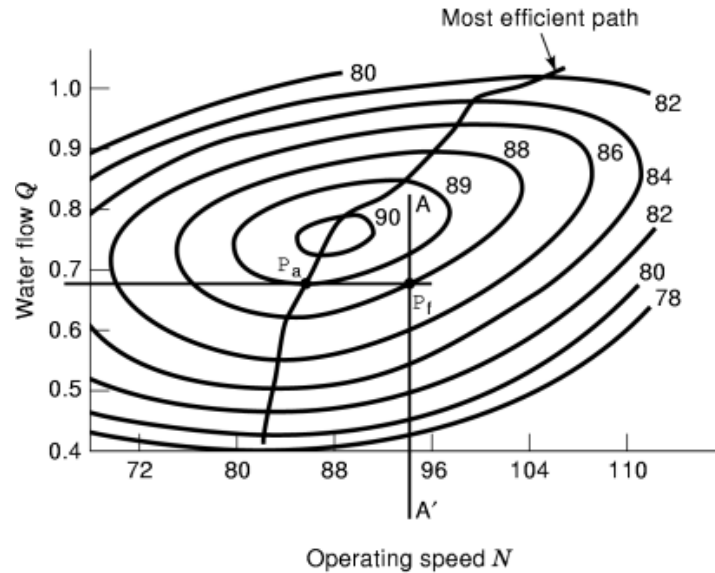

Fig. 3. Normalized hill curves. AA' defines the fixed-speed operating range for a given head as normalized flow (and power) change. Copyright International Water Power and Dam Construction. Used with permission.

Increased energy generation is derived directly from the hill chart curves in Fig. 3. The vertical line AA' defines a certain fixed-speed operation range, as flow and output power vary, and P_f an operating point for that speed. Adjusting the operating speed to move from point P_f to operating point P_a increases the power output in this case by 1% at no cost. The increased efficiency coming from a less turbulent water flow also results in inherently quieter operation and makes the unit less prone to vibrations and/or cavitation. If operation is constantly optimized for efficiency in this way, net energy gains are obtained (see Ref. 1, Chap. 3).

In addition to increased efficiency, environmental benefits, such as improved survival rates for fish passing through the turbines, are also achieved. Furthermore, a new approach to reservoir planning and design is possible if energy gains are traded for flooded areas (see Ref. 1, Chap. 3).

Figure 4 shows normalized turbine performance curves corresponding to an actual Francis runner design in the 700 MW range at a net head of 80 m. For adjustable speed operation at rated head, the turbine efficiency at part load increases substantially over fixed-speed operation. The peak efficiency changes only slightly, and the efficiency for rated conditions is identical. Of course, with a large number of units it is possible to operate at near peak efficiency over a large power range by simply scheduling the number of units in operation. Increased efficiency with adjustable speed at rated head and part load, in this example, would be most beneficial for a station with a small number of large units.

From Fig. 4 it can also be seen that adjustable speed operation at low head allows the turbine efficiency at part load and the available peak power to increase quite dramatically compared to fixed-speed operation. In addition, the turbine output and efficiency near full load are virtually identical for both maximum and minimum head. This efficiency increase is obtained only with adjustable speed. For fixed-speed operation at minimum head and part load, draft tube pressure oscillations and resulting shaft torque fluctuations are possible. This zone is avoided by adjustable speed operation.

The Limestone generating station on the Nelson River in Canada has 10 propeller turbines rated at 125.4 MW at a rated head of 27.6 m and a speed of 90 rpm. The turbines operate at constant speed and supply power to a conventional HVDC system. In view of future developments on the same river, adjustable speed operation has been studied in a hypothetical unit-connected system. Figure 5 shows the normalized performance curves

6 HYDROELECTRIC GENERATORS

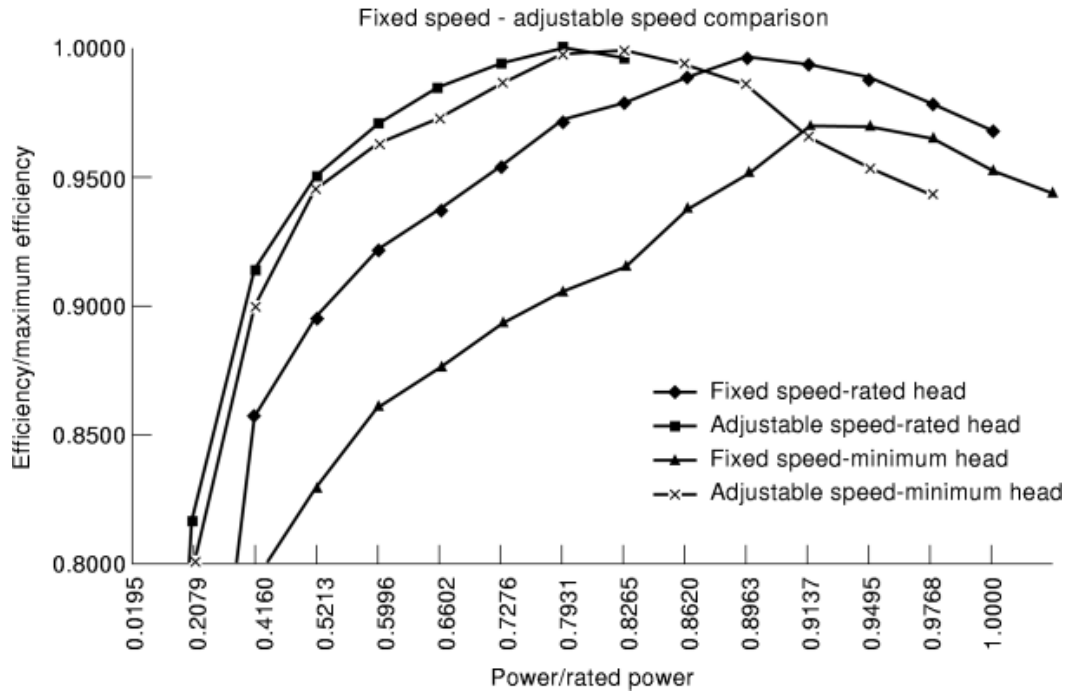

Fig. 4. Fixed-speed/adjustable speed comparison. Normalized performance curves for a 700 MW Francis turbine. Copyright International Water Power and Dam Construction. Used with permission.

for this plant with maximum speed variations of 5%, 10%, and 15%. The performance curve of a Kaplan turbine is superimposed for reference. The efficiency range for the Kaplan turbine is larger than the adjustable speed propeller turbine with a 15% speed range, but its capital and operating costs can be on the order of 30% greater.

The potential advantages of operating over a range of speeds are significantly different for the various standard turbine types as follows:

- Very low specific speed (high-head Pelton wheels). Practically no advantage to be expected from this type of development.
- Low specific speed (high-head Francis). Head variations in percent are small. Some efficiency gains can be obtained. Pump-turbine units can benefit significantly for each mode of operation.
- High specific speed (low-head Francis and propeller). Head variations in percent are very significant. Speed adjustment can compensate for efficiency losses due to head variation and can be used to avoid or reduce cavitation.
- Very high specific speed (low-head propeller, Kaplan, and bulb). Head variations in percent are very significant, particularly for tidal schemes. Speed adjustment can compensate for efficiency losses and avoid or reduce cavitation. May allow fixed blade propeller design to be used instead of a more expensive (approx. 30% more) Kaplan design.

For more detailed information on hydraulic turbines, the reader is directed to Ref. 1, Chap. 3.

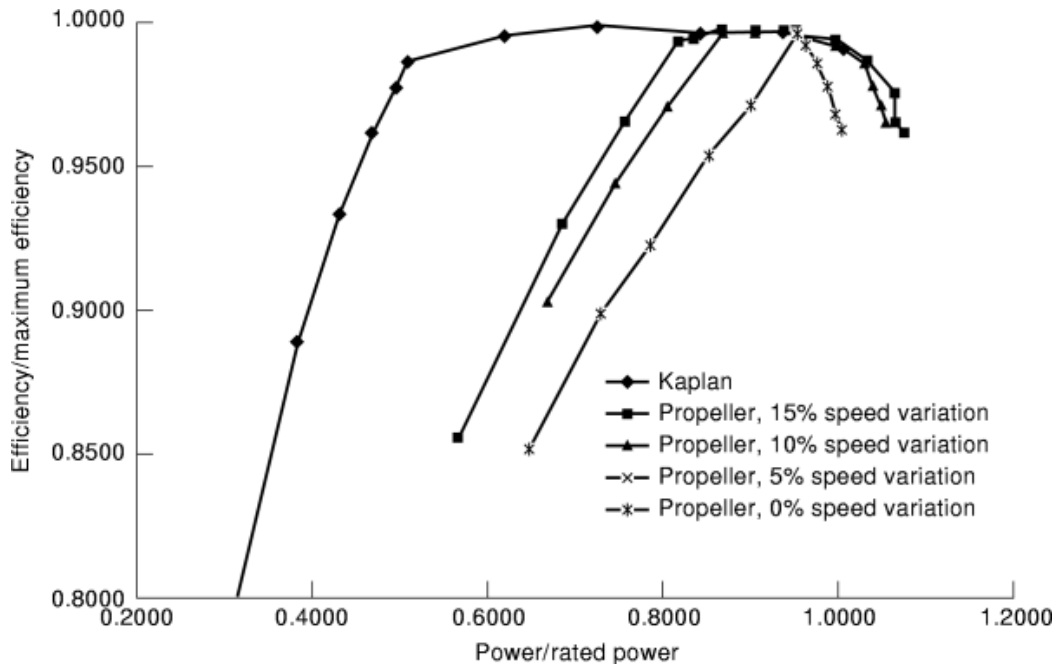

Fig. 5. Normalized performance curves for a Nelson River turbine at rated head compared to speed operation with speed variations of 0%, 5%, 10%, and 15%. The performance curve of a Kaplan turbine is shown for reference. Copyright International Water Power and Dam Construction. Used with permission.

Hydroelectric Generators

Conventional generators can be built for adjustable speed operation with only minor design modifications and modest cost increases. This can be done in unit-connected schemes for HVDC transmission systems, as previously described in this article, or with a combination of rectifier- and load-commutated inverter (*LCI*) equipment (also known as “back-to-back” HVDC connection). The latter method is used when the transmission system is ac and is generally close to the generating station. But because the LCI has the same rating as the synchronous machine, the cost is effectively increased by 75% to 110% due to the LCI equipment. In developments where conventional HVDC transmission is economically competitive or needed for other reasons (frequency conversion, for instance), however, an adjustable speed HVDC unit-connection solution imposes no overprice. Rather, in addition to all other inherent advantages of the adjustable speed mode of operation, it substantially reduces capital and operating costs.

Hydroelectric generators using adjustable speed is not a new subject. There are several examples of pumped-storage installations, particularly in Asia, with ac machines specially designed for adjustable speed pump-turbine operation (2). Some of these machines are “doubly fed,” that is, instead of a conventional dc excited rotor, they have a three-phase ac wound rotor which is fed by a “cycloconverter.” The purpose of this device is to provide an adjustable frequency supply to the rotor winding which then allows the rotor speed to vary while the rotating field in the stator remains at a standard ac system frequency. The cost of this type of machine is considerably higher than a conventional hydro machine (perhaps 50% to 90% more) because of the high cost of the rotor and excitation system.

This article discusses adjustable speed operation of conventional hydroelectric generators in HVDC unit-connection systems.

8 HYDROELECTRIC GENERATORS

General Assessment.

Harmonic Electric Loading. Conventional generators feeding ac systems are subjected to negative sequence current loading. The negative sequence current creates low-order harmonics as a result of rotor saliency. Hence, generators are designed to have additional thermal capacity to sustain 8% to 12% of negative sequence current loading. Generators feeding only HVDC converters in the absence of dc line current second harmonics (the normal steady-state operating condition) see virtually no negative sequence loading. Thus the additional rating can be used to compensate for the 12-pulse harmonic electrical loading (6).

Torque Harmonics. The presence of pulse-number-related frequencies in the rotor (i.e., multiples of 600 Hz for a 50 Hz fundamental frequency) will cause a small electromechanical torque of a few percent. Although high in the context of large machines, such frequencies might excite natural modes of resonance either in small components or, because of nonlinearities, might induce subharmonic vibrations in larger components.

Adjustable Speed Operation of Hydro Generators. At a higher speed n (rpm), machine operation will take place at a correspondingly higher frequency f (Hz). Stray losses due to windage, mechanical friction, and harmonics increase. However, there is only a minor influence on the overall electrical efficiency for the small increases in speed required to optimize energy conversion in hydro turbines. The case of downward speed changes requires more attention as it may impose some additional capacity on excitation circuitry if full voltage is required at minimum speed.

Basic Design Frequency and Speed. The present day switching speed of high power electronic devices, especially the parameters associated with the current extinction process, allows HVDC converters to operate at up to about 120 Hz.

Vibration and Noise. The full pole-pitch, air-gap flux components caused by current harmonics can interact with each other and with other components of air-gap flux in a rather complicated way, causing vibration forces and contributing to increased noise level.

Generator Power Factor. The absence of ac filters leads to unit-connected generator operation with very high fundamental frequency power factor values, as seen from its terminals, typically 0.9 to 0.94. In the limit, for a hypothetical transformerless unit connection, the generator terminal fundamental frequency power factor is reduced, as a first approximation, to the cosine of the firing angle “ α .” This is so, because the ideal commutation voltage moves inside the machine. Given the comparatively high frequency of commutations (12 per cycle), the voltage behind subtransient reactance, with good approximation, is the new commutation voltage (see Ref. 1, Chap. 4). In practice, internalizing the commutation voltage relieves the machine from about half the total converter reactive power requirement that it would otherwise have to provide.

Fundamental Frequency-Generator/Converter Interaction. The commutation process is a short circuit between two phases of the generator across the transformer leakage reactance x_t that lasts for only about 20 electrical degrees. The commutation reactance x_c for a unit-connection arrangement is given by Eq. (1). x'' is the actual operating point subtransient reactance of the generator, x_t the transformer leakage reactance, and x_c the commutation reactance in ohms at the transformer base:

$$x_c = x_t + \frac{1}{2}x'' \quad (1)$$

The commutation has two main effects on the operation of a unit connection. One is detrimental in that it creates an ohmic drop of the dc voltage in which the commutation reactance plays the part of a nondissipative resistance. The greater x_c , the greater the loss of voltage:

$$\frac{\Delta U_d}{U_d} = \frac{1}{2} \cdot x_c \cdot \frac{I_G}{U_G} \quad (2)$$

where

ΔU_d = dc voltage drop in volts

U_d = dc voltage in volts

I_G = generator current in amps

U_G = generator voltage in volts

The other main effect of commutation is beneficial in that operation with somewhat longer commutation periods reduces harmonic distortion and the fast transients that are detrimental to the stator winding insulation.

The addition of the subtransient reactances to the commutation circuit increases the commutation reactances compared with conventional arrangements.

Reactance Variation with Speed.

Operation with Constant Flux. When the generator operates with constant flux ($U/f = \text{constant}$), the voltage and the frequency vary proportionally with the speed, and the generator current remains constant. In this case, all of the generator reactances and the transformer leakage reactance vary proportionally with the frequency. Therefore, so does the commutation reactance given by

$$x_c = K \cdot f \quad (3)$$

For a given firing angle, the angle of commutation and the voltage drop of the dc voltage are constant:

$$\frac{\Delta U_d}{U_d} = \frac{1}{2} \cdot x_c \cdot \frac{I_G}{U_G} = \frac{1}{2} \cdot K \cdot f \cdot \frac{I_G}{U_G} = \frac{1}{2} \cdot \frac{f}{U_G} \cdot K \cdot I_G \quad (4)$$

Operation with Adjusted Flux ($U_G = \text{Constant}$). In this case, generator power is proportional to speed implying that I_G has to vary with frequency ($I_G = K'f$) and to the commutation reactance x_c . The inductive voltage drop becomes proportional to f^2 :

$$\frac{\Delta U_d}{U_d} = \frac{1}{2} \cdot x_c \cdot \frac{I_G}{U_G} = \frac{1}{2} \cdot K \cdot f \cdot \frac{K'f}{U_G} = \frac{KK'}{2} \cdot \frac{f^2}{U_G} \quad (5)$$

The per unit voltage drop increase with the square of the frequency is of little concern at higher speeds because generated voltage can easily be increased through modest flux adjustments in such a situation. At low speeds, the per unit voltage drop reduction at a quadratic rate is beneficial in that less overflux is required to keep the generated voltage at rated levels.

Typical Values of Commutation Reactances for 12-Pulse Unit Connection. The subtransient reactance seen by the commutation circuit during operation of a unit connection is a nonlinear function of direct and quadrature axis reactances, dependent on the actual air-gap flux magnitude and spatial orientation at the specific operating conditions. For planning and station design, the subtransient reactance x'' of hydro units can be evaluated from the negative sequence reactance x_2 . For a generator equipped with a continuous damper winding, the values of the reactances x''_d and x''_q are very close (within 10%), and the following approximation is suggested:

$$x_2 \approx \frac{x''_d + x''_q}{2} = x'' \quad (6)$$

In practice, the value of the transformer reactance based on the transformer rating is about half that of the subtransient reactance, and so with interpolar damper connections the commutation reactance approximates

Table 1. Upper Limits of 12-Pulse Unit-Connection Commutation Reactances^a

μ	α	$x''\%$	$x_t\%$	$x_c\%$
28°	10°	20.0	9.7	19.7
28°	15°	20.0	13.4	23.4
28°	20°	20.0	17.1	27.1

^aWithin the usual firing angle ranges and corresponding to conventional combinations of subtransient and transformer leakage reactances.

the subtransient reactance:

$$x_c = x_t + \frac{x''}{2} \approx \frac{x''}{2} + \frac{x''}{2} = x'' \quad (7)$$

For 12-pulse thyristor converters at rated frequency, the figures shown in Table 1 apply. For firing angles (α) between 10° and 20°, the commutation angle μ can be kept under 30° for standard values of transformer leakage and generator subtransient reactances. The 30° limit must be obeyed in principle in steady state to avoid the reduction of dc voltage brought about by simultaneous commutations. As 10% leakage is economically achievable in practice, the commutation reactance can be set around 20% with ease and the commutation angle kept well below 30° for thyristor bridge unit connections. When diodes are used, the nominal firing angles become practically zero, and the commutation angles increase substantially. In this case, either lower subtransient and transformer reactances are selected, or operation with forced retard (i.e., with reduced dc voltage and a commutation angle equal to 30% at full load) is accepted.

Damper Winding. Interpolated damper connections are sometimes avoided to improve the mechanical reliability of salient pole rotors. However, for a machine equipped with a noncontinuous damper, x''_q increases and reaches a value of about $1.5x''_d$. This causes an increase in x_2 of about 25%. Therefore, for a machine constructed with noncontinuous damper connections,

$$x_c = x_t + \frac{x''}{2} \approx \frac{x''_d}{2} + \frac{1.25x''_d}{2} = 1.125x''_d \quad (8)$$

Suppression of the interpolar damper links increases the value of the commutation reactance x_c by about 12.5%. This also increases subtransient saliency and may allow a higher proportion of stator harmonics to penetrate the rotor circuits, resulting in increased losses, vibration, and noise. Therefore full cage damper circuits are highly recommended for HVDC unit-connected systems.

Reactance Variation Due To Machine Load. All reactances in a generator vary with the machine state of saturation. The corresponding effect on x_c , however, is about 1%, which is negligible.

The variation of frequency does not affect the reluctance of the magnetic circuit significantly over the considered range. Therefore, x_c is practically constant in the working range for constant U/f . However, if full voltage is required at minimum speed, that is, U/f is increased because of overexcitation, saturation may increase, and the subtransient and commutation reactances are reduced.

Influence of Damper Resistance. In a generator connected to a converter, the effectiveness of the dampers is more important against the stator current harmonics. The skin effect increases the resistance of the dampers by about 30% within the range of 45 Hz to 75 Hz. However, their resistance is less than 1% of the value of the reactance x''_d , and so the increase is equivalent to about 0.3% of x''_d . Thus damper resistance can be disregarded in the context of commutation analysis.

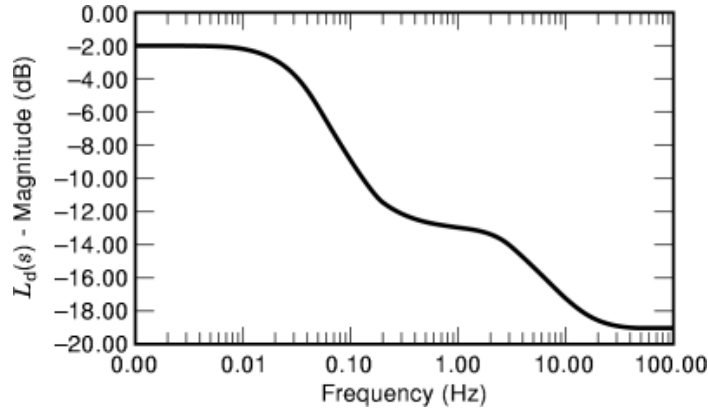

Fig. 6. Bode diagram of L_d for a 60 Hz, 194.4 MVA hydro generator.

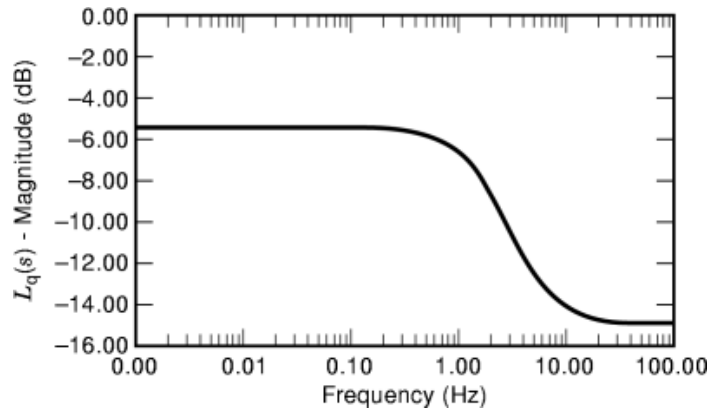

Fig. 7. Bode diagram of L_q for a 60 Hz, 194.4 MVA hydro generator.

Generator Frequency Response. Figures 6 and 7 are Bode diagrams of direct [$L_d(s)$] and quadrature [$L_q(s)$] axis operational inductances plotted from the actual direct and quadrature axis parameters, obtained by standard testing of a salient-pole, 194.4 MVA, 13.8 kV hydro generator. The horizontal axis refers to slip frequency seen by the rotor (see Ref. 1, Chap. 4).

The diagrams can be derived from a larger number of time constants, if the relevant test information is available. This corresponds to a larger number of rotor circuits when deriving the equivalent circuit and to a correspondingly larger number of operational inductance poles and zeros. The characteristic asymptotic behavior consisting of ever lower “plateaus” remains, nevertheless, unaltered in shape.

It is very relevant to note from this example that stator harmonics coupled with rotor frequencies of only about 50 Hz and up already see operational inductances that remain constant over the speed ranges considered for HVDC unit-connected stations. The lowest stator winding frequencies associated with converter operation induce slip frequencies of at least fundamental frequency. Therefore, it can indeed be safely considered that all machine reactances associated with the commutation process vary linearly with speed.

Generator Excitation. The most commonly used and simplest system for generator excitation is the shunt arrangement. This system is well suited to operation under a constant U/f (voltage/frequency). A field flashing system from a battery can be used to provide power to start up the excitation system. When the

12 HYDROELECTRIC GENERATORS

generator is required to operate with constant (rated) voltage over the entire range of speed/frequency, it may be necessary to oversize the excitation system to allow the generator to operate at low frequencies.

Auxiliary Three-Phase Generator. Oversizing may be avoided by using an auxiliary three-phase synchronous generator coupled to the main unit shaft. This auxiliary generator, provided with a shunt excitation system and with a field flashing system, supplies the main generator excitation. Because it operates with a constant U/f , the excitation transformer does not need to be oversized.

Fully Independent Auxiliary Generators. In large, multiunit hydro stations, it may be more convenient to provide smaller independent hydro units to feed the excitation systems, station auxiliaries, and local loads. In this way all effects on auxiliaries caused by harmonics in the station supply and by the frequency variations are eliminated.

Cycling and Fatigue. Excessive cycling of machines over significantly varied operating conditions may lead to premature aging and even to failures. Designers usually consider the influence of voltage, frequency, and load variation. The last two have a direct bearing on operating temperature. The amplitude of the cyclic variations and its periodicity are the key variables for each parameter considered.

Terminal voltage suffers some comparatively high-frequency distortion originated by the commutations over the operating life of the machine. In principle this could lead to premature aging of insulation. It is of little concern, however, in filterless, natural commutation, 12-pulse operation.

Speed/frequency cycling could be seen as the major cause of concern due to adjustable speed HVDC unit-connection operation. However, it is characterized by periods of at least hours in a certain load and speed regime followed by a slow, controlled transition to the new operating point. The duration of a full operating cycle varies from a few hours in pump storage stations to several days in most generating stations, corresponding to about a thousand cycles or less per year. The amplitude of the speed adjustments are site-dependent, but simulations of practical cases indicate that they are likely to remain within $\pm 10\%$ for the majority. From present experience, this additional duty does not require major design modifications or change of rotor materials.

Stator Winding Insulation. When repetitive impulse voltages reach a winding, the voltage distribution along the winding is initially nonlinear and overstresses turn and ground insulation of the first coil. If the stress is close to the partial-discharge (PD) inception voltage, electrical aging of the insulation may occur. In the past the evaluation of insulation aging by impulse voltages has been studied to determine its endurance against lightning surges or the fast switching surges originated by restriking breakers, especially vacuum types. The number of pulses in this concern is limited, however, by comparison to the number of impulses inherent in converter operation. Frequent repetition of relatively low-peak voltages is the special feature of converter operation. Therefore it is essential to carefully study and evaluate the transients and waveforms expected in the actual station arrangement during the design stage in close cooperation with equipment manufacturers for both cold and hot machines, given that dielectric characteristics vary with temperature (5).

The insulation system of large machines is made of form-wound windings consisting of turn insulation and micaceous ground insulation. In conventional ac operation, the voltage applied to the turn insulation is far lower than the PD inception voltage because the voltage distributes itself uniformly along the entire winding. In high switching frequency converters, the insulation of the first turn can be highly stressed by impulses. Fortunately, however, for generator sizes above 30 MVA, single turn coils are normal, and so turn insulation problems are of concern only in smaller machines. In addition, large machines are always operated with converter transformers. In schemes such as these, the fast component is blocked, and only a distorted ac voltage, comprising mainly slow repetitive components, is applied to the windings. Poor circuit configuration and faulty station design, however, can allow fast impulses to be greatly amplified, especially between the generator and the converter transformer, by successive reflections due to abrupt changes in surge impedance. Special design care in this area is necessary.

Generator Losses.

Windage Losses. If the generator speed range is not too large, the unit can be self-ventilated. Then windage losses are proportional to the third power of speed. When the generator cannot be self-ventilated at low speeds, however, a forced cooling system may be required to support ventilation.

Iron Losses. This is a common designation for a number of phenomena of different natures in the iron core. They can be split up roughly as “eddy current losses” and “hysteresis losses.” For 0.5 mm laminations in delivery condition and at 50 Hz, for instance, the eddy current losses measured according to the Epstein method are about 33% of the total losses. Consequently, the hysteresis losses correspond, in this case, to the remaining 67%.

Eddy Current Losses. This is a collective name for losses caused by eddy currents within the laminations themselves and by eddy currents circulating between laminations and some other solid or structural components of the core. Eddy current losses vary roughly in proportion to the square of both induction and frequency ($\approx B^2$, $\approx f^2$).

Hysteresis Losses. These relate to the area within the B/H characteristic of the core material and vary roughly in proportion to frequency ($\approx f$). The relationship between induction and hysteresis losses is very complicated as it depends on both space and time variations of the induction. For strictly pulsating induction, the hysteresis losses vary roughly with the square of the induction ($\approx B^2$). For strictly rotating induction, losses have a maximum for some critical value of B after which they decrease with increasing B .

For design and construction, different manufacturers use somewhat different practices, but now the actual design of very large machines is supported by sophisticated CAD packages that usually rely on finite-element techniques for accurately considering flux patterns and current eddies. Small machines may still be adapted from previous, well-known designs, to reduce escalating engineering costs. Most machine phenomena, however, can be simplified when doing preliminary estimates and so can iron losses. The following relationship is suggested:

$$P_{Fe} = P_{Fe0} [k_h (f/f_0) + (1 - k_h) (f/f_0)^2] (B/B_0)^2 \quad (9)$$

where

P_{Fe} = the total iron losses

P_{Fe0} = the total iron losses at rated frequency and nominal induction

f = the actual frequency under consideration

f_0 = the rated frequency

B = the actual induction under consideration

B_0 = the nominal induction

k_h = the hysteresis share of P_{Fe0}

This expression is a fair approximation for $0 < B < B_0$ when f varies between 25 Hz and 65 Hz and f_0 varies between 40 Hz and 60 Hz. The numerical value for k_h depends, among other things, on machine design and lamination treatment during the manufacturing process. The value is usually 0.5 for 0.5 mm steel lamination, because it is typical that the eddy current loss share increases from the previously mentioned value of 0.33 for steel laminations before machining processes to about 0.5 after the machine is completed. The iron losses due to voltage harmonics are low and are neglected in the present context.

Stray Losses in Stator Copper. In the windings of ac machines, the transverse flux in the slots creates supplementary losses by skin effect in the copper strands in addition to joule losses. When the generator is connected to a converter station, the phase currents contain many harmonics that cause supplementary losses. These can be computed similarly to those corresponding to the fundamental frequency and have significant values up to the 25th. These losses are proportional to the square of the frequency (f^2).

14 HYDROELECTRIC GENERATORS

Losses in Pole Shoes and Damper Windings. Stator current harmonics create variation of the induction in the air gap and cause losses in the pole shoes. These losses can be made negligible in the iron by using laminated steel sheets to manufacture the rotor poles. The losses created in the damper windings by the harmonics are computed as for an asynchronous machine (up to the 25th harmonic). These losses may be high enough in certain operating conditions to cause overheating of the damper windings. Short-circuiting rings must be designed to allow free damping-bar thermal expansion.

Generator Rating. The generator terminal power factor in unit connection is typically higher than that for a conventional HVDC arrangement of similar characteristics over the entire range of operation. In addition, as shown in 1, Chap. 4, a generator rated to provide maximum power at base speed is overrated for adjustable speed operation duty because maximum power is provided only at maximum speed.

Generator Rating at Fixed Speed. The generator MVA rating for 12-pulse operation is given by

$$S = k_H \frac{P_d}{\cos \phi_{t_1}} \quad (10)$$

where k_H is a factor that allows for harmonic VA demand due to the rectifier load. It varies with operating parameters (firing and commutation angles, full or partial load) chosen to specify the rating point but is only a fraction of a percent for large 12-pulse unit connections. Reference 6 recommends values of 1.01 for twelve-pulse and 1.05 for six-pulse operation. Reference 1, Chap. 4, considers these numbers typical for laminated pole construction. P_d is the dc power of the rectifier load connected to the generator, and ϕ_{t_1} is the fundamental frequency power factor angle seen from the generator terminals. *The converter fundamental frequency power factor angle should not be used here because now the commutation voltage is internal to the generator.* The values to be used are approximated within a few percent by

$$\cos \phi_{t_1} \cong \cos \alpha - \frac{\chi_t}{2}$$

which corresponds to extracting the generator subtransient reactance from the converter commutation reactance. This approximation is usually acceptable for planning and specifications (see Ref. 1, Chap. 4 for a more detailed discussion).

Generator Rating at Adjustable Speed. The usual definition of the nominal MVA of the generator is given by

$$S_{GN} = \sqrt{3} \cdot U_{GN} \cdot I_{GN} \quad (11)$$

where the subscript N indicates nominal (rated) values, U_{GN} = rated generator voltage and I_{GN} = rated generator current. It has to be adapted for operation at adjustable speed by

$$S_{GV} = \frac{\sqrt{3} \cdot n}{n_N} \cdot U_{GN} \cdot I_{GN} \quad (12)$$

where n_N = generator rated speed. No consideration is given here to the fact that iron and copper losses caused by the skin effect are frequency-dependent, with the consequence that at $n < n_N$ a higher induction, $U_G > n/n_N \cdot U_{GN}$, is acceptable in a first approximation.

The generator rating for adjustable speed operation must be derived from the most demanding conditions over the range of operating points which are defined by the actual requirements for the specific development. The ideal requirements are reduced voltage at the lowest speed and maximum power only at highest head and

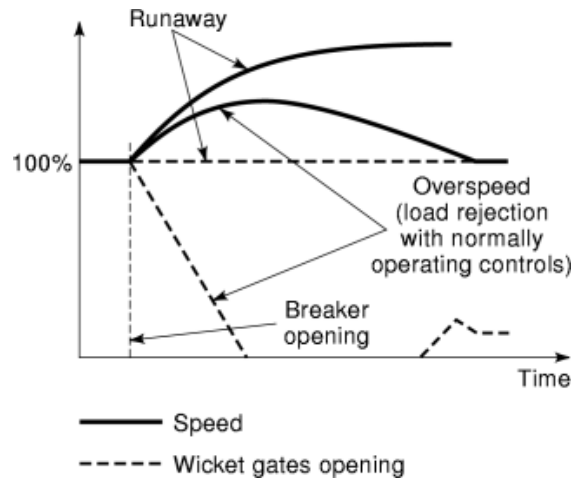

Fig. 8. Runaway and overspeed curves for hydro generator sets.

speed. This may not be always the case, however, and so the actual operating conditions must be investigated to identify all limiting requirements that do not correspond necessarily to just one operating point. The need to absorb 12-pulse harmonic loading must be combined with the actual negative sequence loading expected from the small imperfections of the actual equipment, and the need for increased excitation must be checked against reduced losses at lower speeds.

Generator Voltage. It is generally required in ac and in dc systems that generators maintain an almost constant voltage over the full operating range. This requirement cannot be fulfilled by a generator whose rated power is required at maximum speed and is operated with constant flux. However, as mentioned above, higher induction can be accepted at lower speeds, and if the generator current is also reduced in proportion to the voltage increase, a design compromise becomes easier at the lower end of the speed range, with no or only a marginal overrating at base speed.

Generator Inertia Parameters (GD^2). Generator inertia parameters are important because, together with the hydraulic circuit and turbine design, they define the overspeed transient peak. Figure 8 is a diagram showing the wicket gates closing after a load rejection in conditions of runaway speed and overspeed. Runaway occurs when the turbine is left with no load at maximum head and fully open wicket gates. It is a steady-state condition with zero efficiency, and speed is directly proportional to the square root of the head. A total loss of governor control leads to runaway. The time to achieve runaway speed increases with the inertia. Design standards require that hydro generating sets be built to withstand runaway conditions without structural damage.

Overspeed, on the other hand, is the peak velocity of a controlled machine during a load rejection transient. The slower the wicket gate closing action, the longer the machine accelerates toward runaway, and the greater the overspeed. The larger the generating set inertia, the smaller the acceleration, and the smaller the overspeed.

It is reasonable to question the limits of overspeed that can be specified for unit-connected generators. The so-called “natural” inertia of the generator, which results from electrical and mechanical design considerations and is adequate for stability of speed regulation, should be checked first. After that, load rejection simulations and structural analysis of the generator and exciter mechanical components at the corresponding overspeed and runaway conditions must be performed to see if any limit is violated. Eventually some small increase in inertia may be required, but it is likely that a lighter and less costly, nearly “natural inertia” design would be acceptable.

New Zealand Field Tests. The New Zealand HVDC system was made available for harmonic tests during two periods of converter transformer maintenance in 1993 and 1995. Under these conditions, the sending-end HVDC poles and ac filters were disconnected from the ac system. Operation was uneventful as a “group connected” unit connection (4). Waveform distortion measurements confirmed the theoretical predictions, and the generator operating parameters, such as temperature, vibration, and noise, remained within normal limits.

Other Considerations

Converter Transformers. The HVDC unit-connected converter transformer performs the functions of the generator and HVDC converter transformer in a conventional scheme. In the absence of an ac system at the generating station, the unit connection does not have to maintain a constant ac voltage or frequency at the generator terminals. Therefore, control of the rectifier ac voltage, with the function of keeping the firing angle within the specified range, is achieved directly by generator excitation control without the need for a transformer on-load tap changer (*OLTC*) required in a conventional system. Eliminating the *OLTC* reduces the cost of the transformer by 20% to 30%, improves reliability, and reduces maintenance. For a frequency variation of $\pm 10\%$, the transformer cost increases by about 6.5%, giving a net cost reduction of approximately 14% to 24% (see Ref. 1, Appendix 8).

When a unit-connection scheme is operated with adjustable speed, the design of the transformer takes into account the resulting frequency range. In most cases, the maximum frequency corresponds to the maximum power, and hence the maximum MVA rating is determined. At lower frequencies core saturation might require some core oversizing. This is beneficially offset in most cases, however, by a reduced turbine load caused by reduced head conditions.

Speed Regulation. A HVDC rectifier load is unique in that it lacks inertia, is frequency insensitive, and in many cases is also insensitive to the rectifier voltage. In turn, when an HVDC scheme is operated at a fixed power order, isolated machines feeding the rectifier are subject to a torque load that varies inversely with frequency. To control the speed of the units in a unit-connected system, there must be a clear understanding of the intended system operation. The speed control should order the units to operate at maximum efficiency for the given machine loading, dictated by the dc power order and the head.

Several requirements have been identified in analyzing speed regulation for a unit-connected system, and the following conclusions have been drawn (see Ref. 1, Appendix 5):

- System damping requirements are very critical. Therefore, proper governor settings are extremely important.
- An auxiliary sending-end dc damping control is not required for sending-end stability.
- An auxiliary frequency control acting through the governor load setter is required for plant frequency control and for operation at the highest achievable frequency for the system load and head.
- Higher overspeed for loss of dc control should be considered.
- A dc capability control would prevent any excessive underfrequency conditions.

Overall, there are no technical difficulties that cannot be overcome for speed regulation in a unit-connected HVDC scheme operating within a speed range of approximately $\pm 10\%$.

Modeling. When investigating new concepts, such as adjustable speed HVDC unit-connection schemes, it is essential to model the complete system to evaluate the consequences of system effects on the generator and the effect of the generator on the system. This involves developing modeling techniques to simulate the generator, the hydraulic system, and the electrical system to which the generator is connected. Thus, consideration must be given to the level of modeling required if meaningful results are to be obtained. For

instance, if the effect of the converter harmonics on generator heating is required, then a more complex generator model has to be used than when control strategies or system disturbances are to be investigated. The main difference between conventional and unit-connected HVDC systems is that the generators are much closer to the converters in the latter.

In nearly all cases simulation tools are available and, in most cases, provide results that are accurate within the bounds of accepted practice. For example, if information on localized internal effects of the HVDC system on the generator is required, a complex model based on finite elements can be used.

Overall, it is essential to realize that the major electrical components of a HVDC unit-connected scheme form a closely knit system where mutual interactions are very relevant. Hence, integrated studies choosing adequate simulation tools are recommended (see Ref. 1, Chap. 8).

Station Auxiliaries. Station auxiliaries may be supplied directly from a separate power source, such as small hydraulic generators, in which case power quality is assured. Alternatively, station auxiliaries may be supplied from the main generators but will be subject to some voltage distortion and frequency variation. The selection of all powerhouse auxiliary equipment should be properly considered in designing for this option.

Overall Performance. In principle, the stability and operational reliability of unit-connected HVDC systems using thyristor valves is inherently better than conventional HVDC systems. The following are the main issues (see Ref. 1, Chap. 7):

- The absence of ac filters drastically reduces the amount of energy stored in electromagnetic fields. This energy would be liable to oscillate within the station circuitry in the event of control actions, perturbations, and faults. Many station oscillation modes at harmonic and subsynchronous frequencies are, therefore, eliminated, together with the risk of generator self-excitation.
- The elimination of on-load tap changers. When used in conventional systems, they induce perturbations and overvoltages. They also have high maintenance requirements so that their removal improves reliability and reduces costs considerably.
- The wide separation in the magnitude of dominating natural frequencies of turbine, generator excitation, and converter valve firing controls makes it comparatively easy to reach optimum adjustment.
- There is a remarkable increase in sending-end controllability compared with conventional HVDC stations. This is important when modulating power to improve receiving-end system damping and/or frequency control.
- Eliminating ac filters greatly improves the station dynamic behavior and virtually eliminates overvoltage stresses due to harmonic distortion. Generator speed/frequency swings of large magnitudes do not lead to disturbances of the firing sequence or to voltage distortion. There are no filters to be lost by protection action, and consequential faults cannot develop.
- Fast accurate control of power flow in steady state and during power swings is one of the most important characteristics of HVDC systems in large interconnected power system operation. Thus, should this modulation duty be required as a major characteristic, adequate margins must be considered and allowed for at the design stages.

Diode-Equipped Rectifiers. In the foregoing discussion, it has been assumed that the rectifiers and inverters of the HVDC unit connected system are equipped with thyristors and that the sending-end rectifier controls the direct current in the transmission line. There is, however, no doubt that direct current control can also be performed by an inverter. In this case, the rectifier can be equipped with diodes, which promises further major cost reductions in equipment and losses and increased reliability and reduced maintenance. The need for rectifier controls and associated communications equipment is also drastically reduced. On the other hand, an important protection function of the rectifier current control is lost, as well as the overcurrent limitation and fast clearing of line faults.

18 HYDROELECTRIC GENERATORS

The application of diode-equipped rectifiers requires further assessing the need for dc circuit breakers in the transmission line (see Ref. 1, Chap. 6).

Acknowledgments

In response to the need for an evaluation by generator specialists of the subject of unit connection and adjustable speed concepts, Conference Internationale Des Grand Reseaux Electriques A Haute Tension (*CIGRÉ*) Study Committees 11 (Rotating Machines) and 14 (HVDC links and ac power electronic equipment) created Joint Working Group (*JWG*) 11/14.09 in 1989. The following are the *JWG*'s main objectives:

- Identify the main factors to be considered for specification and design of unit-connected generators.
- Propose parameters and performance indexes for comparison with conventional arrangements.
- Review modeling possibilities for the study and design of systems containing unit-connected stations.

In 1993, the additional objective of defining the characteristics and advantages of adjustable speed operation was added. The final *CIGRÉ* report was published in August, 1997, entitled *Guide for Preliminary Design and Specification of Hydro Stations With HVDC Unit Connected Generators*, Technical Brochure No. 116, item (1) in the bibliography.

The technical brochure recognizes all individuals and corporations, too numerous to list here, who contributed to the study's success. Interested readers are encouraged to review this report for further information.

BIBLIOGRAPHY

1. *CIGRÉ JWG 11/14.09, Guide for Preliminary Design and Specification of Hydro Stations with HVDC Unit Connected Generators*, Technical Brochure, No. 116, 1997.
2. D. A. Green, Generating more efficiently with adjustable speed machines, *Hydro Rev.*, **13**: 18–27, April 1994.
3. L. Ingram, A practical design for an integrated HVDC unit-connected hydroelectric generating station, *IEEE Trans. Power Deliver.*, **3**: 1615–1621, 1988.
4. S. J. Macdonald *et al.*, Test results from Benmore HVDC station with the generators operating in group connected mode, *IEEE Winter Power Meet.*, **95 WM**, New York: SPWRD, 1995, pp. 242–248.
5. C. Mubemba, K. J. Cornick, The analysis of fast-fronted switching surges in machine windings-effect of dielectric losses, *Trans. South Afr. EE*, **86** (2): 57–64, 1995.
6. P. C. S. Krishnayya, Block and double block connections for HVDC power station infeed, *IEEE PES Summer Power Meet. and EHV/UHV Conf.*, Vancouver, Canada, 1973.

READING LIST

- J. Arrillaga, J. G. Campos-Barros, H. J. Al-Khashali, Dynamic modelling of single generator connected to HVDC converters, *IEEE/PAS*, **97** (4): 1978.
- J. Arrillaga *et al.*, Characteristics of unit connected HVDC generator converters operating at variable speeds, *IEE Proc.-C*, **139** (3): 295–299, 1992.
- J. Arrillaga *et al.*, Harmonic elimination by dc ripple reinjection in generator-converter units operating at variable speeds, *IEE Proc.-C*, **140** (1): 57–64, 1993.
- D. S. Bajwa, R. M. Mathur, Re-rating of synchronous generators supplying HVDC converters with special reference to unit connections, *IEEE Canadian Conf. Commun. Power*, Montreal: 1976.
- J. P. Bowles, HVDC Systems development and concepts-the diode rectifier, *CIGRÉ SC 14 Meet. Colloquium*, Winnipeg, Canada, 1977.

- CIGRE JWG 11/14.09, Study of the application of HVDC variable speed unit connected generators to hydro developments in the Brazilian Amazon region, *CIGRE Int. Colloquium, HVDC and FACTS*, Wellington, NZ, 1993.
- CIGRE JWG 11/14.09, Hydro generators reactances and power factor in HVDC unit connection, *Int. Colloquium HVDC FACTS*, Montreal, Quebec, Canada, 1995.
- CIGRE JWG 11/14.09, Adjustable speed operation of hydro electric turbine generators, *Electra*, 167: August, 1996.
- EPRI Report RP3577-01, Application of adjustable speed machines in conventional and pumped-storage hydro projects, 1995.
- K. W. Kanngiesser, Unit connection of generator and converter to be integrated in HVDC or HVAC energy transmission, *Int. Symp. HVDC Technol.*, Rio de Janeiro, Brazil, 1983.
- E. Kita *et al.*, A 400 MW adjustable speed pumped storage system, *Water Power and Dam Construction*, **43**: 37–39, Nov. 1991.
- L. Ingram *et al.*, Adjustable speed hydroelectric turbine/generators, *Water Power and Dam Construction*, **47**: 40–42, July 1995.
- G. Merouge, M. Denoncourt, Variable speed hydraulic generators, *CIGRE Int. Colloquium on HVDC Power Transmission*, Recife, Brazil, 1989.
- M. Naidu, R. M. Mathur, Evaluation of unit connected variable speed hydropower station for HVDC power transmission, *IEEE Trans. Power. Syst.*, **4**: 668–676, 1989.
- R. D. Rangel, A. S. Pedroso, J. G. Campos-Barros, Dynamic performance of salient pole unit-connected generators, *Int. Colloquium on HVDC Power Transmission*, CIGRE, Recife, Brazil, 1989.
- L. B. Reis, M. A. Saidel, Operation at adjustable speed: Prospectives of higher energy efficiency and better environmental integration for hydroelectric plants, *Int. Symp. Electr. Power Eng.*, Stockholm, Sweden, June, 1995.
- H. Tanaka, An 82 MW Variable speed pumped-storage system, *Water Power and Dam Construction*, **43**: 25–26, Nov. 1991.
- L. Terens, Schafer, Variable speed in hydro power generation utilizing static frequency converters, *WATERPOWER-An Int. Conf. Hydropower*, Nashville, TN, 1993.

J. G. CAMPOS-BARROS
 Independent Consulting Engineer
 LINDSAY INGRAM
 Manitoba HVDC Research Centre