

## MUSICAL INSTRUMENTS

An electronic musical instrument can be defined as an instrument in which sounds are produced through some form of electronic generation rather than through the acoustic resonance of a vibrating body. More succinctly, electronic instruments produce musical sound waves electrically rather than mechanically.

The introduction of electrically generated sounds, linked with the application of that technology into the production and design of musical instruments, created a revolutionary way of thinking about the very nature of musical instruments. Whereas traditional acoustic instruments relied upon mechanically vibrating bodies to generate sounds, electronic instruments rely upon the oscillation of an electrical current to simulate a musical wave form. Nearly all of the electronic

instruments developed up to and through the 1970s relied upon the process of analog synthesis for the generation and manipulation of basic wave forms, or sounds. The 1990s, however, has seen the development of and nearly total reliance upon the use of digital synthesis. The reliance upon electronic signals, coupled with the hypothetically unlimited ability to manipulate those signals, stimulated a revolution in instrument design that is yet to abate.

This article is organized into several sections. It begins with a brief historical overview and description of the basic technology. This section is followed by a more detailed discussion of both analog and digital synthesis methods. The article concludes with a discussion of basic MIDI (musical instrument digital interface) digital control methods.

## HISTORY

Despite the relatively recent explosion of electronic instrument designs, the first experiments in developing the technology actually date back to near the beginning of the twentieth century. Probably the earliest such instrument was the Telharmonium built in 1906 by Thaddeus Cahill. This extremely ungainly instrument weighed in at over 200 tons and was more akin to a traditional organ console, as it did not actually generate its own sounds. Instead, it used transmitted, or broadcast, signals that travelled over long distances to enable electrically-triggered acoustic sounds. In the 1920s, two Frenchmen, Eduoard Coupleux and Joseph Givelet, invented a device similar to the modern player piano. Their machine used rolls of punched paper to trigger electrically-driven mechanisms that, in turn, controlled oscillator-generated pitches, as well as additional performance nuances such as tone and volume control. The device was called an *automatically operating musical instrument of the electric oscillation type*.

Although these machines and other such devices continued to be developed, it was not until the decade following World War I that we began to see the appearance of electronic instruments. Perhaps the most notable of this group of early post-war instruments was known as the aetherophone, or Theramine, as derived from its inventor and developer, Leon Theramin. This device used a single vacuum tube connected to a length of wire as a means of generating oscillations of various pitches. By changing the length of the wire, Theramin was able to produce a nearly infinite number of different pitches. A similar machine, the Trautonium developed by Friedrich Trautwein in 1930, utilized a neon tube as an oscillating device, although the basic underlying operating principle was similar to that of the Theramine.

The post World War II decades of the 1940s and 1950s witnessed a near explosion of new electronic instrument designs. For the first time, engineers began to work hand-in-hand with music composers contemporary to that time. It was in the late 1940s that the French government initiated a move toward state support for the basic development and implementation of such endeavors. Initially, the French government provided special funding for recording and composition studios. The earliest composers to utilize these studios created numerous compositions using the *musique concrète* methods developed by Pierre Schaeffer and Pierre Henry in 1948, whereby real sounds, such as horns and sirens, were

recorded and manipulated for use in the pieces. The first such studio was called the Radiodiffusion of Paris. In 1951, German engineers from Radio Cologne also began to collaborate on such projects. The government, working hand-in-hand with the composer Friedrich Enke, pioneered the use of electronic oscillators and began to seriously promote the infusion of such sounds into more traditional performance mediums. In 1952, Friedrich Trautwein expanded the design of his Trautonium developed some twenty years earlier. This refined instrument, now renamed the Monochord, resulted in a much greater level of control over the various sound-generating parameters. Shortly thereafter, Harold Bode generated a polyphonic version of Trautwein's machine, naming it the Melochord.

The year 1959 found the engineers at the RCA Corporation in the final stages of designing and constructing a completely oscillator-based, music-making system to be installed in the Columbia-Princeton Electronic Music Center in New York City. The machine, known as the Mark II, used a paper-tape system of operation similar to that employed by Coupleux and Givelet (see above). The synthesizer was extremely large and complex and required a significant physical facility with very precise atmospheric controls.

In the mid 1960s, Robert Moog developed the first relatively small, cost-effective synthesizer. Moog's machine represented the first real practical application of voltage-controlled oscillators for musical sound production. The new Moog synthesizer quickly developed as the instrument of choice for many contemporary musicians. Its relatively small size and portability definitely helped to establish it as the preferred machine among musicians engaged in the use of synthesized music production. Indeed, it became the catalyst for extensive use by composers whose music ran the gamut from contemporary art music to progressive rock.

The Moog was designed in separate parts, or modules, that were connected together manually with electrical cables referred to as patch cords. The use of these cords enabled users to define mechanically their desired synthesis stages, thus enabling rather precise control over resultant sounds. It was this patch-chord design of the Moog that offered an immensely flexible way for composers and performers to generate and alter a plethora of different sounds and effects very quickly and with a minimum of effort. Creating new sounds, and particularly recreating previously created ones, was easily accomplished by plugging in the proper chords into the appropriate locations on the modules. To facilitate the use of the synthesizer in real-time performance settings, Moog also incorporated a piano-style keyboard for use as a control device, thus heralding the birth of the first truly performable electronic musical instrument. A similar machine was also developed independently by Donald Buchla. This machine, however, utilized metal plates instead of a keyboard for performance input, making it much more difficult to perform on. Consequently, it was never really accepted as a viable alternative to the Moog. It was the flexibility and portability of Moog's machine that ultimately ushered in the popularity of the electronic instrument. Other companies developing early synthesizers included Electrocomp, Arp, Synthi, Roland, New England Digital, and Korg, all modelled along the basic lines of Moog's machine.

In the 1970s, Moog introduced the use of dials and switches to simplify the setting of various sounds, thus re-

placing the use of patch chords altogether. The use of the term patch became so pervasive in referring to the creation of a particular sound, however, that it is still used today to refer to particular control settings of an electronic instrument, even though no physical cords are actually employed in determining those settings. The advent of transistors further lead the way toward a developmental revolution in the design and construction of electronic instruments. Transistor technologies quickly lead to the development and application of solid-state components for music synthesis. Moog's table-size modules could now be replicated in sizes many times smaller. This development allowed for the inclusion of traditionally discrete modules into single, complete synthesizers, later to be reduced to elaborate integrated circuits and computer control.

The early 1980s also saw the application of computers and related technologies to the control and interaction of electronic instruments. Smith, Kakehashi, and Oberheim, three individuals influential in the electronic synthesizer industry, worked together with such industry giants as Yamaha, Korg, and Kawai, to create a standardized protocol for the simple and consistent interchange of control information between electronic devices. In 1983, they published the *MIDI 1.0 Detailed Specifications*, thus formally documenting their efforts. Currently, these software specifications are regulated and distributed by the International MIDI Association (IMA), while hardware and manufacturing specifications are regulated by the MIDI Manufacturing Association (MMA). MIDI adaptation has led to a true revolution in the use and control of electronic instruments, as the MIDI specifications were quickly adopted industry wide. MIDI technology now represents the standard by which all digital instruments communicate between each other and controlling devices such as computers and analog-to-digital processors.

## ANALOG OSCILLATORS

Analog synthesis methods were the primary underlying technologies utilized for the generation of the synthetic sounds germane to most electronic instruments prior to the 1990s.

Analog methods of synthesis relied extensively on the use of analog oscillators. Essentially, an analog oscillator is an electrical circuit that alternates, or vibrates, according to a fixed (regular) frequency. Such a frequency is based on the rate of alternation between voltage peaks. In addition, oscillators output vibrations with a given amplitude, or strength, determined by the amount of voltage applied to the oscillating current. The resulting electrical output signal is then fed back into the original circuit in order to reinforce the original oscillation. When the total energy gain of the circuit finally exceeds the total energy loss, thus pushing the signal to the point of feedback, the circuit becomes self-generating. In other words, it becomes an oscillator. If the oscillated signal is within the audible frequency range, it is termed an audio oscillator (or sound oscillator), and the sound it creates is called an audio signal.

A wave form represents the actual shape or contour created by the alternations of an oscillated signal. Any number of various shapes can be applied to an oscillating current; however, there are only four wave forms used pervasively by analog electronic instruments. The terms used to name these

waves are derived from the shapes they create when the oscillating signals are plotted on a two-dimensional grid. Such a plot represents the voltage level on the vertical axis and temporal duration of the signal on the horizontal axis. These four common wave forms are defined as the (1) sine wave, (2) square wave, (3) sawtooth wave, and (4) triangular wave. Representative examples are shown in Fig. 1.

The sine is the most basic of the various wave forms. By adding additional overtone frequencies to the sine wave (e.g., partials of the 2nd, 3rd, 4th order), the other forms can easily be created. A random mixture of nonovertone frequencies creates a phenomenon known as a random wave. Through the various combinations of mixing and blending electronic oscillator outputs, wave forms and tones generated by these devices can create an incredible number of various colors and blends of sounds. It is these oscillator-produced sounds that, together with the myriad of combinations and variations derivable from manipulating and combining them, form the foundation of all predigital electronic music.

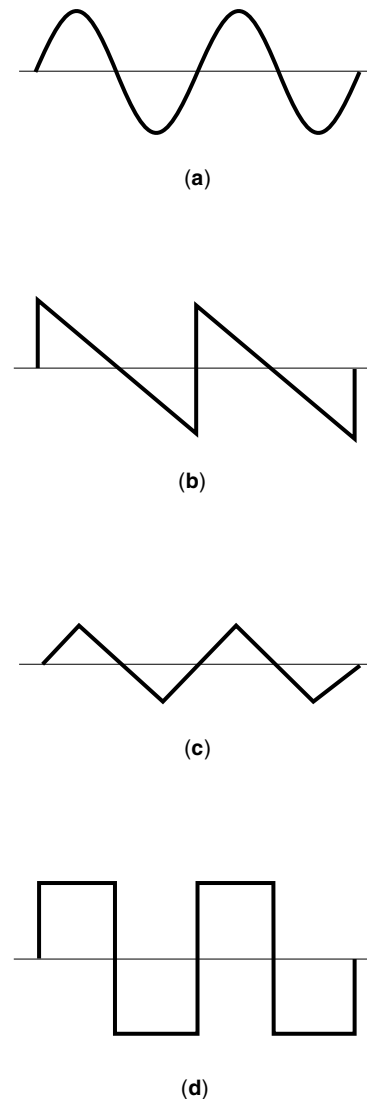

**Figure 1.** Wave forms: (a) sine wave, (b) sawtooth wave, (c) triangular wave, (d) square wave.

## ANALOG SYNTHESIZERS

Electronic instruments that are solely reliant upon oscillator-generated production of electronic sounds are called analog synthesizers. In fact, a primary design feature of these instruments is to generate, alter, and control the musical sound without employing any mechanical devices, such as the vibrating bodies of instrument strings or percussion diaphragms. For example, synthesizers typically use discrete amounts of electrical voltage to control the pitch, volume, timbre, etc. of the sounds they produce. To facilitate the use of such an instrument by musicians, modern synthesizers are generally controlled with a piano-style keyboard where each key controls a particular pitch or function by controlling the amount of voltage applied to the oscillating circuitry. Such an operation, in turn, might trigger one or several voltage-controlled oscillators (often referred to as VCOs) to produce an alternating current at a selected frequency. These oscillator triggers are typically referred to as gates. Standard engineering design calls for one volt of increase to represent a one-octave jump in the pitch of a note; thus,  $1/12$ th V steps are used to create the chromatic division of the musical octave (see Fig. 2).

Synthesizers often contain more than one oscillator, both for the purpose of creating multiple sounds and for combining their signals together to create more complex individual sounds. Synthesizers capable of producing two or more simultaneous sounds are referred to as being polyphonic (or sometimes multitimbral or polytimbral) as opposed to monophonic (or monotimbral) machines that are capable of only playing a single pitch at any one time.

Most music-generating oscillators function within the 20 Hz to 20,000 Hz range of sounds deemed audible by human ears. Certain subaudio oscillators (0.5 Hz to 30 Hz), however, can be used to modify the sound of these standard audio oscillators in order to create a wide variety of musical and special effects. These inaudible oscillators are referred to as low-frequency oscillators, or LFOs. When used to change or modulate a main oscillator, the process results in various forms of vibrato, or frequency modulation. In other words, a wavering effect is produced by repeatedly alternating between slightly intensifying and diminishing the amplitude of a fixed pitch. A similar aural effect is achieved by alternately varying the frequency of a given pitch up or down slightly. This process is referred to as tremolo, or amplitude modulation.

Pitchless, random noise generators create white noise or pink noise. These sounds, for example, can be used to create various other pitchless effects, such as imitating the resonating ring of a brass cymbal or the percussive rasp of a snare drum. Voltage-controlled filters, or VCFs, can also be employed to block out various frequencies while allowing others to pass through unaltered. Synthesis through the use of such filters is referred to as subtractive synthesis.

Ascending major scale

Pitches	=	C4	D4	E4	F4	G4	A4	B4	C5
Voltages	=	1	$1\frac{1}{2}$	$1\frac{1}{2}$	$1\frac{1}{2}$	$1\frac{1}{2}$	$1\frac{1}{2}$	$1\frac{1}{2}$	2

Figure 2. 8va-division diagram.

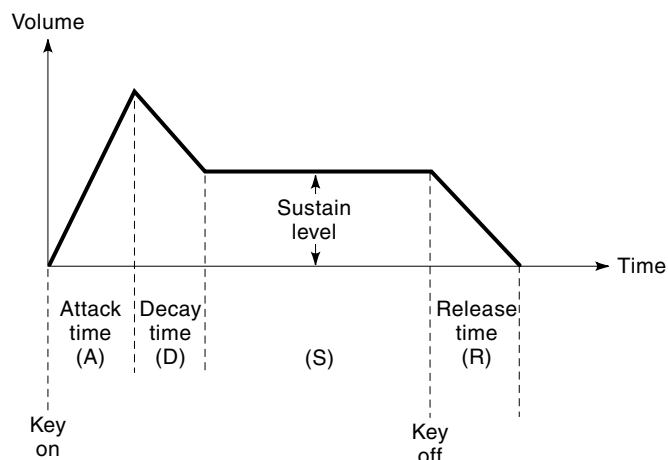

Figure 3. ADSR diagram.

Electronic music synthesizers commonly use envelope generators to control the temporal, or time-based, quality of an oscillated sound. Specifically, envelope generators control how a sound is initiated (attack), how it reacts immediately after the initial attack (decay), how it lingers as it decays (sustain), and how the sound ultimately ends (release). Envelope generators are also referred to as voltage-controlled amplifiers, or VCAs. These four basic parameters are shown graphically in Fig. 3.

To enable a greater level of control over parts of the sound envelope, some synthesizer keyboard controllers are designed to be velocity sensitive; in other words, they can react to the force (speed) with which a key is depressed. Other controllers may also be designed to be pressure sensitive. Such a controller is able to respond to the pressure (after touch) exerted on a key after it has reached the furthest extent of its physical travel.

Some nonkeyboard controllers rely upon other means of generating electrical signals for controlling oscillation. For example, voltages generated by an electric guitar pickup (transducers) can be employed to trigger oscillators at the same frequency as the string being plucked. Some even more unusual controllers rely upon mechanical means for controlling oscillation, such as the use of drum membranes (pads or heads) as triggering devices or wind-controlled pressure on an imitation saxophone reed.

Many synthesizers have both built-in computer circuits to enable elaborate control over all of the various controls and interactions of the oscillator functions and the ability to store and retrieve such data for future use. Many electronic synthesizers also incorporate internal timing clocks that allow for the storage and retrieval, not only of recorded (sequenced) pitches but also for all the timing information needed to retrigger the various oscillators and control functions at the appropriate times, thus allowing the instrument to store and reproduce real-time performances, much like a tape recorder can do. Figure 4 shows the basic structural design of a typical electronic analog synthesizer.

## DIGITAL SYNTHESIS

Unlike its analog predecessors, digital synthesizers use microprocessors to generate and control most synthesis func-

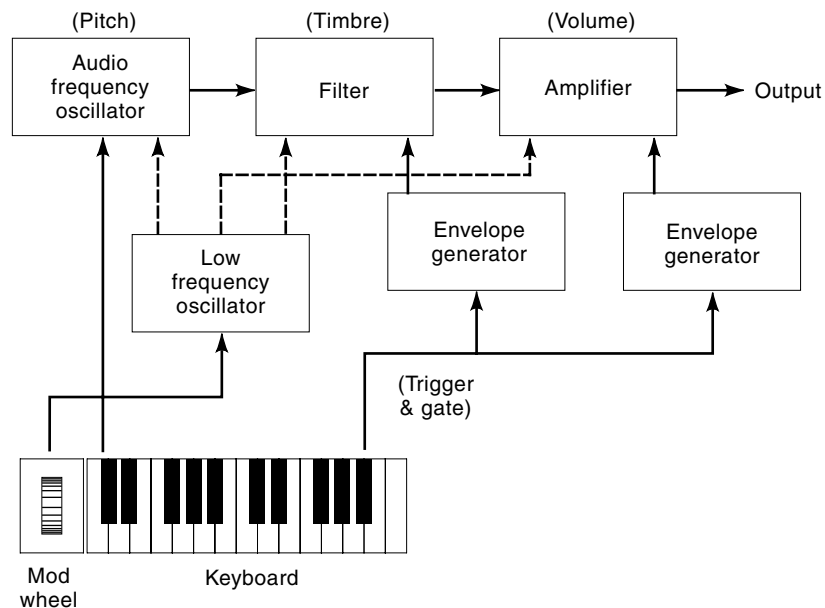

Figure 4. Synthesizer structure diagram.

tions. Instead of relying upon analog oscillators to generate musical sounds, digital synthesizers use numeric information as abstract representations of a wave form (wave table). If we were to take the numbers from such a table and reconvert them into voltages, we would actually derive a wave that is varied from the original, as the digital data cannot recreate the infinite voltage variations of a truly analog wave form. Obviously, the greater the number of samples collected (sampling rate), the closer the recreated wave will be to the original from which the data were derived. And, unlike the simple sine waves produced by individual oscillators, digitally constructed wave forms are not restricted to such basic forms. Essentially, any complex wave can be created with the appropriate sequence of numbers. Figure 5 shows the type of wave re-created from such a wave table.

To create digitally represented sounds with an electronic instrument, data from a wave table is converted into varying voltages through an electronic digital-to-analog converter, or DAC. In the case of most synthesizers, DACs work with voltages ranging from +5 V to +12 V on one extreme and -5 V to -12 V on the other. Depending on the resolution of the electronic circuitry, each number from the wave table will convert to a percentage of the distance between the outer ranges of the DAC. For example, if the numeric data within

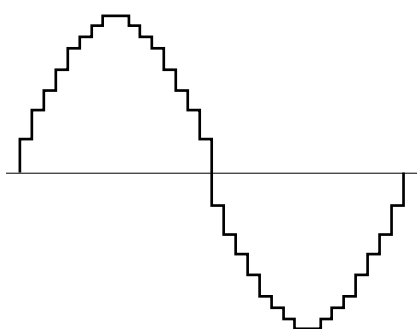

Figure 5. Digital wave form.

a wave table ranges from 1 to 256, then the number 1 would translate to a -5 V, 256 to +5 V and 128 to 0 V, so on.

The speed at which the numbers are sent to the DAC ultimately controls the frequency of the generated pitch. If numbers are sent to the converter at a speed twice that at which the original numbers were derived, then the resultant pitch will be twice the original frequency as well. As pitches get higher, the speed at which the numbers need to be sent to the DAC can outpace the capacity of the circuitry to process them. As a result, some numbers will be thrown away, causing the resultant pitch to be represented by fewer sampled values. These pitches will be less able to represent the nuances of the original, resulting in a potential loss of quality.

Regardless of how many divisions of a waveform are used when creating a wave table, the resultant wave will always be represented by a series of jagged voltage steps and must be smoothed out with the use of various circuitries. These filtering circuits are designed to convert a fixed voltage into a varying set of voltages progressing up or down from the previously specified voltage, thus coming much closer to an analog wave form. The results of a typical filtering process are shown in Fig. 6.

## DIGITAL SYNTHESIZERS

While it is relatively easy to create a basic wave form through the use of wave tables and DAC conversion, creating complex musical sounds and effects still requires the use of extensive mixing and blending circuitries and the application formulaic methods of manipulation. It is in this respect that digital synthesizers excel. Regardless of whether the basic waves are generated through DAC circuits or oscillators, digital synthesizers utilize a wealth of electronic methods to create more complex forms. Mixing circuits and formulas designed to generate complex wave forms are referred to as algorithms.

Several of the most common types of algorithms include: (1) additive synthesis, (2) frequency modulation (FM), (3) wave shaping, and (4) linear arithmetic techniques.

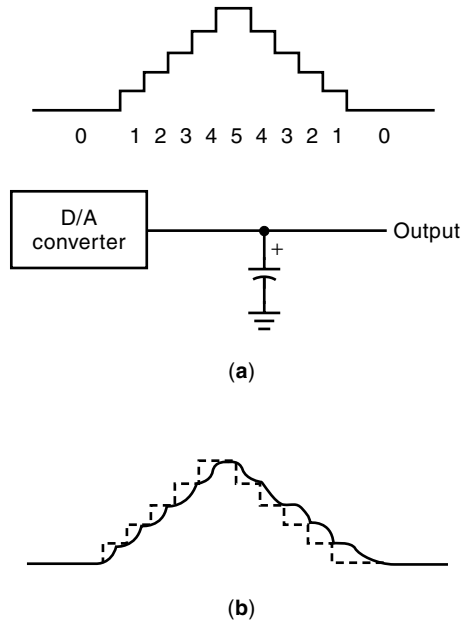

Figure 6. Jagged-to-smooth wave form: (a) original, (b) filtered.

**Additive (Harmonic) Synthesis**

This method is used to create multiple timbres by combining (adding) multiple simple or complex waves at varying pitches and volumes. This method is also known as Fourier synthesis after the French physicist who discovered that complex waves can be described as combinations of simple waves. This process can be implemented by combining the output of numerous oscillated signals together, or by summing the difference of the data values from several wave tables or the same wave table sampled at different rates. An example of additive synthesis is shown in Fig. 7.

**Frequency Modulation**

This method combines a modulating wave (the modulator) with an audible wave of a desired frequency (the carrier) to effect various timbres without varying the pitch of the carrier. Utilizing a subaudio modulator reproduces the carrier frequency exhibiting a warbling (tremolo) effect. If the modulator is in the audible range, however, any number of complex sounds can result from the combination. The original commercial example of the use of this method was the Yamaha

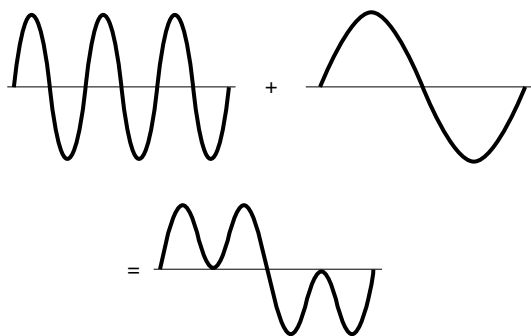

Figure 7. Diagram of additive synthesis.

DX-7, which was a significant success with over 100,000 units sold in the first three years alone. An example is shown in Fig. 8.

**Wave Shaping (Nonlinear Distortion)**

This method distorts, or bends, a simple wave form into a complex one, thus enabling a significant number of timbres to be created from one simple wave.

**Linear Arithmetic Techniques**

In this method two prestored (sampled or generated) musical partials (overtones) are combined into a single tone. Any two tones can then be combined into a more complex patch, etc. Various effects can then be applied to a patch. The best commercial example of the use of this form is the Roland D-50 synthesizer.

The choice of analog vs. digital models of synthesis for electronic instruments began as a historical argument; however, it is not simply an issue of which model is better, as they both have inherent strengths and weaknesses. Ultimately, the intermingling of both analog and digital methods to obtain a variety of effects and sounds offers users the best of both worlds. With more advanced electronic synthesizers now combining most of the elements of a computer, complete with disk drive for external storage and transfer of data, the interactive and manipulative possibilities become even greater.

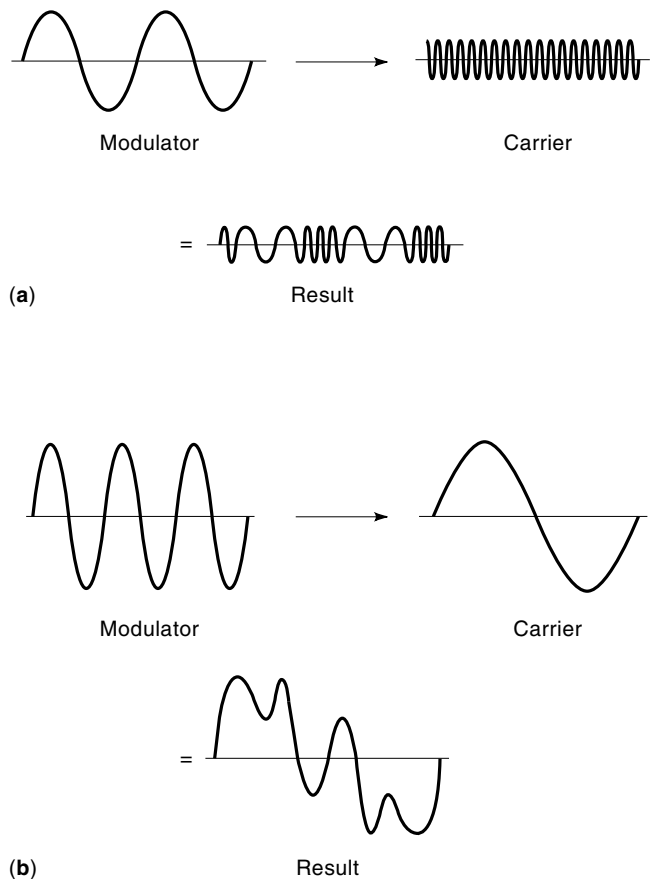

Figure 8. Diagram of FM synthesis: (a) with subaudio modulator, (b) with audio modulator.

Despite all the inherent strengths of such machines, they all share a common weakness, nonetheless. Many analog sound waves created by natural instruments such as the violin, are so complex as to be virtually impossible to closely imitate through any of the methods already examined. The technology of digital sampling, however, is the first technological process powerful enough to circumvent most of the problems inherent in generating such complex waves electronically.

### SAMPLING (DIGITAL)

The process known as digital sampling is designed to enable the sounds of real instruments to be re-created as closely to the original as possible within a digital environment. Rather than utilizing oscillators or abstract wave tables that cannot begin to capture all the nuances of complex real-world sounds, sampling accomplishes this goal by recording a desired analog sound and then translating that sound into a wave-table format usable by a digital synthesizer. Such numeric data is typically derived by taking regularly timed voltage readings (samples) at different points along an analog wave. The resultant data can then be assembled into a list, or wave table, where all the data points collected during one entire wave cycle are stored. Once a sample sound is recorded and translated, it can then be manipulated in any number of ways to create variants of the original recorded sound. Examples of such manipulations include speeding up or slowing down the playback, reversing the sample, segmenting it, looping it, filtering in any number of ways, etc. Unlike true synthesis, however, these effects are all added to a recreation of an existing analog sound rather than being created through the layering of various abstract digital sound sources. Quality samples also need the Attack, Decay, Sustain, and Release (ADSR) information of the source sound in order to attempt an accurate re-creation. To obtain such information, samples need to contain more than just the information obtained from one wave form. Longer samples, therefore, are ultimately better able to re-create more realistic sounds than shorter ones. In fact, some digital samples can last for many seconds and require millions of pieces of digital data to represent them. Obviously, demands such as these require significant computational and storage resources. One method for scaling down these requirements is to sample shorter segments of a sound and loop them to create a sense of continuous flow. Sounds that change constantly (for example, the human voice), however, are not very suitable for such kinds of sampling. In addition, samples done at one pitch and slowed down or sped up to create different ones, often lack the changes in timbre generally reflected in different pitches from one instrument.

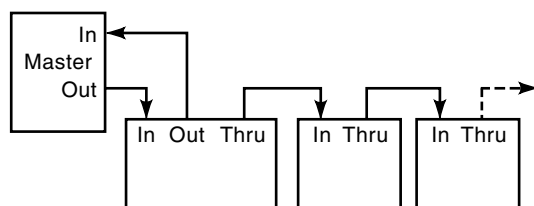

Figure 9. Schematic of a typical MIDI setup.

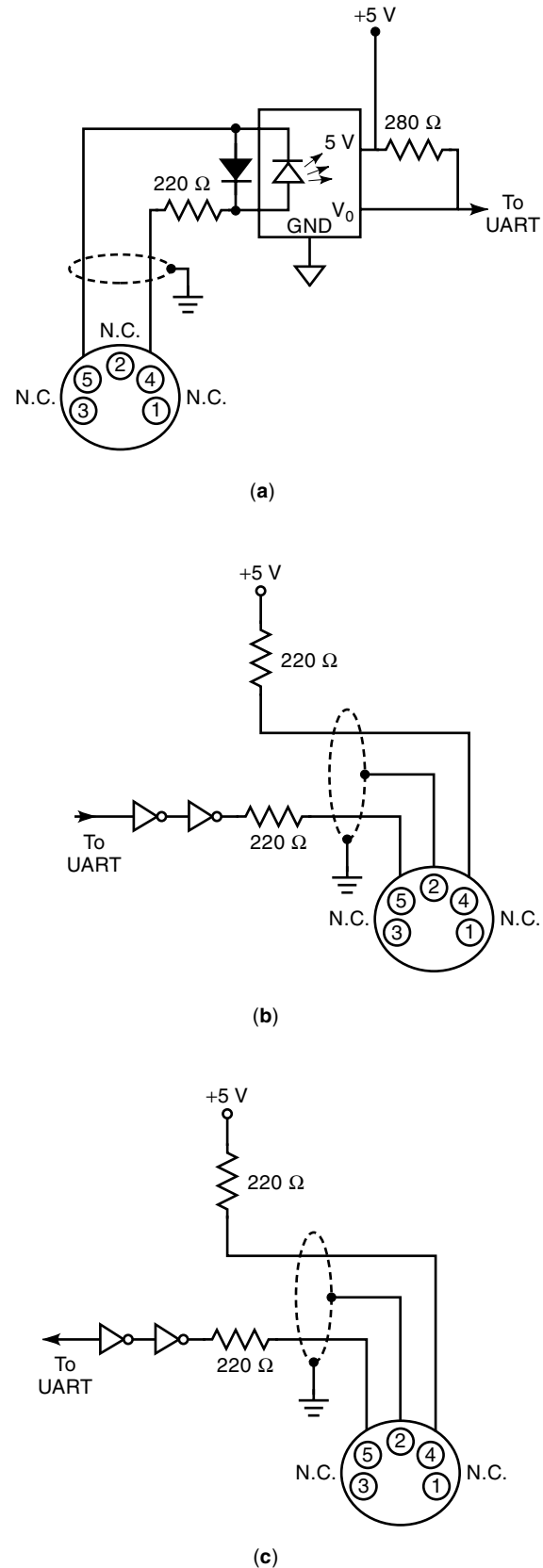

Figure 10. (a) The MIDI IN circuit, (b) the MIDI OUT circuit, (c) the MIDI THRU circuit.

**MIDI**

As synthesizers became more complex and specialized, the need to develop methods of communication between instruments became more acute. MIDI was developed as a means for enabling electronic instruments and other devices to communicate with one another. It is important to note that MIDI instruments do not transmit actual data, such as wave tables, ADSR values, and so on. MIDI devices simply transmit control codes that instruct the connected instruments to perform various operations. For example, a MIDI command can be sent to a synthesizer in order to have it begin playing the note “middle-C.” The synthesizer must have the capabilities to generate that sound internally without any assistance from the communicating machine. The MIDI data simply informs the synthesizer about such things as what pitch should be played, in the same manner as depressing a key on the keyboard would.

To enable a large number of electronic devices to be connected together, the MIDI specifications call for data to be

transmitted over any one of 16 channels. Individual instruments or devices can be set to transmit and/or respond to any one of these channels, thus enabling up to sixteen different devices to talk with one another. MIDI instruments can also operate in several different global modes. In OMNI mode, from omniscient *for everywhere*, an instrument receives information from every channel simultaneously. When turned off, it receives only information addressed to the one channel specified for that machine. In POLY mode (derived from the term polyphonic), a synthesizer can play more than one note at a time (up to the maximum capacity of the machine—typically 16 to 32). On the other hand, MONO mode (from monophonic) restricts a synthesizer to playing only one note at a time. If one note is sounding when another is played, the first note is immediately truncated.

**MIDI (hardware)**

Transmission of MIDI data between any two MIDI-equipped devices is accomplished through a pair of serial interfaces.

Baud rate: 31,250 BITS per second (c 3,900 BYTES per sec.)

Status bytes: 128-255 (80-FF; 1xxxxxxx)

Data bytes: 0-127 (00-7F; 0xxxxxxx)

MIDI messages (128-239; 80h-EFh):

## • Channel voice messages:

Note off	128-143 (80h-8Fh)	(1000nnnn 0kkkkkkk 0vvvvvvv) n = channel, k = pitch, v = velocity
Note on	144-159 (90h-9Fh)	(1001nnnn 0kkkkkkk 0vvvvvvv)
Poly key pressure	160-175 (A0h-AFh)	(1010nnnn 0kkkkkkk 0ppppppp) n = channel, k = pitch, p = pressure
Control changes	176-190 (B0h-BFh)	(1011nnnn 0ccccccc 0vvvvvvv) n = channel, c = control, v = value; Channel Mode Msg = c122-c126;
Program change	191-206 (C0h-CFh)	(1100nnnn 0vvvvvvv) n = channel, v = synth patch #
Channel pressure	207-223 (C0h-DFh)	(1101nnnn 0ppppppp) n = channel, p = pressure
Pitch bend	224-239 (E0h-EFh)	(1110nnnn 0bbbbbbb 0BBBBBBB) n = channel, b = LSB, B = MSB

System messages (240-255; F0h-FFh):

## • System common messages:

System exclusive	240 (F0h)	(11110000, 0iiiiiii, 0xxxxxxx ...) i = index #, x = anything!
Channel mode msg	241-246 (F1h-F7h)	(11110nnn, <variable>) n = message type
End of excl. (EOX)	247 (F7h)	(11110111)

## • System real-time messages:

Timing clock	248 (F8h)	(11111000)
Start	250 (FAh)	(11111010)
Continue	251 (FBh)	(11111011)
Stop	252 (FCh)	(11111100)
Active sensing	254 (FEh)	(11111110)
System reset	255 (FFh)	(11111111)

**Figure 11.** Table of MIDI control data.



Communication between two MIDI interfaces occurs at a transmission (baud) rate of 31.25 kbit/s through a 5-pin DIN connector. Since each connector transmits data in only one direction, twin cables are required for two-way transmissions. Most MIDI interfaces contain three DIN connectors labeled MIDI OUT, MIDI IN, and MIDI THRU. These connections allow, respectively, for sending data out to another machine, receiving data in from another machine, or passing incoming information unaffected through the receiving synthesizer to another synthesizer. A schematic of a typical MIDI setup is shown in Fig. 9. Figures 10(a–c) shows basic schematic diagrams for a simple MIDI interface.

### MIDI (data)

MIDI data is transmitted as a serial stream of digital binary codes, consisting of individual or multiple eight-bit messages (bytes) formatted to fit the requirements of the MIDI specifications. In addition, recall that MIDI information can be transmitted on any one of 16 channels.

The MIDI data specifications actually call for the representation of numerous parameters of synthesizer operation. A status byte is represented by 128 numbers, spread across the range of 128 to 255 (the upper-half of an eight-bit byte), and tells the receiving unit that some action is required. Status information can be addressed to each of the sixteen channels independently. To accomplish this, the status message actually utilizes the upper four bits of the byte, while the lower four bits identify the channel being addressed. In reality, this method allows for eight different status codes enabled across 16 channels ( $8 * 16 = 128$ ). For some status groups, such as Note On and Note Off, the same command is duplicated for each of the sixteen channels. Thus, 144 represents the status code for a Note On in channel one, 145 represents a Note On for channel 2, and so on. The last group of status bytes (240–255) are reserved for functions that are not channel specific, thus enabling an additional 15 codes.

Most status bytes are followed by one or two additional data bytes functioning as modifiers for the preceding status byte. Data bytes total 128 and span the range from 0 to 127 (the lower half of an eight-bit byte). For example, the Note On code for channel one (144) is followed by two data bytes. The first specifies which note is to be turned on, and the second specifies the velocity with which the note is to be played. Figure 11 shows a partial MIDI implementation chart, documenting the various status bytes and their respective data formats.

### CONCLUSIONS

The creation and implementation of digital methods of synthesis have served partially to stabilize the development of electronic instruments. Obviously, constantly improving electronics are enabling more powerful and feature-laden synthesizers to appear; however, the basic methods of digital synthesis remain fundamentally unchanged.

The same cannot be said, however, for the MIDI standards. The original implementation of these standards has already undergone several significant revisions since version 1.0, mostly in efforts to stretch the ability of the standard, so that it can deal with control specifications not implemented originally. For example, the development and widespread use of the *Standard MIDI Format* specifications has led to a greater level of standardization between different manufacturers of electronic instruments. This specification calls for a number of synthesizer sounds (voices) to be standardized, so that MIDI files transferred from one machine to another will most likely trigger the production of similar sounds. With the continued development of more enhanced electronic instruments, we can continue to expect that the MIDI specifications will undergo additional significant revisions.

### BIBLIOGRAPHY

- H. A. Deutsch, *Synthesis: An Introduction to the History, Theory and Practice of Electronic Music*, Rev. ed., Sherman Oaks, CA: Alfred Publishing, 1985.
- J. E. Eiche, *What's a Synthesizer?* Milwaukee, WI: Hal Leonard Books, 1987.
- D. T. Horn, *Music Synthesizers: A Manual of Design and Construction*, Blue Ridge Summit, PA: Tab Books, 1983.
- D. T. Horn, *Digital Electronic Music Synthesizers*, Blue Ridge Summit, PA: Tab Books, 1988.
- S. Junglieb, *General MIDI*, Madison, WI: A-R Editions, 1995.
- L. Kettelkamp, *Electronic Musical Instruments*, New York: William Morrow, 1984.
- H. P. Newquist, *Music & Technology*, New York, Billboard Publications, 1989.
- J. Pressing, *Synthesizer Performance and Real-Time Techniques*, Madison, WI: AR-Editions, 1992.
- J. Rothstein, *MIDI: A Comprehensive Introduction*, Madison, WI: AR-Editions, 1992.
- A. Strange, *Electronic Music: Systems, Techniques, and Control*, Dubuque, IA: Wm. C. Brown, 1983.
- J. Strawn, *Digital Audio Signal Processing: An Anthology*, Los Altos, CA: Kaufmann, 1985.
- M. Vail, *Keyboard Presents Vintage Synthesizers: Groundbreaking Instruments and Pioneering Designers of Electronic Music Synthesizers*, San Francisco: GPI Books, 1993.
- D. B. Williams and P. R. Webster, *Experiencing Music Technology: Software, Data, and Hardware*, New York: Schirmer Books, 1996.

JOHN WM. SCHAFFER  
University of Wisconsin School of  
Music

**MUSIC, COMPUTER.** See MULTIMEDIA AUDIO.

**MU-SYNTHESIS CONTROL.** See ROBUST CONTROL.

**MUTUAL INDUCTANCE.** See INDUCTANCE MEASUREMENT.

**MYOELECTRIC CONTROL.** See ARTIFICIAL LIMBS.

**MYOELECTRIC PROSTHESIS.** See ELECTROMYOGRAPHY.

**MYOELECTRIC SIGNALS.** See ELECTROMYOGRAPHY.