

## TRANSMITTERS FOR DIGITAL TELEVISION

The television industry in the United States began the search to improve the quality of television images and sound as early as the 1970s, and the Federal Communication Commission sought more spectrum in the 1990s. These two paths collided and ultimately led to digital television or DTV. The desire was to put improved television (TV) in the same bands allocated for existing TV channels. These frequencies are low VHF (55 MHz to 88 MHz) channels 2–6, high VHF (176 MHz to 225 MHz) channels 7–13, and UHF (476 MHz to 860 MHz) channels 14–69. The intent is to place another complete set of TV stations on air that are compatible with the existing NTSC (National Television System Committee). This requires that channels be allocated adjacently and that they not interfere with each other. As we shall see, this adjacent operation tightly restricts digital TV transmitters.

The design for practical digital television transmitters began in the 1980s. During this decade the television industry began to consider the use of over-the-air transmission of TV of such quality and function that new RF power schemes evolved. The goal for producing significant digital TV signal power is to

- reproduce the idealized signal suitable for demodulation (controllable linearity),
- provide the highest efficiency (power out versus power used), and
- deliver a signal that is reliable, practical, and thus useful.

Over-the-air terrestrial digital TV requires high power, typically a few kilowatts to hundreds of kilowatts. Compared with cable, wireless cable, or satellites, this is substantially different and deserves special attention. Whether the digital TV transmitter is used for the system in the United States or another digital system, as will be discussed, the requirements are similar.

### DIGITAL TV MODULATION

It is necessary to consider the possibility of direct modulation of a single RF carrier with the modulation needed for digital TV as well as amplification of a modulated digital TV signal. This possibility would be simplified if the TV modulation signal was a single carrier and symmetric rather than a full double sideband RF signal. However, the signals used for over-the-air TV broadcast is a combination signal: AM and PM, or vector modulation.

Two modulation systems have been approved for use in terrestrial broadcast:

- 8 level vestigial sideband (8VSB), often referred to as the Advanced Television System Committee (ATSC) standard.
- Orthogonal Frequency Division Multiplex (OFDM), which is also referred to as Digital Video Broadcasting—Terrestrial (DVB-T).

Many other digital modulation techniques are used in television services, and many types of digital modulation possibili-

ties exist. Television delivery such as Cable TV (CATV), Satellite Direct to Home, Wireless Cable, or the PC (personal computer) telephone modem may use a scheme different to optimize delivery versus transmission path characteristics and digital payload.

It is significant to note that digital modulation is generally thought of in terms of AM. This is a result of the fact that the signal does “go to zero” at some time. However, it is similar to PM/FM in that the signal has no low-rate time-varying component. Comparisons of terrestrial analog TV and digital TV at RF are enlightening:

Analog TV at RF	Digital TV at RF
Peak to average varies	Peak to average constant
RF never goes to zero	RF goes to zero
Power changes with picture content	Power constant for any picture content
In-channel noise corrupts picture	Noise below threshold does not corrupt

These differences require approaches to digital power amplifiers that may be compared to conventional analog (NTSC/PAL/SECAM) RF amplifiers. As we shall see, the requirements for digital transmitters are different enough that specific considerations must be made.

### DIRECT RF MODULATION

Any system that can be devised for direct modulation at higher powers instead of linear amplification may well exhibit improved efficiency. This is true of many schemes such as AM transmitters. For example, full double sideband AM can be created by using efficient RF amplifiers in the final and then proportionally modulating the applied power supply or turning on/off stages. Transmitters are known to exhibit up to 85% overall efficiency in this mode.

Digital TV such as DTV and DVB-T signals are not symmetrical and have both AM and PM components. Thus to directly generate the modulated RF signal requires both AM and PM techniques. This requirement leads to a general method termed Envelop Elimination and Restoration Technique (EERT or also ERT). ERT is, however, limited in effectiveness due to the need to cancel signals in the final power stages.

### Amplification of Digitally Modulated Signals

The most common way to increase the power of an RF signal is simple amplification. This is generally straightforward for signals of a few watts but becomes increasingly more complicated as the power extends above several kilowatts. At issue is the amplitude and phase linearity of the amplifying device.

### Modulated Single Carrier Systems: QPSK, QAM, and 8VSB

The ATSC selected system uses a modified Quadrature Amplitude Modulated (QAM) system called 8VSB. QAM (sometimes abbreviated QUAM) is generated by amplitude-modulating an RF carrier ( $\sin wt$ ) and summing it the same RF carrier  $90^\circ$  phase shifted [ $\sin(wt + 90)$ ] that is modulated differently. By modulating these two carriers with multilevel digital signals, multilevel QAM is generated.

To create 8VSB, a 64 QAM signal can be generated and then filtered with a Surface Acoustic Wave (SAW) to eliminate the lower sideband.

#### Modulated Multicarrier Systems: DVB-T

To meet the needs of the European market, another digital modulation method is used. European needs are different from those in the United States: multiple languages, more mountainous terrain, denser population, and single program coverage nationally, to name a few. Today's European analog systems (PAL and SECAM) use lower-powered transmitters than in the United States. The system chosen for Europe, DVB-T or OFDM, uses many carriers (thousands), each digitally modulated and contained in a single TV channel (8 MHz in Europe versus 6 MHz in the United States). The carriers are each modulated with a portion of the digital information and thus spread the digital data across the 8 MHz spectrum. Spreading data across the spectrum improves the likelihood of lessened interference resulting from multipath propagation.

#### POWER AMPLIFIERS FOR TV

Power amplifiers are the last active element in the RF path before the antenna system. The power amplifier final amplifying stage is the most critical. This final stage determines the critical characteristics of the broadcast signal. Power amplifiers are generally nonlinear and band limiting, thus creating distortions of the input RF signal. Power amplifier nonlinearity creates both in-band and out-of-band intermodulation products within the amplifier. In-band products are important because the received bit error rate (BER) is affected and decoding errors will be produced if the intermodulation products (IPs) are too high. Out-of-band nonlinearity (spectrum shoulders) must also be minimized to prevent interference with adjacent analog and digital services. In most transmitters correction signals for amplitude and phase nonlinearities are applied to the input signal of the digital amplifier correcting both the in-band and out-of-band intermodulation distortions at the same time. Therefore, reductions in both the in-band and out-of-band IPs coincide. The only exception to this is when frequency response or group delay errors are present in the amplifier.

#### VACUUM TUBE POWER DEVICES

Tubes have a unique place in high-frequency amplification; with a single device, they can amplify a signal to tens of kilowatts over a band from a few hundred megahertz to several gigahertz. Gridded tubes such as triodes, tetrodes, or pentodes modulate the electron beam with an applied RF voltage to the grid. Other tubes such as klystrons use an applied RF voltage to bunch electrons generated from a gun, and these bunched electrons drift through additional cavities, creating additional bunching until reaching a final cavity that extracts energy from the formed beam.

Tube amplifiers usually are limited to 1 to 5% bandwidth. This is determined by the number of resonant circuits (usually cavities) and their loading ( $Q$ ). This limited bandwidth is helpful to reduce IPs in adjacent channels but also causes group delay distortions at the band edges.

Other varieties of vacuum devices use a grid, a drift region, and an output cavity to form a tube called the klystrode or Inductive Output Tube (IOT). The IOT (Fig. 1) has found favor with digital TV by providing peak powers in excess of 100 kW at a gain of over 20 dB with good linearity.

#### SOLID-STATE POWER DEVICES

The use of solid-state devices for amplifiers has an obvious attraction but comes with some limitations. Growth of solid-state devices has led to improvements and reduction in vacuum devices usage. However, concentrated power (volts and amperes) and power density of RF transistors have limited the usage of transistors to combined configurations (Fig. 2). The RF transistors are frequently multicelled and multichip devices in a single package to reach a typical of 150 W peak power.

#### Bipolar Transistors

Bipolar transistors are minority carrier devices and as such exhibit several distinguishing characteristics. Bipolar transistors have moderate gain and reasonable linearity but suffer from thermal runaway.

**Field Effect Transistors.** Generally, Field Effect Transistors (FETs) are majority carrier devices and can be characterized by properties inherent with this class of devices. FETs have higher gain and improved linearity and are tolerant of poor load VSWR without catastrophe.



Figure 1. Inductive Output Tube.

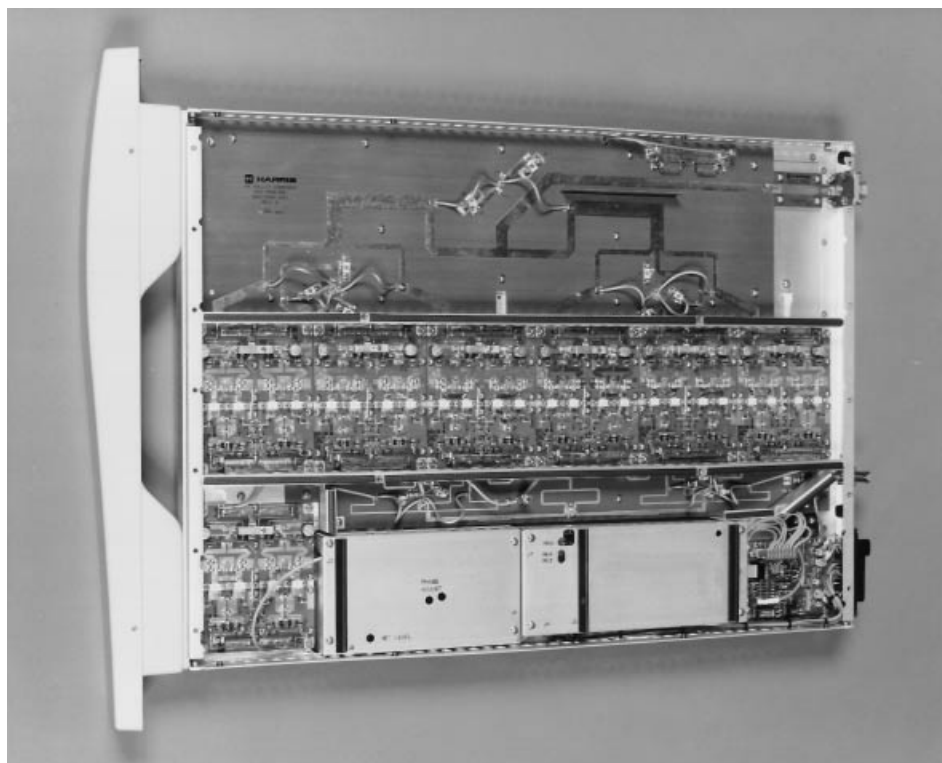

**Figure 2.** RF amplifier module.

### Other Devices

Clearly, the FET and bipolar transistors are the most widely used semiconductor devices for power amplification. Other semiconductor technologies used for power generation include: MOSFETs, LDMOS FETs, HEMPT, and GaAs.

### The Solid-State Amplifier

Transistors have one fundamental limit: they don't come with kilowatt power ratings at terrestrially delivered TV frequencies. Kilowatts (sometimes hundreds of kilowatts) of RF power are necessary for digital TV transmitters. To cover a substantial area with an antenna at a reasonable height, several kilowatts of power may be employed. A typical analog (NTSC) station has a coverage circle with radius of typically 55 mi. To duplicate this coverage with digital transmissions may take tens of kilowatts of RF power radiated from an antenna placed 1000 ft or more in the air. Transistors cannot do this with one transistor in the final PA as can be done with a vacuum device.

A single large transistor can typically produce 150 W of peak power. This means that many transistors must be combined to generate a multi-kilowatt RF signal.

### Amplifier Class of Operation

To amplify a signal with least distortion, current conduction over the 360° RF cycle (Class A) is used. Class A operation is lowest in efficiency (same power supply draw regardless of amplifier power output) and thus preferred in lower-power stages where efficiency and dissipation are not of great concern. Class A may be either a small or large signal amplifier,

depending on the scale of the design. Efficiency is limited to a theoretical maximum of 50% using Class A. Generally this is optimistic, and efficiencies of 10% to 25% are far more typical.

Class B operation (180° conduction) is ideally a linear mode of operation, but practically it is not used at high frequencies because of saturation and crossover distortions. Even with its more efficient operation, Class B finds little use because of these limitations. Of more interest and practical use is Class AB. Class AB biases the device (transistor or vacuum tube) with some idle current without RF drive and thus minimizes crossover distortions, but it retains the efficiency of Class B at higher output power. Efficiency is limited to 78% for the Class B amplifier. The Class AB mode efficiency depends on bias conditions and thus can be bracketed somewhere between the Class A and Class B efficiencies.

Class C (less than 180° conduction) and Class D (switching or saturation mode) operation exhibit higher efficiencies but exhibit no linear amplification properties. Useful for FM or power supply modulated applications, Class C amplifiers are rarely considered. Efficiency can theoretically approach 100% with Class C or D. This efficiency is shown in Table 2.

### Push-Pull Pairs

RF power amplification frequently employs the use of transistors in a push-pull configuration (Fig. 3). In a push-pull configuration, two parallel-driven transistors conduct on alternate halves of the RF cycle and then are summed. This approach simplifies the transistor combining, bias, and required circuit area.

**Table 1. DTV Transmitter Comparisons**

	IOT (UHF)	FET (UHF)	FET (VHF)
Average DTV power	25 kW	5.5 kW	5.0 kW
Main supply (V)	37 kV	32 VDC	50 VDC
Main supply (I)	1.9 A	560 A	490 A
Signal to noise (S/N)	25 dB	25 kB	26 dB
Error vector magnitude (EVM)	5%	5%	4%
Power consumption	70.3 kW at 25 kW	25 kW at 5.5 kW	32 kW at 5.0 kW
Power amplifier efficiency	35%	31%	22%
Transmitter efficiency	27%	22%	15%
Cooling	Air and liquid	Air	Air

**THE FINAL POWER AMPLIFIER**

Digital television transmitters for either DTV or DVB-T have been in use for just a few years. Digital TV transmitter characteristics aren't known as completely as those of other mature power amplifiers. Although the 8VSB and OFDM modulation schemes are very different, they have high peak-to-average ratios. The probability of peaks occurring varies as the difference between the average level and peak observed level increases. As may be expected, as the difference between the two increases, the probability of a peak reaching that amplitude decreases. With an 8000-carrier OFDM signal, the maximum theoretical peak level can be as high as 38 dB, but the probability of this occurring is very small. With both systems, the method of signal generation normally limits the peak-to-average ratio to 8 dB for 8VSB and 12 dB for OFDM without degrading performance (Fig. 4).

To amplify these signals transparently would require a perfectly linear amplifier with a power capability of 8 dB to 12 dB higher than the average power output. For example, to

produce an average 1 kW output would require an amplifier of 6 kW to 16 kW peak.

**Combiners**

Power amplifiers, even those using vacuum devices of 100 kW or more, must sometimes be combined (external to the basic circuit power amplifier design). Various combiners of the following types are widely used:

- In-phase or star (impedance transformed to a single common point)
- Quadrature two-way (90°, hybrid, magic tee)
- Multiple input (bandwidth limited)
- Isolated or nonisolated input ports (reject loads used or not)
- Constant impedance (independent of sources)
- Nonreciprocal (circulator/isolator used)

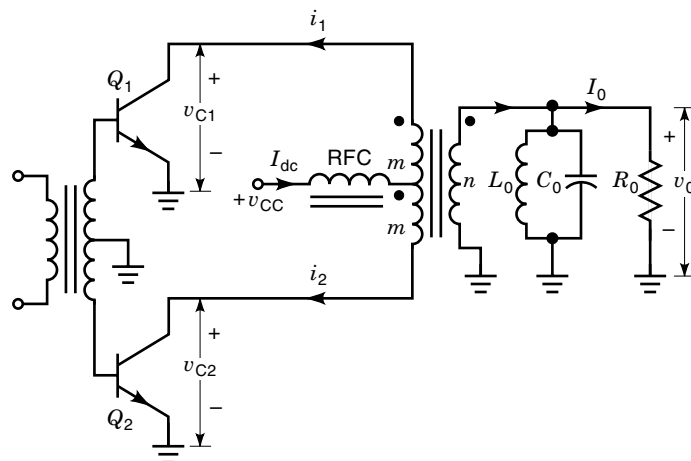

**Figure 3.** Simplified push-pull RF power amplifier.

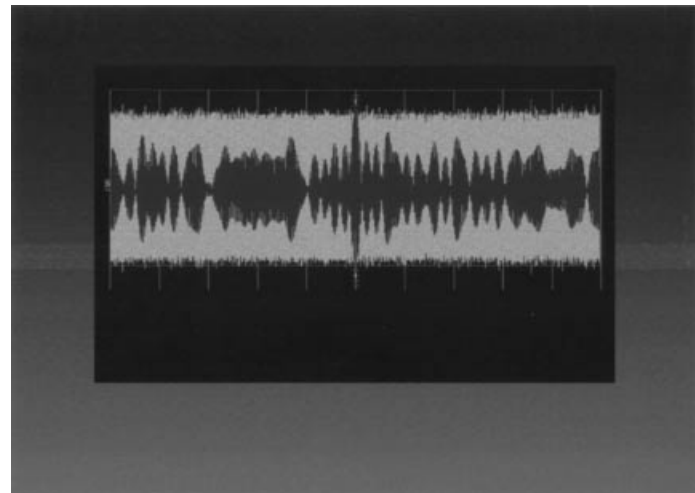

**Figure 4.** The DTV RF waveform.

The choice of combiner is usually determined by minimum insertion loss and the need for isolation from other circuits or surroundings. At high power, it is wise to not waste precious RF watts generated in power amplifiers as losses in combiners. Conductor losses prevail at higher powers, and thus air dielectric coax/stripline and waveguide are widely used to minimize losses.

By alternating both in-phase and quadrature combiners, arrangements that cancel certain intermodulation products can be made. This technique can be also used to divert RF that is intercepted by the antenna.

### Control and Monitoring: Protection of the PA

High-power amplifiers need various controls and subsequent monitoring. Typically the monitor and control is focused on three broad areas:

1. RF path
  - Drive power
  - Output power
  - Load VSWR
  - RF signal phase
2. Power supply(s)
  - Voltage
  - Current
  - Sequencing of supply turn on/off
3. Auxiliary
  - Dissipation
  - Temperature
  - Air/coolant flow
  - Arcing

The speed for the protection circuits in the power amplifier will depend on the robustness of the device. Very-high-power amplifiers will be operated near limits of performance, thus requiring fast and tight limit-setting circuits. Headroom in the PA is costly, and thus less costly protection circuits are preferred.

### Peak and Average Power

RF power amplifiers are limited by several factors, but dynamic range of the RF signal governs much of the limitation.

Generally, peak power determines the highest voltage/currents, whereas average power determines dissipation limit. The idealized digital signal has a higher peak-to-average ratio than is generally provided by many high power PAs. If the highest peak were preserved, then the penalty would be an inefficient PA. By permitting some saturation and attendant nonlinearities, a nonideal but practical signal can be transmitted with reasonable cost and efficiency.

The 8VSB DTV signal has a peak-to-average ratio in excess of 8 dB. To observe the high state, peak cannot be captured and measured easily. To reach this peak may take a long time. Instrumentation used to measure ordinary highly repetitive signals will mislead the uninformed. This unusual phenomenon is caused by the number of combinations of digital states and the sequences that are possible. Finding that combination may take hours. As a result, the data lost by distorting these occasional symbols can be corrected by the Forward Error Correction (FEC) codes. Tests indicate that a transmitted signal limited to 6 dB to 7 dB peak-to-average power ratio (Fig. 5) does not generate excessively uncorrectable IPs, and the receiver FEC can correct these errors. Similarly, OFDM has an even higher peak-to-average ratio. Two varieties of OFDM systems employ either 2000 or 8000 carriers. On average, half of the carriers would be on, whereas the peak would be all carriers on. The dynamic range extends from all carriers on to all carriers off. This very wide dynamic RF range and high peak-to-average ratio can be improved by not allowing certain states to exist to give high peaks and to let the FEC handle those occasional peaks that get clipped.

### Efficiency and Dissipation

Knowing the average power output and efficiency of a PA, the dissipation can be computed. This dissipation may be limited by the power output, the cooling mechanism, the device, or the peak-to-average ratio. Efficiency has been measured for both Class AB vacuum and solid-state amplifiers (Table 1). Efficiency is typically 25% to 35% of average output power. (Note: Higher efficiencies have been measured but at intolerable distortions.) This means that as much as three times as much power may be dissipated in the power amplifier as is delivered to the load. Misleading is the high peak-to-average

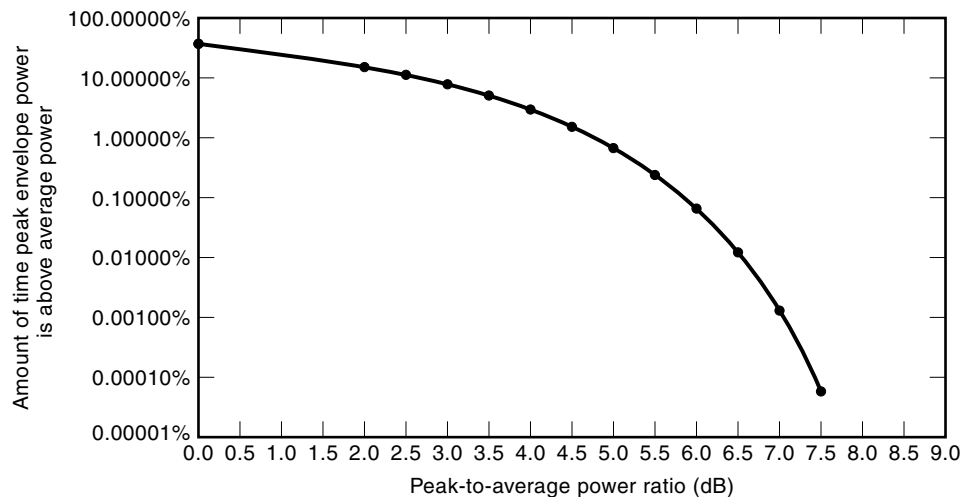

Figure 5. Distribution of peak power.

**Table 2. Efficiency for Various Classes of Operation**

Class of Operation	Ideal Maximum Efficiency (%)
A	12.5
B	78
A/B	12–78
C	100
D	100

power ratio, perhaps leading one to quickly predict a low dissipation. One view is to consider that the Class AB amplifier signal dwells in the low-efficiency Class A most of the time thus creating the lowered efficiency; when the signal dwells briefly at the higher-efficiency, Class B peaks.

### PRECORRECTION CIRCUITS

Powerful amplifiers characteristically modify the input signal in undesirable ways. High-power stages with little effect on the RF signal can be built, but they are not practical in terms of cost or efficiency. By choosing the design of a PA with limited but known distortion characteristics, one can use a number of ways to precorrect or correct these problems.

#### Frequency

The PA may exhibit ripple, passband tilt, or band edge problems. This is most notable in tube amplifiers using tuned cavities to extract the RF beam energy. This is often corrected by complementary tuning in the low-power drive. As the power amplifier reaches saturation, the frequency response often changes, thus complicating the correction process.

#### Amplitude

A PA can have multiple sources of deviations from linear (power in versus power out). These nonlinearities can include saturation compression, Class B crossover distortion, or feedback/neutralization. These problems may be corrected with complementary circuits using diodes with multiple amplitude breakpoints. These circuits are implemented at lower powers ahead of the PA.

#### Phase or Group Delay

Power amplifier characterizations that focus only on amplitude come up short. Digital TV is both amplitude- and phase-modulated, and thus PA phase distortions limit performance, too. Phase problems are corrected by using all pass networks that exhibit tunable delay variations without amplitude variations. Usually, several of these networks are inserted at IF and have tunable characteristics over the RF band.

#### Analog Feedback

One of the oldest forms of distortion reduction is feedback. By sampling the amplified output, inverting it, and applying it to the input, linearity can be improved. The most common feedback in solid-state amplifiers is to leave some unbypassed resistance in the emitter (or drain). This may be done inside the

transistor package. Similar feedback may be done with vacuum tubes, but some reduction in gain is required with each analog feedback scheme. It is also possible to neutralize the reactive feedback mechanism to improve the linearity characteristics. These techniques call for identifying the feedback path element and determining the best way to compensate this element reactively.

#### Feed Forward

Feed forward has become highly developed. This technique is widely used in smaller amplifiers where very high linearity is required. Widely used is a method of distortion reduction using “feed forward.” There are many novel ways to accomplish feed forward, depending on the performance required. The simple form of feed forward takes a sample of the output signal from the PA, subtracts a sample of the input signal, linearly amplifies the result, and reinserts this correction into the delayed output (Fig. 6). The result is a highly corrected, linear RF output but with a lower power than the original capability of the PA.

#### Digital Feedback

Digital feedback can be used if the output signal can be compared to the internally generated modulator signal and an error signal can be derived. This error signal is digitized and is then used to “distort or precorrect” the digital signal in a manner that linearizes the transmitter. Two general classes of errors are linear and nonlinear. Linear errors are those that do not vary with signal strength. The linear errors are frequency response and group delay. Nonlinear errors are those caused by the internal mixing action of nonlinear  $V_i/V_o$  response amplifiers.

Linear errors cause the digital constellation to be less defined, and hence demodulation uncertainties give rise to bit errors. This is shown in Fig. 7 for 8VSB.

- Phase shift (group delay) across the channel bandwidth and amplitude compression are common characteristics of power amplifiers. Similarly, filters with in-channel rip-

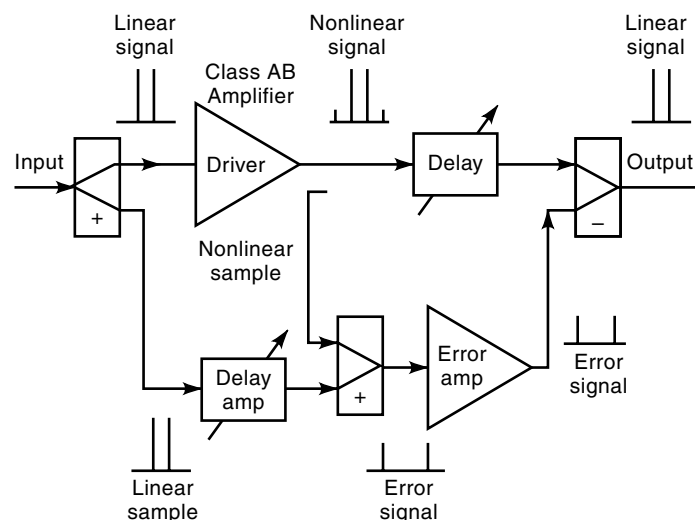
**Figure 6.** Feed forward block diagram.

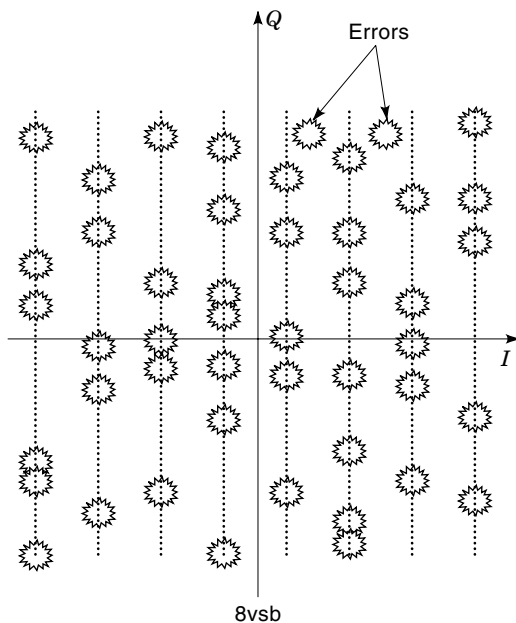

Figure 7. Constellation errors.

ple responses and sharp cutoffs affect group delay, giving rise to linear errors.

- Nonlinear errors are typically caused by amplifiers with gain compression and crossover distortion. Response such as that shown in Fig. 8 are what may be present in a typical efficient power amplifier.
- These nonlinear errors generate IPs that may either degrade the desired signal or create interference with an adjacent service.

OUTPUT FILTER

The high-power amplifiers all generate significant IP levels that are both in-band and out-of-band. The in-band IPs act as noise to degrade the signal-to-noise (S/N) ratio of the system. The IPs that are adjacent to the occupied band interfere with other services such as other TV channels. To minimize out-of-

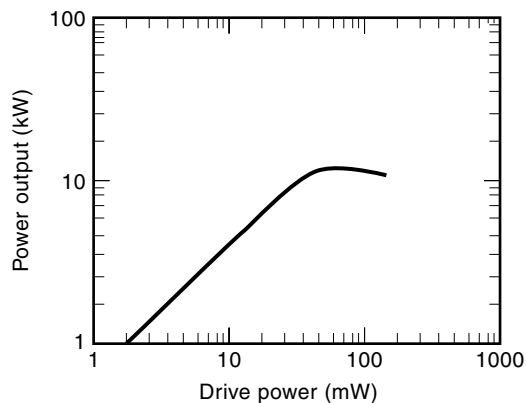

Figure 8.  $P_{in}$  versus  $P_{out}$  for a power amplifier.

band IPs and other interference problems, using an output band-pass filter can improve the IPs. These filters degrade the digital TV signal by adding amplitude and group delay distortions. These filters are generally sharp-skirted filters to effect the IPs within 1 MHz of the channel edge. These sharp skirts are more of an impact on group delay than amplitude, and thus additional precorrection must be added for this high-power band-pass filter.

To achieve the needed response, a many-pole filter must be used. A demanding filter may have a response as shown in Fig. 9.

The need and use of these types of filters is shown in Fig. 10. Here the amplifier is solid-state and has little bandwidth narrowing at the output. Placing a filter (not that of Fig. 9) can limit adjacent channel IPs significantly.

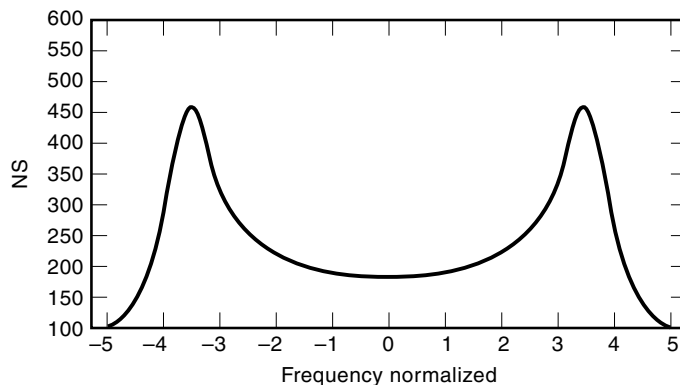
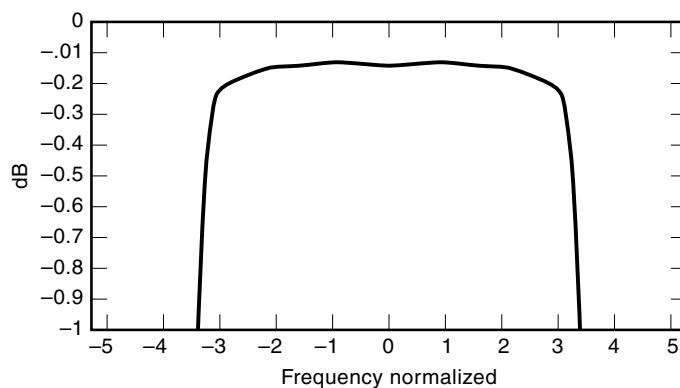
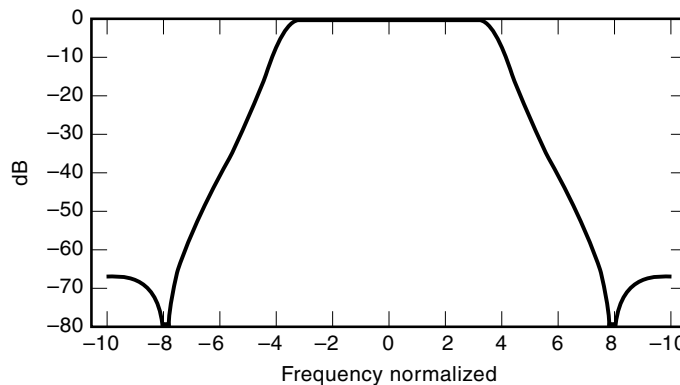
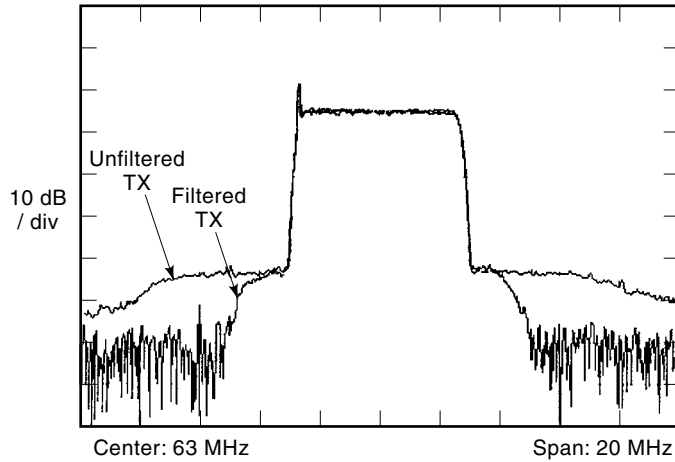

Figure 9. Bandpass filter response.



**Figure 10.** Filtered and unfiltered transmitter.

### PUTTING IT ALL TOGETHER

Digital television transmitters are generally linear amplifiers using frequencies that terrestrial analog TV uses today. Thus the “transmission layer” is used to deliver the “transport layer” digital payload, MPEG 2. After generating the RF signal (8VSB or OFDM) at some low power, it is necessary to provide linear amplification. Examples of this are the IOT PA and the solid-state PA. Results of 8VSB generation, precorrection, and filtering are shown in Figs. 11 and 12.



**Figure 11.** IOT power amplifier output without filtering.



**Figure 12.** Solid state power amplifier output without filtering.

### SUMMARY

Digital television has revolutionized our thinking about services to the home. Terrestrial delivery will be by means similar to analog TV. That is linearly amplifying a digital signal and then directing this power by antenna systems typically located 1000 ft above the served community. The purpose of the digital transmitter (power amplifiers and excitors) is to reproduce this signal faithfully and within the limits of broadcasters’ financial means.

### ACKNOWLEDGMENTS

The author acknowledges the contributions of many colleagues from numerous parts of the industry for advancing digital television.

### BIBLIOGRAPHY

- Advanced Television Test Center, *Digital HDTV Grand Alliance System*, Advanced Television Test Center, 1995.
- Advanced Television Test Center, *Digital HDTV Grand Alliance System, Record of Test Results*, Advanced TV Test Center.



- K. B. Benson and D. G. Fink, *HDTV Advanced Television for the 1990s*, New York: McGraw-Hill, 1991.
- K. K. Clarke and D. T. Hess, *Communications Circuits: Analysis and Design*, Reading, MA: Addison-Wesley, 1971.
- H. L. Krauss, C. W. Bostian, and F. H. Raab, *Solid State Radio Engineering*, New York: Wiley, 1980.
- National Association of Broadcasters, *Engineering Handbook, 8th ed.*, Washington, DC: NAB, 1992.
- F. G. Stremmer, *Introduction to Communications Systems, 3rd ed.*, Reading, MA: Addison-Wesley, 1990.
- M. Schwartz, *Information Transmission Modulation and Noise, 4th ed.*, New York: McGraw-Hill, 1990.
- R. E. Ziemer and W. H. Tranter, *Principles of Communications, 2nd ed.*, Boston: Houghton Mifflin, 1985.
- W. Y. Zou and Y. Wu, COFDM: An overview. *IEEE Trans. Broadcast.*, **41**: 1–8, 1995.

ROBERT WEIRATHER  
Harris Corporation