

# **AT** MICROFICHE REFERENCE LIBRARY

A project of Volunteers in Asia

Better Tools for the Job: Specifications for Hand  
Tools and Equipment

by: William Armstrong

Published by:

Intermediate Technology Publications, Ltd.  
9 King Street  
London WC2E 8HN  
United Kingdom

Available from:

Intermediate Technology Publications, Ltd.  
9 King Street  
London WC2E 8HN  
United Kingdom

Reproduced by permission of Intermediate  
Technology Publications, Ltd.

Reproduction of this microfiche document in any  
form is subject to the same restrictions as those  
of the original document.

# BETTER TOOLS FOR THE JOB SPECIFICATIONS FOR HAND TOOLS AND EQUIPMENT

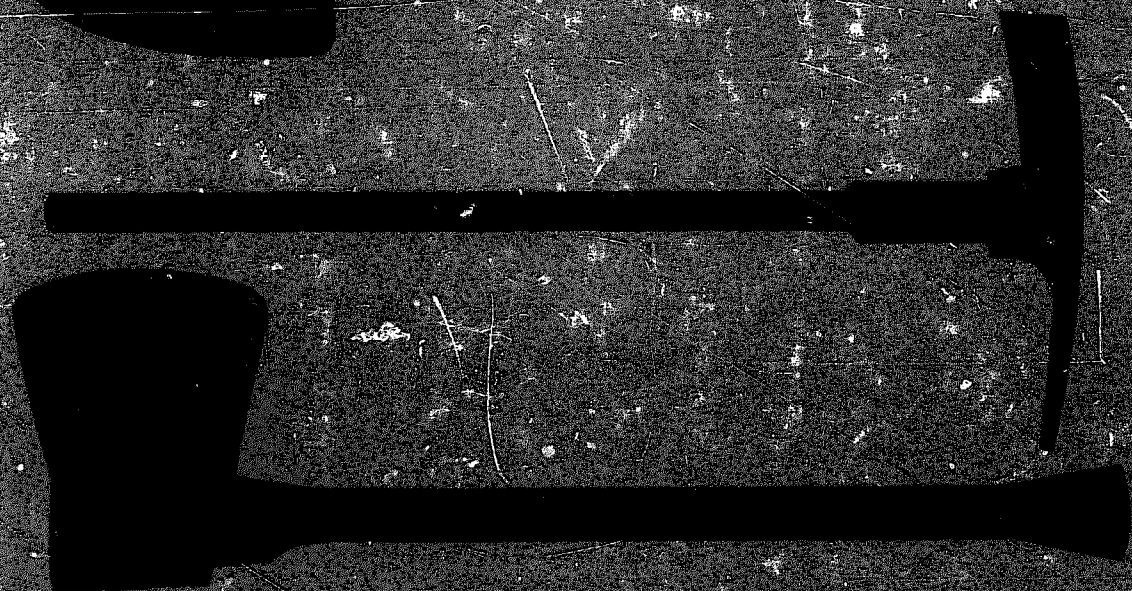
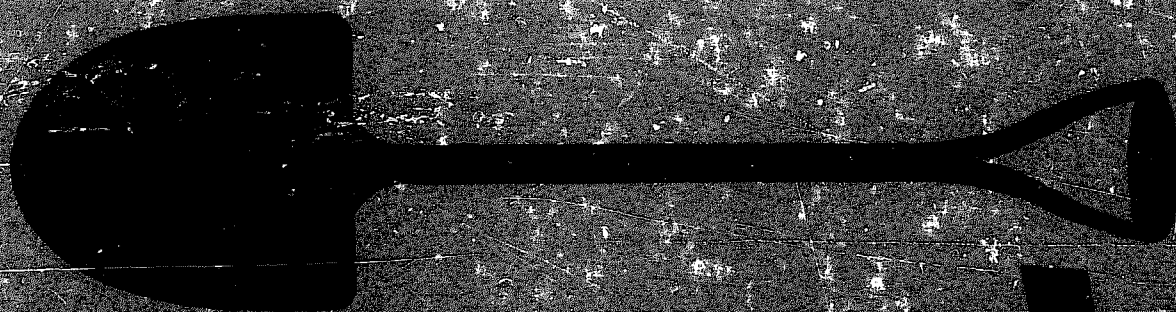

**WILLIAM ARMSTRONG**



These simple specifications for hand tools and equipment were developed in connection with the Kenya Rural Access Roads Programme. Started in 1975, the plan covers the building of some 15000 kilometres of simple unsealed roads in remote parts of the country using *labour intensive* methods during an approximate 10 year period.

It will be appreciated that such a project calls for the use of very large quantities of hand tools such as shovels, jembes, etc., and simple equipment such as wheelbarrows. At the outset of the RAR Programme the quality of these items was, in general, very poor, leading to breakages, supply difficulties, and low productivity in the field.

A Technology Unit attached to the Ministry of Works in Nairobi worked intensively on the upgrading of tool and equipment quality. These specifications, though originally applied to the Kenyan road programme, are equally applicable to other countries for labour intensive projects. The policy of buying tools and equipment by tender at the lowest quoted price is all too common and results in unsatisfactory quality. Tenders which include specifications like these to which manufacturers must conform result in tools which perform satisfactorily in the field.

The author is a member of the UK Institution of Mechanical Engineers and was retained as a consultant to the Kenya Rural Access Roads Programme.

ISBN 0 903031 71 X

Intermediate Technology Publications Ltd.,  
9 King Street, London WC2E 8HN, U.K.

# Better Tools for the Job

## Specifications for Hand Tools and Equipment

by  
William Armstrong  
B.Sc., M.I. Mech. E., M.R.Ae.S., M.S.A.E.

## Acknowledgements

Much of the work involved in developing these specifications was carried out by the Technology Unit attached to the Ministry of Works (MOW) in Kenya in connection with their Rural Access Roads Programme (RARP). This work and the helpful co-operation of many division heads of the MOW, together with the various RARP Officers, has been of great value.

Permission from the Government of Kenya to publish these simple specifications is gratefully acknowledged. The publication should result in real help becoming available to other countries engaged in similar labour intensive projects.

We would also like to thank representatives of the British Overseas Development Administration (ODA) both in the UK and in Kenya for their willing help and support.

The principal overseas consultants to the RARP were Scott Wilson Kirkpatrick & Partners of Basingstoke, England. Their initial conception of the need for specifications to upgrade the quality of the tools and equipment, and the very considerable work performed on the basic drafting, formed the fountain-head from which this publication emerged.

## Contents

Acknowledgements	4
1. Introduction	5
2. Specifications	6
3. Tool Handles	7
4. Wheelbarrows	8
5. Tractors and Trailers	9
6. Procurement, Stores, and Inspection	11
7. Maintenance in the field	12
Detailed Specifications:	
105 Shovel	14
106 Plain Jembe (Hoe)	16
107 Wheelbarrow (TU Model)	18
108 Fork Jembe	22
109 Crowbar	24
110 Trailer (5 tonne tipping)	25
111 Panga	28
112 Mattock	30
113 Shovel Handle	33
114A Jembe/Fork Jembe Handle	34
114B Pick/Mattock Handle	35
114C Axe Handle	36
114E Sledgehammer Handle	37
115 Axe	38
116 Pickaxe	40
117 Spreader (Rake)	42
118 Rammer	43

### ERRATUM

Please note that on Page 27:

APPENDIX TO SPECIFICATION No. 110

#### Drawings

- d. Hydraulic quick-release coupling, including self-closing gap  
should read self-closing cap not gap.

## 1. Introduction

The simple specifications for hand tools and equipment contained in this publication and the various notes relating to them were developed in connection with the Kenya Rural Access Roads Programme. This programme is a Government of Kenya (Ministry of Works) project supported by the World Bank, the British Government, USAID, and certain other Governments. Started in 1975, the plan was to build some 15,000 kilometres of simple unsealed roads in remote parts of the country using *labour intensive* methods during an approximate 10 year period. It is anticipated that over 10,000 people will be employed at the peak. Besides helping to reduce unemployment the programme has socio/economic merits in opening up remote areas, thus stimulating agricultural production and aiding education and medical care.

It will be appreciated that such a project calls for the use of very large quantities of hand tools such as shovels, jembes, etc., and simple equipment such as wheelbarrows. At the outset of the RARP the quality of these items was, in general, very poor leading to breakages, supply difficulties, and low productivity in the field. The basic reason for this very unsatisfactory situation was the practice of buying tools and equipment by tender at the lowest quoted price, resulting in the provision of tools of poor design which lacked strength and durability.

Regrettably this same policy of buying at lowest tender price is common in many developing countries, and results in similar unsatisfactory performances when the tools and equipment are put to work in the field.

Attached to the Kenya MOW in Nairobi was a Technology Unit which among other functions worked intensively on the upgrading of tool and equipment quality. By the end of 1978 this work had drawn to a successful conclusion and the simple specifications and other data in this book record the information developed, so that it is now available for *labour intensive* projects of many types in other countries.

It may be added that insofar as the Kenya RARP is concerned, work done on tool and equipment improvement and the use of these specifications when buying has been a major factor in eliminating shortages, reducing wear and breakages in the field, and increasing productivity. Thus the work has been cost effective and hand tools and equipment are no longer a delaying factor in the programme.

## 2. Specifications

The full list of simple specifications 105-118 is given in the contents section at the beginning of the book.

It should be emphasised that these simple specifications are not intended to replace the more detailed national or international specifications such as BSS, SAE, etc, nor do they cut across the work performed by any Bureau of Standards. Rather, they represent practical and manageable information (together with simple drawings) which can be used commercially for buying, inspection, and testing, thus ensuring that the various items procured will be durable and give good productivity in service.

In order to obtain good quality durable hand tools the use of steel to reasonably controlled specifications is essential. The strength and behaviour of steel depends on its chemical composition (and heat treatment where relevant), and for this reason the required chemical composition of the steel forms part of each hand tool specification.

In the absence of a local steel industry much of the steel will have to be imported, a situation which applies particularly to the special alloy steel needed, for example, for axe manufacture (Specification 115).

At first sight the inclusion of chemical compositions in the specifications might appear to involve complications in the form of analysis for inspection purposes. Fortunately, however, there is a good correlation between the strength of steel and its hardness, and it is for this reason that hardness figures are included in each hand tool specification. The equipment needed for hardness checking (covering only 0.2% of items received – see section 6) is fairly simple and inexpensive and may be located in the store's facilities. Briefly, the checking process consists of pressing a diamond or hardened ball into the steel with a definite load. The diameter of the indentation gives the required correlation with the strength of the steel, based on standard tables.

Thus the need for chemical analysis can be reduced to occasional random checks, probably carried out at the local university, or similar institution.

It will be noted that each specification calls for the tool to be marked clearly with the specification number and the manufacturer's name and/or trademark. These points are important for keeping track of tools in the field and discouraging the introduction of low grade non-specified items.



### 3. Tool Handles

Experience in several developing countries has indicated that a very large proportion of the problems encountered with hand tools in the field (on road, irrigation, and construction projects, for example) arise from the use of handles made from cheap *unseasoned* softwood, coupled with poor manufacturing quality. Breakages, loose tool heads, and unsatisfactory grips are typical problems, leading to poor productivity and waste of time.

This is surprising since suitable hardwoods are widely available, seasoning can be carried out naturally if kilns are not in use, and there appears generally to be adequate manufacturing capability either by machine, or, in rural areas, by manual methods.

Thus the manufacture of tool handles to specification is a vital and relatively easy step in the upgrading of hand tool quality and productivity in the field. The cost increase for a "specified" handle as compared with a "cheap" handle is modest, and no other single step can return such high dividends in terms of cost effectiveness and productivity as the manufacture of tool handles to specification from *seasoned* hardwood.

It is for this reason that specifications 113, 114A, 114B, 114C, 114E, covering handles for various types of tools are included in this publication.

Suitable hardwoods will have specific gravity 0.66-0.80\* after seasoning and will preferably be long grained. Seasoning should be to a moisture content of 20% maximum, either by kiln or natural means. Natural seasoning may take about seven weeks. In view of the very large variety of hardwoods in different parts of the world it is recommended that the selection of appropriate types for tool handles, be discussed and agreed with the Government Forestry Department (or similar official body) in each particular country.

In some countries manufacturing industries may have special profile turning lathes available on which tool handles can readily be manufactured. However, rural skills should not be overlooked and satisfactory handles can usually be produced by hand in rural areas. It is important that seasoned wood of the appropriate type be used — not just a branch cut off a convenient tree! To this end it may be desirable to supply the rural workers with standardised blocks of seasoned hardwood from some central (probably Government) source. For example for the jembe (hoe) handle, specification 114A, the standardised blocks would need to be 950mm x 62mm x 50mm.

A word of caution about axe handles, specification 114C. The attachment to the axe, specification 115, is vitally important and includes a wedge for assembly. The manufacture of axe handles and fitting them to the axe heads is preferably a job for experienced specialists.

\*Note: Specific gravity 0.66-0.80 corresponds to 41-50 lbs per cubic foot.

## 4. Wheelbarrows

It is difficult to visualise any labour intensive project which does not involve wheelbarrows to a considerable extent. In the course of the tool and equipment upgrading work for the Kenya RAR Programme it proved impossible to find a wheelbarrow in East Africa with satisfactory strength and life expectancy, apart from one or two very expensive imported items.

Accordingly the TU wheelbarrow was designed and tested, using readily available hardwood for the handles and paying particular attention to the wheel/axle/tyre assembly – a major weakness in most designs.

The field tests proved satisfactory, the costs were economic (though higher than some local poor quality wheelbarrows) and the item was put into quantity production with local commercial organisations.

All this formed the background of specification 107 (including drawings TF5 and TF7), which shows the design and construction of the TU wheelbarrow in sufficient detail to enable it to be manufactured in any part of the world.

The tyre was made extra wide to give a good "footprint", and of solid rubber for ease of production and elimination of field maintenance (inflation) problems.

The two nylon/molybdenum disulphide plain bearings will almost certainly be imported (as in Kenya), but as they amount to only 1% of the overall cost this can be considered a very advantageous trade-off for the much easier "wheeling" when fully laden, and the greatly increased (maintenance free) life which results from their inclusion in the design.

Wheelbarrows with crude wheel/axle arrangements are difficult to push due to excessive bearing friction, particularly with a full load. This usually results in the operator only partially filling the barrow with consequent loss of productivity.

## 5. Trailers and Tractors

Many labour intensive projects, particularly in rural areas, involve the moving of earth, gravel, etc, in bulk over considerable distances.

Specification 110 covers a five tonne (hydraulic) tipping trailer developed in connection with the Kenya Rural Access Roads Programme. The specification is detailed and thorough yet the trailer involves no extraordinary skills as regards manufacture, although it is likely that the hydraulic rams and the tyres (with tubes) will have to be imported.

This development was an interesting and most constructive exercise with co-operation between the Kenya MOW, the Technology Unit attached to it, and certain commercial enterprises. The design proved very satisfactory on test and the trailer has been produced in quantity by three commercial firms. Field experience has shown that trailers built to specification 110 can be relied upon for good performance and durability under arduous operating conditions.

The appendix to specification 110 covers various matters which are important when trailers are being bought in quantity.

Since the use of the above trailers clearly involves tractors a few notes regarding the tractor/trailer combination may not be out of place.

### a. *Compatibility*

An important aspect of the combination involving attention to towing hitch, hydraulic reservoir capacity, load transfer (particularly on steep down grades), power to weight ratios, etc.

### b. *Tractor Power*

Adequate power (including allowance for power drop-off if working at altitude) is a fairly obvious essential. Nevertheless it is also possible to overdo the tractor size with a consequent penalty by way of increased costs.

### c. *Tyres and Tubes*

Tubeless tyres are completely unsatisfactory owing to air leakage following inevitable wheel rim distortion damage in service, hence the inclusion of tyres *and* tubes in specification 110.

### d. *Hitch*

The hitch must be made from good quality heat treated steel, otherwise rapid wear will take place in service.

### e. *Hydraulic Hoses*

Hose and pipe lengths and runs should be checked and any sharp bends or sharp radii should be corrected. Suitable clips and supports should be provided for hoses. Any sharp edges on which the hoses might chafe must be eliminated.

Leaking joints are an obvious but oft-neglected cause of hydraulic system problems.

### f. Hydraulic Disconnect Coupling

This device automatically seals off the two sides of the hydraulic system when the tractor and trailer are separated. Per se the coupling is usually satisfactory but the danger of dirt getting into the hydraulic system is self-evident, particularly since the hose attached to the stationary trailer is often simply dropped on to the ground after being disconnected.

The drawing below indicates in schematic form a design to overcome this problem. It is, of course, essential that all components in the arrangement are robust, and also that operators are instructed to make use of the correct procedures!

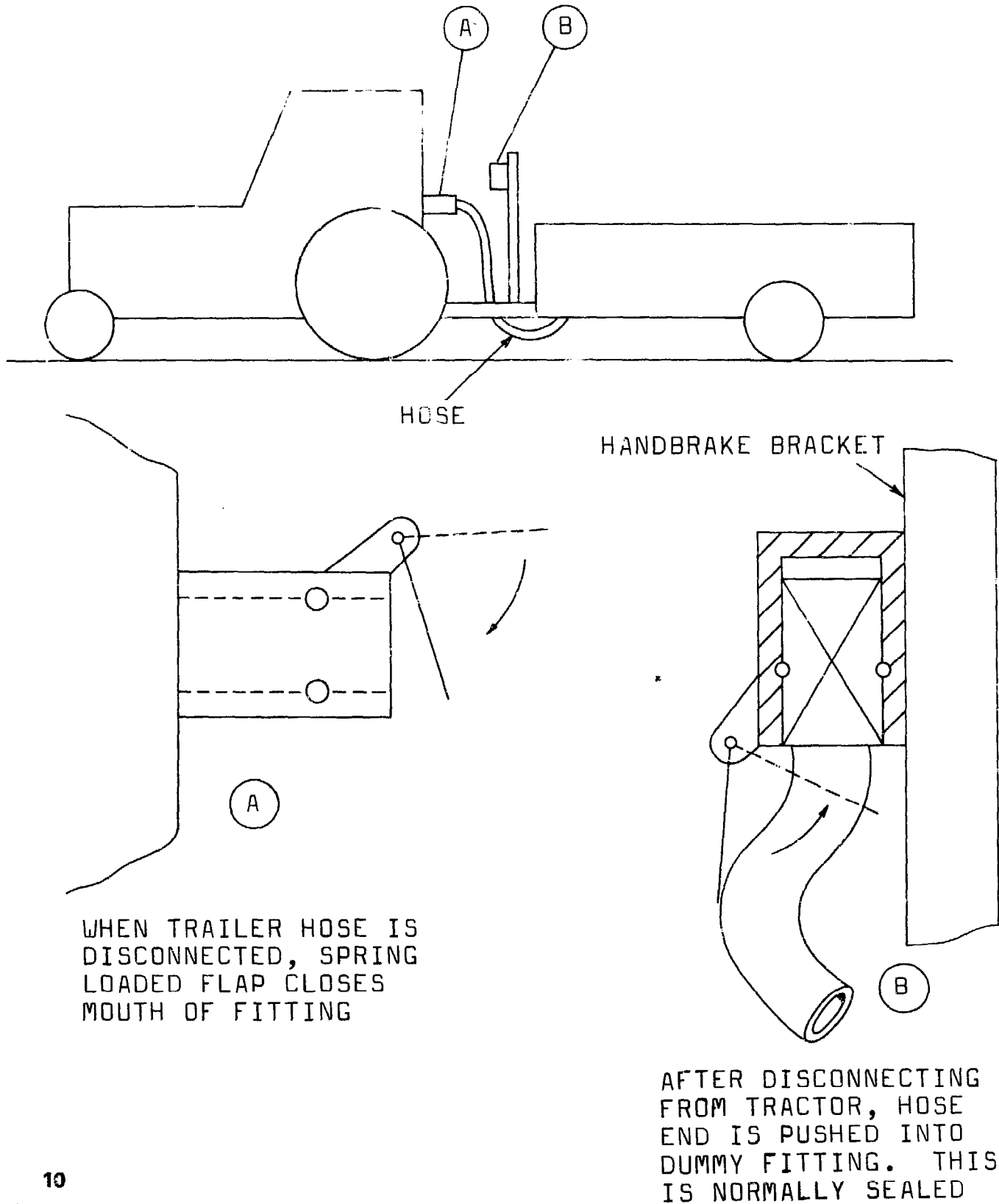

## 6. Procurement, Stores, and Inspection

Although this publication sets out to deal principally with specifications for simple hand tools and equipment a few comments on the above subjects will be relevant.

Indeed, the initial function of the simple specifications is to accompany *all* requests for supply quotations from manufacturers (or importers).

If quotations are requested, for example for "1000 Shovels", there is every chance that the articles bought will be at the cheapest price – and quite unsuitable for service in the field!

If, however, the quotation requests go out as "1000 Shovels to specification 105 attached" the manufacturer (or importer) will have to ensure that the shovels are made from good quality steel of correct thickness, that the dimensions are in line with the drawing, and that quality in general is sufficiently good to pass the inspection tests.

Shovels bought in this manner will be more expensive (maybe 30%) than the unspecified articles, but will have an operating life probably 500% longer besides considerably increasing productivity in service.

Thus the principle of "buying to specification" can be regarded as very cost effective.

As regards stores, the efficiency of any labour intensive project will be greatly increased by the provision of proper tool storage facilities and effective systems for the control of receiving (including inspection) and issuing to the field.

Before tools are put into stores it is, of course, essential that they be inspected to ensure that they are in line with the drawings and to specification generally. Thus the use of the simple specifications at "receiving inspection" becomes a second major aspect of their value. It will be noted that each specification has a drawing attached and includes a simple mechanical test procedure. In the case of hand tools a hardness checking figure is also indicated, to which reference was made earlier in Section 2.

It is felt that the following percentage checks at stores receiving will generally be adequate:

Hardness	0.2%
Strength	0.2%
Dimensional	0.4%

Thus taking a batch of 1000 shovels or jembes the quantities for checking, selected at random, would be two for strength, two for hardness, and four for dimensions. This checking will (or should be) virtually non-destructive.



## 7. Maintenance in the Field

Although this subject is not directly related to the matter of specifications a few notes may be useful.

Assuming the specifications have been used for procurement and inspection into central stores there will be available for the particular project (road construction, irrigation, etc) a supply of good quality durable tools and simple equipment.

The field performance (life and productivity) will, as pointed out earlier, be greatly superior to that of unspecified "cheap" tools and equipment. This performance can be extended by the provision of elementary maintenance and repair facilities at field camps under the general control and supervision of the foreman. The basic equipment involved is simple and low priced, although the type will depend on the availability or otherwise of a supply of electricity.

Such "self-help" jobs as sharpening of jembes using honing stones, fitting of new handles to shovels etc, repairs to wheelbarrows, riveting of new panga handles, and similar elementary maintenance work should be well within the capacity of field camp personnel, and will be very worthwhile (cost effective) in extending the life and productivity of the good quality items which the project management has provided in the first place, i.e. has bought to specification.

A note of warning regarding welding. This is a job for operators who have had specialised training.

## DETAILED SPECIFICATIONS

## SPECIFICATION No. 105 — SHOVEL

*Note: Medium carbon steel is specified together with a minimum thickness of 1.75mm. Thinner material would prove unsatisfactory in service. Heat treatment is not considered necessary. Handles must be made from seasoned hardwood and sizes to give satisfactory strength are indicated.*

### **Materials**

Blades to be steel to the following specification:

Carbon <i>Percent</i>	Manganese <i>Percent</i>	Phosphorus <i>Percent</i>	Sulphur <i>Percent</i>
0.40/0.50	0.50/0.80	0.05 max	0.05 max

Handles to be hardwood, free from defects, and seasoned to not more than 20% moisture content.

### **Construction**

Blade and socket to be formed from one piece of steel 1.75mm minimum thickness, free from cracks or other defects. Hilt to be wooden T or metal Y (with wooden grip) as shown on Figure 2.

### **Strength and Hardness Tests**

- a. With the tool clamped as shown in Figure 3, a load of 50kg shall be gradually applied by suspension from the grip and maintained for two minutes. On removal of the load the tool shall show no signs of damage or loosening of any component part, nor shall there be any permanent set in excess of 25mm when measured at the grip.
- b. Hardness of blade to be 190-240 Brinell B.

### **Marking**

Shovels to be clearly and indelibly marked on the blade or socket with:

- a. Manufacturer's name and/or trademark.
- b. The figures 105.

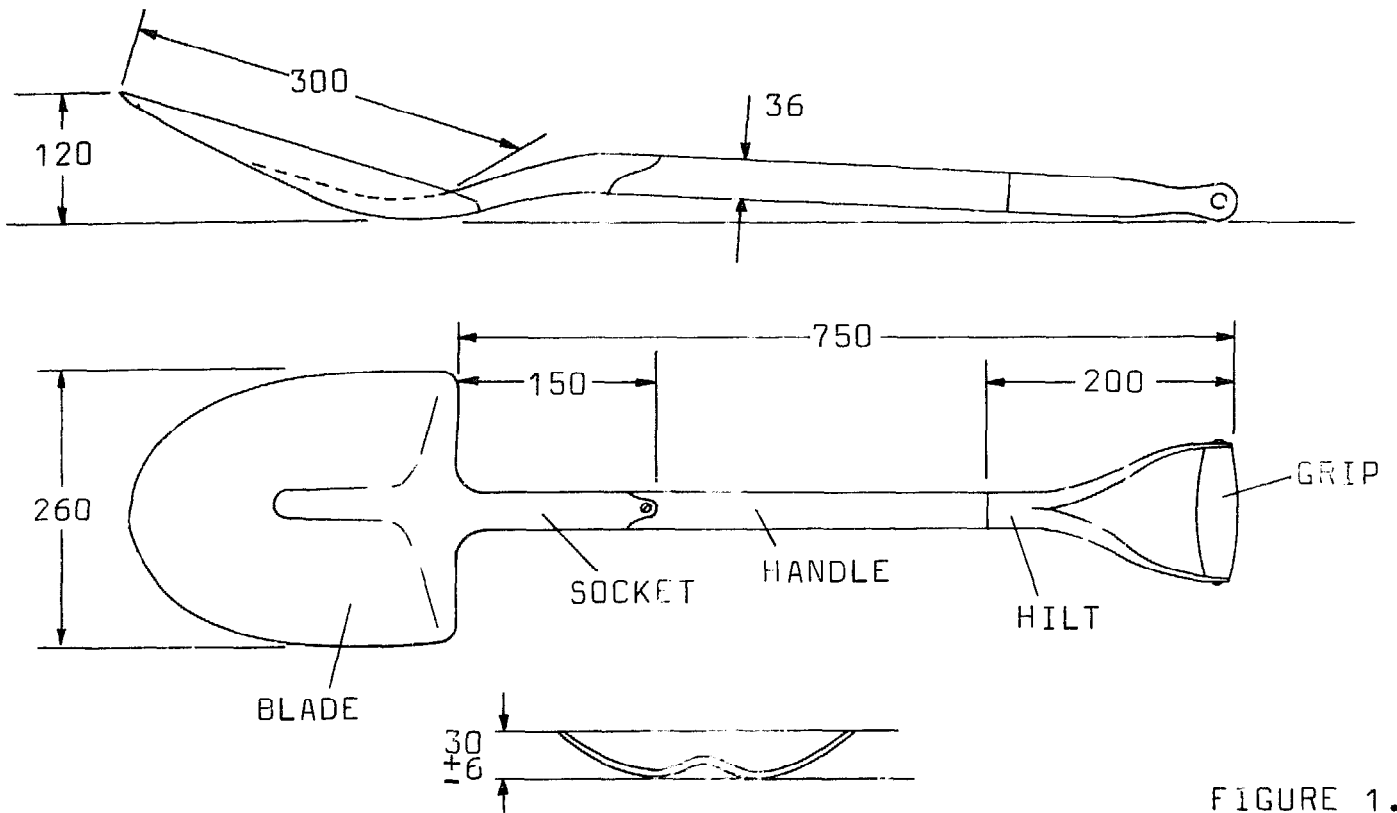

FIGURE 1.

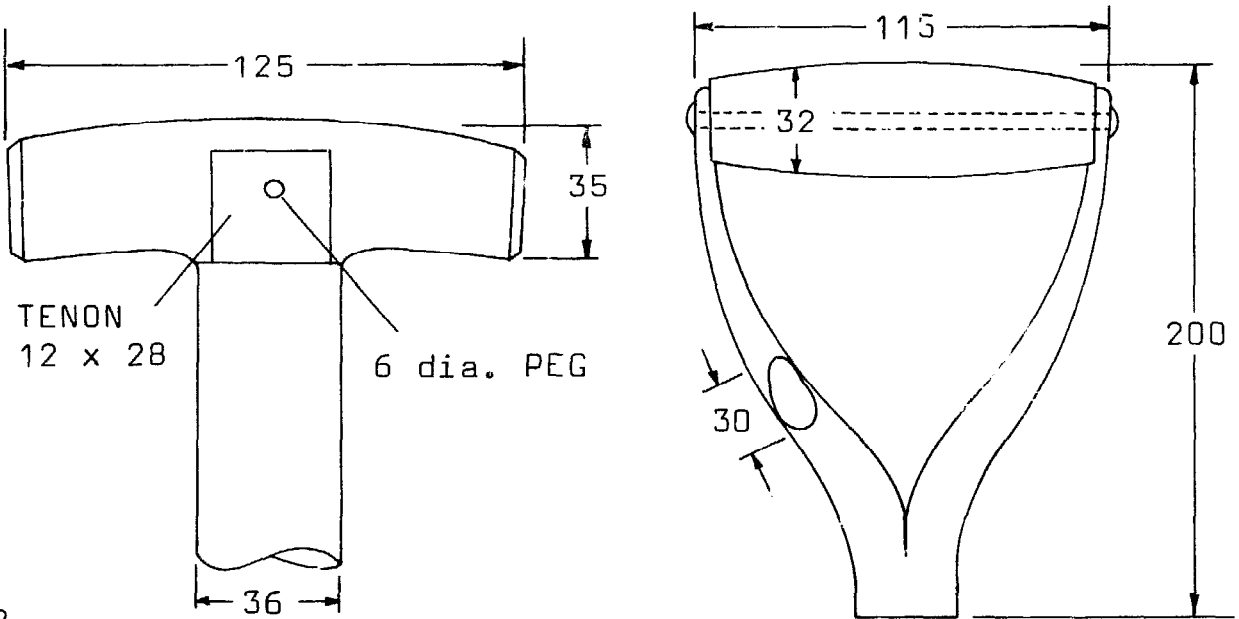

FIGURE 2.

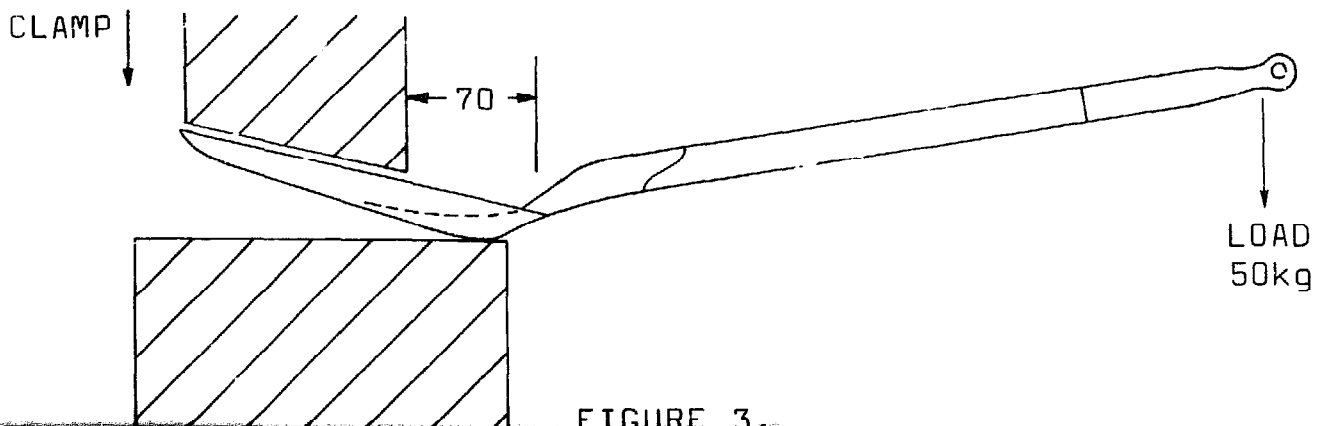

FIGURE 3.

## SPECIFICATION No. 106 — PLAIN JEMBE (HOE)

*Note: For effective life it is essential that this tool be forged from the medium carbon steel specified and heat treated as indicated.*

### **Weight**

1.5kg (+10%, -5%).

### **Material Specification (Steel)**

Carbon Percent	Manganese Percent	Phosphorus Percent	Sulphur Percent
0.40/0.50	0.50/0.80	0.05 max	0.05 max

### **Heat Treatment and Hardness**

After the forging has been normalised the lower part of the blade shall be hardened and tempered to give hardness within 50mm of the cutting edge of 40/46 Rockwell C. The hardened zone shall not extend nearer than half way to the eye.

### **Construction**

The forging must be symmetrical and free from flaws. All fins and flashes must be dressed off. The eye must be smooth internally, uniformly tapered, and must lie centrally in the forging. The cutting edge must be ground sharp.

### **Strength Test**

With a standard hardwood handle fitted and the tool clamped as shown on Figure 2 a load of 45kg shall be gradually applied by suspension at the handle end, and maintained for two minutes. On removal of the load the tool shall show no signs of damage to the head or loosening of the handle, nor shall there be any permanent set in excess of 25mm measured at the end of the handle.

### **Marking**

The forging shall be clearly and indelibly marked with the following:

- Manufacturer's name and/or trademark.
- The figures 106.
- The nominal weight

### **Preservative Treatment**

The head to be varnished all over.

*N.B.* The jembe may also be made of two-piece welded construction provided prior written approval of the design and material specifications is obtained. Such welded jembes must conform with all the requirements of specification No.106.



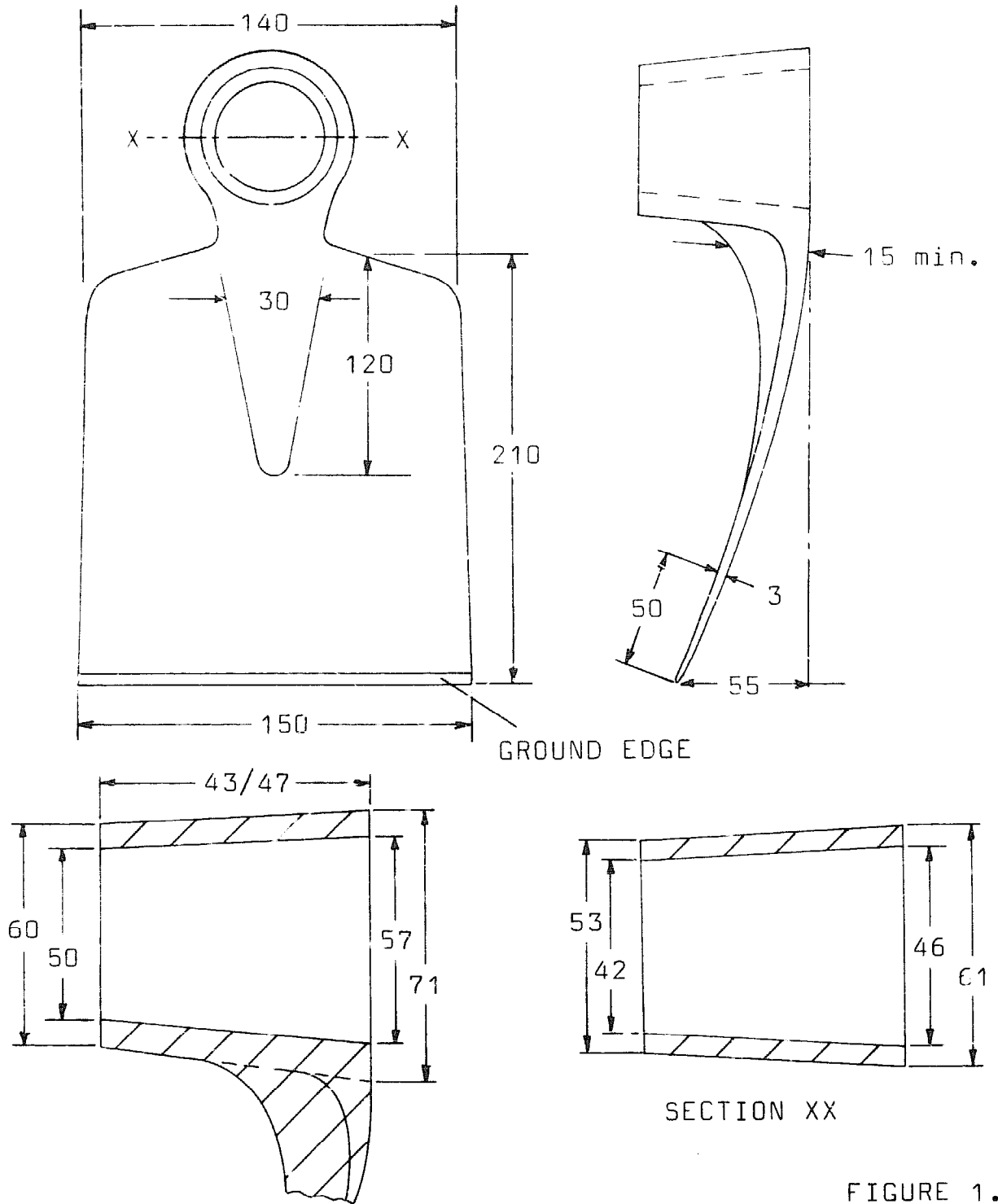
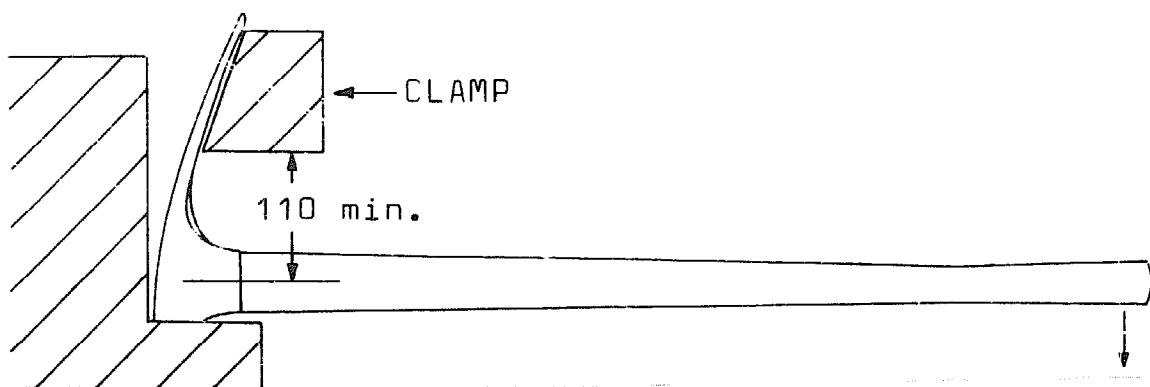

FIGURE 1.



## **SPECIFICATION No. 107 — WHEELBARROW (TU MODEL)**

### ***Handles***

Hardwood 40mm x 70mm, shaped appropriately at hand grips. Wood must be seasoned to not more than 20% moisture content.

### ***Body***

1.2mm (18 gauge) black iron folded and riveted, with 10mm reinforcing bar rolled into full perimeter of top edge. Struck capacity 70 litres.

### ***Body/Handle Fixing***

Four bolts, 10mm diameter, 100mm long, with washers 36mm x 1.5mm under "flat spherical" head of each bolt. Nuts with spring washers.

### ***Legs***

Two steel strips 6mm x 30mm bolted in place by body bolts. Two steel foot pads 5mm thick welded on.

### ***Front Braces***

Two steel strips 6mm x 30mm bolted in place with 10mm bolts.

### ***Cross Brace***

Two steel strips 6mm x 25mm bolted to legs with 8mm bolts 25mm long. Strips welded together at centre to form rigid X.

### ***Axle***

25mm diameter bright steel 220mm long, clamped to wooden frame by means of two steel caps 6mm x 30mm section and two steel load spreading pads 3mm x 30mm section, with 10mm bolts.

### ***Wheel***

Two 2mm pressed steel discs welded to tubular steel hub 36mm diameter, 145mm long, and clamped together by six bolts 8mm diameter, 12mm long, at 170mm pitch circle diameter. Two nylon/molybdenum disulphide flanged bearings 2mm thick and 25mm long pressed into ends of hub.

### ***Tyre***

Solid rubber 360mm diameter x 75mm wide. Tread pattern as appropriate. Inside diameter 220mm.

### ***Marking***

The wheelbarrow to be clearly and indelibly marked with:

- a. The manufacturer's name and/or trademark.
- b. The figures 107.

### ***Treatment***

Axle, two 2mm side thrust washers, and all bolts to have chemical rust preventative

SPECIFICATION NO.107

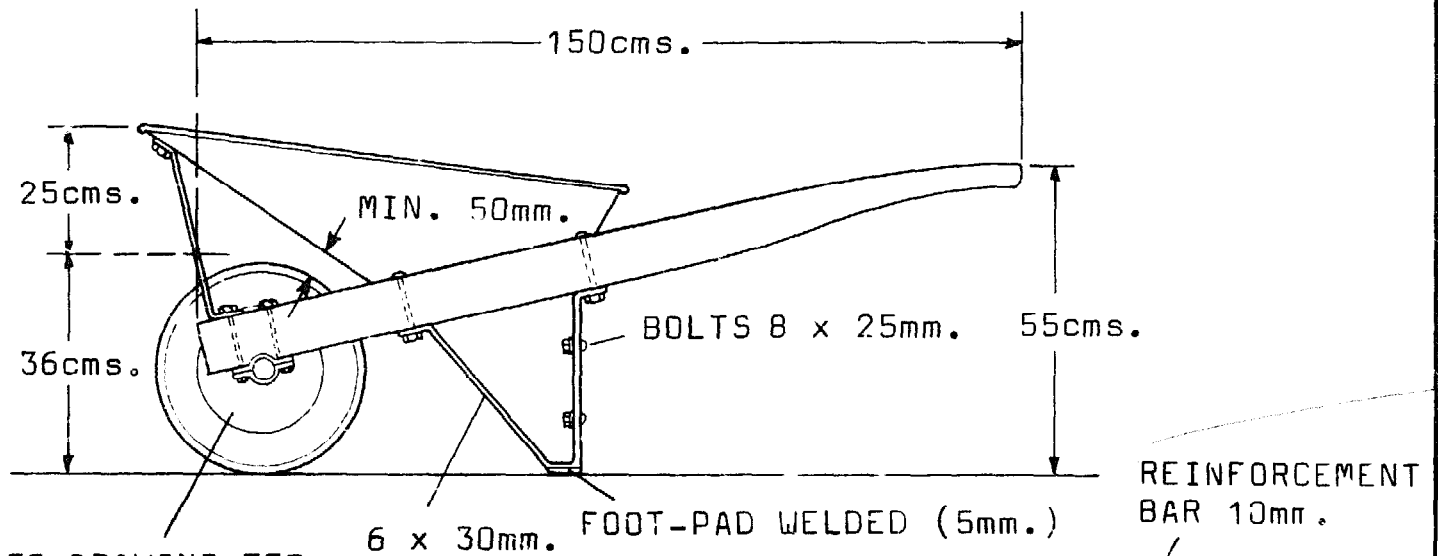

SEE DRAWING TF7  
FOR WHEEL AND AXLE

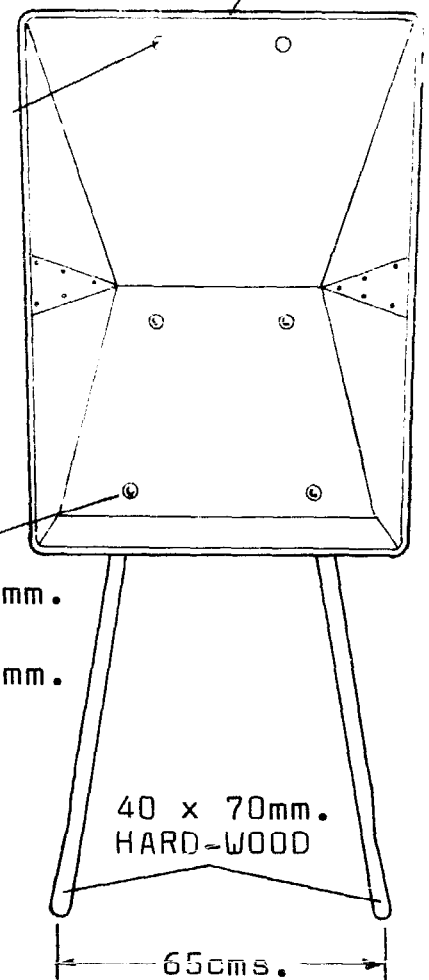
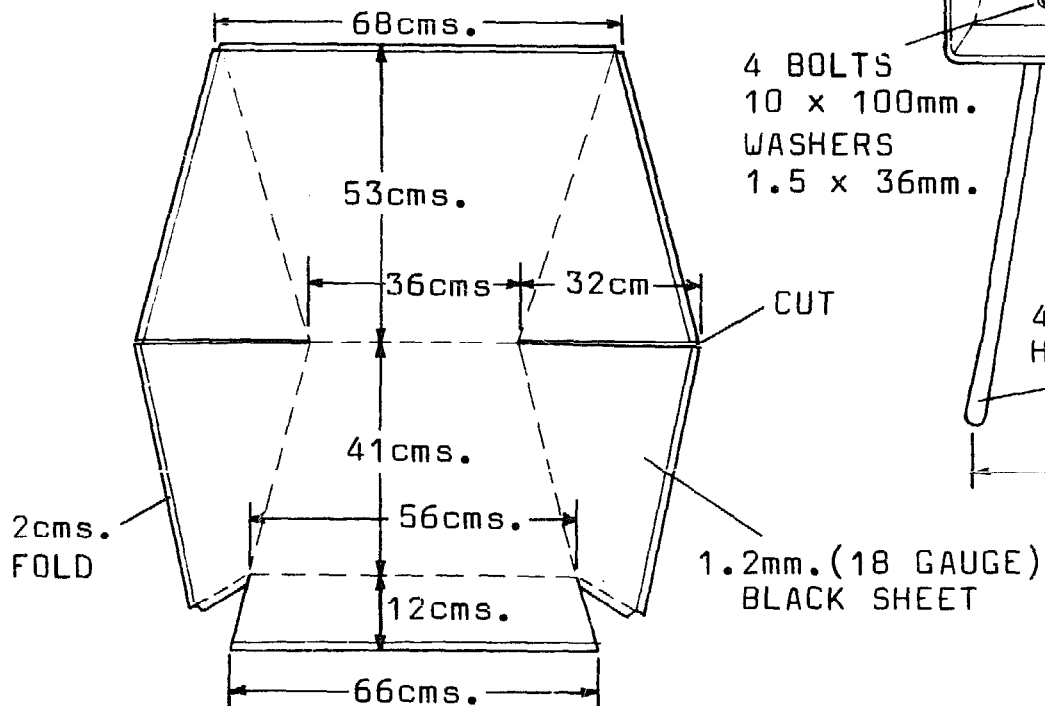
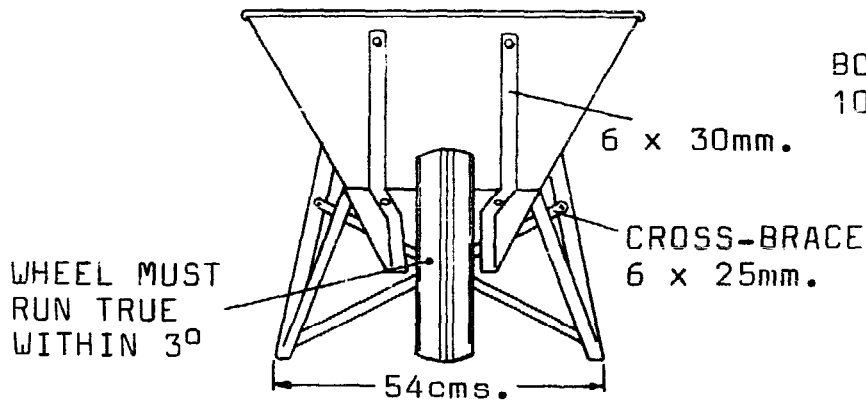

1.2mm. (18 GAUGE)  
BLACK SHEET

SPECIFICATION NO.107

SOLID RUBBER-TYRE  
75mm. WIDE  
360mm. DIAM.

WHEEL DISC  
2mm.

220mm DIAM.

6 BOLTS  
8 x 12mm.  
170mm. P.C.D.

HARDWOOD  
40 x 70mm.

WASHER (2mm.)

NYLON-BEARING

WELD

AXLE 25m

36mm.  
(APPROX.) END FLOAT 1mm. MAX.

145mm.  
(APPROX.)

FRONT-BRACE  
6 x 30mm.

SPRING-WASHERS

WASHER 1.5 x 30mm.

3 x 30mm.

BOLT

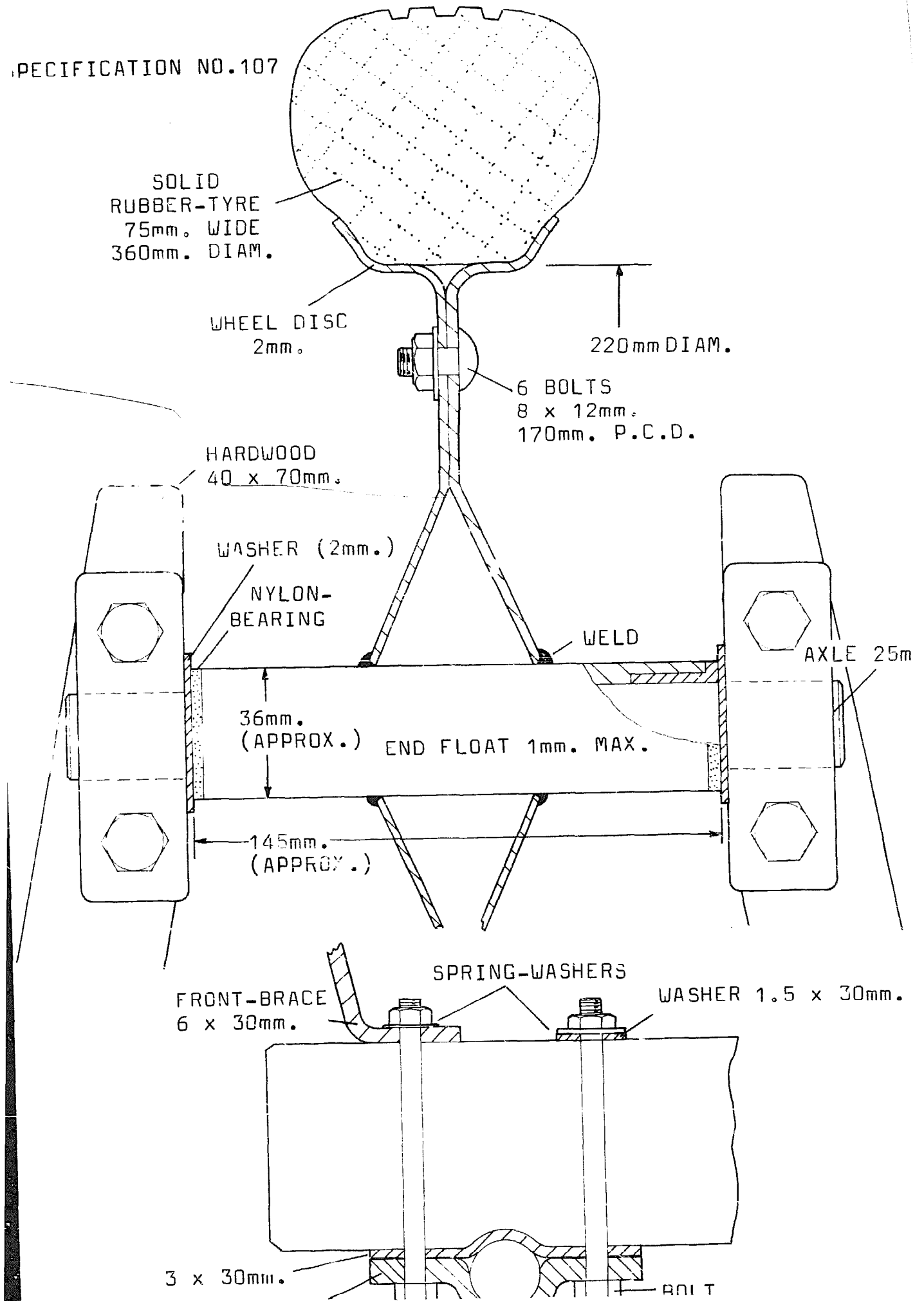

treatment before assembly. The wheelbarrow (with the exception of the tyre) to be cleaned, treated, and painted with one coat of preservative paint.

***N.B.***

- a. Minimum clearance between tyre and body to be 50mm.
- b. Two loose steel washers 2mm thick to be assembled between hub ends and wooden frames to provide endwise location of the wheel. End float to be 1mm maximum.
- c. After final assembly the wheel and tyre must run freely and true within three degrees.



## SPECIFICATION No. 108 — FORK JEMBE

*Note: For an effective life it is essential that this tool be forged from the medium carbon steel specified and heat treated as indicated.*

### **Weight**

To be 1.5kg (+10%, -5%)

### **Material Specification (Steel)**

Carbon <i>Percent</i>	Manganese <i>Percent</i>	Phosphorus <i>Percent</i>	Sulphur <i>Percent</i>
0.40/0.50	0.50/0.80	0.05 max	0.05 max

### **Heat Treatment and Hardness**

The forging shall be hardened and tempered to produce Rockwell C 25/30 at the shoulders increasing along the prongs to Rockwell C 45/50 within 50mm of the tips.

### **Construction**

The forging must be symmetrical and free from flaws. All fins and flashes must be dressed off. The eye must be smooth internally, uniformly tapered, and must lie centrally in the forging. The tips must be ground sharp.

### **Strength Test**

With a standard hardwood handle fitted and the tool clamped as shown on Figure 2 a load of 45kg shall be gradually applied by suspension at the end of the handle and maintained for two minutes. On removal of the load the tool shall show no signs of damage to the head or loosening of the handle, nor shall there be any permanent set in excess of 25mm measured at the handle end.

### **Marking**

The forging shall be clearly and indelibly marked with the following:

- a. Manufacturers name and/or trademark.
- b. The figures 108.
- c. The nominal weight of the head.

### **Preservative Treatment**

The head to be varnished all over.

### **N.B.**

The fork jembe may be made by welding the prongs to an eye forging, provided prior written approval of the design and material specifications is obtained. Such welded fork jembes must conform with all requirements of this specification No.108.

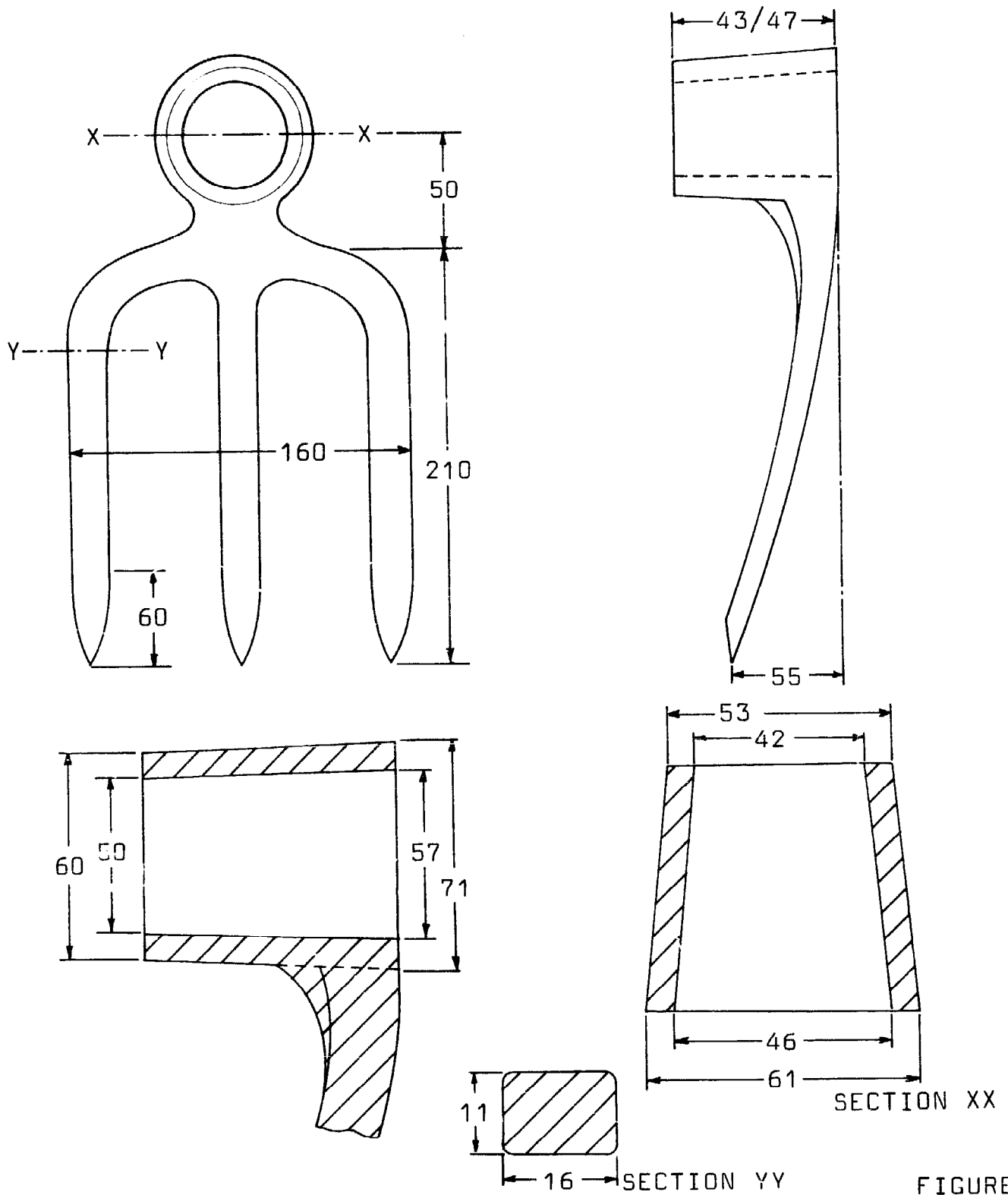
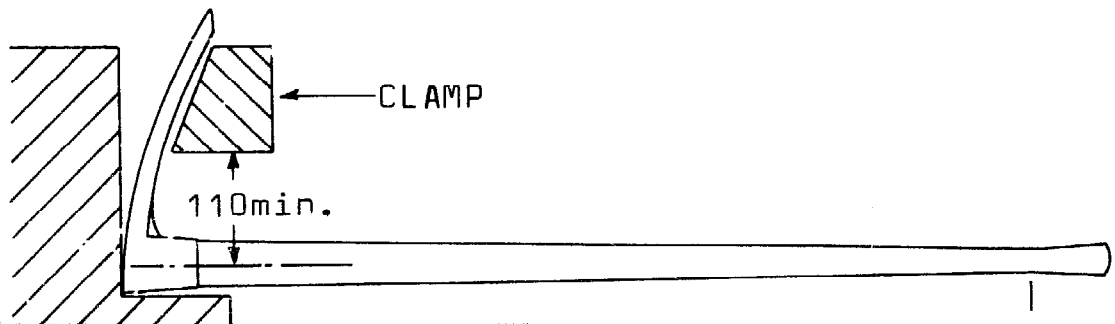

FIGURE 1.



## SPECIFICATION No. 109 – CROWBAR

*The crowbar is an essential tool in many labour intensive projects. Old scrap steel or concrete reinforcing bars are useless in the field. Crowbars made to this specification may appear somewhat costly initially but will be effective and long lasting in service.*

### **Description**

The crowbar to be 3cm diameter, 170cm long, shaped to a chisel form at one end and a four flat point at the other, as illustrated.

### **Material**

Steel with 0.45/0.55 carbon content, hardened and tempered to give Rockwell C 45/50 when checked at four random points along the piece.

### **Weight**

9kg approximately.

### **Marking**

The crowbar to be marked clearly and indelibly with the following:

- Manufacturer's name and/or trademark.
- The figures 109.

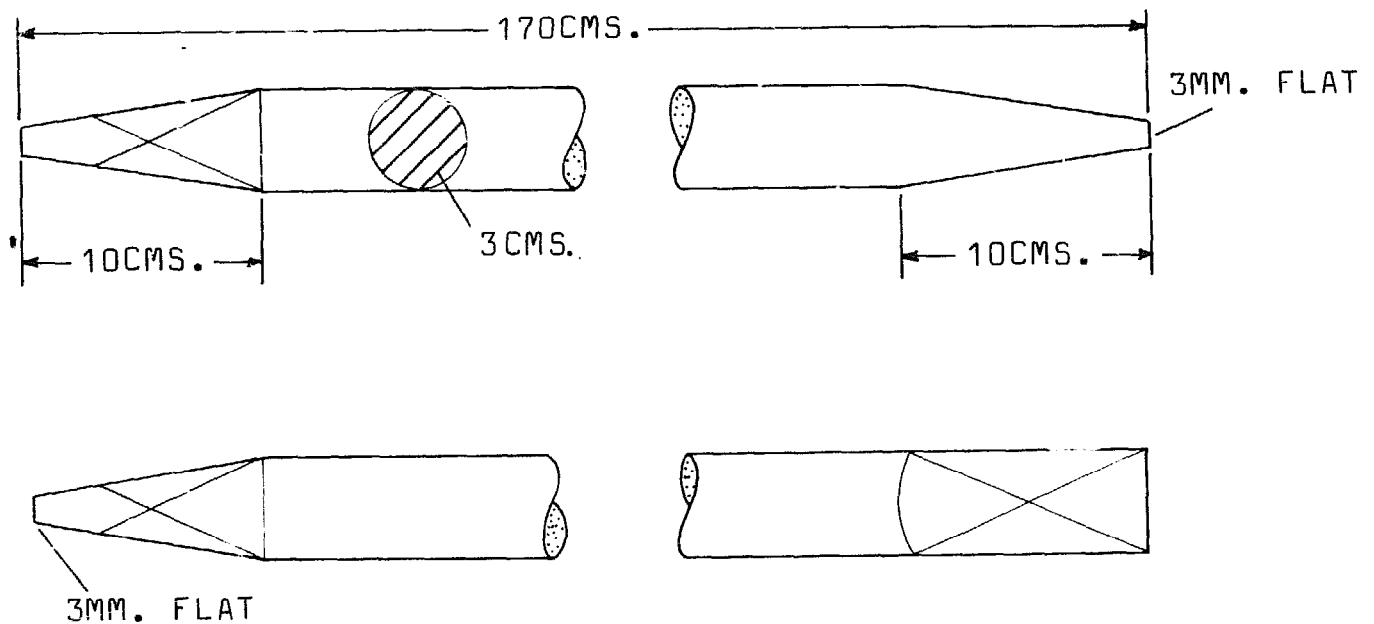

# SPECIFICATION No. 110 — TRAILER (5 TONNE TIPPING)

## **General**

The trailer shall be designed for heavy duty operations with a single axle and hydraulically operated rear tipping body. The payload capacity shall be five tonnes and the struck volumetric capacity 2.8 cubic metres.

The trailer shall be designed to be compatible in use with a specified 45 HP tractor, fitted with automatic hitch, and increased hydraulic fluid reservoir capacity to ensure full tipping angle in service.

## **Dimensions**

The maximum overall dimensions of the trailer body shall be as follows:

- a. Length 5000mm
- b. Width 2300mm
- c. Height 1250mm (measured at axle)

The axle shall be 70mm square (minimum) and so located that with the trailer fully loaded the load transferred to the tractor is 1.5 tonnes maximum/1.2 tonnes minimum.

The tipping angle shall be 60 degrees minimum.

A robust fixed skid type stand shall be fitted to the underside of the drawbar to enable the trailer to be hitched easily under soft ground conditions.

## **Construction details**

The chassis shall be fabricated from 150 x 75 x 18kg per metre (minimum) hot rolled mild steel channel with 0.22% carbon (max), 0.8% manganese (max), and 30 tons per square inch/4650kg per square centimetre (minimum) tensile strength.

The chassis shall include a boxed cross member to support and guide the body. Such cross member shall be sufficiently strong and rigid to support the fully laden body without distortion.

The body sub-frame shall be fabricated from 100 x 50 x 10kg per metre (minimum) hot rolled mild steel channel to the same chemical and strength specifications as the chassis.

The body hinge pin diameter shall be 35mm minimum.

The body floor shall be fabricated from 2mm (minimum) **high tensile** steel plate with 18 tons per square inch/2800kg per square centimetre (minimum) **yield** strength, in the form of individual plates extending across the full width of the trailer and reinforced at centres not exceeding 200mm.

The body sides and head-board shall be fabricated from 2mm mild steel plate having chemical and strength specifications as the chassis.

The body sides shall be extended rearwards a minimum of 100mm to provide protection for the tailgate, hinges, and locking device.

The tailgate shall be hinged at the top with engineered hinges and heavy duty brackets, and shall be fabricated from 3mm mild steel plate having chemical and strength specifications as the chassis.

The tailgate shall be removable.

A robust locking device shall be provided for the tailgate operated by means of a lever located at one side of the rear of the body, and incorporating a full width cross shaft.

The towing eye shall be of alloy steel heat treated to ensure negligible wear over a two year period of normal service.

The cross member on which the ram acts when tipping shall be of sufficiently strong section to eliminate distortion in service.

### ***Hydraulic equipment***

The hydraulic equipment fitted to the trailer must be compatible with the hydraulic system of the specified tractor.

A dummy quick-release type female coupling shall be fitted to the trailer headboard, with the opening vertically downwards, in such a position that the connecting hose may be plugged in easily when the trailer is unhitched from the tractor. The dummy female coupling must be permanently fitted with a very robust spring loaded cap which automatically closes off the opening when the hose is removed.

The ram shall be high lift, two stage, and chrome plated.

Hydraulic hoses shall be single wire braid reinforced, and routed to provide maximum protection from damage in arduous service.

### ***Tyres, wheels, and brakes***

Tyres must be fitted with tubes and shall be 11.5 x 15 (minimum) with a 10 ply (minimum) rating.

Wheels shall be of very robust type with standardised dimensions for fixing holes.

Mechanically actuated drum parking brakes with minimum diameter of 250mm and minimum width of 45mm shall be provided. The operating cables shall be sheathed and routed to ensure maximum protection under service conditions.

### ***Painting etc.***

The trailers shall be painted with one coat of red oxide primer and one coat of yellow gloss paint.

The trailers shall be fitted with reflecting chevrons and reflectors.



## APPENDIX TO SPECIFICATION No. 110

*Note: This relates to any tender for trailers.*

### ***Drawings***

The following drawings are required:

- a. General arrangement including side elevation, rear elevation, and plan (Scale 1:10 approximately).
- b. Tailgate locking device (Scale 1:2).
- c. Tailgate hinge (Scale 1:1).
- d. Hydraulic quick-release coupling, including self-closing gap (Scale 1:1).

### ***Special components***

Manufacturer's printed specifications and relevant drawings are required to cover:

- a. Hydraulic ram and hoses.
- b. Quick-release hydraulic couplings.
- c. Axle.
- d. Hub and wheel.

### ***Warranty***

12 months warranty against any problems or failures under normal operating conditions arising as a result of design, material, or manufacturing defects.

### ***Price stability***

The quoted price to be valid for 60 days from the tender closing date.

### ***Tractor hydraulic coupling***

The tenderer to be responsible for supplying and fitting quick release hydraulic couplings, together with self-closing caps, to the hydraulic systems of the specified tractors.

### ***Spare parts***

The following are required per 100 trailers:

- Tyre, tube, and wheel (20).
- Hub (complete) (5).
- Hub bearings (10 wheel sets).
- Wheel nuts (50).
- Hydraulic ram (10).
- Hydraulic hose (20).
- Quick-release hydraulic coupling with self-closing cap (15).
- Towing eye (10).
- Hinge pin (10).
- Brake cable (10).

## **SPECIFICATION No. 111 — PANGA OR MACHETE (46cm, HEAVY DUTY)**

*Note: The use of medium carbon steel and heat treatment as specified is essential to obtain a tool which will be effective in heavy service and will retain its cutting edge. Secure riveting of the hardwood handles is very important.*

### ***Materials***

Blades to be steel with carbon content 0.52/0.60, heat treated to Rockwell C 40/45 when checked at three points along the blade.

Rivets to be steel with maximum carbon content 0.15. Washers to be mild steel.

Handles to be hardwood seasoned to not more than 20% moisture content.

### ***Construction***

Handles to be machine riveted to the blade at three places — see Figure 2 for details. Blades to be ground to sharp edge.

### ***Test***

With blade inserted in 10mm wide slot 150mm deep a deflection of 45 degrees in each direction shall be applied without breakage or permanent set — see Figure 3.

### ***Preservative Treatment***

Blades to be varnished and greased.

### ***Marking***

Blades to be clearly and indelibly marked with:

- a. Manufacturer's name and/or trademark.
- b. The figures 111.

SPECIFICATION NO.111

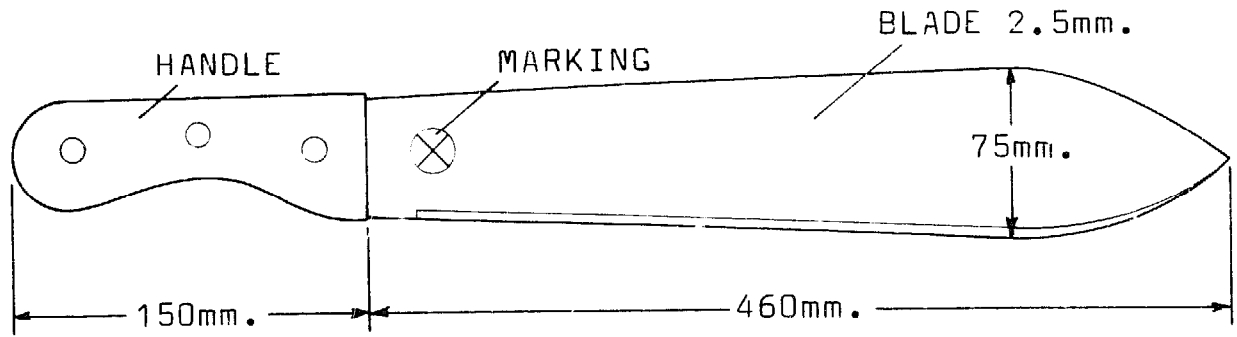
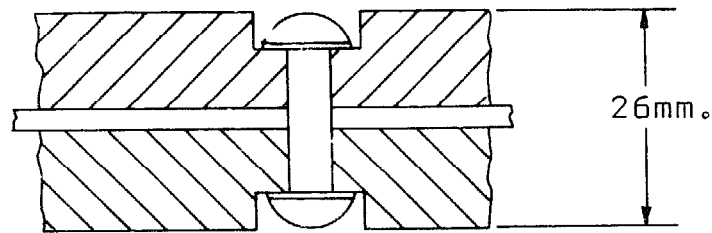
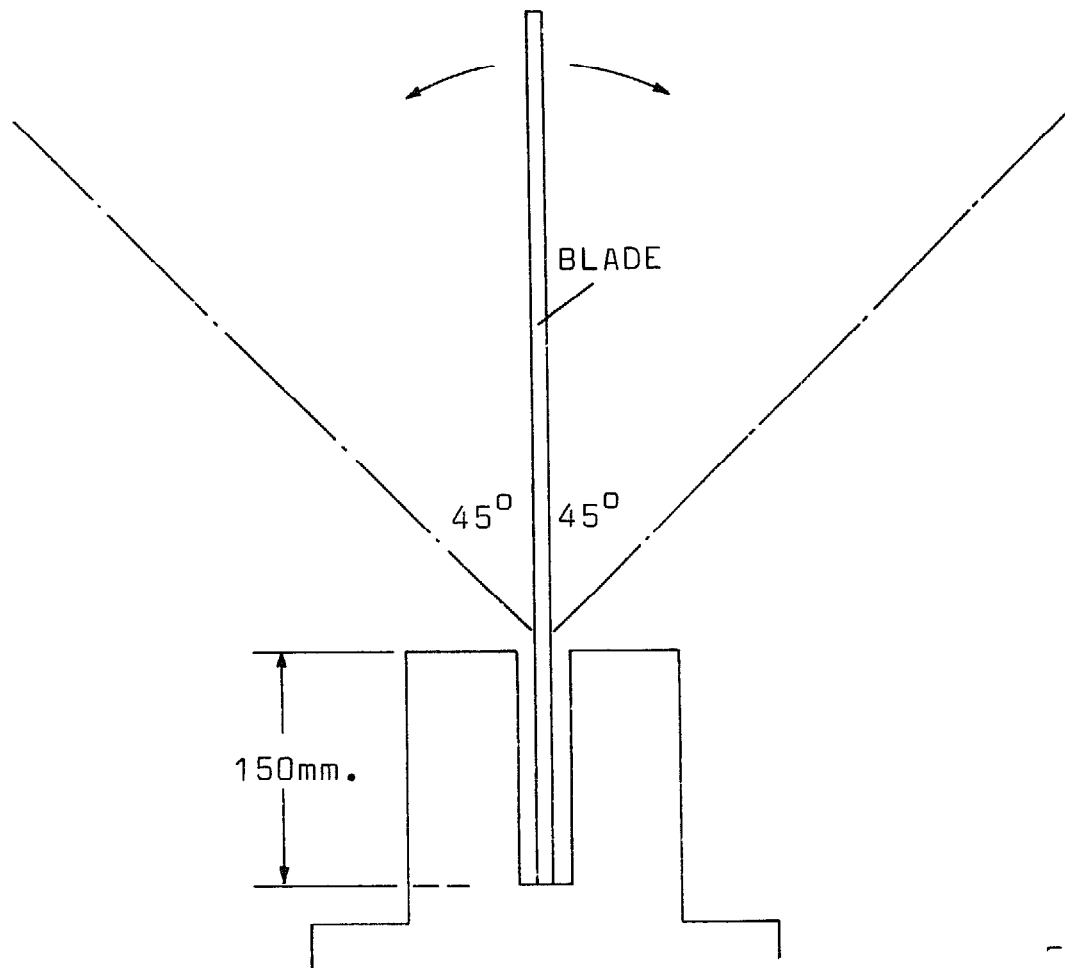

FIGURE 1.



RIVET 5mm. WASHERS 11 x 1.5mm.

FIGURE 2.



## SPECIFICATION No. 112 — MATTOCK

*Note: It is essential that mattocks be forged from the medium carbon steel specified and heat-treated as indicated.*

### *Weight*

2.5kg (+10%, -5%)

### *Material Specification (Steel)*

<i>Carbon Percent</i>	<i>Manganese Percent</i>	<i>Phosphorus Percent</i>	<i>Sulphur Percent</i>
0.40/0.50	0.50/0.80	0.05 max	0.05 max

### *Heat Treatment and Hardness*

The forging shall be hardened and tempered to produce Rockwell C 25/30 at the eye, increasing to Rockwell C 45/50 within 50mm of the cutting edges.

### *Construction*

The forging must be symmetrical and free from flaws. All fins and flashes must be dressed off. The eye must be smooth internally, uniformly tapered, and must lie centrally in the forging.

The thickness of the blades shall be greatest at the shoulders, decreasing towards the cutting edges which must be ground sharp.

### *Strength Test*

With a standard hardwood handle fitted and the tool clamped as shown on Figure 2 a load of 45kg shall be gradually applied by suspension at the end of the handle and maintained for two minutes. On removal of the load the tool shall show no signs of damage to the head or loosening of the handle, nor shall there be any permanent set in excess of 25mm measured at the handle end.

### *Marking*

The forging shall be clearly and indelibly marked with the following:

- Manufacturer's name and/or trademark.
- The figures 112.
- The nominal weight

### *Preservative Treatment*

The head to be varnished all over.

SPECIFICATION NO. 112

DIMENSIONS IN MM.

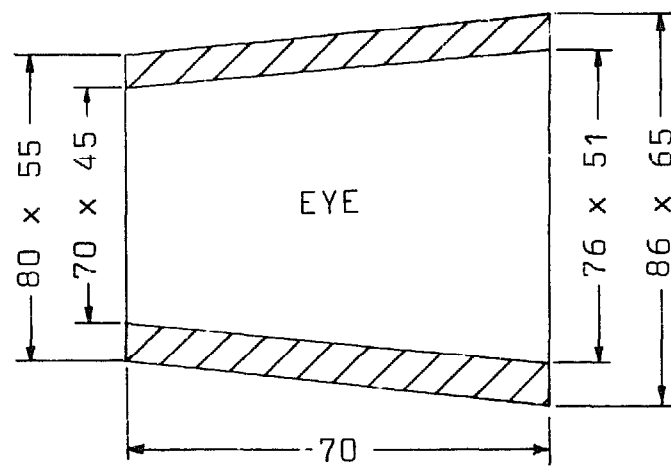
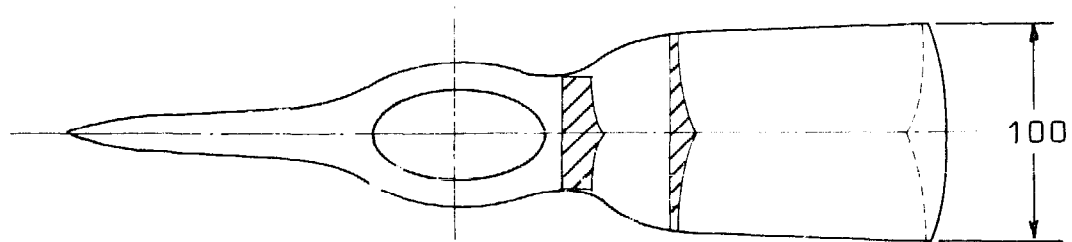
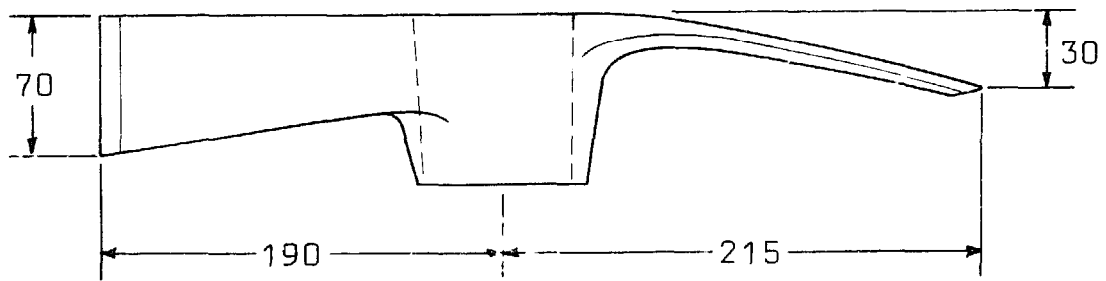

FIGURE 1.

SPECIFICATION NO.112

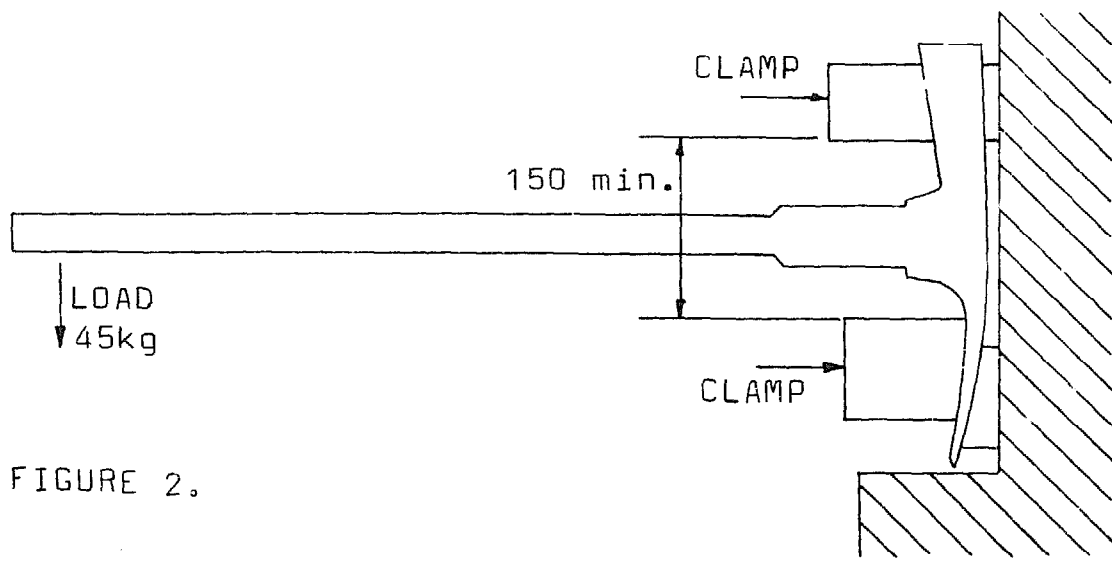

FIGURE 2.

# SPECIFICATION No. 113 — SHOVEL HANDLE

## *Material*

Hardwood seasoned to not more than 20% moisture content.

## *Testing*

With the plain end of the handle firmly clamped over a length of 150mm a load of 45 kilograms shall be gradually applied by suspension at the grip, with an offset from the handle centreline of 150mm. (This can be achieved conveniently by sliding a well-fitting tube over the 35mm grip diameter.)

There must be no failure, cracking, or permanent set in excess of 25mm on removal of the load.

## *Samples*

Any supplier must submit three samples for dimensional, material, and strength approval, before proceeding with production.

## *Marking*

Handles to be stamped 113 in bold figures.

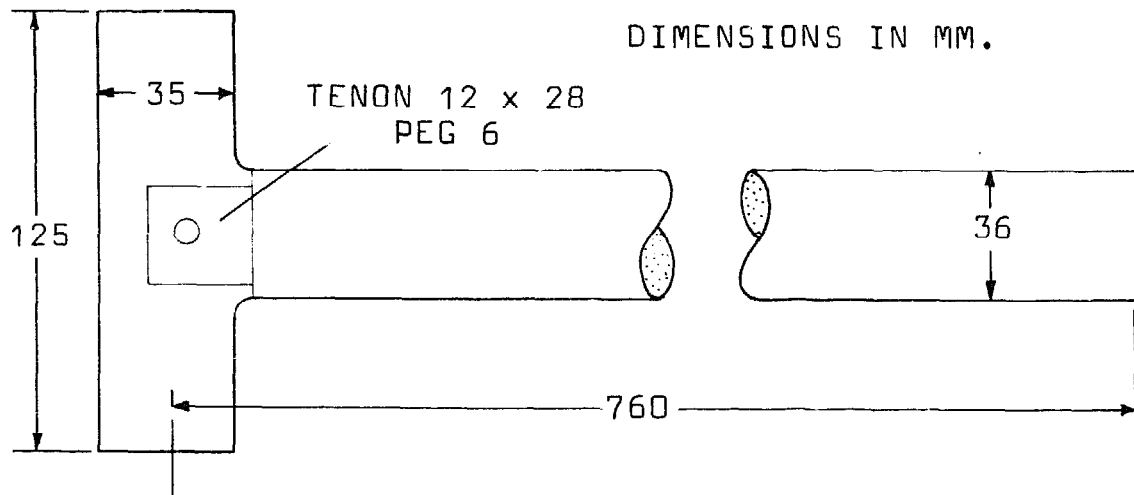

# SPECIFICATION No. 114A — JEMBE/FORK JEMBE HANDLE

## *Material*

Hardwood seasoned to not more than 20% moisture content.

## *Testing*

With the larger end clamped over a length of 120mm a load of 45 kilograms shall be gradually applied by suspension at the free end of the handle. There must be no failure, cracking, or permanent set in excess of 25mm on removal of the load.

## *Samples*

Any supplier must submit three samples for dimensional, material, and strength approval, before proceeding with production.

## *Marking*

Handles to be stamped 114A in bold figures.

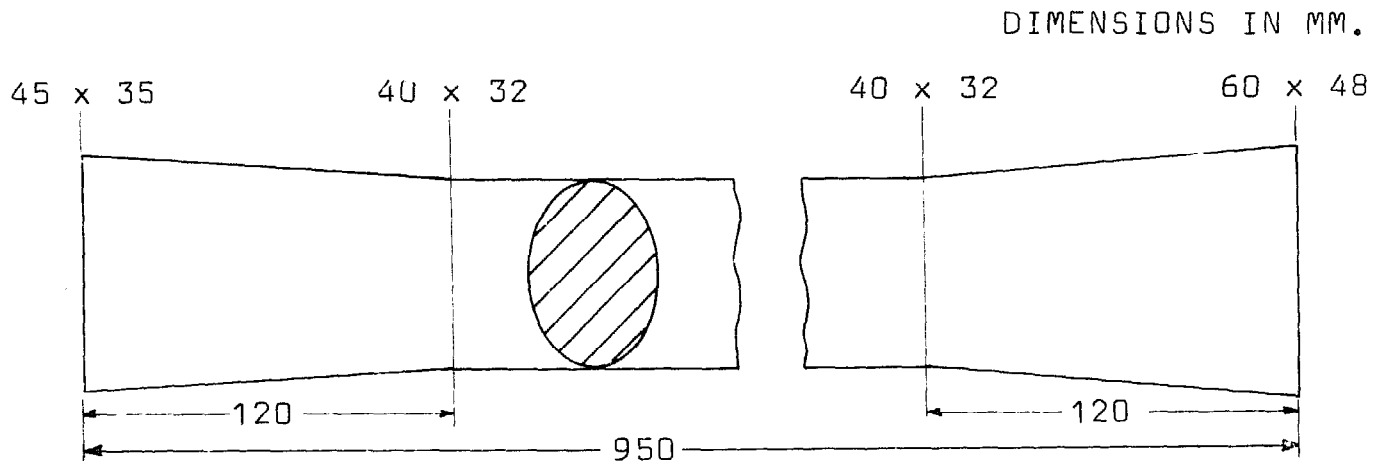



# SPECIFICATION No. 114B — PICK/MATTOCK HANDLE

## *Material*

Hardwood seasoned to not more than 20% moisture content.

## *Testing*

With the larger end clamped over a length of 120mm a load of 45 kilograms shall be gradually applied by suspension at the free end of the handle. There must be no failure, cracking, or permanent set in excess of 25mm on removal of the load.

## *Samples*

Any supplier must submit three samples for dimensional, material, and strength approval, before proceeding with production.

## *Marking*

Handles to be stamped 114B in bold figures.

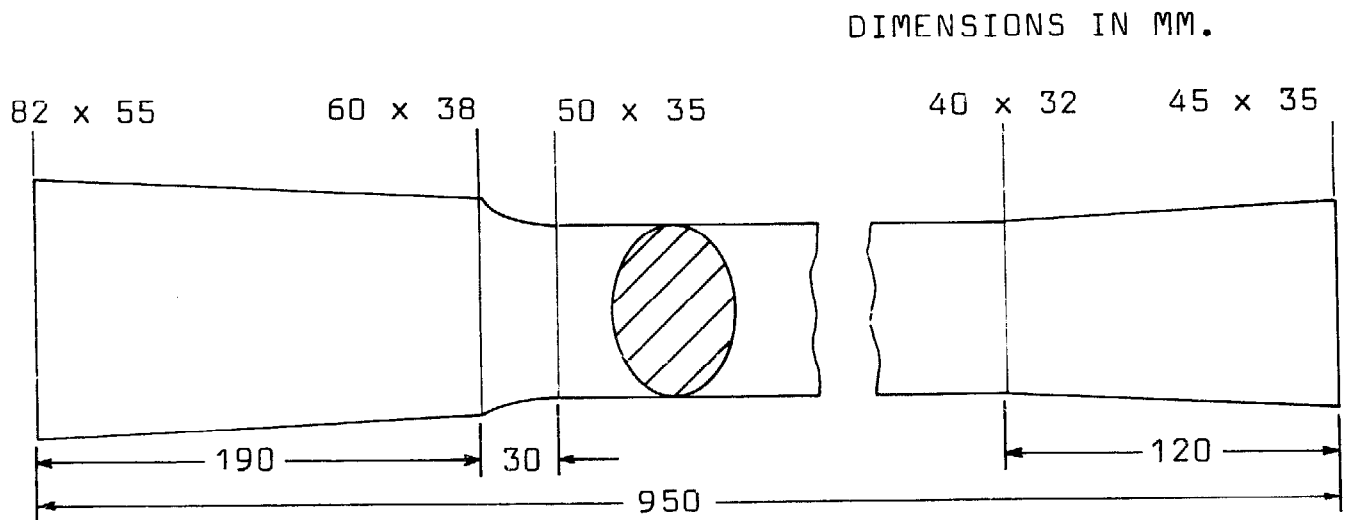

# SPECIFICATION No. 114C — AXE HANDLE

## *Material*

Hardwood seasoned to not more than 20% moisture content.

## *Testing*

With the larger end clamped over a length of 100mm a load of 45 kilograms shall be gradually applied by suspension at the free end of the handle, and maintained for two minutes. There must be no failure, cracking, or permanent set in excess of 25mm on removal of the load.

## *Samples*

Any supplier must submit three samples for dimensional, material, and strength approval, before proceeding with production.

## *Marking*

Handles to be stamped in bold figures 114C at the handgrip end.

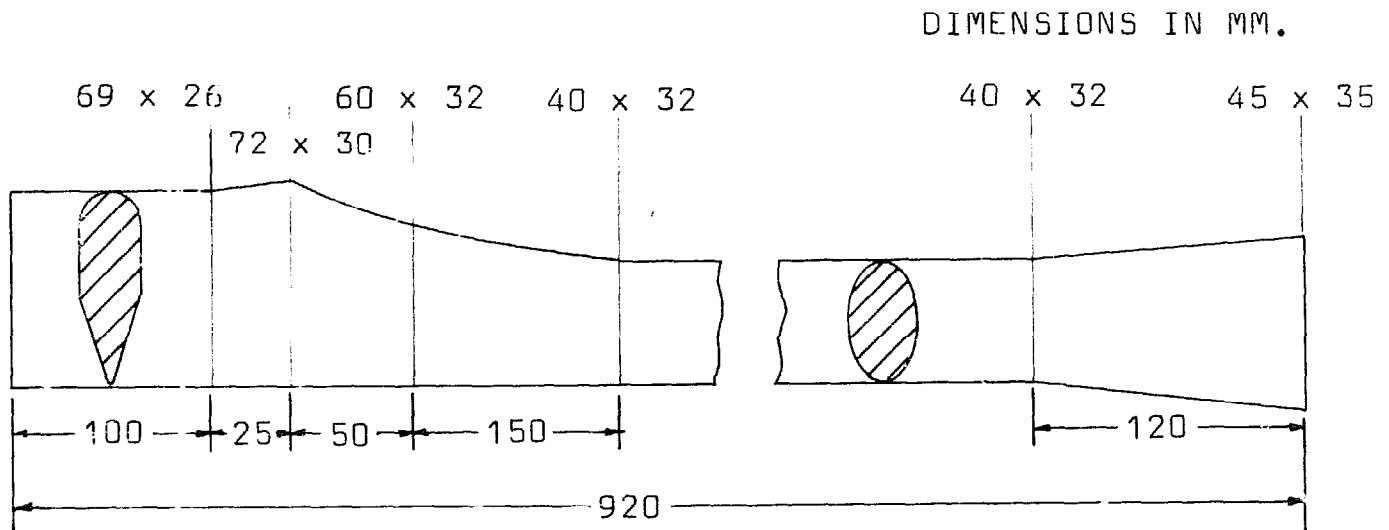

# SPECIFICATION No. 114E — SLEDGEHAMMER HANDLE

## *Material*

Hardwood free from defects seasoned to not more than 20% moisture content.

## *Testing*

With the hammer end clamped over a length of 150mm a load of 40 kilograms shall be gradually applied by suspension at the free end of the handle. There must be no failure, cracking, or permanent set in excess of 10mm on removal of the load.

## *Samples*

Any supplier must submit three samples for dimensional, material, and strength approval, before proceeding with production.

## *Marking*

Handles to be stamped in bold figures 114E at the handgrip end.

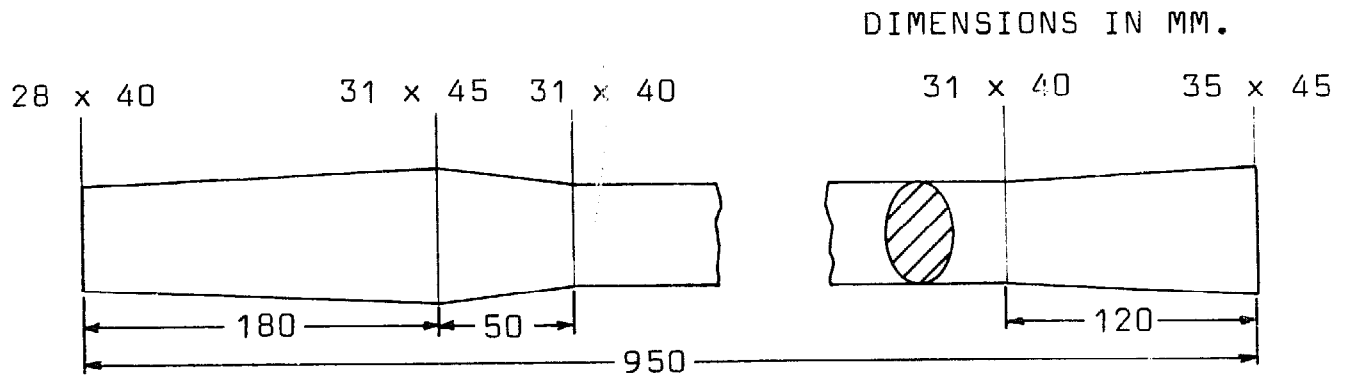

## SPECIFICATION No. 115 — AXE

*Note: For an axe to be effective and retain its edge a high grade chrome manganese steel must be used. It must be forged and heat treated. In general this means that axes have to be imported. The fitting of the handles is a specialised operation.*

### *Weight*

2.3 kilograms (+10%, -5%).

### *Material Specification (Steel)*

Carbon Percent	Manganese Percent	Chromium Percent	Silicon Percent	Phosphorus Percent	Sulphur Percent
0.55 min	0.80 max	0.45 min	0.35 max	0.06 max	0.06 max

### *Heat Treatment and Hardness*

The forging shall be hardened and tempered to produce Rockwell C 25/30 at the eye, increasing to Rockwell C 48/54 within 50mm of the cutting edge.

### *Construction*

The forging must be symmetrical and free from flaws. All fins and flashes must be dressed off. The eye must be smooth internally, uniformly tapered, and must lie central within 0.5mm in the forging. The cutting edge must be ground sharp.

### *Fitting of the Handles*

Handles (to specification No.114C) may be fitted by means of softwood wedges or by chemical adhesive bonding.

### *Testing*

- With a standard hardwood handle fitted and the tool clamped as shown on Figure 2 a load of 45kg shall be gradually applied by suspension at the end of the handle and maintained for two minutes. On removal of the load the tool shall show no signs of damage to the head or loosening of the handle, nor shall there be any permanent set in excess of 25mm measured at the handle end.
- The head/handle joint shall withstand an end load of 500kg without loosening.
- The tool shall withstand a minimum of twenty very heavy blows across the grain of a hardwood without damage to the cutting edge or loosening of the handle.

### *Marking*

The forging shall be clearly and indelibly marked with the following:

- Manufacturer's name and/or trademark.
- The figures 115.
- The nominal weight.

### *Preservative Treatment*

The head shall be bright finished all over and varnished.

SPECIFICATION No.115

DIMENSIONS IN MM.

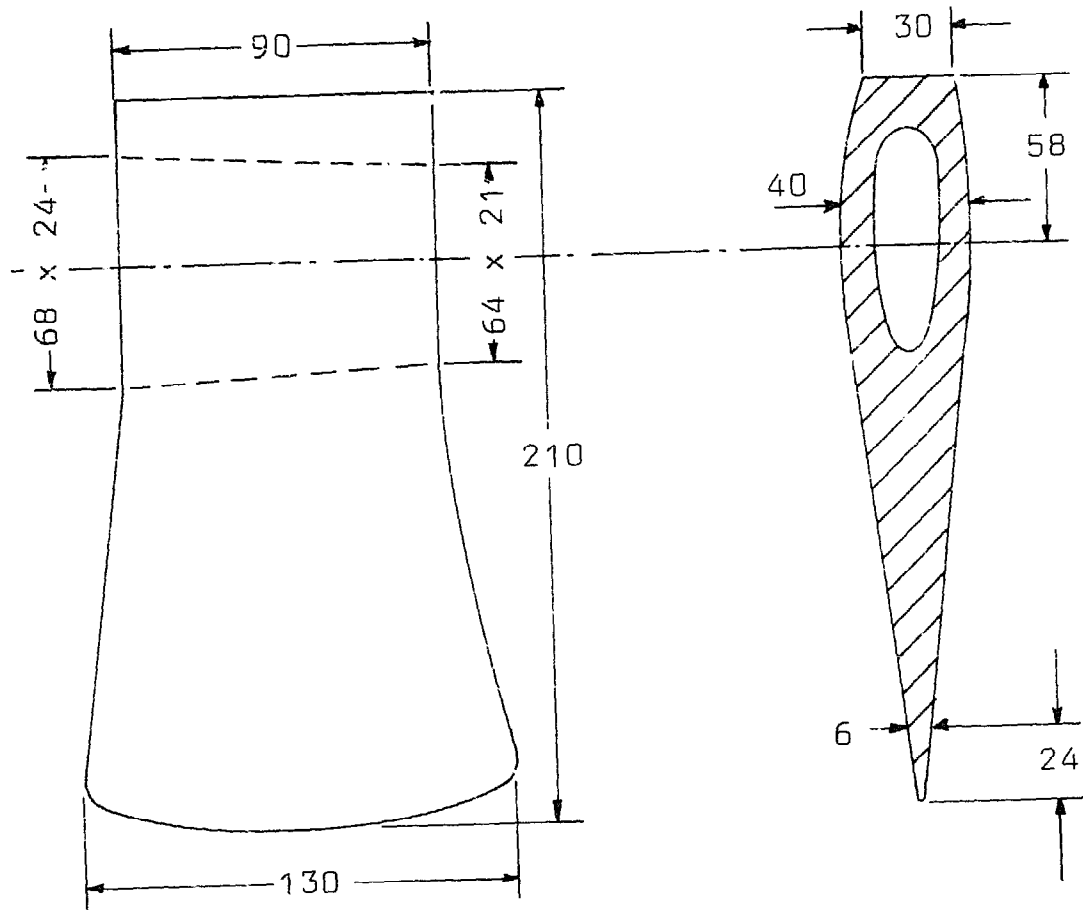

FIGURE 1.

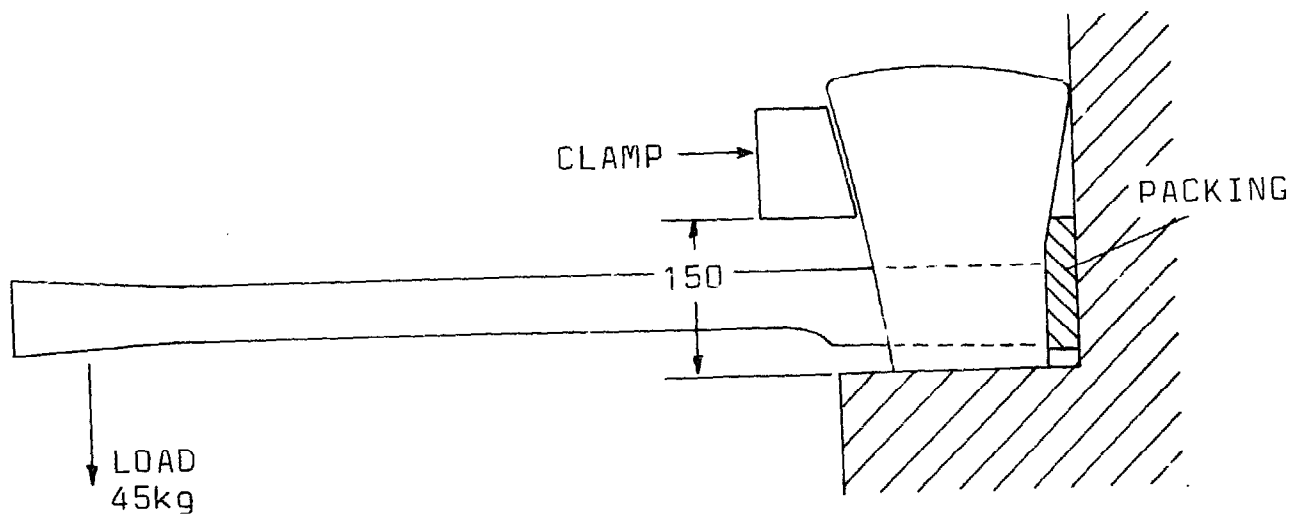

FIGURE 2.

## SPECIFICATION No. 116 — PICKAXE

*Note: It is essential that pickaxes be forged from the medium carbon steel specified and heat-treated as indicated.*

### *Weight*

3.2kg (+10%, -5%).

### *Material Specification (Steel)*

Carbon <i>Percent</i>	Manganese <i>Percent</i>	Phosphorus <i>Percent</i>	Sulphur <i>Percent</i>
0.40/0.50	0.50/0.80	0.05 max	0.05 max

### *Heat Treatment and Hardness*

The forging shall be hardened and tempered to produce Rockwell C 25/30 at the eye, increasing to Rockwell C45/50 within 50mm of the cutting edges.

### *Construction*

The forging must be symmetrical and free from flaws. All fins and flashes must be dressed off. The eye must be smooth internally, uniformly tapered, and must lie centrally in the forging.

The thickness of the blades shall be greatest at the shoulders, decreasing towards the cutting edge and point, which must be ground sharp.

### *Testing*

With a standard hardwood handle fitted and the tool clamped as shown on Figure 2 a load of 45kg shall be gradually applied by suspension at the end of the handle and maintained for two minutes. On removal of the load the tool shall show no signs of damage to the head or loosening of the handle, nor shall there be any permanent set in excess of 25mm measured at the handle end.

The cutting edge and point shall be struck a sharp blow with a bar of mild steel 25mm diameter. No fracture or deformation must occur.

### *Marking*

The forging shall be clearly and indelibly marked with the following:

- a. Manufacturer's name and/or trademark.
- b. The figures 116.
- c. The nominal weight.

### *Preservative Treatment*

The head to be varnished all over.

SPECIFICATION No.116

DIMENSIONS IN MM.

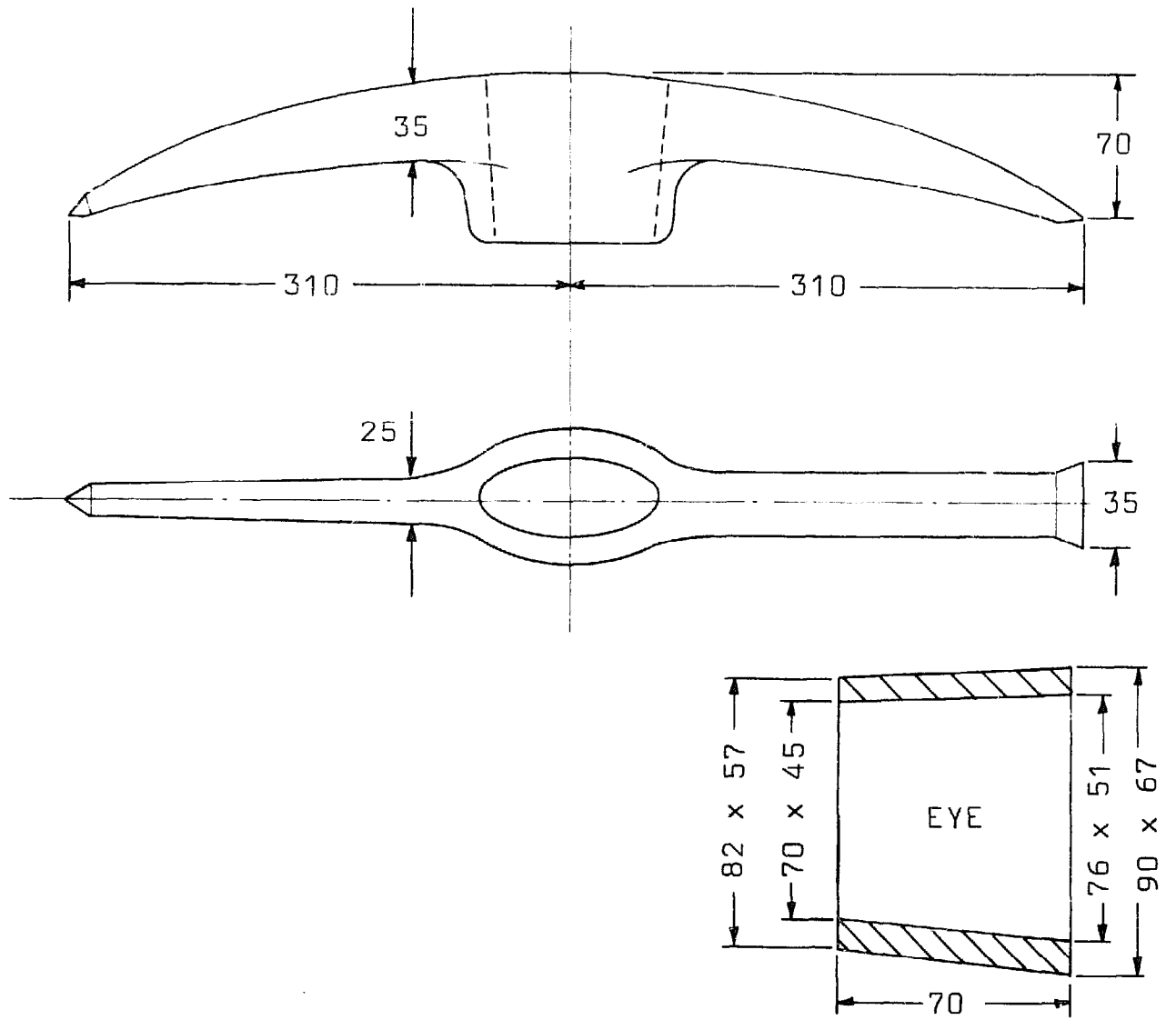

FIGURE 1.

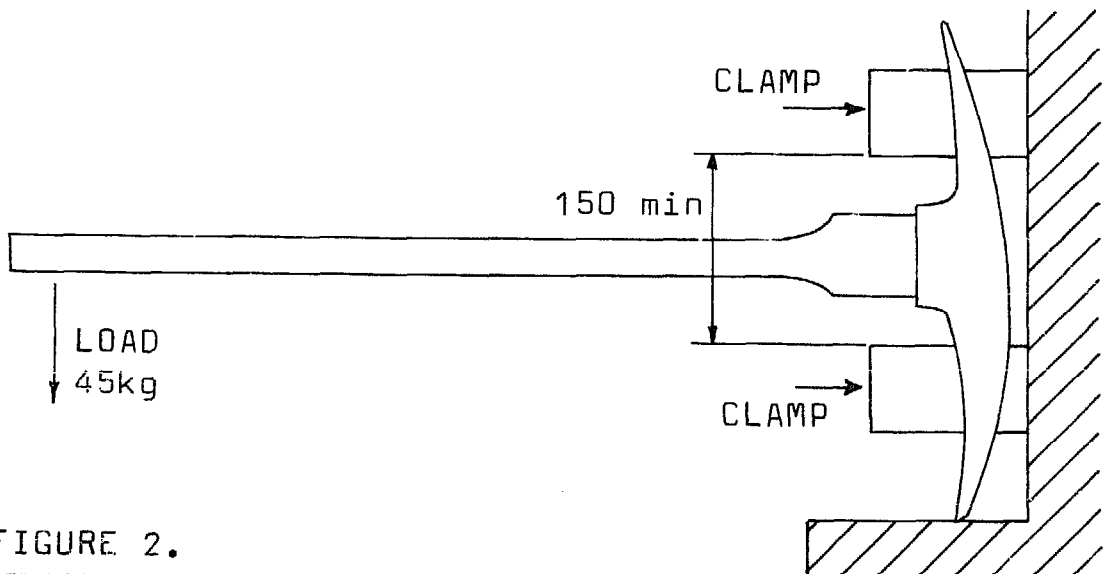

FIGURE 2.

## SPECIFICATION No. 117 — SPREADER

*Note: Garden rakes or up-graded versions of them are not satisfactory under arduous field conditions. This is a simple but appropriate tool.*

### **Weight**

3kg nominal.

### **Material**

Steel. Blade to have carbon content 0.20/0.30 per cent.  
Handle to be hardwood 1500mm long.

### **Construction**

Socket and braces to be welded or riveted to blade.

### **Treatment**

Paint all over with preservative paint.

### **Marking**

The Spreader to be clearly and indelibly marked with:

- a. Manufacturers name and/or trademark.
- b. The figures 117

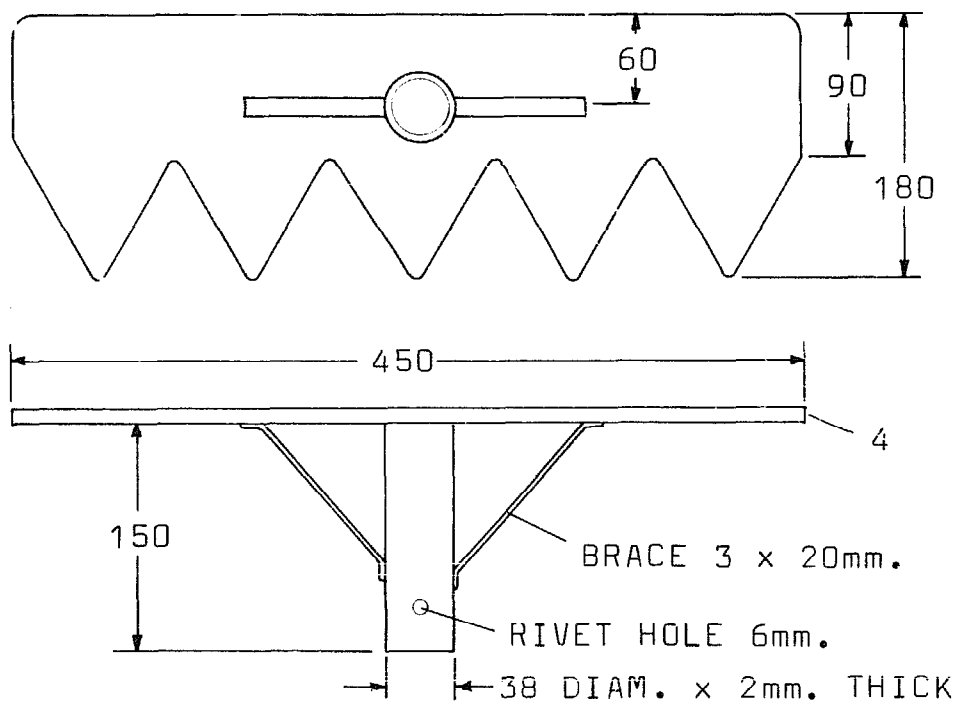

NOTE: HANDLE TO BE HARDWOOD 1500mm. LONG