

**AT** MICROFICHE  
REFERENCE  
LIBRARY

A project of Volunteers in Asia

Appropriate Technology for Water Supply and  
Sanitation. Volume 10: Night-Soil Composting

by: Hillel I. Shuval, Charles G. Gunnerson and  
DeAnne S. Julius

Published by.

The World Bank  
1818 H Street, N.W.  
Washington, DC 20433 USA

Available from:

The World Bank  
Publications Unit  
1818 H Street, N.W.  
Washington, DC 20433 USA

Reproduced by permission of the World Bank.

Reproduction of this microfiche document in any  
form is subject to the same restrictions as those  
of the original document.



Copyright © 1981 by the International Bank for Reconstruction and  
Development/The World Bank

The World Bank enjoys copyright under Protocol 2 of the Universal Copyright Convention. Nevertheless, permission is hereby granted for reproduction of this material, in whole or part, for educational, scientific, or development-related purposes except those involving commercial sale provided that (a) full citation of the source is given and (b) notification in writing is given to the Director of Information and Public Affairs, the World Bank, Washington, D.C. 20433, U.S.A.

VOLUME 10

NIGHT-OIL COMPOSTING

Transportation, Water, and Telecommunications Department

The World Bank

December 1981

## PREFACE

In 1976 the World Bank undertook a research project on appropriate technology for water supply and waste disposal in developing countries. Emphasis was directed toward sanitation and reclamation technologies, particularly as they are affected by water service levels and by ability and willingness to pay on the part of the project beneficiaries. In addition to the technical and economic factors, assessments were made of environmental, public health, institutional, and social constraints. The findings of the World Bank research project and other parallel research activities in the field of low-cost water supply and sanitation are presented in the series of publications entitled Appropriate Technology for Water Supply and Sanitation, of which this report is volume 10. Other volumes in this serie are as follows:

- [vol. 1] - Technical and Economic Options, by John M. Kalbermatten, DeAnne S. Julius, and Charles G. Gunnerson [a condensation of Appropriate Sanitation Alternatives: A Technical and Economic Appraisal, forthcoming from Johns Hopkins University Press]
- [vol. 1a] - A Summary of Technical and Economic Options
- [vol. 2] - A Planner's Guide, by John M. Kalbermatten, DeAnne S. Julius, Charles G. Gunnerson, and D. Duncan Mara [a condensation of Appropriate Sanitation Alternatives: A Planning and Design Manual, forthcoming from Johns Hopkins University Press]
- [vol. 3] - Health Aspects of Excreta and Sullage Management--A State-of-the-Art Review, by Richard G. Feachem, David J. Bradley, Hemda Garelick, and D. Duncan Mara [a condensation of Sanitation and Disease: Health Aspects of Excreta and Wastewater Management, forthcoming from Johns Hopkins University Press]
- [vol. 4] - Low-cost Technology Options for Sanitation--A State-of-the-Art Review and Annotated Bibliography, by Witold Rybczynski, Chongrak Polprasert, and Michael McGarry [available, as a joint publication, from the International Development Research Centre, Ottawa, Ontario, Canada]
- [vol. 5] - Sociocultural Aspects of Water Supply and Excreta Disposal, by Mary Elmendorf and Patricia Buckles
- [vol. 6] - Country Studies in Sanitation Alternatives, by Richard A. Kuhlthau (ed.)

- [vol. 7]        -    Alternative Sanitation Technologies for Urban Areas in Africa, by Richard G. Feachem, D. Duncan Mara, and Kenneth O. Iwugo
- [vol. 8]        -    Seven Case Studies of Rural and Urban Fringe Areas in Latin America, by Mary Elmendorf (ed.)
- [vol. 9]        -    Design of Low-Cost Water Distribution Systems, Section 1 by Donald T. Lauria, Peter J. Kolsky, and Richard N. Middleton; Section 2 by Keith Demke and Donald T. Lauria; and Section 3 by Paul V. Herbert
- [vol. 11]       -    Sanitation Field Manual, by John M. Kalbermatten, DeAnne S. Julius, and Charles G. Gunnerson
- [vol. 12]       -    Low-Cost Water Distribution--A Field Manual, by Charles D. Spangler

The more complete, book versions of volumes 1, 2 and 3 are forthcoming -- under the series title "World Bank Studies in Water Supply and Sanitation" -- from the Johns Hopkins University Press (Baltimore and London).

Additional volumes and occasional papers will be published as ongoing research is completed. With the exception of volume 4, all reports may be obtained from the World Bank's Publications Unit.

DeAnne S. Julius  
 Charles G. Gunnerson  
 Hillel I. Shuval

## ABSTRACT

Among the problems facing those who depend on conservancy or other systems disposing separately grey water and night soil is the lack of a safe, inexpensive treatment method for night soil. In Kyoto, for example, night soil is collected hygienically to the satisfaction of users of the system, only to be diluted at a central collection point for discharge to the sewer system and treatment at a conventional sewage treatment plant. This paper reviews the state of the art on night-soil composting. The paper concludes that aerobic composting of night soil represents a method of treatment ideally suited for developing countries because of its simplicity in operation, limited need for mechanical equipment, low cost and its effectiveness in inactivating pathogens, thus assuring that the compost can be used without causing any public health hazard.

## TABLE OF CONTENTS

|  | <u>Page</u> |
|--|-------------|
| <b>Preface</b>   |             |
| <b>Abstract</b>  |             |
| <b>Summary and Conclusions</b> .....   | i - iv      |
| <b>1. Introduction and Objectives</b> .....  | i           |
| <b>2. Public Health Problems Associated with Pathogenic<br/>    Microorganisms in Night soil and Sewage Sludge Reuse...</b>    | 4           |
| <b>3. The Historical Development of Composting</b> .....   | 13          |
| <b>4. The Principals of the Composting Process</b> .....   | 15          |
| <b>5. Historical Development of Composting Night soil and<br/>    Sewage Sludge</b> .....                                      | 18          |
| <b>6. Modern Developments in Composting Sewage Sludge<br/>    and Night soil</b> .....   | 24          |
| <b>a. Windrow Sludge Compost Plant in<br/>            Los Angeles County Sanitation District</b> .....                         | 24          |
| <b>b. The Beltsville Aerated Rapid Compost (BARC)<br/>            System for Composting Waste Water Sludge</b> .....           | 29          |
| <b>c. Composting Night soil with the BARC System</b> .....   | 40          |
| <b>d. Conclusion</b> .....   | 41          |
| <b>7. Economic Aspects of Night-soil Composting</b> .....  | 42          |
| <b>a. Cost Estimates for Composting Sludge at<br/>            Beltsville (BARC)</b> .....                                      | 42          |
| <b>b. Preliminary Estimates of Costs of Composting<br/>            10 Dry Tons of Night Soil Per Day</b> .....                 | 44          |
| <b>c. Problems of Marketing</b> .....  | 45          |
| <b>8. Research and Pilot Study Needs</b> .....   | 46          |
| <b>a. Characteristics of Night Soil</b> .....  | 46          |
| <b>b. Bulking Materials</b> .....  | 47          |
| <b>c. Environmental Parameters</b> .....   | 47          |
| <b>d. Engineering and Operating Parameters</b> .....   | 47          |
| <b>e. Evaluation of the Final Compost from a<br/>            Microbiological Point of View</b> .....                           | 47          |
| <b>f. Quality of the Compost</b> .....   | 47          |
| <b>9. Bibliography</b> .....   | 50          |
| <b>Appendix I Technological Aspects of the BARC System as Related<br/>            to Composting Night Soil, Dr. E. Epstein</b> |             |
| <b>II Utilization of Compost, Dr. E. Epstein</b>   |             |



### LIST OF TABLES

|  |    |
|--|----|
| 1. Thermal Death Points of Some Common Pathogens and Parasites   | 11 |
| 2. Characteristics of Excreta from Mixed Populations in the U.S. | 19 |
| 3. Capital Costs for BARC System                                 | 43 |
| 4. Operating Requirements for BARC System                        | 43 |
| 5. Total Costs for BARC System                                   | 43 |
| 6. Total Costs for LACSD System                                  | 44 |

### LIST OF FIGURES

|   |    |
|---|----|
| 1. Composting/Drying System   | 26 |
| 2. Bacteria Concentrations Vs. Composting Time  | 28 |
| 3. Schematic Diagram of an Aerated Pile   | 32 |
| 4. Temperatures During Composting of Raw Sludge (May 1975)  | 33 |
| 5. Destruction of Salmonellids, Fecal Coliforms, and Total Coliforms During Composting by the BARC System | 34 |
| 6. Destruction of 'F' Bacterial Virus During Composting   | 35 |
| 7. Materials Balance for the BARC System  | 38 |
| 8. Construction of Extended Aerated Cells for BARC System   | 39 |

## SUMMARY AND CONCLUSIONS

According to the World Health Organization, more than two-thirds of humanity have improper or no facilities for human waste disposal, a situation which leads to a vicious circle of disease and poverty detrimental to social welfare and economic development.

The 1976 HABITAT Conference and the 1977 United Nations World Water Conference set global targets for providing water supply and waste disposal to the whole world's population by 1990. Estimates show that this would involve a cost of \$60 billion for water supply and \$200 billion for waste disposal based on conventional Western engineering practice. If the present rate of investments in this sector are maintained and population growth continues more or less at current rates, it can be estimated that the backlog of over 1 billion people not now provided with water or sanitation service will grow, not decrease. It has also been estimated that most developing economies will be unable to finance water carriage waste disposal systems even if loan funds were available. The World Bank project to study and evaluate appropriate low-cost technology for water supply and waste disposal is aimed at identifying and testing systems capable of providing low-cost water and sanitation services which are both socially and environmentally acceptable at a cost developing countries can afford.

The objective of this report is to evaluate the possibility of developing hygienic and economical means of treating night soil by modern composting so as to allow for the continuation or expansion of direct night-soil collection, disposal and safe reuse systems in many developing countries as an interim or even long-term measure, rather than doing nothing to improve the health of the public while waiting futilely for the day that a water carriage central sewerage system can be afforded.

Night soil use as a fertilizer in agriculture has been practiced in China and other Asian countries for centuries and has been considered by most public health authorities as a serious contributing cause to the high levels of enteric disease and parasitic infestations which debilitate the population. Nevertheless, night soil use as a fertilizer has apparently played a critical role in maintaining vital soil fertility in areas of Asia so intensively farmed for thousands of years. For example, recent reports from China indicate that as a result of a national campaign for night-soil treatment and reuse, one-third of the fertilizer requirements of agriculture in China has been provided by recycled night soil.

The public health problems to be overcome in night-soil treatment and reuse are severe since research has amply demonstrated that night soil and sewage sludge carries high concentrations of the full spectrum of pathogenic bacteria, virus, protozoans and helminths endemic in the community. Many of the pathogenic micro-organisms, helminths in particular, are highly resistant to the environmental conditions prevalent in conventional night soil and sewage sludge digestion and storage and can survive for weeks and even months in the soil and on fertilized crops.

From a survey of the literature on night-soil treatment, it can be clearly concluded that the only fail-safe night-soil method which will assure effective and essentially total pathogen inactivation, including the most resistant helminths such as *Ascaris* eggs and all other bacterial and viral pathogens, is heat treatment to a temperature of 55° - 60°C for several hours. Pathogen inactivation caused by other environmental factors can be effective under certain conditions and for certain pathogens but cannot be considered as reliable as heat inactivation.

To accomplish this direct heating by conventional energy sources is out of the question because of high fuel cost.

The modern day search for economical and effective methods for night-soil treatment by composting which will both assure protection of the public health while providing a continued supply of low-cost soil conditioner was started by Sir Albert Howard in India in the 1930's.

Extensive modern research in composting has demonstrated that the very high temperatures required for heat inactivation of pathogens can be obtained during the active decomposition of organic matter by aerobic thermophilic microorganisms that operate effectively in a temperature range of 45° - 85°C and generate the considerable amounts of excess heat required for destroying the more sensitive pathogens.

Numerous experimental and full-scale composting plants have been developed during the last 30 years in an effort to achieve effective aerobic thermophilic composting of municipal refuse under controlled conditions, many of which could be applied to composting night soil together with other organic wastes. However, most of these plants are based on very expensive high-level technology whose cost has usually been greater than could be afforded even in highly developed economies. In addition, serious operation and maintenance problems have plagued many of the systems.

Two appropriate processes of sewage-sludge composting presently practiced in the United States were selected for study for this report. One is the successful Windrow composting plant of the Los Angeles Sanitation Districts which composts digested vacuum filtered sewage sludge with 23% solids together with old well-composted sludge in open windrows turned at least once a day by huge mobile mechanical composter-shredder machines. Maximum temperatures in the piles above 60°C have been reported for most piles while the minimum temperatures are close to ambient. However, all sludge is presumed to be exposed to 60°C or more for a period of time during the 35-day composting cycle since the piles are turned daily. Laboratory tests show that this process is reasonably effective in inactivating pathogens in the final compost.

The second process reviewed in this report is the Beltsville Aerated Rapid Composting (BARC) system developed at the U.S. Department of Agriculture's Agricultural Research Service Laboratories at Beltsville, Maryland.

This process is based on mixing either raw or digested sewage sludge with wood chips as a bulking material. This reduces moisture content, provides a carbon source needed for more effective composting, and assures the open structure required for the free flow of air in the static compost pile aerated by a 4" (10 cm) perforated pipe under the pile. Air is sucked through the aeration piping system by a simple 1/3-hp blower. The only other equipment required is a front-end loader and a mechanical screening system for wood chip recycling which might not be required for all cases.

Research on the BARC system indicates that extremely high temperatures are achieved consistently in all portions of the fresh sludge mix, which is covered by 30 cm of old compost to provide insulation against heat loss, absorption of odors and water penetration. Maximum temperatures reach 80°-90°C while in no case has the minimum temperature at any point in the pile been lower than 60°C at least for a 5-10-day period. Under these conditions thermal inactivation of most pathogens can be assured. Laboratory assays for pathogens indicate that the system is highly effective in destroying pathogenic bacteria, viruses and helminths. The BARC system has also been used effectively to compost night soil from the National Capital Park Service latrines. Sawdust is added as an additional bulking material to absorb the greater amounts of liquid in raw night soil. The estimated cost of sludge composting with the BARC system is \$38.50/dry ton in a 50 ton/day plant, or about \$8.50 per wet ton of sludge of 22% solids.

The BARC composting system appears to be ideally a night-soil composting system for developing countries, both because of its simplicity in operation and requirement of only limited simple inexpensive mechanical equipment and even more so because of its highly effective and uniform heat inactivation of pathogens which should assure that the final compost is safe from a public health point of view.

It is recommended that a series of research-pilot studies be undertaken in several developing countries to test the system under varying environmental conditions and night soil quality. These studies are essential to provide firm engineering and economic parameters for the development of major projects and to provide field data on the degree of effectiveness of the process in controlling pathogens.

The BARC night-soil composting system if proved effective and economical in field trials may well be a particularly appropriate low-cost technology which can contribute to solving the public health problems associated with continuing or expanding the use of the direct night-soil disposal systems in developing countries unable to afford more expensive water carriage central sewage systems or to those interested in developing appropriate alternative systems more suitable to local cultural and economic conditions.

### Acknowledgments

We would like to thank in particular Dr. Eliot Epstein whose vast experience in composting technology and innovative research have provided essential input for this effort. He played a major role in the preparation of this report. Thanks are also due to Dr. Richard Feachem and Mrs. Hemda Garlik of the Ross Institute-London School of Hygiene and Tropical Medicine for their valuable assistance in locating critical hard to obtain literature on the health aspects of composting. Appreciation is also due to the management and staff of the composting plants visited at Beltsville, Maryland; Windsor, Ontario; and the Los Angeles County Sanitation Districts for their helpful cooperation and for the data and reports provided.

We would also like to thank Dr. Richard Cooper of the School of Public Health, University of California, Berkeley; Dr. Ann Prytulla of the Windsor Regional Public Health Laboratory; Drs. Charles Sorber and Bernard Sagik of the University of Texas at San Antonio; and Dr. Gerald Berg of the Environmental Protection Agency in Cincinnati, Ohio, for providing their valuable published and unpublished research data concerning the health effects of sewage-sludge and night-soil utilization.

The information on commercial sludge composting and marketing supplied by Mr. Phillip of Windsor and Mr. H.C. Kellogg Jr. of Los Angeles was most enlightening and useful.

## 1. Introduction and Objectives

The World Health Organization has estimated that the vast majority of the people of the developing countries constituting more than two-thirds of humanity have improper or no facilities for human waste disposal. This situation leads to a vicious cycle of disease and poverty that is detrimental to social welfare and hampers development (Pineo and Subrahmanyam, 1975).

Both the 1976 HABITAT Conference and the U.N. World Water Conference held in March 1977 in Mar del Plata, Argentina, set global targets for providing water supply and waste disposal to the whole world's population by the year 1990. Such a target is formidable. Since today 60% of the population of the developing countries lack access to water and nearly 70% are without adequate sanitation, which means that there is a current backlog of over one billion persons in need of water and sanitation service. Moreover, if the present levels of investment in this sector are maintained and population growth continues at close to present rates, by 1990 only about half the population in the developing countries will have access to safe water and only 40% will be provided with adequate sanitation. It can be seen from this that, with the present rate of investments and the present costs for water supply and sanitation, it will not even be possible to keep up with the needs of the population growth, let alone clear up the backlog. Estimates indicate that the cost of providing safe water for people in the developing world might reach \$60 billion while the provision of proper waste disposal could cost up to \$200 billion based on current technological approaches.

The most common approach has been to provide the investments required for central water supply systems without providing for adequate waste disposal, thus leading to serious water pollution and public health hazards in many countries. It should be noted here that, based on current conventional Western practice, the provision of central water-carried sewer systems and treatment facilities costs about three times that of providing central water supply.

In recognition of this serious dilemma facing national and international agencies interested in promoting better sanitation in developing countries, the World Bank has initiated a study of appropriate technology for water supply and waste disposal in developing countries, the objective of which is to identify the appropriate technology for providing the urban poor and rural communities with socially and environmentally acceptable water supply and waste disposal services at a cost that they can afford. In addition to the study of the technical and economic feasibility of the various options which are available for water supply and waste disposal in developing countries, special consideration must be given to the health constraints associated with low-cost waste disposal technology. Social

acceptability of such practices is no less important, particularly in the urban areas where the achievement of the Western standard of living has been considered a sine qua non and where water-carried waste disposal has been considered by many as a symbol of social progress worthy of emulating. It is the objective of the World Bank program to collect data on the various technical, economic, environmental, public health, institutional and behavioral factors that relate to the choice of the appropriate waste disposal technology. In both the technical and economic evaluations, an attempt is to be made to broaden the scope of the analysis to include system linkages between the waste disposal technology and its effects on labor and product markets, as well as more complex relationships with other economic sectors, such as agriculture and energy, where reclamation through fertilizer or biogas production is practiced.

The specific objective of this document is to evaluate the possibility of alternative low-cost technology for the disposal of human body wastes, specifically feces and urine, commonly called "night soil," in urban and semi-urban areas where centralized night-soil collection and disposal is practiced. A precondition for the selection of such a technology is to eliminate the public health risks usually associated with this practice in an economically feasible fashion, which should be significantly less expensive than the water-carried waste disposal system.

In the minds of most public health authorities, the bucket system and other night-soil systems practiced in the East and in other developing areas are associated with severe public health problems since, in many of these countries, night soil has been commonly used as a direct fertilizer for garden vegetables consumed raw and has thus led to the transmission of numerous enteric diseases to the population at large and to the agricultural workers directly exposed, as well as to their families living in the immediate vicinity.

Dr. J. W. Scharff, former chief health officer of Singapore, (1940) said in reference to night-soil fertilization: "Though the vegetables thrive, the practice of putting human waste directly on the soil is dangerous to health. The heavy toll of sickness and death from various enteric diseases in China is well-known. Health officers in this country and elsewhere have been brought up, quite rightly, to regard the safe disposal of human excrement as an essential requisite for safeguarding public health. We could justify our action in preventing the use of night soil in agriculture because of the serious risk to health which its use involves.... We have been inclined to regard the installation of a water-carried system as one of the final aims of civilization."

A World Health Organization Expert Committee (WHO, 1974) expressed current feelings on direct reuse of excreta as follows: "Night soil is sometimes used as a fertilizer, in which case it presents great hazards by promoting the transmission of food-borne enteric disease and hookworm."

The above remarks sum up the position of many of those veterans in the public health profession who have tried to grapple with the debilitating health effects associated with improper night-soil fertilization of vegetable crops. Many, if not most, have come to see the water-carriage system as the only alternative, while only limited scientific and engineering effort has been devoted to examine alternative safe and hygienic technologies which may be more suitable both to the economy and to the agricultural needs of a country.

This document will attempt to evaluate the possibility of composting night soil in centralized municipal plants in such a manner as to assure safe and effective heat inactivation of all pathogenic microorganisms while allowing for the reuse of the organic wastes in an economically and socially acceptable manner. It will not cover composting night soil for individual homes or groups of homes. It will also not deal with the possibility of biogas production as an intermediate step in the composting process which produces economically utilizable fuel gas, which is a mixture of methane and carbon dioxide.

At this point it is worthy to note that the Food and Agriculture Organization (FAO) of the U.N. has recently recommended that increased emphasis be given to the conservation and utilization of organic manures as nutrients in agriculture (Food & Agriculture Organization, 1975). The report points out that mineral fertilizers are now in short supply with a strong increase in price within a very short period due to increased costs of energy. Chemical fertilizers are rapidly becoming out of reach for farmers in many developing countries at a time when there is an ever-increasing need to step up food production. The FAO report states, "It is now of the utmost importance and urgency to increase utilization of agricultural and municipal organic wastes as sources of plant nutrients. It is imperative that developing countries should immediately organize and adapt adequate and safe methods for the collection, processing, and utilization of their organic waste materials." The FAO report further recommends, "In large towns, domestic refuse should be collected and processed, if possible, together with sewage sludge in composting plants." It also points out the value of composting with sewage sludge or night soil and states that this practice is compatible with crop fertilization combined with optimum use of inorganic fertilizer, "... provided that adequate treatment and monitoring is used to ensure quality and safeguard health."

It can be seen from the above position taken by FAO as to the needs of increasing organic fertilizers in developing countries that there can be a close tie-in with programs for improving sanitation by hygienically acceptable processes of night-soil composting. Such a technology, if it proves feasible from a public health, economic and social point of view, may provide an attractive interim solution for developing countries which cannot now afford water-carriage waste disposal systems. In some areas such programs may be considered as interim measures postponing investments for considerable periods, while in other areas, depending on the success of the program and its social and economic acceptability, they may become adequate long-term solutions and



avoid the need for developing central sewer systems with all of their economic implications and the environmental hazards associated with them, particularly in relation to water pollution.

## 2. Public Health Problems Associated with Pathogenic Microorganisms in Night-Soil and Sewage Sludge Reuse

An essential prerequisite for the hygienic and safe utilization of night soil after appropriate treatment is the elimination of enteric pathogenic microorganisms that may be present in the original night soil from human sources.

Numerous studies have indicated that the sewage and night soil of a community contain the complete spectrum of enteric pathogenic microorganisms excreted by the community, which is a function of the endemic disease rates prevalent in that community. In addition to pathogenic bacteria, such as the agents of such diseases of typhoid fever and cholera, night soil may contain enteric viruses of such diseases as poliomyelitis, infectious hepatitis and numerous other diseases caused by enteric viruses. In warm, tropical, and subtropical areas of the world, diseases caused by the pathogenic protozoans such as Entamoeba histolytica and Giardia lamblia are usually endemic. Worms or helminths such as Ancylostoma duodenale and Ascaris lumbricoides, and tapeworms such as Taenia saginata are common.

Concentrations of these pathogens in night soil may be quite high. For example, one fertilized female Ascaris worm living in the human intestine produces 200,000 eggs per day (Craig and Faust, 1970) while a female Ancylostome (hookworm) deposits between 25,000 and 35,000 eggs per day. Trichuris trichuira female worms in the human intestine have been estimated to produce 6,000 eggs per day. From the above, it can be seen that the concentration of parasites in night soil or in sewage is a function of the type of parasite and the number of infected persons in the community serving as a source. The prevalence of Ascariasis may exceed 50% in moist, tropical areas of the world. In many other areas a 1% to 10% infection rate is common. Many other protozoan and helminthic diseases show similar patterns of prevalence, with the extremely high rates in moist, tropical, areas, but with broad distribution in other areas at lower rates. It must be assumed that night-soil or sewage sludge contains initially high concentrations of the above pathogens.

Numerous researchers have carried out studies to determine the survival of pathogens in sewage treatment processes, sludge digestion and in the soil. Cram (1943) studied the survival of helminth ova and protozoan cysts in sludge. She was able to demonstrate that Ascaris eggs were found to be extremely resistant to sludge digestion. She reports that for the first 3 months of anaerobic digestion, the viability of the eggs appeared to be little affected. After 6 months, an average of 10% was still viable, and after a year in sludge, eggs were still found which were capable of development. Development of hookworm eggs was more affected by sludge digestion; however, development and hatching of hookworm larvae were demonstrated after sludge digestion for periods up to 64 days at 20°C, and 41 days at 30°C. By comparison, cysts of Entamoeba histolytica appear to be much less resistant.

From observations on 17 lots of sludge, cysts were still viable after 12 days at 20°C, 10 days at 30°C. Ascaris eggs survived long periods of sludge drying; they were viable for as long as 118 days of indoor greenhouse drying and 170 days of outdoor drying. They were resistant to the loss of moisture, viable eggs were found in several sludge cakes with moisture content below 10%. In one lot of sludge, eggs were still viable when its moisture content was 5.8% after 81 days of drying at summer temperatures, which frequently reached 115°F (42°C) in the greenhouse. It was further demonstrated that Ascaris eggs were destroyed in 3 minutes at 103°C.

A study by Wright et al. (1942) demonstrated that the eggs of Ascaris could be recovered from sludge at all stages of the treatment process. Two-thirds of the samples examined from the sludge drying beds were positive. They concluded that the evidence obtained indicated that the use of sewage sludge as fertilizer may serve to disseminate ova of the intestinal parasites studied.

Rudolfs et al. (1950, 1951) carried out an extensive study of the literature on the question of pathogens in sewage sludge and night soil. They concluded the eggs of most pathogenic helminths are fairly resistant in the soil, sludge and in night soil depending on external conditions and that the eggs of the genus Ascaris are the most resistant to environmental conditions. Their conclusion is that vegetables grown in soil contaminated with infected sewage or night soil may be a source of infection. They suggested that although stored night soil or sewage sludge may contain viable eggs for several months, composting for sufficient periods of time at appropriate high temperatures above 55°C can provide effective inactivation. Rudolfs et al (1951) carried out field experiments on the survival of Ascaris eggs on growing tomatoes and lettuce. Results showed that a reduction in the number of eggs took place with time but some eggs remained on the plants and fruits for more than a month. Development of eggs was greatly retarded and completely developed eggs containing motile embryos required for infection were not recovered. They concluded that it appears that the resistance of Ascaris eggs on vegetable surfaces is less than might be expected from considerations of their resistance in soil, feces or night soil. All eggs degenerated after 27 to 35 days and were incapable of development for infection. However, they did state that it must be kept in mind that the field conditions under which these experiments were carried out were those of the dry, hot summer. Whether or not similar results can be obtained under more moist conditions which might prevail in tropical areas of the world where intestinal helminth diseases are more prevalent was open to question by the authors.

Reyes et al. (1963) carried out a study of the effect of aerobic and anaerobic digestion on Ascaris eggs in night soil. They found that at low temperatures, both aerobic and anaerobic digestion tend to preserve Ascaris eggs which subsequently develop normally when removed to a more favorable environment. In the 25°C to 35°C temperature range, both systems resulted in egg destruction attributable to a factor or factors other than heat killing. They hypothesized that oxygen starvation during the period of egg development may be a lethal factor in anaerobic digestion. In neither system is the

destruction of eggs complete at the end point of night-soil stabilization unless temperatures are held at or above 38°C for anaerobic and 45°C for aerobic digestion. Their studies indicated that simple heating of raw night soil at 55°C for 20 minutes should provide a sufficient degree of public health safety. However, offensive odors and poor dewatering characteristics of the undigested material might raise practical objections to this heat treatment method.

Keller (1951) reviewed the literature pertaining to the occurrence and viability of parasitic ova and cysts in sewage sludge. To emphasize the importance of the problem, reference is made to an epidemic of Ascariasis in Darmstadt, Germany, where 80% to 90% of the population had been found to be infected with Ascaris lumbricoides and where the origin of the infestation had been traced to sewage irrigation practice. Undigested raw sludge and sewage had been used to fertilize vegetable fields. The author notes that the extraordinary power of resistance of Ascaris ova to changes in temperatures and moisture concentrations and to chemical influences is due mainly to the complicated structure of the eggshell. The eggshell consists of 5 layers, namely, an outer proteinaceous membrane and 3 layers of chitinous material and an inner lipoidal membrane. The outer albuminous coat is partially coagulated and hardened by certain hostile factors. After reviewing a long series of studies on the thermal death point of Ascaris eggs, the author has come to the conclusion that although Ascaris eggs are extremely resistant to most environmental conditions, including desiccation, there was general agreement that heat treatment over 55°C for a 2-hour period is sufficient to effect 100% destruction of all parasitic ova cysts usually encountered in sewage sludge. Keller did experimental studies with thermophilic digestion of sludge between 53°C and 54°C, and he was able to achieve total inactivation in a 24-hour period at that temperature.

Katayama (1955) carried out experimental heat inactivation of night soil in Kyoto, and succeeded in destroying all parasitic ova, pathogenic bacteria and fly maggots in night soil heated at 60°C. He carried out a field study in Shiga Prefecture and was able to demonstrate a striking decline in the prevalence and incidence rates of Ascaris and hookworm infections in the village practicing heat treatment of night soil as compared with the adjacent village where this was not done.

Hogg (1950) studied the destruction of ova and cysts in digested sludge as a result of sun drying in thin layers of 1" to 6" in depth (2.5 - 15 cm). While sun dried sludge in 1-1/2" layers was found to be free of viable Ascaris eggs, examination of the 3" or 4" layers still showed the presence of viable Ascaris ova, although their numbers were very much reduced. From these results it would appear that sun drying of sludge in relatively thin layers for long periods is effective in destroying Ascaris ova.

Bhaskaran et al. (1956) studied the survival of intestinal parasites in sewage sludge digestion in India. The results of the sludge experiment showed that ova survived digestion under normal air temperature for over 120 days. Thermophilic digestion at 132°F (54°C) results in

complete destruction of the viability of the ova within a few hours. They demonstrated that drying alone is not very useful because it is necessary to dry the sludge to a very low level of moisture for complete destruction of viability which is not feasible in practice. They concluded, however, that thermophilic digestion of sludge would require additional heat from external sources and might not be economical under Indian conditions.

John S. Wiley (1962), one of the pioneers of composting municipal wastes in the United States, surveyed the question of pathogen survival in composting municipal wastes. He hypothesized that pathogen destruction during the composting process may occur primarily as a result of two actions: (a) Thermo kill by sufficiently high temperature and time, and (b) kill by some form of antibiotic action. He felt that in light of recent findings, the latter might be as important as the former. He reports on a study that the Taiwan Institute of Environmental Sanitation conducted in 1956 in which municipal refuse was composted together with night soil. In 20-day windrow composting of ground refuse and night soil with turning and aeration by means of a shredder, temperatures reached 70°C (158°F) persisting for 24 hours and it was concluded from this that all the pathogenic and parasitic organisms in the pile were destroyed. He also reports on a number of studies which indicate inactivation of salmonella organisms at temperatures below thermal inactivation points. He concludes that the destruction of pathogenic organisms must also be due to antagonistic processes, possibly caused by antibiotic inhibitors. He reports on the studies of Knoll of Holland where he was able to demonstrate effective inactivation of pathogens at 50°C producing a final product which was completely acceptable from the general hygienic point of view. The conclusion drawn from Wiley's analysis was that aerobic composting in the thermophilic range achieving temperatures of 55°C for a sufficient period of time could produce a safe product from a public health point of view but that even at lower temperatures many pathogens were destroyed.

Wiley and Westerberg (1969) studied the survival of human pathogens in composted sewage. They evaluated the effectiveness of an aerobic composter in destroying pathogens. Their experiments indicated that Salmonella newport, poliovirus Type I, Ascaris lumbricoides ova, and Candida albican could not survive the composting process. The results of the assay showed that after 43 hours of composting no viable indicator organisms could be detected. The poliovirus Type I was the most sensitive, being inactivated in the first hour, whereas Candida albican was the most resistant, requiring more than 28 hours of composting for inactivation. They concluded that the data from this study indicated that aerobic composting of sewage sludge could destroy the indicator pathogens when a temperature of 60°C to 70°C is maintained for a period of 3 days.

Krige (1964) carried out a survey of pathogenic organisms and helminthic ova in composting sewage sludge in South Africa. He studied various composting plants, some of them using night soil, others using abattoir wastes, and others digested sludge. All of the plants were windrow composting systems, some of which were not turned at all, and others turned as frequently as 5

times in an interval of 7 days. Maximum temperatures recorded ranged from 53°C to 80°C. He concluded that aerobic composting systems were much more effective than anaerobic systems. Poliovirus Type I was inactivated in the aerobic composting plant. He concluded that composts with sewage sludge and night soil under controlled conditions reaching temperatures of 65°C to 70°C were safe from a public health point of view. He emphasized that in static compost heaps or those that are turned infrequently the outside layers never reached the optimum temperatures required for effective inactivation of the pathogens.

Malviya (1964) studied the temperature tolerance of viable ova of Ascaris in composting and concluded that 100% mortality is obtained in a temperature of 50°C when exposed for 60 minutes or more.

A study carried out by the Szechwan Research Institute of Parasitic Diseases in China (1964) indicates that only partial removal of parasitic eggs of Ascaris and hookworms is obtained by detention in the digestion tanks or septic tanks. They report that a 97% reduction in hookworm larvae and 94% reduction in other parasitic ova was achieved. They concluded that such tanks, although they do not provide complete inactivation of parasitic ova, do contribute to reducing the health risks associated with the use of night soil in agriculture.

McGarry (1976) in his review of the use of human excreta in Chinese agriculture reports on a very successful program of the Chinese in the use of night soil in agriculture which has supplied, according to the estimates of the Chinese government, one-third of the nutrients in fertilizer utilized in that country. They introduced a number of relatively simple ways of treating night soil either by detaining it in tanks for a few weeks prior to spreading or by composting. The efficacy of some of these treatment processes has not been fully reported upon. According to McGarry, methods of treating night soil prior to its application have been developed and are in widespread use. He reports that at the time of the revolution use of excreta as fertilizer aided the spread of disease in China. The rural population of nearly 400 million was heavily infected with worm diseases with 40% to 90% of those examined harboring Ascaris worms. Other diseases of importance were Typhoid, Salmonellosis, Shigellosis, Cholera, Hookworm and Schistosomiasis.

A massive program of hygiene and sanitation based on health education is reported to have reduced disease rates in the rural areas. It is McGarry's contention that the combined efforts of health education and rural medical schemes together with the night-soil treatment introduced led to this improvement and that the benefits of night-soil reuse as fertilizer far outweighed any disadvantages from the health point of view. Ch'an et al (1959) in their report of the achievements in the fight against parasitic diseases in China state that the use of human excreta as a fertilizer plays an important role in the spread of parasitic diseases. They report that the method of storing feces with urine in water as practiced in some countries was not found as effective as storing with urine alone. They feel that this is

because the ovicidal action is mainly caused by the ammonia liberated from the urine. They report that in the summer it required 2 weeks and in the winter 1 month to kill most of the ova in the mixture. Compost piles covered by packed clay and partially aerated by vent holes formed by bamboo poles as practiced in China have been reported to achieve inside temperatures in the summer over 56°C required to kill parasitic eggs. They feel that the success of night-soil control program has been proved by the reduction in the rates of enteric disease such as dysentery. Undoubtedly, the progress made in public health in China is due to the combined effect of their intensive programs of improved medical care and personal hygiene as well as night-soil treatment, which have become national programs of mass activity with wide popular support.

Moore et al. (1977) have assessed the risk of virus survival in sludge disposed of on land. Their studies show that the level of infection of viruses in sludge is high and the disposal of the sludge to the land may become a public health problem of concern. They report that sludge digestion may achieve a 3 or 4 log cycle reduction in the virus concentration. They have also shown that poliovirus could survive in the soil for over 134 days at 4°C and could still be detected at 134 days at 20°C. However, when the soil temperature was 30°C no virus could be detected after 49 days. They state that viruses applied to the soil can move through soil systems and lead to the pollution of ground water or crops. Cliver (1976) studied the problem of viruses in sewage sludge and reports that viruses have a strong tendency to settle with the sludge during sewage treatment, and that some digestion processes do not inactivate all of the viruses present in the sludge. The report of the Sandia Laboratories (1976) indicates that moisture content plays an important role on the inactivation rates of enteric viruses in sludge during digestion and drying. Gradual reduction of recoverable infectivity occurred with poliovirus as the solids content of the sludge was increased up to about 65%. Further reduction in solids content to 83% caused an additional reduction of virus greater than 3-log cycles. Similar results were found with coxsackie virus and reovirus which suggest that this behavior may be a general property of enteric viruses. Thus, dewatering sludge by evaporation may be an efficient way of inactivating enteric viruses. Smith and Selena (1976) report from the Los Angeles sludge composting operation in windrows that with temperatures between 55°C and 60°C they were able to achieve results that yielded negative findings for viruses, parasitic ova, and salmonella in the vast majority of final compost samples. Total coliform concentrations in the final compost have not been uniformly below 1 MPN per gram as specified by the California State Health Department.

Experiments were also carried out in the Los Angeles area on the application of liquid sludges directly to agricultural lands (Yanko et al., 1976). In these studies the application of liquid sludges to soil resulted in extremely high concentrations of indicator bacteria and salmonella. Salmonella population appeared to increase during the first few weeks in the soil. Viable Ascaris ova were also detected. After the growing season, all soil populations appeared to stabilize. No apparent microbial hazard from the organisms tested during this study was associated with the field

crops grown in either compost or liquid sludge amended soils or with the vegetables which were grown in the compost-treated soils. This study indicates that even pathogens remaining in sewage sludge or compost seem to disappear rapidly in the soil. Microbial hazards to crops grown appear to be limited, according to the authors.

Epstein et al. (1977) show effective inactivation of  $F_2$  bacteriophage during BARC composting at Beltsville with minimum temperatures above  $60^{\circ}\text{C}$  at all times for a 5-10 day period. Total coliforms, fecal coliforms and salmonella are undetectable after 10 days of composting while less effective inactivation of pathogens was found in windrow composting (Burge et al., 1973, 1974). Studies have indicated that elevated temperatures in sanitary landfills between  $55^{\circ}$ - $60^{\circ}\text{C}$  are effective in inactivating poliovirus. Studies by Dr. Robert Cooper at the University of California at Berkeley (unpublished) indicate that composting of sewage sludge together with refuse led to the inactivation of poliovirus in a 3-day period. Bacteriophage concentrations in the same compost heap dropped 6-log cycles in a 35-day period. The temperature in the hottest part of the compost pile reached  $60^{\circ}\text{C}$  for a 4-day period during the first 25 days, then dropped of  $45^{\circ}\text{C}$  at 30 days, and  $20^{\circ}\text{C}$  at 35 days. The pile was turned 9 times in a 25-day period. This can be considered quasi-aerobic windrow composting and, undoubtedly, the surface of the pile remained at close to ambient temperature.

Cotaas (1953) summarized the available information on the thermal inactivation of pathogens (see Table 1).

Table 1

THERMAL DEATH POINTS OF SOME COMMON PATHOGENS AND PARASITES  
(From Gotaas, 1953)

---

| Organism  |
|---|
| <u>Salmonella typhosa</u> : No growth beyond 46°C; death within thirty minutes at 55°C to 60°C.                                   |
| <u>Salmonella spp.</u> : Death within one hour at 55°C; death within 15 minutes to 20 minutes at 60°C.                            |
| <u>Shigella spp.</u> : Death within one hour at 55°C.   |
| <u>Escherichia coli</u> : Most die within one hour at 55°C, and within 15 days to 20 minutes at 60°C.                             |
| <u>Endamoeba histolytica</u> cysts: Thermal death point is 68°C.  |
| <u>Taenia saganita</u> : Death within five minutes at 71°C.   |
| <u>Trichinella spiralis</u> larvae: Infectivity reduced as a result of one hour exposure at 50°C; thermal death point is 62-72°C. |
| <u>Necator americanus</u> : death within 50 minutes at 45°C.  |
| <u>Brucella abortus</u> or <u>suis</u> : Death within three minutes at 61°C.  |
| <u>Micrococcus pyogenes</u> var. <u>aureus</u> : Death within 10 minutes at 50°C.   |
| <u>Streptococcus pyogenes</u> : Death within 10 minutes at 54°C.  |
| <u>Mycobacterium tuberculosis</u> var. <u>hominis</u> : Death within 15 to 20 minutes at 66°C, or momentary heating at 67 C.      |
| <u>Corynebacterium diptheriae</u> : Death within 45 minutes at 55°C.  |



## Conclusions

From the above studies carried out over the last 35 years, it is quite apparent that night soil and sewage sludge can carry very high concentrations of pathogenic bacteria, viruses and parasites, depending on the endemic disease rates in the community. Most of these pathogens are not effectively inactivated by conventional sewage treatment process and most of them are highly concentrated in the sludge. Neither are these pathogens inactivated entirely during conventional sludge digestion and drying processes although their numbers may be reduced. The concentration of such pathogens in fresh night soil is even greater than that found in sewage sludge. It has been amply demonstrated that viruses, bacteria, and helminth ova can persist for extended periods of weeks and months, and sometimes years, in the soil, particularly in moist climates. There appears to be presumptive epidemiological evidence from many tropical and subtropical areas that indiscriminate use of fresh night soil in fertilizing vegetables and salad crops usually eaten raw has led to extensive disease transmission both to the consumers of such crops and to the farmers themselves. Some researchers have suggested, however, that environmental factors are often effective in inactivating the pathogens in night soil so used, thus reducing the risk significantly.

Although a number of factors are active in inactivating pathogens of various types in the environment including biological activity, desiccation, and other antagonistic environmental factors, it is abundantly apparent from all the reports presented that the only fail-safe method of inactivating pathogens in night soil or sewage sludge is heat treatment  $55^{\circ}\text{C}$  for an extended period of time. In those processes where only part of the compost pile reaches this temperature, it is apparent that there appears to be a regrowth of enteric bacteria, including salmonella organisms, in the cooler exterior portions of the pile after it is turned, so that a population of pathogenic salmonella organisms can continue to survive in a windrow type of operation which is turned infrequently. Daily turnings and thorough mixing may be able to overcome this problem.

The most effective method to assure total destruction of the pathogens of public health concern in night soil and sewage sludge is a method of direct heating or of composting which assures a uniform temperature above  $60^{\circ}\text{C}$  in all portions of the compost pile at the same time over an extended period of days. Direct heating of night soil to destroy all pathogens has been used in Japan and Singapore but the final product is still not suitable for direct reuse and would require further treatment while, with current costs of energy, direct heating is not feasible from an economic point of view.

Since the reuse of night soil would require some form of treatment to reduce its moisture content and to improve its soil conditioning characteristics, the remainder of this document will be devoted to an evaluation of night-soil composting. The aim is to determine whether techniques and systems are now available to meet the strictest public health goals of assuring an essentially pathogen-free material which will also provide a

useful, socially acceptable and economically feasible procedure for returning organic materials to the soil to improve its structure and increase its fertility.

### 3. The Historical Development of Composting

Composting in its simple and traditional form has been practiced by farmers and gardeners throughout the world for many centuries. Vegetable matter and animal manures are placed in piles in some available open space or thrown into pits and allowed to ferment through natural microbial action until ready for application to the soil. This process usually requires six months to a year and traditionally involves no control except perhaps covering the mass with soil or turning it once or twice during the year (Cotaas, 1953). Composting of night soil together with other vegetable and animal manure wastes has been practiced in China through the centuries and has been considered a vital aspect of maintaining the soil fertility of that country. It has been reported that the Chinese practice of composting with crop residues and human wastes has been the key in supporting high population densities and in maintaining soil fertility and structure over some 4,000 years (McGarry, 1976b).

The arousal of interest in composting in the West probably stemmed from an extended visit to China, Japan and Korea in 1909 by Professor F. H. King of the U.S. Department of Agriculture (King, 1927). It has been reported that his text was read by Sir Albert Howard, a British economic botanist employed by the Indian government, who was able to put King's observations on composting in China to test in India. After several years of experimentation, Howard established that his Indore method of composting gave optimal results in terms of the vegetable and animal waste, supply of labor and the climate conditions available in his district (Howard, 1935). Howard's system was essentially based on building piles of vegetable material and animal manure and wood ashes which were heaped and turned after 16, 30 and 60 days with intermittent watering. The finished compost was removed to the fields after 90 days. His experiments showed very favorable results from an agricultural point of view and was rapidly taken up by plantations and farms in many parts of the world. The system was based on the use of hand labor which was particularly suited to the economic situation existing in India at time.

Modifications of the original system used closed or open cells. Various attempts were made to introduce air into the piles so as to avoid the escape of foul odors associated with the breakdown of organic matter under anaerobic conditions. In 1931 Jean Bordas (Gotaas, 1953) is reported to have made one of the first attempts to completely eliminate the anaerobic stage by introducing forced air into a fermentation silo. The silo was divided by a grate into an upper and lower section and air was introduced along the walls and through a central pipe.

With the growing interest in composting of municipal refuse for urban areas, various mechanical devices for materials handling, grinding

of refuse and aeration of the refuse were developed. Among them the Dano process, developed in Denmark, and the VAM practiced in Holland. In the Dano process, refuse is fed into a large, slowly rotating horizontal cylinder where it is homogenized, aerated and broken down to some extent during a 3- to 5-day storage period. After removal of ferrous metals by a magnetic separator, it then passes to a grinding and homogenizing machine where granulation is accomplished. The ground material is then composted in open piles 5- or 6-feet high which often become anaerobic. The VAM process, practiced in Holland since 1932, is essentially an adaptation of the Indore process to the composting of municipal waste on a large scale. In some such installations, the refuse is first ground in a special mill which is a device like a rimless wheel with spokes at the hub rotating above a roughened horizontal plate. The ground refuse is then placed in open piles and sprinkled and turned from time to time during the composting period. During most of the composting period the piles are anaerobic and have been known to be a source of nuisances.

Since those early developments in mechanical composting, numerous proprietary composting systems have been developed including multi-staged silos and various systems which attempted to achieve aerobic conditions through forced aeration with a static pile. In addition, in recent years, special devices have been developed for turning and shredding compost windrows. Especially designed mechanical equipment passes along the windrow as it processes the refuse. It is beyond the scope of this report to review all such systems developed in the last 30 years.

During the 1950's, basic studies and research on composting for municipal waste treatment were conducted at the University of California under the direction of Professor Harold (Gotaas, 1953). He later published a widely known and comprehensive monograph entitled "Composting and Sanitary Disposal and Reclamation of Organic Wastes," under the sponsorship of the World Health Organization (Gotaas, 1956).

Composting of municipal refuse developed rapidly in Europe with some 200 plants reported to be in operation at the present time. A number of mechanical composting projects were initiated in the U.S. using high technology equipment (Office of Solid Waste Management, 1971) (Stone et al. 1975). Some of these plants have been plagued with technological problems, equipment failures and odor nuisances and have come under severe criticisms due to high costs and poor operational records.

Another key factor in limiting the success of composting processes in the U.S., as well as to a certain extent in Europe, has been the limited market for the sale of municipal composts due to the low price and easy application of inorganic fertilizer which has been heavily promoted by agricultural authorities as the quickest and most certain way of producing high yields in agriculture. Another problem that plagued the sale of municipal compost was poor quality since it often contained many splinters of broken glass, metals and plastics which could not be successfully removed and led to serious problems in its agricultural use. Another problem has arisen

when municipalities attempted to charge the total refuse or sludge disposal onto the product cost thus outpricing the market.

The EPA summarized its position on the composting of municipal refuse in the U.S. in the following statement: "Economically composting does not compete on a net cost-per-ton-processed basis with either landfilling or incineration of municipal refuse. Evidence gathered from many sources indicates that the rather high cost of producing compost is not sufficiently offset by income from its sale to permit the process to compete economically with other acceptable systems. The most optimistic estimate of an income-producing market for compost suggests that only a small fraction of the waste generated by a unit of population could be marketed as compost. Many feel that if the techniques of landfilling and incineration, however, fail to keep pace with increasingly stringent environmental protection criteria or manage to do so but become more and more expensive reflecting all the costs associated with their process, composting may become a relatively more important tool in resource systems management that could accommodate various proportions of municipal, industrial and agricultural waste."

#### 4. The Principles of the Composting Process

The principles of composting have been well described by a number of authors (Gotaas, 1953, 1956; Gray et al., 1971; and others). It shall be summarized here briefly for purposes of completeness, based mainly on the works of Gotaas (1956).

Composting can be defined as the biochemical degradation of organic materials to a humus-like substance by natural microbiological processes constantly carried out in nature. Simple forms of composting long practiced by farmers throughout the world involves anaerobic decomposition over a long period of time. Anaerobic decomposition of organic matter is, however, often associated with the formation of foul-smelling gases such as indol, skatol, and mercaptans and usually proceeds at a relatively low temperature close to ambient, with microorganisms operating in the mesophilic range between the temperatures of 8° and 45°C. Aerobic composting requires sufficient amounts of atmospheric oxygen and produces none of the objectionable features associated with anaerobic decomposition. Both mesophilic and thermophilic organisms involved in composting are widely distributed in nature and are to a great degree indigenous in all types of refuse and sewage sludge. Research studies have shown that no supplemental inoculants are required for normal composting (Gotaas, 1956).

Because it is a biological process, environmental factors influencing the activities of the organisms determine the speed and the course of the composting cycles. Most important are particle size of the material, moisture content, aeration, hydrogen ion concentration, temperature and initial carbon-nitrogen ratio. The particle size is important since the more minute the particle the more susceptible it is to bacterial or fungal attack because of the greater surface area exposed (Gotaas, 1956).

An optimum moisture content of the mixed refuse is essential to good composting since all living organisms require moisture for their existence. Water is an important constituent of cell protoplasm and, in addition, it dissolves nutrients rendering them available for utilization by the organisms. If the moisture content drops below 20% the microbial processes are severely inhibited and slowed down while if the moisture content increases above 60%, passage of air becomes difficult and anaerobic processes set in. For aerobic composting, a freely available supply of oxygen is essential in order for the aerobic bacteria to carry on their activities. An aerobic process is more efficient than an anaerobic one in the decomposition of organic matter. In fact, organic material cannot be stabilized completely under anaerobic conditions because further oxidation is always possible by aerobic organisms in the presence of atmospheric oxygen. Therefore, the control of moisture is a critical factor in the operation of composting processes.

Microorganisms are sensitive to the temperature changes in the compost heap. Mesophilic forms exist in temperatures of 8° to 45°C, activity diminishing at either extreme. Thermophilic organisms grow and thrive in temperatures higher than 45°C although only a few groups carry on any activity at temperatures above 65°C. However, significant biological activity in compost heaps can continue in the range between 65° and 90°C. Obtaining higher temperatures in the thermophilic range is very desirable from the hygienic point of view since as noted earlier most pathogenic microorganisms are inactivated above temperatures of 55°C with most others inactivated at temperature above 60°C.

The activities of living organisms are enhanced by proper nutrition. Important in the matter of nutrition is the supply of available carbon to serve as an energy source, and of nitrogen for the building of protoplasm. Energy requirements being high, more carbon than nitrogen is needed; however, there is a limit in the excess of carbon over nitrogen beyond which organic activity diminishes. The proportion of carbon to nitrogen is termed the C/N ratio. It is felt that an optimal C/N ratio for efficient and effective composting is about 25 to 30, while stabilized compost or humus are characterized by a C/N ratio ranging from 10 to 20, depending on the original material from which the humus was formed and the degree of decomposition.

An optimal combination of all the above factors including particle size, C/N ratio, pH, aeration and temperature is essential for effective composting. Numerous researchers have demonstrated that with proper combination of these factors under aerobic conditions, compost heaps can reach the thermophilic range and continue at high temperatures above 60°C for 5- to 10-day periods which would be adequate to inactivate all forms of pathogens. Therefore, aerobic, thermophilic composting can provide a high degree of safety from the health point of view as far as the destruction of pathogens is concerned, and produces a stable well-composted material which has been shown to be a useful and effective soil conditioner.

Since the maintenance of aerobic conditions is an essential pre-condition for effective thermophilic composting, considerable efforts have been devoted to developing technologies to assure adequate air supply. It is beyond the scope of this report to describe all the equipment and processes that have been developed but they can all essentially be divided into the following groups:

(a) Windrows. In the original Indore process and similar processes, the windrow form of composting was essentially anaerobic during most of the period except the period immediately after turning the pile. In the course of years, equipment has been developed to turn the pile mechanically so that the windrows could be turned daily or even more frequently. As currently practiced by the County Sanitation Districts of Los Angeles (1975), mechanical equipment is used to turn the piles daily and, on occasion, two or three times a day, maintaining aerobic conditions and thermophilic composting during the total composting period of 20 to 35 days. Another way of assuring aeration in the windrow system is through forced aeration from the bottom of the compost pile. Most of the early attempts in aerating compost piles in this manner were only partially successful. Recently Epstein et al. (1976) developed a forced aeration system for composting wastewater sludge with wood chips at the Agricultural Environmental Quality Institute of the U.S. Department of Agriculture in Beltsville, Maryland. The system, called the Beltsville Aerated Rapid Composting (BARC) System, will be described in detail later in this report and is based on placing 4-inch (10 cm) plastic perforated drainage pipes in a loop under a static pile of sludge mixed with wood chips and other bulking materials, covered with a layer of well-composted material. Air is drawn through the piping system with a small 1/3-hp blower. This system has been shown to effectively aerate the pile in such a manner as to assure aerobic thermophilic composting during a 21-day period.

(b) Closed Composting Systems. Various manufacturers have marketed enclosed composting systems which involve either a rotating drum or multi-stage tower silos or other complicated mechanical devices which are designed to assure thorough mixing and aeration of the compost. Some of these systems have demonstrated effective aeration and thermophilic composting but they are usually associated with extremely high-cost and complex operation and maintenance problems.

Although composting in windrows occasionally turned as proposed by Sir Albert Howard does not assure aerobic conditions for extended periods, several reports indicate that aerobic thermophilic fermentation does take place for part of the period achieving temperatures in excess of 55°C for sufficient periods of time to provide effective inactivation to that portion of the pathogenic microorganisms near the center of the pile exposed to the high thermophilic temperatures. If such piles are turned a number of times in the course of the composting period, there is a reasonable chance that a significant portion of the pathogens will be inactivated although it is difficult to assure total destruction of them all since the outer layers of the compost heap are maintained close to the ambient temperature. This does not assure thermal inactivation. There is some evidence, however, that other

biological factors may contribute to the inactivation of some of the pathogenic microorganisms, thus reducing the risk of their survival even if thermal inactivation temperatures are not achieved in all portions of the compost pile.

It is the purpose of this report to determine whether effective aerobic thermophilic composting of night soil is obtainable under conditions of low capital investment and minimal equipment, operation, and maintenance that are essential for developing countries.

## 5. Historical Development of Composting of Night Soil and Sewage Sludge

The Chinese have composted night soil for centuries together with agricultural waste in anaerobic piles but little scientific data are available on the process as practiced in antiquity.

Night soil is a term frequently used to describe human excreta with or without urine which is collected in buckets from the home daily or at larger intervals if it is stored in vaults. This form of excreta collection and disposal is practiced in large areas of Africa and Asia including industrialized countries such as Japan.

Little scientific data is available on the composition and quantities of night soil produced in various parts of the world but the quantities and composition vary according to local customs and culture as well as based on the dietary habits. Mann (1976) reports on the average daily output of waste per person based on his experience in Africa. He estimates 400 grams wet weight per day of feces and 1,200 grams of urine per day, giving a total of 1,600 grams. He states that there is considerable variation between communities based on diet, water consumption, general health and the amount and nature of the personal cleaning materials used. Moslem countries, for example, use water for anal cleaning purposes. McGarry (1976) reports that a volume of about 2 liters is estimated for China since this includes a certain amount of water used for flushing purposes. He also reports that the nitrogen content of feces is 5% to 7% and that of urine is 18%. Kubo and Sigiki (1977) report the following analytical results for crude night soil in Japan:

|                                   |            |
|-----------------------------------|------------|
| BOD                               | 12,000 ppm |
| COD                               | 3,000 ppm  |
| volatile acid<br>(as acetic acid) | 6,000 ppm  |
| NH <sub>4</sub> (as N)            | 4,500 ppm  |
| PO <sub>4</sub> (as P)            | 1,000 ppm  |
| Chlorides (as Cl <sub>1</sub> -)  | 5,230 ppm  |
| Albumenoid nitrogen<br>(as N)     | 780 ppm    |
| pH                                | 7 to 9     |

Snell (1943) evaluated the daily production of excreta by the mixed population of the United States in 1930 as follows:

Table 2

CHARACTERISTICS OF EXCRETA FROM MIXED POPULATIONS IN THE U.S.A., 1930 (SNELL, 1943)

| <u>Matter</u>        | <u>Weight per day (grams)</u> | <u>Total Residue %</u> | <u>Organic Matter %</u> | <u>Nitrogen %</u> | <u>Phosphoric Acid %</u> | <u>Potassium %</u> |
|----------------------|-------------------------------|------------------------|-------------------------|-------------------|--------------------------|--------------------|
| Feces                | 86                            | 22.8                   | 19.8                    | 1.00              | 1.10                     | .25                |
| Urine                | <u>1,055</u>                  | <u>3.7</u>             | <u>2.4</u>              | <u>.60</u>        | <u>.17</u>               | <u>.20</u>         |
| <b>Total Excreta</b> | 1,141                         | 5.15                   | 3.7                     | .63               | .24                      | .20                |

In comparison, the author cites China which is believed to produce about 80% of the above weights with a nitrogen content of about 0.4% owing to a lower body weight and food with less protein. Snell experimented with the composting of feces and urine. He reports that feces seeded with proper material digest normally with the speed equal to that of sewage solids. Unseeded feces takes more than 10 times as long. In his experiments, mixtures of feces and urine do not digest quickly even if seeded. Snell succeeded in the digestion of urine by adding cellulose, straw, starch, sucrose and garbage.

Howard (1935) experimented with the composting of night soil by adding it to other agricultural residues and municipal rubbish. He was able to demonstrate that the temperatures reached in the compost pile were effective in inactivating most of the pathogens. Further modifications of this process resulted in the creation of the Calcutta method of composting in which the compost is made in bricklined pits instead of mounds or trenches.

In the later part of the 1930's, Dr. Scharff (1940), inspired by the work of Howard, introduced the composting of night soil into Malaya. He reports successful night-soil composting operations in three large centers drawing supplies from about 10,000 inhabitants yielding approximately 3 tons of crude compost daily. Scharff used two methods of composting night soil. With the Calcutta method, a battery of bricklined trenches, 12' long, 4' wide and 2' deep, is constructed. Appropriate amounts of refuse are dumped daily into the trenches, then crude night soil undiluted with water is poured directly from the night-soil pails onto the layer of refuse. About 1 gallon of night soil is required for each cubic foot of refuse. Immediately after adding the night soil the refuse is thoroughly mixed using a long rake. The pile is formed and left undisturbed for a week. No watering is done. In very wet weather, a loose layer of leaves or grass is used to protect the heap from



excessive moisture. At the end of a week, the rubbish is turned and is drawn over to the side and another pile is formed and left to mature for two weeks. It is then removed and stacked in a heap on a concrete floor for another two weeks, by which time it is ready for use. Scharff reports that the average temperature recorded during the first 2 weeks is 145°F (59°C).

The Indore method of composting was also used in Singapore. Well-drained land, free from flooding, is suitable for this method of composting. The area required is leveled and drained with shallow earth drains. Village refuse is packed loosely in heaps. A trench in the refuse is filled with well-stirred crude night soil. The top of the trench is then covered over loosely with refuse drawn from the side of the heap. The quantity of night soil filling the trench should be equal to about 1/6 of the volume of the heap. The heap is left undisturbed for one week, except for daily moistening with water in dry weather. No watering is done during wet weather. At the end of the first week, the heap is turned so the outer portion of the heap becomes the inner and the rubbish inside the heap forms the outer covering. An additional volume of crude night soil is added, equal to about 1/10 of the volume of the heap. The top of this trench is then covered over with partially composted refuse. At the end of the second week, the operation is repeated with the same quantity of night soil again added. At the end of the third or fourth week the heap is again turned but no more night soil is added. Daily watering is discontinued. The heaps are now left to mature for one month. In the event of heavy rain a loose covering of grass or coconut fronds is laid over the heaps. Two months after the commencement of composting, the heap will have reduced to almost 1/3 its original size. The compost is then fully matured and according to Scharff, can be used on the land. Temperatures recorded in the Indore method are relatively higher and more prolonged than in the Calcutta system. The temperatures reached in the first week average 160°F (65°C) and this heat is maintained at a high level (average 150°F) during the first three weeks. Fly maggots may be seen on the surface of the heap during the first week but disappear after the first turning of the heap. Scharff reports that by the end of the third week the compost is free from intestinal worm eggs. In his paper, Dr. Scharff also reports that the sludge from the municipal works in Singapore was heat treated from the gas evolved in the Imhoff tanks, starting in 1932. It reached a temperature of 140°F (57°C). Tests carried out by Dr. Gilmore, the municipal bacteriologist of Singapore, indicated that at that temperature all pathogenic organisms which may be present in the sludge, including the eggs of intestinal worms, were effectively destroyed.

It is interesting to note that on the conclusion of Dr. Scharff's successful composting experiments with night soil and on seeing the good agricultural returns from the fertilized fields, he stated that he was "... prepared to prophecy that composting of night soil in the villages of Malaya will cause a revolution in the sanitary organization of the rural areas," and affirmed "... that it is clearly the duty of health officers to

encourage the composting of night soil together with municipal refuse or agricultural wastes so as to provide a satisfactory hygienic solution to a severe sanitary problem as well as to provide fertilizer to improve the nutrition of the population."

Stone (1949) provides one of the early reports of composting in China. He reports that in the rice-growing areas, fecal matter is mixed in pits or clay containers with ricestraw, ashes and garbage. The mixture contains about 90% water and digests anaerobically with a great loss of nitrogen, the nitrogen content being 0.62% in fresh mixtures of feces and urine and only 0.26% in the digested mixture. Stone succeeded in Shaoyang, China, in controlling the digestion in such a way as to lower the loss of ammonia nitrogen to such an extent that the higher fertilizing quality obtained covered expenses. He claims that he was able to establish aerobic digestion at between 60° and 65°C in a warm, moist climate of 22°C by laying alternate layers of 4 parts of ground ricestraw, 2 parts of night soil, and 1 part of powdered bone with enough lime to keep the pH at 7.1. Stone reports that the carbon nitrogen ratio was kept at 20:1. The first batches digested in 50 to 60 days and gave a semi-solid humus-like mass, which after 7 days of drying in a layer about 15-cm thick had the following chemical composition:

|  |       |
|--|-------|
| Total nitrogen                                 | 3.94% |
| Phosphates (as P <sub>2</sub> O <sub>5</sub> ) | 1.50% |
| Potassium (as K <sub>2</sub> O)                | 2.27% |
| Moisture                                       | 42%   |

Similar results were achieved in Hong Kong. Stone reports that owing to the high temperatures of digestion between 60°-65°C in the first days and 49°C or less in the next 15 days the product was practically free from pathogenic germs and Ascaris eggs.

Studies on the composting of human excreta with other kinds of organic refuse were carried out in northern China by Scott and his collaborators at Cheeloo and Yen Chin Universities prior to World War II in order to find methods capable of producing a better final product from the agricultural point of view and to eliminate the dissemination of pathogenic organisms and intestinal parasites (Scott, 1952). Both aerobic and anaerobic methods were studied. Scott was able to demonstrate with aerobic composting, in which fecal matter was composted with vegetable matter in mixtures of varying proportions and with the addition of some soil and small quantities of vegetable ash or horse and cow manure in varying proportions, that he was able to obtain temperatures of 55°-60°C, at which level, they would remain for 3 weeks, except immediately after the subsequent turnings. Practically all the Ascaris eggs were dead and protozoan cysts were eliminated. Scott reports that the optimal micro-biological action was obtained with a moisture content of between 50% and 60%. Fly breeding was insignificant. Anaerobic composting took a little longer than 3 months and showed a better nitrogen conservancy but a somewhat less effective destruction of Ascaris eggs. Scott devoted considerable efforts to obtaining optimal nitrogen conservation using various combinations of night soil and vegetable matter.

Hamlin (1949) found in South Africa that excreta of the non-European population which lives on carbohydrates were almost indigestible but could be composted when mixed with excreta of the European population which lives on a different diet.

Night-soil composting methods pioneered by Howard were introduced into various parts of Africa. Van Vooren (1949) in South Africa and Wilson (1948) in East Africa have both reported consistent success using variations of Howard's original methods. The process was introduced into Nigeria by Gillis (1946) in 1941. The first composting plant was near Kano. After a trial period the system was extended to other larger townships in northern Nigeria. During the period 1950 to 1960 there were 5 large composting depots in Kano which were working continuously. Night soil from some 3,000 bucket latrines was treated daily together with most of the city's garbage and litter. The ruminal contents of all cattle, sheep and goats slaughtered in Kano's two abattoirs was also disposed of in the same manner. The average weekly kill was of the order of 700 cattle and 2,000 small animals. The techniques used were based on the Indore system. Appropriate quantities of night soil were thoroughly mixed with carefully sorted refuse. The mixture was loaded into concrete chambers and the whole mass was thoroughly turned on three consecutive occasions after 5, 15 and 30 days. At the end of 30 days, the process was complete and the resulting compost was a dark material resembling soil with an earthy, inoffensive odor which did not attract flies. According to Peel (1973), under normal operation, temperatures over 68°C in the center of the compost mass were regularly reached in the dry season although these were slightly lower during the rainy season. No temperature measurements of the outside layers of the pile were reported but they were presumably lower than those reported for the center. Peel reports that when composting was first introduced into Nigeria in 1951, Gillis encountered a certain amount of prejudice among the indigenous farmers who were reluctant to handle a product in which human excrement was a constituent, but by painstaking educational work and demonstrations he and his staff were able to overcome this and eventually the agricultural community developed considerable faith in the manurial value of the compost and frequently traveled long distances to the nearest depot where it was supplied to them for a nominal charge; demand frequently exceeded supply at certain depots.

It was Peel's opinion that manual composting must always be a primitive operation which is difficult to control, with a highly variable quality of the end product. He reports that it was decided to initiate a pilot project in the city of Kano for the establishment of a mechanized night-soil compost operation. An engineering firm from the United Kingdom prepared a provisional design and a large area of land on the outskirts of the city was selected for a central depot. All of the existing depots were to be closed down. The project was not carried out following the administrative reorganization in the 1960's.

Peel, in concluding his review of the composting of night soil in Africa, states "Health standards of the vast peasant farming communities, although slowly improving, are still low and two of the principal contributing factors to this low standard are the continuing high incidence of fecal-borne

disease and widespread malnutrition. Thus, measures to secure improved nutrition and to control these infections are of paramount importance in each country's public health program." Peel feels that the effective composting of night soil together with other organic wastes under controlled hygienic conditions can contribute to the solution of these two problems. He states that although it has been thought that the local climate in some parts of Africa is unsuitable for the introduction of composting it is possible to overcome these conditions by proper composting arrangements.

He further states that in some areas there may well be local prejudices against the use of the compost which contains human excrement. He feels that in these circumstances a vigorous campaign of education and practical demonstration by both the health and agricultural authorities may be necessary.

In conclusion, he states, "It is not claimed that composting will provide a complete solution to the mass of problems of ill health and malnutrition which face governments in tropical Africa today, but experience has shown that a properly designed and supervised system will secure a substantial reduction in fecal-borne disease and will provide a valuable end product which enables plant nutrients present in organic waste to be returned to the soil. Thus the benefits to be obtained from the adoption of this method of waste disposal are such that they merit the most careful consideration by administrative, public health and agricultural authorities throughout the Continent." Mr. Peel, who was formerly chief health superintendent in Sierra Leone and northern Nigeria, is of the opinion that in the present financial climate in Africa simple manual composting schemes should be the most attractive since little capital outlay is required and the end product has a cash value which can substantially reduce the operating costs of the project. During the discussion of Mr. Peel's paper, it was brought out that the composting plant at Kano, which apparently is still in operation, is not popular because of odor nuisances. Peel admitted that it was not a completely hygienic system. He stated that there were no outbreaks of disease which could be contributed to the failure of the composting system. However, he did feel that despite the economic advantages of simple manual composting there would be a need for more mechanized foolproof composting municipal systems in the future.

Petrik (1954) in his excellent survey on the utilization of night soil, sewage and sewage sludge in agriculture, points out the hygienic and agricultural advantages of composting night soil. He states, "In spite of the fact that there is not much sympathy among sanitarians for the agricultural utilization of human excreta and night soil, it seems that such a use is in many agricultural countries not only highly important economically but also a good method of ultimate disposal. Therefore, both the agricultural and sanitary aspects of such disposal deserve further study."

A similar view was taken by the World Health Organization Expert Committee on Environmental Sanitation at its third session (WHO, 1954) when it stated: "The Committee recognizes the widespread use, in many parts of the world, of human excreta as fertilizer ... with the growing world population

and the limited extent of world resources all efforts to utilize sanitary byproducts and return them to the soil should be encouraged. The necessity of controlling these activities in such a way as to reduce to an absolute minimum their inherent public hazards cannot be too strongly emphasized."

6. Modern Developments in Composting Sewage Sludge and Night Soil

In those countries of the world where central water-borne sewage systems are almost universal for urban areas, the problem of the treatment and disposal of sewage sludge has become a major issue in wastewater management and pollution control due to the heavy expenses involved and the large areas of land required for drying sludge. Rudolfs (1942) studied various aspects of the use of sludge as a fertilizer. He considers sewage sludge a good soil-builder with some fertilizing value and containing relatively small amounts of the main fertilizer elements and minor elements and materials advancing the growth of plants which may be used to advantage in some soils. However, he recognized the unfavorable attitude toward sludge utilization by sanitary engineers in general by the fact that they have looked upon the sludge problem "... as a question of the destruction of noxious matter rather than conservation." The Agricultural Research Council of Great Britain (1948) concluded from 80 experiments with sewage sludge that the sludge is of moderate but positive agricultural value as a slow source of nitrogen and phosphate. Various studies on sludge utilization have been carried out in the United States, South Africa, Canada, and Germany and have been fully reported upon by Petrik (1954).

a. Windrow Sludge Compost Plant in Los Angeles County Sanitation District

Current interest in sludge composting and utilization is exemplified by the studies carried out by the Los Angeles County Sanitation District (1974). They evaluated six methods of sludge disposal:

1. Incineration
2. Compost-air drying
3. Mechanical drying
4. Direct hauling of sludge to a landfill
5. Pyrolytic processes
6. Pipeline disposal to a remote location

In evaluating the proposed alternatives, the main criteria were reliability, annual cost, social and environmental impacts and resource recovery. Pyrolysis and pipeline disposal were eliminated in the initial screening process because of the high initial cost and limited data on the feasibility of a large-scale system. They concluded that the ultimate disposal of sludge to any of the three natural sinks, air, land, and water, is strictly controlled by a number of regulatory agencies and environmental constraints. However, they felt that all of the disposal alternatives are capable of meeting these constraints provided adequate precautions are taken during the design, construction and

operation of the system. Compost-air drying was found to be superior in the cost analysis due to its relatively low capital, operation and maintenance costs. It also involved the lowest use of scarce resources. It was determined to have the least negative environmental impact. Based on the foregoing analysis the Los Angeles County Sanitation District selected compost-air drying as the recommended disposal method. It established a large-scale windrow sludge composting system at the Joint Water Pollution Control Plant (County Sanitation Districts of Los Angeles County, 1975).

At that plant, in 1974, composting of dewatered-digested sludge was initiated on a routine basis on a 40-acre plot of land using the windrow process with mechanical equipment for turning the piles. They used the Cobey Rotoshredder composting machine, turning the sludge and old compost added to it several times a day for the first days of processing both to achieve complete mixing and aeration of wet and dry material. Each windrow must be turned initially 2 or 3 times a day to minimize odors and to insure sufficient oxygen transfer. The sludge is then turned daily for a period of about 30 days. The plant is presently handling up to 1,200 tons per day of sludge (23% solids) (see Figure 1).

Major items of heavy materials handling equipment are required for the operation: 4 Cobey Rotoshredders, 9 large "Flowboy" trailer units, 2 forced-feed loaders, 2 dry-sludge transfer trucks. Composted dried sludge is presently transferred by the Kellogg Supply Company, with earthmovers, to a neighboring site. Distribution and sale of the composted sludge as an organic soil conditioner shows a highly successful marketing record in the area.

The windrow compost piles have a base of 15', a height of 4'3", a width across the top of 6', and a distance of 3.75' between piles. This configuration allows for a sludge volume of 3,900 cubic yards per acre. Maximum temperatures in the central portion of the windrow reach as high as 160°F (65°C). The operating temperatures of about 150°F (61°C) in the central portion of the windrow apparently are maintained for as much as a 10-day period. Data for the temperature of the outside layers of the windrow are not available, but it is apparently lower than the center.

According to the composter specification, the unit which cost about \$130,000 is capable of processing 3,400 tons per hour at a density of 70 lbs. per cu. ft. This translates into a volume capacity of 3,600 cubic yards per hour. Based on an assumed residence time of 40 days in the windrows, assuming that the windrows must be turned twice a day for the first 5 days and once per day for the remaining period, it has been calculated that 3 machines operating continuously during two shifts a day would be required. A fourth machine is required for standby in the case of failure which might result in the affected machine being out of service for up to 10 days. In the case of rainfall the processing time would require 4 machines operating in two shifts, or 3 machines operating continuously. Therefore, the minimum number of machines required for assured operation is four. Problems with composting

**Figure 1. Design Assumptions for Composting/Drying System  
County Sanitation Districts – Los Angeles**

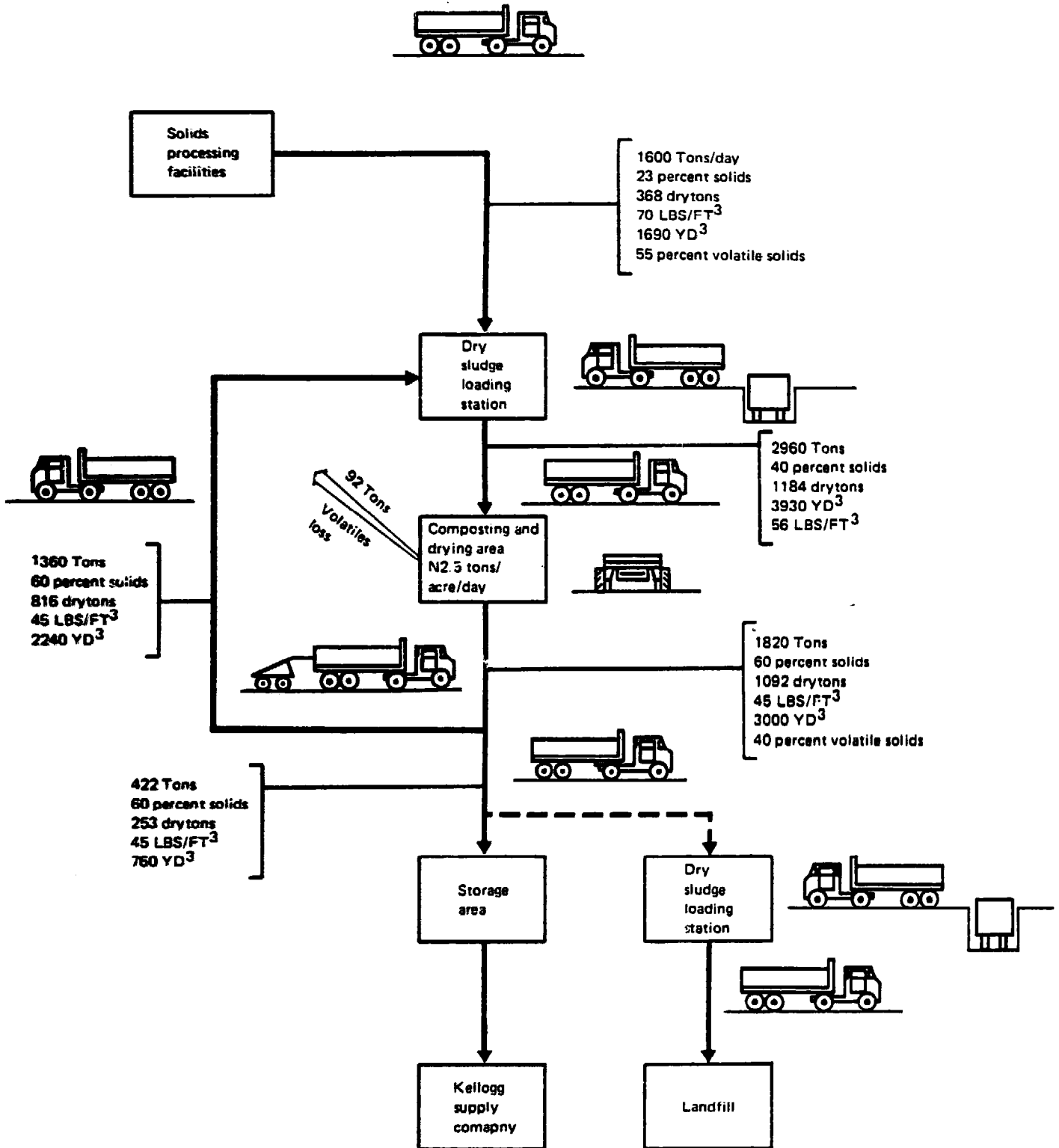

machine maintenance service have been reported. A visit to the Los Angeles County Sanitation Districts Joint Water Pollution Control Plant was made on July 20, 1977. No odor nuisances were detected and the plant was operating at full capacity under satisfactory conditions.

Intensive studies have been carried out by the Los Angeles County Sanitation Districts to determine the pathogen inactivation during the windrow sludge composting process (Smith and Selna, 1976 and 1977). Sludge samples have been analyzed for human parasites, bacteria and viruses. The proposed California State Health Department standard for sludge that is to be sold as agricultural fertilizer is a total coliform count of less than or equal to 1 MPN per gram of sludge. Additionally, the absence of human parasitic ova and viruses is required. Ascaris ova have been detected consistently and in abundance at the beginning of each of the compost cycles. However, embryonated ova have been detected only through the first 10 days of composting. Embryonated viable ova have been detected near the end of the compost cycle infrequently. Ova of Trichuris trichuria and hookworm have been less frequently isolated throughout the compost cycles. As with Ascaris, viable representatives of these two parasites have not been consistently detected after the first week of composting. The coliform standard of less than 1 MPN per gram was met only in the interior samples during warm climate periods when the composter was in continuous operation. Regrowth of coliforms in the exterior of the composting windrows has been detected. This regrowth is believed to be due to lower temperatures in the pile exterior. In general, fecal coliform concentrations match the total coliform concentration. The majority of the coliform concentration typically detected in composts at the Los Angeles plant can be accounted for as fecal coliforms.

Salmonella assays were performed less frequently than the coliform assays, but also indicate rapid kill within the first 10 days of composting. In most cases, during warm climate composting cycles the detection limits of less than 0.2 MPN per gram Salmonella was observed although salmonella organisms were detected in a few samples of final compost. Since this organism is not an obligate pathogen it can regrow outside the human host but in general the limit of detection of Salmonella was much shorter than the period of time to reach the minimum concentration of coliforms. This indicates that the rate of inactivation of Salmonella during composting was greater than the rate of inactivation of coliforms (see Figure 2, showing typical bacterial concentrations versus time during composting operation).

Considerable effort has been made by the Los Angeles group to develop methods to effectively assay compost for viruses. Although the methods still are not considered completely reproducible, viruses were not detected towards the end of the compost cycle.

In conclusion, the Los Angeles group has found that temperatures as high as 60-65°C have been produced at the center of the compost heap during composting cycles when rain did not occur and when the composting apparatus was consistently available throughout the cycle. Low ambient temperature, rainfall, and composter malfunctions cause temperature in the interior of the compost windrows to reach a maximum of 55-60°C during the



Figure 2. Bacteria Concentrations vs. Composting Time (Los Angeles)

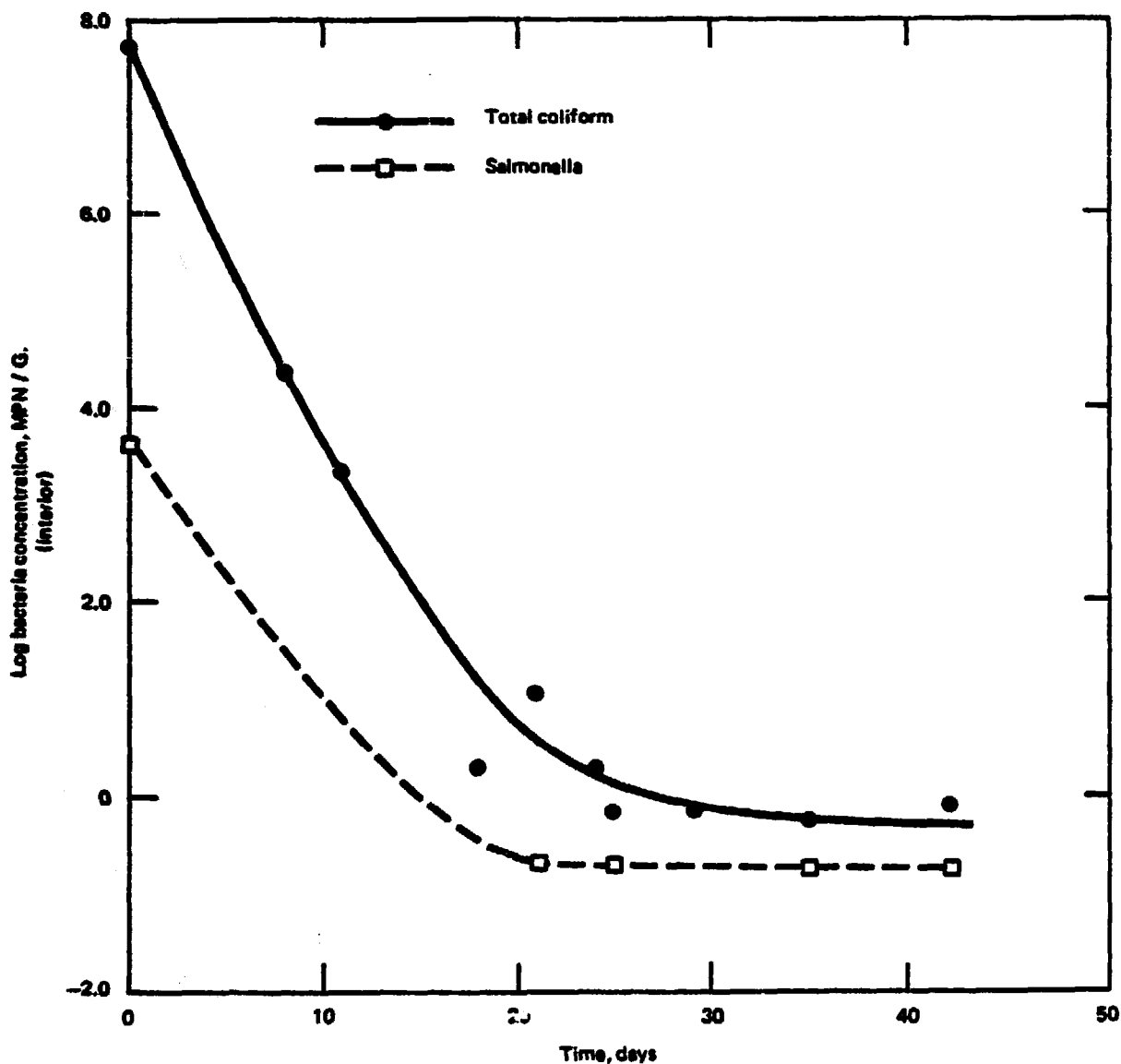

Note: 1. Operation mode = 1 turn/day; 2. dates: 4-12-76 to 5-24-76

Source: Smith and Selina, (1977).

winter months. The outside portions of the pile are of course considerably cooler. Viable Ascaris ova have been isolated in only three of the final compost samples collected during their study, while only six of the 116 samples collected after more than 10 days of composting contain embryonated Ascaris.

Total coliform and Salmonella concentrations are rapidly reduced in the first 10 days of the composting period. Final compost coliform concentrations of less than 1 MPN per gram have been achieved during warm weather composting in samples collected in the interior of the compost windrows. Exterior windrow samples have not been below 1 MPN per gram with consistency. Final compost Salmonella concentrations of less than 0.2 MPN/g have been achieved in both interior and exterior samples collected from warm climate compost cycles. Regrowth of Salmonella during winter compost cycles has been observed but it has not been determined whether poor winter performance was due mainly to climate or failure of the composter. Assays of virus, parasitic ova and Salmonella have yielded negative results in the vast majority of final compost samples, whereas total coliform concentrations in final compost samples have not been uniformly below 1 MPN per gram.

Generally satisfactory results as far as bacterial and pathogen inactivation are concerned have been obtained. Probably better results with higher temperatures could be achieved in higher compost piles, but this is not presently feasible due to the configuration of the existing composting machines. There also have been operational problems with the composting machines which have led to failures in the process at times.

In conclusion it can be said that the composting air-drying operation of the County Sanitation Districts of Los Angeles County provides a good demonstration of the feasibility of sewage sludge composting on a large scale with relatively good pathogen inactivation. The heavy capital investment in their complex composting equipment and other materials-handling equipment makes this process relatively expensive and subject to serious operational and maintenance problems, limiting its suitability for developing countries.

b. The Beltsville Aerated Rapid Compost (BARC) System for Composting Waste Water Sludge

Dr. Eliot Epstein and his group at the Agricultural Environmental Quality Institute of the U.S. Department of Agriculture Research Station at Beltsville, Maryland, have been experimenting with sewage sludge composting for a number of years.

Their first efforts were in the direction of windrow composting, in which the digested sewage sludge was mixed together with bulking materials such as wood chips and composted in open windrows using various composting-turning machines, including the Cobey Rotoshredder currently used in Los Angeles. Temperatures reached at the hottest point in the compost piles were as high as 60°C on a number of occasions, while the temperatures of the outside layers of the piles were considerably lower. The piles were turned daily.

Results of their studies on the destruction of pathogens in the composting of sewage sludge were reported by Burge, et al. (1974). In the first studies, total and fecal coliforms were greatly reduced during 2 weeks of windrow composting in the surface (0 to 20 cm), subsurface (20 to 40 cm) and interior (80 to 100 cm) of the windrows. During the 4 weeks of the stockpile phase these organisms survived in the surface and subsurface but were destroyed at depth. Salmonella numbers increased during the early part but were essentially destroyed by the end of the windrow phase. Enteric viruses were detected during the windrow phase but were not detected during the stockpile phase. The above results apply to both digested and raw chemically precipitated sludge. Total and fecal coliforms increased in numbers in composting of chemically precipitated raw sludge during the winter months, Salmonella numbers increased only sporadically.

During the winter months  $F_2$  bacteriophage was incorporated into the sludge. During the winter months  $F_2$  was destroyed despite the low ambient temperatures affecting the efficiency of composting. The authors report that weather conditions greatly influence the ability of the windrow composting process to control pathogens. In the fall, during the composting of the digested and chemically-precipitated raw sludge, coliforms, and Salmonella were considerably reduced in the windrows and essentially wiped out in the interior of the stockpiles. The total and fecal coliforms, however, continued to survive in the stockpile surface (0-20 cm) and subsurface (20-40 cm). During winter composting of chemically-precipitated raw sludge, the total and fecal coliforms increased in numbers with composting indicating they were growing in the portion of the compost windrows and stockpiles in which killing temperatures were not reached. The initial salmonella concentrations were low and for the most part remained at low levels. Viruses were present in the digested and chemically-precipitated raw sludge samples composted in the fall. Tests for their presence were positive during much of the windrow phase including that last tests made, but they were not detectible in the stockpiles indicating that they were eventually destroyed.

The results of these windrow composting studies led Epstein and his group to investigate more efficient ways of composting so as to assure temperatures in the upper thermophilic range during the entire composting period and to guarantee the inactivation of pathogens in all portions of the pile. The system developed, called the Beltsville Aerated Rapid Composting (BARC) method, was based on the building of static piles of mixed sludge and wood chips used as a bulking material (Epstein et al., 1976). The wood chips which were added to the sludge in a ratio of 1 part sludge to 2 parts wood chips reduced the moisture content from 78% in the initial sludge to 60% in the mixture. Wood chips also provided for a lighter structure of the mixed pile to enable the free passage of air through the pile. The wood chips provided for an increased carbon source. The C/N ratio of the sludge was about 10, which is too low for rapid composting. Perforated plastic drainpipe, 10-cm diameter, was laid out in a loop on the ground and covered with 15 to 20-cm of wood chips or previously manufactured unscreened compost. This

layer absorbed liquids and prevented sealing of the pipeholes by fine particles. The mixture of sludge and wood chips was then placed over the compost and wood chip base and piping system with a front-end-loader. Each pile contained approximately 40 metric tons of filter-cake sludge mixed with wood chips and had the dimensions of 12m x 6m with a height of 2.5m. The entire pile was then covered by a 30-cm layer of finished compost that had been passed through a 1-cm mesh screen. This layer was designed to prevent odors from escaping from the pile surface into the atmosphere as well as to provide insulation for better heat maintenance and reduce the penetration of rain. The pipe system was connected to a 0.33 hp centrifugal blower which was used to draw air through the pile according to a predetermined schedule controlled by a timer. The gases drawn into the pipe were deodorized by passing them into a pile of previously-screened compost (see Figure 3).

Temperatures in the pile increased rapidly into the thermophilic range during the first 3 to 5 days, ultimately rising over 80°C. Temperatures started to decrease after about 3 weeks indicating that the more decomposable organic constituents had been utilized by the microflora and that the sludge had been stabilized (see Figure 4). Temperature measurements were made at 14 points within the pile daily during the experimental composting runs. These points were at various depths within the pile including those at the interface between the sludge and wood chip mixture and the compost cover which should be the coolest area. According to Dr. Epstein's data from over 100 experimental piles, minimum temperature of at least 60°C have been recorded for a minimum of 5-10 days in each composting cycle, while temperatures of 80°C were achieved in the hottest areas. This 60°C temperature is well above the thermal inactivation point of all of the pathogens considered to be of importance in sewage sludge and night soil. This is truly an impressive accomplishment considering the simplicity of the operation which uses a minimal amount of mechanical equipment. It apparently assures failsafe thermal inactivation of all pathogens of importance in the pile.

Extensive studies on the destruction of pathogens in the compost pile have been made. Although Salmonella, fecal coliforms and total coliforms increased initially in numbers, they were reduced to essentially undetectable levels by the tenth day. Studies using F<sub>2</sub> bacteriophage or virus as an indicator showed that the virus was essentially destroyed by the thirteenth day. Survival of the virus did occur for some time, however, in the blanket-compost mixture interface where lower temperatures prevailed. Storage in a curing pile for 30 days, in accord with the present process technology, should complete the destruction of viruses or at least reduce the numbers to an extremely low level (see Figures 5 and 6 on bacterial and virus inactivation). The authors state that the numbers of coliforms and salmonella may increase in the outer layer of the curing piles where the conditions for regrowth are more favorable. Studies are in progress to assess this possibility. Epstein and his colleagues feel that their studies demonstrate that composting with forced aeration is essentially unaffected by low ambient temperatures and/or rainfall, which makes this system particularly attractive for operations under various climatic conditions. The BARC system

**Figure 3. Schematic Diagram of an Aerated Pile Indicating Location of Aeration Pipe. Loop is Perforated for Air Distribution (millimeters)**

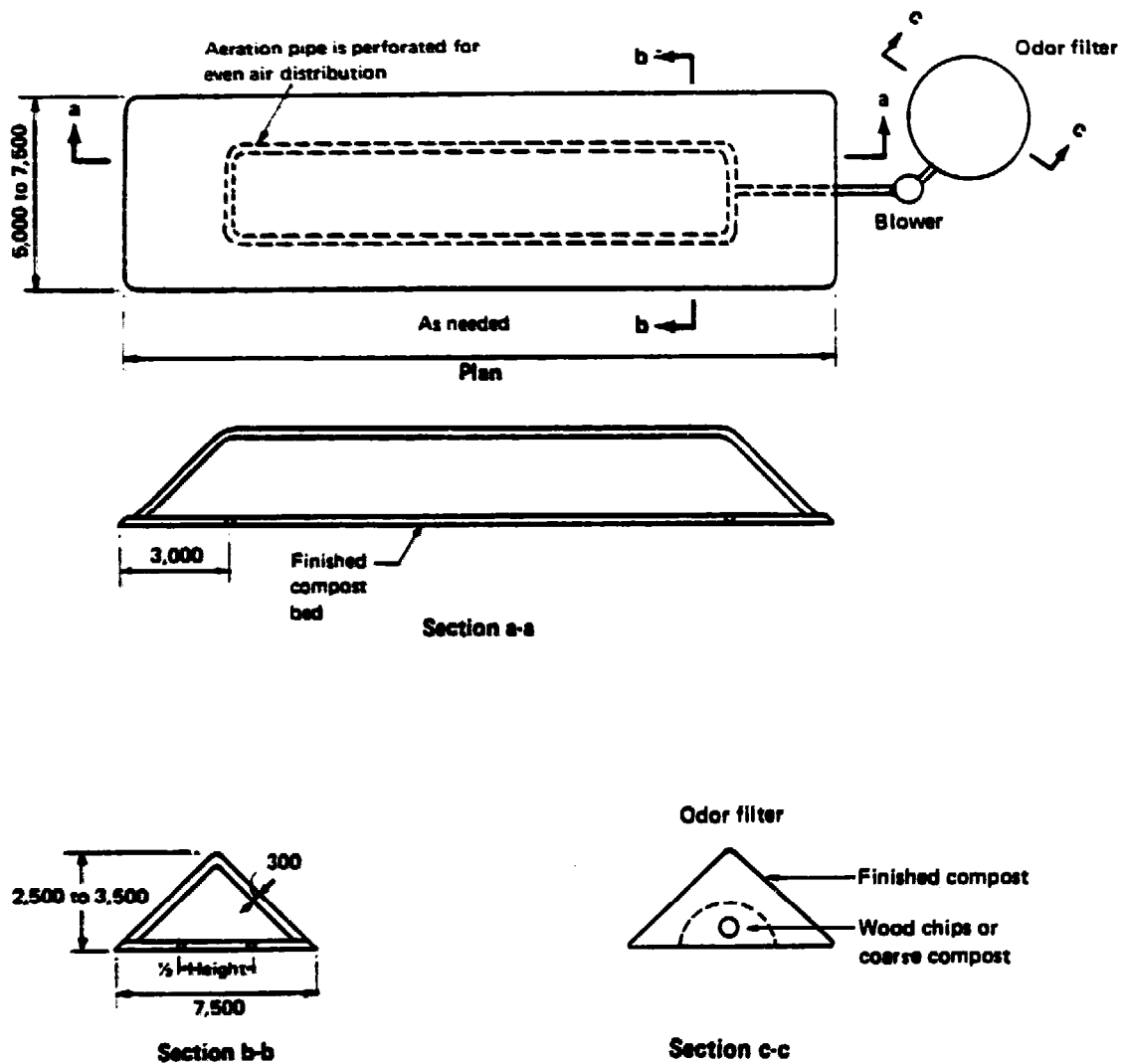

**Schematic**

Figure 4. Temperatures During Composting of Raw Sludge (May 1975)

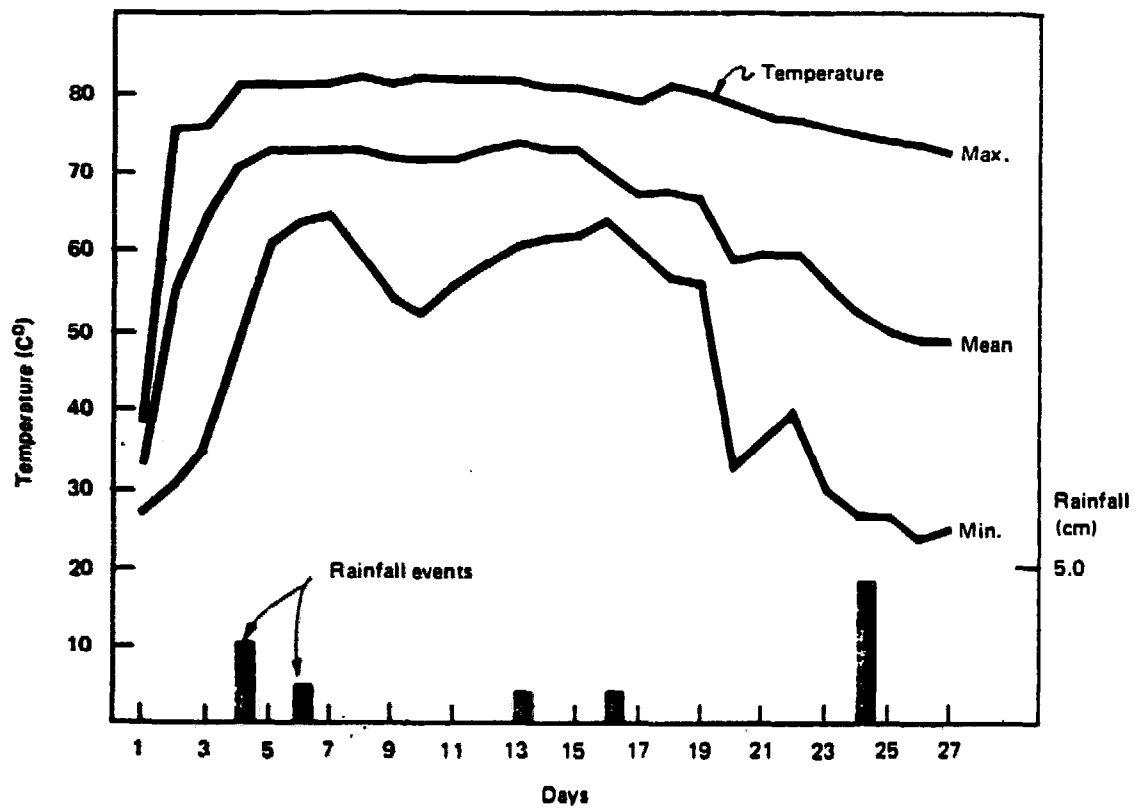

Source: Epstein Et Al, 1976).

**Figure 5. Destruction of Salmonellids, Fecal Coliforms, and Total Coliforms During Composting by the BARC System**

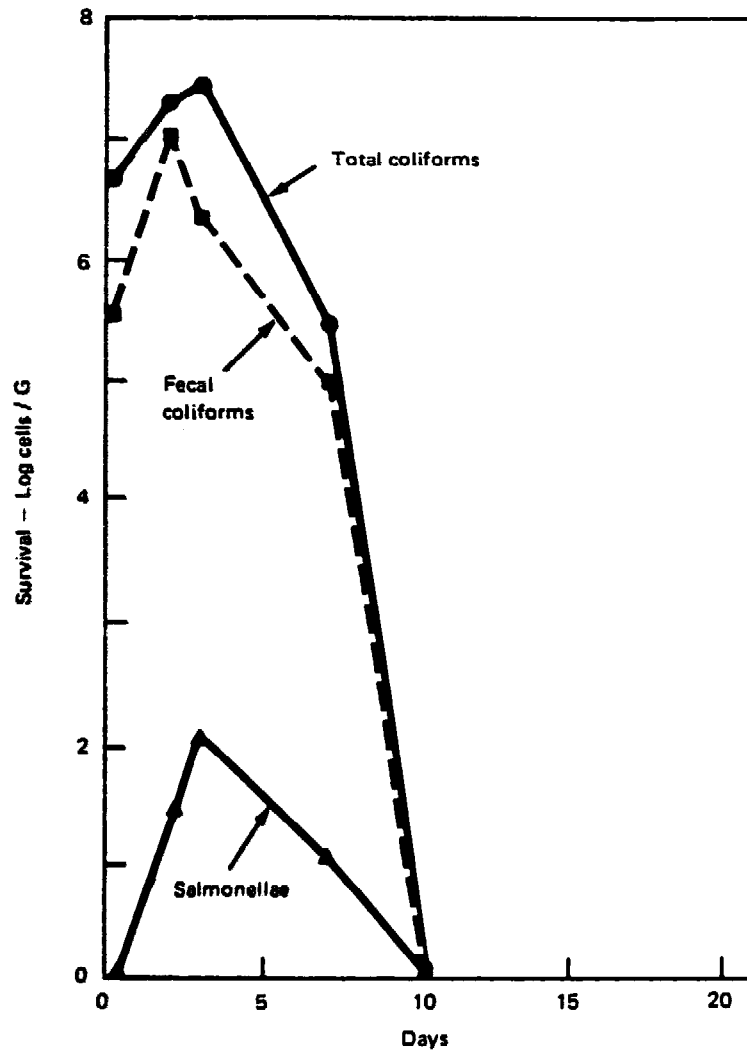

Source: Epstein Et Al, (1977).

**Figure 6. Destruction of F<sub>2</sub> Bacterial Virus During Composting by the BARC System**

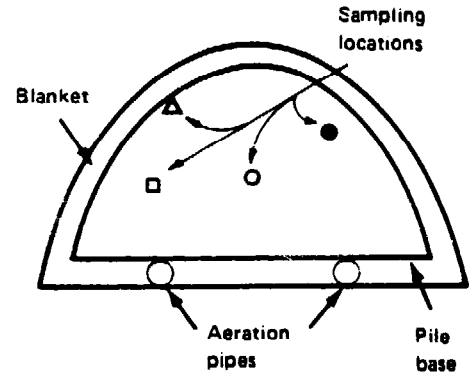
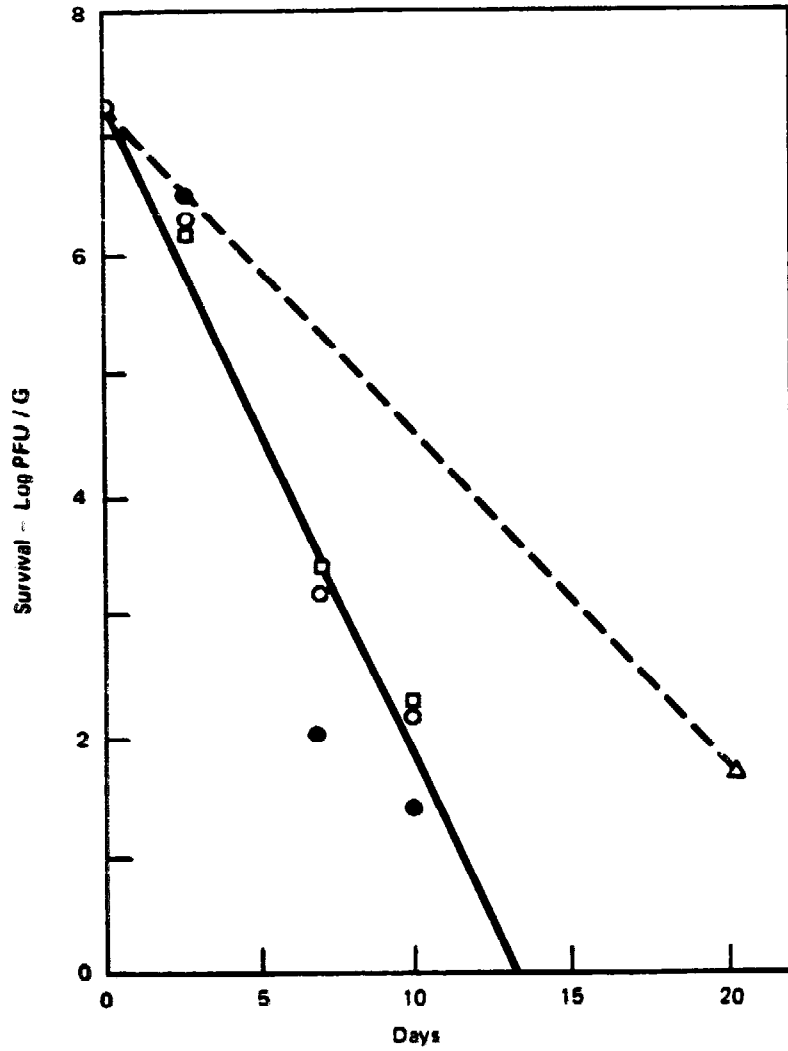

Source: Epstein Et Al, (1977).



is currently in operation since 1975 in Bangor, Maine, serving a population of 50,000 persons and handling 50 tons filtered primary and secondary undigested sludge at 22% solids per week. The thermophilic bacteria apparently continue operating to heat the pile to above 55°C in the aerated compost pile even during periods of sub-zero weather common in that area. The external layer of well-composted material insulates the pile and effectively prevents the cooling of the compost pile during heavy rains.

The BARC system is no longer in the experimental stage and at Beltsville is operating on a full-scale composting basis using filter-cake from the Blue Plains Sewage Treatment Plant in Washington. The plant has been operating routinely since early 1975 receiving 60 wet tons of sludge per day for processing; this is equivalent to the sludge produced from a plant serving a population of 125,000. They have been able to demonstrate the feasibility of a large-scale routine operation of the plant. In a site visit to the plant operation on July 12-15, 1977, no nuisances were detected, fly breeding was not present, nor were odors typical of many composting operations.

It has been reported that there are very few mechanical problems with the simple blowers used in the system. The unit is relatively inexpensive, costing about \$100 and can be easily replaced in case of failure. There is small amount of liquid extracted through the blower system, which serves as a drainage system for the compost pile. This liquid has a BOD of about 3,000; it is drained away to a stabilization pond adjacent to the compost site which also receives the general site drainage. In a very rainy climate, the leachate rate may prove to be a greater problem and special facilities should be designed to deal with this. The Beltsville plant is now on an asphalt surface although earlier it was operated on gravel-covered soil surface. A well drained soil base may be satisfactory under the conditions of limited rainfall. However, with plants with different soil and rainfall conditions it might be necessary to operate the plant on a hard surface area covered with asphalt or concrete. The wood chips and sludge mixture is made with a front-end loader which is standard earth-moving equipment. The mixing process is carried out on a paved area.

The area required for the BARC system has been estimated to be 1 hectare per 10-12 dry tons per day of sewage sludge. This area estimate includes (1) areas for mixing the sludge or night soil with bulking materials, (2) the area required for composting, (3) the area required for storage and curing piles and long-term storage before marketing, (4) the area required for screening of the final compost and separation and recycling of wood chips, (5) area required for lagooning or oxidation ponds of leachate and drainage from the composting area, and (6) area required for administration, workshops, parking of vehicles, and storage of spare parts.

As more experience is gained using the BARC system of composting, it will be possible to refine the design criteria concerning area requirements so that design estimates can be made. Without knowing soil conditions in advance, one should assume that 50% of the area should be paved. However,

with proper firm, well drained soil it might be possible to carry out the simple composting on unpaved areas, except for the mixing surface. A mechanical mixing device such as a "pug-mill" could replace the open mixing area.

According to the calculations of Dr. Epstein, the materials balance of the BARC system is as shown in Figure 7. As can be seen from this figure, for 1 ton of dry weight of sludge, 2 tons of wood chips are added to make up the mix while 0.69 tons of wood chips are used to make up the base of the pile, and 1.42 tons of screened compost is used to cover the pile, adding up to 5.11 tons dry weight in the pile for every ton of sludge entering the plant. However, according to the Beltsville procedure, the wood chips are recycled and only 0.64 tons of wood chips must be added for each incoming ton of sludge as makeup. Screened compost is also recycled as a cover for the piles and according to Dr. Epstein's calculations for every ton of dry sludge solids entering the plant, 1.13 tons of marketable screened compost is produced.

In addition to the BARC system in operation at Beltsville, Maryland, there are a number of other full-scale BARC composting plants with operation, including Windsor, Ontario, and Bangor, Maine and Durham, New Hampshire.

A site visit was made to the BARC sludge composting plant in Windsor, Ontario on July 18, 1977. The West Windsor Pollution Control Plant has been composting filter-dried primary sludge cake from a 21 mgd plant since 1976. 15 mg/liter of ferric chloride is added to the raw sludge, then 0.3 mg/liter of an anionic polymer is added. The sludge is concentrated partially by vacuum filtration and partially by centrifuge giving a solids content between 20% to 24%. The pH of the filtered sludge is about 11. In Windsor part of the sludge is hauled 24 miles to a landfill site at a cost of \$6.50 per ton for hauling and landfill. It is estimated that this may go up to \$9 per ton, and there is a possibility that in the future there may be no landfill area available. Therefore, there is a great interest in the possibility of composting the sludge and marketing the final product through commercial channels.

No operational problems have been encountered at the plant and no nuisances were apparent at the site which appeared to be well-run. A wood chip screening and recycling installation is presently under construction using a vibrating screen separating system. The piles at the West Windsor plant are arranged in the piggyback system, that is, each day's pile is laid contiguous to the previous day's pile and covered at the end of the day in such a manner that there is no free space between the piles, which form a single mound. Each pile, however, has its own aeration system (see Figure 8). This configuration reduces the area requirements considerably and has been shown to be highly effective.

Apparently no problems have been encountered composting the sludge which has been treated to a high pH of 11. The pH of the mixed pile with the bulking materials has not been determined. Dr. Ann Prytulla, Director of the Regional Public Health Laboratory, Windsor, has been carrying out microbiological tests of the raw sludge and completed compost since April 1977.

**Figure 7. Materials Balance for the BARC System**

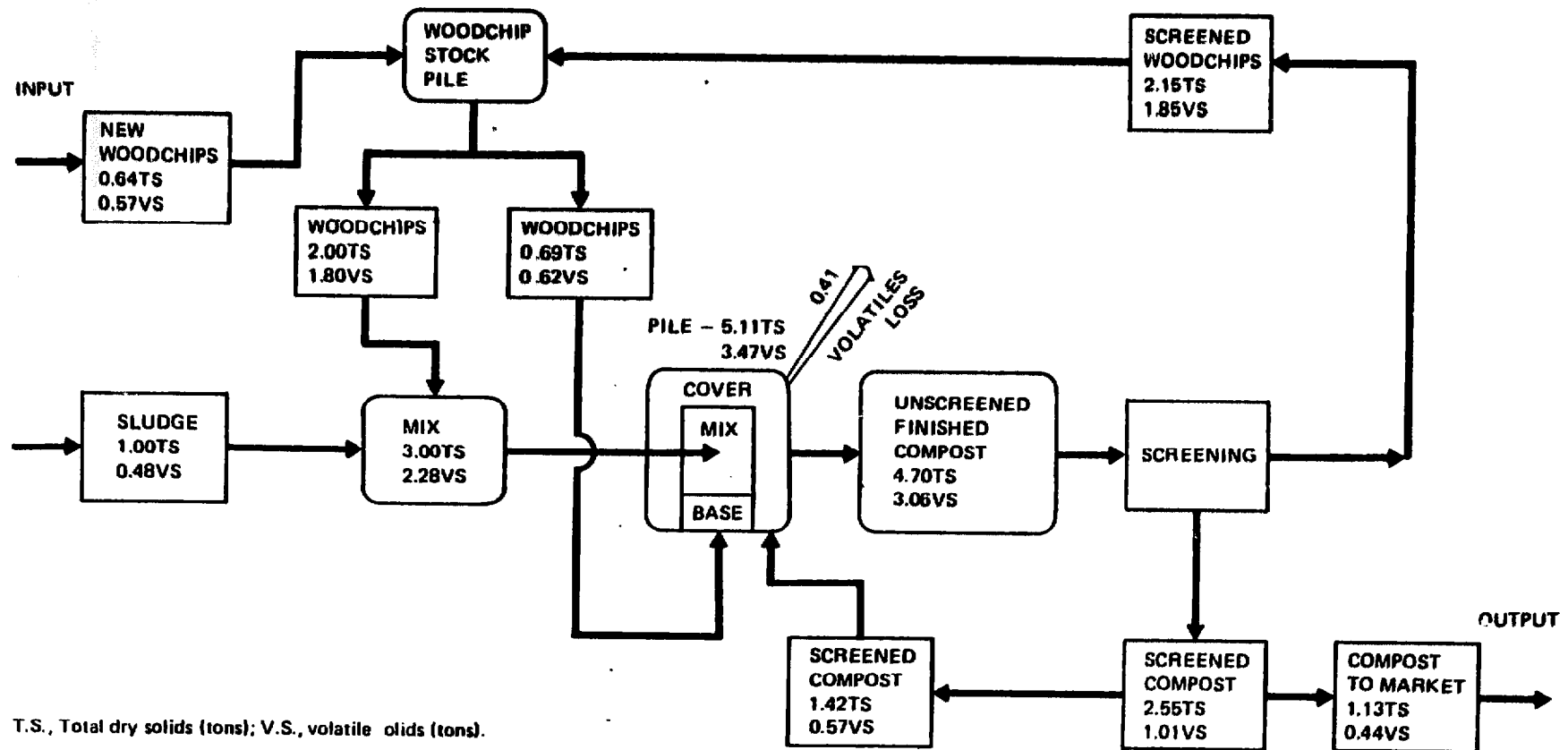

T.S., Total dry solids (tons); V.S., volatile solids (tons).

| Assumptions:   | Volatile Solids | Water |
|----------------|-----------------|-------|
|                | %               | %     |
| New Woodchips  | 90              | 35    |
| Used Woodchips | 50              | 50    |
| Sludge         | 48              | 78    |
| Compost        | 40              |       |

\*Data from: E. Epstein

**Figure 8. Construction of Extended Aerated Cells for BARC System (millimeters)**

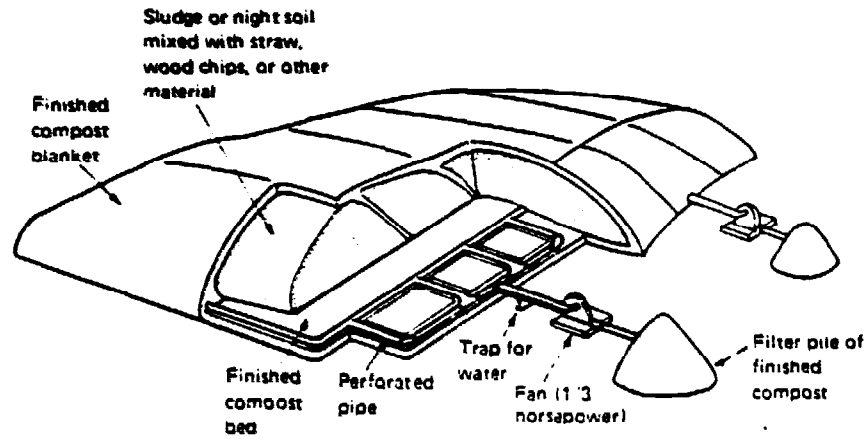

**Composting extended piles with forced aeration**

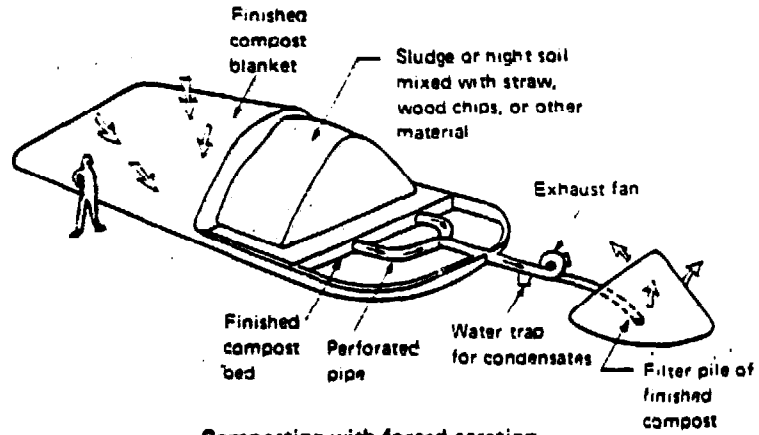

**Composting with forced aeration**

She has tested for coliforms, fecal coli, fecal streptococci, Salmonella and viruses, as well as for parasites, particularly Ascaris and Giardia. Temperature measurements are taken at regular intervals from a number of sites within the pile including points at the center of the pile and at the periphery next to the cover and next to the bedding. The site nearest the outside cover next to the bedding usually is the coolest spot in the pile. Even at that spot, temperatures of 60°C have been recorded for several days during the 21-day composting period.

Initial bacterial counts for coliforms are of the order of  $10^8/100$  grams; for fecal coliforms, about  $10^7/100$  grams; and of Streptococcus fecalis about  $10^6/100$  grams. After 21 days of composting, the total coliform count drops to less than  $10^3/100$  grams. Thirty determinations for salmonella bacteria were made in the finished compost with no positive findings. Bacterial counts of slightly above  $10^3/100$  grams were, however, found at the coolest spot in the pile close to the base and at the periphery. It is felt that this can be overcome by avoiding excess aeration which may lead to the cooling of the pile. While parasite eggs have been found in the raw sludge, none have been detected in the final compost. In the West Windsor plant, 6 acres have been allocated to treat 120 wet tons of sludge per day with 20% solids. The area is gravel covered and has 10 cm drains at 5-meter intervals. The cost of wood chips is \$4 per ton.

c. Composting Night Soil with the BARC System

Mr. James C. Patterson, research agronomist with the National Capital Park Service, Ecology Laboratory, in Washington, D.C., has initiated a project for composting night soil from sanitary latrines in the Dargon and C&O Canal Parks of the National Capital Park System. This project has been carried out under the supervision of Dr. Eliot Epstein, and is based on the BARC system. The night soil is accumulated in the vault of the standard sanitary latrine of the Park Service, which contains 50-75 gal. This vault is emptied by a vacuum truck as frequently as twice a week during the peak season and as infrequently as once every other week during the winter season. A mixture of wood chips, compost, and sawdust is made and formed into a basin onto which the liquid night soil is spread by being pumped from a 1,000 gal holding tank at the compost site, which is used to receive the liquid night soil pumped from the vacuum trucks which extract the night soil from the latrines spread throughout the park. The compost pile is made up about every 3 weeks during the summer season. The raw night soil is estimated to have 95% liquid concentration. According to estimates provided by the Park Department for every volume of night soil, 1.6 volumes of wood chips are added, and 1.0 volume of compost and 1.5 volumes of sawdust. These provide bulking material which absorbs most of the liquid and largely avoids the problem of runoff which was initially encountered (Patterson, 1977). Temperatures up to 80°C have been recorded in the compost pile. The main problems encountered have been using adequate amounts of sawdust to absorb the moisture. About 1% of the liquid night soil applied to the pile runs off as drainage and is disposed of into a lagoon. Analysis of the final compost indicates that

the total organic nitrogen (TN<sub>k</sub>) concentration is 1.3 to 1.6%, phosphorus is 0.6 to 0.7%, carbon is 46% to 50%. No loss has been detected in the nitrogen content in the year of storage of the compost. The night soil has also been tested for heavy metals and the following concentrations have been found:

|              |             |
|--------------|-------------|
| Lead (Pb)    | 128-138 ppm |
| Zinc (Zn)    | 400-790 ppm |
| Nickel (Ni)  | 61-101 ppm  |
| Cadmium (Cd) | 3-7 ppm     |

The pH of the final compost varied between 6.6 and 6.9 and the soluble salts concentration between 960 and 7,000 ppm. It is interesting to note that municipal sludge, as reported by Dr. Epstein, contains 540 ppm lead, 2,000 ppm zinc, and 19 ppm cadmium. The high zinc concentration in the composted night soil for the Park Department is apparently due to the use of a chemical disinfectant containing zinc, called ZEP, in their latrines. Nevertheless, the concentrations of the other heavy metals apparently indicate the amount of heavy metals excreted by humans as a result of heavy metal intake from dietary sources.

Approximately 27,000 gallons (100,000 liters) of night soil is produced each year by the visitors at the C&O Canal Park, a historical park which runs parallel to the Potomac River in Washington and neighboring Maryland. The incentive for composting was the overloading of the local sewage treatment plants which were unable to accept the night soil from the vacuum truck transport vehicles.

Microbiological testing of the finished compost has been carried out by the USDA in Beltsville, Maryland. The results indicate effective inactivation of enteric bacteria including pathogens in the composting process. Composting of night soil by the National Capital Park Service at the site in Dargon using the BARC sytem is in fact the first test operation using this system for composting of real night soil, and can serve as a model for the study of this method. At the moment the project is being carried out with minimal scientific surveillance. In order to gain the maximum amount of information from this operation, it would be desirable to carry out an intensive 1-year study to verify both the engineering parameters and the effectiveness of pathogen inactivation in the system.

#### d. Conclusion

Based on the extensive review of the literature on public health problems associated with pathogenic microorganisms in night-soil and sewage sludge reuse covered in Section 2 of this document and on the review of available composting technology, past and present, it would appear that the best method most likely to be capable of meeting all the objectives for safe and economically feasible night-soil treatment and reuse for developing countries would be the Beltsville Aerated Rapid Composting (BARC) System.

Temperature data from over 100 piles that have been composted by the BARC system indicate that every portion of the pile has reached a temperature of at least 60°C for approximately a 5- to 10-day period during the course of composting. All available evidence indicates that this can provide effective thermal inactivation of the pathogens of major public health significance including bacteria, protozoans, helminths and viruses, producing a final compost which will be free of public health risks. The advantage of the BARC system is not only the very effective and uniform thermal inactivation of pathogens in an assured manner, but the fact that it is a relatively inexpensive method using simple equipment which is particularly suited to developing countries. The final compost produced is of good quality. It is a stable, nuisance-free granular material which in no way resembles the raw materials from which it is made and which may well be socially acceptable even in areas where the direct handling of human excreta is not looked upon with favor. Such compost has a demonstrated agricultural value as an effective soil conditioner.

Based on these conclusions, it is recommended that a major effort be made to develop a number of pilot projects in appropriate areas of developing countries where night soil of varying characteristics can be composted with BARC system with local bulking materials and under the specific local environmental conditions. This is an essential step in providing for a more complete evaluation of effectiveness of the system from a public health point of view under field conditions and to obtain the required engineering parameters required for the rational design of full-scale systems.

#### 7. Economic Aspects of Night-Soil Composting

The following is based on an analysis prepared by Dr. Epstein:

Colacicco et al. (1977) estimated the cost of composting raw (primary) sludge by the BARC method in the U.S. to range between \$38.5 and \$55 per dry metric ton of sludge. The \$38.5 figure relates to a 50 dry ton per day operation and the \$55 to a 10 dry ton per day operation.

In the U.S., it is assumed that each person produces 55 grams of solids per day (primary sludge). Thus a 10 dry ton facility would serve 180,000 persons. Iwai, Honda, and Chang (1962) estimate that the total solids in night soil is 30 grams per liter and assuming 1 to 2 liters of night soil per person per day, then a 10 dry ton facility for composting night soil would serve a population of 150,000 to 300,000 persons. Accurate data of night-soil quantity per capita is not available at this time.

##### a. Cost Estimates for Composting Sludge at Beltsville (BARC)

The capital costs are estimated to be between \$30,000 and \$38,000 per dry ton per day capacity, for facilities with an output of 50 and 10 dry tons capacity per day, respectively. Table 3 shows details of the capital costs in 1976 dollars:

Table 3

CAPITAL COSTS FOR BARC SYSTEM

| <u>Item</u>      | <u>Dollars per dry ton per day capacity</u> |                    |
|------------------|---|--------------------|
|                  | <u>50 dry tons</u>                          | <u>10 dry tons</u> |
| Site development | 16,000                                      | 20,000             |
| Equipment        | 10,000                                      | 14,000             |
| Land             | <u>4,000</u>                                | <u>4,000</u>       |
| <b>TOTAL</b>     | <b>30,000</b>                               | <b>38,000</b>      |

Land costs were estimated at \$10,000 per acre. Equipment costs include front-end loaders, trucks, tractor, mechanical screen and blowers.

Table 4 identifies the operating inputs for a 10- and 50-ton facility:

Table 4

OPERATING REQUIREMENTS FOR BARC SYSTEM

| <u>Item</u> | <u>Quantities Consumed per Dry Ton</u> |                    |
|-------------|--|--------------------|
|             | <u>50 tons</u>                         | <u>10 tons</u>     |
| Labor       | 1.5 hrs.                               | 2.85 hrs.          |
| Wood chips  | 2.1 m <sup>3</sup>                     | 2.1 m <sup>3</sup> |
| Gasoline    | 4.2 liters                             | 4.2 liters         |
| Diesel      | 10 liters                              | 13 liters          |
| Electricity | 7.5 kWh                                | 17.3 kWh           |

Labor costs include management overhead, vacation, sick leave and labor time for light maintenance of equipment and site.

The total cost estimates for Beltsville Aerated Pile Method are shown in Table 5.

Table 5

TOTAL COSTS FOR BARC SYSTEM

| <u>Item</u>                | <u>Dollars per Dry Ton</u> |                | <u>Percent of Annual Costs</u> |                |
|----------------------------|----------------------------|----------------|--------------------------------|----------------|
|                            | <u>50 tons</u>             | <u>10 tons</u> | <u>50 tons</u>                 | <u>10 tons</u> |
| Operating Costs            | 28.36                      | 41.37          | 79                             | 81             |
| Site Development           | 3.23                       | 4.00           | 9                              | 8              |
| Equipment                  | 3.75                       | 5.26           | 10                             | 10             |
| Land, excluding facilities | 0.63                       | 0.63           | 2                              | 1              |
| <b>TOTAL</b>               | <b>35.97</b>               | <b>51.26</b>   | <b>100</b>                     | <b>100</b>     |



Labor is the greatest operating expense and represents half of all the operating expenses. Labor costs were based on \$6 per hour with 5 weeks of sick and vacation time and 6% for the employer's share of social security plus \$400 per worker for health care.

The estimates for the costs of the BARC composting system by Epstein and his group (Colacicco et al., 1977) are higher than the 1974 estimated costs of the equipment and energy intensive composting operation of the Los Angeles County Sanitation Districts (LACSD). It is estimated that the BARC system costs per dry ton of sludge for a 50 tons/day plant is \$38.50. The Districts' estimate was \$2.02 per wet ton or \$8.80 per dry ton (assuming 23% moisture) for operating, maintenance, and capital recovery for equipment and structures; land costs were not included. Current estimates by Gunnerson (personal communication) are as follows:

Table 6

TOTAL COSTS FOR LACSD SYSTEM

170 Tons/day

|                           |                |
|---------------------------|----------------|
| Capital (including land)  | \$13.20        |
| Operation and Maintenance | <u>14.30</u>   |
| Total                     | <u>\$27.50</u> |

Composting is more economical than incineration, wet oxidation, pyrolysis or other advanced technologies. Since the BARC method is more labor-intensive, it is considered more suitable and more economical in developing countries than the highly mechanized windrow-turning operating as practiced in Los Angeles.

b. Preliminary Estimates of Costs of Composting 10 Dry Tons of Night Soil per Day

1. Site size: 0.8 to 1.2 ha. The lower figure is for a site which does not need runoff collection or administrative areas. Site cost will depend on land values. For example, at \$25,000/ha the costs would range from \$19,200 to \$30,000 for a compost site.

2. Site development: This will depend on climate, existing soil conditions and facilities present. The availability of power and water would reduce site development costs. Where electricity is not available, a small portable generator would be required to supply electricity to the air blowers. A concrete pad would be most expensive followed by asphalt and crushed rock. Approximately half the site should have a hard surface unless local conditions allow for operations on an unpaved area. It is estimated that equipment and site development costs would vary between \$100,000 and \$200,000.

3. Estimated annual operating costs per 10 dry tons per day capacity (excluding labor):

|                                       |          |
|---------------------------------------|----------|
| a. metal pipe recoverable             | \$ 5,000 |
| or (plastic pipe, non-recoverable) to | 12,000   |
| b. power - fuel, electricity          | 10,000   |
| c. equipment maintenance              | 10,000   |
| d. miscellaneous supplies, etc.       | 5,000    |

Total: \$30,000 - \$37,000

4. Labor. Labor cost will depend on the remuneration in each country. The following is an estimate of the minimum labor force required to compost 10 dry tons of night soil per day.

- 1 foreman
- 2 equipment operators for front-end loaders
- 1 tractor operator for mixing
- 2 general hands for laying out pipe and general work
- 1 screen operator if screening is to be done

Based on these rough estimates, it will be possible to develop preliminary designs for demonstration night-soil composting plants in several developing countries. However, real cost figures can be developed only after demonstration-pilot studies have been carried out in several appropriate developing countries.

c. Problems of Marketing

Julius (1977) has studied the economic aspects of low-cost waste disposal and reuse in developing countries and suggests that urban wastes such a night-soil compost may behave according to the economic theory of "inferior goods." This theory states that contrary to normal demand curves which tend to go up with increasing income, the demand for "inferior goods" decrease. As an example, she cites the historical data from Ireland which shows that potato demand decreases when consumer income was high since other higher-priced carbohydrates were purchased instead.

She shows that for selected cases in Taiwan, Japan, and Korea night-soil demand by farmers decreased as farm income increased and alternative higher costing chemical fertilizer could be purchased.

This situation may have certain far-reaching policy implications as to the suitability of "appropriate low-cost technology" for waste disposal and reuse in developing countries. Even if "appropriate" technology is developed, the problem of a decreasing demand or even difficulties in ultimate disposal at no charge may plague the economics of the system as living standards increase.

Julius suggests that no less important than developing and testing new low-cost waste disposal and reuse technology is the need to develop educational programs stressing the long-term economic and ecological benefits of safe and hygienic waste reuse. Such an effort, if successful, may lead to organic waste reuse being perceived as a socially desirable objective, the demand for which could actually "increase as their price goes up."

The success of such a program would depend on successful demonstration of the agricultural benefits derived from night-soil compost reuse. Such agricultural research and extension work should be seen as an essential part of the pilot study program of night-soil composting since demand for the product may provide the key to its long-term social acceptability and economic success.

In any event, night-soil treatment and reuse systems should not be seen as a profit-making venture but rather as a way of solving a serious sanitary problem in the least expensive manner consistent with good hygienic and environmental practices and norms.

#### 8. Research and Pilot Study Needs

As stated previously, it is concluded that the BARC night-soil composting system is suitable for developing countries. Further research and pilot studies are required to establish the suitability of the process. At the moment there is only one night-soil composting plant operating according to the BARC system from which direct information can be gained as to the efficacy of the process from a public health point of view and from which the engineering parameters and design criteria for the development of full-scale plants in developing countries can be derived. That night-soil composting plant is operated by the National Capital Parks Service at Dargon in Washington, D.C. To date, only limited scientific monitoring of the above plant has been carried out although from the data available to date there is a good indication that the system works, is nuisance free, and effectively inactivates pathogens in the final composted night-soil, sawdust, wood chip mixture.

It is essential to obtain the following information before proceeding with the design of full-scale night-soil composting plants using the BARC system in developing countries.

##### a. Characteristics of Night Soil

Representative data should be collected on the chemical and physical characteristics of night soil in different countries of the world following different practices of nutrition and personal hygiene. Chemical tests which should be carried out include total and volatile solids, carbon, pH, Kjeldahl nitrogen, ammonia, zinc, cadmium, nickel, and lead. Physical characteristics that should be determined include moisture content, total volume per capita, density and seasonal variations. In addition, information could be obtained on the concentration of several key pathogens, such as salmonella, Ascaris eggs, hookworm eggs, and enteric viruses might be assayed as well.

b. Bulking Materials

In each site selected for study a survey has to be made of the availability of appropriate bulking materials since the BARC process required the addition of bulking materials both to absorb the moisture of the night soil, provide additional carbon, and to provide the pile with an open structure to enable effective aeration of the static compost pile. The availability of such materials as rice husks, straw, wood chips, sawdust, peanut hulls, tin trash, coconut shells, and any other organic waste materials which might be appropriate for the composting process should be studied. The C/N ratio of the materials should be determined as well as their water-holding capacity and compostability.

c. Environmental Parameters

The effect of environmental parameters on composting operations should be determined including such factors as daily precipitation, temperature range, relative humidity, and soil conditions.

d. Engineering and Operating Parameters

Key engineering and operating parameters to be determined include sources and quantities of night soil and other wastes to be composted, land areas utilized, drainage requirements, cost of materials, labor and other operating expenses, temperature profiles within the pile, oxygen levels within the pile under various operating conditions, volatile solids destruction and percent moisture during composting, and the availability of infrastructure for technical operation and maintenance of equipment.

e. Evaluation of the Final Compost from a Microbiological Point of View

A series of samples from every composted batch should be analyzed for pathogenic bacteria and parasites, as well as for a number of key indicator organisms, such as coliforms and fecal coli bacteria. Assays for enteroviruses should be carried out if facilities are available.

f. Quality of the Compost

Standard assays for the chemical composition of the final compost should include C/N ratio, and the percent nitrogen, phosphorous and potassium. Where possible agricultural tests and demonstrations with the final compost should be carried out to determine its suitability as a soil conditioner and fertilizer. Market surveys should be carried out to determine the possibility for the sale and distribution of the final product in the local economy.

The pilot studies should be carried out in developing countries with varying climatic conditions so as to include the full spectra of possible conditions to be faced by night-soil composting operations, including cold wet climates, cold dry climates, and hot tropical climates. The cities selected for night-soil composting pilot plant demonstrations should be selected based on the availability of an existing night-soil collection and

disposal system which is operating in a fairly effective manner so as to assure the supply of fresh night soil for the composting operation. Another criterion in the selection of the city is the availability of a principal investigator who has the appropriate technological and scientific background to organize and coordinate a project of this type. Availability of chemical and microbiological laboratories, either at a university or a governmental department, is essential. The analytical tests, both chemical and microbiological, listed above are the optimum desirable tests that should be carried out where facilities are available. However, it will be possible to carry out studies with a somewhat reduced schedule of testing if it is possible to obtain the other required services.

In order to fully develop design criteria for a variety of environmental parameters, a number of pilot projects should be developed in such countries as India, Korea, Taiwan, Indonesia, Singapore and Nigeria. It might be particularly feasible to conduct such studies in United Nations supervised refugee camps, such as those in India, Cyprus, Israel and Jordan. Supervisory, scientific and technical personnel at such camps may be available. The cooperation of the local camp and government authorities could be assured through United Nations channels. Another possible site would be at one of the Oxfam sanitation unit locations operating successfully in Bangladesh.

The above mentioned research and demonstration pilot projects carried out in the developing countries can provide essential information required for furthering the goals of the appropriate technology research project. However, it will take considerable time to organize the scientific and technical infrastructure required in any of the above countries. In order to gain vital information concerning the BARC composting system of night soil in the shortest possible time, serious consideration may be given to the possibility of finding ways of supporting a more detailed scientific monitoring and evaluation of the night soil composting plant carried out by the National Park Service in Washington, D.C., using night soil obtained from the park latrine system. The advantages of this project are that it is already operating with the total normal operating expenditure covered by the Park Department itself. The availability of scientific and technical personnel in the vicinity makes it possible to initiate the scientific studies required in the shortest possible time. Preliminary discussions with Mr. J. Patterson, research agronomist of the National Capital Park System in Washington, indicate that he and his organization would be pleased to cooperate in such a study if the additional funds required to carry out the microbiological and chemical tests were made available.

Another possible site for a research-pilot study that could be quickly organized would be at the University of Texas at San Antonio where Dr. Bernard P. Sagik and his group have developed considerable expertise

in the health aspects of land disposal of sewage sludge and are interested in the possibility of initiating a BARC composting study with night soil from portable latrines used extensively at construction sites in the area. The workers are mainly low-income groups of Mexican origin with known high endemic infestations of intestinal parasites. A study at that location would provide valuable information on the inactivation of such parasites by the BARC system by a high-level scientific team uniquely qualified for such a study. They could also do virus work which might not be possible in most developing countries.

In conclusion, an extensive program of research-pilot studies is needed to determine the full range of technological, public health, and economic effectiveness of the BARC night-soil composting system in several developing countries before long-term municipal-scale programs are initiated.

9. Bibliography

- Bhaskaran, T.R., Sampathkumaran, M.A., and Radhukrishnan (1956). Studies on the effect of sewage treatment processes on the survival of intestinal parasites, Ind. Jour. Med. Res., 44:163-180.
- Burge, W.D., and Cramer, W.N. (1974). Destruction of pathogens by composting sewage sludge--progress report, Aug. 1, 1973-April 1, 1974. Cooperative Project: 12-14-1101, ARS-USDA internal report not for publication, 46 pp.
- Burge, W.D., Cramer, W.N., and Epstein, E. (1976). Pathogens in sewage sludge and sludge compost, Proc. A.S.C.E. San. Eng. Div., Dec. paper 76-2559.
- Ch'ou, H.T., Huel-lan, C., Lien-yin, H., and Hsin-Chin, W. (1959). Achievements in the fight against parasitic diseases in New China, Chinese Med. Jour. 79:493-520 (December 1959).
- Cliver, D.O. (1976). Surface application of municipal sludges, Proc. of Conf. on Virus Aspects of Applying Municipal Waste to Land, Ed Baldwin, Davidson and Gerbe, Univ. of Florida, Gainesville, 77-81.
- Colacicco, D., Epstein, E., Wilson, G.V., Parr, J.F., and Christensen, L.A. (1977). Cost of sludge composting, ARS-USDA, ARS-NE-79, February 1977, 18 pp.
- County Sanitation Districts of Los Angeles County (1975). Summary report on compost-air drying operations at Joint Water Pollution Control Plant, County Sanitation Districts of Los Angeles County, 23 pp.
- Craig and Faust (1970). Clinical parasitology, edited by E.C. Faust, P.F. Russel, and R.G. Jung. Lea and Febiger, Philadelphia.
- Cram, E. (1943). The effect of various treatment processes on the survival of helminth ova and protozoan cysts in sewage, Sewage Works Jour., 15:1119-1138.
- Dept. of Environmental Health, Chinese Academy of Medical Sciences, Peking (1975). Sanitary effects of urban garbage and night-soil composting, Chinese Med. Jour., 1(6), 407-412.
- Epstein, E., Wilson, G.B., Burge, W.D., Mullen, D.C. and Enkiri, N.K. (1976). A forced aeration system for composting wastewater sludge, Jour. of Water Pol. Control Fed. 48:688-694.
- Epstein, E., Taylor, J.M. and Change, R.L. (1976). Effect of sewage sludge and sludge compost applied to soil and some soil physical and chemical properties, Jour. Environ. Qual. 5:422-426.

- Epstein, E., Parr, J.F., and Burge, W.D. (1977). Health aspects of land application of sewage sludge and sludge compost, Presented at National Conf. on Hazardous Waste Management, San Francisco, February 3, 1977, Dept. of Health, State of California (mimeo, 33 pp.).
- Food and Agriculture Organization (1975). Organic material as fertilizers, Soils Bull. 27, F.A.O., Rome.
- Gillis, E.C. (1946), Farm and Forest 2:92.
- Gotaas, H.B. (1953). Reclamation of municipal refuse by composting, University of California, Berkeley, Sanitary Eng. Research Laboratory, Tech. Bull. no. 9, Series 37.
- Gottas, H.B. (1956). Composting, WHO Monograph No. 31, Geneva.
- Gray, K.R., Sherman, K., and Biddlestone, A.J. (1971). A review of composting, Part I, Process Biochemistry, June 1971; Part 2, October 1971; Part 3, October 1973.
- Gunnerson, C.G. (1972). Composting in Resource Recovery in Industrial Approaches to Urban Problems, pp. 177-185, Prueger Publishers, New York.
- Hamlin, E.J. (1949). Surveyor, London, 108:399.
- Hanks, T.G. (1967). Solid waste-disease relationships - a literature survey; U. S. Dept. of Health, Education and Welfare, Public Health Service Publication No. 999 UH-6 Monograph, 179 pp.
- Hart, S.A. (1968). Solid waste management/composting: European activity and American potential. U.S. Dept. of Health, Education and Welfare, Public Health Service Publication No. 1826.
- Haug, R.T., Tortorici, L.D., and Raksit, S.K. (1977). LA/OMA Project: Sludge processing and disposal. Regional Wastewater Solids Management Program, Los Angeles/Orange County Metropolitan Area, 236 pp.
- Hawkins, P. and Feachem, R. (1977). The environmental control of certain helminth (worm) infections, Proc. Conf. on Sanitation in Developing Countries Today, Oxfam, Oxford, U.K., 29 pp.
- Hays, B.D. (1977). Potential for parasitic disease transmission with land application of sewage plant effluents and sludges, Water Research.
- Hogg, E.S. (1950). A preliminary study of ova and cysts in cynda digested sludge, J. Proc. Inst. Sewage Purification, part 1, South African Branch.
- Howard, A. and Wad, Y.D. (1931). The Waste Products of Agriculture. Oxford University Press, London.



- Julius, DeAnne (1977). Urban waste as an economic good (bad?), Proc. Conf. on Sanitation in Developing Countries Today, Oxfam, Oxford, U.K. 6 pp.
- Katayama, Y. (1955). Sanitary treatment of human excreta by heating process, Japanese Jour. Nations Health 24:1-12 (English Summary).
- Keller, P. (1951). Sterilization of sewage sludges, Public Health, Johannesburg, 15:11-17.
- Keller, P. (1951). Sterilization of sewage sludges, Part 1, J. Proc. Inst. Sewage Purification, 92-99.
- Kozai, I. (1964). Re-estimation of sodium nitrate as an ovicide used in night soil, Japanese J. Parasit. 11 (5) 400-410 (English Summary).
- Krige, P.R. (1964). A Survey of the Pathogenic Organisms and Helminth Ova in Composts and Sewage Sludge. J. Inst. Sewage Purification, 215-220.
- Kubo, T., and Sugiki, A. (1977). Wastewater reuse in Japan in Water Renovation and Reuse; H. Shuval, Ed., 331-351.
- Kumph, E.H.W., Mass, K., and Straub, H. (1977). Muls and Abfall Besertigung, Erich Schmidt Verlag, Berlin.
- Los Angeles County Sanitation Districts (1976). Pathogen inactivation during sludge composting - status report, 21 pp (mimeo monograph unpublished).
- Malviya, H.M. (1964). Temperature-tolerance of viable ova of Ascaris lumbricoides, Env. Health (India) 6:63-64.
- Mann, H.T. (1976). Sanitation without sewers, Overseas Building Notes No. 168, June 1976, 6 pp.
- McGarry, M.G. (1976). Domestic wastes as an economic resource, Biogas and fish culture in Water, Wastes and Health in Hot Climates, R. Feachem, M. McGarry and D. Mara, Eds., John Wiley and Sons, Chichester and New York, 347-364.
- McGarry, M.G. (1976). The Taboo Resource: The use of human excreta in Chinese agriculture, The Ecologist 6, 4 pp.
- Moore, B.E., Sagik, B.P., and Sorber, C.A. (1977). An assessment of potential health risks associated with land disposal of residual sludges, Proc. 3rd Nat'l. Conf. on Sludge Management, Disposal and Utilization, Information Transfer, Inc., Rockville, MD.
- Office of Solid Waste Management Programs (1971). Composting of municipal wastes in the United States, U.S. Environmental Protection Agency Publication No. SW-47.

- Patterson, J.C. (1977). Urban wastes for soil rejuvenation, Trends in National Resources Management (National Park Service) April-June 1977, 20-22.
- Peel, C. (1973). The public health and economic aspects of composting night soil with municipal refuse in tropical Africa, Proc. 3rd Int'l. Conf. on Environmental Health Eng. in Hot Climates and Developing Countries - Planning for Water and Wastes in Hot Countries, John Pickford, Ed. Loughborough University of Technology, Loughborough, U.K.
- Petrik, M. (1954). Utilization of night soil, sewage and sewage sludge in agriculture. Bull. World Health Organization 10:207-228.
- Pineo, C.S., and Subrahmanyam, D.V. (1975). Community water supply and excreta disposal situation in developing countries - a commentary, World Health Organization, Geneva, 39 pp.
- Reyes, W.L., Kruse, C.W., Batson, M.St.C. (1963). The effect of aerobic and anaerobic digestion on eggs of Ascaris lumbricoides var. suum in night soil, Am. J. Trop. Med. Hyg. 12:46-55.
- Rudolfs, W., Falk, L.L., and Ragotzkie, R.A. (1950). Literature review on the occurrence and survival of enteric, pathogenic and related organisms in soil, water sewage, and sludges, and on vegetation, II Animal parasites. Sew. and Ind. Wastes 22:1417-1427, and III Field Studies on Ascaris eggs, Sew. and Ind. Wastes 23:656-660.
- Sandia Laboratories (1976). Progress report: Beneficial uses program period ending December 31, 1976. Sandia Laboratories, Albuquerque, New Mexico, SAND77-0426.
- Sanitation Districts of Los Angeles County (1977). Pomona virus study - final report, Monograph, 230 pp.
- Scharff, J.W. (1940). Composting: The safe conversion of village refuse and night soil into valuable manure. J. of the Malayan Branch, British Med. Assoc. 4:126-135.
- Scott, J.C. (1952). Health and agriculture in China. A fundamental approach to some of the problems of world hunger, London.
- Selna, M.W., and Smith, D.L. (1977). Pathogen inactivation during sludge composting; unpublished report, Los Angeles County Sanitation Districts.
- Shuval, H.I. (1977). The use of wastewater for irrigation with special reference to enteric pathogenic protozoans and helminths, Proc. Conf. on Sanitation in Developing Countries, Oxfam, Oxford, U.K.

- Smith, D., and Selna, M.W. (1976-1977). Pathogen inactivation during sludge composting, internal reports, County Sanitation Districts of Los Angeles.
- Snell, J.R. (1943). Sew. Wks. J. 15:679
- Stone, G.I., Wiles, C.C., and Clemons, C. (1976). Composting at Johnson City, final report on joint USEPA-TVA Composting Project 1967-1971, U.S. Environmental Protection Agency EPA/530/SW - 31r. 2, 336 pp.
- Stone, R. (1949). Sewage Wks. J., 19:441.
- Streefland, P.H. (1977). The social organization of night-soil collection in selected Asian cities, Proc. Conf. on Sanitation in Developing Countries Today, Oxfam, Oxford, U.K., 10 pp.
- Szechwan Research Institute of Antiparasitic Diseases (1974). Digestion of night soil for destruction of parasite ova: a report of investigation and experimental observation, Chinese Med. J. 2:31.
- Wiley, B.B., and Westerberg, S.C. (1969). Survival of human pathogens in composted sewage, Appl. Microbiology 18:994-1001.
- Wiley, J.S. (1962). Pathogen survival in composting municipal wastes, J. Water Poll. Contr. Fed. 34:80-90
- Wilson, F.B. (1948). E. Afr. Agriculture Jour. 14:2.
- World Health Organization (1954). Report of the expert committee on environmental sanitation, World Health Organization Tech. Rep. Ser. 77.
- World Health Organization (1974). Disposal of community wastewater. WHO Tech. Rep. Ser. 277, Geneva.
- World Health Organization (1978). Compost. An annotated bibliography on compost, compost quality, and composting, 1971-1977. WHO International Reference Centre for Wastes Disposal, Zurich.
- Wright, W.H., Cram, E.B., and Nolan, M.D. (1942). Preliminary observations on the effect of sewage treatment processes on the ova and cysts of intestinal parasites, Sew. Wks. J. 14:1274-1280.
- Yanko, W.A., Dahlgren, J.A., Easley, R.C., Glass, J.S., Van Sluis, R.J. (1976). Survival of pathogenic and indicator microorganisms in sewage sludge amended agricultural soils: Summer growing season 1976, Internal report, County Sanitation Districts of Los Angeles County, 22 pp.
- Yanko, W.A., Glass, J.S., and Sluis, R.J. (1977). Analysis of sludges for indicator and pathogenic microorganisms, Proc. CWPCA Annual Conference at Anaheim, CA, April 14-16, 1977, 8-12 (mimeo).

TECHNOLOGICAL ASPECTS OF  
THE BARC COMPOSTING SYSTEM AS RELATED TO COMPOSTING NIGHT SOIL:

by

Eliot Epstein, Ph D.

I. INTRODUCTION

The Beltsville Aerated Pile Composting System was developed as a low-cost, low-energy, sewage sludge processing system. The major advantages to this system are:

1. Composting raw sludge, i.e. primary or secondary or night soil, eliminates the need for further processing, e.g. digestion, wet oxidation, heat treatment, or other technology.
2. The microbial decomposition of sludge or night soil during composting alleviates malodors and produces a stable, humus-like, organic material.
3. Heat produced during composting effectively destroys many known human pathogens.
4. The system is not capital intensive and does not require the technical and engineering expertise required for such systems as incineration or heat drying.
5. Energy inputs for operation are extremely low.
6. The product can be utilized as a fertilizer and soil conditioner.

The major disadvantages or limitations to composting are:

1. It generally requires more land than other treatment systems; and,
2. More labor intensive than many of the other systems.

## Process Design

### I. Collection and Transportation

The present Beltsville Aerated Pile method utilizes dewatered raw (primary combined with some secondary) sewage sludge for composting. This sludge contains 78% water and 48% volatile solids. The sludge is transported to the compost site in 10 ton sealed trucks. Experiments with liquid sludge (98% water, 66% volatile solids) have been carried out at Beltsville. Liquid sludge was transported in tandem cement vehicles. Table 1 provides data on the composition of the raw sludge from the Blue Plains waste water treatment plant in Washington D. C.

Data from A. Singh <sup>1/</sup> (1975) indicate that night soil from India has a moisture content of 85% to 90% and volatile solids of 80 to 88%. The U.S. Department of Interior, National Capital Park Service has been composting night soil (pumping from portable sanitary outhouses) using the BARC system. The night soil is pumped out of the outhouses (sanitary john), capacity 50 to 75 gal (190 to 280 liters), up to twice a week in the summer and once every two weeks in the winter. The tank which pumps out the night soil, has a 500 gal. (1450 liter) capacity. Pradt (1971) <sup>2/</sup> indicates that there are substantial differences between night soil and fresh sewage sludge. Night soil has a pH of 8.5 and high concentration of ammonia, chloride and volatile solids. It is not believed that these should cause any problems in composting. Data from Beltsville show that composting can take place over a large pH range of 5.5 to 12. Neither the ammonia nor chloride are known to present problems.

### II. The Beltsville Aerated Pile Method (BARC)

The process consists of the following steps:

1. Mixing - sludge (liquid or dewatered) is mixed with a bulking material.
2. The Beltsville Aerated Pile construction and maintenance.
3. Screening - recovery of bulking material for recycling (optional).
4. Curing and storage.
5. Distribution.

---

<sup>1/</sup> Singh. A. Soils Bull. 27, p. 19-30, FAO, Rome (1975).

<sup>2/</sup> Pradt. L. (1971) Some recent developments in night soil treatment  
Water Res. 5: 50-21.

**Table 1. Chemical Analysis of Raw Dewatered Sewage Sludge from the Blue Plains Wastewater Treatment Plant, Washington, D. C., and the Raw Sludge Compost Produced at the U. S. Department of Agriculture's Composting Research Facility at Beltsville, Maryland.**

| <u>Component</u>    | <u>Raw Sludge</u> | <u>Raw Sludge Compost</u> |
|---------------------|-------------------|---------------------------|
| Organic Carbon      | 31%               | 23%                       |
| Water               | 78%               | 35-58%                    |
| Potassium           | 0.19%             | 0.16%                     |
| Phosphorus          | 1.46%             | 1.0%                      |
| Calcium             | 1.39%             | 1.42%                     |
| Magnesium           | 0.41%             | 0.40%                     |
| Total Nitrogen      | 3.8%              | 1.6%                      |
| Ammonia             | 1,540 ppm         | 235 ppm                   |
| Nitrate and Nitrite | 1 ppm             | 3 ppm                     |
| Zinc                | 980 ppm           | 770 ppm                   |
| Copper              | 420 ppm           | 300 ppm                   |
| Nickel              | 87 ppm            | 55 ppm                    |
| Cadmium             | 10 ppm            | 8 ppm                     |
| Lead                | 420 ppm           | 290 ppm                   |

6. Monitoring and management 1/

7. Health aspects of sludge composting 1/

1/ Operational and research quality control are based on procedures in Methods of Soil Analysis, Agronomy Monograph No. 9, American Society of Agronomy, Madison, WI. (1965) and in Standard Methods for the Examination of Water and Wastewater, 14th Ed. American Public Health Association, Washington, D.C. (1976).

Figure 1 is a flow diagram illustrating the process for dewatered (22% solids) sewage sludge. Modification of the process has been used for liquid sludge or night soil as illustrated in figure 2.

### Mixing

1. Two volumes of woodchips maximum dimensions of 4 to 5 cm, are mixed with one volume of sludge. Other bulking materials which will be discussed later may require different ratios. The final mix should not contain lumps of sludge larger than 7.5 cm in diameter. Mixing can be achieved by using a front-end loader, farm tractor and rototiller, commercial mixers, pug mills or rotary drums. The selection of equipment will depend on the size of operation, location of composting site, climatic conditions and availability of labor. It is essential that the bulking material be kept as dry as possible so that the final mix is at approximately 60% moisture without using excessive amounts of bulking materials. During mixing odors can be produced causing excessive nuisance. Where large volumes of materials are to be mixed, it would be preferable to mix in an enclosed stationary mixing facility. In the case of night soil, mixing in a closed system may also be hygienically preferable.

### PROPOSED SYSTEM FOR COMPOSTING NIGHT SOIL

The following sequence and operations is recommended for composting night soil (Figure 2).

1. Delivery of night soil by tank trucks to a composting site.
2. Transferring the night soil into a mixing drum or storage tank. A concrete mixer (tandem type) is ideally suited for a pilot study.
3. Bulking materials are then added. A fine, absorbent bulking material such as sawdust can be used initially to absorb excess moisture. Finished compost itself can also be used. The mix (concrete consistency) can then be applied onto a bed of coarse material such as woodchips, or the woodchips added to the previous mix in the mixer.
4. If the mixer is needed for incoming night soil, then the first mix can be applied to a bed of woodchips and mixed with a rototiller attached to a farm tractor. Mixing can also be accomplished with a front-end loader.
5. The final mix can then be used to build the aerated pile as described in the Beltsville Aerated Pile Method.

Figure 1. Flow Diagram for Composting Operation

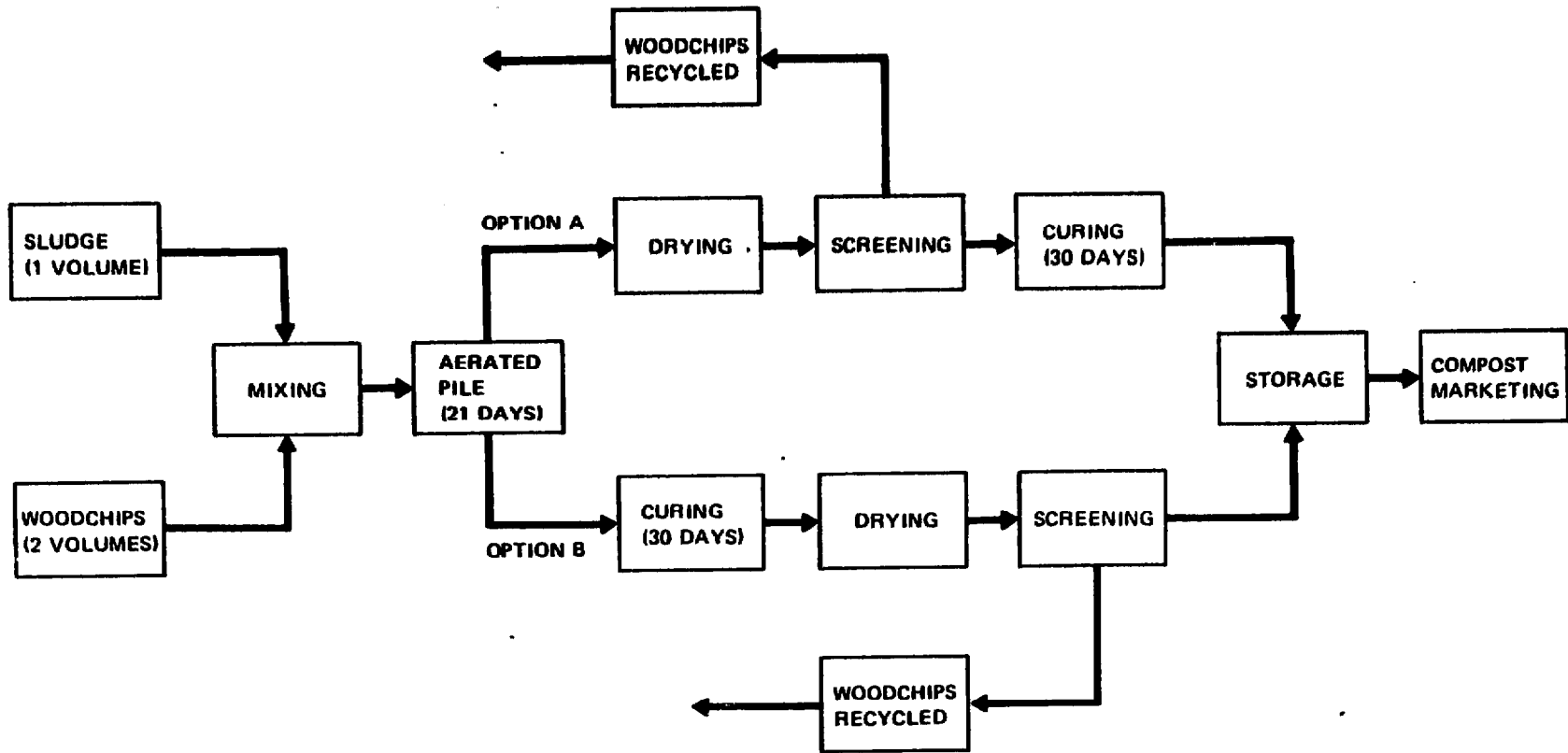
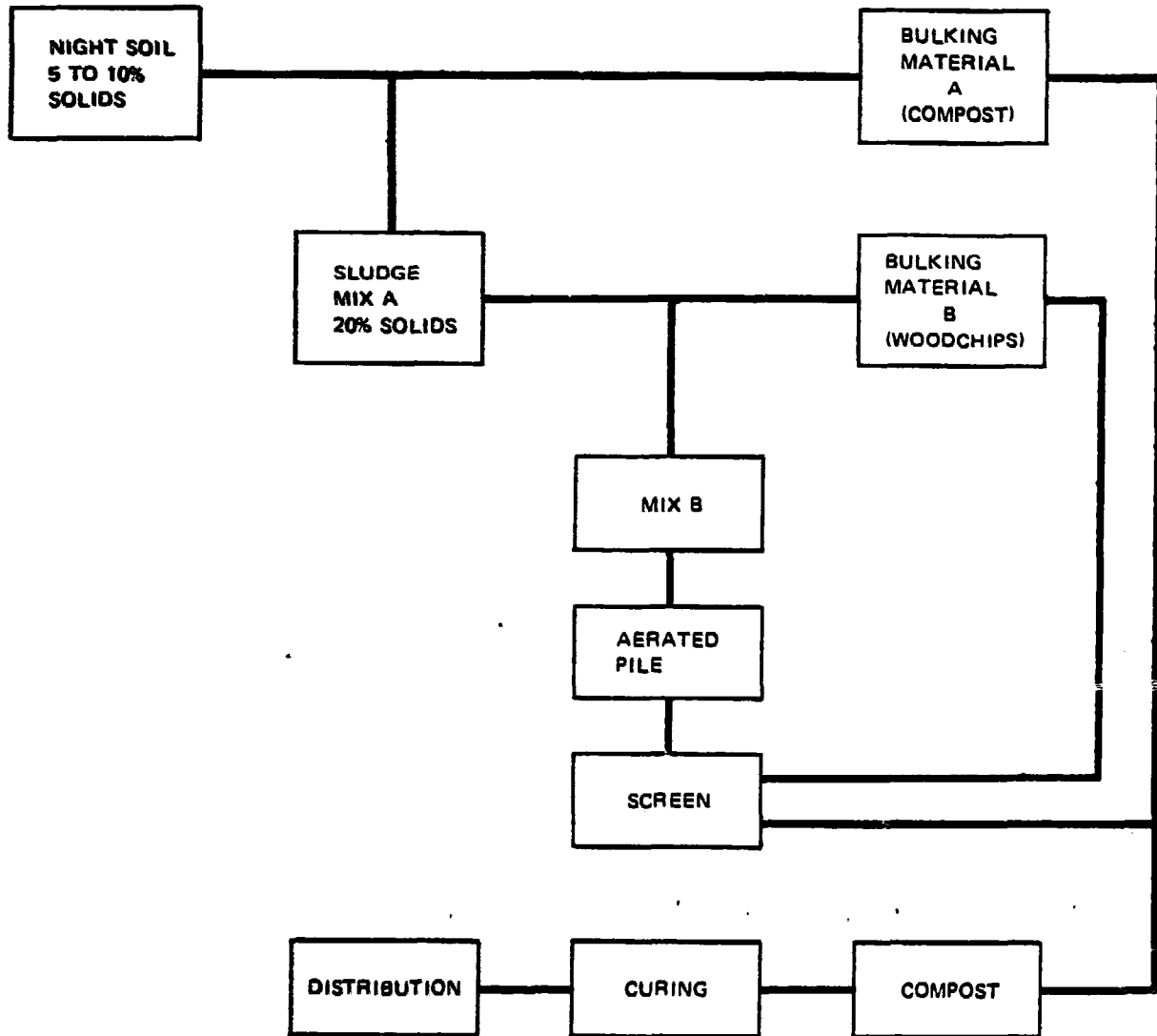



Figure 2. Flow Diagram for Composting Night Soil or Liquid Sludge



### Bulking Materials

The purpose of the bulking materials is as follows:

- a. Reduce the moisture content of the sewage sludge or night soil to 50 to 60 percent.
- b. Provide structure or porosity for air movement through the mixture. The Beltsville Aerated Pile system is an aerobic process requiring oxygen.
- c. Provide carbon to raise the Carbon to Nitrogen (C/N) ratio to approximately 20-30 to 1. The C/N ratio of sewage sludge is in the range of 9-15 to 1. Raising the C/N ratio reduces the loss of nitrogen as ammonia. The addition of carbon as a bulking material ensures the conversion of nitrogen into organic constituents of the biomass.

Various materials can be used as bulking materials e.g. wood chips, sawdust, wood shavings, peanut hulls, corn cobs, straw, rice hulls, cotton gin trash, leaves, shredded bark, shredded paper and air-classified fractions (mainly paper) obtained from solid waste recovery plants, etc.

## 2. The Beltsville Aerated Pile

### A. The Aerated Pile

A three-dimensional schematic diagram of the Beltsville Aerated Pile Method for composting sewage sludge is shown in Figure 3. In their simplest form the individual, stationary, aerated piles are constructed as follows:

- a. A loop of 4-inch diameter (10 cm) perforated plastic pipe is placed on the composting pad, oriented lengthwise, and symmetrically under what will become the ridge of the pile. Perforated steel pipe can also be used and later removed for reuse. The perforated pipe should not extend under the end slopes of the pile because excessive amounts of air may be pulled through the sides, causing localized zones (i.e. "coldspots") that do not reach the thermophilic range. The pipe should be placed at least 8-10 ft (2.5 to 3 m) from the ends of the pile.
- b. A 6 to 8 inch (15 to 20 cm) layer of wood chips or other bulking material is placed over the pipe and the area to be occupied by the pile. This layer comprises the pile base and facilitates the movement and distribution of air during composting. The base material also absorbs excess moisture that may condense and leach from the pile.

**FIGURE 3**  
**ELEMENTS OF THE BELTSVILLE AERATED**  
**RAPID COMPOSTING SYSTEM**  
**(EPSTEIN ET AL. 1976)**

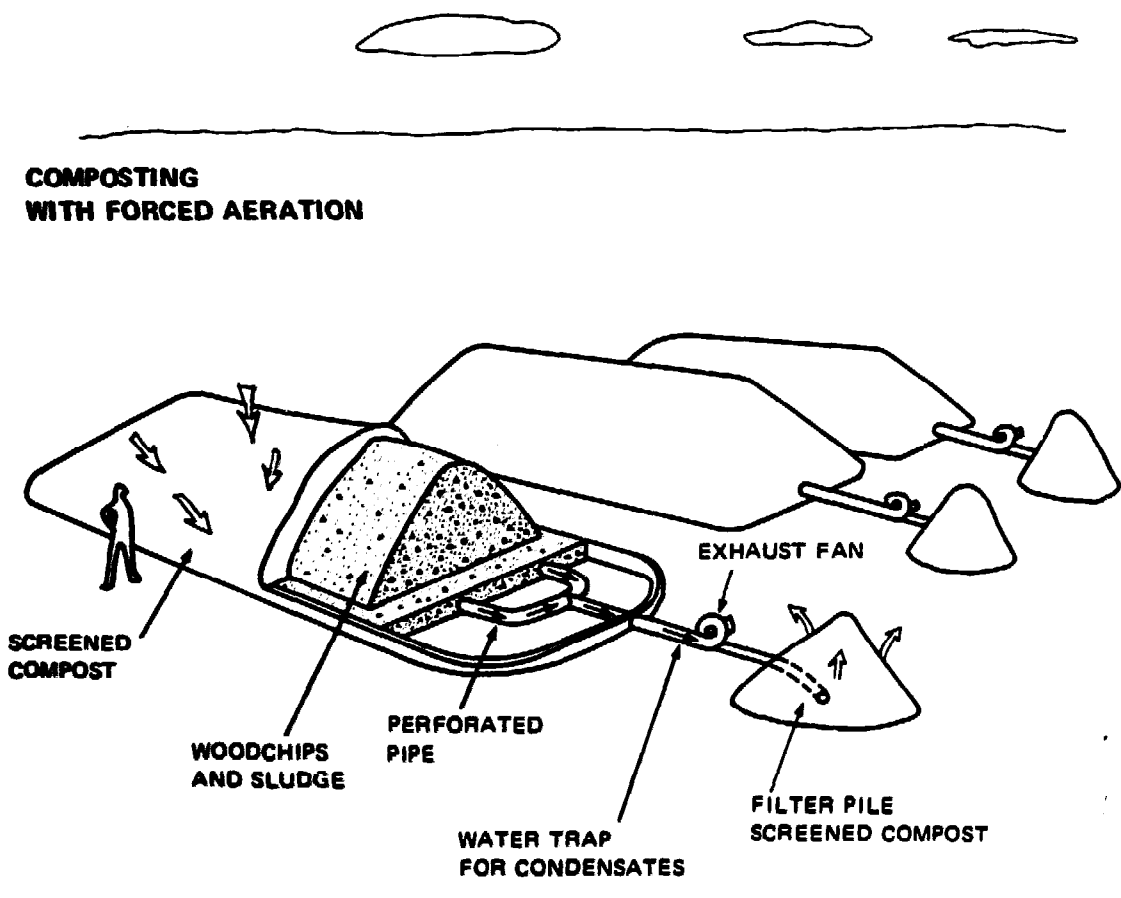

- c. The mixture of sludge and wood chips is then placed loosely upon the prepared base (with a front-end loader or conveyor system) to form a pile, with a triangular cross-section, 15 feet wide (5 m) and 7.5 feet high (2.5 m).
- d. The pile is completely covered with a 12-inch (30 cm) layer (often referred to as the "blanket") of cured, screened compost. The blanket layer provides insulation and prevents the escape of malodorous gases during composting. If finished compost is not available, as would be the case for the first piles of a new operation, the bulking material itself can be used for this purpose. However, the blanket thickness may have to be increased to achieve the same degree of insulation and odor control as obtained with cured compost.
- e. During construction of the pile base, the perforated pipe is connected to a section of solid plastic pipe which extends beyond the pile base. The solid pipe is connected to a 1/3-hp blower controlled by a timer. Aerobic composting conditions are maintained by drawing air through the pile intermittently. The exact aeration schedule will depend on pile geometry and the amount of sludge to be composted. For a pile containing up to 80 tons of sludge (20 m x 5 m x 2.5 m), the timing sequence for the blower is 5 minutes on and 15 minutes off. The blower is then turned on and the composting period begins.
- f. The effluent air stream from the compost pile is conducted into a small cone-shaped pile of cured, screened compost approximately 4 feet high (1.3 m) and 8 feet in diameter (2.7 m), where malodorous gases are effectively absorbed. These are commonly referred to as odor filter piles. The moisture content of compost used for this purpose should not exceed 50% because the odor retention capacity tends to decrease at higher moisture levels. A 4-inch (10 cm) base layer of wood chips or other bulking material under the odor filter pile is necessary to minimize back pressures which could cause leakage of malodorous gases around the blower shaft and to absorb excess moisture. Research has shown that the odor filter pile should contain about one cubic yard of screened compost for each 10 wet tons (4 dry tons) of sludge being composted. In the case of new operations, where screened compost is not yet available, some bulking materials or soil (or a mixture thereof) could be used in the filter piles.

Variations in pile shape and size can adapt the process to differences in the rate of sludge production by most treatment plants. The individual pile method described here is suitable for operations ranging from as little as 5 tons of sludge (20% solids) from a single weekly dewatering operation to more than 100 tons per week.

**B. The Extended Aerated Pile**

Another version of the aerated pile is the aerated extended pile. Each day's sludge production is mixed with a bulking material and a pile is constructed which utilizes the slope (lengthwise dimension) of the previous day's pile, thus forming a continuous or extended pile. The extended pile offers certain advantages for larger municipalities on a daily sludge production schedule. For example, the area of the composting pad can be reduced by about 50% as compared with that required to accommodate an equal amount of material in individual piles. Moreover, the amount of blanket material (i.e. screened compost) needed for insulation and odor control, and the amount of bulking material for the pile base are both decreased by 50%.

In constructing an extended pile, the first day's sludge production is placed in an individual pile with triangular cross-section as described earlier. The exception is that only one side and the ends are blanketed. The remaining side is dusted with about an inch (2.5 cm) of screened compost for overnight odor control. On the next day, additional aeration pipe is placed on the pad surface parallel to the dusted side, the pile base is extended, and the sludge-woodchips mixture is placed in such a manner as to form an extended pile. On the second day, the flat top and ends are blanketed with screened compost and the remaining side receives a thin layer of compost as before. The pile is extended each day for 28 days. However, after 21 days the first day's section is removed for either drying and screening or placing in a curing pile. After the removal of seven sections in chronological sequence, there is sufficient space for operating the equipment so that a new extended pile can be started where the old one has been. Thereafter, a section is removed each day from the old pile and a section is added to the new one.

**C. Temperatures Attained During Composting**

The transformation of sludge into compost is essentially complete after 3 weeks in the aerated pile. Microbial decomposition of the volatile organic fraction of the sludge in an aerobic atmosphere soon raises the temperature throughout the pile to above 60°C (140°F), which effectively destroys pathogenic organisms that might cause diseases in human beings. Typical temperatures recorded during the composting of raw sludge by the Beltsville Aerated Pile Method are shown in Figure 4. As can be seen from this figure, temperatures in the pile increase rapidly into the thermophilic range of 80°C (176°F) or higher. Temperatures begin to decrease after about 16 to 18 days, indicating that the more decomposable organic constituents have been utilized by the microflora and that the residual sludge has been stabilized and transformed into compost. Figure 4 also indicates that if piles are constructed properly, neither excessive rainfall nor low ambient temperatures affect the composting process. Studies at Bangor, Maine, Durham, New Hampshire, and Windsor, Canada showed that neither cold weather nor snow affected composting.

FIGURE 4  
TEMPERATURES DURING COMPOSTING OF LAW SLUDGE  
(MAY 1975)  
BARE AT BOTTOM INDICATED RAINFALL EVENTS  
(EPSTEIN EL AL, 1976)

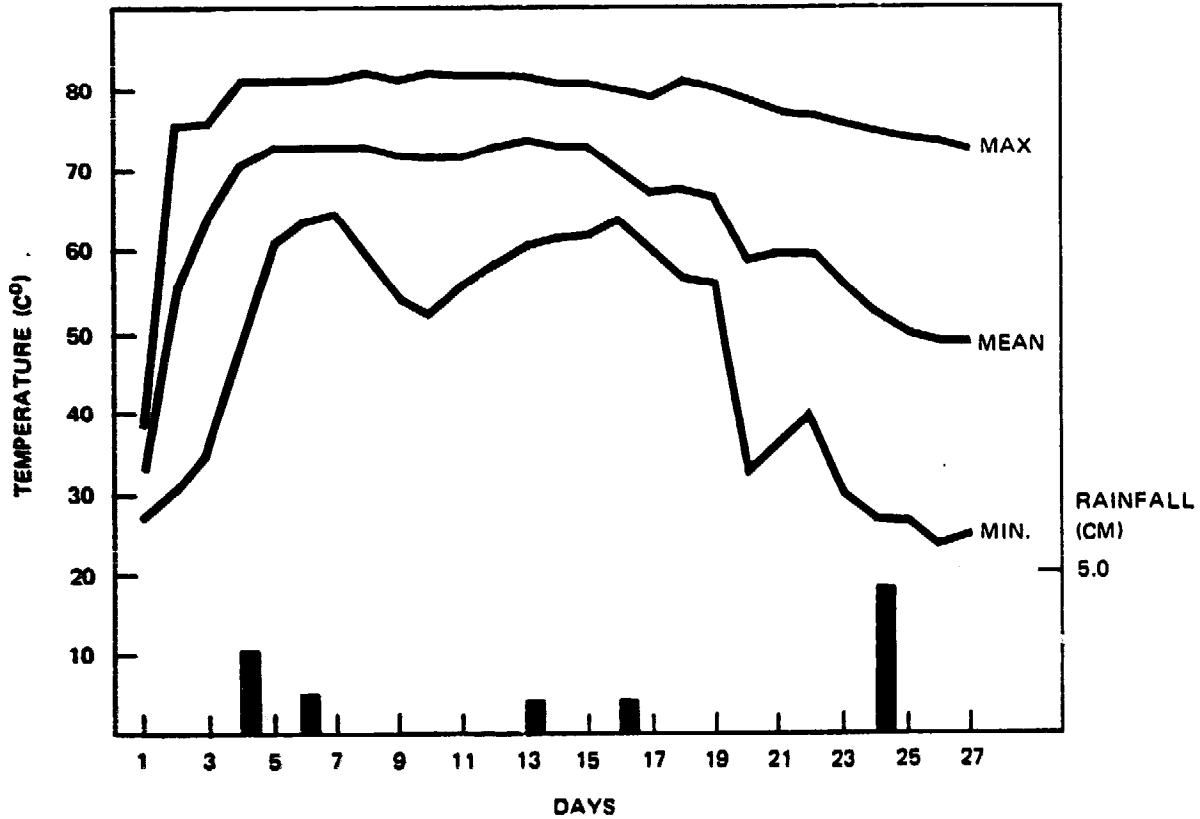

D. Aeration and Oxygen Supply

Centrifugal fans with axial blades are usually the most efficient for developing the necessary suction to move air through the compost piles and into the odor filter piles. A pressure differential of about 5 inches (12.5 cm) (water gauge) across the fan has been adequate when woodchips are used as the bulking material. However, when finer textured materials such as sawdust are used for composting sludge, an increase in pressure differential will be required.

The aeration rate should maintain the oxygen level in the pile between 5 and 15% for rapid decomposition of the sludge and extended thermophilic activity. This level can be achieved with an aeration rate of about 500 cubic feet (14 m<sup>3</sup>) per hour per dry ton of sludge. Research has shown that continuous aeration results in rather large temperature gradients within the pile. A more uniform temperature distribution is obtained by the use of intermittent aeration. Cycles of 20 to 30 minutes, with the fan operating 1/10 to 1/2 of the cycle, have been satisfactory.

Four-inch (10 cm) flexible perforated plastic drain pipe has been used to collect the air under the piles and to deliver it to the odor filter piles. The pipe is damaged beyond reuse when the piles are taken down but since it is relatively inexpensive it is regarded as an expendable item. Rigid steel pipe has also been used and can be pulled lengthwise out of the pile without damage and reused. The pipe spacing for the extended piles should not exceed the pile height. The pipe should be large enough so that friction losses will not cause a pressure differential of more than 15% along the length of the perforated section. Manifolding the outer ends of the pipe will equalize pressure in the event of accidental damage to the pipe.

E. Condensate and Leachate Control

As air moves down through the composting sludge, it is warmed and picks up moisture. Temperatures near the base of the pile are slightly cooler as a result of heat loss to the ground. As the air reaches this area, it is cooled slightly, causing moisture to condense. When enough condensate collects, it will drain from the pile, leaching material from the sludge. Condensation will also collect in the aeration pipes and, if not vented, can accumulate and block the air flow. The combined leachates and condensate may amount to as much as 5 gallons per day per ton of dry sludge. If the bulking material is sufficiently dry to begin with, there will be no leachate drainage from the pile. Since the leachate contains sludge fractions, it can be a source of odor if allowed to accumulate in puddles, so it should be collected and handled in the same manner as runoff water from the site.

The purpose of screening is to recover the bulking material for reuse and/or to provide for a better product.

Bulking materials are not always available and may represent a substantial operating cost. At Beltsville the cost of wood chips represents 19% of the annual operating cost. Wood chip recovery is therefore essential to reduce costs. This cost figure is based on \$3.5 per cubic yard. Screening is expensive requiring labor and capital investment. The use of bulking material such as rice hulls or peanut hulls would eliminate screening.

The physical and chemical characteristics of the final product can affect the agronomic or utilization value of the compost. Particle size can affect application systems. Fine particles of material can be applied with standard fertilizer spreaders, whereas coarse particles may require special equipment. The chemical characteristics will affect the quantity and the way the material can be used. The C/N ratio of the compost should not exceed 30:1 as this will require additional supplemental nitrogen. Wood chips and other high C/N ratio material therefore need to be screened out if the product is to be used as a low-analysis fertilizer (See section on product utilization). If refuse is used as a bulking material, screening is needed to remove undesirable material.

Prior to screening it may be necessary to dry the material. Drying requires both additional land, site development, and labor. At Beltsville for a 10 dry ton per day operation it is estimated that drying costs account for less than 5% of the operational costs. Two screens have been used at Beltsville, a rotary (trommel) and an oscillating or vibratory screen. Both screens can handle material having a moisture content of up to 50%. The moisture content of the material should not be much below 30% since this will lead to dust production. If the material is too wet to screen, drying can be accomplished by spreading the compost and periodically turning or harrowing it.

#### 4. Curing and Storage

After the compost has been cured for about 30 days (screened or unscreened), it may be placed in a storage pile for an indefinite period. Curing further stabilizes the compost. Use of the compost is ordinarily seasonal, with the bulk of it applied either in the spring or fall. Thus, a curing and storage area is needed to accommodate 3 to 6 months production.

During storage, the compost will continue to decompose at a slow rate. Usually this does not present any problem because by this time the compost is well stabilized. Decomposition in storage can be largely curtailed by drying the compost to a moisture content of about 15%. If it is stored in large piles at a moisture content of, say 45%, temperatures will increase to the thermophilic range, and additional composting will occur. This may actually improve the quality of the compost for some uses.

The compost can be stored without cover and may be piled as high as is convenient with the equipment available. Care should be taken to round the tops of the storage piles so that wet pockets do not develop.



5. Distribution

Distribution of the compost will depend on the location and type of market. If the market is located near the composting site then direct haulage is preferable. Distribution centers may be utilized if the market area is wide. The city of Chicago maintains several distribution areas for their "Nu Earth" sludge. Citizens may pick up the material without charge for their use.

The type of market, i.e. agronomic or horticultural, may dictate the packaging aspect of the product (bagged or bulk) and distribution system. Products used for horticultural purposes (nurseries, greenhouses, home use) can command a higher value for the product and may need to be bagged. Agronomic use, for example revegetation of strip mines, will deal with large quantities so that bulk handling is preferable.

Equipment may be needed for loading and packaging depending on the market and the market strategy, which might be:

- a. Composting and marketing to be done by the municipality or sewage authority.
- b. Composting and marketing to be done by private enterprise.
- c. Composting to be done by municipality and marketing or distribution by private enterprise. (Los Angeles County has this system in conjunction with the Kellogg Supply Company).

6. Monitoring and Management

Monitoring is essential to ensure proper operating conditions, high temperatures for pathogen reduction, and odor control. Operational monitoring can be kept at a minimum with low cost, unsophisticated equipment.

a. Temperature

Temperatures will reveal more about the process than any other single parameter. Most of the pile should reach 55°C within 2 to 4 days, indicating satisfactory conditions with respect to moisture content, bulking material ratio, mixing, and pH.

Low average temperatures below 60°C can result from excessive aeration or too high a moisture content. The former can be corrected by reducing the blower cycle or placing a baffle in the pipe just in front of the blower. If the moisture content is too high it indicates an improper sludge to bulking material mix ratio. The pile can then be torn down and rebuilt with additional bulking material and future piles built with the correct ratio. Cold spots in the pile may also result from improper pipe spacing or an inadequate insulation cover. Temperature monitoring should

be done daily for the first week. Once temperatures peak at the desired level only periodic spot checks are needed.

Several simple temperature probes are available and include thermistors and bimetallic probes.

b. Oxygen

Oxygen analysis of gas samples drawn from the center of the piles is useful for locating problems and optimizing the aeration system. The oxygen level should be in the range of 5 to 15%. Scattered readings below 5% indicate poor distribution or movement of air, and are probably the result of an excessively high moisture content or incomplete mixing. If a gas sample cannot be obtained, there are no voids for oxygen movement and the sampling location is probably anaerobic. If all readings are low, the aeration rate should be increased. The type of equipment recommended for monitoring oxygen levels during composting is listed on page 20.

c. Odors

Site operators should pay particular attention to odors. Whenever unpleasant odors are noted, the source should be located and corrective action taken. Exposed sludge, ponding around compost piles, and partially composted sludge are potential odor sources. Improperly constructed odor filter piles or leaky pipes between the blower and the filter pile can also contribute odors. Over a period of time the odor-filter pile can also contribute odors. The odor-filter pile can also collect condensate which lowers the capacity to absorb and retain odors. When the moisture content of the odor-filter piles reaches 75-80%, they should be removed and rebuilt with dry (50% moisture content or less) materials.

While sewage sludge can emit a strong unpleasant odor, it gradually disappears as the sludge is stabilized by composting. Each of the unit operations can be a potential source of odors. Some of the odors emitted are intermittent while others are continuous. Odor potential increases considerably during and immediately following periods of excessive precipitation.

To minimize the odor potential throughout the composting process it is essential to manage each operation as follows:

(a) The mixing operation - Prompt mixing of sludge and bulking material and placement of the mixture in the aerated pile reduces the time for odor generation. An enclosed mechanical mixer could eliminate the release of odors from this operation.

(b) Aerated pile surface - This will not be a source of strong odors if the blanket of compost is adequate for insulation. Thin spots or holes

in the blanket will be a potential source of odors. The effectiveness of the blanket for odor control decreases when its moisture content exceeds 60%.

(c) Air leakage between the blower and odor filter file - Since air leakage can occur at this point, all joints should be sealed. Back pressure from the odor-filter pile should be minimized to prevent gaseous losses around the blower shaft. Back pressure can be virtually eliminated by placing a 4- to 6-inch layer of bulking material under the filter pile.

(d) Odor-filter piles - As mentioned earlier, the odor-filter piles are a potential source of odors. They should be cone-shaped, and symmetrical and contain about 1 cubic yard of dry (50% moisture or less) screened compost per 10 wet tons of sludge being composted.

(e) Condensate and leachate - These are potential sources of odors. As these liquids drain from the compost pile, they should be collected into a sump and conveyed in a pipe to the sewer system or stabilization pond.

(f) Removal of compost from the aerated pile to the curing pile - If the sludge has not been adequately stabilized prior to this operation, odors will be released. Excessive odor during this operation can probably be attributed to too high a moisture content in the composting mixture and can be avoided by lowering the moisture content of the mix with additional bulking material.

(g) Curing piles - These can be a source of odors when the material removed from the aerated pile has not been completely stabilized. The use of drier materials in the initial mixing operation will prevent this problem. Blanketing the curing pile with dry cured compost will also help to contain any odors. Where sludges are incompletely composted after 21 days because of excess moisture, low temperatures, improperly constructed piles, or improperly treated sludge, the odor potential will be high. In these cases, the sludge should not be put on a regular curing pile, but mixed with additional bulking material and composted another 21 days, or put into a separate isolated pile, heavily blanketed with screened compost, and allowed to compost for several months.

(h) Storage piles - Odors could arise in storage if the piles were constructed with excessively wet compost.

(i) Aggregates or clumps of sludge - When aggregates of sludge are allowed to remain on the compost pad after mixing and processing, even though small in size, they can soon emit unpleasant odors. Workers should be made aware of this so that all aggregates of sludge are carefully removed from the mixing area as soon as possible.

(j) Ponding of rainwater - When rainwater is allowed to pond on the site, anaerobic decomposition can occur and cause unpleasant odor. Therefore, the site must be graded and compost piles located so that ponding will not occur.

Studies to define the risk of infection by pathogens for people working with sewage wastes are not as extensive as might be desired, but the available data indicate that the risk is probably low. The predominant route of infection is from the waste material through the mouth. Prevention of infection involves such precautions as thorough washing of the hands before eating to prevent ingestion of the pathogens with contaminated food.

The following recommendations and provisions are advisable to ensure the health and safety of personnel at facilities where sewage sludges are being composted:

- (1) Inoculations for typhoid, tetanus and polio should be given to workers.
- (2) Rules pertaining to personal cleanliness should be posted in appropriate areas. For example, the following items should be emphasized.
  - a. Wash hands before eating, drinking, and smoking.
  - b. Wash hands before returning home after work.
  - c. Never store food in close proximity to sludge or compost samples taken for analysis.
  - d. If accidentally contaminated with sewage sludge or effluent, change clothes, take a hot shower, and put on clean clothing.
- (3) Showers and lockers should be provided at the composting facility.
- (4) The municipality should provide protective clothing for all workers.
- (5) Workers should change from protective clothing to street clothes at the end of each day. Protective clothing should not be worn home.
- (6) As necessary, protective clothing should be cleaned and/or sterilized.
- (7) During periods of dry weather, the area should be sprinkled periodically to ensure that workers do not inhale the dust. During such conditions, workers should be encouraged to wear face masks or respirators.

### **III. Site Design**

The compost site should be located as close as possible to the wastewater treatment facilities. The advantages are:

- a. Low hauling and transportation costs.
- b. Effective utilization of space and elimination of duplicating facilities such as administrative, general storage, and parking.
- c. Elimination of sludge transportation through residential areas.

Since night soil is collected in tank trucks, the compost site can be located in non-residential areas. The site should be located so as to provide easy access for transportation and removal of the product. This may be adjacent to a rail line or barging facility on a river if the product needs to be transported to remote agricultural areas.

Facilities design need to take into consideration climate (especially precipitation and wind) and soil conditions. In areas where precipitation is high or distributed over the entire year, some cover may be needed for the various operations. These areas may also require a stable site underlaid by concrete or asphalt. In addition runoff facilities and drainage systems may be needed.

In dry climates cover is not essential. The Beltsville operation has been in existence for several years without cover. Bangor, Maine, Durham, N.H., and Windsor, Ontario, Canada have been composting in the open without any problems. However, because of the uniformly distributed precipitation in these areas (approximately 100 cm per year, 8 to 10 cm per month) a stable base has been recommended for several of the operations. Muddy conditions make it difficult to operate equipment and provide a potential for odors.

A sludge composting facility should comprise the following areas: (a) receiving and mixing, (b) composting pad, (c) drying and screening, (d) compost curing and storage, (e) storage of bulking material, (f) administrative parking and maintenance building, (g) runoff collection and disposal.

As indicated earlier several of these areas may not be needed. The administrative, parking and maintenance area may already be part of an existing facility. A runoff collection system may not be needed if the runoff can be channeled into a sewage system.

The areas which need to have a stable base are the mixing, composting pad and screening. Materials which can be used for the base are crushed rock, asphalt, concrete or fly ash. Concrete is the preferred material. The City of Windsor, Ontario, Canada, composts on a tile-drained gravel and fly-ash bed. Bangor, Maine, composts on a part of an unused asphalted airport runway. At Beltsville the mixing and composting areas have been asphalted and the screened area is underlain with crushed rock.

Mixing in a stationary mixer (drum mixer or pug mill) will substantially reduce the area required for the mixing operation.

If runoff collection system is necessary, a collection pond fed by waterways can be used. The collected runoff is discharged to adjoining woods or pasture.

In arid areas where high winds exist precautions need to be taken to avoid excessive dust. A shelter belt can greatly reduce the wind velocity within the site. Unpaved areas may require watering to reduce dust.

Land area requirements are estimated at 1 acre per 3 to 5 dry tons (total solids) of sludge produced. The lower figure (1 acre/3 dry tons) includes space for runoff collection, administration, parking, and general storage. The actual composting area (mixing, piles, screening, drying and storage) is estimated at 1 acre per 5.0 dry tons of sludge.

Source of Supply and Types of Equipment for Composting

| <u>Type of Equipment</u>                       | <u>Specifications or Model</u>  | <u>Est. Cost Dollars</u>           |
|--|---|------------------------------------|
| <b>I. <u>Compostive Equipment</u></b>          |   |                                    |
| <b>1. Front-End Loader</b>                     | Rubber wheeled, 3.5-cu. yd. bucket or larger. Approximately 150 hp.   | \$60,000                           |
| <b>2. Mixing Equipment</b>                     |   |                                    |
| <b>a. Tractor &amp; Tiller</b>                 | Standard Farm Equipment   | Tractor \$10,000<br>Tiller \$5,000 |
| <b>b. Easy-Over Compost Turner and Tractor</b> | Mounted on Tractor  | \$5,000<br>(not inc. tractor)      |
| <b>c. Pug Mill</b>                             | Stationary mixing: material needs to be fed into mill. Conveyors' hoppers, etc., may cost an additional \$30,000 or more. | \$20,000                           |

| <u>Type of Equipment</u>                      | <u>Specifications or Model</u>   | <u>Est. Cost Dollars</u>                   |
|---|--|--|
| <b>3. Screens</b>                             |  |  |
| a. Trommel                                    | Specifications to depend on capacity needed; 7-9 mm opening.   | \$60-80,000 (including hoppers, conveyers) |
| b. Shaker                                     | Specifications to depend on capacity needed; 7-9 mm opening.   |  |
| <b>4. Blowers-fans</b>                        |  |  |
|   | 1/3 hp; 115 v<br>22-23 cm (9")<br>Axial vane, centrifugal fan; 3450 rpm<br>335 CFM at 10 cm (4") static pressure | \$80                                       |
| <b>5. Timers</b>                              |  |  |
|   | 4 hr, 115 v with 2 min. intervals  | \$20                                       |
| <b>II. <u>Monitoring Equipment</u></b>        |  |  |
| <b>1. Oxygen Meter</b>                        |  |  |
|   | 0-25% gaseous oxygen portable, D.C., rugged for field use.<br>180-200 cm steel probe needed for gas sampling     | \$600                                      |
| <b>2. a. Temperature indicator Thermistor</b> |  |  |
|   | Portable, rugged for field use, D.C. Range - 20 C <sup>o</sup> to 100 C <sup>o</sup> 1.5 + meter probe           | \$600                                      |
| <b>b. Dial</b>                                |  |  |
|   | Binetal  | \$50                                       |
| <b>c. Thermocouple</b>                        |  |  |
|   | Potentiometer and thermocouple wire  |  |

UTILIZATION OF COMPOST

by

Eliot Epstein, Ph. D.

The potential for utilization of compost in Developing Countries will depend on several factors. These factors are discussed under three headings.

- I. Socio-economic factors
- II. Edaphic factors
- III. Marketing factors

I. Socio-Economic Factors

A. Population - Population density will affect the availability of raw materials for composting. Sparsely populated areas will increase the cost of collection and transportation resulting in projected increase costs of the final product. The availability of a centralized collection system may result in reduced costs and facilitate handling and composting.

B. Industrialization - If industrial wastes contribute to the sludge being composted, pollution from heavy metals and organics can result in a low value or undesirable product. The heavy metals of greatest concern are zinc, copper, nickel and cadmium. Zinc, copper and nickel in large amounts can result in soil enrichment and cause phytotoxic effects resulting in decreased crop growth and yield. Heavy metals may also accumulate in plant tissues and enter the food chain through direct ingestion by humans or indirectly through animals.

The element of greatest concern to human health where sewage sludges and sludge composts are applied to land is cadmium (Cd), since it is readily absorbed by most crops and is not generally phytotoxic at the concentrations normally encountered. Therefore, Cd can accumulate in plants and enter the food chain more readily than, for example, lead (Pb) or mercury (Hg), which are not absorbed by crops to any great extent. Most human exposure to Cd comes from food (principally grain products, vegetables, and fruits) and results in an accumulation of the element in the liver and kidneys. Approximately 3 to 5 percent of dietary Cd is absorbed by these organs. Absorbed Cd is excreted very slowly and can accumulate to levels which might be expected to cause kidney damage and failure. Among the sources that contribute to the level of Cd in food are (a) soils and surface waters contaminated by disposal of wastes, (b) soils inherently high in Cd because of geochemical factors, (c) food processing, (d) industrial fallout, and (e) phosphatic fertilizers containing Cd.



The World Health Organization (WHO) has established that the maximum permissible level of dietary Cd should not exceed 70 micrograms per person per day. The U.S. Food and Drug Administration (FDA) calculates that U.S. citizens now ingest from 70 to 90 percent of this amount, and that any further increase in dietary intake of this element should be limited wherever possible. Thus, the level of the Cd in food chain crops may ultimately impose constraints on land utilization of organic wastes as fertilizers and soil conditioners.

Plant species, as well as varieties, differ markedly in their ability to absorb and translocate heavy metals and to accumulate them within edible organs of the plant. Leafy vegetables are usually sensitive to the toxic effects of metals: cereal grains, corn, and soybeans are less sensitive; and grasses are relatively tolerant. Uptake studies with corn, soybeans, and cereal grains have shown that heavy metals accumulate to a lesser extent in the edible grain than in the leaves.

The availability and uptake of heavy metals by plants are influenced by certain chemical and physical properties of soil, especially pH, organic matter, cation exchange capacity (CEC), and texture (i.e., the proportions of sand, silt, and clay). Phytotoxicity and plant availability of sludge-borne metals are increased in acid soils. Maintaining soil pH in the range of 6.0 to 6.5 by liming is recommended to suppress the availability of heavy metals to plants. Application of organic amendments such as manures and crop residues can also decrease the availability of heavy metals through chelation and complex formation. The CEC is an expression of the soil's capacity to retain metal cations and is usually associated with higher clay and organic matter contents. Heavy metals are relatively less available to plants in high CEC soils (e.g., clay loams) compared with low CEC soils (e.g., sandy loams). Recent research at Beltsville suggests that on a total metal basis heavy metals are less available to plants in composted sewage sludges than in uncomposted raw and digested sludges. The reason for this is not known and the matter is the subject of continuing research.

Industrial organic compounds such as pesticides, PCBs or PBBs can result in contaminated compost. This could restrict its use and limit its market availability.

If industrial contamination is suspected, i.e. if plating, pigment and dyeing, pesticide formulations, and insulation industries are present, it would be best to analyze the compost product. Whenever possible, night soil should be kept separate from heavy industrial wastes.

C. Health - Night soil and sewage sludge contain pathogenic bacteria, parasites and viruses. If composting is done properly, it destroys or reduces to insignificant levels all pathogens present in night soil. Thus, if one of the main purposes in composting night soil is to reduce the potential hazard to the local population, then the cost of composting should be partially

borne by the sanitation authorities and not considered in the cost to the farmer. In various countries different agencies or ministries have responsibility for night soil collection. The composting operation could be a shared venture between agricultural authorities, municipalities or other agencies. A study by Papa and Peyron (1970), showed that the use of night soil in agriculture resulted in numerous cases of salmonellosis 1/. Composting of night soil would have destroyed these and other organisms resulting in an economic benefit to the community. This type of socio-economic benefit needs to be considered in the overall cost of composting.

## II. Edaphic Factors

The important edaphic factors are soils, crops and climates.

A. Soils - The application rate of compost will depend on soil texture, slope and depth to water table. Since composted materials are soil conditioners containing small amounts of plant nutrients, they can be used to improve soil physical properties as well as provide fertilizer for plant growth.

The addition of sludge composts to soils is known to improve soil physical properties as evidenced by (a) increased water content, (b) increased water retention, (c) enhanced aggregation, (d) increased soil aeration, (e) increased permeability, (f) increased water infiltration, and (g) decreased surface crusting. Addition of sludge compost to sandy soils will increase the moisture available to the plant and reduce need for irrigation. In heavy textured clay soils, the added organic matter will increase permeability to water and air, and increase water infiltration thereby minimizing surface runoff. In turn, these soils will have a greater water storage capacity to be utilized for plant growth. Addition of sludge compost to clay soils has also been shown to reduce compaction (i.e., lower the bulk density) and increase the rooting depth.

One of the greatest benefits from the use of compost is to reduce the water requirements for plant growth. In arid and irrigated areas this may mean water conservation and reduced irrigation frequency.

Table 1 gives recommended compost application rates for various soil conditions. These application rates are designed to provide necessary material for soil improvement as well as plant nutrients.

B. Crops - Compost can be used to provide the total amount of fertilizer needed for crop growth. For developing countries, this would mean the use of compost on crops which will provide the greatest return. This would be particularly advantageous to those countries which do not

---

1/ Papa, F. and Peyron, R. (1970). A contribution to the study of salmonella in Algeria, The Salmonella of Souf. ARCH Inst. Pasteur Alger (AIPSA) 48:61-71.

produce chemical fertilizers or need foreign currency exchange for the purchase of fertilizers.

The application rates of compost as a fertilizer will depend primarily on the nitrogen and phosphorus analysis of the compost and the crop nitrogen requirement.

Most of the nitrogen in sewage-sludge compost is in the organic form and must be "mineralized" to inorganic ammonium or nitrate before it is available for crops.

Research by USDA at Beltsville indicates that from 15 to 20 percent of the organic nitrogen (N) will become available during the first cropping period following application. Thus sludge compost can be considered as a slow-release N fertilizer.

The fertilizer benefit to the crop from nitrogen contained in the compost will depend on the following factors:

1. The crop requirement for nitrogen. This will depend on the potential yield, crop variety and species, and edaphic conditions.
2. The percent available nitrogen in the compost. This can be estimated as follows:

$$\% \text{ available N} = \% \text{ inorganic N} + 0.2 \times \% \text{ organic N}$$

3. The amount of nitrogen supplied from the soil as a result of previous practices (fertilization, compost application, manure application etc.)

The following equation can then be used to calculate the compost application:

$$\text{Required N application is kg/ha} \times \frac{1}{\text{Kg available}} = \text{Required}$$

compost in ton/ha. Where required N application = (N required by crop - available soil N).

Table 2 provides the recommended compost application if the material is to be used as a fertilizer. As pointed out earlier, the amount needed for agronomic crops will depend on the N requirement of the crop as well as the N level in the soil.

C. Climate - Organic matter such as compost applied to soils does not break down as readily under moist, cool climatic conditions as under hot, humid climates. These factors should be considered in terms of repeated annual applications. Another aspect of climate is the availability

of rainfall or water for crop irrigation. The application of compost of manures can influence the available water to plants. It may be possible to reduce irrigation frequency as a result of organic matter application.

Table 1  
Recommended Compost Application Rates  
For Various Soil Conditions

| <u>Soil</u>                         | <u>Surface or Ground Conditions</u>                               | <u>Plants or Crops</u>                | <u>Rates Tons/hectare/year</u>                             |
|-------------------------------------|---|---------------------------------------|--|
| Sand or Gravel                      | Shallow to groundwater (less than 4 ft.) with no intervening soil | Grass or shrubs                       | 50 - 100   |
| Sand or Gravel                      | Deep to groundwater (over 6 ft.) Heavier material intervening     | Grass, shrubs, cereals, cotton, crops | 50 - 100<br>50 - 100<br>Amount depends on crop requirement |
| Clays, clay loams, silty clay loams | Shallow to groundwater  | Grass                                 | 50 - 100   |
|                                     | Deep to ground water  | Grass, turf                           | 50 - 200   |
| Disturbed soils                     | Deep to ground water  | Parks, highways construction sites    | 100 - 300<br>tilled into upper 100 mm layer                |

**Table 2**  
**Recommended Compost Application Rates**  
**For Different Plants or Crops**

| <b>Plant or Crop</b>                       | <b>Compost Rate in Tons/ha/yr</b>    | <b>Method of Application</b>             |
|--|--------------------------------------|--|
| Sod, Turf, New Lawns                       | 100 - 200                            | Till into surface layer prior to seeding |
| Sod, Turf, Established Lawns               | 50 - 75                              | Apply onto surface as required           |
| Other Cereals, Cotton, and Agronomic Crops | As required by the crop e.g. corn 50 | Till into soil prior to planting         |
| Tree Nurseries                             | 50 - 100                             | Till into soil prior to planting         |
| Pastures                                   | 50 - 100, depending on species       | Till into soil prior to planting         |
| Pastures                                   | 50                                   | Apply onto surface periodically          |

**III. The Effect of Market Conditions on Compost Utilization**

**A. Market Location - Transportation is expensive. Since night soil is produced in urban areas the transportation of composted night soil can be expensive in comparison to concentrated chemical fertilizers. Compost or night soil is lower in nutrients and therefore larger quantities are needed to provide comparable levels of nitrogen or phosphorus found in chemical fertilizers. Inexpensive transportation means such as water barging or rail to agricultural regions can enhance compost utilization. Distribution and transportation costs would need to be assessed.**

**B. Market Value of Produce or Crops - Compost in developing countries will probably be best used on those crops providing the greatest cost return. Its value to the farmer will depend on the increased yield which would be obtained or on a reduction in production costs. It may be necessary to demonstrate the benefit of the compost through existing agricultural experiment stations or pilot studies.**

**C. Product Quality - Compost product quality can affect its market value and demand. If the night soil is contaminated by industrial wastes or salts and the product is restricted to lower cash crops such as pastures, the demand for its utilization may be reduced.**