

AT MICROFICHE
REFERENCE
LIBRARY

A project of Volunteers in Asia

Public Standpost Water Supplies, Technical Paper #14

Published by:

IRC
P.O. Box 5500
2280 HM Rijswijk
THE NETHERLANDS

Available from:

same as above

Reproduced by permission.

Reproduction of this microfiche document in any form is subject to the same restrictions as those of the original document.

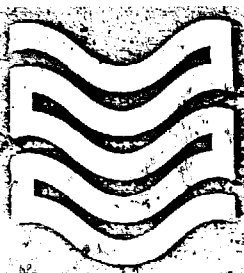

WHO
International Reference Centre
for
Community Water Supply

December 1979

The Hague, The Netherlands

Public Standpost Water Supplies

A Design Manual

14

Technical Paper Series

The International Reference Centre for Community Water Supply (IRC) is based on an agreement between the World Health Organization and the Netherlands' Government. The general objective of the IRC is to underpin information and technology support programmes in developing countries in the field of community water supply and sanitation and to promote international cooperation therein. Acting as a catalyst, the IRC operates through a worldwide network of regional and national institutions, as well as with international agencies, bilateral donors, non-governmental organizations and individuals.

Requests for information on the IRC, or enquiries on specific problems may be directed to the International Reference Centre for Community Water Supply, Information Section, P.O. Box 140, 2260 AC Leidschendam, the Netherlands.

WHO INTERNATIONAL REFERENCE CENTRE
FOR
COMMUNITY WATER SUPPLY

PUBLIC STANDPOST
WATER SUPPLIES

A DESIGN MANUAL

TECHNICAL PAPER 14
DECEMBER 1979

Nieuwe Havenstraat 6, 2272 AD Voorburg (The Hague)
The Netherlands

Postal Address:
P.C. Box 140, 2260 AC Leidschendam, The Netherlands

This report is issued on the responsibility of the WHO
International Reference Centre for Community Water Supply.
It does not necessarily represent the decisions or the
stated policy of the World Health Organization.

TABLE OF CONTENTS

	<u>Page</u>
PREFACE.....	5
ACKNOWLEDGEMENT.....	7
1. INTRODUCTION.....	9
2. THE DESIGN OF A STANDPOST.....	11
3. THE REQUIRED DISCHARGE CAPACITY PER STANDPOST.....	15
4. DESIGN CALCULATIONS	
4.1. Components and Parameters.....	23
4.2. How to Use the Graphs.....	27
5. DESIGN DRAWINGS.....	35
 ANNEXES	
1. Symbols and Abbreviations.....	67
2. Units and Conversion.....	69
3. Growth Factor.....	71
4. Service Radius.....	73
5. Pressure Head Losses.....	75
6. Hydraulic Equations.....	77
7. Stopcock and Watermeter.....	79
8. Materials.....	81
9. Standpost Drainage.....	83
10. Flow Control Mechanisms.....	84
11. List of References.....	91

PREFACE

Public standposts will continue to play an important role in improving and accelerating the provision of water supply and sanitation in rural and urban fringe areas, for a long time to come. In the framework of the International Drinking Water Supply and Sanitation Decade (1981-1990), large investments will be made in this sector in that period. This underscores the need for the development of appropriate methods for the planning, design and construction of public standpost water supply systems.

Throughout the world engineers have designed and installed public standposts, incorporating their own ideas. Often they have had to work from scratch and a great deal of valuable professional time has been spent in working out details. The step-by-step method that forms the basis of this Paper enables an engineer or technician to make the necessary calculations in an efficient way. The drawings and bills of quantities, which form the largest section of the Paper, can easily be adapted to suit local conditions. Therefore by using this Paper any technological skills available can be used in the most effective way in selection and modification to devise the most appropriate project. The Paper may also be utilized effectively as a guideline manual for instruction and training purposes.

JOHN PICKFORD

ACKNOWLEDGEMENT

This Manual and the companion paper "Public Standpost Water Supplies" (IRC/Technical Paper No. 13) result from a study commissioned by The World Bank. The continuous support of the Bank to that study is gratefully acknowledged.

Further acknowledgement is due to the International Water Supply Consultants (IWACO, Rotterdam) for the preparation of this Manual. Also the contributions of Dr. J. Pickford, Group Leader Water and Waste Engineering for Developing Countries (WEDC), University of Technology, Loughborough, United Kingdom, and Mr. D.J. Elliot, Lecturer, University of Newcastle Upon Tyne, United Kingdom, in reviewing this publication are much appreciated. A special word of thanks is addressed to Marylynn Bianco for her organizational assistance, and to Dick Mos for his technical assistance in the finalization of this Paper.

It is intended to further develop and improve this Manual. Therefore, we fully depend on the willingness of its users to inform us about their experiences with this Manual and to communicate their suggestions for improvement. Any such suggestions on this would be highly appreciated.

Eric L.P. Hessing
Programme Officer



1. INTRODUCTION

A public standpost is a suitably supported water pipe, connected with a water distribution system and terminating in a tap or faucet, which is located at a public site, and from which water may be drawn for domestic and other uses. In other publications these installations are also referred to as: public standpipes, public hydrants, public fountains, public taps, public spigots or communal water points.

Public standposts are often installed as an intermediate step in the development of a fully house-connected water supply system. However, for many people, public standposts could well be the only feasible method of water supply for a long time to come. This is especially true in rural areas where a scattered housing pattern makes individual connections very expensive and in urban areas where improvements in housing are needed before house connections can become a feasible proposition; and in general, where funds for investment in water supply are severely limited.

In planning a public standpost water supply system, many organizational, economic, socio-cultural and technological factors have to be taken into account. These factors and their inter-relationships are discussed in the IRC Technical Paper 13, entitled "Public Standpost Water Supplies" which is regarded as a companion document to this Manual.

The present Manual deals with the technical and engineering aspects of the design and construction of public standposts. It offers a step-by-step design method, including the presentation of design criteria, an example design calculation, construction drawings and technical descriptions.

The design and construction of distribution networks are *not* discussed in this Manual. Information on this subject may be obtained from numerous other sources (see Annex 11).

In designing public standposts a number of alternatives have often to be compared, which requires iterative calculations. The reader is advised to study this Manual a number of times as a whole, before using it as a guideline in the actual design of a public standpost water supply.

The symbols and units used in this publication, are listed in Annexes 1 and 2.

2. DESIGN OF A STANDPOST

The layout of the scheme and the siting of the standposts is one of the most important aspects in the design of a public standpost water supply system. In general, standposts should be located as near to as many houses as possible, easily accessible to all users, but protected from vehicular traffic. The walking distance to the farthest dwelling should preferably not exceed 200 metres (m).

A standpost consists of a platform with a drainage facility, a supporting structure for the pipe and taps, a stand for buckets, the service pipe with valve and meter (optional), and the taps.

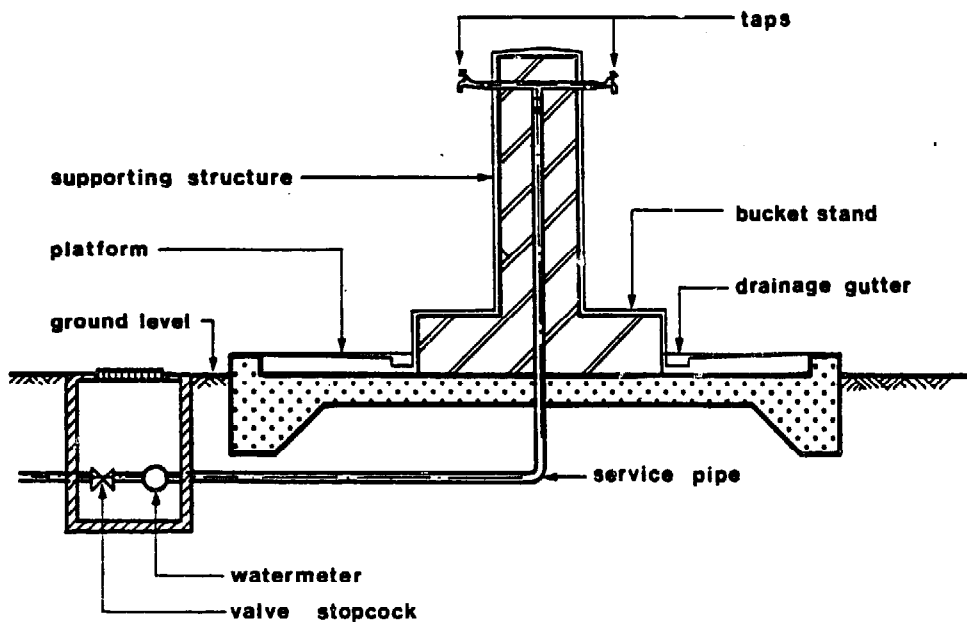

FIGURE 1

CROSS SECTION OF A PUBLIC STANDPOST

The *platform* should extend for at least 1.0 m around the tap(s) and be constructed of hard an impermeable material, preferably concrete or masonry. It should be raised at least 0.10 m above the ground to ensure good drainage and slope away from the taps towards a drainage channel. Alternatively the platform may slope inwards; the waste water is then collected in a gutter underneath the taps and is discharged into a drain.

The slope of both platform and drainage channels should be in the range of 1:50 (2%) and 1:20 (5%). The minimum dimension of the gutter is 0.20 m wide and 0.05 m deep at the beginning of the drain.

If possible, the waste water should be put to some use, for instance: irrigation, cattle watering or fish farming. It may also be led through an open channel to a watercourse, an existing storm-water drain, a soak-away pit or trench.

A soak-away pit consists of a hole of approximately 0.5 m² and 0.80 m deep filled with rubble or gravel through which waste water can filter into the soil.

The required length of soak-away trenches depends on the permeability of the soil; in clay soils relatively long trenches are necessary; in sandy soils short ones will suffice.

The *supporting structure* and the attachment of the taps should be solidly constructed. The best way to protect the pipe is to encase it in a brick or concrete column of at least 0.30 m square. To protect the taps, the supporting structure should extend 0.10 m above them.

Underneath the taps a *raised stand* can be constructed to support buckets and containers whilst being filled. The height of the stand, and of the taps themselves, is determined by the size of the containers used, the manner of carrying them, and the question of whether children as well as adults will fetch water.

For example, if people carry containers on their heads, the stand should be 0.9 to 1.0 m high, with the height of the tap above it dependent on the containers size. Children would need a stand 0.5 m high in this case.

The distance between the tap and the top of the container should be less than 0.5 m in order to reduce the spillage of water.

The *service pipe* or supply pipe may be of galvanized steel or PVC, but PVC pipes should only be used where they are covered and cannot be damaged either by misuse or accident. The necessary pipe diameter is dependent on the required discharge capacity, on the type and number of taps at the standpost and on the water pressure. Normally, the diameter of the service pipe is in the range of 12 mm ($\frac{1}{2}$ -inch) to 36 mm ($1\frac{1}{2}$ -inch).

The *main valve* or stopcock should be installed in a space which can be locked. *Water meters* may provide important information for studies on consumption and wastage, for calculations of future consumption and on decisions regarding the need for additional public standposts; and may serve as means for establishing the payment due for water used. Meters should only be used when they serve a definite purpose and when regular maintenance in a workshop by properly qualified and equipped staff is available. Every meter should be housed in a box which can be locked and should be inconspicuously located.

The *flow control mechanism* most frequently used is the ordinary screw tap with washers. Possible alternatives are: a ball or plug valve tap; spring-loaded or gravity operated taps; volumetric or delayed-closing valves. Reference is made to Annex 10.

Other features can be included in the design, depending on the users' needs and on provisions made for supervision and revenue collection. The standpost may be surrounded by a wall or fence with a locking gate for protection during unsupervised hours. A curb 0.2 m high can prevent damage by traffic, while a wall 0.8 m high around the standpost area and a cattle grid at the entrance, rules out pollution by animals.

3. THE REQUIRED DISCHARGE CAPACITY PER STANDPOST

An important factor in the design of a public standpost water supply system, is the required maximum discharge capacity (Q_{\max}) per standpost.

This parameter is the basis for the hydraulic calculation and the determination of the dimensions of the service pipe and of the type and number of taps.

This Q_{\max} is determined by the design population (N), the average demand per capita (C_d), the peak factor (P), the number of standposts (S), the waste factor (w) and an efficiency factor (f).

The relationship between the factors is presented by the formula:

$$Q_{\max} = N * \frac{1}{S} * \frac{C_d}{24} * P * \frac{1}{1-w} * \frac{1}{f}$$

Each of the six factors that constitute this formula have to be determined separately before the maximum discharge capacity can be calculated.

3.1. Design Population (N)

This factor depends on the initial magnitude of the population to be served, the growth rate of the population, and the design period.

The *initial number of users* (N_0) in the area to be served by the prospective standposts should be counted or estimated.

An indication of the expected *annual growth rate* (r) of the population can be obtained from historical statistical data on the area concerned. If these are not available, one may substitute figures related to a similar area or to the country as a whole.

The standpost must have sufficient capacity to meet the users' water demands during a period of several years. The *design period* (T) is determined by various technical and economic factors; a period of ten years is usually sufficient, but there may be local reasons that make a shorter or longer period desirable.

The *Design Population* (N) can now be calculated according to:

$$N = N_0 * \{1+r\}^T$$

One may prefer to work with a growth factor: $m = \{1+r\}^T$. In that case use can be made of a table giving the growth factor as a function of a fixed annual growth rate and the design period. In general the growth factor will be in the range of 1.0-1.6 (see Annex 3).

3.2. Demand per Capita (C_d)

The average volume of water drawn from public standposts is typically between 20 and 60 litres per capita per day (lcd). Local habits related to domestic water use will have to be studied in order to establish an accurate figure, particularly in cases where there has been no previous experience with standposts or where other sources are available. Normally, a provision is also made for livestock watering.

Future increases in demand should be provided for. It is advisable to provide excess capacity for a design period of at least 10 years and that allows for an increased consumption per person.

In the design of the distribution network, allowance may also be made for uses other than domestic, such as small industries, etc.

3.3. Peak Factor (P)

During some hours the standpost will be used more intensively than during the rest of the day. The water supply system should be capable of dealing with this peak demand. Therefore, a peak factor representing the ratio between peak and average demand, is introduced in the calculation Q_{\max} . Normally, this peak factor is in the range of 2 to 4, a typical average being 3.

The peak factor can be approximated by $P = 24/t$, in which t is the number of peak hours (normally in the range of 4 to 12 per day). The result of this method tends, however, to be on the high side, as the method presupposes that no water at all is drawn outside the peak hours.

The peak factor should be determined with great care, as it has a considerable influence on the Q_{\max} . It is recommended that the local water collection pattern should always be studied thoroughly.

3.4. The Number of Standposts (S)

The required number of standposts is based on two other design criteria, the maximum walking distance to the standpost and the maximum number of users per tap. These two criteria are directly related to the intended "level of service", which results from the consultations between the users and the planners of the public standpost scheme.

The Maximum Walking Distance

In general it is advisable to limit the walking distance to 200 m and in densely populated areas it is often possible to limit the distance to 100 m. In very sparsely populated areas a walking distance of up to 500 m may sometimes be acceptable.

In densely populated areas, however, the application of this criterion may result in too many users per standpost and per tap. Therefore, a second criterion that relates to the population density in a particular area, is required.

The Maximum Number of Users per Standpost

It is advisable to limit the number of users per standpost to 100-250; in no case should this number exceed 500. The number of users per tap should preferably be in the range of 25-125. This criterion is directly related to the maximum discharge capacity of the taps and to the water collection pattern during peak hours.

Proceeding from more or less evenly spaced standposts in a given area (A) and a set maximum walking distance (R), the number of standposts can be assessed using the formula:

$$S = A/\pi R^2$$

A = total area of the scheme in m²

S = the number of standposts

R = the service radius in m

π = 3.14

It should be noted that the service radius does not exactly equal the maximum walking distance (see Annex 4).

In case the afore-mentioned approximation of the number of standposts (S) leads to a too high average number of users per standpost, one may increase the number of taps per standpost, in order to meet the criterion set for the maximum number of users per tap. However, the number of taps per standpost should be limited to avoid the crowding of too many people near one standpost; it is advisable not to install more than four taps per standpost. If by providing more than one tap the criterion of the maximum number of users per tap can still not be met, the number of standposts in the area under consideration is to be increased.

In practice, the actual local geographical and demographical circumstances will determine the siting and the exact number of standposts and taps, as well as the actual number of users for each standpost. However, in most cases, as a first assessment, the above method gives satisfactory results.

3.5. Waste Factor (w)

Part of the water is inevitably spilt by users when filling their containers or drawing water for immediate use at the standpost. To express this numerically, the waste factor (w) is introduced. This factor can be determined by calculating the ratio of the amount of water actually taken away by the users and the total amount of water discharged through the taps.

Spillage and wastage depend on the way in which containers are filled, the type and condition of the taps, the height of the taps above the bucket-stand, the water pressure, and on whether or not the standpost is supervised.

The waste factor can best be estimated from data obtained in other schemes. It should only include the spillage and wastage related to the collection and use of water at the tap and not the leakage of water in the main and branch pipes of the distribution network, as this leakage water is not discharged through the taps.

The waste factor is in the range of 0.1 to 0.4 which means that 10 - 40% of the total discharge at the tap is spilt or wasted. As the waste factor has a considerable influence on the Q_{\max} careful assessment of the factor is required.

It is important to decide whether water used for purposes, such as washing of utensils and personal cleaning at the tap should be considered as part of the per capita demand or is to be regarded in terms of spillage or wastage.

3.6. The Efficiency Factor (f)

The efficiency factor is introduced to take into account that the suppliers rating of the capacity of a tap is usually based on continuous discharge at 10 mhw with the tap fully open. In practice the pressure will never be exactly 10 mhw and discharge is usually not continuous. The closing and opening of the tap will make the actual discharge smaller than the theoretical maximum.

Depending on the type of tap, the efficiency factor (f) can range from almost 1.0 for a ball valve (rapid closing tap), to 0.9 and 0.8 for an ordinary screw tap, and 0.7 for spring-loaded taps.

3.7. Calculation Example

The calculation of the required maximum discharge capacity of standposts can best be illustrated by an example; assume the following situation:

N_0	=	initial number of users = 12 000
r	=	population growth rate = 2% per year
T	=	design period = 10 years
A	=	area of scheme = 100 ha = 1.10^6 m^2
S	=	number of standposts
C_d	=	average demand per capita = 40 lcd
t	=	number of peak hours = 4.5 h
w	=	wastage factor = 0.2
f	=	efficiency factor = 0.9

The design population can be calculated as:

$$N = N_0 * \{1+r\}^T = 12000 * 1.02^{10} = 12000 * 1.22 = 14640 \text{ persons.}$$

If the service radius is set as $R=200$ m and the number of users per standpost is limited to 250, the *number of standposts* can be determined as follows:

- $S > A/\pi R^2 = 10^6/3.14 * \{200\}^2 = 7.96$ and
- $S > N/250 = 14640/250 = 58.56$

Consequently, the maximum number of users per standpost is the decisive factor in this case (b). If the number of standposts is now set at 60, the average number of users per standpost is: $14640/60 = 244$ persons, and the service radius about 73 m.

The required discharge capacity per standpost can be calculated as:

$$Q_{\text{max}} = \frac{N}{S} * \frac{C_d}{24} * P * \frac{1}{1-w} * \frac{1}{f} =$$

$$\frac{14640}{60} * \frac{40}{24} * \frac{24}{4,5} * \frac{1}{\{1-0,2\}} * \frac{1}{0,9} = 3012 \text{ l/h}$$

If the area had been 1000 ha instead of 100 ha, the result of the equation $S \geq A/\pi R^2$, for $R = 200$, would have been 80 standposts and the criterion of the maximum walking distance would have been decisive (a). The average number of users per standpost would then have been: $14640/80 = 183$ and the Q_{\max} equal to 2260 l/h per standpost; assuming that population and standposts are evenly distributed.

However, in practice, and particularly in larger areas, the *population will almost never be evenly distributed*. Therefore, the number of standposts and their location will always have to be determined on the basis of the local geographical circumstances, including the variation in population density in the area concerned. This may lead to a variation in the number of users per standpost and subsequently to a difference in the required discharge capacity of the various standposts.

The above serves to show that, generally speaking, the maximum number of users per standpost will be the criterion in densely populated areas, whilst in sparsely populated areas the maximum walking distance will be the decisive factor.

Finally, it should be pointed out that Q_{\max} , as calculated in this Chapter, only relates to water that is actually discharged via standposts. The total amount of water that is pumped into the distribution network is often reported to be 10-50% higher than the total discharge via standposts and house connections. This is due to *leakage in the pipe system*. This factor is *NOT* included in the calculations in this publication, as this publication only deals with the discharge from standposts.

All the afore-mentioned values have been assumed. The designer should substitute his own data depending on the characteristics of the system he is working on.

4. DESIGN CALCULATIONS

Following the calculation of the maximum required discharge capacity (Q_{\max}), the diameter of the service pipe and the required number of taps can be determined. Use is made of a number of graphs, which give the headloss for each component of the system. Before this method is explained in detail (see paragraph 4.2.) a short introduction is given on the various components and parameters that play a role in the graphical calculation.

4.1 COMPONENTS AND PARAMETERS

The sequence of presentation of the components is the same as the sequence followed in the graphical calculation.

4.1.1. *Watermeter*

Usually a watermeter has its nominal discharge at a pressure head of 10 mhw. This means that a "3-m³" watermeter at 10 mhw discharges 3 m³/h. Higher flows will result in wear of the meter, and impaired accuracy. The calculated discharge capacity of the standpost should be between 50% and 80% of the maximum capacity of the meter (e.g. where $Q_{\max} = 3012$ l/h, a "5-m³" watermeter is a good choice).

The headloss curve of a meter should preferably be obtained from its supplier or manufacturer. However, if this is not available, one can select a sufficiently accurate curve for a meter with a similar nominal discharge from the graphs presented in this Manual.

Meters should only be used when they serve a definite purpose, for instance, to obtain information for studies on consumption and wastage or for determining what payments are due for water use. Very often, however, there is no need for a watermeter and if no watermeter is installed, this component should be disregarded in the graphical calculation.

4.1.2. *Material and Diameter of the Service Pipe*

The material and diameter have a direct influence on the hydraulic characteristics of the service pipe, and of course, the same is applicable to the main. This relationship forms the basis for the formula for the *hydraulic gradient* (see Annex 6).

This hydraulic gradient indicates the headloss per meter of pipe. For a given flow, headloss will decrease as pipes with greater diameter are chosen. It is financially attractive to use the smallest possible diameter pipe that delivers the desired flow at the available pressure. On the other hand, a little extra capacity in the form of a larger pipe may prove a good investment in case of unexpectedly high demands, or a falling off of pressure in the main.

For the calculation of the diameter of the service pipe, two different graphs are available: one for galvanized steel and one for polyvinylchloride (pages 31 and 32).

In the graph of the *galvanized steel (GS) pipes* the specific curves of $\frac{1}{4}$, $\frac{1}{2}$, 1, $1\frac{1}{2}$ and $1\frac{3}{4}$ -inch have been drawn. The internal diameters used comply with galvanized steel pipes, medium class, as specified in ISO-Recommendation R 65, DIN 2240 and BS 1387.

Normalization of steel pipes is nearly worldwide, which is not the case with PVC-pipes.

In the graph of the *PVC-pipes* a bundle of curves with selected internal diameters are presented. However, the actual internal diameters of pipes having the same nominal sizes vary considerably all over the world. Therefore, the most appropriate curve is to be selected from the graph or alternatively a new curve has to be drawn.

To facilitate the choice, some parts of the curves are heavily lined. These parts should be applied with preference so as to ensure that the flow velocity in the pipe is in the range of 0.5-2.0 m/s.

4.1.3. *Length of Service Pipe*

The service pipe should follow the most direct route possible. The length of service pipe should be measured from the connection point at the main pipe to the tap at the standpost. The length, therefore, is greater than the direct horizontal distance between main and standpost (see Annex 5).

In the "length of service pipe" diagram a series of curves has been drawn. The appropriate curve should be selected or a new curve has to be drawn by means of interpolation.

4.1.4. *"Available Head"*

The "available head" is defined as the pressure head that is available to overcome the *hydraulic losses which occur when the water flows* through the pipe, meter and tap. Therefore, the *actual water pressure in the main* has to be adjusted for any *difference in level between the main and the outlet of the taps* (see annexes 3 and 4).

The water pressure in the main or distribution pipe at the point where the service pipe is connected can be measured with a pressure gauge on the pipe, or computed using technical data for the distribution network. Normally, a "design pressure" is chosen of between 5 and 20 mhw; to minimise leakage in the network the pressure is often limited to 10 mhw.

4.1.5. *Type of Tap*

The type of tap to be applied depends upon the required discharge capacity and the availability of the taps.

Generally, the discharge of a tap will be given by the supplier at a pressure head of 10 mhw. A $\frac{1}{2}$ -inch ordinary tap commonly delivers 800 l/h and a $\frac{3}{4}$ -inch tap 1500 l/h at a head of 10 mhw.

In the graph a set of curves is presented for specified discharges at a pressure head of 10 mhw. The most appropriate curve should be selected or a new curve has to be drawn, giving the closest match to the data supplied by the manufacturer of the particular tap.

The preferred range of pressure on the tap (4-10 mhw) is indicated in the graph.

4.1.6. *Number of Taps*

The last section in the graph concerns the determination of the number of taps. Preferably the number of taps on a public standpost should not exceed four, but in the graph the possibility to select up to six taps is offered. A final decision regarding the type and number of taps is often made on the basis of a comparison of existing alternatives. (see calculation examples 4.2.1. and 4.2.2.)

4.2 HOW TO USE THE GRAPHS

The way to find the diameter of the service pipe and the number of taps by using the graphs (on page 33 and 34) can best be explained by means of an example.

The calculation example for the required discharge capacity, as given in item 3.7, is chosen as the starting point: $Q_{\max} = 3012$ l/h.

In addition to this the following assumptions are made:

- length of service pipe = 80 m;
- pressure in the main at the point of connection of the service pipe = 16,5 mhw;
- the taps are located 1,5 m higher than the main.

Before the actual hydraulic calculations can start, we have to determine the *available head*, the actual pressure in the main has to be adjusted for the differences in elevation between the main and the tap(s). Reference is made to Annex 5. In this case the available head can be calculated as $H_a = 16,5 - 1,5 = 15$ mhw.

4.2.1. Example Showing How to Use the Graph for Galvanized Pipes (p.31)

Start from the vertical Q_{\max} - axis horizontally to the watermeter diagram. The watermeter to be used for $Q_{\max} = 3012$ l/h is a "5 m³" meter.

The intersection with the "5 m³" watermeter curve is point 1. The headloss of the watermeter can be read on the horizontal axis (3,7mhw). If no meter is installed, pass horizontally through the watermeter diagram and go directly to the service pipe diagram.

From point 1 travel horizontally to find the diameter of the service pipe, continue to the heavy lined parts of the headloss curves of the service pipes. Find point 2 on the 1½-inch, point 3 on the 1¼-inch and point 4 on the 1-inch curve of the service pipe. There are now three alternatives, and, in principle, all of them have to be considered.

Alternative I (GS; 1-inch Pipe)

Go vertically from point 4, the length of the service pipe diagram and find point 5 at the intersection with the interpolated 80 m curve. The headloss of the service pipe (on the vertical axis) is 20 mhw. The found headloss is more than the "available head" and hence this calculation is stopped.

Alternative II (GS; 1½-inch Pipe)

Go vertically from point 3 to the intersection with the 80 m curve, find point 6, go across to meet the vertical axis of the length of service pipe diagram and read the headloss of the 80 m service pipe which amount to 4,8 mhw.

To graphically make the addition of the headloss of the water-meter and the service pipe, use can be made of the addition diagram. Start at point 7 and travel along the 45 degree incline to find the intersection with the vertical line from the water-meter diagram; this is point 8 and the addition has been made: total headloss 8,5 mhw.

Travel further horizontally to the "available head" diagram; the lines with an incline of 45 degrees represent steps of 5 metres. The intersection with the related line of 15 mhw gives point 9.

From point 9 go vertically down to the type of tap diagram to point 10, read on the horizontal axis the available head on the tap (approximately 7,5 mhw); this is within the recommended pressure range for taps (4-10 mhw). In this case a ½-inch ordinary tap was chosen, with a discharge of 1500 l/h at a pressure head of 10 mhw.

To find the number of taps go horizontally from point 10 to the 'number of taps'-diagram for one ordinate; the other ordinate is the required Q_{\max} (on the horizontal axis). This gives point 12, that lies within the "3 taps area".

The outcome of this alternative is 3 taps of $\frac{1}{2}$ -inch and a $1\frac{1}{4}$ -inch service pipe. But we still have to look at the third alternative as well.

Alternative III (GS $1\frac{1}{2}$ -inch Pipe)

In a similar manner as before travel from point 2 to point 13 in the 'length of the service pipe'-diagram; note that the headloss in the $1\frac{1}{4}$ -inch pipe is less than in the $1\frac{1}{2}$ -inch pipe.

Then to point 14 in the addition diagram, add the headloss in the pipe (2 mhw) to the headloss of the watermeter (3,5 mhw), find point 15, travel horizontally to point 16 in the "available head"-diagram and down to the selected tap curve and point 17, continue horizontally to point 18 to find the result: exactly 2 taps of the chosen type. This would mean that the required maximum discharge capacity of the standpost can never be exceeded because both taps are then operating at their maximum discharge capacity.

If the planner should stipulate that for 244 users at least 4 taps are required, and if several types of taps are available, one can aim at the '4 taps area' and let the type of tap follow from that. The result could then be 4 taps of $\frac{1}{2}$ -inch (nominal 800 l/h) on a $1\frac{1}{4}$ -inch service pipe, or 4 taps of nominal 1000 l/h on a $1\frac{1}{2}$ -inch service pipe.

Before a final decision is made always consider the various alternatives and carry out some iterative calculations regarding the number and type of taps in relation to the diameter of the service pipe.

4.2.2. Example Showing the Use of the Graph for PVC Pipes (P.32)

Start from the vertical Q_{\max} - axis, travel horizontally to the watermeter figure. The intersection with the relevant curve of the "5 m³" watermeter is called point 1. The headloss of the watermeter at a discharge of approximately 3000 l/h is 3,5 mhw.

Travel horizontally to find the service pipe diameters. If the diameters of the available pipes are not among the given curves, new curves will have to be interpolated. This is done as an example and the point 2, 3 and 4 are the subsequent intersections. The three alternatives can be worked out as follows:

Alternative I

Travel from point 4 vertically to meet the interpolated 80 m curve, find point 5 and travel horizontally to meet the vertical axis; the headloss in the service pipe is 9,5 mhw. The addition of the headloss of the watermeter is done by travelling from point 6 along the 45 degree incline to meet the vertical coming from point 1. The found intersection is called point 7 and the total headloss amounts to approximately 13 mhw. If no watermeter is used, disregard this addition and go straight to the available head diagram.

Travel from point 7 horizontally to the "available head"-diagram, meet the relevant head line and find point 8. Note the available head at the tap is only 2 mhw. This is outside the recommended pressure range, hence this calculation is stopped here.

Alternative II

Travel vertically from point 3 to meet the 80 m curve in the 'length of the service pipe'-diagram (point 9). From here go across to meet the vertical axis; the headloss in the service pipe is 3,5 mhw.

From point 10 travel along the 45 degree line to meet the vertical line coming from point 1, and find point 11; the addition of the headloss in the pipe and the watermeter results in 7 mhw. Travel horizontally to the 'available head'-diagram, make the intersection with the relevant line of 15 mhw (point 12), go down the horizontal axis and note the available head on the tap is 8 mhw. This is within the recommended range. Continue to the 'type of tap'-diagram; the intersection with the chosen type of tap is point 13.

To find the number of taps go horizontally from point 13 to the 'number of taps'-diagram for one ordinate. The other ordinate is the $Q_{\max} = 3012 \text{ l/h}$ on the horizontal axis. The intersection is point 14 and lies within 'the 3 taps area'; this means that this alternative results in 3 types of the chosen type, in this case an $\frac{1}{4}$ -inch ordinary tap with a discharge of 1500 l/h at a headloss of 10 mhw, and a PVC service pipe with an internal diameter of 34 mm.

Alternative III

Start at point 2, being the intersection of the 42 mm internal diameter curve and the horizontal line coming from the watermeter diagram, and follow the example in the graph to point 19.

This is just within the border of the recommended pressure range, but the intersection point 20 lies exactly on the boundary of the 'two taps area'. This gives a profit of 1 tap with regard to the second alternative.

LENGTH OF THE SERVICE PIPE

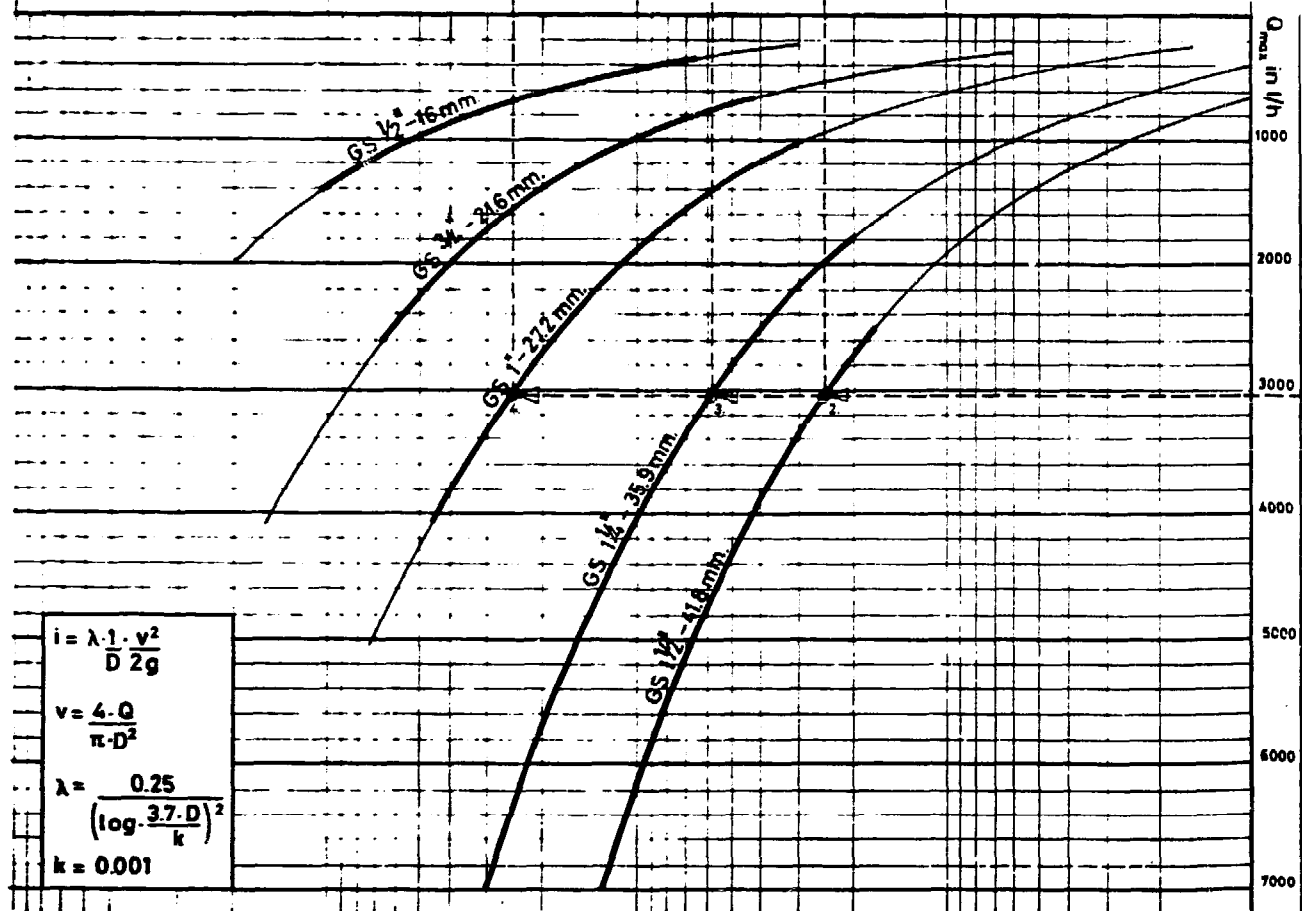
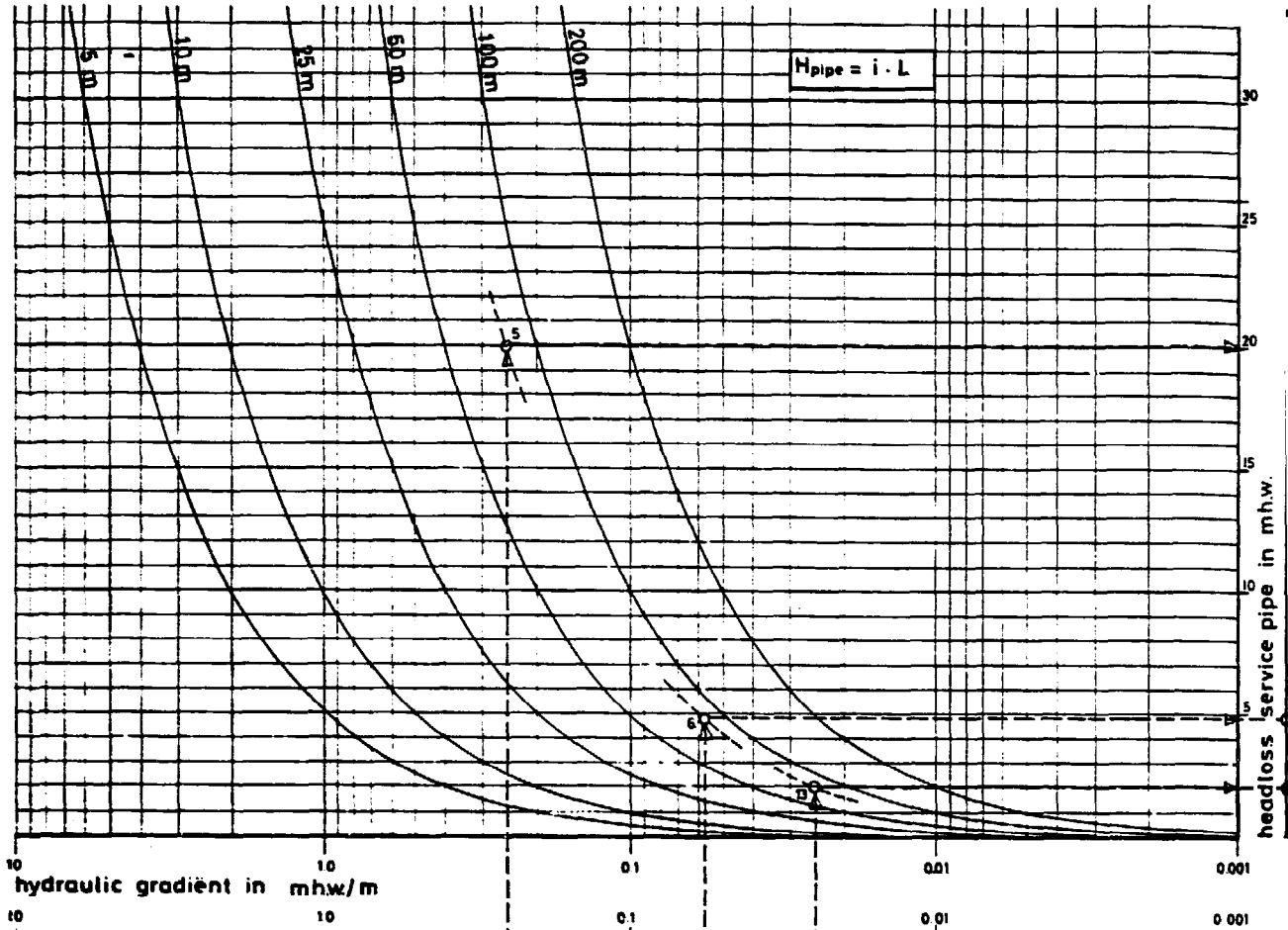

DIAMETER SERVICE PIPE (GALVANISED STEEL).

ADDITION FIGURE

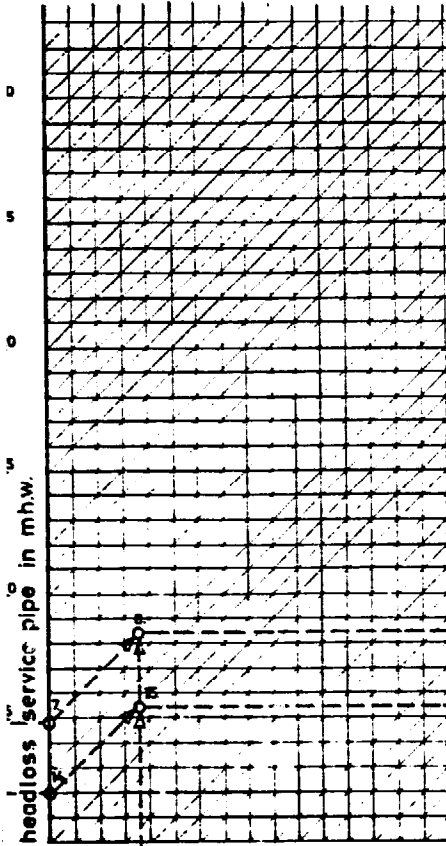

$$H_{total} = H_{pipe} + H_{watermeter}$$

LEGEND FOR FORMULAE

- D = internal diameter pipe in m'
- i = hydraulic gradient in m'/m'
- v = velocity in m/s
- Q = flowrate in m³/s
- g = coefficient of gravity in m/s
- k = pipe roughness in m'
- L = length of service pipe in m'
- H = headloss in m.h.w.
- Q_{spec} = specific flowrate of the equipment referred to in m³/s

IMPORTANT

Ensure that the correct units are used throughout the calculations!

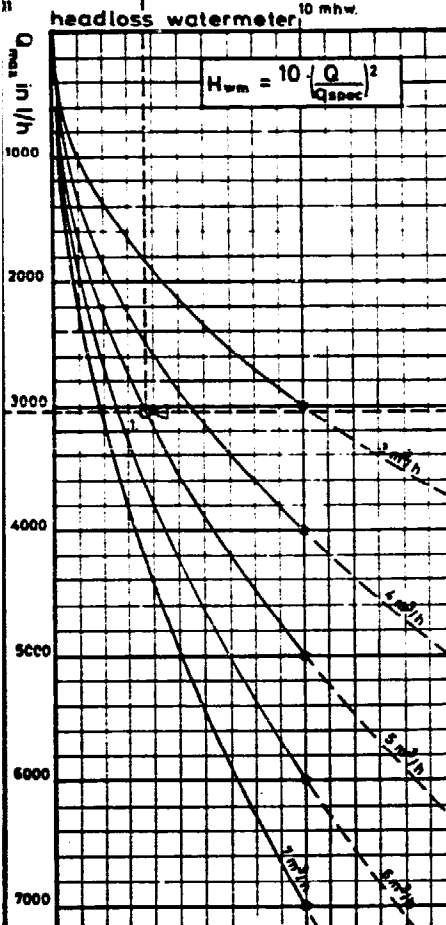

WATERMETER

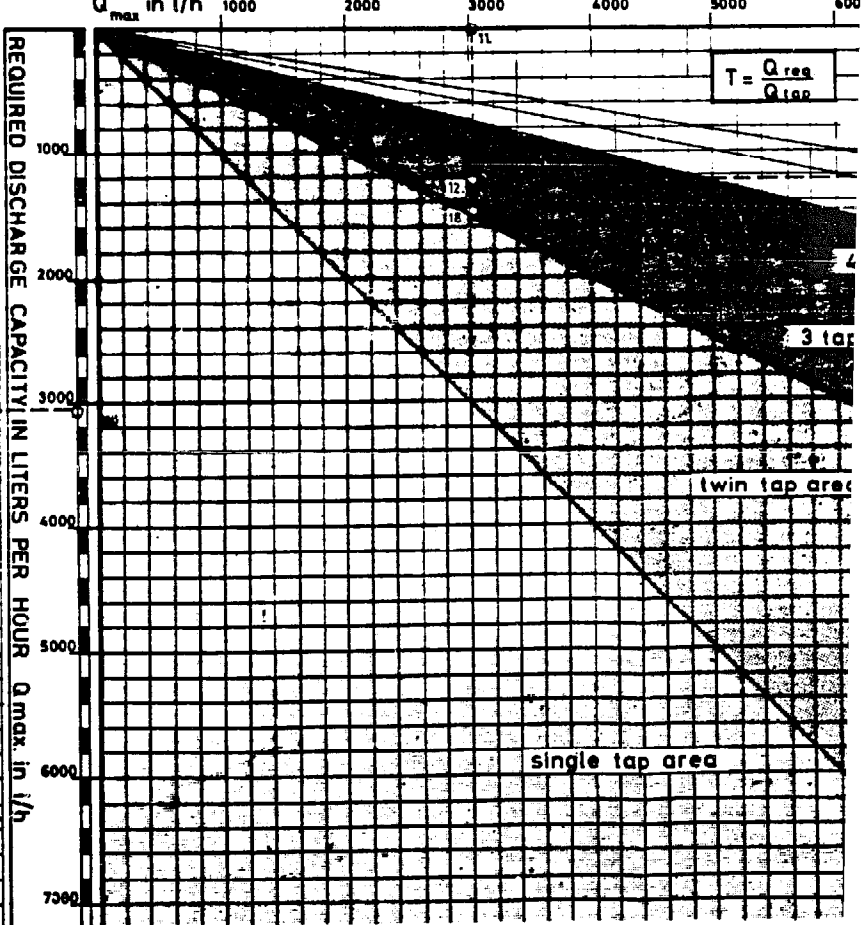

NUMBER OF TAPS

$$H_{total} = H_{pipe} + H_{watermeter}$$

LEGEND FOR FORMULAE

- D = internal diameter pipe in m'
- i = hydraulic gradient in m/m'
- v = velocity in m/s
- Q = flowrate in m³/s
- g = coefficient of gravity in m/s
- k = pipe roughness in m'
- L = length of service pipe in m'
- H = headloss in m h.w
- Q_{spec} = specific flowrate of the equipment referred to in m³/s

IMPORTANT

Ensure that the correct units are used throughout the calculations!

AVAILABLE HEAD

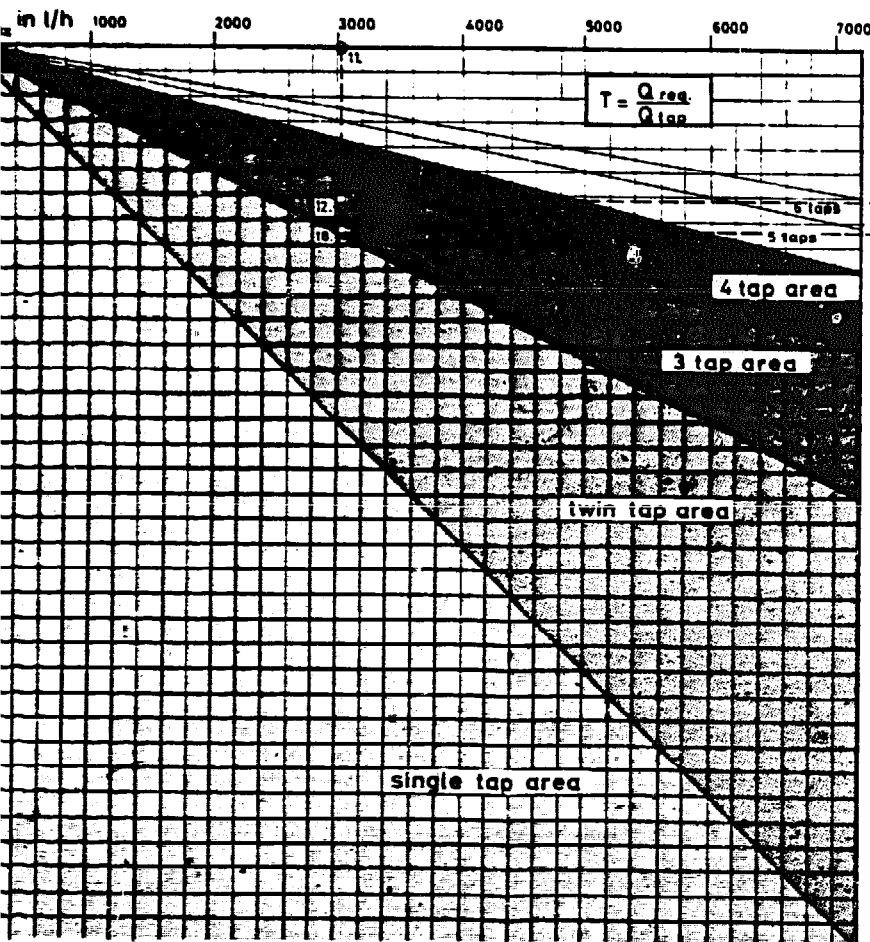
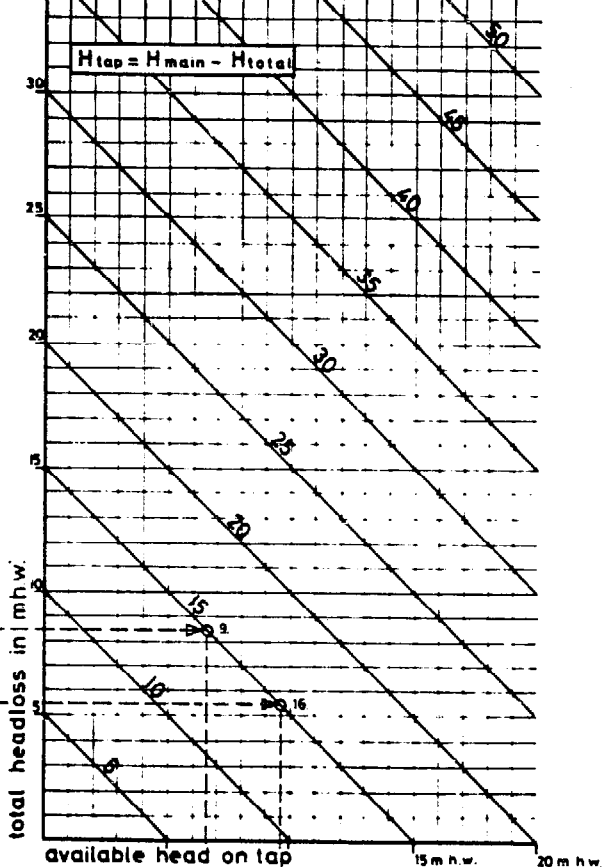

NUMBER OF TAPS

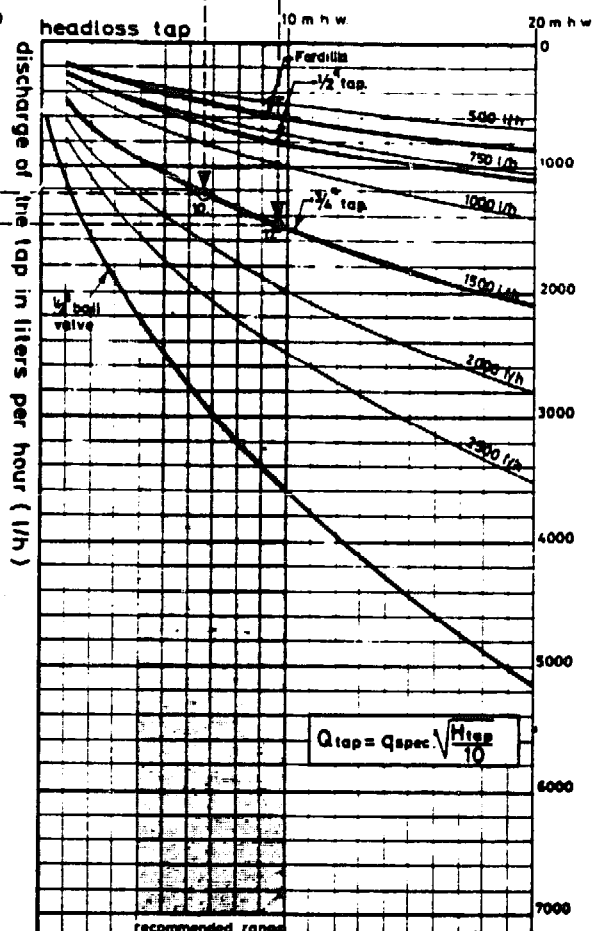

TYPE OF TAP

LENGTH OF THE SERVICE PIPE

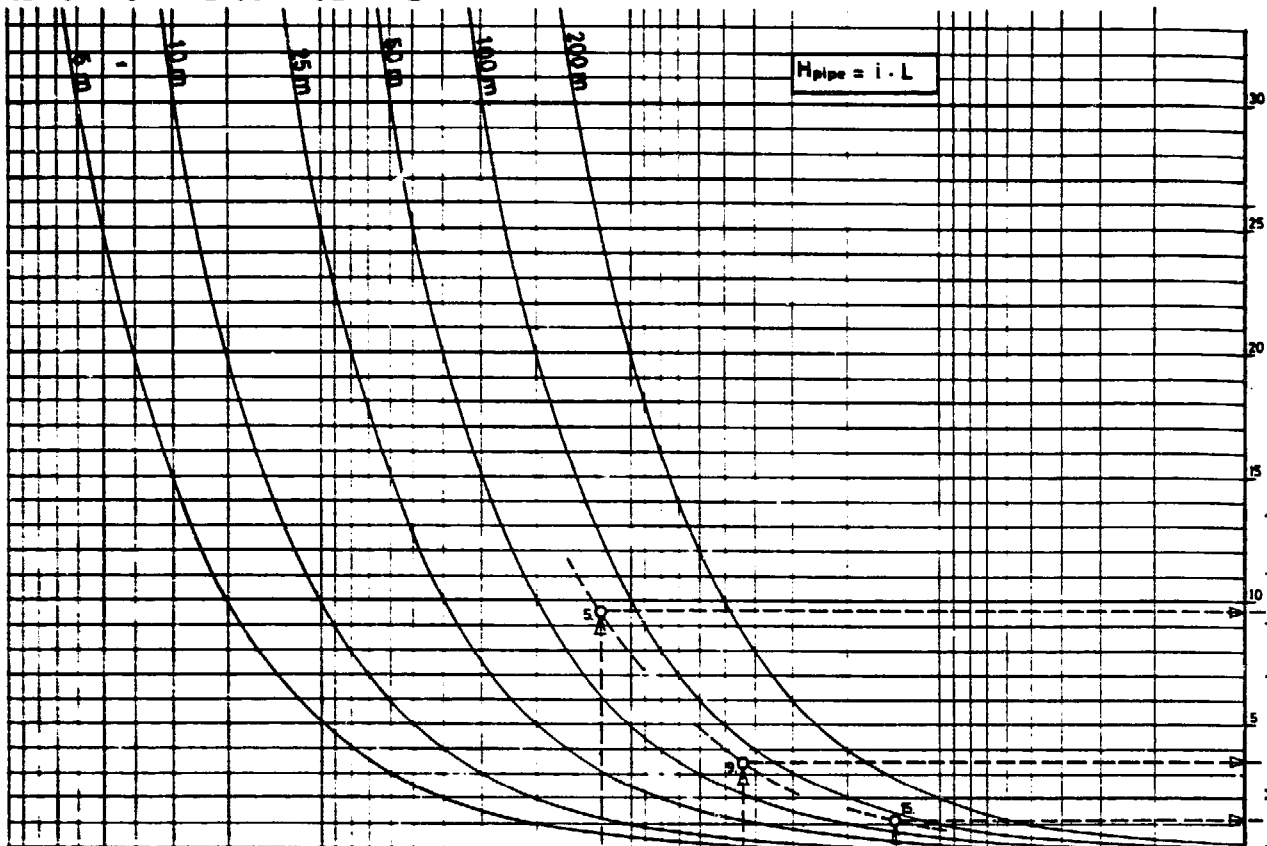

hydraulic gradient in mhw/m

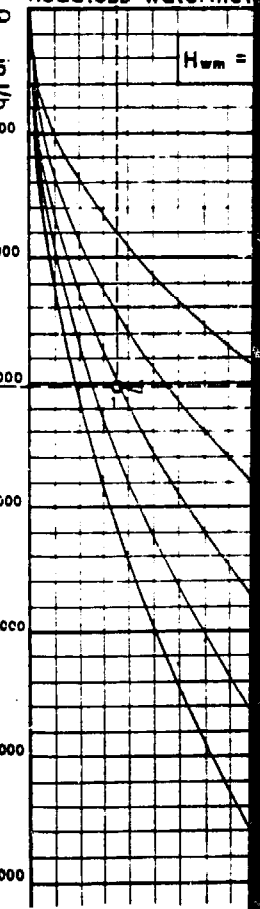
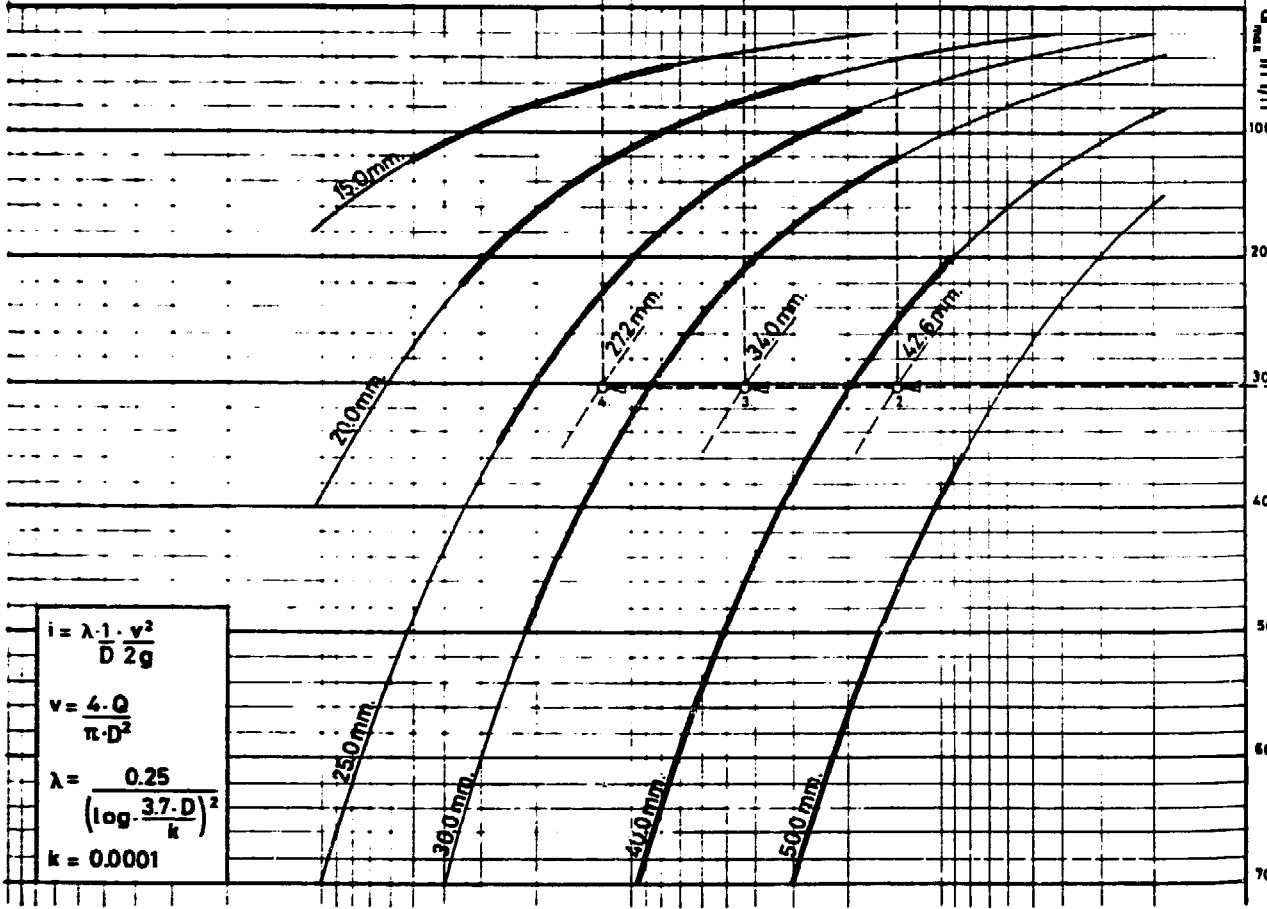
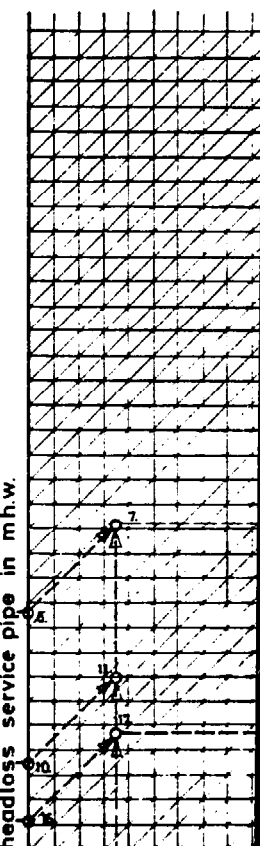

DIAMETER SERVICE PIPE (POLYVINYLCHLORIDE)

WATERMETER

$$i = \frac{\lambda \cdot v^2}{D \cdot 2g}$$

$$v = \frac{4 \cdot Q}{\pi \cdot D^2}$$

$$\lambda = \frac{0.25}{(\log \frac{3.7 \cdot D}{k})^2}$$

$$k = 0.0001$$

$$H_{wm} =$$

ADDITION FIGURE

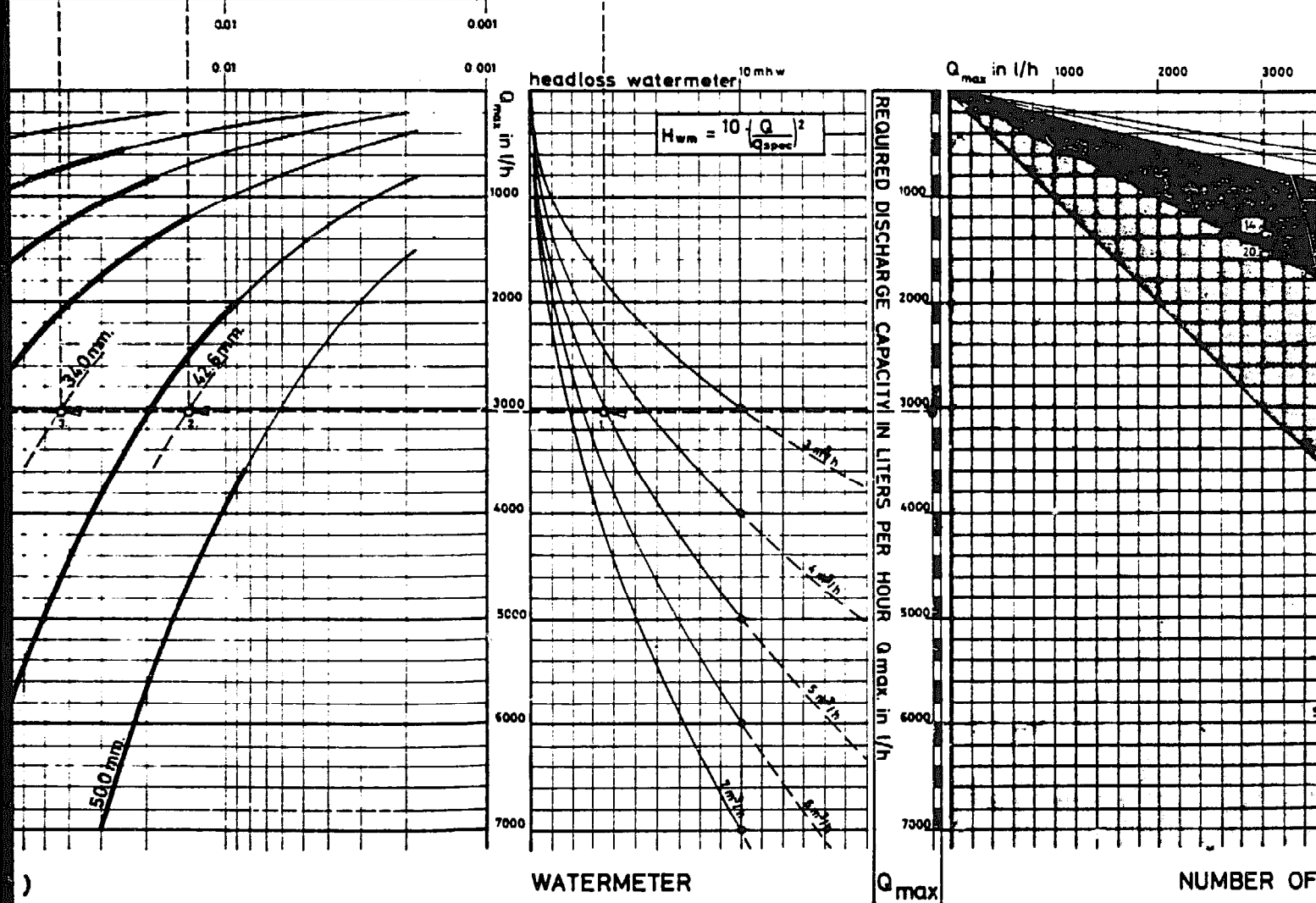
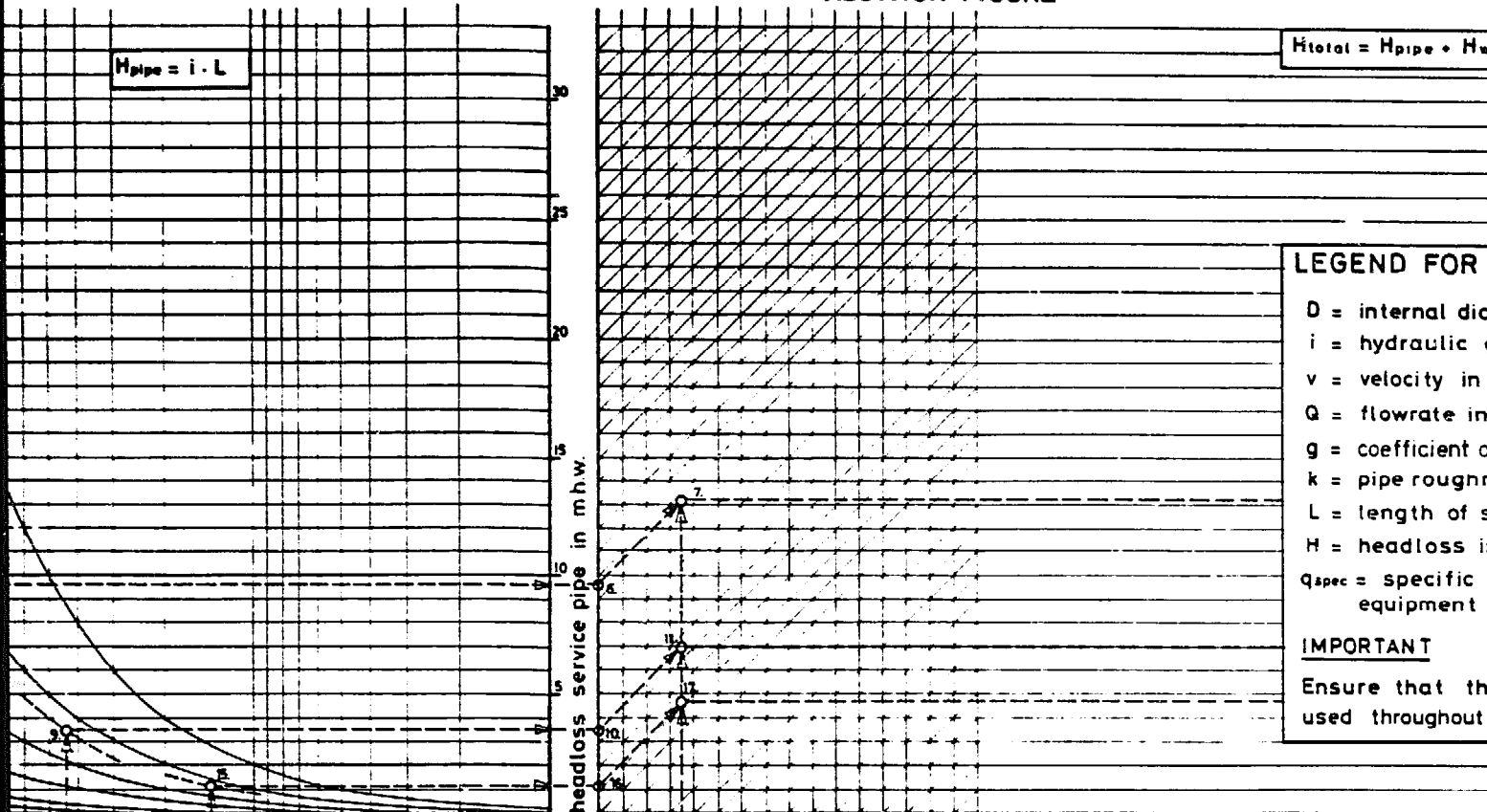

$$H_{total} = H_{pipe} + H_{watermeter}$$

LEGEND FOR FORMULAE

- D = internal diameter pipe in m'
- i = hydraulic gradient in m'/m'
- v = velocity in m/s
- Q = flowrate in m³/s
- g = coefficient of gravity in m/s
- k = pipe roughness in m'
- L = length of service pipe in m'
- H = headloss in m.h.w.
- Q_{spec} = specific flowrate of the equipment referred to in m³/s

IMPORTANT

Ensure that the correct units are used throughout the calculations!

AVAILABLE HEAD

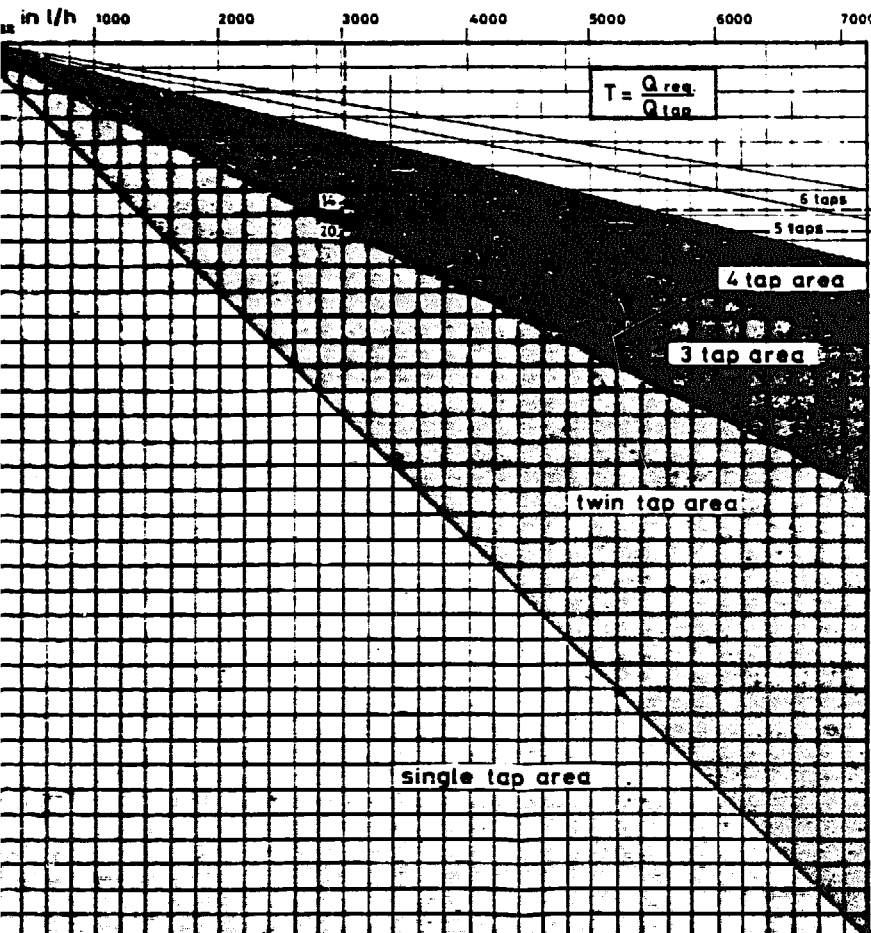
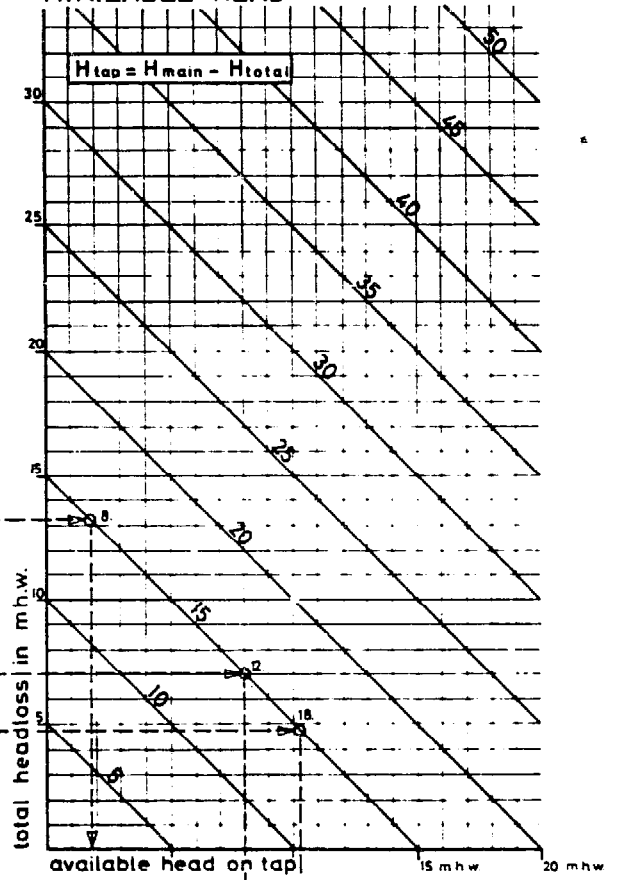

NUMBER OF TAPS

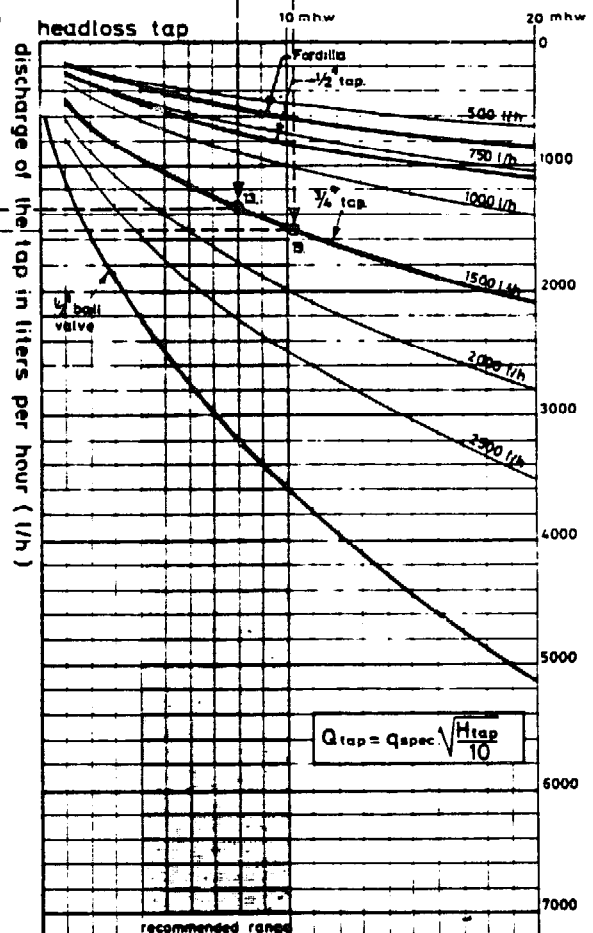

TYPE OF TAP

5. DESIGN DRAWINGS

In addition to the design drawings the following notes are made.

The *service pipe* is the pipe line from the distribution main to the taps. The connection of the service pipe with the main usually consists of a saddle, a T-piece or a ferrule. This is often a weak point in the pipe system and responsible for a great deal of leakage. Thus, it requires much attention during construction.

The choice between *galvanized steel (GS)* and *polyvinylchloride (PVC)* pipes for the service pipe depends on various factors: The advantages of galvanized steel are: the strength, the ease of installation and the availability in almost every country. The disadvantages are: the high weight, the sensitivity to corrosion (internal as well as external) and the relatively high wall roughness in relation to the flowing of water through the pipe.

The advantages of PVC are: the absence of corrosion, the ease of handling due to the low weight and the relatively low wall roughness. The disadvantages are: the limited strength against impact and the lack of standardization in the quality of the material as well as in the pipe dimensions.

It is advisable to always install a *stopcock* in the service pipe, for the purpose of shutting off the waterflow, e.g. for repair or replacing tap washers, etc. The stopcock should be protected and, therefore, installed in a covered pit, preferably within 5 m from the standpost structure. Where a watermeter is used, this should preferably be installed in the same pit.

It is recommended to use galvanized steel pipe for *the part of the service pipe from the stopcock to the taps*; given the higher strength of this material against impact and the ease of installing it and connecting it with the taps. In case the soil has aggressive properties an adequate coating (bitumen or fabric) is required for the part of the pipe that is installed in the ground.

For the purpose of drainage *the slope of the platform* is recommended between 1:50 and 1:20. For a smooth plaster surface a slope of 1:50 is adequate, but for a trowel finished concrete floor, a slope of up to 1:20 is recommended.

To prevent misuse of the taps for hanging buckets, the distance of the taps to the wall should be as small as possible.

In finishing the construction due attention has to be given to the prevention of water-ingress, in particular on the top of the post, on the bucket stand, and at the point where the pipe comes out of the construction.

In general, the design of a standpost should always be adjusted to local habits and circumstances such as the availability of materials and equipment.

TYPICAL DESIGNS DRAWINGS OF PUBLIC STANDPOSTS

- 5.1. Single tap concrete and brickwork standpost
bill of quantities
- 5.2. Twin tap concrete and brickwork standpost
bill of quantities
- 5.3. Three tap concrete and brickwork standpost
bill of quantities
- 5.4. Four tap concrete and brickwork standpost
bill of quantities
- 5.5. Twin tap tubular standpost
bill of quantities
- 5.6. Three tap concrete block masonry standpost
bill of quantities
- 5.7. Four tap concrete standpost
bill of quantities
- 5.8. Four tap concrete standpost
bill of quantities
- 5.9. Four tap rock masonry standpost
bill of quantities
- 5.10. Twin tap reinforced concrete standpost
bill of quantities
- 5.11. Three tap concrete/brickwork cattle protected
standpost bill of quantities
- 5.12. Waterkiosk with 4 taps
bill of quantities

NOTE: The figures in the bills of quantities are to be regarded as indications. The quantities of materials and equipment actually required, are to be calculated specifically for each standpost, according to the actual design.

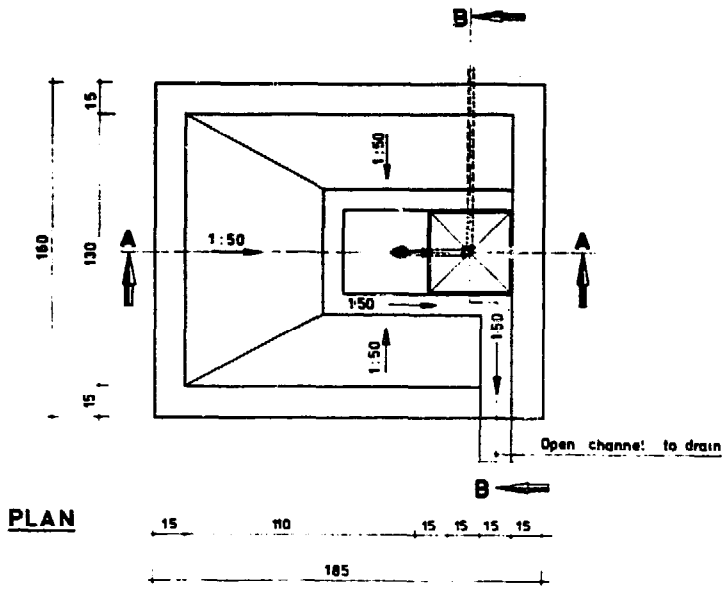

REMARKS

- Dimensions are in centimeters, unless otherwise stated.
- Variable sizes should be adjusted to suit local customs and practices.
- All edges to be rounded off.
- All brickwork to be cement plastered 15-25 cm.
- In the absence of a natural drain around the public standpost drainage should be constructed.

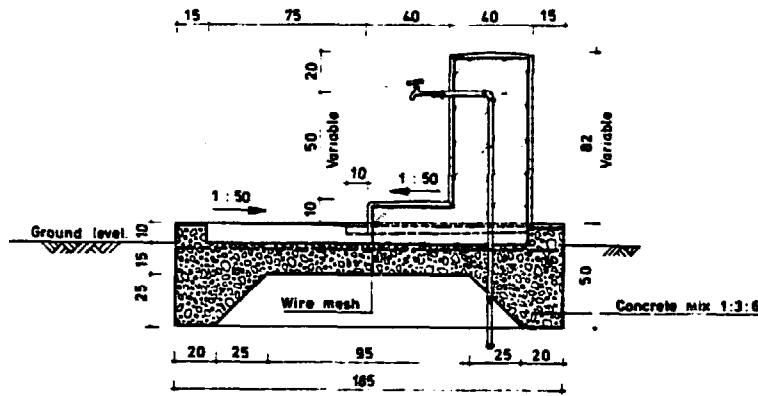

SECTION A-A

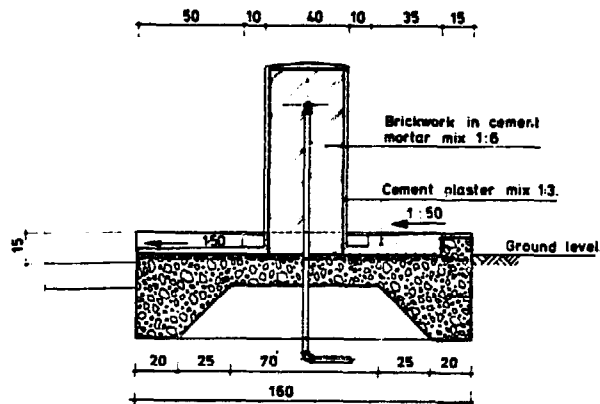

SECTION B-B

SINGLE TAP CONCRETE AND BRICKWORK STANDPOST

BILL OF QUANTITIES OF CIVIL WORKS

ITEM	DESCRIPTION	UNIT	QUAN- TITY	UNITPRICE	AMOUNT
1	EXCAVATION	m ³	1.6		
2	FORMWORK PLATFORM	m ²	4.0		
3	WIREMESH NETTING DIMENSIONS... x ...	m ²	3.0		
4	CONCRETE PLATFORM MIX 1:3:6	m ³	1.0		
5	BRICKWORK IN CEMENT MORTAR MIX 1:6	m ³	0.2		
6	PLASTERING MIX 1:3, INCLUDING GUTTER	m ²	4.3		
7	REFILLING	m ³	0.5		
SINGLE TAP CONCRETE AND BRICKWORK STANDPOST					

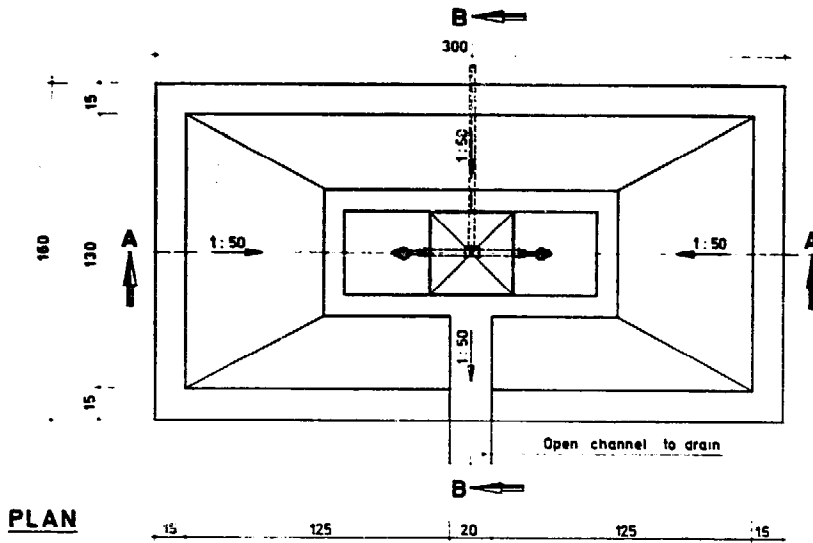

REMARKS

- Dimensions are in centimeters, unless otherwise stated.
- Variable sizes should be adjusted to suit local customs and practices.
- All edges to be rounded off.
- All brickwork cement plastered 15 - 2.5 cm.
- In the absence of a natural drain around the public standpost drainage should be constructed.

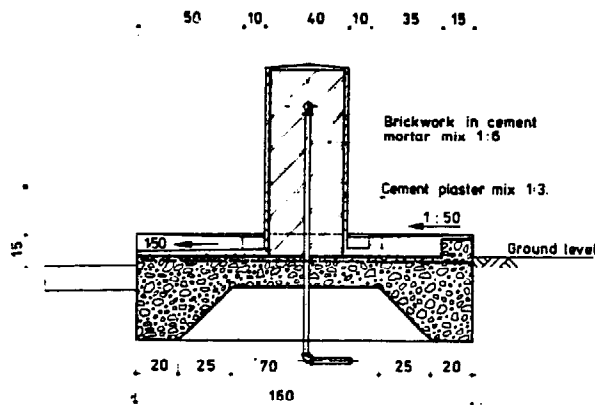
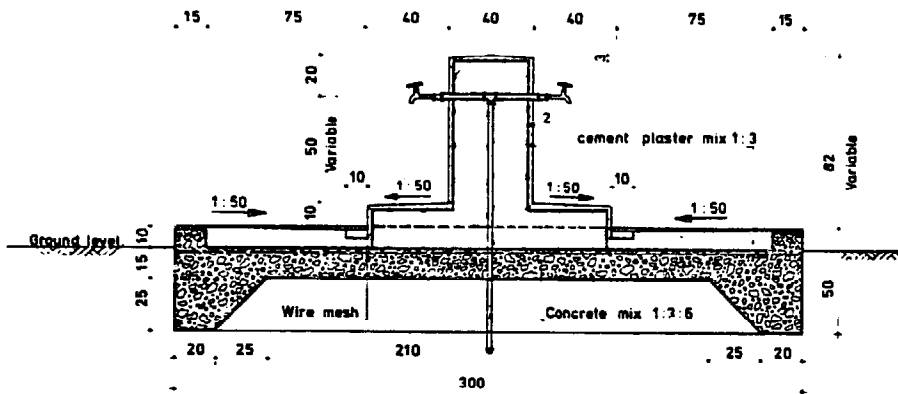

TWIN TAP CONCRETE AND BRICKWORK STANDPOST

BILL OF QUANTITIES OF CIVIL WORKS

ITEM	DESCRIPTION	UNIT	QUAN- TITY	UNITPRICE	AMOUNT
1	EXCAVATION	m ³	2.5		
2	FORMWORK PLATFORM	m ²	5.4		
3	WIREMESH NETTING DIMENSIONS... x ...	m ²	4.8		
4	CONCRETE PLATFORM MIX 1:3:6	m ³	1.5		
5	BRICKWORK IN CEMENT MORTAR MIX 1:6	m ³	0.2		
6	PLASTERING MIX 1:3 INCLUDING GUTTER	m ²	5.0		
7	REFILLING	m ³	0.6		
TWIN TAP CONCRETE AND BRICKWORK STANDPOST					-

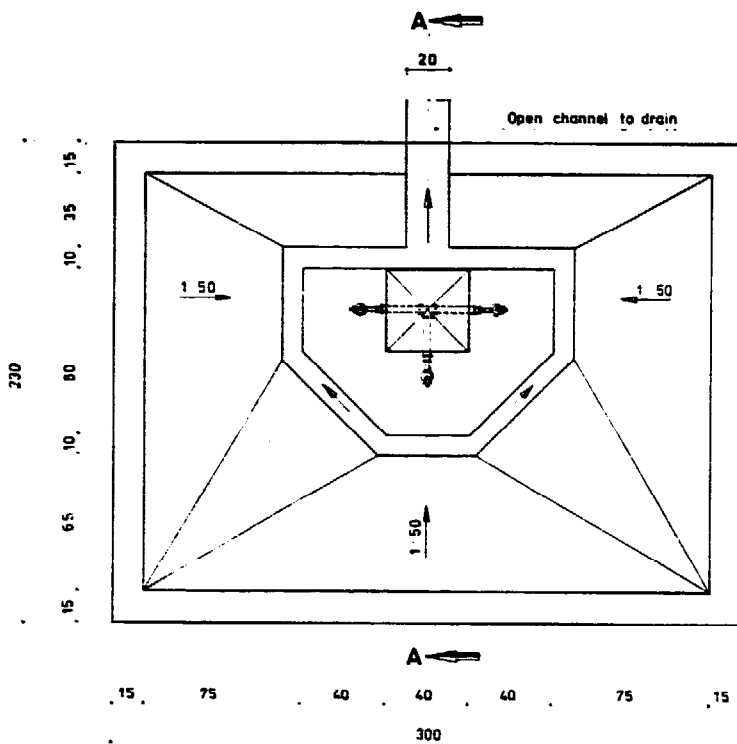

PLAN



REMARKS

- Dimensions are in centimeters, unless otherwise stated.
- Variable sizes should be adjusted to suit local customs and practices.
- All edges to be rounded off.
- All brickwork cement plastered 15 - 25 cm.
- In the absence of a natural drain around the public standpost drainage should be constructed.

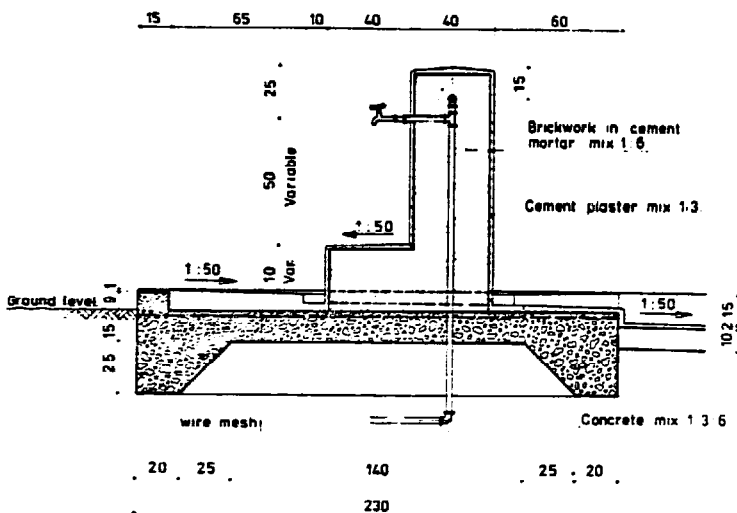

SECTION A-A

THREE TAP CONCRETE AND BRICKWORK STANDPOST

BILL OF QUANTITIES OF CIVIL WORKS					
ITEM	DESCRIPTION	UNIT	QUAN- TITY	UNITPRICE	AMOUNT
1	EXCAVATION	m ³	3.5		
2	FORMWORK PLATFORM	m ²	6.4		
3	WIREMESH NETTING DIMENSIONS... x ...	m ²	6.9		
4	CONCRETE PLATFORM MIX 1:3:6	m ³	2.0		
5	BRICKWORK IN CEMENT MORTAR MIX 1:6	m ³	0.3		
6	PLASTERING MIX 1:3 INCLUDING GUTTER	m ²	8.4		
7	REFILLING	m ³	0.8		
THREE TAP CONCRETE AND BRICKWORK STANDPOST					

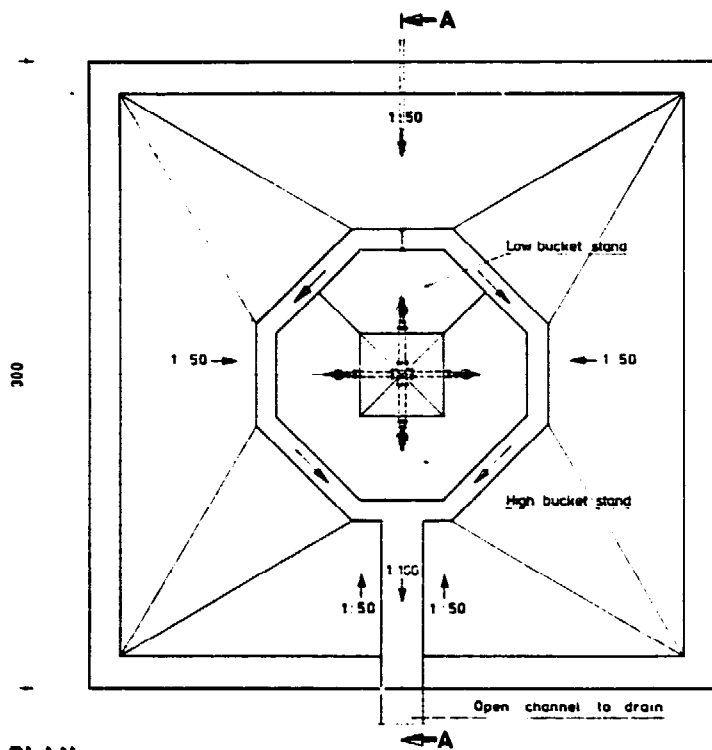

PLAN

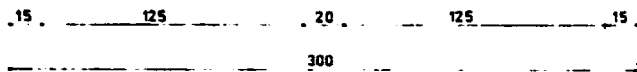

REMARKS

- Dimensions are in centimeters, unless stated.
- Variable sizes should be adjusted to suit local customs and practices.
- All edges to be rounded off
- All brickwork to be cement plastered 1.5-2.5 cm
- In the absence of a natural drain around the public standpost drainage should be constructed.

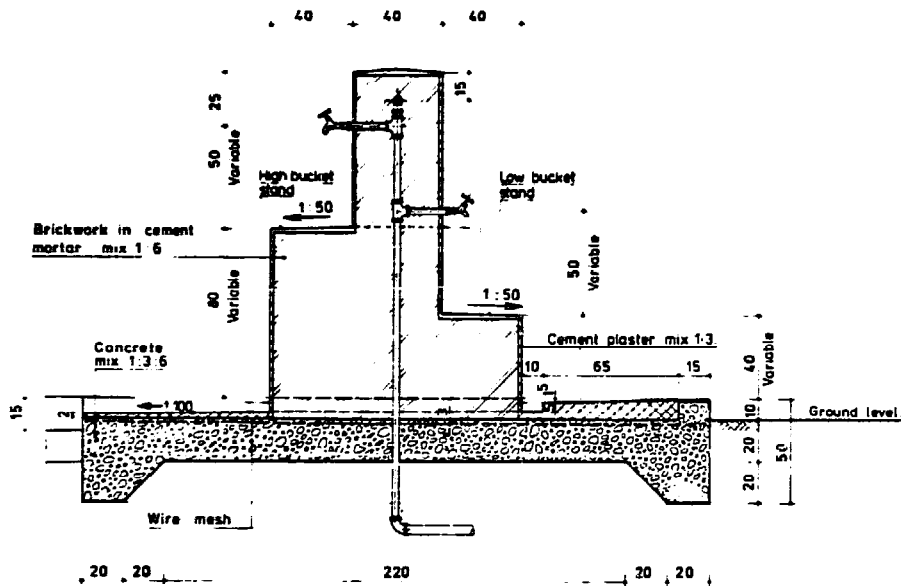

SECTION A-A

FOUR TAP CONCRETE - BRICKWORK STANDPOST

BILL OF QUANTITIES OF CIVIL WORKS

ITEM	DESCRIPTION	UNIT	QUAN- TITY	UNITPRICE	AMOUNT
1	EXCAVATION	m ³	4.4		
2	FORMWORK PLATFORM	m ²	7.1		
3	WIREMESH NETTING DIMENSIONS... x ...	m ²	9.0		
4	CONCRETE PLATFORM MIX 1:3:6	m ³	2.6		
5	BRICKWORK IN CEMENT MORTAR MIX 1:6	m ³	0.8		
6	PLASTERING MIX 1:3 INCLUDING GUTTER	m ²	12.5		
7	REFILLING	m ³	0.8		
FOUR TAP CONCRETE AND BRICKWORK STANDPOST					

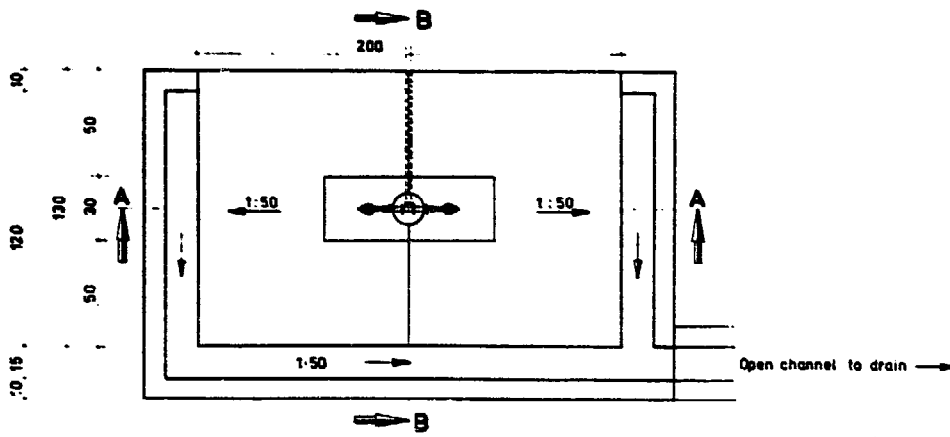

PLAN



REMARKS

- Dimensions are in centimeters, unless otherwise stated
- All edges to be rounded off
- Variable sizes should be adjusted to suit local customs and practices
- Where a variety of materials are used for column construction, sizes and types of fittings should be altered accordingly
- In the absence of a natural drain around the public standpost drainage should be constructed
- Reinforcing bars (φ 12) to be bent after fitting in steel pipe

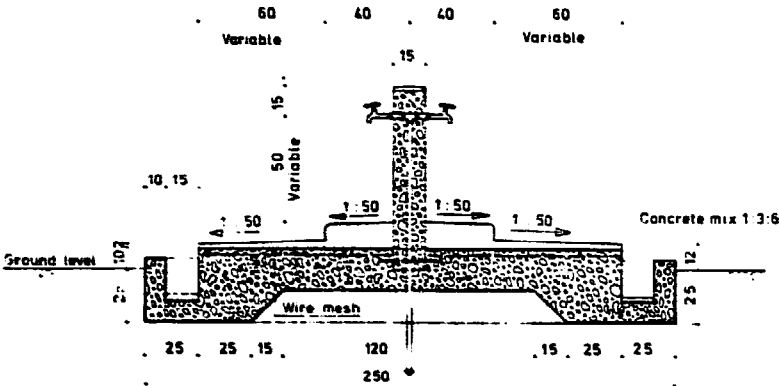

SECTION A-A

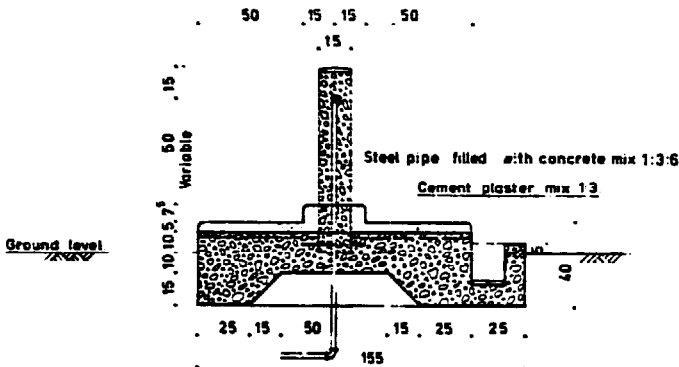

SECTION B-B

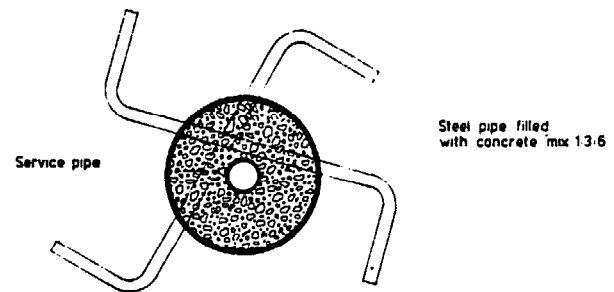
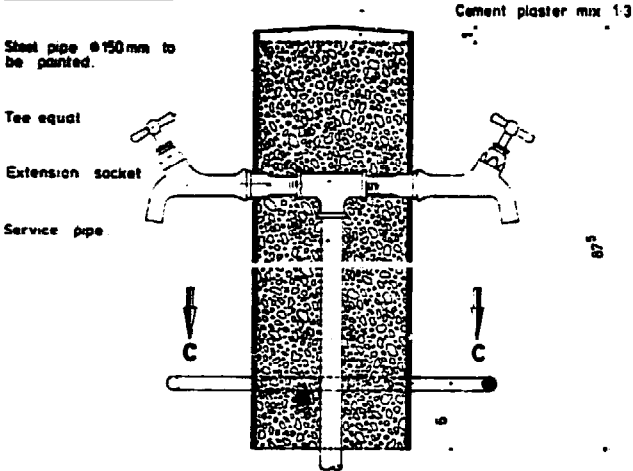

SECTION C-C

φ 12 each 50 cm. long.

COLUMN DETAIL

TWIN TAP TUBULAR STANDPOST

BILL OF QUANTITIES OF CIVIL WORKS

ITEM	DESCRIPTION	UNIT	QUANTITY	UNIT PRICE	AMOUNT
1	EXCAVATION	m ³	1.3		
2	FORMWORK PLATFORM	m ²	4.1		
3	WIREMESH NETTING DIMENSIONS... x ...	m ²	2.6		
4	CONCRETE PLATFORM MIX 1:3:6	m ³	0.9		
5	STEEL PIPE COLUMN POURED WITH CONCRETE MIX 1:3:6	ea	1		
6	PLASTER ON PLATFORM AND BUCKET STAND MIX 1:3	m ²	2.8		
7	REFILLING	m ³	0.3		
TWIN TAP TUBULAR STANDPOST					

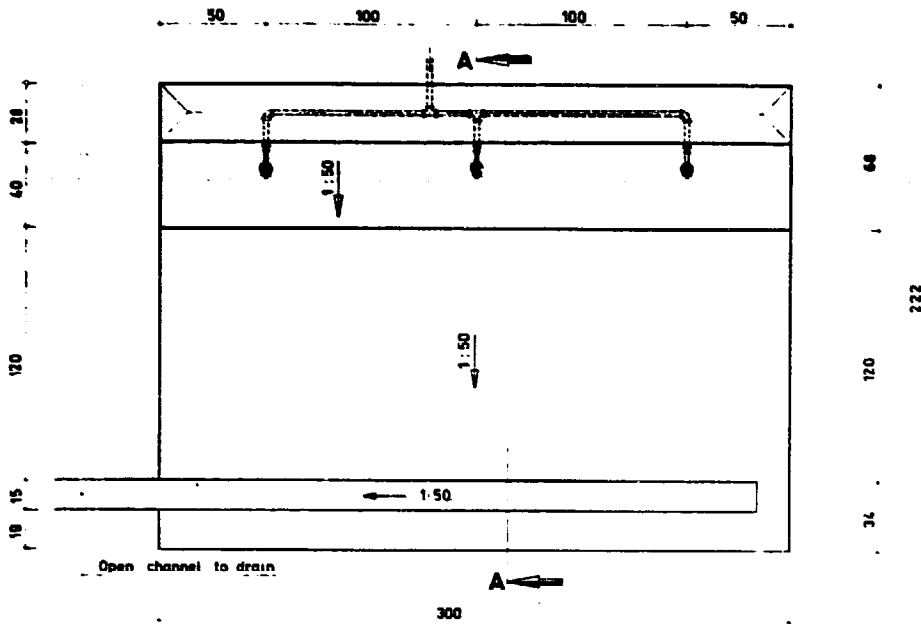

PLAN



REMARKS

- Dimensions are in centimeters, unless otherwise stated.
- All edges to be rounded off.
- Variable sizes should be adjusted to suit local customs and practices.
- Blockwork to be cement plastered 15-25 cm.
- In the absence of a natural drain around the public standpost drainage should be constructed.

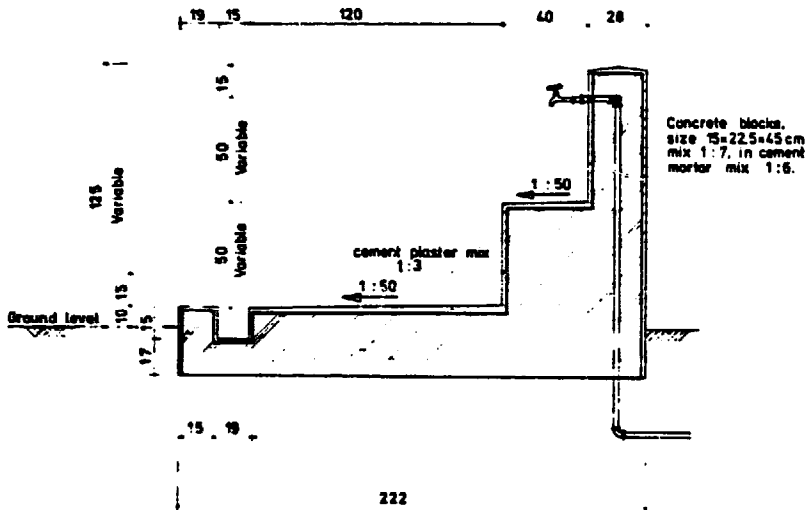

SECTION A-A

THREE TAP CONCRETE BLOCK MASONRY STANDPOST

BILL OF QUANTITIES OF CIVIL WORKS					
ITEM	DESCRIPTION	UNIT	QUAN- TITY	UNITPRICE	AMOUNT
1	EXCAVATION	m ³	1.7		
2	BRICKWORK OF CONCRETE BLOCKS IN CEMENT MORTAR MIX 1:6	m ³	3.5		
3	PLASTER, MIX 1:3, ON COLUMN, PLATFORM AND GUTTER	m ²	14.2		
4	REFILLING	m ³	0.4		
THREE TAP CONCRETE BLOCK MASONRY STANDPOST					

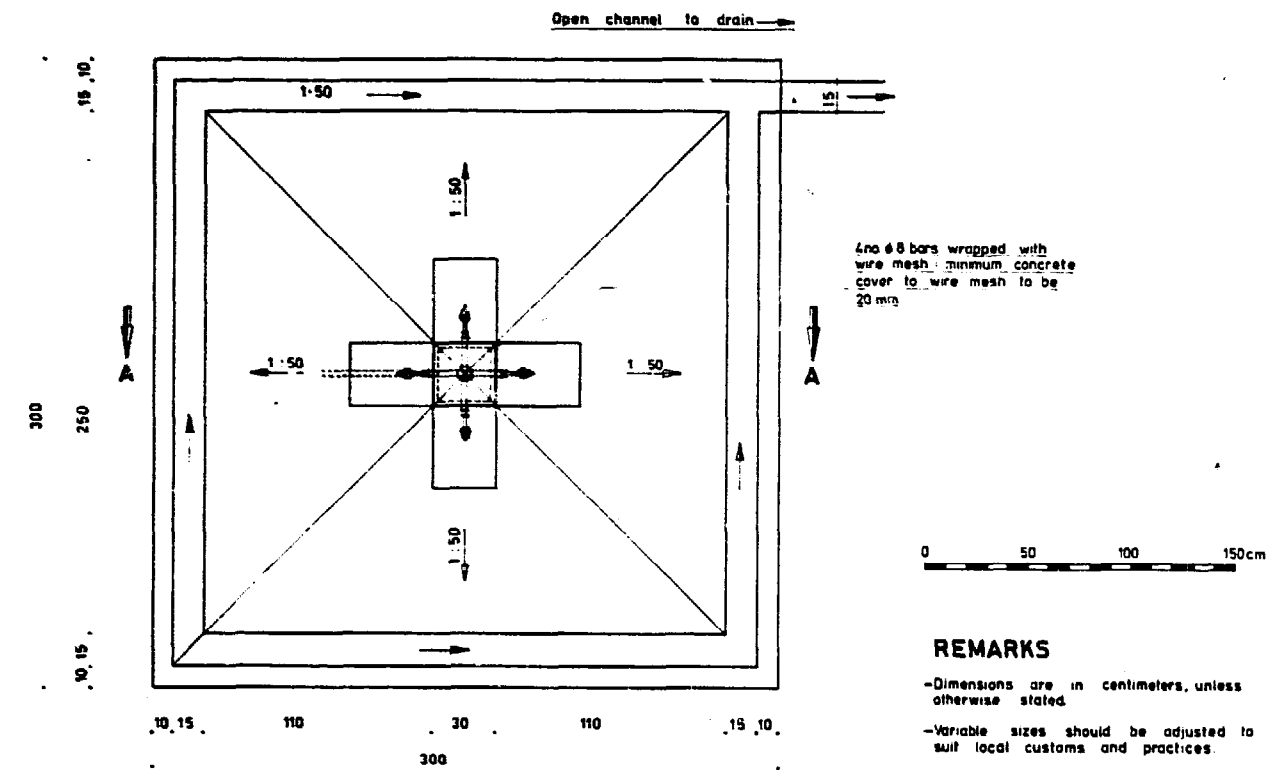

PLAN

REMARKS

- Dimensions are in centimeters, unless otherwise stated.
- Variable sizes should be adjusted to suit local customs and practices.
- All edges to be rounded off or chamfered.
- In the absence of a natural drain around the public standpost drainage should be constructed.
- Exposed surfaces of concrete to be rubbed over with a mixture of cement and water after removal of shuttering.

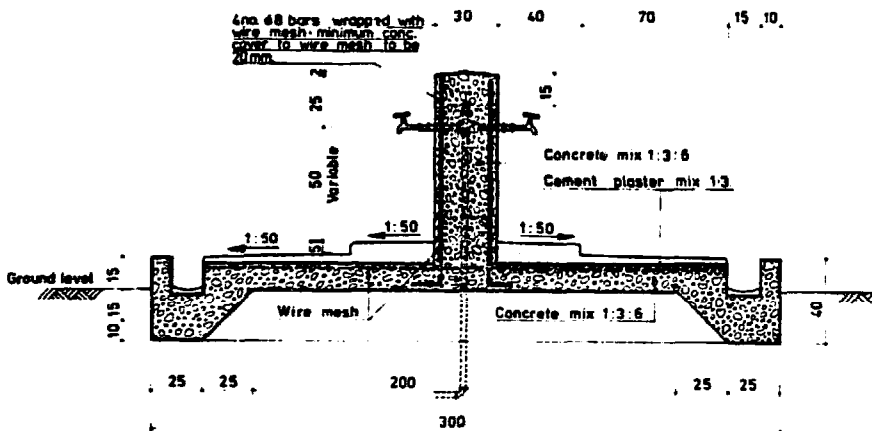

SECTION A-A

FOUR TAP CONCRETE STANDPOST

BILL OF QUANTITIES OF CIVIL WORKS

ITEM	DESCRIPTION	UNIT	QUAN- TITY	UNITPRICE	AMOUNT
1	EXCAVATION	m ³	2.7		
2	FORMWORK PLATFORM	m ²	8.0		
3	WIREMESH NETTING FOR PLATFORM AND COLUMN DIMENSIONS ...x...	m ²	6.2		
4	CONCRETE PLATFORM MIX 1:3:6	m ³	2.1		
5	FORMWORK COLUMN	m ²	1.0		
6	CONCRETE COLUMN MIX 1:2:6	m ³	0.1		
7	PLASTER ON PLATFORM MIX 1:3	m ²	7.9		
8	REFILLING	m ³	0.5		
FOUR TAP CONCRETE STANDPOST					

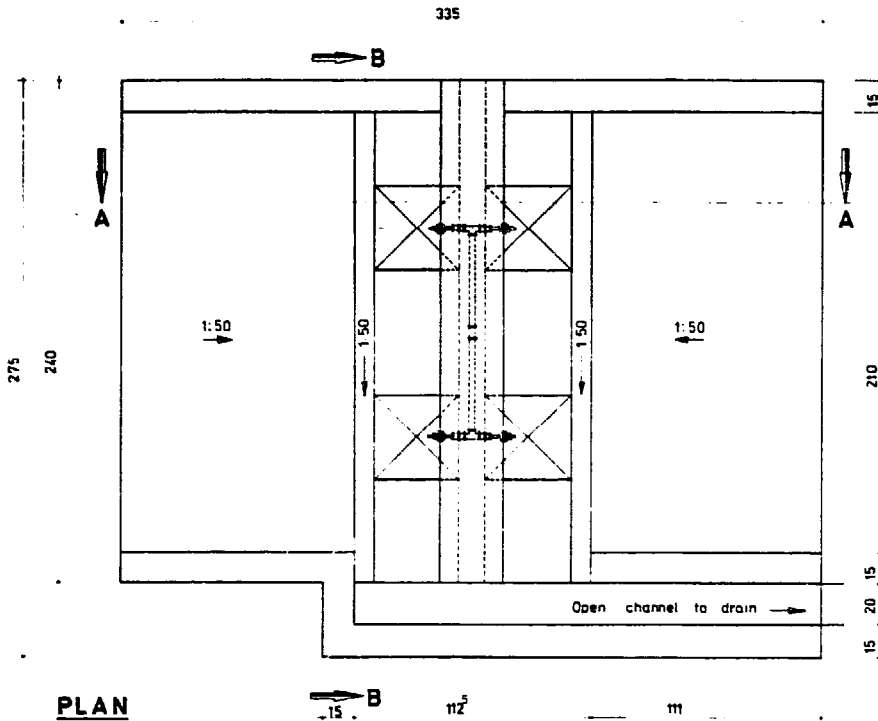

REMARKS

- Dimensions are in centimeters, unless otherwise stated
- Variable sizes should be adjusted to suit local customs and practices
- Cement plaster to be minimum 2 cm thick
- In the absence of a natural drain around the public standpost drainage should be constructed
- Exposed surfaces of concrete to be rubbed over with a mixture of cement and water after removal of shuttering
- All edges to be rounded off or chamfered

PLAN

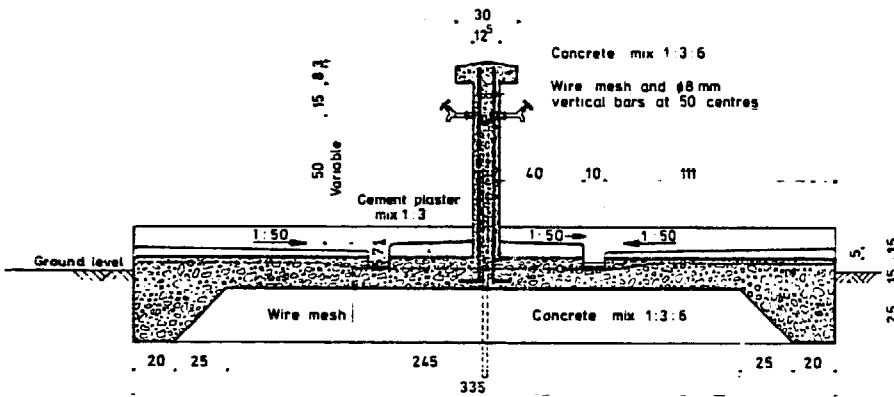

SECTION A-A

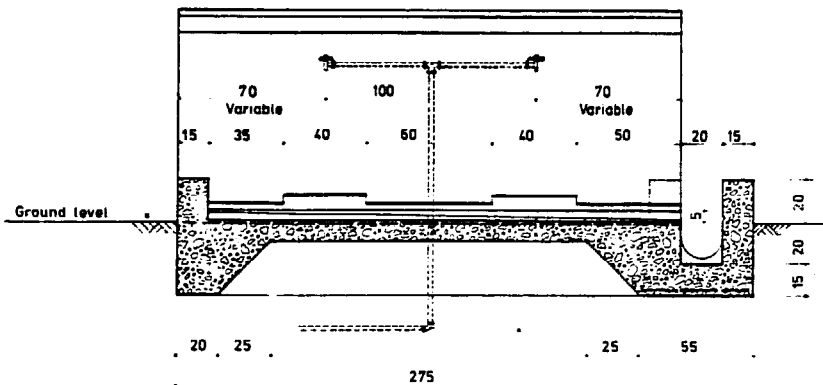

SECTION B-B

FOUR TAP CONCRETE STANDPOST

BILL OF QUANTITIES OF CIVIL WORKS

ITEM	DESCRIPTION	UNIT	QUAN- TITY	UNITPRICE	AMOUNT
1	EXCAVATION	m ³	3.9		
2	FORMWORK PLATFORM, INCLUDING CUTTERS	m ²	8.5		
3	WIREMESH NETTING DIMENSIONS... x ...	m ²	32.8		
4	REINFORCING BARS Ø 8 mm LENGTH TO SUIT	ea	12		
5	CONCRETE PLATFORM MIX 1:3:6	m ³	2.1		
6	FORMWORK WALL	m ²	4.3		
7	CONCRETE WALL MIX 1:2:6 INCL. TROWELLING	m ³	0.3		
8	PLASTERING ON PLAT- FORM, BUCKET STAND AND DRAINGUTTER	m ²	5.7		
9	REFILLING	m ³	1.0		
FOUR TAP CONCRETE STANDPOST					

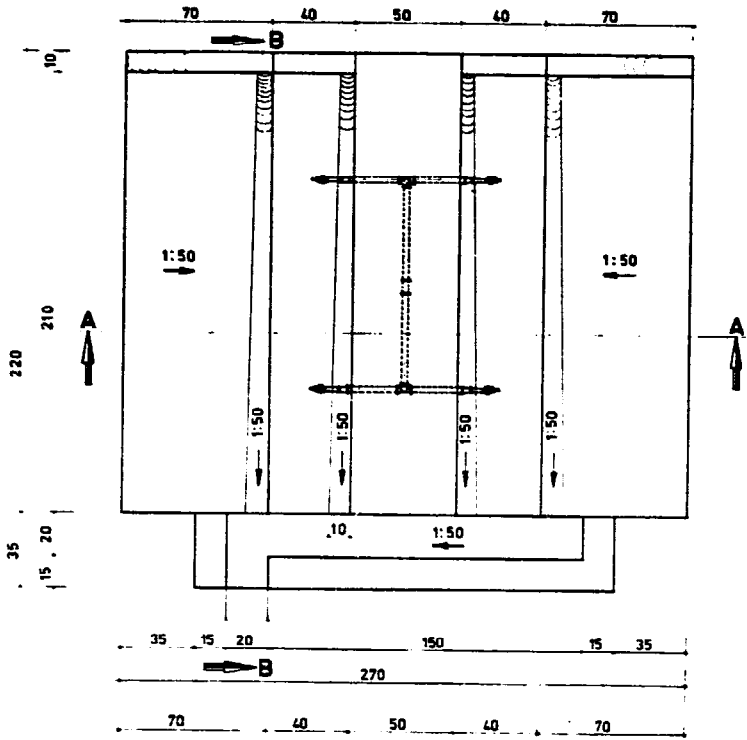

PLAN

REMARKS

- Dimensions are in centimeters, unless otherwise stated.
- All edges to be rounded off.
- Variable sizes should be adjusted to suit local customs and practices.
- Stones should be tooled on exposed faces.
- In the absence of a natural drain around the public standpost, drainage should be constructed.
- Sizes of stones shown on the drawing are only indicative and may be adjusted depending on local availability.

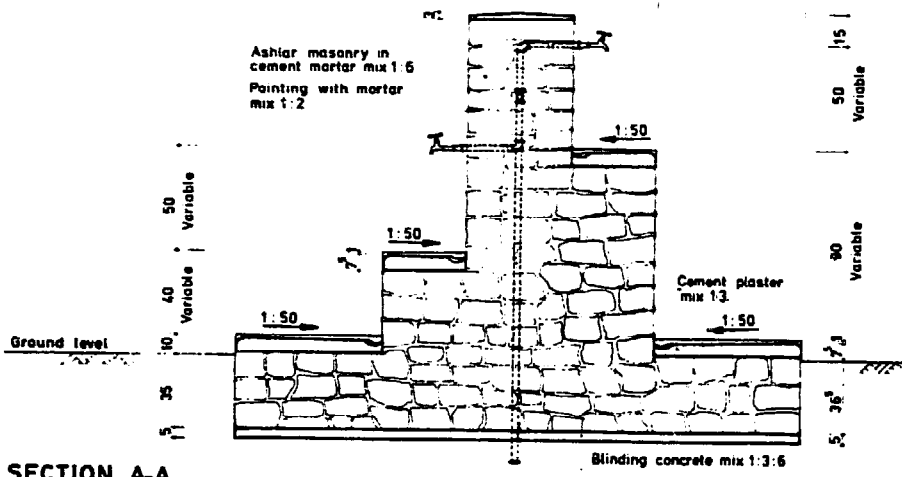

SECTION A-A

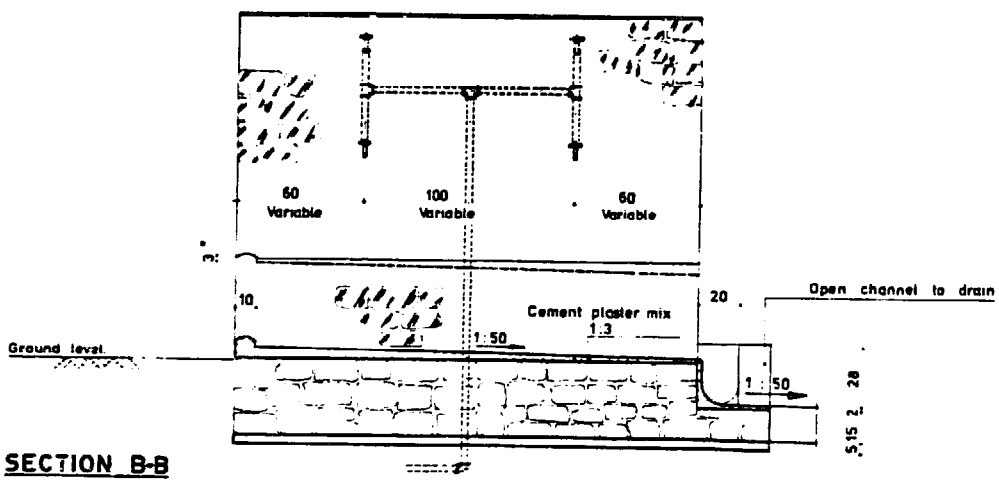

SECTION B-B

FOUR TAP ROCK MASONRY STANDPOST

BILL OF QUANTITIES OF CIVIL WORKS

ITEM	DESCRIPTION	UNIT	QUAN- TITY	UNITPRICE	AMOUNT
1	EXCAVATION	m ³	3.4		
2	BLINDING CONCRETE MIX 1:3:6	m ³	0.3		
3	ROCKMASONRY IN PLASTER MIX 1:3	m ³	4.5		
4	PLASTER ON COLUMN, BUCKET STANDS AND PLATFORM, INCLUDING GUTTERS MIX 1:3	m ²	6.0		
5	POINTING THE MASONRY WITH MORTAR MIX 1:2	m ²	10.0		
6	REFILLING	m ³	1.0		
7	FORMWORK DRAINGUTTER	m ²	1.4		
8	CONCRETE DRAINGUTTER MIX 1:3:6	m ³	0.1		
9	CEMENT MORTAR DRAIN- GUTTER MIX 1:3	m ²	0.4		
FOUR TAP ROCK MASONRY STANDPOST					

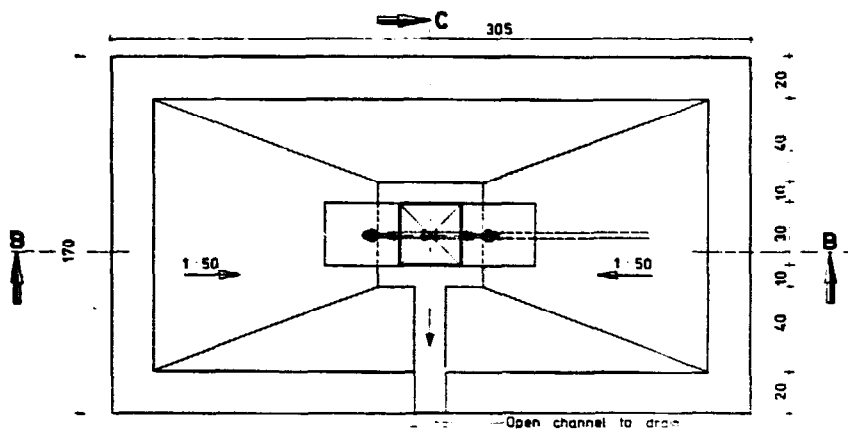

PLAN

SECTION A-A

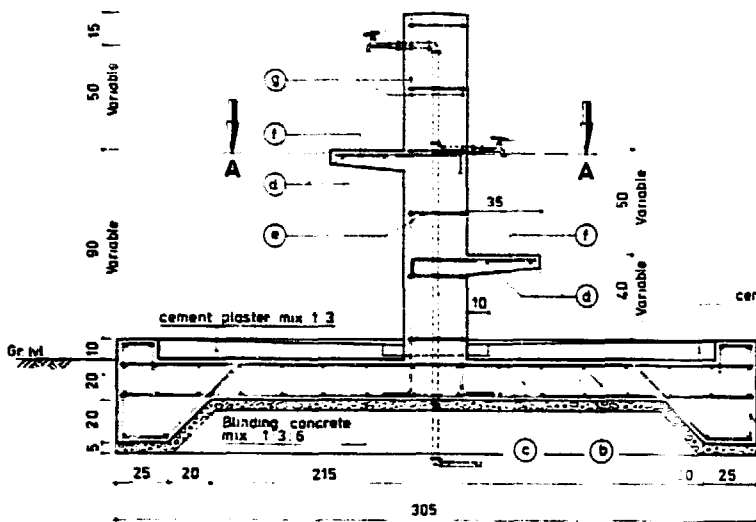
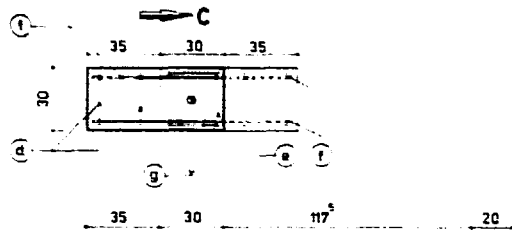

SECTION B-B

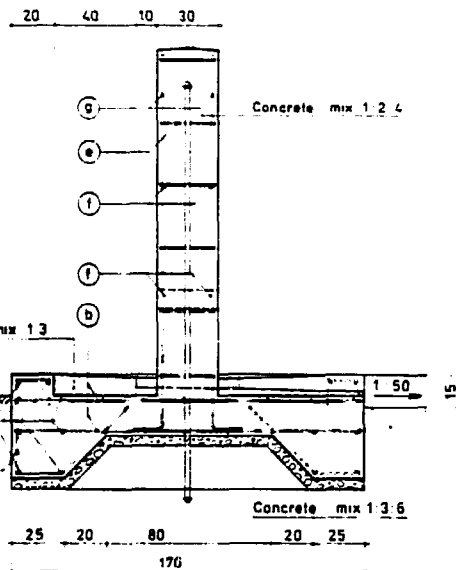

SECTION C-C

BENDING SCHEDULE

bar mark	shape of bars outside dimensions	dia (in mm)	number	length in cm	total length	weight in kg
a		φ 6	34	135	4590	43,8 kg.
b	straight	φ 6	40	165	6600	
c	straight	φ 6	26	300	7800	
d	straight	φ 6	4	25	100	
e		φ 6	6	110	660	6,7 kg.
f		φ 10	4	65	260	
g		φ 10	4	205	820	

- Ⓐ 5φ6-20-L=135cm
- Ⓑ 40φ6-20 L=165cm
- Ⓒ 26φ6-20 L=300cm
- Ⓓ 12φ6-20 L=135cm

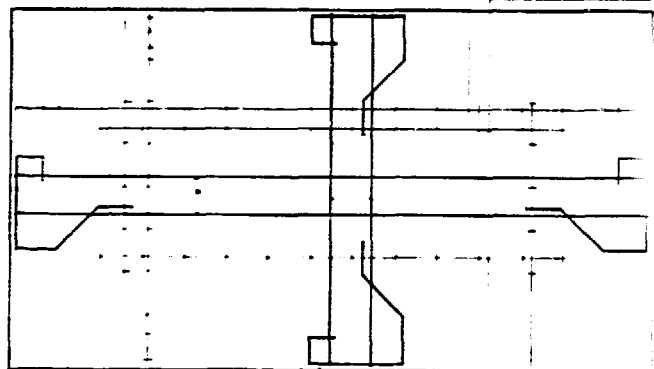

REINFORCEMENT PLATFORM

- Ⓐ 5φ6-20-L=135cm
- Ⓓ 12φ6-20-L=135cm

TWIN TAP REINFORCED CONCRETE STANDPOST

BILL OF QUANTITIES OF CIVIL WORKS					
ITEM	DESCRIPTION	UNIT	QUAN- TITY	UNITPRICE	AMOUNT
1	EXCAVATION	m ³	3.0		
2	BUILDING, CONCRETE, 5 cm, MIX 1:3:6	m ²	5.2		
3	FORMWORK PLATFORM	m ²	5.6		
4	REINFORCEMENT COM- PLETE	kg	50.5		
5	CONCRETE PLATFORM MIX 1:2:4	m ³	1.8		
6	FORMWORK COLUMN AND BUCKET STANDS	m ²	2.3		
7	CONCRETE COLUMN AND BUCKET STANDS MIX 1:2:4	m ³	0.2		
8	PLASTERING ON PLAT- FORM MIX 1:3 INCL. GUTTERS	m ²	3.5		
9	REFILLING	m ³	0.7		
TWIN TAP REINFORCED CONCRETE STANDPOST					

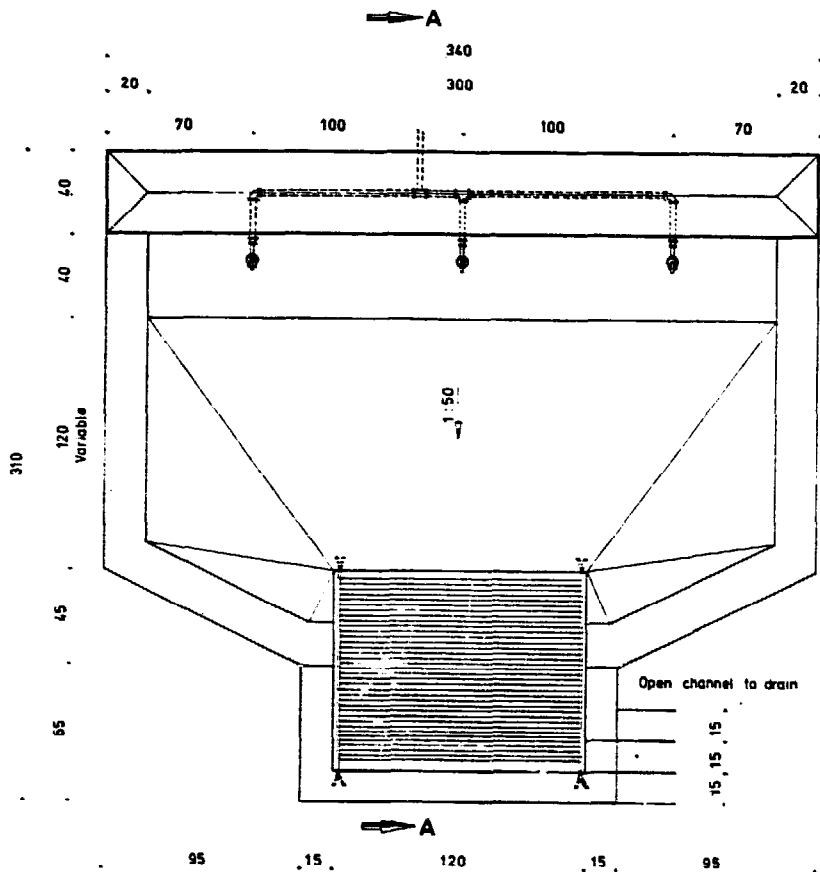

REMARKS

- Dimensions are in centimeters, unless otherwise stated.
- Variable sizes should be adjusted to suit local customs and practices.
- All edges to be rounded off.
- All brickwork to be cement plastered 15-25 cm.
- In the absence of a natural drain around the public standpost drainage should be constructed.
- Cattle grid should be painted with red oxide paint and lead paint.

PLAN

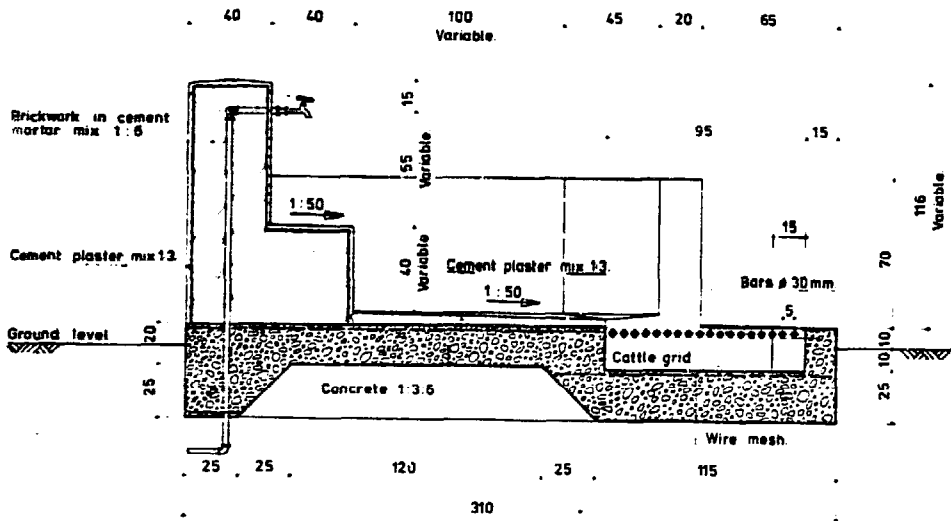

SECTION A-A

THREE TAP CONCRETE / BRICKWORK CATTLE PROTECTED STANDPOST

BILL OF QUANTITIES OF CIVIL WORKS					
ITEM	DESCRIPTION	UNIT	QUAN- TITY	UNITPRICE	AMOUNT
1	EXCAVATION	m ³	3.7		
2	FORMWORK PLATFORM INCLUDING PIT	m ²	7.2		
3	WIREMESH NETTING DIMENSIONS... x ...	m ²	10.0		
4	CONCRETE PLATFORM MIX 1:3:6	m ³	2.8		
5	BRICKWORK IN CEMENT MORTAR MIX 1:6 FOR WALLS AND BUCKET STAND	m ³	3.0		
6	PLASTERING ON WALLS, PLATFORM AND BUCKET STAND MIX 1:3	m ²	22.0		
7	CATTLE GRATE, INCL. MOUNTING	ea	1		
8	REFILLING	m ³	0.6		
THREE TAPS CATTLE PROTECTED STANDPOST					

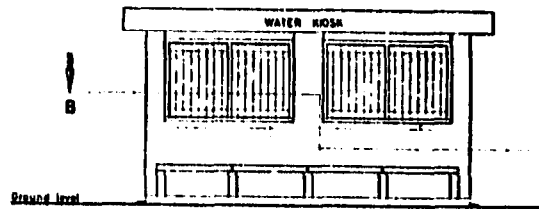

FRONT ELEVATION

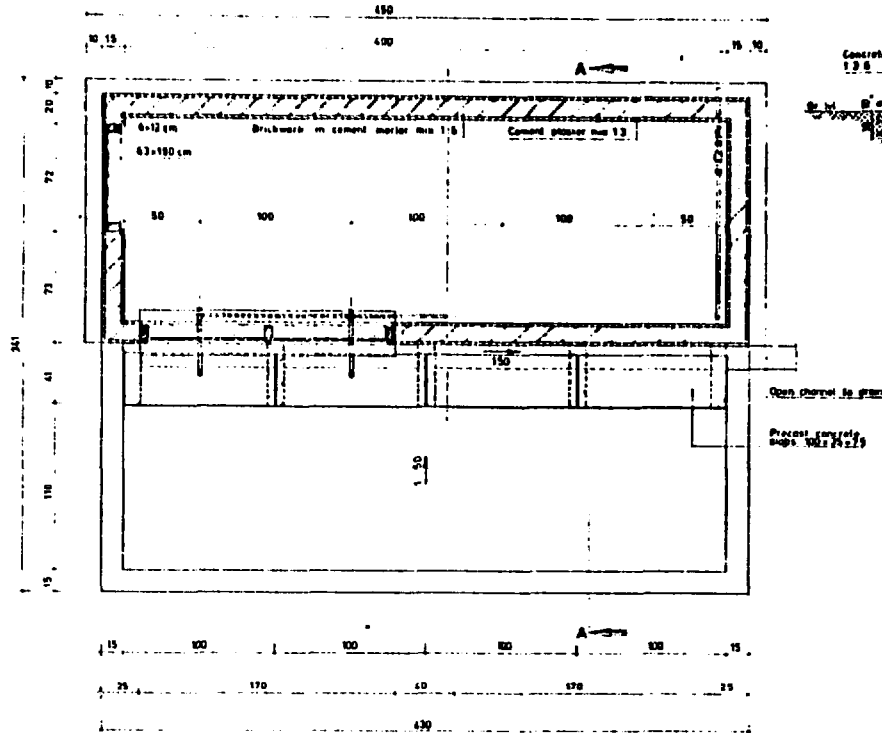

SECTIONAL PLAN B-B

WATER KIOSK WITH FOUR TAPS

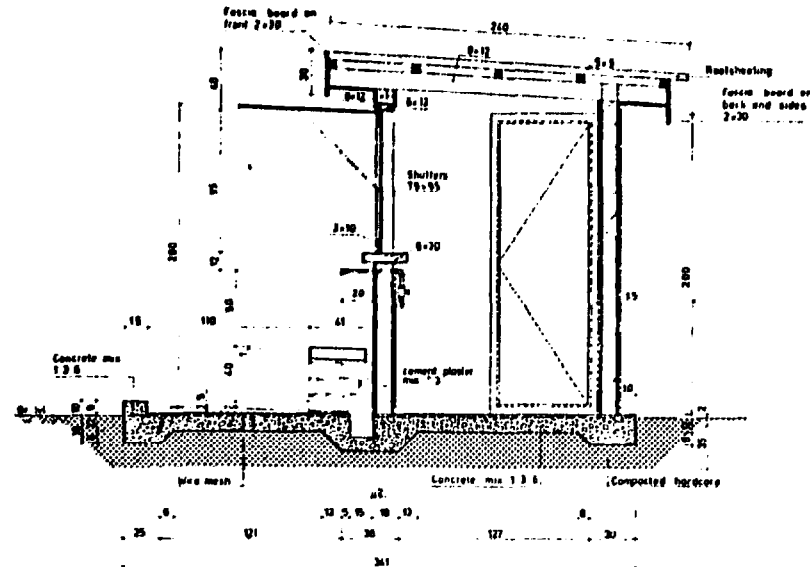

SECTION A-A

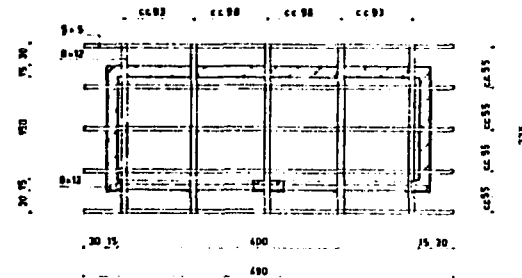

ROOF DETAIL

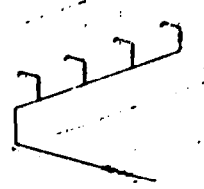

SCHEMATIC LAYOUT OF PIPEWORK



REMARKS

- Dimensions are in centimeters, unless otherwise stated
- Where a variety of construction materials are used, dimensions of structure should be changed accordingly
- All edges to be rounded off
- In the absence of a natural drain around the kiosk drainage should be constructed
- Depth of foundation to be decided on site



8mm 20mm bars each 92 long
8mm 20mm bars at 20cm each 32 long

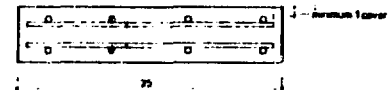

PRECAST CONCRETE SLAB DETAIL

BILL OF QUANTITIES OF CIVIL WORKS

ITEM	DESCRIPTION	UNIT	QUAN- TITY	UNITPRICE	AMOUNT
1	EXCAVATION	m ³	7.0		
2	WIREMESH NETTING FOUNDATION SLABS DIMENSIONS .. x .. mm	m ²	15.0		
3	COMPACT HARDCORE 20 cm	m ²	22.0		
4	EVT. REFILLING WITH CLEAN SAND	m ³	--		
5	FORMWORK FLOORSLAB INCLUDING GUTTERS	m ²	6.2		
6	REINFORCEMENT FLOOR WIRE MESHNETTING DIMENSIONS .. x .. mm	m ²	14.6		
7	CONCRETE FLOOR MIX 1:3:6	m ³	3.5		
8	BRICKWORK WALLS WATER- KIOSK, INCL. BUCKET- STAND IN CEMENT MOR- TAR MIX 1:6, 15 cm THICK	m ²	20.0		
9	FRAMEWORK SHUTTERS AND DOOR, INCL. SHUTTERS, DOOR, IRON- MONGERIES ETC.	--	--		
10	ROOFCONSTRUCTION WITH ALL NECESSARY BEAMS AND ROOFSHEETING INCL. FASTENINGS	--	--		
11	PLASTERING ON WALLS, PLATFORM AND BUCKET STAND WITH CEMENT MORTAR MIX 1:3	m ²	46		
12	PAINTING OF KIOSK	--	--		
13	REFILLING	m ³	2.5		
14	PRECAST CONCRETE SLABS 100 x 75 x 35 mm INCL. REINFORCEMENT	ea	4		
WATER KIOSK WITH 4 TAPS					

ANNEXES

LIST OF ANNEXES

1. Symbols and abbreviations
2. Units and conversion
3. Growth factor
4. Service radius
5. Pressure head losses
6. Hydraulic equations
7. Stopcock and watermeter
8. Materials
9. Standpost drainage
10. Flow control mechanism
11. List of references

SYMBOLS AND ABBREVIATIONSSYMBOLS

A	=	area (m ²) or (ha)
a	=	maximum walking distance
Cd	=	average demand per capita (l/d)
D	=	internal diameter of pipe (m) or (mm)
f	=	efficiency factor of a tap
g	=	gravity factor (m/s ²)
H	=	head, pressure head, headloss (mhw)
Ha	=	available head
i	=	hydraulic gradient
k	=	roughness factor (m)
L	=	length (m)
m	=	growth factor
N	=	design population
No	=	initial population
n	=	number of users per standpost
P	=	peak factor
p	=	pressure (mhw)
Q	=	flow rate (m ³ /s) or (l/h)
Qmax	=	required maximum discharge capacity (l/h)
qspec	=	specific flow rate (m ³ /s)
R	=	service radius (m)
r	=	annual growth rate of population (%)
S	=	number of standposts
T	=	design period
t	=	number of peak hours
v	=	velocity (m/s)
w	=	wastage factor
λ	=	coefficient in hydraulic gradient i
ρ	=	specific density (kg/m ³)
π	=	3,14
≥	=	equal to or larger than
≤	=	smaller than or equal to
*	=	multiplied by

ABBREVIATIONS

GS	=	galvanized steel
PVC	=	polyvinylchloride
lcd	=	litres per capita per day
mhw	=	meter head of water

UNITS AND CONVERSION

In principle Standard International (SI) units are used in this publication. In addition to that, however, and as a compromise towards the daily practice in the drinking water world, some well known units (such as cm, mhw, l/h and inches) are used as well, where this does not harm the accuracy of calculations. In this relation reference is made to the advice of the International Water Supply Association (IWSA) regarding the application of SI units in the field of water supply and sanitation.

UNITS

Length	meter	m
Area	square meter	m ²
Volume	cubic meter	m ³
Time	second, hour	s, h
Mass	kilogram	kg
Force	Newton	N
Pressure	kilogram force	kgf/cm ³
Work, Energy	Joules	J
Power	Watt	W
Velocity	meter per second	m/s
Flow	cubic meter per second	m ³ /s

ADDITIONAL UNITS

cm = centimeter = 0,1 m = 10 mm

mhw = meter head of water

$$1 \text{ mhw} = 10^3 \text{ mm H}_2\text{O} = 9.807 \cdot 10^3 = 0,1 \text{ kgf/cm}^2$$

Pa = N/m² is a relatively small unit and had the disadvantage of requiring large numbers in calculation; besides the mhw is visually attractive.

l/h = liter per hour, a relevant unit regarding domestic use of water.

inch = imperial equivalent for 25,4 mm; with regard to standardization equipment often used for procurement.

CONVERSION OF IMPERIAL EQUIVALENTS TO SI UNITS

1 inch	= 25,4 mm	1 cu. inch	= 16387 mm ³
1 foot	= 0,305 m	1 cu. foot	= 0,028 m ³
1 yard	= 0,914 m	1 cu. yard	= 0,765 m ³
1 acre	= 4047 m ²	1 gallon	= 0,005 m ³

GROWTH FACTOR AS A FUNCTION OF A DESIGN PERIOD AND THE ANNUAL
POPULATION GROWTH RATE IN PERCENTAGE

Design Period in years	Annual population growth rate in %					
	0	2	3	4	5	10
0	1.00	1.00	1.00	1.00	1.00	1.00
5	1.00	1.00	1.16	1.22	1.27	1.61
10	1.00	1.22	1.34	1.48	1.63	2.59
15	1.00	1.35	1.56	1.80	2.08	4.18
20	1.00	1.45	1.81	2.19	2.65	6.83

The growth factor (m) depends on the annual growth rate (r) and the design period (T): $m = \{1+r\}^T$.

In general the growth factor will be in the range of 1.0 to 1.6.

THE SERVICE RADIUS AND THE MAXIMUM WALKING DISTANCE

Assume that the total area A is divided into a number of circular "standpost service-areas" of equal magnitude and arranged in such a way that the sum of the surface area of all service areas equals the total surface of area A. Say, there are S standposts and R is the radius of the service area. The above is then expressed by the following equation:

$$A = S * \pi R^2$$

This hypothetical situation can be imagined as follows:

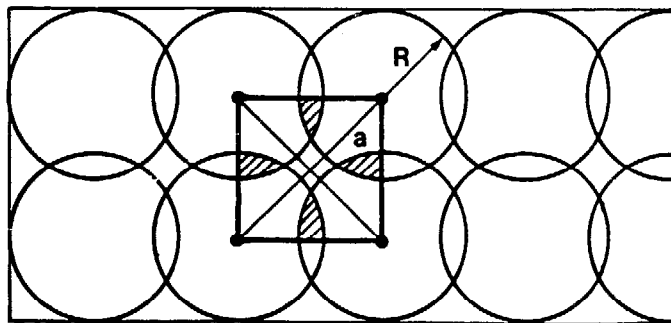

The above equation is only valid if the sum of the surfaces of the "overlapping circular areas" just equals the sum of the surfaces of the areas that are not covered by one of the circular service-areas. In this case the surface of the square just equals the surface of a circular area.

The maximum walking distance (a) be calculated as follows:

$$2a^2 = \pi R^2 \rightarrow a = \sqrt{\pi/2} \cdot R = 1,253 R.$$

The equation $A = S * \pi R^2$ is often used to assess the number of standposts S required for a particular area A, assuming a service radius R. As shown above R is not exactly equal to the maximum walking distance, but is a good representation of the maximum walking distance of the majority of the population in a particular area.

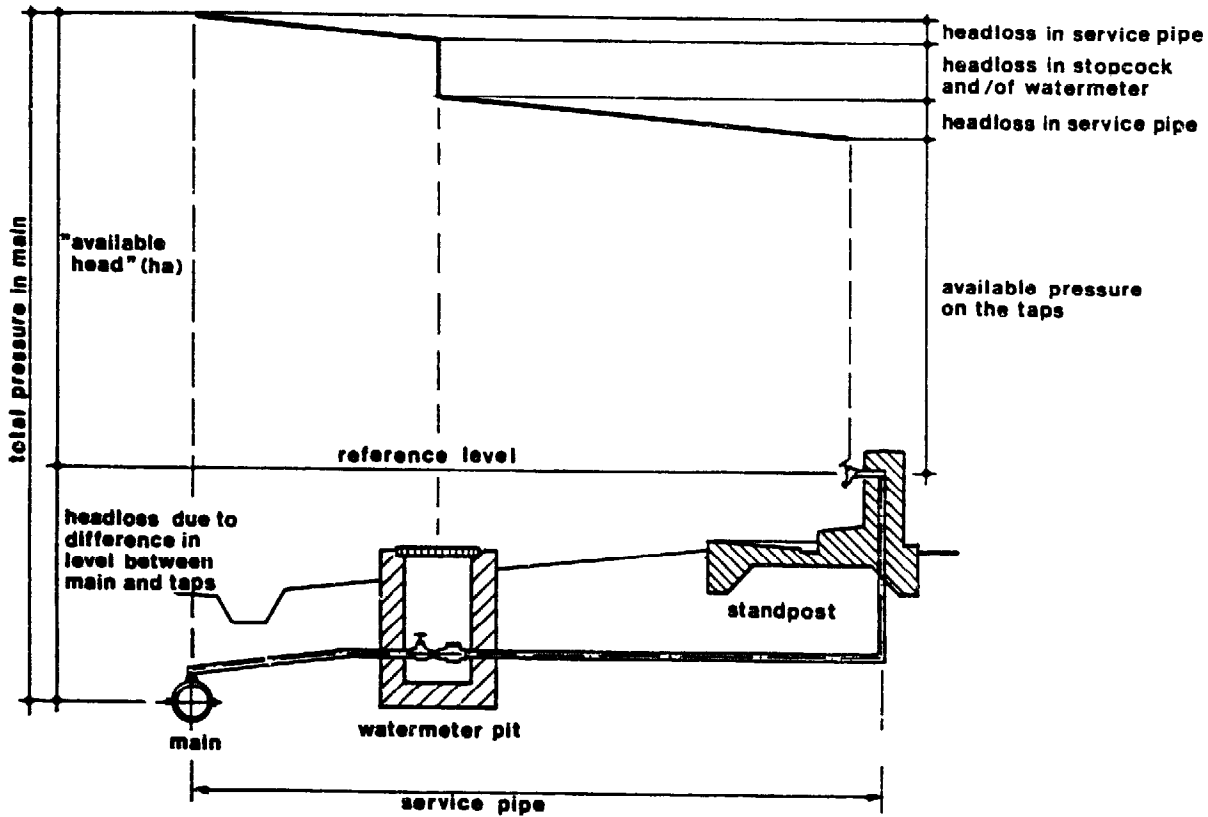
PRESSURE HEAD LOSSES DUE TO THE FLOWING OF THE WATER

This diagram illustrates:

- a) the difference in level between the main and the taps
- b) the total length of service pipe being greater than the direct horizontal distance (the possible deviation in the horizontal plan has also to be taken into account).

HYDRAULIC EQUATIONS1. Equation of Bernoulli:

$$H = \frac{v^2}{2g} + \frac{P}{\rho g} + Z$$

H = Total energy level ("total head")

$\frac{v^2}{2g}$ = head related to the velocity of the water

$\frac{P}{\rho g}$ = pressure head, being the pressure in the water

Z = level in relation to a reference level

When the water in a pipe is in rest ($V=0$) the total head is only determined by the pressure head and the level.

2. Hydraulic Gradient

$$i = \lambda \frac{1}{D} \cdot \frac{v^2}{2g} \quad \text{in which} \quad v = 4Q/\lambda D^2$$

$$\lambda = 0.25 / \left\{ \log \frac{3.7D}{k} \right\}^2 \quad \text{and}$$

$$k = \text{roughness coefficient}$$

The coefficient k is directly related to the kind of material. For galvanised steel (GS): $k = 0.001$ and for polyvinylchloride (PVC): $k = 0.0001$.

3. Definitions:

Hydraulic: "of water *flowing through pipes and channels*".

Hydrostatic: "of the equilibrium of liquids and the pressure exerted by liquids *at rest*".

STOPCOCK (VALVE) AND WATERMETER

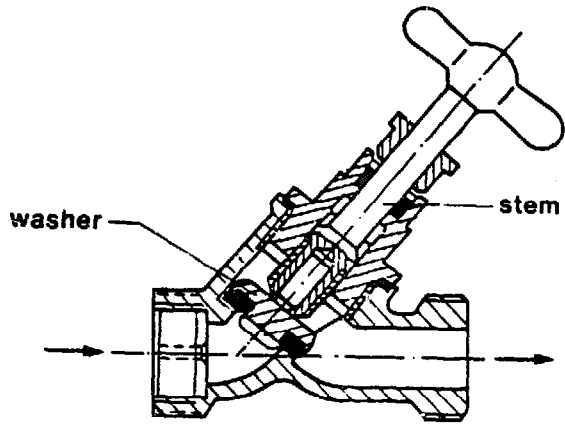

STOPCOCK

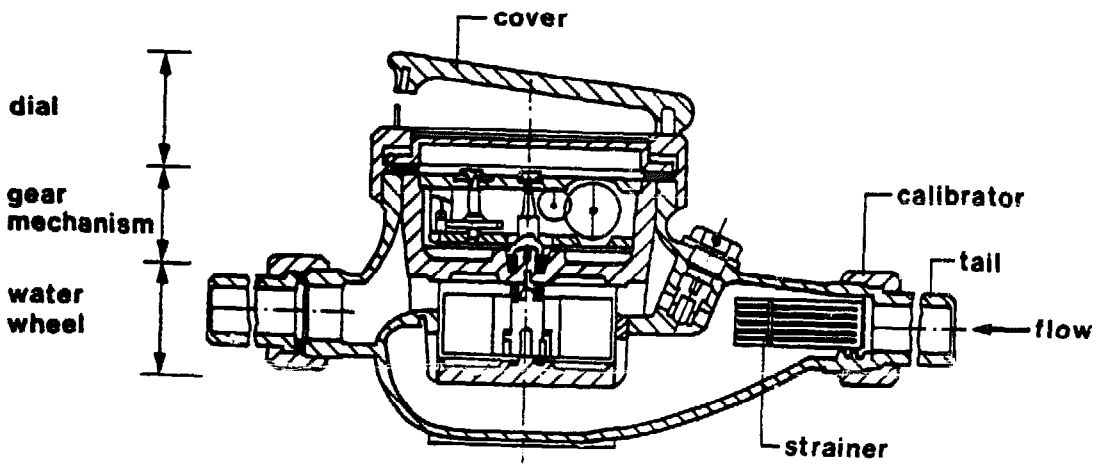

WATERMETER (dry dial)

MATERIALS AND EQUIPMENT COMMONLY APPLIED
IN WATER SUPPLY SYSTEMS

MATERIALS AND EQUIPMENT COMMONLY APPLIED IN WATER SUPPLY SYSTEMS

parts of system Materials	distribution pipes	connection of distribution pipe to ser- vice pipe		service pipe	stop- cock	water- meter	taps or valves	pipe joint	remarks
		saddle	ferrule						
Steel	*	*	-	-	-	-	-	welded or couplings	
Galvanised steel (gs)	***	*	-	***	-	-	-	welded sockets	
cast or ductile iron	***	**	*	-	**	-	**	ball and socket	
polyvinylchloride (pvc)	**	***	-	***	**	-	*	sockets	
polyethylene (pe)	*	-	-	*	-	-	-	welded or brass/cast iron	
asbestos cement (ac)	**	-	-	-	-	-	-	coupling sockets	
brass	-	-	***	-	**	***	***	-	
nylon	-	-	-	-	-	-	*	-	

*** = often applied
** = regularly applied
* = rarely applied

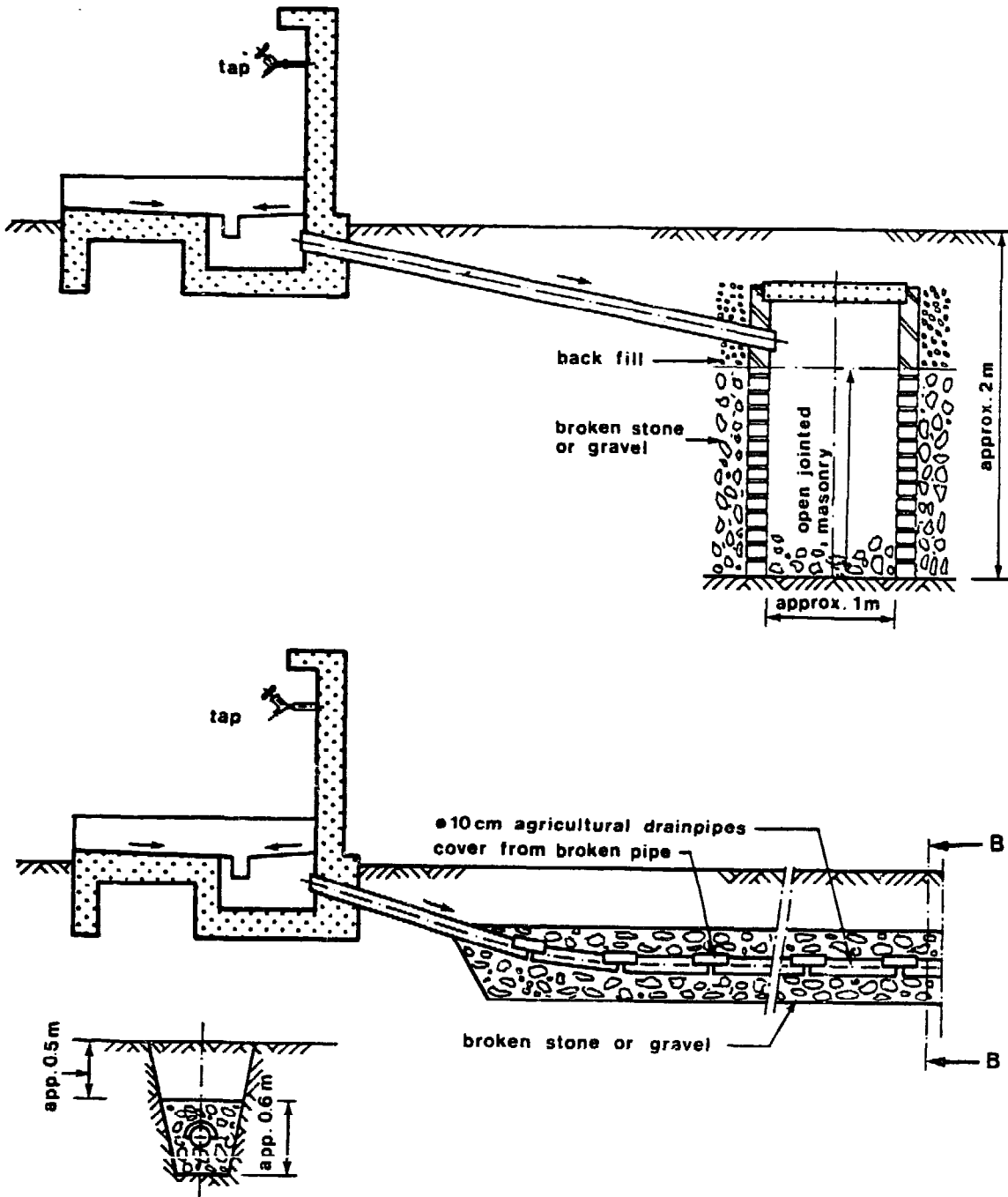
STANDPOST DRAINAGE

Agricultural drainage-tiles laid in a 'soak-away' trench (unless a more accurate figure is known, the rate of infiltration per m² of sidewall area may be estimated as 10 l/d).

FLOW CONTROL MECHANISMS

- A. *SCREW TAPS*, such as the ordinary household type, have many advantages including simplicity of maintenance, and will probably be the most widely chosen. The valve washer in metal taps must be replaced regularly to prevent leakage, but this task is well within the capability of a local caretaker. The amount of wear on the washer and on other parts depends on how the tap is used, and whether it is sometimes closed too tightly. However, once people have become used to the device, and if necessary have been given instruction in its use, there should be no major problems.

Screw taps may be of brass, iron or plastic. Brass taps are often stolen because of the value of the material and can be easily screwed off the end of the pipe unless welded to it. Experience with nylon taps which have nylon valve-seats has been quite good, and less wear has occurred than in metal taps.

There are, of course, many types and brands of screw taps on the market. Small details like the quality of washers and finish of seats can be very important for the amount of maintenance the tap will require.

- B. *TAPS WITH A BALL VALVE* appear to offer some advantages, because the closing pressure is not dependent on the force exerted by the user. Thus wear should vary less, and there are no small washers which require frequent changing. Some authorities suggest that such taps are more prone to leaking than well-maintained screw taps. Generally, they give rise to a lower head loss and so provide an adequate rate of flow even when water pressure is relatively low.

A. SCREW TAPS

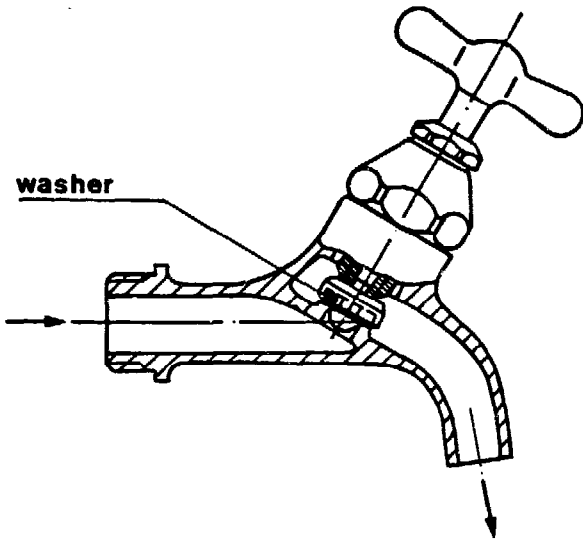

A1: ORDINARY SCREW TAP
IN CLOSED POSITION

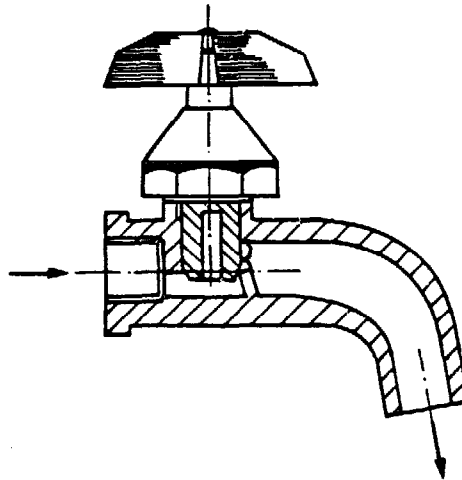

A2: NYLON TAP IN
CLOSED POSITION

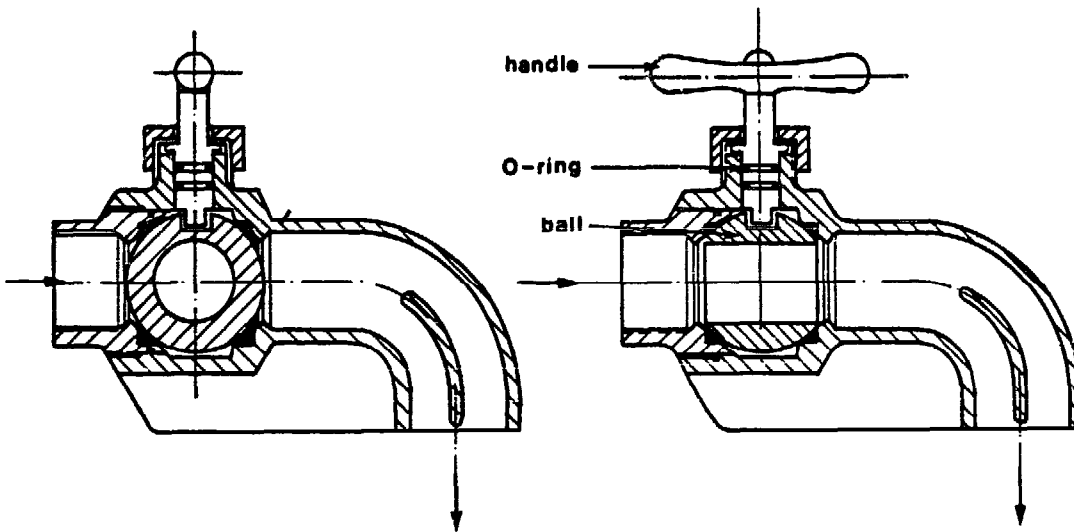

B1: IN CLOSED POSITION

B2: IN OPEN POSITION

- C. *SPRING-LOADED OR GRAVITY-OPERATED TAPS* are devices with which the user has to apply some force with the hand in order to keep the water flowing. They appear to be an attractive option for unsupervised standposts where it is of special importance that water waste be avoided. The tap is closed by spring action or by gravity immediately the user's hand is removed.

These taps are relatively cheap, simple to operate and present no complex maintenance problems. However, their value in reducing waste is not always as great as might appear, because they are sometimes kept open by means of a rope, wire or stone attached to the handle.

The gravity-operated tap is widely used in India. It has a heavy mouthpiece which must be pushed up to open the tap. It falls back as soon as the user ceases to hold it.

- D. *VOLUMETRIC OR DELAYED-CLOSING TAPS* are similar to spring-loaded taps, but have a more complex mechanism which keeps the tap open for a fixed period of time after the handle has been operated. The tap cannot be held open by weights because it closes after the fixed time interval even when pressure is continually applied. To re-open the tap, the handle or knob has to be operated again.

Such taps may be the most effective at reducing wastage at unsupervised standposts, but they are complicated devices requiring regular maintenance by skilled staff. But it should also be noted that delayed-closing or spring-loaded taps are not always very acceptable to users. Some require considerable force to operate, and it is not excluded that they cause minor injuries when not operated properly.

C. SPRING-LOADED OR GRAVITY-OPERATED TAPS

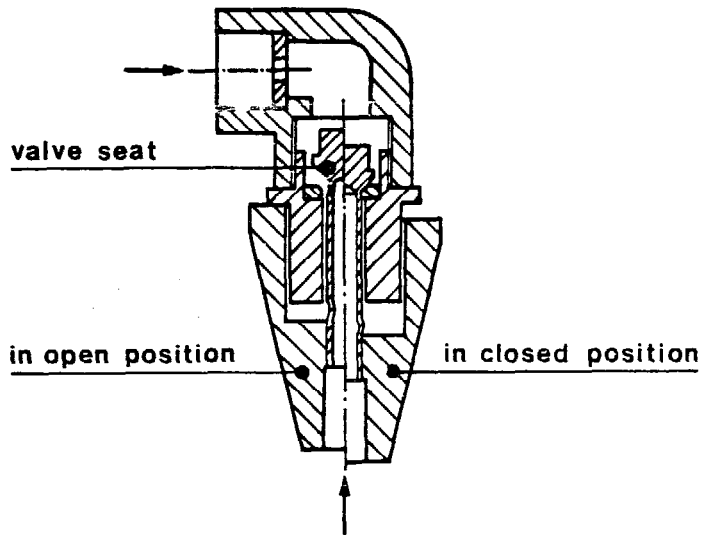
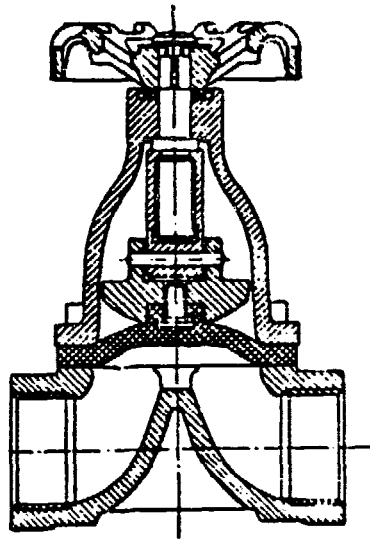

GRAVITY OPERATED TAPS
(Jayson (Pat) Water Taps)

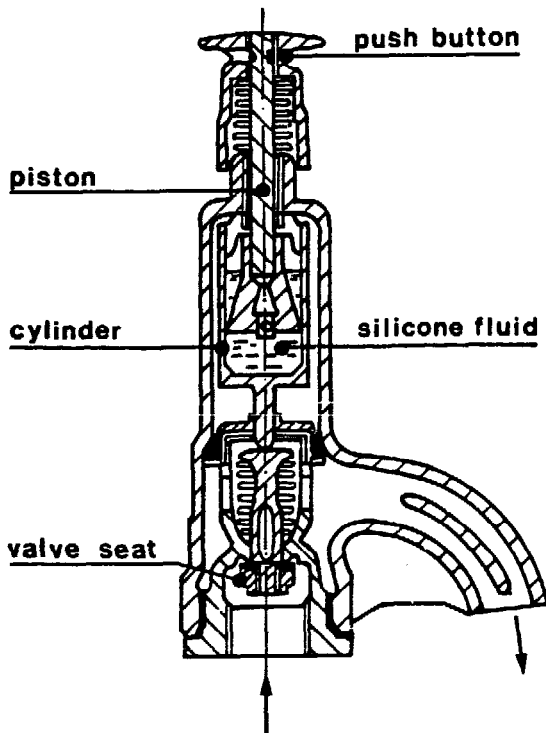

D1: SELF CLOSING TAP
(Fordilla)

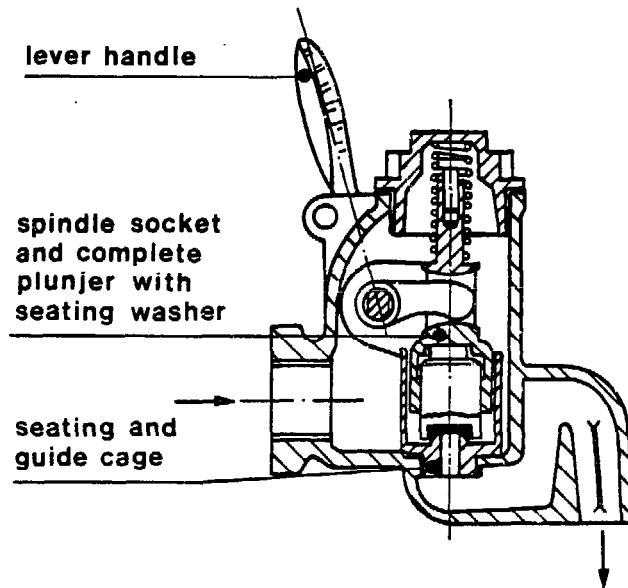

D2: SELF CLOSING TAP
(Tylor wastenot)

The definition of *a tap* is that of a closing device at the end of a pipe, whereas *a valve* is fitted in a pipeline.

- E. A *DIAPHRAGM VALVE* has a body made of either cast iron or polyvinylchloride and a diaphragm usually constructed of neoprene or teflon. The advantages of the diaphragm valve are low pressure losses in comparison with taps; the separation of the operation mechanism from the water by the diaphragm; the glandless construction of the operating mechanism and the low maintenance requirements during its working life.

LIST OF REFERENCES

BACHMANN, A.

Manual for Water Systems and Pipe Work

A brief introduction course for the establishment of rural water supplies in Nepal.

Swiss Association for Technical Assistance (SATA), Katmandu.

BORJESSON, E.K.G.; BODEDA, C.M.

New Concept in Water Service for Developing Countries

Journal of the American Water Works Association, 56, 1964, pp. 853-862.

FAIR, G.M.; GEYER, J.C.; OKUN, D.A.

Water and Wastewater Engineering, Vol. I: Water Supply and Wastewater Removal

John Wiley and Sons, Inc., New York, 1966.

JOHNSON, C.R.

Village Water Systems, Standards and Procedures for the Design of Water Supply Systems in Rural Areas of Nepal and Bhuthu

UNICEF, Katmandu, Nepal, 1976.

LAURIA, D.T.; KOLSKY, P.J.; MIDDLETON, R.N.

Design of Low-cost Water Distribution Systems

P.U. Report No. RES11, Energy, Water and Telecommunications Department, The World Bank, Washington D.C., 1977.

PITCHAI, R.

Water Distribution - Problem and Discussion

Paper presented at the Seminar on Improvement and Maintenance of Existing Water Supply Systems, Manpur, U.P., India, 1978.

World Health Organization, Regional Office for South-East Asia.

TASGAONKAR, S.K.

Norms for Design of Rural Pipes Water Supply Schemes

Journal of the India Water Works Association, January/March 1978, pp. 97-102.