

WHO
International Reference Centre
for
Community Water Supply

November 1979

The Hague, The Netherlands

Public Standpost Water Supplies

13

Technical Paper Series

The International Reference Centre for Community Water Supply (IRC) is based on an agreement between the World Health Organization and the Netherlands' Government. The general objective of the IRC is to underpin information and technology support programmes in developing countries in the field of community water supply and sanitation and to promote international cooperation therein. Acting as a catalyst, the IRC operates through a worldwide network of regional and national institutions, as well as with international agencies, bilateral donors, non-governmental organizations and individuals.

Requests for information on the IRC, or enquiries on specific problems may be directed to the International Reference Centre for Community Water Supply, Information Section, P.O. Box 140, 2260 AC Leidschendam, the Netherlands.

AT MICROFICHE
REFERENCE
LIBRARY

A project of Volunteers in Asia

Public Standpost Water Supplies, Technical Paper #13

Published by:

IRC
P.O. Box 5500
2280 HM Rijswijk
THE NETHERLANDS

Available from:

same as above

Reproduced by permission.

Reproduction of this microfiche document in any form is subject to the same restrictions as those of the original document.

WHO INTERNATIONAL REFERENCE CENTRE
FOR
COMMUNITY WATER SUPPLY

PUBLIC STANDPOST
WATER SUPPLIES

TECHNICAL PAPER NO. 13
NOVEMBER 1979

Nw. Havenstraat 6, 2272 AD Voorburg (The Hague)
The Netherlands

Postal Address:
P.O. Box 140, 2260 AC Leidschendam, The Netherlands

This report is issued on the responsibility of the WHO
International Reference Centre for Community Water Supply.
It does not necessarily represent the decisions or the
stated policy of the World Health Organization.

TABLE OF CONTENTS

	<u>Page</u>
PREFACE.....	5
ACKNOWLEDGEMENT.....	7
SUMMARY.....	9
I. INTRODUCTION.....	15
II. ECONOMICS AND FINANCE	
General Considerations.....	21
Cost of Standpost Systems.....	23
Selection of Design Standards.....	26
Financing.....	28
III. SOCIAL ASPECTS	
Social Appropriateness.....	35
Planning and Social Acceptability.....	36
Social Organization.....	42
IV. ORGANIZATION AND MANAGEMENT	
Institutional Structure.....	45
Staff Requirements and Training.....	49
Operation Management.....	51
- Maintenance.....	52
- Supervision.....	57
- Revenue Collection.....	58
V. COMMUNITY PARTICIPATION	
Participation in the Planning.....	61
Implementation.....	63
Participation in Operation and Maintenance.....	64
Use of Water and Improvement of Health.....	66
Community Organization.....	68
V. TECHNICAL ASPECTS	
Choice of Technology.....	71
Water Consumption.....	72
Hydraulics and Capacities.....	73
Standpost Structure and Layout.....	77
ANNEXES.....	81
LIST OF REFERENCES.....	95
INDEX.....	101



WATER COLLECTION

PREFACE

Recognizing the fundamental importance of water supply and sanitation in the promotion and socio-economic development, member countries of the United Nations Organizations have declared the period 1981 - 1990 as the International Drinking Water and Sanitation Decade. The goal is to provide all people with an adequate supply of safe water and sanitary disposal of human excreta by the end of the Decade. If this goal is to be achieved, some two billion (2 000 000 000) people should be provided with water by the end of the Decade at an estimated cost of about 60 billion dollars, based on existing per capita costs. With this estimate it can be anticipated that cost is likely to be one of the major constraints in the achievement of the Decade targets. It is therefore imperative that the visions of the best but costly options of water supply are not allowed to distract communities from the attainable. Undoubtedly, each community would have liked to be provided with pipe-borne water supply with full house connection. Yet for most communities in the developing countries this would be unaffordable. For many a community the affordable and realistic solution which would be at the same time technically sound would be the public standpost water supply system. As a guide for the proper planning of such systems the present publication would be invaluable.

It used to be assumed that the provision of a community with an adequate and safe water supply would, by itself, be followed by certain health and socio-economic benefits. But the evaluation of some water supply projects has shown that such expected benefits do not necessarily follow because due to socio-cultural and managerial problems, the installed water supplies may not be used as anticipated. The present publication seeks to provide the reader with the necessary guidance for overcoming such problems.

It provides insights not only into the economic and financial aspects of the planning of public standpost systems, but also into its social, organizational and managerial aspects. It also deals with community participation in technology selection, operation and maintenance. This is, in effect, a publication on the software of public standposts. The hardware is treated more extensively in the companion volume entitled "Design Manual" (IRC Technical Paper No. 14).

The present publication will be of particular interest to decision makers, planners, administrators, public health workers and engineers responsible for the planning and implementation of public standpost water supplies.

ALBERT WRIGHT

ACKNOWLEDGEMENT

This publication is the result of a collaborative effort. Grateful acknowledgement is extended towards Dr. D.T. Lauria, Mr. A.K. Roy, Mr. K.B. Ringskog and Dr. A.T. White, for their contributions on respectively, the technological, organizational, economic and social aspects of public standpost water supply systems.

This report also incorporates material reviewed in an international expert meeting held in Achimota, Ghana, in August 1977. The participants offered many useful comments and suggestions and their help is greatly appreciated.

A special word of thanks is addressed to Albert Wright, Professor at the University of Kumasi, Ghana, for his active support and collaboration, and to Arnold Pacey, who did admirable work regarding the editing of the various contributions. Last but not least, the much appreciate assistance of Marylynn Bianco and Dick Mos in the finalization of this Technical Paper is gratefully acknowledged.

This publication and its companion "Design Manual" (IRC Technical Paper No. 14; results from a study commissioned by the World Bank. The IRC wishes to take this opportunity of thanking the Bank, and in particular, Messrs. H. Shipman and J.M. Kalbermatten for their continuous support to this study.

Enric L.P. Hessing
Programme Officer



PUBLIC STANDPOST WATER SUPPLY

SUMMARY

Public standposts are often installed as a first step in the development of a full house-connected water supply. For many people in developing countries, however, a public standpost could well be the only feasible water supply for a long time to come; particularly in rural areas, where scattered housing makes individual connections extremely expensive, and in low-income urban fringe areas, where little revenue can be expected in return for public services.

In the planning of public standpost water supplies, many technological, economic, organizational and socio-cultural aspects have to be taken into account, in conjunction with each other. The inter-relationships between the organizational structure, the choice of technology, the financing and revenue collection, the operation and maintenance, community participation and local organization, requires an integrated approach towards the planning of public standpost water supplies.

The decision to install public standposts is largely determined by economic and financial considerations. However, many other factors influence the decision as well, and a systematic analysis of all relevant factors is needed to determine what level of service is economically and socially appropriate.

The circumstances in which public standposts are commonly used may be summarized as follows:

- where funds for investment in water supplies are severely limited;
- in rural areas where house connections would require lengthy and expensive runs of pipe;
- in urban slums where improvements in housing are needed before individual house-connections are feasible.

Public standposts are economically appropriate mainly where investment funds are severely limited. The capital investment necessary to set up a public standpost water supply is considerably less than that required for a full house-connected supply, particularly when the size of the community served is smaller than 5000.

However, the cost per unit volume of water from public standposts is relatively high, due to the lower consumption rate per head. The total cost of a public standpost water supply varies greatly, depending on sources works, treatment and length of piping required. The cost of the standpost itself is a relatively small amount, but also varies greatly for different countries and situations. It ranges from US\$ 20-50 for a very simple standpost used in rural villages, to US\$ 200-500 for public standposts in urban settings.

To secure the necessary government or private investment cooperation, it is useful to reinforce health benefit and cost effectiveness arguments with a demonstration of the consumers' willingness to pay for the water and to contribute towards the cost of construction, operation and maintenance. Therefore, it is essential to establish a clear charging policy and to develop an appropriate method of revenue collection.

In many cases, a suitable arrangement could be to meet the costs partly from house connection charges and partly from a general water tax paid by all. Gradually extending the number of house connections, and thus the level of service to the community, will often have a positive influence on the financial viability of the system.

A water supply system has to fit into the community's social pattern, and therefore various socio-cultural factors, which often have a profound influence on the use of water have to be taken into account in the planning and design.

It is important that planners attempt to understand the users' point of view, their water needs, practices and preferences, and the community's social and organizational structure. These factors influence both the technical and organizational side of the design of a public standpost system.

Organization and management are essential elements of a water supply. The responsibility is often divided: planning and construction fall under a government department, while a local authority is responsible for operation and maintenance. The alternative is to have both planning and management governed by a unitary water authority, that also has a high degree of autonomy regarding finance. This agency should be responsible to the government and has to coordinate its activities with local and municipal authorities. A legal framework is always required to define the rights and responsibilities of the water authorities, the local committees and other agencies involved in the organization and management of the water supply system.

Operational management includes operation, maintenance, supervision, revenue collection, and liaison with the users.

It is important that maintenance organization includes regular inspection and preventive maintenance as well as repairs after breakdowns. Supervision is necessary where water is scarce, where there is a risk of vandalism and where water has to be paid for on the spot. Revenue collection, whether periodical, or per volume should be acceptable to the community. Open communication between the water agency and the community is of great importance in the planning, implementation and operation stage.

In general, there is a lack of trained technical and managerial personnel. The importance of the latter category is stressed. Training schemes should be set up for the whole range of skilled personnel required.

Organization and management should incorporate a strong element of community participation. Coordination of activities at local level and a continued dialogue with the population are essential. Depending on the extent of community participation and the local organizational pattern, strengthening of the formal community organization may be required.

The standpost itself is the interface between technology and human activities; it is the place where the hand of the user touches the hardware of the system. Therefore, in designing a public standpost, due attention has to be given to the habits and preferences of the users regarding fetching and use of water

Reasonable access to a standpost could be defined as a walking distance of less than 200 metres; in rural situations distances up to 500 metres may sometimes be acceptable. The number of persons served by any one standpost should preferably not exceed 250 and the number of users per tap should be in the range of 25 - 125.

The volume of water drawn daily from a public standpost is in the range of 20-60 litres per capita. The actual consumption depends not only on local habits concerning domestic water use, but also on the availability of other sources.

In many situations, a design period of 15-20 years would be suitable. The initial design should preferably make allowance for future upgrading of the system through the installation of more and more house connections.

Efficient drainage is essential. The simplest form is a soak-away drain under the tap, or next to the platform. Another possibility is a drainage channel to the platform leading to a discharge pipe. A further consideration might be to use the drainage water for cattle watering, irrigation or fish farming.

Wastage of water is often reported as one of the major problems of public standposts. However, measuring of wastage is difficult and when high figures are reported it may be assumed that these also include the leakage in the pipe network.

Some spillage is normal when buckets and cans are filled. The tap is often left open between fillings of two buckets. In some cases wastage is caused by carelessness on the part of the user, or by vandalism. The solution to the problem may lie in the improvement of public information and community organization, rather than in the installation of a sophisticated anti-waste tap.

Experiments and calculations have shown that the cost of a distribution system is affected much more by pipe lengths than by pipe diameters or the number of standposts. Therefore, the pipe network should be as short as possible. Frequently, this will result in branched networks. Provision for some extra capacity through the choice of wider pipes and the installation of extra standposts is usually a good investment.

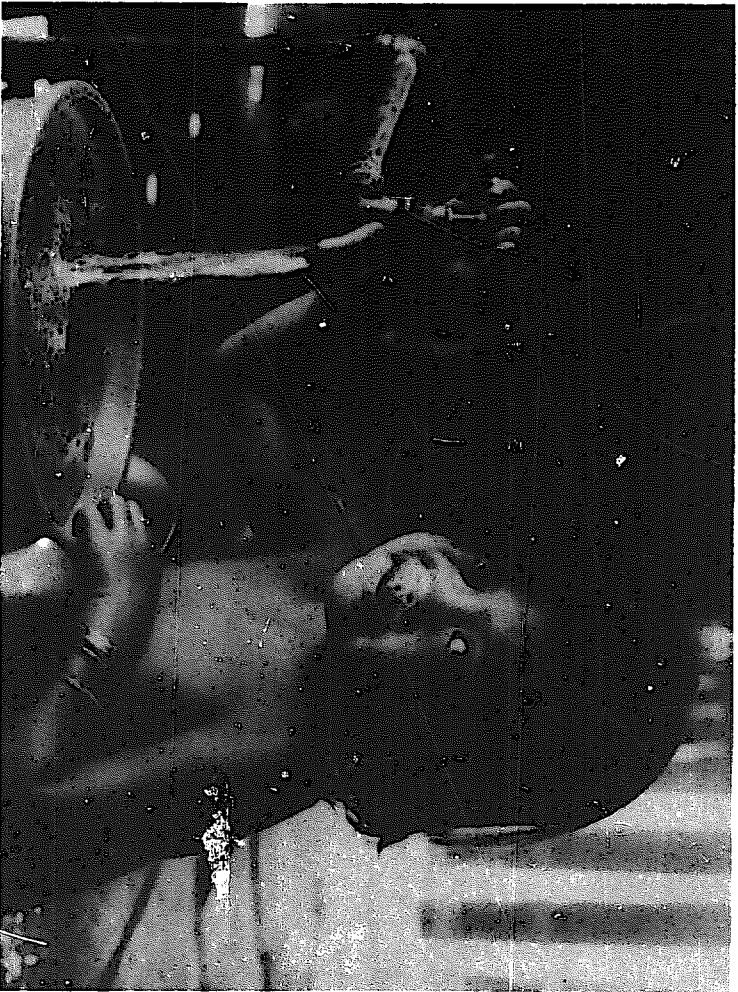

I INTRODUCTION

A public standpost is a suitably supported water pipe, connected with a water distribution system and terminating in a tap or faucet, which is located at a public site, and from which water may be drawn for domestic and other uses. In other publications these installations are also referred to as: public standpipes, public hydrants, public fountains, public taps, public spigots or communal water points.

Many water supply agencies in urban areas regard public standposts as only an intermediate step in the development of a fully house-connected water supply. This policy arises partly from an awareness that the impact of water on health is much improved if people have at least one tap in their own homes; the water will then be used more freely and its quality better safeguarded. Another consideration is that payments for water are much easier to collect from people with household connections than from standpost users, consequently the former usually brings in more revenue.

However, for many people in many countries a public standpost could well be the only feasible method of water supply for a very long time to come. This is especially true in rural areas where scattered housing makes individual connections particularly expensive because of the long runs of pipe required. It is also likely to be the case in low-income urban fringe areas which yield little revenue in return for public services.

The *difficulties experienced in operating standposts* often arise from the way water supplies are managed, from inadequate technical design and from a shortage of resources. There are also problems relating to the institutional and organizational structure, particularly where several organizations are involved in water supply, and the boundaries defining their separate areas of responsibility are not clear. When this happens, some tasks may be duplicated and others entirely neglected. Public standposts also suffer from some of the same disadvantages as other public or communal services.

Most of the difficulties are caused by a combination of factors. Therefore, in solving the problems it is necessary to consider the situation as a whole. This may be illustrated by referring to the wastage of water at standposts. If taps are left open, it may simply be because users are careless, but it may also happen because the taps are difficult to turn, due to poor design or poor maintenance, or because the water supply is intermittent and when no water emerges from the tap, the users forget that it is open. Thus a solution to the problem of water wastage may depend on improvements in the technical design, or in management (e.g. improved maintenance), or in user education and local organization. In all probability, several of these improvements will need to be made simultaneously.

The key point to note here is that a public standpost, like any other water supply installation, is not simply an isolated piece of technical equipment, but is part of a system in which there is also a large component of organization and management. It is only by taking an integral view of the whole of this system that we can understand how to operate it successfully.

Therefore, integral planning of all relevant factors is of crucial importance. From the technical point of view, installing a standpost presents no major difficulties. The problem is how to ensure for continued and proper use and maintenance, and for regular payments of water charges. The best chance of achieving these ends lies in *a careful consideration of all relevant aspects and their inter-relationships during the planning stage* (annex 1).

Against this background, various institutional, organizational, economic, financial, administrative, socio-cultural and technological aspects are discussed in the following chapters.

The institutional aspects include the relationships between central government departments, local and municipal authorities and community organizations. The organizational part comprises the function of the local waterworks staff and the work they do in operating and maintaining the standposts, as well as community participation in this work.

Users interact, formally as well as informally, with the institutional structure and the operational management through community water committees, standpost caretakers, revenue collection, maintenance arrangements, and the day-to-day use of the standpost.

Technological aspects interact with organizational and social aspects in many ways and good technical design of the standposts is of no avail, if the result is not compatible with the organizational and social structure. Therefore, special attention has to be given to the *various inter-relationships* which exist between the technological, organizational, economic and social aspects.

The technical "hardware" part of a public standpost water supply system comprises "upstream components", such as, the catchment, reservoir, treatment works and distribution pipes; and "downstream components", concerned with drainage and the disposal of water after use. The system is likely to serve some individual houses as well as standposts.

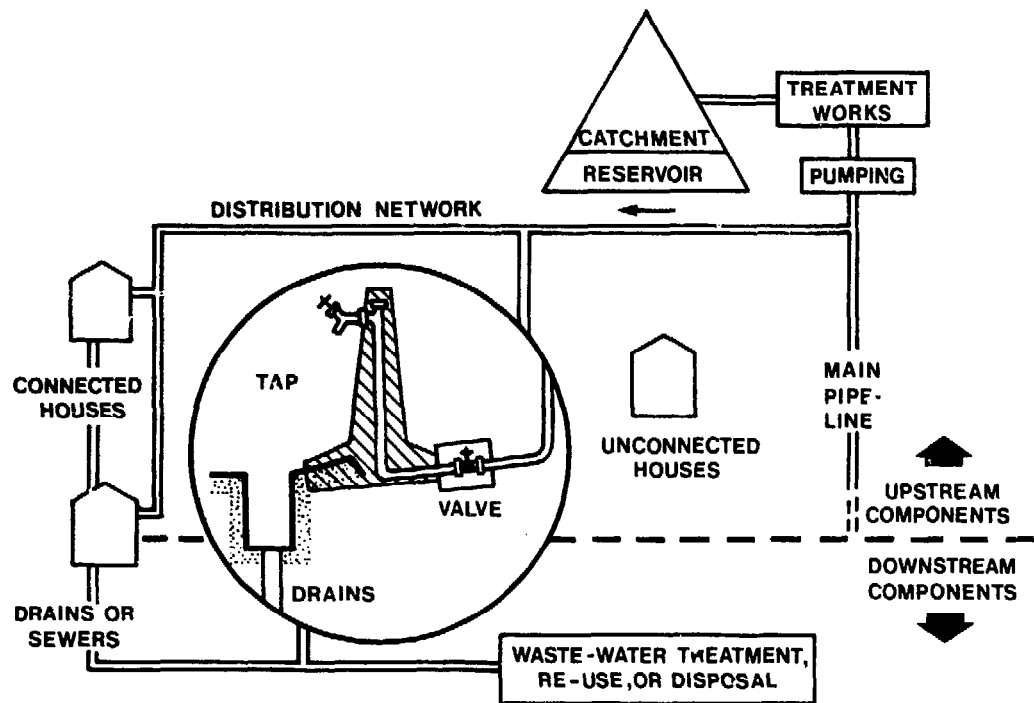

FIGURE 1: COMPONENTS OF STANDPOST WATER SUPPLY SYSTEM

Much of the engineering is likely to be based on standard practice for any type of piped water supply. These standard details are not discussed here, since the scope of this publication is limited to items directly related to public standposts

This publication is mainly directed to features peculiar to public standposts, such as:

- (a) the service pipe with its valve, connecting the standposts to the main pipeline;
- (b) the tap (faucet) or other water flow control mechanism;
- (c) the structure supporting the tap, and the base unit;
- (d) drainage of waste water from the standpost area.

In most respects, the service pipe, and indeed the network of supply pipes to which it is connected, need be no different from the pipes used in the system with house-connections. However, the choice of pipe diameters, and therefore supply capacity, greatly influences the economics of a standpost system.

It is evident that in particular the taps and the standpost-platform are of great importance to the whole system, because they represent the principal meeting place or *interface between technology and human activities*. This is the point where users make contact with the hardware, and where operational management must focus much of its efforts on maintenance and public information.

A water supply system is not an end in itself. It usually forms part of a broader programme of rural development, of slum upgrading, or of primary health care. This means that, in addition to the various aspects of the water supply programme itself, the activities in other sectors have to be taken into account as well. Coordination of the water programme with community development, health education, or irrigation and fish-farming projects, to name a few examples, will greatly enhance the benefits of all development activities.

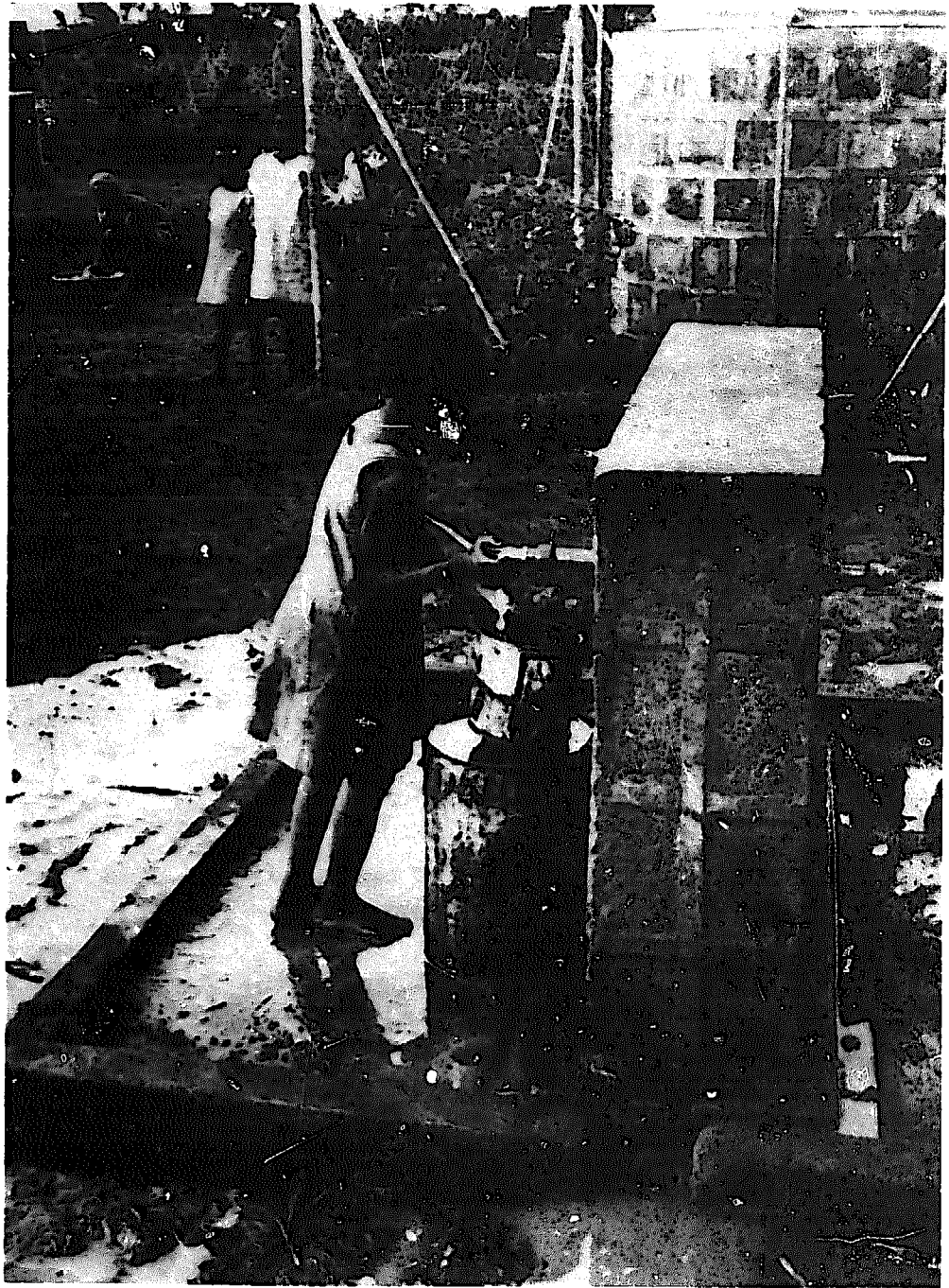

*PUBLIC STANDPOST AND TAP AS INTERFACE BETWEEN USER
AND TECHNICAL SYSTEM*

II ECONOMICS AND FINANCE

GENERAL CONSIDERATIONS

Economic analysis can make an important contribution to the planning of public standpost water supplies in at least three ways. Firstly, before detailed design begins, study of the likely costs in relation to the number of people benefiting can help planners decide on the appropriate level of service. Then, once the service level has been fixed, further examination of capital and recurrent costs can assist in arriving at an optimal design. Finally, economic considerations must be brought to bear when tariff structures and rates are set.

The major benefits from standpost supplies, as compared to drawing water from a stream or open well, are better health, greater convenience and a saving of time. Intuitively, one expects that as the number of distribution points increases, so will the benefits. However, piped water from standposts can become contaminated at the standpost, or when being carried to the dwelling, or inside the dwelling (where it is not likely to be consumed immediately). The longer water is left outside the distribution system, the higher is the risk of contamination. For these reasons, it is not probable that public standpost systems will provide a high level of health benefits. To achieve the full health impact, public standposts will need to be replaced when financially feasible by a system with house connections. While funds remain limited however, standposts may represent the optimal solution.

Since many water-related diseases do not spread only through water but also through infected food and unsanitary living conditions, it is exceedingly difficult to isolate and quantify

the beneficial impact upon health of improved water supply only. Numerous studies bear witness to these difficulties. Even if it were possible to identify exactly what improvement in a community's state of health is due to a better water supply, the next step of putting a monetary value to this improved state of health faces insurmountable difficulties. Therefore, cost/benefit analysis of this type need not and should not be attempted.

Several studies have also demonstrated the crucial role of health education. Health benefits are best achieved when the population is instructed how to draw the water, how to transport it, and how to store it, and when they appreciate the value of more frequent washing. Therefore, public standpost water supplies should never be provided without a substantial educational effort. However, education does not come free, and there is an economic trade-off between the physical distribution facilities and the education campaign.

The planner's view of the economics of a standpost water supply will be strongly influenced by the quality and extent of the service he can provide within the available budget. Decisions about the most appropriate mix between house connections and standposts may be based upon cost-effectiveness considerations, as may decisions about the most appropriate level of water treatment. However, there are considerable problems in doing this. The total costs of the system must first be estimated - they comprise the sum of the capital and the recurrent costs over the system's economic life. Totalling the costs in this way involves assumptions about interest rates, and adjustments to take into account market imperfections, using a process known as "shadow pricing".

Rapid progress in the provision of water supply depends very much on the consumer's willingness and ability to pay for the water. Therefore, if justification for projects cannot be provided on cost/benefit grounds, the alternative may be to give future users the opportunity to show how they value an improved water supply

by paying for the service. Even in relatively poor rural areas "people may prefer to have, and to pay for, a water supply, than to have none at all". (Saunders and Warford, 1976).

COST OF STANDPOST SYSTEMS

A distinction is needed between the *capital investment costs* associated with design and construction, and the *recurrent costs* which cover operation, maintenance, interest payments, redemption, depreciation, and so on.

The capital investment necessary to set up a standpost water supply varies with the size and complexity of the scheme, and with local circumstances. As an indication, total capital costs for standpost systems are in the range US\$ 10 - 30 per person served. These costs may include expenditure on source-works, treatment plant (or connection to an existing plant), pipelines, a storage tank, the distribution network, and of course, the standposts and house connections. It is difficult to generalise about the breakdown of total costs among these components, but often about half is required to pay for the distribution network and standposts.

This means that in general, the cost of the standposts themselves constitute a relatively small amount of the total capital costs. As an indication, a standpost with a concrete support construction, two to four taps and a platform with a drainage facility is likely to cost US\$ 200 - 500. In contrast, a very simple standpost as used in many villages and rural areas costs as little as US\$ 20 - 50. Assuming that at least one standpost is available for 100 - 200 persons, the cost of the standposts will usually be in the range of 10-30% of the total costs. In comparison, about 30-40% of the total capital costs is normally invested in the pipe system. Careful design of the distribution network can save considerable sums.

The cost of pipes in a water distribution network depends on their length and diameter. The most commonly used equation for expressing the relationship between these factors, reads:

$$C = B_0 \cdot L \cdot D^{B_1}$$

in which C = costs, L = Length, and B_0 and B_1 are positive constants. B_1 usually has a value between 1 and 2 with 1.4 being typical, regardless of pipe materials, country, size of project, etc. The value B_0 depends on the units of C, L and D as well as on construction conditions, pipe material, pipe size and so on. With C in US\$ in 1978 prices, L in m, D in mm, pipe materials of PVC or asbestos cement (AC), and pipe sizes less than 150 mm, the value of B_0 is usually between 0.01 and 0.2 with 0.03 being typical. If for example $B_0 = 0.03$ and $B_1 = 1.4$, then 100 mm diameter pipe (supplied and installed) would cost about US\$ 19 per m; 50 mm and 150 mm pipe would cost about US\$ 7 and US\$ 33 per m, respectively.

In a recent study commissioned by the World Bank, the length and average diameter of pipe in public standpost networks were examined in relation to several engineering design variables (Lauria, ed). The study revealed that the cost of a distribution network primarily varies with pipe length. Pipe length per person is essentially constant for a given population density and number of persons per standpost. For example, with 100 persons/ha and 50 persons/standpost required pipe length is about 1 m/person. Where population density is higher and/or the number of persons per standpost is greater, the length per person is less. The pipe diameter is quite insensitive to these design parameters; average pipe size of about 50 mm to 75 mm is adequate for most systems.

The main variable, then, that affects cost is length, and this depends upon population density and the average number of persons per standpost. Population density cannot be modified but the number of persons per standpost is a variable under the planner's control.

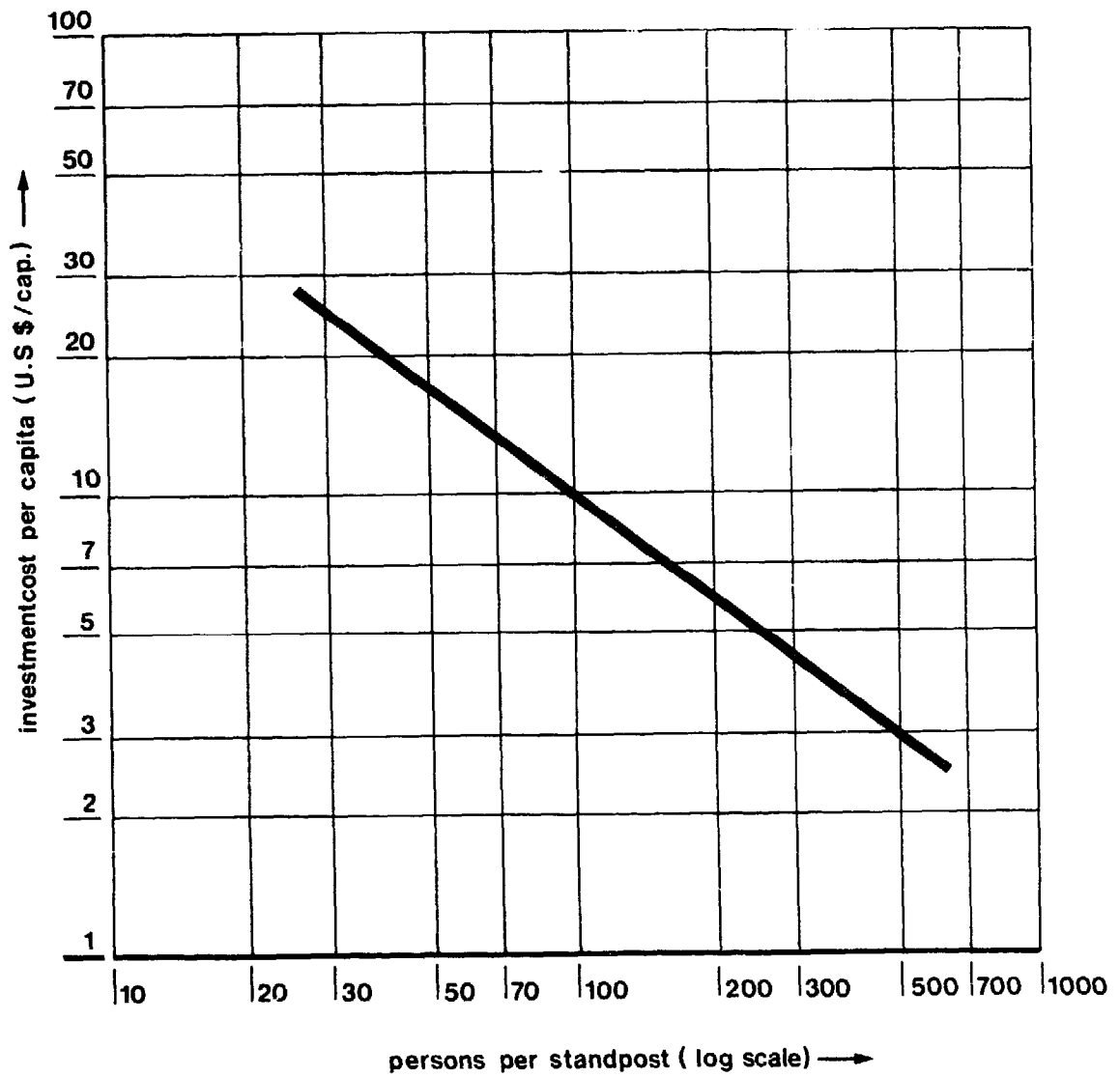

FIGURE 3: INDICATION OF NETWORK PLUS STANDPOST COST PER CAPITA
 VERSUS PERSONS PER STANDPOST
 (for given density = 200 persons/ha).

For an assumed density of, 200 persons/ha the variation in per capita cost with a number of persons per standpost (i.e., standpost spacing) is shown in Fig. 3. (This diagram assumes average pipe costs of US\$ 10 per metre, and takes the cost of one standpost as US\$ 500).

An application of Fig. 3 would be when one knows the number of people to be served and the investment funds available and needs to determine the number of persons per standpost. For instance, with 20 000 persons to be served within a given area with 200/ha density and with US\$ 200 000 available, the maximum per capita investment cost is US\$ 10. It follows from the graph that the number of persons per standpipe is 100 and the number of standposts should be about 200.

SELECTION OF DESIGN STANDARDS

In any standpost system, the major design variables include the number and spacing of standposts, the volume of water supplies per person, the minimum pressure to be maintained in the pipes, the amount of looping to be provided in the network and the minimum allowable pipe size. The principles used in selecting standards for these variables are essentially the same as those required in any standard-setting process: it is necessary to determine how costs and benefits change as the variable is assigned higher values.

However, because of the formidable difficulties in quantifying benefits, direct application of cost/benefit theory is impracticable. As an alternative, it is possible to determine the marginal costs of assigning increasingly higher values to the design variables, judgement can be used to decide whether they are justified by the increase in benefits.

Consider the design variable "volume of water supplied per person". A small increase in pipe size enables the network to deliver significantly larger flows. It appears then, that designers are entirely justified in choosing pipe sizes to allow for a relatively large consumption of water especially when anticipating future house connections.

The "minimum pressure" in the pipe network is another variable for which marginal costs are relatively small. An increase in this pressure can be arranged either by maintaining greater pressure at the source of supply, or by using larger diameter pipes (which will result in smaller pressure gradients). One or both of these modifications introduced at the design stage will add only slightly to the cost of construction. But since low service pressures can be a serious disadvantage through inconvenience to users and risks of contamination, an increase in minimum pressure can lead to quite large marginal benefits. This implies that designers should not hesitate to specify a 10-metre head of water (or more) as the minimum network pressure.

The spacing or number of standposts is a more difficult variable for which to set a standard. It has already been shown that the number of standposts significantly affects pipe length, which is a major determinant of cost. In addition, the cost of standposts themselves is significant. Thus, the marginal costs of increasing the number of standposts is relatively large. The benefits of closer standpost spacing are chiefly due to increased convenience. Health benefits probably remain small until water is actually piped into the house. It does not seem unreasonable to assume, however, that net benefits increase steadily with closer spacing, in which case the maximum number of standposts should be provided within available financing. A target of about 100 persons per standpost is frequently assumed, which appears to be a good starting point from which to investigate other numbers of users per standpost.

The amount of looping to be provided in the network is another design variable for which selection of a standard is difficult. Standpost networks can almost always be designed as branched systems in which case pipe length and cost is minimized. The advantage of loops is that system reliability is improved particularly in relation to breaks in pipes. The marginal cost of this improved reliability, however, is fairly high. The benefits due to closer standpost spacing probably outweigh those due to increased reliability in most cases, which implies that expenditure might better be used to reduce water-carrying distances than in providing extra looping.

Another variable for which a standard is needed is minimum pipe size. As suggested earlier in this Chapter, 50 mm diameter pipe has been found suitable for most standpost networks. Studies by the World Bank have shown that by specifying 50 mm as a minimum size, the increase in network construction cost for an optimally designed system will be in the order of about 15%.

FINANCING

The financing of public standpost water supplies must be assured before construction begins. Most obviously, sufficient and reliable funding must be available to cover capital expenditure. However, it is equally important that there should also be reliable funding for recurrent expenditure on operation and maintenance. The result is that systems break down and remain out-of-order for lack of money to purchase spare parts. This disastrous outcome usually negates such benefits as the standposts initially provided.

When it comes to financing the construction of public standpost supplies, four potential sources of funds may be considered.

- a. contributions from the community to be served; prior to and during construction;

- b. financing generated by existing water supplies (revolving funds);
- c. domestic or external borrowings that will have to be repaid at specified interest rates;
- d. domestic or external grant financing.

It is mainly in rural water supply programmes with community motivation that contributions from the future beneficiaries to the construction cost are likely. Such contributions may be in the form of cash or in kind. They may be levied before and during construction. But the community should also prepare itself for subsequent charges to cover at least operation and maintenance expenditures. In urban slums, community participation is more difficult to achieve. However, it would be well to attempt some participation among the urban poor living in shanty-towns. Necessarily, community contributions will have to be provided by simple socio-economic studies that determine income levels and in effect constitute the first promotional step. Before any construction is initiated, a contract should be drawn up between the community and the executing water authority stipulating the responsibilities of each parts. It is at this stage that the community can be asked to contribute.

Where loans have been raised to finance standposts, tariffs need to be set at a sufficient level to repay them. Alternatively, the loans can be serviced out of general tax revenue, which effectively means subsidizing the water supply. Whichever way the debt is served, lenders have to be informed about the viability of the project. A clear charging policy becomes necessary, including a sound tariff structure and an appropriate method for revenue collection. A socio-economic study will often be required to demonstrate the consumers' ability and willingness to repay the investment cost, and to pay for the ensuing operation and maintenance costs.

Grant financing is still the most common way of paying for water programmes, which may account for the shortages of funds for water supplies experienced in many countries. It is important that grants be reserved for those truly in need. All too often, grants become an excuse for not charging for water at all. The inevitable result is a deteriorating service. What is more, the largest benefits of subsidized supplies go to those who use the most water, and they are not usually the poorest people.

In practice, a combination of grants and loans is frequently used to fund water programmes. In Brazil, for instance, the overall financial objective of the state water companies is that half their capital investments should be self-financed through bank loans which are ultimately repaid. The other half of their investment funds is contributed by the state governments and amount to roughly 5% of tax revenues. In order to repay the loans, the water companies must make as realistic a charge for water as possible, within the ability of the public to pay.

Water supply cannot be considered a free service. Where water is supplied to a community free of charge, this means only that the direct burden of its cost has been shifted away from the consumer. From the point of view of efficiency, there is no doubt that a system of water charges to the user is desirable. It is possible, however, that the pursuit of certain social and other objectives may have higher priority than efficiency criteria.

In many countries, the idea that water supplies should be self-financing conflicts with the view that a water supply is a social service which should be made available to everybody, regardless of the ability to pay. A possible compromise is that the principle of users paying for water is clearly established, but that certain types of supply are subsidized as a service to low-income groups. This means that users of subsidized supplies still pay for the water, but at a rate within their means. Alternatively, one can also reconcile the various objectives by providing a certain quantity of water free of charge or at a reduced price and everything above that quantity at the full price.

The cost of water per unit of volume is determined by the capital costs and the operation costs of the system. The recurrent annual capital costs include interest, redemption and depreciation charges and may easily amount to 15-20% of the total original investment costs. In addition to this to this, there will be operation and maintenance charges, which may easily amount to 5% of the investment costs, per year

For example, a system supplying water to 1000 people through standposts and costing US\$ 15 000, would incur annual costs of about US\$ 3000. Assuming an average use of 30 litres per capita per day (lcd), the unit cost of water is: $3000 \times 1000 / (30\ 000 \times 365) =$ US\$ 0.27 per cubic metre (1000 litres).

When similar calculations are carried out for a house connected water supply, with average consumption amounting to 80 lcd, the unit cost of water is often much less. The extra water drawn from a house connected supply more than compensates for the extra capital costs, so that the water is relatively cheaper.

Public water supply systems often comprise house connections for commercial clients and wealthier users and standposts for the rest of the population. It is then possible to introduce tariff structures that charge more than the cost of supply to higher volume consumers and use the surplus to subsidize lower income consumers relying on public standposts. Such "cross-subsidies" can make systems financially self-sufficient, provided that industrial, commercial and wealthier domestic clients can compensate for the large numbers of the poor. As a matter of fact, whenever charges to users are allowed to fall below the costs of supply, the difference has to be covered either from outside through concessionary financing or through cross-subsidies. In order to determine the extent to which cross-subsidies may be used, it is necessary to consider the alternative supplies available to wealthier consumers. If discriminatory tariffs are allowed

to deviate too much from the costs of supply, industrial, or other large consumers may opt to construct their own supplies and the opportunities for cross-subsidies are lost. A socio-economic study will help indicate a realistic tariff structure.

In general, user charges constitute a reliable way of defraying operations and maintenance expenditures; even the poorest communities should be able to cover these current costs. In rural areas, communities can manage their own payment systems with proper support from the central water authority. In urban systems, efforts should be made to simplify collections to avoid a situation where the cost of charging for services exceeds the revenue collected. Charges should preferably be flat rate, monthly, quarterly or the like. They can be based on the number of dwellings within the standpost area, or upon the number of persons or households living within a certain distance from the standpost. They may also be included in the house rent. Charging something for the supply is also likely to educate the population concerning the value of water and its cost, which will pave the way for house connections.

A primary condition for appropriate methods of revenue collection is that people recognize the charges as legitimate. Therefore, they should be made fully aware of the expenses involved in operation and maintenance so that they understand that a charge is necessary to cover these costs. This requires adequate public information and education.

Metering public standposts may be useful where water is provided to a well defined group of people who can be charged according to the meter reading per fixed period of time. This applies for instance to a school or a health centre or a cluster of families that are willing to accept a collective responsibility. However, metering and billing each consumer individually is neither feasible nor desirable. In practice, this system would require the presence of a guard whenever the standpost is open to the community, which raises the cost of supply considerably and adds to the administrative

burden. On top of that, wherever there is a "middleman" involved in the distribution of water, whether he be a vendor, guard, or concessionaire who operates the standpost, users are likely to find themselves paying exorbitant prices per unit volume of water.

The reduction of wastage and spillage, sometimes quoted as one of the advantages of metering a supply, can in general be better achieved by education of the users and/or social control in the case of a collective responsibility. Thus the case against metering public standpost water supplies is very strong and only in exceptional cases is it justified. Metering for the purpose of studying the consumption pattern is such an exception.

How the revenue from consumers' payments is used depends upon the institutional structure. Where there are unitary water authorities, revenue can be applied directly to the costs of water supply. Problems arise, however, when responsibility for water supplies is divided between local municipal councils and a government department. If the water charges are levied by a local council, they may be regarded as just another form of local taxation, and there may be no real effort to use the water charges for financing the operation or the development of the water supply. Thus, the water system may be deprived of the revenue it generates and may, as a result, be badly maintained or inefficiently operated, while its revenues are diverted to other local services such as roads or housing. In these circumstances, unitary water authorities have a definite advantage as discussed at greater length in Chapter IV. on Organization and Management.

Socio-economic studies that determine cash income levels may also help indicate how much finance will become necessary to transform the standpost system into one with more connections. Typically, low-income families do not have savings to pay in cash for connection fees that can amount to several months' salaries. To encourage the spread of house connections, credit should be extended

over a long period. It may be better to levy only a nominal connection fee and thereafter recuperate the cost of the connection as part of the water consumption charge over, say, five years. Such a system will require metered house connections with progressive water rates, increasing rapidly with the amount consumed.

In order to facilitate further the spread of house connections, those connected should be encouraged to sell water to their unconnected neighbours with the only conditions that the selling price of water should be clearly posted. This will have the same effect as a denser provision of standposts. There is no need to license sales from individual house connections as is sometimes practised. The desire should only be to dispense as large quantities of water as possible, provided that the water is paid for and provided that the water authority has an opportunity to monitor and compare prices charged at these communal water points.



WATER VENDOR

III SOCIAL ASPECTS

SOCIAL APPROPRIATENESS

An obvious point, frequently stressed nowadays, is that technology should be "appropriate" to the conditions in which it is used. It is desirable that public standposts should be so well adapted to local conditions that they can be regarded as an "appropriate technology" in this sense. The economic issues discussed in the previous chapter show that standposts are economically appropriate in certain places but not in others - they are *economically appropriate* mainly where investment funds are severely restricted and in rural areas where house-connected piped water is excessively costly.

Next to this, it is important to ensure that a water supply system is *socially appropriate*. To achieve this, planners need to know a good deal about the community which the standposts will serve. They will need to know, for example, whether standposts will be acceptable to the local people, and whether the servicing and maintenance requirements are compatible with local skills and organization.

A standpost water supply is only likely to be socially appropriate, consonant with its surroundings and adapted to the users' needs if those who plan and build it have a clear view of its purpose. So when a new water supply is to be constructed, the first step in the design process should be to define the planning objectives, and to decide what kinds of benefit the supply is intended to confer.

PLANNING AND SOCIAL ACCEPTABILITY

The immediate objective of a standpost water supply is usually *to give as many people as possible the benefit of a "safe" water source at a cost which the community can afford.* Further goals may include the upgrading of the water supply at a later date; they will also certainly include long-term objectives concerning improved health and standards of living - goals which may not be defined with much precision in the planner's brief, but which are the ultimate reason for investing in water supply.

In evaluating water supply's appropriateness for the community it is intended to serve, there are key questions to be asked about the planning objectives. They are: first, is the water supply relevant to the felt needs and expressed wishes of the people who use it? Second, are there any conflicts between the objectives of the system's planners and the goal of its users?

It has to be recognized that planning objectives, however benevolently framed, may seriously conflict with what the local people want and need. It is therefore important that planner attempt to understand the users' point of view, perhaps by holding public meetings or discussions with the community leaders, and possibly by social surveys of water use practices and preferences. In this phase of the work planners and community workers need to work closely together.

Consultation of the local population should be carried through with conviction, so that the people take part actively in the planning process. This is a practical necessity if in the end the water supply is to meet their demands satisfactorily.

Besides listening to what people say, planners should take note of local habits regarding laundry, personal hygiene, bathing babies, washing pots and watering gardens. If people are in the habit of doing their laundry at the water sources, then standposts which do not provide for this may be misused. In part of India the bathing of children under standpost taps is common. Such activities may lead to taps becoming contaminated and to water being wasted. However, if local custom is that laundry and personal hygiene are tasks carried out at the water source, the community may feel that a standpost which does not cater for such activities is seriously inadequate. Thus planners should consider what other facilities are available for laundry and washing, and should perhaps ask whether a shower or wash-room and a laundry slab might be provided near by the standpost. The point here is that the public standpost must offer a definite advantage in the facilities provided if it is to be fully appreciated and properly used by the community.

Where conflicts arise between the views of planners and those of the local community, this is most often because basic questions about cost and convenience to users have been overlooked by the planners. For local people, the "cost" of water is likely to have three components - the money to pay for use of the standpost; the time they spend carrying water to their homes; and the effort they devote to local organization, construction and maintenance work.

The distance water has to be carried from the standpost may be the most crucial factor. If people have to pay in cash to use the standpost, the advantages in terms of reduced carrying distance must be sufficient for the cost to seem worthwhile. For most users, the health benefits gained by using safer water will seem intangible and remote compared with the benefits of a more convenient supply.

It is important to bear in mind that communities are rarely homogeneous: different interests exist within them. In any community there is a range of incomes among individual households. The amount which people are willing or able to pay for water varies, whereas charges for the use of standposts cannot usually be so flexible. Unless standpost supplies are provided free through a subsidy from sources outside the community, there is a potential conflict of interest between better-off and poorer sections of the community.

The precise nature of the need for water in a particular community depends on the way in which people use the water. In some communities, for example, large volumes of water will be needed to meet the basic requirements for effective food hygiene, because *local customs* in preparing and serving meals entail the use of much water in cooking and the washing of many pots. In another community, however, where meals are more simply prepared the water needed for effective food hygiene may be much less. The same applies for personal hygiene. Thus, the quantity of water required for washing, bathing and cleaning vary considerably, depending on climate, personal habits, religion and status.

The way in which *the carrying of water* is organized directly affects the design of standposts. In most parts of the world, it is the women who fetch the water needed in the household, but in some places the children take over part of their task. Where this custom prevails, it may be necessary to construct public standposts with taps at two different heights. If women carry water on their heads, they usually prefer a standpost with small platforms or stands about 1,0 m above the ground, where the buckets can be placed for filling. The tap may then need to be 1,6 m above the ground. This would be out of the reach of many children, for whom taps at a height of about 1,1 m should be provided.

This is an instance where people's *needs* regarding facilities at the standpost are determined by the way in which they *organize* the carrying of water. If both ox-carrying and head-carrying of water are to continue after the installation of standposts, the standpost design should allow for the different sizes of container in use (annex 2).



SOME PUBLIC HYDRANTS SERVE TOO MANY PEOPLE



A WATER CARRIER WITH YOKE

The layout may have to provide for the bathing of young children at the standpost, or for the washing of laundry. It may be a good idea to observe existing practice at traditional water sources in order to make sure that the standpost offers at least the same facilities as the old supply.

Some needs might not be immediately apparent. The need for women to bath in privacy may be met at the existing water source simply by virtue of its relative seclusion. In the more frequented location of the standpost it may be necessary to provide an enclosed bathroom. Some other solution may be preferred by the users and in this case, of course, it would be essential to consult the women. Women may also value the opportunity for social contacts while fetching the water.

It may seem inconvenient to have to provide for some of these secondary needs. The bathing of children at the standpost may use - some would say "waste" - a considerable amount of water. But it may be less costly in the long run to anticipate and cater for such needs than to take measures to counter "misuse" of a system more narrowly designed. The expensive alternatives may be the employment of guards or the risk of damage resulting either from attempts to adapt the system to the use desired or from vandalism.

If a planner is influenced by prejudices or if he adopts a patronising attitude to people in poorer groups, this can be far more damaging to the success of his projects than any of the cultural beliefs held by the users. Where sanitary facilities are misused, the task of the planner is not to judge the people, but to try and overcome any practical problems the users may have with the system and to provide additional information on the advantages of proper use of the facilities.

Among the cultural factors which may influence users' attitudes towards a water supply, the most important arise in some religions - from associations of water with moral purity and cleanliness. Concepts of ritual cleanliness may influence people's washing routines and affect their views on the choice of a site for the standpost, and on whether it should be exposed to public view or placed inside some sort of enclosure.

However, one should not over-emphasize the negative influence of local culture. For most persons, *the practical convenience of the standpost* is far more important and in many cases, cultural habits play a constructive part in support of local water supply programmes.



THE STANDPOST AS A MEETING PLACE

SOCIAL ORGANIZATION

Communities have both *formal* and *informal* kinds of social organization associated with the use of water. The question of how water carrying is organized is an informal family matter, but access to water sources may be organized in a more formal way.

Many of the details of water use are likely to be covered by informal modes of organization. Questions of where laundry is done and where and when people wash themselves are likely to be the subject of quite definite but informal patterns of organization and behaviour. Informal organization may also include arrangements between families to share some tasks, while the inception of a new standpost scheme may impose new tasks which have to be shared, like cleaning the standpost, or stopping children from playing with the taps.

The informal sector is also important for the social acceptability of new water supplies. If the introduction of a standpost tends to disrupt social contacts which women enjoy while fetching water, or if it makes it impossible to bathe or wash clothes at the water source in the traditional way, the standpost may be less acceptable on those counts.

Another aspect of informal organization associated with water use is that there may be people who are paid to do various tasks: for instance the water vendors. Such people, who are paid to fetch water for others might be opposed to a standpost scheme, as might people with private wells who sell their water. It has happened that a water supply improvement was sabotaged by a man who made leather buckets and ropes for drawing water from wells, and who felt that his livelihood was threatened.

For a public standpost system to be a "socially appropriate technology" in the sense described at the beginning of this chapter, it is not sufficient merely for it to be socially acceptable in terms of convenience, cost and culture. A standpost may be fully accepted in all these ways by the local community, but it may still fail if its operation requires a degree of organization which does not exist. The planning of a standpost system, therefore, must also include the development of a more formal organization capable of operating and maintaining the system, and this will involve training people in the necessary managerial and technical skills.

Criteria for good organization, such as adequate supervision and maintenance, regular cleaning and disciplined use are strongly linked with technological criteria. If criteria for good organization are fulfilled less expense is necessary in meeting the technological criteria.

The ability to dispense water without contamination, the effectiveness in reducing wastage and spillage, the ability to withstand vandalism, and the durability of the standpost are all aims which may be effectively achieved by a combination of technological and organizational factors.

For example: the prevention of contamination of water requires an appropriate technological design as well as regular cleaning and disciplined use. Another example is the reduction of wastage. This has sometimes been interpreted as a purely technical problem, and much effort has been devoted to designing spring-loaded taps which close automatically as soon as the user ceases to press down on them. However, experience shows that the more sophisticated systems do not, in general, show a definite advantage over the ordinary tap as far as reducing waste is concerned. It has often been found that the standposts with mechanical devices to reduce

the discharge and/or wastage in practice challenge the user to find ways to "modify" the system, in order to make water more easily available. Taking all aspects into account, an acceptable system could well be a hand-operated screw tap of good durability, in combination with effective maintenance and proper operation by the consumer.

Thus criteria of good organization, such as social discipline and supervision, are more relevant to this problem than technological design.

It has been noted that vandalism sometimes occurs at standposts which are not acceptable to the community and which people find frustrating and difficult to use. But vandalism may also occur because of problems within the organizational part of the overall system, such as failure to organize adequate supervision at the standpost. There may be a failure on the part of the parents, or a lack of social discipline throughout the community; or it may be that management does not fulfil its supervisory functions adequately. Where vandalism can be prevented by adequate planning and organization, time and effort should not be devoted to creating a vandal-proof technology.

IV ORGANIZATION AND MANAGEMENT

INSTITUTIONAL STRUCTURE

Good organization and effective management are essential for the success of public standpost water supply systems. When management is poor, the operation of the water supply tends to be irregular and maintenance is neglected - resulting in low water pressure, irregular and unpredictable flow, frequent break-downs and general malfunctioning.

The poor administration that leads to those problems may be the result of many factors, including inadequate training, staff shortages and political pressure. The institutional arrangements within which management staff have to work may also be the cause of some failures. Figure 4 illustrates two alternative institutional arrangements. In the first, found in many countries, responsibility for public standposts is divided between one or more government departments and the local authorities. This arrangement has many disadvantages and has often been blamed for the ineffective maintenance of public standposts, handpumps and other communal facilities.

The main alternative, often regarded as more efficient, is to set up a *unitary water authority* to handle all activities associated with water supplies. Though unitary authorities of this kind are responsible to government and have to coordinate their activities with local authorities, they can have a high degree of autonomy in planning and finance. This set-up sometimes has the disadvantage that it tends to become insensitive to users' needs.

A. DIVIDED RESPONSIBILITIES

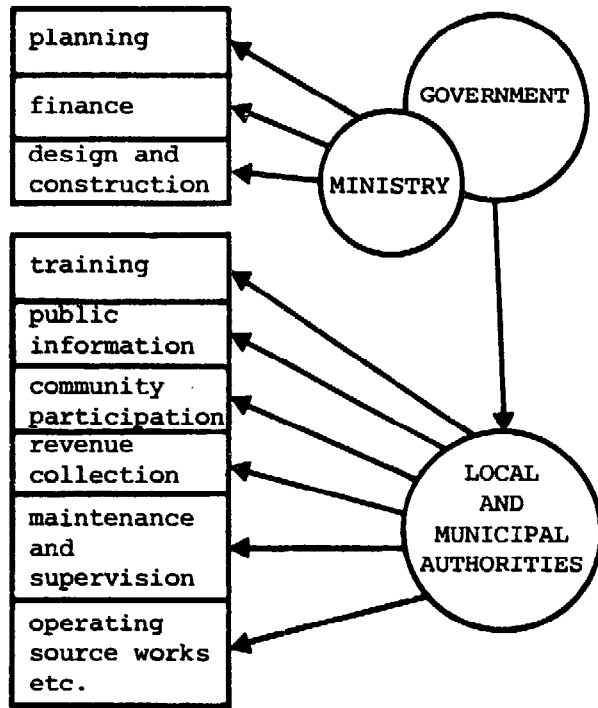

B. UNITARY WATER AUTHORITY

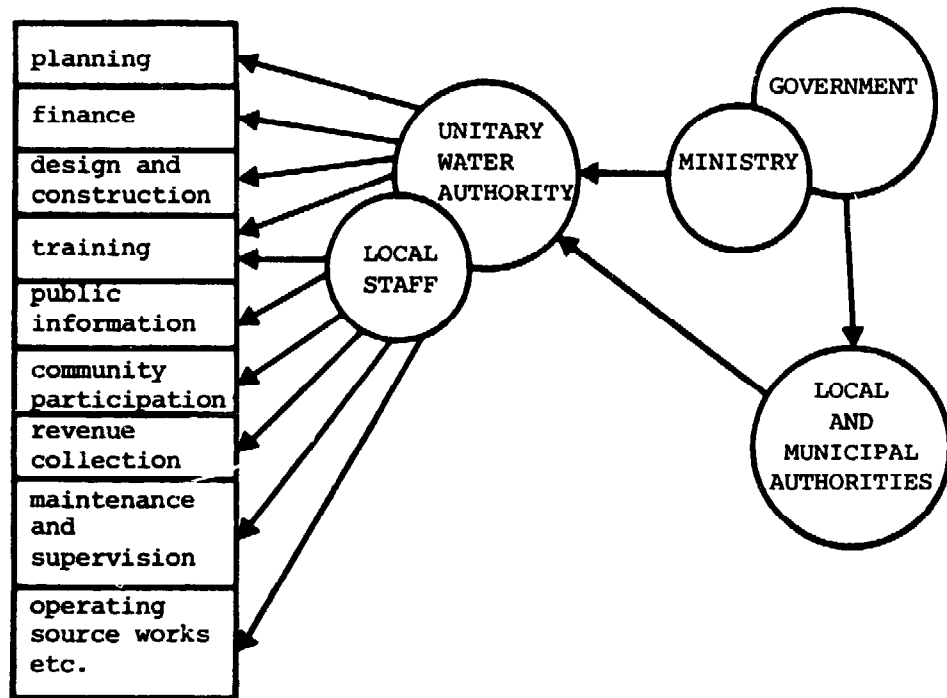

FIGURE 4: TWO ALTERNATIVE INSTITUTIONAL ARRANGEMENTS

Arguments can be raised against either structure, but it is possible to devise modifications of both systems to suit local needs and so avoid potential pitfalls.

In many countries, standposts are constructed by government departments and are then handed over to local or municipal authorities, who are expected to operate and maintain them. These authorities often have very limited resources. They may find it difficult to recruit and retain suitable staff to carry out the necessary maintenance work, as career prospects are limited, service conditions unattractive, and salary scales low. Budget limitations result in poor operation and neglect of maintenance and there is little return on investment. Another disadvantage of this division is that the engineers responsible for construction are not concerned with operation and maintenance. Their design criteria may be drawn up without any reference to the way maintenance will be arranged.

If the responsibility for water supplies is divided among several bodies, steps must be taken to ensure that all essential functions as indicated in figure 4 are properly carried out in coordination with one another. It is noteworthy that where unitary water authorities are set up they almost always deal with waste disposal as well as with water supply, since the two are inextricably linked.

Here is a comprehensive list of the tasks to be undertaken:

- (a) *planning*, i.e. defining populations to be served; identifying particular needs in the local community; determining whether public standposts are an appropriate solution; and phasing construction.
- (b) *establishing a legal framework* for public standposts, especially regarding ownership, and regarding the rights and responsibilities of all organizations involved.

- (c) *design and construction* of standpost water supplies.
- (d) *source works*: construction or modification of source-works: treatment works, pipelines, etc., to supply water to the standposts.
- (e) *finance*: raising grants or loans to pay for construction; fixing water charges to repay loans or to pay operating costs.
- (f) *training* of technicians and management staff, and any members of the local community who undertake responsibilities for maintenance or supervision.
- (g) *community involvement and participation*, consulting local people about planned development, giving public information, and health education.
- (h) *operational management*: supervision of standposts, maintenance and revenue collection.

In reviewing these functions it will be noted that some entail active operations in the immediate vicinity of the standposts, especially community involvement work (g) and operational management (h). These responsibilities might be undertaken by locally-based staff. Other functions, however, can be centralized at the water agency's headquarters.

Another point to note is the importance of item (b) in the list, the establishment of a *legal framework*. The problem here is that standposts are communal or public facilities and are not privately owned. The ownership of the standpost and the land it occupies may thus need some special legal provision, as may the methods used for raising charges from users. It is obvious that the rights and responsibilities of the water authority need to be legally defined, but it may not be so obvious that any local village water committee that is set up also needs a legal basis, even if a very informal one.

Operation and maintenance of a water supply often entails a considerable amount of administrative work, and this is an issue which planners tend to forget during the early design stages. *The importance of designing the organizational aspects of the water supply in parallel with the technological aspects cannot be over-emphasized.*

The planning of a standpost system, therefore, must include the development of an organization capable of operating and maintaining the system, and this will involve training people in the necessary managerial and technical skills.

STAFF REQUIREMENTS AND TRAINING

Shortage of manpower, particularly for supervision and management, is a major factor in the poor performance of many water supplies. The reason for this is that the need for technical training is usually recognized, but the need for training in management skills is often overlooked. But the need is there, often at a very basic level, for standpost caretakers and supervisors as well as for technical staff, and each employee should be given short additional periods of training during his employment with the water supply organization. Planners and designers of standpost systems also require training and in-service refresher courses to up-date them on new thinking and new techniques.

Thus training programmes will need to include management as well as technical skills. A water supply programme is not merely an engineering project, but it involves social, health, financial and management aspects as well. Training and recruitment policies need to recognize that a water programme is a multi-disciplinary effort.

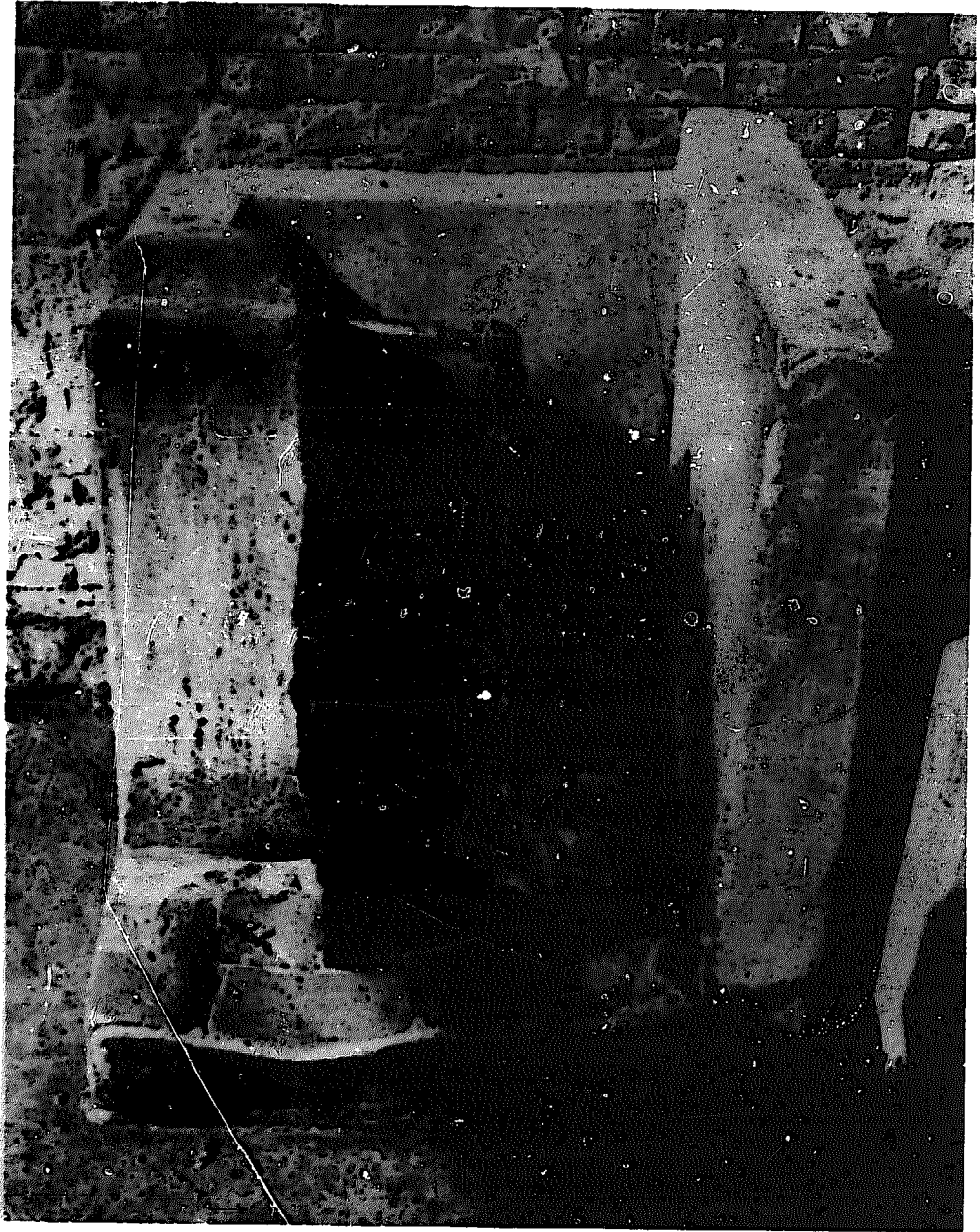

MAINTENANCE : OFTEN A MAJOR PROBLEM

A further point is that, although a water authority may need to initiate a training scheme, its own demands for staff may not be sufficient to support an unassociated training programme. In such cases it may be preferable to set up a scheme to serve all water suppliers in the country, including, for example, the training of plumbers for work in the private sector. The training requirement will have to be considered for the whole range of skilled personnel, such as mechanics for pumps and meters, pipe fitters, bricklayers and administrators. Training for relatively unskilled local caretakers and supervisors may require special provision, e.g. on-the-job training.

OPERATION MANAGEMENT

It is not uncommon that the management of the day-to-day operation and routine maintenance of water supplies is pitifully inadequate. Sometimes through poor maintenance, water supplies are actually failing at a more rapid rate than they are being constructed. To focus attention on this problem and to describe the range of skills and disciplines that are so often lacking, it seems fitting to introduce the term "operation management". This refers to routine management activities, including the organization of maintenance and revenue collection, and is distinct from the level of management which determines general policy and plans the financing of projects.

The immediate objective of a standpost is to supply water. Maintenance and supervision, regular and competent enough to keep the standpost producing water efficiently, must therefore be the first priority for operation management. Another priority must be liaison with users of the standpost on a very basic level,

with means of communication adequate for them to feel that the management staff are responsive to complaints and will carry out repairs when the need for these is reported.

Since it has been stressed that many standpost water supplies today have to be at least partly self-financing, revenue collection is also an important task for operation management.

Where good maintenance and effective lines of communication with users are established, people will feel that they are getting a good service, and may then be reasonably cooperative with management in the matter of revenue-collecting. If, however, the standposts are badly maintained and do not provide a reliable water supply, if the operational staff are arrogant and unresponsive, then there is no point in even trying to collect revenues.

MAINTENANCE

Maintenance is a term which is often used loosely to mean the repair of broken equipment, but here the concept *preventive maintenance* must be introduced to stress the importance of measures aimed at avoiding breakdown. These will normally be very basic activities such as cleaning, tightening bolts, and regularly replacing tap washers. Repair, in contrast, means bringing the standpost back into operation after a breakdown. A maintenance organization should carry out *preventive maintenance* as well as doing repairs. In practice, however, preventive maintenance is often neglected and "maintenance organizations" become merely repair organizations, sending out repair teams only when standposts are broken or taps leak badly.

The key to good preventive maintenance is *regular inspection* of the standpost and attention to minor symptoms or malfunctioning. A tap that drips slightly when it is closed or which is difficult to operate may become a source of serious trouble if neglected. But if it is repaired promptly, while the symptoms are still barely noticeable, that trouble will be prevented. Taps may need more maintenance than any other part of the standpost, but sometimes it is also necessary to carry out repairs to the platform, the support structure and the attachment of piping to the picket on the wall. If a water meter is present, it should be checked. It is also advisable to clean the platform and the drainage system regularly (annex 3).

To sum up, maintenance programmes need to include the following activities:

- (a) keeping the standpost and surrounding area clean, and making any small adjustments, such as bolt tightening;
- (b) inspection of the standpost once a week by someone with mechanical knowledge and appropriate tools noting and correcting any minor malfunction; observing whether tap washers or other parts need replacement;
- (c) arranging for a person or a team with sufficient equipment to visit every standpost at regular intervals, or as necessary, to carry out major overhauls and repairs;
- (d) procuring and holding in stock the necessary spare parts, and ensuring that they reach the areas of need without delay;
- (e) arranging for all the above activities to be adequately financed (some capital investment will be needed to establish a stock of spare parts in a suitable store where they can be properly supervised).

Given that these are the activities necessary to ensure that public standposts are properly maintained, the question remains how such activities might be organized. Maintenance organization can be classified as "decentralized" if some of the work is delegated to the local level, and as "centralized" if all the activities are carried out by a unitary water authority.

With standposts in rural areas, the decentralized pattern of organization will often be the only realistic option. Alternatives such as cleaning the standpost and periodic inspections to check whether parts need replacing might then be carried out by local persons, who should be given some training as standpost caretakers. Such an arrangement may relieve the central organization of part of the maintenance work and its financial burden, but it will still be necessary for salaried technical staff to visit the standpost occasionally to carry out major overhauls and to give guidance and advice to local caretakers.

In urban areas, centralized organization is more likely to be appropriate. Under this system, day-to-day cleaning and inspection of the standposts is the responsibility of paid supervisors or guards, who may in turn employ labourers for the cleaning work. The guard is a paid employee of the water authority and will liaise directly with the maintenance staff of his organization. This arrangement makes every maintenance activity a direct responsibility of the water authority. Maintenance of urban standposts may, however, be decentralized if licenses or kiosk-holders have an independent status and organize the more basic maintenance activities themselves.

Experience suggests that each public standpost should be inspected about once a week. A trained inspector should be able to check from 25 to 50 standposts every week (in rural and urban areas respectively), and to carry out the routine maintenance. For larger repairs a team consisting of one pipe fitter, one mason and two labourers should be available. Experience will indicate the number of standposts to be covered by this team, though as a rough guide a maintenance supervisor may be responsible for up to 500 standposts, and he could have up to three teams working under him.

Naturally, the amount of maintenance involved, and the resulting costs, depend on the quality and type of construction of the standpost and base unit; the number of people served per standpost; and the quality of the water, especially its corrosive properties. Costs will also depend on the distances to be covered by staff between standposts, and the area served.

One extra task to be added to the duties of the maintenance and inspection staff could be the regular monitoring of water quality. Frequent monitoring, however, is not practicable in many situations, and, in any case, had better be rendered superfluous by maintenance carried out with the specific aim of preventing contamination of the water. This means checking the condition of distribution pipes as well as maintaining the standpost themselves. In badly maintained systems with numerous leaks in the pipelines pressure is often so low that contaminated water from outside the system drains into the pipes and creates serious health risks for consumers.

One feature of maintenance organization which needs more emphasis is that of spare parts. Wherever there may be delays in delivery, the maintenance organization will need to build up a stock of

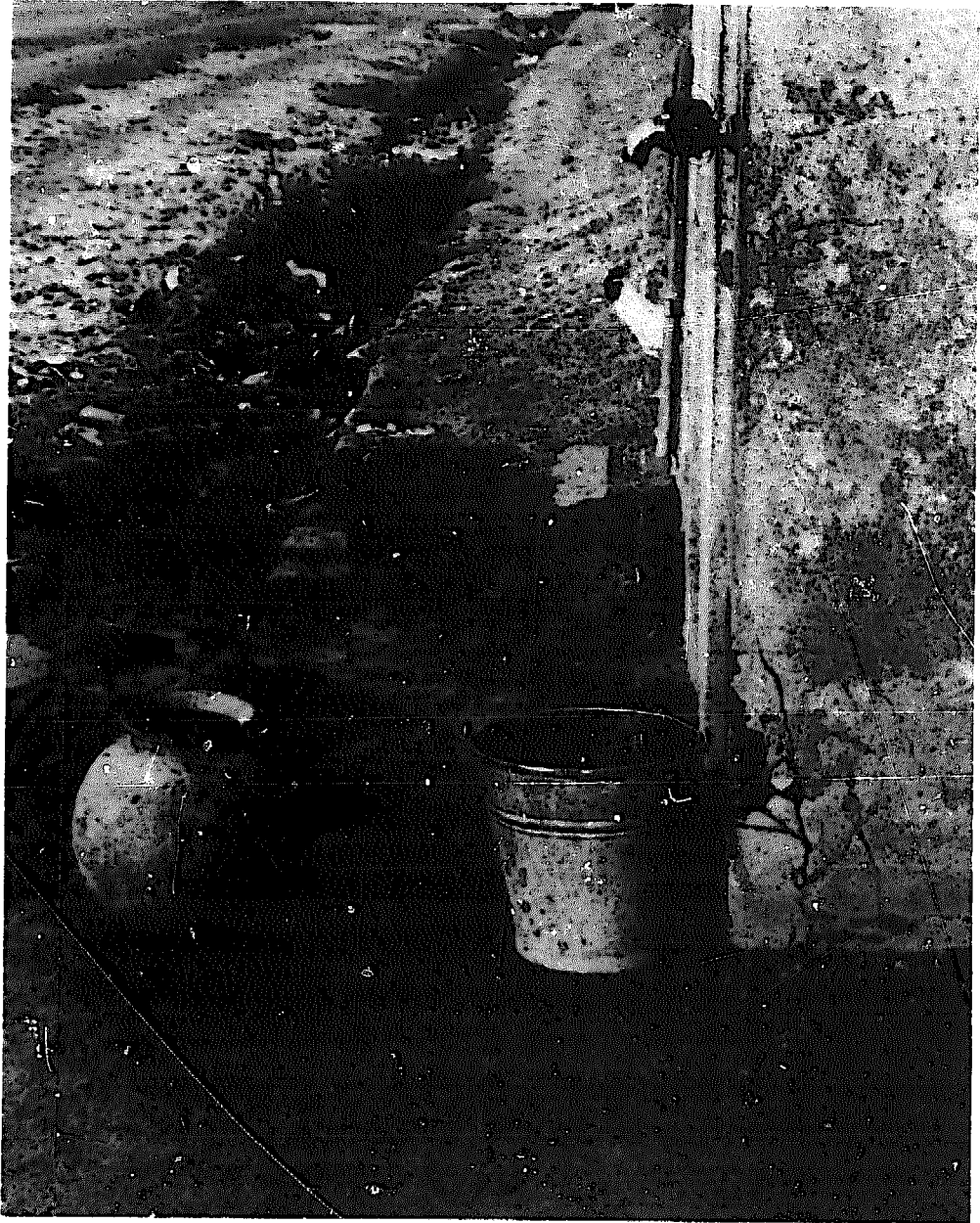

WATER WASTAGE: DISADVANTAGE OF A TAP NOT UNDER CONSTANT SURVEILLANCE

parts, and operate stock control systems which anticipate in future demand for parts, so that they can be ordered in advance. It is preferable, where possible, to use equipment which is manufactured locally.

The key to good stock control, and to other aspects of maintenance, is record keeping. If all visits of maintenance staff to standposts, and the materials used by them, are recorded, it is possible to see at what rate different components are being used. The same records make it possible to check that each standpost is serviced regularly, and can help to identify trouble spots where repairs are being called for more often than average.

SUPERVISION

Supervision of the use of public standposts at all times is advisable in the following situations:

- (a) where water is paid for directly according to volume, to collect revenues;
- (b) where there are severe water shortages and it is strictly necessary to avoid wastage and spillage;
- (c) where pressures are low and the supply irregular, to prevent users damaging the structure in attempts to increase water flow;
- (d) in crowded urban areas or where there are large numbers of users, to maintain order and prevent misuse.

Supervision is usually arranged by stationing a guard at each standpost. But if he is there only during daytime, the solution to problems of theft or damage is only partial. It may be necessary to provide a 24-hour guard service. Another approach is to place the public taps inside an enclosure or kiosk in which the guard sits and operates the taps.

The kiosk is then locked at night. This seems to be the most effective method so far devised for collecting revenues and preventing damage. However, guards must be adequately paid and made to feel that their job is important. Where pay is rock bottom and morale is low, guards may be unwilling to exercise their authority and risk unpopularity with the local community, or even fail to fulfil their duties altogether.

REVENUE COLLECTION

Collecting revenues from users is a problem that is frequently mentioned. In many countries there is *widespread antipathy* against paying for water which has to be carried home.

Poor administration, irregular collection of payment, and a poor standard of service all decrease people's willingness to pay. Besides, the financial circumstances of the users are important: those with a regular income are more likely to be able to pay a monthly sum than those who have not; the latter group often prefers to pay on the spot according to quantity used.

It is important to devise *an appropriate method of collecting payments* which is both fair and effective. Several methods are available:

- (a) charging through a monthly payment;
- (b) charging according to quantity of water used, per bucket or per Debbie, with coins or tokens;
- (c) charging by head tax, land tax, or levies on cattle;
- (d) adding charges to house rents and collecting both together;
- (e) in poor areas where the municipal council wishes to provide water free to users, the supply may be metered, and the municipality may then pay the water authority's bill.

In official urban low-cost housing areas, where people sometimes share a water tap with a number of other households, it may be particularly appropriate to include a fixed water rate in the monthly house or plot rent. Authorities face fewer problems when water charges are collected this way.

Some problems are frequently encountered where guards or concessionaires operate the standposts. They may abuse their position by demanding an inflated price for water, or by opening the tap only at hours convenient to themselves. They may lack the authority to maintain order or to insist on payment, or they may fail to fulfil their duties through being afraid of losing popularity. It is not uncommon for them to neglect the installation, so that its state of maintenance deteriorates. Selection of the right person for the job is therefore essential.

Another problem may arise when the smallest coin in use is worth, say one dollarcent. Payment of one coin for every bucketful (c.10 l) would imply a price of approximately US\$ 1,00 per cubic metre. In such circumstances, it may be desirable to have users pay for water by means of tokens which they can purchase in quantity. Then the "one cent coin" might buy tokens, entitling the user to, for instance, two to five buckets of water.

In areas where several systems of revenue collection co-exist, special problems may arise. For example, in some squatter settlements, people refused to pay the flat rate for water from the public standpost because they believed that neighbours in an adjacent area, whose water charges were included in their house rent, were not paying at all. In this instance, there should have been a clear statement of the amount of water charges added to the rent.

It depends on the local customs and the political situation in a country which arrangement for revenue collection will give the most satisfactory results.

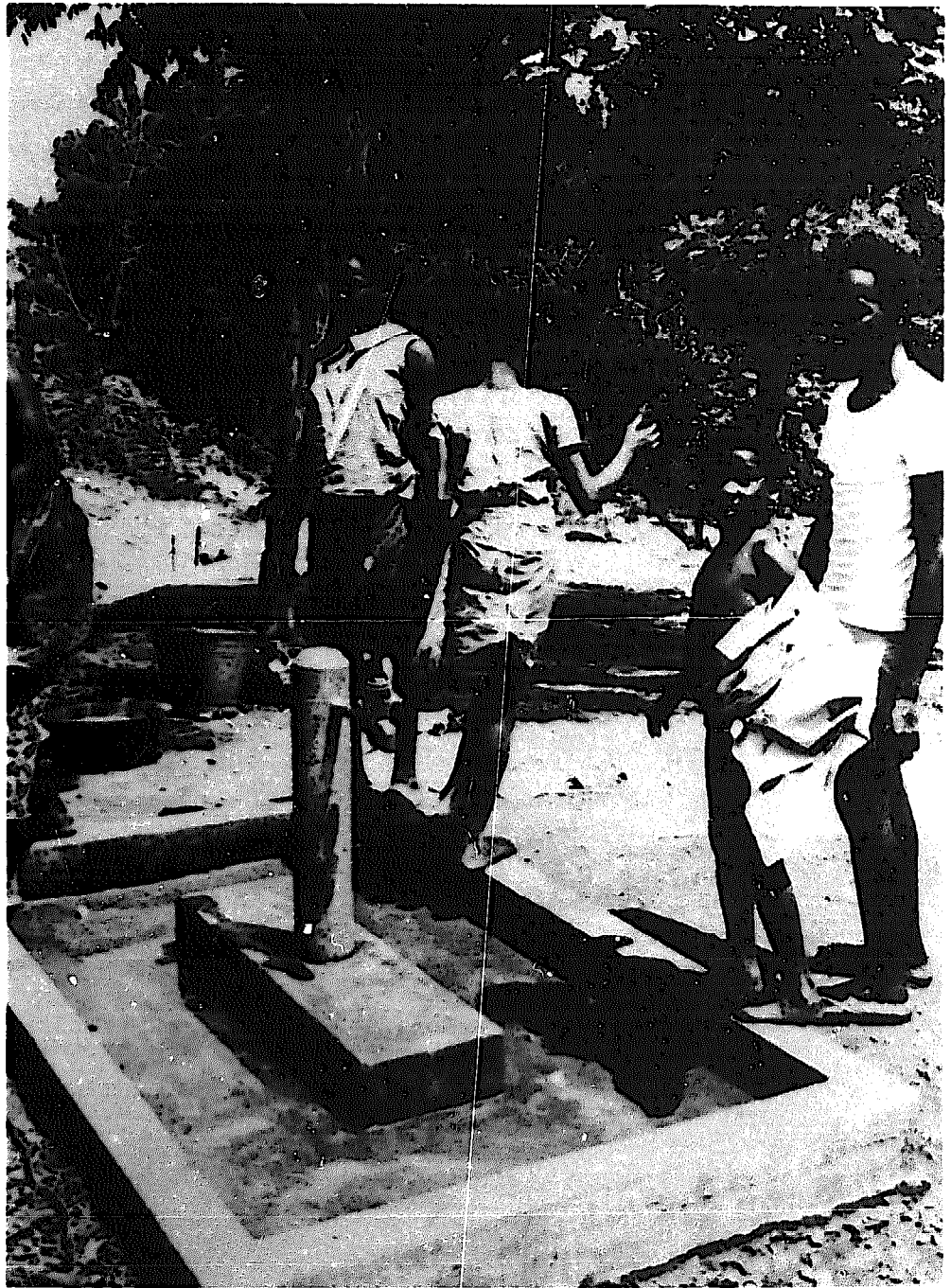

DRAINAGE

V COMMUNITY PARTICIPATION

It is generally considered important to involve the users in the planning and implementation of public standpost water supplies, to the greatest possible extent. Active community participation can be beneficial both for the success of the water supply project and for the development of a spirit of self-reliance in the community.

PARTICIPATION IN THE PLANNING

It will be evident that during the planning of a public standpost system there must be extensive contacts between the planners and the local people in the area to be served. The persons responsible for making these contacts may at the same time be acting as community workers, preparing the local community for the new development. Ideally, this community work will be carried out in such a way as to encourage an active participation of the local people in the planning, implementation and operation of the new water supply scheme, and have them state positively what facilities they want.

The participation of the community in planning requires that consultation takes place before any decisions are taken on the installation of a water supply system with public standposts, or before standposts are rejected in favour of household-connections. For participation to be meaningful, the full range of options should be presented to the community, with a clear

indication of the costs which will have to be borne by the users. Therefore, before the community is consulted, an approximate costing of the options will have to be made, and a decision taken on the amount of subsidy which can be provided from sources outside the community.

Some kind of committee or working group is nearly always of value as a focal point at which external inputs and local knowledge can be brought together. Public meetings may be more effective in ensuring that decisions represent a wide concensus, but even at public meetings it may well be that poorer people feel unable to speak out when any objection of theirs may be overridden. In order to establish the true views of all sections of the community, it may be necessary specifically to *approach the poorer section separately*, outside the context of a public meeting or the presence of better-off members of the community. This might require a small survey or might be done more informally by making enquiries in the various geographical sections of the community. The main requirement is that the person charged with carrying out the survey or the enquiries is fully conscious of the issues involved, and is sensitive to them.

In conclusion, it should be clear that planning a public standpost system requires first the definition of planning objectives, and then communication with the potential users of the system to ascertain their needs and aspirations, and to check that the planning objectives and users' goals are mutually compatible. This process of communication, should ascertain particularly what factors will make for a socially acceptable standpost, and what are the organizational strengths and weaknesses of the local community.

IMPLEMENTATION

Where community participation in construction is the aim, care must be taken that plans make maximum use of the resources which communities can provide, so that the limited resources of the agency can be used effectively in order to benefit the largest possible number of communities.

If a village has taken the initiative in asking for standposts and in collecting funds, the chances of cooperation during the actual construction of the supply are clearly good. The one exception is where a part of the community is less enthusiastic, whether for reasons of factional dispute or for socio-economic or cultural reasons.

In meetings held with the community prior to the construction of a water supply, the agency should make its position on contributions expected from the community clear from the start, both in terms of cash and in terms of labour. The community as a whole, or individual householders, may be offered the alternative of a cash or labour contribution, or households contributing labour may be offered a specified reduction in the subsequent charge for water.

Where the water agency seeks active community participation mainly in the construction phase (and not subsequently in operation), and where the local community has well-established patterns of communal labour or organizing construction of communal facilities, there may be no need for special organizations to be created. Attention need only be paid to good liaison with existing community bodies - ensuring that the work done by communal labour is well coordinated with agency requirements, the arrival of materials etc.

Otherwise, however, it will be desirable to establish a water committee, or public health committee, perhaps as a sub-committee of any more general council or improvement committee that exists.

PARTICIPATION IN OPERATION AND MAINTENANCE

Effective community participation in operation and maintenance may be more difficult to organize than participation in construction. Enthusiasm can be generated for a short-term effort with a conspicuous physical result, an effort in which everyone has his part to play. It is hard to generate enthusiasm for unglamorous and inconspicuous work which must be carried out indefinitely and which must in the main be done by one or two individuals rather than the community as a whole. Such work cannot be shared fairly by all beneficiaries, except on a rota basis which is unlikely to be workable. It must therefore be done by volunteers or by paid workers. There are difficulties in maintaining the motivation of volunteers who do a great deal of rather thankless work in their spare time.

In many instances it will be necessary to arrange for a community member to be appointed caretaker. He will be responsible for routine maintenance and supervision, and receive a small stipend. Many communities have difficulties in regularly collecting funds for such salaries. The water agency is often better structured administratively than the community, and thus better suited for making small regular payments. The problem in this case might be that there is not provision for payments for the part-time work which will generally be involved. Yet a legitimate objective of the agency will be to minimize the administrative burden arising from the water supply and to minimize the cost of running it. This will often be achieved by appointing part-time community caretakers instead of full-time workers at much higher cost.



INSTRUCTION AT THE PRIMARY LEVEL

The major tasks of a caretaker are cleaning, preventive maintenance, repair, ensuring correct use and avoiding damage, and, depending on the local arrangement, the collection of payments. He should be supported as much as possible by the water committee and/or local authority. Whether it is best to appoint a separate caretaker for each standpost location will depend on local circumstances: it may be advisable, in particular, if the locations are in socially distinguishable wards, or streets identified with particular subcommunities. If there are water vendors or others whose livelihood is affected by the installation of the new water supply, it may well be possible to employ them as caretakers.

Local circumstances will also determine whether repairs can be made the responsibility of the community. At the very least, the community should not be *prevented* from undertaking repairs unless the water authority has a maintenance organization which

can and will carry out repairs promptly and efficiently. The training requirements for caretakers and for committee members will need to be considered in the light of the extent of their responsibilities, both in technical and organizational aspects.

If the local community assumes responsibility for any repairs, it must be clearly established who is to pay for which expenses - particularly for spare parts. Since a particular repair only benefits the users of one particular standpost, disagreement or a general reluctance to pay may be expected unless the question has been clearly established in advance. Where people have little money, they are often understandably reluctant to shoulder what they see as another man's burden. Where costs and benefits can be clearly seen to be distributed fairly, cooperation can be achieved.

USE OF WATER AND IMPROVEMENT OF HEALTH

Community participation is of vital importance in the area of health education. The health benefits of an improved water supply are most unlikely to be attained to any significant degree unless there are also changes in health-related behaviour, starting with the way the water is handled after leaving the tap, but extending to all aspects of personal hygiene. These changes are most unlikely to occur on any significant scale unless there is general community involvement in the process of health education.

There is, first, a need to build up knowledge of the ways in which water-related diseases might be spread in the local conditions with existing behaviour patterns. This can be done by dialogue between community worker with "expert" knowledge of

the ways in which diseases are transmitted, and local people with their knowledge of local circumstances and behaviour. The community worker may be a health worker; or a special role of community worker may be established within the water agency, and its personnel given training in health aspects. Alternatively, a local person from the community may be selected and given training. In this case, it would be appropriate to extend the training to other basic health tasks; the persons would then act as a community health worker, just one of whose tasks would be health education in relation to water and hygiene. A number of countries are establishing community health worker programmes and there is much scope for cooperation between the water agency and the agency charged with such programmes.

Secondly, there is the need to spread throughout the community the understanding of the ways in which local habits might be changed to reduce the transmission of disease. To be effective this will need the active collaboration of a committee of local people; it could be another task for the water committee. The spread of information is insufficient by itself; there must be positive motivation to make substantial changes in behaviour. The necessary motivation may come from a thorough understanding of the processes involved in the transmission of disease; from the acceptance of authoritative assurances that adopting a given change in habits will have an effect on health; from observing others adopting the change; from the desire to be thought well of by other members of the community; or because actual sanctions are threatened against those who do not adopt the change. Which kinds of motivation can be used in particular cases will depend on local circumstances, but a local committee will be in a better position to use most of them than a community worker from outside. The community worker must, however, endeavour to ensure that the committee itself has sufficient motivation.

COMMUNITY ORGANIZATION

The effectiveness of community participation depends to a large extent on the development of an appropriate community organization. Many communities, particularly in rural areas, will possess a well-established formal organization, and the committees and local caretakers necessary for the operation of a public standpost water supply will need to fit in with this organization. That might mean that the proper place for discussion of water supplies or for the selection of people to act as caretakers is a ward meeting or an existing village committee. Very often, though, no existing organization is appropriate, and it may be necessary to form a special "water committee", or a broader "public health committee", representing the local community.

In communities where local committees seem feasible, the exact participation structure will depend on the water authority's policies. If the authority seeks active community participation in the construction phase, only, a fairly minimal development of community organization will be necessary. Thus in some places it may be possible to depend on an existing framework of meetings and consultations, and on existing leaders to organize working parties to secure cash contributions. If, however, the community is being asked to play a continuing role in operation and maintenance and in securing the full potential health benefits of the standpost, much bigger demands are made. This approach requires continuity over a long period with regard to standpost operation and second, an effort to involve the whole community, including underprivileged groups, in any health campaign. Both of these objectives can sometimes be met by the formation of a special "water committee" or "public health committee", and it will

therefore be one of the first tasks of the community worker representing the water authority to assist in the formation of such a group.

On a committee set up specifically to deal with water and health, it may be possible to include women or other people normally excluded from committees or meetings, on the grounds that they are more closely involved in water use and hygiene practice. If women and other underprivileged groups are not adequately represented on committees or at meetings, it becomes much more difficult to effect the health benefits which an improved water supply should bring.

The precise role of *water committees* will vary from place to place, but it is possible to draw up a basic list of committee's functions. In general terms, a water committee might have responsibility to do the following things:

- (a) to aid communication between the water authority and water users;
- (b) to organize self-help, voluntary labour for construction;
- (c) to draw up the rules to be observed by users of the supply, to enforce these rules, and prevent misuse;
- (d) to select local people for training as standpost caretakers, community health workers, etc;
- (e) to collect financial contributions from users;
- (f) to reimburse caretakers for any expenses (e.g. purchase of spare parts), and perhaps to pay other costs.
- (g) to make suggestions and assist with health education.

This formidable list of responsibilities represents the burden which falls on local people when a water authority devolves considerable responsibility onto the local people. Only communities with a strong tradition of formal organization and with members with a degree of managerial skill are likely to be able to undertake all these tasks successfully.

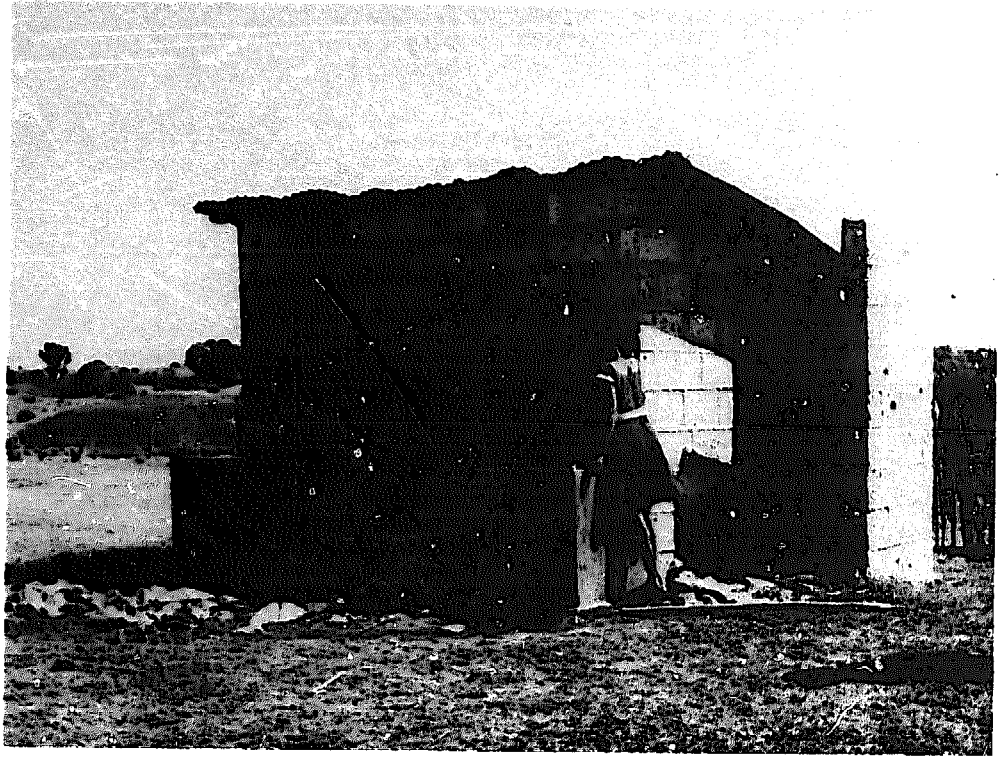

COMFORT STATION

VI TECHNICAL ASPECTS

For more detailed information on the technical aspects reference is made to the Manual on Design and Construction of Public Standposts, published as IRC Technical Paper 14, and which is considered as a companion document to this publication.

CHOICE OF TECHNOLOGY

The term "choice of technology" is often used to denote the problem of making optimum use of capital, labour and natural resources in any programme involving new technology. The designer of water supplies, is, of course, faced with the same problem, and in choosing to install a standpost system he has already made a fundamental "choice of technology".

The decision to provide standposts can be seen as the first of a series of simple steps in a logical design procedure (annex 4). The next step is to collect data relevant to the design of the standpost system, including details on where people do their laundry and what kind of platform they need to support their buckets or other containers.

Then follows an assessment of whether the community is able and willing to *organize the maintenance* of its own standposts and to *collect the necessary payments* from its own members.

It may be possible to encourage the formation of a local committee and leave the management of the standposts mainly to it.

This implies a "decentralized" pattern of maintenance which requires simple, easily maintained equipment. At the other extreme, if the community is very loosely organized a "centralized" pattern of maintenance may be more appropriate.

Such considerations should lead the designer to conclusions about the specification on which to base the *detailed engineering design*. For the purpose of discussion this subject is subdivided as follows: (a) water consumption; (b) hydraulics and capacity; (c) standpost structure and layout, and (d) selection of equipment.

WATER CONSUMPTION

The volume of water drawn from public standposts is typically between 20 and 60 litres per capita per day (lcd). The actual water consumption from a public standpost depends not only on local habits concerning domestic water use, but also on the availability of other water sources. The amount of water drawn for non-domestic uses such as watering gardens can be significant too. In designing a water supply, potential future increases in demand must be catered for. In a public standpost system, it is usually advisable to provide excess capacity for about 10 years, allowing for population growth and increase in per capita consumption during that period. Where a water distribution system with public standposts is planned to provide house connection later, the design of the treatment facility and the distribution system is often based on a use of 100 lcd. Should this prove to be too costly, a design standard of 75 lcd may be acceptable.

Another criterion is the *peak demand* for water. At public standposts in rural areas the peak demand often occurs in the early evening, when the amount of water drawn in an hour may be as much as 5 times the average hourly rate, or even more. Such high peak factors are characteristic of water supplies used solely for domestic purposes, where there is no industrial or agricultural base load. In most cases a peak factor of 3 to 5 will be adequate for the design of standpost water distribution networks.

The designer can control the peak factor to a certain extent by limiting the number of taps at each standpost, or by using flow restricting orifices. Since orifices can be inexpensively made in different sizes and can be easily inserted and removed, they are a preferred method of control.

Such a controlled peak flow, however, should not fall below an acceptable level, in order to avoid users being inconvenienced by long queues. In India, for instance, the criterion is that the discharge rate from taps at urban standposts should be 10 litres per minute, while in rural areas 5 litres per minute is considered adequate.

HYDRAULICS AND CAPACITIES

A water supply system with public standposts consists of a central source, with or without treatment facility, from which the water is piped to the public standposts for distribution. Normally, the pipe system will be branched, terminating in dead ends at the standposts. Branched systems are less expensive, and are much easier to design than systems with loops. A break in the distribution main of a branched system, however, will interrupt service to many users.

Where a number of public standposts are connected to a distribution main, it is often acceptable to assume that the water pressure in the distribution main is not much affected by water discharge from the standposts. The taps or other water-dispensing devices of the public standposts may then be considered separate from the distribution system.

It is important to choose an appropriate kind of tap, and also to ensure that the size and number of taps installed will discharge sufficient water to serve the needs of users.

If the standpost is inadequate in this respect, excessively long queues will form at peak periods, and people will be discouraged from using the standpost. As a rule of thumb, there should be one tap at a standpost for every 50 persons to be served.

To get a more precise view of how many taps are needed, it is necessary to examine the situation during peak hours. At most standposts this is either early in the morning or later in the afternoon. During the peak hours, taps may be kept wide open without interruption and the discharge of water from the taps is likely to be between 3 and 5 times the average flow. This latter ratio is referred to as the "peak factor" or "P".

Next to this a certain amount of water is spilled, or is used for rinsing out buckets, so a factor "w" is to be introduced to represent the fraction of the water that is wasted.

If the average demand per capita per day is denoted by "Cd" and the number of people served by the standpost is indicated by "N", the maximum flow at the standpost can be written as follows:

$$Q_{\max} = N \times \frac{1}{S} \times \frac{Cd}{24} \times P \times \frac{1}{1-w} \times \frac{1}{f}$$

The manufacturers of taps can usually supply a graph showing the water discharge rate of a particular tap, at different feed pressures.

The minimum allowable pressure in a system may be as low as 5 metres ($0,5 \text{ kgf/cm}^3$), but design pressures between 8 and 20 m are common. Many engineers favour values on the low side (around 10 m) to minimize leakage from the network.

The number of taps required at a public standpost obviously depends on the ratio of the required flow (Q_{max}) to the discharge capacity of one tap (q_d), and part of the designer's task is to choose taps of such dimensions that this ratio gives a convenient number of taps. To reduce the discharge capacity of a tap, an orifice can be fitted in the service pipe.

A separate calculation is necessary to determine the diameter of the service pipe. Knowledge of the water pressure in the mains, the desired pressure at the tap, and the length of pipe allows the hydraulic loss in the pipe to be calculated. Manufacturers of pipes provide charts showing what diameter pipe will be required to discharge the required peak flow.

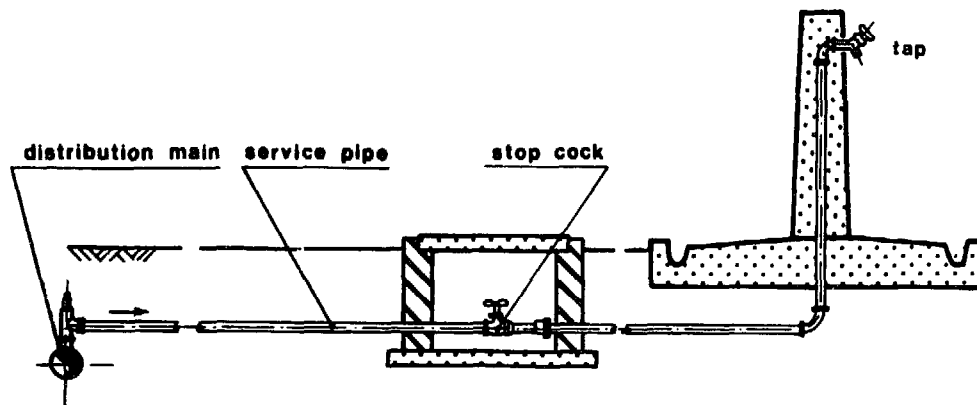
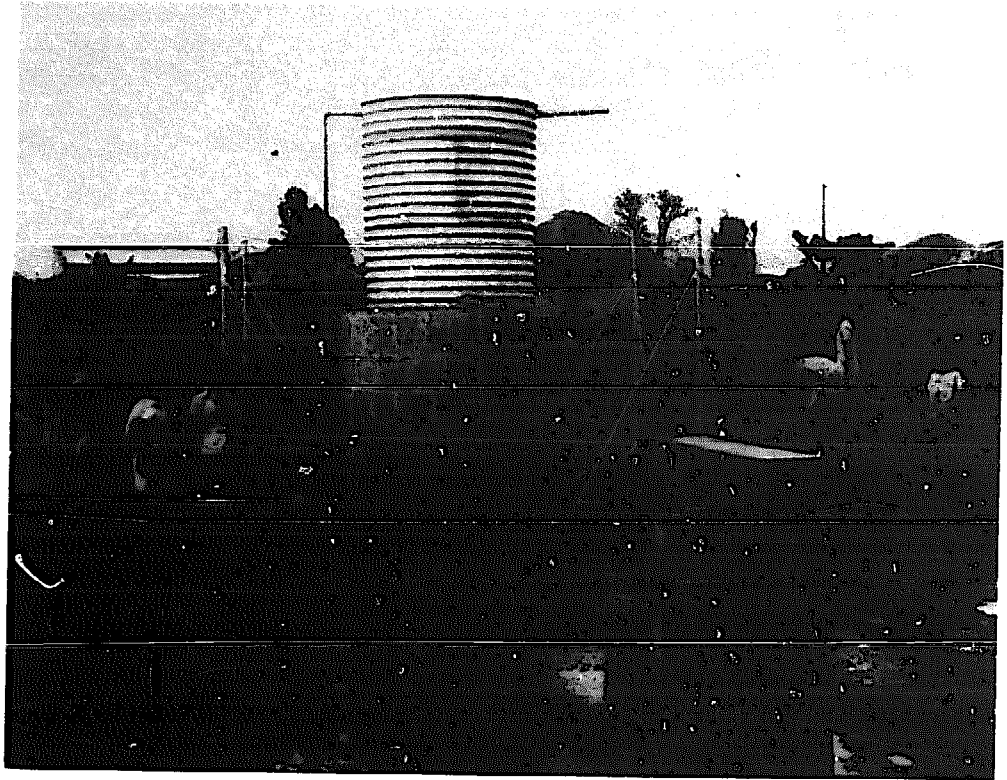

FIGURE 5: TECHNICAL ELEMENTS OF PUBLIC STANDPOSTS



WATER MAY BECOME CONTAMINATED AT ANY POINT

STANDPOST STRUCTURE AND LAYOUT

A standpost structure consists of the wall or post which support the taps and the platform. The floor-surface should be hard and impermeable, and should slope towards some type of drain where waste water can run off. To ensure good drainage, the floor-surface should be raised about 0,10 m above the surrounding ground.

Two basic types can be distinguished. In the simplest and most widely applicable design the floor slopes away from the tap to trenches or soak-away drains at its outer edges (outward slope). Another type has the floor sloping towards the taps (inward slope), with a drainage channel let into the floor below the taps and discharging into a pipe at one end (annex 6).

The latter type of standpost drainage is likely to be relatively costly to construct, and will be justified mainly in urban areas where soak-away drains cannot be used. This type also presents a slightly greater contamination risk than does the outward sloping platform. If the drainage pipe become blocked, the standpost will be surrounded by a pool of stagnant water. It should therefore be used only where maintenance is adequate and drains are kept clear.

In rural areas, where relatively few persons use any one standpost, it may be desirable to economize by dispensing with a hard floor-surface altogether, in which case a soak-away drain is made directly under the tap. This soak-away should consist of a pit of, say, 0,50 m square and 0,80 m deep, filled with rubble or gravel through which spilled water can drain into the soil. The rubble infill should be built up to a suitable level to provide the necessary stand for buckets. Such an arrangement

can work well where soil is permeable and drainage is effective, but should be avoided in places where the ground easily become water-logged.

Wherever it is possible to carry away the waste water in drainage pipe, the water ought preferably to be put to some further use, such as: drinking water for cattle; the irrigation of gardens; or a fish pond.

When use of the waste water is impossible, direct discharge to any existing storm drain or canal is recommended, or the water may be infiltrated into the ground by means of soakage trenches or the number of seepage pits should be decided according to the permeability of the soil - clay soils will require relatively long trenches and sandy soils short ones.

The standpost floor or platform can be made from concrete or any suitable locally available material (brick, stone). The taps need to be well supported by a structure with a strong foundation. Too often the construction is inadequate, with sometimes just an unsupported pipe sticking out of the ground. Broken connecting pipes frequently result from this. Sometimes the rising pipe is strengthened; for example, by using 25 mm steel piping. It is, however, better to encase the pipe in masonry, or to attach the pipe and tap to a pillar or a wall.

There may be a need for small platforms or stands directly beneath the taps, on which users can place their buckets or other containers for filling. Where people carry containers on their heads, the height of these platforms about the ground should be 0,9 - 1,0 m for adults and 0,4 - 0,5 m for children. The height of the taps above these stands range between 0,4 to 1,0 m, depending on the manner of operation and the size of the containers used. In many countries, simple stands of brick or concrete are made underneath each tap, though where investment funds are less limited, metal gratings on which to stand the buckets may be used.

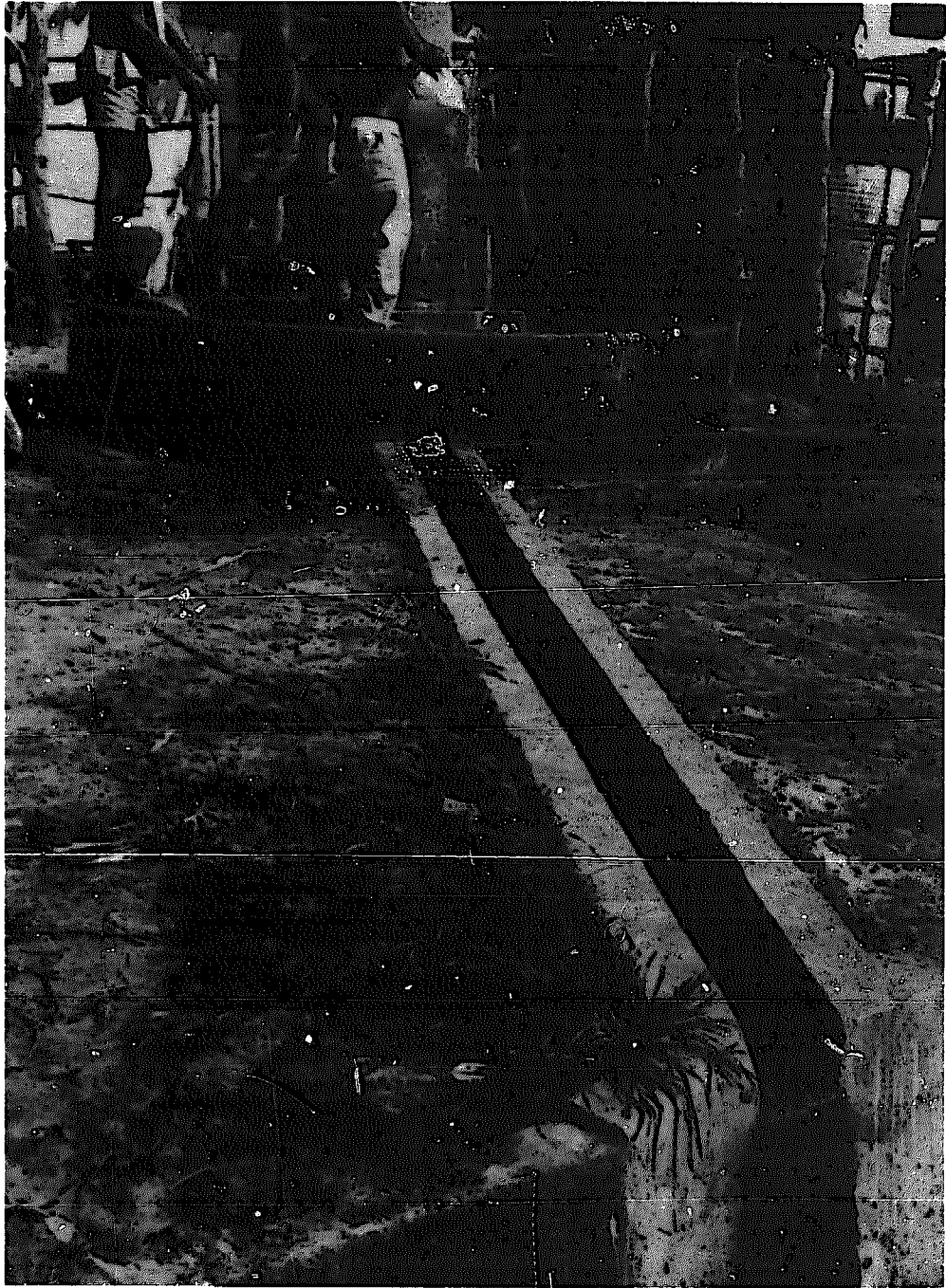

STANDPOST WASTE WATER DRAINAGE CHANNEL

Apart from the basic components of standposts so far described, the layout of the standpost platform may include other features, depending on the preference of users or on the provision to be made for supervision and revenue collection. Some kind of enclosing wall around the standpost may be demanded by the users, or may reduce supervision problems if the wall has a gate which can be locked. If no such arrangement is called for, a protective curb at the edge of the standpost platform may be advisable to keep away traffic from adjoining roads or to prevent cattle from getting onto the platform. This curb may take the form of a raised border, 0,20 m high where traffic is the problem, or may consist of a low wall, 0,80 m high where damage from cattle is expected. If the latter risk is great, it would be wise to have a cattle grid at the entrance. Separate troughs should be provided if livestock are to be watered and these should be situated outside the public standpost enclosure.

If there is a need for laundry and washing facilities, they should be provided near to, but separate from the standpost. Laundry may require only simple arrangements - slabs, sinks and shelter. Alternatively, a "*comfort station*" may be required, incorporating public toilets, showers and washing rooms. To construct a public standpost as part of a comfort station offers a number of technical advantages: the same service piping can supply water for all facilities, and the waste water can be discharged to the sewage system of the comfort station. The public taps should be located outside the outer wall of the comfort station.

ANNEXES

CHECKLIST FOR INTEGRATED PROGRAMME DEVELOPMENT

COMPONENTS	ELEMENTS
PLANNING	integration in national programme feasibility studies budget and financing
INSTITUTIONAL and ORGANIZATIONAL INFRASTRUCTURE	institutional framework legislation organization administration
RESEARCH and DEVELOPMENT	field investigations testing pilot studies
TECHNICAL ENGINEERING	design construction operation maintenance standardization
MANAGEMENT and ORGANIZATION	administration charges policy revenue collection system operation and maintenance indigenous manufacture
ECONOMICS and FINANCE	economic viability investment cost/recurrent costs cost effectiveness analysis financing arrangements revolving funds price structure
MANPOWER DEVELOPMENT	recruitment training courses, manuals, facilities
COMMUNITY DEVELOPMENT	surveys public information community participation sanitation

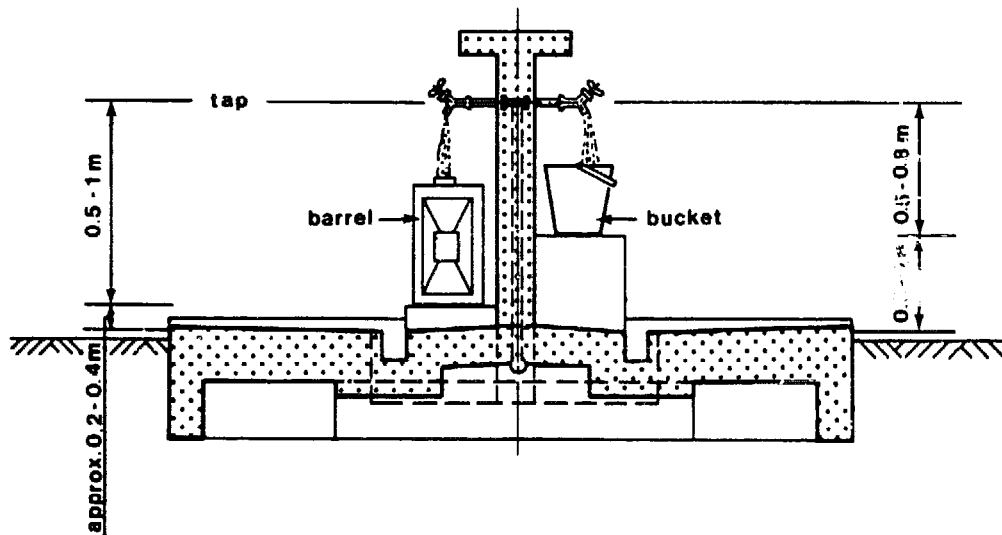
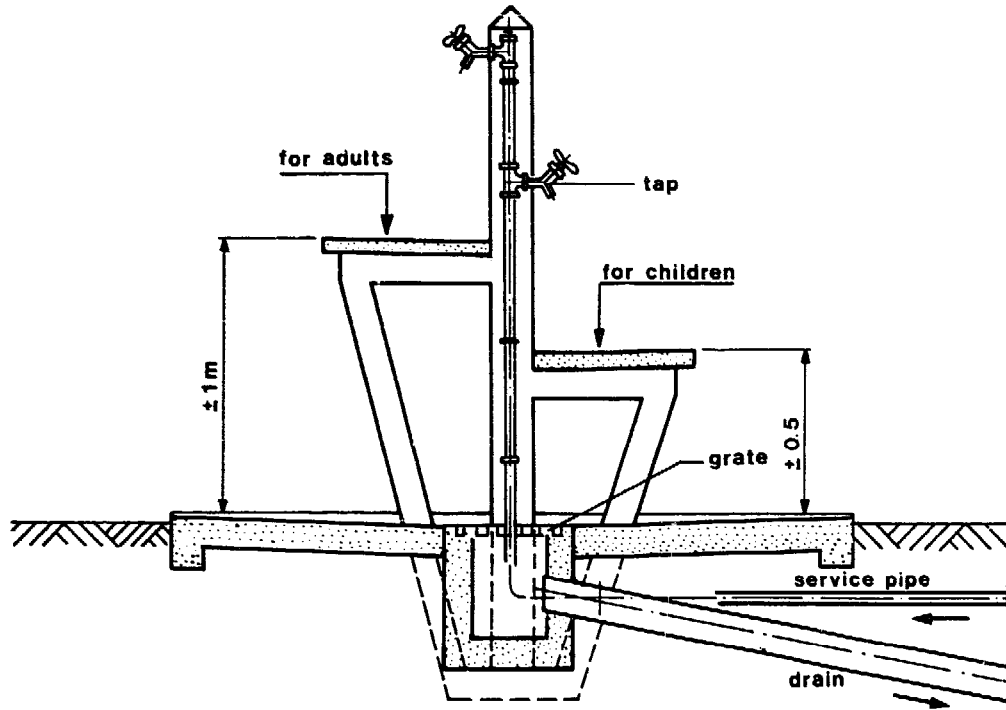

STANDPOSTS WITH RAISED PLATFORM

- (a) to accommodate different categories of users
- (b) to allow containers of different sizes to be used.

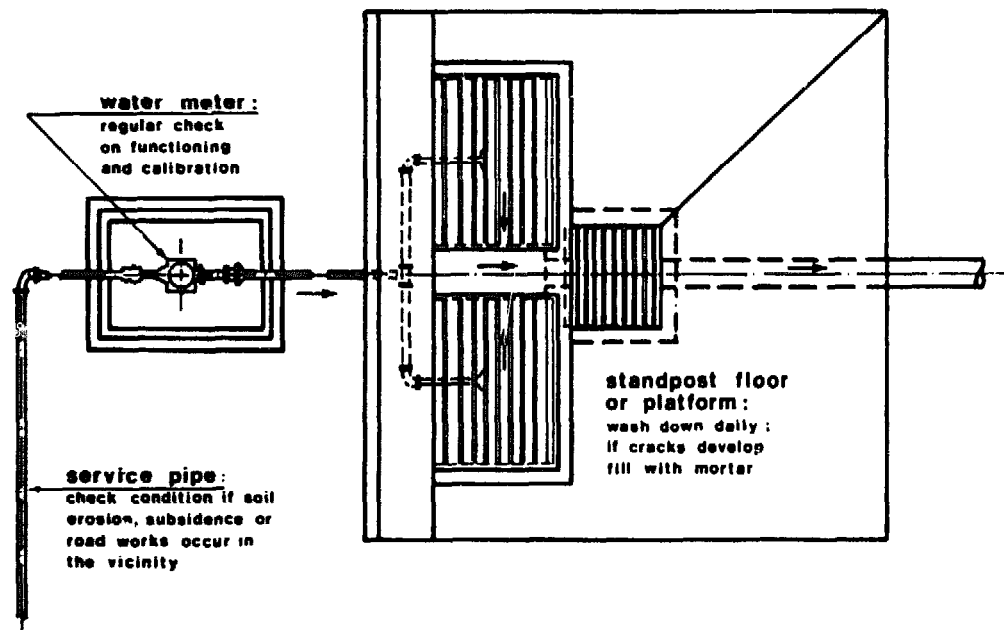
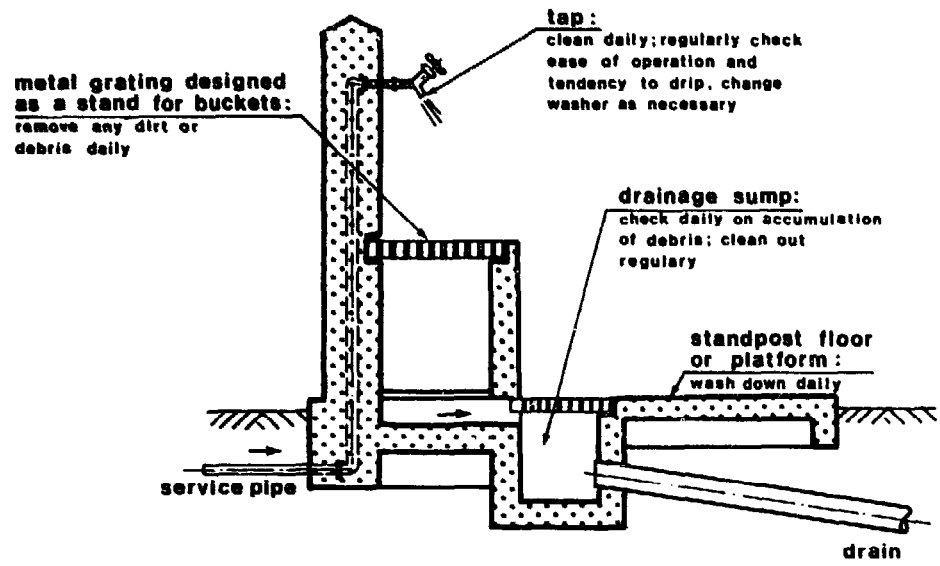

MAINTENANCE POINTS OF A STANDPOST

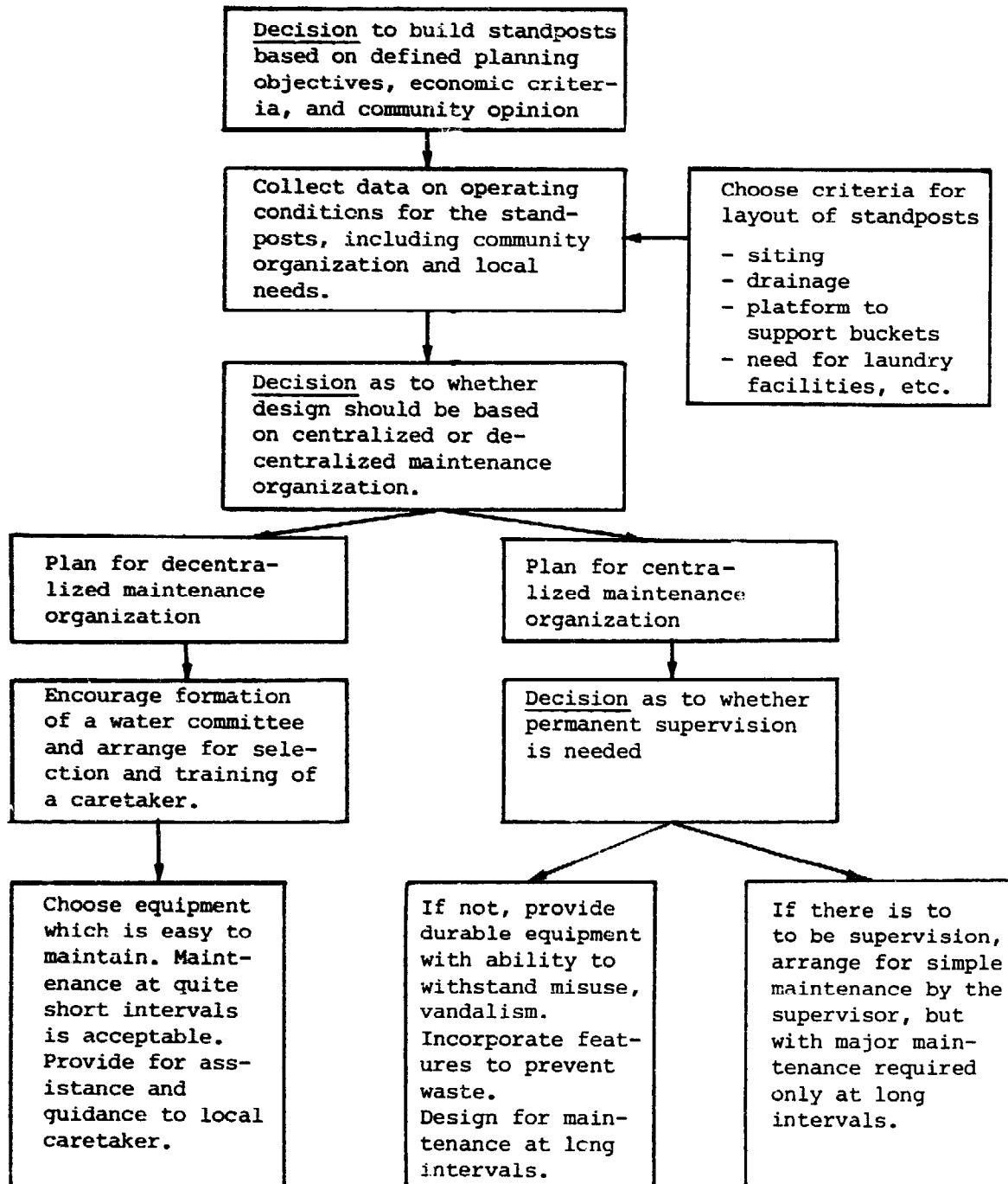
PROCEDURE FOR STANDPOST DESIGN

ANNEX 5

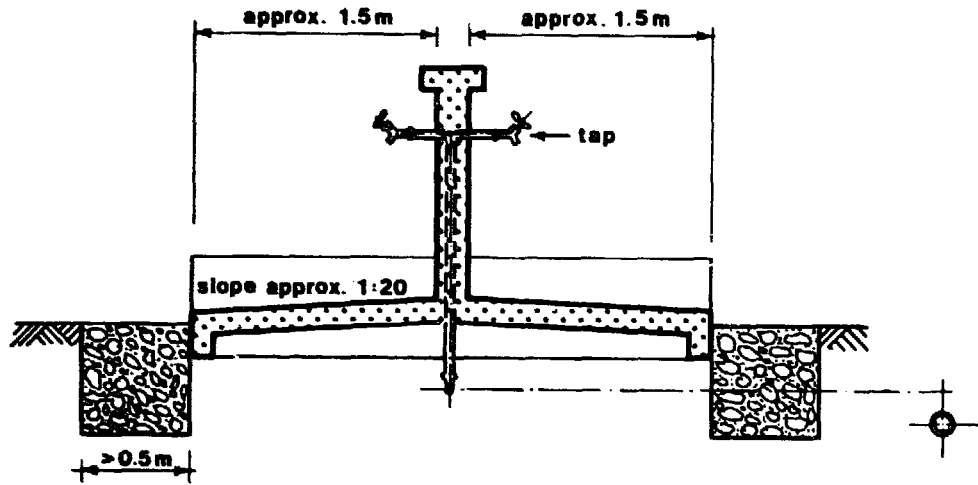

FIGURE A: CROSS-SECTION OF STANDPOST WITH TWO SCREW TAPS AND A CONCRETE PLATFORM

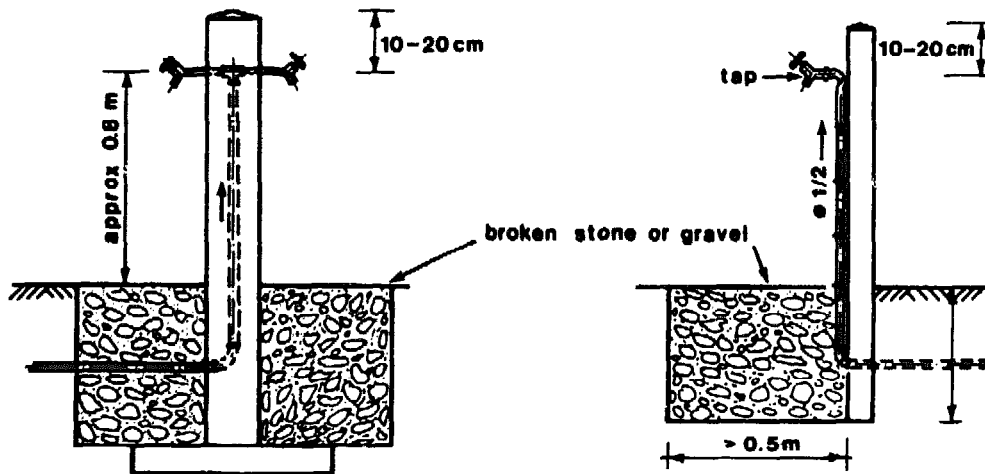
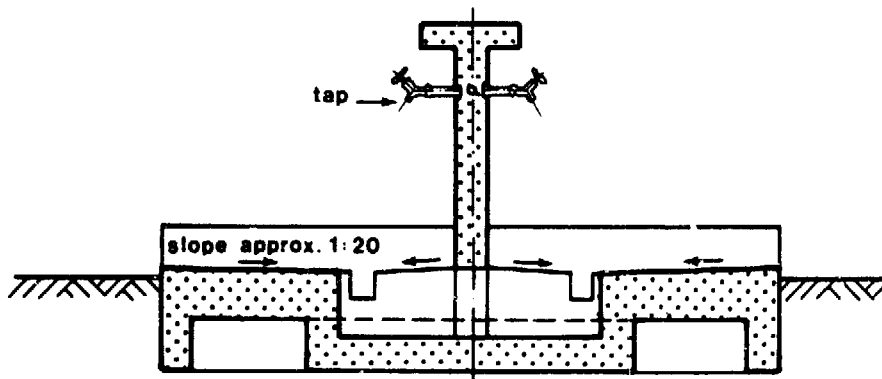
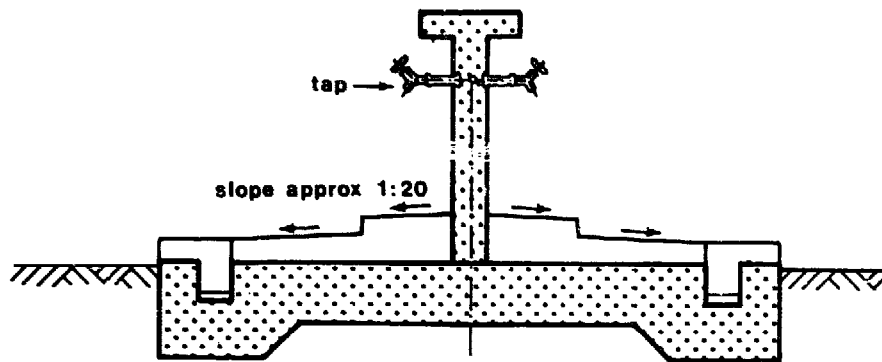

FIGURE B: CROSS-SECTIONS OF SIMPLE STANDPOSTS TYPICAL OF RURAL WATER SUPPLIES



TYPICAL ARRANGEMENTS FOR WASTE WATER DRAINAGE

LIST OF REFERENCES

1. APPLEYARD, J.R.
Least Cost Design of Branched Pipe Network Systems
Journal of Environmental Engineering Division
101, EE4, 1975, pp. 675-677
2. BORJESSON, E.K.G.
Low Cost Distribution Systems, in Water for Peace Conference
Planning and developing water programmes, U.S. Government
Printing Office, Washington, D.C., Vol. 7, 1967
3. CAIRNCROSS, S.; FEACHEM, R.
Small Water Supplies
Ross Institute, London, Bulletin 10, 1978
4. CAIRNCROSS, S.; et al
The Evaluation of Village Water Supplies in Lesotho
Planning for Water and Waste in Hot Countries, ed. John Pickford,
Loughborough University of Technology, England, 1976
5. CARRUTHERS, I.D.
Impact and Economics of Community Water Supply
Wye College, University of London, Ashford, 1972
6. COMMISSION OF EUROPEAN COMMUNITIES
Sector Evaluation (ex-post) of Urban and Village Water Supply Projects
Vols. I and II, Brussels, 1978
7. DEVELOPMENT PLANNING UNIT
Seminar on Planned Growth in Lusaka
Univeristy College, Development Planning Unit Research Team,
London, 1974

8. DONALDSON, D.
Planning Water and Sanitation Systems for Small Communities
In: International Training Seminar on Community Water Supply in Developing Countries,
WHO International Reference Centre for Community Water Supply,
Bulletin No. 10, 1976, pp. 71-105
9. EPP, R.; FOWLER, A.G.
Efficient Code for Steady State Flows in Networks
Journal Hyd. Division, American Society of Civil Engineers,
96, HY1, 1970
10. FARRAR, D.M.
Aspects of Water Supply and Conservation in some Semi-arid parts of Africa
Institute of Science and Technology, University of Manchester,
Ph.D. thesis, Manchester, 1974
11. FEACHEM, R.
Water Supplies for Low Income Communities: resource allocation planning and design
In: Water, Wastes, and Health in Hot Climates
ed. R. Feachem, M.G. McGarry and D. Mara, John Wiley & Sons,
London and New York, 1977, pp. 75-95
12. FEACHEM, R.
Water Supplies for Low Income Communities in Developing Countries
Proceedings of American Society of Civil Engineers, 101, EE5,
1977, pp. 687-702
13. HUGHES, A.J.B.
The Inter-relation of Social Structure, Land Tenure and Land Use.
Paper presented at Bulawayo Conference, National Resources Board,
Zimbabwe, 1967
14. HUMPHREYS, HOWARD & SONS
Seven Urban Water Supply Schemes in Ghana
World Health Organization, Geneva, 1970

15. INTERNATIONAL REFERENCE CENTRE FOR COMMUNITY WATER SUPPLY
Public Standposts for Developing Countries
Proceedings of an International expert meeting held in Achimota,
Ghana, August 1977, Bulletin Series No. 11.
16. INTERNATIONAL REFERENCE CENTRE FOR COMMUNITY WATER SUPPLY
Manual for Design and Construction of Public Standposts
Technical Paper Series No. 14, September 1979
17. LAURIA, D.T.; KOLSKY, P.J.; MIDDLETON, R.N.
Design of Low-cost Water Distribution Systems
The World Bank, P.U. Report No. RES 11, Energy, Water and Tele-
communications Department, Washington D.C., 1977
18. MARAIS, G, van ROOYEN,; McJUNKIN, F.E.
Reduction of Water Consumption by Use of Constant Flow Valves
University of North Carolina, AID-UNC/IPSED Series Item 2, 1969
19. PACEY, A. ed.
Water for the Thousand Millions
Pergamon Press, Oxford, 1977
20. REES, I.
Urban Infrastructure Problems: a case study of water supply
Paper for the Town and Country Planning Overseas Summer School,
London, 1972
21. ROBINSON, R.B.; AUSTIN, T.A.
Cost of Optimization of Rural Water Systems
Journal Hyd. Division, American Society of Civil Engineers,
102, HY8, 1976, pp. 119-1134
22. ROURE, J.
Standpipes in Tropical Africa
Information and Documents, no. 3, 1975, pp. 15-26

23. SAUNDERS, R.J.; WARFORD, J.J.
Village Water Supply: Economics and Policy in the Developing World
John Hopkins University Press, World Bank Research Publication,
Baltimore and London, 1976
24. SOCIETE D'ENERGIE ET D'EAU DU GABON
Projet d'aménagement et d'entretien des bornes fontaines dans
les quartiers non-urbanisés de Libreville,
Libreville, 1972
25. TASGAONKAR, S.K.
Norms for Design of Rural Pipad Water Supply Schemes
Journal Indian Water Works Association, January-March 1978,
pp. 97-102
26. UNICEF
A Strategy for Basic Services
United Nations, New York, Code 378-76-10M, 1976
27. WAGNER, E.G.; LANOIX, J.N.
Water Supply for Rural Areas and Small Communities
World Health Organization Monograph Series No. 42, Geneva 1959
28. WARFORD, J.J.; JULIUS, De. A.S.
The Multiple Objectives of Water Rate Policy in Less Developed
Countries
Water Supply and Mmagement, Vol. 1, pp. 335-342, 1977
29. WARNER, D
The Economics of Rural Water Supply in Tanzania
University of Dar-es-Salaam, ERB Paper, 1970
30. WATER RESEARCH ASSOCIATION
Final Report of WHO-assisted Course on Preventive Maintenance of
Water Distribution Systems
held in Bombay, India
Water Research Association, Marlow, 1972

31. WHITE, A.T.
Health Extension in Phase 2 of the Slow Sand Filtration Project
International Reference Centre for Community Water Supply, The Hague, 1978 (unpublished)
32. WHITE, G.F.; BRADLEY, D.J.; WHITE, A.U.
Drawers of Water; domestic water use in East Africa
University of Chicago Press, Chicago and London, 1972
33. WORLD HEALTH ORGANIZATION
Community Water Supply, a Report of a WHO Expert Committee
World Health Organization, Technical Report No. 420, Geneva, 1969
34. WORLD HEALTH ORGANIZATION
ECA Working Group of Experts in Water Resources Planning
Geneva, June 1970
35. WORLD HEALTH ORGANIZATION
World Health Statistics Report
Vol. 26, No. 11, WHO, Geneva, 1973
36. WORLD HEALTH ORGANIZATION
Provision of Safe Water Supplies to Rural Communities in South East Asia
WHO Regional Office for South East Asia, New Delhi, 1974
37. WORLD HEALTH ORGANIZATION
World Health Statistics Report
Vol. 29, No. 10, Geneva 1976

INDEX

A

administration, 45; see also
management
appropriate technology, 35, 43

B

base units, see platforms
benefits and costs, 5-6, 21, 27
see also health benefits
buckets, stands for, 38, 78, 85

C

capacities, see discharge
capacities
capital costs, 23, 34, 62;
see also recurrent costs
caretakers, 51, 54, 68, 69
caretakers' wages, 64
carrying water, 28, 38-9, 78
cattle watering, 12, 78
centralized maintenance,
54, 72, 89
clearing standposts, 43, 53, 54,
65
comfort stations, 70, 80
communication and liaison, 51-2,
61-3, 69
community contributions, 28, 29, 63
community organization, 68-9, 71-2
community participation, 29, 35,
48, 61-9
community workers, 61, 66-7, 69

consumers, see users
consumption per capita, 27, 31,
72-3
contamination, 21, 43, 55, 77
cost-benefit analysis, 22, 26-7
cost of construction per capita,
10, 25, 26
cost of maintenance, 28, 31, 55
cost of water, 31, 59
cultural factors, 38, 40-1

D

data collection, 71
decentralized maintenance, 54,
72, 89
design life, 12, 72
design manual, 71
design of organization, 44, 49
design procedures, 71, 89
design standards, 26-7
discharge capacity, 73-5
disease, water-related, 21, 66
distribution systems, 13, 18,
23-4, 26, 73-5
drainage, 12, 18, 77-8, 93
drinking water decade, 5

E

economics of standposts, 21-34
education, 19, 22, 32, 33, 66-7