

1



AT MICROFICHE
REFERENCE
LIBRARY

A project of Volunteers in Asia

A Hand-Operated Winnowing, Rural Technology Guide No. 11

by J. Beaumont

Published by:

Tropical Products Institute
56/62 Gray's Inn Road
London WC1X 8LU
ENGLAND

Available from:

same as above

Reproduced by permission.

Reproduction of this microfiche document in any form is subject to the same restrictions as those of the original document.



A hand-operated winnower

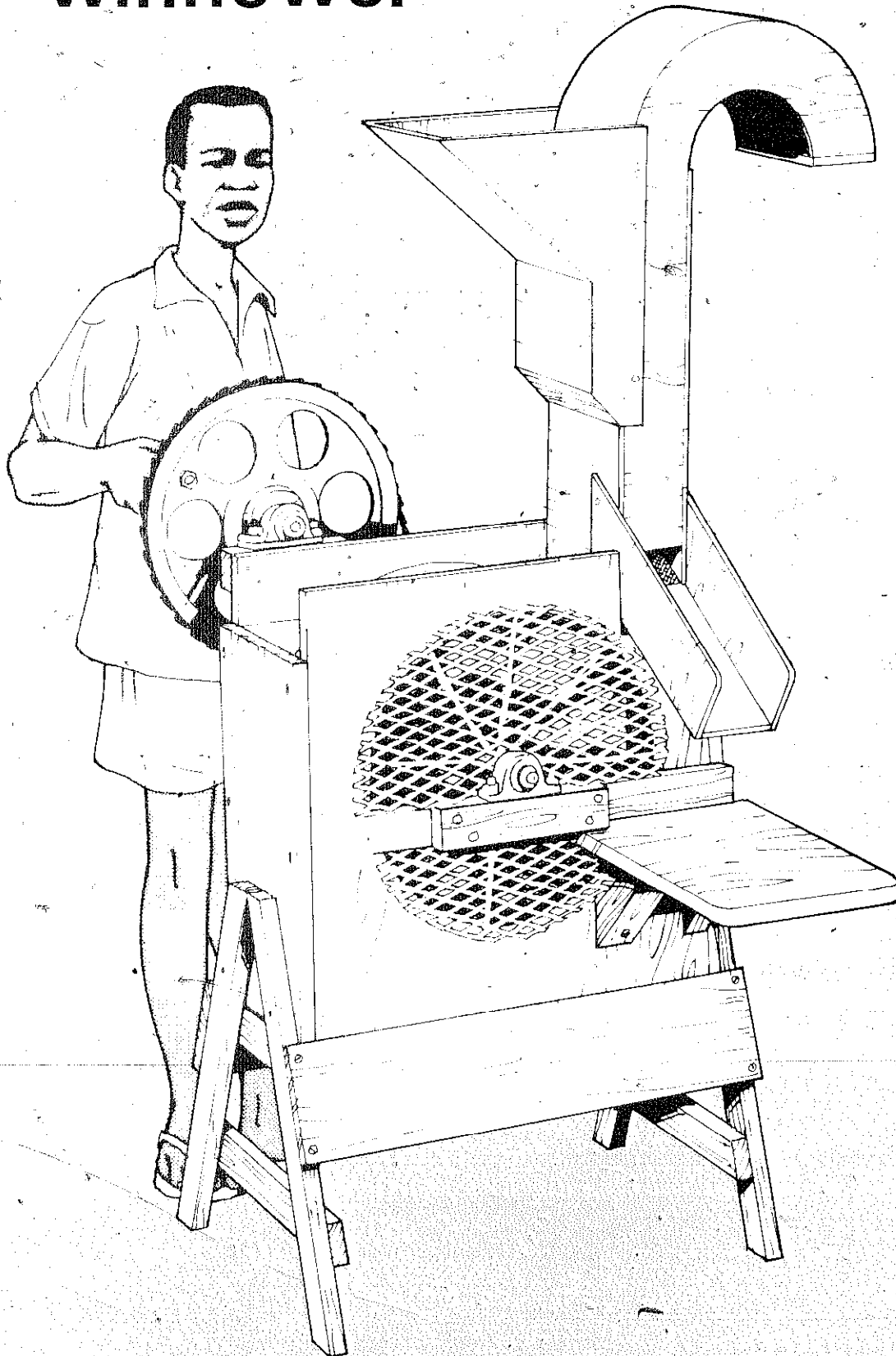

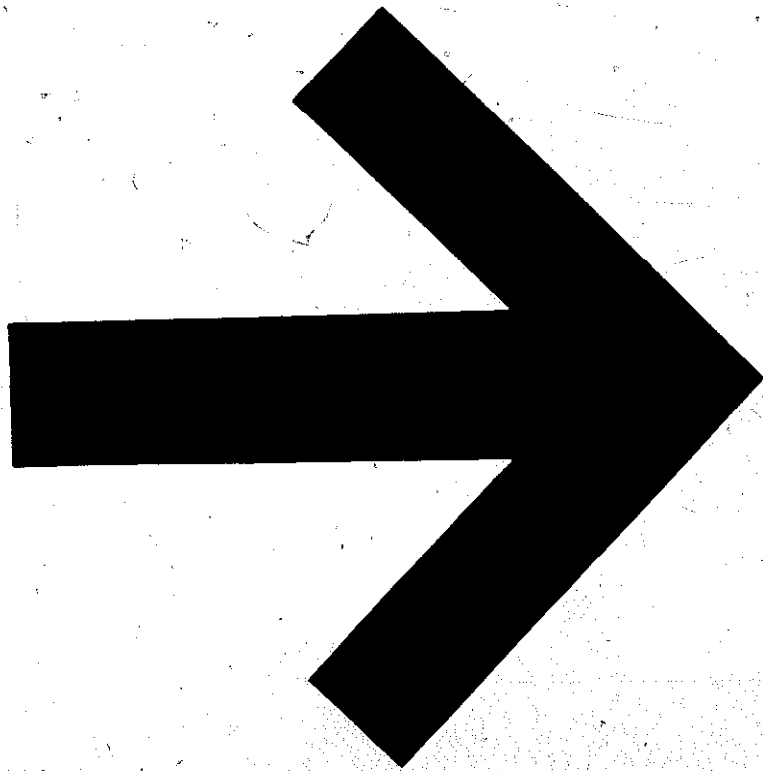

A hand-operated winnower

J H Beaumont

Contents

Introduction	1
Description	2
Manufacture	4
Parts and materials list	5
Winnower body	6
Wind case	9
Saddle	14
Fan	17
Assembly	20
Operation	25

Introduction

This guide describes how to make a hand-operated winnower for separating kernel from shell or husk, using materials which are generally available locally.

Most of the parts are made of wood but they can be of metal if this is cheaper or easier for you to obtain. For instance, the fan blades can be cut from a metal tin or drum and screwed to the fan boss.

Bearings can be made of hardwood, or of metal tubing clamped in a wooden block. Alternatively, a metal block with a hole bored to the right size to take the shaft can be used. Bearings must be kept well lubricated.

Pulleys can also be made of wood and, if adjustable belting is not available, an old car fan belt, for example, could be used for the drive.

The winnower was designed for use with the hand-operated sunflower seed decorticators developed by TPI (*Rural Technology Guides* 9 and 10) but it can be used for a wide variety of materials.

Description

17

A general arrangement of the winnower is shown in Fig. 1. The unit is made up of three distinct components; the body, the wind case and the fan.

The winnower is operated by turning the drive handle which rotates the fan, forcing air into the wind case. Decorticated material is fed into the wind case where the lighter pieces of shell or husk are blown out and the heavier kernel falls down to be collected separately. The winnower can be operated by one person.

Figure 1
Winnower assembly

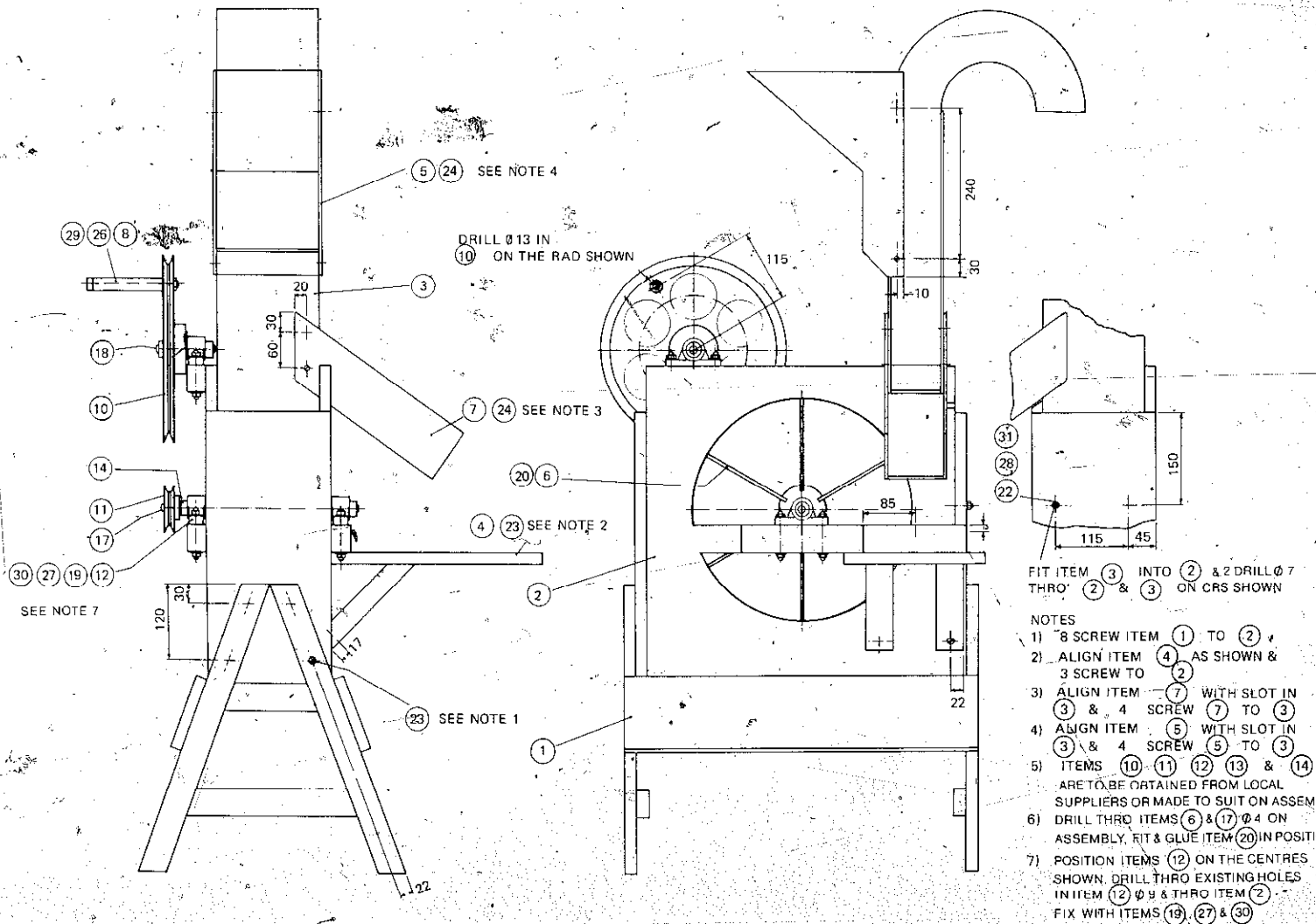

ITEM NO.	DESCRIPTION	NO. OFF	REMARKS
1	SADDLE	1	FIGURE 8
2	BODY	1	FIGURE 2
3	WIND CASE	1	FIGURE 4
4	TABLE ASSY	1	FIGURE 13
5	LARGE CHUTE	1	FIGURE 6
6	FAN	1	FIGURE 10
7	CHUTE	1	FIGURE 7
8	HANDLE	1	FIGURE 15
9			
10	PULLEY WHEEL Ø 300	1	Ø 12 BORE SINGLE GROOVE 12 SECTION
11	PULLEY WHEEL Ø 75	1	Ø 12 BORE SINGLE GROOVE 12 SECTION
12	PLAIN BEARING PILLOW BLOCK	3	Ø 12 BORE
13	BELT	1	
14	COLLAR Ø 12 BORE	4	STL 25 OD X 12 WIDE
15			
16			
17	LONG SHAFT	1	STL 12 OD STOCK X 325 LONG
18	SHORT SHAFT	1	STL 12 OD STOCK X 95 LONG
19	STUD M8	6	STL 85 LONG
20	PIN Ø 4	1	STL STOCK 75 LONG
21			
22	SCREW M6 HEX HEAD	2	STL 50 LONG
23	WOODSCREW	11	STL 32 LONG
24	WOODSCREW	8	STL 10 LONG
25			
26	NUT M12	1	STL
27	NUT M8	12	STL
28	NUT M6	2	STL
29	WASHER M12	1	STL
30	WASHER M8	12	STL
31	WASHER M6	4	STL

Manufacture

The winnower can be manufactured in a carpenter's workshop or by anyone who has carpenter's tools and the use of a lathe. The following machine tool is needed, together with a competent operator: —

- a. A small lathe for turning up the boss for the fan and drilling a hole for the spindle.

The following hand tools are required:

- b. Bench and vice.
- c. Hand-held drill—electric if possible—and twist drills.
- d. Hacksaw and fretsaw (or hole saw).
- e. Carpenter's tools such as a plane, a wood saw, chisels and a mallet.
- f. Engineering hand tools such as a hammer, tinsnips and files.
- g. Marking-out equipment.

The winnower can be manufactured mainly from local materials but the following special components are also necessary: —

- h. Three plain bearing pillow blocks (see page 3).
- i. Two pulleys (see page 20).

The materials required for the various parts are listed on page 5. All drawings are in 3rd angle projection as in British Standards 308. **All dimensions are in millimetres unless otherwise stated.**

Abbreviations

The following abbreviations have been used on drawings: — ALUM = aluminium; ASSY = assembly; CRS = centres; CSK = counter sink (or countersunk); C/BORE = counterbore; EQUI-SP = equally spaced; M/C = machine; MIN = minimum; OD = outside diameter; RAD = radius; REF = reference; SQU = square; STL = steel; TRI = triangular; TYP = typical.

Construction and assembly instructions are given in the following pages.

You are advised to read them through carefully before starting work.

If further information or explanation is required, please write to Tropical Products Institute, Industrial Development Department, Culham, Oxfordshire, UK.

Parts and materials list

All dimensions in millimetres

Part Description	Figure No	Item No	Part Details	Material	Approximate Amounts Required
Winnower body	2	1	Side panels (2)	Wood	2 off 435 × 205 × 18 Blockboard is suitable
		2	Front panel	Wood	510 × 498 × 18 Blockboard is suitable
		3	Back panel	Wood	510 × 498 × 18 Blockboard is suitable
		4	Stop	Wood	169 × 50 × 18
		5	Central mounts (2)	Wood	2 off 200 × 44 × 32
		6	End mount	Wood	150 × 44 × 32
Wind case	4	1	Drum body	Wood	1050 × 1000 × 5 plywood
		2,10,11	Covers (3)	Metal	1200 × 165 × 1: 500 × 165 × 1: 250 × 165 × 1 aluminium or other thin metal
		3	Backing strip	Wood	795 × 165 × 5 Cut from drum body left-overs
		4	Stiffener	Wood	300 × 165 × 18
		5,6	Top boards (2)	Wood	220 × 165 × 5: 205 × 165 × 5 Cut from drum body left overs
		7	Side boards (2)	Wood	2 off 565 × 320 × 5. Cut from drum body leftovers
		8	Gusset (3)	Wood	2 off 80 × 20 × 8, 1 off 165 long shaped to fit
		12	Spacers (3)	Wood	3 off 155 × 20 diameter
Saddle	8	1	Legs (4)	Wood	4 off 460 × 44 × 20
		2	Long side members (2)	Wood	2 off 375 × 44 × 20
		3	Short side members (2)	Wood	2 off 245 × 44 × 20
		4	Side rails (2)	Wood	2 off 575 × 130 × 20
Fan	10	1	Body	Wood	100 × 75 diameter
		2	Blades (8)	Wood	8 off 157 × 148 × 5 plywood
Large chute	6		Sides (2)	Wood	Cut from 325 × 325 × 5 plywood
			End	Wood	Cut from 465 × 166 × 5 plywood
Chute	7		Sides (2)	Wood	2 off 340 × 90 × 5 plywood
			Base	Wood	230 × 90 × 5 plywood
Table assembly	13	1	Table	Wood	345 × 230 × 18 Blockboard is suitable
		2	Legs (2)	Wood	2 off 190 × 44 × 32
		3	Back block	Wood	165 × 44 × 20
Drive assembly	1	10	Pulley		300 dia × 12 bore single groove 12 section
		11	Pulley		75 dia × 12 bore single groove 12 section
		12	Bearings (3)		Plain bearing pillow blocks 12 bore
		13	Belt		Sufficient to fit drive assembly
		14	Collars (3)	Metal	25 OD × 12 wide × 12 bore
		17	Long shaft	Metal	Steel rod 325 × 12 OD
		18	Short shaft	Metal	Steel rod 95 × 12 OD
		15	Handle	Metal	140 × 20 OD steel rod. 120 × 22 OD tube 0.8 wall thickness 10 × 25 OD steel rod

Winnower body

Mark out and cut to size (see Parts and materials list, page 5) the four panels, the two central mounts, the end mount and the stop (Fig. 2).

Mark and cut out the hole in the front panel, using a fretsaw or hole saw.

Drill the hole for the fan shaft in the back panel.

Screw the stop to one side panel in the correct position as shown in Fig. 2.

Drill holes to suit the position of the holes in the bearing base (Fig. 1, item ⑫) in the end mount and the central mount (Figs. 2, items ⑤ and ⑥). Then fix the mounts to the front and back panels; make sure that the bearing position on the central mounts corresponds with the position of the drilled hole in the back panel (Fig. 2, item ③).

Screw the two side panels to the back panel, but do not screw the front panel on at this stage (see fixing instructions under 'Assembly', page 20).

Note If a non-adjustable belt is to be used, do not bolt the end mount bearing into position. See fixing instructions under 'Assembly', page 20.

Figure 2
Winrower body

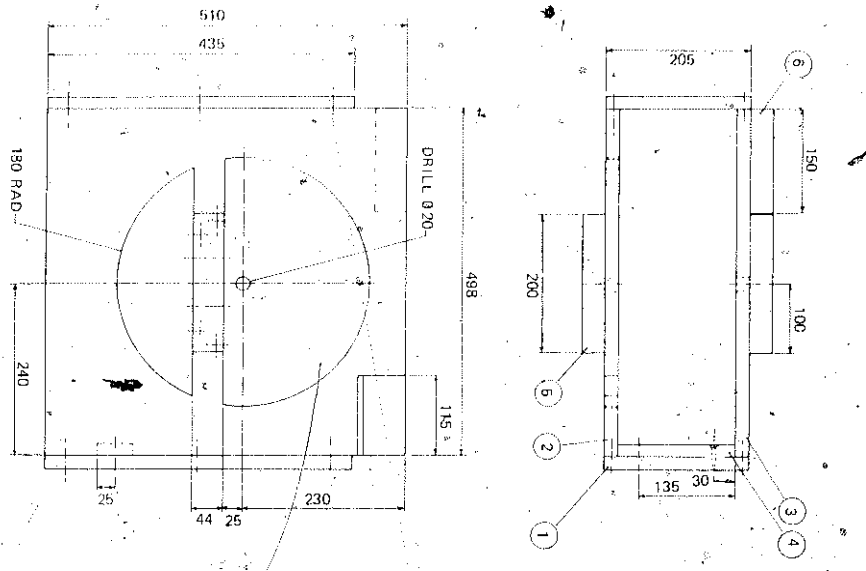

- NOTES
 1) GLUE ALL JOINTS BEFORE SCREWING
 2) ITEM (4) IS TO BE SCREWED TO (1) & (1) IS TO BE SCREWED TO (2) & (3) AS SHOWN

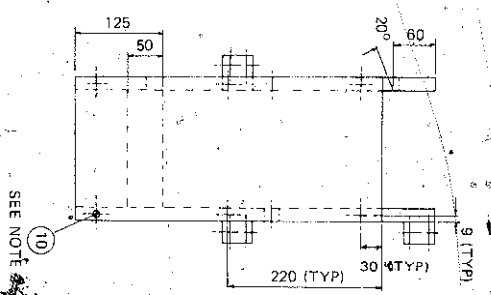
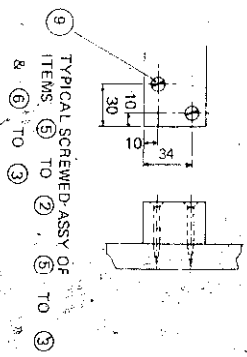

ITEM No.	DESCRIPTION	No. OFF	REMARKS
1	SIDE PANEL	2	WOOD 18 THICK
2	FRONT PANEL	1	WOOD 18 THICK
3	BACK PANEL	1	WOOD 18 THICK
4	STOP	1	WOOD 18 THICK
5	CENTRAL MOUNT	2	WOOD 32 x 44
6	END MOUNT	1	WOOD 32 x 44
7			
8			
9	WOOD SCREW	12	STL 45 LONG
10	WOOD SCREW	14	STL 30 LONG

Figure 3
Winnower body

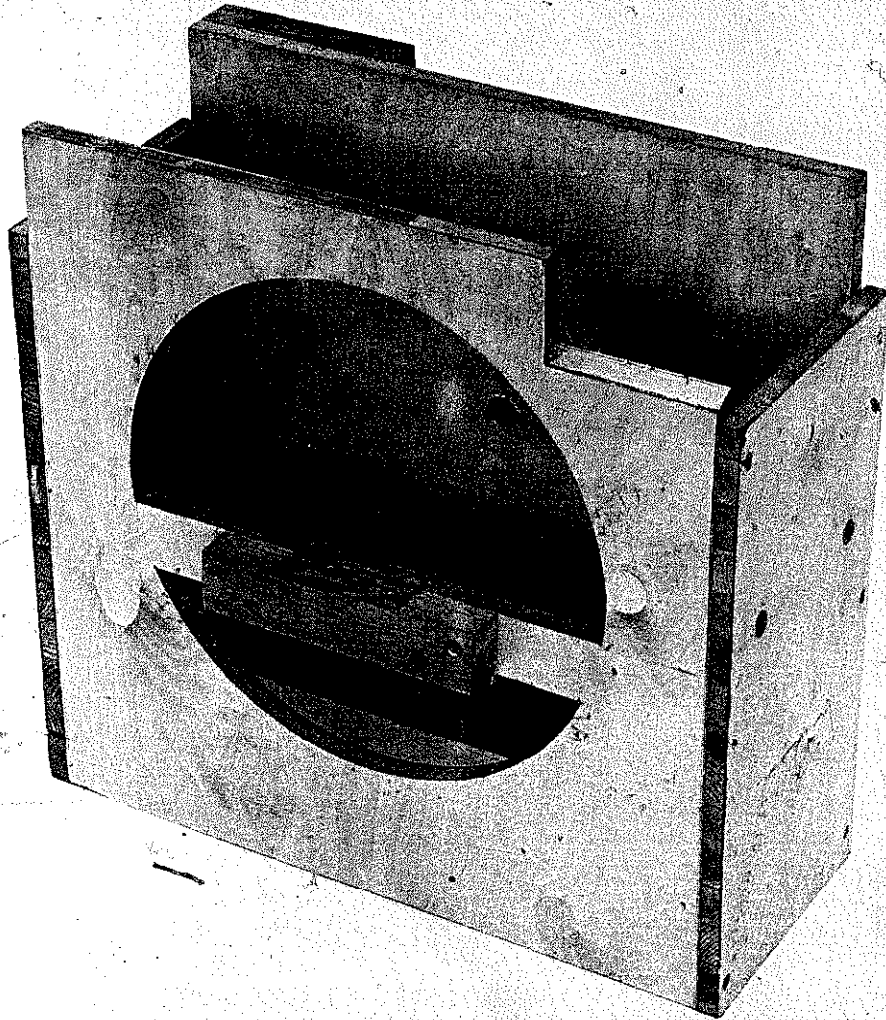

Wind case

Mark out and, with a fretsaw or hole saw, cut to size (see Parts and materials list, page 5) the two pieces of wood for the wind case drum body (Fig. 4).

Cut the three spacers to correct lengths and glue and nail one end of each of them in position on one side of the wind case drum body only at this stage.

Mark out and cut to size all the other wooden items required for the wind case.

Fix the stiffener to the backing strip, then fix the backing strip to that side of the wind case drum body to which you have nailed the spacers.

Fit the other side of the wind case drum body to the backing strip, make sure that it is in the correct position, then glue and nail all the joints including the other ends of the spacers.

Next fit the top boards and side boards with nails and glue.

Cut the three covers and drill small holes to take the fixing nails along all edges where required. Bend the covers to shape and fix them in position with nails and glue.

Finally, fit the three gussets in position and the wind case (Fig. 5) is ready to be fixed into the winnower body.

The two chutes can be made at this stage (Figs 6 and 7) but do not fix them to the wind case until it (the wind case) is assembled in the winnower body.

Figure 4
Wind case

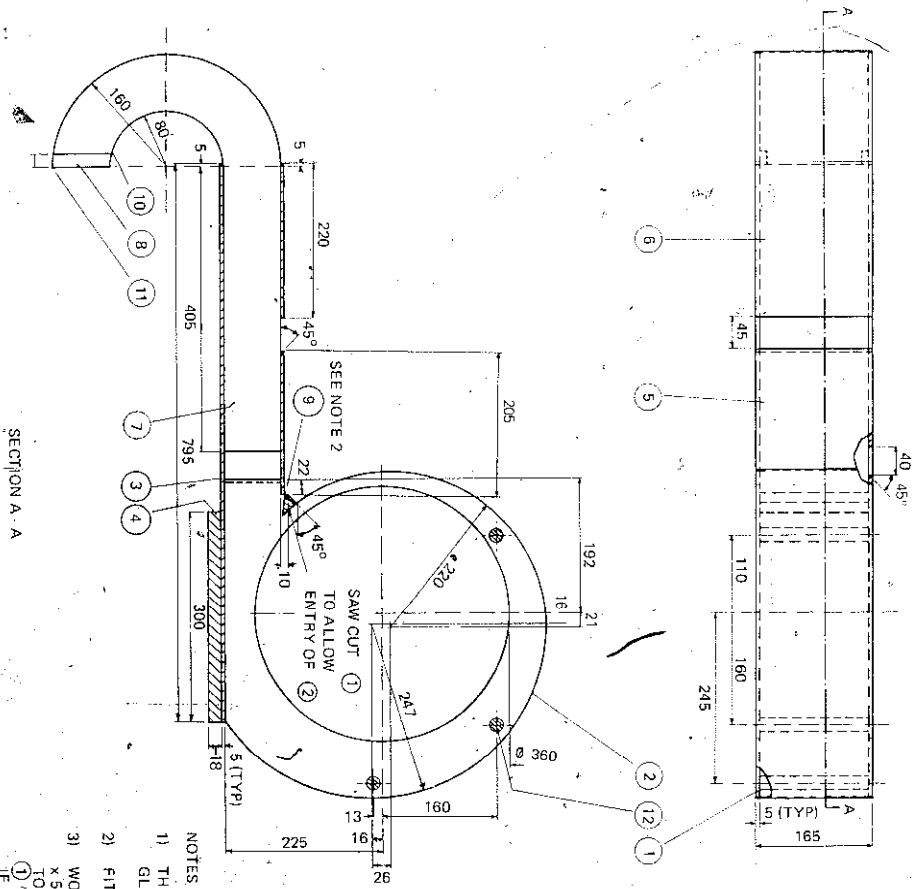

ITEM No.	DESCRIPTION	No. OFF	REMARKS
1	DRUM BODY	2	5mm THICK PLYWOOD
2	COVER	1	1mm THICK ALUM. ALLOY
3	BACKING STRIP	1	5mm THICK PLYWOOD
4	STIFFENER	1	18mm THICK PLYWOOD
5	TOP BOARD	1	5mm THICK PLYWOOD
6	TOP BOARD	1	5mm THICK PLYWOOD
7	SIDE BOARD	1	5mm THICK PLYWOOD
8	GUSSET	2	20 x 3 WOOD
9	GUSSET	1	WOOD
10	COVER	1	1mm THICK ALUM. ALLOY
11	COVER	1	1mm THICK ALUM. ALLOY
12	SPACER	3	Ø 20 WOOD

- NOTES
- 1) THIS ASSEMBLY IS TO BE GLUED & THEN NAILLED TOGETHER
 - 2) FIT ITEM ⑨ ON ASSEMBLY
 - 3) WOOD GUSSETS 20 x 20 (TR) SECTION) x 50 LONG MAY BE GLUED & NAILED TO THE CORNERS OF ITEMS ①, ③, & ⑤, ③, ⑤ & ⑦, ③, ⑥ & ⑦ IF REQUIRED.

SECTION A-A

Figure.5
Wind case

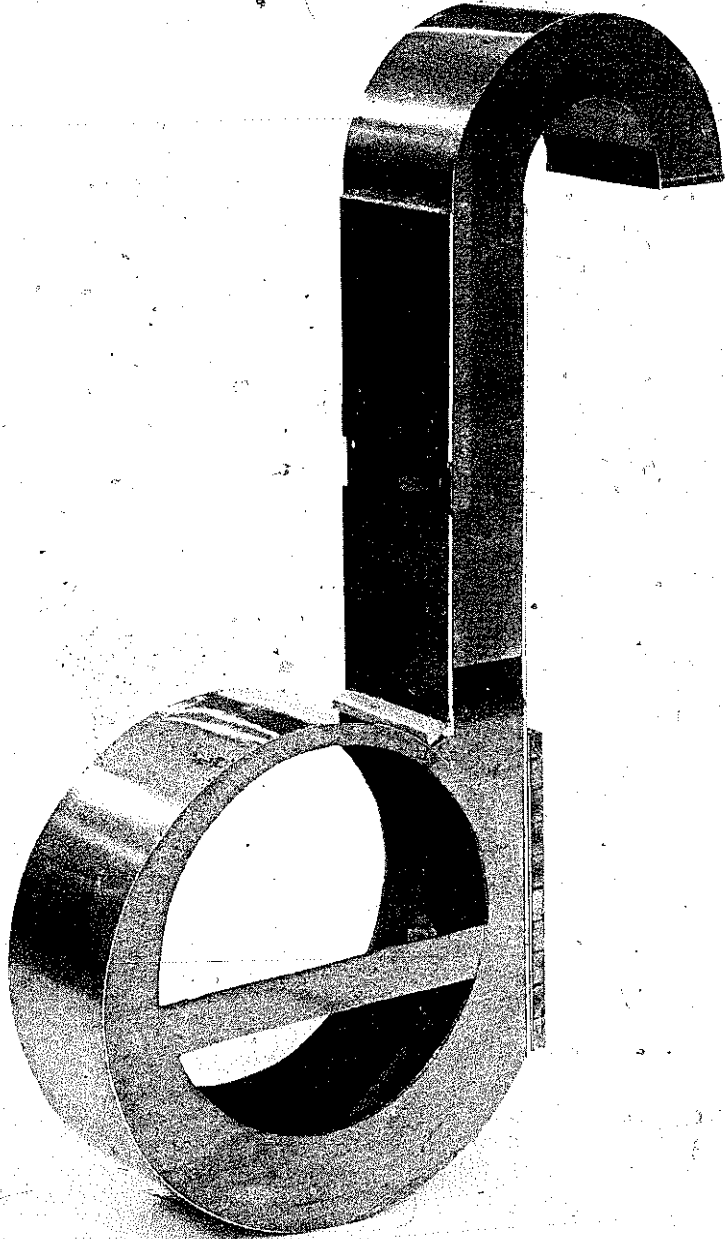

Figure 6
Large grain chute

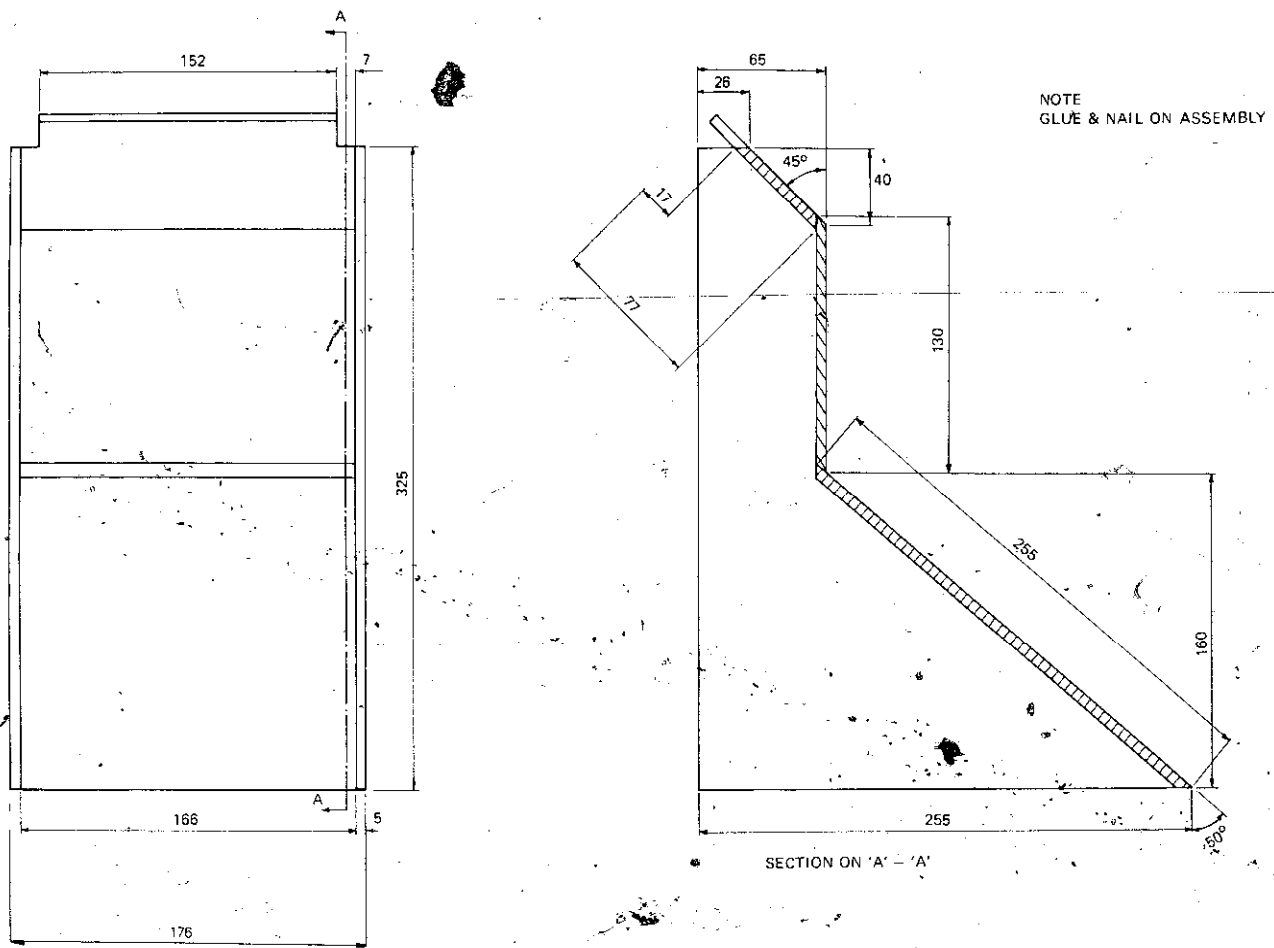
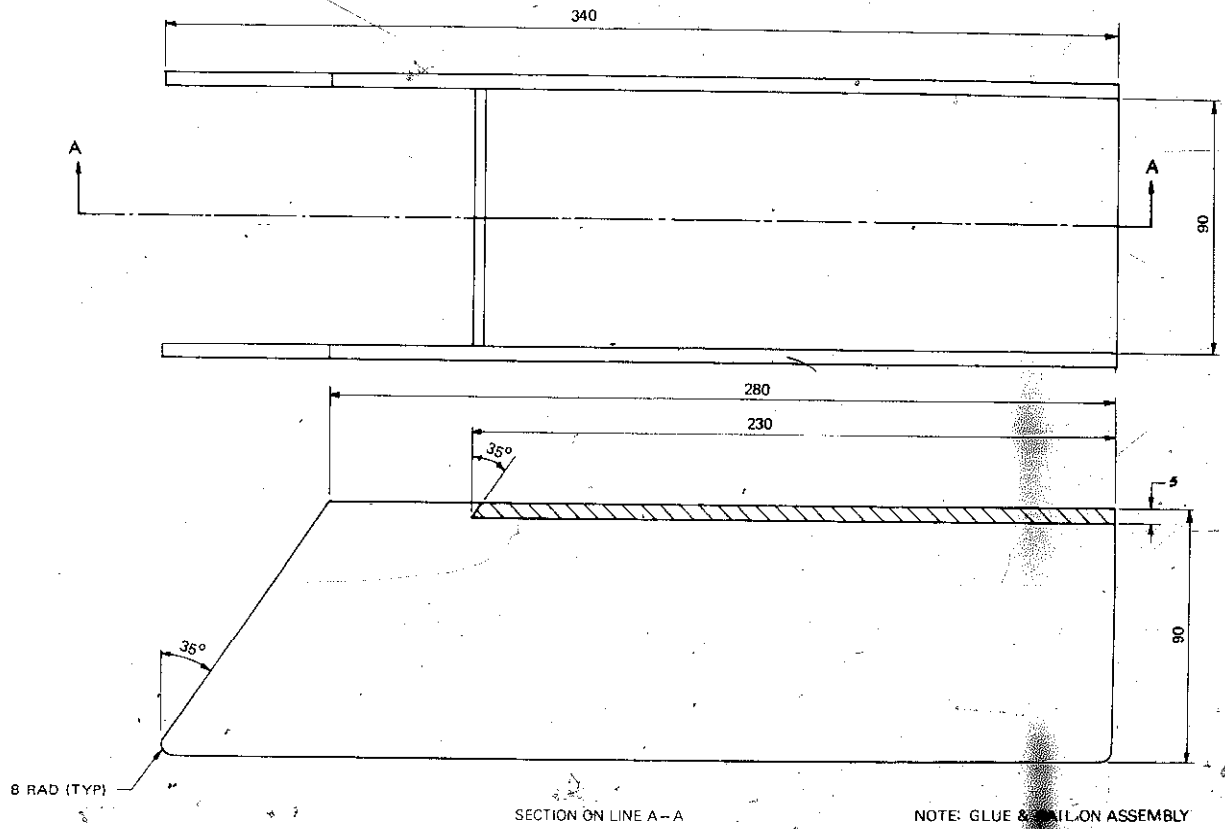

Figure 7
Chute



Saddle

Cut all pieces of wood to the correct length (see Parts and materials list, page 5).

Mark out the positions of the side members on the legs, then screw the side members to the legs, using carpenter's glue on the joints. Make sure that both pairs of legs incline at the same angle so that the saddle will stand firmly on all four legs.

Next mark out the positions of the side rail, then screw and glue them to the legs, again making sure that the saddle will stand firmly on all four legs. Check this before finally tightening the screws (Figs 8 and 9).

Figure 9
Saddle.

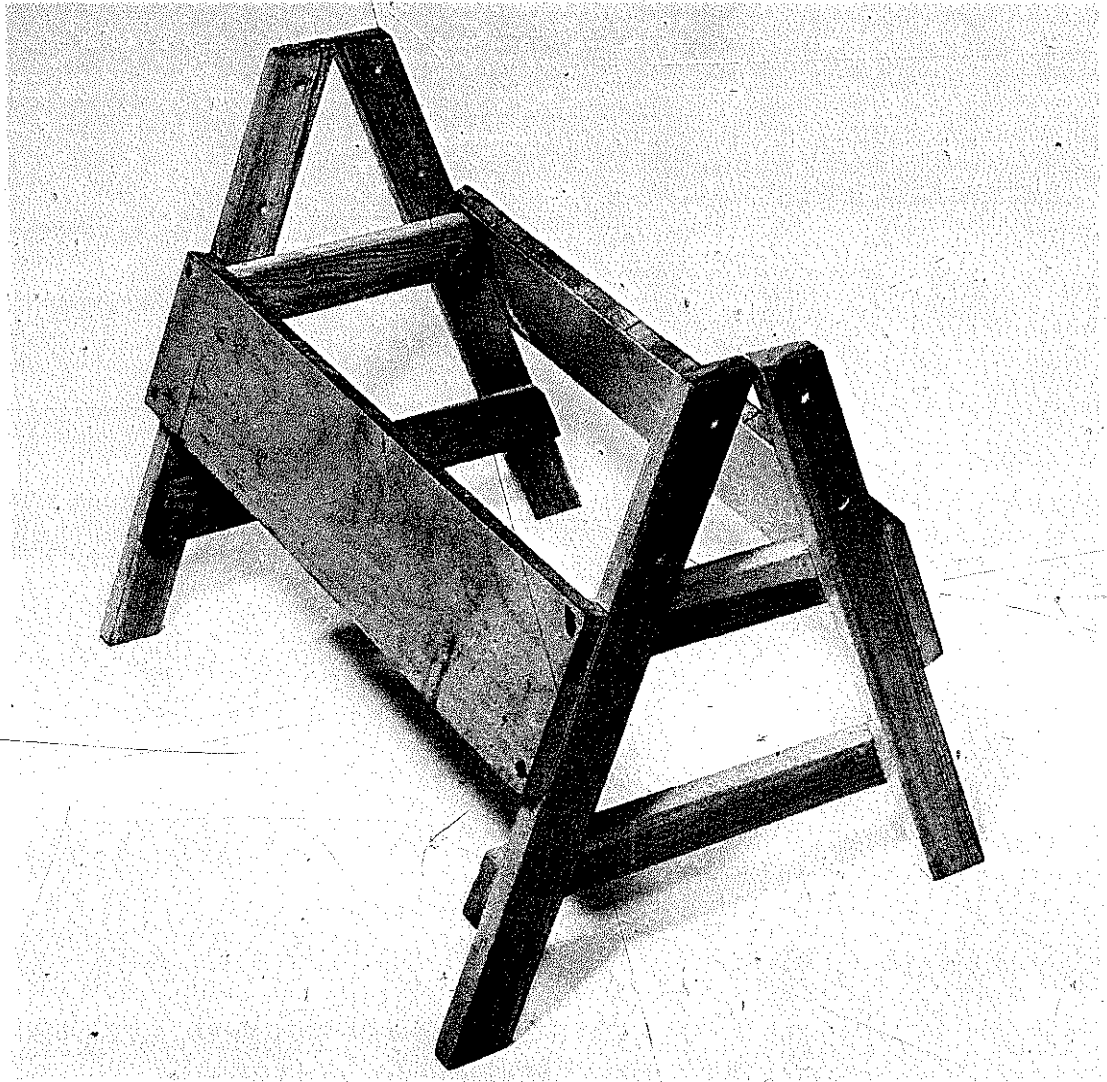

Fan

Mark out and cut to correct size the eight fan blades (see Parts and materials list, page 5).

If wood of the required diameter is not available for the fan boss, turn a piece of wood to the correct diameter in the lathe. Alternatively, the boss can be made from wood of square section by planing the four corners to make an octagon (i.e. with eight faces).

Drill the hole through the centre of the boss to take the shaft, fit the shaft through the boss in the correct position, then drill a small hole through the boss and shaft, and secure the boss to the shaft with a pin.

Mark out and cut the grooves for the fan blades and glue the blades in position (Figs 10 and 11).

Fan

Mark out and cut to correct size the eight fan blades (see Parts and materials list, page 5).

If wood of the required diameter is not available for the fan boss, turn a piece of wood to the correct diameter in the lathe. Alternatively, the boss can be made from wood of square section by planing the four corners to make an octagon (i.e. with eight faces).

Drill the hole through the centre of the boss to take the shaft, fit the shaft through the boss in the correct position, then drill a small hole through the boss and shaft, and secure the boss to the shaft with a pin.

Mark out and cut the grooves for the fan blades and glue the blades in position (Figs 10 and 11).

Figure 10
Fan

ITEM No.	DESCRIPTION	REMARKS
1	BODY	WOOD
2	BLADE	WOOD

ITEM 2 5 mm STOCK. CUT 8 SLOTS EQUI SP AS SHOWN IN 1 TO SUIT

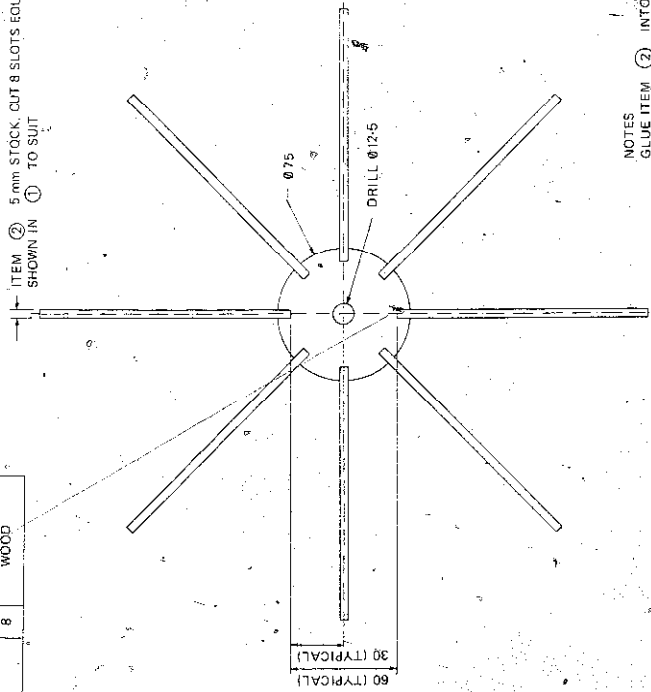
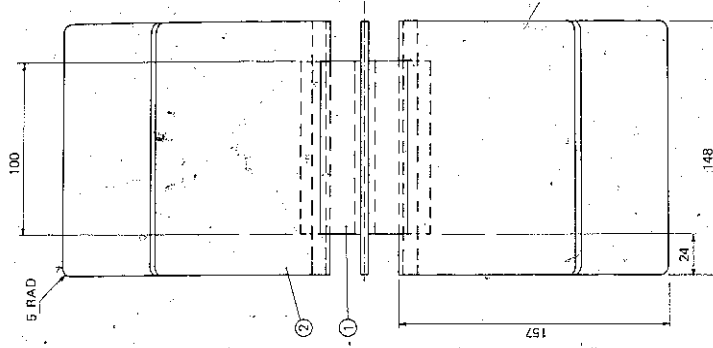

NOTES
GLUE ITEM 2 INTO 1

Figure 11
Fan

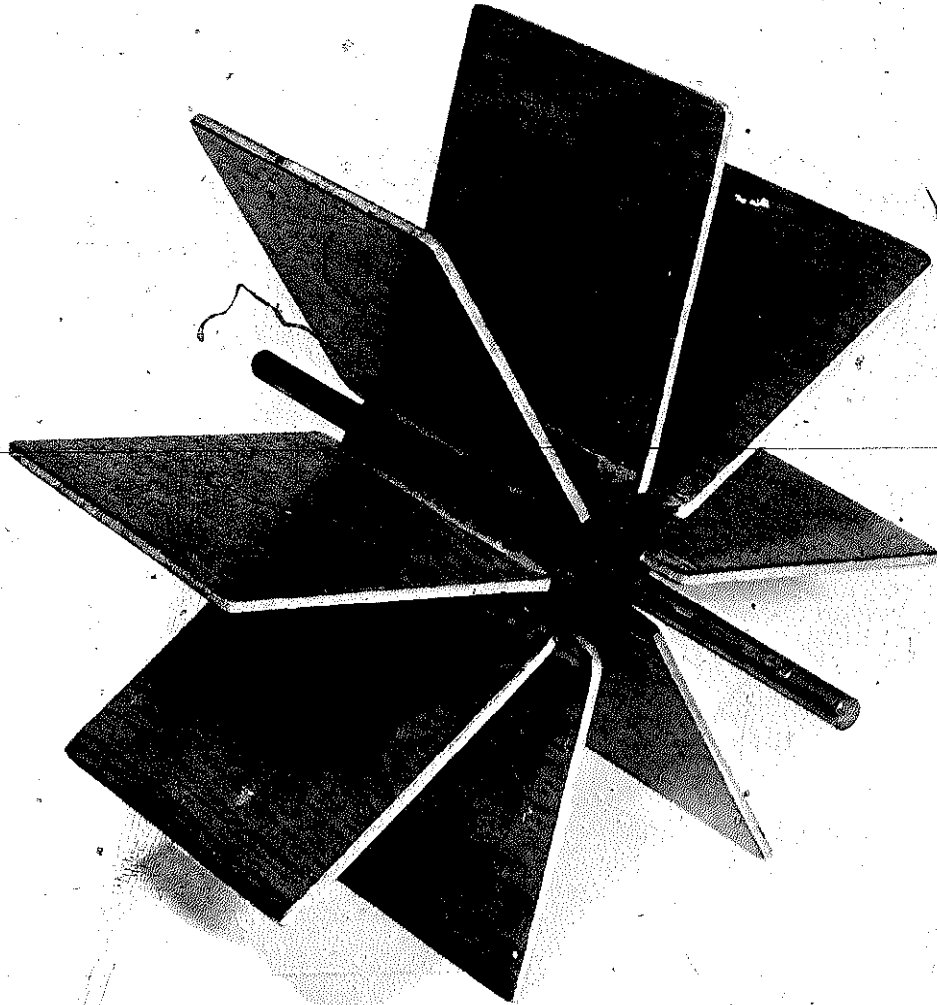

Assembly

Note Cover the hole in the front panel of the body with expanded metal or fine chicken-wire to avoid accidents (including the risk of loose clothing being drawn into the fan).

Fit the wind case into the winnower body so that the stiffener rests on the stop which is fixed to the body side panel.

Secure the wind case to the side panel with bolts and nuts.

Fit the fan into the wind case by sliding the shaft into the bearing on the back panel of the winnower body.

Insert the other end of the fan shaft into the bearings on the front panel of the body and fix the front panel to the side panels of the body.

Check that the fan will rotate freely. Some adjustment can be made by enlarging the bolt holes which secure the bearings. If the blades of the fan touch the sides of the wind case, the high spots can be removed with a wood file or sandpaper.

Fix a collar (see Parts and materials list - Drive assembly, page 5) to each end of the fan shaft.

Next fit the saddle to the winnower body.

Fit the two chutes (Figs 6 and 7, pages 12 and 13) to the wind case, then feed the wire mesh through the small slot in the side of the wind case until one end rests on the chute, then bend the other end over so that it does not fall into the wind case. Secure with small nails. Figure 12 shows the assembled chute.

Make and fit the table assembly to the winnower body (Figs 13 and 14).

Make the handle (Fig. 15) for the drive pulley and secure it in position near the rim of the pulley.

Secure the short shaft to the large pulley and insert the shaft into the bearing on the end mount. Fit and tighten the third collar on the end of the shaft.

Fit the small pulley on to the end of the fan shaft, make sure that it is in line with the large pulley, then tighten.

Fit the belt round the two pulleys. If the belt used is not adjustable do not bolt the large pulley bearing the end mount until the tension is correct. Then bolt the bearing to the end mount.

The winnower is now ready for use.

Figure 12
Assembly of chutes

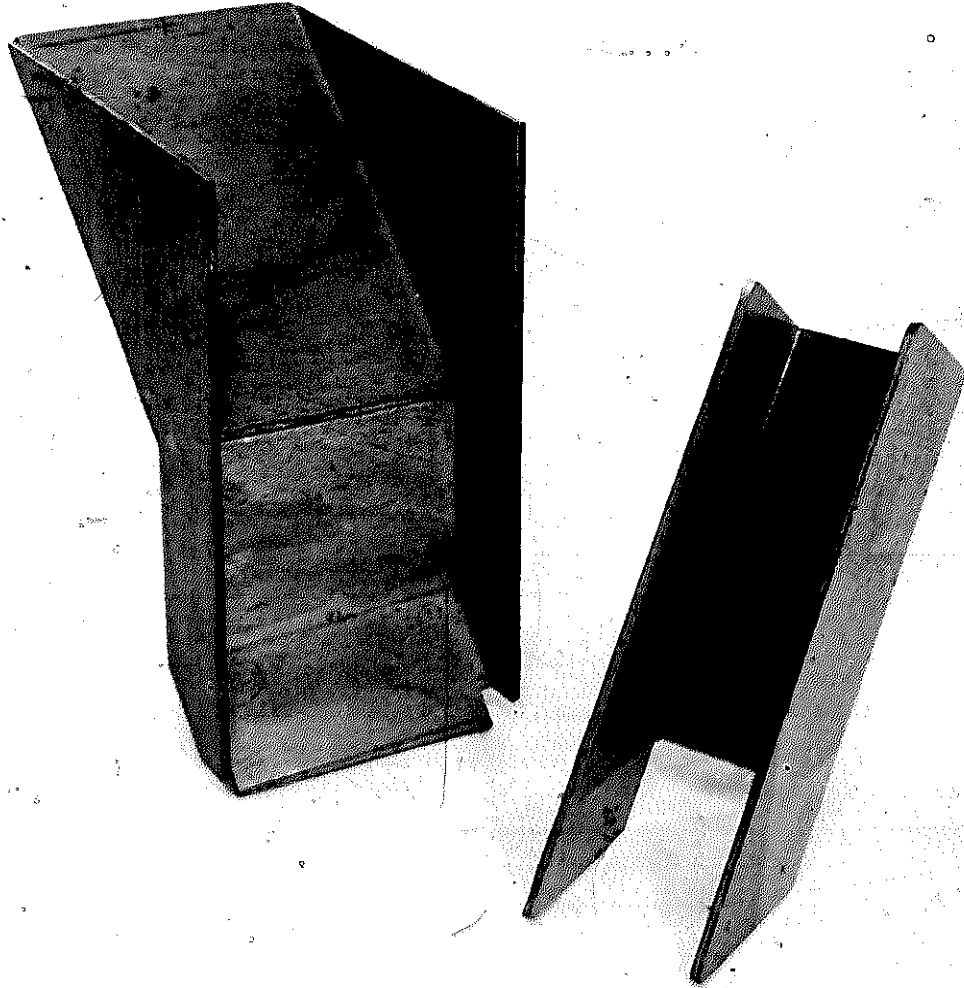
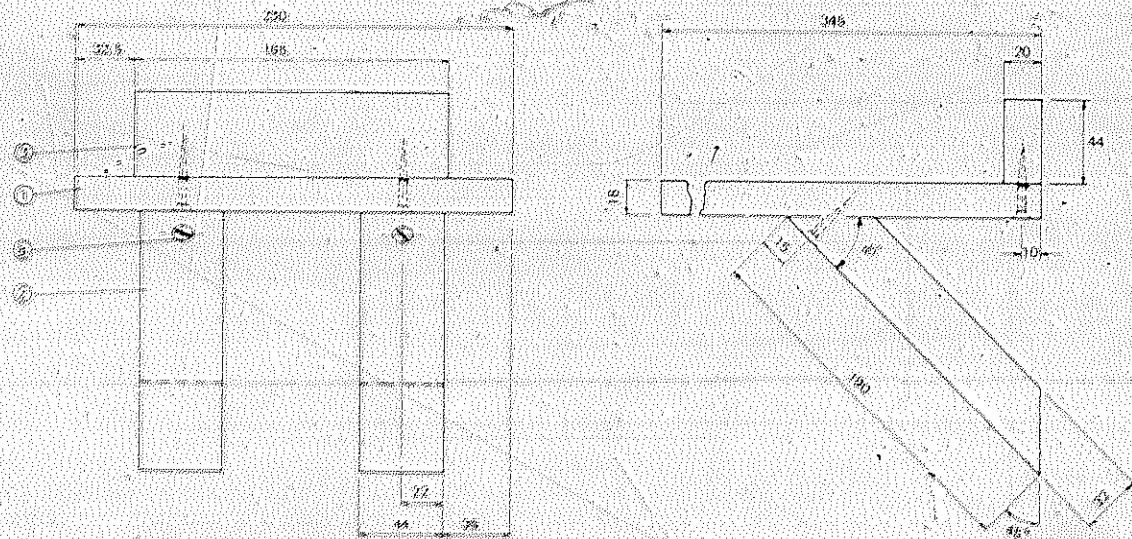

Figure 13
Table assembly



NOTE:
GLUE & THEN SCREW ON ASSEMBLY

ITEM NO.	DESCRIPTION	No. OFF.	REMARKS
1	TABLE	1	WOOD
2	LEG	2	WOOD
3	BACK BLOCK	1	WOOD
4			
5			
6	WOODSCREW	4	32 LONG STL.

Figure 14
Table assembly

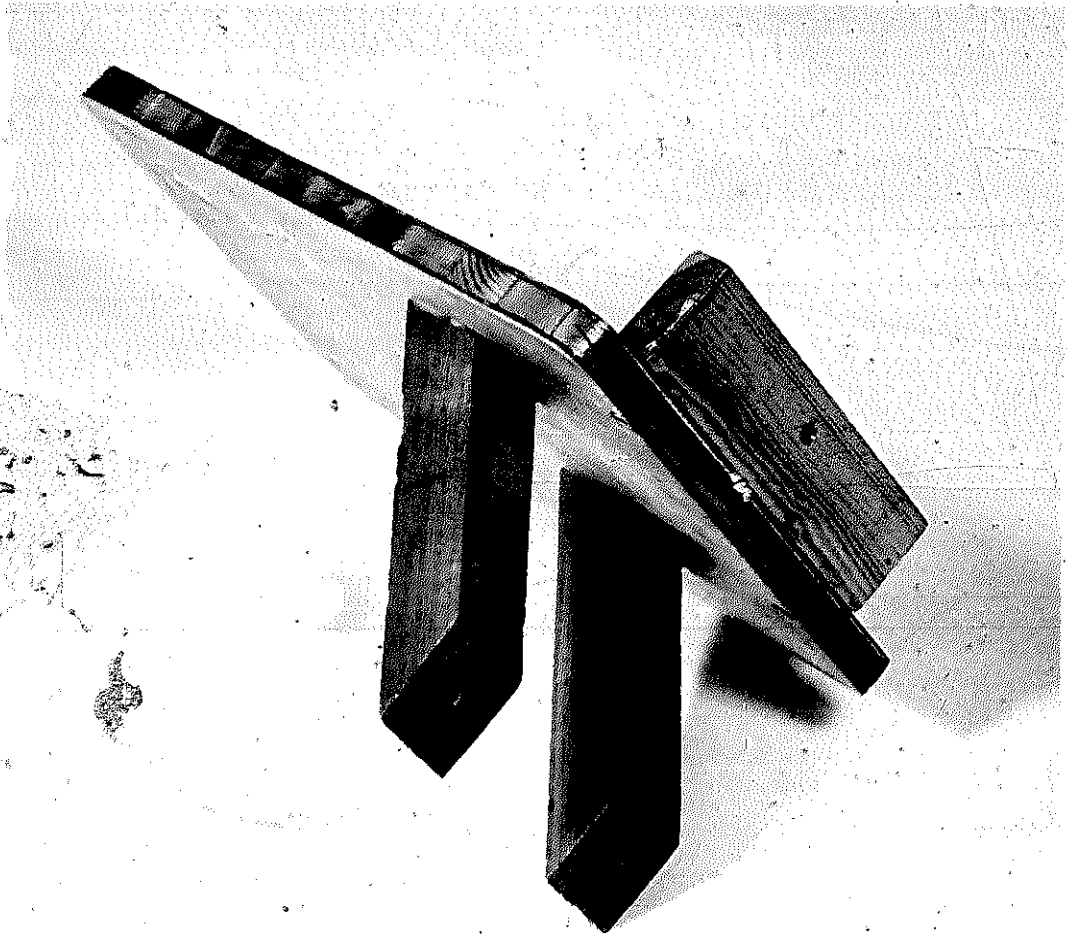

Operation

Put one container on the small table beneath the chute and another underneath the top outlet of the wind case.

Turn the pulley handle and feed the material to be winnowed into the large chute. Shell and husk will be blown from the top outlet, and kernel will fall down the chute on the side of the wind case.

The rate of feed and the speed of rotation of the fan should be determined by trial and error. For instance, when separating shell from groundnut kernels, a high fan speed can be used as the kernels are large and heavy. With smaller and lighter kernels the rate of feed and the fan speed will have to be slower. Good separation can be achieved with practice.

Before winnowing material which contains small pieces of kernel, sieve the material on a screen with an aperture of about 1 mm to remove fine kernel which could be blown away with the shell. These fines can then be added to the separated kernel.

Copyright and Reproduction Rights

The copyright of publications in this series belongs to the British Government and is © Crown Copyright 1981.

If it is intended to reproduce this guide, or any part of it, for commercial purposes, such as sale at a profit or advertising, permission must be obtained in advance from:

The Head
Publications, Publicity and Public Relations
Section
Tropical Products Institute
56/62 Cray's Inn Road
London WC1X 8LU

Otherwise, the guide, or any part of it, may be reproduced (in English or in translation) provided it includes an acknowledgement on the following lines:

Beaumont J.H. (1980). A hand-operated winnowing. *Rural Technol. Guide, Trop. Prod. Inst.*, No. 14, 28pp. Price £1.62, including packing and postage.

Copies of the guide can be purchased from the Tropical Products Institute. They are available free of charge to public bodies in countries eligible for British aid.

Future Guides

The institute would be glad to receive suggestions for new devices and techniques which might usefully be described in future publications in this series.

Tropical Products Institute

ISBN 0 85054 122-3

ISSN 0141 836X

The Tropical Products Institute

The Tropical Products Institute is a British Government organisation which co-operates with developing countries in helping them to derive greater benefit from their plant and animal resources. It specialises in problems which arise after harvest and is ready to provide information and advice on these problems if requests are addressed to:

The Director
Tropical Products Institute
56/62 Gray's Inn Road
London WC1X 8LU

Rural Technology Guides

The purpose of this series of Tropical Products Institute publications is to provide working details of devices or techniques suitable for use in rural communities. Each guide is fully illustrated and written in simple, practical language rather than in complex scientific terms, so that the reader can assess its usefulness and then, if he wishes, make the device or carry out the technique described.

The guides are intended principally for extension workers, instructors and other field staff in rural development. However, it is hoped that they will also be useful to anyone who is interested and can follow the pictures and instructions.

The series is being published in English and each publication will, therefore, be useful only in areas where the English language is widely used. For other areas, it is suggested that the text might usefully be translated into the local language and reproduced locally. It may also be possible to prepare visual aids from the pictures in the guide, for the use of instructors and other field staff.

The Institute will be pleased to give advice to anyone intending to reprint this guide or to make visual aids from the illustrations. Requests for such advice should be sent, with full details, to the Head, Publications, Publicity and Public Relations Section, Tropical Products Institute, at the above address.