

AT MICROFICHE
REFERENCE
LIBRARY

A project of Volunteers in Asia

Simple Technologies for Rural Women in Bangladesh

by: Elizabeth O'Kelly

Published by:

United Nations Children's Fund
Women's Development Unit

GPO Box 58

Dhaka-5

Bangladesh

Available from:

United Nations Children's Fund
Women's Development Unit

GPO Box 58

Dhaka-5

Bangladesh

Reproduced by permission of UNICEF/Bangladesh.

Reproduction of this microfiche document in any form is subject to the same restrictions as those of the original document.

simple technologies for rural women in bangladesh



**UNICEF, Bangladesh
Women's Development Programme**

2nd Edition

SIMPLE TECHNOLOGIES FOR RURAL WOMEN IN BANGLADESH

**By Elizabeth O'Kelly
visiting consultant.**

**Annexure no. 6 to the "Feasibility Survey of Productive/Income
Generating Activities for Women in Bangladesh" by R. Gerard.
E.O' Kelly, D. N. Saraf, Dr. J. Bunnag, M. Islam, M. Jahan.**

**UNICEF DACCA
Women's Development Programme
June 1978**

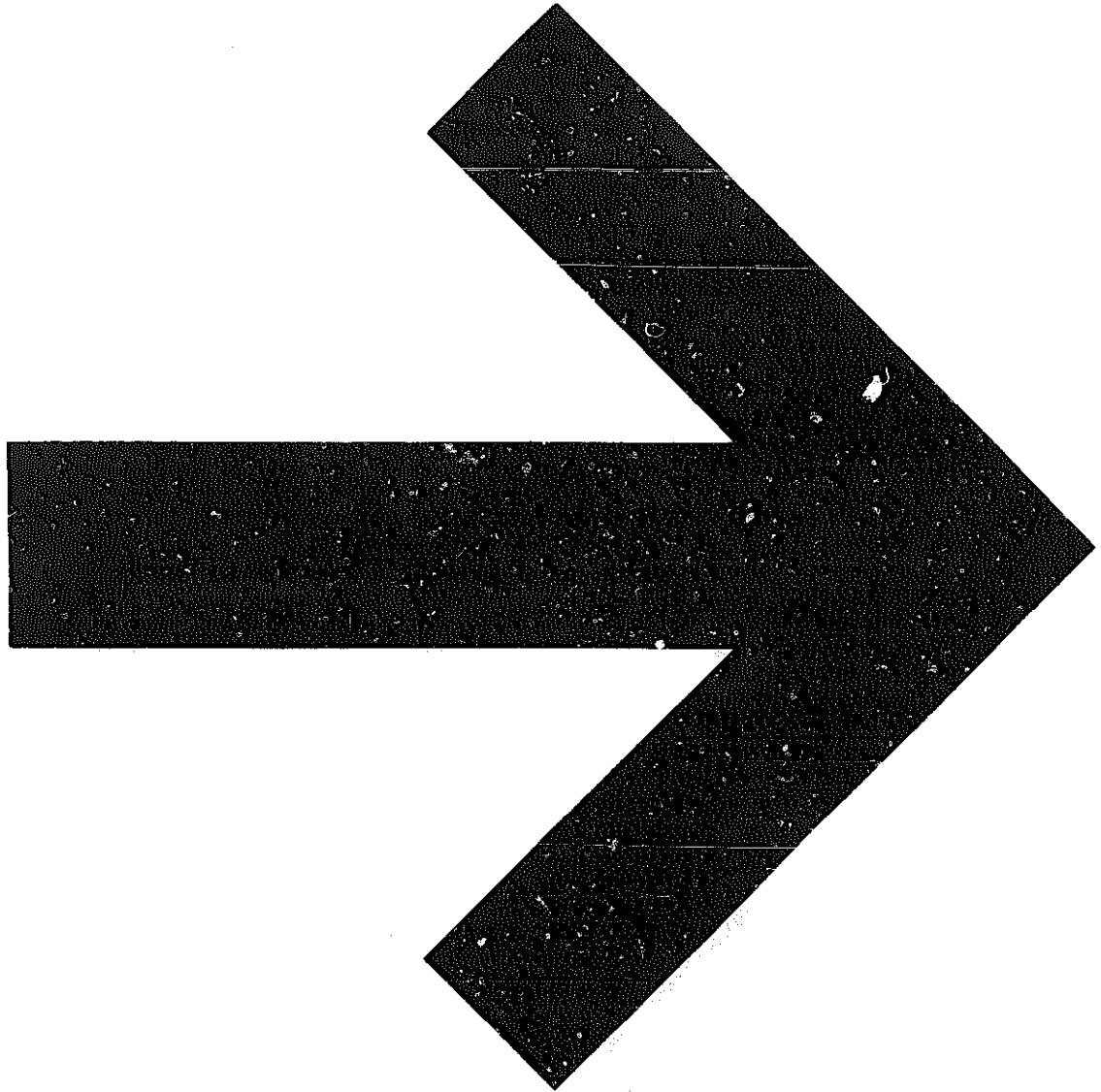

CONTENTS

| | |
|--|---------|
| • Foreword (to the second edition! by R. Gerard | |
| • Tasks of rural women | Page 1 |
| • Intermediate technology for agricultural and para agricultural activities | Page 8 |
| • Meaning of Intermediate Technology (How it could help the rural women in Bangladesh) | Page 15 |

•••

Technologies

| | |
|---------------------------|---------|
| • The Homestead | Page 23 |
| • Post harvest activities | Page 40 |
| • Water | Page 51 |
| • General | Page 59 |
| • Acknowledgement | Page 63 |
| • Manufacturers | Page 64 |
| • Manufacturer addresses | Page 66 |
| • Bibliography | Page 67 |
| • Useful addressee | Page 70 |

FOREWORD

The handbook on Simple Technologies is an annexure to a report on "Feasibility Survey of Productive/Income Generating Activities for Women in Bangladesh" which was done by a team of UNICEF staff members and outside consultants. The handbook was not meant to be used in isolation from the main report, but its very success after publication required a wider distribution than for the feasibility report. To correct this gap, the second edition of the handbook includes now three chapters from the main report. They represent the contribution of Ms. O'Kelly to the total survey. They deal with domestic tasks, agricultural and para agricultural activities of rural women, the meaning of appropriate technology and its application to Bangladesh. They explain why and how the work of rural women should be alleviated.

The handbook presents a compilation of documentation about different technologies and simple hand operated machines which can easily be made or are available for sale in developing countries. It was prepared at the request of Government officials, voluntary organisations and field workers in Bangladesh. As such the selection is most suitable for Bangladesh but it might be also useful for some other countries as a mean for circulating information about what is available and suitable for women's use. Purposely it does not indicate how to build prototypes. The underlying assumption was that they should be built locally. by local craftsmen. If possible with respect to machines which are more elaborate and are manufactured by a company the list of manufacturer's addresses is attached as annexure. The machineries for post harvesting fall into that category.

There seems to be different schools of thought with respect to appropriate technology. One is more technologically oriented and aims at producing new devices to alleviate the work and to increase production.

The **second** is concerned not only with technologies but **also** with social problems. It aims at foreseeing and measuring the social impact of introducing new **technologies**. This is the philosophy of Dr. Schumacher and our **consultants**, who follow this school of thought, viewed themselves as rural development people not as pure technologists. The **two** orientations are **complementary**, they do **not** exclude **each** other.

The handbook raised a great deal of interest and we received requests for it and comments from people working at different levels of programming for women all **over** the **world**. It was rewarding to see that **this** experiment **was** used as **an** example of what could be **done**. We welcome more comments and suggestions. In Bangladesh some organisations, on their own, produced **some** prototypes **showed** in the handbook for example the **iceless refrigerator**, and the peanut sheller.

We hope that more experimentation will be done in **different countries** with the suitable adaptations and more **exchanges** will take **place** between people concerned. **Each** region, each country, each project should assess their needs and select what is useful **for** them. We shall be happy if our undertaking is useful to many others. Our primary goal was to alleviate the burden of poor rural mothers **of Bangladesh**. It will be **all** the best if the same is achieved in other countries.

Renee Gerard
Senior **Programme** Officer
Women's Development **Programme**
UNICEF/Dacca

Dacca

June 1978

This handbook has been compiled from a number of sources as an annexure to the study of Income Generating activities for women carried out by the Women's Development Programme of UNICEF in Bangladesh in August **and** September **1977**.

It is not suggested that all the ideas shown are ones which the rural women could carry out unaided but it is hoped that the handbook will also be of use to the various organisations engaged in rural development **programmes** for women in Bangladesh.

The machines shown are all manually operated and are therefore ones which custom would permit the women to use, whilst they are sufficiently robust to stand up to collective ownership by a group of **women**. Their introduction could make an **appreciable** difference to the women's very **heavy** work load and, until this can be done, it is unlikely that the majority of them will have the time to take part in income generating or other activities -however de - **sirable** these may be.

A short bibliography , a list of suppliers and other useful addresses are at the back of the handbook as well as a list of credits.

Elizabeth O'Kelly

UNICEF, **Dacca**, Bangladesh.

1977

TASKS OF RURAL WOMEN

The Domestic tasks of the rural women:

Of the estimated population of Bangladesh, amounting to 72 million, 48% are women, whilst 91.2% of the people live in the rural areas. The following brief survey of the activities of the women therefore concentrates on the rural women and in particular the farming women since they are the ones who carry the heaviest load. It is improbable that they will be able to take part in income generating activities until this has been lightened.

The home:

Village home generally take the form of a square shaped, central compound round which the houses are built, facing inwards, one on each side of the compound and occupied by the grandparents, their children and their children's children or by other close relatives.

The house, on the side where the road is, will have another compound in front of it, less private than the inside one and will be used by the men. The women will carry out their tasks in the central compound and will also have a space at the back of the house reserved for their exclusive use.

The houses themselves are usually single storey and often of one room only although this may be partitioned into a living room and a bedroom. Some have a verandah which will be used by the men.

The walls will be made of mud and bamboo and the roofs thatched with grass although better off villagers may use burnt bricks and some may even have zinc roofs.

If there is a verandah this will have wooden cots on it to be used as seats, tobacco and a hookah will be kept here and an earthen pot with fire in it: the school children will do their studies here. Around the corner, fishing traps, agricultural tools, etc., will be piled up and seasonal articles will be stored away in the ceiling.

Inside on the wall or suspended from the roof, there will be many different types of hangers (Shikas) made of jute or bamboo to hold household articles and a large wooden box for keeping things that are regarded as valuable.

Some members of the family may sleep in cots, others on the floor, they will not use mosquito nets but they will light slow burning bundles of jute hung on a rope to keep the mosquitos away. An earthen pot filled with lighted paddy husks will be kept alive all night. Much of the interior of house will be filled with stored grain and dried foods.

In the process of digging out the clay to make the houses, a pit will have been formed which will have filled up with rain water and, in this, the women will bathe. If it dries up they will go to a larger pond with the women, usually at mid-day when the men are away in the fields. This may have a bamboo screen for privacy.

There is very seldom a latrine, and hygiene is minimal, most people will just go out into the fields to relieve themselves so that worm infestations are common, especially amongst the children

The Kitchen:

Sometimes this is just a roof supported on four poles, sometimes the women has only the verandah on which to cook, or a corner of the house itself: for six months or more, before the rains come, she may cook outside.

The stove (chula) may be sunk in the ground but more usually it is raised up and is made of mud with two holes in it to take the cooking pots. The woman may also make a smaller stove, of mud re-inforced with bamboo, which is portable, which she will take to the site of any special activity, or place it so that she can work in the shade.

Since the floor is made of mud it cannot be washed, but the women will spread a thin layer of new mud over it very frequently to renew the surface.

Shelves may be made by suspending a plank or bamboo horizontally from ropes hung from the ceiling, or they may be built up out of mud.

One corner of the room will be filled with her cooking pots, another with her winnowing trays and baskets, and pots - containing spices and dry foods will be hanging from the ceiling away from rats and cockroaches.



Making a portable chula (cooking stove)



Inside a kitchen, showing
2 chulas made of mud



A typical village home with walls made of
bamboo sticks and a thatched roof of rice straw



The compound

She will seldom have a light so that all activities will cease at night. If she must have one, because she has not finished her work, she will pour a little kerosine into a small tin and put a piece of string in this to act as a wick, hurricane lamps are too expensive for most of the villagers to be able to afford them.

There will rarely be a soak-away for dirty water, this will just be thrown on the ground outside, as will be the garbage. The result of this will be a great deal of intestinal and fly borne disease especially amongst the children and an unpleasant smell. It would deserve consideration for rural sanitation.

Tasks in the home:

Firewood is very scarce in Bangladesh so the woman will have to collect fuel of all kinds including dung, which she will dry and make into pats for burning. Strangely the women take a pride in this and often embellish the pats with design.

A woman must rise very early in the morning to prepare a meal for her husband before he goes out to the fields, she will then cook for her children and, finally, eat herself. The meal will usually consist of left over rice, curry or cooked or salted rice paste; or rice and pulses cooked together. In some districts, in winter time, they will eat sweet potatoes.

She will then send the children to school or out to keep a watch on the cows or goats whilst they are grazing and will clean out the cow and poultry sheds.

At noon she must prepare another and more substantial meal and send it out to her husband in the field if necessary. This will again consist of rice or vegetable curry, pulses, fried greens, sour soup, and occasionally, when the family can afford this, dried fish or meat curry. In the evening she must prepare a third meal consisting of the same items, she herself will eat only when the others have finished.

She must milk the animals and feed them on rice fodder mixed with gruel, mustard cakes, pulses, husks or grass brought from the fields: water hyacinths are also used, but only in limited quantity; they contain a large quantity of water and too much is bad for the cattle. She must carry water for the animals and for the family's needs.

She must also put in long hours in her kitchen garden, where she grows the fruits and vegetables for family consumption. Cows are kept for use as draught animals as well as for the milk they give and they are a status symbol in the village.

She will also wash the clothes for her family, usually carrying them down to the river or to the village pump, using soda and sometimes ashes to get them clean and rubbing them on a stone or wooden plank and she will make soap from ashes and plantain leaves.

Food preparation in the home*

The women will sometimes make paddy into beaten rice (chira) puffed rice (muri) and fried rice (khoi) both for home consumption, as a delicacy, and for sale. This and the sale of surplus fruit and vegetable and eggs, are usually the only means by which she can make a little money at present.

a) Muri is made by boiling the paddy and then soaking it overnight and boiling it again in the morning. It is then dried in the sun. Muri making is a special skill known only to some women, it requires quick action on the part of two of them working together. The specially treated paddy is next husked and the rice thus produced is roasted brown on the chula and constantly stirred with a bunch of small twigs tied together. This rice is then quickly transferred to another pot containing heated sand so that the rice puffs up quickly, this takes only a minute or two. It is then kept in tightly sealed containers.

b) Khoi is prepared from a special variety of fine paddy. It is not boiled first but is placed on heated sand in an earthen pot until it is puffed. It is then removed and the paddy husks cleaned from it.

c) Chira requires a special skill in processing the paddy. It is boiled in hot water and the women bites the grain to see when it is sufficiently tender, it is then strained into a basket but it is not dried. The paddy is then roasted in a pot until it has burst and then two women quickly crush the treated paddy in a dheki so that it is flaked.



Preparing food for the family

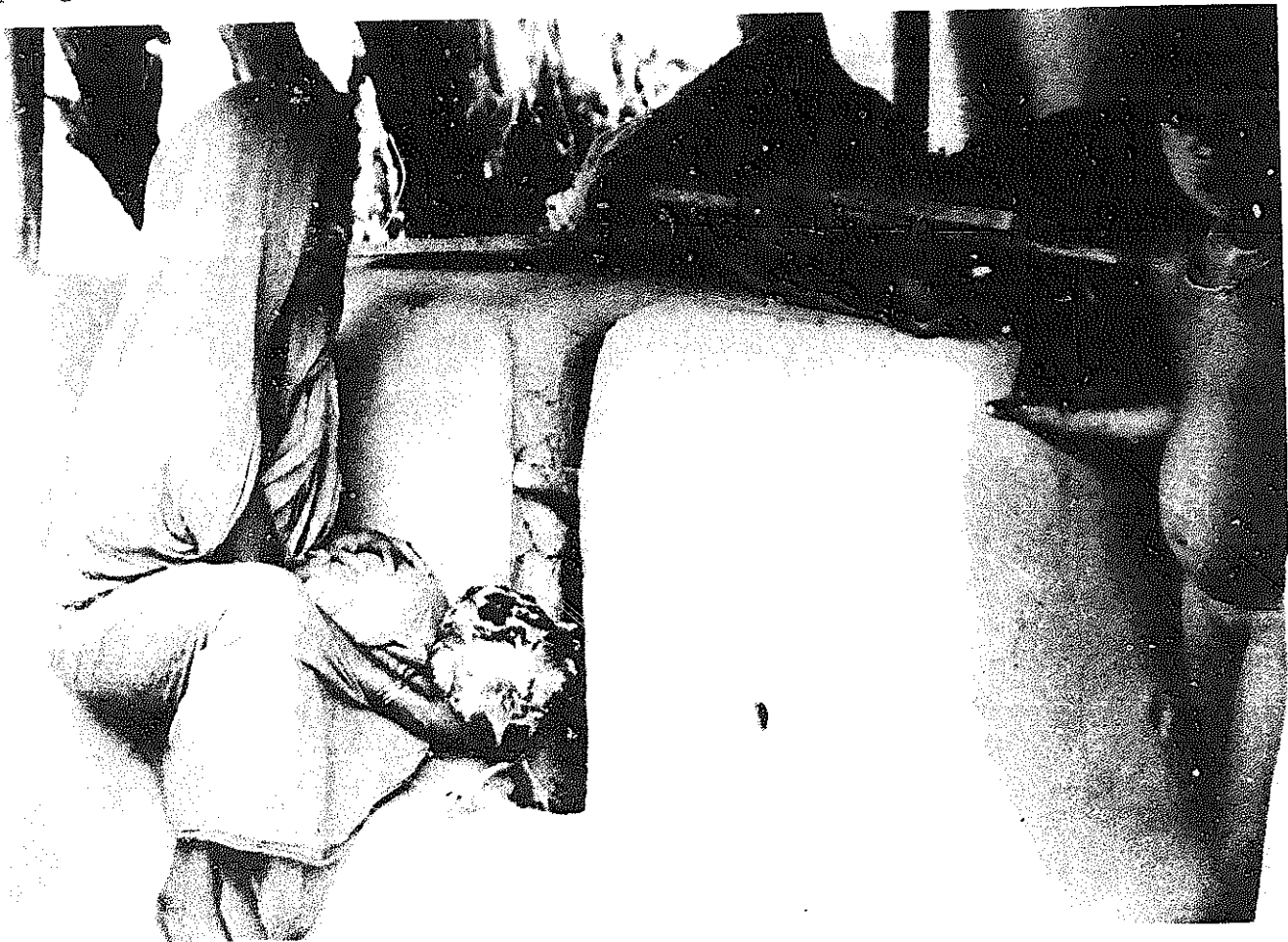

The Hen House

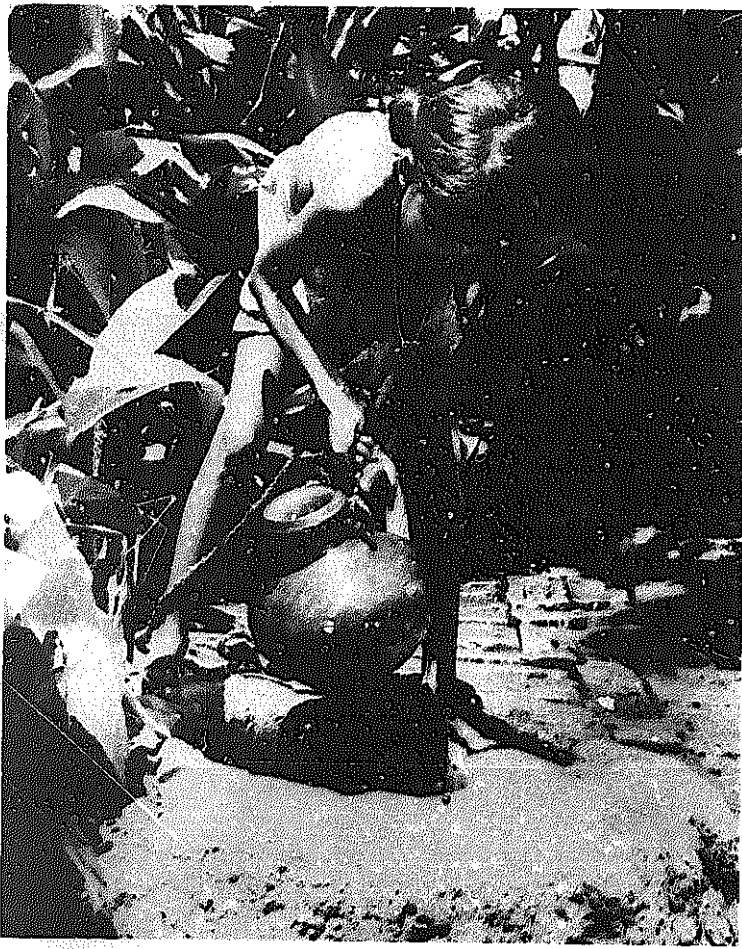

Drawing water at the family well

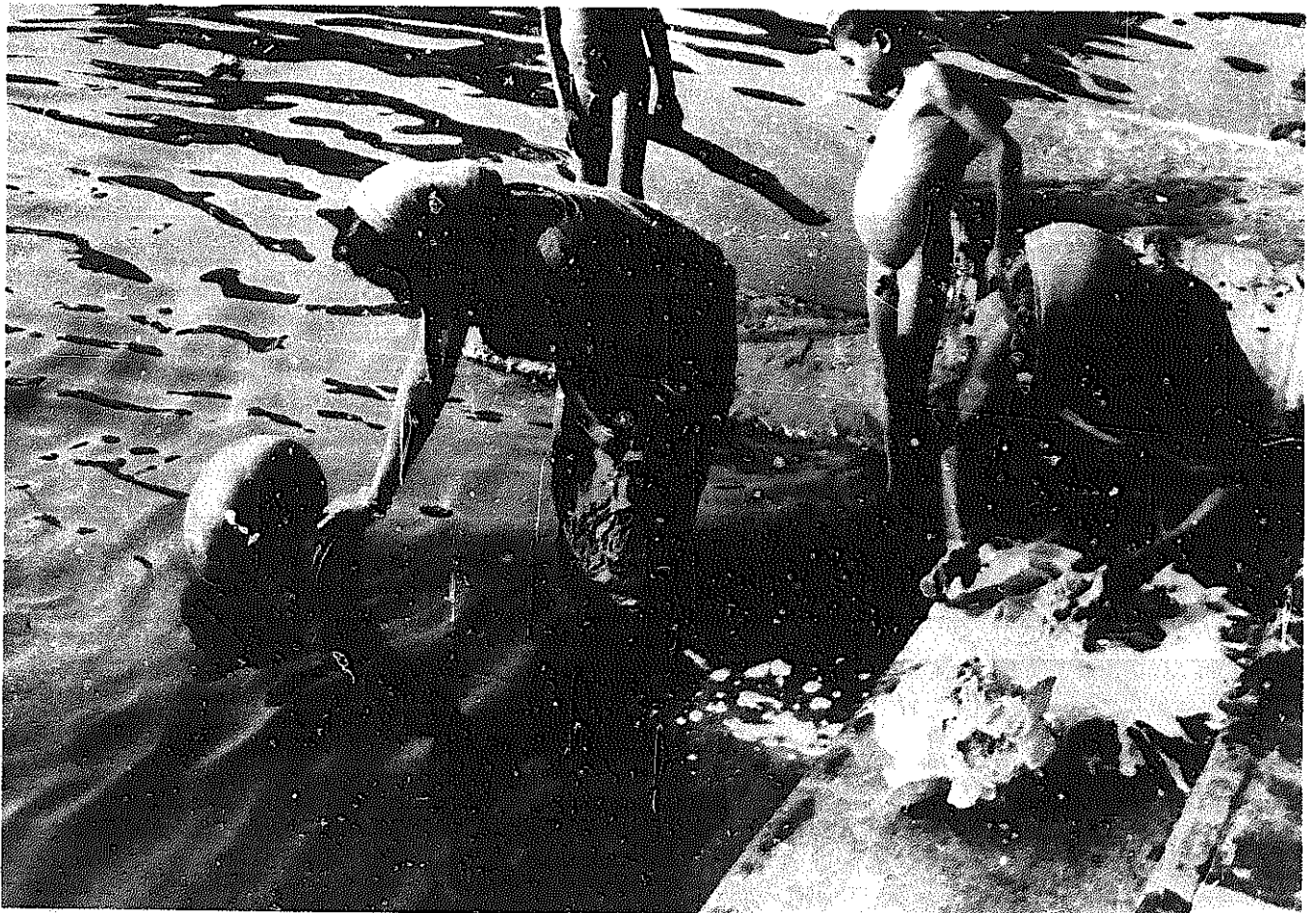

Washing clothes

Muri, Khai and Chira are made up into balls with molasses, some women do it professionally and are known as muriwali. These women take their products themselves to the local market but the other women, who do not customarily go there, must ask their husbands or children to do this for them and will only send the little which they do not consume at home.

d) Powdered rice: A woman will always keep a stock of powdered rice for preparing pithas (country cakes). She will soak the rice overnight and then powder it in a dekhi. The cakes can be dried in the sun and kept for future use.

There are also many sweets made of milk products.

Food preservation:

Drying: Women will dry green mango skins for future use in curry or sour soup and preserve ripe mangoes as achar or chutney with oil, sugar or molasses, and local spices. They will make vinegar from black berries and date juice, and molasses from crushing and then boiling cane sugar, or by tapping the juice of a date palm tree. These molasses are then kept in tightly sealed bottles or earthen pitchers which are put in jute hangers and hung in a dark corner. Ginger, onion and garlic are dried in the sun and spread out on a mat under the bed, potatoes and jack fruit, dried and spread on sand in a corner, tumeric and chillies are also dried and put in containers with tight fitting lids. Spices used in cooking are always freshly ground each day and this is another consuming tasks.

Crafts:

Many of the traditional skills the woman has, will have been handed down to her from her mother. During the monsoon season, when she cannot work outside a great deal, or, during the day time, whenever she has freedom from her multitudinous tasks, she will make:

- Red quilts and mats
- Ropes, brooms and hangers (sikas), made from jute, grass or straw or coconut fibres.
- Pitcher stands, lamp stands, stools and other articles from bamboo.
- Baskets, winnowers, sieves etc. from bamboo also

These will be for the family's use but, in some areas with a tradition of handicrafts, she will make these for sale also.

She will decorate her hone, and her pots, winnowers, tin trunks etc. with her own designs, making her colours from local herbs and using fish scales, coconuts shells, beads, buttons and palm leaves for embellishment. She will make necklaces, embroider mats and clothes and make small clay figures of people, animals and birds, which she will paint in bright colours.

Different regions have different skills, the women of the Hill Tracts especially are famous for their handicrafts.

Activities of the landless women:

The very poorest women in a village whose husbands do not own land on which they can grow their own vegetables and who may live only in small huts which they have built themselves, do not of course, undertake all the above activities. They are sometimes widows or divorced and without family of their own. They will hire themselves out as labourers to the larger landowners, during the farming season, but, for the rest of the year, they must work as servants to the other villagers or undertake any other work they can find to obtain their food. They are often reduced to begging in the monsoon season when there is no work for them and these are the women in greatest need of help now in the way of income generating activities.

They are the ones who appear to be the least involved in the current programmes for rural women, perhaps because of the educational and social gap between them and the other, better off, women in the village.

Special areas of activities:

There are certain villages where both men and women are engaged in the same works and these are named after the professions which they follow such as "Telepara" (oil crushing) "Jalepara" (fishing) "Dhopepara" (washerman's village) "Kunarpa" (potter's village) "Tatipara" (Weaver's village). Agriculture is less importance in these villages and the women play an equal part with the men in these occupations although they will still keep poultry and grow vegetables.

A Rural Women's Timetable

- 5 O'clock Rising, washing and cleaning the house and compound, releasing the poultry, collecting eggs.
- 6 - 7 a.m. Preparing the early morning meal for the working members of the family before they go out to the fields.
- 7 - 8 a.m. Milking, collecting fuel, making dung cakes, tending kitchen garden, cleaning cowshed and compound, drying straw to burn it.
- 8 - 9 a.m. Preparing food for the mid day meal, grinding species, peeling vegetables.
- 9 - 11 a.m. Husking paddy, winnowing and sifting, preparing rice products.
- 11-12 a.m. Cooking.
- 12 - 1 p.m. Washing clothes, bathing, fetching water, feeding the animals and the poultry.
- 1 - 2 p.m. Drying jute and paddy, putting other stores out in the sun to dry.
- 2 - 3 p.m. Feeding her husband and family, after this eating herself.
- 3 - 4 p.m. Making articles such as baskets and quilts for home use or for sale.
- 4 - 5 p.m. Preparing and cooking the evening meal.
- 5 - 6 p.m. Praying, bringing the children home, shutting up the poultry and animals.
- 6 - 7 p.m.. Eating the evening meal and cleaning up.
- 7 - 8 p.m. Rest period, sitting on the verandah talking and smoking before going to bed.

INTERMEDIATE TECHNOLOGY
FOR
AGRICULTURAL AND PARA AGRICULTURAL ACTIVITIES

Agricultural and Para-Agricultural
activities of the Rural Women.

Except in the Hill Tracts, or in the case of the very poorest, landless women, who hire themselves out to work as labourers, women do not usually work in the field in Bangladesh, it is against tradition. As it is also part of their way of life to make themselves as inconspicuous as possible when carrying out the many tasks they are called on to perform, the extent to which they participate in some forms of agricultural activity is often overlooked.

They are, however, responsible for the following tasks:

The preparation of the threshing floors:

The women collect suitable clay for this during the winter and keep it in a corner of their compounds. Before threshing, this inner compound is levelled, sloping from the centre outwards. The clay is soaked overnight and mixed with fresh cow dung the next morning and then spread over the compound by means of a piece of old gunny sack or netting, working from the centre to the sides. It is left to dry in the sun and the same process repeated the next day. If there is a lot of paddy, sometimes the outer compound has also to be treated in this way.

The threshing:

The actual threshing is carried out by men who usually use bullocks to trample the grain having first muzzled them, but once this has been completed the work is carried on by both men and women. The straw and grain are separated by a riddle and the grain heaped in a corner of the compound and covered with a mat. If pedal operated threshers are used, these are also usually operated by the men.

Drying the grain on a drying floor



Drying the grain on the roadway



Preparing molasses in the tray on top
of the dhala

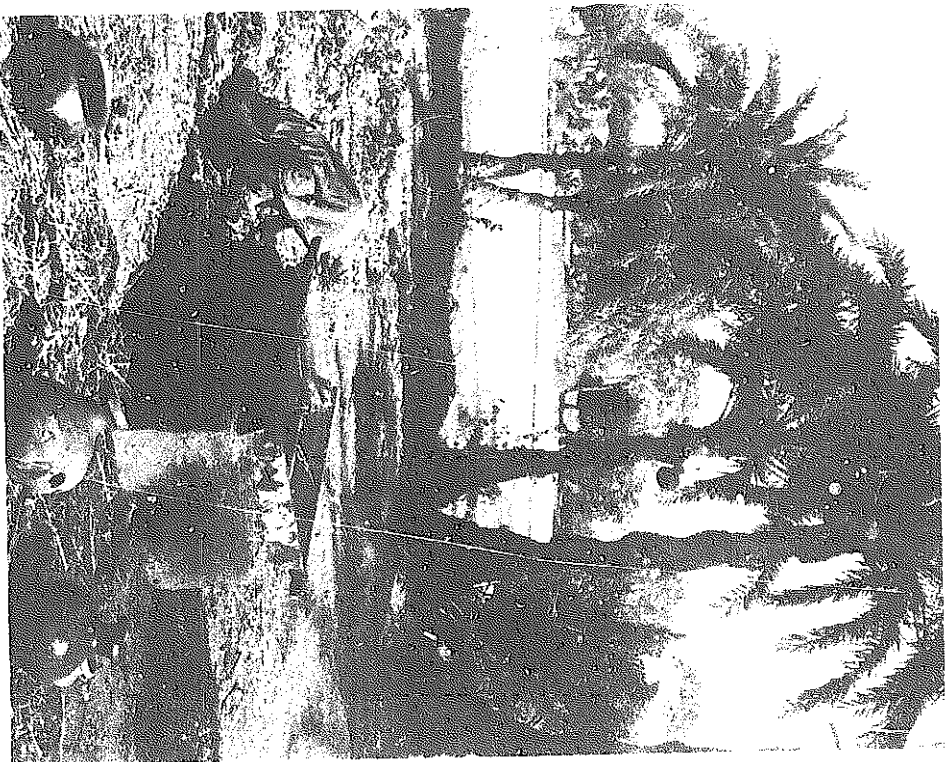

Puffing rice (dhol)

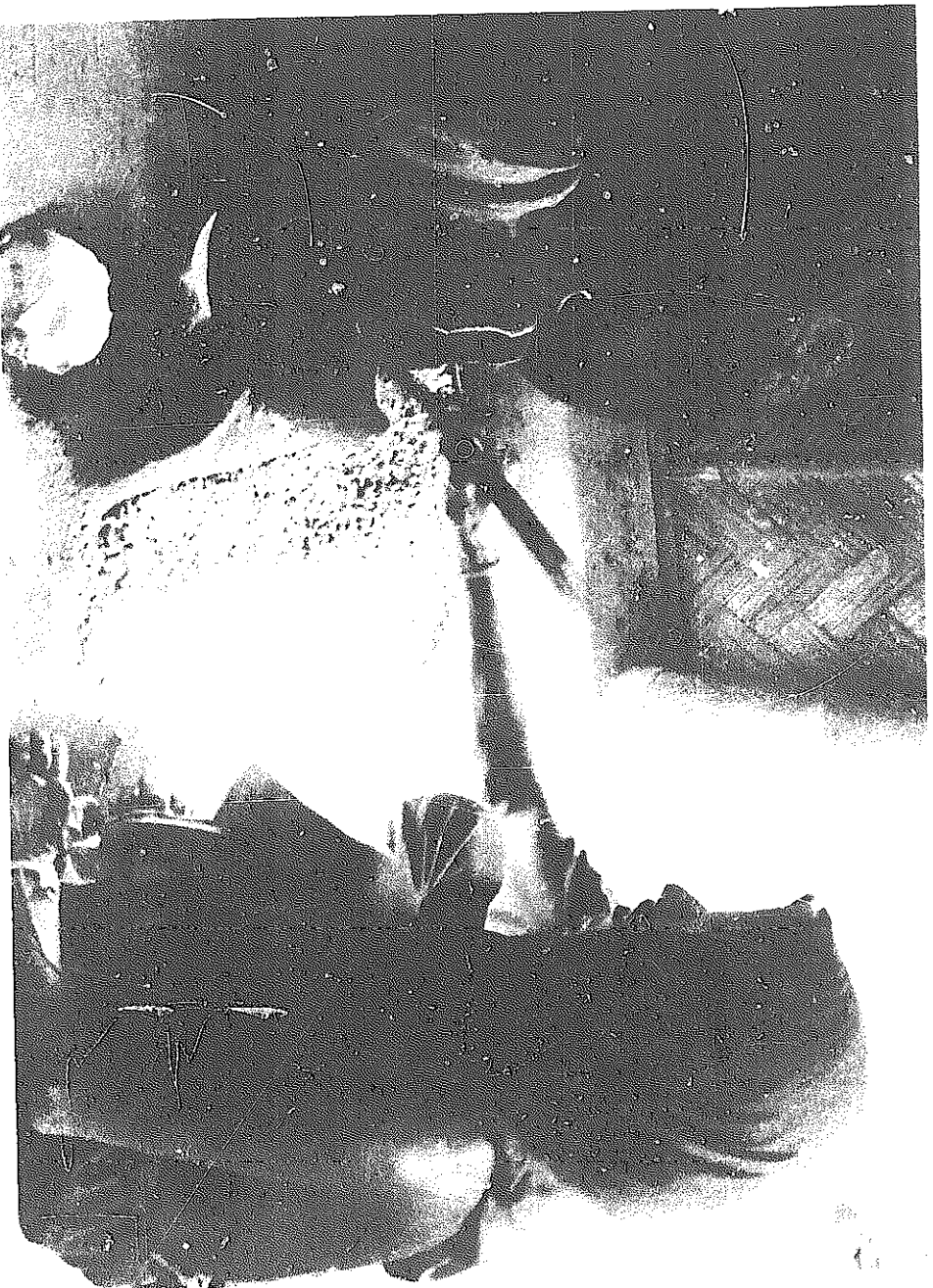

The drying of the grain:

The grain is spread out on the threshing floor or on the public road from sunrise to sunset to dry and the women will turn it over with her foot several times a day. If the amount is large, it will take her several days to complete this process. In the meantime, she has to keep a constant watch on the poultry and birds and much of the grain may be spoilt. She is therefore in a continual state of anxiety throughout the process and will be blamed should anything do wrong.

The Winnowing:

Winnowing is an important as threshing and this is a process entirely carried out by the women. A woman can spend several weeks on this. About 15 - 20% of the paddy grown will lack a kernel and this has to be separated from the rest of the paddy. There are several different ways of doing this, but usually the woman will place some paddy on a flat circular tray, made of bamboo, she then holds this high above her head, in a windy corner as she can find and throws the paddy into the wind. The heavier paddy, containing the kernel, will fall at her feet, the lighter will be blown away by the wind. This is a monotonous and very time consuming task and it is repeated after husking and milling also. The women will use sieves after winnowing to clean the grain still further.

Storage:

The methods of storing paddy follow different patterns in different areas. In areas in which rice is grown on a large scale, small huts raised up off the ground are built of mud and bamboo, and this of course is the best way of protecting the grain. The rice for sale will be stored separately from the rice for the family's use,

In case of the small subsistence farmer, the grain will be stored in a bamboo basket or earthen vessel (a matka) in a corner of the house on a bamboo platform. The basket is sealed by the woman with one or two layers of mud mixed with cow dung and rice husks which is then allowed to dry hard. A bamboo stick will be used to ram the paddy down into the container so that there are no air pockets and a mat placed on top before the mud seal is put on. The opening into the grain store will also be sealed in the same way.

Now that the price of rice has risen so much, rice thieves are a great problem and the women have to continually be on the watch for them and the more traditional predators such as rodents and insects.

Parboiling:

This is desirable as it makes husking easier but is not practiced everywhere and not all the rice is parboiled, the process varies with the different types of rice and in different areas. First the woman makes a stove (*chula*) out of mud in a shady part of her compound. She digs a hole about three to four feet in depth and two feet wide and she places bamboo strips across this and plasters mud on top of them. When the mud has hardened, she cuts circular holes in it to take the cooking pots in which the paddy will be steamed. Wood, twigs, branches, leaves and rejected rice straw and husks are burnt in this stove. She knows from much experience the amount of water to use and how long she must steam the paddy, so that it reaches the stage when it bursts open.

When it is ready, the pots are emptied on to a coarse bamboo mat laid on the threshing floor. The parboiled paddy is spread out in layers to dry in the sun and is turned frequently during the day. The whole process is sometimes repeated again and can take two or three days to complete.

The women will continue with this processing until a substantial amount of paddy is available for the next stage-husking. The paddy is meanwhile stored in baskets, often taking up most of the space in the house.

The men know very little about these processes, but all the women and children living in the compound will take part in them,

Husking:

The main husking is always a big event in a family's life, but it is a process often repeated and the sound of husking can usually be heard somewhere in a village. Two methods are employed. In the first, the woman pounds the grain in a wooden bowl (*khhal*) with a heavy stick (*sia*) which she holds vertically and allows to drop down onto the grain. She can do this by herself or with another woman, pounding in turn. In the second method, she employs a *dheki*. This costs quite a lot to buy, and is made of the wood of a common tree such as mango or jack fruit tree, but it speeds

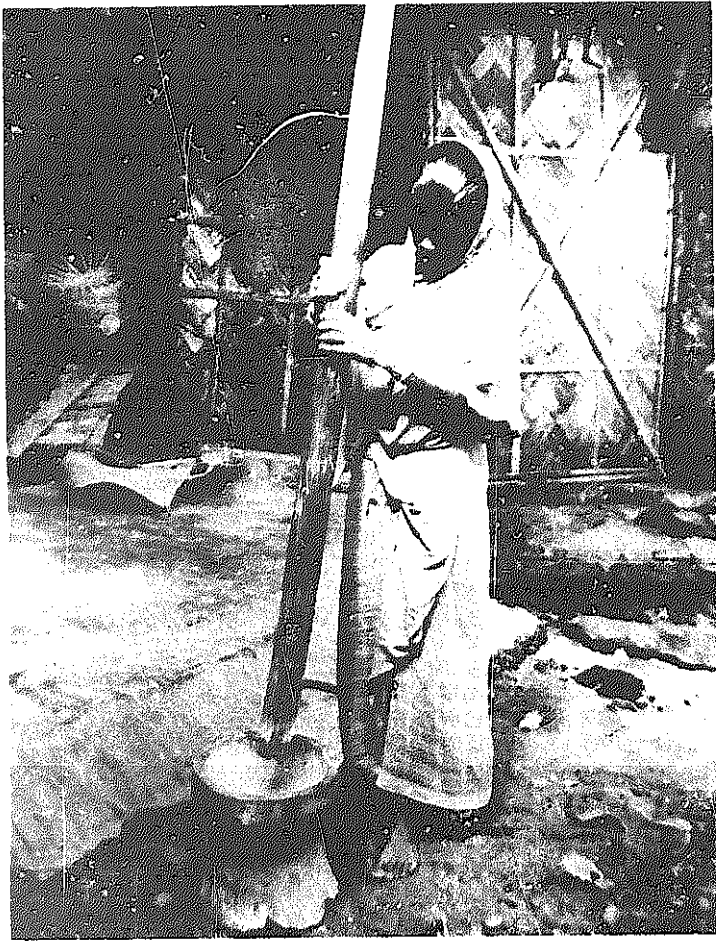

Pounding paddy to hush it

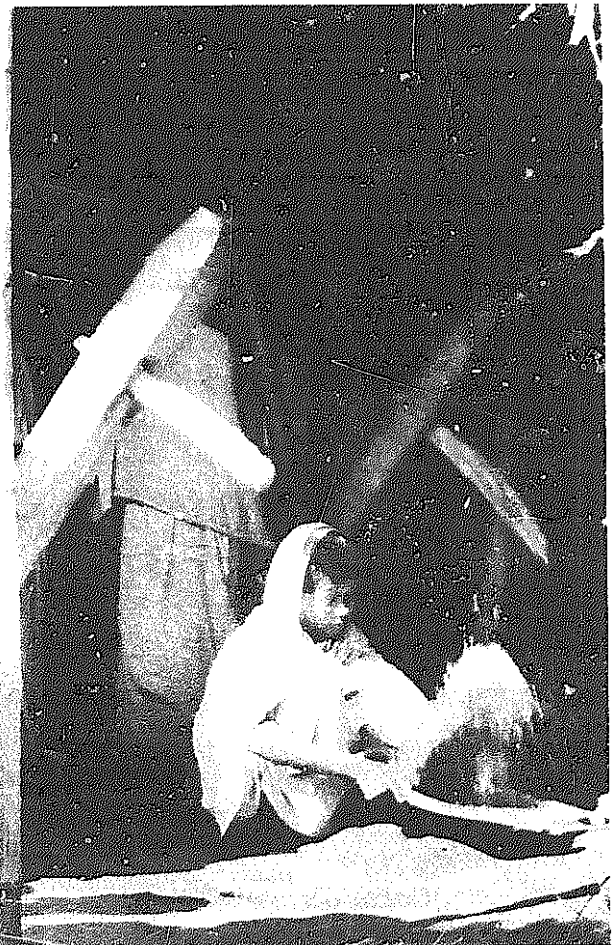

Using a dhecki to husk paddy

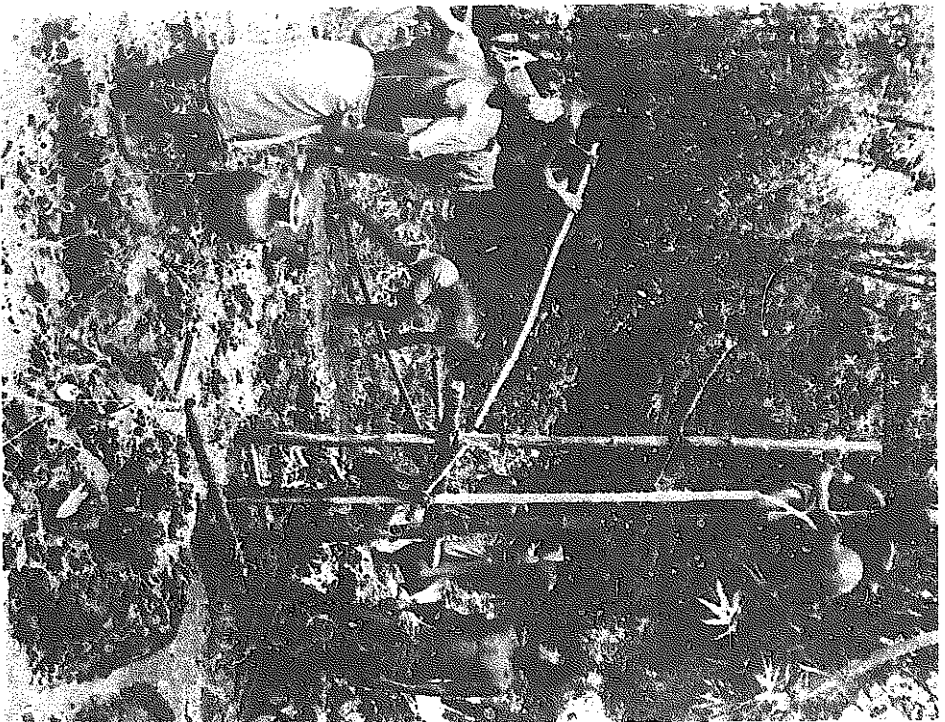

Sinking a tubewell

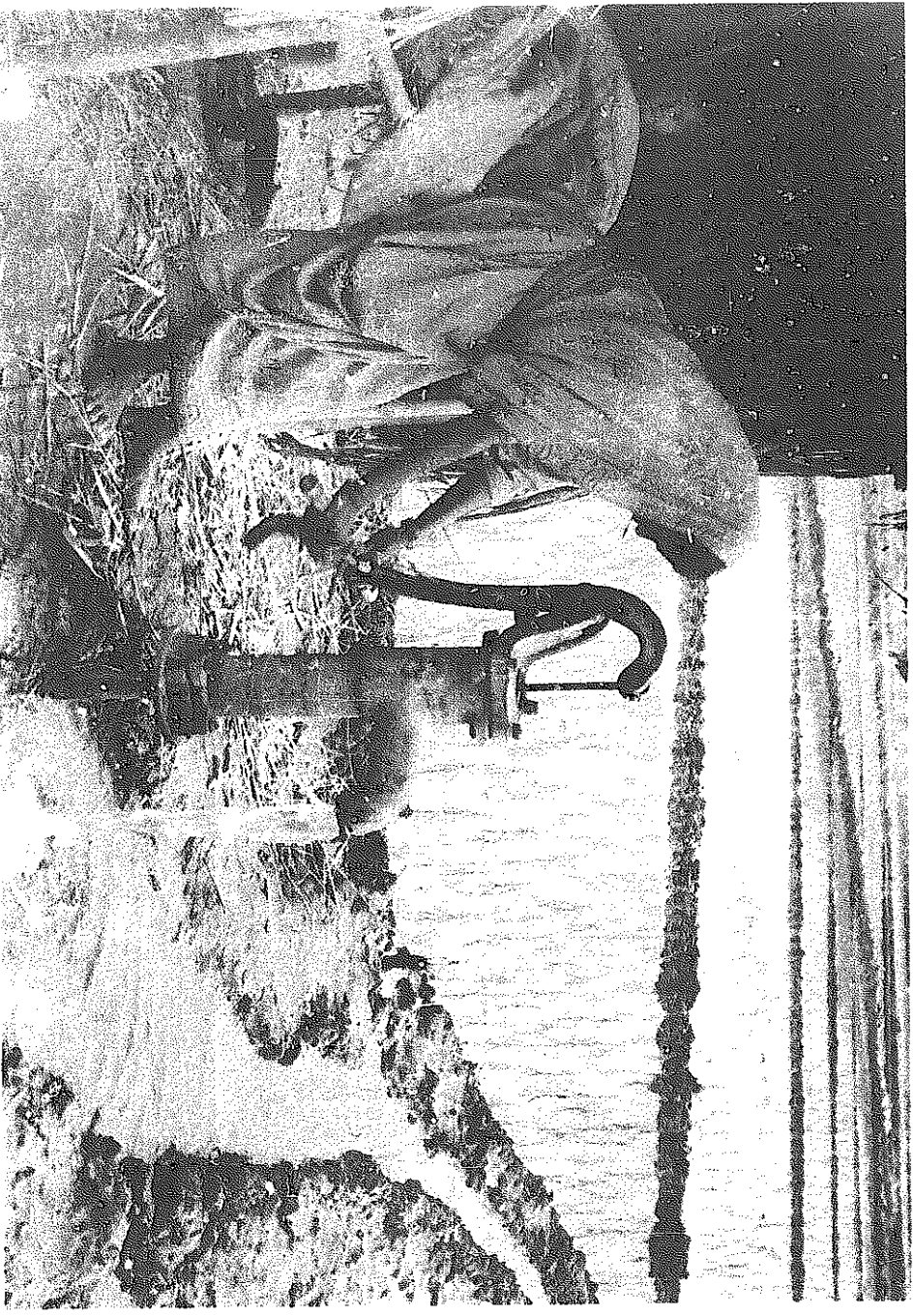

Water for irrigation purpose

up the process considerably and makes the work a little less arduous. It consists of heavy wooden beam suspended by a fulcrum horizontally between two vertical posts and balanced so that the woman can depress it at one end with pressure from her foot, when it is fully raised she removes the pressure, the beam descends and a hard piece of wood mounted on to it at right angles at the other end, drops onto the grain which is in a wooden container. Three women operate this together, two raising the beam in turn with their feet and the third keeping the container filled with paddy. Three women can husk five maunds of paddy in three days by this method (a maund equals 86 lbs). The women often sing songs when husking- paddy, so that they work together in rhythm.

Engine operated rice mills are now beginning to do this husking for the women, but the process is wasteful, since it usually produces only 20-22 seers of rice from a maund of paddy whereas the women get as many as 30 seers by their methods (40 seers equal one maund). These mills also polish the rice and in so doing remove much of its nutritional value.

There are three stages of husking. The first stage (Ak Kara) only removes the outer skin. The second removes the next layer and the third leaves the rice ready for consumption. Rice for sale is processed to the third stage but some people prefer to buy second stage rice, first stage rice is kept for family use and is only eaten when the other rice has been used up.

The paddy husks are used to feed the poultry and the cows and the outer skin is used for fuel so nothing is wasted. The straw is used to feed the cows and is stacked in the compound.

Horticulture:

This is almost entirely the responsibility of the women except where fruits and vegetables are grown on a commercial scale. The women in the Hill Tracts help also with this but this is not customary elsewhere.

The women grow the following, depending on the conditions in the area where they are living:-

VEGETABLES:

Squash
Egg plants
Cucumbers
Pumpkin
Okra
Beans, dwarf end local
cabbage
Cauliflower
Onion
Spinach, sweet and sour
Tomatoes
Potatoes
sweet Potatoes
Kochu

FRUITS:

Pomelo
Guava
Lemon
Lime
Pineapples
Bananas
Plantains
Mangoes
Jack Fruit
coconuts
Lichees
Papaya

SPICES:

Ginger
Turmeric
Pepper
Chilli
Coriander
Cumin
Dill
Garlic
Mint

The women are responsible for preparing the ground and making the seed beds and for watering the plants. When the fruit is on the trees, they have to keep an all night watch to prevent it from being stolen. They harvest it, select seed, dry this and store it and they do the same for the vegetables.

It is their work to put the fencing round the plot and to erect any poles needed to support the creepers.

A woman digs the ground with a hoe (called a spade in Bengali) and also has a sickle. She uses ashes and cow dung for manure. It is a matter of great pride to her that she should be able to supply her family with all that it needs in the way of fruits and vegetables, and she very rarely buys these. She scatters ashes on the vegetables to keep the flies away and to frighten the birds. She makes scare-crows as well as rattles from old tin cans. She will also hang up old discarded cooking pots on wires and painted with spots in line to frighten away evil spirits.

Such things as pulses, grams, lentils and peas are grown in the fields by the men, but the women will be held responsible for preserving these after they have been threshed. Sometimes she leaves them unhusked and stores them in earthen pots and tins with tight fitting lids.

She also makes oil from linseed and other oil seeds, such as til and tishi and from mustard, ground nuts and coconuts and, in some areas, also from cashew nuts.

She crushes pulses in the home by pounding them with a stone or in a mortar, and for larger quantities uses a spice grinder, if she is fortunate enough to possess one.

If the woman has any surplus, she will sell it in the market, but she may not go there herself, she must either send one of her children or ask her husband to do it for her, alternatively she may sell to a middleman who will call at her house. She is therefore very often cheated. If she is able to sell something (perhaps to a woman neighbour, so that her husband is unaware of the transaction) she will do her best to conceal the money from him. She also regards the food that she has stored away as a source of cash in an emergency such as illness.

Animal husbandry:

The women share with the men the responsibility for looking after the cows, bullocks and goats. It is their task to milk, feed and water them.

Yens, ducks and pigeons are, however, the women's responsibility and they attach great importance to this.

They will make the poultry houses themselves out of mud and bamboo and the birds will be locked up in this at night. Hens who are laying will sit in clay pots filled with rice straw. The women make bamboo basket covers to protect the baby chicks and they will collect snails and earth worms to feed to the ducks. When an epidemic breaks out, they will treat them with herbal medicines, such as garlic and pepper and even quinine. Although poultry keeping is a constant worry to the women, they gain great prestige from it and women who have no poultry are looked down upon. The goats are the previous possession of old women and children, as they are easy to care for. During the growing season the goats are tied up and fed on leaves collected by the children. There is a traditional belief that their milk is good for sufferers from Tuberculosis.

Fish Culture:

The man is responsible for catching fish in the canals and rivers, but the women are increasingly taking a part in rearing fish in fish ponds and they are responsible for rearing the fingerlings. There is a drive at present to increase the number of fish ponds but supervision is necessary if they are to be successful. The women will dry any surplus fish the men may catch, especially *hilsa*, by cleaning them and dipping them in brine, but the methods used are often crude and unhygienic and needs improving.

MEANING OF INTERMEDIATE TECHNOLOGY
(How it could help the rural women in Bangladesh)

The term Intermediate Technology is frequently heard now-a-days, but not every one is yet aware of exactly what it means. Intermediate technologies may be defined as these which are an improvement on the ones already in use but which are not too advanced to afford a half way stage between the sophisticated and costly technologies used now in most of the richer countries and the simpler and sometimes too primitive methods employed in some of the poorer ones. They are also meant to be technologies which are appropriate to the circumstances in which they are to be used, hence another term which is also often heard and is equally valid - "Appropriate" Technology. "Village" Technology is also sometimes used but has less precise meaning.

The Intermediate Technology movement - for such it can now be called, - owes much of its inspiration to the late Dr. "Fritz" Schumacher, the economist and author of the best seller "Small is Beautiful". In this he argued that Man's current pursuit of profit and progress and the fragmentation of expertise, which has led to technologist, scientist and economist all working independently from each other, has led to economic inefficiency, environmental pollution and inhumane working conditions. He points out that, when an advanced technology is introduced, the Intermediate Technologies employed until then, gradually disappear so that, for example, a farmer, who cannot afford a tractor is forced out of business because he can no longer obtain draught animals to pull his plough. Because of the same pressures non-electric typewriters are not now manufactured in many countries, nor are such things as kerosene operated refrigerators or fans, with the result that, people living in areas where there is no electricity now, live more uncomfortably than they did thirty years ago, when these items were still obtainable, their standard of living has gone down - not up.

The historical reasons which have led to the West being so dependent on machines are often forgotten. The Industrial Revolution in the 18th century in Britain (which led to large numbers of farm labourers going to live in the towns to work in the newly established factories) and the colonising of the great open spaces of both North America and Australia, forced the farmers to turn to mechanisation if they were to be able to grow sufficient food to feed the people who were no longer growing their own. This situation, however, is absent in most of the developing countries today, where man power is readily available and most rural people grow their own food, but it is being created in those which are becoming industrialised. It is not technological backwardness which leads many Asian countries to use thousands of workers to construct roads and dams in circumstances where the developed countries would use bulldozers, but the need to find employment for these people who, without it, will go hungry, and a capital intensive, highly automated plastic shoe factory turning out several million shoes a year is of doubtful benefit to the economy if it puts out of work three or four thousands leather workers who formerly made these shoes by hand,

The followers of Dr. Schumacher's teachings therefore seek to introduce and, where necessary, evolve, simpler technologies more suited to the circumstances in which they are to be introduced, which will also employ local materials and labour whenever possible. This is not to say, however, that they are for one moment advocating that the poorer countries should be content with technologies which the richer have discarded but that, with the benefit of hindsight, these countries now have the opportunity of avoiding the trip into which the developed countries have fallen with their over dependence on resources which are rapidly running out or are becoming too costly to use - such as fossil fuel. In fact, a number of developed countries are themselves now seeking to revive technologies which were in use for many centuries until the advent of the petrol engine rendered them, as it was then, obsolete. The use of wind and water power to generate electricity to pump water or to turn grinding mills is still possible today.

But if a shortage of manpower is rarely a problem in the poorer countries unacceptably arduous labour often is and this should obviously be reduced where ever possible. Quite simple means can often achieve this, the addition of ball bearings to a potter's wheel will increase his out-put three fold because the wheel will turn more smoothly, breakers fitted to hand carts will make them easier to restrain - when going down hill and gears would make a rickshaw driver's life much less hard than it is now. Trees which are at present cut down by hand could be felled by a hand held chain saw instead, (and

far more cheaply than by bull dozers) whilst grinding mills, introduced into women's programmes in several countries, have saved then much hard labour in grinding their maize and wheat into flour between two stones, nor do these destroy the vitamin content as many larger engine turned mills do.

Rural women in particular, could be helped a great deal by simple technologies which could make their present tasks much lighter. Many people do not realise now, how heavy their workload is and how badly they need help, help if their health and that of their children (and therefore of the nation) is to be improved.

In introducing new technologies, however, care needs to be taken to see that these do not conflict with local customs or they may do more harm than good. Technologies should be adapted to the people - not the people to them and those that evolve naturally from ones already in use are the best because there will be less difficulty in introducing them. A machine which perhaps requires a rotating action will be resisted by the women if their muscles are more accustomed to a pounding one.

The division of labour between the sexes also which differs everywhere, needs careful study especially as, in many countries now, the women enjoy considerable prestige as the growers of food for their families which they will lose if the pattern of living is changed too drastically. A well meant, but unfortunate attempt in one Asian country to help the women, by substituting scythes for sickles when harvesting paddy, let to the men taking those over because they were too heavy for the women, with the result that these lost their livelihood, and a pedal operated grinding mill introduced into another country suffered the same fate because local custom forbade the women to sit astride. Customs can, of course, be changed but it is usually a very lengthy procedure and one better not attempt, unless time is of no importance. Women are usually less resistant to change than men, but need first to be convinced. quite understandably, that this is for the better.

The Intermediate Technology Development Group was founded in London, as far back as 1965 but there are now a number of similar bodies throughout the world in Developing as well as Developed countries, including the Appropriate Technology Cell in Dacca, which was set up by the Bangladesh Agricultural Research Council about a year ago. All of these organisations are able and willing to advise on simple technologies which could help to improve the quality of

life for both men and women in urban as well as rural areas and many have published helpful handbooks on a variety of subjects, which would be of help to anyone engaged in a rural development programme.

Is an annexure to this report, selection from some of these have been included in a handbook of "Simple technologies for rural women in Bangladesh", and there is also a bibliography. It is not suggested that all of these ideas are necessarily ones which the women could carry out themselves unaided but the simple, manually operated, machines illustrated together with the names and addresses of their suppliers, may be of interest to planners of rural development programmes for women as well, as to the various women's organisations in Bangladesh.

Ways in which Intermediate Technology
could be used to help the women in Bangladesh

As has been set out in detail elsewhere in the report, the majority of the rural women in Bangladesh are occupied at all seasons of the year, from the moment that they get up, at first light, until they go to bed, so that unless this work can first be reduced there is a danger that the introduction of other activities, even those designed to help them increase their income, may, instead, prove to be the proverbial last straw which breaks their backs. If their present activities do not actually generate income now they are at least saving because, if they did not undertake these tasks, their husbands would have to pay someone else to do so.

The rural women can be divided into three main groups, whose circumstances differ considerably. First there are the so called "destitute" woman - widows and women who have been divorced or have lost their families and who have, therefore to hire themselves out as labourers in the fields or as servants to the other villagers, they are usually the only women to be seen working in the fields, except in the Hill Tracts.

The next group - the largest. can be sub-divided into those women whose husbands do not own land, so that these work as hired labour to other farmers, and those whose husbands either rent or own a small farm of their own. Both sets of women, however,

have much the same tasks to carry out and, because they have trained from childhood to efface themselves in a largely male oriented world and work mostly in the privacy of their own compounds, many men, and sometimes even their own husbands, do not always realise how much they have to do. In addition to the household duties expected of women everywhere, they carry out most of the food processing, including threshing, husking, winnowing and drying the grain and these are time consuming and monotonous tasks. Most of them will also keep a kitchen garden, in which they will grow fruit and vegetables and spices for the family's consumption and may keep poultry as well. They must fetch water for the household and the animals and search for fuel for cooking purposes and in their "free" time they will make household articles such as baskets, nets, mats, winnowing trays, jute hangings and bed quilts, some may even make their own clay pots.

The final group of women consists of the slightly more prosperous ones - the wives of the larger landowners and the shopkeepers etc., who are able to afford servants and to hire labour so that these are the women best able at present, to take advantage of most of the existing programmes for the rural women because they are the only ones with any leisure to speak of and are also the best educated.

In theory, the "destitute" women should also have the time to take part in these programmes because they do not have the heavy responsibilities of the second group of women but, in practice, it would appear that they do not always do so. They are perhaps understandably, reluctant to mix with the other "better off" women, especially in activities which may require a certain degree of literacy. Many of them do take part in the Food for Work programme, but this is seasonal and the rest of the time they are hard pressed to earn a living. It is these women, therefore, who are most likely to benefit from income-generating activities and it is suggested in the recommendations that inter alia, they might be employed bottling or drying surplus fruit and vegetables during the season and making soap.

Much of the food processing that the middle group of women carry out could be lightened by the introduction of simple machines, which custom would permit them to use if these were manually operated, and some suitable for this purpose are illustrated in the annexure "Simple Technologies for Rural Women in Bangladesh."

It is not suggested that these should be purchased by individuals - few women would be able to afford them - but that one should be owned collectively by a number of women and used in rotation, but in order to do this they will, of course, first require help in obtaining long term credit or a loan - which might be on a revolving basis so that, when one machine has been paid for, the money is available to buy another one. It is best that they should pay for these machines themselves, however, or they will not value them.

A similar programme to the one suggested was carried out in Africa where hand operated grinding mills saved the women some fifteen hours a week each formerly spent in grinding the maize into flour between two stones. The women were formed into groups and in order to obtain the money for the mills these started their own group farms and sold the produce in the market, thus having the indirect result that food became much more plentiful. Once they had become accustomed to working together it was easy to introduce other programmes, such as one on child welfare, meanwhile the profits from the group farm were used to finance other activities, the "binding" agency, however, was the corn mill.

It should therefore be possible to develop a programme of the same type in Bangladesh, using winnowing or threshing or husking machines instead, the latter especially could be of great benefit to the women but, although three possible machines have been included in the handbook, it must be admitted that none of these is ideal, as yet, and it is to be hoped that some agency will soon market a better version. Meanwhile the *dheki* already used in some areas in Bangladesh is an improvement on the other methods used and the women do not yet have these might be assisted to obtain them.

Whatever machines are obtained, however, these will need to be supervised in the early stages, because there will inevitably be some troubles until the women have become accustomed to using them, someone will also have to see that repayments of any money received are made on time so that a programme of this nature could probably only succeed if one or more of the national women's organisations is prepared to sponsor it, whichever do so, however, will find that they will be repaid by an increased confidence on the part of the women in any other proposals they may make.

As for the other tasks women carry out, they could be relieved from the burden of having to carry water by the provision of still more wells, as well as improvements to existing ones, and hand pumps fitted to these would prevent pollution. It ought also to be possible to arrange for pumps which are used solely for irrigation purposes now to be used, at night time, to pump water into

storage tanks in the neighbouring village end, stand pipes, where these exist, could be made higher so that small children could shower under them, whilst larger surrounds would make it easier for the women to wash their clothes there.

Bio-gas (also known as Gobar gas) plants could make much more efficient use of the dung which the women use now for cooking purposes and would also provide fertiliser for the kitchen gardens as the residue, after the methane gas has been extracted, is rich in phosphates, nitrogen and potash, whilst firewood shortages could be remedied by fuel plantations of self-regenerating trees and bamboo might also be planted on a larger scale, at present it is quite unnecessarily expensive because of scarcity.

Given sufficient bamboo and poles from the forest, houses, in areas liable to flooding, might be built up on stilts, above the normal flood level, as they are in most of the neighbouring countries subject to seasonal flooding, and grain stores, raised up in the same way, would keep rats out of the grain as well as the grain out of the water. Drying floors might also be provided in the villages to stop the present practice of drying the grain on the roads - because in the monsoon, these are often the only area of dry land of any size. Not only is this dangerous, much of the grain is lost when vehicles pass over it.

Fruit and vegetables which are at present wasted in seasonal gluts could be preserved by bottling under pressure in "Mason" or "Kilner" jars and full particulars of this process, together with receipts, are given in the second annexure to this report "A Manual of Food Preservation". They could also be preserved by drying in the sun and the grain drying floors already suggested could be used for this purpose too. It would be essential, though, for both processes to be carried out under close supervision to ensure the necessary hygienic standards so that, here again, the women's organisations could play a most valuable part in organising this.

They might also consider helping the village women to market their surplus produce, at present their husbands or children must take it to market for them because custom does not permit them to go there themselves and they do not always receive their money when these get back. Alternatively, they sometimes sell to a middle man, who gives them very little (but at least pays the money to them) but they would receive a fairer price if they could sell to a women's marketing group instead.

Pineapples grow well in Bangladesh so that, quite possibly a small cottage industry could be set up processing the fibre which comes from the leaves and which, in the Philippines and Taiwan is used to make all sorts of baskets and cloth. South Africa is also experimenting with using pineapple fibre as a substitute for jute. However, the poorer the fruit the better the fibre and, as Bangladesh pineapples are excellent, and jute is a major industry here already, it might be better to think in terms of canning these instead. This could provide opportunities of employment for women but on a larger, commercial scales somewhat outside the terms of this report.

The rearing of fingerlings is something which the women might also be encouraged to do as an income generating activity - though this, again, will require supervision and soap making might be undertaken by the poorer "destitute" women when they were not engaged in bottling, recipes are given.

Any programme to improve the standard of living in the villages should be part of an integrated whole. It will not greatly help the women just to introduce a threshing machine to a water pump without any follow up or maintenance. Technologies thus introduced in isolation, as many often are, lose much of their value, properly used they can be the means to an end, in this particular case the end should be a reduction of the rural women's workload and the consequent improvement in her health and that of her children.

HOMESTEAD

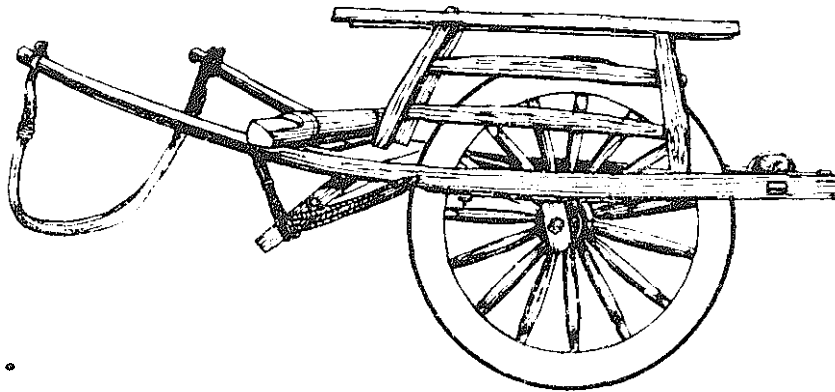

1.

A CHINESE WHEELBARROW. This has only one wheel and so can travel along very narrow paths. Loads of equal weight must be balanced on each side of the wheel to keep it upright.



- Carrying aids: (a) carrying support with flattened buckets; (b) carrying pole with supporting stick.

Three ways of carrying loads suspended from the shoulders

FILTERING WATER

Drinking water should always be boiled for at least five minutes, It is also good to filter it .

The picture shows two earthen pots. The top one has had a small hole bored into the bottom of it through which the water drips into the bottom jar. In the top jar a layer of small stones has first been placed and, on top of these, has been placed a layer of charcoal crushed into small pieces. The stones and the sand must be washed before putting them in the pot, The water will pass through these layers and they will remove much of the suspended matter.

From time to time the layers should be taken out and washed and then put back again,

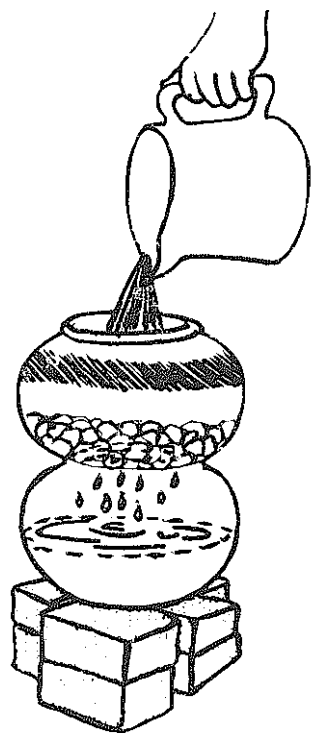

2.

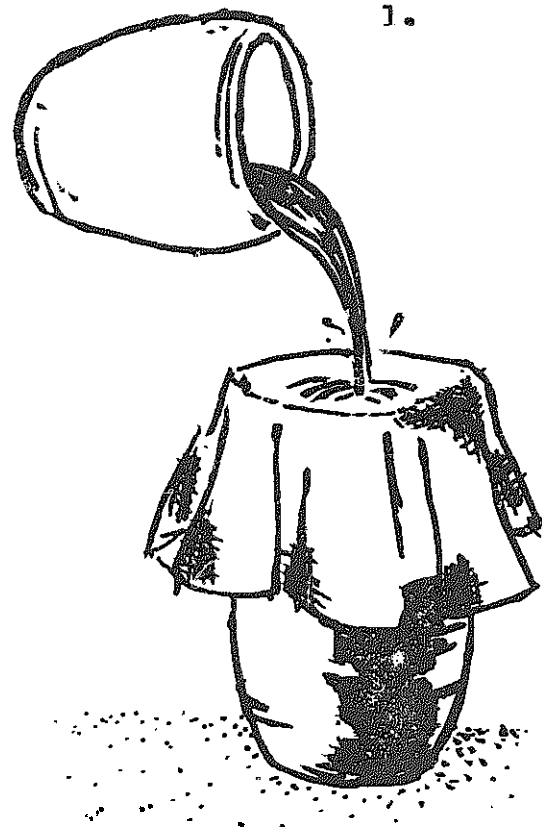

1.

Another way of removing impurities from the water.

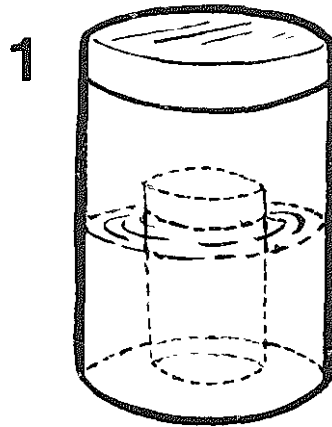

Three ways of
keeping food
cool.

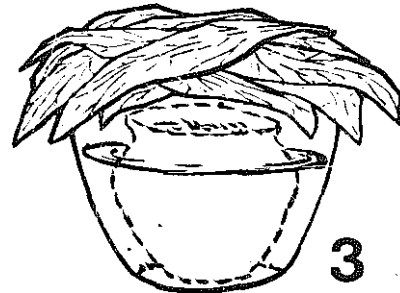
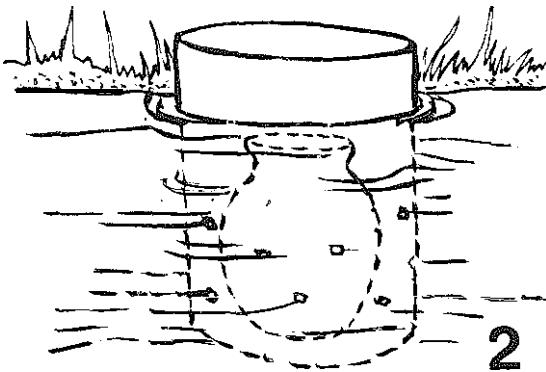

COOL WATER

4. If a kalsi is filled with water and then hung up outside in strong sunlight, by means of a piece of rope tied round its neck, the water inside will stay cool and be good to drink.

The kalsi must hang, not be placed on the ground, so that the air passes under it and must not be glazed, The water will cool by evaporation and this is why it must be in the sun

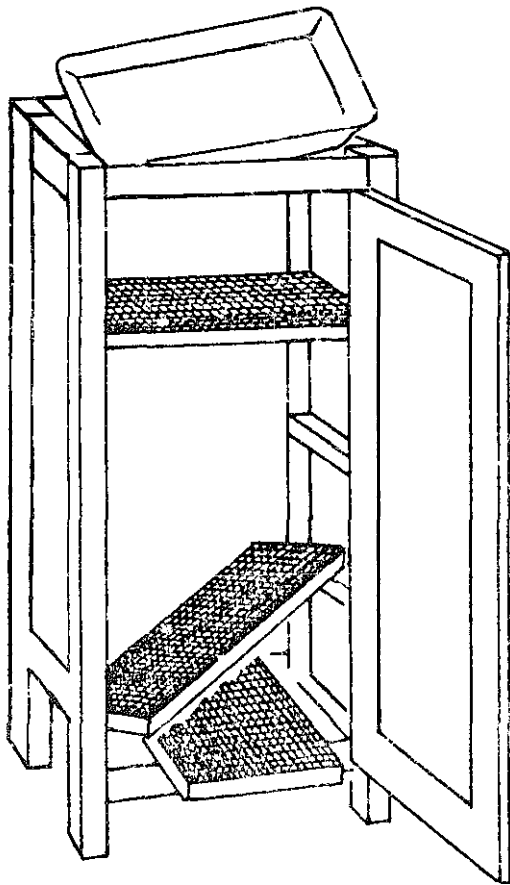

Framework of iceless refrigerator.

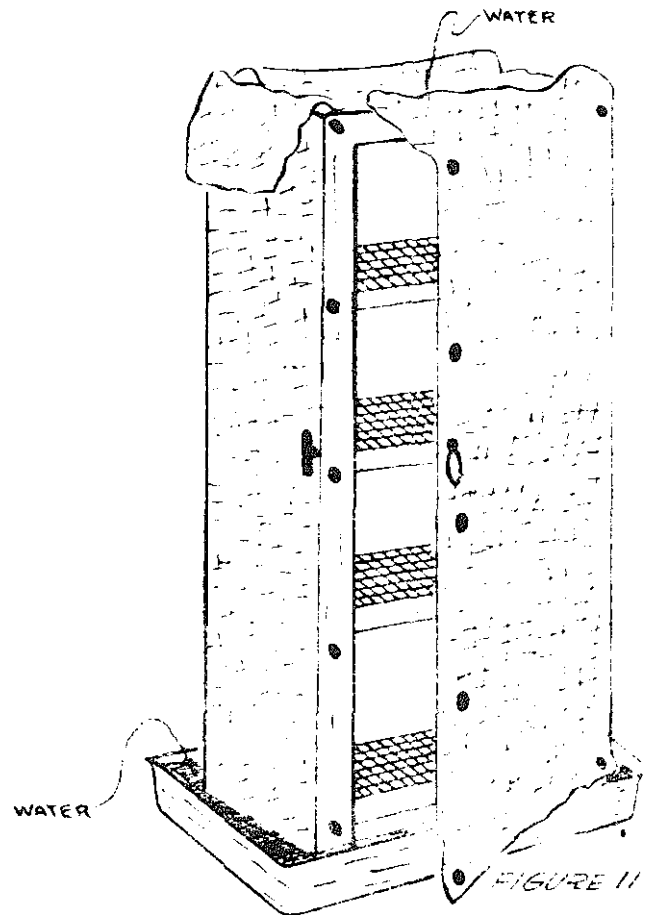

AN ALMIRAH TO KEEP FOOD COOL

Make a wooden frame similar to the one shown in picture 1 to the desired size, but not larger than 56 inches high or 12 - 14 inches wide. The shelves inside should be removable. If it is possible put wire netting on the sides and top but this is not essential.

Obtain a flat metal tray about 4 inches deep and a little larger than the base of the frame and stand the almirah inside this. Obtain a similar tray or a bucket for the top of the almirah.

Cover the frame loosely with hessian, as shown in picture 2 and allow this to hang down in to the bottom tray, this is most important.

On the top of the almirah sew four wicks (salta), such as are used in lamps, on to the hessian, then put water in the upper tray, or bucket, and stand this on top of the almirah, put the loose ends of these wicks into the water. Always keep this tray full of water.

Put water in the bottom tray also. The first time the Almirah is used wet the hessian all over. Stand the almirah in a shady place where there is plenty of air to blow round it, and the food inside will stay cool through evaporation.

SECOND ICELESS COOLER

Take a large pot with a wide mouth and a basket small enough to go inside it. Put two bricks inside the pot on which the basket can stand. Make a lid for the basket and sew a piece of **hessian** round the rim so that it hangs loose at the bottom of the basket. Put the food inside the basket and then place this inside the pot standing on the bricks. Put a little water inside the pot and let the **hessian** from the basket hang down **into this, also**, the first time, make the **hessian** itself wet, but do NOT let the basket itself stand in the water, it should be just above it, on the bricks. If the **hessian** cloth is in the water at the bottom of the pot it will stay wet a long time and will keep the food in the basket cool.

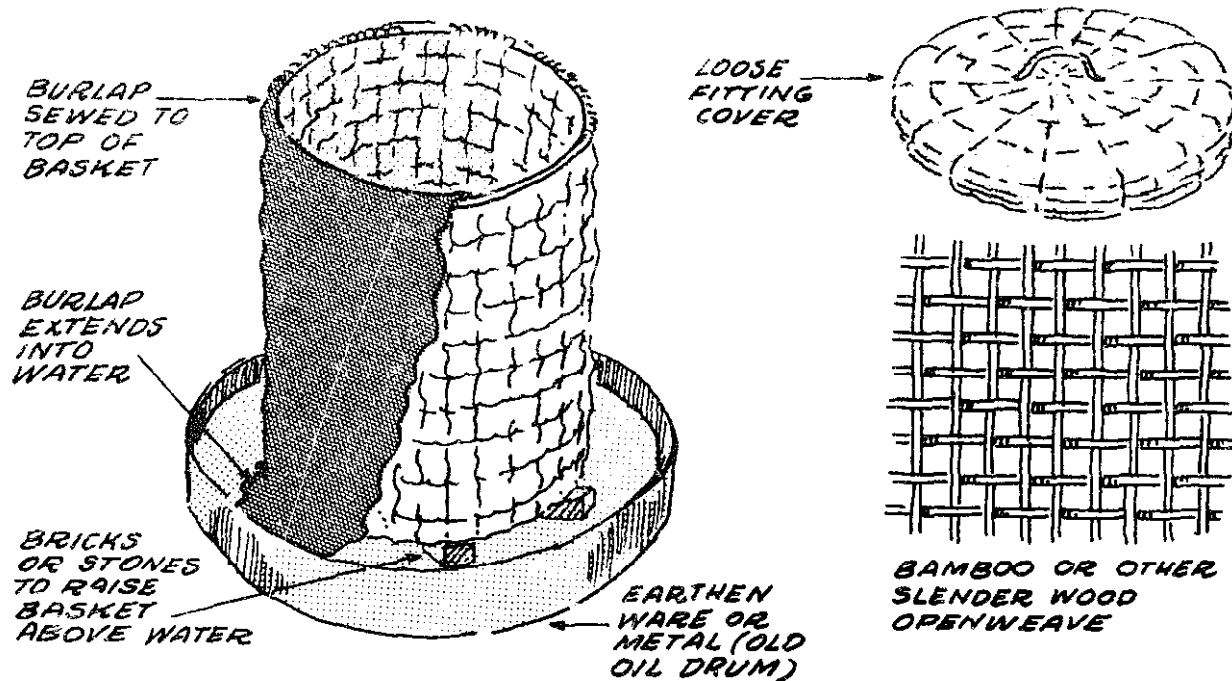

1.

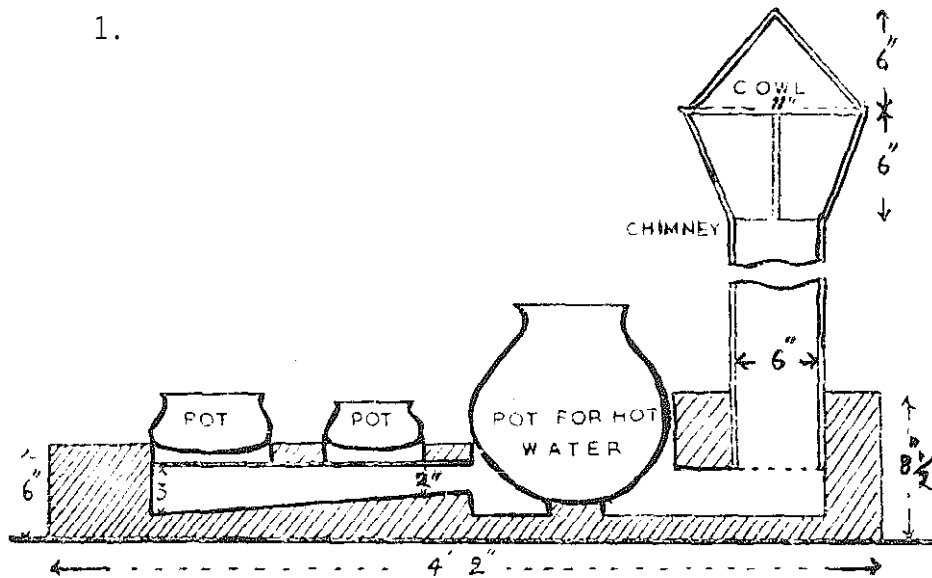

IMPROVED CHULA

The drawings show an improved type of **chula** which can be made out of mud or brick. Measurements are shown on the plans. The diameters of the holes in the top should be about an inch smaller than the pots which will be used on them and any holes which are not in use should be covered over to prevent the smoke coming out and also to stop a back draught.

The floor of the fire duct should slope slightly upwards as shown in picture 1. A step, or ledge should be built underneath the opening for the fire wood to stop long pieces falling out on to the floor,

Picture 3 shows the chimney going straight up through the roof, when this is of tin or of tiles. Picture 4 shows how it should be bent away from the roof when this is made of more inflammable material.

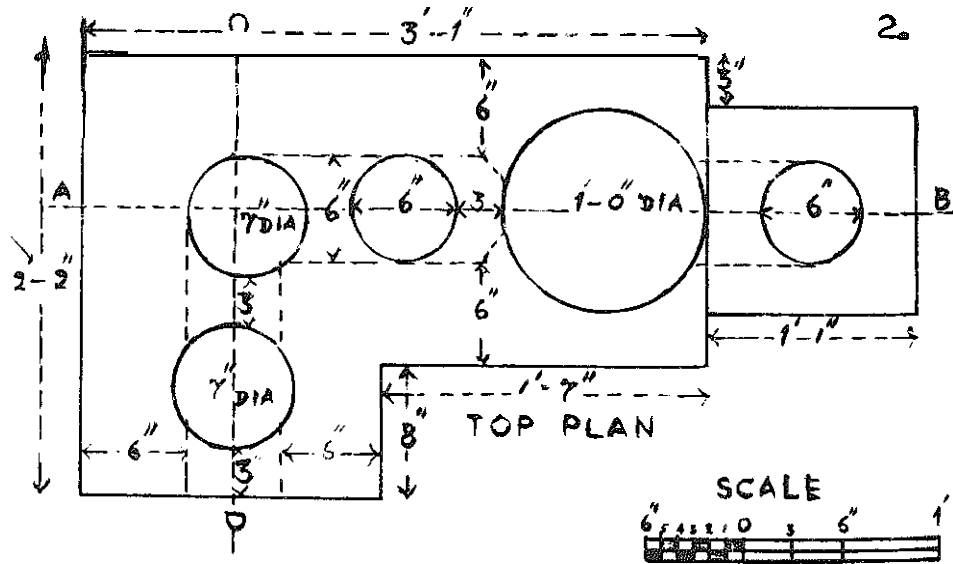

PLANS FOR IMPROVED CHULA

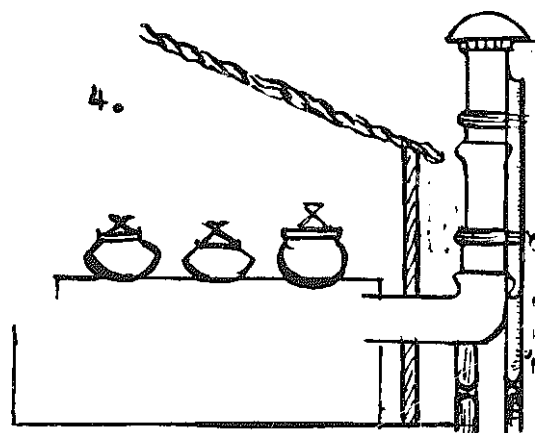
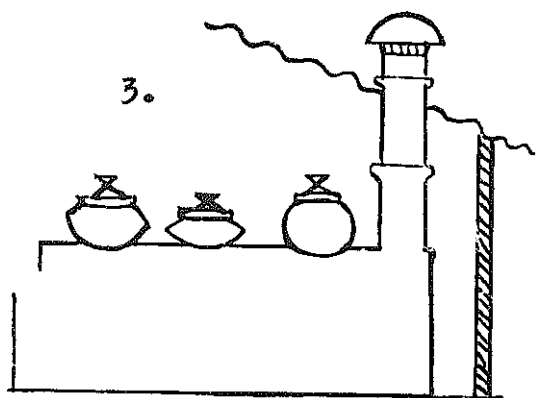

A stove using rice hulls (husks) which will save fuel.
Use a four gallon kerosene or similar tin to make the stove.

Rice Hull Stove

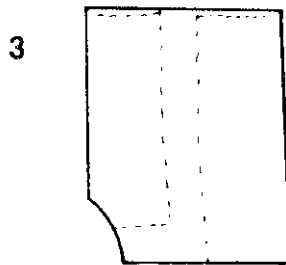
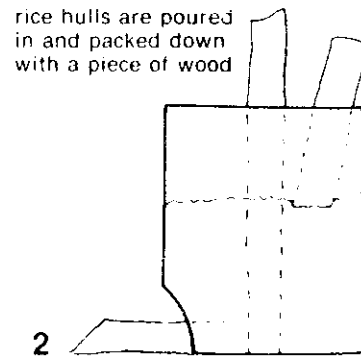
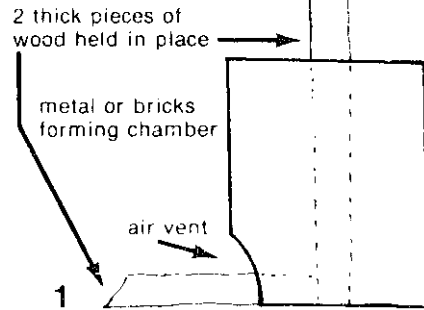

When the chamber is filled up to 1-2 inches from the top, the pieces of wood are carefully removed, leaving an air vent and chimney.

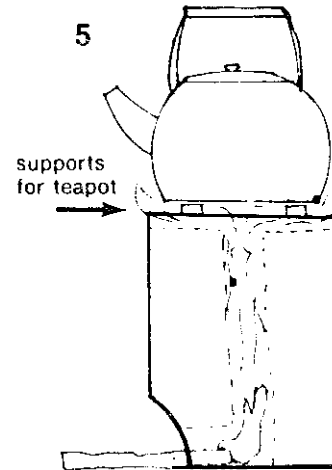
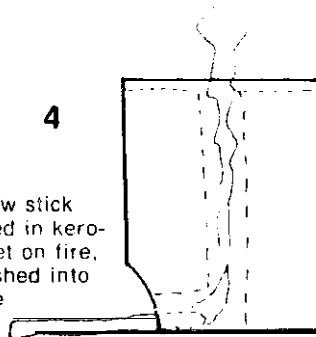

The burning stick pushed in through the bottom opening, to **start** the husks **burning, must** be only half the width of the opening or it will shut out the air. A one yard long piece of wood, pushed in further as the end burns up and a full tin of rice husks will provide a usable cooking flame for about two hours.

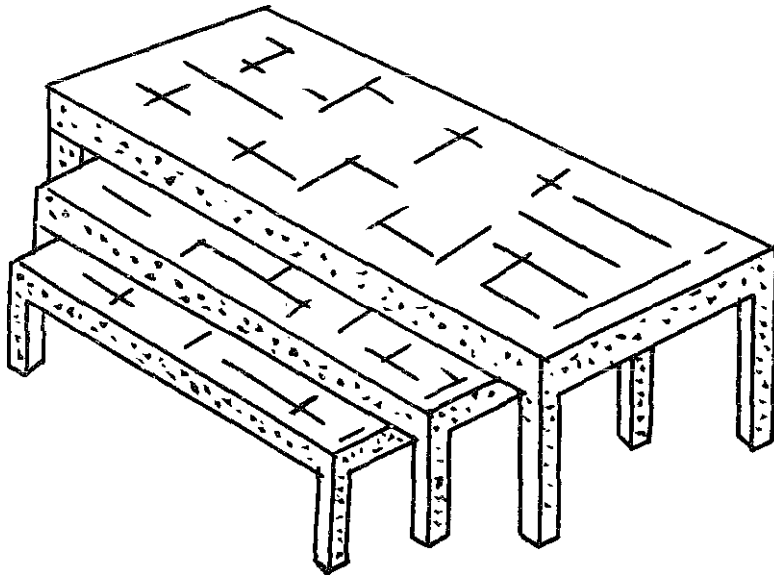

If the space in a house is limited make each wooden cot a little shorter and a little lower than the other ones, then, in daytime, they can be placed under one another, as the picture shows.

Another way of saving space is to **build** one bed above the other, as is done in ships and in the **sleeping** compartments on trains.

Two ways of keeping rats away. **These** can also be placed on ropes so that they cannot run up or down these.

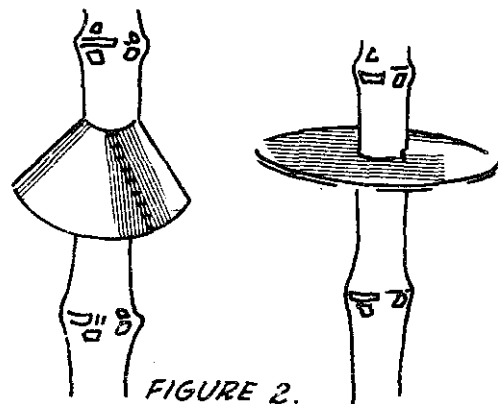

FIGURE 2.

A HAY BOX

Put a layer of hay, straw or rice husks in the bottom of a wooden or tin box and make a lid for this and pad it with some **old, clean** cloth.

Stand the cooking pot you intend to use on this layer and pack the hay, straw or rice husks tightly round it, then take out the pot.

Put inside it whatever you intend to cook and put the pot on the chula to get hot. When the contents are boiling take the pot off the chula and put it back in the hay box. Put the lid on the cooking pot and the other lid on the hay box to keep the heat in.

Leave the cooking pot in the box for several **hours, the** pot will stay hot and the food will go on cooking inside it.

If you do not have a suitable box a large, wide mouthed jar will **do, providing** that it is **large** enough to take the cooking pot and if it has a lid to keep the heat in.

Cooking food **this way you** will use very **little** fuel, only what is necessary to bring the pot to the boil.

SOAP MAKING

'RECIPE NO.1

Required :- 5 bottles of oil **1** pint size
 3 bottles of water 1 pint size
 1 tin of caustic soda 1 lb size
 1 large enamel or earthenware bowl
 1 smaller bowl

DO NOT USE **ALUMINIUM** FOR THESE
 Suitable moulds for the soap, or this
can be poured into a wooden box or a
 strong card board box.

Put the water into the smaller basin end then, very carefully, pour the caustic soda from the tin into the water. **NEVER PUT THE WATER INTO THE CAUSTIC SODA, THIS IS DANGEROUS.** The water will bubble up when the soda is poured in but this is **quite correct.** Do not let any of this mixture splash on to your skin or clothes or put your finger in it or it will burn you,

Leave this for several hours to cool down BUT BE VERY CAREFUL THAT CHILDREN OR ANIMALS CAN NOT GET AT IT **OR IT WILL HARM THEM.**

The next day melt the oil in a pan over the fire **and** then pour it into the large bowl to cool. When it is ready very slowly and steadily pour the first mixture **,of** caustic soda and water, into this oil **,stirring** slowly all the time., with a wooden spoon **and for** about 48 minutes. When it 'begins to thicken pour it into the moulds or the boxes, having first lined these with sheets of paper so that the soap will be easy to lift out (an old piece of cloth would also do)

Leave the soap to cool for a day or two **and** then take it out of the box and cut it up into pieces with a sharp knife or by means of a thin piece of wire held tightly stretched in the hands.

This recipe is for soap for washing clothes. **Any** vegetable oil will do .

HOW TO CORRECT MISTAKES

If your soap is unsatisfactory it may be because : -

1. You used rancid or salty fat
2. You used too cold or too hot a temperature, stirred the soap too vigorously or did not mix it very thoroughly.

To put matters right : -

1. Cut up or shred the soap into a pot and add the lye which separated **out**.
2. Add 5 pints of water (5 bottles)
3. Melt the soap in a gentle **heat, stir occasionally**.
4. **Raise** the heat and boil the soap gently until it becomes thick and jelly like and drops in sheets from the spoon .
5. Pour it into a **mould** and cover it and let it stand **for** 48 hours. Then cut it up.

Always : -

Measure carefully
 Have lye and water mixture only **luke-**
w - 9 at body temperature .
 Stir slowly and in the same direction .

SECOND RECIPE FOR SOAP

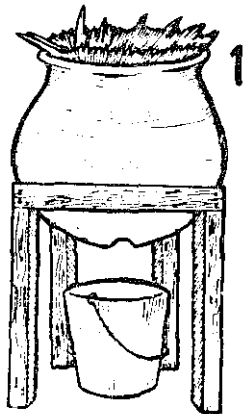

Make this in the same way as shown on page 11.

- | | |
|---------------|------------------------------------|
| 13 cups | Vegetable oil or animal fat |
| 13 ozs | Caustic soda |
| 5 cups | Water , rain water is best. |

This will make 9 pounds of soap.

RECIPE FOR MAKING LYE

Caustic soda is necessary to make hard soap, for washing clothes but, if it is not **obtainable**, it is possible to make soft soap with home made lye. Remember that, just as with caustic **soda**, **THIS CAN BURN** so be very careful not to let it splash on to the skin. Should this happen by accident wash the skin well and then wash it again with a solution of water and vinegar. Be very careful to keep the pot and the bucket out of the reach of children or animals.

To make lye **take** an earthenware pot with a hole in it and put this on a stand, as shown in picture 1. Place a bucket beneath the hole, Put some straw in the pot to act as a **filter**. Fill the pot with wood ashes, scoop a hole-in the middle' of these and fill this with water, add more water each day as the ashes absorb the water. The lye will drip through into the bucket beneath. Continue to do this for 3 weeks. Then take an uncooked, raw, potato end put it into the bucket, do this with a spoon, do not get the lye on your hands. If the potato floats the lye is ready for use, if hot, wait a little longer.

The ashes can be used **again** but the lye will not be so strong the second time, Use the lye in the same way as the caustic soda.

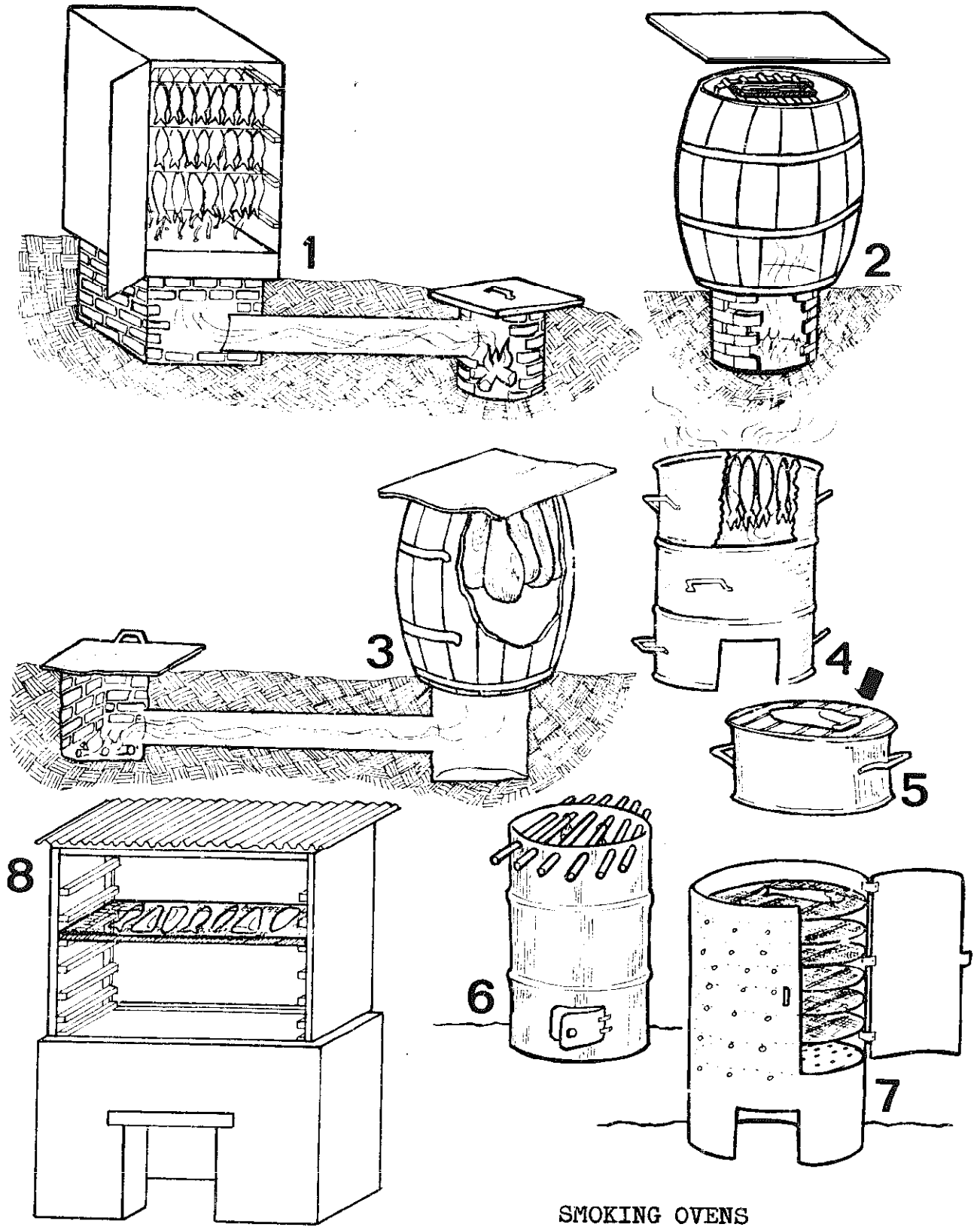

SMOKING OVENS

OVENS FOR SMOKING FISH e t c .

Various types

1. Permanent-type oven with remote brick fire pit underground. Fire pit cover of sheet metal.
2. Improvised oven from wooden barrel with brick fire pit underground. Barrel cover of sheet metal.
3. Improvised oven from wooden barrel with remote brick fire pit underground. Barrel and fire pit covers of sheet metal.
4. Improvised oven from oil drum cut in three sections. Lowest section used for firebox. Middle and top sections fitted with bars from which the fish or meat is hung.
5. One section of the three-tier improvised oven shown in 4.
6. Improvised oven from oil drum showing door in firebox and only one set of bars for hanging the fish or meat.
7. Improvised oven from oil drum fitted with trays and door.
8. Simple Altona-type oven.

HOW TO SMOKE FISH

A. You will need:

1. Small whole fish, small split fish, large split fish or fillets.
2. Five to six parts of water to one part of salt for the brine solution, if pre-salting or brining is to be used.

B. When smoking is done for preservation, the main objective is to cook and dry the fish. The name of the process is smoke-drying. The drying can be partially or fully accomplished inside the smoker. When it is only partially accomplished within the smoker, it is continued outside the smoker, normally as sun-drying. When fish are prepared for smoke-drying they are not usually pre-salted or brined because salting depends upon local taste preferences and local conditions, and may be omitted if desired. Dependent upon climatic conditions, salt is advantageous for the ultimate keeping quality of the fish. Fish for smoking can be prepared as whole fish (either gutted or ungutted) or split, filleted, in chunks or slices, etc. Here again, local tradition and preference will decide.

1. If required, pre-salt the fish for at least 10 to a maximum of 90 minutes in a brine of six parts water to one part salt. The time required will depend upon the size of the fish, its preparation (whether split, filleted or whole) and its degree of fatness (a fatter fish needs longer brining) and can be determined more exactly by experimentation. If the fish are not pre-salted they should be washed.
2. Hang the fish from a stick or lay them on a mesh tray taking care that they do not touch each other. If the fish are placed on a mesh tray they may be turned during the process for more even smoking. The fish can be hung in different ways. Whole fish can be hung on a stick threaded through the gill covers, or by a string tied around the tail. Split fish can be hung with a string around the tail or with an S-shaped hook through either the head end or through the tail. If split fish are suspended through the head end, it is an advantage to have the gill bone left in place, as fish flesh can tear under its own weight.
3. Build a fire in the firebox. At the beginning the fire should be smouldering, to dry the surface of the fish. The temperature should then be increased, by allowing in more air. This phase should last about two hours and will cook the fish. If the initial drying is not carried out properly the flesh will cook too rapidly and the fish will fall from the sticks or break up on the trays. After cooking, drying should be continued for several hours at a lower temperature. This would be in the sun, if climatic conditions are favourable, but the fish must be covered with mosquito netting or gauze to prevent infestation by flies and beetles. The finished product should have the consistency of rough wood and should be thoroughly dry. Mould growth will rapidly result if any parts of the fish are not properly dried.
4. This product, if protected from insect infestation, will keep for several months. Under humid conditions it can be packed in airtight containers or heavy-gauge polyethylene. Otherwise, if this is too expensive, it can be redried from time to time.

SUN DRYING OF FISH

For best results split medium or large sized fish but a salted, gutted, whole fish can also be dried. Use smoked fish, non salted or salted fish (but rinse this in boiled water.)

Place the fish on mesh, bamboo or other trays that will permit free circulation of air. Keep in the shade for the first day or two (depending on the humidity) If the fish is put straight away into the sun a crust will form which will hamper drying. When the surface begins to appear dry then put the trays in the sun. During the night cover the fish with plastic sheeting.

when the fish is ready it will not bend easily. Non salted dried fish and salt dried fish will keep for a long time if stored in earthenware pots.

SUN DRYING OF FRUIT & VEGETABLES

It is possible to preserve acid fruits and vegetables such as **tomatos** by bottling them under pressure in Kilner or Mason jars. Annexure **No. 7** " A Manual of **Food Preservation** " sets out this process in detail.

Fruit and vegetables **can** also be sun dried to preserve them but they must be of good quality, freshly **har-**vested and ripe. Damaged or dirty fruit or vegetables will spoil.

They should be washed in boiled water and, after trimming, cut up into slices.

Vegetables such as okra, carrots and green beans should be blanched. To do this place them in a square piece of clean cloth, tie the corners together, push a stick through and suspend this bundle in boiling water for about six minwtes. Then take it out end place it in cold water.

Spread the fruit or vegetables out on drying trays or a piece of plastic sheeting and turn every hour or so. Do this as soon as possible after slicing the product or it will **discolour**.

The length of time needed to fully dry the product will depend on the strength of the sun but is usually **24 hours..**

CREEP FEEDERS FOR
BABY CHICKS

KEEP THE BIG
CHICKENS OUT

POULTRY

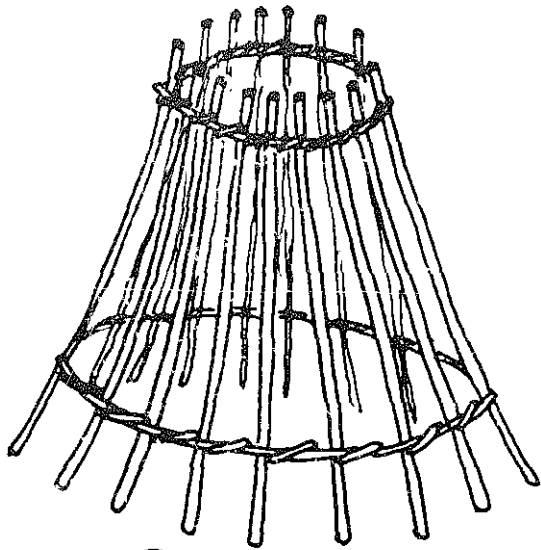
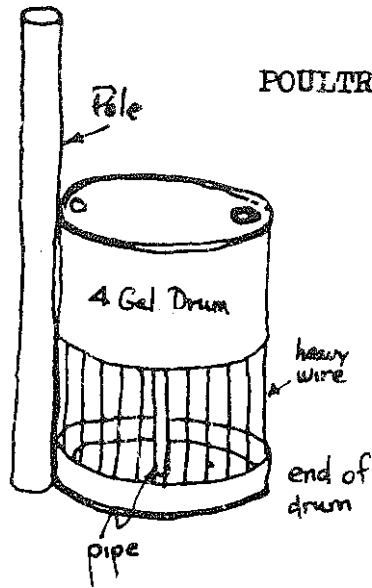

Ptpit or Bamboo

If the food for the very small chicks is put inside either of the containers shown above, they can get through the bars hut the bigger hens cannot do so and can not, therefore, take their food.

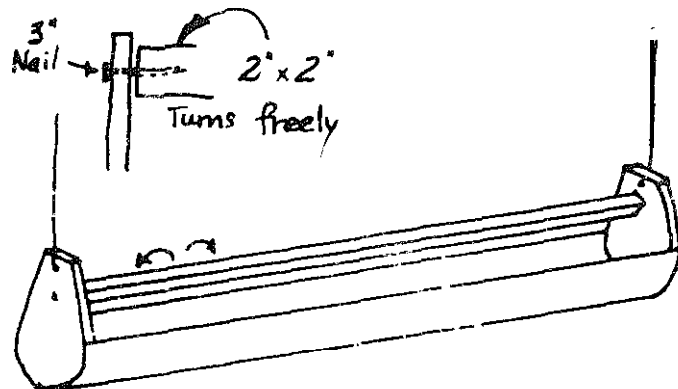

HANGING POULTRY FEEDER
prevents chickens from standing
in feed.

POST HARVEST ACTIVITIES

1.

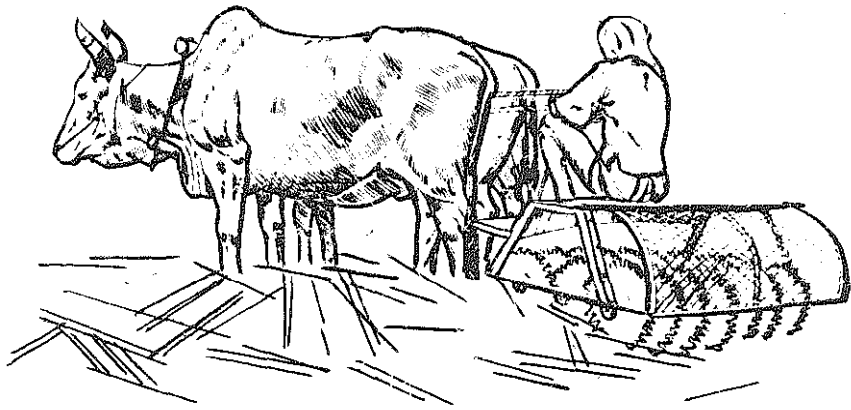

- Olpad thresher, made in India on the pattern of the Egyptian Norage thresher; diameter of disks about 45 cm. disk spacing 15 cm. number of disks 20

THRESHING

STONE ROLLER 2.

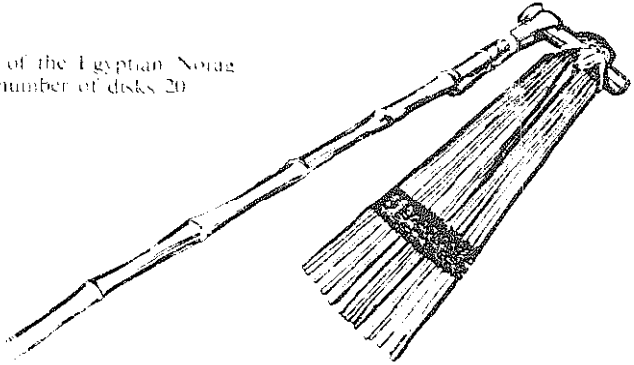
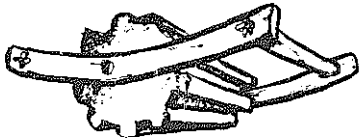

CHINESE FLAIL 4.

3.

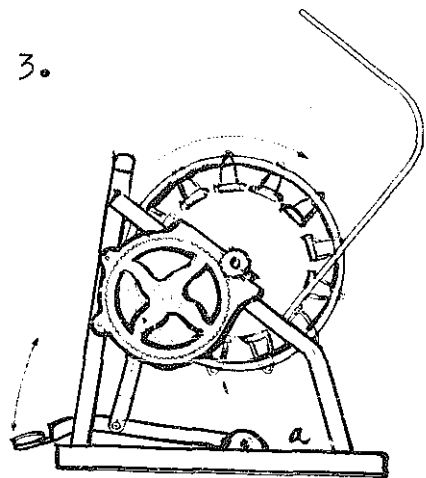

5.

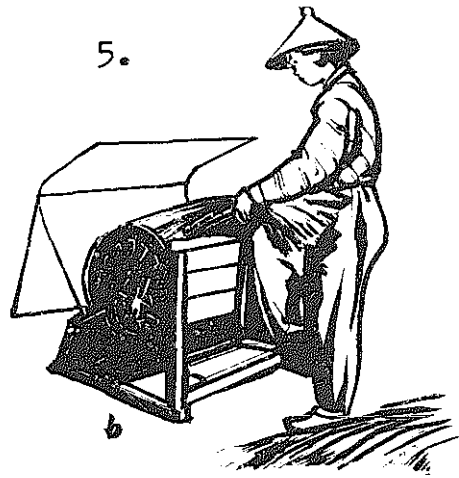

- Japanese rice thresher: (a) sectional view of rice thresher; (b) rice threshing with a pedal-operated machine.

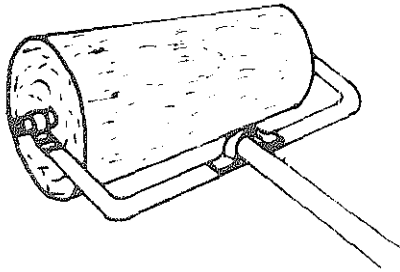

STONE THRESHING ROLLER

This threshing roller is tapered so that it can easily be pulled round in circles over the crop by the animals.

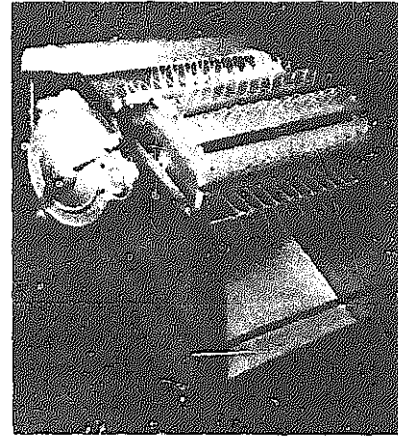

ROTARY THRESHER

This is a pedal operated thresher running on ball bearings. The sheaves are held against the rotating drum, which is fitted with wire teeth, and the grain is threshed out.

Weight 46.5 kg.

Threshing capacity 650 to 850 kg per day.

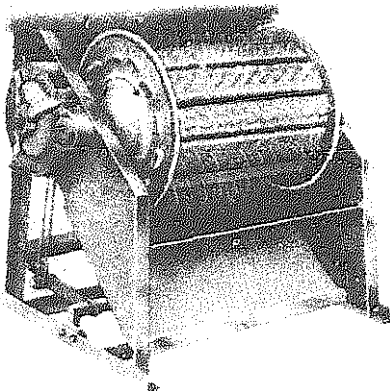

AKSHAT AK-51 ROTARY PADDY THRESHER

Pedal Driven

Threshing is done by holding paddy sheaves in suitable bundles close to teeth on the rotating cylinder and the cylinder is kept in motion by pedalling. The grains are thus separated or combed out from ears by wire teeth on spokes of cylinder.

Specification

Machine working in 5 ball bearings ensures smooth running, easy operation and high efficiency. Angle iron frame and base covered with steel sheets, simple but strongly built mechanisms easily accessible for servicing.

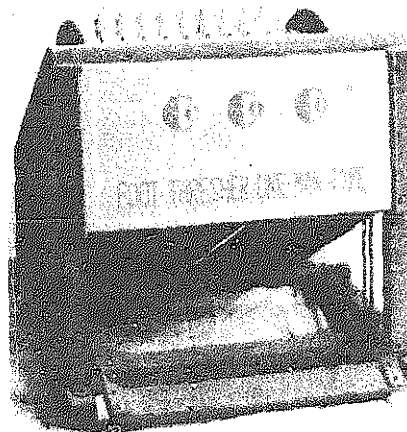

CECOCO LIGHT FOOT THRESHER

Designed for threshing rice.

Wire threshing teeth are fitted in the rotating drum, which turns at approximately 450 rev/min when the treading rate is 90 strokes per minute.

Threshing rate 115 kg per hour.

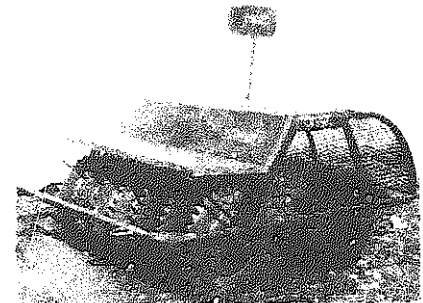

OLPAD THRESHER

This machine has serrated discs of 450 mm (18") diameter. The frame is of angle iron. The discs are mounted on a steel shaft. Cast-iron spools keep the discs in position. A comfortable seat is provided for the operator with a back rest and foot rest. Back and front safety guards eliminate risk of injury to the operator. The harvest is spread on threshing floor and the machine is drawn round a and round thus separating grain. A" extraraking attachment can be fitted for stirring straw during threshing operation. This thresher is available in 20, 14, 7 and 8 disc sizes.

Weight: 20 Disc 190.0 Kg.

14 Disc 125.0 Kg.

11 Disc 110.0 Kg.

8 Disc 92.1 Kg.

Threshing rate: 350 to 850 Kg. according to size in day.

An overhead
animal power gear

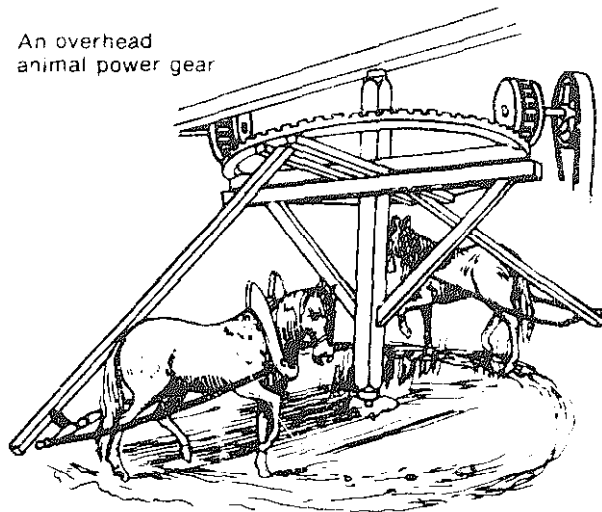

1.

ANIMAL POWER GEARS

2.

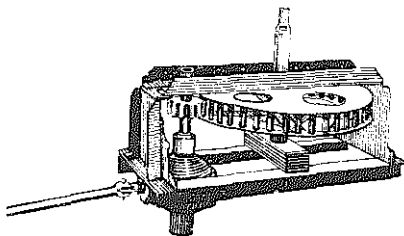

BULLOCK GEAR

This mechanism converts the power of bullocks walking slowly round in circles into high speed rotary motion of a shaft. This shaft can be used to drive any stationary machines.

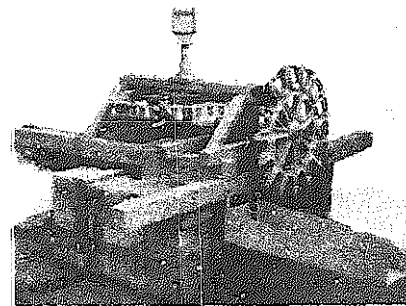

3.

ANIMAL-DRAWN CHAIN PUMP

This pump is capable of lifting water from a depth of 40 ft (13 metres). Since the diameter of the chain wheel is small, the pump can be installed in wells whose diameter is as small as 3 ft (1 metre). The pump also has the advantage that the gearing is low. The pole drive from the main gear to the animal can be taken direct and does not have to be carried underground. The rubber washers are replaceable. Weight of the pump is 840 lb (380 kg), and the output is 3000 to 4000 gal/hr (13,500 to 15,000 litres per hour).

1.

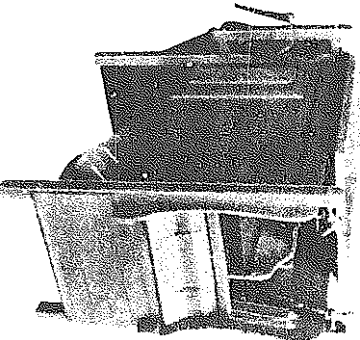
**No. 8 WINNOWER**

This is a hand powered machine constructed mainly of wood, but with metal moving parts and an oscillating bottom screen. It is fitted with five 40 cm x 40 cm metal sieves for the efficient screening of all kinds of grain including wheat, barley, and maize.

2.

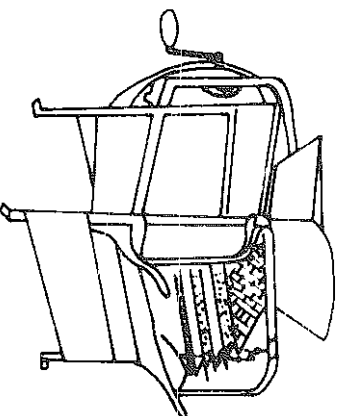
**WINNOWER**

Air draught controllable, sieves replaceable. Runs on four ball bearings.

4.

3.

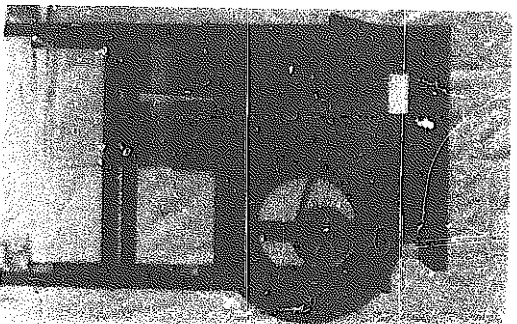
**HAND GRAIN WINNOWER TYPE A1.**

All steel construction.

Three separate outlets for first quality clean grain, second quality grain and chaff.

Capacity 650 kg. grain per hour.

Weight 30 kg.

2.

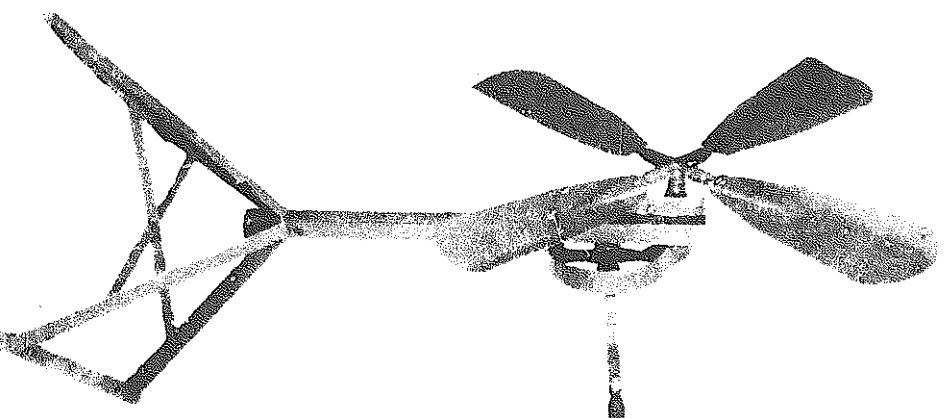
**HAND WINNOWER**

This is a cheaper version of the cycle winnower. Two people can winnow in front of it.

Weight 25 kg.

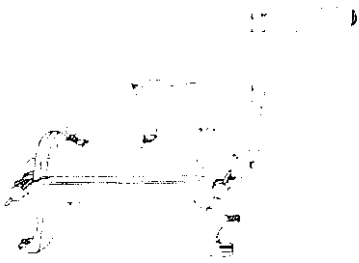

JAVA HAND-POWERED RICE HULLER

This is a small machine intended for the grower of small quantities of rice paddy, and for domestic use. It replaces the *Paddy Pounder*. Paddy can be shelled at a maximum rate of about 30 lb (14 kg) of paddy an hour, but the capacity may vary considerably depending on the type of paddy and its condition. The machine has three adjustments controlling the feed, the discharge and the hulling knife. A perforated plate allows dust to escape, and the machine can be opened easily for cleaning. Strongly made, it weighs 23 lb (10.5 kg) net and is provided with holding-down screws and spanners.

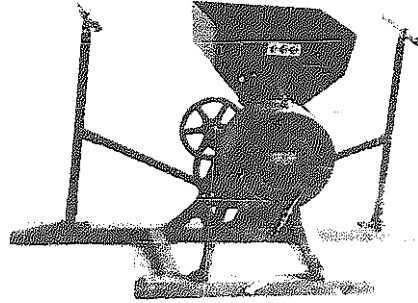

TWO MAN RICE HULLER

Two men pull the hand levers and rotate the huller at 3,500-4,000 rev/min.

Output 250 kg/hour at 90% hulling efficiency.

Weight 60 kg.

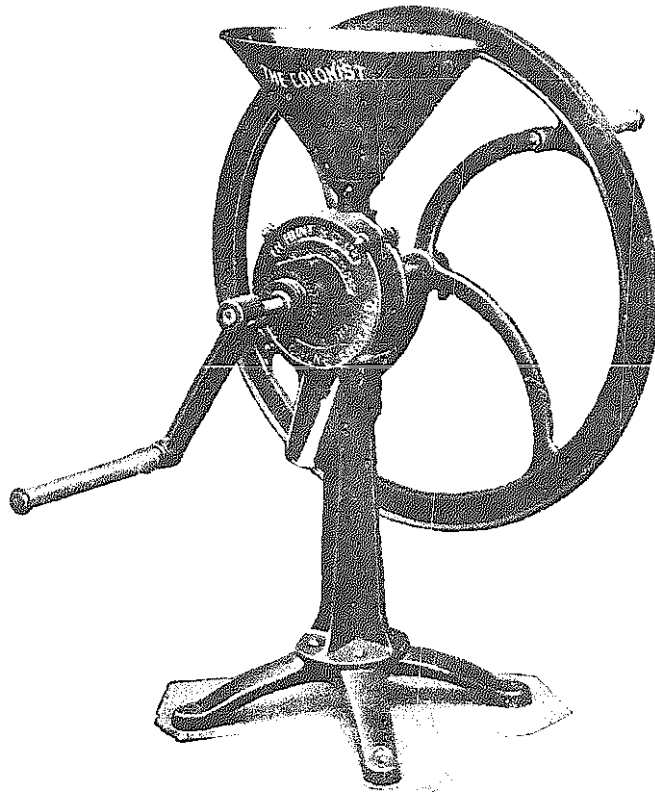

This grinding mill is turned by two people, it is a large mill (some 4 feet high) and strong enough to stand up to being used continually by many people. It will grind, maize, wheat, coffee, millet etc.,



Chinese straw cutter
(Shansi Province, Mainland China), with
iron teeth to prevent straw slipping.

1.

2.

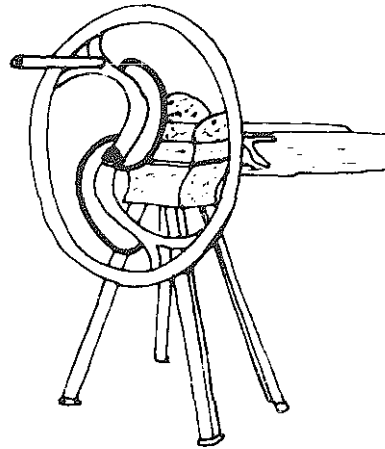

HAND CHAFF CUTTER

This implement is used to cut chaff into
pieces approximately one inch (25 mm)
long.

Straw cutters - for animal feed.

3.

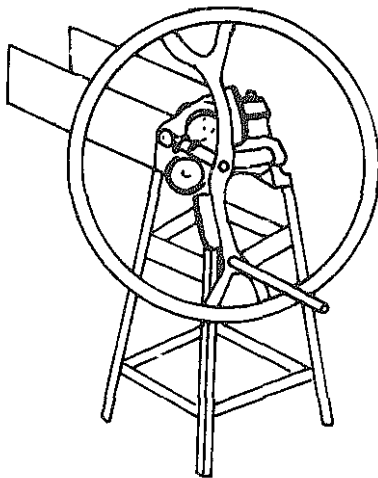

CHAFF CUTTER

All cast iron flywheel type, manually
operated. Runs on two ball bearings.

4.

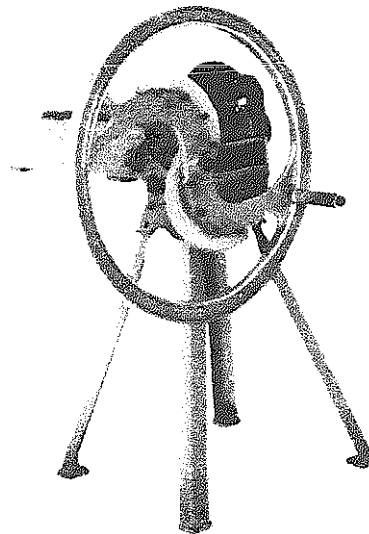

SIMPLEX CHAFF CUTTER

Hand powered implement.
Power driven models also available.

1.

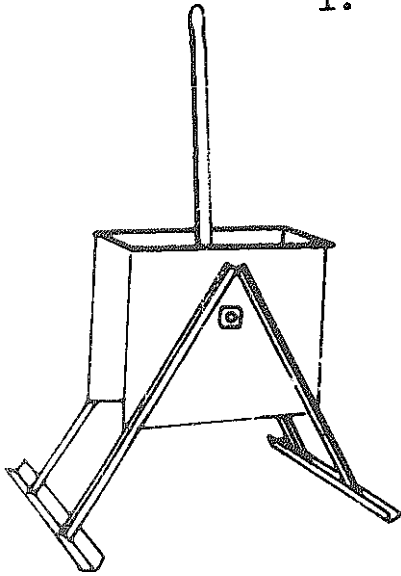
**GROUNDNUT SHELLER**

2.

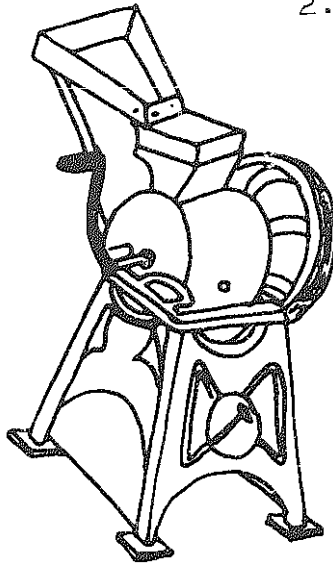
**HAND OPERATED GROUNDNUT DECORTICATOR**

3.

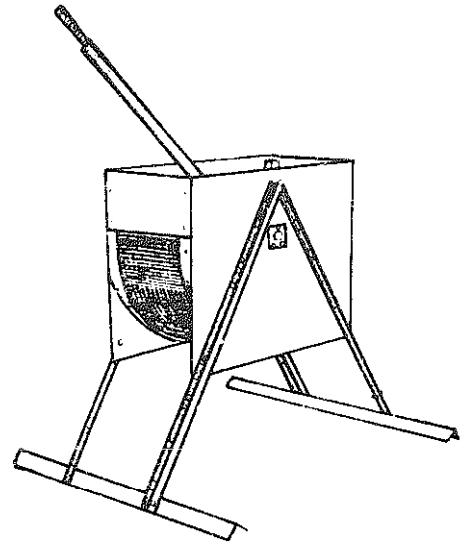
**GROUNDNUT DECORTICATOR**

This hand operated decorticator uses galvanised, heavy gauge wire mesh for a screen. The distance between the screen and the rubbing bars can be adjusted to suit the type of groundnuts being decorticated. Four different sizes of screen can be supplied.

4.

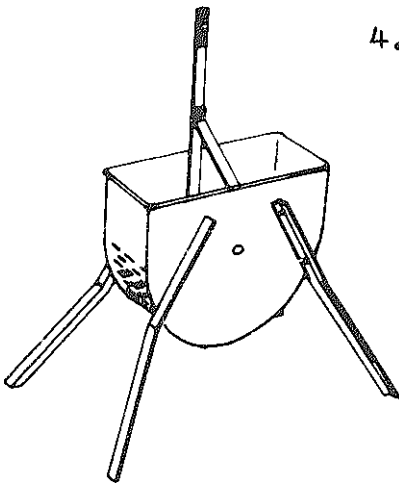
**"HANDY" GROUNDNUT DECORTICATOR**

Nuts to be shelled are placed in the receptacle and the operating handle is then moved backwards and forwards. This causes the nuts to be rubbed between the spiked cast iron rustlers and the shelling grid which forms part of the outer casing. The nut kernels and broken shells fall through the perforations in the shelling grid to the ground. There is no facility for separating the shells from kernels.

5.

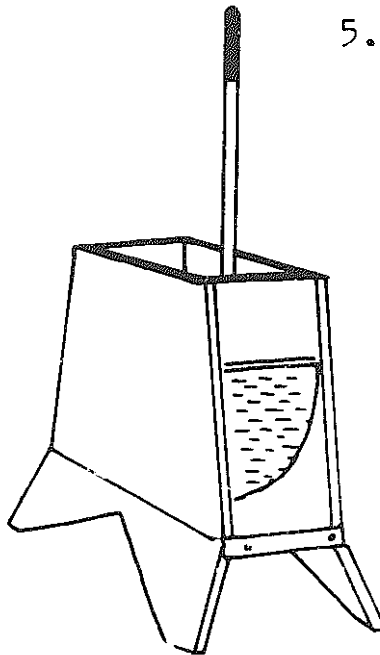
**ALTERNATING HUSKER**

This is a reciprocating hand-operated groundnut decorticator fitted with a pressed screen with oblong holes. Screens can be supplied to give six different sizes of hole.

6.

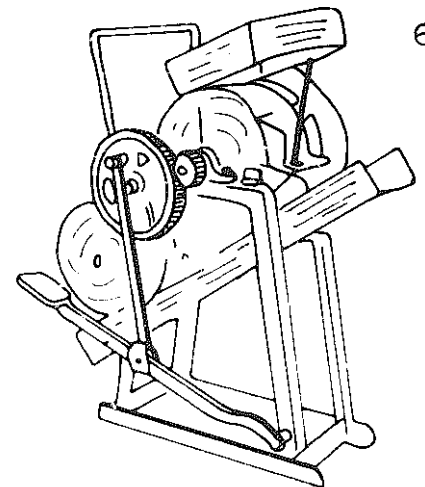
**FOOT OPERATED GROUNDNUT SHELLER**

Fitted with a flywheel for easier operation and with a blower to separate the shells from the kernels.

The machine can be operated and fed by one person and can shell 200 kg in an 8 hour day.

PEANUT SHELLER

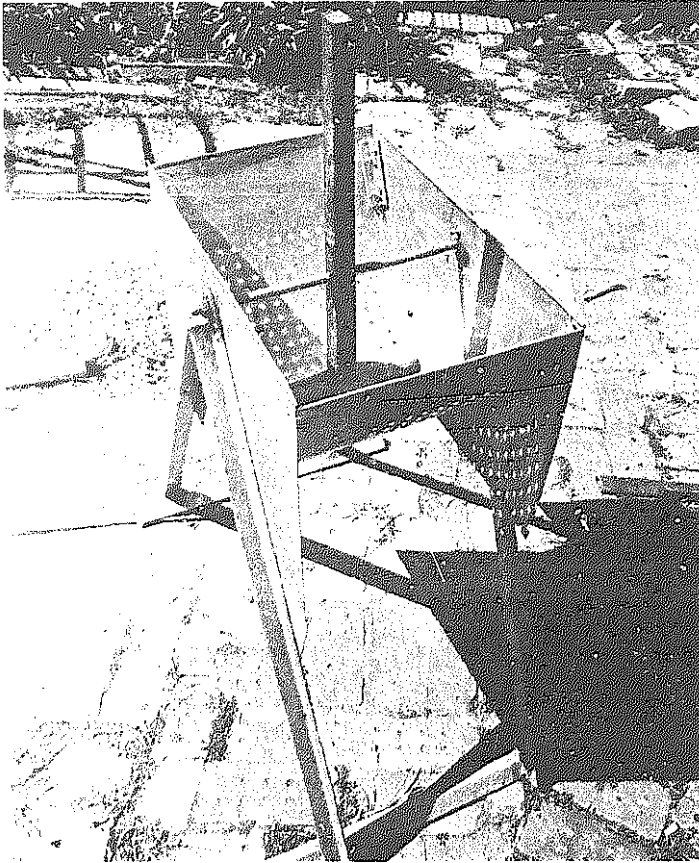

This peanut sheller was built in Bangladesh by a group of women of the Gonoshasto Kendro Workshop in Savar.

The peanuts are put into the machine, the "roller is pulled backward and forward and the shelled peanuts pour through the holes into a receptacle put underneath.

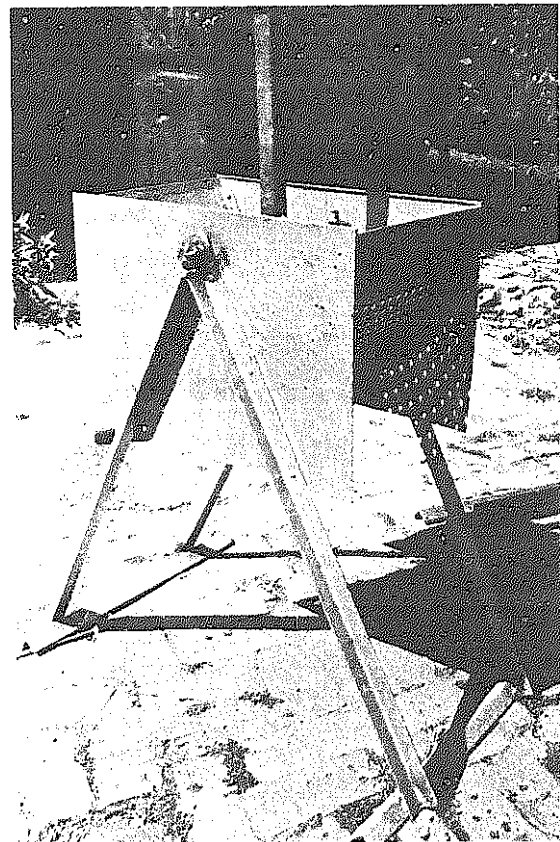

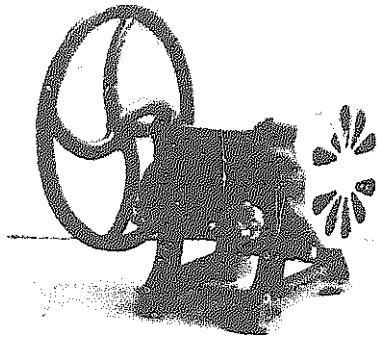

HAND SUGAR CANE SQUEEZER

3 roller pattern.
Capacity 115 kg/hour of cane.

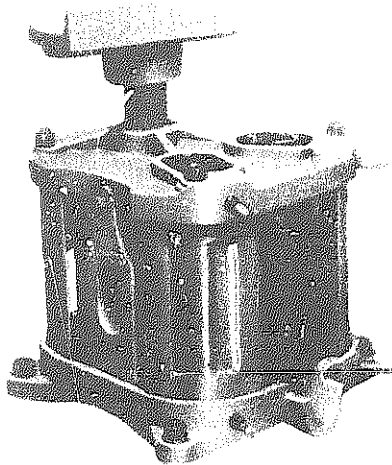

KUMAR CANE CRUSHER

This is a vertical three roller sugarcane crusher which can be driven by one pair of animals.

Crushing capacity 300-350 lb/hour (136-158 kg/hour)

Also available *KARAMAT* and *KAMAL* vertical three roller crushers with higher capacity.

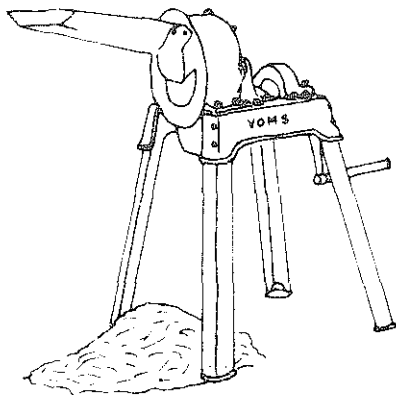

VOMS HAND PALM NUT CRACKER

This simple machine is turned by a handle and has an output of 150-200 kg/hour with 95% of the nuts being cracked.

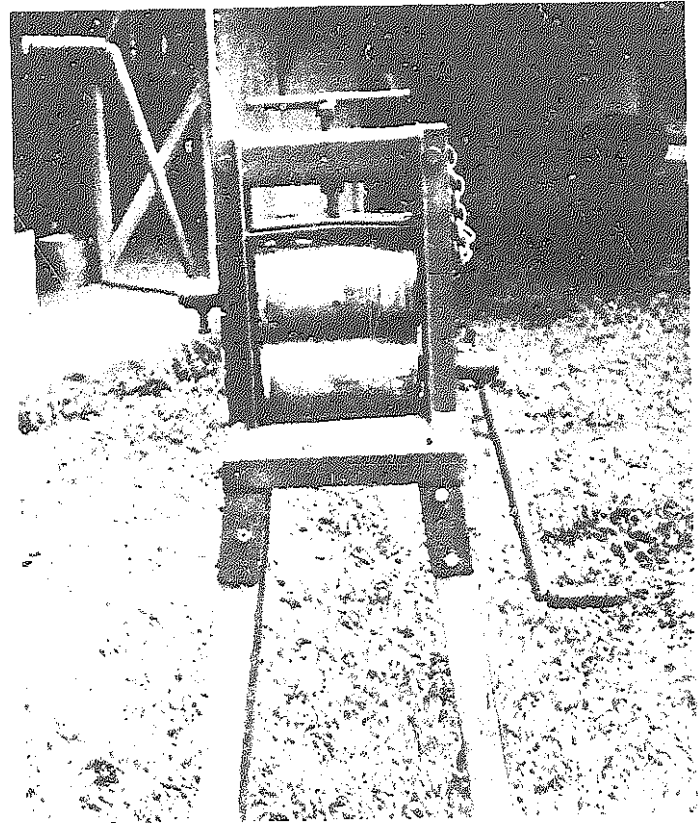

SUGAR CRUSHER

This is a simple 2-man sugar crusher without gears. It can easily be fabricated if you have access to a welder and cutting torch.

Sugar cane is passed j or 4 times, with adjustment screw on the top tighter each time.

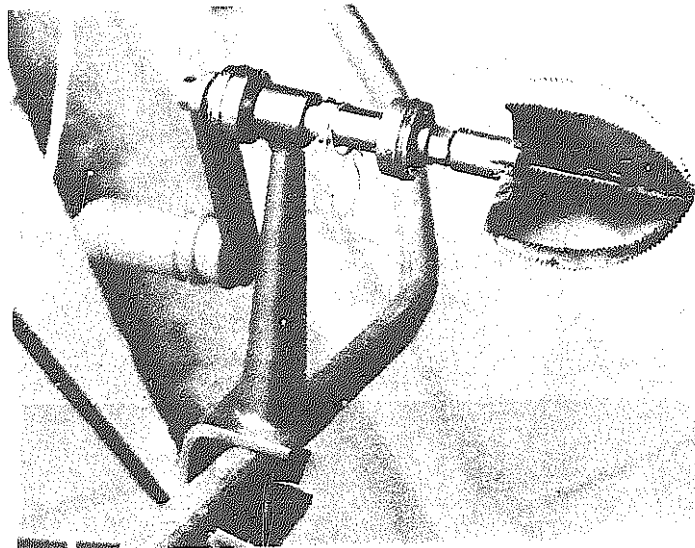

Coconut scraper, using front axle and bearing of bicycle wheel.

GRAIN STORAGE

A great deal of **grain** is spoiled now through faulty storage techniques, The illustrations on the next page show how to build a mud storage hut to protect the grain from rats, as well as from flooding,

Choose a place where the ground is firm, mark a square out and knock in four forked poles, one in each corner. Round each pole fasten a circular **,or** Conical and tight fitting piece of tin, as shown in the illustration also, this will prevent rats from climbing up the hole into the hut.

Lay four strang poles horizontally across these up - right poles, placing them in the **forks**, so that a hollow square is formed, then lay bamboos across this to make a floor and then plaster this over with mud. As this will be three feet above the ground it should be above normal flood water and it **can**, of course be made higher than this.

Build up the walls in the same **way** as is done for a house, out of mud and bamboo **and** put a flat, mud and bamboo roof on top. Do not keep old baskets, sacks etc, on this roof though or they will attract insects.

Leave a small **opening** in one wall, near the top (about two feet square) so that the grain can be put inside and, when this has been done, seal it up tightly with mud and bamboo. In the same wall, but down near the bottom, put two large empty tins such as those in which baby food is sold, with lids, but first cut the bottoms out. These tins should. be lying on their sides **,with** the lid end facing **outwards**. When it is desired to take any grain out of the store when the lid is taken off these tins the grain will run out into a basket.

Cover the completed storage hut with a thatch **roof, sup-**ported on separate poles and wider than the hut **,so** that the sun and rain will not strike the walls. Be sure that the grain is really dry before putting it in,

Grain store of mud and bamboo

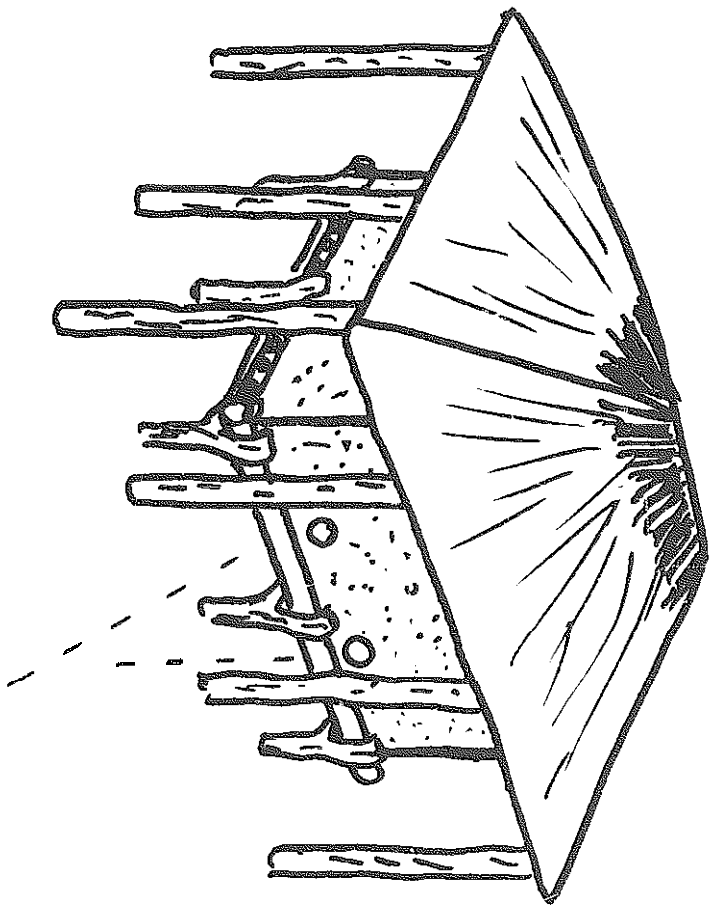

Double roof

tins inserted in wall

Forked pole at corners

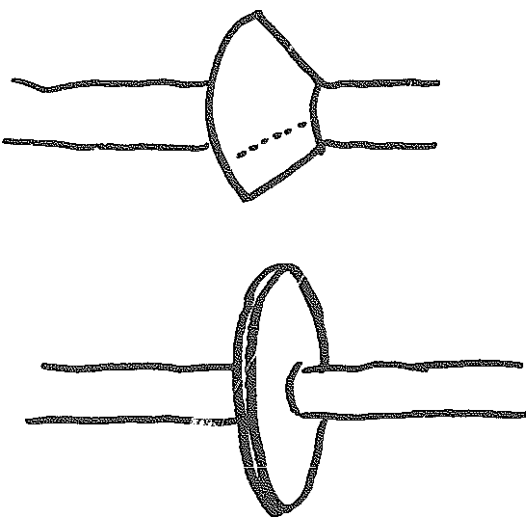
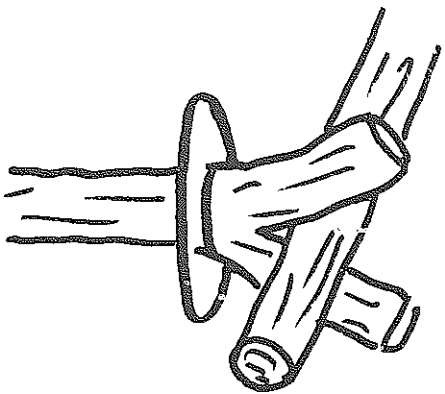

Method of preventing rats climbing up the poles

WATER

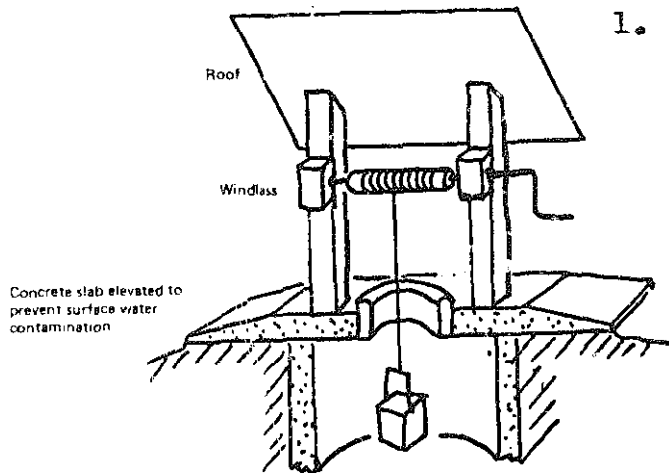

Well fitted with a windlass to lift the water.

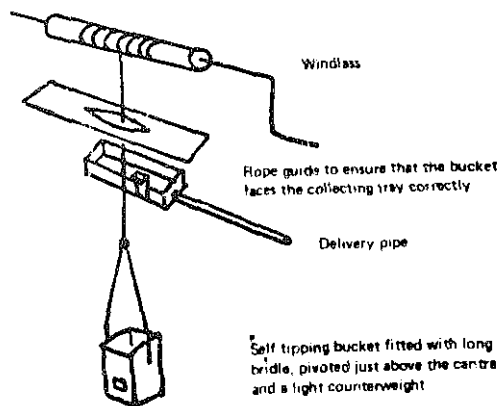

A modification which can be fitted to a totally enclosed well head or may be adapted to deliver directly to a head tank.

A windlass, this will also help to prevent the rope from fraying.

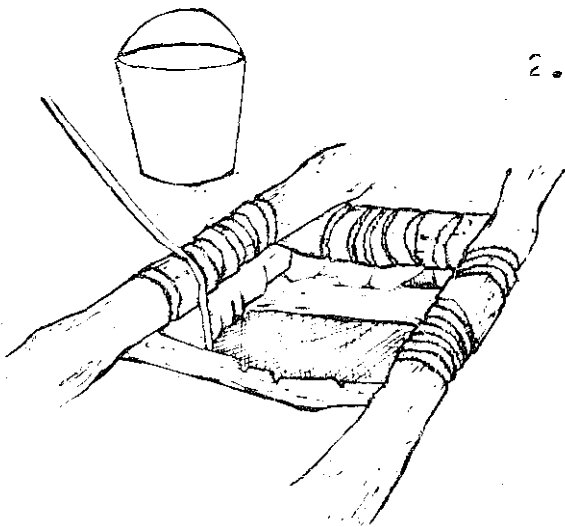

Way of saving the edges of the well from being damaged by the rope.

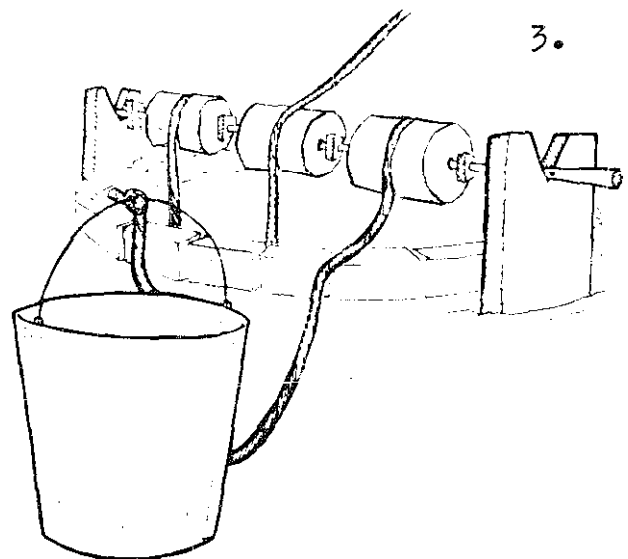

IMPROVEMENTS TO WELLS

Picture 1, on the opposite page, shows a well in soft earth with stones packed round it, These could be bricks in Bangladesh.

the bamboos round the well hole help to prevent the sides being damaged by the rope used to draw the water up and the cover keeps the water clean. The pipe sticking out, which can be of bamboo, helps to drain off the spilt water so that it is not muddy round the well.

Picture 2, shows an improved well which has been fenced in to prevent animals getting too close to it and fouling the ground round it.

Picture 3 shows an improved version in which the waste water is allowed to flow into a small tank from which the animals can drink. This well has also been fitted with a means of winding the bucket up and down so that drawing the water up is much easier. If the same bucket is used all the time the water is less likely to be contaminated.

Wells can also be fitted with hand pumps, such as those shown on pages 33, 34, and 35. This has the advantage that the well can then be covered over which will prevent rubbish being dropped in to the well.

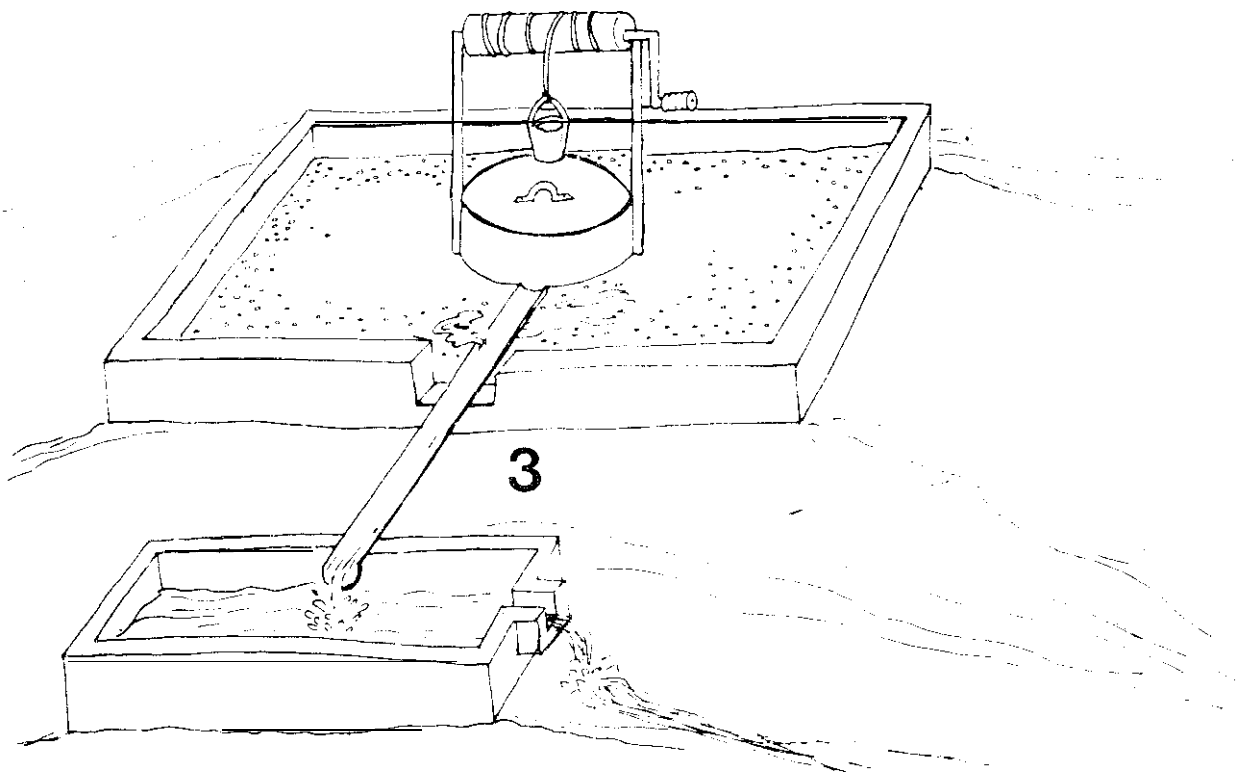
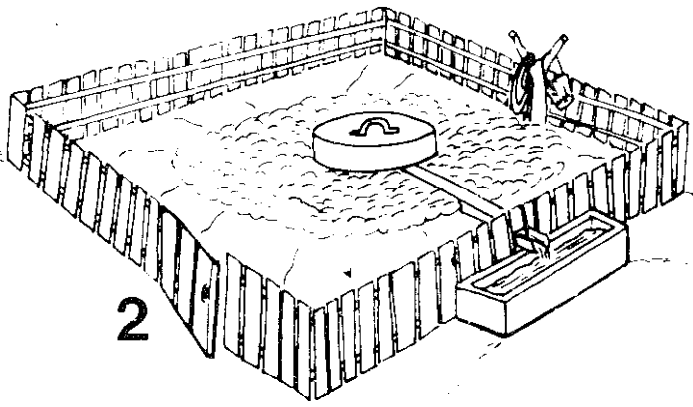
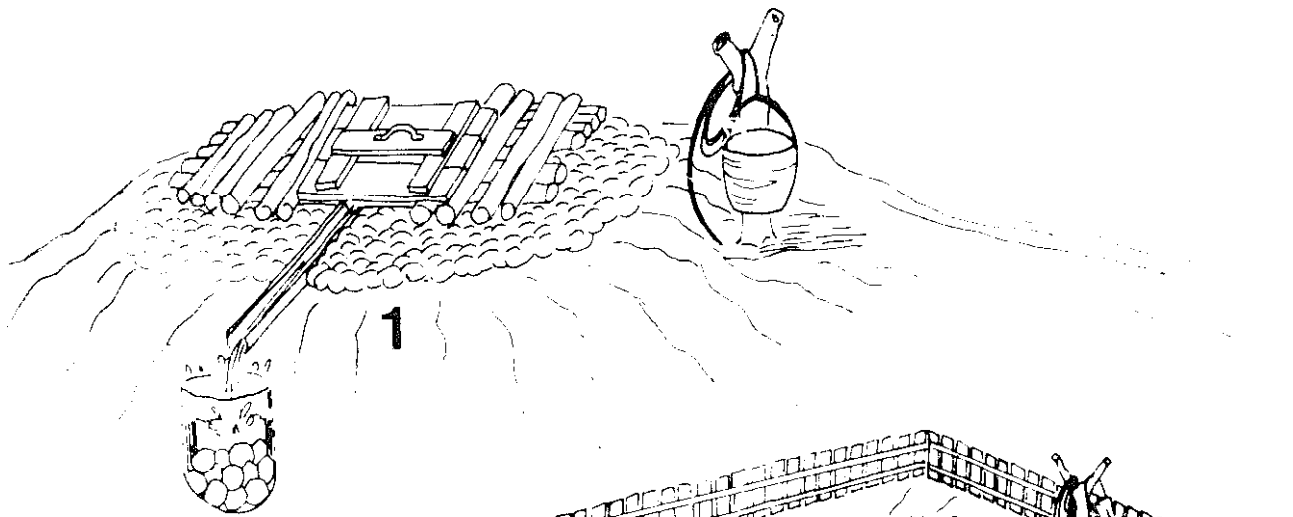

THE SHADUF

2.

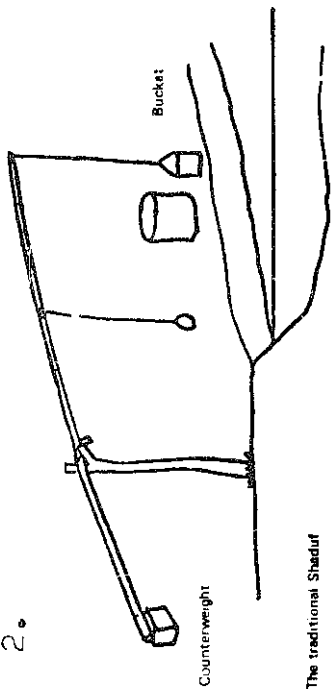

The traditional Shaduf

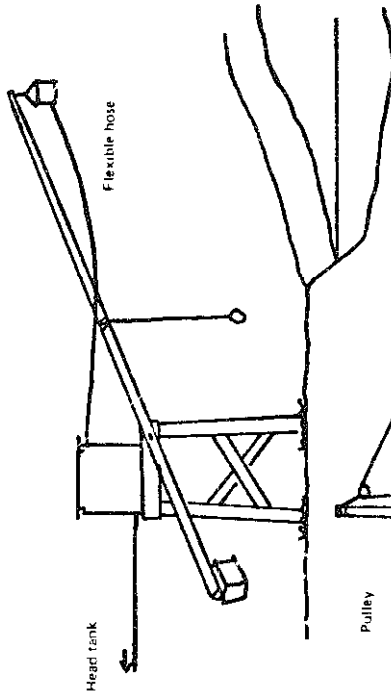

Pulley

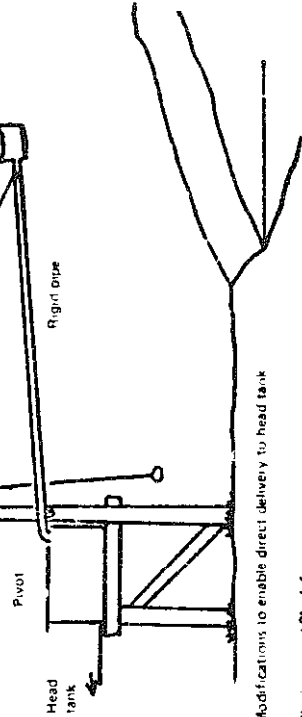

Modifications to enable direct delivery to head tank

The improved Shaduf

THE ROPE LIFT

1.

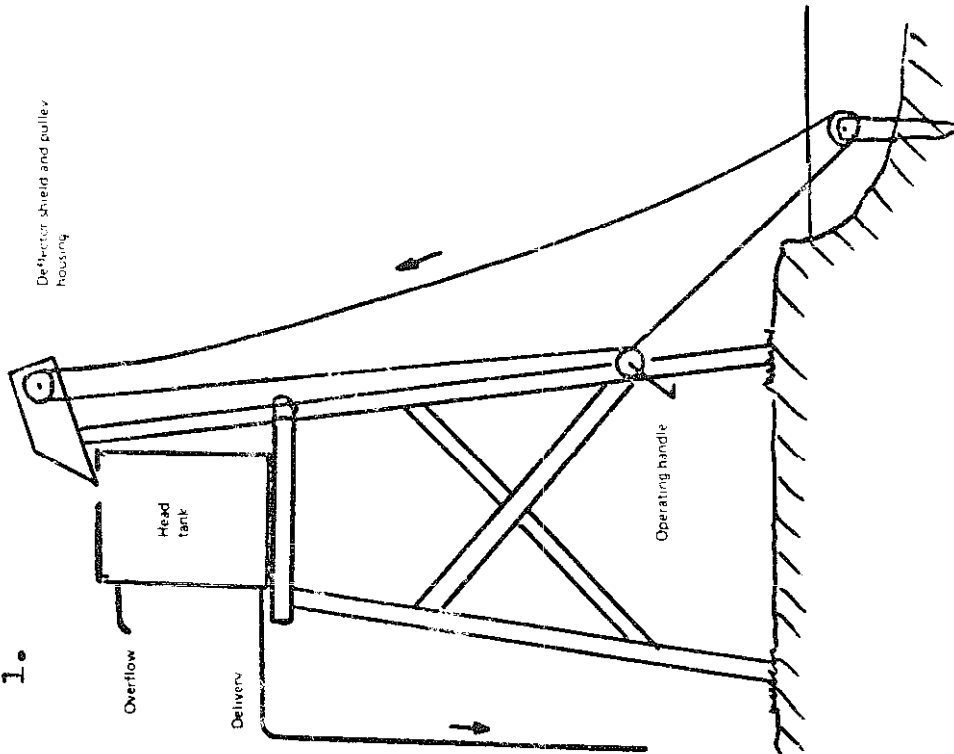

1

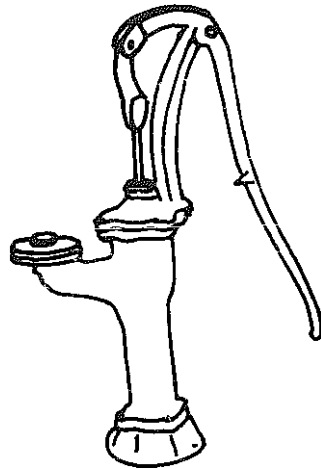
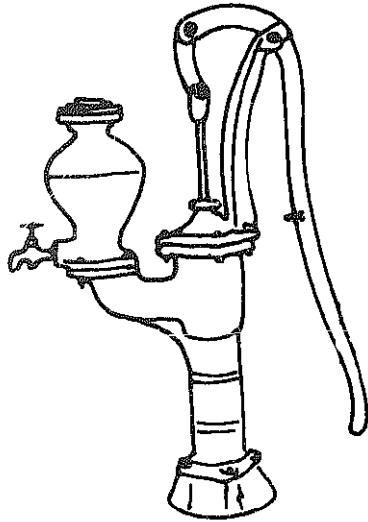

HAND PUMPS

3

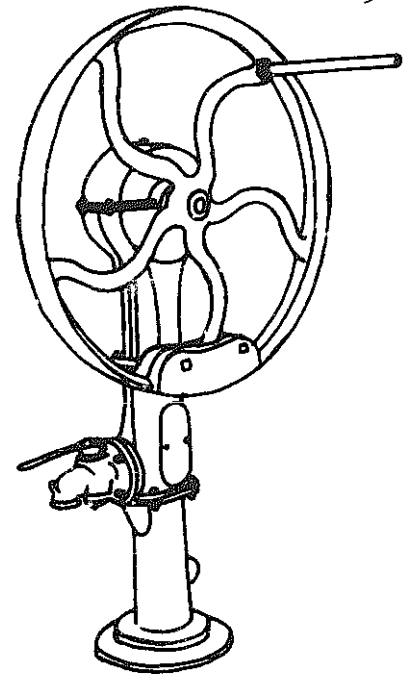

CLIMAX HAND PUMPS

This pump is suitable for deep wells up to 100 ft (30 metres), although pumps fitted with a fly-wheel and operated by two men can work to greater depths. The pump consists of a suction pipe, brass foot valve and strainer. Within the pipe is fitted a rod and valve which can be withdrawn for maintenance when required. The diameter of the suction pipe varies from 2.25 in (5.7 cm) to 4 in (10.16 cm) and the output depends on size of pipe and lift.

4

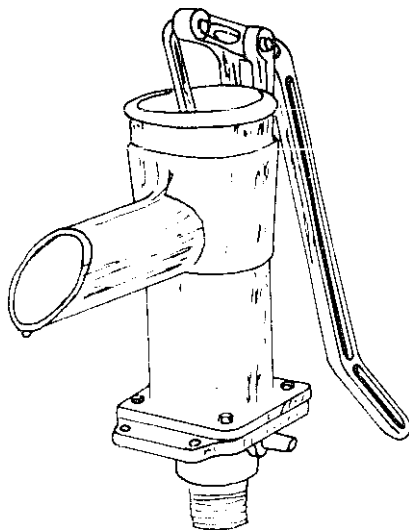

GRILLOT PISTON PUMP

Available with piston diameters 70 mm, 80 mm, 90 mm, and 100 mm.

5

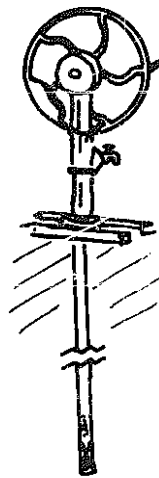

OASIS HAND OPERATED BORE HOLE PUMPS

Suitable for total heads up to 60 m with one hand wheel or 120 m, with two hand wheels fitted. Delivery 350 - 1,200 litres/hour.

6

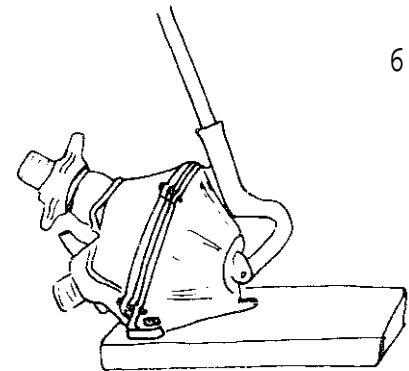

DIAPHRAGM PUMP

Output 3m³/hour (13,000 litres/hour)
Outlet diameter 40 mm.

1

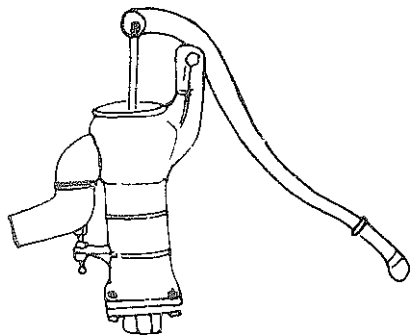
**TOMOE No. 5 PUMP**

Inside diameter of suction pipe 32 mm
Capacity per hour 2,700 litres
Suction lift 8.2 m
Weight 9.5 kg

2

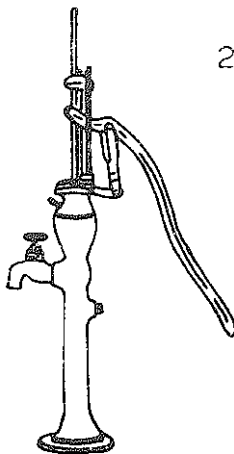
**JAL JAVAHAR PUMP**

Lift and force pump with 150 mm stroke

3

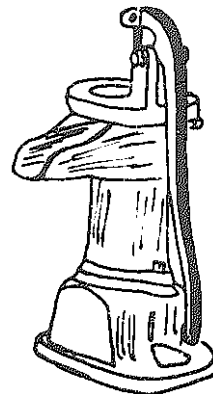
**PITCHER SPOUT LIFT PUMP**

3 inch (80 mm) diameter barrel
1 inch (25 mm) or 1/4 inch (32 mm) diameter suction pipe.

4

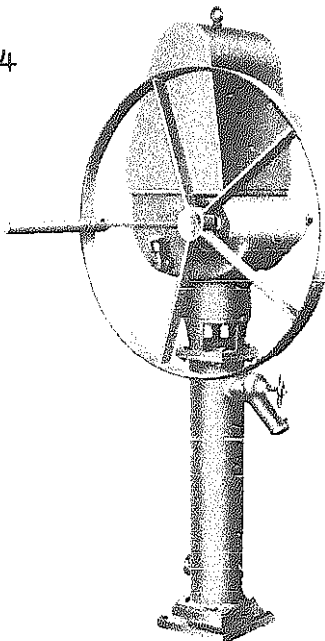
**GODWIN X AND W1H HAND PUMPS**

Two wheel-operated hand pumps, designed for wells and boreholes exceeding 25 ft (7.6 metres). Outputs of up to 500 gal/hr (2250 litres/hour) can be obtained with maximum lifts of 320 ft (97 metres). The mechanism is totally enclosed, with oil bath lubrication, and a second hand-wheel can be fitted if required. Alternatively, the pump can be connected easily to power drive by attaching a belt to the handwheel.

5

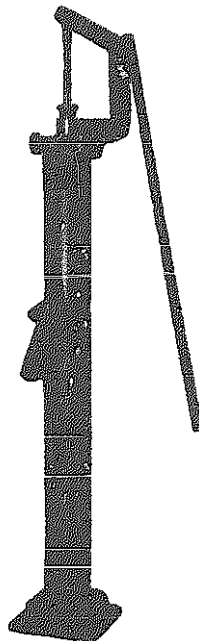
**GOODWIN HLD AND HLS HAND PUMPS**

These all-steel pumps can be supplied for lift only, or for lift and force. The HLD range is designed for boreholes exceeding 25ft (7.6 metres) deep. Outputs range up to 660 gal/hr (3000 litres). The HLS range is designed for boreholes of less than 25ft (7.6 metres) and to give outputs up to 760 gal/hr (3500 litres).

6

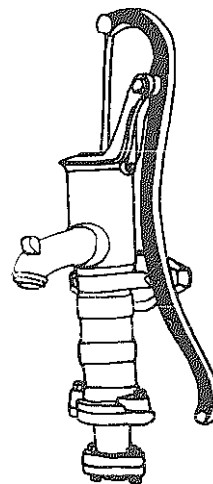
**PISTON PUMP**

Various types available with barrel diameters from 65 mm to 90 mm, giving discharges per stroke from 0.5 litres to 1.1 litres.

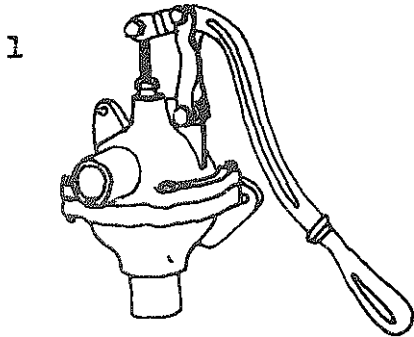

MIDGET LIFT AND FORCE PUMP

Suitable for sandy or gritty water and semi-solids. Construction either all-iron or all-bronze.

| | | | | | |
|----------------|-----|------|------|------|------|
| Size (mm) | 19 | 25 | 32 | 38 | 50 |
| Capacity (l/h) | 900 | 1600 | 2250 | 3650 | 5900 |
| Weight (kg) | 3.9 | 6.8 | 11.8 | 14.5 | 25.9 |

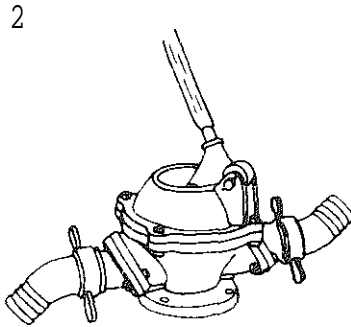

DIAPHRAGM PUMP

Heads obtainable: suction 6-7m

delivery 10-12 m

Discharge 5000-7000 litres/hour

Weight 28 kg.

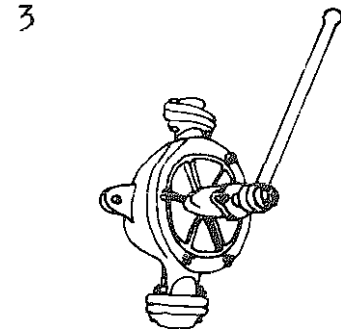

SEMI ROTARY PUMP

4

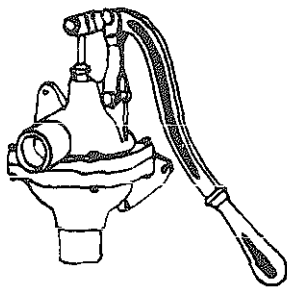

MINIATURE LIFT AND FORCE PUMP

A diaphragm pump with capacity 900-5,400 litres/hour according to size.

5

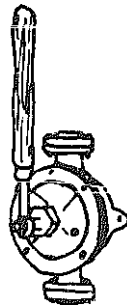

SEMI-ROTARY WING PUMP

Capacity ranges from 680 - 4,100 litres/hour according to size.

6

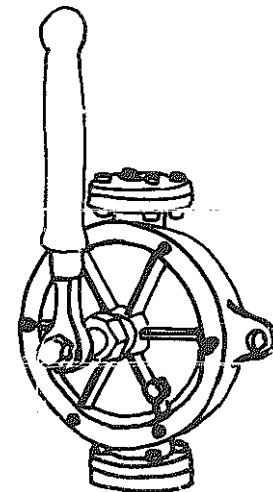

SEMI ROTARY PUMP

Suction head maximum 7.5 m (Foot valve is recommended for suction heads greater than 2 m.)

Delivery head 15 m maximum.

Available in six sizes with capacities from 1200 litres/hour to 6600 litres/hour.

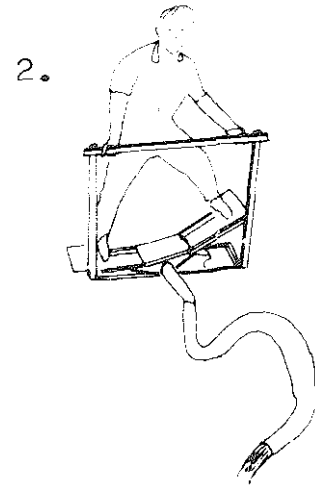
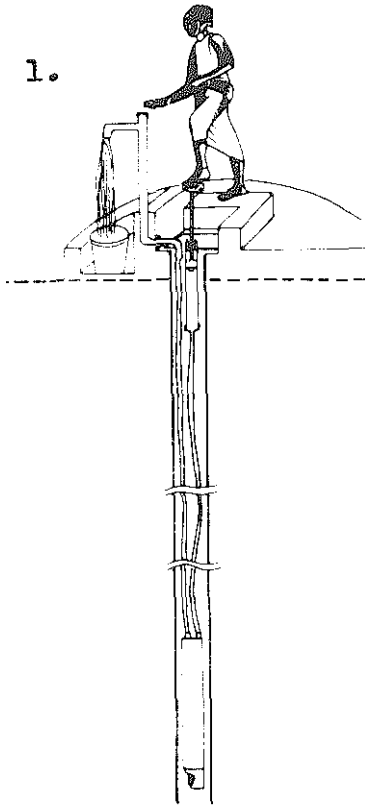

I.R.R.I. BELLOWS PUMP

This pump was designed by the International Rice Research Institute in the Philippines. It consists of two canvas bellows which are foot powered, the operator changing his weight from one foot to the other.

Capacity 150 litres/min at 0.5 m head
 " 120 litres/min at 0.5 m head
 " 90 litres/min at 1.5 m head

VERGNET HYDRO-PUMP

This pump was designed in Upper Volta for use in remote areas where maintenance facilities are limited.

A foot operated piston at the surface forces water through the "command pipe" to the bottom of the bore hole. This water from the "command pipe" causes a flexible bag to expand inside a rigid cylinder. The rigid cylinder is fitted with two clack valves and acts as the body of a diaphragm pump, the flexible bag serving as the diaphragm.

Groundwater from the bore hole is taken in through one clack valve into the rigid cylinder and forced out through the other valve, up the output pipe to the surface.

The water in the "command pipe" system does not mix with the water being pumped and remains free from sand or other contamination.

The "command pipe" can be extended horizontally at the surface, therefore the operator is not forced to stand directly above the bore hole.

The pump can be fitted into a bore hole of 10 cm diameter.

Performance:

| | | | |
|-----------------|-----------------------|----------------------|----------------------|
| Bore hole depth | 20 m | 40 m | 60 m |
| Output | 1.5 m ³ /h | 0.7m ³ /h | 0.5m ³ /h |

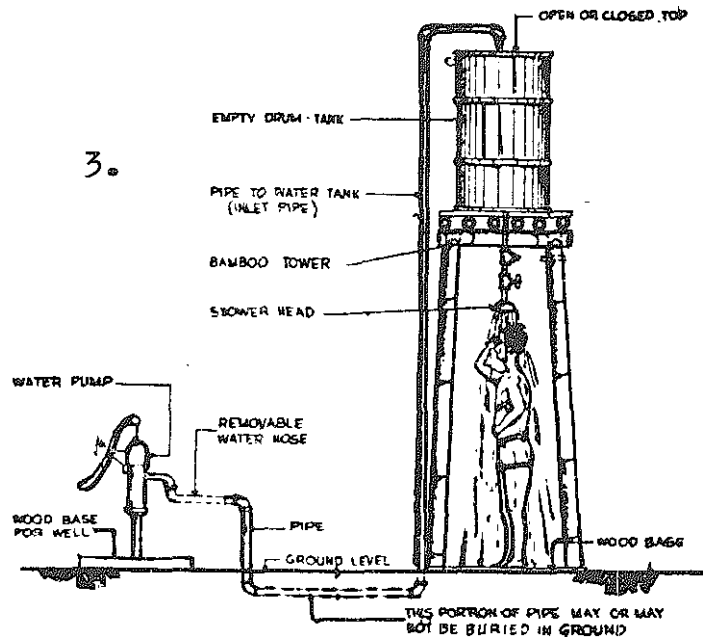

A simple type of shower worked from a hand pump,

GENERAL

AN EASY WAY TO SPLIT BAMBOO

knock two strong posts into the ground, tie two pieces of iron or two hard wood sticks to them in the shape of a cross. These should be about one inch thick. (Picture 1.)

At the top end of the bamboo make four cuts at right angles to each other.

Hold these cuts open by means of wedges and put the bamboo on the cross in the way shown in Picture 1.

Take out the wedges and push and pull the bamboo towards the cross until it splits the whole way down.

To split the bamboo again, after it has been split into four pieces, mount an iron wedge on top of one of the posts and push the bamboo against this.

Picture.

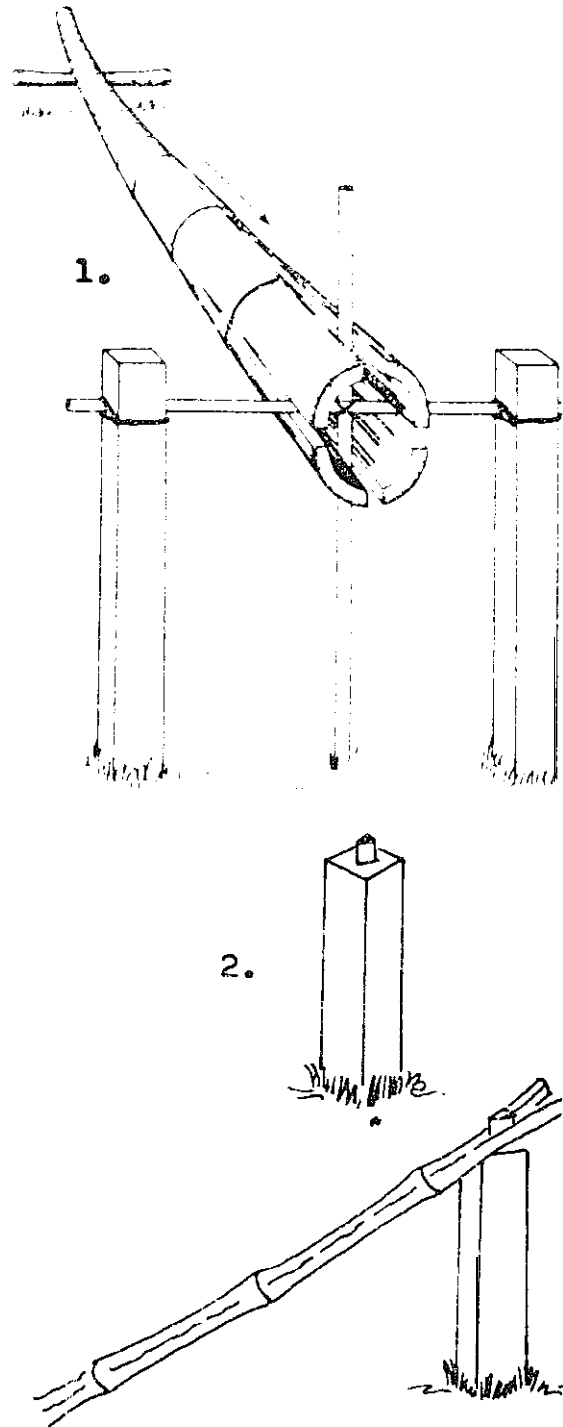

Another way of splitting bamboo,

Preserving bamboo
 To preserve bamboo mix 5% boric acid with 95% water to make BORAX. Soak green bamboo in this mixture until it has become thoroughly saturated. Let it dry before using. There may be an unpleasant smell for a week or two but this will fade.

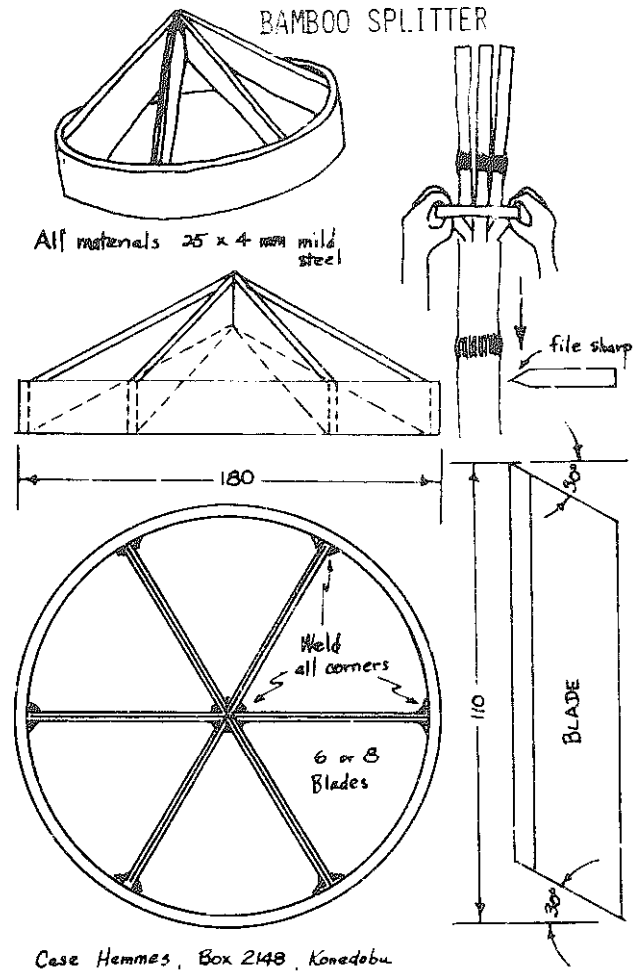

Case Hemmes, Box 2148, Konedobu.

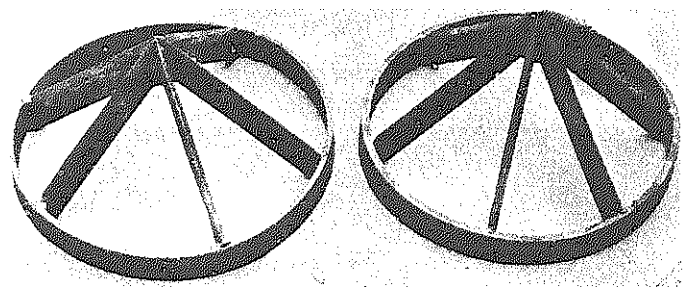

| A | B | C | D |
|--|---|---|--|
| Plant 1st year | Plant 2nd year | Plant 3rd year | Plant 4th year |
| Cut after :- 4th year 8th 12th etc | Cut after 5th year 9th 13th etc | Cut after: 6th year 10th 14th etc | Cut after: 7th year 11th 15th etc. |

FUEL PLANTATIONS

If self regenerating trees, such as certain kinds of eucalyptus are planted as shown above, the trees at A should be ready to be cut down by the end of the 4th year, B can be cut down the next year and C and D the next two years, by which time A will have grown up again and be ready for re-cutting.

In this way a supply of firewood can be assured for ever providing that the plantation is properly managed and unauthorised cutting prohibited.

PROPAGATING BAMBOO

Take four nodes from a stem about a year old. Plant near a stream or a place that will usually have plenty of water. Put into the ground at a 45 degree angle, with 2 nodes under the ground and two nodes above it. Plant several sticks in one place but not too close together.

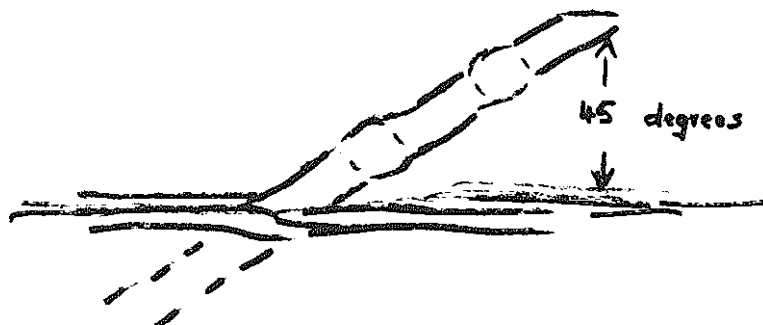

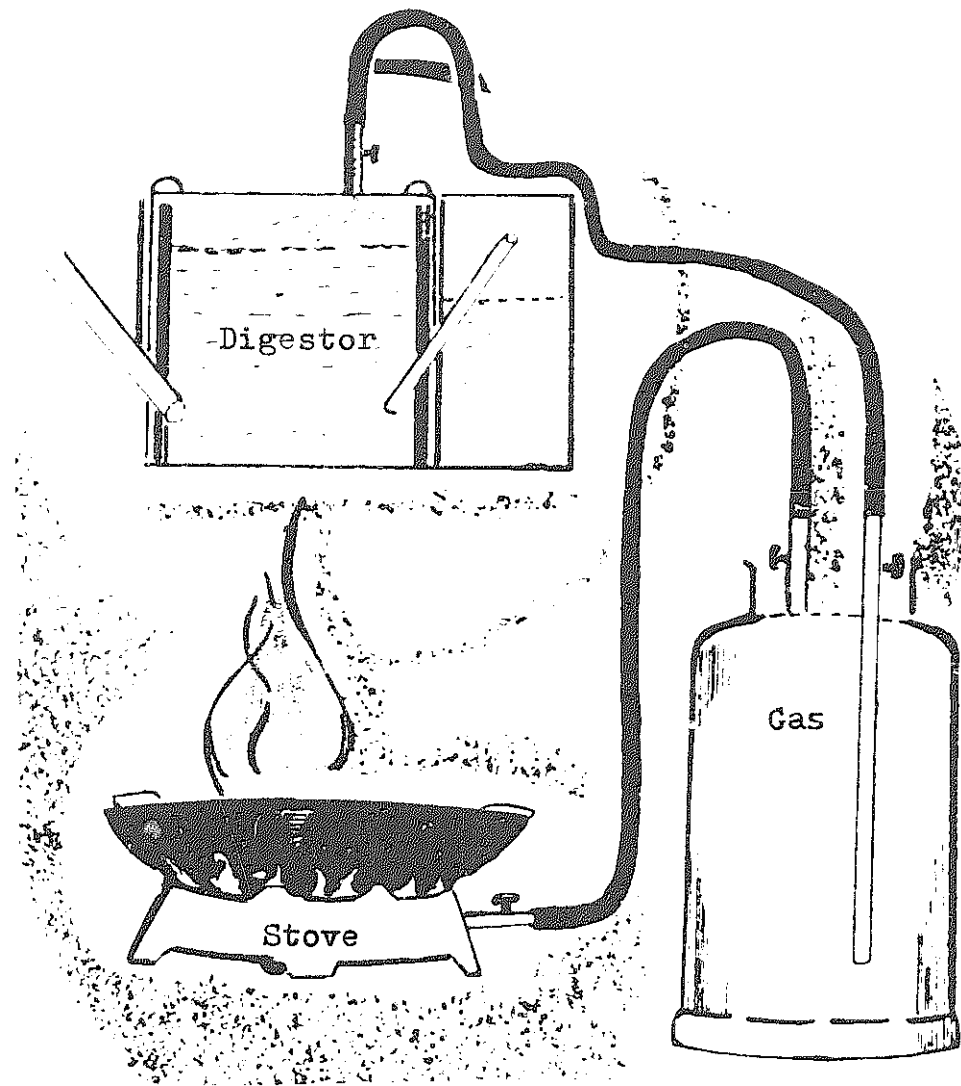

BIO ,OR METHANE GAS

If animal dung from sheep, goats or cows and also poultry, together with such things as sludge from fish ponds as well as other organic matter is fermented in an airtight and water tight tank these will produce methane gas which can be piped to a near-by house and used for cooking and lighting purposes.

An air tight container is necessary, called a digester, in which the waste is processed. The gas is collected in a storage tank.

At present the cost of building the digester and tank is high for a rural family but many attempts are being made to reduce this. Both India and China now have many of these plants in action.

ACKNOWLEDGEMENTS

- Farm Implements for Arid and Tropical Regions. F.A.O.
 Pages, 23, 40, 45
- Rural Home Techniques Vols. 1 - 4 F.A.O.
 Pages 24, 25, 34, 36, 37, 38, 51, 52, 53.
- Home making around the World. I.C.A. /US.AID
 Pages 26, 31
- Appropriate Technology Source Book Volunteers in Asia.
 Pages 27, 30, 42, 58
- Nigeria Magazine No.32
 Pages 28, 29
- German Adult Education Association, Accra.
 Pages 33, 35
- Liklik Book, Papua New Guinea
 Pages 39, 48, 60
- Buyers Guide to Low Cost Agricultural Implements. I.T.D.G.
 Pages, 41, 42, 43, 44, 45, 46, 48, 55, 56, 57, 58.
- Department of Agriculture, Botswana.
 Page 49
- Water Treatment and Sanitation. I.T.D.G.
 Pages 51, 54

MANUFACTURERS OF THE EQUIPMENT ILLUSTRATED
IN POST HARVEST ACTIVITIES AND WATER SECTONS.

Page 41

1. Dandekar Brothers, India
- 2,5 Cossul & Co, PVT. Ltd., India
- 3 American Spring & Pressing Works, PVT. Ltd., India
4. Ce Co Co, Japan.

Page 42

2. Danishmand & Co. Pakistan
- 3 Cossul & Co, PVT, Ltd. India.

Page 43

1. R.H. Hunt Ltd, U.K.
2. Rajasthan State Agro Industries Corporation. Ltd., India
- 3 Ce Cc Co, Japan.

Page 44

1. Ce Co Co, Japan
2. John Gordon & Co, U.K.
3. R.H.Hunt & Co Ltd., U.K.

Page 5

2. Dandekar Brothers, India
3. Rajasthan State Agro Industries Corporation Ltd., India
4. R.H.Hunt & Co.Ltd, U.K.

Page 46

1. Ubongo Farm Implements, Tanzania
2. Dandekar Brothers, India
- 3 R.H.Hunt & Co.Ltd, U.K.
4. Siscoma, Senegal
- 5 Harrap Wilkinson, Ltd, U.K.
6. Hindson PVT., India

Page

1. Ce Co Co, Japan.
- 3 Kirloskar Brothers Ltd, India
- 4 Harrap Wilkinson Ltd., U.K.
- 5: New Britain Engineering, Papua New Guinea.

Page

- 1,2 Kumar Industries Ltd., India
 3 Barnaby Engineering Co. U.K.,
 4,6 Pompes Grillot, France
 5. Lee Howl & Co. U.K.

Page 6

1. Co Co Co, Japan.
 2. Dandekar Brothers, India
 3 Leo Howl & Co.Ltd., U.K.
 4,5 H.J.Godwin Ltd., U.K.
 6. Renson et Cie, France

Page 57

- 1,5, Lee Howl & Co.Ltd., U.K.
 2,6 Renson et Cie, France
 3 Pompes Grillot, France
 4. Newman Battersley International Ltd., U.K.

Page 53

2. Kalayan Engineering Co.Inc, Philippines
 D.H.Farm Implements
 1. Ets Pierre Mengin, France

OBTAINABLE IN BANGLADESH

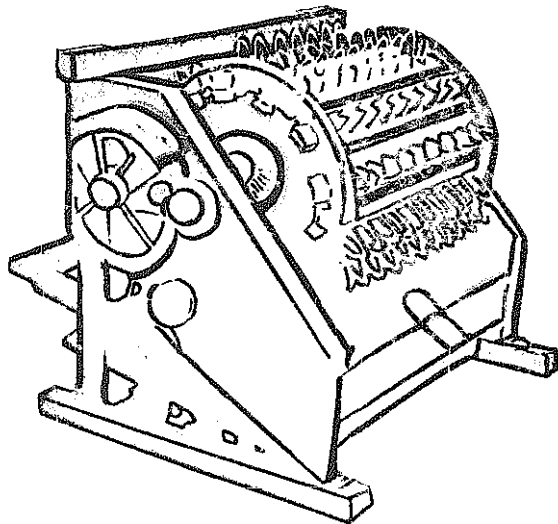
Pedal operated thresher-

Output 48 maunds of paddy
 in 8 hour day
 Measurements, 33"x28"x27" high.
 Weight . 104 lbs.
 Price 875 taka

Comilla Co-operative Karkhana Ltd.
P.O.Box 12, Comilla.

| | |
|-----------------|----------|
| <u>Winnower</u> | 550 taka |
| <u>Weeder</u> | 90 taka |
| <u>Hand hoe</u> | 175 taka |

Agricultural Engineering Workshop, DaccaNot illustrated

- | | | |
|----|-------------------------|----------|
| 1. | Pedal operated thresher | 900 taka |
| 2. | Winnower | 400 taka |

MANUFACTURERS' ADDRESSES

France

Pompes Grillot, 84007, Avignon, Rue de l'Observance. B.P. 118

Ets Pierre Mengin. B.P. 163, 45203 Montargis.

Renson et Cie B.P. 14. 59550 Landrecies.

India

American Spring and Pressing Works ,P.O.Box 7602, Malad, Bombay
Dandekar Brothers, Sangli, Maharashtra.

Cossul and Co. PVT, Ltd. Industrial Area, Fazalgunj. Kanpur
Rajasthan State Agro-Industrial Corporation Ltd., Vivat Bhawan,
C.Scheme, Jaipur 302 006, Rajasthan.

Kumaon Agri-Horticulture Stores. P.O. Kashipur, District Nainital,
United Provinces.

Hindsons PVT.Ltd., The lower Mall, Patiala, Punjab.

Kirloskar Brothers Ltd., Udyog Bhavan, Tilak Road, Poona, 411 002

Kumar Industries Ltd., Edathara 678611, Palghat Dist., Kerala

Japan.

Ce Go Co , P .O.Box 8 ,Iboraki City, Osaka Prefecture 567

Pakistan

Danishmund & Co. Karkhana Bazaar, Lyallpur.

Papua New Guinea

New British Engineering, P.O.Box 163, Rabaul.

Philippines

Kalayan Engineering Co.Inc, P.O.Box 655 HCC, 4255 Emilia Street,
Makati, Rizal.

D.H.Farm Implements. Km.1. National Highway, Roxas City.

Tanzania

Ubongo Farm Implements. P.O.Box 2669, Dar es Salaam.

United Kingdom

R.H.Hunt, Atlas Works, Earls Colne, Essex C.06 2 E.F.

John Gordon, 196A High Street, Epping, Essex CM16 4 AQ

Harrap Wilkinson Ltd., North Phoebe Street, Salford, M5 4 EA

Barnaby Engineering Co., Bourne Road, Bexley, Kent DA5 IL 5.

H.J.Godwin, Quenington, Cirencester, Gloucestershire GL7 5 BX

Senegal

SISCOMA, B.P.3214, Dakar.

BIBLIOGRAPHY

AGRICULTURE

- Workshop on Appropriate Technology
Bangladesh Agricultural Research Council. 1975
- Animal drawn equipment & hand operated machines
U.N.Industrial Development Organisation 1974
- Improvement of the Xiskisan Mill. **Arbolede**
Int.Rice Research Institute, Philippines 1975
- Small scale storage and drying of paddy in Bangladesh.
Merrick Lockwood. Appropriate Technology Cell,Dacca
- Complete technical drawings of items of farm equipment
Intermediate Technology Development Group,London

BIO GAS

- Gobar Gas, why and how ?
Khadi and Village Industries Commission, 3 Irla Rd. Vile Parle
Bombay.
- Methane , planning a digester
prism Press, Conservation, Tools & Technology .U.K. 1976
- Small scale bio gas plants in India
Canadian Hunger Foundation 1976
- Methane Digestors
John L. Pry

BUILDING

- Manual on Building Maintenance Vols 1 & 2
Intermediate Technology Development Group. 1976
- Bamboo as a building material
Office of International Affairs, Dept. of Housing,Washington
U.S. A.
- Manual of Building Construction.
Intermediate Technology Development Group. U.K.
- Handbook for building homes of earth.
Office of International Affairs, Dept. of Housing, washington
U.S.A.
- Shelter. Simple homes in natural materials
Whole Earth Truck Store,558 Santa Cruz Ave. Menlo Park
California 94025. USA

ENERGY

Wind.

- A Survey of possible use of windpower in Thailand & the
Philippines. Heronemus. 1974
Agency for International Development,Washington D.C.20523.USA.
- Food from windmills **F.Frænknkel** 1975
Intermediate Technology Development Group , London.

ENERGY (continued)Water

Low cost development of small water power sites
Volunteers in Technical Assistance, USA. 1971

Windmills and watermills. 1970
Whole Earth Truck Store, 558 Santa Cruz Ave.
Menlo Park, California 94025. USA

Solar

How to build a solar steam cooker.
Brace Research Institute. McGill University, Quebec, Canada.

Energy Primer 1975
Portola Institute

FISH CULTURE

Manual of warm water fish culture. Vancey. 1976
Mennonite Central Committee, Akron, Pennsylvania. USA.

FOOD PRESERVATION

A manual of food preservation M. Islam 1977
UNICEF, Dacca, Bangladesh.

Home Techniques. Vol. 1.
F.A.O. Via delle Termi di Caracalla, 00100, Rome, Italy

How to salt fish
Volunteers in Asia, Box 4543, Stanford, California 94305. USA.

How to make a solar drier for agricultural produce
Brace Research Institute, McGill University, Quebec, Canada.

Technical feasibility & acceptability of sun dried
vegetables in Bangladesh.
Appropriate Technology Cell. Dacca.

Sun dry your fruit and vegetables
U.S. Dept. of Agriculture, Washington, D.C. 20250. USA.

How to dry fruits & vegetables.
Action for Food Production. Technical Information Centre
C.17. Safdarjung Development Area, New Delhi 1100 16, India

Sun drying of fruits and vegetables. Jackson & Mohammed.
FAO, Via delle Termi di Caracalla, 00100, Rome, Italy.

NUTRITION

Developing a soybean Dal for India. Spata
World Crops Vol. 26 (2) 1974

SOAP MAKING

The preparation of soap.
TOOL, Mauritskade 61a, Amsterdam, Netherlands.

Introduction to soap making
 Christian Relief & Development Assn. P.O.Box 5674, Addis Ababa,
 Ethiopia.
 The good idea (soap making)
 German Adult Education Association, P.O.Box 9298, Accra, Ghana.

WATER & IRRIGATION

Water treatment and sanitation Mann & Williamson.
 Intermediate Technology Development Group, London. 1976

Manual on the automatic hydraulic ram. S.B.Watt
 Intermediate Technology Development Group, London 1975

Bibliography of low cost water techniques. Bateman
 Intermediate Technology Development Group, London

Chinese chain and washer pumps S.B.Watt
 Intermediate Technology Development Group, London. 1976

Comparative analysis of small scale irrigation systems
 in Bangladesh. F.Hague
 Bangladesh Development Studies. Vol.III, January 1975

Bamboo piping.
 Christian Relief & Development Assn. P.O.Box 5674, Addis Ababa,
 Ethiopia.

Food from windmills Fraenkel
 Intermediate Technology Development Group., London.

Hand dug wells and their construction. S.B.watt 1977
 Intermediate Technology Development Group, London.

Salawe Pump
 TOOL, Mauritskade 61a, Amsterdam, Netherlands.

Hand Pumps for village wells .
 Volunteers in Technical Assistance, 3706 Rhode Island Ave.
 Mt.Rainier, Maryland 20822, USA.

HANDBOOKS, BUYERS' GUIDES etc

Guide book for rural cottage and small scale industries and
 paddy cultivation.
 Ce Co Co. P.O.Box 8, Ibaraki City, Osaka, Japan.

Wind Energy Bibliography
 Windworks, Box 329 ,Route 3, Mukwonago, Wisconsin 53149, USA

Village Technology Handbook
 Volunteers in Technical Assistance, 3706 Rhoda island Ave.
 Mt.Rainier, Maryland 20822, USA.

Economically Appropriate Technologies for Developing Countries
 An annotated bibliography, Marilyn Carr.
 Intermediate Technology Development Group, London.

Home techniques Four volumes.
 F.A.O. Via delle Termi di Caracalla, 00100, Rome, Italy,

Lik Lik Book
 Melanesian Council of Churches, P. 0. Box 80, Lae, Papua New
 Guinea.

Appropriate Technology Source book
Volunteers in Asia, Box 4543, Stanford, California, USA.

Methane Generation- an annotated bibliography
Intermediate Technology Development Group.

RURAL WORKSHOPS

First steps in Village Mechanisation Macpberson
Tanzania Publishing House, Dar es Salaam, Tanzania.

JOURNALS

Appropriate Technology Quarterly.
Intermediate Technology Development Group, London.

ADAB News. Monthly.
Agricultural Development Agencies in Bangladesh, Dacca

USEFUL ADDRESSES

The Intermediate Technology Development Group, 9 King Street,
Covent Garden, London WC2E 8 HN. England.

Brace Research Institute, MacDonald College of McGill Univer-
sity, Ste Anne de Bellevue, Quebec BOA 1C0, Canada.

Volunteers in Technical Assistance, 3706 Rhode Island Ave.,
Mt. Rainier, Maryland 20822, U.S.A.

Appropriate Agricultural Technology Cell, Bangladesh Agric-
ultural Research Council, 130-B Road 1, Dhanmandi, Dacca.

Transnational network for Appropriate Technologies (TRANET)
P.O. Box 567, Rangeley, Maine 04970 . USA.

Volunteers in Asia, Box 4543, Stanford, California. USA.

TOOL. Foundation. Mauritskade 61a, Amsterdam, Netherlands,

Tropical Products Institute, 52 Grays Inn Road, London WC1.