

SCRIBNER LIBRARY OF DAILY LIFE



**ENCYCLOPEDIA OF  
CLOTHING  
AND FASHION**





## EDITORIAL BOARD

---

***Christopher Breward***

London College of Fashion

***Joanne B. Eicher***

University of Minnesota

***John S. Major***

China Institute

***Phyllis Tortora***

Author of *Understanding Textiles*, *The Fairchild Encyclopedia of Fashion Accessories*, and *The Fairchild's Dictionary of Textiles*



SCRIBNER LIBRARY OF DAILY LIFE



# ENCYCLOPEDIA OF CLOTHING AND FASHION



VOLUME 1:  
Academic Dress to Eyeglasses

*Valerie Steele, Editor in Chief*

**CHARLES SCRIBNER'S SONS**

*An imprint of Thomson Gale, a part of The Thomson Corporation*

**THOMSON**  
—★—™  
**GALE**



## Encyclopedia of Clothing and Fashion

Valerie Steele, Editor in Chief

© 2005 Thomson Gale, a part of the Thomson Corporation.

Thomson and Star Logo are trademarks and Gale and Charles Scribner's Sons are registered trademarks used herein under license.

*For more information, contact*

Thomson Gale  
27500 Drake Rd.  
Farmington Hills, MI 48331-3535

Or you can visit our Internet site at  
<http://www.gale.com>

### **ALL RIGHTS RESERVED**

No part of this work covered by the copyright hereon may be reproduced or used in any form or by any means—graphic, electronic, or mechanical, including photocopy-

ing, recording, taping, Web distribution, or information storage retrieval systems—without the written permission of the publisher.

For permission to use material from this product, submit your request via Web at <http://www.gale-edit.com/permissions>, or you may download our Permissions Request form and submit your request by fax or mail to:

*Permissions Department*

Thomson Gale  
27500 Drake Road  
Farmington Hills, MI 48331-3535

Permissions Hotline:  
248-699-8006 or 800-877-4253 ext. 8006  
Fax: 248-699-8074 or 800-762-4058

While every effort has been made to ensure the reliability of the information presented in this publication, Thomson Gale does not guarantee the accuracy of the data contained herein. Thomson Gale accepts no payment for listing; and inclusion in the publication of any organization, agency, institution, publication, service, or individual does not imply endorsement of the editors or publisher. Errors brought to the attention of the publisher and verified to the satisfaction of the publisher will be corrected in future editions.

### Library of Congress Cataloging-in-Publication Data

Encyclopedia of clothing and fashion / Valerie Steele, editor in chief.

p. cm. — (Scribner library of daily life)

Includes bibliographical references and index.

ISBN 0-684-31394-4 (set: hardcover: alk. paper) — ISBN 0-684-31395-2 (v. 1) — ISBN 0-684-31396-0 (v. 2) — ISBN 0-684-31397-9 (v. 3) — ISBN 0-684-31451-7 (e-book)

1. Clothing and dress—History—Encyclopedias. I. Steele, Valerie II. Series.

GT507.E53 2005

391'.003—dc22

2004010098

This title is also available as an e-book.

ISBN 0-684-31451-7

Contact your Thomson Gale Sales representative for ordering information.

Printed in the United States of America

10 9 8 7 6 5 4 3 2 1



# EDITORIAL AND PRODUCTION STAFF

---

*Project Editor*

Nicole Watkins

*Editorial Support*

Dana Barnes   Sofia Begg   Deirdre Blanchfield   Mark Drouillard   Lynn Koch   Jeffrey Lehman  
Nancy Matuszak   Mark Mikula   Kate Millson   Jenai Mynatt   Jamie Noce   Christine Slovey  
Rachel Widawsky

*Copy Editors*

Richard Rothschild, Printmatters, Inc.   Neil Schlager, Schlager Group, Inc.

*Proofreaders*

Lisa Dixon   Margaret Haerens   Carol Holmes   Allison Leopold   Melodie Monahan   Anna Nesbitt  
Eleanor Stanford   Shanna Weagle

*Caption Writers*

Sofia Begg   Andrew Claps   Shannon Kelly   Lynn Koch   Kimberly A. McCloud   John F. McCoy

*Indexer*

Laurie Androit

*Design*

Pamela A. E. Galbreath

*Imaging*

Dean Dauphinais   Randy Bassett   Leitha Etheridge-Sims   Lezlie Light   Michael Logusz   Robyn Young

*Permissions*

Margaret Abendroth   Ann Taylor

*Compositor*

GGIS Information Services, York, Pennsylvania

*Manufacturing*

Wendy Blurton

*Development Editor*

Sarah Turner

*Senior Development Editor*

Nathalie Duval

*Editorial Director*

John Fitzpatrick

*Publisher*

Frank Menchaca



# TABLE OF CONTENTS

---

## *Volume 1*

*Preface . . . xv*

Australian Dress  
Avedon, Richard

## **A**

Academic Dress  
Acrylic and Modacrylic Fibers  
Activewear  
Actors and Actresses, Impact on Fashion  
Adinkra  
Adire  
Adrian  
Aesthetic Dress  
African American Dress  
Africa, North: History of Dress  
Africa, Sub-Saharan: History of Dress  
Afro Hairstyle  
Afrocentric Fashion  
Agbada  
Alaïa, Azzedine  
Albini, Walter  
A-Line Dress  
Alpaca  
America, Central, and Mexico: History of Dress  
America, North: History of Indigenous Peoples' Dress  
America, South: History of Dress  
Amies, Hardy  
Ancient World: History of Dress  
Angora  
Animal Prints  
Ao Dai  
Appearance  
Appliqué  
Aprons  
Armani, Giorgio  
Armor  
Art and Fashion  
Art Nouveau and Art Deco  
Asia, Central: History of Dress  
Asia, East: History of Dress  
Asia, South: History of Dress  
Asia, Southeastern Islands and the Pacific: History of Dress  
Asia, Southeastern Mainland: History of Dress

## **B**

Balenciaga, Cristóbal  
Ball Dress  
Ballet Costume  
Balmain, Pierre  
Balzac, Honoré de  
Barbers  
Barbie  
Barbier, Georges  
Bark Cloth  
Barthes, Roland  
Batik  
Baudelaire, Charles  
Baudrillard, Jean  
Beads  
Beards and Mustaches  
Beaton, Cecil  
Beene, Geoffrey  
Belgian Fashion  
Belts and Buckles  
Benjamin, Walter  
Beret  
Bertin, Rose  
Best-Dressed Lists  
Biba  
Bicycle Clothing  
Bikini  
Blahnik, Manolo  
Blass, Bill  
Blazer  
Bloomer Costume  
Blouse  
Bodybuilding and Sculpting  
Body Piercing  
Bogolan  
Bohemian Dress  
Boots  
Boubou  
Bourdin, Guy  
Boutique

## TABLE OF CONTENTS

Boxer Shorts  
Bracelets  
Braiding  
Branding  
Brands and Labels  
Brassiere  
Breeches  
Brooches and Pins  
Brooks Brothers  
Brummell, George (Beau)  
Burberry  
Burqa  
Burrows, Stephen  
Bustle  
Buttons

### C

Cache-Sexe  
Caftan  
Calico  
Callot Sisters  
Cambric, Batiste, and Lawn  
Camel Hair  
Camouflage Cloth  
Canes and Walking Sticks  
Capucci, Roberto  
Cardin, Pierre  
Caricature and Fashion  
Carnival Dress  
Cashin, Bonnie  
Cashmere and Pashmina  
Casual Business Dress  
Celebrities  
Ceremonial and Festival Costumes  
Chador  
Chalayan, Hussein  
Chanel, Gabrielle (Coco)  
Chemise Dress  
Children's Clothing  
China: History of Dress  
Chintz  
Clark, Ossie  
Closures, Hook-and-Loop  
Clothing, Costume, and Dress  
Coat  
Cocktail Dress  
Codpiece  
Colonialism and Imperialism  
Color in Dress  
Comme des Garçons  
Communist Dress  
Corduroy  
Corset  
Cosmetics, Non-Western  
Cosmetics, Western  
Costume Designer

Costume Jewelry  
Cotton  
Courrèges, André  
Court Dress  
Cowboy Clothing  
Crepe  
Crinoline  
Crochet  
Cross-Dressing  
Crowns and Tiaras  
Cuff Links and Studs  
Cunnington, C. Willett and Phillis  
Cutting

### D

Dahl-Wolfe, Louise  
Dance and Fashion  
Dance Costume  
Dandyism  
Dashiki  
Debutante Dress  
De la Renta, Oscar  
Delaunay, Sonia  
Demeulemeester, Ann  
Demimonde  
Demorest, Mme.  
Denim  
Department Store  
Diana, Princess of Wales  
Dior, Christian  
Distressing  
Djellaba  
Dolce & Gabbana  
Domestic Production  
Doublet  
Doucet, Jacques  
Dress Codes  
Dress for Success  
Dress Reform  
Dress Shirt  
Dry Cleaning  
Duffle Coat  
Dyeing  
Dyeing, Resist  
Dyes, Chemical and Synthetic  
Dyes, Natural

### E

Earrings  
Ecclesiastical Dress  
Economics and Clothing  
Elastomers  
Ellis, Perry  
Embroidery

Empire Style  
 Equestrian Costume  
 Ethnic Dress  
 Ethnic Style in Fashion  
 Europe and America: History of Dress (400–1900 C.E.)  
 Evening Dress  
 Extreme Fashions  
 Eyeglasses

*Volume 2***F**

Fads  
 Fancy Dress  
 Fans  
 Fascist and Nazi Dress  
 Fashion  
 Fashion, Attacks on  
 Fashion, Historical Studies of  
 Fashion, Theories of  
 Fashion Advertising  
 Fashion and Homosexuality  
 Fashion and Identity  
 Fashion Designer  
 Fashion Dolls  
 Fashion Editors  
 Fashion Education  
 Fashion, Health, and Disease  
 Fashion Icons  
 Fashion Illustrators  
 Fashion Industry  
 Fashion Journalism  
 Fashion Magazines  
 Fashion Marketing and Merchandising  
 Fashion Models  
 Fashion Museums and Collections  
 Fashion Online  
 Fashion Photography  
 Fashion Plates  
 Fashion Shows  
 Fashion Television  
 Fasteners  
 Fath, Jacques  
 Feathers  
 Felt  
 Fendi  
 Ferragamo, Salvatore  
 Fetish Fashion  
 Fibers  
 Film and Fashion  
 First Ladies' Gowns  
 Flannel  
 Flappers  
 Flocking  
 Flügel, J. C.  
 Fogarty, Anne  
 Folk Dress, Eastern Europe

Folk Dress, Western Europe  
 Folklore Look  
 Fontana Sisters  
 Footbinding  
 Ford, Tom  
 Formal Wear, Men's  
 Fortuny, Mariano  
 Fulling  
 Fur  
 Future of Fashion  
 Futurist Fashion, Italian

**G**

G-string and Thong  
 Gabardine  
 Galanos, James  
 Galliano, John  
 Garments, International Trade in  
 Gaultier, Jean-Paul  
 Gender, Dress, and Fashion  
 Gernreich, Rudi  
 Gigli, Romeo  
 Girdle  
 Givenchy, Hubert de  
 Glazing  
 Globalization  
 Gloves  
 Godey's Lady's Book  
 Golf Clothing  
 Goths  
 Grès, Mme.  
 Grunge  
 Gucci

**H**

Hair Accessories  
 Hairdressers  
 Hairstyles  
 Halloween Costume  
 Halston  
 Handbags and Purses  
 Handwoven Textiles  
 Hartnell, Norman  
 Hats, Men's  
 Hats, Women's  
 Haute Couture  
 Hawaiian Shirt  
 Hawes, Elizabeth  
 Head, Edith  
 Headdress  
 Helmet  
 Hemlines  
 Hemp  
 Hermès

## TABLE OF CONTENTS

Heroin Chic  
High Heels  
High-Tech Fashion  
Hijab  
Hilfiger, Tommy  
Hip-Hop Fashion  
Hippie Style  
Historicism and Historical Revival  
Hollywood Style  
Homespun  
Horst, Horst P.  
Hosiery, Men's  
Hoyningen-Huene, George  
Hugo Boss

### I

Ikat  
Implants  
India: Clothing and Adornment  
Indigo  
Inuit and Arctic Dress  
Inuit and Arctic Footwear  
Iran: History of Pre-Islamic Dress  
Iribe, Paul  
Islamic Dress, Contemporary  
Italian Fashion

### J

Jacket  
James, Charles  
Japanese Fashion  
Japanese Traditional Dress and Adornment  
Japonisme  
Jeans  
Jersey  
Jewelry  
Jewish Dress  
Jilbab  
Jockey Shorts  
Jumper Dress

### K

Kaffiyeh  
Kain-kebaya  
Kamali, Norma  
Kanga  
Karan, Donna  
Kente  
Kilt  
Kimono  
Klein, Calvin  
Knitting  
Knitting Machinery

Knotting  
Korean Dress and Adornment

### L

Labeling Laws  
Labor Unions  
Lace  
Lacroix, Christian  
Lagerfeld, Karl  
Lang, Helmut  
Lanvin, Jeanne  
Latin American Fashion  
Latino Style  
Laundry  
Lauren, Ralph  
Laver, James  
Leather and Suede  
Legal and Judicial Costume  
Leiber, Judith  
Leotard  
Lesage, François  
Levi Strauss & Co.  
Liberty & Co.  
Linen  
Lingerie  
Lipstick  
Little Black Dress  
Logos  
London Fashion  
Loom  
Lucile

### M

Macaroni Dress  
Mackie, Bob  
Madonna  
Mainbocher  
Makeup Artists  
Mallarmé, Stéphane  
Mannequins  
Mantua  
Mao Suit  
Margiela, Martin  
Marimekko  
Marks & Spencer  
Marx, Karl  
Masks  
Masquerade and Masked Balls  
Maternity Dress  
McCardell, Claire  
McFadden, Mary  
McQueen, Alexander  
Meisel, Steven  
Microfibers  
Middle East: History of Islamic Dress

Military Style  
 Milliners  
 Miniskirt  
 Missoni  
 Miyake, Issey  
 Modern Primitives  
 Mohair  
 Moore, Doris Langley  
 Mori, Hanae  
 Moschino, Franco  
 Mourning Dress  
 Muffs  
 Mugler, Thierry  
 Muir, Jean  
 Music and Fashion  
 Muslin

**N**

Nail Art  
 Napping  
 Nautical Style  
 Necklaces and Pendants  
 Neckties and Neckwear  
 Needles  
 Nehru Jacket  
 New Look  
 Newton, Helmut  
 Nightgown  
 Nonwoven Textiles  
 Norell, Norman  
 Nudism  
 Nudity  
 Nylon

*Volume 3***O**

Occult Dress  
 Oilskins  
 Olefin Fibers  
 Orientalism  
 Outerwear

**P**

Pagne and Wrapper  
 Paisley  
 Pajamas  
 Panties  
 Paper Dresses  
 Paquin, Jeanne  
 Paris Fashion  
 Parka  
 Patou, Jean  
 Patterns and Patternmaking  
 Penis Sheath

Penn, Irving  
 Performance Finishes  
 Perfume  
 Petticoat  
 Pins  
 Plaid  
 Plastic and Cosmetic Surgery  
 Pockets  
 Pointe Shoes  
 Poiret, Paul  
 Politics and Fashion  
 Polo Shirt  
 Polyester  
 Prada  
 Prison Dress  
 Professional Associations  
 Protective Clothing  
 Proust, Marcel  
 Psychedelic Fashion  
 Pucci, Emilio  
 Punk

**Q**

Qipao  
 Quant, Mary  
 Quilting

**R**

Rabanne, Paco  
 Raincoat  
 Rainwear  
 Ramie  
 Rayon  
 Ready-to-Wear  
 Recycled Textiles  
 Reenactors  
 Religion and Dress  
 Retailing  
 Retro Styles  
 Rhodes, Zandra  
 Ribbon  
 Rings  
 Robe  
 Roma and Gypsy  
 Royal and Aristocratic Dress  
 Rubber as Fashion Fabric  
 Russia: History of Dress  
 Rykiel, Sonia

**S**

Safety Pins  
 Saint Laurent, Yves  
 Salwar-Kameez



TABLE OF CONTENTS

Sandals  
 Sapeurs  
 Sari  
 Sarong  
 Savile Row  
 Scarf  
 Scarification  
 Schiaparelli, Elsa  
 Scottish Dress  
 Seamstresses  
 Secondhand Clothes, Anthropology of  
 Secondhand Clothes, History of  
 Seventh Avenue  
 Sewing Machine  
 Seydou, Chris  
 Shawls  
 Shirt  
 Shirtwaist  
 Shoemaking  
 Shoes  
 Shoes, Children's  
 Shoes, Men's  
 Shoes, Women's  
 Shopping  
 Shroud  
 Silk  
 Simmel, Georg  
 Skating Dress  
 Ski Clothing  
 Skirt  
 Skirt Supports  
 Slip  
 Smith, Paul  
 Smith, Willi  
 Sneakers  
 Social Class and Clothing  
 Space Age Styles  
 Space Suit  
 Spangles  
 Spanish Dress  
 Spinning  
 Spinning Machinery  
 Sport Shirt  
 Sport Shoes  
 Sports Jacket  
 Sportswear  
 Steele, Lawrence  
 Stockings, Women's  
 Street Style  
 Striped Cloth  
 Striptease  
 Subcultures  
 Suit, Business  
 Sumptuary Laws  
 Sunglasses  
 Supermodels  
 Sweater

Sweatshirt  
 Sweatshops  
 Swimwear  
 Sy, Ouman

**T**

Tailored Suit  
 Tailoring  
 Tanning of Leather  
 Tapestry  
 Tartan  
 Tattoos  
 Tea Gown  
 Techno-textiles  
 Teenage Fashions  
 Tennis Costumes  
 Textiles, African  
 Textiles, Andean  
 Textiles, Byzantine  
 Textiles, Central Asian  
 Textiles, Chinese  
 Textiles, Coptic  
 Textiles, Japanese  
 Textiles, Middle Eastern  
 Textiles, Prehistoric  
 Textiles, South Asian  
 Textiles, Southeast Asian Islands  
 Textiles, Southeast Asian Mainland  
 Textiles and International Trade  
 Textile Workers  
 Theatrical Costume  
 Theatrical Makeup  
 Tie-Dyeing  
 Tight-Lacing  
 Toga  
 Toledo, Isabel and Ruben  
 Traditional Dress  
 Travel Clothing  
 Treacy, Philip  
 Trendsetters  
 Trickle-Down  
 Trigère, Pauline  
 Trimmings  
 Trousers  
 T-Shirt  
 Turban  
 Tuxedo  
 Tweed  
 Twentieth-Century Fashion  
 Twiggy

**U**

Umbrellas and Parasols  
 Underwear  
 Uniforms, Diplomatic

Uniforms, Military  
 Uniforms, Occupational  
 Uniforms, School  
 Uniforms, Sports  
 Unisex Clothing  
 Uzanne, Octave

**V**

Valentina  
 Valentino  
 Veblen, Thorstein  
 Veils  
 Velvet  
 Versace, Gianni and Donatella  
 Viktor & Rolf  
 Vintage Fashion  
 Vinyl as Fashion Fabric  
 Vionnet, Madeleine  
 Vogue  
 von Furstenberg, Diane  
 Vreeland, Diana  
 Vuitton, Louis

**W**

Waistcoat  
 Watches  
 Wearable Art  
 Weave, Double  
 Weave, Jacquard  
 Weave, Pile  
 Weave, Plain  
 Weave, Satin  
 Weave, Slack Tension  
 Weave, Twill  
 Weave Types  
 Weaving

Weaving, Machinery  
 Wedding Costume  
 Westwood, Vivienne  
 Wigs  
 Wilde, Oscar  
 Windbreaker  
 Window Displays  
 Windsor, Duke and Duchess of  
 Women's Wear Daily  
 Wool  
 Working-Class Dress  
 Worsted  
 Worth, Charles Frederick

**X**

Xuly Bët

**Y**

Yamamoto, Yohji  
 Yarns  
 Yeohlee  
 Youthquake Fashions  
 Yukata

**Z**

Zipper  
 Zoot Suit  
 Zoran

*Systematic Outline of Contents . . . 469*

*Directory of Contributors . . . 481*

*Index . . . 493*



## PREFACE

---

*The Encyclopedia of Clothing and Fashion* is the product of a new, multidisciplinary field of inquiry and an extraordinary international collaboration. The emerging field of fashion studies, sometimes known as the “new” fashion history, differs significantly from traditional dress history, which tended to focus on the stylistic analysis of elite fashions. By contrast, contemporary fashion studies asks new questions, approaches a much wider range of topics, and draws on the expertise of scholars across the disciplines. Whereas traditional fashion reference books tend to be limited to an alphabetical survey of individual designers, this encyclopedia seeks to provide critical insights into the history and contemporary experience of clothing and fashion. By identifying the world’s preeminent authorities, and by approaching the subject with a global focus and an interdisciplinary perspective, the editorial board of *The Encyclopedia of Clothing and Fashion* aims to provide the interested reader with an authoritative introduction to the wide range of issues that define the field. These issues include Eurocentrism vs. multiculturalism; gender and sexual identity; the relationship between fashion and other cultural manifestations, such as music; theories of fashion; clothing and material culture; and the fashion system, encompassing the design, manufacture, marketing, and representation of fashion. The editors of the encyclopedia, whose expertise spans a wide range of disciplines, subject matter, and geographical areas, have enlisted over 325 authors in an international survey of clothing, fashion, and related subjects from prehistoric times to the present.

*The Encyclopedia of Clothing and Fashion* contains 640 essays ranging from specific topics such as “African Textiles” and “Zoot Suit” to conceptual articles such as “Globalization” and “Music and Fashion,” the latter cross-referenced to related entries such as “Hip-Hop Fashion.” Naturally, we have tried to include all of the topics that readers would expect to find, including essays on specific fashion designers: Christian Dior, Coco Chanel, Yves St. Laurent, and dozens more. But these essays are neither hagiographies of great “artists” nor potted biographies of successful businesspeople. Of the hundreds of possible candidates for inclusion, we have concentrated on those who made a lasting contribution to the arts of fashion and to fashion culture; each designer’s work is not only described in detail but also analyzed with reference to its social and cultural context. Readers interested in, say, Dior can also find related essays on topics such as the “New Look” and “Paris Fashion.” Of course, fashion is a part of most people’s lives, not only because they wear clothes, but also because they constantly consume images of fashion. This encyclopedia addresses the subject of fashion across the media, with essays on “Fashion Photography” (and on individual photographers such as Richard Avedon, Guy Bourdin, and Helmut Newton), “Caricature and Fashion,” and “Film and Fashion.” The encyclopedia also includes unexpected topics, such as “Cross-dressing,” “Footbinding,” and “Supermodels.” There is even an essay on “The Future of Fashion.” Because the production and marketing of textiles, clothing, and accessories is an integral part of the fashion system, the encyclopedia includes a wide range of essays on such topics as “Techno-textiles,” “Sweatshops,” “Fashion Magazines,” and “Department Stores.”

Typically, fashion refers to the phenomenon of a regular pattern of change in the prevailing mode of dress. Thus, for example, it could be said that miniskirts were in fashion during the 1960s. Most writers assumed that there existed a vast difference between modern Western fashion and traditional non-Western “costume.” (For detailed analyses

of “fashion” and other closely related terms, and a discussion of the important distinctions among them, please refer to the individual essays on “Fashion” and on “Clothing, Costume, and Dress.”) Traditionally, most publications on fashion have focused almost exclusively on couture or designer fashions worn by elite Western women during the past 200 years. The clothing, adornment, and bodily practices of men, subcultural groups, working-class people, and non-Western and/or premodern peoples tended to be regarded as existing outside the realm of fashion; such topics were treated by scholars, if at all, as subfields of sociology, anthropology, folk arts, or decorative arts. This encyclopedia takes a very different approach. There are, for example, numerous entries on the clothing fashions of different historical periods and geographical areas. Fashion, in these pages, is not treated solely as a phenomenon of the modern Western world; full recognition is given to such fashion-oriented cultures as Tang dynasty China and Heian period Japan. (See, for example, the entries on “China, History of Dress,” “Japanese Traditional Dress and Adornment,” and “Japanese Fashion.”) Survey essays in those fields are complemented by more specific topical entries (“Kimono”; “Qipao”), just as Phyllis Tortora’s magisterial survey of “Europe and America, History of Dress (400–1900 C.E.)” sets the stage for numerous topical entries for the world of Western dress. And as Parminder Bhachu’s essay on “Salwar-Kameez” demonstrates, the categories of “Western” and “non-Western,” like those of “traditional” and “modern” dress, are highly permeable; similarly, disciplinary boundaries between history, sociology, anthropology, material culture, and other academic fields are transcended in the new field of fashion studies. It has been our explicit aim in this encyclopedia to create a work that is historical, cross-cultural, and multicultural in approach, and that will facilitate dichronic and comparative research.

The editorial team spent considerable time and effort identifying significant topics and commissioning articles from scholars who are among the world’s leading authorities in their fields. Dorothy Ko, for example, is unquestionably the world’s greatest expert on footbinding. A respected scholar of Chinese women’s history, Professor Ko takes an unexpected, yet thoroughly documented, view of this 1,000-year practice. Readers of her essay may want to explore further by reading her book *Every Step a Lotus* (2001). Elizabeth Barber, author of our essay on “Prehistoric Clothing,” is famous as the author of *Women’s Work: The First 20,000 Years* (1994). Elizabeth Anne Coleman, whose 1982 exhibition *The Genius of Charles James* at the Brooklyn Museum was one of the first museum exhibitions to treat fashionable dresses unambiguously as works of art, has contributed a deeply insightful survey of James’s work for this encyclopedia; her catalogue of that exhibition is *the* authoritative book on the subject. The list of highlights could go on and on. Walter Karcheski Jr., chief curator of the Frasier Historical Arms Foundation and a world-renowned historian of armor, has contributed an exemplary essay on armor with particular attention to its relationship with clothing. The essay on “Jewish Costume” by Orpa Slapak and Esther Juhasz of the Technical University of Israel is both wide-ranging and deeply learned. One of the greatest pleasures of being Editor-in-Chief of this book has been the opportunity to read hundreds of lucid and authoritative essays by a stellar team of expert contributors.

Since the nineteenth century there have been numerous descriptive and illustrated histories of dress, including classic works such as Auguste Racinet’s six-volume *Le Costume Historique* (1888), Octave Uzanne’s *Les Modes de Paris* (1898), and Elizabeth McClellan’s *Historic Dress of America* (1906). There were also pioneering attempts to interpret the cultural significance of fashion, such as Thorstein Veblen’s *Theory of the Leisure Class* (1899), George Simmel’s *Philosophie der Mode* (1905), and J.C. Flügel’s *The Psychology of Clothes* (1930). (The history of the study of fashion is also described and analyzed in this encyclopedia; see the essays on “Historical Studies of Fashion” and “Theories of Fashion,” as well as individual essays on many of the most important fashion theorists from “Jean Baudrillard” and “Walter Benjamin” to “George Simmel” and “Thorstein Veblen.”)

Among the most popular fashion histories published in the mid-twentieth century were those by James Laver, C. Willett Cunnington, and François Boucher, who amassed a wealth of information and developed a detailed chronology of styles, although Laver’s and Cunnington’s attempts to interpret these styles, often in terms of women’s sexual

psychology, were seriously flawed. More useful in the long run were detailed studies based on the interpretation of artifacts, often carried out by curators or collectors such as Doris Langley Moore. Their work laid an essential foundation for further advances in the study of clothing and fashion. There remains a division between object-oriented researchers (often curators) and university-based fashion theorists (some of whom lack detailed knowledge about the history and construction of dress). As with maritime and military history, dress history has become increasingly concerned with larger issues of social and cultural significance; as the field has moved on, some scholars have remained trapped in older, antiquarian approaches to the subject. Conversely, until very recently few scholars outside the narrow confines of costume history showed any interest in clothing as a subject of scholarly enquiry, probably in part because of the long association of fashion with “femininity” and “frivolity.” Certainly, few academics thought of fashion as a subject to be taken seriously. (For example, scholarly studies of history very seldom include index entries for “clothing,” “dress,” “fashion,” and related items.) The basic fact that virtually all humans wear clothes on a daily basis was perhaps too obvious to be noticed; it faded into the background of ordinary behavior.

In recent years, however, the study of fashion has been revolutionized, as scholars from other disciplines began exploring the intersections between dress, body, and the cultural construction of identity. Awareness began to spread in the academic world that clothing is not only a part of daily life, but that the ways people choose, acquire, wear, and vary their dress can say a great deal about such issues as class, gender, sexual preference, ethnicity, group identity and behavior, and aesthetics. Cultural, social, and economic historians, art historians open to new methodologies, anthropologists, semioticians, philosophers, students of material culture and design history, and scholars informed by feminist theory, critical theory, cultural studies, and studies in gender and sexuality all showed increasing interest in the hitherto despised subject of fashion. Pioneering works include Ellen Moers’ *The Dandy* (1960), Anne Hollander’s *Seeing Through Clothes* (1978), Dick Hebdidge’s *Subculture: The Meaning of Style* (1979), Philippe Perrot’s *Les Dessus et les dessous de la bourgeoisie* (1981), Elizabeth Wilson’s *Adorned in Dreams* (1985), my own first two books *Fashion and Eroticism* (1985) and *Paris Fashion* (1988), Rozsika Parker’s *The Subversive Stitch* (1989), Daniel Roche’s *La Culture des apparences* (1989), and Caroline Evans’s and Minna Thornton’s *Women and Fashion* (1989). By the 1990s, the field was rapidly expanding.

In 1997, when I founded *Fashion Theory: The Journal of Dress, Body & Culture*, the journal took as its starting point a definition of “fashion” as “the cultural construction of the embodied identity.” By that definition, the term fashion embraced all forms of self-fashioning—from street styles like punk and hip-hop to body alterations such as tattooing and piercing. In many ways, this encyclopedia represents the flowering of a new generation of fashion scholars and curators, many of whom have published in *Fashion Theory*. Among them are Rebecca Arnold, Djurdja Bartlett, Christopher Breward, Caroline Evans, Amy de la Haye, Peter McNeil, Alexandra Palmer, and Claire Wilcox, to name only a few. Yet those wishing to study fashion still confront problems with professional training, since few universities offer advanced degrees in the subject. Nevertheless, the new approach to fashion studies has had a real and positive impact, not only in academe but in the museum world as well.

Just as the history of fashion was becoming richer and more theoretically sophisticated in the 1980s and 1990s, so also the exhibition of fashion in museums was moving away from static antiquarian displays to theatrical presentations of innovative themes. As fashion exhibitions proliferated, a much wider public began to take fashion seriously as a cultural phenomenon. The recent revolution in the study and display of fashion has contributed to the richness and depth of this encyclopedia and will also, I believe, make it a work that is interesting and useful to a very large and diverse readership. It will appeal, of course, to professionals and students in fashion design, museum studies, theatrical costume, textile arts, and other strongly clothing-related fields; but I hope it will also be extensively used by “mainstream” historians, anthropologists, literary scholars, journalists, and many others. Because all people wear clothes, there is almost no field of enquiry into

## PREFACE

human affairs that cannot be enriched by a consideration of clothing and fashion; I hope that this encyclopedia, the first of its kind, will assist its readers in making use of that insight.

I would like to thank the members of my editorial board—Associate Editors Christopher Breward, Joanne Eicher, and John Major, and Consulting Editor for Textiles Phyllis Tortora, for their inestimable contributions to this project. They suggested topics for entries, used their extensive professional networks to help me recruit potential authors, chased tardy authors when necessary, read and gave expert critical opinions on draft essays, and themselves each wrote several essays in their own areas of expertise. Throughout the process of creating this encyclopedia they were diligent, cheerful, supportive, and always ready to help. This book would hardly have been possible without their participation. My thanks also go to the professional staff of Charles Scribner's Sons, particularly Senior Development Editor Nathalie Duval, Development Editor Sarah Turner, and Project Editor Nicole Watkins. Their professionalism, hard work, and good humor were invaluable and very much appreciated by me, my Editorial Board colleagues, and the hundreds of contributors who participated in this great collaborative project. Finally, I would like to thank each of the hundreds of professionals who contributed essays to this encyclopedia and thus made it possible to present to the public this reference work of innovative scope and enduring worth.

*Valerie Steele*  
*New York, October 2004*





**ACADEMIC DRESS** Academic dress is the formal attire worn by students and officials at a commencement or graduation ceremony. The most common styles emulate the everyday clothing worn by scholars at the first universities in the eleventh and twelfth centuries. Typically, this included a flowing gown, a hood or cape, and some sort of head wear; the contemporary form of this ensemble depends on the rules dictated by the institution with which the student or official is associated.

### Origin and History

The ancient universities were established in Italy and France in the late eleventh and early twelfth centuries, with the University of Oxford following in circa 1115 and Cambridge in circa 1209. It was these two English schools that set the tradition for academic dress by establishing strict decrees for their students and officials; the subsequent influence of the British Empire spread this tradition to many parts of the world.

Historically, schools of higher learning were referred to as *stadium generale* or *universitas*; titles conferred by the Pope of the day, with the latter being the higher honor. This early association with religion can still be seen in the similarities between academic dress and church robes. However, the early schools were not religious orders as a rule, but rather scholastic guilds made up of students and teachers organized around a cathedral or monastery. Not necessarily priests, the scholars wore clothes that were a sober reflection of lay fashions. In this respect, it was the degree that signified the scholar's full membership in the learned corporation, not the robe.

In medieval times the term "bachelor" was used to describe the assistant of a small landowner; the apprentice as opposed to the master who was already skilled, hence the academic use of the term "master" as well. Both of these titles were in widespread use in the universities during the thirteenth century. As such, there was a structure within these institutions related specifically to the degree of knowledge obtained by the scholar. This hierarchy, along with the medieval style of clothing, became the basis of academic dress.

### The Cap and Gown

Medieval dress consisted of a flowing gown or *cappa clausa*, with a cape or cloak draped over the top. This of-

ten had a cowl-like appendage that could be pulled over the head, much like a hooded cape or *capitium*. By the second half of the fifteenth century, the fashion had progressed toward an open gown, said to be an expression of the new acceptance of academic learning and the arts. From 1490 onward this gown became standard academic dress, with the hooded cape becoming more ornamental than practical. Most commonly, bachelors and masters scholars wore black gowns made of "princes stuff" or "crape," with the senior man's garment having wider sleeves to allow for movement while teaching. The dress hood took the form of a drooping cape, lined with silk or fur to denote the scholar's faculty or social status. For example, in 1432 Oxford forbade the use of miniver for anyone except Masters of the Arts and those of great wealth or noble birth. Variations in sleeve style and lining continued to mirror fashionable dress, and by the sixteenth century academics followed professionals and the clergy in the wearing of caps.

It is difficult to pinpoint the origins of the academic cap, but it is thought to have evolved as a variation on the ecclesiastic *pileus* cap and the medieval head scarf. Most contemporary graduates wear the trencher form of the *pileus quadratus*—or the Oxford mortarboard. This consists of a small skullcap, shaped to fit the head, and a flat, square top, adorned with a silk tassel. This form of headwear became popular with the clergy after the Restoration, when it was thought that emphasizing "squareness" denoted greater dedication. However, the modern academic form was not popularized until the eighteenth century, when wood or card was used to stiffen the square. Some philosophical doctors or secular doctors may wear a variation of the Tudor Bonnet, a softer, fuller hat, or if of Scottish origin, the John Knox cap.

### Contemporary Academic Dress

Most contemporary graduates wear a variation of the Oxford or Cambridge bachelor of arts gown. The Cambridge gown is knee-length, "princes stuff" and has pointed, open sleeves: the seam on the forearm is unsewn to the cuff, allowing a generous hole for the arm to pass through. The hood is partly lined with white fur or silk that is colored to denote the degree of the wearer. The sleeveless Oxford "commoners" gown sits a little below



**French director Claude Autant-Lara in academic dress.** Flowing gowns and robes have been a major part of formal academic attire since medieval times. © ROBERT PATRICK/CORBIS SYGMA. REPRODUCED BY PERMISSION.

the knee and is expected to be worn with lay clothes that conform to a strict code. The lining of the hood is again appropriate to status. Hugh Smith's *Academic Dress and Insignia of the World* (1970) provides a thorough reference for those interested in all dress variations.

In the United States most universities accept the Inter-Collegiate Code (1895) of academic dress, a variation on the Cambridge style, but with an extensive system of color coding that denotes both the degree and the university. In many other countries students do not wear any academic dress: in Germany, it is seen as a sign of respect for the teachings of Martin Luther; in the former Soviet Union, students receive medallions; in Finland, doctors don swords for their commencement. And in many more countries, adaptations have been made to the English model, with Native Americans adding traditional jewelry and head wear, New Zealand Maoris wearing feathered capes, and Australian Aborigines adopting red, yellow, and black capes. Certainly, the fact that academic dress pays homage to establishment and tradition makes it the perfect dress for subversion.

### Dress in American High Schools

The use of the cap and gown in American high schools originated in 1911 as a means of providing an economical and egalitarian code of dress. American educators joined

with the academic dress companies to design an official ensemble for the high school graduate. It was gray, with long, pointed sleeves and the Oxford mortarboard cap. One of those who pushed for such dress in schools was the principal of Englewood High, Chicago, James Armstrong. He believed that the adoption of academic dress would ease the burden on parents to provide fashionable and expensive graduation outfits. By the early 2000s, traditional gray had been replaced by the official colors of the particular school, with religious or private girls' schools opting for white, grammar schools for maroon. Across America the cap and gown has been adopted by many institutions, with even nursery schools conferring honors on their infant graduates. This practice has not been widely emulated beyond the United States; however, some schools in Australia and Asia have adopted the practice.

As a means of historical record, academic dress encapsulates medieval fashion, preserving its character and form for what is an important modern occasion, both to the graduates and to those who have carried them through their time as a scholar. Hence, this form of dress is both steeped in tradition and very distinct from everyday clothes—such contrast clearly conveys significant achievement.

See also **Uniforms, School.**

### BIBLIOGRAPHY

- Goff, Philip. *University of London Academic Dress*. London: University of London, 1999.
- Smith, Hugh. *Academic Dress and Insignia of the World*. 3 vols. Cape Town, South Africa: Balkema, 1970.
- Walters, Helen. *The Story of Caps and Gowns*. Chicago and New York: E. R. Moore Publishing Company, 1939.

### Internet Resources

- Cox, Noel. "Academic Dress in New Zealand." Auckland: Private Monograph. Available from <<http://www.geocities.com/noelcox/Introduction.htm>>.

*Joanne McCallum*

**ACETATE.** See **Rayon.**

**ACRYLIC AND MODACRYLIC FIBERS** Acrylic and modacrylic fibers are produced from acrylonitrile, a petrochemical. The U.S. Federal Trade Commission defines fibers of 85 percent or more acrylonitrile units as acrylic fibers: for modacrylics the figure is 35–85 percent. Early fibers were based on 100 percent acrylonitrile, but more successful versions were produced by the inclusion of up to 15 percent of other chemical units that improved the ability of the resulting fiber to absorb dyes. In the 1950s, a golden age of new synthetic fibers, acrylic fibers became well known under trade names such as Orlon, Acrilan, Zefran, Creslan, and Courtelle; modacrylics included Dynel, Teklan, and Verel.



The variability of chemical composition, together with differences in fiber production methods, mean individual versions of acrylic fibers differ from each other more than other synthetic fibers. Likewise, many different modacrylic fibers have been produced, although they tend to contain considerable amounts of chlorine-based units. This chlorine component provides the flame-resistant properties of modacrylics. The market share of both acrylic and modacrylic fibers has declined somewhat since the 1980s, and although generically separate, it is appropriate to discuss them together.

Acrylic fibers have round or moderately irregular cross sections typically characterized as bean, dog-bone, or peanut shaped. A given volume of fiber is comparatively lightweight (fiber density is 1.17). Acrylic fibers are approximately half as strong as nylon or polyester (tenacity is 2–3.5 g/d), and they have limited use where strength is a major requirement. Like most synthetics, they absorb little water (moisture regain is 1–2 percent), and acrylic fiber materials are quick drying. Fibers recover well from small amounts of stretching. They have excellent resistance to sunlight and weathering and to a wide range of chemicals, particularly inorganic acids. They are thermoplastic, softening at 450–500°F (230–260°C), and can be heat set and texturized, although excessive heat will cause yellowing. Modacrylics have similar properties except a higher density (~1.35), softening temperatures that are 50–100°F lower, and the “self-extinguishing” flame response that comes from the chlorine content.

The variable chemical units in the fiber allowed for fibers of differing dyeing behavior, and some were produced to be dyeable with acid dyes, as wool is. In the early 2000s, most acrylic fiber variants are dyed with basic (cationic) dyes. Many early synthetic dyes (including Perkin’s Mauve were basic dyes, and these were adopted for acrylics, but dyemakers later developed “modified” basic dyes specifically for use with these fibers. Disperse dyes may also be useful for pale shades. A considerable amount of acrylic and modacrylic fiber is colored during manufacture, either as “solution dyed” fiber or by applying dye to the fiber immediately after spinning in “gel-dyeing.”

Most acrylic is produced as staple fiber, and bulky yarns are generated from blending fibers of different shrinkage properties. Fibers made from two different acrylic materials (“bicomponent fibers”) produce especially bulky fibers and yarns. As the ease of creating bulky yarns suggests, and the suffix “-lan” or “-lon” implies, the fibers find favor in wool-like end uses: sweaters, blankets, socks, knitting yarn. In microfiber versions, acrylics make very soft scarves. Flammability issues and a lack of resilience has limited application of acrylic fibers in carpets. For many years, sweatshirts and pants were based on blends of cotton and acrylic fibers: polyester has now taken over the synthetic role in that end use. Modacrylic and acrylic fibers make the most successful fake furs and are widely used in hairpieces and doll hair. The superior sunlight resistance of both fibers makes them useful for

outdoor applications such as awnings, with modacrylics providing additional flame resistance. The low flammability of modacrylics provides a measure of safety despite the low softening temperature: end uses based on this property have included airline blankets and military sweaters. Acrylic fibers are used as starting materials in the production of carbon (graphite) fibers.

Articles made of acrylic fibers are easy to care for: they dry easily and, if properly set during manufacture, maintain their dimensions. Excessive conditions may cause loss of bulk or shrinkage. Acrylic and modacrylic fibers are now mature: cheaper polyester has taken over several of their end uses.

*See also* **Dyeing; Fibers.**

#### BIBLIOGRAPHY

- Adnaur, Sabit. *Wellington Sears Handbook of Industrial Textiles*. Lancaster, Pa.: Technomic, 1995.
- Burkinshaw, S. M. *Chemical Principles of Synthetic Fibre Dyeing*. Glasgow, New York: Blackie Academic and Professional, 1995.
- Cook, Gordon J. *Handbook of Textile Fibres, Part 2: Man-Made Fibres*. 5th ed. Durham, U.K.: Merrow, 1984.
- Moncrieff, R. W. *Man-Made Fibres*. 6th ed. London: Newnes-Butterworth, 1975.

*Martin Bide*

**ACTIVEWEAR** The clothing known as activewear in the early 2000s traces its origins back to the high-performance sportswear designed for mountaineering, sailing, and hiking that became popular among urban youth during the 1970s. By the 1980s, such utilitarian styles swept through college campuses in North America, and, subsequently, sneakers were worn with suits, backpacks replaced briefcases, anoraks were paired with deck shoes, and sweatshirts were combined with khaki trousers or jeans. As the style began to characterize the sporty chic of city dwellers and coed campus life, activewear became a staple of the modern wardrobe.

While activewear is often regarded as a contemporary style, the combination of street clothes, travel accessories, and sportswear is nothing new. In the 1930s and 1940s, the American designers Bonnie Cashin, Claire McCardell, and Vera Maxwell updated garments produced for travel, leisure, and sport with vestiges of high fashion. The designers made functionality a statement of style by producing easy-fit, loosely constructed clothing in fabrics such as wool, denim, and calico. One of Cashin’s signature garments was an overcoat with an integral purse, while Maxwell designed a jacket with built-in bags rather than pockets. Such garments were conceived as urban tools that expanded into wearable luggage, widening the appeal of apparel that could maximize the performance of clothing as well as the body’s ability to transport necessities with ease.

For several decades, activewear was characterized by bulky, loose-fitting garments. As the body-conscious styles of the 1990s took hold, activewear gradually became more tailored and form-fitting, yet continued to suit the active leisure interests of urban dwellers. Dress codes became more fluid as Rollerbladers, inner-city cyclists, and speed-walking pedestrians dressed in smart basics that moved easily and provided protection from adverse weather. Mobility and versatility became key considerations for professionals, who started commuting to work in sneakers and multifunctional outer garments. Many were made with detachable hoods that transformed overcoats into raincoats as they were buttoned or zipped into place, or designed with removable collars and detachable sleeves that could be adapted to weather changes.

The hoods, zip-front seams, windproof jackets, pouch pockets, Velcro, and magnetic fastenings of activewear have become part of the everyday fashion vocabulary, along with drawstrings fitted at the neck, sleeve, and waist to make zippers and buttons redundant. Maharishi popularized these tailoring details on the catwalk as the 1990s drew to a close, updating them with elements of occupational uniforms to create a signature militaristic style. The rise of activewear's popularity throughout the 1990s indicated that the traditional compartmentalized wardrobe no longer sustained shifting social and cultural needs. As the style formed an essential part of the modern wardrobe, it encouraged the movement of materials and technologies across disciplines, moving high-tech fabrics into the collections of forward-thinking fashion designers. Activewear's multifunctional, dynamic features seemed to herald the dawn of twenty-first century fashion in garments that fused fashion with high-performance sportswear.

Labels such as CP Company, Mandarin Duck, Issey Miyake, Vexed Generation, and Final Home were among the first to use advanced textile technology to create an edgy, urban aesthetic in designs as durable as they were chic. CP Company led the pack with designs that transcended fashion altogether; their overcoats transformed into one-person tents or inflated into air mattresses, and their parkas puffed up into armchairs. The garments are transformed by the wearers themselves, introducing a notion of technical skill required beyond the point of purchase. Likewise, the "Jackpack," designed by Mandarin Duck in Italy, integrated a backpack's straps, fastenings, and compartments within the fabric of the jacket's back panel. By taking the jacket off, turning it inside out, and folding the sleeves, lapels, and fabric panels into an internal pouch, the structure of the garment was completely transformed. The pouch contains other zippered compartments for stowing away shopping or other items of clothing. Issey Miyake, for his "Transformer" series, also designed cotton jackets that concealed a nylon raincoat within.

The British fashion duo Vexed Generation countered the problems of modern life with clothing crafted from

bullet-proof and slash-proof materials. Their designs combined high-performance fabrics with cutting-edge street style in garments incorporating many of the functions associated with protective clothing. Temperature-regulating materials manufactured for sportswear were incorporated into their winter coats, ending the need for bulky layering. By lining jackets and overcoats with phase-change materials such as Outlast, Vexed Generation created outer garments that could function as personal thermostats. Tiny paraffin capsules in the phase-change fabrics expand when body temperature climbs, absorbing the heat. Once body temperature drops below 98.6° F (37° C), they contract, releasing the heat they have stored. By maintaining a mean temperature within changing climatic environments, Vexed Generation created a comfort zone for the wearer.

The Japanese designer Kosuke Tsumura's signature garment, the Final Home jacket, expands the mobility of activewear into an expression of architecture as he claims that clothing constitutes the ultimate shelter. The multifunctional, transparent jacket is a nylon sheath equipped with forty-four zippered pockets that can be lined with warm materials for extra insulation, or cushion the wearer when sitting or reclining. Tsumura sees the jacket as a protective shell that enables the wearer to withstand harsh weather conditions. Along with personal items and accessories, Tsumura suggests that some of the pockets be filled with survival rations and practical supplies, eliminating the need for backpacks, shopping bags, luggage, and even tool kits.

As fashion consumers continue looking to activewear to reconcile the demands of the modern lifestyle, the boundaries between street clothes, office attire, and sportswear are blurring even further. High-performance designs and technologically advanced textiles are common to all three, as comfort, flexibility, and protection become central to all parts of the modern wardrobe. As the garments are updated with innovations that transcend conventional clothing, activewear is proving to be one of the fastest moving areas of fashion in the early 2000s. New tailoring techniques radically streamline the designs each season, and future styles of activewear portend such sophistication that the gym is probably the last place one can expect to see them.

See also **Outerwear; Sportswear.**

#### BIBLIOGRAPHY

- Barnard, Malcolm. *Fashion as Communication*. London: Routledge, 1996.
- Bolton, Andrew. *The Supermodern Wardrobe*. London: V & A Publications, 2001.
- Jones, Terry, and Avril Mair. *Fashion Now*. Cologne, Germany: Taschen, 2003.
- McDowell, Colin. *The Fashion Book*. London: Phaidon Press, Ltd., 2000.
- Quinn, Bradley. *Techno Fashion*. Oxford: Berg, 2002.

Bradley Quinn

**ACTORS AND ACTRESSES, IMPACT ON FASHION** Professional actors and actresses have long fascinated their audiences, but until the twentieth century, they were often associated with licentious sexual behavior, making them problematic role models. Perhaps the

first true stage professionals, in the modern sense, were the men and women who made up the repertory companies of the Italian commedia dell'arte in the sixteenth and seventeenth centuries. The stock characters they impersonated, such as Harlequin, Columbine, and Pierrot, left



**A tailor makes adjustments to a gown for actress Betty Grable.** Hollywood stars of the 1930s and 1940s had a great impact on style, setting many fashion trends both onscreen and off. © JERRY COOKE/CORBIS. REPRODUCED BY PERMISSION.



their mark on fashion. Shirts for women in the twentieth century have sported an extravagantly ruffled collar like that of Pierrot, while the diamond-patterned fabric of Harlequin's costume is now part of the fashion lexicon.

In England, theaters were established in London during the Elizabethan Age, but the first thing the Puritans did upon taking control of the city of London in 1620 was to close them. After the Royalist defeat in the English Civil War, Charles II, the future king of England, had to flee to Paris. He remained in exile there for a decade at the court of Louis XIV, where he saw actresses, whose costumes reflected current trends in fashion, on stage both at court and in the fashionable playhouses. When he returned to London in 1660, theater flourished; his most famous mistress was the actress Nell Gwyn. It was during his reign that the "first night" of a new play became both a social event and a dress parade, as it has remained ever since.

In the eighteenth century, the English actress Mrs. Sheridan (1754–1792), wife of the playwright Richard Brinsley Sheridan, was painted by Sir Joshua Reynolds and Thomas Gainsborough. Other actresses sat for fashionable portraitists, and their dress and hairstyles were widely copied. Caroline Abington, who married into the aristocracy, was perhaps the first fashion consultant; she was driven around London to advise her wealthy, titled friends on sartorial matters, particularly if a ball or marriage was imminent.

Many French actresses also had an influence on fashion. Sarah Bernhardt (1844–1923), in particular, was famed for her stylish clothes. She toured the world and was the first actress to be dressed for the screens of the new cinema by a couturier. In 1913, when her play *Elizabeth I* was filmed, she asked Paul Poiret to create her wardrobe, setting a trend that other couturiers would follow, from Coco Chanel and Hubert de Givenchy to the more recent long-term collaboration on- and off-screen between Yves St. Laurent and Catherine Deneuve.

The actor, writer, and director Noel Coward (1899–1973) made a polka-dotted silk Sulka dressing-gown part of every well-dressed man's wardrobe. His favored actress, Gertrude Lawrence, wore a backless dress on stage in *Private Lives* in 1930 and the style instantly became fashionable. Jean Harlow set trends in hair and makeup—the "silver screen" succeeded where the stage had always failed: it made the wearing of makeup not only respectable but a fashionable necessity.

In the early twenty-first century, the stage has less impact than film in fashion terms. The fashionable theatrical couples of the 1930s and 1940s—the Oliviers and the Lunts, for example—were eclipsed by the cinematic duos of the second half of the twentieth century and beginning of the twenty-first century. However, the stage door still has its appeal: its glittering first nights, its gala evenings, and its award ceremonies—all of which, like the Academy Awards, demand "occasion dressing," and act

as yet another showcase for designers and stylists canny enough to offer up their services.

See also **Animal Prints; Film and Fashion; Theatrical Costume; Theatrical Makeup.**

#### BIBLIOGRAPHY

- Bruzzi, Stella. *Undressing Cinema: Clothing and Identity in the Movies*. London: Routledge, 1997.
- Hartnoll, Phyllis. *The Theatre: A Concise History*. Rev. ed. London: Thames and Hudson, Inc., 1985.
- Laver, James. *Costume in the Theatre*. New York: Hill and Wang, 1965.
- Pointon, Marcia. *Hanging the Head: Portraiture and Social Formation in Eighteenth-Century England*. New Haven, Conn.: Yale University Press, 1993.
- Ribeiro, Aileen. *The Art of Dress: Fashion in England and France, 1750 to 1820*. New Haven, Conn.: Yale University Press, 1995.

Pamela Church Gibson

**ADINKRA** Adinkra cloth is the traditional funerary dress of the Asante peoples of Ghana as well as many of their neighbors. Funerals are among the most lavish of all Asante ritual occasions and are clearly part of their still strong commitment to venerating their ancestors. The scholar J. B. Danquah defines the meaning of adinkra as, "to part, be separated, to leave one another, to say good-bye." Adinkra cloths are distinguished by designs applied with carved gourd stamps and a black dye placed within a rectilinear grid whose divisions are created by a three or four tine comb brushed in measured segments across the length and width of the cloth. Some cloths may feature a single stamped design while others may have over twenty different motifs applied to the surface.

For a cloth to be called adinkra, it must have these stamped designs. If the cloth is to serve as mourning dress, it must be dyed one of three colors—red, russet brown, or a dark blue-black. The latter is not typically stamped. Some sources state that the red adinkra is reserved for the closest members of the family and others assert that this is the role of the brown cloths. Clearly practices vary. Adinkra cloths that remain white or are printed on a brightly colored fabric are designated "Sunday adinkra," and are not used during funerals, but rather as festive dress for a variety of special occasions much like kente cloth.

The earliest known adinkra cloth (now in the British Museum) dates from 1817 and consists of twenty-four handwoven strips of undyed cotton cloth, each about three inches wide and woven on the same type of narrow strip horizontal treadle loom as Asante kente. The strips are sewn selvage to selvage (finished edges of a fabric) to produce a large men's cloth draped over the body toga style with the left shoulder covered and the right exposed. Women wear two pieces, one as a skirt and one as an up-



**Asante boys going to a dance in adinkra robes, 1973, Accra.** Color is important in adinkra garments; darker hues are reserved for funerary dress, while white or brightly colored garments are used for festive occasions. © OWEN FRANKEN/CORBIS. REPRODUCED BY PERMISSION.

per wrapper or shawl. In the early 2000s the latter piece is more frequently fashioned into a blouse.

The use of pieced-together narrow strips of a fixed width undoubtedly influenced the compositional divisions of the cloth as well as the size of the earliest stamps. By the end of the nineteenth century, however, imported industrially produced mill-woven cloth had largely replaced the handwoven strip weaves. Also about this time, the British were producing mill-woven cloth with roller-printed adinkra patterns for the West African market.

An additional design feature on many adinkra cloths is a further division of the men's cloths along their lengths with bands of multicolored whip-stitched embroidery in combinations of yellow, red, green, and blue. As seen in an 1896 photograph of the then king of Asante, Agyeman Prempeh I, this practice dates to at least the end of the nineteenth century. The embroidery is usually straightedged along the length of the cloth, but an important variant has serrated edges in a design called "centipede" or "zigzag." Although not necessarily referring to adinkra, the Englishman Thomas Bowdich observed this

practice in 1817. On some cloths multicolored handwoven strips about one and a half inches in width are substituted for the embroidery.

It is generally accepted that the adinkra genre was heavily influenced from the very beginning by Islam and in particular by Arabic inscribed cloths that are still produced by the northern neighbors of the Asante. These share a similar gridlike division of space and a number of hand-drawn motifs that are readily recognizable as adinkra patterns. Some of the same design principles and motifs are also found on Islamic inspired cast brass ritual containers called *kuduo*. The Asante attraction to the spiritual efficacy of Islam and to literacy in Arabic has been well documented since the early part of the nineteenth century. Significantly, an Arabic-inscribed cloth is still part of the wardrobe of the current king of Asante. The argument here is that the stamped adinkra cloth was developed as a shorthand for the more labor intensive and explicitly literate Muslim cloths.

Of particular interest in the study and appreciation of adinkra is the rich design vocabulary found on the



**Man preparing adinkra cloth, 1995, near Kumasi, Ghana.** The gridlike patterns and hand-drawn motifs of adinkra dress are similar to those found on many Arabic-inscribed fabrics and artifacts. © MARGARET COURTNEY-CLARKE/CORBIS. REPRODUCED BY PERMISSION.

stamps. Until the middle of the twentieth century, there were about fifty frequently repeated motifs. As with most Asante arts, there is a highly conventionalized verbal component to the visual images. The meaning of many motifs is elucidated by generally well-known proverbs. A design with four spiraling forms projecting from the center represents the maxim: “A ram fights with his heart and not his horns,” suggesting that strength of character is more important than the weapons one uses. A fleur-de-lis-shaped stamp is identified as a hen’s foot and is associated with the saying: “The hen’s foot may step on its chicks, but it does not kill them,” that is a mother provides protection and guidance and not harm. A stamp depicting a ladder depicts the inevitable, “The ladder of death is not climbed by one man alone.” Perhaps the most common motif is an abstract form that represents what is generally translated as: “Except God,” but its sense is better conveyed by “Only God.” As with most of their arts, the worldview of the Ashanti is wonderfully articulated in this funerary fabric.

In the twenty-first century, the corpus of stamp designs has expanded to well over five hundred. These include numerous references to the modern world, including automobiles, hydroelectric power, and cell phones. A number of motifs depict the logos of an assortment of Ghanaian political parties that have contended for power since independence (hand, cock, elephant, and cocoa tree). Another trend is a series of stamps that literally spell out their messages. For example, “EKAA NSEE NKOA” carved into a gourd stamp references a longer proverb that translates as: “The woodpecker celebrates the death of the *onyina* tree.” Since the bird nests and feeds in the dead tree, this is a kind of cycle-of-life statement. This practice recalls the origin of adinkra in script-filled, handwritten (albeit Arabic) inscribed cloths.

As with Asante kente, the verbal component of adinkra imagery is an important factor in its popularity in African American communities. Roller printed mill-woven adinkra is nearly as commercially successful as machine-made kente and appears in many of the same clothing forms, including hats, bags, scarves, and shawls. Individual adinkra motifs have even transcended clothing forms to become an important element in graphic design, fine arts, and even architecture.

See also **Africa, North: History of Dress; Africa, Sub-Saharan: History of Dress; Kente.**

#### BIBLIOGRAPHY

- Glover, Ablade. *Adinkra Symbolism*. Accra: Liberty Press, 1971. This one sheet chart/poster, reprinted many times, remains the most accessible reference for adinkra. It can be found in many African American bookstores and museums.
- Mato, Daniel. *Clothed in Symbol: The Art of Adinkra Among the Akan of Ghana*. Ann Arbor, Mich.: UMI Dissertation Services, 1987. Ph.D. dissertation is still the most comprehensive study of adinkra to date.
- Rattray, Robert S. *Religion and Art in Ashanti*. Oxford: Clarendon Press, 1927. Chapter 25 is the first substantial reference to adinkra and is still worthwhile.
- Willis, W. Bruce. *The Adinkra Dictionary: A Visual Primer on the Language of Adinkra*. Washington, D.C.: The Pyramid Complex, 1998.

Doran H. Ross

**ADIRE** *Adire* is a resist-dyed cloth produced and worn by the Yoruba people of southwestern Nigeria in West Africa. The Yoruba label *adire*, which means “tied and dyed,” was first applied to indigo-dyed cloth decorated with resist patterns around the turn of the twentieth century. With the introduction of a broader color palette of imported synthetic dyes in the second half of the twentieth century, the label “adire” was expanded to include a variety of hand-dyed textiles using wax resist batik methods to produce patterned cloth in a dazzling array of dye tints and hues.



### The Art of Making Adire

The traditional production of indigo-dyed adire involves the input of two female specialists—dyers (*alaro*), who control production and marketing of adire, and decorators (*aladire*), who create the resist patterns. In the oldest forms of adire, two basic resist techniques are used to create soft blue or white designs to contrast with a deeply saturated indigo blue background. *Adire oniko* is tied or wrapped with raffia to resist the dye. *Adire eleko* has starchy maize or cassava paste hand-painted onto the surface of the cloth as a resist agent. Further experimentation led to two additional techniques. *Adire alabere* involves stitching the cloth with thread prior to dyeing to produce fine-lined motifs. *Adire batani* is produced with the aid of zinc stencils to control the application of the resist starch.

The decorator works with a 1 x 2-yard fabric rectangle as a design field, making two identical pieces to sew together to make a square cloth most commonly used for a woman's wrapper. Most wrappers have repeated all-over patterns created with one or more resist techniques with no one focal point of interest. The motifs used in adire and the labels attached to them reflect the concerns of indigenous and contemporary Yoruba life: the world of nature, religion, philosophy, everyday life and notable events (Wolff 2001). Decorators, when not working with stencils, have a mental template in mind based on prototypes where particular motifs are combined together to identify a wrapper type, such as *Ibadandun*. Some motifs are pictographic, but often bear little resemblance to the thing signified by labels. For example, tie-dyed motifs such as "moon and fruits" have only a passing semblance to what they portray, while some motifs used in adire eleko like *ejo* (snake) or *eve* (leaf) are recognizable.

### The History of Adire

As a distinctive textile type, adire first emerged in the city of Abeokuta, a center for cotton production, weaving, and indigo-dyeing in the nineteenth century. The prototype was tie-dyed *kijipa*, a handwoven cloth dyed with indigo for use as wrappers and covering cloths. Female specialists dyed yarns and cloth and also refurbished faded clothing by re-dyeing the cloth with tie-dyed patterns. When British trading firms introduced cheap imported cloth and flooded the market with colorful inexpensive printed textiles, the adire industry emerged to meet the challenge. The women discovered that the imported white cotton shirting was cheaper than handwoven cloth and could be decorated and dyed to meet local tastes. The soft, smooth texture of the import cloth, in contrast to the rough surface of *kijipa* cloth, provided a new impetus for decoration. The soft shirting encouraged the decorators to create smaller more precise patterns with tie-dye methods and to use raffia thread to produce finely patterned stitch-resist adire *alabere*. The smooth surface of shirting led to the development of hand-painted starch-resist adire *eleko*. Abeokuta remained the major producer and

trade center for adire, but Ibadan, a larger city to the north, developed a nucleus of women artists who specialized in hand-painted adire *eleko*. The wrapper design *Ibadandun* ("Ibadandun" meaning "the city of Ibadan is sweet") is popular to this day.

In the early decades of the twentieth century, a vast trade network for adire spread across West Africa. Adire wrappers were sold as far away as Ghana, Senegal, and the Congo (Byfield 2002; Eades 1993). At the height of adire production in the 1920s, Senegalese merchants came to Abeokuta to buy as many as 2,000 wrappers in one day from the female traders (Byfield 2002, p. 114). In the 1930s, two technological innovations to decorate adire were developed that provided an avenue for men to gain entrance into the female-controlled industry. Women retained the dyeing specialty and continued to do tying, hand-painting, and hand-sewing to prepare the cloth for dyeing, but decorating techniques involving sewing machine stitching and applying starch through zinc stencils were taken up by men, because West Africans believe that men have an affinity for machines and metal that women do not. A regional and international economic decline at the end of the 1930s led to a decline in the craft, so that in the 1940s no major innovations in production occurred (Byfield 2002; Keyes-Adenaike 1993). The European restriction placed against exporting cloth to West Africa during World War II (1939–1945) also had negative effects. Following the war, the adire industry was dealt a further blow when the markets were flooded with low-priced printed cloth from European, Asian, and African textile mills. By the 1950s adire production had significantly slowed, and few young people were being trained in the craft.

In the 1960s, while rural women were still wearing the indigo-dyed wrappers, urban dwellers considered it "a poor people's cloth" (Byfield 2002, pp. 212–218). However, the 1960s marked a new period of innovation in handcrafted cloth production in Yorubaland. With the growing availability of chemical dyes from Europe, there was a revolution in color and techniques (Keyes-Adenaike 1993, p. 38). Adire patterns caught the eye of Nigerian fashion designers who adapted the designs to print high-quality cloth using imported color-fast dyes in colors other than indigo. Sold by the yard the "new adire" was used for clothing, tablecloths, bedspreads, and draperies (Eicher 1976, pp. 76–77). One expatriate woman, Betty Okuboyejo who lived in Abeokuta, is credited with introducing high-quality adire-inspired cloth using a full range of commercial color-fast dyes to expatriates and Nigerian elites (Eicher 1976, p. 76). New multicolored adire utilized a simple technology and became a backyard industry so that the markets filled with the new adire. This modern form of cheaply produced adire, dubbed "kampala" (because it became popular at the time of the Kampala Peace Conference to settle the Biafra War in Nigeria) was manufactured by individuals with no prior knowledge of dyeing—farmers, clerks, petty traders, and

the jobless (Picton 1995, p. 17). Hot wax or paraffin was substituted for the indigenous cassava paste as a resist agent, and designs were created by simple techniques including tie-dye, folding, crumpling, and randomly sprinkling or splashing the hot wax onto a cloth prior to dyeing. As demand grew and the new adire makers began to professionalize, a block printing technique to apply the hot wax developed and largely supplanted stenciling (Picton 1995, p. 17).

In the twenty-first century, the new colorful adire continues to meet fashion challenges and to be an alternative to machine prints. In continually changing patterns, new adire appeals to the fashion-conscious Yoruba in the urban and rural areas. In Nigeria one can still buy indigo-dyed adire oniko and eleko made by older women in Abeokuta and Ibadan and by artisans at the Nike Center for the Arts and Culture in Oshogbo where the artist Nike Davies-Okundaye trains students in traditional adire techniques. But, increasingly, the lover of indigo-dyed adire must turn to collecting pieces from the cloth markets such as Oje Market in Ibadan or from traders who specialize in the old cloth. Soon those also will be gone from the Yoruba scene.

See also **Africa, North: History of Dress; Dyeing; Indigo; Tie-Dyeing.**

#### BIBLIOGRAPHY

- Barbour, Jane, and Doug Simmonds, eds. *Adire Cloth in Nigeria*. Ibadan: The Institute of African Studies, University of Ibadan, 1971. Excellent source on dyeing technology, history, and motifs.
- Beier, Ulli, ed. *A Sea of Indigo: Yoruba Textile Art*. Enugu, Nigeria: Fourth Dimension Publishing, 1997. Social history of adire, particularly contemporary conditions.
- Byfield, Judith. *The Bluest Hands: A Social and Economic History of Women Dyers in Abeokuta (Nigeria), 1890–1940*. Portsmouth, N.H.: Heinemann, 2002. A definitive history of the peak years of adire production.
- Eades, J. S. *Strangers and Traders: Yoruba Migrants, Markets, and the State in Northern Ghana*. Edinburgh, London: Edinburgh University Press for the International African Institute, 1993.
- Eicher, Joanne Bubolz. *Nigerian Handcrafted Textiles*. Ile-Ife: University of Ife Press, 1976.
- Keyes-Adenaike, Carolyn. *Adire: Cloth, Gender, and Social Change in Southwestern Nigeria, 1841–1991*. Ph.d. diss., University of Wisconsin, 1993.
- Oyelola, Pat. "The Beautiful and the Useful: The Contribution of Yoruba Women to Indigo Dyed Textiles." *The Nigerian Field* 57 (1992): 61–66.
- Picton, John. *The Art of African Textiles: Technology, Tradition and Luxe*. London: Barbican Art Gallery, Lund Humphries Publishers, 1995.
- Picton, John, and John Mack. *African Textiles*. London: British Museum Publications Ltd., 1979.
- Wolff, Norma H. "Leave Velvet Alone: The Adire Tradition of the Yoruba." In *Cloth Is the Center of the World: Nigerian Textiles, Global Perspectives*. Edited by Susan J. Torntore,

51–65. St. Paul, Minn.: Goldstein Museum of Design, Dept. of Design, Housing, and Apparel, 2001. An anthropological approach to production and cultural importance of adire.

*Norma H. Wolff*

**ADRIAN** Adrian, the great American film and fashion designer, was born Adrian Adolph Greenberg in Connecticut in 1903. Stage-struck at an early age, he had worked in summer stock and sold costume sketches to the producers of a Broadway show by the time he was eighteen. In 1921 he entered the New York School of Fine and Applied Arts (now the Parsons School of Design) to study stage design. He transferred to the Paris branch of the school in 1922.

Adrian returned to New York after three months to design costumes for Irving Berlin's *Music Box Revue*. He had designed costumes for his first movie and a number of Broadway shows by 1924, when he accepted a job designing costumes for Rudolph Valentino. Relocating to Los Angeles with Valentino, Adrian created costumes for three more of his films. He freelanced on *Her Sister from Paris*, starring Constance Talmadge, in 1925 and on Howard Hawks's *Fig Leaves* for Fox in 1926, a film that featured a two-color Technicolor fashion show sequence. Adrian signed a contract with Cecil B. DeMille the same year, moved with DeMille to Metro-Goldwyn-Mayer (MGM) in 1928, and subsequently signed with MGM. He stayed there until 1941, when he terminated his contract and left the movie business. In 1939 Adrian married Janet Gaynor, winner of the first Academy Award for best actress, and they had one son.

As MGM's chief designer, Adrian designed costumes for all the major stars in every important movie. Greta Garbo, Norma Shearer, Joan Crawford, Jean Harlow, Jeanette MacDonald, and Katharine Hepburn all wore his designs. Adrian was so important to the stars that Joan Crawford once said he should have been given cobilling on her movies. Film costumes had to make the stars look their best, be suitable for the character, and conform to the technical dictates of lighting, film stock, and sound recording. Period costumes had to be reasonably authentic but also accessible to the audience's eye. Modern wardrobes had to be of their time but independent of any specific fashion, for several reasons. First, the time lag between the production of a movie and its release meant that using current styles on a star would make her look out of fashion when the film was released months later. More important, each star's screen persona was carefully developed by the studio, and her roles never varied widely from it. For example, Norma Shearer represented the conservative-young-woman type; Garbo was always the unpredictable, mysterious exotic; and Joan Crawford typified sophisticated young America.

Film styles had influenced fashion since the silent movie era, but their impact was intensified by the advent



of sound. With the “talkies,” films became more realistic, and film costuming became less focused on theatrical effects. The European fashion world watched to see what Adrian put on Garbo, Shearer, and Crawford. Designs that Adrian introduced on individual stars frequently returned to America as “the latest from Paris.”

The studios allowed manufacturers to market garments based on a star’s film wardrobe, and thousands of dresses, blouses, and coats named for *Letty Lynton* (Joan Crawford, 1932) or *Queen Christina* (Greta Garbo, 1933) were sold. A number of Garbo’s hats—the cloche from *A Woman of Affairs*, the plumed cap from *Romance*, and the pillbox and turban from *Painted Veil*—created new trends.

In 1930 the Modern Merchandising Bureau was established to organize the manufacture of styles introduced in a film before the picture’s release, in order to have copies available in stores as soon as audiences saw the movie. Macy’s in New York was the first store to open a Cinema Fashions shop, and crowds would gather on the sidewalk to see the new styles in the display windows. During the Great Depression, Hollywood further capitalized on film fashions by licensing patterns for home sewing based on them. The success of Condé Nast’s *Hollywood Pattern Book* led to its becoming a whole new magazine, *Glamour of Hollywood*, in 1939; the title was subsequently shortened to *Glamour*. Movies exerted an enormous influence on world fashion, and Adrian was the leading Hollywood designer of his era.

After retiring from films, Adrian opened a couture and ready-to-wear business in Beverly Hills, which manufactured his designs and sold them to specialty stores throughout the United States. He showed his first collection in February 1942. Having designed suit variations for years in his movies on stars from Garbo to Hedy Lamarr—but most famously on Joan Crawford—he now produced the classic, square-shouldered, 1940s suit for which he is best known. Antecedents of this “V” silhouette throughout the 1930s had included such devices as the pagoda shoulder and the horizontal extension of the sleeve cap through pleating. To avoid both the faddish effect of the pagoda shoulder and the boxiness of the widened sleeve cap, Adrian squared the shoulder with pads of his own design, narrowing and neatening the silhouette to give it a classic line. As well as suits, he included a wide variety of day dresses, cocktail and evening wear, and coats in his collections.

In 1947 Adrian refused to follow the example of Paris when the New Look was introduced by Christian Dior. He found sloping shoulders, a cinched waist, padded hips, and long, full skirts unattractive on the average woman as well as cumbersome and impractical. Although he never significantly varied the “V” cut of his suits, he reduced the shoulder pads in his suits—never removing them altogether—and lengthened and slimmed the skirt. For evening wear, as opposed to daytime, Adrian had no quarrel with the New Look and encouraged women to

go “all out.” His wartime evening silhouette—a neoclassic column of rayon crepe with the same slim, squared shoulders as his suits—mutated into a softer silk sheath. Adrian’s evening collections expanded to include everything from voluminous ball gowns to variations on the sari to dinner dresses draped with bustle variations.

Throughout the collections of Adrian’s fashion career, certain themes reappeared. He frequently designed prints of animals, such as the famous “Roan Stallion” evening gown or *The Egg and I* at-home dress with its furious barnyard chickens. After Adrian’s trip to Africa in 1949, animal and reptile prints appeared in a ball gown of tiger-skin taffeta and a hooded evening suit made from heavy silk that looked like an iridescent python skin. His “Americana” theme included a quilted silk hostess gown appliquéd with cotton gingham motifs and a long gingham evening coat with a matching skirt and sequined bodice. He referenced modern art movements such as futurism with inset streamers that emerged from the gown’s surface to drape and flutter and cubism in the extraordinary “Modern Museum” series of rayon crepe gowns executed in pieced, multicolor, biomorphic shapes. In 1952 Adrian suffered a heart attack that forced him to close his business. He died in 1959.

Adrian’s career was unique among designers in that he conquered both the film and fashion worlds. He worked entirely in California, far off the beaten track for couture or ready-to-wear. In film he worked as a couturier, designing costumes to highlight a star’s individuality and conceal her figure flaws. These singular creations in turn engendered worldwide fashion trends. After leaving films his greatest achievement lay in his mastery of the ready-to-wear market. As a film designer Adrian gave fashion inspiration and hours of entertainment to millions of people all over the world. As a fashion designer he set a standard both for originality of design and quality of workmanship.

See also **Actors and Actresses, Impact on Fashion; Costume Designer; Film and Fashion; Hollywood Style; Ready-to-Wear.**

#### BIBLIOGRAPHY

Gutner, Howard. *Gowns by Adrian*. New York: Harry N. Abrams, 2001.

Lee, Sarah Tomerlin, ed. *American Fashion: The Life and Lines of Adrian, Mainbocher, McCardell, Norrell, and Trigère*. New York: Quadrangle/New York Times Book Company, 1975.

*Jane Trapnell*

**AESTHETIC DRESS** In 1851, London celebrated the Great Exhibition, showcasing the latest innovations in manufacture and design. Its warm reception by the public and the media confirmed, in many people’s eyes,

the triumph of increased industrialization and mass production. However, some, who found this way of life increasingly abhorrent, sought an alternative lifestyle by looking to the past.

Three years earlier, in 1848, the young artists William Holman Hunt, John Everett Millais, and Dante Gabriel Rossetti established the Pre-Raphaelite Brotherhood, taking inspiration from the art of the late medieval and early renaissance periods, which they felt produced a purer and more naturalistic style. As such, dress played an important role in the depiction of the subjects, but with no extant examples, references came from tomb effigies, illustrated manuscripts, and the artist's own inventions. The type of dress that emerged was worn by female members of the artists' circle.

Early styles of aesthetic dress took the form of flowing fabric with soft pleating falling from the neckline. The folds then gently gathered in at the natural, uncorseted waistline and fell into a small train at the back. The sleeves were a defining feature; unlike those of fashionable dress, they were set at the natural shoulder line and often decorated with puffs of fabric at the sleeve head, or gathered down the length of the arm. This enabled freedom of movement, as did the abandonment of the corset, which was felt to offer a more natural figure along the lines of the Venus de Milo, although critics noted "had Venus herself been compelled by a cold climate to drape herself, we have little doubt she would have worn stays, to give her clothes the shape they lacked" (Douglas, pp. 123–124). As such, the style found favor with dress reformers who spoke out against the damaging effects of tightly laced corseting. The two movements became closely allied and by 1890 the Healthy and Artistic Dress Union was established, publishing their ideas in their journal *Aglaia*.

Color was an all important element of the style, with soft browns, reds, blues, and—a popular choice and most recognizable of them all—a sage green, which was often referred to as "greenery yallery." Aesthetic dress was relatively unadorned, the only decoration appearing in the form of smocking or floral and organically inspired embroidery, with the sunflower and the lily being popular motifs. Accessories were kept to a minimum, with amber beads seen as the most appropriate choice, along with eastern or oriental-inspired pieces. The aesthetic woman herself was epitomized by the red-haired, pale-skinned beauties with their defined jawlines and sorrowful eyes as seen in Rossetti's *La Ghirlandata* (1877). A photograph of Jane Morris, the wife of the designer William Morris, taken in 1865, depicts her as the perfect embodiment of this ideal. Her untamed hair is loosely tied back, her dress draping in heavy folds.

By the 1870s, the style had really come to the attention of the public. In 1877, Mrs. Eliza Haweis published her book *The Art of Beauty* in which she outlined the drawbacks of contemporary fashion and commended

the lines of historical dress. She was approached in 1878 by the ladies magazine *The Queen* to write some articles on the subject of Pre-Raphaelite dress. *The Queen* reported: "A great change has come over the style of English dressing within the last, say, five years. . . . The world of artists first started the idea of their wives and daughters dressing in harmony with . . . [their] surroundings, and thence the grandes dames of fashion were influenced" (pp. 139–140).

As fashion conscripted artistic dress, historic periods were plundered with a myriad of styles indiscriminately thrown together under the term "aesthetic"; Greek tunics, medieval sleeves, and Elizabethan ruffs became popular adornments for fashionable dress. The Watteau-back dress, a partly fashionable style, was characterized by a large pleat of fabric falling loosely from the shoulders and caught up above the hem; it was inspired by eighteenth-century sacque dresses, depicted in the works of Watteau. These styles were a feature of the tea gown, a loose informal garment that could be worn at home or while receiving guests for afternoon tea.

The year 1877 also saw the opening of the Grosvenor Gallery and the first of the satirist George Du Maurier's series of cartoons, published in *Punch*, and based around a family known as the Cimabue Browns. The images portrayed the wearers of aesthetic dress as lank and languid men and women—the men in velvet jackets and long hair, the ladies with frizzed hair in long drooping garments—who always seemed to be contemplating the emotional impact of art on life.

The International Exhibition held in London in 1862 had stimulated the growing interest in oriental and exotic foreign goods. Arthur Lasenby Liberty, a young employee of Farmer and Roger's Shawl Emporium in Regent Street, persuaded his employers to open an oriental department. Owing to its huge success, Liberty left to set up his own department store in 1875. His imported fabrics and unusual artifacts were extremely popular with many artists, such as George Frederick Watts, James Whistler, and Frederick Leighton, who frequented the shop. Liberty soon began to produce his own fabrics suitable to the English climate yet with the qualities and colors of imported Eastern examples. In 1884, he opened a dressmaking department, overseen by E. W. Godwin, an architect and honorable secretary of the Costume Society. Godwin had designed many of the costumes for his partner, the famous actress Ellen Terry, whose choice of aesthetic dress was well known.

In 1881, the aesthetic craze was at its height with the production of Gilbert and Sullivan's *Patience* and the start of Oscar Wilde's lecture tours in America. His lectures included the importance of Liberty to the aesthetic movement and, as Alison Adburgham notes, this could "be said to have sown the first seeds that germinated into the long love affair between the Americans and Liberty's of London" (pp. 32–33).



*May Morning, Jane Morris, taken by J. Robert Parsons.* The heavily draped, unadorned dress, minimal accessories, and sorrowful expression are all typical of aesthetic fashion. © STAPLETON COLLECTION/CORBIS. REPRODUCED BY PERMISSION.



The aesthetic movement had a popular following in America, the most noted proponent being Annie Jenness Miller who published *Dress: The Jenness Miller Magazine*. The society painter W. P. Frith captured the aesthetic scene in his painting *Private View* (1881), which depicted many of the leading proponents of the movement, such as Wilde and Ellen Terry. In his memoirs of 1887, Frith recalled,

Seven years ago certain ladies delighted to display themselves at public gatherings in what are called aesthetic dresses; in some cases the costumes were pretty enough, in others they seemed to rival each other in ugliness of form and oddity of color (p. 256).

This telling quote also illustrates how aesthetic dress was now somewhat passé. Many of its elements had entered the mainstream, with the popularity of the tea gown and the ready availability of “artistic dress” in most department stores. A guide to London of 1889 recommends Hamilton’s of Regent Street for “those triumphs of needlework: smocked frocks and smocked tea gowns. But it is by no means only in so-called artistic dress that they excel” (Pascoe, p. 351). By the turn of the century, aesthetic dress was no longer seen as radical or revolutionary. While its themes may have lingered in the work of early twentieth-century designers, such as Mariano Fortuny, whose pleated fabrics seem directly inspired by the dress worn in Rosetti’s painting *A Vision of Fiammetta* (1878), or the draped velvets of Maria Monaci Gallenga, the sumptuous sophisticated style of art nouveau had captured the artistic imagination, and the soft muted colors and trailing drapery of aesthetic dress were considered *démodé*.

See also **Art and Fashion**; **Fortuny, Mariano**; **Wilde, Oscar**.

#### BIBLIOGRAPHY

- Aldburgham, Alison. *Shops and Shopping*. London: George Allen and Unwin Ltd., 1964.
- . *Liberty: A Biography of a Shop*. London: George Allen and Unwin Ltd., 1975.
- Costume: The Journal of the Costume Society* 1 (1967), 2 (1968), 13 (1979), 21 (1987).
- Douglas, Mrs. J. *The Gentlewoman’s Book of Dress*. London: Henry and Company, 1895.
- Frith, W. P. *My Autobiography and Reminiscences*. Vol. 2. London: Richard Bentley and Son, 1887.
- Haweis, Eliza. *The Art of Beauty and The Art of Dress*. New York and London: Garland, 1978.
- MacDonald, Margaret F., et al. *Whistler, Women and Fashion*. New Haven, Conn.: Yale University Press, 2003.
- Newton, Stella Mary. *Health, Art and Reason: Dress Reformers of the 19th Century*. London: John Murray, 1974.
- Pascoe, Charles Eyre. *London of Today: An Illustrated Handbook for the Season*. London: Hamilton Adams and Company, 1889.
- Punch*. 14 September 1878, 9 April 1881, 30 April 1881.
- The Queen*. 24 August 1878.
- Squire, Geo. *Dress, Art and Society*. London: Macmillan, 1974.

Thieme, Otto Charles, E. A. Coleman, M. Oberly, and P. Cunningham. *With Grace and Favour: Victorian and Edwardian Fashion in America*. Cincinnati, Ohio: Cincinnati Art Museum, 1993.

Oriole Cullen

**AFRICAN AMERICAN DRESS** African American dress intertwines with the history of Africans, who arrived in the Virginia colony in 1619. Within that century, southern codes forced the children of any enslaved woman to remain enslaved for life. West Africans continued to come unwillingly until the 1830s. President Abraham Lincoln proclaimed the emancipation of all enslaved peoples in 1863; but after the Civil War, African Americans lived on the margins of American society with poor jobs, substandard living and educational conditions, disenfranchisement, and public segregation. Nearly one hundred years later, in 1954, a Supreme Court decision began the desegregation process and in the 1960s, Federal legislation gave equal rights to African Americans.

Under enslavement, white owners demanded a certain form of dress for those in bondage: better dress for house servants and managers; poorer attire for field hands, children, and those too old to continue working. In spite of these constrictions, the nineteenth-century autobiographies and narratives, collected in the 1930s from formerly enslaved people, relate that African Americans put a great deal of thought into their dress. The narrators emphasized what clothing they had and did not have and described the clothing styles they desired and how they obtained them. “Correct” dress was especially important when “stepping out” for social occasions with community members, a habit that continues in the early 2000s. Narrators offered vivid depictions of dressing well for church, dances, and marriage.

Evidence shows that some retained West African forms of bodily adornment, particularly in the form of jewelry. From the African Burial Ground (1712–1795) in New York City, the remains of an adult female and an infant wore waistbeads as do West African women. Archaeological evidence from known slave sites sometimes includes cowries, seashells of economic importance before currencies became available in Africa and apparently worn as jewelry by the enslaved. The beads most often found at these sites consist of blue glass beads, worn as amulets in much of Africa and the Middle East. Former slaves provided testimony of wearing jewelry for both adornment and protection. Several Sea Islands narrators, for instance, describe single gold, loop earrings worn to protect the eyesight, retention of an African belief.

More outstanding as an African holdover than specific items of jewelry or clothing has been the interest in hairstyle and headwear by African American men and women. Documentation for West Africans’ concern for well-groomed hair and ornamented heads is long-



**Headwraps.** Beginning in the 1960s, African American women began wearing traditional headwraps as an acknowledgment of their West African ancestral roots. This fashion trend, among others, became popular with white Americans as well. © BJ FORMENTO/CORBIS. REPRODUCED BY PERMISSION.

standing and survives among African Americans. Black men continue to sport ever-changing styles of facial hair and hairdos; the “conk” (straightened hair that is flattened down or slightly waved) of the 1930s remains a primary example. And, into the early twenty-first century, African American men consistently wear some type of headgear.

African American women also show a marked interest in their hairstyles and headwear. The slave narratives explain various ways of styling hair even under the most adverse conditions. Photographs of prominent women after the Civil War show them wearing the elegant, long, straight hairstyles in general fashion at the time. In 1906, this processing of the natural hair texture into straight hair spread across the country when Madame C. J. Walker began to market her highly profitable hair formula for managing African American women’s hair. Black

women also choose to wear hats, especially prevalent for church attendance.

With one exception, portraits from the eighteenth and nineteenth centuries, and nineteenth-century photographs, of African Americans show them wearing dress appropriate in general society. The exception is the African American woman’s headwrap, the oldest extant specific dress item of any immigrant group worn in the early 2000s. But over time, its meaning changed.

In the antebellum South, several states legally enforced the code that ordered black women to wear a cloth head covering in public and not the hats and feathers worn by white women. These codes thus marked certain females as a subservient class. During enslavement, women working in onerous conditions wore the head wrap to keep the hair cleaner and to absorb perspiration. Use of the head wrap at home continued after the Civil

War, but for public wear it was discarded. Beginning with the civil rights movement of the 1960s and 1970s, the head wrap took on other meanings. Young African American women again tied elaborate head wraps around their heads and publicly wore them in acknowledgment of their enslaved ancestors and as a reference to Africa and the way West African women adorn their heads.

During the civil rights movement, along with the head wrap, other young black revolutionaries adopted what they perceived to be West African attire, such as caftans and male head caps. Men and women grew their hair into enormous styles called “Afros,” allowing for the natural texture to be emphasized in direct reaction against conks and Walker’s straightening products that attempted to simulate European hair. Since the 1960s, some black men have continued to look back to Africa by wearing Rasta locks while black women have their hair intricately braided into elaborate African styles, often adding hairpieces.

African Americans generally have dressed in the prevailing fashions along with other Americans. Portraits of early black clergymen offer examples. Slave narrative frontispieces, however, illustrate the author in either slave clothing or formally dressed as a freed person, the choice obviously expressed what the author wanted to portray about his or her place in society. After the invention of photography, the images of eminent leaders such as Frederick Douglass and Booker T. Washington always show them dressed in formal, gentleman’s clothing. Between 1895 and 1925, black intellectuals, literati, and artists strove to present themselves as quite different from the racist stereotypical cartoon illustrations of “Mammys” and “Sambos” drawn by whites. Many illustrations show these “New Negroes” groomed and adorned in conservative, mainstream dress.

Although African Americans adopted the prevailing cultural dress of each period, their style often sets them apart. For instance, travelers’ accounts about the South prior to emancipation describe African Americans’ dress as more flamboyant and colorful than that of whites. Contemporary African Americans similarly prefer to be well dressed for most occasions and have not adopted the white population’s sartorial trends to casual and even sloppy dress.

In general, American fashions came from Europe until about 1950. But at the same time, black styles began to influence white American dress, particularly men’s; for example, the zoot suit of the 1940s, highlighted by the popular singers Billy Eckstein and Frank Sinatra. In the 1960s, expensive, stylized brands of tennis shoes, first worn by professional African American athletes, notably basketball players, were adopted by the larger, adolescent community. In the 1990s, white, suburban youth began wearing the hip-hop clothing first worn by young, urban, black males. And in the early twenty-first century, white males wear the doo rag, for decades the African American male’s inner-city hair tamer.

Since the mid-1950s, African Americans have become part of the greater American cultural scene. And, in a very real sense, this larger society in the early 2000s adopts African American culture in many aspects of life, not the least in styles of dress.

See also **Afro Hairstyle; Afrocentric Fashion; Ethnic Dress; Zoot Suit.**

#### BIBLIOGRAPHY

- Cunningham, Michael, and Craig Marberry. *Crowns: Portraits of Black Women in Church Hats*. New York: Algonquin Books of Chapel Hill, 2001.
- Foster, Helen Bradley. *“New Raiments of Self”: African American Clothing in the Antebellum South*. Oxford: Berg, 1997.
- . “African American Jewelry Before the Civil War.” In *Beads and Bead Makers: Gender, Material Culture and Meaning*. Edited by Lidia D. Sciana and Joanne B. Eicher 177–192. Oxford: Berg, 1998.
- Gates, Henry Louis, Jr. “The Trope of the New Negro and the Reconstruction of the Image of the Black.” *Representations* 24 (Fall 1988): 129–155.
- Genovese, Eugene. “Clothes Make the Man and the Woman.” In *Roll, Jordan, Roll: The World the Slaves Made*, 550–561. New York: Pantheon Books, 1974.
- Rawick, George P., ed. *The American Slave: A Composite Autobiography*. Westport, Conn.: Greenwood, 1972, 1977, 1979.
- Starke, Barbara M., Lillian O. Holloman, and Barbara K. Nordquist, eds. *African American Dress and Adornment: A Cultural Perspective*. Dubuque, Iowa: Kendall/Hunt, 1990.
- White, Shane, and Graham White. *Stylin’: African American Expressive Culture*. Ithaca, N.Y.: Cornell University Press, 1998.

Helen Bradley Foster

**AFRICA, NORTH: HISTORY OF DRESS** North Africa comprises Egypt and the lands to its west, known in Arabic as al-Maghrib, literally “the place of sunset”: Libya, Tunisia, Algeria, and Morocco. These political divisions were essentially established by the Ottomans in the sixteenth century, but throughout history this part of Africa has been affected by, and has had a profound effect upon, the regions that surround it: the Mediterranean, sub-Saharan Africa, and the Middle East. It is impossible to appreciate one region without knowing something of the history of all; the style and patterning of dress provides one means of reading that history.

#### History, Geography, and Climate

The climate and topography of North Africa is extraordinarily varied. The peaks of the High Atlas mountains of Morocco tower over 13,000 feet, whereas oases in the depressions of the Libyan Desert descend to sea level or below. The mild, temperate conditions of the Mediterranean and Atlantic coasts give way to the searing daytime heat and freezing nighttime temperatures of the



desert lands to the south. Crops and vegetation thrive on the fertile northern plains and along the Nile valley, whereas scarcely anything grows in the desert save in the lush oases where the water table is close to the surface.

Ancient Egyptian art gives us a fairly detailed picture of how people in this part of North Africa dressed, at least as far back as 5000 B.C.E. Elsewhere, the extraordinary rock paintings of the Sahara, the Atlas Mountains, and the Nile valley, dating from c. 12000 to 3000 B.C.E., give us an idea of how people might have dressed when the interior of North Africa had a much wetter climate, supporting animals such as hippos, elephants, giraffes, and rhinos.

In the ninth century B.C.E., Carthage was founded near the modern city of Tunis; the Carthaginians traded cloth and other luxury goods across the Sahara in exchange for slaves, gold, and ivory, a pattern continued by the Romans following the sacking of Carthage in 146 B.C.E., only declining when the Portuguese and other Europeans began to trade along the west coast of Africa in the fifteenth century. Roman mosaic pavements from Carthage show garments that bear a remarkable similarity to tunics worn in the early twenty-first century as part of a woman's wedding costume in the Tunisian town of Mahdia.

In the seventh century, Muslim armies invaded North Africa and began the process that, despite resistance from the indigenous Berber peoples, culminated in the establishment of the Hispano-Moresque civilization; this society flourished in the Maghrib countries and southern Spain until the fall of Granada to Christian armies in 1492. After that event, many Muslim and Jewish artisans, including weavers and embroiderers, sought refuge in the large towns of North Africa, and at this point, a particular pattern of production, use of materials, and division of labor, which has remained essentially unchanged, was established.

### Town and Country

Walk through the marketplace in any North African town, from Cairo to Marrakech, and at first glance you will find people dressed no differently than city dwellers in any other part of the world. Many male professionals and office workers wear a suit and tie, or possibly some version of the "safari" suit. Many women wear an equally conventional two-piece top and skirt, though most wear the *Hijab*, the Islamic head covering. Younger people of both sexes wear jeans, T-shirts, or football shirts. Among these now ubiquitous "Western" garments, however, people wear more obviously local fashions. Many working men in Cairo wear *djellaba*, the long, loose-fitting gown, sometimes in combination with the *kaffiyeh*, a turbanlike head cloth or cotton skullcap; older women may wear *burqa* and *bedla*, a black headscarf and flowing dress. In Tunisian towns, the red felt *chechija*, a cross between skullcap and beret, is still the single most distinctive item of male attire, while in much of the Maghrib the burnoose, a hooded cloak, is worn by many men.

In rural regions, the cut and sewn garments of the city tend to be replaced by single-piece draped or wrapped clothes for women, secured by a fibula, or cloak pin. Berber women of the Atlas Mountains of Morocco wear elaborate headdresses on certain occasions, whereas men may wear large woolen cloaks or knitted "long johns" while herding their flocks during the winter. So-called "granny" dresses—often featuring "foreign" elements such as cuffs, collars, pockets, and pleated hems—are commonly worn by women in rural communities of North Africa. Variations on this style, based on European dresses of the eighteenth and nineteenth centuries, may be found in many other parts of the world, including the islands of the Pacific Ocean. However, the costumes worn for special occasions, particularly marriage, emphasize the real differences between town and country styles.

### Marriage Costume

In North Africa, as in all Muslim societies, marriage is seen as the ideal adult state. Clothing for both bride and groom reflects their new social status as well as concerns over modesty and fertility; perhaps most importantly, clothing is seen to ease transition from the unmarried to the married state. As elsewhere in postcolonial Africa, the popularity of "traditional" attire has fluctuated according to political, religious, and economic circumstances. The dictates of fashion and the desire to appear modern has made the white European wedding dress a popular choice, though often dress designers have come up with styles that incorporate something old and something new, thus satisfying the desire to be both fashionable and culturally aware.

The names of certain wedding garments in North Africa suggest one or more of the ceremonies marking the different days of the marriage festivities; for example, *mwashma* (painted), an elaborately embroidered dress from the village of Raf Raf in Tunisia, evokes the *laylat al-benna*, or "night of henna," when the bride and groom are tattooed with henna to bless their marriage and encourage the birth of children.

The simple, T-shaped cotton tunics worn by the bride in Siwa, Egypt; Ghadamis, Libya; and Mahdia, Tunisia, probably share a common ancestry with certain garments that appear in the mosaics of Roman Carthage. These loose-fitting, yet elaborately decorated dresses are designed to show off the status and beauty of the bride while preserving her modesty; they can also accommodate up to seven more garments beneath them, which are revealed to the bride's and then to the groom's relatives during the *jikwa* ceremony.

### The Significance of Pattern

Similar patterns are known by different names in different regions of North Africa and do not necessarily have the same significance. However, universal concerns regarding protection from harm—and, by extension, promoting

good luck, health, and fertility—are preoccupations that inform the patterning of artifacts throughout the region.

Concerns about the harmful effects of envy, focused in beliefs surrounding the evil eye, are often manifest in the form of patterning applied to marriage costume in particular, though such designs may perform a host of additional functions. The *bakbnuq*, a marriage shawl from southern Tunisia, is woven in a combination of wool and cotton that, when dyed, reveals the white cotton motifs resistant to dye. These motifs suggest items of jewelry and the pattern of women's tattoos, but also snakes' vertebrae and sharp cloak pins to repel or pierce the evil eye. The different colors of the *bakbnuq* traditionally indicate women's status: young, unmarried girls wear white; married women of child-bearing age don red, while older women wear black or blue.

The wedding dresses of women from the oases in the Western Desert of Egypt, with the exception of the oasis of Siwa, display unmistakable similarities to the embroidered dresses of Palestine, reflecting a long historical connection between the two regions. In the 2000s these dresses are only worn by older women, but they still display the very distinctive patterning, color, and style of embroidery peculiar to each oasis, and sometimes even to individual villages within the same oasis. The embroidered bodices of these dresses, embellished with numerous sequins and sometimes small coins to deflect the evil eye, are a certain way of establishing the identity and affiliation of the wearer. For example, the bodices of dresses from Bahriya oasis are invariably made up of rectangular areas of embroidery with distinctive tassels on the shoulders and chest; the dresses of Daqahliya oasis, by contrast, have a quite different pattern of embroidery on the bodice, with a central section tapering to a point.

The patterning applied to male clothing reflects similar concerns. The woolen tunics, *gandura*, woven by women for their sons in the remote M'zab region of southern Algeria include named motifs, such as "birds with their young" and "a table of guests," emphasizing fertility and harmony; other motifs, such as forks and weaving combs, have the added dimension of sharp implements with the ability to pierce the evil eye.

### Dress as Historical Document

The patterning, color, style, and design of dress and textiles in North Africa suggest clues that, through painstaking research, can be pieced together to provide a more detailed and reliable picture of the past than any written record. Few, if any, of the distinctive features of dress happen by accident or whim; many tell of the movements of people through warfare, religious persecution, trade, economic necessity, or natural disaster. Often this story goes back many centuries, perhaps reaching outside both the region and even the African continent, each event being recorded in a series of details that have gradually evolved into the form of modern dress.

The machine-embroidered wedding dresses worn by women of the Jewish faith in urban Morocco are developments of the elaborate, hand-embroidered dresses of the nineteenth century. These in turn can be traced back to Spanish styles of the late Hispano-Moresque period, brought to Morocco by Jewish craftsmen expelled from Andalusia during Christian persecution of the fifteenth and sixteenth centuries. These craftsmen settled not just in Morocco, but in major urban centers throughout the Maghrib. From the sixteenth century, Ottoman influence began to spread throughout the region, and many of the floral motifs that appear on textiles, such as the *tansbifa* of Algeria, and the '*ajar* and *rida'* *abmar* of Tunisia, are of Turkish inspiration. The first two are no longer worn, but the *rida'* *abmar* remains the most prestigious item of clothing worn by women of the town of Mahdia. At each end of this silk wedding veil is a set of design bands woven in silk and gold thread. The central band known as *dar-al-wust* (literally "the house in the middle") represents a mosque in stylized form; at the other end of the cloth, the *dar-al-wust* features two motifs in the form of the Star of David, an element of the design that continues to be included by the Muslim weavers out of respect for the Jewish weavers who once produced this garment.

Female weavers in the old silk-weaving town of Naqâda, in the Nile valley of Egypt, produce a style of shawl that has a similarly complex history. Using a tapestry weave technique widely practiced in Damascus and elsewhere in the Levant, male weavers of the nineteenth century produced the *aba*, a man's gown, as well as other garments such as the cotton and silk modesty garment worn by women of Bahriya oasis in Egypt's Western Desert until it began to go out of fashion in the mid-twentieth century. In recent years a collective of female weavers, taking over what had previously been an exclusively male profession, began to weave this shawl, using the same looms and weaving techniques, but in gaudy, two-tone rayon, rather than in silk and cotton. Their new markets were initially in Libya and Sudan, but when these dried up following political differences between the three countries, the women found other outlets in the tourist trade in Cairo from where these textiles are today exported to various European countries.

Distinctive ceremonial costumes continue to be produced by weavers and embroiderers in different parts of North Africa, displaying the dynamism with which textile traditions throughout Africa have developed since antiquity. Despite the clear influences that have helped to shape North African cultures, an internal dynamic has molded these elements into the distinctive material culture characteristic of each region.

See also **Africa, Sub-Saharan: History of Dress; Burqa; Djellaba; Hijab; Kaffiyeh; Textiles, African.**

### BIBLIOGRAPHY

Besancenot, Jean. *Costumes of Morocco*. London and New York: Kegan Paul, 1990. Detailed paintings and drawings made



by French artists working in Morocco during the 1930s; text in English.

- Cuenot, Joel, ed. *Noces tissées, noces brodées: Parures et costumes féminins de Tunisie*. Paris: Editions Joel Cuenot, 1995. Exhibition catalog (text in French) with useful essays and many color photographs of traditional Tunisian female costume and jewelry.
- Reswick, Irmtraud. *Traditional Textiles of Tunisia*. Los Angeles: Craft and Folk Art Museum and University of Washington Press, 1985. Survey of Berber textiles from rural Tunisia, including many technical details of weaving.
- Rugh, Andrea. *Reveal and Conceal: Dress in Contemporary Egypt*. Cairo: American University in Cairo Press, 1987. In-depth study of the social significance of costume, both male and female, in late twentieth-century Egypt; numerous black and white illustrations.
- Spring, Christopher, and Julie Hudson. *North African Textiles*. London: British Museum Press, 1995. Survey of the region, with additional information on Sudan and Ethiopia, and with an emphasis on the symbolic and social significance of dress; draws on the British Museum's collections and the fieldwork of staff and colleagues.
- . "Urban Textile Traditions of Tunisia." *African Arts* (forthcoming). Fieldwork-based article detailing the production and use of urban costume in Tunisia, 1997–1998; many color photos of weavers and embroiderers and their products; also refers to Tunisian contemporary artists working in the medium of textiles.
- Stone, Caroline. *The Embroideries of North Africa*. London: Longman, 1985. Separate sections on Tunisia, Algeria, and Morocco as well as Turkish embroideries and their influence on North Africa; useful technical information on stitches and applications.

*Christopher Spring*

## AFRICA, SUB-SAHARAN: HISTORY OF DRESS

African dress, like dress everywhere, communicates age, gender, occupation, ethnicity, power, and religious commitment for everyday, celebratory, ceremonial, and ritual occasions. Along with fashionable Western dress, Africans wear Islamic and indigenous apparel. Dress involves totally or partially covering the body by supplementing it with apparel and accessories such as head wraps and jewelry and modifying the body itself with tattoos or piercing. Dressing well for Africans involves proper conduct and elegant style, which includes appropriate apparel, cosmetics, and coiffure along with magnificent carriage, graceful movement, fastidious toilette, and immaculate garments.

African dress worn every day indicates socially significant categories, but may also express personal idiosyncrasy. When Africans wear identical dress, such as uniforms or garments made from the same fabric, their garb emphasizes group affiliation and minimizes individuality. African dress is not the same as African costume. Actors and masqueraders temporarily conceal personal identity through costume, whereas in everyday life peo-

ple communicate and reveal their personal identity through dress.

African dress is as varied and diverse as the historical antecedents and cultural backgrounds of the African people in fifty-five countries and more than eight hundred linguistic groups. A continent two-and-a-half times as large as the continental United States, the physical environment of Africa ranges from the deserts of the Sahara and the Kalahari, to the mountains of the Great Rift Valley, and the rain forests in West and Central Africa, as well as the arid region of the Sahel that borders the Sahara. What African people wear relates to these factors of physical environment, to external and internal trade and migration, to the influences of explorers, missionaries, and travelers and to their own creativity. Specific information about the dress of each ethnic group comes from social, religious, and political histories, as well as oral, archaeological, trade, and mercantile records. Early evidence of dress is depicted in the rock art of northern, southern, and eastern Africa, indicating items of dress that predate contact with European, Asian, and Middle Eastern peoples. Tellem caves in Mali provide cloth fragments that give evidence of hand woven apparel before Saharan trade or coastal contacts.

In the twenty-first century, dress in Africa includes items fashioned from local resources and tools, such as wrappers hand woven from handspun cotton threads on handmade looms in the West African countries of Sierra Leone, Mali, and Nigeria. In addition, combinations of local resources and imported materials are used, as seen in the kente wrappers woven from imported rayon or silk threads on locally made looms in Ghana. African dress also includes imported items from worldwide sources made by complex machines and techniques (British top hats and homburgs, French designer gowns, Italian shoes and handbags, and Swiss laces along with secondhand clothing from the United States) from commercially produced materials. In addition, Africans produce their own designer garments from both imported and locally made textiles and also transform imported secondhand clothing into locally admired fashions. Some African designers, like the Malian, Xuly Bët, left Africa to become successful in Paris, New York, and elsewhere.

Purely indigenous items are becoming less common and therefore less often worn. Borrowed items are often creatively used and juxtaposed with other items that result in a readily identifiable ethnic style. The Kalabari-Ijo people, from the delta area of the Niger River in Nigeria, combine a variety of textiles and other items of dress that are imported from elsewhere in Nigeria and abroad. Their dress illustrates the term "cultural authentication," which designates adopted articles that are selected, characterized by symbolic representation, incorporated, and transformed. For example, the Kalabari-Ijo man's ceremonial hat, called *ajibulu*, stems from the European military and naval officers' bicorne hat from

the late eighteenth and early nineteenth centuries. The Kalabari decorate a hat of this shape with hair from a ram's beard along with tiny mirrors, small, shiny Christmas ball ornaments, brightly colored feathers, and plastic hair clasps, each glued or stitched onto the basic fabric, resulting in a head covering that is uniquely Kalabari.

African residents who come from European and Asian ancestry may choose not to wear African items of dress; instead, they maintain forms of dress fashionable in the countries of their ancestors. Indian women whose families have lived in East and West Africa for several generations continue to wear the sari as commonly worn on the Indian subcontinent. In South Africa, Afrikaansers wear European dress that continues their European heritage. In contrast to those who refrain from wearing African items, some non-Africans embrace them: Peace Corps volunteers from the United States in Nigeria found the Yoruba *dansiki* (more commonly known in the United States as "dashiki") a handsome and comfortable shirt to wear. Tourists, too, often buy and wear African beads, hats, cloth, garments, and fans while travelling and take them home as souvenirs.

### Dressing the Torso

The torso is usually the focus when dressing the body, although headwear and footwear are also significant. Items of dress generally may be classified as enclosing, attached, or hand held. Enclosing dress can be subdivided into wraparound, preshaped, and suspended categories; all examples are found in Africa. Wraparound garments are formed from rectangular pieces of fabric that are folded, crushed, or twisted around the body. Preshaped items include cut and sewn garments along with other items, such as jewelry, that are molded or cast. Most attached and many suspended enclosing items of dress are also jewelry, such as earrings and necklaces. Handheld items usually consist of accessories such as a fan, purse, cane, or walking stick. Throughout Africa, both men and women wear variations of the wrapper (also called *kanga*, *futa*, *lappa*, or *pagne*). As a garment, the loose fit of wrap-around apparel seems particularly appropriate and comfortable to wear because of prevalent high temperatures, both dry and humid. Wrappers are also easily made from available materials such as skins, bark (or bark cloth), or wool, cotton, silk, and raffia for handwoven cloth. Preshaped garments for men and women in general came from contact with Europeans and Middle Easterners, as women adopted dresses and gowns and men adopted jackets, shirts, and trousers as clothing styles. African women and girls rarely wore pants or other bifurcated garments until jeans and pants became fashionable for women in Europe, America, and Japan, thus beginning an influence on young African women especially to adopt these styles for many occasions.

The wrapper, however, is probably the most frequent and popular indigenous garment in sub-Saharan Africa. Women may wrap cloth from their waist to their knees,

calves, or feet. Sometimes they wrap the cloth under the armpits to cover their breasts and lower body. Men ordinarily wrap a small length of cloth from their waist to their feet, with the chest either bare or covered. For both men and women in the twenty-first century, a bare chest is not frequently seen in public, but remains an option for dressing informally at home. Non-Muslim Africans were influenced by European ideas of modesty after many countries became independent in the 1960s, because they discovered that journalists and outsiders commented negatively on African "nudity," usually referring to bare-breasted women. In fact, some Nigerian municipalities passed laws at that time specifically forbidding women to enter the town if they were bare-breasted.

Examples of wraparound garments abound. In Ghana, Asante men wear handwoven *kente* togas; in Ethiopia, Amharic women don handwoven shawls of sheer, white cotton; in Nigeria, Yoruba women garb themselves in indigo resist-dyed wrappers; in Zaire, the Kuba dress in raffia skirts. Other examples include several from southern Africa: Ndebele and Xhosa women wrap commercially made blankets around themselves, and Zulu men wrap skin aprons. Both sexes among the Baganda in Uganda traditionally wore bark-cloth wrappers, as did the Masai of Kenya and Somalis from the Horn of Africa; some continue the practice today. Masai warriors, depending on their geographical location, wear a wrapper that is either below the knee or very short, sometimes wrapping it around the waist and at other times wrapping it across one shoulder. Those warriors wearing short wrappers are said to choose that style to show off their handsome bodies. Masai women wear a skirt or cloth wrapped around their waist as well as a blanket or cloth wrapped over their shoulders. Somali people wore leather garments of their own making before the 1800s, but imported cotton textiles quickly made inroads and included several options of wrapping the body for both men and women, depending on the occasion and the weather.

For festive, ritual, or ceremonial occasions, Ghanaian men wear a well-known example of an African wrap-around garment similar to the Roman toga. They take a large rectangle of cloth, sometimes as large as six yards square, depending on the size of the man, and wrap it full-length around the body with one shoulder uncovered. This style became internationally visible in the 1960s when the first president of Ghana, Kwame Nkrumah, wore it and was photographed in it for ceremonial occasions, both at home and abroad.

Preshaped dress involves cutting and sewing lengths of cloth to make a garment fit the body. Common styles are shirts, blouses, robes, and pants, or the Hausa man's *baba riga* (big gown). Cross-cultural contacts influenced the design of many preshaped garments. The colonial impact and trade contacts of the late nineteenth and early twentieth centuries are seen in several women's gowns.

For example, the long gown (called *boubou*) made popular by Wolof women in Senegal indicates probable Muslim and Middle Eastern origins, whereas the gowns of Herero women in Namibia, Efik women in Nigeria, and the “granny” gown of women in Egypt show nineteenth-century European contact.

Men’s trouser shapes vary considerably. Along with Western fashions found across the continent, indigenous fashions also abound. In Nigeria, Hausa men wear enormously large drawstring breeches with a “*baba riga*” over the top. Yoruba men wear both wide or narrow trousers, often as a three-piece outfit along with a robe (*agbada*) and shirt (*dansiki*). When the men’s ensemble is tailored from colorful, wax-printed cotton, the Yoruba outfit is interpreted as being informal. If made from damask, lace, eyelet, brocade, or the handwoven textile of nubby, native silk that the Yoruba call *sanyan* (produced by a different silk worm than the Asian one), the ensemble is considered formal.

Throughout Africa, males wear preshaped shirts and hip-length or calf-length garments with trousers or wrappers. Finishing and decorating details distinguish many of the garments as being associated with one ethnic group or another. In the Republic of Benin, Fon men’s ensembles include a heavily embroidered, sleeveless tunic pleated at the neckline and flared at the hipline that they combine with embroidered trousers and an embroidered cap. In Cote d’Ivoire and Ghana, Mandinka and Akan men wear garments known as war shirts and hunters’ shirts. Amulets decorate these garments and are made of animal horns, claws, teeth, or packets that contain slips of paper with magical or mystical words written on them.

Enclosing garments include suspended and combination forms. Some hats are suspended by being perched on top of the head and many items of jewelry are suspended around the neck or wrist. Capes (often worn by Hausa and Fulani emirs and other royalty) are combination forms. Preshaped and stitched, they are also loosely suspended from the shoulders.

Items held by or for a person complete an African ensemble. As accessory items, these include umbrellas, canes, walking sticks, purses, handbags, fans, switches, handkerchiefs, linguist staffs, and tusks, as well as weapons such as daggers, swords, and spears. Many materials are used for these items. An individual carries an umbrella for protection from rain or as a substitute for a cane. Attendants for a ruler carry large, decorative, and colorful umbrellas to emphasize the ruler’s position and significance, for a ruler should not be so encumbered. Canes and walking sticks are made of wood, ivory, or plastic; fans, of paper, leather, hide, or feathers. Fashionable handbags are commercially manufactured; some are produced domestically while others are imported. When wearing an indigenous ensemble, an individual often carries a bag crafted from indigenous materials, such as domestically produced leather that is also dyed,

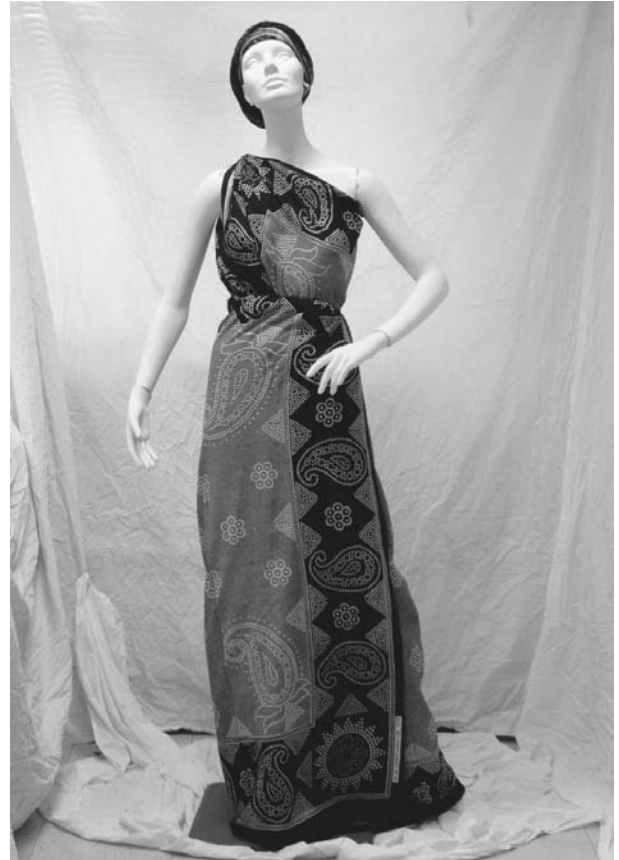

**African wrapper.** The wrapped garment is probably the most frequently worn by Africans of both sexes, as its comfortable, loose fit is the best suited to the humid environment. PHOTOGRAPH BY HEATHER MARIE AKOU, PERSONAL COLLECTION. REPRODUCED BY PERMISSION.

painted, or decorated with beads. An ivory elephant’s tusk held by an important individual indicates high status and wealth.

Many types of body modifications and jewelry also dress the torso. Tattooing occurs among light-skinned people, like the North African Berbers, because tattoos do not show on dark skin. Instead, permanent markings in the form of scarification and cicatrization or temporary cosmetics (ochre, kaolin, indigo, henna, and chalk) decorate dark-skinned bodies. Many permanent-marking procedures began to die out in the twentieth century as Africans became exposed to Western cosmetic and body decoration practices, and interest grew in looking “modern.” Cosmetics familiar to Westerners are easily available throughout Africa, although not always worn or used plentifully. Again, the issue relates to varieties of skin color, for lipstick and blush are not as visible on dark complexions as on light-colored ones. Similarly, henna—a common cosmetic in North Africa and the Middle East—is not used by Africans with darker skin, although it is sometimes used on the palms and bottom of the feet,



which are lighter parts of the body. Both men and women wear scented products, but frequently, African men wear stronger scents than found among most European and American men. European perfumes and scents can be purchased throughout Africa, but prohibitive prices preclude wide usage. Instead, indigenous products are available and used, as in the case of Muslim women who stand over incense burners to scent their clothing with the fragrant smoke.

Africans display many kinds of jewelry. Items for the torso include necklaces, armlets, bracelets, and anklets of many types, along with items that circle the waist, such as “waist beads.” Necklaces vary in size and style, from large to small, fashioned from metals, beads, shells, chains, and medallions. Some bracelets and anklets are modest in size, circling only the wrist and ankle with metal or beads. Others are massive, used to adorn the lower arm, upper arm, or lower leg with coils of copper or chunks of ivory. Materials used for body ornaments include gold, silver, brass, copper, ivory, natural stones like jasper, coral, and amber, and many cowrie shells (which often decorate garments as well). Both imported and locally produced glass beads exist throughout Africa. Italy, Austria, and Germany historically exported glass beads to all areas of Africa, and artisans in towns (Bida, Nigeria, for example) produce glass beads from recycled beverage bottles. Both Masai men and women wear necklaces of imported, colorful beads that look like wide collars and rest on the back of the neck. Some Masai children wear miniature examples of these beaded necklaces as well as beaded bracelets and anklets. Small disk shapes cut from ostrich shells or celluloid are used for waist beads worn by women and girls in West Africa. These beads are decorative and also sexually attractive in intimate situations. Some make sounds that attract attention when the individual moves.

Color, texture, or fabric motif distinguishes the dress of different peoples. All types of textiles exist from imported natural and synthetic yarns along with domestic ones of cotton, wool, silk, and synthetics. Favorite fabrics include plain broadcloth, lace, eyelet, damask, brocade, and velvet. Suppliers are generally located in Africa, but import sources include the United Kingdom and such European countries as the Netherlands and Switzerland. Asian sources include Japan, China, and India, where manufacturers cater to African preferences for specific textile motifs and colors. Fashions in material, design, and color change over time, but preferences for muted and somber colors can often be found in some countries, bright and saturated colors in others, and dazzling whites or pastels in still others. A printed textile used for wrappers in Tanzania and Kenya known as *kanga*, domestically produced in the early 2000s, has a distinct pattern. Ordinarily, the colors are bright green, yellow, orange, and red. The cloth is printed in repeat motifs that include a motto or saying. These written messages communicate political or social points of view. Somali men

and women have used imported cloth for their wrappers for many years. Records from the nineteenth century indicate that one type, an inexpensive white cotton, was called *merikani* because it was imported from the United States. Another imported blue fabric worn during the same period, came from the Indian city of Surat to be used by married women as a head wrap.

Identical textiles worn for special events by a large number of people are popular in various locations. An entire community or special group may honor significant people (usually political) by having their portrait screen-printed on a commercially manufactured textile or T-shirt. Other times, members of the group select a special color or pattern of either handwoven or commercial cloth to wear. The custom of wearing identical cloth is known as *aso ebi* (family dress) and *aso egi* (association dress) among the Yoruba of Nigeria, where it apparently began. Other groups, the Ibo of Nigeria, for example, have adopted the custom and call their identical dress “uniforms.” Techniques to decorate garments include embroidery, beading, and appliqué. Various robes worn by men throughout West Africa are heavily embroidered; simpler embroidery is seen on some of the contemporary gowns worn by women, caftans or boubous, especially those being made for the tourist market in the early twenty-first century. Beading is found on robes of some royalty; sequins and beads decorate women’s blouses, for example among the Yoruba and Kalabari-Ijo. Appliqué is often used for ceremonial attire, masquerade garb, and trappings for horses.

### Hair Styles and Headwear

Stylish coiffure, headwear, and appropriate cosmetics often complete African ensembles of dress, and in addition provide information about gender, age, political position, or community standing. Hairstyles vary across the continent. Braiding (sometimes called plaiting or weaving) the hair and twisting are common as well as combing the hair in sections to produce a pattern on the scalp after the sections are braided or bound with thread. Wigs are worn, fashionable ones for every day, made from synthetic or human hair, as well as older types, made from indigenous fibers, for special ceremonies. Older customs also included adding oil, ochre, or mud to give textural and sculptural effects to the hair. Headwear is made from indigenous as well as imported materials including textiles, skins, feathers, straw, raffia, and beads. Children and youth wear headgear less often than adults do. Men’s headwear includes caps, hats, and turbans and in some areas exhibits greater variety in type than the head wraps (often called head ties) and other headwear of women. This may be related to a wider range of available positions in political and religious systems for men than women, such as chieftaincies and priesthoods. Men’s headwear includes many types of caps and hats from handwoven and hand-embroidered fabrics but, especially since the arrival of Europeans,



**Kalabari chief.** Beads, coral accessories, and elaborately ornamented headgear, such as the *ajibulu* crown shown here, are often worn by sub-Saharan Africans of elevated social or political status. © CAROLYN NGOZI EICHER. REPRODUCED BY PERMISSION.

men wear many styles of imported hats and caps. Opulent decorations for hats of high-status (often royal) men include embroidery with metallic threads of gold and silver or precious gems or metals. In some areas, men select an imported top hat, derby, or fedora as part of their dress ensemble, again indicating high status, whether born into the position or achieved by being granted a local honor or reaching a certain age. Veils and turbans may also be part of male dress. The wrapped white turban of a Hausa man shows that he has been to Mecca. The shiny, deep indigo-dyed veils worn by Tuareg males make them easily identifiable.

Adult females, particularly the Yoruba of Nigeria and Ndebele of Southern Africa, most often wear cloth head ties wrapped in numerous shapes and styles. Fashion changes as well as creativity and individual flair influence their head-tie arrangements. A highly desirable fabric for women's head ties in western Africa comes from a manufacturer in England, but women also select hand-woven cloth to match their wrapper set. An example of fashion change occurred among Herero women, who used skins for headwear in the 1800s, but use cloth in the early 2000s. Muslim women throughout Africa employ several

methods to cover their hair. Some cut and sew cloth to preshape a head covering or suspend fabric to create a veil that reveals only their eyes. Others loosely wrap fabric over their heads and tie or pin it under their chins. Some veiling garments, such as the burqa, were once worn only by Arab women living in Africa but have spread to other Muslim populations. Jewelry also decorates the hair and head for men and women, including earrings, hair ornaments, and headbands using the same beads, metals, precious and semiprecious gems, ivory, stones, fibers, and many natural materials to fashion them. Imported items like buttons also provide decoration.

#### Footwear

Footwear is often desired to complete a person's dress ensemble. During colonial periods, some Europeans did not allow shoes to be worn by those subservient to them, whether in the house or at work in colonial offices. Many styles of leather sandals, boots, and shoes are worn; these may be handmade or commercially manufactured, locally or abroad. Inexpensive rubber and plastic thongs are widely available for people who want to protect their feet in a minimal fashion and for minimal cost. In contrast,

men and women of special rank wear distinctive and expensive footwear decorated with beads, rare feathers, precious metals, or carefully worked designs in leather. For example, Hausa emirs in northern Nigeria display ostrich feathers on the insoles of their footwear to complement their royal gown and cape, and the horsemen in their royal entourage wear leather boots. In the south of Nigeria, rulers choose other footwear. The oba of Benin puts on slippers covered with coral beads as part of his ceremonial dress, and the royal ensemble of the Alake of Abeokuta includes colorful slippers covered with tiny imported glass beads.

### Conclusion

African dress may consist of a single item or an ensemble and range from simple to complex. Single items such as a hat, necklace, or waist beads contrast with the total ensemble of an elaborate gown or robe worn with a head covering, jewelry, and accessories. A wrapper, body paint, and uncomplicated hairdo exemplify a simple ensemble whereas a complex one combines several richly decorated garments, an intricate coiffure, opulent jewelry, and other items. Either single items or total ensembles may have an additive, cumulative character created by clusters of beads or layers of cloth or jewelry. As an individual's body moves, such clusters and layers are necessary components of dress that provides ambient noise with the rustle of fibers or fabrics and jingle of jewelry. A bulky body often indicates power and the importance of the individual's position, but slenderness is gaining popularity as young people travel to the West or see Western media. Impressiveness through bulk can be achieved by layering garments and jewelry or using heavy fabric. Examples are the elaborate robes of a ruler, such as the Asantehene of the Asante people in Ghana. On top of his robes, he adds impressive amounts of gold jewelry and presents himself in an ensemble expected by his subjects. Similarly, the customers of a successful and powerful market woman expect her to wear an imposing wrapper set, blouse, and head wrap. In many cases, middle-class and wealthy African men and women enjoy a wardrobe of many types of dress, selecting from a variety of Western pieces of apparel or from indigenous items. Such a wardrobe allows selection of an outfit to attend an ethnic funeral or ceremonial event in their hometown as well as dress in current fashions from Europe and America when traveling, studying abroad, or living or visiting in African cosmopolitan cities.

The wide range of color and style in African dress, headdress, and footwear reflects the reality that covering and adorning the body is used to provide both aesthetic and social information about an individual or a group. Aesthetically, individuals can manipulate color, texture, shape, and proportion with great skill. An individual's dress may express an individual's personal aesthetic interest or it may indicate membership in an ethnic, occupational, or religious group. Similarly, an individual's

dress conveys social information because specific expectations exist within groups for appropriate outfits for age, occupation, and group affiliation. Understanding the dress of the people who live on the large African continent means realizing that many complex factors contribute to choices that an African makes about what to wear at a particular time. To appreciate fully or depict accurately the dress of an individual African or of a specific African group of people, one needs to consult available social and historical records and contemporary scholarly information as well as African newspapers, magazines, television, and other media sources.

*See also Africa, North: History of Dress; Bogolan; Burqa; Dashiki; Indigo; Kanga; Kente; Pagne and Wrapper; Secondhand Clothes, Anthropology of; Textiles, African; Xuly Bët.*

### BIBLIOGRAPHY

- Allman, Jean. *Fashioning Africa: Power and the Politics of Dress*. Bloomington: Indiana University Press, 2004.
- Arnoldi, Mary Jo, and Chris Mullen Kreamer. *Crowning Achievements: African Art of Dressing the Head*. Los Angeles: UCLA Fowler Museum of Cultural History, 1995.
- Beckwith, Carol, and Saitoti Tepilit Ole. *Maasai*. New York: Harry N. Abrams, 1980.
- Clarke, Duncan. *African Hats and Jewelry*. New York: Chartwell Books, 1998.
- Daly, Catherine, Joanne Eicher, and Tonye Erekosima. "Male and Female Artistry in Kalabari Dress." *African Arts* 19 (3) (May 1986): 48–51.
- Eicher, Joanne, ed. *African Dress: A Select and Annotated Bibliography of Sub-Saharan Countries*. East Lansing: African Studies Center, Michigan State University, 1970.
- Fall, N'Goné, Jean Loup Pivin, Khady Diallo, Bruno Airaud, and Patrice Félix-Tchicaya. "Spécial Mode: African Fashion." *Revue Noire* 27 (December 1997, January–February 1998).
- Fisher, Angela. *Africa Adorned*. New York: Harry N. Abrams, 1984.
- Hendrickson, Hilde, ed. *Clothing and Difference: Embodied Identities in Colonial and Post-Colonial Africa*. Durham, N.C.: Duke University Press, 1996.
- Mertens, Alice, and Joan Broster. *African Elegance*. Cape Town, South Africa: Purnell and Sons, 1973.
- Murphy, Robert. "Social Distance and the Veil." *American Anthropologist* 56, no. 6 (1965): 1257–74.
- Perani, Judith, and Norma H. Wolff. *Cloth, Dress, and Art Patronage in Africa*. Oxford: Berg, 1999.
- Picton, John. *The Art of African Textiles: Tradition, Technology, and Luxe*. London: Barbican Art Gallery, 1996.
- Pokornowski, Ila, Joanne Eicher, Moira Harris, and Otto Thieme, eds. *African Dress: A Select and Annotated Bibliography*. Vol. 2. East Lansing: African Studies Center, Michigan State University, 1985.
- Rabine, Leslie W. *The Global Circulation of African Fashion*. Oxford: Berg, 2002.
- Sieber, Roy. *African Textiles and Decorative Arts*. New York: Museum of Modern Art, 1972.



van der Plas, Els, and Willemsen Marlous. *The Art of African Fashion*. Trenton, N.J.: Africa World Press, 1998.

*Joanne B. Eicher*

**AFRO HAIRSTYLE** At the end of the 1950s, a small number of young black female dancers and jazz singers broke with prevailing black community norms and wore unstraightened hair. The hairstyle they wore had no name and when noticed by the black press, was commonly referred to as wearing hair “close-cropped.” These dancers and musicians were sympathetic to or involved with the civil rights movement and felt that unstraightened hair expressed their feelings of racial pride. Around 1960, similarly motivated female student civil rights activists at Howard University and other historically black colleges stopped straightening their hair, had it cut short, and generally suffered ridicule from fellow students. Over time the close-cropped style developed into a large round shape, worn by both sexes, and achieved by lifting longer unstraightened hair outward with a wide-toothed comb known as an Afro pick. At the peak of its popularity in the late 1960s and early 1970s the Afro epitomized the black is beautiful movement. In those years the style represented a celebration of black beauty and a repudiation of Eurocentric beauty standards. It also created a sense of commonality among its wearers who saw the style as the mark of a person who was willing to take a defiant stand against racial injustice. As the Afro increased in popularity its association with black political movements weakened and so its capacity to communicate the political commitments of its wearers declined.

### Pre-Existing Norms

In the 1950s black women were expected to straighten their hair. An unstraightened black female hairstyle constituted a radical rejection of black community norms. Black women straightened their hair by coating it with protective pomade and combing it with a heated metal comb. This technique transformed the tight curls of African American hair into completely straight hair with a pomaded sheen. Straightened hair remained straight until it had contact with water. Black women made every effort to lengthen the time between touch-ups. They protected their hair from rain, did not go swimming, and washed their hair only immediately before straightening it again. If a woman could not straighten her hair, she covered it with a scarf.

The technology of hair straightening served prevailing gender norms that defined long wavy hair as beautifully feminine. While hair straightening could not lengthen hair and may have contributed to breakage, it transformed tightly curled hair into straight hair that could be set into waves. Tightly curled hair was disparaged as “nappy” or “bad hair,” while straight hair was praised as “good hair.” The Eurocentric underpinnings

of these black community judgments have led many to characterize the practice of hair straightening as a black attempt to imitate whites. Cultural critics have countered by arguing that hair straightening represented much more than an imitation of whites. Black women modeled themselves after other black women who straightened their hair to present themselves as urban, modern, and well groomed.

In the post–World War II period, when the vast majority of black women straightened their hair, most black men wore short unstraightened hair. The male straightened hairstyle that was known as the conk was highly visible because it was the style favored by many black entertainers. The conk, however, was a rebellious style associated with entertainers and with men in criminal subcultures. Conventional black men and men with middle-class aspirations kept their hair short and did not straighten it.

### Origins

In the late 1950s and early 1960s, awareness of newly independent African nations and the victories and setbacks of the civil rights movement encouraged feelings of hope and anger, as well as exploration of identity among young African Americans. The Afro originated in that political and emotional climate. The style fit with a broader generational rejection of artifice but more importantly, it expressed defiance of racist beauty norms, rejection of middle-class conventions, and pride in black beauty. The unstraightened hair of the Afro was simultaneously a way to celebrate the cultural and physical distinctiveness of the race and to reject practices associated with emulation of whites.

Dancers, jazz and folk musicians, and university students may have enjoyed greater freedom to defy conventional styles than ordinary working women and were the first to wear unstraightened styles. In the late 1950s a few black modern dancers who tired of continually touching-up straightened hair that perspiration had returned to kinkiness, decided to wear short unstraightened hair. Ruth Beckford, who performed with Katherine Dunham, recalled the confused reactions she received when she wore a short unstraightened haircut. Strangers offered her cures to help her hair grow and a young student asked the shapely Miss Beckford if she was a man.

Around 1960, in politically active circles on the campuses of historically black colleges and in civil rights movement organizations, a few young black women adopted natural hairstyles. As early as 1961 the jazz musicians Abbey Lincoln, Melba Liston, Miriam Makeba, Nina Simone and folk singer Odetta were performing wearing short unstraightened hair. Though these women are primarily known as performing artists, political commitments were integral to their work. They sang lyrics calling for racial justice and performed at civil rights movement rallies and fund-raisers. In 1962 and 1963



**Activist Angela Davis, without and with an Afro.** By the late 1960s, the Afro was less frequently associated with black political movements, but the notoriety of Davis caused many to refer to the Afro as the “Angela Davis look.” © BETTMANN/CORBIS. REPRODUCED BY PERMISSION.

Abbey Lincoln toured with Grandassa, a group of models and entertainers whose fashion shows promoted the link between black pride and what had begun to be called variously the “au naturel,” “au naturelle,” or “natural” look. When the mainstream black press took note of unstraightened hair, reporters generally insinuated that wearers of “au naturelle” styles had sacrificed their sex appeal for their politics. They could not yet see unstraightened hair as beautiful.

### Early Reactions

Though they received support for the style among fellow activists, the first women who wore unstraightened styles experienced shocked stares, ridicule, and insults for wearing styles that were perceived as appalling rejections of community standards. Many of these women had conflicts with their elders who thought of hair straightening as essential good grooming. Ironically, a few black female students who were isolated at predominantly white colleges experienced acceptance from white radicals who were unfamiliar with black community norms. More mainstream whites, however, saw the style as shockingly unconventional and some employers banned Afros from the workplace. As more women abandoned hair straightening, the natural became a recognizable style and a fre-

quent topic of debate in the black press. Increasing numbers of women stopped straightening their hair as the practice became emblematic of racial shame. At a 1966 rally, the black leader Stokely Carmichael fused style, politics, and self-love when he told the crowd: “We have to stop being ashamed of being black. A broad nose, a thick lip, and nappy hair is us and we are going to call that beautiful whether they like it or not. We are not going to fry our hair anymore” (Bracey, Meier, and Rudwick 1970, p. 472). The phrase “black is beautiful” was everywhere and it summed up a new aesthetic ranking that valued the beauty of dark brown skin and the tight curls of unstraightened hair.

Increasing numbers of activists adopted the hairstyle and the media disseminated their images. By 1966 the Afro was firmly associated with political activism. Women who wore unstraightened hair could feel that their hair identified them with the emerging black power movement. Televised images of Black Panther Party members wearing black leather jackets, black berets, sunglasses, and Afros projected the embodiment of black radicalism. Some men and many women began to grow larger Afros. Eventually only hair that was cut in a large round shape was called an Afro, while other unstraightened haircuts were called naturals.



### Popularization

As larger numbers of black men and women wore the Afro, workplace and intergenerational conflicts lessened. In 1968 Kent cigarettes and Pepsi-cola developed print advertisements featuring women with large Afros. Decorative Afro picks with black power fist-shaped handles or African motifs were popular fashion items. While continuing to market older products for straightening hair, manufacturers of black hair-care products formulated new products for Afro care. The electric “blow-out comb” combined a blow-dryer and an Afro pick for styling large Afros. Wig manufacturers introduced Afro wigs. Though the Afro’s origins were in the United States, Johnson Products, longtime manufacturer of hair-straightening products, promoted its new line of Afro Sheen products with the Swahili words for “beautiful people” in radio and print advertisements that stated “Wantu Wazuri use Afro Sheen.” In 1968 a large Afro was a crucial element of the style of Clarence Williams III, star of the popular television series, *The Mod Squad*. In 1969 British *Vogue* published Patrick Lichfield’s photograph of Marsha Hunt, who posed nude except for arm and ankle bands and her grand round Afro. This widely celebrated image fit with an emerging fashion industry pattern of featuring black models associated with signifiers of the primitive, wildness, or exotica.

One wearer of a large Afro was the activist and scholar Angela Davis who wore the style in keeping with the practices of other politically active black women. When, in 1970, she was placed on the FBI’s most wanted list, her image circulated internationally. During her time as a fugitive and prisoner she became a heroine for many black women as a wide campaign worked for her release. The large Afro became indelibly associated with Angela Davis and increasingly described as the “Angela Davis look.” Ironically the popularization of her image contributed to the transformation of the Afro from a practice that expressed the political commitments of dedicated activists to a style that could be worn by the merely fashion-conscious.

The style that became the Afro originated with black women. Since most black men wore short unstraightened hair in the late 1950s, short unstraightened hair could only represent something noteworthy for black women. When, in the mid-1960s, the style evolved into a large round shape, it became a style for men as well as women. Since black men customarily wore unstraightened hair, an Afro was only an Afro when it was large. During the late 1960s and early 1970s, when men and women wore Afros, commercial advertising and politically inclined artwork generally reasserted gender distinctions that had been challenged by the first women who dared to wear short unstraightened hair. Countless images of the era showed the head and shoulders of a black man wearing a large Afro behind a black woman with a larger Afro. Typically, the woman’s shoulders were bare and she wore large earrings.

### Declining Popularity and Enduring Significance

In the late 1960s the black radical H. Rap Brown complained that underneath their natural hairstyles too many blacks had “processed minds.” By the end of the decade many blacks would agree with his observation that the style said little about a wearer’s political views. As fashion incorporated the formerly shocking style, it detached the Afro from its political origins. The hair-care industry worked to position the Afro as one option among many and to reassert hair straightening as the essential first step of black women’s hair care. In 1970 a style known as the Curly Afro, which required straightening and then curling hair, became popular for black women. In 1972 Ron O’Neal revived pre-1960s subcultural images of black masculinity when he wore long wavy hair as the star of the film *Superfly*. Large Afros continued to be popular through the 1970s but their use in the era’s blaxploitation films introduced new associations with Hollywood’s parodic representations of black subcultures.

While the large round Afro is so strongly associated with the 1970s that it is most frequently revived in comical retro contexts, the Afro nonetheless had enduring consequences. It permanently expanded prevailing images of beauty. In 2003 the black singer Erykah Badu stepped onstage at Harlem’s Apollo Theater wearing a large Afro wig. After a few songs she removed the wig to reveal her short unstraightened hair. Reporters described her hair using the language employed by those who had first attempted to describe the styles worn by singer Nina Simone, Abbey Lincoln, and Odetta at the beginning of the 1960s. They called it “close-cropped.” Prior to the popularity of the Afro black women hid unstraightened hair under scarves. Through the Afro the public grew accustomed to seeing the texture of unstraightened hair as beautiful and the way was opened for a proliferation of unstraightened African American styles.

*See also African American Dress; Afrocentric Fashion; Barbers; Hair Accessories; Hairdressers; Hairstyles.*

### BIBLIOGRAPHY

- Bracey, John H., Jr., August Meier, and Elliott Rudwick, eds. *Black Nationalism in America*. New York: Bobbs-Merrill Company, 1970.
- Craig, Maxine Leeds. *Ain’t I a Beauty Queen: Black Women, Beauty, and the Politics of Race*. New York: Oxford University Press, 2002. Includes a detailed history of the emergence of the Afro.
- Davis, Angela Y. “Afro Images: Politics, Fashion, and Nostalgia.” *Critical Inquiry* 21 (Autumn 1994): 37–45. Davis reflects on the use of photographs of her Afro in fashion images devoid of political content.
- Kelley, Robin D. G. “Nap Time: Historicizing the Afro.” *Fashion Theory* 1, no. 4 (1997): 339–351. Kelley traces the black bohemian origins of the Afro and its transformation from a feminine to masculine style.
- Mercer, Kobena. “Black Hair/Style Politics.” In *Out There: Marginalization and Contemporary Cultures*, edited by Russell

Ferguson, Martha Gever, Trinh T. Minh-ha, and Cornel West, 247–264. Cambridge, Mass.: MIT Press, 1990. Mercer places the Afro in the context of earlier black hair care practices and challenges the widely held view that hair-straightening represented black self-hatred.

*Maxine Leeds Craig*

**AFROCENTRIC FASHION** An Afrocentric perspective references African history and applies it to all creative, social, and political activity.

### **Negritude and Afrocentricity**

Afrocentricity was founded in the 1940s when Aimé Césaire and Léopold Sédar Senghor, president of Senegal and poet, used the term “negritude” to describe the effects of Western colonization upon black people without any reference to their culture, language, or place. The most significant example of colonization was the Atlantic slave trade that started in the fourteenth century and lasted for 400 years. However, the effects of colonization have arguably caused Africa to become economically underdeveloped and culturally bereft. For the descendants of slaves living in Western countries Atlantic slavery had resulted in them experiencing disadvantage and intolerance, which was based upon their physical dissimilarity from the indigenous population. These points are at the kernel of Aimé Césaire and Léopold Sédar Senghor’s idea that negritude is defined by the physical state of the black person, which is blackness.

Afrocentrism gained gravitas when Cheikh Anta Diop (1974) argued that ancient Africans and modern Africans share similar physical appearances and other genetic similarities, as well as cultural patterns and language structures. Diop and others have used this insight to sponsor the idea of ancient Egypt (Kemet) as a black civilization and a reference point for modern Africans.

Frantz Fanon (1967) used the term “negritude” to illustrate the existence of black psychological pathologies that hindered black individuals from attaining liberation within Western modernism and the way all black people are affected by colonialism. An example of black psychological pathology in self-expression is found in the way fashion provides a visual backdrop to the engagement between mask and identity, image and identification. The purpose of fashion in the African setting is precise; it enables black individuals to attain status positions that are outside of their usual habitus. In doing so blacks use some of the visual tools of their oppression and liberation when creating their fashioned self image. Fanon provides a sketch of a black Caribbean man who arrives in the West after leaving his homeland. He leaves behind a way of life symbolized by the bandanna and the straw hat. Once in the West the man shifts into a position, which is manifest by his unease of existing in the West and perhaps from wearing Western clothes. Fanon’s rather harsh indictment offers blacks in the West only two possibilities,

either to stand with the white world or to reject it. This concept of negritude contributed to the conceptual basis of Afrocentrism.

### **Expression of Self**

The way that black people use apparel in personal representations of *self* may differ and be dependent upon location and perspective. Afrocentric fashion is analogous to Western fashion. Both appropriate much from oppositional fashion expressions; consequently both expressions are fragmented and perennially incomplete. Avid Afrocentrists reject the idea that Afrocentricism might be influenced or contain traces of Western culture, though it is perceptible that Afrocentric fashion is less absolute than other expressive forms, such as music and art.

In Africa and in the African diaspora, disparate elements may be united by their adoption of Afrocentric apparel. Visualizations of Afrocentric clothing are made with reference to Kemet and are therefore mental constructions that are mimetic because they draw upon the idea of an ancient African self and its accompanied gestures, which are of course an aberration, occasioned by the pathology that Fanon alluded to. Around the time of the 1960s American civil rights movement, Afrocentricism became important and sometimes central to the fashion expressions of black people living in America, the Caribbean, and Britain.

Ordinarily, Afrocentric clothing does not feature fine linen dresses, kilts, collars, or the wearing of kohl on one’s eyes; yet Afrocentric dressing does feature selected apparel motifs and long-established textiles, production, and cutting methods from the rest of Africa. Afrocentric fashion references the apparel traditions of multicultural Africa, including the traditions of both the colonizers and the colonized. The story of batik (which is Indonesian in origin) is an example of the former.

For Afrocentrists, Afrocentric dress is the norm; consequently Western dress is “ethnic” and therefore “exotic.” For that reason, Afrocentric dress has become a virtuoso expression of African diaspora culture. Political and cultural activities like black cultural nationalism have adopted Afrocentric fashion for its visual symbolism. African and black identity and black nationalism are expressed by the wearing of African and African-inspired dress such as the dashiki, Abacos (Mao-styled suit), Kanga, caftan, wraps, and Buba. All of these items are cultural products of the black diaspora and are worn exclusively or integrated into Western dress.

These fashions connote a dissonance. The combination of Afrocentric and Western styles in a single garment or outfit is a direct confrontation of Western fashion, especially if the clothing does not simultaneously promote an Afrocentric leitmotiv or theme. Within its configuration, Afrocentric dress co-opts a number of textiles. Ghanaian kente cloth, batik, mud cloth, indigo cloth, and, to a lesser extent, bark cloth are used. Interestingly,

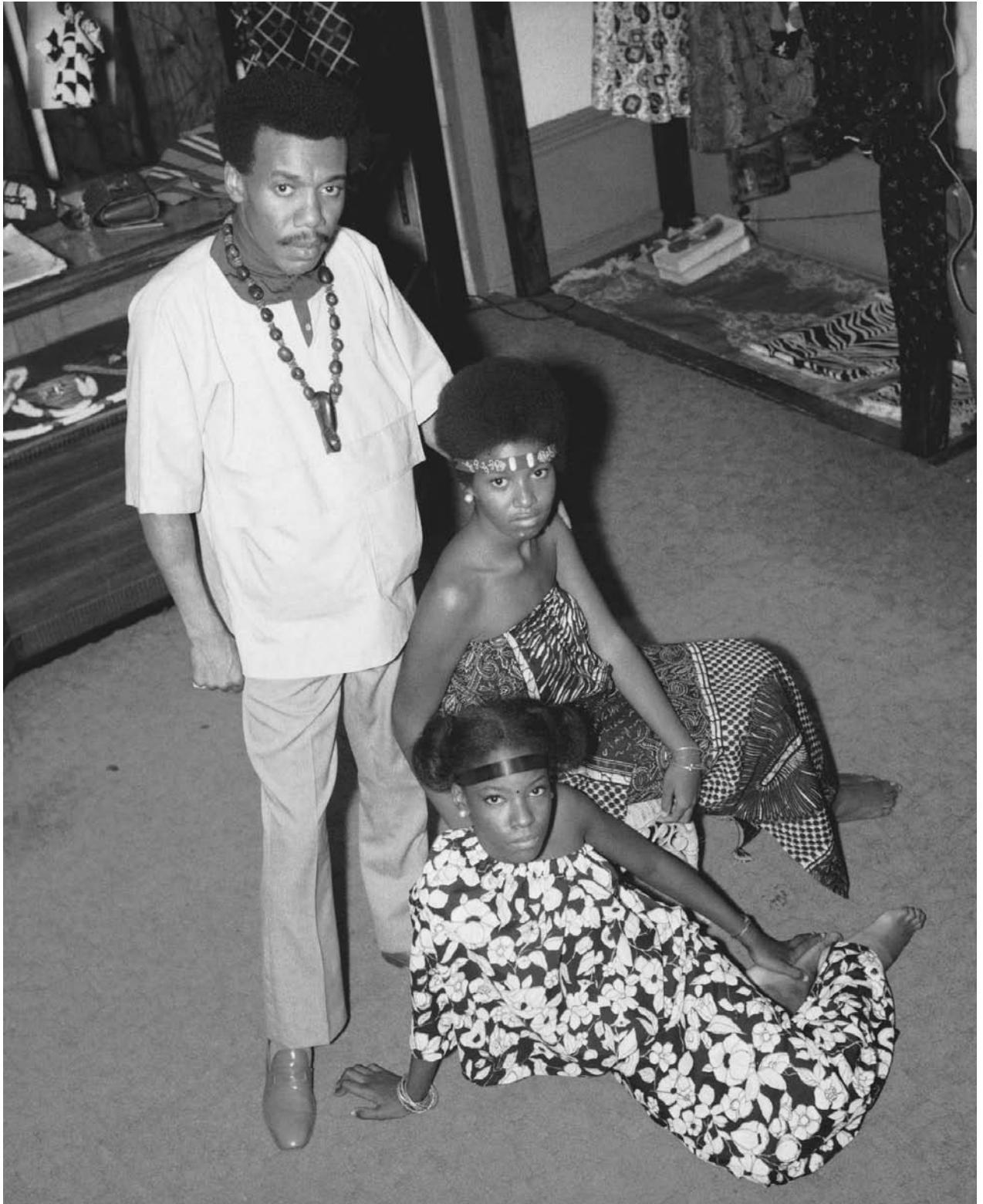

**Trio modeling Afrocentric clothing.** The women wear *bubas*, a type of floor-length West African garment, and the man wears a loose-fitting *dashiki* shirt and wooden jewelry. © BETTMANN/CORBIS. REPRODUCED BY PERMISSION.



dashikis, Abacos, Kangas, caftans, wraps, and Saki robes are all made in kente, batik, and mud cloth, but are also made in plain cottons, polyesters, and glittery novelty fabrics and tiger, leopard, and zebra prints.

Less popular are apparel items that do not assimilate well in everyday life; these are grand items such the West African Buba, which can be a voluminous floor-length robe that is often embroidered at the neckline and worn both by men and women. Various types of accessories such as skullcaps, kofis, turbans, and Egyptian- and Ghanaian-inspired jewelry are worn with other Afrocentric items or separately with Western items. Afrocentric fabrics that are made into ties, purses, graduation cowls, and pocket-handkerchiefs have special significance within the middle-class African diaspora.

### Who Has Worn Afrocentric Fashion?

The most significant expression of Afrocentricity outside of Africa existed in America during the 1960s and 1970s. The Black Panthers and other black nationalist and civil rights groups used clothing as a synthesis of protest and self-affirmation. Prototype items consisted of men's berets, knitted tams, black leather jackets, black turtle-neck sweaters, Converse sneakers, and Afrocentric items including dashikis, various versions of Afro hairstyles, and to a lesser extent Nehru jackets, caftans, and djellabas for men. Women adopted tight black turtleneck sweaters, leather trousers, dark shades, Yoruba-style head wraps, batik wrap skirts, and African inspired jewelry. For both men and women, the latter items were Afrocentric; the former were incorporated into Afrocentricity because the constituency wore them and popularized them, and they became idiomatic of black protest.

In 1962, Kwame Brathwaite and the African Jazz-Art Society and Studios in Harlem presented a fashion and cultural show that featured the Grandassa Models. The show became an annual event. The purpose was to explore the idea that "black is beautiful." It did so by using dark-skinned models with kinky hair wearing clothes that used African fabrics cut in shapes derivative of African dress. The impetus for the popularity of Afrocentric fashion in America arose from this event. The Grandassa Models explored the possibilities of kente, mud cloth, batik, tie-dye, and indigo cloths, and numerous possibilities of wrapping cloth, as opposed to cut-and-sewn apparel. Subsequently, such entertainers as Nina Simone, Aretha Franklin, the Voices of East Harlem, and Stevie Wonder on occasion wore part or full Afrocentric dress. In America, the Caribbean, and Britain, Afrocentric fashion was most popular during the 1960s and 1970s. Turbans, dashikis, large hooped earrings, and cowrie shell jewelry became the most popular Afrocentric fashion items.

Similar to the Black Panthers, Jamaican Rastafarians wear "essentialized" fashion items. However, spiritual, aesthetic, and cultural values of Rastafarianism are implied through various apparel items. The material culture

of Rastafarianism is directly linked to cultural resistance, signified by military combat pants, battle jackets, and berets. These items were introduced in the 1970s and provided Rastafarians with a sense of identity that is further supported and symbolized by dreadlocks, the red, green, and gold Ethiopian flag, and the image of the Lion of Judah, which represents strength and dread.

Jamaican Dancehall, a music-led subculture that started with picnics and tea dances in the 1950s, features a wide repertoire of fashion themes. One widely used theme is African. African dress is omnipresent in Dancehall fashion; items such as the baggy "Click Suits," worn by men in the mid-1990s, were based on the African Buba top and Sokoto pants. Women's fashions—including baggy layered clothing made in vibrant and sometimes gaudy colors; transparent, plastic, or stretchable fabrics; and decorations, such as beading, fringing, or rickrack—were shaped into discordant Western silhouettes. Dancehall fashions of the 1990s symbolized sexuality, self-determination; and freedom. Wearers rejected apparel that was comfortable and practical in favor of clothing that celebrated hedonism.

Wearers of Afrocentric dress distinguish themselves and celebrate "Africanness" within the context of the West. Adoption of Afrocentric clothing is a way of casting aside the deep psychological rift of topographical past and modern present that the psychiatrist Frantz Fanon writes of in *Black Skin, White Masks* (1967). Afrocentric dress is also present in black music cultures of the Caribbean, United States, and the United Kingdom. In the early 2000s B-boys and girls, Flyboys and girls, Dancehall Kings and Queens, Daisy Agers, Rastafarians, neo-Panthers, Funki Dreds, and Junglist all include Afrocentricity in their fashion choices. Afrocentric fashion features combinations of commonplace apparel items that represent dissonance with selected preeminent pieces from Africa's primordial past and its present.

See also **African American Dress; Batik; Boubou; Dashiki; Kente.**

### BIBLIOGRAPHY

- Diop, Cheikh Anta. *The African Origin of Civilization: Myth or Reality*. New York: Lawrence Hill and Company, 1974.
- Fanon, Frantz. *Black Skin, White Masks*. New York: Grove Press, 1967.
- Vaillant, Janet G. *Black, French, and African: A Life of Leopold Sedar Senghor*. Cambridge, Mass.: Harvard University Press, 1990.

Van Dyk Lewis

**AGBADA** *Agbada* is a four-piece male attire found among the Yoruba of southwestern Nigeria and the Republic of Benin, West Africa. It consists of a large, free-flowing outer robe (*awosoke*), an undervest (*awotele*), a pair of long trousers (*sokoto*), and a hat (*fila*). The outer robe—

from which the entire outfit derives the name *agbada*, meaning “voluminous attire”—is a big, loose-fitting, ankle-length garment. It has three sections: a rectangular centerpiece, flanked by wide sleeves. The center-piece—usually covered front and back with elaborate embroidery—has a neck hole (*orum*) and big pocket (*apo*) on the left side. The density and extent of the embroidery vary considerably, depending on how much a patron can afford. There are two types of undervest: the *buba*, a loose, round-neck shirt with elbow-length sleeves; and *dansiki*, a loose, round-neck, sleeveless smock. The Yoruba trousers, all of which have a drawstring for securing them around the waist, come in a variety of shapes and lengths. The two most popular trousers for the *agbada* are *sooro*, a close-fitting, ankle-length, and narrow-bottomed piece; and *kembe*, a loose, wide-bottomed one that reaches slightly below the knee, but not as far as the ankle. Different types of hats may be worn to complement the *agbada*; the most popular, *gobi*, is cylindrical in form, measuring between nine and ten inches long. When worn, it may be compressed and shaped forward, sideways, or backward. Literally meaning “the dog-eared one,” the *abetiaja* has a crestlike shape and derives its name from its hanging flaps that may be used to cover the ears in cold weather. Otherwise, the two flaps are turned upward in normal wear. The *labankada* is a bigger version of the *abetiaja*, and is worn in such a way as to reveal the contrasting color of the cloth used as underlay for the flaps. Some fashionable men may add an accessory to the *agbada* outfit in the form of a wraparound (*ibora*). A shoe or sandal (*bata*) may be worn to complete the outfit.

It is worth mentioning that the *agbada* is not exclusive to the Yoruba, being found in other parts of Africa as well. It is known as *mbubb* (French, *boubou*) among the Wolof of Senegambia and as *riga* among the Hausa and Fulani of the West African savannah from whom the Yoruba adopted it. The general consensus among scholars is that the attire originated in the Middle East and was introduced to Africa by the Berber and Arab merchants from the Maghreb (the Mediterranean coast) and the desert Tuaregs during the trans-Saharan trade that began in the pre-Christian era and lasted until the late nineteenth century. While the exact date of its introduction to West Africa is uncertain, reports by visiting Arab geographers indicate that the attire was very popular in the area from the eleventh century onward, most especially in the ancient kingdoms of Ghana, Mali, Songhay, Bornu, and Kanem, as well as in the Hausa states of northern Nigeria. When worn with a turban, the *riga* or *mbubb* identified an individual as an Arab, Berber, desert Tuareg, or a Muslim. Because of its costly fabrics and elaborate embroidery, the attire was once symbolic of wealth and high status. Those ornamented with Arab calligraphy were believed to attract good fortune (*baraka*). Hence, by the early nineteenth century, the attire had been adopted by many non-Muslims in sub-Saharan

Africa, most especially kings, chiefs, and elites, who not only modified it to reflect local dress aesthetics, but also replaced the turban with indigenous headgears. The bigger the robe and the more elaborate its embroidery, the higher the prestige and authority associated with it.

There are two major types of *agbada* among the Yoruba, namely the casual (*agbada iwole*) and ceremonial (*agbada amurode*). Commonly called *Sulia* or *Sapara*, the casual *agbada* is smaller, less voluminous, and often made of light, plain cotton. The *Sapara* came into being in the 1920s and is named after a Yoruba medical practitioner, Dr. Oguntola Sapara, who felt uncomfortable in the traditional *agbada*. He therefore asked his tailor not only to reduce the volume and length of his *agbada*, but also to make it from imported, lightweight cotton. The ceremonial *agbada*, on the other hand, is bigger, more ornate, and frequently fashioned from expensive and heavier materials. The largest and most elaborately embroidered is called *agbada nla* or *girike*. The most valued fabric for the ceremonial *agbada* is the traditionally woven cloth popularly called *aso ofi* (narrow-band weave) or *aso oke* (northern weave). The term *aso oke* reflects the fact that the Oyo Yoruba of the grassland to the north introduced this type of fabric to the southern Yoruba. It also hints at the close cultural interaction between the Oyo and their northern neighbors, the Nupe, Hausa, and Fulani from whom the former adopted certain dresses and musical instruments. A typical narrow-band weave is produced on a horizontal loom in a strip between four and six inches wide and several yards long. The strip is later cut into the required lengths and sewn together into broad sheets before being cut again into dress shapes and then tailored. A fabric is called *alari* when woven from wild silk fiber dyed deep red; *sanyan* when woven from brown or beige silk; and *etu* when woven from indigo-dyed cotton. In any case, a quality fabric with elaborate embroidery is expected to enhance social visibility, conveying the wearer's taste, status, and rank, among other things. Yet to the Yoruba, it is not enough to wear an expensive *agbada*—the body must display it to full advantage. For instance, an oversize *agbada* may jokingly be likened to a sail (*aso igbokun*), implying that the wearer runs the risk of being blown off-course in a windstorm. An undersize *agbada*, on the other hand, may be compared to the body-tight plumage of a gray heron (*ako*) whose long legs make the feathers seem too small for the bird's height. Tall and well-built men are said to look more attractive in a well-tailored *agbada*. Yoruba women admiringly tease such men with nicknames such as *agunlejika* (the square-shouldered one) and *agunt'asoolo* (tall enough to display a robe to full advantage). That the Yoruba place as much of a premium on the quality of material as on how well a dress fits resonates in the popular saying, *Gele o dun, bii ka mo o we, ka mo o we, ko da bi ko yeni* (It is not enough to put on a headgear, it is appreciated only when it fits well).

Since the beginning of the twentieth century, new materials such as brocade, damask, and velvet have been

used for the *agbada*. The traditional design, along with the embroidery, is being modernized. The *agbada* worn by the king of the Yoruba town of Akure, the late Oba Adesida, is made of imported European velvet and partly embroidered with glass beads. Instead of an ordinary hat, the king wears a beaded crown with a veil (*ade*) that partly conceals his face, signifying his role as a living representative of the ancestors—a role clearly reinforced by his colorful, highly ornate, and expensive *agbada*.

In spite of its voluminous appearance, the *agbada* is not as hot as it might seem to a non-Yoruba. Apart from the fact that some of the fabrics may have openwork patterns (*eya*), the looseness of an *agbada* and the frequent adjustment of its open sleeves ventilate the body. This is particularly so when the body is in motion, or during a dance, when the sleeves are manipulated to emphasize body movements.

See also **Africa, Sub-Saharan: History of Dress.**

#### BIBLIOGRAPHY

- De Negri, Eve. *Nigerian Body Adornment*. Lagos, Nigeria: Nigeria Magazine Special Publication, 1976.
- Drewal, Henry J., and John Mason. *Beads, Body and Soul: Art and Light in the Yoruba Universe*. Los Angeles: UCLA Fowler Museum of Cultural History, 1998.
- Eicher, Joanne Bubolz. *Nigerian Handcrafted Textiles*. Ile-Ife, Nigeria: University of Ife Press, 1976.
- Heathcote, David. *Art of the Hausa*. London: World of Islam Festival Publishing, 1976.
- Johnson, Samuel. *The History of the Yorubas*. Lagos, Nigeria: CMS Bookshops, 1921.
- Krieger, Colleen. "Robes of the Sokoto Caliphate." *African Arts* 21, no. 3 (May 1988): 52–57; 78–79; 85–86.
- Lawal, Babatunde. "Some Aspects of Yoruba Aesthetics." *British Journal of Aesthetics* 14, no. 3 (1974): 239–249.
- Perani, Judith. "Nupe Costume Crafts." *African Arts* 12, no. 3 (1979): 53–57.
- Prussin, Labelle. *Hatumere: Islamic Design in West Africa*. Berkeley: University of California Press, 1986.

*Babatunde Lawal*

**ALAÏA, AZZEDINE** Azzedine Alaïa was born in southern Tunisia in about 1940 to a farming family descended from Spanish Arabic stock. He was brought up by his maternal grandparents in Tunis and, at the age of fifteen, enrolled at l'École des beaux-arts de Tunis to study sculpture. However, his interest in form soon diverted him toward fashion. Alaïa's career started with a part-time job finishing hems (assisted at first by his sister, who also studied fashion). He became a dressmaker's assistant, helping to copy couture gowns by such Parisian couturiers as Christian Dior, Pierre Balmain, and Cristóbal Balenciaga for wealthy Tunisian clients; these luxurious and refined creations set a standard for excellence that Alaïa has emulated ever since.

In 1957 Alaïa moved to Paris. His first job, for Christian Dior, lasted only five days; the Algerian war had just begun and Alaïa, being Arabic, was probably not welcome. He then worked on two collections at Guy Laroche, learning the essentials of dress construction. Introduced to the cream of Parisian society by a Paris-based compatriot (Simone Zehrfuss, wife of the architect Bernard Zehrfuss), Alaïa began to attract private commissions. Between 1960 and 1965 he lived as a housekeeper and dressmaker for the comtesse Nicole de Blégiers and then established a small salon on the Left Bank, where he built up a devoted private clientele. He remained there until 1984, fashioning elegant clothing for, among others, the French actress Arlette-Leonie Bathiat, the legendary cinema star Greta Garbo, and the socialite Cécile de Rothschild, a cousin of the famous French banking family. Alaïa also worked on commissions for other designers; for example, he created the prototype for Yves Saint Laurent's Mondrian-inspired shift dress.

#### Ready-to-Wear Collections

By the 1970s, in response to the changing climate in fashion, Alaïa's focus shifted from custom-made gowns to ready-to-wear for an emerging clientele of young, discerning customers. Toward the end of the decade he designed for Thierry Mugler and produced a group of leather garments for Charles Jourdan. Rejected for being too provocative, they have been kept ever since in Alaïa's extensive archive. In 1981 he launched his first collection; already favored by the French fashion press, he soon found international success. In 1982 he showed his prêt-à-porter, or ready-to-wear, line at Bergdorf Goodman in New York, and in 1983 he opened a boutique in Beverly Hills. The French Ministry of Culture honored him with the Designer of the Year award in 1985. He has dressed many famous women, such as the model Stephanie Seymour, the entertainer and model Grace Jones, and the 1950s Dior model Bettina. Moreover, Alaïa was the first to feature the supermodel Naomi Campbell on the catwalk.

In the early 1990s Alaïa relocated his Paris showroom to a large, nineteenth-century, glass-roofed, iron-frame building on the rue de Moussy. There he lives and works, accompanied by various dogs, and his staff, regardless of status, eat lunch together every day. Partly designed by Julian Schnabel and adorned with his artwork, the building's calm, pared-down interior, glass-roofed gallery, and intense workshops resemble a shrine to fashion. Alaïa has always been a nonconformist; since 1993 he has eschewed producing a new collection every season, preferring to show his creations at his atelier when they are ready, which is often months later than announced.

#### King of Cling

Alaïa's technique was formed through traditional couture practice, but his style is essentially modern. He is best known for his svelte, clinging garments that fit like a second skin. Although he is revered in the early 2000s, the



1980s were in many ways Alaïa's time; his use of stretch Lycra, silk jersey knits, and glove leather and suede suited the sports- and body-conscious decade. The singer Tina Turner said of his work, "He gives you the very best line you can get out of your body. . . . Take any garment he has made. You can't drop the hem, you can't let it out or take it in. It's a piece of sculpture" (Howell, p. 256).

Alaïa has described himself as a *bâtitseur*, or builder, and his tailoring is exceptional. He cuts the pattern and assembles the prototype for every single dress that he creates, sculpting and draping the fabric on a live model. As he explains, "I have to try my things on a living body because the clothes I make must respect the body" (Mendes, p. 113). Although his clothes appear simple, many contain numerous discrete components, all constructed with raised, corsetry stitching and curved seaming to achieve a perfect sculptural form. Georgina Howell wrote in *Vogue* in March 1990:

He worked out dress in terms of touch. He abolished all underclothes and made one garment do the work. The technique is dazzling, for just as a woman's body is a network of surface tensions, hard here, soft there, so Azzedine Alaïa's clothes are a force field of give and resistance. (p. 258)

Utilizing fabric technology first designed for sportswear to skim the body in stretch fabric that made women's bodies look as smooth as possible, Alaïa produced a stunning variety of fashions. They included jersey sheath dresses with flesh-exposing zippers, dresses made of stretch Lycra bands, taut jackets and short skirts, stretch chenille and lace body suits, leggings, skinny jumper dresses with cutouts, and dresses with spiraling zippers. To this oeuvre he added bustiers and cinched, perforated leather belts; cowl-neck gowns; *broderie anglaise* or gold-mesh minidresses; and stiffened tulle wedding gowns. His palette favored muted colors, in particular, black, uncluttered and unadorned with jewelry.

### Alaïa's Influence

Whether applied to his haute couture, tailoring, or ready-to-wear lines, Alaïa's work is typified by precision and control; these characteristics apply even to his designs for mail-order companies, such as Les 3 Suisses and La redoute. He survived the 1990s without glossy advertising campaigns and without compromise, and in 2001 Helmut Lang paid tribute to Alaïa's work in his spring and summer 2001 collection.

Alaïa is a perfectionist and has been known to sew women into their outfits in order to get the most perfect fit. Often accompanied by his friend, confidante, and muse, the model and actress Farida Khelfa, he is of small stature and invariably dresses in a black Chinese silk jacket and trousers and black cotton slippers, declaring that he would look far too macho in a suit. Alaïa's work has been shown in retrospectives at the Bordeaux Museum of Contemporary Art (1984–1985) and the

Groninger Museum in the Netherlands (1998), and in the exhibition *Radical Fashion* at the Victoria and Albert Museum in London (2001). In 2000 Prada acquired a stake in Alaïa; the agreement contains the promise of creating a foundation in Paris for the Alaïa archive, which includes not only his own creations but also designs by many twentieth-century couturiers, such as Madeleine Vionnet and Cristóbal Balenciaga. Alaïa said, "When I see beautiful clothes I want to keep them, preserve them. . . . clothes, like architecture and art, reflect an era" (Wilcox, p. 56).

See also **Fashion Designer; Fashion Models; Jersey; Supermodels.**

### BIBLIOGRAPHY

- Alaïa, Azzedine, ed. *Alaïa*. Göttingen, Germany: Steidl, 1999.
- Baudot, François. *Alaïa*. London: Thames and Hudson, Inc., 1996.
- Howell, Georgina. "The Titan of Tight." *Vogue*, March 1990, pp. 456–459.
- Mendes, Valerie. *Black in Fashion*. London: V & A Publications, 1999.
- Wilcox, Claire, ed. *Radical Fashion*. London: V & A Publications, 2001.

Claire Wilcox

**ALBINI, WALTER** Walter Albini (1941–1983) was born Gualtiero Angleo Albini in Busto Arsizio, Lombardy, in northern Italy. In 1957 he interrupted his study of the classics, which his family had encouraged him to pursue, and enrolled in the Istituto d'Arte, Disegno e Moda in Turin, the only male student admitted to the all-girls school. A gifted student, Albini studied drawing and specialized in ink and tempera, at which he excelled. He took a degree in fashion design in 1960.

Fashion design remained an abiding interest for Albini. Even as an adolescent he worked as an artist for newspapers and magazines, to whom he sent sketches of the fashion shows held in Rome and Paris, a city for which he felt an intense and profound affinity. Paris was a fundamental step in his creative and emotional development, as evidenced by the many references to the French designers Paul Poiret and Coco Chanel in his work. In Paris, where he remained from 1961 to 1965, Albini met Chanel—a designer he admired throughout his life and to whom he dedicated his 1975 haute couture show in Rome. He was inspired by the importance Chanel gave to freeing the woman's body, to mixing and coordinating different pieces, and to accessorizing. While still in Paris he became friends with Mariucci Mandelli, who started the Krizia line and with whom he had a lifelong friendship. After Albini's return to Italy, he worked for three years (1965–1968) designing sweaters for Krizia. The designer, Karl Lagerfeld was also working for Krizia in this period. Mandelli once said of Albini, "I was never

disappointed with Walter. He never gave in to vulgarity, pettiness, or mediocrity; he was a character straight out of (F. Scott) Fitzgerald, maybe the last. He gave us a lesson in style" (Bocca, p. 138).

Albini worked as a consultant for several companies and designed for Billy Ballo, Cadette, Trell, and Montedoro. He selected fabrics and designs for Etro and created several collections for Basile. In 1967 *Vogue Italia* published a six-page spread of his work for the Krizia collection, and by 1968 he was already well known to other designers. The next year he presented his own Mister Fox line, a name that had been suggested by his friend the journalist Anna Piaggi. The collection comprised sixteen elegant suits, eight of which (all black) were called "the widows" and the other eight (all flesh-colored), "the wives." The garments were made in collaboration with the industrialist, Luciano Papini.

Albini was the first to initiate a series of innovative reforms in Italian fashion that responded to a changing market. These innovations included freeing the designer from the anonymity of the world of production and treating him as a creator, as in the world of haute couture, and recognizing the need for the fashion industry to provide styles and images and not only clothing, so that it could reach new market segments in a rapidly changing world. Albini worked closely with fabric manufacturers and enhanced the presence of the designer in industrial production.

He also helped create specialized companies in different sections of industry, so that they could collaborate to produce a collection with a recognizable brand name. These companies included well-known names like Basile for coats, skirts, and jackets; Escargots for jersey; Callaghan for knitwear, Mister Fox for evening dress; Diamant's for shirts. An agreement with FTM (Ferrante, Tositti, Monti) gave rise to a new label—"Walter Albini for," followed by the name of the manufacturer. At the Circolo del Giardino in Milan (28 April 1971), a prêt-à-porter collection was presented for the first time. The collection, made of dresses, shirts, coats, trousers, evening dress, hats, shoes, and jewelry was designed by just one designer in coordination with producers from different industries, each of them specialized in its own field of production. The collection was then sold as a whole to shops, which sold them as they were conceived. It was the system of prêt-à-porter as we currently know it. The 7 June 1971 issue of *Women's Wear Daily*, entitled "Putting It Together," reported on this epochal change in fashion.

In 1971 Albini was the first designer to abandon the Sala Bianca at Palazzo Pitti in Florence—together with Caumont, Trell, Ken Scott, Missoni, Krizia—which was still associated with the older fashion tradition, in favor of Milan. That year, 1971, is considered the official birth of prêt-à-porter. Bianca was a place strictly connected to the name of Giovanni Battista Giorgini and to the offi-

cial birth of Italian fashion with the collective catwalk shows of January 1952. Sala Bianca continued its activities until 1982, when Milan, already the center of the emerging new design prêt-à-porter, took over.

The 1973 Venice catwalk show took place among the tables of the celebrated Caffè Florian, which had been closed for the day. It was a magical moment for Albini. "It had been a long time since so much tweed, velvet, silk, and lamé, worn by these elegant women, had grazed the exquisitely decorated woodwork of the Caffè Florian in Piazza san Marco" (Vercelloni 1984, p. 90).

There are a number of constants in Walter Albini's designs and inspiration: the deco style, Poiret interpretation of liberty, Bauhaus, futurism, constructivism, the art of the 1910s to 1930s when a new feminine representation emerged especially with the work of Chanel. Albini's constants in design are jackets with half belts, flat collars, wide pants, the famous shirt jacket that was to become a classic of Italian men's clothing, sandals, two-tone shoes, Bermuda shorts, sports jackets, knit caps worn low on the forehead, and the first waterproof boots. He invented the image of the woman in pants, jacket, and shirt and reintroduced the use of print designs, both abstract and figurative. His favorite themes were the zodiac, the ballerina, the Scottish terrier, and the Madonna.

Albini is considered the inventor of the "total look," derived from his single-minded emphasis on accessories and details that became almost more important than the garment itself. It was Albini who first developed the idea of using music in place of an announcer during fashion shows. He also conceived the idea of grouping advertising pages in fashion magazines. But Albini was even more tied to the past, to the historical roots that inspired him, to the perfect elegance that is never achieved without a fanatical attention to the search for perfection in the intelligent and ironic use of older styles.

When Albini's agreement with FTM terminated in 1973, he founded Albini Srl with Papini. The new company produced and distributed the WA label, with MISTERFOX as their commercial line of clothing. In this endeavor, too, Albini was ahead of his time. His love of fashion went hand in hand with his interest in research and traveling to Asia—India, in particular, and also Tunisia, where he found inspiration for his creations. He bought apartments in his favorite cities, one on the Grand Canal in Venice, another on Piazza Borromeo in Milan, and a third in Sidi-fu-Said in Tunisia. Each of them, in its own way, expressed the aesthetics of the surrounding environment.

In 1975 Albini presented his first fall collection for men—another area in which he was a precursor of later designers. But the fashion world was not quite ready for Albini's innovations. When Albini was at the height of his success, there was not sufficient financial support in a still immature clothing and textile market. Toward the end of his career, his manufacturers could not live up to



their commitments; Paolo Rinaldi, his companion and press agent, remained his only supporter. Albini died in Milan at the age of forty-two.

Walter Albini cannot easily be categorized, because of the richness and variety of his designs, their intimacy and complexity, and the fact that the designs were ahead of their time. “A creative genius in the pure state,” wrote Isa Vercelloni, Albini “is always somewhere else, at least one step ahead of what is predictable, and a thousand miles ahead of what we anticipate” (1984, p. 235). A key figure of Italian artistic culture, Albini still evokes deep admiration. His memory lingers on in the images taken by the many photographers who worked with him: Aldo Ballo, Maria Vittoria Corradi Backhaus, Giampaolo Barbieri, and Alfa Castaldi.

See also **Chanel, Gabrielle (Coco); Fashion Designer; Fashion Shows; Italian Fashion; Ready-to-Wear.**

#### BIBLIOGRAPHY

- Bianchino, Gloria, and Arturo Quintavalle. *Moda: Dalla fiaba al design. Italia 1951–1989*. Novara, Italy: Istituto geografico De Agostini, 1989.
- Bocca, N. “La coerenza dello stile.” In *Walter Albini: Lo stile nella moda*. Edited by Paolo Rinaldi. Modena, Italy: Zanfi Editori, 1988.
- Gastel, Minnie. *50 anni di moda italiana*. Milan: Vallardi, 1995.
- Morini, E., and N. Bocca. *La moda italiana*. Volume 2: *Dall'antimoda allo stilismo*. Milan: Electa, 1987.
- Vercelloni, Isa Tutino. “Walter Albini 1968.” In *Il genio antipatico: Creatività e tecnologia della moda italiana 1951/1983*. Edited by Pia Soli. Milan: Mondadori, 1984.
- . “Albini Walter.” In *Dizionario della moda*. Edited by Guido Vergani. Milan: Baldini and Castoldi, 1999.

Simona Segre Reinach

**A-LINE DRESS** The term “A-line” is used to describe a dress, skirt, or coat with a triangular silhouette, narrow and fitted at the top and widening out from the bust or waist in a straight line to the hem. More specifically, it is understood to mean a structured garment, which stands away from the body to form the sides of the *A*. The fronts of A-line garments are often cut in one piece, with darts for fitting, and the skirts often have no waistband.

The term first entered the vocabulary of fashion via the couturier Christian Dior’s collection for Spring 1955, which he named the “A-Line.” In the 1950s, the international fashion press looked to Paris, and Dior in particular, to set the direction fashion would take each season. Dior obliged by organizing each new collection around a specific idea, and giving each a name that described or evoked that idea. In 1954 and 1955, he designed three closely related collections, based on the shapes of the letters *H*, *A*, and *Y*, which marked a move away from the strongly emphasized, nipped-in waist that



**A-line ensemble.** Introduced by designer Christian Dior in the mid-1950s, A-line garments flared outwards toward the hem and de-emphasized the waist, creating a silhouette similar in appearance to the letter “A.” © BETTMANN/CORBIS. REPRODUCED BY PERMISSION.

had been the dominant silhouette since his 1947 “Corolle Line” (or “New Look”) collection. The most influential of these was the “A-Line” collection, characterized by narrow shoulders and a smooth, trumpetlike flare toward the hem; the elongated waistline, either high under the bust or dropped toward the hips, formed the crossbar of the *A*. The signature look of this collection (the “most wanted silhouette in Paris,” according to *Vogue*, 1 March 1995, p. 95) was a fingertip-length flared jacket worn over a dress with a very full, pleated skirt; while it was clearly an A-shape, this silhouette was quite different from what was later meant by “A-line.”

Though the example set by the A-Line collection was not immediately followed, and Christian Dior explored other ideas in subsequent collections, the idea of the A-shape was a success, and the term quickly entered common usage. The A-line was one of a series of controversial mid- to late-1950s looks that de-emphasized the waist and brought an easier, more casual look to fashion; chemise and sack dresses, loose tunics, and boxy suits were shown by Dior, but also by other couturiers, most notably Balenciaga and Chanel. The most dramatic of these, in which the A-line idea was given its ultimate expression, was the Spring 1958 “Trapeze Line” introduced by Dior’s successor, Yves Saint Laurent, in his

first collection for the house of Dior. The Trapeze silhouette, in which dresses flared out dramatically from a fitted shoulder line, was considered extreme by many, but it did establish the A-line dress, with its highly structured, clean lines, as a suitable look for modern times. A more subdued version of the A-line shape was introduced in the early 1960s, and A-line dresses and skirts remained a popular style choice through the mid-1970s.

By the early 1980s, however, A-line garments, and flared shapes in general, had almost completely disappeared. The new loose silhouette was an update of the sack shape, with dresses and tunics falling loosely from an exaggerated shoulder line. Some 1960s styles received a retro revival later in the decade, but as long as the shoulders remained padded and the tops loose-fitting, straight skirts were required to balance the look. A-line skirts and dresses were not revived until the late 1990s, when the retro trend embraced the styles of the 1970s, and closely fitted garments with narrow shoulders and fitted sleeves came back into fashion. By this time, following almost twenty years of straight skirts and dresses, the term had been out of use for so long that its earlier, more specific meanings had been forgotten. It is used loosely to describe any dress wider at the hips than at the bust or waist, and a variety of flared skirt styles. With the revival of true A-line shapes in the early 2000s, however, there are signs that the terms originally used to describe them are beginning to return as well.

See also **Chemise Dress; Dior, Christian; Saint Laurent, Yves.**

#### BIBLIOGRAPHY

Keenan, Brigid. *Dior in Vogue*. London: Octopus Books, 1981. Excellent chronological and thematic guide to the Dior collections and their influence.

Musheno, Elizabeth J., ed. *The Vogue Sewing Book*. Rev. ed. New York: Vogue Patterns, 1975. Contains helpful typology, with illustrations, of 1960s–1970s garments and style terms.

*Susan Ward*

**ALPACA** The alpaca is a domesticated member of the camel family and native to the high Andes Mountains of Peru, Bolivia, Chile, and northwestern Argentina. Alpacas are small animals raised primarily for their fleece. They were domesticated over 5,000 years ago, and it is thought that humans used their fiber for 4,000 years prior to domestication. Alpaca has been considered a luxury fiber for much of this time, for example the Incan Empire reserved alpaca fiber for royalty.

Alpacas are close relatives of the llama and vicuña (see sidebar). Llamas were used as beasts of burden, whereas alpacas were primarily used for their soft, luxurious fiber. Alpacas differ from llamas in that they are smaller and lack the coarse and brittle hair of the llama.

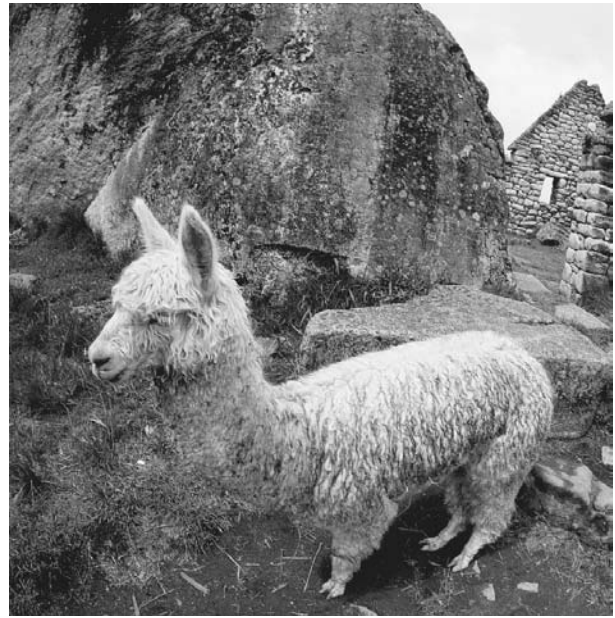

**A Peruvian alpaca.** Alpaca fleece is soft, luxurious, light weight, and free of many of the irritants found in sheep's wool. Alpacas are sheared in the spring and the fleece is spun to make yarn. © GEORGE D. LEPP/CORBIS. REPRODUCED BY PERMISSION.

Alpaca differs from sheep's wool in that it lacks the greasy lanolin coating on its fleece and wool fiber's prominent scales. Without the lanolin, the fiber hangs from the animal in glossy strands and can be processed into yarn without a complicated scouring process. In addition, people with sensitivities to wool generally find that they can wear alpaca without their skin being irritated. Its hypoallergenic nature is due to it being lanolin-free and having very fine scales on the surface of the fiber.

The fibers of the alpaca are hollow. This gives alpaca an excellent insulating ability and makes alpaca fiber products feel very light in weight.

The wool fiber is sheared from the alpaca in the spring of every year. The fiber ranges in length from eight to twelve inches, and sometimes longer. It is generally processed on the woolen spinning system to produce soft, airy yarns.

There are two types of alpacas, the *huacaya* and the *suri*. The *huacaya* alpacas have soft and crimped (wavy) fiber. The *suri* alpacas have long, pencil-like locks of fiber, which are silky and lustrous. They both produce over twenty natural colors of alpaca, including white, light fawn (a light, grayish brown), light to dark brown, gray, black, and piebald (blotched with white and black). Like sheep's wool, alpaca fiber absorbs dyes very well.

Alpaca fiber is desirable because it is fine, soft, lustrous, and elastic. In the nineteenth century, Sir Titus Salt made use of alpaca's properties to create luxury fab-



### VICUÑA

Vicuñas (vy-KOON-yuh) are the smallest member of the South American camel family. They live at an altitude of 12,000 to 16,000 feet near the snowline of the Andes Mountains. Adult vicuñas are 2½ to 3 feet (69 to 91 centimeters) high and weigh 75 to 140 pounds (34 to 64 kilograms).

Vicuña fiber's limited supply and luxurious qualities make it one of the most valuable luxury fibers. The vicuñas' wild nature made it easiest to obtain the fiber by killing the animals. In 1970, vicuñas were placed on the Endangered Species List. Over the last thirty years, the Andean countries protection efforts have allowed the vicuña population to increase. Efforts are under way to change its classification from an "endangered" to "threatened" species.

Each vicuña provides about 4 ounces (114 grams) of fine fiber and around 8 ounces (284 to 340 grams) of shorter, less choice fiber. Fine vicuña fibers measure 12 microns in diameter, which is finer than cashmere. Its color ranges from red-brown to light tan to yellow-red. The fiber's softness, luster, strength, and warmth without weight result in highly desirable fabrics. Raw vicuña fiber, which includes fine and less-choice fiber, has sold at auction for \$200 per pound.

In 2004, the only vicuña wool that can be legally traded is that which is sheared from a live vicuña at an officially authorized facility. Since the vicuña is an endangered species, those wishing to import it must carefully examine and follow the regulations governing its trade.

rics for the English market. Alpaca yarns were inserted into the weft (crosswise direction) of the fabric with yarns of cotton, silk, or wool in the warp (lengthwise direction). In the early 2000s, alpaca fiber is found in knit sweaters, hats, and scarves that are hand- or machine-made. Many handmade products are manufactured in the countries where alpaca first originated.

Alpacas have a gentle and docile disposition that has made them popular animals for hobby farms in the United States and Canada. In 2001 the Alpaca Breeders and Owners Association reported over 30,000 registered alpacas in North America. The products made from the fiber from these alpacas are being marketed through the Alpaca Fiber Cooperative of North America, Inc.

*See also* **Fibers; Wool; Yarns.**

### BIBLIOGRAPHY

"Endangered and Threatened Wildlife and Plants: Proposed Reclassification of Certain Vicuña Populations from Endangered to Threatened and a Proposed Special Rule." *Federal Register*, Proposed Rules, 64, no. 173 (September 1999): 48743-48757.

### Internet Resources

Alpaca Fiber Cooperative of North America, Inc. "About Alpaca." Available from <http://www.americasalpaca.com>.

"Species Profile for Vicuña." U.S. Fish and Wildlife Service. Available from <http://endangered.fws.gov>.

*Ann W. Braaten*

### AMERICA, CENTRAL, AND MEXICO: HISTORY OF DRESS

Cultural artifacts such as clothing and cloth also serve as signs that communicate visually in a silent language. This communication is a kind of visual literacy: becoming familiar with the language of textiles is similar to learning how to read, only it means learning how to read cloth, clothing, and how it is worn. To the untrained eye, traditional clothing worn by indigenous people of Mexico and Central America may impress and startle. It may be embroidered or handwoven in rainbow colors with geometric, floral, animal, or human images, or elaborated with commercial trims. Clothing may convey categories relating to rank, class, status, region or town, religion, or age (Schevill 1986).

### Geography

Mexico and Central America encompass cool temperate highlands and warm tropical lowlands and islands. The great northern desert is intersected by the Sierra Madre, which extends into Southern Mexico and Central America and forms the highlands and is inhabited predominantly by indigenous people. To the west is the Pacific Ocean, and the Gulf of Mexico and the Caribbean Sea lie to the east. Volcanoes, dense tropical jungles, long stretches of beaches, deep canyons, and fertile mountain valleys share a cultural history dating for over 3,000 years, from 1500 B.C.E. to C.E. 1519. Great ceremonial centers flourished in remote geographical areas connected by trade networks. Contrasting environmental conditions and a wide range of raw materials have influenced the evolution of clothing and have fostered the variety of styles in use in the early twenty-first century.

### Persistence and Innovation

Why have typical clothing and cloth production persisted in parts of Mexico, Guatemala, and Panama, and not in Honduras, El Salvador, Nicaragua, and Costa Rica? Some factors to consider are: the geographic isolation of towns and regions; the continuance of markets and the fiesta cycle; the symbolization of town ideals in clothing; and the differentiation of civil-religious hierarchies through clothing. Closer to the urban areas, men's and





## TIMELINE

**Mexico**

- 1519 Arrival of Cortés
- 1521 Fall of Aztec Empire
- 1528–1535 Mexico rules by Royal Audiencia, called New Spain
- 1535–1810 Colonial Period
- 1810–1821 Mexican Revolution
- 1821 Independence from Spain

**Guatemala**

- 1523 Invasion by Alvarado
- 1524 Conquest of various Maya groups
- 1523–1821 Colonial Period
- 1821 Independence from Spain

children's Western-style dress has replaced typical clothing. The desire to dress like the rest of the world, encouraged by television and tourism, has created a market for jeans, T-shirts, and sport shoes. In the past, outsiders stereotyped indigenous communities as inherently conservative and resistant to change. Two conflicting principles, however, affect textile production: the artistic, creative impulse to innovate and the conservative constraint, which is tradition-bound. Artists of the loom and needle respond to new materials, techniques, and patrons—who are tourists, entrepreneurs, or advisers involved in marketing textiles abroad. The fashion impulse is part of innovation, and new clothing trends among certain age groups may be observed in the way a garment is worn, the colors and designs, and layout (Schevill 1997, pp. 129–143).

**Dress Form Survivals**

Present in contemporary indigenous dress are what some call pre-Columbian dress form survivals, such as the woman's *huipil*, or upper body garment, and the small shoulder *quechquémitl*, or shawl, as well as the man's *calzones*, or pants, and a sleeveless jacket, *xicolli*. Hispanic dress form survivals also exist. Women's blouses, head veils, gathered skirts, men's tailored pants and jackets, sombreros, and, of course, shoes for both men and women are only a few examples.

**Western and Traditional Combinations**

Urban and rural males still leave their homes seasonally to work on large coffee and cotton *fincas* (plantations) and wear Western-style clothing in order to avoid racial discrimination against them. But at fiesta time, people re-

turn to their communities and wear typical clothing and participate in traditional activities called *costumbre*. Women and men may use several elements of traditional clothing along with Western-style dress. The rebozo or *perraje*, a shawl, is a good example (Logan et al. 1994). Both *ladinas* and *mestizas* (persons of mixed Indian, African, and/or Spanish ancestry who do not belong to one of the indigenous cultural groups) include rebozos in their dress ensemble. Another fashion phenomenon relates to adaptations of other than Spanish foreign dress styles. The Tarahumaras (Raramuris) of Chichuahua's Sierra Madre, under the influence of the missionaries, adopted aspects of non-Indian culture, while retaining traditional arts, such as weaving. Their clothing is hand-sewn of commercial patterned cloth with full skirts and blouses, some with peplums. Women cover their heads with cloths in a bandanna style, while men continue to wear turbans and loincloths of white commercial cotton (Green 2003). The male Mam speakers of Todos Santos Cuchumatán, Huehuetenango (Guatemala), adapted black woolen tailored overpants, a style worn by the French Navy who visited Guatemala in the mid-nineteenth century and wear them over their own handwoven long pants. In southeastern Central America, off the northern coast of Panama, are the San Blas islands inhabited by the indigenous Kunas. The women's *molas*, or blouses, are made of commercial multicolored cotton. Two similar intricately hand-stitched appliquéd panels adorn a woman's blouse front and back. Some of the imagery reflects outside influences as seen in billboards, advertisements, and television.

**The Art of the Weaver**

Before the Conquest, a woman was expected to weave for herself and her family and to produce ceremonial clothes for use in temples and as offerings. A fine weaver had status in the community, as she does as late as the twenty-first century. Clothing and cloth also produced extra income when made for sale. Children learned by imitation, watching their mothers spin, prepare yarn, warp the loom, and weave. By the age of twelve, whether or not they like it, weaving must be taken seriously. Before that, it is like a game, but by the marrying age of sixteen, a woman must be an accomplished weaver.

**Looms**

The backstrap loom has been in use in Mexico and Central America since 1500 B.C.E. A Classic Maya ceramic figurine recovered from Jaina Island off the eastern coast of Mexico is of a weaver at her backstrap loom. This loom is sometimes called the hip-loom, or stick-loom (*telar de palitos*), and although both male and female indigenous weavers produce cloth on this simple apparatus, it is largely associated with women. When the cloth, often selvaged on both ends, is removed from the loom, only the sticks and ropes remain. Also in use are staked, horizontal looms and floor or treadle looms introduced by



**Three Central American men in hats and shirts.** Contemporary Central American dress draws from both native traditions and new styles, fusing the Old and New Worlds together. J.J. FOX/NYC. REPRODUCED BY PERMISSION.

the Spanish after the Conquest. Weaving of this kind was taught to indigenous males, who soon learned how to produce yardage, a requisite for the cut-and-sew tailored fashions of the Spanish. In the early 2000s, Zapotec male weavers in Teotitlán del Valle, Oaxaca (Mexico), weave fine woolen rugs and blankets on treadle looms, and double-ikat cotton cloth for skirts is woven in Salcajá, Quezaltenango (Guatemala), by Maya men. Both male and female weavers in the Totonicapán (Guatemala) area use a unique loom that combines features of the back-strap and treadle loom to create headbands. In addition, both draw and jacquard loom weavers produce yardage of great complexity.

#### Materials

Cotton has been the most important fiber for weavers since pre-Columbian times. The two varieties are a long-staple white cotton and a short-staple, tawny colored cotton known as *ixcaq*, *ixcaco*, *coyuche*, or *cuyuscate*. Agave, yucca, and other vegetal fibers, as well as dyed rabbit hair and feathers are still in use. The feathered wedding dress continues to be worn by the Tzotzil women of Zinacantán, Chiapas (Mexico). After the Spanish introduced sheep, wool was readily adopted by native weavers for its warmth, its sturdy and thick texture, and its ability to take dyes. For ornamentation, colored imported silk, pearl

cotton, assorted embroidery cottons, and synthetic yarn are employed.

#### Dyes

Because of the paucity of archaeological textile remains, it is not known with certainty what natural dyes were employed in pre-Columbian textiles. The painted codices, ceramics, and other visual material give some clues (Anawalt 1981). Indigo (blue), brazil wood, and cochineal (red), *palo de tinta* (black), cinnabar (red-brown), and *purpura patula* (lavender) may have been in use. The 1856 invention of chemical dyes in Europe expanded the color palette throughout the world. These dyes were quickly adopted and used along with some of the natural dyes. By early 2000s, natural dyes were reintroduced to many Mexican and Guatemalan weavers and embroiderers. Rainbow coloring is a predictable and enjoyable aspect of twenty-first-century clothing.

#### Techniques

Warp-predominant cloth with supplementary weft brocading is one of the most frequently represented combinations. It is a technique for decorating the cloth while still on the loom. There are three types of brocading: single-faced with a pattern recognizable on one side; two-faced with the decorative yarn floating on the reverse side





**Oaxacan folk dancer.** In Mexico and Central America, elaborate costumes consisting of embroidered cotton blouses and long ruffled skirts are frequently worn for special occasions and festivals. © BOB KRIST/CORBIS. REPRODUCED BY PERMISSION.

between pattern areas forming an inverse of the design; and double-faced brocading that creates a nearly identical pattern on both sides. Other techniques include, first and foremost, embroidery, then knitting, beading, crocheting, and more. As with the acceptance of chemical dyes, the advent of the sewing machine and availability of commercial cloth and trims have replaced in many areas what was formerly accomplished by hand.

### Iconography

Iconography is varied. Geometric shapes, plants, animals, and human images are woven in a representational, stylized, or abstract fashion. The precise meaning of these designs to the weavers may never be known, as they are a part of the collective consciousness or mythical history and not actually discussed. Clothing is memory.

### Garment Repertoire

There is a great variety of indigenous clothing worn throughout this vast geographic area. The individual garment styles, however, are a shared tradition.

**Women.** The upper garment or *huipil*, a Nahuatl word, is the most important component of a woman's clothing. Nahuatl was the language of the Aztecs and is still spoken in many Mexican communities. The *huipil* can be short or long, of two or three backstrap or floor-loomed pieces joined together, sometimes with a decorative stitching, and neck and arm openings. Designs are woven in as part of the weaving process, embroidered or commercial fabrics, such as ribbons or rickrack, can be added. Particularly fine, handwoven; or embroidered *huipiles* are worn by the Zapotecs of Oaxaca, Mexico, and by the Mayas of Chiapas, Yucatán, and Guatemala. Skirts are either wrap-around and held in place by wide or narrow handwoven belts or gathered to a waistband. The fabric can be either solid colored, commonly dark blue, or patterned floor-loomed cotton. The tie-dyed or ikat (*jaspe*) multicolored skirts of the K'iche' and Cakchiquel Mayas (in Guatemala) are outstanding. Multipurpose backstrap-loomed cloths are essential for covering the head and to wrap food or objects. Aprons are cut-and-sew garments, a Hispanic dress form survival that serves decorative as well as functional purposes. The adornment of the head and hair is especially important. The Yalalags of Oaxaca use heavy yarn headdresses, while many Mayas wear tapestry woven headbands with elaborate tassels. The women of the northern Sierra of Puebla (Mexico) have perfected the art of the embroidered blouse with the sewing machine (Anawalt and Berdan 1994). In the early 2000s, young Maya women of Chiapas embroidered motifs on their blouses of commercial cloth, whereas in the past, the decoration was the result of supplementary weft brocading. The *quechquemil*, or capelike shoulder garment, is still worn by older Nahuatl and Otomi women in Puebla, while large shoulder cloths are in general use throughout the area. Sandals and jewelry complete the woman's dress ensemble.

**Men.** Tailored pants, loose-fitting and held up with a wide belt, are of white manta or commercial cotton, as well as handwoven multicolored cloth. As with women's *huipiles*, the shirts may be loom-decorated. Shoulder bags are knitted or crocheted in cotton and wool. Often, men create their own bags. Others are made for sale, a popular tourist item. In colder areas, men need overgarments of black or multicolored wool and shoulder or hip blankets. Handwoven head cloths may be worn under the sombrero in a pirate fashion. Hatbands often adorn the sombreros. Tailored cotton or wool jackets, along with the sleeveless style, are worn over the shirt. Men also wear sandals or shoes.

**Children.** Children dress as their parents do when possible, in smaller versions of typical clothing.

### Occasions for Special Clothing

Each region has distinctive styles of dress for special occasions; these styles are derived from family or area traditions and sometimes pay tribute to historical happenings.



Map of Central America and Mexico. Similar clothing and cloth production can be found in parts of Mexico, Guatemala, and Panama, but are less apparent elsewhere in the region. THE GALE GROUP.

**Cofradías.** There are religious organizations associated with the Catholic Church for men and women called *cofradías*. Participants take care of the church, the statues of saints, and sponsor religious ceremonies often in their own homes. The women wear ceremonial *huipiles*, and men demonstrate their importance in the community with special head cloths, jackets, and hats.

**Contests, Festivals, Fiestas.** The indigenous population wears special clothing on festive occasions. For example, in El Salvador for fiestas, white ruffled cotton blouses with red embroidery and long white ruffled skirts replace Western-style dress (Valasquez 2003). In many regions of Guatemala and Mexico, there are beauty contests in which the indigenous and ladina contestants wear the most beautiful traditional clothing available. Fiestas celebrating the saints' days are the occasion for costumed dances that are often of Spanish origin, and special rented dance costumes are required on these occasions. The

*quinceañera* or fifteenth birthday party for a young woman is another occasion for special clothing.

Contemporary Mexican and Central American dress owes its richness and variety to the fusion of clothing styles and textiles from the Old and New Worlds.

See also **Embroidery; Handwoven Textiles.**

**BIBLIOGRAPHY**

Anawalt, Patricia Rieff. *Indian Clothing before Cortes*. Norman: University of Oklahoma Press, 1981. A pioneering research study that looks at a variety of visual materials to ascertain pre-Columbian indigenous dress.

Anawalt, Patricia Rieff, and Frances F. Berdan. "Mexican Textiles." In *National Geographic Society Research and Exploration* 10, no. 3(1994): 342–353. An exploration of acculturation, how changes are integrated into contemporary indigenous clothing.

Arriola de Geng, Olga. *Los tejedores in Guatemala y la influencia española en el traje indígena*. Guatemala City: Litografias

- Modernas, S.A., 1991. A discussion of the Spanish influence on Guatemalan indigenous dress.
- Asturias de Barrios, Linda, and Dina Fernández García, eds. *La indumentaria y el tejido mayas a través del tiempo*. Guatemala City: Museo Ixchel del Traje Indígena, 1992. Available in Spanish and also in an English translation, scholars discuss the evolution of Maya dress and weaving from a historical perspective.
- Asturias de Barrios, Linda, ed. *Nuestra nacionalidad tiene su propia identidad*. Guatemala City: Prensa Libre, occidente corporación, 1995. An overview in Spanish of language and clothing diversity among the Mayas of Guatemala.
- Cordry, Donald, and Dorothy Cordry. *Mexican Indian Costumes*. Austin and London: University of Texas Press, 1968. The first complete study of Mexican Indian dress.
- Green, Judith Strapp. Personal communication, 8 May, 15 May 2003.
- Johnson, Grace, and Douglas Sharon. *Cloth and Curing: Continuity and Change in Oaxaca*. San Diego, Calif.: San Diego Museum of Man, San Diego Museum Papers No. 32, 1994. Johnson focuses on native clothing of Oaxaca and presents the Oaxacan textile collection at the San Diego Museum of Man. Schevill discusses the communicative nature of indigenous and mestizo clothing and cloth in Mexico and Guatemala.
- Logan, Irene, Ruth Lechuga, Teresa Castello Yturbide, Irmgard Weitlaner Johnson, and Chloë Sayer. *Rebozos de la colección Robert Everts*. Mexico D.F.: Museo Franz Mayer-Artes de Mexico, 1994. In Spanish, scholars trace the history of the rebozo from the perspective of the Franz Mayer collection.
- Morris, Walter F., Jr., and Jeffrey Jay Foxx. *Living Maya*. New York: Harry N. Abrams, 1987. A fine description of Maya life in Chiapas, Mexico, a landmark publication.
- O'Neale, Lila M. *Textiles of Highland Guatemala*. Publication 567. Washington, D.C.: Carnegie Institution of Washington, 1945. The first complete study of Maya textiles of Guatemala. An outstanding piece of scholarship with great attention to detail.
- Osborne, Lilly de Jongh. *Indian Crafts of Guatemala and El Salvador*. Norman: University of Oklahoma Press, 1965. The author combines folklore with her firsthand pioneering experiences in the field in the early part of the twentieth century.
- Salvador, Mari Lyn. *The Art of Being Kuna*. Los Angeles: UCLA Fowler Museum of Cultural History, 1997. An exhibition catalog that fully documents all aspects of Kuna life.
- Sayer, Chloë. *Costumes of Mexico*. Austin: University of Texas Press, 1985. An update of the Cordrys' book, including sections on pre-Conquest, post-Conquest, and twentieth-century textiles.
- Schevill, Margot Blum. *Costume as Communication: Ethnographic Costumes and Textiles from Middle America and the Central Andes of South America*. Bristol, R.I.: Haffenreffer Museum of Anthropology, Brown University, 1986. A focus on the textiles from Mexico, Guatemala, Peru, and Bolivia in the Haffenreffer Museum collection and a theoretical discussion on the theme of costume as communication.
- . *Maya Textiles of Guatemala: The Gustavus A. Eisen Collection, 1902*. Austin: University of Texas Press, 1993. The Eisen collection is the earliest and best documented Maya textile collection extant. Included is an essay by Christopher H. Lutz that looks at late-nineteenth-century Guatemalan Mayas, and an essay comparing the Eisen collection with an overview of Maya textiles of the 1980s.
- Schevill, Margot Blum, Janet Catherine Berlo, and Edward B. Dwyer, eds. *Textile Traditions of Mesoamerica and the Andes: An Anthology*. Austin: University of Texas Press, 1996. Twenty-one scholars write about specific features of Mesoamerican and Andean contemporary clothing, weaving and dyeing technology, and marketing practices.
- Schevill, Margot Blum, ed., and Jeffrey Jay Foxx, photographer. *The Maya Textile Tradition*. New York: Harry N. Abrams, 1997. Four scholars, James D. Nations, Linda Asturias de Barrios, Margot Blum Schevill, and Robert S. Carlsen, write about Maya life in Mexico, Belize, and Guatemala from different perspectives.
- Valesquez, Myra. Personal communication, 14 May 2003.

Margot Blum Schevill

## AMERICA, NORTH: HISTORY OF INDIGENOUS PEOPLES' DRESS

The native peoples of North America are diverse in culture, language, and ecological adaptations to varied environments. This variation is expressed in their attire. The only major constant in their clothing prior to European contact was the use of the skins of animals—most notably the tanned skins of the variety of large North American mammals—buffalo or bison, antelope, mountain sheep, caribou, and others. Owing to its wide geographic distribution, deer was the most prevalent. Smaller animals such as mink, beaver, and rabbit were also used but mainly for decorative effects.

Native peoples in certain regional areas did create textile clothing technologies that mainly utilized fibers harvested from gathered plant products and sometimes used spun thread made from hair from both domesticated and killed or captured wild animals. From Alaska down through the gathering cultures of the Plateau, Great Basin, and California tribes as far to the southwest as the border of Mexico, woven products were worn literally from head to toe. Hats, capes, blouses, dresses, and even footwear were constructed of plant material. In the north, this practice reflected the deleterious effects of the constant dampness of the coastal temperate rain forest climate upon skin products, and in the south it was largely due to the scarcity or rarity of large animals for skins. For example, as a means to maximize available resources, several Great Basin tribes had developed a system of weaving strips of the skins of small animals (like rabbits) into blankets or shawls.

Before contact, the main decorative additions for clothing were paints and the quills of the porcupine and the shafts of stripped bird feathers. Entire feathers from a variety of birds were used as well, with the feathers from large raptors, especially the eagle, signifying prestige and sacred power among many tribes. Dyes and paints were





**Hopi Kachina dolls.** *Kachinas* were gods or spirits, and Hopi dancers often emulated them in their performances. Hopi mythology maintained that Kachina costumes gave magical powers to the wearer, and the masks in particular were considered sacred.  
© GEOFFREY CLEMENTS/CORBIS. REPRODUCED BY PERMISSION.

used to color both the additive elements and the main bodies of the clothes themselves. These coloring agents were derived from plant and mineral sources, and in some areas very sophisticated systems for obtaining different colors from the local flora were in place. These products, as well as paints derived from regional mineral outcroppings, became important trade items.

Bone and shell ornaments were used as jewelry—bracelets, earrings, combs, and hair ornaments—and to a lesser extent as clothing ornaments. Extensive precontact trade routes existed for the distribution of these items, with the coveted shimmering abalone shells and the tapering conical dentalia shells that resembled miniature elephant tusks being traded from California and the more northerly Pacific Coast to the Great Plains and beyond to the Great Lakes region. Similarly, shells found in the Gulf of Mexico and ornaments cut from them were traded up river trade routes to areas in the Northern Plains, Midwest, and Great Lakes regions. A wide network also existed for the disbursement of the beads cut from Atlantic shells, later known to early European settlers as “wampum.”

The only evidences of metallurgy north of Mexico occurred among the so-called Mound Builders of the Mississippi and Ohio valleys, where copper mined largely in the islands of Lake Superior and traded south to be turned into jewelry and other ornaments existed. On the

Pacific Northwest Coast, exploitation of similar “native copper” deposits, allowed the nearly pure copper product to be exploited as jewelry, knives, and other implements. The unique metal shieldlike objects created were a pure demonstration of wealth, which represented prestige and status among the “Potlatch People” of the Northwest Coast.

The abundance of resources in the Pacific coastal region led to the extensive use of various vegetation sources for clothing; in the north from Alaska to Northern California people relied upon evergreen root and inner-bark fibers, together with sedges, grasses, and ferns. As the rain forest climate gives way to marshy environments and grassy savannas in the south, the material from grasses and other smaller plants predominates. Nevertheless, this general area created some of the finest basketry products ever made by humanity, and a great array of basket-woven products was used as apparel. Large rain hats, caps, various forms of capes and wraps, dresses, kilts, leggings, and even shoes met the varying needs of the people of the western coast.

Peoples of the arid Southwest and Great Basin areas also wove clothing, but to a lesser degree, incorporating more skin products. Some sedentary tribes raised cotton that had previously been domesticated in Mesoamerica and had been traded north together with chilies, corn, and squashes as part of an agricultural diffusion. The



**Native American traditional dress.** Plains Indian clothing was made from hides sewn together with sinew and decorated with quills, fringe, animal teeth, beads, and sometimes even the human hair of enemies. © CORBIS. REPRODUCED BY PERMISSION.

Hopi, for example, produced cotton mantas or women's dresses and sashes and kilts for men. Interestingly, the men wove their own apparel items in this culture.

In the Southwest in general, men tended to wear a belt and breechclout combination, while women wore either a skirt or kilt or a dress that covered the entire torso, depending upon the tribe. More warmth for the winter months was furnished by a robe of skin tanned with the hair on, of locally obtained deer, antelope, sheep, or of trade-obtained bison. Woven rabbit-skin robes were also used. Footwear appropriate to resist a rough, rocky environment and the often-thorned plants of the desert climate assumed increased importance.

In the far north, the Arctic culture area, the Inuit (formerly called Eskimo) often utilized skins processed especially with the fur retained in such a way as to combat the frigid weather. Fitted fur garments had hoods, which were bordered with specific species of fur to minimize the formation of frost around the edge due to the condensation of moisture from exhaled breath in extreme weather. Other areas of the clothing were specifically engineered as well, with some species' skins being used for specific traits in different areas of the garment. Seal was

used for water resistance, caribou for insulative ability. Seal-skin-soled mukluks or boots with formed soles were stuffed with dried grasses or mosses to provide insulation and protect the feet. The different species' skins were used in decorative fashion as well, with different tailoring demarcating various culture groups and gender identification. In addition, coastal groups created waterproof clothing of finely stitched seal intestine that enabled sea-hunters to venture out on frigid Arctic waters, allowing them to fasten themselves into their one-man kayaks in a leak-proof manner, when the intrusion of frigid seawater might have meant death, both for the kayaker and for those he was providing for.

Referencing the next cultural area south in the interior of the continent, the Athapaskan and Northern Algonquin also designed their clothing to stave off the hazards of the northern winter. Ironically, hazards of the possibility of thawing ground occasionally posed more danger than cold itself and thus changed the clothing design needs as opposed to those of their neighbors to the north. Additional decoration possibilities were afforded by the existence of porcupine and moose in the arboreal forest, allowing the use of quills and moose-hair as overlay and embroidery elements.

Indians of the Eastern Woodlands also decorated their clothing with quill and hair, both in embroidery and appliqué. Even inland tribes could obtain trade beads and shaped objects made by the coastal tribes from the coverings of the abundant shellfish. Deer, being the most common large animal, provided the most common skins utilized for clothing. Breechclouts, deer-skin leggings worn with each end tucked into a belt, were the norm in male attire, with women generally wearing full dresses. Moccasins in the wooded areas tended to be soft-soled, of tanned deer, moose, or caribou hide, often smoked over a smoldering fire to aid in resisting moisture prior to being cut up for the shoe's construction. Deer-hide robes aided in warmth during the cooler months. Some tribes in the area did develop a textile culture using fibers from gathered plants such as the stinging nettle; however, it was largely limited to smaller objects such as pouches, bags, and sashes.

By contrast, the tribes of the Plains had virtually no textile cultural history. In addition, the environment of the Plains area necessitated a change in the footwear technology, with most tribes favoring a two-part moccasin, with a tanned-skin vamp or upper attached to a thicker rawhide sole. As in the Southwest, this was a response to the more barren ground surface and thorned plants.

With the majority of the buffalo or bison in North America residing in this area, they assumed a central position in the cultures of the Plains tribes. This importance is reflected in clothing as well, with buffalo hide becoming a major resource. In the northern tribes especially, robes of buffalo hide tanned with the hair on were highly prized as winter attire, and often highly decorated.



In order to counter the monolithic image of the Native American, one must consider, in the early 2000s, the estimated 565 viable native groups in their proper cultural contexts to truly comprehend their rich cultural diversity, linguistic variation, and clothing and design of attire.

The long utilized Culture Area concept still has pertinence in postcolonial life. Within these coalescing areas, indigenous nations were grouped, mainly along the lines of material culture items—as among the Iroquois in the Northeast where longhouses sheltered several families together based upon matrilineal clan affiliation. There, a mixed hunting and agricultural economy was fostered by matrilineal residence and inheritance through the female and allowed a focus on seasonal ceremonies such as the midwinter and harvest festivals. Ceremonial-plaited corn-husk and carved wood masks were used in these and other rituals, often in the context of healing. Stranded belts of cut-shell beads rose above mere decoration, often being created to commemorate specific events. These wampum belts served as historic record-keeping devices. Quite a number of existing belts document treaties between native and European groups, for example.

One can select any area and explicate the clothing and adornment of the groups interacting with the environmental opportunity. The Northwest Coast consisted of various peoples speaking unrelated languages, but largely sharing a vibrant cultural lifestyle based upon the possibility for economic surplus afforded by the rich maritime environment. The most dazzling and elegant designs were undoubtedly those of the Haida from the Queen Charlotte Islands off the coast of present-day British Columbia in Canada. Their totemic art was embodied in monumental totem poles and decorated house villages, masks for ceremonial use, and the beautification of virtually every object type in the culture, whether utilitarian or decorative. This urge to beautify transferred to clothing as well, with masterful painting incorporating the same curvilinear stylized totemic themes on the woven hats and mats made from cedar bark and on skin robes and tunics as well. Chilkat blankets woven of mountain-goat wool and cedar bark were important prestige items owned by powerful individuals.

All aboriginal people of North America have undergone coerced culture change by the colonizers. Although native beliefs, culture, and languages have been legally suppressed they have adapted and changed to new lifestyles. Many wear traditional styles adapted to new materials. In attire, they evidence modern styles in new fashions.

See also **America, Central, and Mexico: History of Dress; Beads; Fur; Leather and Suede.**

#### BIBLIOGRAPHY

Coe, Ralph T. *Sacred Circles: Two Thousand Years of American Indian Art*. London: Arts Council of Great Britain, 1972.

Howard, James H. "The Native American Image in Western Europe." *American Indian Quarterly* 4, no. 1 (1978).

*Beatrice Medicine*

**AMERICA, SOUTH: HISTORY OF DRESS** The vast South American continent is a study in geographic extremes, including the Amazon Basin, the world's largest tropical rain forest; the Andes, the second-highest mountain range in the world; and the coastal deserts of Peru and northern Chile, which are among the driest areas in the world. The ecology of these regions (and such areas as the hot, humid Atlantic coast and cold, wet Patagonia) naturally influenced the dress of the aboriginal South Americans. Dress includes clothing, footwear, hairstyles and headdresses, jewelry, and other bodily adornment (for example, piercing, tattooing, and painting).

#### Amazon Basin and the Coasts

Europeans landing on the coast of what is now Brazil in the early sixteenth century encountered such groups as the Tupinambás, who wore feathered headdresses, and early drawings of natives wearing feathers became shorthand for Native Americans. Feathered or porcupine quill



**Men in a traditional Tarabuco dance.** The Tarabucan dancers show off their Incan inspired tunics, worn over wide-legged cropped pants. The draped hats cover up long hair worn in a braid, an ethnic marker. Typical open-toed sandals are worn on the feet. © LYNN A. MEISCH. REPRODUCED BY PERMISSION.



**Indigenous women in Saraguro, Ecuador.** These Ecuadorian women display traditional, yet contemporary clothing that includes wide-brimmed woven hats with markings indicating ethnicity and pinned *anakus*, or wrap-around skirts and *llikllas*, or mantles. Decorative earrings and necklaces adorn them.  
© LYNN A. MEISCH. REPRODUCED BY PERMISSION.

headdresses are still worn by most Amazonian groups for daily or fiesta use. Clothing is often minimal, no more than a penis string for males and a *cache-sexe* (G-string) for females, along with body painting or tattoos, and/or earplugs or earrings, bead, fiber, animal bone or tooth necklaces, bandoleers, armbands, leg bands, and bracelets, nose and lip and hair ornaments—an infinite variety of ornamentation—and, among Kayapó and Botocudo males of Brazil, *ternbeiteras*, large circular wooden discs inserted in the lower lip.

Such groups as the Colombian and Ecuadorian Cofáns, Ecuadorian Záparos, and Ecuadorian and Peruvian Shuars and Achuars once wore bark-cloth tunics, wrap skirts or (for women) dresses tied over one shoulder. Cofán males now wear knee-length tunics of commercial cotton cloth.

Among such groups in the western Amazon as the Cashinahuas (Dwyer, 1975) and Shipibos in Peru, and the Kamsás in Colombia loom-woven cotton clothes are worn, usually long tunics (often called *kushma*) for men, and tubular skirts for women. Both male and female Ashaninkas (Campas), and Matsigenkas (Machiguengas) wear tunics, however.

Males among the Shuars and Achuars of Peru and Ecuador wear a woven cotton wrap skirt, while the women wear a body wrap that is tied over one shoulder. The male wrap is sometimes tied with a woven belt with dangling wefts of human hair (Bianchi et al. 1982). Contacted tribes in Amazonia may choose to wear traditional dress at times and Euro-American dress when visiting towns or if they have been Christianized.

Such groups as the now culturally extinct Onas of Tierra del Fuego, the cold, southern tip of South America near Antarctica, had no weaving, but wore fur robes, hats, and moccasins.

### The Andean Countries

The countries that once constituted the Inca Empire (much of Ecuador, Peru, Bolivia, Chile, and part of northern Argentina) are significant for several reasons. The first is that the Pacific coastal deserts have resulted in the preservation of organic material including mummy bundles with cadavers completely dressed. Other archaeological artifacts, such as realistic ceramics portraying dressed humans, combined with the Spanish conquistadores' and other historical accounts allow us to reconstruct the dress of ancient peoples. It is possible to generalize about the myriad local and historical highland and coastal dress styles, which can be referred to overall as Andean. First, the main fibers, dyes, and many technical features of later dress were in use by the Common Era. Fibers, handspun and handwoven on simple stick or frame looms, included New World cotton and camelid (llama, alpaca, vicuña, and wanaku). Myriad dyes were used to great effect, including Relbunium and cochineal (red to purple), indigo (blue to black), and a number of plants that gave yellow. Garments for the wealthy or high ranking were often adorned with embroidery, feathers, beads, and gold or silver discs. Second, pre-Hispanic garments were variations of the square or rectangle, and they were woven to size using virtually every technique known to modern Euro-American weavers. Jewelry varied by sex, age, and rank.

Third, textiles were four selvage, meaning all four edges were finished before the piece came off the loom. It is rare to find a cut pre-Hispanic Andean garment; tailoring came with the Spanish. Fourth, cloth was highly valued and exchanged or sacrificed at major life-cycle events and religious rituals. Dress carried heavy symbolic weight and indicated age, gender, marital status, social, political, religious, economic rank, and ethnicity.

### The Peruvian Coast

By the time of the Paracas culture (c. 600–175 B.C.E.) on the south coast of Peru, male ritual attire consisted of garments that were typical of the coast until the Spanish Conquest in 1532: headband or turban, waist-length tunic (sometimes with short, attached sleeves) or tabard, breechcloth or kiltlike wrap skirt, mantle, and sometimes sandals, and a small bag, usually used to hold coca leaves. Paracas dress was consistent in terms of size, shape, and



patterning, but varied in terms of decoration. Many Paracas garments, for example, were elaborately embroidered and many garments had added fringes, tabs, or edgings (Paul 1990).

Coastal male tunics and tabards had vertical warps and neck slits, while women's tunics were worn with the warp horizontal, with stitches at the shoulders and a horizontal neck opening (Rowe and Cohen 2002, p. 114). Women also wore a mantle. Male garments from the Chimú culture (c. C.E. 850–1532) of the north coast were sometimes woven in matched sets with identical weave structures and motifs on the tunic, breechcloth, and turban (Rowe 1984, p. 28).

For all the coastal cultures, jewelry differed by gender and rank and could include neckpieces, pectorals, bracelets, crowns, nose rings, and earplugs of copper, silver, gold, Spondylus shell, turquoise, feathers, and combinations of these materials, including the magnificent jewelry excavated from the royal tombs of Sipán of the Moche culture (c. C.E. 100–700).

### Inca Dress

Before the Spanish arrived, the Incas, spreading from their center in Cuzco, Peru, between c. 1300 and 1532, reigned over a vast empire. Mandating that conquered groups maintain their traditional clothing, headdress, and hair-style allowed the Incas to identify and control them.

Highland dress differed from that of the coast. Garments were generally woven of camelid hair because of the cold. Inca garments had a distinctive embroidered edging combining cross-knit loop stitch and overcasting, with striped edge bindings on finer textiles (called *qumpi*, often double-faced tapestry) and solid bindings on plainer ones (*awasqa*) (Rowe 1995–1996, p. 6). Cloth was important, even sacred, to the Incas, who burned fine clothing as sacrifices to the sun (Murra 1989 [1962]).

Inca women wore an ankle-length square or rectangular body wrap called an *aksu* in the southern part of the empire and *anaku* in the north. It was wrapped under the arms, then pulled up and pinned over each shoulder with a *tupu*, a stickpin made of wood, bone, copper, or—for higher status women—silver or gold. The *tupus* were connected with a cord with dangling Spondylus shell pendants. A *chumpia*, or wide belt with woven pattern, held the *aksu* shut at the waist.

Next came a *lliklla*, a mantle, held shut with another stickpin (*t'ipki*; later also called *tupu*), and an *istalla*, a small bag for coca leaves. Some females wore headbands known by *wincha*, their Spanish name, and some upper-class women wore *ñañaqas*, a type of head cloth (Rowe 1995–1996).

Male garments included the *unku*, a sacklike, sleeveless, knee-length tunic, a *yakolla*, a mantle, a *wara* (breechcloth), *ch'uspa* (coca leaf bag), and a *llautu* (headwrap). Inca noblemen wore large gold *paku*, earplugs that dis-



**Peruvian couple in native dress.** The man wears a cotton tunic, or *kushma*, and a traditional *chullo* hat. The woman wears a short jacket and a *pollera* skirt. © JEREMY HORNER/CORBIS. REPRODUCED BY PERMISSION.

tended their lower earlobes, inspiring the Spanish to call them *orejones* (big ears). Both sexes wore *usuta*, hide or plant-fiber sandals (Rowe 1995–1996).

The Aymara-speaking chiefdoms of the Peruvian and Bolivian altiplano deserve mention, as their region was known for extensive camelid herds and fine textiles (Adelson and Tracht 1983). Some pre-Hispanic-style garments are still worn by both Quechuas and Aymaras including belts, mantles, tunics, *ch'uspas*, and *aksus*, but for Aymara females on the altiplano, the emblematic gathered skirt, tailored blouse, shawl, and bowler hat are more recent.

### The Spanish Conquest

The Spanish introduced new tools for cloth production (treadle looms, carders, spinning wheels), new fibers (sheep's wool and silk), and new fashions. Soon after the conquest, upper-class male natives were wearing combinations of Inca and Spanish clothes: an Inca *unku* with Spanish knee breeches, stockings, shoes, and hat (Guzman Poma). The Spanish first insisted that native people

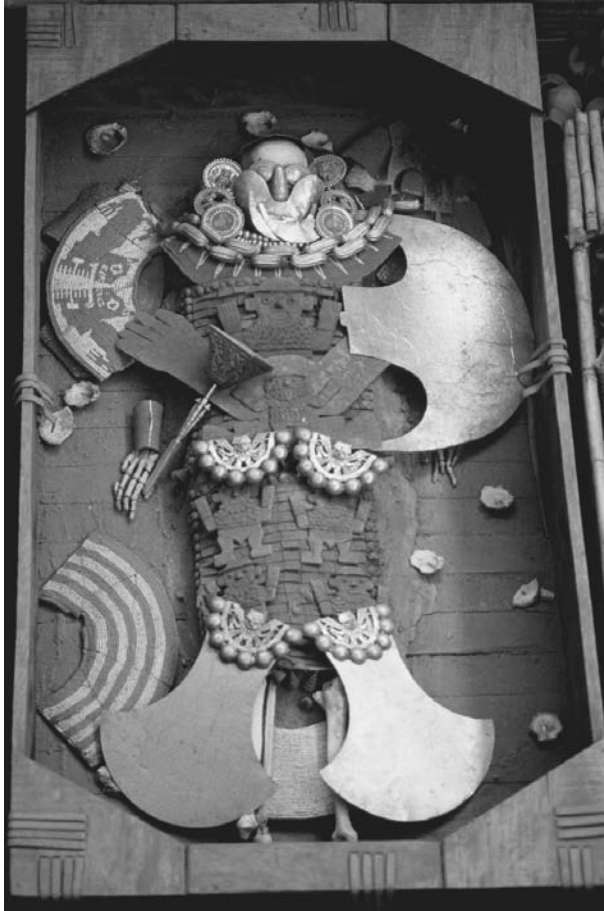

**Warrior tomb in Sipán, Peru.** For coastal cultures in Peru, jewelry was an important indicator of rank, as indicated by the gold, silver, and copper ornamentation found in this lord's tomb. © KEVIN SCHAFER/CORBIS. REPRODUCED BY PERMISSION.

wear their own dress, but after the great indigenous rebellions of the 1780s, the government of Peru prohibited the wearing of the headband, tunic, mantle, and other insignia of the Incas including jewelry engraved with the image of the Inca, or sun. Fine Inca *qumpi unku*, however, continued to be made and worn well into the colonial period (Pillsbury 2002).

Although poncho-like garments were worn before the Spanish conquest, most males wore tunics sewn up the sides. The first reference to the open-sided poncho by that name came from a 1629 description of the Mapuches (Araucanians) of Chile (Montell 1929, p. 239).

### Contemporary Andean Indigenous Clothing

Traditional Andean dress in the early twenty-first century is a mixture of pre-Hispanic and Spanish colonial styles. Dress still indicates ethnicity, and in Peru use of the *chullu* (knitted hat with earflaps) by males and *montera* (Spanish flat-brimmed hat) by females denotes indigenous identity,

with variations in the hats indicating the wearer's community. In Bolivia and Ecuador, a variety of hats indicate ethnicity and among three Ecuadorian groups (the Saraguros, Cañars, and Otavalos), and one Bolivian (the Tarabucos), one ethnic marker for males is long hair worn in a braid. The Tarabucos are also known for their unique helmet-like hat (Meisch 1986).

In several communities—for example Q'ero in Peru (Rowe and Cohen 2002), the Chipayas in Bolivia, and the Saraguros in Ecuador (Meisch 1980–1981)—males still wear versions of the Inca tunic, while the females of Otavalo, Ecuador, wear dress that is the closest in form to Inca women's dress worn anywhere in the Andes (Meisch 1987, p. 118). Throughout northern Ecuador, indigenous females of many ethnic groups still wear the *anaku*, now a wrap skirt, handwoven belt, *liklla*, sometimes a *tupu*, and distinctive hat, while males wear ponchos and felt fedoras.

In the Cuzco, Peru, region, males wear the *chullu*, the poncho, and sometimes handwoven wool pants, or Euro-American style dress, while women are more conservative and wear short jackets and sometimes vests over manufactured blouses and sweaters, and *pollera* with *likllas*, skirts with handwoven belts held shut with a *tupu*, or safety pin. In many communities, women still pride themselves on their ability to weave fine cloth using pre-Hispanic technology.

In the Ausangate region south Cuzco, such small differences in the women's dress as the length of their *pollera* and the presence of fringe on their *monteras* indicates residence (Heckman 2003, pp. 83–84).

In the Corporaque region (southern Peru), the women's dress (vests, hats, gathered skirts), while quite European in form except for their carrying cloths, is elaborately machine-embroidered in small workshops (Femenias 1980, p. 1). Although the technology is European, the importance of dress as an ethnic marker is Andean. Throughout the Bolivian, Peruvian, and Ecuadorian Andes, many indigenous people wear *usuta*, sandals made from truck tires, but in northern Ecuador, *alpargatas*, handmade cotton sandals, are worn.

Although Colombia has a small indigenous population, groups in two major highland regions maintain distinctive dress styles. The Kogis (Cágabas) and Incas of the Sierra Nevada de Santa Marta on the Atlantic coast wear long, cotton belted tunics over tight pants, and a small, round hat, cotton and pointed for the former, flat-topped fiber or cotton for the latter. Men also carry a *mochilas*, a cotton bag for their coca leaves and lime gourd. Women wear a garment that resembles the *aksu*, which is wrapped around the body, tied over one shoulder, and fastened at the waist with a belt.

After the Spanish conquest, the Páezes of southwestern Colombia developed a unique dress, abandoning simple cotton wraps. The most distinctive features of male dress are a short, wool, poncho-like garment, and a wool



wrap skirt. Throughout the Andes, children usually wear a wrap skirt until they are toilet trained; then they wear traditional dress like the adults. Native people continue to use indigenous dress to define themselves as ethnic communities, and to combine pre-Hispanic and European technologies in the manufacture of their clothing.

See also **Cache-Sexe; Homespun; Turban.**

#### BIBLIOGRAPHY

- Adelson, Laurie, and Arthur Tracht. *Aymara Weavings: Ceremonial Textiles of Colonial and 19th Century Bolivia*. Washington, D.C.: Smithsonian Institution, 1983.
- Bianchi César et al. *Artesanías y Técnicas Shuar*. Quito: Ediciones Mundo Shuar, 1982.
- Dwyer, Jane Powell, ed. *The Cashinabua of Eastern Peru*. Providence, R.I.: The Haffenreffer Museum of Anthropology, Brown University, 1975.
- Femenias, Blenda, with Mary Guaman. *El Primer nueva corónica y buen gobierno*, 3 vols. From the original *El Primer corónica y buen gobierno* by Felipe Poma de Ayala (1615). Jaime L. Urioste, trans., John Murra and Rolena Adorno, eds. Mexico City: Siglo Veintiuno, 1980.
- Heckman, Andrea. *Woven Stories: Andean Textiles and Rituals*. Albuquerque: University of New Mexico Press, 2003.
- Meisch, Lynn. "Costume and Weaving in Saraguro, Ecuador." *The Textile Museum Journal* 19/20 (1980–1981): 55–64.
- . *Otavalo: Weaving, Costume and the Market*. Quito: Libri Mundi, 1987.
- . "Weaving Styles in Tarabuco, Bolivia." In *The Junius B. Bird Conference on Andean Textiles*. Edited by Ann Pollard Rowe, 243–274. Washington, D.C.: The Textile Museum, 1986.
- Montell, Gösta. *Dress and Ornament in Ancient Peru: Archaeological and Historical Studies*. Göteborg, Sweden: Elanders Boktryckeri Aktiebolag, 1929.
- Murra, John. "Cloth and Its Function in the Inca State." In *Cloth and Human Experience*, edited by Annette B. Weiner and J. Schneider, 275–302. Washington, D.C., and London: Smithsonian Institution Press 1989 [1962].
- Paul, Anne. *Paracas Ritual Attire: Symbols of Authority in Ancient Peru*. Norman and London: University of Oklahoma Press, 1990.
- Pillsbury, Joanne. "Inka Unku: Strategy and Design in Colonial Peru." *The Cleveland Museum of Art. Cleveland Studies in the History of Art* 7(2002): 68–103.
- Rowe, Ann Pollard. *Costumes and Featherwork of the Lords of Chimor: Textiles from Peru's North Coast*. Washington, D.C.: The Textile Museum, 1984.
- . "Inca Weaving and Costume." *The Textile Museum Journal* 34/35 (1995–1996): 4–53.
- Rowe, Ann Pollard, and John Cohen. *Hidden Threads of Peru: Q'ero Textiles*. London and Washington, D.C.: Merrell Publishers and The Textile Museum, 2002.
- Vanstan, Ina. *Textiles from Beneath the Temple of Pachacamac, Peru*. Philadelphia: The University Museum, University of Pennsylvania, 1967.

Lynn A. Meisch

#### AMERICAN INDIAN DRESS: See *America, North: History of Indigenous Peoples' Dress*

**AMIES, HARDY** The British couturier Hardy Amies is best known as Queen Elizabeth II's longest-serving dressmaker. Supported by a highly skilled team in the workrooms at Savile Row, Amies dressed the queen and a small clientele of aristocratic and wealthy women for half a century. His men's wear and international licensee business had a lower profile but were crucial to the financial viability of the company. The licensee business benefited from Amies's position as dressmaker to the queen and from his staff's expertise, but its success ensured the survival of the couture house.

#### Early Life

Edwin Hardy Amies was born in London on 17 July 1909. Although he had some knowledge of dressmaking through his mother's work as a saleswoman for Miss Gray, Ltd., a London court dressmaker, it was not his chosen career. He wanted to be a journalist and on the advice of the editor of the *Daily Express* went to work in Europe to learn French and German. Back in Britain in 1931 he joined W. and T. Avery, selling industrial weighing machines and hoping to be posted to Germany, but dressmaking



**Woman modeling Hardy Amies evening gown.** Prior to 1958, Amies concentrated on producing women's garments with a particularly feminine feel, such as this satin-bodiced dress comprised of many layers of tulle. © HULTON-DEUTCH COLLECTION/CORBIS. REPRODUCED BY PERMISSION.

was clearly his destiny. A chance letter describing a dress worn by Miss Gray led to the offer of a job as designer at Lachasse, a sportswear shop owned by Miss Gray's husband, Fred Shingleton. In late 1933, Amies was invited by Mr. and Mrs. Shingleton (Miss Gray) to join their party at a dance given in aid of the Middlesex Hospital. At Christmas 1933, Amies wrote a letter to Mlle. Louise Probet-Piolat (Aunt Louie), a friend of his mother, describing the dress worn by Mrs. Shingleton at the dance. Aunt Louie in turn wrote to Mrs. Shingleton, reporting "how vivid she found my description." Mrs. Shingleton threw the letter across the table to her husband and said, "You ought to get that boy into the business in Digby Morton's place" (Amies 1954, pp. 52–53). Undeterred by his complete ignorance of practical dressmaking, Amies boldly grabbed the opportunity.

### Lachasse and the War

Lachasse was set up in 1928 as an offshoot of Fred Shingleton's company Gray and Paulette, Ltd. The firm specialized in custom-made daywear designed for members of the British upper classes, who divided their time between London and the country. When Amies joined in 1934 he replaced the Irish designer Digby Morton, whom he credited with transforming the classic country tweed suit "into an intricately cut and carefully designed garment that was so fashionable that it could be worn with confidence at the Ritz" (Amies 1954, p. 54). Following Morton, Amies concentrated on producing stylish, feminine, tailored clothes. The year 1937 was a turning point. The April edition of British *Vogue* featured a Lachasse suit, and Amies made his first sales to U.S. buyers, in London for King George VI's coronation. *Vogue* praised Amies's facility with pattern and color but noted the comparatively static silhouette of his suits, which now incorporated the slightly low waist that became characteristic of his cut. This slowly evolving line was, in fact, exactly what Amies's customers wanted. They were looking for clothes that were in tune with fashion but that would blend with their existing wardrobe, that were smart but not ostentatious, and that were well cut, immaculately fitted, and hard wearing. Amies catered to this particularly English approach to dressing throughout his career. His customers at Lachasse included the society hostess Mrs. Ernest Guinness and the actress Virginia Cherrill.

By 1939 sales at Lachasse had doubled but Amies's appeals to design in his own name were rebuffed. Restless and frustrated, he saw World War II as an escape. He joined the Intelligence Corps, transferring in 1941 to the Belgian section of the Special Operations Executive, where he rose to the rank of lieutenant colonel. Amies designed throughout the war, contributing to government-backed export collections and, after resigning from Lachasse, selling through the London house of Worth. He was a founding member of the Incorporated Society of London Fashion Designers and served as the society's chairman from 1959 to 1960.



"I understand and admire the Englishwoman's attitude to dress . . . just as our great country houses always look lived in and not [like] museums, so do our ladies refuse to look like fashion plates" (Amies 1954, p. 239).

### Savile Row

After demobilization, Amies set up his own house in November 1945 at 14 Savile Row, in the heart of London's tailoring district. Staff from Lachasse, Worth, and Miss Gray joined him, bringing their clients and skills and enabling Amies to establish a reputation for all-around excellence. Although nearly forty, he was considered young in couture terms. Amies played on this, promoting himself and his house as vigorous, youthful, and progressive. In 1950 he was among the first London couturiers to set up a boutique line aimed at export buyers, selected provincial retail buyers, and the general public. Within two years the new business was half the size of the couture business.

In 1950 Amies received his first order from the future Queen Elizabeth II. In 1955 he successfully applied for the coveted royal warrant, which he held until his death. Norman Hartnell was still the queen's premier dressmaker but Amies's position at the top of his profession was secure. Designing for the queen gave him international standing, attracted prestigious clients, and guaranteed his own personal acceptability in the highest echelons of society. He later designed for Princess Michael of Kent and Diana, Princess of Wales.

### Men's Wear

Amies entered the men's wear market in 1959, when he designed a range of silk ties for Michelson's. During the 1950s the preference of young adult men for more informal, body-conscious clothes and the popularity of American and Italian styles persuaded British manufacturers to reformulate their image and product. Hepworths, a middle-market multiple tailoring group, approached Amies. His first collection for Hepworths in 1961 was designed "to make the customer feel younger and richer than they were, and more attractive" (Amies 1984, p. 68). His designs were never cutting edge but formulated to attract a broad customer base. By 1964 the annual sales of his men's wear was about £15 million, compared with £0.75 million for women's wear. His collaboration with Hepworths led to a string of licensee agreements selling men's wear and some women's wear across the globe from the United States and Canada to Australia, New Zealand, Japan, Taiwan, and Korea. As

Amies dedicated more time to the licensee business, the women's wear design was taken over by his codirector, Ken Fleetwood (d. 1996). Amies sold Hardy Amies, Ltd., to Debenhams in 1973 to develop a ready-to-wear business but bought the company back in 1980.

Hardy Amies was appointed a Commander of the Victorian Order (CVO) in 1977 and honored with a knighthood in 1989. He was elected a Royal Designer for Industry in 1964. He received the *Harper's Bazaar* Award in 1962, the *Sunday Times* Special Award in 1965, and the British Fashion Council Hall of Fame award in 1989. He sold Hardy Amies, Ltd., to the Luxury Brands Group in 2001. Amies died on 5 March 2003.

See also **Diana, Princess of Wales; Haute Couture; Savile Row; Travel Clothing; Tweed.**

#### BIBLIOGRAPHY

- Amies, Hardy. *Just So Far*. London: Collins, 1954. Detailed account of the first ten years of the house of Hardy Amies, and considers London fashion in relation to Paris.
- . *Still Here: An Autobiography*. London: Weidenfeld and Nicolson, 1984. Covers Amies's involvement in menswear and the development of his licensee business and his work for Queen Elizabeth II.
- . *The Englishman's Suit: A Personal View of Its History, Its Place in the World Today, Its Future, and the Accessories Which Support It*. London: Quartet, 1994. Describes the evolution of the suit and Amies's taste in menswear.
- Cohn, Nik. *Today There Are No Gentlemen: The Changes in Englishmen's Clothes since the War*. London: Weidenfeld and Nicolson, 1971.
- Ehrman, Edwina. "The Spirit of English Style: Hardy Amies, Royal Dressmaker and International Businessman." In *The Englishness of English Dress*. Edited by Christopher Breward, Becky Conekin, and Caroline Cox. Oxford: Berg, 2002. Considers how Englishness informed Amies's style and how he used his association with Englishness as a marketing tool.

Edwina Ehrman

**ANCIENT WORLD: HISTORY OF DRESS** Evidence about dress becomes plentiful only after humans began to live together in greater numbers in discrete localities with well-defined social organizations, with refinements in art and culture, and with a written language. This happened first in the ancient world in Mesopotamia (home of the Sumerians, Babylonians, and Assyrians) and in Egypt. Later other parts of the Mediterranean region were home to the Minoans (on the island of Crete), the Greeks, the Etruscans, and the Romans (on the Italian peninsula).

The sociocultural phenomenon called "fashion," that is, styles being widely adopted for a limited period of time, was not part of dress in the ancient world. Specific styles differed from one culture to another. Within a cul-

ture some changes took place over time, but those changes usually occurred slowly, over hundreds of years. In these civilizations tradition, not novelty, was the norm.

Certain common forms, structure, and elements appear in the dress of the different civilizations of the ancient world. Costume historians differentiate between draped and tailored dress. Draped clothing is made from lengths of fabric that are wrapped around the body and require little or no sewing. Tailored costume is cut into shaped pieces and sewn together. Draped costume utilizes lengths of woven textiles and predominates in warm climates where a loose fit is more comfortable. Tailored costume is thought to have originated around the time when animal skins were used. Being smaller in size than woven textiles, skins had to be sewn together. Tailored garments, cut to fit the body more closely, are more common in cold climates where the closer fit keeps the wearer warm. With a few exceptions, ancient world garments of the Mediterranean region were draped.

#### Strengths and Weaknesses of Evidence about Dress

Most of the evidence about costume of the ancient world comes from depictions of people in the art of the time. Often this evidence is fragmentary and difficult to decipher because researchers may not know enough about the context from which items come or about the conventions to which artists had to conform.

The geography and climate of a particular civilization and its religious practices may enhance or detract from the quantity and quality of evidence. Fortunately, the dry desert climate of ancient Egypt coupled with the religious beliefs that caused Egyptians to bury many different items in tombs have yielded actual examples of textiles and some garments and accessories.

Written records from these ancient civilizations may also contribute to what is known about dress. Such records are often of limited usefulness because they use terminology that is unclear today. They may, however, shed light on cultural norms or attitudes and values individuals hold about aspects of dress such as its ability to show status or reveal personal idiosyncrasies.

#### Common Types of Garments

Although they were used in unique ways, certain basic garment types appeared in a number of the ancient civilizations. In describing these garments, which had different names in different locales, the modern term that most closely approximates the garment will be used here. Although local practices varied, both men and women often wore the same garment types. These were skirts of various lengths; shawls, or lengths of woven fabric of different sizes and shapes that could be draped or wrapped around the body; and tunics, T-shaped garments similar to a loose-fitting modern T-shirt, that were made of woven fabric in varying lengths. E. J. W. Barber (1994) suggests that the Latin word *tunica* derives from the Middle



Eastern word for linen and she believes that the tunic originated as a linen undergarment worn to protect the skin against the harsh, itchy feel of wool. Later tunics were also used as outerwear and were made from fabrics of any available fibers.

The primary undergarment was a loincloth. In one form or another this garment seems to have been worn in most ancient world cultures. It appears not only on men, but also is sometimes depicted as worn by women. It generally wrapped much like a baby's diaper, and if climate permitted workers often used it as their sole outdoor garment.

In most of the ancient world, the most common foot covering was the sandal. Occasionally closed shoes and protective boots are depicted on horsemen. A shoe with an upward curve of the toe appears in many ancient world cultures. This style seems to make its first appearance in Mesopotamia around 2600 B.C.E. and it is thought that it probably originated in mountainous regions where it provided more protection from the cold than sandals. Its depiction on kings indicates that it was associated with royalty in Mesopotamia. It probably came to be a mark of status elsewhere, as well (Born). Similar styles show up among the Minoans and Etruscans.

### Mesopotamian Dress

The Sumerians, as the earliest settlers in the land around the Tigris and Euphrates Rivers in what is now modern Iraq, established the first cities in the region. Active from about 3500 B.C.E. to 2500 B.C.E., they were supplanted as the dominant culture by the Babylonians (2500 B.C.E. to 1000 B.C.E.) who in turn gave way to the Assyrians (1000 B.C.E. to 600 B.C.E.).

One of the chief products of Mesopotamia, wool, was used not only domestically but was also exported. Although flax was available, it was clearly less important than wool. The importance of sheep to clothing and the economy is reflected in representations of dress. Sumerian devotional or votive figures often depict men or women wearing skirts that appear to be made from sheepskin with the fleece still attached. When the length of material was sufficient, it was thrown up and over the left shoulder and the right shoulder was left bare.

Other figures seem to be wearing fabrics with tufts of wool attached, which were made to simulate sheepskin. The Greek word *kaunakes* has been applied to both sheepskin and woven garments of this type.

Additional evidence of the importance of wool fabric comes from archaeology. An excavation of the tomb of a queen from Ur (c. 2600 B.C.E.) included fragments of bright red wool fabric thought to be from the queen's garments.

**Evidence about dress.** Evidence for costume in this region comes from depictions of humans on engraved seals, devotional, or votive statuettes of worshipers, a few wall

paintings, and statues and relief carvings of military and political leaders. Representations of women are few, and the writings from legal and other documents confirm the impression that women's roles were somewhat restricted.

**Major costume forms.** In addition to the aforementioned *kaunakes* garment, early Sumerian art also depicts cloaks (capelike coverings). Costumes of later periods appear to have grown more complex, with shawls covering the upper body. Skirts, loincloths, and tunics also appear. A draped garment, probably made from a square of fabric 118 inches wide and 56 inches long (Houston 2002), appears on noble and mythical male figures from Sumer and Babylonia. Because the garment is represented as smooth, without folds or drapery, most scholars believe that this unlikely perfection was an artistic convention, not a realistic view of clothing. With this garment men wore a close-fitting head covering with a small brim or padded roll.

Women's dress of this period covered the entire upper body. The most likely forms were a skirt worn with a cape that had an opening for the head or a tunic. Other wrapped and draped styles have also been suggested.

Transitions from Babylonian to Assyrian rule are not marked by clear changes in style. In time, the Assyrians came to prefer tunics to the skirts and cape styles that were more common in earlier periods. The length of tunics varied with the gender, status, and occupation of the wearer. Women's tunics were full-length, as were those of kings and highly placed courtiers. Common people and soldiers wore short tunics.

Fabrics ornamented with complex designs appeared in Assyria. Scholars are uncertain whether the designs on royal costumes are embroidered or woven. Elaborate shawls were wrapped over tunics, and the overall effect was complex and multilayered. Priests selected the most favorable colors and garments for the ruler to wear on any given day.

Hairstyles and headdress are important elements of dress and often convey status, occupation, or relate to other aspects of culture. Sumerian men are depicted both clean-shaven and bearded. Sometimes they are bald. In hot climates shaving the head may be a health measure and done for comfort. Both men and women are also shown with long, curly hair, which is probably an ethnic characteristic. Assyrian men are bearded and have such elaborately arranged curls that curling irons may have been used. In art women's hair is shown as either ornately curled or dressed simply at about shoulder length.

The status of women apparently changed over time. From laws it is clear that Sumerian and Babylonian women had more legal protections than did Assyrian women. Law codes make reference to veiling and it appears that in Sumerian and Babylonian periods, free married women wore veils, while slaves and concubines were permitted to wear veils only when accompanied by the



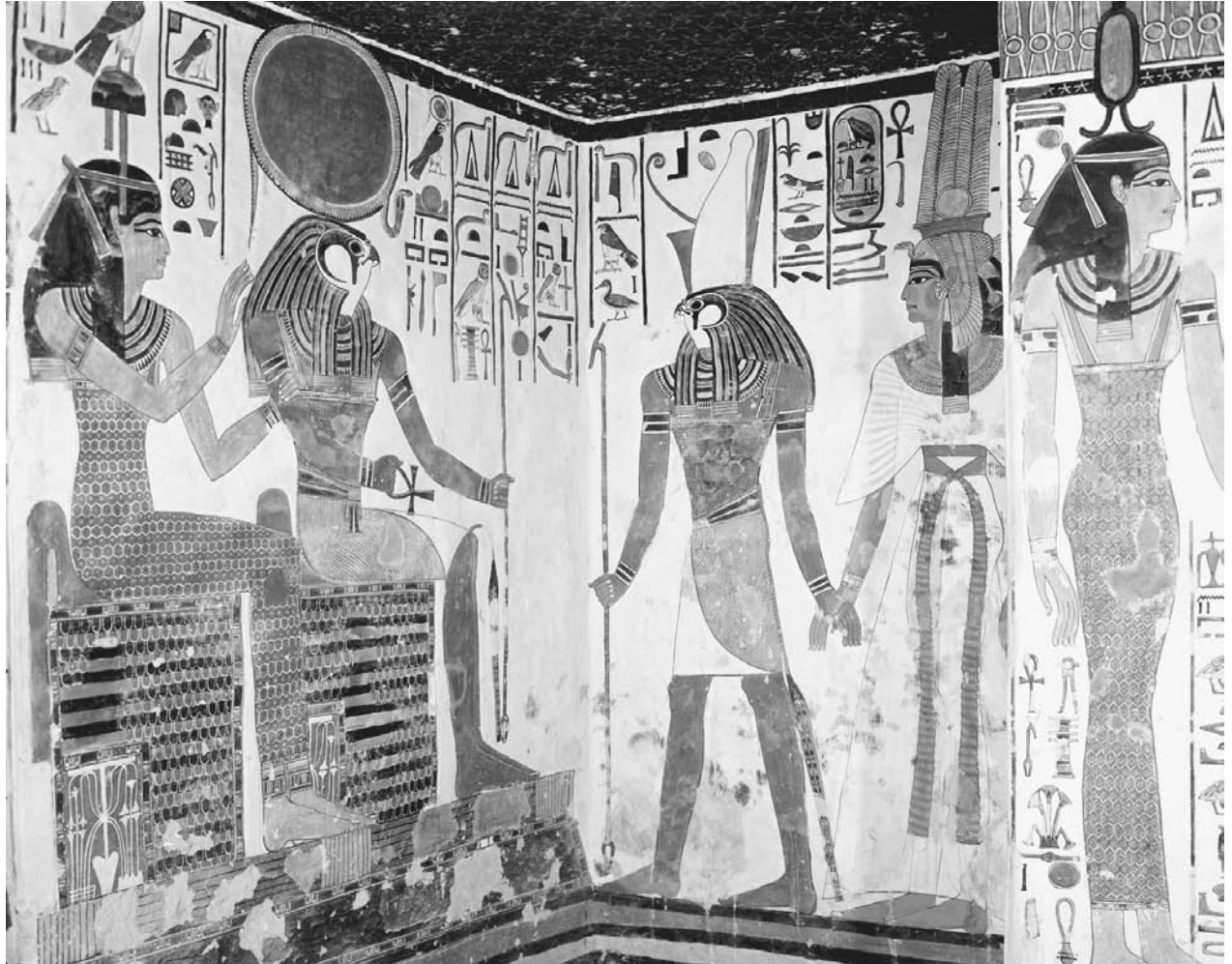

**Nefertari's tomb, Valley of the Queens.** Artistic representations such as in this mural painting, created circa 1290–1224 B.C.E., provide historians with much information on the clothing of the period. This tomb relief shows three different dress styles: a sheath dress, a pleated gown, and a man's skirt (*schenti*). © ARCHIVO ICONOGRAFICO, S.A./CORBIS. REPRODUCED BY PERMISSION.

principal wife. Specific practices as to how and when the veil was worn are not entirely clear; however, it is evident that traditions surrounding the wearing of veils by women have deep roots in the Middle East.

### **Egyptian Dress**

The civilization of Ancient Egypt came into being in North Africa in the lands along the Nile River when two kingdoms united during a so-called Early Dynastic Period (c. 3200–2620 B.C.E.). Historians divide the history of Egypt into three major periods: Old Kingdom (c. 2620–2260 B.C.E.), the Middle Kingdom (c. 2134–1786 B.C.E.), and the New Kingdom (c. 1575–1087 B.C.E.). Throughout this entire period Egyptian dress changed very little.

The structure of Egyptian society also seems to have changed little throughout its history. The pharaoh, a hereditary king, ruled the country. The next level of so-

ciety, deputies and priests, served the king, and an official class administered the royal court and governed other areas of the country. A host of lower level officials, scribes, and artisans provided needed services, along with servants and laborers, and, at the bottom, were slaves who were foreign captives.

The hot and dry climate of Egypt made elaborate clothing unnecessary. However, due to the hierarchical structure of society, clothing served an important function in the display of status. Furthermore, religious beliefs led to some uses of clothing to provide mystical protection.

**Sources of evidence about dress.** It is religious beliefs that have provided much of the evidence for dress of this period. Egyptians believed that by placing real objects, models of real objects, and paintings of daily activities in the tomb with the dead, the deceased would be provided

with the necessities for a comfortable afterlife. Depictions and actual items of clothing and accessories were among the materials included. The hot, dry climate preserved these objects. Works of art from temples and surviving inscriptions and documents are additional sources of information.

**Textile availability and production.** Linen fiber, obtained from the stems of flax plants, was the primary textile used in Egypt. Wool was not worn by priests or for religious rituals and was considered “unclean” although the Greek historian Herodotus (c. 490 B.C.E.) reported that he saw wool fabrics in use. From samples of fabric that have been preserved, it is evident that the Egyptians were highly skilled in linen production. They made elaborately pleated fabrics, probably by pressing dampened fabrics on grooved boards. Tapestry woven fabrics appeared after 1500 B.C.E. Beaded fabrics are found in tombs, as are embroidered and appliquéd fabrics.

**Major costume forms.** Draped or wrapped clothing predominated in Egyptian dress. Lower status men wore the simplest of garments: a loincloth of linen or leather, or a leather network covering a loincloth. Men of all classes wore wrapped skirts, sometimes called *schenti*, *shent*, *skent*, or *schent* by costume historians. The precise shape of these skirts varied depending on whether the fabric was pleated or plain (more often plain in the Old Kingdom, more likely pleated in the New Kingdom), longer or shorter (growing longer for high status men in the Middle Kingdom and after), fuller (in the New Kingdom) or less full (in the Old Kingdom). Royalty and upper-class men often wore elaborate jeweled belts, decorative panels, or aprons over skirts.

Coverings for the upper body consisted of leopard or lion skins, short fabric capes, corselets that were either strapless or suspended from straps, and wide, decorative necklaces. Over time the use of animal skins diminished. These became symbols of power, worn only by kings and priests. Eventually cloth replicas with painted leopard spots replaced the actual skins and seemed to have had a purely ritual use.

Tunics appear in Egyptian dress during the New Kingdom, possibly as a result of cross-cultural contact with other parts of the region or the conquest and political dominance of Egypt for a time by foreigners called the Hyksos.

Long wrapped garments appear to have been worn by both men and women until the Middle Kingdom, after which they appear only on women, gods, and kings. Instead during the New Kingdom men were shown wearing long, loose, flowing pleated garments, the construction of which is not entirely clear. Shawls were worn as an outermost covering and were either wrapped or tied.

Slaves and dancing girls were sometimes shown as being naked or wearing only a pubic band. Laboring women wore skirts when at work. Women, especially

those of lower socioeconomic status, wore long, loose tunics, similar to those worn by men. From the writings of Herodotus, it appears this garment was called a *kalasiris*. Some costume historians have mistakenly used this term to refer to a tightly fitted garment that appears on women of all classes. Although this garment has the appearance of a tightly fitted sheath dress, it is thought that this representation is probably an artistic convention, not a realistic view. The garment was more likely to have been a length of fabric wrapped around the body. Gillian Vogelsang-Eastwood (1993) in an extensive study of garments from Egyptian tombs has found no examples of sheath dresses, but has found lengths of cloth with patterns of wear that are consistent with such wrapped garments.

Sheathlike garments are often shown with elaborate patterns. Suggestions for how the patterns were made have included weaving, painting, appliquéd, leatherwork, and feathers. The more likely answer is that beaded net dresses, found in a number of tombs, were placed over a wrapped dress.

Garments from tombs from the Old Kingdom and after also include simple V-necked linen dresses made without sleeves. A later, sleeved version has a more complex construction that required sewing a tubular skirt to a yoke.

Like men, high status women wore long, full, pleated gowns in the New Kingdom. Careful examination of representations of these gowns indicates that the method of draping these garments that was used by women was different from those of men. Like men, women used wrapped shawls to provide warmth or cover.

Egyptian jewelry often provided the main sources of color in costume. Wide jeweled collars, jeweled belts and aprons, amulets worn around the neck to ward off evil, diadems with real or jeweled flowers, armlets, bracelets, and, during the New Kingdom, earrings were all part of the repertoire of ornaments available to men and women.

Headdress and hair coverings were often used to communicate status. As a result works of art show a wide variety of symbolic styles. The pharaoh wore a crown, the *pschent*, that was made by combining the traditional crown of Lower Egypt with the traditional crown of Upper Egypt. This crown was a visible symbol of the king's authority over both Upper and Lower Egypt. Other symbolic crowns and headdresses also are seen: the *bembemet* crown, worn on ceremonial occasions; the blue or war crown when going to war; the *wraeus*, a representation of a cobra worn by kings and queens as a symbol of royal power. The *nemes* headdress, a scarflike garment fitted across the forehead, hanging down to the shoulder behind the ears, and having a long tail (symbolic of a lion's tail) in back was worn by rulers. Queens or goddesses wore the falcon headdress, shaped like a bird with the wings hanging down at the side of the face.

Men, and sometimes women and children, shaved their heads. Although men were clean-shaven, beards

were symbols of power and the pharaoh wore a false beard. When artists depict Hatshepsut, a female pharaoh, she, too, is shown with this false beard. The children of the pharaoh had a distinctive hairstyle, the lock of Horus or the lock of youth. The head was shaved, and one lock of hair was allowed to grow on the left side of the head where it was braided and hung over the ear.

### Minoan Dress

While the Mesopotamian and Egyptian civilizations were flourishing in the Eastern Mediterranean, the island of Crete, farther to the west, was home to the Minoans. This people, named after a legendary king Minos, thrived from about 2900 to 1150 B.C.E. on the island of Crete. By 2100 B.C.E. the Minoans extended their influence to the mainland Greek city-state called Mycenae. After the Minoans went into decline in the period around 1400 B.C.E., the Mycenaean gained control over Crete and the Minoans.

Archaeological evidence provides a glimpse of Minoan and Mycenaean dress. From wall paintings and statuettes scholars have reached some conclusions about clothing of these periods. Archaeologists have determined that both linen and wool were produced. Wall paintings show Minoan textiles with intricate patterns that required both simple and complex weaving processes, embroidery, or painting. Excavations reveal that dyestuffs were imported. And Egyptian wall paintings showing men dressed in Minoan styles lead to the conclusion that Minoan traders brought their textiles to Egypt.

**Major costume forms.** Minoan dress had some similarities to and some marked differences from other Mediterranean civilizations. Leaping over the horns of bulls was a sport or religious ritual in which both Minoan men and women participated. Wall paintings show that for this sport, both wore loincloths reinforced at the crotch for protection. Minoan men wore skirts that ranged in length from short thigh-length versions with a tassel in the front, to longer lengths that ended below the knee or at the ankle. Skirts that appear to be very similar to the Mesopotamian *kaunakes* garment are also seen in Minoan art.

Women, too, wore skirts, but the construction was quite different from those of men. Scholars propose three different skirt types. All are full length. One is a bell-shaped skirt fitted over the hips and flaring to the hem. Another appears to be made of a series of horizontal ruffles widening gradually until they reach the ground, and the third is shown with a line down the center that some have interpreted as depicting a culotte-like, bifurcated skirt. Others see that line as merely showing how the skirt fell. With these skirts women often wore an apronlike overgarment. Arthur Evans, an archaeologist who was one of the earliest to study Cretan sites, suggested that the apron garment was worn for religious rituals and was a vestige of a loincloth worn by men and women in earlier times.

With these skirts, the top women wore a garment unique to the Minoans: a smoothly fitted bodice that, if the art is being accurately interpreted, had to have been cut and sewn. Tightly fitted sleeves were sewn or otherwise fastened onto the bodice. It laced or fastened underneath the breasts, leaving the bosom exposed. Authorities do not agree on whether all women bared their breasts. Some believe this style was restricted to priestesses and that ordinary women covered their breasts with a layer of sheer fabric.

With skirts or loincloths both men and women wore wide, tight belts with rolled edges. They also wore tunics. Men's were short or long; women's were long. Most of the tunics, as well as bodices and skirts, seem to have had woven patterned braid trimmings covering what appear to be the seam lines or points where garments would have been sewn together.

Men and women are both depicted with long or short curly hair. A variety of headwear can be seen in Minoan art, much of which may have been used in religious rituals or to designate status. Women are often shown with their hair carefully arranged and held in place with decorative nets or fillets (bands).

### Greek Dress

A "dark age" of which little is known separates the Minoan/Mycenaean period from the Archaic Period of Greek history on the mainland. The history of Ancient Greece is generally divided into the Archaic Period (800–500 B.C.E.), the Classical Age (500–323 B.C.E.), and the Hellenistic Period (after 323 B.C.E. to the absorption of Greece by the Romans).

Greek sculpture and vase paintings provide numerous illustrations of Greek costume as do some wall paintings. Some even show individuals putting on or taking off clothing; therefore, scholars believe they understand what was worn and how it was constructed. Color of clothing, however, can be problematic. When first created and displayed most sculpture had been painted with colors. Those colors have been bleached away over time. For many years people believed that Greeks wore white almost exclusively. Most vase paintings are not a good source for information about color because the traditions of vase painting showed either black figures on a red background or red figures on a black background. From the few white background vases on which figures were painted in color and from frescoes it is possible to see that Greeks wore a wide range of often vivid colors.

Married women in ancient Greece ran the household. They provided for the family's needs for textiles by spinning and weaving. Fibers used included wool, which was produced in Greece. Linen came to Greece by the sixth century B.C.E., probably making its way from Egypt to the Ionian region of Asia Minor, where some Greeks had settled, and from there to the Greek peninsula. Late in Greek history silk evidently came from China by way





**Woman on urn.** In ancient times, people in warmer climates wore draped clothing such as that depicted in this artwork. Garments of this nature were cooler and allowed freedom of movement. © THE CLEVELAND MUSEUM OF ART, THE ATALANTA LEKYTHOS, 1966.114. REPRODUCED BY PERMISSION.

of Persia, and the Greek island of Cos was known for its silk production. Imported woven silk fabrics were probably unraveled into yarns and then combined with linen yarns and woven into fabrics. In this way, less of the precious silk was needed to make a highly decorative fabric.

Dyes were made from plants and minerals. A particularly prized and valuable color was purple, which was obtained from shellfish. Dyeing, bleaching, and some other finishing processes were probably carried out in special facilities, not in the home, because of the noxious fumes they produced. Women were skilled in decorating fabric with embroidery and woven designs. Garments were draped and were most likely woven to the correct size and therefore required little cutting and sewing. Many garments appear to be pleated, so it is likely that there were devices for pressing pleats into fabric and for keeping textiles smooth and flat.

**Major costume forms.** The Greek name for the garment roughly equivalent to a tunic was *chiton*, which is what costume historians now call Greek tunics. Throughout Greek history one form or another of the chiton was the basic

garment for men, women, and children. Its size, shape, and methods of fastening varied over time. Even so, the chiton was constructed in much the same way throughout Greek history. A rectangular length of fabric was folded in half lengthwise and placed around the body under the arms with the fold on one side and the open edge on the other. The top of the fabric was pulled up over the shoulder in the front to meet the fabric in the back, and pinned. This was repeated over the other shoulder. This rudimentary garment was belted at the waist. Sometimes the open side was sewn or it may have been pinned or left open. By beginning with this simple garment, variations could be made easily. Often the top edge of the fabric was folded down to form a decorative overfold. The width of the folded section could vary. Belts could be placed at various locations or multiple belts could be used. The method of pinning the shoulder could also change.

The names used today for these different styles are not necessarily those given to them by the ancient Greeks, but have been assigned later by costume historians who sometimes differ about terminology. The terms employed here are those that appear to be most commonly accepted.

In the Archaic Period, the chiton type garments are known as the *chitoniskos* and the *Doric peplos*. Both had the same construction and were made with an overfold that came to about waist length. They appear to have been closely fitted and seem to have been made from patterned wool fabrics. Men wore the *chitoniskos*, which was usually short and ended between the hip and the thigh. Women wore the *Doric peplos*, similar in shape and fit but reaching to the floor. The *Doric peplos* was fastened with a long, sharp, daggerlike decorative pin.

Herodotus says that the transition from the *Doric peplos* to the *Ionic chiton* came about because the women of Athens were said to have used their dress pins to stab to death a messenger who brought them the news of the resounding defeat of the Athenians in a battle. Herodotus says that the use of these large pins was outlawed, and small fastenings mandated instead.

This story may be apocryphal, but it is true that the *Ionic chiton* did replace the *Doric peplos* for both men and women soon after 550 B.C.E. The *Ionic chiton* was made from a wider fabric and was pinned with many small fasteners part or all of the way down the length of the arm. With more fabric in the garment, overfolds were less likely to be used. Instead other shawls or small rectangular garments were placed over the chiton. Many of the wider *Ionic chitons* appear to be pleated and were most likely made of lighter weight wool or of linen. Styles could be varied by belting the fabric in different ways.

Around 400 B.C.E. the *Ionic chiton* gradually gave way to the *Doric chiton*. The *Doric chiton* was narrower and fastened at the shoulder with a single pin very much like a decorative safety pin. The Romans called such pins *fibulae* and this Latin term is now used for any such pin



from ancient times. This garment was more likely than the Ionic chiton to have an overfold. Doric chitons could also be worn with the previously mentioned small draped garments and belted in various ways. They seem to have been made from wool, linen, or silk.

Some scholars see the transition from the large, ostentatious Ionic chiton to the simpler Doric chiton as reflecting changes in attitudes and values in Greek society. A. G. Geddes (1987) suggests that in the late fifth century B.C.E. emphasis was being placed on physical fitness (more obvious in the more fitted Doric chiton), equality, and less flaunting of wealth.

The Hellenistic chiton appears from around 300 to 100 B.C.E. It was a refinement of the Doric chiton that was narrower, belted just beneath the breasts, and made of lighter weight wool cloth, linen, or silk. It is this chiton that is closest in style to many of the later garment styles that were inspired by the Greek chiton.

In general, styles for men and women were very similar, with women's garments reaching to the floor and men's more likely to be short for daily use. A poor man's version of the chiton was the *exomis*, a simple rectangle of cloth that fastened over one shoulder, leaving the other arm free for easier action.

Several garments seem to have been used more by men than women. The *himation* was a large rectangle of fabric that wrapped around the body. In use from the late fifth century, the garment might be worn alone or over a chiton. It covered the left shoulder, wrapped across the back and under the right arm, then was thrown over the left shoulder or carried across the left arm. For protection against inclement weather and while traveling, men wore a rectangular cloak of leather or wool called the *chlamys*. It could also be used as a blanket. The *petasos*, a wide-brimmed hat that offered additional protection against sun or rain was often worn with this cloak.

The question of whether married, adult Greek women were required to be veiled when out-of-doors is still debated. Some statues do seem to show this. A respectable married woman's activities were limited; most of her time was spent in the home and she was excluded from men's social gatherings. The women shown socializing with men in Greek art are courtesans or entertainers, not wives. Some scholars believe that when a woman went outside the home, she pulled a mantle or veil over her head to obscure her face. C. Galt (1931) suggests that veiling came to Greece from Ionia in the Middle East about the time the Ionian chiton was adopted.

### Etruscan Dress

A number of tribes occupied the Italian peninsula. By 800 B.C.E. one of these groups had occupied a fairly large area and had developed an advanced culture and economy. Their burial practices, which included tomb paintings showing daily life, provide good evidence for how they dressed.

Trade brought them into close contact with Greece, Greek art, and Greek styles. In some periods Etruscan costume shows more shaping in the sleeves, which flare out at the ends, and a fit that molds the body more closely. Other distinctively Etruscan garments included a tall peaked hat, called a *tutulus*; shoes with pointed, curved toes; and several different styles of mantles. One especially notable mantle was the *tebenna*, which was apparently made with curved edges and semicircular in shape. Scholars believe that this mantle was the forerunner of the Roman toga. Even though individual characteristics can be noted for some Etruscan styles, for the most part Etruscan and Greek costumes show so many similarities that Etruscan versions are virtually indistinguishable from the Greek.

As the Romans rose to power in Italy, the Etruscans were absorbed into Rome and by the first century B.C.E. no longer existed as a separate culture.

### Roman Dress

A tribe occupying the hills near the present city of Rome, the Romans gradually came to dominate not only the Italian peninsula, but a vast region including present-day western Europe and large parts of the Middle East and North Africa. Because much of the Mediterranean region had been under the domination of Greece, Greek influences permeated much of Roman life. Dress was no exception. As with the Etruscans, it is often difficult to distinguish between Greek and Roman styles. However, Roman dress is far more likely than Greek to include elements that identify some aspect of the status of the wearer.

Not only are there ample works of art remaining from the Roman era, but also literary works and inscriptions in Latin that can be read and understood. Even so, some aspects of Roman dress are not clearly understood. The precise meaning of certain Latin words referring to clothing may not be clear. One example is a man's garment called the *synthesis*.

The *synthesis* was a special occasion garment, worn by men for dinner parties. The traditional Roman man's garment, the toga, was cumbersome. Romans reclined to eat, and apparently it was difficult to stretch out in a toga, so the *synthesis* was the solution to this awkwardness. Based on what Roman texts say about the garment, scholars have concluded that it was probably a tunic worn with a shoulder wrap. But there does not appear to be any depiction of the style in Roman art.

Wool, linen, and silk were used in Rome and apparently cotton was imported from India around 190 B.C.E. or before. Silk was available only to the wealthy; cotton might be blended with wool or linen. Textiles were not produced in the family home, as in Greece. Instead they were woven by women workers on large estates or by men and women in businesses located throughout the empire. While some clothing was made in the home, ready-to-wear clothing was also available in shops.

The Roman version of the *chiton* was called *tunica*, from which the word tunic derives. Roman men's tunics ended at about the knee and were worn by all classes of society. Bands of purple that extended vertically from one hem to the other across the shoulder designated rank. Tunics of the Emperor and senators had wider bands; those of knights had narrower bands. Precise placement and width of these bands, called *clavi*, changed somewhat at different time periods, and after the first century C.E. all male nobles wore these bands. At this time ordinary citizens and slaves had no such insignia, but later they became more common. All male citizens were expected to wear the toga over a tunic.

The toga was the symbol of Roman citizenship. It was draped from a semicircle of white wool and placed across the shoulder, around the back, under the right arm, and pulled across the chest and over the shoulder. As previously noted it probably derived from the Etruscan *tebenna*. Some officials wore special togas and throughout the history of Rome the size, shape, and details of draping did change somewhat.

Various types of cloaks and capes, with or without hoods, served to provide cover outdoors. Those worn by the military often identified their rank. The *sagum* was a red wool cape worn by ordinary soldiers. This term entered into the lexicon of symbols, and when people talked about "putting on the sagum" they meant "going to war."

Women's dress in Rome differed only a little from that of Greek women of the Hellenic period. They wore an under tunic, not seen in public, and an over tunic very much like a Greek *chiton*. A *palla*, rather similar to a Greek *himation*, was draped over this. The colors of these layers varied. Opinions differ as to just what the *stola* with the *instita* was. Many costume histories use the word *stola* interchangeably with outer tunic. However, literary works clearly indicate that the garment was associated only with free, married women. Some sources describe the *instita* as a ruffle at the bottom of the *stola* or outer tunic. But a careful analysis by Judith Sebesta (1994) leads her to conclude that it is a special type of outer tunic suspended from sewed-on straps.

Hairstyles show marked differences from one time period to another. Men are generally bearded during the years of the Republic, clean-shaven during the Empire until the time of the Emperor Hadrian who wore a beard. Each family celebrated the occasion of the first shave for a young boy with a festival at which they placed the hairs in a special container and sacrificed them to the gods.

Women's hairstyles were relatively simple during the first century C.E., but later grew so very complicated that they required the addition of artificial hair and special curls and braids arranged into towering structures.

Literary sources speak of extensive use of makeup by both men and women. Cleanliness was valued and public baths available to all levels of society.

The children of Roman citizens dressed like adults. Both boys and girls wore a toga with a purple band around the edge (*toga praetexta*). Boys wore it until age fourteen to sixteen, after which they wore the citizen's toga (*toga pura*), and girls gave it up after puberty. Initially this garment was only for the children of noble families, but eventually became part of the dress of all children of Roman citizens. Roman male children also wore a *bulla*, a ball-shaped neck ornament containing protective charms that was given to them at the time they were named.

Both brides and vestal virgins, women whose lives were dedicated to the goddess Vesta, seem to have worn a special headdress. It consisted of pads of artificial hair alternating with narrow bands. A veil was placed over this. For brides the veil was bright orange and a wreath made of orange blossoms and myrtle was set on top of it. This association of veils and orange blossoms with weddings continues until modern times and may have its origin in Roman custom.

See also **Textiles, Prehistoric; Toga.**

**BIBLIOGRAPHY**

*General Works*

Barber, E. J. W. *Prehistoric Textiles*. Princeton, N.J.: Princeton University Press, 1991.

———. *Women's Work: The First 20,000 Years*. New York: W. W. Norton and Company, 1994.

Born, W., III. "Footwear of the Ancient Orient." *CIBA Review* p. 1210.

Sichel, Marion. *Costume of the Classical World*. London: Batsford Academic and Education, 1980.

Tortora, Phyllis, and Keith Eubank. *Survey of Historic Costume*. New York: Fairchild Publications, 1998.

*Mesopotamian and Egyptian Dress*

"Herodotus on Egypt." Reprinted in *The World of the Past*. Vol. 1. Edited by J. Hawkes. New York: Alfred A. Knopf, 1963.

Houston, Mary G. *Ancient Egyptian, Mesopotamian, and Persian Costume*. New York: Dover Publications, Inc., 2002.

Vogelsang-Eastwood, Gillian. *Pharaonic Egyptian Clothing*. Leiden, Netherlands: E. J. Brill, 1993.

*Minoan and Greek Dress*

Evans, A. "Scenes from Minoan Life." In *The World of the Past*. Edited by J. Hawkes. New York: Alfred A. Knopf, 1963.

Evans, M. M. "Greek Dress." In *Ancient Greek Dress*. Edited by M. Johnson. Chicago, Illinois: Argonaut, Inc., 1964.

Faber, A. "Dress and Dress Materials in Greece and Rome." *CIBA Review* no. 1 (n.d.): 297.

Galt, C. "Veiled Ladies." *American Journal of Archeology* 35, no. 4 (1931): 373.

Geddes, A. G. "Rags and Riches: The Costume of Athenian Men in the Fifth Century." *Classical Quarterly* 37, no. 2 (1987): 307–331.

Houston, Mary G. *Ancient Greek, Roman, and Byzantine Costume*. Mineola, N.Y.: Dover Publications, Inc., 2003.

*Etruscan and Roman Dress*

- Bonfante, Larissa. *Etruscan Dress*. 2nd ed. Baltimore, Md.: Johns Hopkins University Press, 2003.
- Croom, Alexandra T. *Roman Clothing and Fashion*. Charleston, S.C.: Tempus Publishing Inc., 2000.
- Goldman, N. "Reconstructing Roman Clothing." In *The World of Roman Costume*. Edited by J. L. Sebesta and L. Bonfante, 213–237. Madison: University of Wisconsin Press, 1994.
- McDaniel, W. B. "Roman Dinner Garments." *Classical Philology* 20 (1925): 268
- Rudd, Niall, trans. *The Satires of Horace and Persius*. Baltimore, Md.: Penguin Books, 1973.
- Sebesta, Judith Lynn. "Symbolism in the Costume of the Roman Woman." In *The World of Roman Costume*. Edited by J. L. Sebesta and L. Bonfante, 46–53. Madison: University of Wisconsin Press, 1994.
- . "Tunica Ralla, Tunica Spissa." In *The World of Roman Costume*. Edited by J. L. Sebesta and L. Bonfante, 65–76. Madison: University of Wisconsin Press, 1994.
- Sebesta, Judith Lynn, and Larissa Bonfante, eds. *The World of Roman Costume*. Madison: University of Wisconsin Press, 1994.
- Stone, S. "The Toga: From National to Ceremonial Costume." In *The World of Roman Costume*. Edited by J. L. Sebesta and L. Bonfante, 13–45. Madison: University of Wisconsin Press, 1994.
- Wilson, Lillian May. *The Roman Toga*. Baltimore, Md.: Johns Hopkins University Press, 1924.
- . *The Clothing of the Ancient Romans*. Baltimore, Md.: Johns Hopkins University Press, 1938.

*Phyllis Tortora*

**ANGORA** Though true angora fiber is from the hair of the Angora rabbit, because more than one animal bears the name "angora" some confusion exists regarding what really is angora fiber. Angora rabbits produce angora fiber, and Angora goats produce mohair fiber. Angora also differs from rabbit hair, which is the fiber obtained from the common rabbit, in that angora is longer and more flexible and better suited for luxury textiles.

Each rabbit produces ten to sixteen ounces of luxuriously soft fiber per year. The rabbits are clipped with a pair of scissors, sheared with electric clippers, or plucked by hand when the hair is three to five inches long. Plucking pulls the loose hair from the rabbit and produces the highest grade of angora wool because of the spiky fur-like quality it gives to the fabric. Some countries regard plucking as inhumane and have outlawed the practice.

Angora fiber differs from sheep's wool in several ways. Unlike wool, angora fibers do not have scales on their surface. This lowers the risk of shrinkage from felting (the permanent interlocking of the fibers) and makes the fibers slippery. Angora fiber's diameter is very fine,

approximately 11 microns (1/25,000 of an inch). Only the finest wool is similar in diameter to angora. Angora fiber has a low density (weight) of 1.15 to 1.18 grams per cubic centimeter, compared to 1.33 for wool. Angora fibers have little elasticity, making them difficult to process into yarn. Wool, on the other hand, is very elastic because of its crimp and molecular structure. Blending angora with wool helps make spinning easier and helps to hold the angora in the yarn structure. During a garment's life, it is normal for short angora fibers to work their way out of the yarn and shed from the fabric.

Angora's small diameter fibers have air-filled chambers that give them warmth without weight. The fiber transmits moisture readily, so garments feel dry, warm, and comfortable. Angora's properties are of value not only for fashionable garments, but also for therapeutic garments designed for people with joint diseases. Garments featuring angora fiber include knitted sweaters, hats, gloves, and underwear for fall and winter-wear.

The highest quality commercial angora fiber is white, but the fiber is available in other beautiful colors including pure white, gray, fawn (a light grayish brown), brown, and black. Angora does not take dye well, so the dyed fiber usually has a lighter color than other fibers in the blend.

There are five grades of angora fiber. The first four require the fiber to be white, perfectly clean, and without tangles or mats. The lengths vary according to the grade: grade one, the top grade, is 2 to 3 inches long; grade two is 1.5 to 2 inches; grade three is 1 to 1.5 inches; and grade four is any length. Grade five is of any color and can be soiled and matted or unmatted. Naturally colored angora fiber is generally found in garments produced by small-scale manufacturers.

Angora rabbits were originally raised in North Africa and France. In the early twenty-first century, 90 percent of the world's production was from China. Other countries producing angora included Argentina, Chile, Hungary, France, and India.

*See also* **Felt; Fibers.**

**BIBLIOGRAPHY**

- Spalding, K., and C. McLelland, eds., *Angora Handbook*. 2nd ed. Morgan Hill, Calif.: Northern California Angora Guild, 1991.

*Ann W. Braaten*

**ANIMAL PRINTS** Animal prints and skins are widely believed to convey power to the wearer. Fabrics with patterns and colors imitating the skins of animals were made into fashionable dress as early as the eighteenth century, when elaborate silk designs emulating exotic furs intertwined with expensive laces to evoke a sense of luxury and wealth.





**Model wearing coat from Dolce & Gabbana collection.** Leopard prints such as this are favorites of the fashion world, conveying a sense of boldness, independence, and power upon the wearer. © ASHBY DON/CORBIS SYGMA. REPRODUCED BY PERMISSION.

Characteristics associated with a particular animal, such as the fierceness of a tiger, are thought to be transferred to the wearer through animal-patterned clothing. Animal motifs are also widely regarded as erotic and thus tend to be utilized on clothing designed to attract others. For example, animal prints have a constant presence in overtly sexual lingerie. A person wearing an animal print makes a statement about confidence and expresses a desire to be noticed. These head-turning prints catch the viewer's attention with their multicolored patterns and irregular designs. Their reputation ranges from classic and sophisticated in high fashion to cheap and trashy in popular fashion. Mainstream fashion articles have suggested that wearers limit animal prints to accents to avoid sending an overly suggestive message.

From tiger stripes to cheetah spots, the patterns of the world's big cats have been constants in the fashion world. The rosette pattern of the leopard has been a favorite. Graceful and powerful hunters, they suggest "feminine" cunning and instinct. The movie *Tarzan the Ape Man* was a huge success when it was released by MGM in 1932. The

revealing, leopard-patterned clothing of stars Johnny Weissmuller as Tarzan and Maureen O'Sullivan as Jane, created a sensation for leopard and cheetah prints during the 1930s. Blouses, coats, and scarves were some of the popular items made in animal prints during that time. These items represented the excitement and adventure of the jungle and an independence of spirit especially unusual for depictions of women during that time.

The fashion designer Rudi Gernreich produced a collection of animal-patterned dresses with matching tights and underwear in 1968, documented in the movie *Basic Black* (1968) by the photographer William Claxton and the model Peggy Moffitt. Animal prints became very popular for dresses, leggings, and accessories in the 1970s and 1980s. Animal pelts and prints fit the free-spirited independence and heightened interest in world cultures in the 1970s. Animal motifs were perfectly suited to the combination of extravagance, bold patterns, and color in the 1980s. The fashion designers Domenico Dolce and Stefano Gabbana have made animal prints their signature. These prints enhance the diva persona of the celebrities they are known for dressing.

Political questions concerning the use of real leather and animal fur have affected the wearing of animal prints. International law prohibits the trade in endangered species. By raising the awareness of the treatment of animals that are killed for the use of their skins, animal rights activists and organizations have promoted wearing clothing made of fabric printed with animal motifs rather than actual pelts.

See also **Dolce & Gabbana; Film and Fashion; Fur; Gernreich, Rudi.**

#### BIBLIOGRAPHY

Dolce, Domenico, and Stefano Gabbana. *Dolce & Gabbana: Animal*. Photography by Steven Meisel and Bruce Weber. New York: Abbeville Press, Inc., 1998.

Felderer, Brigitte, et al. *Rudi Gernreich: Fashion Will Go Out of Fashion*. Edited by Gerald Zeigerman. Philadelphia: Institute of Contemporary Art, University of Pennsylvania, 2001.

*Dennita Sewell*

**AO DAI** Vietnam's national dress, the *ao dai* (literally "long shirt"; pronounced "ow zai" in the north, "ow yai" in the south) consists of two elements: a long tunic with a close-fitting bodice, mandarin collar, raglan sleeves, and side slits that create front and back panels from the waist down; and wide-legged pants, often cut on the bias. While in the past both men and women wore *ao dai*, in the twenty-first century it is almost exclusively a women's garment. A popular uniform for civil servants, tour guides, hotel and restaurant staff, and high school students, the *ao dai* is also worn for weddings, religious rituals, and special occasions. Commonly seen as symbolizing traditional Vietnamese identity and femi-





**Beauty pageant contestants in Vietnam.** The *ao dai*, with its characteristic long shirt, mandarin collar, and loose-fitting trousers, enjoyed a revival in the 1990s, and is worn for special occasions, as well as by office workers and students. © STEVE RAYMER/CORBIS. REPRODUCED BY PERMISSION.

ninity, the *ao dai* in fact has a relatively brief history marked by foreign influence.

### History

The *ao dai* provides a striking example of how Vietnamese have responded to both Chinese and French colonization by adopting elements of foreign cultures and modifying them to be uniquely Vietnamese. Prior to the fifteenth century, Vietnamese women typically wore a skirt (*vay*) and halter top (*yem*). These were sometimes covered by an open-necked tunic (*ao tu than*) with four long panels, the front two tied or belted at the waist. Women's garments were brown or black, accented by brightly colored tops or belts on special occasions. From 1407 to 1428, China's Ming Dynasty occupied Vietnam and forced women to wear Chinese-style pants. After regaining independence, Vietnam's Le Dynasty (1428–1788) likewise criticized women's clothing for violating Confucian standards of decorum. These policies were haphazardly enforced, and skirts and halter tops remained the norm. During the seventeenth and eighteenth centuries, Vietnam was divided into two regions, with the Nguyen family ruling the south. To distinguish their sub-

jects from northerners, Nguyen lords ordered southern men and women to wear Chinese-style trousers and long, front-buttoning tunics. After the Nguyen family gained control over the entire country in 1802, the conservative Confucian Emperor Minh Mang (r. 1820–1841) banned women's skirts (*vay*) on aesthetic and moral grounds.

Over the next century, precursors to the modern *ao dai* became popular in cities, at the royal court in Hue, and for holidays and festivals in the countryside. With some regional variations, the outfit consisted of pants and a loose-fitting shirt with a stand-up collar and a diagonal closure that ran along the right side from the neck to the armpit, both features inspired by Chinese and Manchu garments. Elites often layered several *ao dai* of different colors, with the neck left open to display the layers. Among peasants and laborers, however, the *vay* and *yem* remained popular for daily wear.

Under French colonialism (1858–1954), Vietnamese intelligentsia and an emerging urban bourgeoisie strove to adopt progressive elements of Western modernity while at the same time resisting colonialism and preserving select aspects of Vietnamese heritage. During the

1930s, as part of the efforts of Tu Luc Van Doan (Self-Reliance Literary Group) to fashion a modern “new woman,” Hanoi artist Nguyen Cat Tuong, also known as Lemur, premiered ao dai styles inspired by French fashion. The light-colored, close-fitting tunics featured longer panels, puffy sleeves, asymmetrical lace collars, buttoned cuffs, scalloped hems, and darts at the waist and chest, thus requiring a brassiere or corset. Lemur’s Europeanized flared pants were white with snugly tailored hips. Criticized by conservatives as scandalous, Lemur’s designs nonetheless marked the emergence of a contemporary ao dai blending traditional Vietnamese elements with Western tailoring and bodily aesthetics, much like the Chinese cheongsam of the same period.

French colonialism ended in 1954 with the division of Vietnam into North and South. In North Vietnam, communist leaders criticized the ao dai as bourgeois, colonial, and impractical for manual labor, although women continued to wear it for special occasions. Meanwhile, in capitalist South Vietnam, experimentation with the garment continued. Madame Nhu (Tran Le Xuan), the sister-in-law of President Ngo Dinh Diem, became notorious in the 1950s and 1960s for the skin-baring open necklines of her ao dai. Also at this time, two Saigon tailors redesigned the ao dai to include raglan sleeves, thus reducing wrinkling around the shoulders and armpits.

### Revival

In 1975, the Vietnam War ended with the reunification of North and South under communist rule. Leaders decried the southern ao dai as decadent and instead promoted simpler, utilitarian clothing styles. But austerity proved short-lived. By the 1990s, economic reforms and improved standards of living led to a revival of the ao dai within Vietnam and to growing international awareness of it as a symbol of Vietnamese identity. In 1989, the *Women’s Newspaper* in Ho Chi Minh City (formerly Saigon) hosted the first Miss Ao Dai contest. Six years later, Miss Vietnam’s blue brocade ao dai won the prize for best national costume at Tokyo’s Miss International Pageant. Simple white ao dai have been reinstated in many cities and towns as uniforms for female high school students, while Vietnam Airlines flight attendants don red ao dai. Recent innovation has come in both decoration and form. The designers Si Hoang and Minh Hanh employ novel fabrics, abstract motifs, and ethnic minority patterns, while others alter the tunic by opening necklines, removing sleeves, or replacing the long panels with fringe. The once scandalous white pants now seem outmoded, and urban women instead favor pants the same color as the tunic. Although most Vietnamese women wear Western dress daily, the ao dai allows the fashion-conscious to be simultaneously trendy and traditional on special occasions.

### International Influence

When the ao dai fell into disfavor in socialist Vietnam, Vietnamese who had immigrated to the United States,

Canada, Australia, or France preserved it as a symbol of their ethnic heritage. Ao dai can be seen at fashion shows, Tet (Lunar New Year) celebrations, weddings, and musical performances throughout the diaspora, which numbered approximately 2.5 million in 2003. Like the Chinese cheongsam and the Japanese kimono, the ao dai has also inspired non-Asian designers. Following the 1992 films *Indochine* and *The Lover*, both set in the French colonial period, Ralph Lauren, Richard Tyler, Claude Montana, and Giorgio Armani debuted ao dai-inspired collections. While “Indo-Chic” fashions can be Orientalist in their celebration of a demure, sexy, and exotic Vietnamese femininity, they are typically welcomed in Vietnam as evidence that the ao dai has entered the canon of international fashion. The ao dai’s twenty-first-century revival in Vietnam rests as much on this newly fashionable status as on its links to the past.

See also **Asia, Southeastern Mainland: History of Dress; Qipao; Shirt.**

### BIBLIOGRAPHY

- Doan Thi Tinh. *Tim Hieu Trang Phuc Viet Nam*. Hanoi, Vietnam: Nha Xuat Ban Ha Noi, 1987.
- Leshkovich, Ann Marie. “The *Ao Dai* Goes Global: How International Influences and Female Entrepreneurs Have Shaped Vietnam’s ‘National Costume.’” In *Re-Orienting Fashion: The Globalization of Asian Dress*. Edited by Sandra Niessen, Ann Marie Leshkovich, and Carla Jones. Oxford and New York: Berg, 2003.
- Ngo Duc Thinh. *Trang Phuc Co Truyen Cac Dan Toc Viet Nam*. Hanoi, Vietnam: Van Hoa Dan Toc, 1994.
- Nguyen Ngac, and Nguyen Van Luan. *Un siècle d’histoire de la robe des Vietnamiennes*. Saigon, Vietnam: Direction des Affaires Culturelles, 1974.
- Nguyen Thi Duc. *Van Hoa Trang Phuc tu Truyen Thong den Hien Dai*. Hanoi, Vietnam: Nha Xuat Ban Van Hoa Thong Tin, 1998.
- Nguyen Van Ky. *La société Vietnamiennne face à la modernité*. Paris: L’Harmattan, 1995.
- Nhi T. Lieu “Remembering the Nation Through Pageantry: Femininity and the Politics of Vietnamese Womanhood in the *Hoa Hau* Ao Dai Contest.” *Frontiers* 21, no. 1/2 (2000): 127–151.

*Ann Marie Leshkovich*

**APPEARANCE** The term “appearance” is commonly used in relation to the observable characteristics of a wide range of things in the environment such as human beings, plants and animals, geographical and atmospheric conditions, and buildings, to name only a few. However, this entry will be limited to a discussion of appearance in relation to the human body along with things placed on or about it in functioning as stimuli for communication.

Human beings have the capability of communicating in many different ways, often simultaneously. Ap-

pearance, because of visual characteristics and the versatility with which they can be structured to send various messages, is used frequently as a type of nonverbal communication as the primary focus of attention or in conjunction with other forms of communication.

### **The Body and Dress**

For purposes of study and analysis, appearance can be considered according to two major components: the body and dress. Because the characteristics of each are complex, there is merit in considering them independently before examining their interrelatedness.

**The body component.** A wide range of observable characteristics of the body serve as stimuli during the process of communication. They fall into four main categories: body forms, body motions, body surfaces, and facial configurations. The category of body forms includes characteristics pertaining to the overall structure of the body in a fixed position as well as the structure of various units such as the head and limbs, each of which provides a different kind of stimuli in appearance. Because body forms include size, shape, and mass, they are among the most compelling aspects of appearance.

The category of body motions pertains to interrelationships between movement and the totality of the body as well as certain parts. Gait, hand gestures, shoulder shrugs, nods, and pelvic movements all fall into this category. Dynamic effects are often produced in appearance through the tempo and rhythm of body motions.

The category of body surfaces pertains to characteristics of coverings of the overall body and its parts such as the color and texture of skin and hair. Because body surfaces appeal to both the senses of touch and sight, they can be among the most sensuous qualities of appearance.

The category of facial configurations pertains to forms, motions, and surfaces that are unique to the face. Since the face is composed of various forms, has potential for movement, and has color and texture in skin and hair, this category is an integration of characteristics that are similar to those in the other categories but on a smaller scale. However, since the face is a particularly expressive part of the body and often serves as a major source of stimuli in appearance, there is merit in considering facial configurations as a category apart from its counterparts in the overall body composition.

Each of the four categories of the body component can be analyzed further on the basis of constituent parts referred to as elements. In addition to contributing to the totality of a major characteristic of the body, each has the potential of being a dominant aspect of appearance unto itself. For example, eye movements are among the mix of elements that constitute the overall characteristics of facial configurations, but they can also command special attention when they occur in such forms as unexpected winks or sudden blinks. In a similar way, skin color and texture are integrated characteristics of body surfaces, but

they can also be dominant features of appearance when they stand out for some reason.

In prehistoric times, appearance was based solely on the body since the concept of dress had not yet evolved. However, there is considerable documentation that even in the early years, the body was modified in various ways apart from donning items of clothing. Substances were discovered in nature that could be used to change the color and texture of both skin and hair and technological innovations were made that could change the size, shape, and contours of the body.

**The dress component.** As knowledge about materials expanded and skills concerning processes and techniques emerged, new ways of protecting and enhancing the body began to appear. Although scholars have referred to the classification of those innovations in various ways, they are referred to as dress in this entry.

Characteristics of dress fall into two main categories: articles of clothing and articles of adornment. The term “clothing” pertains to things that are placed over the body to bring about comfort or protection whereas the term “adornment” is used in reference to items that are placed on or about the body to enhance it. However, the dividing line is not always clear since clothing can serve as adornment and under certain circumstances, adornment functions as clothing.

Just as various categories of the body can be considered according to elements, so can the categories of clothing and articles of adornment. Materials, processes, and techniques function as elements in both the categories of clothing and adornment. New and compelling characteristics of both clothing and adornment are often the result of advancements in materials or innovations that have come about through processes and techniques.

In addition to serving different functions, clothing and adornments differ in other ways. Materials used for clothing are most likely to be softer and more pliable than those used for adornments. Since comfort and protection are often desirable qualities in clothing, characteristics of body forms, motions, and surfaces tend to be taken into greater consideration in clothing design than they are in that of adornment.

**Interrelationships between the body and dress.** Appearance is the result of various configurations of the body operating either independently or in conjunction with dress. As persons are born, raised, and socialized into a culture, they are introduced to prevailing standards of appearance, some of which pertain to the body, others to dress. They learn to assemble configurations of appearance from a wide assortment of elements pertaining to the body and dress. Some of those elements remain fixed for long periods whereas others are temporary.

A person’s appearance undergoes considerable change throughout the life cycle; however, some influences account for more rapid changes than others. Physical



characteristics, notions about beauty, and the influence of social and cultural norms about dress are more likely to evolve slowly whereas attitudes about material culture and lifestyle usually change more rapidly.

As cultures evolved in various parts of the world, appearance became increasingly important as a medium of self-expression and communication. Overall, body factors have tended to provide useful information about gender, age, race, ethnicity, physical conditions, and origins of human beings whereas dress has conveyed clues pertaining to individual and collective forms of expression, resourcefulness, technical expertise, attitudes about social class, and belief systems along with a wide range of other social and cultural factors.

In contemporary cultures of both the East and West, appearance has evolved into a rapidly changing complex interrelationship between components of the body and dress. In addition to being the result of ongoing cultural evolution that interrelationship has been nurtured by various economic-driven industries, such as print and electronic media, cosmetology, film, fashion, and more and more, cosmetic surgery. Participants of contemporary culture are exposed to a multitude of new images for changing appearance along with corresponding products for bringing them about. Once those images are adopted, persons are encouraged to both abandon and replace them with even more recent images, thereby maintaining an ongoing cycle of appearance change.

See also **Clothing, Costume, and Dress; Fashion and Identity.**

#### BIBLIOGRAPHY

Hillestad, Robert. "The Underlying Structure of Appearance." *Dress, The Journal of the Costume Society of America* 6 (1980): 117–125.

Robert Hillestad

**APPLIQUÉ** Appliqué is a decorative surface design technique that adds dimension and texture to the background fabric. The term derives from the French word *appliquer* (and the Latin *applicare*) that means to join or attach. While its early use was most likely to strengthen worn areas or serve as a patch over holes, appliqué developed into a creative art form used by many cultures over many centuries. Traditional appliqué is defined as laying pieces of fabric on top of the background fabric to form a pattern or picture. Intricate appliqués may have numerous colors and use many layers of fabrics. After each individual piece of fabric is cut out, the raw edges are turned under and hand-sewn to the background fabric using an invisible stitch. The invention of new materials (water dissolvable stabilizer, glue sticks, and fusible web), the development of new techniques, and acceptance of new standards (machine sewing vs. hand sewing) have made appliqué faster and easier to do and are responsible for its continued popularity.

A variation of traditional appliqué is *broderie perse* (Persian embroidery), or chintz appliqué. This technique involves cutting small motifs from printed fabrics and arranging them together into a design or pattern. The opposite of traditional appliqué is reverse appliqué. All of the fabrics that are going to be in the design are layered. Cutting down to expose the layers forms the pattern. The raw edges are turned under and sewn to the next fabric. The Kuna Indians who live on the San Blas Islands off the coast of Panama make their molas using this technique. The patterns range from modern graphics to traditional themes from their legends and culture. A variation on reverse appliqué is known as inlay appliqué. The desired shape is cut out from the background fabric. A second fabric is placed behind the opening and the turned under edges of the background opening are sewn to the new fabric. Any excess fabric is trimmed away. Appliqués can also be three-dimensional, extending above the surface of the background fabric.

Starting with the ancient Egyptians, examples of appliqué can be found on garments and household items in every part of the world. During the Middle Ages elaborate appliqué was used on heraldic and ecclesiastical banners and ceremonial clothing. Appliqué is a part of the decoration on national (festival) costumes (eighteenth and nineteenth centuries) and ethnic folk dress. Several appliquéed garments are associated with the twentieth century. The Irish dance competition dress, which was relatively unadorned in the 1950s, evolved into an elaborately appliquéed and embroidered garment by the end of the century. The poodle skirt, circa 1955, was a felt circle skirt with a poodle (or other design) appliqué. The hippies, or flower children, of the mid 1960s, decorated and customized their apparel with appliqués. Wearable artists use appliqués to create one-of-a-kind garments. Many fashion designers have used appliqué in their lines: Elsa Schiaparelli, Franco Moschino, Gianni Versace, Bob Mackie, and Christian Francis Roth are examples. Koos van den Akker's entire line is devoted to quilted, appliquéed collages.

See also **Embroidery; Moschino, Franco; Schiaparelli, Elsa; Versace, Gianni and Donatella.**

#### BIBLIOGRAPHY

Avery, Virginia. *The Big Book of Applique*. New York: Charles Scribner's Sons, 1978.

Teufel, Linda Chang. *Koos Couture Collage: Inspiration and Techniques*. Worthington, Ohio: Dragon Threads, 2002.

Nan H. Mutnick

**APRONS** "Apron" means an over-garment covering the front of the body (from the French *naperon*, a small tablecloth). For centuries, people worldwide have worn them as protective garments, as ceremonial indicators of marital and parental status, rank and group affiliation, and as decorations.



Cretan fertility goddesses and Assyrian priests wore sacred aprons. Egyptian rulers broadcast their status by wearing jewel-encrusted aprons. In Europe during the Middle Ages, women placed extra swaths of cloth in their laps to protect their skirts during rowdy communal meals, and tradesmen and artisans began wearing aprons to protect their clothing and their flesh. In fact, tradesmen in general were called “apron men,” as aprons were so common that several trades boasted distinguishing styles. Gardeners, spinners, weavers, and garbagemen wore blue aprons; butlers wore green; butchers wore blue stripes; cobblers wore “black flag” aprons for protection from the black wax they used; and English barbers were known as “checkered apron men.” Stonemasons wore white aprons as protection against the dust of their trade, and even in the twenty-first century, aprons survive as part of Masonic ceremonial attire. In contemporary South Africa, young women wear beaded aprons to celebrate their coming of age.

By 1500, decorative aprons had become fashion accessories for European women with lifestyles permitting such luxury and display. Their popularity waxed and waned over the centuries. By the time colonists settled in North America, aprons were firmly established in European women’s wardrobes.

### United States Aprons

Aprons were worn by some Native American women and men, for both practical and ceremonial reasons. Through the centuries, colonial immigrants and their descendants have worn functional aprons for work, while decorative aprons have fallen in and out of fashion.

Looking back just one century, from 1900 through the 1920s, well-heeled women wore ornate, heavily embroidered aprons. In the 1930s and 1940s, women working outside the home wore whatever protective garments their jobs required, including coveralls, smocks, or aprons. At home, they worked in full-length aprons with hefty pockets.

In the United States in the early 2000s, many people consider aprons 1950s kitsch, but aprons deserve more serious and thorough consideration than that. Many aprons are fine examples of textile craft; and most importantly, aprons are icons—symbols within popular culture. They conjure twin images: the mythology of motherhood and family in the cozy, homemade good old days; and the reality of the endless hard work those times required. Through a blend of individual and collective memory and fantasy, aprons have come to represent an idealized, apple-pie, June Cleaver-esque mom. Cartoonists adorn a stick figure with an apron to communicate that she’s a mom and probably a housewife. Though this character is a manufactured stereotype, she has held great sway as a role model—often wearing an apron.

The heyday of this archetypal housewife—and U.S. women’s aprons—was the post war era of the 1940s and



**Aprons on display.** Although the popularity of the apron has waned since the 1960s, they are still produced and worn, and can be both fun and functional, as illustrated by these whimsical gardening aprons. © ROBERT ERIC/CORBIS SYGMA. REPRODUCED BY PERMISSION.

1950s. Rosie the Riveter lost her well-paying job, and the media and government—thus the job market—encouraged her to be a housewife and mom. Sewing machines and cloth became available, and aprons—both commercial and homemade—became ubiquitous as the uniform of the professional housewife. Many 1950s aprons addressed housework and were decorated with sewing, cleaning, cooking, and “mom” themes.

This apron-wearing housewife served as family hostess and wore decorative serving aprons for holidays. She wore a more utilitarian model while in the kitchen getting things ready, but right before she entered the dining room, she donned her holiday froth. Commercial aprons were certainly available, but many holiday aprons were homemade. Not only were they made by the housewife herself, but they were also the stuff of church and neighborhood bazaars, often made of netting and festooned with ribbons, sequins, and felt. The at-the-ready hostess had at least one all-season party apron. In fact, if

possible, she had several to match her outfits. They were flashy and flirtatious and often sheer. Aprons were common hostess gifts, as well.

The postwar archetypal housewife was practical and creative. She made aprons out of remnants, extra kitchen curtains, dish towels, handkerchiefs, and flour sacks. When she made her aprons, she considered design as well as function. Many handmade aprons from the 1950s have one-of-a-kind designs and details.

The apron-wearing mom collected souvenir aprons—from maps of every state to “Indian aprons” that bore slight if any resemblance to authentic ethnic garb. At home, when she had “had enough,” she donned her letting-off-steam apron that said, “The hell with housework,” or the one that pictured a frazzled washerwoman and the caption, “Life can be beautiful.” And in the 1950s, when “the man of the house” was back from the war, he was supposed to spend weekends at home, so “men’s” aprons printed with barbecue and bartender themes became available.

By the early 1960s, the era of glorified housework was passing and with it the heyday of aprons. But aprons are still worn. At-home kitchen aprons have evolved into the unisex butcher/barbecue style. And aprons are filling a new at-work role as “the instant uniform.” An apron tied over any assortment of clothes produces a consistent look for a fast food chain or discount store. Generic aprons are shipped in from Central Supply and stamped with cor-

porate logos, and gone is the variety, the visual delight, and the individual expression that aprons once provided.

Aprons can reveal a lot about women’s lives. Examining a store-bought apron found at an estate sale or antique shop may yield information about the time from which the garment came and the woman who bought and wore it; and besides meriting study as a handcrafted one-of-a-kind item, a homemade apron may also contain clues about the life and times of the woman who made and wore it.

See also **Protective Clothing**.

#### BIBLIOGRAPHY

- Barber, Elizabeth Wayland. *Women’s Work. The First 20,000 Years, Women, Cloth, and Society in Early Times*. New York: W. W. Norton and Company, 1994.
- Cheney, Joyce. *Aprons: Icons of the American Home*. Philadelphia: Running Press, 2000.
- . *Aprons: A Celebration*. Philadelphia: Running Press, 2001.
- Florence, Judy. *Aprons of the Mid-Twentieth Century, To Serve and Protect*. Atglen, Pa.: Schiffer Books, 2002.
- McKissack, Patricia. *Ma Dear’s Aprons*. New York: Alfred A. Knopf, 1997.

Joyce Cheney



#### HOW OLD IS THAT APRON?

If a woman gives you the aprons she’s been saving all these years, talk with her about each one. When did she sew or acquire it? For what sorts of occasions did she wear it? For anonymous aprons, however, apron dating is both art and science.

Look through old magazines, catalogs, or patterns to find aprons like yours. Look at the apron’s shape. What dress style is the apron designed to cover? Once you’ve determined dress shape, look for pictures of vintage clothing to identify your apron’s decade. Check the fabric. How old is it? Study any decorations. What techniques and materials are used for embellishment and when were they in vogue? Note the colors. Colors pass in and out of fashion. If the fabric has a printed picture, check hairdos, clothes, appliances, furniture, or any other clues. If it’s a commercially made apron, check the label for clues.

**ARMANI, GIORGIO** Giorgio Armani, one of the most authoritative names in Italian ready-to-wear design, was born in Piacenza, Italy, in 1934. He became interested in fashion in 1957, when he left the school of medicine at the University of Piacenza to become a buyer for the La Rinascete chain in Milan. In 1964 Armani met Nino Cerruti, owner of Hitman, the Italian men’s clothing producer. After a brief period to see how Armani worked with materials, Cerruti asked him to restructure completely the company’s approach to clothing. Armani worked with Cerruti for six years, developing a simplified form of menswear that could be reproduced in series.

In the late 1960s Armani met Sergio Galeotti, which was the beginning of a relationship that lasted for years. In 1973 Galeotti persuaded him to open a design office in Milan, at 37 corso Venezia. This led to a period of extensive collaboration, during which Armani worked as a freelance designer for a number of fashion houses, including Allegri, Bagutta, Hilton, Sicons, Gibò, Montedoro, and Tendresse. The international press was quick to acknowledge Armani’s importance following the runway shows at the Sala Bianca in the Pitti Palace in Florence. The experience provided Armani with an opportunity to develop his own style in new ways. He was now ready to devote his energy to his own label, and in 1975 he founded Giorgio Armani Spa in Milan with his friend Galeotti. In October of that same year he presented his first collection of men’s ready-to-wear for



**Giorgio Armani with pieces from his collection.** After freelancing for a number of fashion houses, Armani founded his own label in 1976, quickly capitalizing on a reputation for producing high-quality, distinctive clothing at affordable prices. AP/WIDE WORLD PHOTOS. REPRODUCED BY PERMISSION.

spring and summer 1976 under his own name. He also produced a women's line for the same season.

### International Recognition

The secret of Armani's great success seems to derive from his having introduced, at the right moment, a new approach to clothing design that reflected the changes in post-1968 society, which was composed essentially of a middle class that could no longer afford to wear couture clothing but at the same time wanted to construct a distinctive image for itself. With this in mind, Armani established an innovative relationship with industry, characterized by the 1978 agreement with Gruppo finanziario Tessile (GFT), which made it possible to produce luxury ready-to-wear in a manufacturing environment under the attentive supervision of the company's designer. In 1979, after founding the Giorgio Armani Corporation, Armani began producing for the United States and in-

troduced the Mani line for men and women. The label became one of the leading names in international fashion with the introduction of several new product lines, including G. A. Le Collezioni, and Giorgio Armani Underwear and Swimwear, and Giorgio Armani Accessories.

In the early 1980s the company signed an important agreement with L'Oréal to create perfumes and introduced the Armani Junior, Armani Jeans, and Emporio Armani lines, followed in 1982 by the introduction of Emporio Underwear, Swimwear, and Accessories. A new store was opened in Milan for the Emporio line, followed by the first Giorgio Armani boutique. Armani's concern for the end user culminated in the development of a more youthful product with the same level of stylistic quality as his high-end line, but at a more accessible price.

Because of the democratic nature of the Emporio line, Armani felt that he had to make use of new and



unconventional advertising methods. These included television spots and enormous street ads, together with a house magazine that was sent out by mail to consumers, faithful Armani eaglet wearers. Armani also felt that a relationship with the cinema was essential, both for promotional reasons and for the stimulus to creativity. He designed the costumes for *American Gigolo*, directed by Paul Schrader (1980), the success of which led to a long-term collaboration with the world of film. Armani designed costumes for more than one hundred films, one of the most important of which was *The Untouchables*, directed by Brian De Palma and released in 1987.

In 1983 the designer modified his agreement with GFT. They began to produce both the Mani line for the United States and his high-end ready-to-wear line, rechristened Borgonuovo 21, after the address of the company's headquarters. During the late 1980s, despite Galeotti's death (1985), Armani continued to expand commercial horizons and licensing agreements. He opened Armani Japan and introduced a line of eyeglasses (1988), socks (1987), a gift collection (1989), and a new "basic" men's and women's line for America known as A/X Armani Exchange (1991). After the frenetic expansion of the 1990s (sportswear, eyeglasses, cosmetics, home, and new accessories collections), the year 2000, the twenty-fifth anniversary of the brand, saw a flurry of investment activity, including stock sales and the acquisition of new manufacturing capacity intended to increase Armani's control over the quality and distribution of his products.

### Style and Innovation

There is a common thread running through Armani's stylistic development that is closely associated with the change in contemporary society. It led to the creation of clothing and accessories that aimed at a clean, simple style, beyond fashion, designed to enhance the personality of the person who wore it. When, in 1976, the designer presented the first unstructured jackets for men, unlined and unironed, the product of years of experience in production design, they were intended to lower labor costs and simplify tailoring. But in introducing them Armani opened a third way in men's clothing, an alternative to the traditional approach of English tailoring and the expectations associated with Italian made-to-measure clothing, realizing an innovative synthesis between formal wear and loose, flexible sportswear. With the invention of the blazer worn as a pullover, Armani offered men a new identity that rejected rigid professional divisions and allowed them to present themselves as young, attractive, and vaguely feminine. Referred to as the "first postmodern designer," by several Italian newspapers, for his radically unstructured garments, Armani had simply softened men's wear and made women's wear more concise and modern, transforming changing social roles into an "Armani look," making the casual look authoritative.

Official recognition of his fame came in 1982 when he appeared on the cover of *Time* magazine, only the sec-

ond fashion designer, after Christian Dior, to do so. Armani had freed women from their stiff suits, providing them with soft jackets without collars and with comfortable pants. Although initially somewhat severe, as if intended to assist women in their climb to professional credibility, these outfits greatly enhanced a type of femininity that, because it was not ostentatious, was ultimately more real. Armani sought to establish an image of a woman who was strong but not harsh (a mix of the film stars Greta Garbo and Marlene Dietrich in modern dress) and who could be practical and indispensable as well as glamorous. Over time the jacket has continued to remain the centerpiece of the Armani wardrobe, changing year by year through the use of new materials, new proportions, and new colors. For Armani the "greige" (somewhere between gray and beige) of 1997 remained the most typical element in a palette often centered on shades of white and black, soft earth tones, dusty blues, and occasional unexpected bursts of color.

The search for fabrics has always been one of the distinctive elements of Armani's collections for men and women, becoming a key design element in 1986, together with embroidery and the return to evening wear that he brought about. Here the look was precious and exclusive but always in a minimalist key, demystified through the use of low-heeled shoes or sneakers. An attentive analyst of past cultures and Eastern influences, Armani's clothing has never been a collage of banal ideas. Throughout his career he has always succeeded in providing new images of how men and women dress and in translating elegant, decorative patterns into a unique but accessible style.

See also **Film and Fashion; Italian Fashion; Jacket; Ready-to-Wear; Sports Jacket.**

### BIBLIOGRAPHY

- Bianchino, Gloria, and Arturo Carlo Quintavalle. *Moda: Dalla fiaba al design italia 1951-1989*. Novara, Italy: De Agostini, 1989.
- Bucci, Ampelio. *Moda a Milano: Stile e impresa nella città che cambia*. Milan: Abitare Segesta, 2002.
- Celant, Germano, and Harold Koda, eds. *Giorgio Armani*. New York: Guggenheim Museum Publications, 2000.
- Sollazzo, Lucia. "Armani, Giorgio." In *Dizionario della moda*. Edited by Guido Vergani. Milan: Baldini and Castoldi, 1999.
- White, Nicola. *Giorgio Armani*. London: Carlton, 2000.

*Aurora Fiorentini*

**ARMOR** Accommodating and enclosing the human form, body armor has a direct connection with costume. Over the centuries, and in cultures worldwide, armor has been made from virtually all natural and many man-made media. During the Middle Ages and the Renaissance, armor was an effective defense and became one of the most



elaborate and complex bodily adornments. It both identified and concealed its wearer and made a definitive statement about personal fashion.

### The Earliest Armor

Humans' earliest supplemental protection was probably skins and hides. However, the earliest purpose-built defense, found in Europe and western Asia, was a type of belly plate made originally of organic material and later in bronze or metal-reinforced fabric. The Sumerians employed metal helmets and a metal-reinforced cloak. In about 2000 B.C.E. textile coverings appeared with applied, overlapping metal scales, which continued in occasional use until the eighteenth century.

A rather similar defense was lamellar armor. This probably first appeared in eighth century B.C.E. Assyria, composed of interconnected plaques or hoops, all worn over an undergarment. The Roman legionary's metal lorica *segmentata* is an example, as is the lacquered leather armor of Japanese samurai. The remarkable terra-cotta tomb figures of emperor Qin Shih Huang (221–210 B.C.E.) demonstrate China's use of lamellar armor for various troops identified by rank via color-coding and tassels. Mycenaean warriors during the Trojan War, and Greek hoplite infantry who fought the Persians wore body armor of layered linen. The Greeks and the inhabitants of the Italian peninsula also made use of bronze cuirasses (torso armor) embossed with musculature. All types were worn over an undergarment resembling period male ensembles.

Mail also appeared in classical times. Probably a Celtic innovation of the fifth or sixth century B.C.E., this network of riveted metal rings spread throughout Europe and into the East, and was widely used by the Romans and their allies. Mail's use steadily increased in Europe, particularly after the collapse of the Roman military system in the fifth century C.E., and among those who experienced its use by invading Hunnish cavalry.

### The Middle Ages

Leather and textile armor were used throughout the Middle Ages, and not surprisingly, their form and style conformed to prevailing civilian fashion. The most common metal armor in Europe until the thirteenth century was mail, the name derived from the French *maille*, or "mesh." Mail shirts, worn over a heavily padded undergarment, or *aketon*, eventually covered the thighs, and developed long sleeves with mittens. Mail hoods (*coifs*), leggings, a conical helmet or a barrel-shaped helm that covered all but the eyes, completed the defense. As extra protection against powerful weapons, a long, wooden shield was carried. Such warriors were expensive to maintain, and of great wealth—deriving this from lands given to them in return for military service. These armored men thus became the horse-mounted knights of popular imagination, and in many European languages, the words "knight" and "horseman" are identical. Each warrior was identified by a system of symbolism called heraldry. A



Those who wore armor recognized its importance and appreciated the expertise required in its manufacture. During a test-fitting of a new armor "his Majesty [Charles V] said that they [his armor parts] were more precious to him than a city . . . and they were so excellent that . . . if he [the armorer] had taken the measurement a thousand times they could not fit better" (Hayward, p.11).

knight's "coat of arms" appeared on his shield and, from the twelfth century, on a gownlike surcoat over his mail. The surcoat's length followed civilian fashion; some could actually trip up a warrior in combat.

However, better defenses were needed. By the early thirteenth century pieces of plate armor reappeared on a scale not seen since Classical Rome and became increasingly common on the torso and legs by mid to late century. Plate appeared in various forms—horn, bone, molded leather—but most often in iron. It offered rigidity and better resistance to weapons. It was shaped to the individual, thick where needed or thin to reduce weight, and its smooth, curving surfaces deflected weapons. It increasingly covered the body, although there seems to have been reluctance by some knights to be encased in rigid metal. Thus, there was a "transition" throughout the fourteenth century to mix mail and plate armor for the knight and his horse. This interim defense remained the primary form of protection in the armies of Islamic cultures and the Indian subcontinent until well into the nineteenth century.

Armor makers were divided into plate, mail, and textile (cloth armorers) specialists and tightly regulated. The transitional knight was a graceless, stout figure in layered textiles and iron, much of it cloth-covered. The plate edges had ribs to protect the armpits, elbows, and other



During the seventeenth century, a militia officer was struck by an arrow in the chest. His only defense was a hard piece of cheese inside his shirt. Almost unbelievably, the arrow hit the cheese. Informed of his subordinate's luck, his captain replied that this "may verify the old saying, *A little Armour would serve if a Man knew where to place it*" (Mason, p. 22).

vulnerable spots, with mail worn on the undergarment at these points.

By the beginning of the fifteenth century, the transition was complete. An individual wanting the latest in armor could have full plate—often without the textile covering, and with surfaces polished gleaming bright—virtually head to toe. The status of knights saw their clothing needs increasingly influencing male fashion, and vice versa. The change to all plate gradually produced a wasp-waisted appearance. This slim, hard-body look increasingly mirrored elegant male attire at the end of the century, and each complemented the other. For example, tubular arm defenses required slim sleeves on the undergarment, while shoulders broadened to accommodate extra padding for the load of a cuirass. Some armor elements were fastened to the aketon with laces called points. These also appeared on male apparel, to attach sleeves and hose. The aketon assimilated the new forms and was worn alone as knightly clothing. The surcoat became the short, form-fitting *jupon* (overgarment).

### The Renaissance and Armor's Decline

The fifteenth through seventeenth centuries saw both armor's acme and nadir. Plate armor remained paramount, changing with the demands of war, sport, and ceremony, and the continuing influence of civilian fashion. Centers in Italy (the term "milliner" originally meant a Milanese armor vendor) and Germany grew wealthy from the production and sale of armor. Master armorers throughout Europe crafted spectacular suits through the tailorlike handwork of specialists, including locksmiths (for hinges and fasteners), artists (Holbein and Dürer provided themes for armor decoration), and cloth armorers (the cloth tabs of internal linings were called *pickadils*, inspiring the name of the London district where makers were centered). The slim, angular, and rippled form of fifteenth-century German "Gothic" armor is regarded as the peak moment, in which pure form blended perfectly with function. However, in the early part of the sixteenth century, this gave way in some areas to the rounded, "Maximilian" style whose fluted cuirass imitated a globose doublet cinched by a waistbelt. The average weight was about forty to sixty well-distributed, balanced pounds in which a trained individual could do the same as in everyday clothing, especially mounting a horse unaided. Aketons became arming doublets and hose, an affair of durable material, padded with grasses, wool waste, or cotton especially at the load-bearing shoulders and hips, with points and garters to secure components. Some clothing, such as the kiltlike "base" skirt, gave texture and color to plain metal. Fashions again changed with the times, as once-pointed foot defenses (that imitated the *poulaine* shoe) became broadly rounded, then narrower and more contemporary. Breastplates followed doublet changes, also placing acid-etched decorative bands to imitate embroidery, and by the end of the century developing the grotesquely dipped "peascod" shape. Mail continued as a

secondary defense, or primary for the less wealthy. Textiles and plate combined in the vestlike brigandine used by all classes, differing only in the quality of materials and finish. The jack was similar, but generally of cruder stuff, and both defenses mimicked the doublet lines. A wide range of helmets was worn, from visored types that enclosed the head, to hatlike open forms. Foot soldiers favored the latter, and wore pieces of munitions-grade armor, sometimes little more than helmet and breastplate, or as much as a half armor to the hips.

Armor was also made for jousts and tournaments. Formerly training for war, these equestrian events became pure sport during the fifteenth century and required highly protective equipment that could reach 100 pounds. These suits have fueled the erroneous stereotype of the heavy, awkward knight, unable to mount without aid, and helpless if unhorsed.

From about the 1530s into the second half of the century, "Roman" and "antique" style armor became popular for festivals and spectacles. Other types of ceremonial armors flourished, even for children, as armorers experimented in fantastic creations, using a range of precious or fragile media to embellish the products of wealthy clients. Some were so extravagant as to be moving examples of decorative art or metal costume and were built by goldsmiths rather than armorers. Most armor was embellished to some degree. The entire decorative arts vocabulary was employed, including plating, enameling, encrusting with gems, but most often acid-etching.

The armorer's craft culminated in the garniture, a set of various components together with a basic armor and creating a versatile ensemble for war, sport, and ceremony. While each element had a designated function, it had to harmonize structurally and artistically with dozens of others. Such sets were extremely expensive and available only to very wealthy individuals.

Armor was also used by bodyguards, representing the patron's importance, good taste, and artistic refinement. Guard armor was sometimes limited to helmets, but embellished body armor was worn by those like the Vatican's papal guard.

Throughout much of the sixteenth century developments in firearms and changing battlefield tactics had an impact on armor's use. Powerful handguns required bulletproof armor that could weigh some eighty pounds, but retained its fashion relevance of its form. The lines of certain armor elements, such as the form of breastplates, tended to follow those of male civilian fashion. Complete head-to-toe armor became rare, with protection concentrated on the head and torso. By the seventeenth century, half or three-quarter armor (to the knees) became typical for horsemen, who now carried firearms themselves. Some troops wore "buff" leather coats, or padded textiles, and by the end of the century it was rare to see armor in war.

### The Enlightenment to the Present

Although most troops ceased wearing armor by the eighteenth century, military engineers (sappers) wore bullet-proof helmets during sieges, and some horsemen wore breastplates and helmets against sword cuts and firearms. The knight's neck defense, or gorget, became a symbol of officer's rank, and many armors became theatrical props. The Napoleonic wars briefly revived the use of some cavalry armor, but by the middle of the nineteenth century, its military use was again largely ceremonial. There were some exceptions, such as the breastplates privately acquired by both sides in the American Civil War (1861–1865), and Australian outlaw Ned Kelly's crude 100-pound body armor worn during a shootout. World Wars I and II revived interest in protective armor on a large scale. Allied and Axis physicians and scientists worked with curators to develop helmets and body defenses for ground troops and "flak jackets" for aircrew, but they used media and technologies little different from those of centuries earlier. Armor developments late in World War II and the Korean Conflict benefited from new plastic polymers. Soldiers' needs in Vietnam led to better armor, but it remained rather heavy and hot. The invention of Kevlar in the 1980s provided a material five times stronger than steel. Produced in fabriclike sheets, then laminated and encased in textiles, this has produced a new range of highly protective and light armor and helmets for the military, sport, law enforcement, and individuals. However, even more remarkable systems are under development in commercial and governmental laboratories, striving to produce another breakthrough technology, one just as dramatic as the suit of knightly plate armor that continues to fascinate us.

See also **Military Style; Protective Clothing; Techno-Textiles; Uniforms, Military.**

#### BIBLIOGRAPHY

- Blair, Claude. *European Armour*. New York: Crane, Russak, and Company, 1972; also published in 1958 by B. T. Batsford, Ltd., London. Remains the standard work.
- Blair, Claude, and Leonid Tarassuk, eds. *The Complete Encyclopedia of Arms and Weapons*. New York: Simon and Schuster, 1982. Best one-volume source of information on a range of arms and armor terms.
- Dean, Bashford. *Helmets and Body Armor in Modern Warfare*. Reprint of the 1920 edition, including the World War II Supplement. Tuckahoe, N.Y.: Carl J. Pugliese, 1977. Fascinating study of the development and use of personal armor in both World Wars.
- Edge, David, and John Paddock. *Arms and Armour of the Medieval Knight*. Greenwich Conn.: Crescent Books, 1988. Well-illustrated and accessible to a general audience.
- Ffoulkes, Charles. *The Armourer and His Craft*. Several printings available, the most recent by Dover Publications. Somewhat dated, but remains an important work on the topic.
- Hayward, J. F. "Filippo Orsoni, Designer, and Caremolo Modrone, Armourer, of Mantua." *Waffen und Kostümkunde*, 3rd ser., 24, no.1 (1982): 11.

- Mason, John. *A Brief History of the Pequot War*. Boston, 1736.
- Pfaffenbichler, Matthias. *The Armourers*. Toronto: University of Toronto Press, 1992. Well-illustrated and excellent resource.
- Pyhrr, Stuart W., and José-A. Godoy. *Heroic Armor of the Italian Renaissance*. New York: Metropolitan Museum of Art, 1998. Beautifully illustrated, premier study of Italian Renaissance parade armor.
- Robinson, H. Russell. *The Armour of Imperial Rome*. New York: Charles Scribner's Sons, 1975. Excellent, and accessible to the general reader.
- Snodgrass, A. M. *Arms and Armour of the Greeks*. Ithaca N.Y.: Cornell University Press, 1967. Scholarly and thorough.

Walter Karcheski Jr.

**ART AND FASHION** When one considers "fashion," as distinct from "clothing," "costume," or "dress," it is as a socially shared concept of what is to be worn at a particular point in time rather than an esoteric, ritualistic, or utilitarian cover or decoration of the body. The concept of fashion's point of origin in the mid-nineteenth century is contemporary with a fundamental change in the market for works of art. This was not accidental, since the institution of fashion, as clothing that adheres to particular modes of production, representation, and consumption, was connected to the emergence of similar structures in the creation and dissemination of works of art. Fashion came into being with the advent of the couture industry in Paris in the second half of the nineteenth century, when a bourgeois audience began to demand constant change as an intellectual, aesthetic, and, above all, economic stimulus for modern times. This is not to say that the notion of fashion did not exist previously. The timing qualifies the term as denoting clothing that is produced according to a certain seasonal rhythm, in quantities large enough to have an effect on sartorial appearances within a society, that can be exported as a "style," and that is consumed according to a prescribed agenda. Correspondingly, art as an autonomous production of subjective expression not bound directly to ecclesiastical or monarchist decrees emerged through the foundation of a bourgeois culture after the European revolutions between 1830 and 1848, when artistic education, independent structures of display, and expanded commercial possibilities allowed for a new creation and distribution of art. Thus, there exists a shared point of origin due to socioeconomic foundations in western Europe. Although fashion was produced elsewhere, too, it was this "Western" concept that eventually determined its global idiom and reception.

#### History I

The year 1868 saw "La Chambre syndicale de la confection de la couture pour dames et fillettes" establish the guidelines for the production and promotion of high fashion and the popularization of complex new fabrics



through weavers such as Joseph Marie Jacquard and through the development of the sewing machine by men such as Thimonnier Barthélemy. It was also the time when the art market expanded significantly due to technical advances in the reproduction of artworks, the establishment of museums such as le Louvre (which became property of the French state in 1848), and the opening of commercial galleries by the Durand-Ruels and Bernheim-Jeune (late 1850s, early 1860s) in the French capital. Therefore, art and fashion together began to leave the confines of private spaces and made the consumption of commodities public. Paintings were no longer exclusive to collections in haute bourgeois drawing rooms, and clothing was no longer individually commissioned from the comfort of one's own home. To view art and to buy gowns one had to venture out into the public, into a commercial setting. Contrary to the social and political impetus of the bourgeois toward increased privacy, the consumption of fashion in particular ran as part of a wide social current—being *à la mode* became a highly publicized statement in art as well as in clothing.

## History II

Art and fashion differ significantly in their respective attitudes to history. Art looks at its own historical tradition and, importantly, at the communication of history (historiography), as points of friction and contrast. History for artists consists of mythical or ideological narratives that can be illustrated, debated, and re-assessed in the context of artistic tradition. Styles or motifs are quoted, as in the historicism of academic painting, for example, but this process is consciously reflected upon. The costumes in European history paintings of the nineteenth century are often remodeled and redrawn to fit contemporary ideals of the past. Thus, for example, a subject wearing Roman toga is depicted with a contemporary hairstyle and contemporary makeup, and the face and body of the painterly subject follows modern perceptions rather than adhering to any archaeological evidence. The beholder of such artworks understands that historical authenticity is impossible but expects the painter or sculptor to communicate both the spirit of the past and its present interpretation. For fashion, too, authenticity is regarded as impossible; moreover, it is undesirable for the material impact of the design. Fashion's imperative, that is, its absolute contemporariness, has to be observed always. A costume for the stage might endeavor to evoke historical accuracy, but a piece of clothing created within the fashion industry has to transcend historical copy and be an absolute part of the present. In contrast to art, fashion is not expected to conform to ideals of reflection or visual truthfulness and integrity. Fashion is afforded a liberal view of history as a stylistic, pictorial sourcebook. The design of a dress or accessory can be a willful quotation that uses only one particular aspect of the history (such as the cut of a sleeve or waistline, or the setting for a jewel) while operating overall in a deliberately ahistor-

ical manner. In fashion the evocation of a historical period has to be immediate yet not necessarily correct in its aspects; visual impact and easy reading of the design take preference over historical accuracy in material or shape. History is filtered in fashion through the present; it is constantly updated and thus rewritten.

## Inspiration

These diverging attitudes to history within art and fashion are not simply due to material reasoning, although the dress in fashion, as opposed to costume design, has to exist in the contemporary market and can thus not be seen as only retrospective or pedantic in its historical detail. The purported seriousness of art in its relation to history and its Platonic equation of truth with beauty renders art the established basis from which fluctuating fashions can draw inspiration. Fashion uses art, analogous to history, as a visual model for its contemporary interpretation. The elevated position that is given to the fine arts in occidental culture is employed by fashion to raise the cultural capital of its creations. When fashion design displays an overt reference to a painterly style or motif, or quotes a particular artwork, the standing and value that the artist or work has accrued in the course of history is also transferred to the fashion design. This transferral occurs in a number of ways: (1) the artist becomes fashion (not costume) designer. One example is Giacomo Balla's menswear of 1914, which cites his own paintings; (2) the designer employs artists for the decoration of the garment, as when Salvador Dalí worked for Elsa Schiaparelli in 1937; (3) fashion renders a contemporary style in painting a decorative motif on the dress, as in Yves Saint Laurent's Pop Art collection of 1966; (4) the presentation of the collection becomes an art-historical *tableaux vivant*, such as Vivienne Westwood's catwalk of 1994, which cited the works of Franz-Xaver Winterhalter and other artists of the Second Empire; (5) the rendition of fashion in a magazine or other promotional media inserts the design into an art environment, as in Karl Lagerfeld's photos of 1997 that deliberately copy Bauhaus motifs. Conversely, fashion—in dress, accessories, makeup, and so forth—provides the source of inspiration for artists, especially in portraiture. The depiction of women in couture clothing on the canvases of Henri Matisse or Pablo Picasso, for example, show how the extravagant shapes or colors of the designer's creation guide the pictorial representation by the painter. Here, the new perception of the body that fashion can instigate through vibrant textiles, constricting or revealing fabrics, elongation of members through extravagant sleeves or extensions or forms through bustles and padded hips, for example, inspires the artist to take a new look at corporeal representation.

## Production I

Art and sartorial fashion have always shared terms to describe their procedure. Both the pictorial work of art as



well as the couture dress are traditionally sketched out, and both are then transferred from a paper template to canvas (the *toile*). And while the painting exists as the final outcome of the artist's vision, the *toile* in couture subsequently needs a further transposition into fabrics in order to appear finished. These procedural similarities do not exclusively define the character of modern painting or contemporary couture, but they go some way to explain why fashion designers have traditionally felt a strong kinship with painters and sculptors in regard to the making of their garments. In the nineteenth century haute couturiers saw themselves as artists in the development of their designs and their frames of reference (shown, for example, in the titles of dresses that allude to pieces of music, histories, allegories, motifs, or styles in painting), but also in subjective perception of the body, which in turn prompted the challenge to sexual mores. By the early 2000s this challenge had become less important than the recourse to and structural engagement with the traditional kinship of couturier and artist, evidenced when the Maison Martin Margiela proposed the paper template or *toile* to be worn as dress proper.

#### Avants-gardes

The parallels in the development of art and fashion in the *avants-gardes* of the nineteenth and twentieth centuries thus became visible through shared patterns and methods and styles of production, but also in adopting moral reflection, oppositional expressions, and attitudes toward commodification. At first the comparatively small group of couturiers and couturières of the second half of the 1800s, styled themselves along the established lines of artistic bohemians. From Charles Frederick Worth and Émile Pingat in the 1870s to John Redfern in the 1880s, they occupied studios and received clients in salons—thus echoing the environment for working and exhibiting in the fine arts (for example, the Parisian Salon as seasonal event). The furnishing of these rooms with collections of portrait paintings and assorted wall hangings indicate the cross-references and quotations that underscore the relationship between art and fashion.

While fashion used from the outset painterly tradition as a culturally established frame of reference and stylistic sourcebook, art looked to fashion for decorative solution in three dimensions and for structural inspiration in regard to repeatedly coined styles and the constant propagating of “originality” as a commodity. With the subjectivism and professed decadence of the *fin de siècle*, the profusion of decoration was shared between artworks and clothes; expressive hyperbole was *de rigueur* for both fields, as seen in fashion by Jacques Doucet or the Callot Sisters.

The turn of the century saw an emancipation of the body and simultaneously that of fashion's female clientele. More couturières established economic independence within the fashion industry (for instance, Jeanne Lanvin or Jeanne Paquin), and this was reflected in the

cultural climate on the whole. An emerging performativity in art (for example, opera and ballet became much more dynamic), and the sense of physical experimentation that pervaded performances by, for example, the Ballets Russes, combined with the abolition of the corset through the commercial adaptation of non-Western costume, freed the body for new movements outside socially prescribed spaces. This led to a rapid succession of art movements that proclaimed the breaking up of corporeality (cubism), its progression in space (futurism), or the construction of a communal body politic (constructivism, Bauhaus)—efforts that were structurally inspired by and became visually reflected in contemporary couture. Fashion presented the body as a fluid concept that could be determined through a sartorial shell, not as mere social agency but as an aesthetic concept. Madeleine Vionnet, for instance, demonstrated how dress shapes the proportion of the body, and Gabrielle Chanel showed how to liberate its posture.

With political mass movements in the years between the wars the uniformity of dress became significant. Politically committed artists used the unifying potential of clothes to demonstrate equality, and nonobjective painting provided, literally, a pattern book for the abstraction in cut and decoration, which dispensed with societal signifiers. Postwar artistic reflections of consumer society and the culture industry caused an ambivalent intimacy between art and fashion, as the former looked at the latter for the expression of codified consumption that was to be critically assessed, while the latter viewed painterly solutions, for example in Pop Art, as affirmation of its structural significance. The art market in the 1950s, 1960s, and 1970s coined in quick succession a series of artistic styles that resembled seasonal proclamation in couture.

With the creative expansion of ready-to-wear, the need for stylistic inspirations multiplied, and the past and recent history of art was increasingly required to serve as source material. Now, the concept of using the fashion industry not for its structural and procedural differences but employing its tropes directly for the production and representation of art has become widespread. Contemporary art cites fashion not just as an aesthetic model, but also as a field of reference in which the challenges and perils of modern life are glamorously played out. The engagement with fashion in contemporary art is also curatorial, that is, in displaying—often experimental—clothing in museums and galleries, pairing dress and art in exhibitions about material objects or notions of beauty, or using the fashion industry to fund art projects. The curatorial awareness of fashion leads in some cases to the institutional support of collections; for example, the first catwalks of the Dutch duo Viktor and Rolf were made possible only through the support and acquisition policies of the Centraal Museum in Utrecht and the Groninger Museum in Groningen. This implies the positioning of fashion in contemporary culture as one of many interchangeable manifestations, rather than as a

structurally distinct medium within a cultural hierarchy. The use of fashion's material basis (textiles, fabrics) and, significantly, its mode of representation through particular photographs, catwalk performances, and so forth, is used in contemporary art to play along with the late modernist staging of the culture industry.

### Production II

The production of couture adopted the idea of the independent, subjective artist and developed this stance despite the growing commercial pressure and industrialization of the industry's progress toward ready-to-wear. In the fashion industry there exists a pronounced dialectic that is expressed in the need for stylistic, some would say artistic, innovation that cannot be catered for by the manufacturing process that had given rise to couture as the basis for the fashion market established in the early twenty-first century. Designers perceive themselves as removed from the production process in auxiliary industries like weaving in a way that is similar to the painter who professes to be removed from the maker of the canvas or paper. Thus, from the birth of haute couture onward, fashion has had to accommodate the problem of relying on a design process that contradicts its procedural basis. This is the reason for the oscillating parameters of art and fashion and for the curious hovering of the latter around the former. The dialectic of fashion found in an individualized creation that exists within mass manufacture (which establishes its social coinage in the first place) was recognized willingly by the art market itself. The dialectic does not necessarily show itself in creation, although there has been, at least since Marcel Duchamp and Andy Warhol, a profusion of objects that covet a "designed" look and that are alienated from the artists through their handing over of the actual production to others (such as craftsmen, designers, studio assistants), but it is evidenced in representation, promotion, and consumption, in which fashion's principle is increasingly approximated by art in its advertising, gallery openings, growth of multiples, or museum shops, and in the fact that more and more foundations for contemporary art, as well as for music, architecture, and so forth, are now run by fashion companies, who thus embrace the cultural credibility that rests on the consumption of "high" art.

Within the realm of fashion it is at times difficult to separate neatly the production process from reception and consumption because the interrelation of the three segments constitutes its methodological core. Fashion is largely conceived through trend prediction and marketing analyses that attempt to anticipate as correctly as possible its manner and level of consumption. Correspondingly, fashion coverage, even outside identifiable promotional vehicles, reflects directly the interests of the designer or manufacturer. This, of course, appears as very different from artistic creation that might be influenced by demands from gallerists or commissions—increasingly

so in late modernism—but still asserts subjectivism to guarantee itself creative autonomy and institutional independence.

### Consumption I

The parallel consumption of art (in exhibitions) and fashion (in catwalk shows or shops) comes at the tail end of the change in modernity that moved from acquiring material goods for their functional purpose, through conspicuous consumption, in which objects are bought for their societal significance, to consuming the products as a spectacle, as entertainment within a saturated market. At the beginning art was consumed for "educational" purposes, to instruct the senses in what was understood to be morally just. It celebrated the dominant spirituality of the culture and favorably documented the established political system. Throughout the Enlightenment (as well as comparable tendencies outside occidental culture) the consumption of art began to operate along lines of individualized perception, and the communication of ideal beauty was understood to be based on temporal and spatial aspects and no longer as an unchangeable cogent. With the rise of a middle class that was socially mobile and less culturally dependent on one structure alone, art turned to the reflection and subsequent critique of its consumers. It no longer presented an unobtainable ideal of sentimental or spiritual perfection but introduced the vernacular, the popular, and the visceral into its discourse. The personal worldview of a particular consumer base took over from the universal understanding that had been propagated for the whole of a culture before. Western modernism challenged such particularity by looking again at quasi-scientific inquiries that should establish general principles for the aesthetic and social meaning of art. Yet such "empirical" principles were subject to change with every art movement that was usurping the one before and wiping the sociocultural slate clean for new individualized rules to be inscribed onto it. In the early 2000s, with the tropes of later modernism determining our understanding of art, its consumption has shifted from edification to entertainment.

### Consumption II

In contrast, the consumption of fashion originates in the pragmatic triumvirate of protection, modesty, and decoration. Clothes were first acquired for their utilitarian value, providing warmth, pious cover of the body, and adornment. The latter quickly became the ubiquitous signifier of consumption in which social status was shown through the splendor and profusion of fabrics and accessories. However, sartorial aspirations were still constricted by sumptuary laws and customs. No matter how much money the consumer might spend, certain colors or materials remained the proviso of nobility or clergy. In the eighteenth and nineteenth centuries consumption became increasingly conspicuous; that is, fashion was consumed as the most obvious sign of material wealth. More than carriages or town houses, sumptuous garments

acted as an immediate signpost of the social position that its wearer desired. Because fashion is a more direct but less expensive manifestation of wealth, compared with architecture or art collections, conspicuous consumption of clothes could be used by the nouveaux riches to present a façade of financial and social success that did not necessarily exist. Unlike art, the consumption of fashion is not based primarily on knowledge or education but functions through visual awareness, a type of sensuality and perception of the corporeal self. Obviously, couture, like fine art, was acquired originally by the most affluent parts of society, but fashion was still comparatively affordable for the aspiring middle classes, even if its constant change meant seasonal outlay rather than a one-off investment in a painting or sculpture.

Art can be consumed through beholding the object in a (more or less) public space without having to purchase it. The subsequent mental consumption, that is, its appreciation, possible interpretation, analysis or debate, occurs within the subjective personal domain. (This is apart from the art “professional”—artist, gallerist, critic, curator, for instance—who has to publicly communicate the result of such consumption.) In a reverse fashion, clothing is consumed by slipping on the dress or jacket and moving from personal confines, such as a changing room or bedroom, into a public space that is the shop, workplace, or social gathering. Modern media allows individuals to increasingly consume art in the privacy of their own homes. Concerts recorded on CD, films on DVD, and virtual museums on the Internet remove the necessity to withdraw from public space into one’s own imagination. However, the principle of moving from the public to the private in art, and conversely from the private to the public in fashion, still separates the two fields. To consume clothes conspicuously and to consume art self-effacingly show a divide between materialist objective and subjective contemplation. Here, fashion’s ontology marks it out as a public commodity, despite its very proximity to the individual, while the work of art ambiguously remains a more distant ideal (socially as well as physically) that is integrated into a wider cultural discourse and cannot readily be appropriated for personal consumption.

### Consumption III

Consumption in the culture industry habitually operated between the poles of ephemeral following of fashion and the establishment of permanent structures in art. The distinction between understanding an object as “consumable,” accepting its limited life span as characteristic, and the understanding object as a document or illustration of such consumption, separates fashion from art. When an object has become accepted *as fashion* it immediately ceases to exist. As sociologist Georg Simmel postulated at the beginning of the last century, fashion dies at the very moment it comes into being, in the instance when the cut of a dress or the shape of a coat is accepted into

the cultural mainstream. In order to guarantee its survival in commodity culture, fashion has to constantly reinvent itself and proclaim a new style that supplants the previous one. Modern art, in contrast, is seen to come into being only when its progressive shapes are canonized. Even in its most fugitive performance it always claims its right to lasting values—whereas clothes cannot mean to be permanent; otherwise parts of the textile and fashion industries would have to cease production. The dialectic (not binary pairing) of ephemerality and permanence shape the respective reception of modern art and modern fashion. Art has to remain mobile to reflect and interpret the ever-increasing speed of changes in modernity, yet it must appear permanent, lest it would be regarded as insubstantial. Fashion intends to be lasting—the greatest achievement of a designer is to create a “classic”—in order to be accepted as a substantial cultural fact, yet simultaneously needs to be ephemeral for immanent material as well as conceptual reasons.

See also **Caricature and Fashion; Music and Fashion.**

### BIBLIOGRAPHY

- Anna, Susanne, and Markus Heinzlmann, eds. *Untragbar*. Ostfildern-Ruit, Germany: HatjeCantz, 2001.
- Art/Fashion*. New York: Guggenheim Soho, 1997.
- Brandstätter, Christian. *Klimt and die Mode*. Vienna: Brandstätter, 1998.
- Celant, Germano, et al., eds. *Looking at Fashion*. Florence, Italy: Cantz/Skira, 1996.
- De Givry, Valérie. *Art et mode*. Paris: Editions du Regard, 1998.
- Evans, Caroline. *Fashion at the Edge*. New Haven, Conn.: Yale University Press, 2003.
- Fausch, Deborah, et al., eds. *Architecture: In Fashion*. Princeton, N.J.: Princeton University Press, 1994.
- Felshin, Nina, ed. *Empty Dress*. New York: Independent Curators Incorporated, 1993.
- . “Clothing as Subject.” *Art Journal* 1 (1995).
- Guillaume, Valérie, ed. *Europe 1910–1939*. Paris: Les Musées de la Ville de Paris, 1996.
- Hollander, Anne. *Seeing through Clothes*. New York: Penguin Group, 1980.
- Martin, Richard. *Fashion and Surrealism*. New York: Rizzoli, 1989.
- . *Cubism and Fashion*. New York: Abrams/Metropolitan Museum, 1998.
- Mode et art 1960–1990*. Brussels: Palais des Beaux-Arts, 1995.
- Müller, Florence. *L’Art et la mode*. Paris: Assouline, 1999.
- Ribeiro, Eileen. *Ingres in Fashion*. New Haven, Conn.: Yale University Press, 1999.
- . *The Gallery of Fashion*. Princeton, N.J.: Princeton University Press, 2000.
- Simon, Marie. *Fashion in Art: The Second Empire and Impressionism*. London: Zwemmer, 2003.
- Smulders, Caroline. *Sous le manteau*. Paris: Galerie Thaddeus Ropac, 1997.

- Smulders, Caroline, and Catherine Millet, eds. *Art et Mode. Art Press* 18 (1997).
- Steele, Valerie. *Paris Fashion*. New York: Oxford University Press, 1988.
- Steele, Valerie, and John S. Mayor. *China Chic*. New Haven, Conn.: Yale University Press, 1999.
- Stern, Radu. *Against Fashion*. Cambridge, Mass., and London: MIT Press, 2003.
- Troy, Nancy. *Couture Culture*. Cambridge, Mass., and London: MIT Press, 2003.
- Wollen, Peter, ed. *Addressing the Century*. London: South Bank, 1998.

Ulrich Lehmann

**ART NOUVEAU AND ART DECO** Art nouveau design penetrated into all types of modern, luxury European decorative arts in the period from 1895 to 1905. Its undulating vegetal curves and graceful floral swirls were also a design gift to the Parisian couturiers and until about 1908 or 1909 art nouveau style was energetically appropriated for seasonal, high-fashion use.

Evening garments were the most lavishly attuned to art nouveau. Couturiers swathed their evening wear with a profusion of silk brocade, appliqué, embroidery, and lace. From neckline to hem, the designers played art nouveau swirls around the voluptuousness of the fashionable figure, which itself was curvaceously shaped by “S”-bend corsets. Even tailored woolen walking costumes were trimmed with swirlings of appliqué. By 1907–1909, the style’s popularity had waned, replaced by a more upright figure styled with a geometric simplicity drawn from the Vienna Werkstätte, a fashion drawing from *Les Modes* of August 1909 by Gaby, *Toilettes pour Le Casino*.

### Historical Content

This appropriation of art nouveau styling coincided with the moment in the history of couture when a united business structure was firmly established by the *Chambre Syndicale de la Couture Parisienne*. Unrivaled elsewhere in the Western world, Paris couturiers dressed the women of international royal courts and high society including in Japan and tsarist Russia, the wives of the wealthiest international plutocrats, and the great actresses of the Paris stage. Commercial clients already included the grandest department stores at an international level.

The art nouveau “look” was at the cutting edge of modern style. Only the most fashionable wore it in its fullest manifestation, while others preferred moderated versions. These styles were spread internationally through fashion journals, such as *Les Modes* and down through middle-class oriented magazines such as *The Ladies Field* and *La Mode illustrée*. *Les Modes* of July 1902 featured, for example, an art nouveau ball dress by Maggy Rouff with full-length swirls in silver and diamante, on a straw-colored silk ground trimmed with alençon lace.

### Designers

From 1895 all the top twenty or so Paris salons were developing art nouveau fashions, from the House of Worth (whose designer was by then Jean-Philippe Worth) through the salons of Doucet, Maggy Rouff, Jeanne Paquin, and Laferriere to cite just a few. They launched season after season of art nouveau–styled garments on to the international fashion market. Examples survive in the great fashion collections of museums in Paris and the United States.

### High Art and Popular Versions

Within middle-class levels of ready-to-wear manufacture (for department stores and top levels of wholesale manufacturers), the style was watered down but clearly visible, as in a tailored woolen walking costume featured in *La Mode illustrée, journal de la famille* in January 1901 for example. The swirl did not, however, penetrate the cheapest levels of mass manufacture of tailored clothing for women. At the level of John Noble’s *Half Guinea Costume*, as seen in the *Lady’s Companion* of 19 September 1896, there was no trimming or decoration at all. Described as “dainty and durable,” consumers were concerned with little other than a vaguely stylish silhouette and issues of durability.

### Art Deco Fashion

Following the demise of art nouveau as fashion inspiration, the appropriation of art deco design by Paris couturiers informed the next fashion look. This had two phases. The first ran from about 1910 to 1924 and was built around neoclassical/oriental/peasant styling. The second ran from 1924 to about 1930—a more minimalist style, with modernist design touches



Paul Poiret led the first art deco fashion phase. His life was absorbed by orientalism, even as the Ballets Russes arrived in Paris, in 1909. He launched his slim, simple, high-waisted line in 1908, with its less-structured cut and delicately layered exotic style. Poiret was a collector of fauve paintings, which inspired his use of purples, pinks, blues, greens, and golds. Poiret's passion for orientalism, chinoiserie, European peasant, and North African design introduced a fresh bold simplicity to the cut and decoration. His 1911 *One Thousand and One Night Ball* set off a lasting vogue for the exotic, with use of light silks, gold tassels, turbans, tunic dresses, and bold use embroidery. Poiret unwillingly shared his limelight with other couturiers such as Jeanne Lanvin, Lucile, and the Callot Soeurs, who all created versions of the slender, high waisted and often sumptuous exotic look.

### Art Deco—Phase Two

From about 1924 Paris fashion crystalized into the hip-less *garçonne* look, reflected in the new sportive couture client, with her flat chest, bobbed hair, and less socially restricted lifestyle. The new generation of key designers included Jean Patou and Chanel, who both borrowed elements from Sonia Delaunay's far more extreme Orphic cubist designs. Madeleine Vionnet developed her skillful bias cut while Lelong produced the first ready-to-wear to come from a couture salon. These short-skirted, simple, art-deco garments were nevertheless always made from the finest wool or the most sophisticated gilded, flowered Lyon silks and embellished with complex beading or tucking to identify their couture provenance. Patou ended the look when he lowered the hemline in 1929.

### Fashion Illustration

A group of young struggling fauve artists produced a generation of fashion illustration of lasting quality and celebrity. Under the original inspiration of Paul Poiret, and his pochoir printed *Les Choses de Paul Poiret of 1909 and 1911* this period launched the careers of Barbier, Lepape, Iribe, Dufy, Erté, Marty, Benito, and Bonfils.

**Couture and popular versions.** The short skirt and dropped waistline were copied at all levels of the fashion trade, this time right down to the cheapest ready-to-wear, as seen in Sears and Roebuck and English ready-to-wear wholesalers' catalogs. Fashion knowledge and consumption opportunities were spread to a mass audience through the movies, through new cheap fashion journals, through home dressmaking, and through the wide availability of artificial silk or rayon (albeit still an unreliable fashion fabric). All of this accelerated the demand for mass, machine-made ready-to-wear and thus "up and coming" working-class girls on both sides of the Atlantic embraced moderated forms of art deco fashion even though their financial means were limited.



**Woman modeling Paul Poiret evening dress.** Poiret introduced art deco fashions to the world in the early 1900s, and several other prominent designers soon followed his lead. HULTON ARCHIVE/GETTY IMAGES. REPRODUCED BY PERMISSION.

### Retro Versions

While historical styling is never repeated in the same way, both art nouveau and art deco styles have been subject to fashion revivals. As the maxi hemline became accepted from the late 1960s, in Britain new psychedelic styles were linked to a subversive nostalgia for the imperial Edwardian period, for art nouveau, and for the work of Aubrey Beardsley. This is evident in the original art nouveau brand logo selected by Barbara Hulanicki for her fashion company Biba, founded in 1964. This is also clear in the art nouveau romanticism of her fashionable evening silhouette and use of feather boas, though she fused this with early 1930s style in her use of slinky satins and the bias cut. John Galliano presented several Edwardian-styled fashions in 1996–1997.

### Art Deco

Art deco design is far more deeply etched on the public mind as epitomizing a mythical ideal of free, youthful gaiety, glamour, and sexuality. This image has been strengthened by a stream of popular movies set in the 1920s, including *Singin' in the Rain* (1952), *Some Like It*

*Hot* (1959), and *Thoroughly Modern Millie* (1967), brought to the stage in New York in 2002 and in London in 2003. A filmed version of F. Scott Fitzgerald's *The Great Gatsby* in 1974, while the *Chicago* of 2002 and the Art Deco exhibition at the Victoria and Albert Museum of the same year, further escalated public fascination. The mid-1960s revival was led by Yves Saint Laurent with his African art deco collection in 1967, which perfectly suited that period's young, androgynous style. At the turn of the second millennium, Galliano reworked the flapper style in 1994, while Diane von Furstenberg showed flapper dresses with dropped waists and beaded fringing in New York on 17 September 2003.

See also **Appliqué; Doucet, Jacques; Galliano, John; Orientalism; Poiret, Paul; Saint Laurent, Yves.**

#### BIBLIOGRAPHY

- Benton, Charlotte, Tim Benton, and Gislaine Wood. *Art Deco, 1910–1939*. London: Victoria and Albert Museum, 2002.
- Charles-Roux, Edmonde. *Chanel and Her World*. New York: Vendome Press, 1981.
- Coleman, E. A. *The Opulent Era, the Work of Worth, Doucet and Pingat*. London and New York: Thames and Hudson, Inc., Brooklyn Museum, 1989.
- Greenhalgh Paul, ed. *Art Nouveau: 1890–1914*. London: Victoria and Albert Museum, 2000.
- Musée de la Mode et du Costume. *Paul Poiret et Nicole Groult: maîtres de la mode art deco*. Paris: Paris Musées, 1986.
- Troy, Nancy J. *Modernism and the Decorative Arts in France: Art Nouveau to Le Corbusier*. New Haven, Conn.: Yale University Press, 1991.
- . *Couture Culture, A Study in Modern Art and Fashion*. Cambridge, Mass.: Massachusetts Institute of Technology, 2002.
- White, Palmer. *Poiret*. London: Studio Vista, 1974.

Lou Taylor

**ASIA, CENTRAL: HISTORY OF DRESS** The styles of dress in Central Asia are as varied in appearance as are the ethnic origins of the people. Even in the early 2000s tribal groups living in remote valleys dress in a distinctive manner using their fabrics, their skills, and their accessories to accentuate their uniqueness.

The demarcation of territories with borders is a recent phenomenon in Central Asia. Earlier the people moved freely and intermingled. The nomadic peoples' yearly trek followed a designated path known as "The Way" and for special markets or meetings of different tribal groups they traveled across many territories. The land as a whole was known as Turkestan, and it was only under the Soviet regime that it was divided into Turkmenistan, Kazakhstan, Kyrgyzstan, Uzbekistan, and Tajikistan. Uzbekistan, which has the largest population, has a large number of Tajiks, Kazaks, and Turkomans who are citizens of the country. The Ferghana Valley

covers parts of Tajikistan and runs into Kyrgyzstan running right up to Osh and has a culture that is more akin to the Uzbek than the Kyrgyz traditions.

Despite the fact that the dress when seen worn by the people is distinctive, the basic structure of the main dress is very similar. This is perhaps true of all horse-riding nomadic cultures, qualities that molded the costume of the people of Central Asia. It is also interesting that the basic dress of men and women is also similar. A type of tunic or shirt, *kurta*, was worn by the men and women, with drawstring pantaloons, the *salwar*, which was very baggy at the top and tapered down to the cuffs, that were often decorated with embroidery or edged with woven tapes.

The tunic has a universal pattern. It is made of a narrow width of cotton or silk, which more or less matches the width of the shoulders and was folded over to cover the body, falling to about 4 inches (10 cm) from the ankles. A circular cut was made for the neck; the older pieces were open at the shoulders, while later ones had a cut from the center of the neck. The sleeves were also straight and sewn into the sides and the body piece, with the sleeve opening extending below the armpit. Diagonally cut pieces, narrow at the top and broader at the bottom, were attached to the side of the body of the tunic below the sleeves. They gave the shape to the tunic. The section joining the sleeve would have gussets attached between the sides and the sleeves giving a greater freedom of movement. A girdle, *futa*, or a length of cotton or silk either of one color, striped, or printed was worn wrapped around the waist, which supported the waist as men and women had an arduous life of walking through mountain areas often carrying heavy loads. Over this dress they wore an open coat, *chapan*, of cotton or silk material, which was either padded for winter or was plain, depending on the time of the year and the status of the user. The *khalat* was the more elaborate stylized silk coat of striped silk, cotton, or richly patterned *abr* (ikat) silk. These were invariably lined to preserve the cloth and the lining was often of hand-printed cotton material. Sheepskin coats embellished with embroidery were worn in winter.

Often men wore innumerable *khalat* one on top of the other to indicate their affluence. They began with the simplest at the bottom and worked their way up to the silk brocaded or velvet *khalat* given by the emir. Women normally wore an undershirt *munisak* and a tunic on top. In some cases women, too, wore more than one tunic and a shaped *chapan* on the top.

The dress worn next to the body was embellished at all the openings. This was not only for decoration, but also to protect the wearer. The neck carried elaborate embroidery around the collar and the sleeves as well as the side openings. The cuffs of the *salwar* were also embroidered or embellished with woven tapes, *zef*. These tapes were tablet woven and carried elaborate patterns. The finest were the tablet woven velvet tapes used for embellishing the *kabalats*.

The men's *chapans* or *khalats* were open in the front and had to be closed either with a shawl or with a leather belt with elaborate buckles. The belt was a sign of servitude and all the courtiers had to wear it when appearing before the emir.

The most elaborate part of the dress was the headdress. Men, women, and children used the headdress and they differed from region to region. By seeing the embroidery on the cap, the ethnic group and area could be identified. The most common were hand-stitched and embroidered skullcaps. Turbans were used by men and women. The bigger the turban the more important the person. Women in Kyrgyzstan wore elaborate turbans, which were decorated with silver and gold jewelry meant especially for the headdress.

Specialists wove the turban cloths, which could be of cotton or of silk. The indigo blue and white checks, *chashme bulbul*, the nightingale's eye pattern, was greatly appreciated. The skullcap worn by men was the base for the elaborate turban worn in public.

The most elaborate headdress was the one worn by young Kazak and Kyrgyzi women. The high conical hat, *Saukele*, was nearly 28 inches (70 cm) in height. It was made of felt, covered with velvet or silk and edged with fur along its rim. It was elaborately decorated with coral, turquoise, strings of pearls, and embellished with silver and gold pendants, as well as coins. The women of Karakalapak, a remote area near the Aral Sea, also used these headdresses, which were heirlooms and passed from one generation to the other. The use of such pointed caps is possibly an ancient tradition deriving from the clothing of the Scythian tribes of classical times, as it is linked with the famous Saka—*tigra kbanda* Saka, that is to say, Scythian with pointed caps.

The Turkoman married woman wore an elaborate headdress covered with silver and gold work and over that she wore a richly embroidered mantle, which came over her head and covered her body. The mantle has mock sleeves at the back.

The children were dressed with great care to protect them from evil influences and the evil eye. Silken shirts of children would be covered with amulets of silver as protective devices.

A study of different ethnic styles of Central Asian dress reveals the importance of accessories in creating a distinctive dress. A remark made by an Uzbek woman "everyone knows how to put on a dress, but not everyone knows how to carry it off" is a very true indicator of a well-dressed woman among these tribal peoples.

Though the traditions of dress in the area have ancient linkages, they are subject to change. The influences that lead to a change of fashion vary according to what is important within their own group. The changes in the past were less extreme and are more or less a case of variations on the same scheme. Records of travelers, which

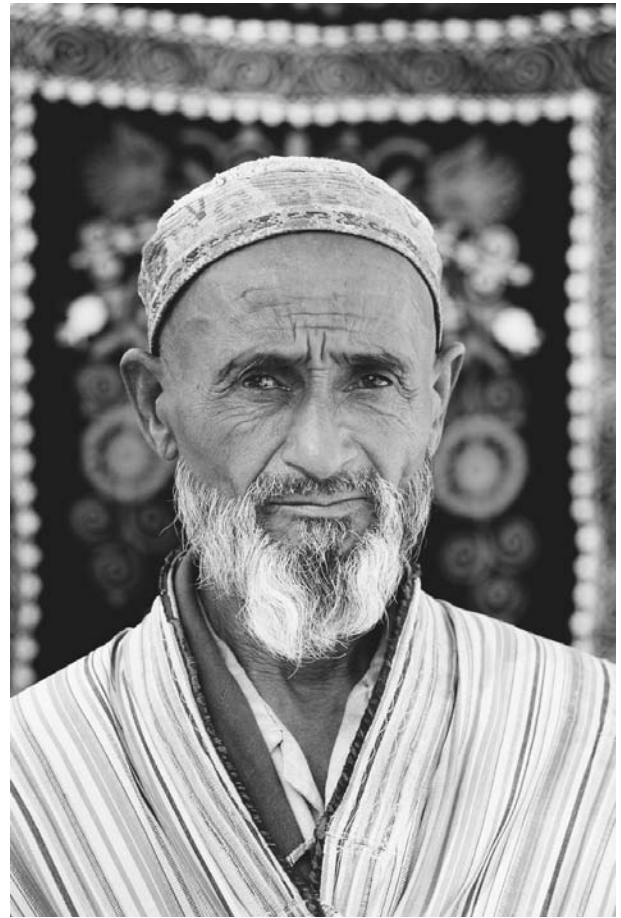

**Uzbek man.** In Uzbekistan, the traditional dress is the tunic-like *kurta*, often covered by a *pheran*, a long, loose, coat-like garment. An embroidered cap was also worn when leaving the house. © KEREN SU/CORBIS. REPRODUCED BY PERMISSION.

give descriptions of the dress of the people over the last couple of hundred years, indicate the changing fashions. The Soviet influence, especially in the urban areas, did introduce changes in style, but in the rural areas and among the older persons the style of dress remains to a great extent unchanged.

### Uzbekistan

The basic dress of the men and women was the *kurta* and the *salwar*, but over that they wore a full *pheran*, generally made of *atlas*, a woven silk, satin, or the mixed cotton and silk cloth commonly used by the women. For special occasions they would wear a shirt of *abr*, the brilliantly colored ikat weave. These would be embroidered around the collar and the sleeves, as well as on the edges or edged with tablet woven tapes. A coat was worn when receiving visitors or if stepping out of the house and the head would be covered with an embroidered cap and a large shawl. The coat and even the overshirt would be padded for winter and the coat would be lined with





**Kazak horseman.** Basic dress for Central Asian nomadic cultures consists of a *kurta*, *salwar* (drawstring pants), and an overcoat, either a cotton *chapan* or the more elaborate silk *khalat*.  
© NEVADA WIER/CORBIS. REPRODUCED BY PERMISSION.

printed cotton and edged with silk. They also had the custom of wearing embroidered oversleeves, *ton janksh*, which were separate from the *kurta* and were taken off when washing the main garment. Over this an embroidered mantle, *kok koilek*, with mock sleeves was worn over the head. This was an essential part of their dress outside the home; the older women wore white while the young married women would wear a red mantle.

The *salwar* was also richly embroidered at the cuffs and peeped from below the *kurta*. Different types of scarves and shawls were used for wrapping around the waist. The headscarves would be either embroidered wool or the gossamer floating resist-printed silks of Bokhara.

Young brides wore elaborately embroidered clothes and they also wore an elaborately woven and decorated veil over the face. The dress of the bride was often blue and richly covered, as well as embellished with jeweled plaques. The area of Karakalpak, which is near the Aral Sea and quite remote, has very fine embroidered dresses and accessories as cover for the head and the nape of the neck, which was considered very vulnerable.

Bokhara was the main center for gold embroidery, which was prepared with a technique called couching to create a rich, raised effect. Couching is an embroidery technique in which threads are laid in a design on the surface of a base fabric and sewn to the fabric with small stitches that cross over the design threads. These outer robes were worn by women for special occasions, as well as by the men as *khillats* given to them by the emir.

It was a tradition for the emir to present a full “head to foot” set of clothes to the male head of a family who was employed by the emir or was a member of the court.

Men’s dress was the *kurta*, *salwar*, with a cummerbund, a sash. Over this he wore a robe open in the front, which was held together either by a woven sash or a belt. Skullcaps were an essential part of Uzbek national dress and came in a range of shapes and sizes. Some are conical and formed the base of the turban; others may be four sided, round, or cupola-shaped. All the caps were embroidered whether it was the simple gray or black cap with white embroidery or rich multicolored embroideries. Until recently the cap would identify the ethnicity and the region of the wearer. For the young brides elaborate gold embroidered caps with tassels were specially made.

### Turkmenistan

The Turkoman nomadic group came from the Altai Mountains. Their ancestors were the Oghuz and their traditions have been preserved in the “Book of Oghuz, *Oguz Nama*. Around the tenth century they were settled in the region east and south of the Aral Sea, when they came to be known as Turkoman. In the fifteenth century there were two confederations: *Qara-Qoyunlu*, “they of the black sheep”, and *Aq-Qoyunlu*, “they of the white sheep”. A number of the leaders entered Iran as shepherds and conquered it to remain as rulers; however, a large number of them remained in the area and evolved their own way of life with their swift horses, which were their pride and their lifeline; and their sheep, camels, and other cattle with which they migrated according to a seasonal cycle of available pastureland and water. However, their movement was not very far and it was confined to approximately within the radius of 31 miles (50 km). The round, felt-covered dwellings called *Oy*, yurts, were an essential part of the Turkoman way of life, and even the agricultural groups moved to the summer camps and lived in the yurts.

The Turkoman’s women’s costume is similar to the tunic. It is made out of silk because there is no prohibition to wearing that material. The silk is of narrow width because of the loom and is generally woven in red with a yellow stripe near the selvage. By joining the side panels and retaining the yellow line, a very well defined linear quality emerges in the garment. Ordinarily women in everyday life wear a tunic with an opening up to the breasts, held together with a silver button at the neck. For special occasions they wear an inner tunic that is em-



broidered at the edges. The embroidery stitches are limited, however, as they are a number of variations of looped stitches and create a rich texture. The main stitch is similar to the feather stitch. The chain stitch, *svyme*, is used by the Yomut, along with the stem stitch. The joining of two pieces in a dress is done with a raised decorative herringbone. Extra-embroidered sleeves are also worn. Over that they wear a jacket with short sleeves, *chabut*, which is covered with coins or silver plaques, which end with elaborate silver pendants. They also wear a long coat among some of the tribes, which had become common in the beginning of the twentieth century. The coat was held together with a checkered sash, which hangs in the front and is known as *sal qusak*. Silver belts may be used, but only rarely.

Turkoman women have an elaborate high cap, which has a base of a basketlike form made from coiled and stitched local grass and covered with silk. It is then decorated with silver coins, plaques, and chains and over that is worn a scarf, which is secured by chains studded with flat carnelian. On top of all this they drape the most dazzling piece of embroidery—a mantle with the *chyppy*, carrying mock sleeves. The colors vary according to the age of the wearer. Young women wear blue or black, the middle-aged ones yellow, while the matriarch wears white.

Another simpler headdress composed of a long, folded scarf, *aldani*, is used along with a skullcap, which was worn like a turban with its ends hanging to the left shoulder. Often one edge of the scarf is kept loose to be used for veiling the face.

The pantaloons, *salwar*, have heavily embroidered cuffs worked in striped thick silk material. The baggy top is made from ordinary cloth to which the cuffs are attached. Only the embroidered part is visible from beneath the shirt. The pantaloons are tied at the hip.

The men wore silk tunics, which opened on the side. A woven sash was worn around the waist and a *salwar* tight at the base and loose above. Woolen puttees with decorated edges covered their legs from the ankle up to the calf and long leather boots were worn. They wore sheepskin jackets or long coats with the fleece inside, which were extremely warm. The fleece shows at the edges. The finest coat is that made of unweaned lambs having a curly fleece nearly 4 inches (10 cms) long. The shepherds used to wear a felted coat, *yapunca*, which protected them from the cold and from rain and snow. The most characteristic element is their bushy hat with a long fleece, which extended over the forehead and sheltered the eyes from the glare, as well as from snow and rain. The *abr* silk *khalat* was also used for celebrations. Mostly, these have remained in the family chests as heirlooms and hardly ever worn.

### Kyrgyzstan

Kyrgyzstan is a mountainous country surrounded by deserts. The Tien Shan (“Heavenly Mountains”) range

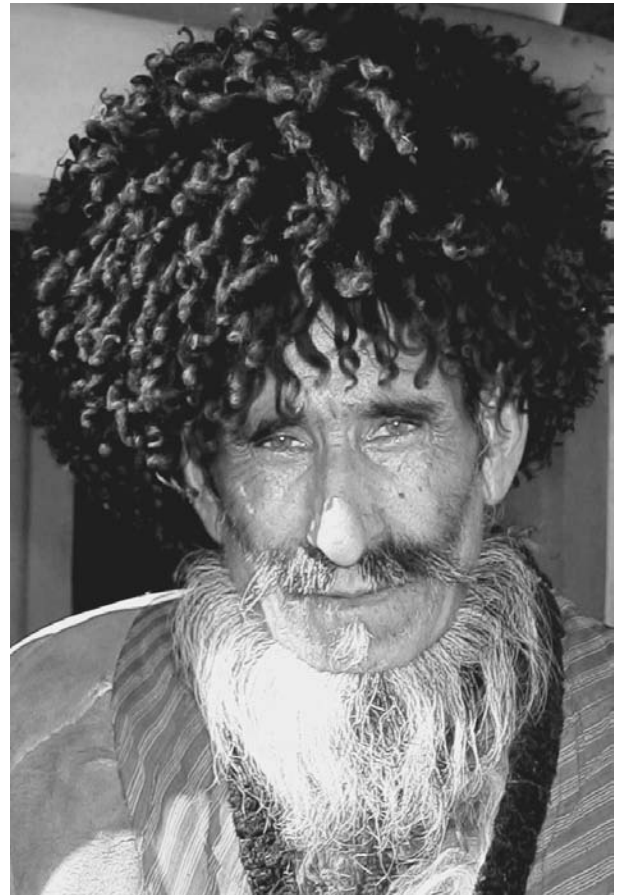

**Man in Turkmenistan.** The most distinctive item of clothing for the Turkman is a large hat made of drooping fleece, which serves to protect the face from the elements. © WAYMAN RICHARD/CORBIS. REPRODUCED BY PERMISSION.

separates it from the Ferghana Valley, part of which occupies the southwestern area of the country. The Kyrgyz’s rich cultural traditions are seen in the mountainous areas of the northern part of the country, where they settled as they moved from the Altai Mountains in southern Siberia. The Chinese chronicles describe them as fair skinned, green eyed, and red haired. The Mongols arrived in the tenth century and the intermingling created a very sturdy, handsome people, whom even the Soviets could never change.

The Kyrgyz have traditionally been a nomadic people, living in yurts. Even in the early 2000s many Kyrgyz have a yurt in their compound, and the death ceremony even in the capital city, Bishkek, is performed in a yurt. Their 100-year-old epic *Manas* tells the story of the warrior king and the migrations, of his people. It is the world’s longest epic and the *Manaschi*, who recite the story, keep the oral tradition alive.

The traditional dress worn by the men is often leather trousers, *terishym*, which are also used by women

when they are migrating or helping with the animals. These are worn along with high leather boots for everyday, *chaitik*, or embroidered *massey*. Over that they wear a shirt and often a leather jacket with fur lining known as *ton*. For special occasions the older men wear a long coat, *chepken*, which may be held together by a sash or a leather belt with silver buckles, *kur*. Very fine suede long coats with extra-long sleeves were made with elaborate hook embroidery. The typical headgear is a conical embroidered felt cap with embroidery and a tassel at the top, *ak-kalpak*. For special occasions the urban men wore flat, gold embroidered caps with fur lining and fur edging the headdress.

The women wore a long shirt, which was often made out of striped red and black cotton known as *kalami* or it could be of *abr*, the ikat of cotton and silk. For everyday use they would wear a sleeveless jacket and a padded long coat along with leather shoes. They wore a bonnet with embroidered ear caps over which a turban would be worn or a decorated cap. Long, embroidered plait covers were worn to cover the nape of the neck, which was considered to be vulnerable to black magic. The women favored greatly the brightly colored ikat striped cotton of Kodzhent, which was given a glossy polished surface with the use of egg white. This was used as a sash, as well as a scarf. Elaborate dresses, *koinok*, were made from silken patterned cloth known as *kimkap*, probably derived from the name for woven gold brocade of India, the *kimkhab*. For special occasions they wore a wraparound skirt, *belde-mebi*. It was either made of velvet or silk with leather and fur lining, and rich embroidery. This could be worn easily on horseback and would cover them well, giving warmth as they rode their horses.

The *bishmant* was the elaborate dress worn by brides along with a long, conical headdress decorated with gold, silver, pearls, and precious stones and often with a highly decorative veil to cover only the front of the face, while a gossamer colorful veil floated beyond from the conical hat. Older women wore elaborate turbans made of fine cotton, *chosa*. The turban was held in place by an embroidered strap. From beneath the turban, a draped cloth covered the neck and the front of the neck giving great dignity to the matriarch. On special occasions even in the early 2000s one can see in the mountain villages the older married woman astride a horse with her elaborate dress and headdress, riding forth to accompany the men, who are dressed in their finest embroidered leather coats and caps and who carry hooded hawks on their wrists.

Jewelry is very much a part of the dress. Elaborate buttons were used on the dresses. Long silver and coral earrings, *iymek*, which extended nearly 9 inches in length, framed the face. Large pendants were worn on the breasts as protective shields and linked chains of pendants and corals were stitched to the jackets. Silver buckles were attached to the leather coats and belts of the men. The engraved symbols of the sun, the moon, the stars, the falcon (their totemic bird) and others, protected them from the

evil eye. The magical skill of the silversmith associated with fire and molten metal imbued the wearer with strength to face the adversities of life.

See also **Cotton; Jewelry; Silk; Textiles, Central Asian; Traditional Dress.**

#### BIBLIOGRAPHY

- Beresneva, L. *The Decorative and Applied Art of Turkmenia*. Leningrad: Aurora Art Publishers, 1976.
- Burkett, Mary. *The Art of the Felt Maker*. Kendal, U.K.: Albert Hall Art Gallery, 1979.
- Gafiar, Gulyam. *Folk Art of Uzbekistan*. Tashkent, Uzbekistan: Literature and Art Publishing House, 1979.
- Geiger, Agnes. *A History of Textile Art*. London: Maney Publishing, 1979.
- Harvery Janet. *Traditional Textiles of Central Asia*. London: Thames and Hudson, Inc., 1977.
- Sidenvagen, Vid. *On the Silk Road*. Göteborg, Sweden: Historiska Museum, 1986.
- Sumner, Christina, and Heleanor Fellham. *Beyond the Silk Road*. Sydney, Australia: Arts of Central Asia; Power House Publishing, 1999.

*Jasleen Dhamija*

**ASIA, EAST: HISTORY OF DRESS** East Asia includes the present countries of China, Korea, Japan, and Vietnam (the latter also can be considered part of Southeast Asia), along with adjacent areas of Inner Asia that have historically sometimes been part of the Chinese empire and often have been heavily culturally influenced by China. These regions include Manchuria (now the three northeastern provinces of China); Mongolia (including the Inner Mongolian Autonomous Region of China and the independent Republic of Mongolia); East Turkestan (now the Chinese province of Xinjiang); and Tibet (now the Tibet Autonomous Region of Chhia, plus adjacent areas of the provinces of Qinghai, Sichuan, and Yunnan).

China was historically the dominant presence in East Asia, by virtue of size, population, and wealth; China regarded itself as the center of the world, the fountainhead of culture, and a beacon of civilization to surrounding peoples. Surrounding peoples did not necessarily share that assessment, but they could not avoid, and often did not wish to avoid, the influence of Chinese culture. The importance of silk in the history of East Asian dress is both evidence and metaphor for China's cultural domination of the region.

Silk, produced in parts of China since at least the third millennium B.C.E., was the favored textile material of China's elite thereafter (commoners wore hempen cloth in ancient times, cotton increasingly after about 1200 C.E.). Both the technology of silk production and the cultural preference for wearing silk were exported from China to Korea, Japan, and Vietnam in the early centuries C.E. Silk cloth (but not, except by accident or

industrial espionage, silk technology) was exported regularly and in large quantities from China to Central and Western Asia along the Silk Route beginning in the first century B.C.E.

The cultural frontier is a very old one. Around 1000 B.C.E., near the Tarim Basin in East Turkestan (now Xinjiang Province, China), the easternmost representatives of the Celtic people were weaving woolen twill cloth in plaid patterns indistinguishable from those made by Celts in Europe at the same time. A thousand miles to the east, the kings of China's Western Zhou Dynasty (1046–781 B.C.E.), in their capital city near present-day Xi'an, clothed themselves in richly patterned silks woven in royal workshops. The border between the Chinese culture and the Inner Asian culture areas may thus be thought of as the border between silk and wool, with Chinese silk serving to create trade connections between the two cultures.

### China

The basic garment of China, for both sexes, was a robe-like or tunic-like wrapped garment. Elites wore robes, preferably of silk, that were wrapped around the body and tied closed with a waist sash. Such robes were either long enough to require no lower garments or somewhat shorter (e.g. thigh length) and worn over trousers or a skirt. Trousers and skirts were not closely tied to gender and were worn by both men and women. Both sexes considered it socially essential to wear their hair bound up in a topknot or other dressed style, and covered with a head cloth or hat of some kind. Elite women favored highly colorful patterned silk cloth for their clothing. Fashion in women's clothing went through an era of rapid change during the Tang Dynasty (618–907), when a wealthy and cosmopolitan imperial culture stimulated consumption and emulation, and novelty was supplied by cultural influences, via the Silk Route, of Persian and Turkic peoples.

Elite men's clothing in ancient times was also often quite colorful, but men's clothing tended to become more somber and plain-colored in later periods. This trend toward plainer clothing was offset, however, by the development, from the late Song Dynasty (twelfth century) onward, of the "dragon robe" for use as court dress.

Commoners generally wore short robes or jackets over trousers or leggings; women sometimes wore skirts, and men sometimes wore only a loincloth as a lower garment, particularly when doing heavy agricultural work. Cavalry became an important part of the Chinese military from the late first millennium B.C.E. onward, and cavalymen typically wore short wrapped jackets or short robes over trousers.

The dragon robes of late imperial China conveyed, through color and design details, precise information about the rank of those who wore them. Similar information for lower-ranking officials was conveyed through



**A Japanese woman in a kimono, ca. 1880.** The T-shaped garments are often produced with richly embroidered fabrics. Following World War II, kimonos were usually worn only on special occasions. JOHN S. MAJOR. REPRODUCED BY PERMISSION.

Mandarin squares, embroidered cloth badges that showed a wearer's civil service rank and were worn on the front and back of official robes.

Chinese dress changed radically after the end of the imperial period in 1911. A new form of men's clothing, called the Sun Yat-sen suit, developed on the basis of European military uniforms and won widespread acceptance; this suit had a jacket with a high, stiff "mandarin" collar, four pockets, and a buttoned front, with trousers in matching cloth. A new women's dress, called the *qipao* or *cheongsam*, evolved in Shanghai and other Chinese cities in the 1920s and 1930s; it was based on a restyling of the Manchu long gown of China's last imperial era, the ethnically Manchu Qing Dynasty. After the Communist revolution of 1949, the Sun Yat-sen suit evolved into the ubiquitous blue cotton Mao suit worn by both sexes; the *qipao* fell into disfavor in Communist China. It has since had a modest revival as formal wear. In general, however, traditional dress has disappeared in China, except among China's ethnic minorities, some of whom retain traditional or quasi-traditional dress styles as markers of ethnic identity.



Many “national minority” groups exist in China, the majority of them concentrated in the southern and southwestern provinces of Guangxi, Guizhou, and Yunnan. Important minority groups include the Zhuang, Miao, Yao, and Dai, among many others. Some are ethnolinguistically akin to Austronesian-speaking populations of Southeast Asia, such as the Shan of Burma (Myanmar) and the Hmong of Vietnam and Laos. The dress of these minority peoples varies widely, but often (as in the case of the Miao) features black-dyed cotton tunics worn with skirts or trousers and ornamented with colorful embroidery and sewn-on silver coins or beads. Women of the Dai minority wear fitted blouses with wrapped skirts similar to the *lungyi* (sarongs) commonly worn by Burmese women.

### Vietnam

Historically, Vietnam can be divided into three regions: from north to south, Tonkin, Annam, and Cochin China. The northern and central regions were strongly influenced by Chinese culture while vigorously resisting Chinese conquest or political domination over the course of many centuries. Elite dress for both sexes was based on Chinese models, with males of the ruling class wearing plain long robes for ordinary wear and dragon robes or robes with Mandarin squares for official use. Women’s dress strongly reflected Chinese women’s fashionable attire. Working people of both sexes wore dark, wrapped jackets with skirts for women or short trousers for either sex—the “black pajamas” of Vietnam peasants that became an iconic image for Americans during the Vietnam War.

Culturally, southern Vietnam—Cochin China—was more closely related to Southeast Asia, and especially Cambodia, than to China. That was reflected in local dress, which featured wrapped skirts (sarongs) for both men and women, with wrapped upper garments for women and light, shirtlike jackets (or no upper garment) for men.

Under French colonial rule, from the 1860s to the 1950s, some elite men wore variant or hybrid forms of European dress, and some women of the same classes wore fashionable Western dress. Partly in response to this Westernization of Vietnamese dress, a new women’s ensemble, the *ao dai*, evolved in the early twentieth century. It features a blouse worn above loose silk trousers, the whole outfit topped with a long, loose tunic open to the hip at each side. Though a recent innovation, the *ao dai* was accepted as a “traditional” and national dress by the mid-twentieth century and had retained that role.

### Korea

Korean national dress for both men and women is known as *hanbok*, which simply means “Korean robe.” The traditional men’s ensemble, which is related to clothing of Manchuria and the steppe lands beyond but has no close connections to Chinese men’s clothing, consists of a

wrapped short jacket worn over voluminously baggy trousers tucked into black felt boots, the whole outfit topped with a stiff silk gauze coat in some light color, such as pale green or pale blue. A stiff black horsehair or straw hat completes the outfit.

The woman’s *hanbok*, in contrast, is probably derived from a Tang Dynasty women’s fashion for high-waisted dresses worn with a short jacket (or from a later Chinese revival of that Tang style). It consists of a skirt or very wide trousers worn with a long-sleeved wrapped top tied with a ribbon just below the bustline, the whole outfit covered with a silk gauze overskirt. The woman’s *hanbok* has undergone numerous changes in style over the course of time. A simplified version has been revived in Korea as a form of national dress that is considered beautiful, patriotic, and feminine.

### Japan

Japan began to be influenced strongly by continental culture from Korea, and from China via Korea, by the end of the third century C.E., and increasingly with the introduction of Buddhism in the mid-sixth century. Soon domestically produced silk fabric competed with imported Chinese and Korean textiles, though the latter retained high prestige value. In the aristocratic culture of the Nara (710–785) and Heian (795–1185) periods, fashion was thoroughly assimilated to Japanese cultural norms and was expressed in details such as color, cut, and decorative motifs in clothing that retained always the basic theme of the wrapped long robe. Men wore long robes of patterned silk or, for riding and other activities, shorter wrapped jackets over wide, baggy trousers of matching or contrasting material. Women of that era wore multiple layers of wrapped robes, cut so as to reveal each layer beneath the last; the tasteful blending of colors of such layered ensembles was an admired feminine accomplishment.

During the era of rule by a warrior aristocracy (samurai) that began in 1185 and lasted for nearly 700 years, clothing for both men and women evolved toward the T-shaped wrapped garment known as the *kimono*, in which elements of taste were expressed more in textile elements than by the cut or style of the garment itself. Fashion and style found expression in dyed, woven, or embroidered fabrics of sumptuous quality and fantastic variety; the wearing of an embroidered family crest at the nape of the neck by families with the right to do so; the choice of fabric and tying technique of the wide *obi* sash used to fasten a woman’s kimono, and so on. Kimonos were displaced for most purposes by ordinary western-style clothing in the post-World War II period, and afterward were largely worn only as formal wear and on special occasions.

Clothing of working-class Japanese in premodern times was made of hempen cloth or, from about the sixteenth century onward, of cotton, usually indigo-dyed using techniques that are now much admired by connoisseurs of folk textiles. Traditional working-class garb survives



in some rural Japanese communities as a somewhat self-conscious expression of conservative values.

### Inner Asia

The three northeastern provinces of China that formerly made up Manchuria, barely retain a separate ethnic tradition, and there are only a few thousand remaining native speakers of Manchu. Traditional clothing has largely disappeared.

Mongolia, in contrast, retains a vigorous national culture, both in the independent Republic of Mongolia and in the ethnically Mongol region of the Chinese Inner Mongolian Autonomous Region. The national dress of Mongolia for both sexes, called the *deel*, is a wrapped robe, preferably of colorfully patterned silk (imported from China), closed with a long sash at the waist, worn over trousers for riding, and sometimes worn with a silk sleeveless vest. For cold-weather wear the *deel* is padded with cotton or silk floss and sometimes lined with fur. In all seasons it is worn with heavy leather boots. Mongol women traditionally wore extremely elaborate head-dresses set with silver ornaments, in styles that were identified with particular tribes and clans. Men, too, wore hats distinctive of clan affiliation, and the hat played a singular role as the repository of male honor; to knock off or even to touch a man's hat without permission was to invite violent retaliation.

An unusual and distinctive item of Mongolian dress is the costume worn by men for wrestling—one of the “three manly sports” (along with riding and archery) of Mongol tradition. It consists of very tight short shorts, ordinary heavy Mongolian leather boots, and a tight-fitting, vestlike top that covers the shoulders, upper back, and upper arms, but leaves the chest bare.

In East Turkestan (now Xinjiang Province, China), the non-Chinese indigenous population consists largely of Uighurs and Kazakhs, both Turkic peoples ethnically akin to other Turkic peoples of Central Asia. Traditional dress varied widely among specific groups but tended toward wrapped, coatlike outer garments worn over a shirt and trousers, for men; and blouses, voluminous skirts, and long vests for women. Many men of the region wear the small, round, embroidered caps found widely among Central Asian peoples. Today, because the Islamic belief of these groups is seen as a bulwark against Chinese cultural hegemony, there is an increasing trend among Uighur and Kazakh women to wear international Islamic *hijab* clothing, which consists of a shapeless outer garment and headscarf.

Tibet, now the Tibet Autonomous Region of the People's Republic of China, retains a strong indigenous dress tradition. The basic garment for both sexes is the *chupa*, a narrowly cut, long, side-closing wrapped garment bound at the waist with a sash. Men often wear a sheepskin coat over the *chupa*, leaving the right arm out of its sleeve and the right side of the coat pulled down off the

shoulder—this is supposedly to facilitate knife- or sword-fighting should the need arise. An alternative women's ensemble consists of a loose, long-sleeved blouse, a dress, often of plain black cotton, with a sleeveless jumper top and a skirt that wraps in back and ties at the waist with cords, giving a trim line to the garment. It is worn with an apron sewn from several strips of multicolored, horizontally-striped cloth—a badge of married status for women. As in many cultures with a tradition of pastoral nomadism, Tibetan women often wear a wealth of jewelry, favoring in particular silver ornaments set with turquoise, coral, and lapis lazuli.

See also **Asia, Central: History of Dress; Asia, South: History of Dress; China: History of Dress; Hijab; Japanese Traditional Dress and Adornment; Kimono; Korean Dress and Adornment; Qipao.**

### BIBLIOGRAPHY

- Crihfield, Lisa Dalby. *Kimono: Fashioning Culture*. Rev. ed. New Haven, Conn.: Yale University Press, 1993.
- Fairservis, Walter, Jr. *Costumes of the East*. New York: American Museum of Natural History, 1971.
- Garrett, Valery M. *Chinese Clothing: An Illustrated Guide*. Hong Kong: Oxford University Press, 1994.
- Kennedy, Alan. *Japanese Costume: History and Tradition*. New York: Rizzoli, 1990.
- Roberts, Claire, ed. *Evolution and Revolution: Chinese Dress, 1700s–1990s*. Sydney: The Powerhouse Museum, 1997.
- Vollmer, John E. *In the Presence of the Dragon Throne: Ch'ing Dynasty Costume (1644–1911) in the Royal Ontario Museum*. Toronto: Royal Ontario Museum, 1977.
- Wilson, Verity. *Chinese Dress*. London: Bamboo Publishing Ltd. in association with the Victoria and Albert Museum, 1986.
- Xun, Zhou, and Gao Chunming. *5000 Years of Chinese Costumes*. San Francisco: China Books & Periodicals, 1987.
- Yang, Sunny. *Hanbok: The Art of Korean Clothing*. Elizabeth, N.J.: Hollym International, 1998.

John S. Major

**ASIA, SOUTH: HISTORY OF DRESS** South Asia comprises India, Pakistan, Bangladesh, Sri Lanka, Nepal, and Bhutan. The geographical terrain varies from mountainous regions along the northern borders, to desert areas, arid and semiarid zones dependent on monsoon rains for agriculture, the uplands of the Deccan Plateau, tropical wetlands, and the rich valleys of the Indus and Ganges rivers, seats of ancient cultures.

Despite differences in physical appearance, language, and other ethnological features, the people of South Asia share to a considerable degree a common cultural heritage. Sanskrit and Prakrit, the languages of the region's most ancient texts, are still employed in religious rituals and classical learning. The *Mahabharata* and *Ramayana*, great epics dating from ca. 500–300 B.C.E., reinforce cultural links and a sense of shared tradition throughout the region.



**Pakistani man in native clothing.** The national dress of Pakistan is the long tunic, or *kamiz*, and loose-fitting pantaloons called *salwar*. © CORBIS. REPRODUCED BY PERMISSION.

Draped and wrapped garments are the most common form of clothing for both men and women in South Asia. The sari (also spelled *saree*), in many variant sizes and wrapping techniques, worn with a *choli* (blouse), is the most typical form of South Asian women's dress. An analogous wrapped garment for the lower torso and legs, the dhoti, is widely worn by men; it is usually wrapped and tucked to form a kind of unstitched pantaloons. In some areas both sexes wear the sarong (also known as a *lungi*), a wrapped skirt. Stitched garments are also widely worn in the region by both men and women; examples include the loose trousers called *payjamas*, and the ensemble of *salwar* (pantaloons) and *kamiz* (long tunic) that has become the national dress of Pakistan.

Wrapped and draped garments appear to be the oldest form of attire in South Asia. Nevertheless, awls found at archaeological sites of the Harappan civilization, in the Indus Valley (third millennium B.C.E.) indicate that leather stitching and embroidery were practiced there. Stitched garments entered the region with ancient migrations of people from Central Asia. The assumption made by some European scholars that Muslims intro-

duced tailoring to South Asia is incorrect. Early literature preserves words for the needle (*suchi*), the thimble (*pratigraba*), scissors (*sathaka*), and even for the sewing-bag, showing that tailoring was practiced in ancient times.

### Early Evidence

An early Harappan sculpture depicts a priest's draped garment with an embroidered trefoil motif. Women are shown wearing elaborate headgear and a scanty wrap around the hips and pubic area, a form of dress used even today by some tribal people of Central India.

The early Vedas (ca. 1200–1000 B.C.E.) mention shining raiments, indicating the use of gold thread. The *Mahabharata* and *Ramayana* describe elaborate garments, but their form is unclear. Draped garments continued to dominate in post-Vedic times and had evolved into an elaborate costume with distinctive names. *Antariya* was the lower garment, while the upper was *uttariya*. The lower wrapper was held in place by an elaborate sash or a girdle of jewelry and the upper wrapper was draped with innumerable folds. Embroidered wrap skirts, *pesas*, were also used; they are similar to skirts worn in Gujarat. Another garment of post-Vedic times was a breast cloth, *pratidi*, tied or wrapped even today by the hill tribes of Bangladesh.

Later stone sculptures show a form of pleated lower wrap formed into a pantaloons created by passing the lower pleats through the legs and tucking them in at the back. There were variations of this technique, with descriptive names such as "elephant's trunk" and "fish tail," a style of wearing which continues to be used even today. Men and women used a wrapped head covering called *usnisa*, which was quite distinct from the later turban.

Cotton was most commonly used for textiles, along with other plant fibers and wool. Silk was indigenous to Assam. Silk cloth had connotations of purity, as was also true of wool in mountainous areas.

### Historical Survey

South Asia's first major empire flourished under Chandra Gupta Maurya (320–297 B.C.E.) and his grandson, Ashoka (274–237). They forged contacts with Central Asia, China, and the Greek world (which had expanded far into Asia under Alexander the Great). Chandra Gupta married a Greek princess and had Greek women bodyguards. The presence of Greek women at the Mauryan court possibly had significant consequences for the history of South Asian dress; the Greek women's single-piece draped *chiton*, pleated as a skirt and draped over the shoulder, may have been an ancestor of the sari. A Greek ambassador named Megasthenes gave a detailed description of gold-embroidered garments, printed muslin, and a life of great luxury. The elaborate drappings of Greco-Asian Gandhara sculpture of the northern area reflect the local costume, while stitched garments are depicted as being worn by soldiers, possibly of Central Asian origin.

The Satavahana Empire in south India (200 B.C.E. to 200 C.E.) encouraged trade with the Roman Empire, Arabia, and Southeast Asia. Unstitched garments are shown in Satavahana sculptures, along with stitched garments such as a tunic with V-neck and sleeves. Soldiers wore sleeved tunics with tight trousers.

The Kushans, known to the Chinese as the Yueh-Chi, dominated Central Asia during the period from 130 B.C.E. to 185 C.E. They entered the Punjab, destroying the local rulers and consolidating their rule by defeating the Greeks and the Scythians (Sakas), who dominated Western India. The presence of Greeks, Kushans, and Sakas introduced varying cultural traditions. The monolithic statue of Kanishka at Mathura has a long coat worn over a tunic. The coat's open front flaps turn outward exactly in the same way as Turkoman coats worn in the twenty-first century. Women wore jackets over their sarongs held together with decorative buttons, and tunics with sleeves and rounded necks, probably opening at the back. A dancer wore a tunic, pajama pants, a floating scarf, and a cap, similar to later Central Asian dance costumes and also to the costume worn by the women dancers of Kathak, a classical dance of North India.

Stitched garments became common during the Gupta period (fourth to eighth century C.E.), for the Gupta rulers controlled territories from Central Asia to Gujarat. The Gupta-era murals at Ajanta, however, show royalty wearing flowing garments while the attendant, entertainers, and soldiers wore stitched clothes. Women wear a range of blouses, known by names similar to *choli*, the word for blouse today. The backless blouse with an apron worn by the dancer in the murals is still worn by some nomadic peoples.

The Sanskrit and Prakrit lexicons of the seventh century C.E. contain a wide range of terms for clothing, many of which are closely related to words that are in use today. This lexical continuity shows that upper wraps, veils, jackets, tunics, and various other types of garments have continued in use from that time to the present.

The conquest of most of Central Asia and northwestern India by Mahmud of Ghazni in the eleventh century played a major role in bringing Islam to South Asia. The Islamic influence exerted by the Ghaznavids and their successors had a notable effect on the clothing of South Asia. There was an extensive trade in textiles between India and the Middle East; records specifically mention fabrics for lining and edging, indicating a highly evolved style of stitched costumes. Mention is also made of costumes coming from Syria, Egypt, and Baghdad to be used by the Sultans and their court. Textiles were also produced locally under the patronage of Muslim rulers.

Robes decorated with woven or embroidered calligraphy were worn throughout the Islamic world. They originally were produced in textile workshops (*Dar-al-Tiraz*) set up by the Caliphate in Baghdad. They came up, however, throughout the Islamic world to serve the

courts. Designs and techniques were exchanged from one area of the Islamic world to another and were incorporated into garments for royalty and robes of honor. The rulers of various sultanates of northern India set up their own royal textile workshops; one was described by the inveterate Arab traveler Ibn Batuta and thus the Indian courts began to follow the dictates of fashion set by the caliphate.

The consolidation of the Mogul Empire during the late sixteenth and early seventeenth centuries led to changes in governance and court life through the country. Lesser rulers followed the dictates of the ruling Mogul emperor. Humayun, who experienced the sophisticated life of Shah Abbas's court in Persia, evolved an urbane way of life. He returned with masters of many arts to set up royal ateliers in Agra and Lahore. He laid the foundation of the indigenous Mogul style, which Emperor Akbar (1556–1605) perfected. Abul Fazl, Akbar's chronicler, records that the Akbar's wardrobe contained dresses designed by the emperor himself to be suited to the Indian climate. He describes an unlined cotton coat in "the Indian form" tied on the left side, while Hindus tied theirs on the right. (The difference persists to this day.) He introduced the double shawl used by men, a style in keeping with the flowing garment of the Indian tradition. Foreign names for introduced garments were changed to indigenous or Sanskritized versions to enhance their acceptability.

Mogul miniature paintings demonstrate that fashions in clothing were dictated by the court. Men wore long coats over pantaloons, and turbans with jeweled plumes. In Akbar's court *chakdar jama*, a long coat with pointed corners was fashionable, while Jehangir introduced a fitting *Nadiri* coat. In the early Mogul period, the dress of men and women was similar, but during Jehangir's reign women's fashions changed. Miniatures show layers of fine muslin garments floating over rich brocaded tunics with gossamer tissue veils. Indigenous textiles and skills inspired a range of costumes influenced by local fashions.

The Mogul Empire's decline shifted patronage to regional courts and led to indigenous styles. A long, trailing coat was worn at the sophisticated court of Oudh. Women's pajamas evolved into elaborate slit skirts called *farshi payjama*. Only Hindu women wore skirts.

The impact of European clothing on India was gradual. In the seventeenth and eighteenth centuries, many European men adopted Indian dress and married or lived with Indian women. The arrival of substantial numbers of European women in the mid- to late nineteenth century brought about a change of lifestyles. The formation of a colonial government and the evolution of a formal social life led to a more formal dress code. The Indian civil servants, soldiers, and students were expected to dress accordingly. The Indian elite adopted the Western mode of dress, while the middle class blended it with their own. The Bengali *babu* wore his dhoti with a shirt, a coat,



and an umbrella. In southern India, men wore the coat and shirt over the sarong. Women began wearing blouses imitating the neckline, collars, and puffed sleeves of Western fashion. The tunics of North India also followed some of the European fashions.

### General Regional Styles

Despite the fact that South Asia preferred the use of draped garments, regional variations occur throughout the area. These are influenced by geo-climatic conditions, and sociocultural environment.

### North India and Pakistan

In North India and Pakistan, stitched costumes similar to those of Central Asia are prevalent. Men and women wear a tunic called a *kamiz*, together with *salwar*, loose pantaloons, narrow at the ankles and tied at the waist. (The *salwar* is cut quite differently from the pajama.) The versions of *salwar kamiz* worn by men and women are similar but have a different cut and styling. In addition to the tunic and pantaloons, women wear a veil, *dupatta*, which is a head covering, and can envelop the body. Pakistan's women have adopted *salwar kamiz* as their national dress; for outdoors, many women wear a burqa over the *salwar kamiz* that covers them from head to toe.

In Greater Punjab (extending into both India and Pakistan), Sindh, and the North-West Frontier Province of Pakistan, people wear a longer style of tunic, called a *kurta*, as well as *salwar*. The embroidered tunic worn by women in Pakistan's Sindh and Baluchistan areas is similar to the one worn by the Baluchi women of Afghanistan and Iran.

The Hindu, Muslim, and Sikh peasants wore a long wide sarong known as *lacha* made of cotton, worn long at the back and knotted in the front, with the ends tucked into the side. Affluent landlords wore a silk *lacha* with broad borders. Men wore turbans with a crestlike fan rising from behind and a long, flowing end falling down the wearer's back. The Jats of East Punjab and Haryana in India wear a similar dress.

The men and women of Kashmir wear a long, loose tunic, *pheran*, with a *salwar* or a pajama; the Kashmir tunic is quite distinct from the *kamiz*. The women's tunic has embroidery at the neck and is worn with a headscarf.

### Ladakh

Sometimes known as lesser Tibet, the small Himalayan territory of Ladakh maintains Buddhist lamaistic traditions. Men wear a long, woolen coat with side fastenings, with a shirt and a sash. Everyone wears a tall hat with an upturned rim, richly embroidered for special occasions. Women wear a long velvet dress, with a sheepskin, *lokp*, suspended from the shoulders at the back like a short cape, which is replaced by a brocade or richly embroidered version for festive occasions. Women also wear an elaborate headdress, *perak*, covered with large pieces of

turquoise, which curves over the head like a cobra hood and hangs down the back.

### Indian Regional Costumes

In northwestern India, the women of Gujarat and Rajasthan wear a wrapped skirt, *jimmi*, or a wide skirt, *gha-gro*, with a fitting backless blouse, and a veil. The blouse has many variations, as described in the ancient literature. In Saurashtra and Kutch, men of the Kathiawari ethnic group, descendants of the Huns, wear a pleated blouse (*keddia*), tight pajamas, a large shawl around their waist, and a turban, a costume similar to some peasant costumes in the Balkans. People in the Tharparkar and Sindh areas of Pakistan dress in a similar manner. Hindu women wear a skirt, a backless blouse, and veil, while Muslim tribal women wear a thigh-length backless blouse, an embroidered *salwar*, and a veil. In the urban areas of Gujarat, men wear a *dhoti* with a shirt, while women wear a fourteen-and-a-half-foot sari with a cross border worn in the front.

In central India and the western coastal area, Hindu and tribal men and women wear unstitched garments. Urban men wear stitched upper garments during winter or for special occasions. Women of different groups wear saris of 137 inches to 312 inches in length (3½ meters to 8 meters in length). Tribal women wear shorter saris, while urban and more affluent women wear longer ones. They are wrapped so as to create unstitched pantaloons by taking the front pleats, passing them between the legs, and tucking them into the back. This style of sari wrapping is associated with women's chastity. Women in south India (including Karnataka and Tamil Nadu) wear the sari in a variety of styles, depending on geo-climatic conditions and cultural traditions.

Women in Kerala, in southwesternmost India, wear sarongs instead of saris, while men wear a white double-layered sarong, with an upper-body cloth along with a shirt.

Muslim men and women throughout India wear stitched garments. The common dress for men is a *kurta* (long tunic) and pajama. The affluent wear an embroidered coat, *angarkha*, and embroidered cap. For official occasions they wear a fitting long coat, *sherwani*, and tight pajama. The turban varies according to their vocation, the occasion, and their age. Women wear a tight pajama, a fitted shirt (often with a jacket), and an embroidered veil. For outdoors many women wear the burqa. Among the affluent, *farshi payjama*, a trailing, wide divided skirt, is worn for special occasions. Among non-Muslims, such as Hindus and Jains, stitched garments have to be removed by men and women for religious ceremonies or for entering a temple.

### Sri Lanka

Sri Lanka, a large island lying at the southernmost tip of India, was an important maritime center from ancient times, linking the East with the West. The Greeks called





**Refugees in Pakistan.** In many South Asian countries, Muslim women wear *saris* inside the home, but are obliged to wear head-to-toe coverings called *burqas* outside the home. © LYNSEY ADDARIO/CORBIS. REPRODUCED BY PERMISSION.

it Taprobane, and the Arabs Serendib. Sri Lanka's recorded history dates from the mid-first millennium B.C.E. Around 400 B.C.E. King Pandukabhaya began developing the arts and established close contacts with Buddhist India. Theravada Buddhism remains the dominant religion of Sri Lanka's majority Sinhalese people today. Early sculptures show close linkages with Indian tradition and the figures are seen wearing flowing draped garments.

Sri Lanka has absorbed a great deal of external influence during its history. Arab traders drawn to the spice and textile trade visited the island from late Roman times onward. Colombo and Galle had colonies of Arab traders, who introduced Islam to Sri Lanka. Portuguese traders settled in coastal areas in the early sixteenth century. The Portuguese settlements were taken over by the Dutch in the mid-seventeenth century; the British, who established a colonial regime in 1833, in turn, expelled the Dutch. European influence on Sri Lankan culture can be seen in dress, especially among the so-called Burghers, who are of mixed Dutch and Sinhalese ancestry. Early drawings show Burghers mingling traditional dress with European elements. Men wore over the sarong a long coat with puffed sleeves and a sash, as well as a hat. Women dressed in a sarong and upper cloth combined with European

jackets. However, many people continued to wear clothing not affected by European influence.

The Sri Lankan population includes two major elements, the Sinhalese and, especially in the northeastern part of the island, the Tamils. The latter were migrants from southeastern India, many brought in by the British as plantation workers in the nineteenth century. The two communities have distinctive clothing traditions.

The traditional dress of the Sinhalese women is the sarong worn with a stitched blouse and a scarf over the shoulder. In some cases the sarong has a frill at the top. Some wear a blouse with lace inserts at the waist and the sleeves, with a silver belt. Men wear a sarong and a *kamiz* (tunic). The fact that two women heads of state have always worn the Sinhalese national dress has influenced even the Burghers to adopt the traditional costume. Tamil women wear the saris draped in the traditions of their community, while the men wear the *veshti*, a white sarong. Muslim men, who trace their roots to Arab settlers, wear a colorful sarong with a tunic and a cap. Muslim women traditionally wore local dress; however, in the early 2000s many have adopted Islamic dress, including wearing the headscarf.

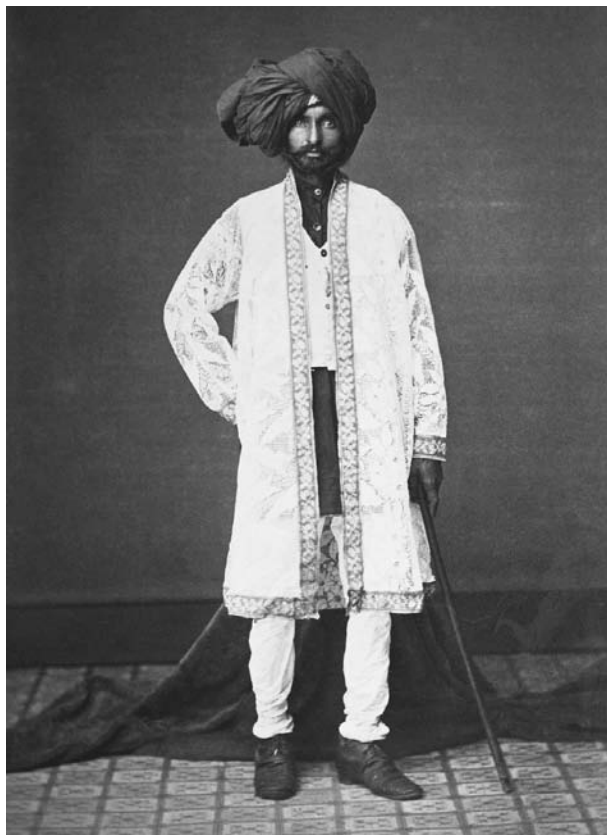

**A Sri Lankan Hindu in traditional attire.** While some Sri Lankan attire has been influenced by Arab and Western styles, others have remained untouched by these outside elements.  
© BETTMANN/CORBIS. REPRODUCED BY PERMISSION.

## Nepal

The Royal Kingdom of Nepal, a landlocked area with the highest mountains of the world, extends from the Gangetic plains to the Himalayas. The country's climate ranges from alpine cold, to hot and arid, to hot and humid. The country has many different ethnic groups, but they fall into two main divisions. In the mountains are found peoples of Tibetan origin, while people of Indo-Aryan origin live mostly at lower elevations.

Early references to clothing in ancient texts indicate that the various peoples of Nepal had diverse clothing traditions from ancient times and that some of those traditions persist to the present day. The earliest reference to Nepalese textiles is in Kautalya's *Arthashastra* (250 B.C.E.). It refers to black blankets stitched together from eight pieces. These continue to be used as a wrap by the people. Historic dress styles can be studied from sculptures, murals, and book illustrations. Draped and wrapped garments dominate, along with stitched jackets. In the early fifteenth century, the ruler classified the dress of sixty-five sub-castes; for instance, some were prohibited from wearing coats, caps, and shoes and others from having sleeves on their jackets.

Newari women of the central valleys and the lower mountain ranges wear a pleated wraparound skirt held together by a heavy shawl at the waist, while the men wear a long shirt, *nivasa*, pleated up to the waist and reaching to the ankles, which is worn with a waist cloth. A jacket and a *topi*, conical cap, completes the outfit. Gurkha men wear ordinary trousers with a blouse reaching below the hips and fastened by a heavy cummerbund with the *kukri* traditional dagger stuck into it.

The Kirant, one of the larger ethnic groups, wear an interesting blouse called *choubandi*, which means "four knots." The blouse crosses over, tying at the armpit and at the waist. Women wear it waist-length, while the men's comes to the hip. Women also wear a wraparound skirt with a sash. The Tharus of Terai wore wrapped skirts made from multicolored panels and appliqué blouses.

Ethnic groups of Tibetan heritage, such as the Sherpas and Dolpos, generally wear clothing similar to that of Tibet. These include, for women, a silk blouse and a wrapped skirt, worn with a narrow apron of brightly colored stripes, stitched together from three pieces. Men wore woolen coats and trousers or left their legs bare. The Dolpo's woolen coat, *chuba*, came with multiple panels and had a distinctive style. Both groups use long sheepskin or goatskin fleece coats to ward off the high mountain cold.

The distinctive characteristic of Nepali dress was the more affluent the wearer the greater the length of cloth. Royal women used 80 to 90 yards of material for their gathered skirts. These thick and heavy skirts were worn with a thick sash to protect against back strain.

## Bhutan

The Royal Kingdom of Bhutan is east of Nepal, between northeastern India and Tibet. The country is mostly mountainous. The majority of inhabitants, of Tibetan culture and ethnicity, live in the principal valleys among the high mountains. A hot and humid lowland area on the southern fringe of the country is home to many Nepalese immigrants. Finely woven woolen textiles are produced in the highlands, while cotton and silk is produced and woven in the lowlands.

Traditional dress is mandatory in Bhutan. Men wear Tibetan-style tunics, *gbo*, with a belt; the style is, however, quite distinct. It is raised and tied at the waist with the legs left bare for greater mobility. Rich woven patterns give the tunic a distinctive character. Ceremonial scarves are essential for all rituals and ceremonies and the color denotes the status of the wearer. Even their raincoats woven out of yak wool and dyed with vegetable dyes, *char-khab*, are beautifully patterned.

Many men are monks and wear Tibetan Buddhist-style burgundy or orange woolen wrapped robes stitched together from separate pieces of cloth. Women wear a wraparound dress of wool or silk, *kiru*, with a sash. Silver brooches with a pin, *koma*, hold the wrapped dress in



**Young Bengali women.** Women of the Bengal region typically wear draped cotton *saris* over blouses (*cholis*), and those who practice the Hindu religion drape the end of the sari over the head to form a veil. © ROGER WOOD/CORBIS. REPRODUCED BY PERMISSION.

place. Over this they wear a jacket, *toego*, which gives the dress a very elegant style. A shoulder shawl, *rachu*, is essential for entry to the Dzong or in the presence of royalty or high officials. The finest *kiru*, known as *kushtharas*, is a highly elaborate weave and is worn mostly by royalty.

### Bangladesh

The Vanga or Banga Kingdom is mentioned in early Sanskrit literature (1000 B.C.E.) and it was known as one of the earliest Indian kingdoms to embrace Buddhism. Bengal has a strong, local cultural tradition and has long had contact with Southeast Asia and with the West, via Arab

traders. Portugal was the first European state to have direct contact with Bengal. The region is ethnically diverse, with a Bengali-speaking majority in the broad river valleys and lowlands, and with hill tribes, especially in the east, that have connections with the peoples of Myanmar (Burma).

In 1576 C.E. the Moguls conquered Bengal, incorporating it into the Mogul Empire. The British East India Company established a trading settlement in 1651. Bengal was assimilated into the British Empire, and Calcutta became the seat of the empire, as well as the hub of the trade. The partition of India in 1947 saw East Bengal, which had a Muslim majority, become East Pakistan,



while West Bengal, with a Hindu majority, remained part of India. In December 1971 East Pakistan became the sovereign state of Bangladesh.

Bengal was known from early times for its gossamer Dacca muslin, which was in demand throughout the world. Women spun cotton thread to the fineness of 400 count. The Roman senate bemoaned emptying their coffers to pay for this fine muslin. Caesar complained that his wife appeared naked in public and she responded that she wore seven layers of the Indian cloth.

The women of both West Bengal and Bangladesh wear cotton saris in the typical Bangla style of fold upon fold. Hindu women use the long end of the sari as a kind of veil by draping it over their head; Muslim women wear the sari at home in the same manner but cover it with a burqa outside the house. Muslim peasant men wear a colorful *lungi* (sarong), with short vest. Hindu men wear a *dboti* (unstitched pantaloons), a vest, and a shoulder cloth. Urban Muslim men wear loose pajamas with a tunic known as a *Punjabi*. For formal occasions the men wear fitting, long coats, *sherwani*, with tight pajamas, while Hindus wear cotton or silk *dbotis* with *Punjabi* and a shawl. Tribal women wear sarongs and breast cloths with intricate patterns, woven on backstrap looms. Among some tribal women, the intricately woven sarong was formerly worn from the breast to the calf. The custom of wearing blouses with the sarong or sari was introduced much later. The younger generation has taken to wearing the *salwar kamiz*.

### Conclusion

South Asia has the distinctive characteristic that women have maintained their traditional way of dress. The elite younger generation does wear Western dress and the universal jeans, but for special occasions and as they settle into domesticity, they wear their local dress. However, the different styles of wearing the sari in different regions dictated by the geo-climatic conditions and local culture is now disappearing. The eighteen-foot sari with the cross border thrown across the left shoulder has come to dominate throughout India, Bangladesh, and Sri Lanka; upper-class women of Nepal also wear the sari.

The freedom struggle and search for identity had led to the use of *khadi*, handspun handwoven cotton, and the Gandhi *topi* (cap), which became associated with the freedom struggle. After independence and the need for creating a national identity led to the introduction of the Jawahar jacket, a sleeveless fitting jacket worn with Indian clothes made fashionable by the first prime minister, Jawaharlal Nehru, as well as the Jodhpur coat, a close necked full-sleeved short coat worn with trousers as semi-formal dress and the *sherwani* or *achkan*, a long coat worn with tight *churidar* pajama and formal dress.

Pakistan guards its separate identity and the women wear the *salwar kamiz*, which has also spread to Bangladesh and southern India. Women's magazines and Bollywood films have had an important influence in making the

women innovative in enriching their costume. This began even before the advent of India's National Institute of Fashion Technology in the 1980s and the proliferation of boutique culture in the hands of young fashion designers, who are setting new trends in South Asian styles of dress.

See also **Colonialism and Imperialism; Cotton; Religion and Dress; Sari; Silk; Textiles, South Asian; Traditional Dress.**

### BIBLIOGRAPHY

- Abul-Fazl. *Allami, The A'in-I-Akbari*. Translated by H. Blochmann. 3rd ed. New Delhi: South Asia books, 1977.
- Agrawala, V. S. "References to Textiles in Bana's *Harsbacharita*." *Journal of Indian Textile History* (1959).
- Ali, A. Yusuf. *Monograph on Silk Fabrics Produced in the North-Western Provinces and Oudh*. Allahabad, 1900; reprint Ahmedabad, 1974.
- Alkazi, Roshen. *Ancient Indian Costume*. New Delhi: Art Heritage, 1983.
- Askari, Nasreen, and Rosemary Crill. *Colours of the Indus*. London: Merrill Holberton and the Victoria and Albert Museum, 1997.
- Baker, Patricia L. *Islamic Textiles*. London: British Museum Press, 1995.
- Bartholomew, Mark. *Thunder Dragons Textiles from Bhutan*. Kyoto, Japan: Bartholomew Collection, 1985.
- Beer, Alice Baldwin. *Trade Goods: A Study of Indian Chintz*. Washington, D.C.: Smithsonian Institution Press, 1970.
- Bhushan, Jarmila Brij. *The Costumes and Textiles of India*. Taraporevala, Bombay, 1959.
- Chandra, Moti. *Costumes, Textiles, Cosmetics and Coiffure in Ancient and Medieval India*. Delhi: Oriental Publishers on behalf of the Indian Archaeological Society, 1973.
- . "Indian Costumes and Textiles from 8th to 12th Century." *Journal of Indian Textile History* 5 (November 1960): 1–41.
- Chopra, P. N. "Dress, Textiles and Ornaments during the Mughal Period." *Proceedings of Indian History Congress*, 15th Session. Calcutta, 1954. Pp. 210–228.
- Dar, S. N. *Costumes of India and Pakistan*. Bombay, India: D. B. Taraporevala Sons and Company, 1982.
- . "Survey of Embroidery Traditions." In *Textiles and Embroideries of India*. Bombay: Mark Publications, 1965.
- . *Folk Arts and Crafts of India*. New Delhi, India: NBT, 1970.
- Dhamija, Jasleen. *Crafts of Gujarat*. New York: Mapin, 1985.
- . "Telia rumals, Asia rumal, Real Madras Handkerchief (RMH): Footnote to Global Textile Trade." Paper presented to the conference Cloth, the World Economy and the Artisan, Dartmouth, N.H., 1993.
- . *The Woven Silks of India*. Bombay, India: Mark Publications, 1995.
- . *Woven Magic*. Jakarta, Indonesia: Dian Rakyat, 2002.
- Dhamija, Jasleen, and Jyotindra Jain. *Handwoven Fabrics of India*. New York: Mapin, 1981.
- Elson, Vickie G. *Dowries from Kutch*. Los Angeles: UCLA Museum of Cultural History, 1979.



- Frater, Judy. *Threads of Identity*. New York: Mapin Publishing, 1995.
- Gajurela, Chavilala. *Traditional Arts and Crafts of Nepal*. New Delhi, India, 1984.
- Gelfer, Agnes. *A History of Textile Art*. London, 1979.
- . "Some Evidence of Indo-European Cotton Trade in Pre-Mughal Times." *Journal of Indian Textile History* 1 (1955).
- Guy, John. "Sarasa and Patola: Indian Textiles in Indonesia." *Orientalism* 20, no. 1 (1989).
- . *Woven Cargoes: Indian Textiles in the East*. London and New York: Thames and Hudson, Inc., 1998.
- Hitkari, S. S. *Phulkari: The Folk Art of Punjab*. New Delhi, India: Phulkari Publications, 1980.
- Jain, Jyotindra, and Aarti Aggarwala. *National Handicrafts and Handlooms Museum*. New Delhi, India, 1989.
- Krishna, Rai Anand. *Banaras Brocades*. New Delhi, India, 1966.
- Maxwell, Robyn. *Textiles of South East Asia*. Melbourne, Australia: Australian National Gallery; Oxford University Press, 1990.
- Mayors, Diana K. *From the Land of the Thunder Dragons: Textile Arts of Bhutan*. New Delhi, India: Timeless Books, 1994.
- Nambiar, Balan, and Eberhard Fischer. "Patola/Viralu Pattu—from Gujarat to Kerala. New Information on Double Ikat Textiles in South India." *Asiasche Studien: Etudes Asiatiques* 41, no. 2 (1987).
- Pavinskaya, Larisa R. "The Scythians and Sakians: Eighth to Third Centuries B.C." *Nomads of Eurasia*. Los Angeles: Natural History Museum of Los Angeles County, 1989.
- Religious & Cultural Traditions of Bhutan*. Catalog of Exhibition. Department of Culture. India & National Commission for Cultural Affairs. Bhutan. October 2001.
- Scott, Philippa. *The Book of Silk*. London and New York: Thames and Hudson, Inc., 1993.
- Tucci, Giuseppe. *Transhimalaya*. Translated by James Hogarth. London: Barrie and Jenkins, 1974.
- Vogelsang-Eastwood, Gillian. *Resist Dyed Textiles from Quseir al-Qadim*. Egypt, Paris, 1990.
- Wilson, Kax. *A History of Textiles*. Boulder, Colo.: Westview Press, 1979.

Jasleen Dhamija

## ASIA, SOUTHEASTERN ISLANDS AND THE PACIFIC: HISTORY OF DRESS

Prior to Western contact that began as early as the sixteenth century, clothing in the islands of Southeast Asia and the Pacific was minimal due in part to the islands' tropical conditions. Bark cloth was produced on all of these islands and was made by felting fibers from the inner bark of the paper mulberry tree. Simple wrapped garments were worn primarily over the lower body, and some cultures occasionally wore unconstructed garments on the upper body as well. Dress included not only the wearing of bark cloth, but also involved tattooing for both sexes. As woven textiles were introduced into these islands, bark cloth pro-



**Tattooed Polynesian man.** Early Islanders used body art to express social and political standing. Clothing was minimal, and natural dyes were used to paint and tattoo the skin. © ROBERT HOLMES/CORBIS. REPRODUCED BY PERMISSION.

duction was reduced; where still produced it is used primarily for ritual purposes.

The islands of Southeast Asia (Malaysia, Indonesia and the Philippines) are the product of multicultural influences that began with trade along the sea lanes. Portuguese, British, Dutch and Spanish colonialism had an impact on the development of traditional dress. Although Western dress is worn in the islands today, traditional dress continues to be worn in villages and throughout these islands for ritual and ceremonial occasions. Brief details regarding the dress of the three major Southeast Asian islands (Malaysia, Indonesia and the Philippines) and the major Pacific Islands (Hawaii, Tonga, Samoa, Tahiti, the Marquesas and Cook Islands) will be provided here.

Malaysia is a Muslim country divided into West Malaysia, a peninsula of Southeast Asia, and East Malaysia, the northern portion of the island of Borneo, the rest of which belongs to Indonesia. The traditional textiles and dress of Malaysia and Indonesia are somewhat similar. Both island nations have developed highly



**An Indonesian couple in everyday dress.** The woman wears a traditional *kain*, while the man wears Western-style clothing. The variety of dress-styles in Indonesia is an indicator of local, Islamic, and Western influences on the country. JOHN S. MAJOR. REPRODUCED BY PERMISSION.

complex textiles, and the designs for these fabrics carry much symbolic meaning with regard to an individual's social status. Luckily, this traditional art is still considered to be important even in the face of westernization. Indonesia and Malaysia are known for textiles made with complex resist-dyed techniques; these include batik and ikat. Similarly, both Malaysia and Indonesia produce *songket*, a complicated fabric with a supplementary weft of gold, silver and other metallic threads.

In Malaysia, traditional clothing includes a lower body covering (sarong) worn by both sexes. Men's sarong are plaid, women's are designed with floral patterns. The upper body covering for men is a shirt referred to as a *baju*. For women, a sheer blouse referred to as a *kebaya* is worn in Malaysia. Sheerness is less acceptable today so a more accepted form of dress for women, especially in cities, is the *tudung*—an ensemble of a long-sleeved tunic and floor-length skirt accompanied by a head scarf.

Indonesian national dress derives from the Muslim inhabitants of Indonesia's main island, Java. Dress is an indicator of cultural change in Indonesia where history can

be divided into three eras categorized by dress terms: sarong (local dress), *jubbah* (Islamic influences) and trousers (Western influences). Although Western dress is most commonly worn in Indonesia's urban areas today, traditional textiles are used even in Western-styled clothing, and traditional dress styles continue to be important in Indonesia, where varied forms of traditional dress testify to the wide variety of subcultural groups in the nation.

Traditional dress is still commonly seen in rural areas and is especially important throughout Indonesia for national ceremonial occasions. For both sexes, traditional dress in Indonesia includes a wraparound lower-body cover (*kain*, a rectangular length of fabric, generally in batik), or a sarong (more often in ikat). Women in Java and Bali wear *sarongs* and *kain*, held in place with a *stagen*. The *kebaya* is a tight, often sheer, long-sleeved blouse worn on the upper body. It is often made of lace, and can be made of lightweight, sheer, elaborately embroidered cottons. In addition, women generally have a *selendang* (ikat or batik) draped over the shoulder (on less formal occasions a large *selendang* is used to carry babies or objects), or on Bali the *pelangi* is worn over the *kebaya* around the waist.

Indonesian men generally wear *kain* or sarongs only in the home or on informal occasions. A black felt cap or *peci*, is occasionally worn; though it was once associated with Islam it has acquired a more secular, national meaning in the post-independence period. These ensembles originated on Java and have become national dress in Indonesia because the vast majority of the population lives on Java and Bali. *Kebaya* and batik *kain* are considered Indonesia's national dress for women and *teluk beskap*, a combination of the Javanese jacket and *kain* are formal dress for Indonesian men. Shirts made with traditional batik and ikat designs are worn with trousers for less formal occasions.

Indonesians and Malays settled in the Philippines prior to the Spanish colonization during the sixteenth century. The dominant influence is Spanish Catholicism; priests were scandalized by the relative nudity of the Filipinos, who wore minimal lower body coverings. Spanish colonists brought Western notions of modesty and opulence in dress that influenced the styles of Filipino national dress. It retained features relevant to the environment; loose, light and long garments made of blended fibers of *pina* (pineapple fiber) and *jusi* (sheer raw silk) rather than the heavy silks and velvets brought by the Spaniards.

The early Filipino women wore the *baro't saya*, an ensemble of a loose, long-sleeved blouse over a wide skirt that fell to the floor. By the nineteenth century it evolved into the Maria Clara ensemble. The blouse (*camisa*) is a bell-sleeved blouse with a large, triangular, stiff shawl (*panuelo*) worn on top. From the Spanish, Filipinas learned to do embroidery, cutwork, drawn threadwork and other forms of surface design. *Camisas* and *panuelos*

were heavily embroidered. In the early 2000s, the Maria Clara is worn for formal events. The Maria Clara is still a two-piece dress, with large, butterfly sleeves. In the twentieth century, another garment called the *mestiza*, a sheath dress with butterfly sleeves became popular. For Filipino men, the *barong tagalog* is national dress, and is worn for a wide variety of activities. It evolved from the *canga*, a loose cotton shirt worn outside the trousers. Over time, and due to Spanish influence, the shirt evolved into a sheer embroidered shirt. For all traditional Filipino dress, *pina* and *jusi* are favorite fabrics, but less expensive silks and fine polyesters are also used. All are heavily embroidered.

### Pacific Islands

The islands in the Pacific Ocean were ruled by a hierarchy of hereditary tribal chiefs before European explorers visited in the eighteenth century. Visits by sailors had some impact, but the arrival of Europeans determined to stay in the islands was the key element leading to change in the dress of Pacific Islanders. The London Missionary Society saw it as their duty to convert the islanders to Christianity; to that end they sent missionaries in 1797 to the Society Islands, and with the support of the Pomares, the most powerful ruling family in the islands, by 1815 British missionaries had taken control of the islands. They did not just affect the islander's religious beliefs but had a significant impact on the culture by prohibiting traditional dance and music, while concurrently eliminating evidence of native religion.

Conflict between the French and British occurred on most islands as each nation tried to assert control. In the Marquesas, the French expelled the British and secured influence over the area, leaving the ruling Pomare family as token rulers. A French colony was proclaimed when King Pomare V was forced to abdicate in 1880 and within a few years it included the Marquesas, Society Islands, Austral Islands, Gambier Archipelago, and Tuamotu atolls. After World War II, Tahitians who had fought for France brought pressure against the government to extend French citizenship to all islanders; in 1957 the territory was officially renamed the Territory of French Polynesia.

Throughout all of the Pacific Islands, there has been a rebirth of indigenous culture since the 1970s. The Tahitian and Hawaiian languages are again taught in schools, and on some islands the indigenous language is even used in government meetings. Culture is being reclaimed from its near-death experience at the hands of missionaries, and in the islands the traditional arts, dance and music are now celebrated. The Pacific islands are now home to ethno-tourism, and the cultural displays of traditional arts are featured.

### Pacific Island Dress: Pre-Contact

Prior to the arrival of missionaries in the Pacific Islands, dress was an important expression of social status, polit-



**Traditional Javanese daily wear.** Indonesian men and women generally wear this wrap-around lower-body cover in the home or on informal occasions. The dress originated on Java, Indonesia's main island. PHOTO BY JOHN. S. MAJOR. REPRODUCED BY PERMISSION.

ical standing and religious belief. Body art and clothing were key elements that helped people to socially locate themselves and others. The body was the main focus of material expression. The body was tattooed, painted, and decorated with natural materials, dyes, and paints. In Eastern Polynesia, feathers twined onto heavy backings, provided for rich cloaks and helmets for members of the noble classes. Clothing was made from bark cloth (*tapa*, or in Hawaii, *kapa*) that was then decorated with motifs that varied from one culture to the next. Generally, only the lower body was covered with loincloths for men and wrapped skirts of *tapa* for women. Throughout Polynesia, skirts made of various fibers and leaves were worn by both men and women. In Western Polynesia, fine mats (*toga* in Samoa) were made of pandanus leaves and were used to cover the lower body. Fine mats symbolized the interweaving of lineages and are still ritually significant.

Dress was not just symbolic of status, but was used to signal submission, dominance, and respect in the islands. It was believed that clothing allowed the wearer to capture and transmit *mana*, a spiritual force over life, health, and death. To produce *tapa* was a source of power for women. These cultures had a pre-existing system of cultural meaning for dress that facilitated conversion to Western-style dress after contact. Although missionaries perceived islanders' adoption of new forms of clothing as





**Girl in traditional dress of Tonga Islands.** While native Tongan clothing such as this woven mat and feather headdress are still worn occasionally, many of the younger generation in the early twenty-first century were adopting Western-style dress. © WOLFGANG KAEHLER/CORBIS. REPRODUCED BY PERMISSION.

proof of conversion to Christianity, they failed to understand the multi-dimensionality of dress in the Pacific Islands.

In Hawaii, the arrival of Western trade goods began with the sandalwood trade beginning in 1810. For Hawaiian rituals, the *ali'i* (royalty) wore the splendid feather capes and cloaks which they traded to foreigners (*haoles*) for high prices or Western garments.

Prior to the arrival of permanent residents from the Western world, the standard Hawaiian costume consisted of only a lower body covering for both sexes. Indigenous Hawaiians made and wore *kapa* garments. Men wore a loincloth called the *malo*, and women wore the *pa'u*, a wrapped garment of *kapa* that often had applied geometric designs. Occasionally cape called a *kikepa* might be worn. By the time the missionaries arrived in 1820, the *ali'i* had already come to appreciate Western textiles as a substitute for *kapa*, and preferred calico. Although *kapa* was the traditional fabric, it could not be cleaned, did not wear well, and even one layer was stiff.

The *pa'u* passed several times around the waist and extended from beneath the bust to below the knee. For commoners, the *pa'u* was short and might be composed of only one or two layers of *kapa*, with each layer about four yards long and three or four feet wide. *Ali'i* wore as many as ten layers.

#### **Adoption of Western-Styled Dress: Post-Contact**

The process of conversion to Christianity in the Pacific was a slow process during the early nineteenth century; as one might expect, during that time there were a variety of transitions in clothing. For the missionaries, covering the breasts was required for the sake of Christian notions of modesty. While much has been written about the missionaries' insistence that the indigenous groups must be clothed in a way considered morally decent to the Europeans, there was at the same time agency on the part of the indigenous groups. On many islands, where status was denoted by dress, the dominant social groups were anxious for new styles to continue to assert their elevated social status. Consequently, when the missionaries arrived in the islands, their new fashions were rapidly adopted by the *ali'i*.

In the Cook Islands and on Tahiti, bark cloth ponchos were worn until woven textiles became available midcentury. Expatriates wore clothing from their original homelands, but Europeans created garments that were Western-styled and made of woven textiles for indigenous groups, as a means of ethnic classification. The indigenous groups made European-styled garments of native *tapa*, as seen in ponchos from Tahiti and the Cook Islands, and the *kapa holoku* was made in Hawaii. Tongan and Hawaiian nobility wore European garments regularly, and often wore Western clothing covered waist or hip wrappings of *kapa* (Hawaii) or woven mats (Tonga and Samoa). Woven mats over skirts of leaves in Samoa gave way to the use of *tapa* as a substitute for woven cloth. Christian Samoans were identified by the use of *tapa* rather than mats in the nineteenth century.

When woven textiles became more readily available throughout the Islands in the mid-nineteenth century, they were readily adopted for a number of reasons; for comfort and durability, to engender good relations with the missionaries, and, yes, for fashion.

Missionaries brought Victorian notions of style to the Pacific islands; that legacy is seen in brightly colored floral prints throughout the islands. The contemporary dress of islanders is derived from what has come to be known as "traditional" dress. The high-necked, yoked, loose garments introduced by missionaries, and made in bright floral prints, continue to be worn. Their origin was in 1820 when the Hawaiian queens requested dresses like those worn by the missionary wives. As the American women were quite small and wore empire-waisted dresses in the style of 1819, they decided that because the Hawaiian women were quite large, the high waistline

would not be attractive, and it was eliminated. The missionary wives designed the *holoku* as a long, loose dress with a high neckline and long sleeves. Until the 1930s they were made primarily in cotton calico prints and silk. The missionaries required the Hawaiian women to wear *holoku* when at the mission to signal ethnic differences. At the same time, they gave the Hawaiians chemises (knee-length slips), called *mu'umu'u*. The *holoku* was eagerly embraced by the upper-class women as a sign of their superior status. The *mu'umu'u* was not worn as a slip, as intended by the missionaries. Instead, it was used as a dress for sleeping in, or for swimming. It was not until the 1930s that the *holoku* became formal wear, and the *mu'umu'u* began to be made in bold cotton prints, and then became a common daytime dress.

As missionaries left Hawaii to convert other islanders, they took the *mu'umu'u* with them and introduced it to women on other islands. The *holoku* and *mu'umu'u* were the forerunners of the nightgown known in America as the Mother Hubbard, and that is the term for the floral print day dress worn in Vanatu. Similarly, this high necked, loose dress appears in many islands and now is considered traditional dress. Though they are quite similar throughout the islands, these garments have different names: they are referred to as Mother Hubbards (Vanatu); *vinivo* (Fiji); *pareau* (Tahiti), and *holoku* and *mu'umu'u* (Hawaii).

After Western contact, island men rapidly adopted Western dress, however on many islands wrap skirts of bright floral prints are worn (*lava lava*) while on some islands the wrap skirts are solid colors over which finely woven mats will be worn for special occasions. Aloha shirts developed on Hawaii in the early twentieth century, designed in the bold florals common to the islands. In twenty-first-century Hawaii, aloha shirts are daily wear for most men, and *mu'umu'u* are also common for women.

From the nineteenth-century beginnings of missionary activity in the islands, clothing has been and continues to be the focus of much debate. Missionaries wanted to do more than change the religious persuasion of islanders; they considered the adoption of Westernized dress as a symbolic manifestation of civilization.

Maintaining traditional island dress symbolizes reverence for the past and a preference for formality in the face of global change. Dress has become a focal point of conflicting values in the Pacific, as the older generation clings to old-fashioned standards of conveying modesty and respect through dress, while the youth wish to liberate themselves from the heavy legacy of the islands' missionary past.

In the Pacific, fashion activists and artists emerged in the 1990s; they use dress to illustrate issues of conflicts regarding ethnicity, globalization, and postcolonialism. In doing so, they use dress to critique their colonial pasts, and to overturn the status quo.

See also **Asia, East: History of Dress; Asia, South: History of Dress; Asia, Southeastern Mainland: History of Dress; Textiles, Southeast Asian Islands.**

#### BIBLIOGRAPHY

- Acjhad, Judy. "Traditional Costumes of Indonesia." *Arts of Asia* 6, no. 5 (1996): 74–79.
- Arthur, Linda. "School Uniforms as Symbolic Metaphor for Competing Ideologies in Indonesia." In *Undressing Religion: Commitment and Conversion from a Cross-cultural Perspective*, pp. 201–216. Oxford: Berg, 2000.
- . *Aloha Attire: Hawaiian Dress in the Twentieth Century*. Atglen, Pa.: Schiffer Publications, 2000.
- Arthur, Linda, ed. *Undressing Religion: Commitment and Conversion from a Cross-cultural Perspective*. Dress and Body Series, Oxford: Berg, 2000.
- Colchester, Chloe, ed. *Clothing the Pacific*. Dress and Body Series, Oxford: Berg, 2003.

Linda B. Arthur

**ASIA, SOUTHEASTERN MAINLAND: HISTORY OF DRESS** Southeast Asia is recognized for its legendary aesthetic in traditional woven textiles (Gittinger and Lefferts 1992). The region of Southeast Asia includes eleven countries: Brunei, Cambodia (Khmer), Indonesia, Malaysia, Singapore, Vietnam, Myanmar (Burma), East Timor, Laos, the Philippines, and Thailand (Siam). Its geography is composed of both mainland and insular areas. In spite of the differences in language, culture, and religion, the forms of textiles and clothing are remarkably similar.

People of mainland Southeast Asia inhabit the countries of Thailand, Cambodia, Laos, Myanmar, and Vietnam. The origins and migration patterns of these people are still debated by historians and anthropologists. Minority ethnic people who settled along the border areas of the countries are referred to as hill tribes. These hill-tribe people migrated over 1,000 years ago from the southern part of China into Laos, Myanmar, Vietnam, and Thailand. Hill tribes in Southeast Asia include Karen, Hmong (Meo), Yao, Lisu, Lahu, Lawa, Palong, Khamu, Thins, Mlabri, and Akha. Each tribe has its own distinct culture, religion, language, and arts. They make their homes in the highlands, maintaining an agricultural lifestyle and preserving their way of living with only slight changes. Both lowland and highland Southeast Asian people have created rich textiles representing their unique aesthetic in fashion and clothing.

#### Traditional Mainland Southeast Asian Clothing

Clothing forms worn in Thailand, Laos, Myanmar, and Cambodia are quite similar. Influences from India and China, carried through trade and religious teachings, are evident in clothing styles. Archaeological evidence, mural paintings, and ancient sculpture indicate that the people



**Member of Thai royal family.** The traditional dress of south-eastern Asia frequently reflects the influence of its early trading partners, China and India. © ALINARI ARCHIVES/CORBIS. REPRODUCED BY PERMISSION.

in this region were weaving textiles more than 3,000 years ago, and these textiles were often used to wrap the body. Women are depicted in both mural paintings and ancient sculptures wearing ankle-length wrapped skirts. Men are depicted wearing loincloth-type garments. A wrapping cloth could also be used to form a shawl to protect and conceal the upper body (Prangwatthanakun and Neanna 1994). It appears that wrapping styles varied depending on the occasion of wear and the activity of the person.

Traditionally, Thais and Laotians most likely used cotton for everyday wear and silk for special occasions. Wrapping cloths and ties were used in different combinations to create garment ensembles. Wrapping cloths were worn extensively despite the fact that they required more fabric than tailored apparel. An advantage was that the uncut yardage was used for many purposes, including covering for warmth, repelling mosquitoes and other insects, and as a towel for bathing.

Thai and Laotian women wore upper body wrappers, while men did not cover the upper body. Women's wrappers for the upper body provided coverage or adorn-

ment, and could also indicate social status. Typically women wore one wrapper as a covering cloth and one wrapper as decoration. The women's upper torso wrappers included breast cloths, called *pha taap*, and shoulder cloths or shawls, called *pha klum lai*. An upper torso wrapper for decoration made of pleated silk was called *sabai*.

Lower body wrappers were called *pha sin* or *pha sarong* in Thailand, and in Cambodia, *sampot*. Women usually used a piece of rectangular fabric to wrap the body, tucking in an end at the waist to form an ankle-length tube skirt. Knee-length skirts were worn for work activities such as harvesting rice. Men also wore wrapped textiles but the garment was called *pha khao ma*. Pants were also created by wrapping fabric around the body. Wrapped garments from India were the original influence for the wrapping pant. In the Sukhothai period (1238–1377 C.E.), wrapping pants, *pha chongkraben*, were adopted by Thai society from Cambodian costume.

The wrapping pant is formed with one long rectangular piece of fabric. The fabric is wrapped around the body, tied at the waist with excess fabric rolled or folded to pass between the legs from front to back where it is twisted and tucked in at the waist. A short style called *thok kamen*, typically worn by men, provided comfort and convenience when working. Women did not wear short wrappers, but typically wore garments that provided full coverage for the lower body.

Fabrics and garments symbolized social and organizational patterns that differed throughout the reign of the monarchs. A common person wore no shirt, or a shirt made of poor quality cotton with *pha chongkraben*. Fabric was plain or printed, with silk brocade worn by the wealthy. People of the upper social tiers wore elaborate, highly decorated fabrics, including brocades woven with gold or silver yarns. Special occasion fabrics—silks, satins, metallic brocades—were often imported from India and China.

High-ranking women, royalty, or nobility wore very large pieces of cloth gathered, pleated, and tucked in luxurious folds. The *pha sin* (skirt or tube skirt) was made of highly glazed cotton cloth made in India for the Thai market. The glazed finish was renewed after washing by polishing the starched cloth with a seashell (Prangwatthanakun and Neanna 1994). Children were often naked or wrapped in a length of cloth similar to adults. A child might wear a casual blouse made of woven cotton worn with a garment similar to *pha chongkraben*. Children from upper classes were adorned in elaborate, embroidered fabrics and wore ornaments such as bangles, bracelets, necklaces, ankle-lacings, and hairpins.

Cambodian men wore sarong and the women wore *sampot* with a shirt or blouse. Burmese men wore a head wrapper while wearing sarong. *Sampot* is approximately 40 inches (1 m) wide and as much as 120 inches (3 m) long. Special occasion *sampot* and sarong were woven of silk, and embroidered with gold or silver threads. *Sampot* and sarong can be worn with a long piece



of fabric gathered at the waist, passed between the legs, and tucked into the waistband in back like *pha chongkraben* worn in Thailand. Typically, Cambodian women wore dark colored (black, dark blue, or maroon) *sampot* with short-sleeved plain blouses. An essential part of Cambodian traditional clothing is the *karma*. It is a long scarf that can be worn around the neck and over the shoulders. It also can be wrapped turban-style around the head and loosely knotted. Cambodians living near the border of Vietnam adopted the Vietnamese conical hat style.

Vietnamese traditional clothing presents strong Chinese influence. The garment called *ao dai* (pronounced “*ao yai*” in the south and “*ao zai*” in the north) is a cut-and-sewn form of clothing instead of a wrapping cloth. *Ao dai* is a long body-hugging gown worn over trousers. The sheath is split at the side seam hem to provide ease of movement and comfort. Girls wear pure white *ao dai* symbolizing their purity. Soft pastel shades are worn by young, unmarried women. Married women wear gowns in strong, rich colors, usually over white or black pants. Men wear *ao dai* less often, generally only for formal ceremonies such as weddings or funerals.

Southeast Asian mainland hill-tribe people live in the mountains of China, Vietnam, Myanmar, Laos, and northern Thailand. Women are skilled in weaving, using back-strap and foot-treadle looms. Some hill tribes, like Lahu, wear clothing that protects them from the cold mountain climate and fits their active lifestyle of hunting, trapping, and riding horses. Clothing forms include high-necked, long-sleeved jackets and long trousers that fit tightly at the ankles. They also produce delicate patchwork trims and unusual embroidery work and often wear plain, simple metal jewelry.

Other hill tribes, such as Hmong, embellish their clothing with detailed embroidery and silver jewelry. Women traditionally make clothing for their families from cotton or hemp. Hmong women wear pleated skirts with intricately embroidered bands of red, blue, and white. Black satin jackets provide a somber background for the embroidered motifs. Silver ornaments are worn during ceremonies devoted to the sky spirit.

#### Historical Influences on Southeast Asian Clothing

There are four major periods of Thai history: Sukhothai, Ayuthaya, Thonburi, and Rattanakosin. The Sukhothai period (1238–1377 C.E.) exhibited a very rich culture. The country was free from serious war, agriculture developed, and food was plentiful. In this prosperous climate, craftsmanship flourished and elaborate textile techniques and styles developed. However, garment fabrics for high-ranking people were imported from China, India, and Persia. The wrapping style, *pha chongkraben*, was adopted from Cambodia during this period.

The Ayuthaya period (1357–1767) is known as the golden period of textile trade. Ayuthaya, the ancient capital city, is located 50 miles (76 km) north of Bangkok.



**Black Tai Vietnamese women.** Elaborately embroidered headwraps such as these are worn by the Black Tai, an ethnic group that lives along the Red and Black Rivers in northern Vietnam.

© CHRIS LISLE/CORBIS. REPRODUCED BY PERMISSION.

During this period Thailand was a major trading center. Agents from Holland, France, the Middle East, Persia, India, Japan, and insular Southeast Asia worked in the country to facilitate the textile trade. Fabrics were imported from many countries, including silk and satin from China, chintz from India, *pha poon* from Cambodia, and some fabrics from Europe. Fabrics used for high-ranking people were elaborate and often made to order. In contrast, textiles worn by common people were woven by villagers and exchanged in a barter system (Gittinger and Lefferts 1992).

During the Thonburi period (1767–1781), a short span of time between Ayuthaya and Rattanakosin, there was a decrease in the textile and fabric trade. Fashion and styles of the Thonburi period did not change substantially from the Ayuthaya period. The current period, Rattanakosin (1782 to present day), was established by King Rama I (1782–1809) in the royal house of the Chakri monarchy. King Rama V (1868–1910) initiated changes in clothing, and white, satin long-sleeved shirts became



**Vietnamese family.** While wrapped garments were the traditional clothing of choice on the Asian mainland for many centuries, by the early 2000s they were used primarily for special occasions, and pants, skirts, and shirts became the prevalent style. © CHRIS LISLE/CORBIS. REPRODUCED BY PERMISSION.

popular. Similar to other mainland Southeast Asian countries, westernization emerged as the prevalent style of clothing. Methods of making textiles and apparel gradually changed from handicraft to manufacturing. Plain, dark blue silk replaced traditional elaborate fabrics. Royalty dressed according to their position, with color indicating rank and status (1910–1925) (Gittinger and Lefferts 1992).

### Southeast Asian Clothing of the Twenty-first Century

Globalization and advances in technology have affected Southeast Asian society and lifestyles. High-ranking people and nobility adopted Western, tailored garments that were seen as fashionable. Although Thailand was never colonized by a European power, Western styles of clothing were readily adopted and became fashionable. Tailored garments gradually replaced wrapping cloths as the form of everyday dress. Men adopted neckties, bowties, and suit jackets if they could afford them, even though these close fitting, restricting styles are not comfortable in the tropical climate of Southeast Asia. Women transitioned from wearing the breast cloth and *pha sin* or *pha*

*chongkraben* to wearing blouses and skirts. The adaptation pace of Western clothing differs from country to country.

By the beginning of the twentieth century, tailored garments were prevalent. Traditional clothing gradually disappeared from metropolitan areas. In the twenty-first century traditional styles of clothing can be seen as special occasion dress or worn in rural areas as everyday wear. In urban areas men wear suit jackets, trousers, and shirts to the office and women wear pants, skirts, shirts, blouses, and dresses. As the popularity of traditional clothing forms decreased, efforts have been made to motivate people to wear traditional clothing. High quality textiles with traditional embroidered or printed motifs have been developed to be attractive and suitable for today's lifestyles and fashionable wrapping cloth styles are being developed to appeal to the modern consumer.

See also **Ao Dai; Textiles, Southeast Asian Mainland.**

#### BIBLIOGRAPHY

Gittinger, Mattiebelle, and Leedom Lefferts Jr. *Textiles and the Tai Experience in Southeast Asia*. Washington, D.C.: The Textile Museum, 1992.

Navikwimoon, Anak. *Ratanakosin Dress*. Bangkok, Thailand: Aksorn Sampan, 1982.

Prangwatthanakun, Songsak, and Patricia Neanna. *Thai Textiles: Threads of a Cultural Heritage*. Bangkok, Thailand: Amarin Printing, 1994.

*Uraivan Pitimaneeyakul and Karen L. LaBat*

**AUSTRALIAN DRESS** Australia was first settled by the British in the late eighteenth century. Incoming officials, convicts, and later settlers brought with them dress practices and tastes at odds with customary attire of the indigenous inhabitants. Marking the nation's early history were confused cultural interpretations between newcomers and local indigenous peoples. Given the manner in which Australia was colonized, white Australians have persistently demonstrated strong reliance on Europe, the United Kingdom, India, the United States, and, later, China, for imported clothing, textiles, stylistic concepts, and manufacturing expertise. Somewhat surprisingly the most commanding influence on early Australian fashion was from France rather than Great Britain, with a continuing record of Parisian influence on dress and millinery from at least the 1820s until the late 1950s. At the same time the sleek, functional sports and leisure wear of the United States has been a significant source of inspiration for Australian ready-to-wear designers. It is a mistake, however, to regard Australian dress as a provincial version of other countries, although there is an element of truth to this view.

While one can point to no more than a few examples of recognizably Australian garments, the identity of Australians is expressed by clothing beyond this, in a complex mix of sometimes quite subtle elements and associated behaviors that challenge accepted understandings of class. Effects of climate certainly play a part, as does the early influence of life on the land and the goldfields. But even characteristically Australian garments, such as the all-weather Dryzabone coat, are not necessarily worn nationwide; there has always been a regional component to clothes in Australia, plus a distinctive metropolitan and rural divide. Close ties with Asia and migrants including

Greeks and Muslims, with their own customary practices, add further dimensions to the picture of Australian dress. The attire of indigenous peoples, many who are disadvantaged and live in areas remote from cities, with limited capacity to purchase new clothing, add further layers of complexity to the overall picture of what people have worn, and do wear, in Australia.

#### Scholarship on Dress

Until the 1990s, the study of dress and fashion in Australia was marked by limited scholarship, one reason being the cultural disparagement of a practice traditionally associated with women's interests. Harsh environmental conditions in rural areas, especially dominated by men, meant fashionable dress was often given a low priority. Australian men have historically prided themselves on a lack of attention to the finer details of appearance, regarding this as incompatible with masculinity. While this conservatism shifted markedly with the expansion of urban living, and an increasingly materialistic social outlook after the 1980s, disparagement of clothing seems to have flowed on to a general unease about the subject of fashion itself. With some notable exceptions, such as the Powerhouse Museum in Sydney, museums and art galleries have shown little sustained interest in collecting Australian dress, especially everyday clothing. The collecting of penal clothing is one exception. All of this has lent a lack of legitimacy to the subject, something slowly being remedied as Australia gains confidence in the products of its own fashion industry and the showcasing of dress by its movie stars and sportspeople.

#### Dress and the First Australians

While colonial settlers regarded clothing as a means of displaying power and prestige, the same is not true of indigenous Australians. Various accepting and disavowing the Western clothing system, their concerns have been and are focused on community affiliation, ceremonial adornment, or political resistance. In customary life, indigenous peoples went largely unclothed, apart from kangaroo and opossum skin cloaks, marking their bodies with earth pigments, and adorning them with accessories of local fibers, shells, bark, and leaves. However, government officials, missionaries, and pastoralists sought to impose Western dress on those with whom they came in contact, using it as a technique of acculturation and frequently as a reward system. Enforced use of European dress contributed to the decline in the techniques of indigenous people for making their own garments and almost certainly contributed to their early health problems. In the early 2000s, most indigenous people wear Western-style clothing, although in remote areas, regional patterns of T-shirt, dress, and scarf-wearing are evident. Some items of Western dress, such as the Akubra hat and the knitted cap (beanie), have been incorporated into indigenous cultural tradition.

From the 1960s, the Australian government encouraged indigenous peoples to make and market their own



#### COMMENTARY ON THE DRESS OF MELBOURNE WOMEN

"I fancy that the French *modistes* manufacture a certain style of attire for the Australian taste. . . . It is a compound of the *cocotte* and the American" (Twopeny, p. 75).



fabric, T-shirt, and jewelry designs as a way of achieving self-sufficiency. From the 1980s, some practitioners became fashion designers in their own right like Bronwyn Bancroft, Lenore Dembski, and Robyn Caughlan, the first indigenous designer to show a ready-to-wear line at the Mercedes Australian Fashion Week in 2003. The work of these designers, stressing bold textile designs, offers an interesting counterpoint to modern mainstream fashion. In other examples, the successful company Balarinji, and European designers like Jenny Kee, Linda Jackson, and Peter Morrissey, have and do cooperate cross-culturally, in the latter case using textiles designed by the indigenous artist Jacinta Numina Waugh.

### Signaling Australian Identity

Since colonial times, Australian dress has been marked by strong regional differences. The dress of Sydney tends to be stylistically closer to American, with Melbourne more British and conservative, and subtropical cities like Brisbane and Perth favoring brighter, casual clothing affected mostly by the prevailing climate. Although these differences cannot be termed Australian per se, regionalism is one way that Australians define themselves. The other defining characteristic that emerged during colonial times was a supposed egalitarianism in men's dress. Associated with the dress of experienced rural "old hands," it consisted of rough rural and goldfields' attire quite different from conventional urban clothing. This comprised cabbage tree (palm-leaf) hats or slouch felt hats, later the Akubra hat, smock frocks, checked shirts, and hardwearing moleskin trousers and boots. A mythology has grown up around this masculine clothing, deeming it to be quintessentially Australian, though this has not been the case with women's dress. Companies, including RM Williams and Blundstone boots, continue to foster this mythology, and sell versions of their clothing worldwide, but nowadays to both sexes and not solely for rural wear.

A taste for Australian motifs and indigenous color schemes in dress and swimwear textiles was evident from the 1940s. But it was the 1970s that marked a particular watershed in the history of recognizably Australian fashions. Jenny Kee and partner Linda Jackson, who set up the Flamingo Park boutique in Sydney in 1973, initiated a novel style of art clothing that, among other romantic influences, later paid tribute to the native flora and fauna of Australia. It was in debt to the designs of indigenous peoples with whom they collaborated, or some would say exploited. The following decade saw a number of Australian companies achieve a degree of success in the international market. These included Coogi and Country Road, with its superior quality clothing in "natural" earthy colors, promoting so-called rural values, with outlets in the United States by 1985. The popularity of colorful, locally inspired Australiana designs, at their peak in the late 1980s, declined for everyday wear at the start of the next decade with the onset of more minimalist

tastes. Only vestiges of this linger on, mainly in garments destined for the tourist market.

### Class and Social Position

From the early years of colonization, a noticeable tension was evident in the ways settler Australians expressed social position through dress. Colonial history is rich in accounts of mistaken social identity. Some of this tension arose from problems strangers had in decoding signs of class. It also stemmed from a prevailing myth of classlessness, coupled with a correspondingly intense awareness of social position characteristic of a small population. Some of the supposed lack of class differences related to informality in social interactivities and the dominance of the open-air lifestyle; other reasons pointed to the small, sometimes inward-looking population. Yet contemporary Australians of both sexes could be said to swing from a general disinterest in high fashion, to something more like pretentious investment in stylish, even vulgar visibility, originally the result of newfound money. For instance, Australians exhibit exuberance in clothes for special events, such as weddings and attendance at race meetings, even for leisure, but at the same time favor informality of clothing and dressing down. Some of the exuberance stems from a wayward form of "larrikinism" across both sexes. This is chiefly an Australian term meaning a kind of rowdy, non-conformism, complicated by a self-conscious disinterest in accepted routines of fashionable dress and behavior.

### Clothing and Fashion Industries

Although always dependent on imported attire and fabrics, especially high-grade goods, a local clothing, footwear, and textile industry was set up in Eastern Australia soon after first settlement. These industries have been subject to a persistently troubled history, although until the mid-twentieth century, Australia sustained a sound reputation for manufacturing good-quality, comfortable clothing and textiles. Immediately after World War II, local wool fabrics were successfully promoted, initially by the Australian Wool Board and later the Australian Wool Corporation, but the situation has remained endemically volatile at the quality end of the fashion spectrum. While a fashion industry of sorts emerged by the early twentieth century, the real high point for the rag trade occurred in the decade immediately following World War II.

However, from the 1960s, Australia's textile and clothing industries started to lose what market share they had; coupled with protectionism, the mainstream industry, with some exceptions like the Prue Acton and Trent Nathan labels, began a serious decline. Chronic lack of capital, a small population, lack of ability to market high-volume goods and the steady lifting of tariffs from the late 1970s, made Australia's industries less and less competitive with imports, especially those from China. The latter became the country's main source of clothing by



**Eugene Von Guerard, Black Hill.** This 1984 watercolor is indicative of the clothing style of early Australians, where fashion was eclipsed by function. Until the late twentieth century, most Australian garments tended toward the masculine and unremarkable. LA TROBE PICTURE COLLECTION, THE STATE LIBRARY OF VICTORIA. REPRODUCED BY PERMISSION.

the 1980s. The decline in the local industry persisted. Following the worst clothing retail sales on record in 1996, the Mercedes Australian Fashion Week was inaugurated in Sydney, and the following year the first Melbourne Fashion Festival. Both were attempts to showcase Australian products and draw international buyers. While neither venture has had overwhelming success, a number of fresh, new Australian designers made a strong impact in Europe and the United States in the mid-1990s. These include Collette Dinnigan, Asian-born Akira Isogawa, who made his debut in 1996, the edgy clothing of Sass and Bide (launched in 1999), Easton Pearson, with its fusion designs combining traditional Indian and African cultures with contemporary ideas, and Morrissey (who launched solo in 1997). Despite these successes, Australian fashion remains somewhat marginalized, with its identity still under negotiation and overseas acceptance sporadic. In fact, competitive global marketing, the impression that the country is far removed from major centers of style, and its seasons out of step with the Northern Hemisphere has generally exacerbated rather than eased the industry's problems.

**Leisurewear**

Australia is not surprisingly at its most successful in the areas of leisure and beachwear. A local swimwear indus-

try can be identified early in the twentieth century, soon reinforced by the presence of American swimwear manufacturers like Jantzen and Cole of California. In 1928, the Speedo label was created, and this company went on to be one of the most successful brands of Australian swimwear, exporting to the United States by the late 1950s. Many successful mainstream designers of swimwear became household names like Brian Rochford, the Gold Coast's Paula Stafford, and Nicole Zimmermann. Perhaps more significantly, innovative youth-oriented surf-wear companies who produce brightly colored, fun-loving designs like Rip Curl, Billabong, Mambo (with its biting satirical designs established in 1984 by Dare Jennings), and Quiksilver have gone on to represent Australian style most successfully in the international arena. Indeed, a major ingredient in the pervasive view of Australia as an outdoor nation, free from constraints, is a glowing tanned body, enhanced by attractive swimwear.

See also **Ethnic Dress; Swimwear.**

**BIBLIOGRAPHY**

Fletcher, Marion. *Costume in Australia, 1788–1901*. Melbourne, Australia: Oxford University Press, 1984. First serious account of colonial dress but with an emphasis on bourgeois fashions.

Joel, Alexandra. *Parade: The Story of Fashion in Australia*. Sydney, Australia: HarperCollins, 1998. Text focused on period styles in high fashion. Of limited theoretical use. Revised, augmented edition.

Maynard, Margaret. *Fashioned from Penury: Dress as Cultural Practice in Colonial Australia*. Cambridge, U.K.: Cambridge University Press, 1994. First academic study of colonial dress across all classes.

———. "Indigenous Dress." In *Oxford Companion to Aboriginal Art and Culture*. Edited by Sylvia Kleinert and Margo Neale. South Melbourne, Australia: Oxford University Press, 2000. First nonanthropological account of the dress of indigenous Australians.

———. *Out of Line: Australian Women and Style*. Sydney, Australia: University of New South Wales Press, 2001. First comprehensive text on twentieth-century women's dress and the fashion industry in Australia, including an account of indigenous designers.

Twopeny, R. E. N. *Town Life in Australia 1883*. Sydney, Australia: Sydney University Press, 1973.

*Margaret Maynard*

**AVEDON, RICHARD** Richard Avedon (b. 1923) was one of the most important and prolific photographers of the second half of the twentieth century, and in the eyes of many photography and fashion specialists, he was the most important fashion photographer of all time. In a career spanning sixty years he showed himself capable of almost constant stylistic reinvention, yet in retrospect his oeuvre also demonstrated a remarkable coherence and strength that far surpassed the narrow confines of fashion photography. He was acknowledged by his peers for his superb work as early as 1950, when he won the Highest Achievement Medal of the Art Directors Club in New York. Only eight years later he was named by *Popular Photography* magazine as one of the ten most important photographers in the world. By the end of the twentieth century, having garnered handfuls of honorary degrees, lifetime achievement awards, and other prestigious prizes, Avedon was identified by the *Photo District News* as "the most influential photographer of the past twenty years." These successes were due in no small measure to his acute sensitivity to the social and artistic revolutions in American culture. As the historian Nancy Hall-Duncan observed in 1979, "This sense of timing and flexibility—representing the desires of our society and reflecting its mood with uncanny sympathy—was Avedon's forte from the start of his career." This talent also helps to explain why he was never displaced by a younger pretender, as happened to so many of his rivals. John Durniak once reported in *Time* magazine that an admiring colleague considered Avedon "the white mechanical rabbit that all other photographers tried to catch" but never could. Even allowing for the hyperbolic language of the fashion industry itself, which anointed him the king of fashion photography, Avedon could claim a towering record of achievement.

Richard Avedon was born in New York City, the son of Russian Jewish immigrants who owned a department store in Manhattan. His school years revealed a marked literary aptitude: he was coeditor with James Baldwin of the De Witt Clinton High School literary magazine, and he was named poet laureate of the New York City high schools in 1941. A brief period of study in philosophy at Columbia University was followed by two years in the U.S. Merchant Marine (1942–1944), after which Avedon undertook intensive visual studies with Alexey Brodovitch at the Design Laboratory of the New School for Social Research. New York had everything the ambitious young man wanted: "theater, movies, music, dance." Part of Avedon's visual education had come from his love of photography. As a teenager he had decorated his room with the work of the masters; as a mature professional, he benefited from the lessons of his predecessors. This keen awareness of the accomplishments of previous artists in the field, and a philosophical bent that allowed him to consider the medium of photography in abstract as well as practical terms, encouraged him to explore the full gamut of the medium's possibilities. For example, switching to a large-format camera after he had started his career in fashion photography with the more flexible Rolleiflex made him realize that throwing the background of a shot out of focus reduced the sum of detail and created "an ambiguous narrative relationship between the knowable (what's sharp), and the unknowable (what's blurred)" (Thurman and Avedon).

Avedon's arrival on the scene coincided with the final years of the dominance of haute couture. In 1945 Carmel Snow invited him to join *Harper's Bazaar* as staff photographer, where his mentor Brodovitch was already working as art director. Avedon thus stepped into the shoes (but not the footsteps) of the great neoclassicist image-maker George Hoyningen-Huene, who was convinced high fashion was dead. Hoyningen-Huene greeted his young rival disdainfully with the phrase, "Too bad ... Too late!" It was this atmosphere of ennui that Snow wished to dispel in and with her magazine. The visionary editor wanted to reinvigorate the Parisian luxury business by opening the vast American market to it, and she needed an interpreter of French taste who was less aloof than Hoyningen-Huene—someone who could temper the classicism of French couture with American zest.

It was not surprising that Avedon always acknowledged the Hungarian photojournalist-turned-fashion photographer Martin Munkacsy, rather than the patrician Hoyningen-Huene, as a key influence on his style. Munkacsy was a pioneer of the out-of-doors realistic fashion photograph, a major stimulus to Avedon's own approach, although the fact that Avedon skillfully combined the exuberance of outdoor photography with the static tradition of the studio showed that he had absorbed lessons from the Baron Adolf de Meyer, Edward Steichen, and George Hoyningen-Huene as well.



For the next four decades Avedon's name was synonymous with the best of fashion photography. Between 1947 and 1984 he photographed the Paris collections for either *Harper's Bazaar* or *Vogue*, and he worked exclusively for the latter from 1966 to 1990. Avedon preferred to work repeatedly with the same models, establishing a rapport that, in his words, was "built from sitting to sitting and from season to season." Whether the sitter was Suzy Parker wearing Gres, Dovima wearing Dior—"Dovima Among the Elephants" (1955) is arguably Avedon's most famous photograph—or Jean Shrimpton and Veruschka dressed in psychedelic whimsies, the models wore the clothes as if they were born to them. Avedon's earliest photographs showed women dancing, partying, skipping about from one lively *boîte* to another on the arm of debonair escorts, the images always striking a careful balance between factual information about the dresses and impressions of how the women looked—and more important, it was implied, felt—wearing them. Despite the seemingly spontaneous character of the images, however, the photographer carefully researched his outdoor and indoor settings before he undertook the sittings.

Avedon's intense early commitment inevitably took its toll. After twenty years in fashion photography, he decided that there was "too much narcissism and disenchantment" in the work. The outdoor images gave way to a harsher minimalist aesthetic that was even described as "cruel," the fabrication of which was possible only in the studio. "I've worked out a series of no's," Avedon wrote in 1994, "... no to exquisite light, no to apparent compositions, no to the seduction of poses or narrative. And all these no's force me to the yes. I have a white background. I have the person I am interested in and the thing that happens between us." If he continued to work in the arena of fashion, it was to support his family and his "art"—namely, portrait photography.

Avedon's sitters essentially comprised a gallery of the rich, the famous, and the powerful. All were treated equally, in such a way that fellow photographer Henri Cartier-Bresson could call them "inhabitants of an Avedon world." Avedon's twentieth-century gallery has been acknowledged as one of the greatest projects of its kind—in historian and curator Maria Hambourg's words, "a gallery of modern souls as intense and vivid as any ever achieved." Yet somehow, the portraits in the aggregate comprised Avedon's self-portrait, or as Thomas Hess wrote, Avedon seemed always to be "trying to climb into his image." After 1990, his portraits of the past and the present were regular features of the *New Yorker* magazine. Avedon's work was also exhibited in such prestigious institutions as the Metropolitan Museum of Art, the Smithsonian Institution, the Museum of Modern Art in New York, the Minneapolis Institute of Fine Arts, the Seibu Museum in Tokyo, the Museum "La Caixa" in Barcelona, and the University Art Museum in Berkeley, California.



**Richard Avedon and model.** Avedon's prestigious career spanned sixty years, during which he garnered numerous awards and was referred to by many as the "king of fashion photographers." THE LIBRARY OF CONGRESS. PUBLIC DOMAIN.

See also **Celebrities; Fashion Museums and Collections; Fashion Photography; Hoyningen-Huene, George; Vogue.**

**BIBLIOGRAPHY**

- Avedon, Richard. "The Family." Special bicentennial issue of *Rolling Stone*, 21 October 1976.
- . *Photographs 1947–1977*. New York: Farrar, Straus and Giroux, 1978.
- . *In the American West 1979–1984*. New York: Harry N. Abrams, Inc., 1985.
- . *Evidence 1944–1994*. New York: Random House, 1994.
- . *Portraits*. New York: Metropolitan Museum of Art and Harry N. Abrams, Inc., 2002.
- Avedon, Richard, and Truman Capote. *Observations*. New York: Simon and Schuster, 1959.
- Avedon, Richard, and Arbus Doon. *The Sixties*. New York: Random House, 1999.
- Baldwin, James, and Richard Avedon. *Nothing Personal*. New York: Dell Publishing Company, 1964.
- Thurman, Judith, and Richard Avedon. *Richard Avedon: Made in France*. San Francisco: Fraenkel Gallery, 2001.

*William Ewing*



**BALENCIAGA, CRISTÓBAL** Born in 1895 in Guetaria (Getaria), a small fishing village on the tempestuous northern coast of Spain, Cristóbal Balenciaga Eisaguirre (1895–1972) was to become, in his own lifetime, the most famous Spanish fashion designer of his generation. He died in the mellower climate of Jávea, on the eastern coast of Spain, twelve years after receiving the Légion d'honneur for services to the French fashion industry and only four years after closing down his prestigious business in Paris. The contrast between Balenciaga's places of birth and death offers a touching analogy to his journey from rags to riches or, at the very least, from a relatively obscure, fairly modest, and extremely hardworking provincial background to the sunny prominence of an established position in international fashion. While he gained considerable material comfort, he did not lose his work ethic. He owned a flat in central Paris, an estate near Orléans (France), and a substantial house in Igueldo, near Guetaria. He was able to fill his homes with collections of decorative and fine arts and, from time to time, with friends from different walks of life.

Balenciaga evidently achieved this major change in circumstance, initially, through the patronage of a member of the Spanish aristocracy, the marquesa de Casa Torres, who recognized his talent at sewing—a skill learned from his seamstress mother—and apprenticed him to a tailor in fashionable San Sebastián (Donostia). From this training, he went on to become chief designer in a local dressmaking establishment, before opening his own house in Madrid. Armed with financial backing from a fellow Basque, he subsequently successfully established, directed, and designed for the Parisian couture house that bore his name. At the same time, he maintained three high-class dressmaking establishments in Spain, in San Sebastián, Barcelona, and Madrid. They functioned under the label *Eisa*, an abbreviated form of his mother's patronymic.

Balenciaga's formative experiences in Spain were fundamental to both his design practice and his ultimate move to Paris. His tailoring apprenticeship gave him a mastery of cut and construction and an obsession with perfection of fit. He was one of the few couturiers who was capable of "cutting material, assembling a creation and sewing it by hand," as even his archrival Coco Chanel acknowledged (Miller, p. 14). His fascination with cer-

tain simple forms (the manipulation of circles, semicircles, and tunics) may well have derived from familiarity with the cut of the ecclesiastical vestments and clerical dress so common in Spain. His use of certain colors (black, shades of gray, earth colors, brilliant reds, fuchsia, and purple), certain forms of decoration (heavy embroidery and braid), and certain fabrics (lace used voluptuously in flounces and heavy woolens or new synthetics "sculpted" into extraordinary shapes) owed much to the aesthetic of Spanish regional dress and to the drapery and costume depicted in Spanish painting and sculpture from 1500 to 1900. His early working experience in San Sebastián alerted him to the dominance of Paris in international women's fashion, as one of his responsibilities was to travel to the center of couture to the seasonal collections, to make drawings of models that might subsequently be translated into garments for Spanish clients. In this second, transitional, stage of his career, he was copyist or translator rather than originator of designs.

### Historical Context

While the reasons for Balenciaga's departure from Spain in 1935 at the age of forty, and his subsequent establishment in Paris, are not clear, it is probable that the commercial and political situation in Europe contributed to his move. In the 1930s Paris was the fashion mecca not only for ambitious designers but also for the cosmopolitan women they dressed. The French government fostered couture and its ancillary trades because they were important national export industries. Subsidies encouraged the use of French textiles, and textile manufacturers supplied short runs of rare fabrics for couture collections. The trade organization *Chambre Syndicale de la couture parisienne* guided the regulation of conditions of employment, training for prospective couturiers, and the efficient coordination of the twice-yearly showings of all couturiers' collections. This arrangement made the trade desirable, as private clients and commercial buyers from department stores and wholesale companies from other parts of Europe, the United States, and Japan could plan their visits in advance and make the most of their time in Paris. Before World War II, no other country boasted such a highly organized and prestigious fashion system, a fact of which Balenciaga must have been aware as early as about 1920.



**Woman modeling Balenciaga coat and dress.** This ensemble smartly conveys several Balenciaga trademarks, such as elegance and grandeur, monochromatic colors, and a perfect fit. HENRY CLARKE/VOGUE © 1995 CONDÉ NAST PUBLICATIONS, INC. REPRODUCED BY PERMISSION.

That Balenciaga chose to “defect” some fifteen years later was probably linked to the increasingly difficult political situation in Spain, a state of affairs that did not bode well for those who made their living from fashion. In 1931 the Spanish monarchy fell, and a period of uncertainty preceded the Spanish Civil War (1936–1939). Balenciaga lost his main clientele of the 1920s, the Spanish royal family and the aristocracy who summered in San Sebastián and wintered in Madrid. Consequently, he

closed down his branch in the north of Spain just after it opened. The advent of war did not improve his prospects, so his move to Paris (via London) was timely. By 1939, when he reopened his houses in Spain, he had made a reputation in Paris, gaining an international clientele that far outstripped the captive following he had had in Spain.

During World War II, he moved back and forth between the two countries, keeping a connection with his familial and cultural roots and control of his modest fash-



ion empire. At the end of the war he continued this practice. Even when he spent long periods in Paris, he did not lose contact with Spaniards, as both his business and home were in the district frequented by Spanish émigrés, many of his business associates or employees were Spanish, and his friends included his fellow countrymen the artists Pablo Picasso, Joan Miró, and Pablo Palazuelo.

### The Businesses

Haute couture businesses are secretive about their internal workings, if not their ambitions, and often it is the design records rather than the accounts that survive. In the absence of financial or administrative archives for the house of Balenciaga, it is possible to reconstruct its organization and strategy only through its public registration, its rich design archive, and limited oral and written testimony from the salon, some of the more illustrious members of its clientele, and a few of the designer's colleagues or pupils. Tradition and continuity were particular characteristics of the house, in terms of its internal structure and workforce, its design output and quality of production, and its maintenance of a faithful and prestigious customer base. Gimmickry was avoided at all costs—even in the postwar period of consumerism, when many of Balenciaga's competitors engaged freely in a variety of new sales tactics, including the development of ranges of ready-to-wear clothing, accessories, and numerous fragrances and the use of advertising.

As was relatively common in Parisian couture, Balenciaga was a limited company, in the form of a partnership between Balenciaga himself, his hat designer and friend Vladzio Zawrorowski (d. 1946), and Nicolas Bizcarrondo, the Basque businessman who provided the initial capital. Balenciaga's previous success in Spain and the existence of three houses there (albeit that they were in limbo in 1937) might well account for Bizcarrondo's faith in Balenciaga and his willingness to support him. Established in 1937 on an initial investment of Fr 100,000, the value of Balenciaga's couture house rose to Fr 2 million in 1946 and to Fr 30 million in 1960. Injections of funding coincided with expansion in its activities. The investment reflected the size—large by couture standards but small relative to industrial enterprises before or after World War II.

The structure of the design house followed to the letter a traditional couture model, conforming without difficulty to the new haute couture regulations implemented in 1947. Throughout Balenciaga's reign, the seat of business was at 10 avenue Georges V—a suitable location in the golden triangle of Parisian luxury production. This six-story building served all functions—esthetic, craft, commercial, and administrative. Discretion was the key to both the exterior and interior, with little overt reference to the house's sales function. On the outside, classical pillars flanked the shop windows, which never contained any hint of clothes for sale but rather pretended to a certain artistry.

On the ground floor the entrance was through the boutique (shop), which stocked accessories, such as gloves, foulards, and the perfumes *Le Dix* (1947), *La Fuite des Heures* (1948), and *Quadrille* (1955). This floor had the appearance of the hallway of a grand house, with a black-and-white tiled floor, rich carpets, and dark wooden and gilded furniture and fittings. On the first floor, reached by an elevator lined in red Cordoban leather and studded with brass pins, were the salon and fitting rooms, decorated in 1937 in the fashionable Parisian taste of the day, with upholstered settees, curvaceous free-standing ashtrays, and mirrored doors. Presided over by Madame Renée, this floor was home to the *vendeuses* (saleswomen), who greeted their own specially designated clients, consulted with them about their vestmental needs and social calendar, introduced them to the models that might suit them (specially paraded by a house mannequin), and then watched over their three fittings once they had placed their orders. Above the salons were the workshops where the clothes were cut and constructed; only occasionally were certain garments farmed out for special treatment, for example, to the embroidery firms of Bataille, Lesage, or Rébé for embellishment. Higher still in the building were the offices occupied by the administration.

**Expansion and continuity.** Workshop space expanded beyond the four workshops set up in 1937 (two for dresses, one for suits, and one for dresses and suits). During the war (1941) Balenciaga added two millinery ateliers; then, after the war (1947–1948), another two workshops for dresses and one for suits; and, finally, in 1955, another for dresses, bringing the total to ten. Just before the opening of the final workshop, Balenciaga's employees numbered 318. In the scheme of things, Balenciaga valued his cutters more highly than his workshop heads, paying the former 20–30 percent more than the latter between 1953 and 1954. Given the reputation of the house for high-quality tailoring, this prioritization is not surprising, nor is the fact that skilled employees in positions of trust remained with the firm over a prolonged period. In the case of the known workshop heads, the majority stayed for twenty to thirty years. Moreover, “new” senior staff members seem to have arrived from the Spanish houses, possibly because Balenciaga could rely on their standards and experience.

### Client Base

Continuity was also an aspect of the client base, satisfying Balenciaga's firm belief that women should find and remain with the dressmaker who best served their needs and understood their personal styles. Many private and professional clients patronized the house for thirty years. At his height, Balenciaga showed his collections to two hundred wholesale buyers and made to measure about 2,325 garments per annum for private clients. Some of the latter bought as many as fifty to eighty items per year.

They made their choices from the four hundred models he created, a number in line with the output of other top couturiers of the time.

Major department stores bought Balenciaga models with particular customers in mind and then reproduced as closely as possible the couture experience in their salons, offering fashion shows, personal advice on customers' social and practical needs, and high standards of fitting and making. At different times these firms included Lydia Moss, Fortnum and Mason, and Harrods in London; Hattie Carnegie, Henri Bendel, Bloomingdale's, Saks Fifth Avenue, and Bergdorf Goodman in New York; I. Magnin in Los Angeles and San Francisco; and Holt Renfrew in Toronto. In contrast, wholesalers bought with batch production in mind, spreading Balenciaga styles through their adaptation of toiles from the house. The wholesalers who attended Balenciaga's shows included many members of the London Model House Group, the elite of ready-to-wear. For them, every model had about eight to ten derivatives, each of which was reproduced four hundred to five hundred times. Some Balenciaga models, however, were considered too complex for reproduction, whether in department stores or factories, and too outré for the tastes of more conservative clients.

Balenciaga's loyal band of private clients belonged to the wealthiest titled and untitled families across the globe and embraced both professional women and socialites. Some customers combined buying from him with purchases from other made-to-measure or ready-made sources or found his garments in special secondhand outlets. His true devotees developed a close relationship, even friendship, with "The Master," who provided for their every need: some daughters followed their mothers into the house, among them the future Queen Fabiola of Belgium, daughter of his patron, the marquesa de Casa Torres; Sonsoles, daughter of his most consistent client, the marquesa de Llanzol; and General Francisco Franco's wife and granddaughter, whose wedding dress was the last designed by Balenciaga. Others grew into Balenciaga through familiarity with his house in Paris, for example, Mona Bismarck, widow of Harrison Williams, one of the wealthiest men in America, who consistently acquired her wardrobe from him every season for twenty years, even the shorts she wore for yachting or gardening. Perhaps, like Barbara "Bobo" Rockefeller, she believed that a Balenciaga dress gave its wearer a sense of security. A cheaper way of buying made-to-measure Balenciaga fashions was open to those who knew his Spanish operations, where labor costs were lower and local fabrics sometimes were substituted for those used in Paris (and a favorable exchange rate prevailed for most foreign visitors). The film star Ava Gardner, a regular visitor to Spain in the 1950s, patronized Eisa, for example, as well as the Parisian house.

Balenciaga's final—and perhaps most intriguing—client was Air France. In 1966 the world's biggest air-

line asked him to design air stewardesses' summer and winter uniforms to a brief that probably appealed to him: "elegance, freedom of movement, adaptability to sudden changes of climate, and maintenance of a smart appearance even after a long journey" (Miller pp. 57–59). His experience of dealing with the *soigné* jet set and his fashion philosophy of practicality prepared him well for this request.

### Fashion Philosophy and Signature Designs

Balenciaga was reticent in talking about himself and his craft, so the nature of his business, the identity of his clients, and actual surviving garments and designs are necessary to supplement his occasional observations about his fashion philosophy. Evolution rather than revolution, elegance and decorum rather than novelty and flash-in-the-pan fashion, practicality, wearability, and "breathability" were guiding principles in his design and, no doubt, suited a discerning, largely mature clientele. At his apogee in the 1950s and 1960s Balenciaga created designs that bear witness to his keen attention to the effects achieved by combining different colors and textures. Often the intrinsic qualities of fabrics, whether traditional woolens and silks or innovative synthetics, led the design process, as Balenciaga pondered their potential in tailored, draped, or sculpted forms. He was prepared to forgo the French government subsidy, granted to couturiers whose collections comprised 90 percent French-made textiles, in order to acquire the best-quality and most groundbreaking textiles from whichever part of Europe they came.

Balenciaga gradually honed his design in daywear, building out from the base of apparently traditional tailored suits with neat, fitted bodies and sleeves that sat perfectly at the shoulder into experimentation that led to the minimalist "no-seam coat" (1961), crafted from a single piece of fabric by the artful use of darts and tucks. This garment hung loose on the body and embodied the culmination of a range of loose or semifitted lines in various garments that probably constituted Balenciaga's most important contribution to fashion. These designs emerged gradually during the 1950s, flattering different female figures (mature and youthful) and allowing the wearer to move easily. The tunic (1955), chemise or sack (1957), and Empire styles (1958) drew attention away from the natural waist through the creation of a tubular line or the emphasis that a bloused back laid on the hip line or that a high waist laid on the bust. Suit jackets were judiciously cut, and their matching skirts were often gathered slightly into the waistband at the front to accommodate middle-age spread. Three-quarter- and seven-eighth-length sleeves and necklines set away from the neck sought to flatter the wrists and the neck, both graceful at any age. They also proved practical for busy lifestyles. In the 1960s a range of different lengths and fits of jackets and coats featured in Balenciaga's collections, from the very fitted to the loose.

Similar paring down is evident in Balenciaga's cocktail and evening wear; so, too, is a taste for the grandeur and elaboration appropriate to the purpose. For these gowns he drew on historical and non-European sources and sought his own version of modernism. Initially, for all their apparent ease, these dresses were often built on a corset base with boning, an understructure that was not obvious under the complex confections of drapery, puffs, and flounces popular in the 1950s. By the 1960s, however, shapes simplified and did not cling to or mold the body. The contrast between the slim black sheaths of the late 1940s and early 1950s and the outstanding models of gazar, zibeline, faille, and matelassé of the 1960s is absolute. The former took their drama from the swathes of contrasting satin in jewel colors that were attached at waist or neckline and could be draped to the wearer's fancy. The latter relied for their éclat on the sculptural simplicity of their lines and the substance of the fabric rather than on artificial flowers, feathers, or polychrome embroidery. While three-dimensional decoration was not obsolete, the shapes to which it adhered became tunic-like. The frills, ballooning skirts, and sack backs had given way to a more austere, almost monastic aesthetic.

### Importance and Legacy

The fashion cognoscenti, from couturiers to journalists, still accord Balenciaga the laurel of the "designers' designer." They use his name to evoke certain standards in fashion—evolution in style, ease of dress, and meticulous attention to detail (visible or otherwise). Balenciaga's former apprentices (André Courrèges and Emanuel Ungaro), colleagues (Hubert de Givenchy), and aficionados (Oscar de la Renta and Paco Rabanne) have inherited and propagated certain elements of his philosophy and style. In the last quarter of the twentieth century approximately eight major exhibitions worldwide perpetuated his fame, many facilitated by the archivist of the house of Balenciaga, owned by Bogart perfumes from 1987 to 2001 and since then by the Gucci Group (91 percent) and the in-house designer, Nicolas Ghesquière (9 percent). Ghesquière's widely acknowledged talent and vitality revived the fortunes of Balenciaga in the late 1990s, and by the early 2000s the designer himself had begun to explore the riches of the archives and appreciate more fully the shadow in which he labored. He was quick to draw parallels between his own work and that of the "The Master," although couture represents a tiny element of his output.

In Spain, Balenciaga's reputation contributed to initiatives to encourage the Spanish fashion industry: in 1987 the Spanish Ministry of Industry and Energy named the first (and only) national prize for fashion design after him and in 2000 injected \$3.2 million into the charitable foundation set up in Guetaria in his name. The overall objective of this trust is "to foster, spread and emphasize the transcendence, importance, and prominence that Don Cristóbal Balenciaga has had in the world of fashion," (www.fundacionbalenciaga.com) an objective

that is meant to be achieved through the construction and development of a museum in Guetaria, the establishment of an international center for design training, the foundation of a research and documentation center, the publication of a fashion periodical, and the development of touring exhibitions about Balenciaga, fashion design, and haute couture.

With such sustained efforts at maintaining Balenciaga's reputation and values, his impact on fashion is bound to survive, disseminated through a range of techniques from which the reserved and publicity-shy Balenciaga himself might well have recoiled. The ramifications of his dedication to fashion for that once small fishing town of Guetaria are likely to be impressive.

*See also* **Chanel, Gabrielle (Coco); Courrèges, André; Ecclesiastical Dress; Haute Couture; Paris Fashion; Spanish Dress.**

### BIBLIOGRAPHY

- Ballard, Bettina. *In My Fashion*. New York: D. McKay Company, 1960. A contemporary fashion editor's autobiography, which incorporates substantial portraits of many Parisian couturiers, including Balenciaga, whom the author knew well.
- Beaton, Cecil. *The Glass of Fashion*. Garden City, N.Y.: Doubleday, 1954. The fashion world seen through the eyes of the society fashion photographer Cecil Beaton, a friend of Balenciaga's.
- Bertin, Célia. *Paris à la Mode: A Voyage of Discovery*. Translated by Marjorie Deans. London: V. Gollancz, 1956. A contemporary view of haute couture and its main protagonists.
- De Marly, Diana. *The History of Haute Couture, 1850–1950*. New York: Holmes and Meier, 1980. Classic overview of the development of French haute couture.
- Jouve, Marie-Andrée. *Balenciaga*. Text by Jacqueline Demornex. New York: Rizzoli International, 1989. The first major account of Balenciaga from the archivist of the house, with superb illustrations.
- . *Balenciaga*. New York: Universal/Vendome, 1997. A brief and useful introduction to Balenciaga, largely through images but also containing new data on clients.
- Latour, Anny. *Kings of Fashion*. Translated by Mervyn Savill. New York: Coward-McCann, 1958. A contemporary fashion journalist's investigation of haute couture and its main protagonists.
- Menkes, Suzy. "Temple to a Monk of Fashion: Museum to Open in Basque Designer's Birthplace." *International Herald Tribune*, 23 May 2000. An overview of the Fundación Balenciaga in Guetaria.
- Miller, Lesley Ellis. *Cristóbal Balenciaga*. New York: Holmes and Meier, 1993. A historically contextualized account of the man and his background, clothes, clients, business, and legacy.
- Palmer, Alexandra. *Couture and Commerce: The Transatlantic Fashion Trade in the 1950s*. Vancouver, Canada: University of British Columbia Press, 2001. A multidisciplinary ap-



proach to haute couture that unpacks many of its myths by delving into the dissemination of haute couture through transatlantic (especially Torontonians) outlets, the uses and meanings of couture clothing to clients (achieved through oral history), and the examination of objects in the Royal Ontario Museum's textile collection. Useful references to the reception of Balenciaga's designs.

Spindler, Amy M. "Keys to the Kingdom: A Fashion Fairy Tale Wherein Nicolas Ghesquière Finally Inherits the Throne." *New Yorker*, 14 April 2002, pp. 53–58. Ghesquière encounters the Balenciaga archives at last.

#### *Exhibition Catalogs*

Cristóbal Balenciaga. Tokyo: Fondation de la Mode, 1987.

de Petri Stephen, and Melissa Leventon, eds. *New Look to Now: French Haute Couture 1947–1987*. New York: Rizzoli International, 1989. A case study of haute couture and its San Francisco customers, with an excellent essay explaining how department stores adapted garments for their clients.

Ginsburg, Madeleine, comp. *Fashion: An Anthology by Cecil Beaton*. London: Victoria and Albert Museum, 1971. A short section of catalog entries on the Balenciaga clothes lent to the exhibition.

Healy, Robyn. *Balenciaga: Masterpieces of Fashion Design*. Melbourne, Australia: National Gallery of Victoria, 1992. An overview of Balenciaga and his oeuvre and its importance.

Jouve, Marie-Andrée. *Homage à Balenciaga*. Lyons, France: Musée Historique des Tissus, 1985. Emphasis on Balenciaga's relationship to the textile industry.

———. *Mona Bismarck, Cristobal Balenciaga, Cecil Beaton*. Paris: Mona Bismarck Foundation, 1994. An intriguing glimpse into the relationship of a major client, her couturier, and their mutual friend. Well-documented record of designs chosen and worn by Bismarck.

*El mundo de Balenciaga*. Madrid: Palacio de Bellas Artes, 1974.

Vreeland, Diana, curator. *The World of Balenciaga*. New York: Metropolitan Museum of Art, 1973.

#### *Internet Resources*

Cristóbal Balenciaga Fundazioa-Fundación. Available from <<http://www.fundacionbalenciaga.com>>. General information on the aims and objectives of the trust and the temporary displays of clothes.

Lesley Ellis Miller

**BALL DRESS** Ball dress is simply defined as a gown worn to a ball or formal dance. Beyond this fundamental description, there are remarkably intricate conventions related to appropriateness of ball dress. The most extravagant within the category of evening dress, a ball gown functions to dazzle the viewer and augment a woman's femininity. Ball gowns typically incorporate a low décolletage, a constricted bodice, bared arms, and long bouffant skirts. Ball gowns are visually distinguishable from other evening gowns by their lavishly designed

surfaces—with layers of swags and puffs and such trim details as artificial flowers, ribbons, rosettes, and lace.

Additionally, ball gowns permit a woman to inhabit more space, as the especially billowing and expansive skirts extend the dimensions of her body. Fabric surfaces vary from reflective to matte, textured to smooth, and soft to rigid. Through the decades, undergarments have played a vital role in reshaping the natural structure of the body into the desired silhouette, from the corsets and petticoats of the nineteenth century to the control-top panty hose and padded bras of the twenty-first century.

#### **Historical Significance**

Balls have existed for centuries among royalty and the social elite, dating back to the Middle Ages. During the mid-1800s, the ball re-emerged as a desirable manner of entertainment among the upper and middle classes. Through the 1800s, the ball served as a means to bring together people of similar social backgrounds, often for purposes of introducing young women and men of marriageable age. Coming-out balls, debutante balls, or cotillion balls became standard events by the mid-1800s, and have continued in some form or another into the twenty-first century, with the high school prom added as a more middle-class and democratized version of a coming-out ball.

As popularity of the ball increased, ball gowns materialized and developed as a category of evening dress. Fashions during the first half of the nineteenth century included expansive skirts and tiny waistlines, and these characteristics were incorporated into the ball dress. Bouffant skirts functioned beautifully in the ballroom, as women skimmed across the floor as if they were floating on air. At all social levels and through the decades competition for the most opulent gown has remained a central ingredient of the event, as the finest ball gown may possibly result in the attentions of the most eligible suitor.

#### **Contemporary Use**

As the most splendid among evening dresses, ball gowns represent the romantic dreams of young women. *Cinderella* and *Beauty and the Beast* are recognizable fairy tales that instill in children the magnificence and fantasy of the ball, complete with appropriate full-skirted gown and a handsome prince. These ideas are reinforced and incorporated into our cultural consciousness. The profile of the traditional ball gown is evident in gowns for such modern-day events as weddings (bride and bride's attendants), high school proms, and the most elegant of evening occasions. Not surprisingly, designers of contemporary ball gowns continue to emphasize feminine curves while at the same time drawing from the nostalgic styles of expansive and lavishly decorated skirts, thereby establishing the wearer as a work of art.

*See also Evening Dress.*



**Designer Madame Lucille fitting ball gown.** Lavish works of fashion art, ball gowns are designed to emphasize femininity by drawing attention to the wearer's décolletage, bare arms, and small waist. © HULTON-DEUTSCH COLLECTION/CORBIS. REPRODUCED BY PERMISSION.

#### BIBLIOGRAPHY

Boucher, François. *20,000 Years of Fashion: The History of Costume and Personal Adornment*. New York: Harry N. Abrams, 1987.

Laver, James. *Costume and Fashion: A Concise History*. London: Thames and Hudson, 1982.

Milbank, Caroline Rennolds. *New York Fashion: The Evolution of American Style*. New York: Harry N. Abrams, 1989.

Payne, Blanche, Geitel Winakor, and Jane Farrell-Beck. *The History of Costume*. 2nd ed. New York: HarperCollins, 1992.

## BALLET COSTUME

Russell, Douglas A. *Costume History and Style*. New Jersey: Prentice-Hall, 1983.

Steele, Valerie. *Women of Fashion: Twentieth-Century Designers*. New York: Rizzoli International, 1991.

———. *Fifty Years of Fashion*. New Haven, Conn., and London: Yale University Press, 2000.

———. *The Corset*. New Haven, Conn., and London: Yale University Press, 2001.

Watson, Linda. *Vogue: Twentieth Century Fashion*. London: Carlton Books Ltd., 1999.

Jane E. Hegland

**BALLET COSTUME** Ballet costumes constitute an essential part of stage design and can be considered as a visual record of a performance. They are often the only survival of a production, representing a living imaginary picture of the scene.

### Renaissance and Baroque

The origins of ballet lie in the court spectacles of the Renaissance in France and Italy, and evidence of costumes specifically for ballet can be dated to the early fifteenth century. Illustrations from this period show the importance of masks and clothing for spectacles. Splendor at court was strongly reflected in luxuriously designed ballet costumes. Cotton and silk were mixed with flax woven into semitransparent gauze.

From the beginning of the sixteenth century, public theaters were being built in Venice (1637), Rome (1652), Paris (1660), Hamburg (1678), and other important cities. Ballet spectacles were combined in these venues with processional festivities and masquerades, as stage costumes became highly decorated and made from expensive materials. The basic costume for a male dancer was a tight-fitting, often brocaded cuirass, a short draped skirt and feather-decorated helmets. Female dancers wore opulently embroidered silk tunics in several layers with fringes. Important components of the ballet dress were tightly laced, high-heeled and wedged boots for both dancers, which constituted characteristic footwear for this period.

From 1550, classical Roman dress had a strong influence on costume design: silk skirts were voluminous; positioning of necklines and waistlines and the design of hairstyles were based on the components of everyday dress, although on the stage key details were often exaggerated. Male dancers' dresses were influenced by Roman armor. Typical colors of ballet costumes ranged from dark copper to maroon and purple. A more detailed description of the theatrical dress in the Renaissance and Baroque periods may be found in Lincoln Kirstein's *Four Centuries of Ballet* (1984, p. 34).



**Prima ballerina Anna Pavlova.** Early ballerina skirts were heavy, voluminous affairs that severely restricted the dancer's movements. Fortunately, by the early twentieth century, skirts were raised to the knees to showcase pointe work. © ARCHIVO ICONOGRAFICO, S.A./CORBIS. REPRODUCED BY PERMISSION.

### Seventeenth Century

From the seventeenth century onward, silks, satins, and fabrics embroidered with real gold and precious stones increased the level of spectacular decoration associated with ballet costumes. Court dress remained the standard costume for female performers while male dancers' costumes had developed into a kind of uniform embellished with symbolic decoration to denote character or occupation; for example, scissors represented a tailor.

The first Russian ballet performance was staged in 1675, and the Russians adopted European ballet designs. Although costumes for male performers permitted complete freedom of movement, heavy garments and supporting structures for female dancers did not allow graceful gestures. However, male dancers *en travesti*, often wore knee-long skirts. The luxuriously decorated costumes of this period reflected the glory of the court;



details of dresses and silhouettes were exaggerated to be visible and identifiable to spectators viewing from a distance.

### Eighteenth Century

From the early eighteenth century, European ballet was centered in the Paris Opéra. Stage costumes were still very similar in outline to the ones in ordinary use at Court, but more elaborate. Around 1720, the *panier*, a hooped petticoat, appeared, raising skirts a few inches off the ground. During the reign of Louis XVI, court dress, ballet costumes, and fashionable architectural design incorporated decorative rococo prints and ornamental garlands. Flowers, flounces, ribbons, and lace emphasized this opulent feminine style, as soft pastel tones in citron, peach, pink, azure, and pistachio dominated the color range of stage costumes. Female dancers in male roles became popular, and, after the French Revolution in 1789 in particular, male costumes reflected the more conservative and sober Neoclassical style, which dominated the design of everyday fashionable dress. However, massive wigs and headdresses still restricted the mobility of dancers. In the eighteenth and nineteenth centuries, Russian ballet and European ballet developed similarly and were often considered an integral part of the opera.

### Nineteenth Century

From the early nineteenth century, the ideals of Romanticism were reflected in female stage costumes through the introduction of close-fitting bodices, floral crowns, corsages, and pearls on fabrics, as well as necklace and bracelets; Neoclassical style still dominated the design of male costumes. Moreover, the role of the ballerina as star dancer became more important and was emphasized with tight-fitting corsets, bejeweled bodices, and opulent headdresses. In 1832, Marie Taglioni's gauze-layered white tutu in *La Sylphide* set a new trend in ballet costumes, in which silhouettes became tighter, revealing the legs and the permanently toe-shoed feet. From this point on, the silhouette of ballet costumes became more tight fitting. The choreography required that ballerinas to wear pointe shoes all the time. The Russian ballet continued to develop in the nineteenth century and such writers and composers as Tolstoy, Dostoevsky, and Tchaikovsky changed the meaning of ballet through the composition of narrative productions. Choreographers of classical ballet, such as Marius Petipa, created fairy-tale ballets, including *The Sleeping Beauty* (1890), *Swan Lake* (1895), and *Raymonde* (1898), making fantasy costumes very popular.

### Twentieth Century

At the turn of the twentieth century, ballet costumes reformed again under the more liberal influence of the Russian choreographer Michel Fokine. Ballerina skirts changed gradually to become knee-length tutus designed to show off the point work and multiple turns, which

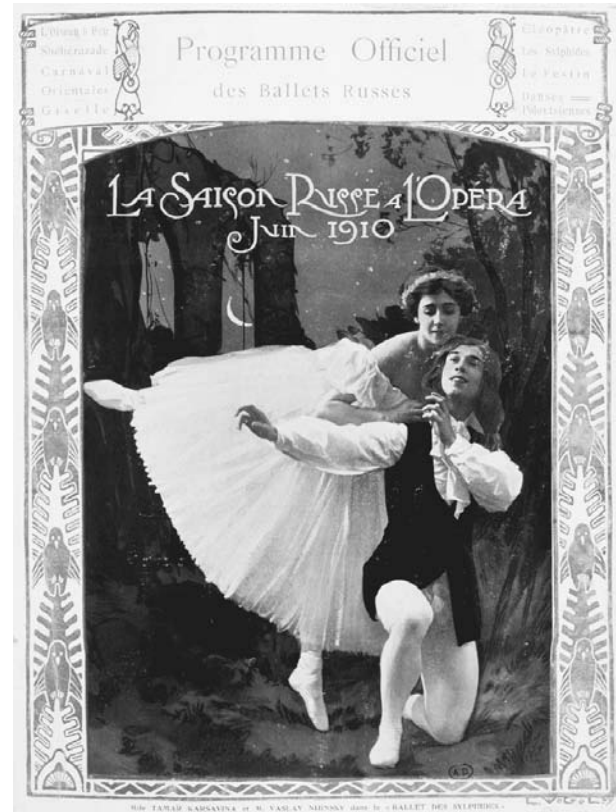

**Program featuring Vaslav Nijinsky and Tamara Karsavina.** By the end of the nineteenth century, tights were a standard part of the male dancer's ensemble due to the great range of motion they offered. © GIANNI DAGLI ORTI/CORBIS. REPRODUCED BY PERMISSION.

formed the focus of dance practice. The dancer Isadora Duncan freed ballerinas from corsets and introduced a revolutionary natural silhouette. The Russian impresario and producer Serge Diaghilev marked this era with his creative innovations, and professional costumers like Alexandre Benois and Léon Bakst demonstrated, in performances such as *Schéhérézade* (1910), that the influence of Orientalism had spread from fashion to the stage and vice versa. Indeed, fashion designers like Jean Poiret had already used the tunic shape taken up by dancers in the prewar era, and, in the 1920s, costume designers updated classical Russian story ballets with exotic tunics and veils wrapped around the body. Ballet dancers were dressed in loose tunics, harem pants, and turbans, rather than in the established tutu and feather headdress. Instead of discreet pastel colors vibrant shades, such as yellow, orange, or red, often in wild patterns, gave an unprecedented visual impression of exciting exoticism to the spectator.

### Modernism and Postmodernism

Modernism liberalized the rules of ballet costumes, and, after Diaghilev's death in 1929, costume design was no longer impeded by restrictions imposed by traditional-



### THE MASK IN BALLET SPECTACLES

Mary Clarke's and Clement Crisp's *Design for Ballet* (London 1978, p. 34) serves to illustrate a vivid description of the importance of masks in ballet performances to stylize characters: "For demons, this was properly hideous; for nymphs it would be sweetly naïve, rivers wore venerable bearded masks, while dwarfs and juveniles might be encumbered with massive heads. Masks were also sometimes placed upon knees, elbows, and the chest to indicate something more of the character." Half-masks were still worn until the 1770s and were from then on replaced by facial makeup.

ists. Nowadays ballet dancers perform in various costumes, which can still include traditional Diaghilev designs. In postmodern productions like Matthew Bourne's *Swan Lake*, the costume designer Lez Brotherston turned the traditional gracile female cygnets into topless, feather-legged male swans. However, fashion designers of the 1990s have picked up the theme of ballerina shoes. The house of Chanel designed elegant, heelless slippers tied up with ribbons and brought the ballerina shoe from the stage to the street.

See also **Dance and Fashion; Dance Costume; Theatrical Costume.**

#### BIBLIOGRAPHY

- André, Paul. *The Great History of Russian Ballet*. Bournemouth, U.K.: Parkstone Publishers, 1998.
- Chazin-Bennahum, Judith. *A Longing for Perfection: Neoclassic Fashion and Ballet*. Oxford: *Fashion Theory* 6, no. 4 (2002): 369–386.
- Clarke, Mary, and Clement Crisp. *Design for Ballet*. London: Cassell and Collier, Macmillan Publishers, Ltd., 1978.
- Kirstein, Lincoln. *Four Centuries of Ballet*. New York: Dover Publications, Inc., 1984.
- Morrison, Kirsty. *From Russia with Love*. Canberra: National Gallery of Australia, 1998.
- Reade, Brian. *Ballet Designs and Illustrations 1581–1940*. London: Her Majesty's Stationery Office, 1967.
- Schouvaloff, Alexander. *The Art of Ballet Russes*. New Haven, Conn., and London: Yale University Press, 1997.
- Williams, Peter. *Masterpieces of Ballet Design*. Oxford: Phaidon Press, Ltd, 1981.
- Wulf, Helena. *Ballet Across Borders*. Oxford and New York: Berg Publishers, 1998.

Thomas Hecht

**BALMAIN, PIERRE** Pierre Balmain (1914–1982) was born in the Savoie region of France in 1914. He studied architecture for a year in Paris before taking a position as a sketch artist with the fashion house of Robert Piguet in 1934. He worked at the House of Molyneux as an assistant designer from 1934 to 1938, and as a designer with Lucien Lelong in Paris in 1939 and from 1941 to 1945. During this time he worked alongside another young designer at Lelong, Christian Dior. In 1945 Balmain founded the Maison Balmain as a couture house with a lucrative sideline in fragrances. He expanded into the American market in 1953, showing his collections under the brand name Jolie Madame. The Balmain perfume business was sold to Revlon in 1960, but Pierre Balmain continued as the proprietor and chief designer of the Maison Balmain until his death in 1982.

The fashion historian Farid Chenoune described Pierre Balmain as one of "the supreme practitioners of the New Look generation," along with Christian Dior and Jacques Fath. During the 1950s and 1960s, Balmain's clients included some of the world's most elegant and best-dressed women, such as Katharine Hepburn, Vivien Leigh, Marlene Dietrich, and Queen Sirikit of Thailand.

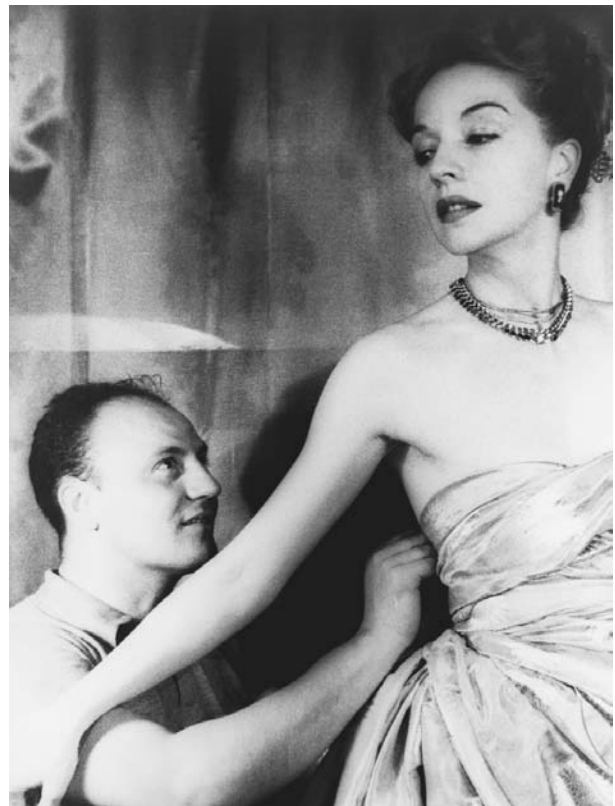

**Pierre Balmain fitting a dress.** A devotee of the basic principals of fashion, Balmain opened Maison Balmain in 1945, and began producing elegant creations that yielded him several famous clients. © CORBIS. REPRODUCED BY PERMISSION.



**Pierre Balmain, 1956.** The woman models an elegant, strapless sheath dress made of embroidered French lace. A greige taffeta sash adds to the sleek line of the look, and the mink stole, lined with the lace, gives a flare of luxury. © BETTMANN/CORBIS. REPRODUCED BY PERMISSION.

Balmain's work was characterized by an emphasis on impeccable construction and simple elegance. He is credited with popularizing the stole as an accessory. He once said, "Keep to the basic principles of fashion and you will always be in harmony with the latest trends without falling prey to them."

The Maison Balmain continued in business after Pierre Balmain's death, with several designers and under shifting ownership throughout the 1980s. A ready-to-wear line was added in 1982. The company reacquired its perfume business from Revlon but unwisely entered into extensive licensing agreements that put the Balmain name on a wide range of products, diluting the company's image. In 1993 Oscar de la Renta took on the position of chief designer for the Maison Balmain—the first American to become head designer for a Paris couture house. De la Renta's first collection for the company, which appeared on the runway in February 1994, was a critical and commercial success. Critics generally agree that de la Renta, who spent nearly a decade at Balmain, succeeded not only in reviving the company's fortunes, but also in restoring the house's old reputation for elegance. Oscar de la Renta presented his final collection for Balmain in July 2002. He was succeeded by Laurent

Mercier, who was artistic director from 2002 to 2003, and Christophe Lebourg, who was appointed in 2003.

*See also* **De la Renta, Oscar; Dior, Christian; Fath, Jacques; New Look; Paris Fashion; Perfume.**

#### BIBLIOGRAPHY

- Benbow-Pfalzgraf, Taryn, ed. *Contemporary Fashion*. 2nd ed. Farmington Hills, Mich.: St. James Press, 2002.
- Buxbaum, Gerda, ed. *Icons of Fashion: The 20th Century*. Munich, London, and New York: Prestel Verlag, 1999.
- Milbank, Caroline Rennolds. *Couture: The Great Designers*. New York: Stewart, Tabori and Chang, 1985.
- Pierre Balmain: 40 années de création*. Paris: Musée de la Mode et du Costume, 1985.

*John S. Major*

**BALZAC, HONORÉ DE** Honoré Balzac was born to an aspiring bourgeois family in Tours, France in 1799. The family later attributed itself an aristocratic particle, making him Honoré de Balzac. The famous writer died in Paris in 1850, having authored over ninety novels and numerous plays, articles, and short stories.

Balzac avoided the word "dandy" in his writings. In France in the 1830s and 1840s it had negative connotations of foppishness and English eccentricity. In his *Traité de la vie élégante* (*Treatise on the Elegant Life*) of 1830, he wrote: "In making himself a dandy, a man becomes a piece of boudoir furniture, an extremely ingenious mannequin, who can sit upon a horse or a sofa ... but a thinking being ... never." Despite his critiques of the dandy's intellect, he greatly admired masculine elegance and British tailoring. One of his most famous literary dandies, Henry de Marsay, epitomizes the sexual appeal and ambiguity of Balzac's version of the dandy. De Marsay was "[...] famous for the passions he inspired, especially remarkable because of his beauty, like that of a young girl, a soft, effeminate beauty, but counterbalanced by his steady, calm, wild and fixed gaze, like that of a tiger: he was loved and he caused fear" (*Lost Illusions*). Balzac's writings emphasized the contrast between the dandy's leisured cultivation of elegance and the dull soulless drudgery of the workingman's life. His philosophy stands at the cusp between a British model of dandyism as a phenomenon embedded in a specific social context and later nineteenth-century French and British ideas of the decadent dandy. He influenced writers such as Charles Baudelaire and Joris-Karl Huysmans, for whom the dandy was a heroic outsider rebelling against increasing industrialization and social uniformity.

Balzac cultivated his personal style and public image. At the end of 1830, he owed his tailor 904 francs, which was more than his entire yearly budget for food and lodging in Paris. As a young, upwardly mobile writer he described his extraordinary dress as a *réclame* or advertisement and claimed that his cane caused all of Paris





**Honoré de Balzac.** Known for his own somewhat flamboyant fashion style, Balzac paid particular attention to dress and clothing in his writings, even using famous tailors as characters in his books. PUBLIC DOMAIN.

to chatter. Indeed, Balzac's accessories seem to have been particularly remarkable: he carried a monstrous cane studded with turquoise, wore coat buttons of elaborately carved gold, and modeled an astonishing variety of waistcoats and gloves. Despite his efforts at elegance, he did not always cut a fine figure and his flamboyant style was not always favorably received. Physically, he was short and squat, and he sacrificed attempts at personal hygiene when deeply involved in his work. Captain Gronow remarked that he wore sparkling jewels on dirty shirtfronts and diamond rings on unwashed fingers.

He patronized several famous tailors and these men, along with haberdashers, glovemakers, and other tradesmen, feature prominently in his novels. It is rumored that he had his clothing paid for by advertising certain tailors—including their names, addresses, and eulogies of their products—in his writing. For example, in the novel *Lost Illusions* (*Illusions Perdues*, 1837–1843) the young provincial poet Lucien de Rubempré is shamed when he pays cash for an ill-fitting, bright green ready-made suit and wears it to the Paris Opéra. The mature dandy Henry de Marsay insults Lucien, comparing him with a clothed tailor's mannequin. The next day he goes

to Staub, who was one of Balzac's own tailors, and spends most of his yearly income on a new outfit. When he returns to his native Angoulême, he turns his new appearance to his advantage. In his skin-tight black trousers he attracts all of the noblewomen of the city. They flock to see him in his new role as a handsome *lion* or man of fashion. Balzac observes that the styles of the day were best suited to sculptural physiques: "Men still showed off their bodies, to the great despair of the thin or badly-built, and Lucien's form was Apollonian." The Staub suit transforms Lucien's existence in Paris, catapults him to instant notoriety and helps him launch his literary career. This novel celebrates the social power of dress and demeanor.

Honoré de Balzac's early journalistic writing pays particular attention to men's fashion. The most important publication related directly to dandyism is the *Traité de la vie élégante* (*Treatise on the Elegant Life*), which was published in Émile de Girardin's royalist review *La Mode* between 2 October and 6 November 1830. This text fictionalizes the British dandy George Brummell, whom he calls the "patriarch of fashion." Balzac uses him as a mouthpiece to expound his own principles on elegant dress and lifestyle. In the *Treatise*, he pioneered the concept of *vestignomonie* (vestignomony), a pun on the pseudoscience of physiognomy. While physiognomists claimed to be able to read human character from facial types and expressions, Balzac affirmed that clothing could be read and deciphered in the same way. Despite the seemingly increasing uniformity of dress in democratic, post-revolutionary France, Balzac claimed that it was easy for the observer to distinguish between men from various social strata and professions. He claimed that clothes revealed the Parisian doctor, aristocrat, or student from the neighborhoods of the Marais, the Faubourg Saint-Germain, the Latin Quarter or the Chaussée d'Antin.

While much of Balzac's early work was published in fashionable journals like *La Mode*, *Le Voleur* and *La Silhouette*, his later writings demonstrate a sustained interest in vestimentary style. Dress and clothing play a central role in the ninety-odd volumes of *La Comédie Humaine* (*The Human Comedy*) named as a pun on Dante's *Divine Comedy*. These novels constitute a panorama of French social life from the Revolution (1789) to the end of the July Monarchy (1848). The most important dandy figures in his novels include Eugène de Rastignac, Lucien de Rubempré, Maxime de Trailles, Charles Grandet, Georges Marest, Amédée Soulas, Lousteau, Raphael Valentin and Henry de Marsay. Some of his most important novels were *Old Goriot*, *Eugénie Grandet*, *Lost Illusions*, and *Cousin Bette*.

Balzac's detailed observations and extensive descriptions paint a vivid picture of the nuances of dress in his period and herald the importance given to fashion in realist literature. While Balzac's importance to the study of fashion is taken for granted in French literary criticism,

many of his important journalistic texts have not yet been translated into English. Nonetheless, his novels contain some of the most engaging and sophisticated verbal descriptions of fashion in the history of literature.

See also **Fashion, Historical Studies of.**

#### BIBLIOGRAPHY

- Balzac, Honoré de. *Lost Illusions (Illusions perdues)*. Translated by Herbert J. Hunt. Harmondsworth, U.K.: Penguin, 1971.
- . *Traité de la vie élégante, suivi de théorie de la démarche*. Paris: Arléa, 1998.
- Boucher, François, and Philippe Bruneau. *Le vêtement chez Balzac*. Paris: extraits de la Comédie humaine l'Institut Français de la Mode, 2001.
- Fortassier, Rose. *Les écrivains français et la mode*. Paris: Puf, 1988.
- Moers, Ellen. *The Dandy: Brummell to Beerbohm*. London: Secker and Warburg, 1960.

*Alison Matthews David*

**BARBERS** The word “barber” is derived from the Latin *barba* meaning “beard,” and the profession of barber has been in existence since the earliest recorded period. In Ezekiel 5:1, for instance, “the son of man” is urged to “take thee a barber’s razor and cause it to pass upon thy head and upon thy beard.” The professional status of the barber has changed dramatically over the centuries. The medieval barber was a “barber-surgeon” responsible for not only shaving and trimming hair, but also for dental treatment and minor surgery, especially *phlebotomy* or bleeding. Barber-surgeons were organized into guilds as early as the twelfth century in Europe, and one of the most famous, the Worshipful Company of Barbers, was created in London in 1308. Barber-surgeons could be recognized in the seventeenth century by their uniform, a “checque parti-coloured apron; neither can he be termed a barber, or poler, or shaver till the apron is about him” (Randle Holme, 1688; in Stevens-Cox, p. 220). The apron had a large front pocket that held the tools of the trade. A white or gray coat had supplanted this traditional outfit by the early twentieth century.

The barber’s premises were marked out by a standard sign—a blue, red, and white striped pole. This symbol was derived from the pole gripped during bleeding when the vein in the bend of the elbow was opened. As this operation was performed without anesthetic, it was often painful. When not in use, the pole stood outside the barbershop as sign of service, and the image was incorporated into the characteristic sign that developed. The red and blue on the sign represented the blood of the veins and arteries, and the white symbolized the bandages used after bleeding. The seventeenth-century fashion for a smooth-shaven face led to a boom in trade. The barber would soften the client’s bristles with a mixture of soap and water, oil, or fat using a hog bristle brush and then shave him using a well-stropped razor. Demand for bar-

bers’ services continued with the increasing complexity of men’s hairstyles in the late eighteenth century and the popularity of beards in the nineteenth century.

Barbers had declined in prestige by this time, however, as a result of the trades of barber and surgeon being made independent of one another in 1745. Surgery became a well-respected profession, and barbering began to be viewed as a lowly occupation (as had been true all along in many other cultures). The barbershop of the nineteenth century gained a reputation as a rather insalubrious place, a gathering place of idle and sometimes rowdy men. In Europe, barbers had a reputation as procurers of prostitutes and cigars, and by the mid-twentieth century, contraceptives, leading to the popular English phrase, “A little something for the weekend, Sir?”

The practice of barbering was also regarded as unsanitary. In the nineteenth century, a client could be the recipient of a “foul shave” from infected razors and hot towels passed from customer to customer without being cleaned, which caused infections commonly referred to as “barbers’ itch.” A contemporary description of a barber ran: “The Average Barber is in a state of perspiration and is greasy; his fingers pudgy and his nails in mourning; he snips and snips away, pinching your ears, nipping your eyelashes and your jaw... he draws his fingers in a pot of axle grease, scented with musk and age, and before you can define his fearful intent, smears it all over your head” (*Hairdressers’ Weekly Journal*, p. 73). The British trade publication *Hairdressers’ Weekly Journal* chose this description of 1882 to begin a concerted campaign calling for better education and standards of hygiene among barbers, designed to improve their image and status.

In America, a tradition had developed in the late eighteenth century of black-owned barbershops that catered to a white clientele; prosperous black barbers often became leading members of their communities. After the Civil War, however, the laws of racial segregation in many states prohibited black barbers from tending to white customers, and barbering declined in importance as an African American trade. By 1899–1900 Italian men made up sixty percent of immigrant barbers. In Italy, Spain, and France, haircutting was regarded as a profession of skill and dexterity. The contrast in public image was striking: Spain’s Barber of Seville versus England’s Sweeney Todd, the demon-barber of Fleet Street.

The practice of self-shaving also transformed the role of the barbershop. Jean Jacques Perret invented the first safety razor with a wooden guard along the blade in 1770, but the self-shaving revolution really began with the invention of the Gillette safety razor in 1895. Throughout the twentieth century, barbershops increasingly relied on haircutting rather than shaving as the basis of their trade.

By the 1920s some brave women were prepared to enter the masculine arena of the barbershop to get their





**Nineteenth-century British illustration.** Barbershops of the nineteenth century often had rather unsavory reputations, due partly to the clientele, which was regarded as uncouth, and partly to the perceived unsanitary practices of the barbers themselves. © HISTORICAL PICTURE ARCHIVE/CORBIS. REPRODUCED BY PERMISSION.

hair bobbed. One of these women remembers “walking through the barbershop and being very conscious that we were somehow transgressing male space. The barbershop was filled with groups of men chewing tobacco and engaged in conversations about weather, politics, rodeo, and wrestling” (Willett, p. 1). The vogue for short haircuts was so prevalent that the few hairdressers who could actually cut rather than dress hair were fully booked, and in any case many women preferred to give their hair up to the skill of the barber rather than the hairdresser. Women’s hairdressers quickly fought back with formal education and the introduction of lush salons where female clients could be pampered.

With the more elaborate hairstyles of the 1950s, in particular the variations of the pompadour, men began to spend more time and money at the barbers’, who began to use the term “men’s stylists” to distinguish themselves from the old-fashioned barbershops. By the late 1960s, the longer hair trends for men, which had developed out of counterculture styles, meant fewer and fewer visits to the barber. In the United States, the census figures reported that between 1972 and 1982 the number

of barbershops fell by more than 28 percent. This necessitated a change in tonsorial skills and marketing and by 1970 journalist Rodney Bennett-England, who specialized in male grooming, declared, “The old barber, trained in the use of electric clippers, was a technician. Today’s barbers are stylists, even artists” (p. 104). He described salons for men that “resemble gentlemen’s clubs with deep, comfortable armchairs, wood panelled walls and pictures or prints....you can easily while away a complete half-day having your hair heightened, lightened and brightened, your hands manicured and your tired face cleansed and patted back into new vigour” (p. 105). The old barbershop still existed by the early 2000s with a dwindling clientele, but many men with an interest in fashionable haircuts go to “unisex” hairdressers who no longer bother to specialize in either male or female clients.

See also **Hair Accessories; Hairdressers; Hairstyles.**

#### BIBLIOGRAPHY

Bennett-England, Rodney. *As Young as You Look: Male Grooming and Rejuvenation*. London: Peter Owen, 1970.



Byrd, Ayana D., and Lori L. Tharps. *Hair Story: Untangling the Roots of Black Hair in America*. New York: St. Martin's Press, 2001.

Cox, Caroline. *Good Hair Days: A History of British Hairstyling*. London: Quartet Books, 1999.

*Hairdressers' Weekly Journal* 3 (June 1882): 73.

Stevens-Cox, James. *An Illustrated Dictionary of Hairdressing and Wigmaking*. London: B. T. Batsford Ltd., 1989.

Willett, Julie A. *Permanent Waves: The Making of the American Beauty Shop*. New York: New York University Press, 2000.

Caroline Cox

**BARBIE** Since the Mattel corporation introduced Barbie in 1959, the doll's relation to fashion, sex, femininity, and cultural values has been a subject of spin control, change, and controversy.

Early official accounts of Barbie's beginnings emphasized the desire of Ruth Handler, Mattel's co-founder, to produce a three-dimensional version of the paper fashion dolls her daughter, Barbara, loved. But Barbie's body actually originated elsewhere: with a German character named Lilli, who appeared in cartoon and doll form primarily as a sexpot plaything for adult men. Mattel bought all the rights and patents required to remove Lilli from that context of meaning and turned her into Barbie, the "shapely teenage Fashion Model!" announced in early catalogs.

Changes followed soon after the doll's launch, as Mattel worked to gear Barbie's persona to sales and supplementary products. In a 1961 television ad, Barbie, although still described as a fashion model, had acquired a school life, a boyfriend, and outfits for activities ranging from school lunches to frat parties: "Think of the fun you'll have taking Barbie and Ken on dates, dressing each one just right." The ad's invitation to "see where the romance will lead" illustrated Barbie's dreamy future by showing her in a wedding dress, a costume that would recur in many subsequent versions. Other outfits to come included the latest in formal wear, casual attire, sports gear, and lingerie. Many fashions were modeled after the work of contemporary designers. Sometimes Mattel enlisted designers directly, especially for the high-end offerings later created to cash in on the ever-increasing traffic in Barbie collectibles. Like designer Bob Mackie's 1991 "Limited Edition Platinum Barbie," these sometimes sold for up to several hundred dollars each.

### Careers and Colors

Over the years, too, Barbie saw expanding options in one type of costume that would generate praise, humor, doubt, and derision: the career outfit. In the early 1960s, Barbie's career identities were primarily traditionally female, like nurse; largely unattainable, like astronaut; or both, like ballerina. Barbie had less work, ironically, during the burgeoning of popular feminism in the 1970s.



**Lettie Lane paper doll with clothes.** Mattel co-founder Ruth Handler's desire to produce a three-dimensional version of paper dolls such as these was the genesis for Barbie. © CYNTHIA HART DESIGNER/CORBIS. REPRODUCED BY PERMISSION.

Her career life took off in the mid-1980s, however, with the Day-to-Night Barbie line. Its first incarnation presented Barbie as an executive, whose pink suit could be transformed into evening wear. She came with the slogan "We Girls Can Do Anything," a catchphrase relevant also to the range of careers that Barbie adopted into the 1990s, which included doctor, veterinarian, UNICEF ambassador, rock star, rap musician, teacher, chef, Marine Corps sergeant, and professional basketball player for the WNBA.

Besides addressing concerns about whether a girl with few apparent interests other than fashion, fun, and spending a vast amount of cash on clothes, cars (like the Barbie Ferrari), and real estate (like the famed Barbie Dream House) provided a good role model, career Barbies suited an important change in Mattel's marketing strategy. Initially, Mattel wanted consumers to supplement their first Barbie with outfits, accessories, and other characters such as Ken and Midge, Barbie's close yet dis-



**Barbies on display.** Since her introduction in 1959, Barbie has been marketed with many different looks to entice children to buy multiple dolls. This strategy appears to have paid off, as the average number of Barbies owned per child grew to ten in the 1990s. © BETTMANN/CORBIS. REPRODUCED BY PERMISSION.

tinctly unglamorous friend. In fact, the promotion for the 1967 Twist 'N Turn Barbie even offered a trade-in deal. Later, promotions became geared to the purchase of multiple Barbies. In 1992, for example, a Barbie owner interested in the rapper outfit had to buy Rappin' Rockin' Barbie, or four of them to get each of the different boom boxes. Another trend sponsored by Mattel that catered simultaneously to sales and social consciousness was the increase in Barbies of color and Barbies representing countries outside the United States. Changing statistics about how many Barbies the "average child" owns suggest Mattel's success at shifting multiple acquisitions to Barbie herself, with the number climbing from seven to ten over the course of the 1990s.

### Controversies

With Barbie's popularity has come increasing controversy, both about Barbie's (unrecyclable) plastic body and about the flesh to which it does, or does not, refer. To a number of critics, Barbie represents shallow feminism, focused primarily on individual success and fulfillment, and Barbie's world looks like diversity lite, peopled by innumerable white, blond Barbies, unquestionably front

and center, and a much smaller number of Barbies who look like white Barbies with skin and hair dye jobs. Detractors have advanced other arguments as well: that Mattel's restriction of Barbie's dating life to boys adds yet another set of cultural narratives guiding young people to see heterosexuality as the desired, perhaps required, norm; that Barbie's impossible-to-attain proportions contribute to cultural ideals of beauty that invite self-loathing and unhealthy eating practices; and that Barbie promotes an undue focus on looks in general. Why give a girl Soccer Barbie (1999) instead of a soccer ball?

Yet as other commentators have noted, Barbie has generated a lot of play far from Mattel's official sponsorship. Mattel's WNBA Barbie may not emerge from the box with the characteristic butch flair displayed by many of her charming human counterparts, but in the hands and minds of many consumers, Barbie has been butched out, turned out, fixed up with diverse sex mates, and, of course, undressed; for a doll whose wardrobe forms the centerpiece of her reputation, she spends quite a lot of time naked. Then again, for some critics, this is Mattel's fault, too. People who like to imagine children as innocent of sexual desires have accused the company

of turning their children's minds to sex with its big-breasted adult doll. Others, conversely, have mourned what Mattel couldn't do: inspire femininity in their daughters or distaste in insufficiently truck-minded sons.

### Object of Attention

From all these diverse uses and assessments of Barbie, one certainty emerges. Barbie remains an object of attention, fascination, and, of course, purchase. Whatever her influence has been—and surely it has varied among individuals and over time—she has successfully convinced many of her importance as a symbol of femininity, as a catalyst for fantasy, and as a marker and agent of cultural values.

See also **Fashion and Identity**; **Fashion Dolls**.

### BIBLIOGRAPHY

BillyBoy. *Barbie: Her Life and Times*. New York: Crown Publishers, 1987. Excellent source of fashion study and illustrations.

DuCille, Ann. *Skin Trade*. Cambridge, Mass.: Harvard University Press, 1996. Critical issues including race.

Lord, M. G. *Forever Barbie: The Unauthorized Biography of a Real Doll*. New York: Morrow and Company, 1994. History.

Rand, Erica. *Barbie's Queer Accessories*. Durham, N.C., and London: Duke University Press, 1995. History, consumers, subversions.

*Erica Rand*

**BARBIER, GEORGES** The French illustrator, painter, and theatrical designer Georges Barbier (1882–1932) was born in the seaport city of Nantes. The city's seventeenth- and eighteenth-century architecture, as well as its art museum collections, with works by Antoine Watteau and Jean-Auguste-Dominique Ingres, influenced Barbier's aesthetic sensibilities. As a young man he moved to Paris where, between 1908 and 1910, he studied at l'École des beaux-arts in the atelier of the academic history painter, Jean-Paul Laurens. Although Barbier's artistic style differed significantly from that of his teacher, his appreciation of the past as a source of inspiration was undoubtedly reinforced by Laurens's subjects.

In the galleries of the Louvre, Barbier discovered the art of classical antiquity. His enduring admiration for Greek and Etruscan vases, Tanagra figurines, and small Egyptian sculptures is evident in his depiction of the human body and resonates overall in the clarity and restraint of his graphic work. His refined color sense and use of strong colors, influenced by costumes of the Ballets Russes, which was founded in Paris in 1909, also characterize his work.

Barbier first exhibited at the Salon des humoristes in 1911, where his drawings were immediately acclaimed; subsequently, he was a regular contributor to the Salon des artistes décorateurs. Barbier was a prolific and skill-



**Rendez-vous by Georges Barbier.** Barbier's illustrations employed strong colors and casual elegance to depict the 1920s fashionable ideal. Barbier's figures, with strong forms and dark-lidded eyes, slightly exotic eyes, represented the concept of female beauty and grace. © STAPLETON COLLECTION/CORBIS. REPRODUCED BY PERMISSION.

ful artist whose sophisticated style was in great demand. Over the course of his brief career, he contributed to most of the leading French fashion journals and almanacs; illustrated numerous publications of classic and contemporary French prose and poetry issued in limited, deluxe editions; and designed costumes for stage productions, including ballet, film, and revues, such as the Folies Bergère and the Casino de Paris. In addition, Barbier wrote essays on fashion that appeared in *La Gazette du bon ton* and other journals, and as a member of the Société des artistes décorateurs, he produced designs for jewelry, glass, and wallpaper. One of the most well-known and highly regarded artists working in the second and third decades of the twentieth century, Barbier died in Paris at the peak of his profession in 1932.

### Barbier and Art Deco

In Michael Arlen's best-selling 1924 novel, *The Green Hat*, the heroine Iris March is compared to a figure in a Barbier fashion illustration: "She stood carelessly like the women in Georges Barbier's almanacs, *Falbalas et Fanfreluches*, who know how to stand carelessly. Her hands were thrust into the pockets of a light brown leather jacket—pour le sport" (Steele, p. 247). The casual elegance ascribed to Arlen's character, a quintessential element of the 1920s fashion ideal, epitomizes Barbier's



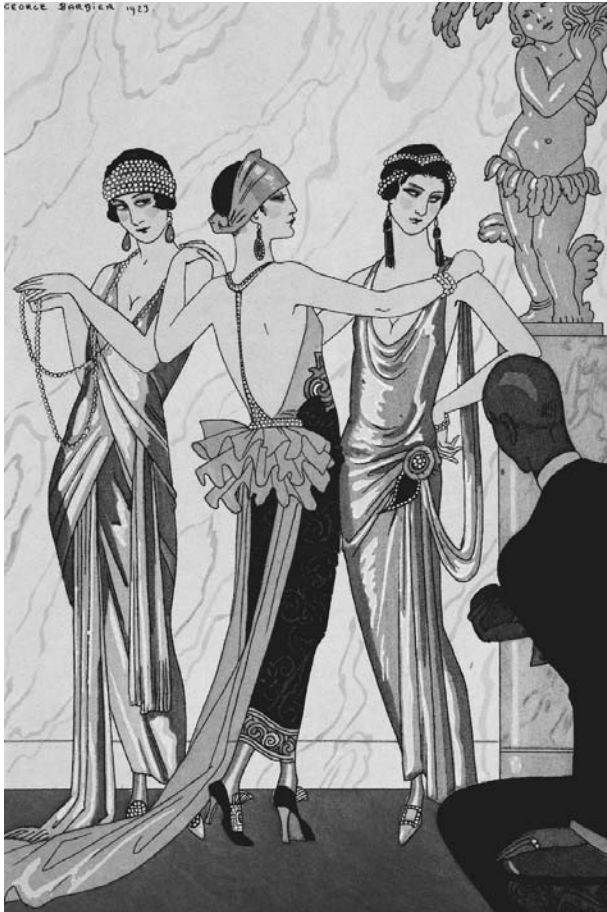

**The Judgement of Paris, ca. 1915.** Painted by French artist Georges Barbier, three women display haute couture of the art deco period. Influences of classic antiquity show in the design of the head adornments, the jewelry, and the dresses. High-heeled shoes square off the modern look. © STAPLETON COLLECTION/CORBIS. REPRODUCED BY PERMISSION.

figures. With their strong yet lithe forms and dark-lidded, slightly exotic eyes, Barbier's women embody the notions of female beauty and grace of the time.

Beginning with the innovative and influential *Le Journal des dames et des modes* (1912–1914), launched by Lucien Vogel, Barbier's talents were sought after by the publishers and editors of avant-garde fashion magazines. Following the lead of the couturier Paul Poiret, whose collaboration with the artists Paul Iribe and Georges Lepape in 1908 and 1911, respectively, set the standard for a new, modernist presentation of fashion, these publications showcased the emerging art deco aesthetic. Rather than realistic, fussily detailed renderings of dress, Barbier and his fellow illustrators (Lepape, Iribe, Bernard Boutet de Monvel, Pierre Brissaud, and Charles Martin, among others) created bold, stylized images that conveyed mood and atmosphere. The laborious technique of *pochoir* printing used for these illustrations (a hand-stenciled

process whereby layers of color are built up in gouache paint) enhanced their visual impact.

In addition to *Le Journal des dames*, Barbier contributed widely to other luxury fashion periodicals including *La Gazette du bon ton* (1912–1925), *Les Feuilles d'art* (1919–1922), and *Art goût beauté* (1920–1933), as well as *Vogue*, *Femina*, and *La Vie parisienne*. Barbier was also commissioned to illustrate more specialized fashion publications: couturiers' albums and almanacs, such as *Modes et manières d'aujourd'hui* (1912–1923), *La Guirlande des mois* (1917–1920), *Le Bonheur du jour* (1920–1924), and *Falbalas et fanfreluches* (1922–1926). Modeled after the early nineteenth-century publication *Le Bon genre* that chronicles the modes and lifestyle of the First Empire and the Bourbon restoration, Barbier's refined and often witty drawings for particular almanacs not only depict Parisian haute couture but also record the social scene and fashionable activities in charming vignettes.

### Set Designs and Costumes

Although it is primarily through Barbier's fashion illustrations that one is familiar with his work, in his lifetime his book illustrations and theatrical costume designs contributed significantly to his artistic reputation and success. Both authors with whom he collaborated and critics agreed that Barbier was able to distill the essence of a literary text and give it visual form. His interpretations of historic dress and interiors for the stage (including *Casanova* and *La Dernière nuit de Don Juan* by Edmond Rostand, *Marion Delorme* by Victor Hugo, and *Lysistrata* by Maurice Donnay) were admired for their imaginative evocation of a particular time and place, rather than representing merely a scrupulous imitation or pastiche. Barbier's love of the exotic resulted in spectacular beribboned, furred, feathered, and jeweled fantasy costumes for revue performers at popular Paris nightclubs.

### Legacy

In the preface to *Personnages de comédie* (1922), illustrated by Barbier, Albert Flament refers to him as "One of the most precious and significant artists of our era. . . . When our times are lost . . . in the dust . . . some of his watercolours and drawings will be all that is necessary to resurrect the taste and the spirit of the years in which we have lived" (Ginsburg, p. 3). Barbier was undoubtedly one of the preeminent fashion illustrators of the early twentieth century. Among the group of artists including Lepape, Iribe, and Monvel, dubbed "The Knights of the Bracelet" by *Vogue* in 1922 (a reference to their "dandyism . . . and love of luxury" [Barbier, p. 6]), Barbier was in the forefront of the alliance between art and fashion. His superb draftsmanship, color sense, and ability to infuse freshness into historic influences combine to produce distinctive images that define the modernity of the art deco style.

See also **Art Nouveau and Art Deco; Fashion Illustrators; Fashion Magazines.**

## BIBLIOGRAPHY

- Barbier, Georges. *Art Deco Costumes*. New York: Crescent Books, 1988.
- Mackrell, Alice. *An Illustrated History of Fashion: 500 Years of Fashion Illustration*. New York: Costume and Fashion Press, 1997.
- Steele, Valerie. *Paris Fashion: A Cultural History*. New York: Oxford University Press, 1988.
- Vaudoyer, Jean-Louis, and Henri de Régner. *George Barbier: Étude Critique*. Paris: Henry Babou, 1929.
- Weill, Alain. *Parisian Fashion: La Gazette du bon ton, 1912–1925*. Paris: Bibliothèque de l'Image, 2000.

Michele Majer

**BARK CLOTH** The term “bark cloth” has been known by various names in the Pacific Islands, including: tapa or *kapa* (Hawaii), *ngatu* (Tonga), *abu* or *ka’u* (Tahiti), *masi* (Fiji), and *autea* (Cook Islands). “Tapa” is the popular word now used to describe bark cloth throughout the Pacific Islands. Bark cloth, or tapa, describes the fabric whose source material is the bark of a tree or similar plant material grown in tropical areas around the world and is, therefore, cellulosic. Like felting, bark cloth produces a nonwoven fabric. Like felting, bark cloth or tapa is produced in a warm, moist environment. While the bonding of fibers in felt is mechanical, the bonding in bark cloth is chemical.

One of the plants carried by exploring Polynesians was paper mulberry (*Broussonetia papyrifera*), called *wauke* by Hawaiians. In addition to paper mulberry, several other plants found in tropical locales have been used for making bark cloth.

### Production

To start the bark-cloth-making process, the inner bark (bast) of a tree or plant was stripped or removed from its source, the outer bark of a tree or branch, and cleaned. The bast fibers were then placed in water, often seawater, causing the fibers to break down (ferment or ret) into a somewhat sticky substance resembling bread dough. The substance was spread on a specially carved flat wood surface called a *kua kuku* in Hawaiian and then beaten with grooved wooden beaters, called *boboa*, of various thicknesses. As the substance was beaten, it became wider, longer, and thinner and began to dry. It was spread into a thin sheet and laid out to dry with stones holding the edges in place against the winds. The result, depending on thickness, was a fairly supple, somewhat paperlike sheet of fabric. The beating of a *boboa* on a *kua kuku* was also reportedly sometimes used for sending messages. The special houses or sheds used for beating tapa were called *hale kuku*, and when people gathered for beating, it could be compared to a modern quilting group or party.

Bark-cloth-making was refined in many areas of Polynesia, especially Hawaii. Though pieces of tapa were most commonly beaten or pounded together to make larger pieces, tapa pieces were also sewn together with fiber and a wooden needle. Edges were turned under and fused, by beating or sewing, for evenness. Various thicknesses for different purposes could be achieved in the beating process. Fabric could be made so thin as to be gossamer, or thicker strips of the fabric were sometimes plaited.

### Decorative Bark Cloth

Many sources agree that Hawaiians developed the most complex and greatest number of decorative prints for bark cloth. Some tapa was dyed first by soaking, or sometimes by brushing the dye onto the fabric, or even beating an already dyed piece of tapa into a larger piece. The Hawaiians carved designs into pieces of bamboo often shaped like thin paddles. These strips of carved wood were then used to stamp or print on the tapa with dyes from plants and soil and other sources. The Hawaiians were careful and precise printers, making sure that patterns were straight and continuous. Several patterns might be used on one length of tapa, creating unique patterns. Interesting patterns could also be obtained by plaiting or twisting pieces of tapa or other plant materials into a long strip and then pressing the length against the tapa. The most common colors used were brown, black, pink, red, green, pale to medium blue, and yellow.

### Uses

Bark cloth was derived and used as fabric in other tropical areas well into the late twentieth century. South American Indian populations still living in the remote forests of Brazil, Panama, and Colombia used bark cloth, called *damajagua* (Colombia), as sleeping mats. Based on photographs and descriptions of researchers, the bark cloth of the South American Indians is crude compared with the bark cloth produced in the Pacific Islands. It appears that one of the biggest reasons South American bark cloth was coarser than that of Polynesia is that the retting time allowed for the bast fibers was considerably shorter, overnight, compared with the several days of retting by Polynesians.

Throughout the Pacific Islands, bark cloth was used as a household fabric for both bedding and clothing, and in making ceremonial objects. As clothing, the fabric was wrapped and tied onto the body. It could be gathered or pleated in various ways to create decorative effects for ceremonial occasions.

In everyday use, women commonly wrapped the bark-cloth fabric, called a *pa’u*, around their bodies and tied and tucked the ends in to keep it in place. Women commonly covered only the lower part of their bodies between the waist and knees with the *pa’u*.



**Women fold bark cloth.** Produced throughout the Pacific Islands, bark cloth is made from the bark of a tree or similar plant. The cloth was used for bedding and clothing, and in making ceremonial objects, but was rarely used by the early 2000s. © JACK FIELDS/CORBIS. REPRODUCED BY PERMISSION.

The *malo*, worn by men, was also wrapped around the body and between the legs to protect the genitalia. The *malo* might or might not have a flap in the front, which could be tucked away depending on tasks that needed to be performed on a given day. Originally only men performed the hula. When performing, additional pieces of tapa could be tied over the *malo*. Tapa was also tied around the shoulders by both men and women when a little extra warmth was needed. Such capes were called *kibe*.

The largest and most elaborate pieces of Hawaiian tapa were made into bedding. Five to eight sheets of plain white tapa were sewn along one edge and then topped with a dyed and watermarked piece. During cool nights the layers could be draped over the sleeper, or laid back, for desired warmth. Tapa was also scented on occasion. Sap, leaves, or flowers were mixed with oil and heated and then added to a dye.

Bark cloth is rarely used for clothing today. It lacks the pliability of woven fabrics, it tends to break down when wet, and processing is labor intensive. The fabric does, however, give important information about the tropical cultures in which it was developed. Hobbyists,

historians, and others continue to make bark cloth to study and to keep the knowledge and skill of tapa-making alive. In the Pacific Islands, tapa was not found in common usage after the turn of the nineteenth century.

See also **Felt**; **Nonwoven Textiles**.

#### BIBLIOGRAPHY

Abbott, I. A. *La'au, Hawaii: Traditional Hawaiian Uses of Plants*. Honolulu, Hawaii: Bishop Museum Press, 1992. Abbott is a world-renowned psychologist and Hawaiian ethnobotanist of Hawaiian and Chinese extraction.

Hiroa, Te Rangi [Sir Peter H. Buck]. *Arts and Crafts of Hawaii: Clothing*. Honolulu: Bishop Museum Press, 1957. Buck was director of the Bishop Museum from 1936 to 1951. He was the son of a Maori chiefess and an Irish father. He served as physician and anthropologist and is noted for his substantial contributions to Pacific ethnology.

Kaepler, A. L. *Artificial Curiosities*. Honolulu: Bishop Museum Press, 1978.

Kooijman, S. *Tapa in Polynesia*. Honolulu: Bishop Museum Press, 1972.

*Carol A. Dickson and Isabella A. Abbott*



**BARTHES, ROLAND** Better than anyone else, the author of *Roland Barthes par Roland Barthes* (1974) as well as of *Le Degré zéro de l'écriture* (1953) pointed out the illusory nature of the work of biography. Here, we will therefore merely recall a few fragments of a life whose intellectual twists and turns accompanied and helped to transform all facets of French, if not European, thought in the second half of the twentieth century. His publications easily demonstrate his role as developer—in the photographic sense of the term—of the founding questions of so-called postmodern thought. They reveal even more the qualities of a refined and elliptical writer haunted by *The Pleasure of the Text* (1973). Well known for works, alternately journalistic and scholarly, on the political use of myths, literary creation, mass culture, photography, semiological methods, and romantic desire, Barthes also wrote many diverse works on fashion. Often referred to but very little read for themselves, these works still call for a radically novel approach to the phenomena of fashion.

### Fragments of Life

Following Jean-Baptiste Farges and Andy Stafford, one can try to distinguish three moments—but they are also three directions, closely connected but not successive—in the activities and the life of Barthes: the polemical journalist immediately after the war, the triumphant yet marginal university professor of the postwar boom, and the elusive “novelist” celebrated by the entire intelligentsia of the left in the 1970s.

More than the details of these moments, it is important to note the intellectual influences that guided Barthes. He himself, in the “Phases” section of his pseudo-autobiography, *Roland Barthes par Roland Barthes*, played with establishing a correspondence of these stages (he counted two more) with an “intertext” of those who inspired him: Gide gave him the wish to write (“the desire for a work”); the trio Sartre-Marx-Brecht drove him to deconstruct our social mythologies (*Mythologies* was published in 1957); Saussure guided him in his work in semiology; the dialogue with Sollers, Kristeva, Derrida, and Lacan led him to take intertextuality as a subject; as for Nietzsche, his influence corresponded to the pleasure of writing during and about his last years, when he produced books dedicated to the enigma of pleasure: *L'Empire des signes* (1970), *S/Z* (1970), *Sade, Fourier, Loyola* (1971), and *Fragments d'un discours amoureux* (1977). *La Chambre claire* (1980), written shortly after the death of his mother, offers a restrained emotional reading of the illusions of the resurrection of reality through photography and concludes with an alternative: accept the spectacle of the false, or “confront untreatable reality.”

This represents a program of investigation, both political and aesthetic, that all the works and the very life of Barthes seem to have put into practice, even includ-

ing the part of his work devoted to speaking about clothes and fashion, “stable ephemera.”

### Genealogy of an Interest

It has been little noticed how early Barthes developed a curiosity about clothing (at least the clothing of others), about its communicative functions, and about the problems of approach and reconstruction to which those functions give rise. His contribution was that of a student of sociology, considering a massive and poorly understood phenomenon that had been seldom studied in France. This contribution could be decoded on many levels, but it was also that of an aesthete, enamored with the feel of fabrics and the flaring of a white dress on the beach at Bayonne in the 1930s. This is the image—a blurry photograph of his mother—that opens (and closes on “a moment of pleasure”) the introduction to *Roland Barthes par Roland Barthes*. Here, it is difficult to avoid noticing the trace of a nostalgic identification with the mother and a personal dandyism maintained with and by discreet and elegant companions. D. A. Miller (1992) may be right to regret that this genealogy, in part based on an unequivocal homosexuality (“L’adjectif,” “La déesse H.,” “Actif/Passif,” and other vignettes in *Roland Barthes*), was never made explicit or “brought out.”

However, attention to the body, to its costumes, and to the functions and imagery of those costumes, obsesses—literally—all aspects of the work of Barthes, and this is true beginning with his earliest theater criticism (“Les maladies du costume de théâtre” of 1955, reprinted in *Essais critiques* [1964]), and his various analyses of Brecht’s staging of *Mother Courage* from 1957 to 1960. As late as 1980, some fashion details of the photographs illustrating his last book, *La Chambre claire*, become the focus of his reflective emotion and serve as a *punctum*.

In parallel, as early as 1957, he published in *Annales* the seminal article “Histoire et sociologie du vêtement,” followed in 1960 by “Pour une sociologie du vêtement,” and in 1959, *Critique*, under the title “Langage et vêtement,” he published his review of books by J. C. Flügel, F. Kiener, H. H. Hansen, and N. Truman, writers then unknown to French specialists in the field. Other articles, such as “Le bleu est à la mode cette année” (*Revue française de sociologie*, 1960), “Des bijoux aux bijoux” (*Jardin des Arts*, 1961), and “Le dandysme et la mode” (*United States Lines Paris Review*, July 1962) exhibit the development of a semiological approach to clothing and the concern for a multifaceted way of writing able to adapt with virtuosity to diverse audiences. For example, he published in the women’s magazine *Marie-Claire* (1967) “Le match Chanel-Courrèges,” an article similar to one of the last of the *Mythologies*. Finally, although after that date, the language connected to fashion was no longer directly questioned, the last lines of *Roland Barthes* are still concerned with the weight of appearances: “Writing the body. Neither the skin, nor the muscles, nor the

bones, nor the nerves, but the rest, a clumsy, stringy, fluffy, frayed thing, the cloak of a clown.”

### For a Systemic Approach to Fashion

*Le Système de la mode* (1967) is an austere and baroque book that came out of a planned thesis, in which a linguistic theory (“the dress code”) develops, flourishes, and self-destructs. The book’s luxurious jargon and absence of iconography has repelled many and led to various misunderstandings. Its author—famous and praised for other more “literary” publications—plays the role of the proponent of a hard and fast scientism, which he nevertheless declares in the preface is already outdated. He counters and even contradicts this by embellishing the text with precious formulations (“Le bleu est à la mode”), and with a second part (one fourth of the book) unexpected in a work with a methodological purpose: an essay on the rhetoric of fashion journalists along with caustic sociological commentary. “Fashion makes something out of nothing,” and that “something” is first of all words, as Stéphane Mallarmé had shown. Hence, it is only the vocabulary and syntax of the captions for fashion pictures presented in the magazines of the 1960s that form the basis for the analyses—legitimately linguistic—offered by *Le Système*.

One should never forget that this was a practical exercise: the ingenious and inventive application of a new technique of reading (semiology) to a limited object but one requiring the creation of novel concepts. Those limits, explicitly set out by Barthes in his book and in contemporaneous interviews, were not understood by many readers who criticize the book for not speaking directly of the non-verbal communication carried out through clothing. Barthes is interested neither in clothing as artifact (clothing as made) nor in its figurative representations (iconic clothing), although those diverse subjects were part of the research program—too broad but more cautious on questions of linguistic analogy—proposed by the 1957 article. His aim is thus to find out “what happens when a real or imaginary object is converted into language” and thus becomes literature capable of being appropriated.

This lack of understanding—often unrecognized—and various ambiguities of expression making a faithful translation difficult, explain in part the delay of the book’s publication in English (1985), and a limited reception (in quantity and quality), which needs, however, to be analyzed country by country and generation by generation. The book nevertheless remains an essential reference, at least in France, for sociologists and historians of clothing, but even, or perhaps especially, there, *Le Système* has not acquired a following, except among a few French ethnologists, like Yves Delaporte, Jeanne Martinet, and Marie-Thérèse Duflos-Priot, who do not restrict themselves to studying “spoken,” that is, written clothing. It is a fashionable reference in a bibliography, but it has not really been assimilated, even though it has inspired sev-

eral descriptive systems of clothing used by museums and it has provided a number of convenient metaphors for experts in fashion.

As Barthes wished, the book has to be read first of all as a historical monument, a dated polemic, focused on methodological questions. But it is also a book in which one may take pleasure in digressing, while acquiring expertise and understanding about the state of fashion rhetoric in the 1960s, the state of innovative practices linked to structuralism, and also the state of French backwardness in research on clothing and the still novel efforts to introduce into the field the indispensable theory required for any study of a cultural phenomenon. The phraseology of the fashion magazine signifies a “fashionable” representation of reality, the ideology of which is unveiled by breaking it down into subsets and elements and by the concomitant variations (combined or opposed) of signifier and signified: “A cardigan is sporty or formal depending on whether the collar is open or closed.”

Barthes was a pioneer by rejecting the elitist linearity and the facile psychologism of “histories of costume,” by engaging in contemporary, not nostalgic, analysis of consumerist ideologies, and by carrying out high-risk interdisciplinary work taking into account individual choices and collective tendencies, the *longue durée* and differential rhythms of transformation of forms and customs, as well as the ephemeral character of the analyses of those who produced them: all knowledge is by definition “Heraclitean.” Even more, *Le Système de la mode* should be seen as an invitation to dissect (or possibly deconstruct) the discourse on other discourses that we fabricate with respect to all our objects of investigation. It should be done without illusions, but always with seriousness and irony.

See also **Fashion, Historical Studies of; Fashion, Theories of.**

### BIBLIOGRAPHY

- Barthes, Roland. *Œuvres complètes*. 3 vols. Paris: Seuil, 1993–1995.
- . *The Fashion System*. New York: Hill & Wang, 1983.
- Boulwood, Anne, and Robert Jerrard. “Ambivalence, and Its Relation to Fashion and the Body.” *Fashion Theory* 4, no. 3 (2000): 301–322.
- Delaporte, Y. “Le signe vestimentaire.” *L’Homme* 20, no. 3 (1980): 109–142.
- Delaporte, Y., ed. “Vêtement et Sociétés 2.” *L’Ethnographie* 130, nos. 92, 93, 94 (1984). Special issue.
- Fages, Jean Baptiste. *Comprendre Roland Barthes*. Toulouse, France: Privat, 1979.
- Harvey, John. *Men in Black*. Chicago: University of Chicago Press, 1995.
- Hollander, Anne. *Seeing Through Clothes*. Berkeley: University of California Press, 1993.
- Martinet, J. “Du sémiologique au sein des fonctions vestimentaires,” *L’Ethnographie* 130, nos. 92, 93, 94 (1984): pp. 141–251.

Miller, D. A. *Bringing Out Roland Barthes*. Berkeley: University of California Press, 1992.

Stafford, Andy. *Roland Barthes, Phenomenon and Myth: An Intellectual Biography*. Edinburgh: Edinburgh University Press, 1998.

Wilson, Elizabeth. *Adorned in Dreams: Fashion and Modernity*. London: Virago, 1985. Rutgers University Press issued a revised edition in 2003.

Nicole Pellegrin

**BATIK** Batik is one form of a process known as resist dyeing, in which the surface design on cloth is applied with a semifluid substance (wax, in the case of batik) that resists dye. When the substance is removed the resulting “negative space” or motif contrasts with the dye. Repeated applications of resist and dye create a complex design. Resist dyeing has a broad geographic distribution, historically found on all continents except for the Pacific Islands and Australia. The resist substances include mud, pastes (rice, peanut, cassava, or bean), starch, hot resin, paraffin, and beeswax. Monochromatic palettes of white (cloth color) and dark brown such as the bogolan mud cloths of Mali, or white and indigo as in the batiks of the Blue Hmong are common, and motifs tend to be geometric such as those found in West Africa, Turkistan, the Middle East, mainland Southeast Asia, and south China. In Indonesia, particularly on Java, batik developed intricate styles not found elsewhere, and its sophistication is mirrored in the use of batik cloths in Indonesian dress.

### Method

The rise of fine batik in Indonesia hinged on the availability of imported high thread count cotton fabric from Europe after the industrial revolution. Women create resist patterns on this cloth by gliding molten hot wax from a copper stylus called a *canting*, which just barely touches the cloth; coarse cloth would cause snags and wax drips. Both the surface and the underside of the cloth are waxed, so that the pattern is complete on both sides of the cloth. After each waxing, the cloth is dyed, and then boiled to remove the wax. Then another element of the design is waxed and the process repeats. The use of a stylus to create a hand-drawn batik pattern is called *tulis* (“writing”); the creation of *tulis* batik takes as much as two weeks for the waxing and a little over a month by the time the final dye bath is completed. Care must be taken to keep from cracking the wax, as this indicates poor craftsmanship.

Toward the middle or end of the nineteenth century, Chinese batik makers on the north coast of Java designed a type of copper stamp called *cap* (pronounced chop), a configuration of needles and sheet metal strips which was pressed into a hot wax stamp pad and used to transfer the wax to the cloth. *Caps* were paired as mirror images to wax the top and undersides of the cloth. *Cap* batik is a much faster process than *tulis*; a skilled worker can wax twenty cloths in a day.

### Design Motifs

Classical batik designs from central Java can be grouped in four categories; three are strongly geometric and the fourth is more organic. The first is the *garis miring* of diagonally running designs such as *parang rusak* (“broken knife”). The second is *nitik*, consisting of small dots or scallops as filler in large designs; this pattern imitates the visual effect of woven cloth. The third is *ceplok* which has grid-formed designs inspired by rosettes and cross-sections of fruit. The fourth is the *semen* category of styled flora and fauna motifs.

In general, batik designs from the north coast tend to be more organic with mammal, sea creature, bird, insect, and floral themes. These batiks are also more colorful. Traditional batiks from central Java tend to have muted colors of indigo, browns, creams, and whites in geometric motifs. A few, such as the *parang rusak*, were restricted for use only in the royal palaces of Yogyakarta, Surakarta, and other central Javanese royal courts, but over time those sumptuary laws have fallen by the wayside.

### Motif Placement and Dress

Batik on apparel involves strategic placement of multiple motifs, as can be seen from an examination of different garments: a head cloth (*iket kepala*), shawl (*slendang*), two kinds of wrapped skirts (*kain panjang* and *sarong*), and drawstring pants (*celana*). The head wrapper, worn by men, is about three feet long; it is a batik item that is produced in Java and worn throughout Indonesia. The inner area is a diamond shape, which may be solid or batiked. The outer part of the cloth is decorated with various motifs, with an ornate border that includes imitation fringe lines. It is possible for a head cloth to have different motifs in each quadrant, allowing for a high degree of decorative variety all in one head cloth.

Like the head cloth, the *slendang* or shoulder cloth can have borders and imitation fringe. There are many sizes; one for carrying children is about eighteen inches by seven and a half feet. Some may have one batik motif all over, or others might have each end specially decorated with *tumpal* (triangle) and other border motifs.

The *kain panjang*, a skirt wrapper about 250 centimeters long, may be covered with an all-over motif, or it may have narrow bands at the top and bottom. Sometimes *kain panjangs* are batiked with two contrasting patterns, called *pagi-sore* (morning-afternoon), an ingenious and efficient use of space because it allows a single length of cloth to serve as, in effect, two outfits. The cloth design is applied in the form of two triangles, so that as the cloth is wrapped about the body, only one design will show.

The sarong is shorter than the *kain panjang* (up to 220 centimeters in length) and sewn into a tube. Whereas the *kain panjang* was linked to central Java and the palaces there, the sarong was the regional dress of the north coast of Java, but eventually came to be used widely in Indonesia as informal dress. At the turn of the twentieth





**A textile worker creates a batik in Malaysia.** Classical batik designs were geometric and organic in nature. Diagonal lines, small dots, florals and fauna motifs were common in central Java. Batik designs from the north coast illustrated sea creatures, insects and floral themes. © CHARLES O'REAR/CORBIS. REPRODUCED BY PERMISSION.

century, Eurasian female entrepreneurs developed colorful Pekalongan-style batiks (named for a town on the northern coast of Java) with a tripartite layout. Floral borders (*pinggir*) lined the top and bottom of the textile, often with the lower border as the wider one. At one end was a wide panel (*kepala*) whose ground and motif contrasted with the body or rest of the textile (*badan*). The lower floral border framed the *kepala* on both sides. In general, the *badan* and *pinggir* were made with a *cap*, but the floral bouquet in the *kepala* would have been drawn by hand (*tulis*). As sewn into a sarong, the *kepala* worn in front would be shown to its fullest advantage.

That Pekalongan sarongs reflected Dutch floral and other themes was no accident. In the early years of Dutch colonization of Java, Dutch men married Javanese and Chinese women, who wore *kain-kebaya* (blouse-jacket with *kain panjang* or sarong). The women and children were Dutch citizens and at social events women wore *kain-kebaya*, showing off their prized Pekalongan batiks. In time the longish *kebaya* shortened to hip length to better display the *kepala* and *badan* of the batik wrappers. In the early twentieth century, more Dutch women joined husbands or married Dutch husbands in Java and also adopted the *kain-kebaya* as a practical alternative to the tailored European dress. Yet in the 1920s, as European racial attitudes hardened in the colonies, European women sought to differentiate themselves from Eurasian women and so tended increasingly to wear tropical-style European dress in public venues.

Batik drawstring pants (*celana*) were similarly tied to the dynamics of ruler and ruled. The origin of batik pants is not clear, but they seem to have been modeled after pants for little Chinese boys. Chinese and Dutch men found batik pants both exotic and comfortable, and the

pants were in use in the 1870s if not earlier. Dutch men favored them as loungewear in the privacy of their home, while their wives relaxed in *kain-kebaya*. Photographic evidence shows that the wearing of batik pants by adult men and children spread at least to Sumatra. The batik pants were made from a batik cloth or were made into pants from plain cloth first, then batiked. Batiks with border bands were incorporated in the batik pants by becoming the “cuff” of the pants. For taller individuals, an extension band of white fabric was sewn to the top of the batik pants; the band would be hidden under a shirt or jacket.

### Batik and World Dress

In the 1970s the competition from cheaper screen-printed imitation batik led to two developments: the batik shirt and *tulis* batik as couture. The governor of Jakarta, Ali Sadikin, proposed that a collared, long-sleeved button shirt in batik would be an acceptable formal alternative to the three-piece suit and hoped this strategy would vitalize the batik industry. The batik shirt became the ubiquitous dress for the urban Indonesian male. In the second development, batik designer Iwan Tirta created couture lines in *tulis* by producing the textiles on silk (instead of cotton) and reworking traditional motifs through size, color, and gold enhancement. If Tirta began with a flat batik cloth with an overall pattern and border, the border might be seen at the hem or sleeve; Tirta made use of the whole cloth. Both Sadikin and Tirta helped to create new dress styles for Indonesians and to give Indonesian batik a place in world fashion.

See also **Dyeing, Resist.**

### BIBLIOGRAPHY

- Djumena, Nian S. *Batik dan Mitra, Batik and its Kind*. Jakarta: Djambatan, 1990.
- Elliot, Inger McCabe. *Batik: Fabled Cloth of Java*. New York: Clarkson N. Potter, Inc., 1984.
- Larsen, Jack Lenor. *The Dyer's Art: Ikat, Batik, Plangi*. New York: Van Nostrand Reinhold Company, 1976.
- Schulte Nordholt, Henk, ed. *Outward Appearances: Dressing State and Society in Indonesia*. Leiden, The Netherlands: KITLV Press, 1997.

Heidi Boehlke

**BATISTE.** See **Cambric, Batiste, and Lawn.**

**BAUDELAIRE, CHARLES** Charles-Pierre Baudelaire (1821–1867) was perhaps the greatest French poet of the nineteenth century. He is most famous for a volume of poetry, *Les fleurs du mal* (Flowers of evil), published in 1857, which was prosecuted for blasphemy as well as obscenity. Baudelaire was also an important art critic and translator. He appears in an encyclopedia of

fashion because he proved to be an influential theorist of fashion and dandyism.

In his youth, Baudelaire devoted considerable time and money to his appearance. At a time when the masculine wardrobe was becoming ever more sober, he adopted an austere form of dandyism that was neither foppish nor bohemian. Whereas many of his contemporaries deplored the trend toward dark, severe clothing for men, he embraced and even exaggerated the style by wearing all-black clothing. But dandyism involved more than clothing for Baudelaire; he would certainly not have agreed with Thomas Carlyle's definition of the dandy as "a clothes-wearing man." Although Baudelaire's poetry does not touch on dandyism per se, he explored the topic both in his intimate journals, under such headings as "The eternal superiority of the Dandy. What is the Dandy?", and in two of his most famous essays, "On the Heroism of Modern Life," a section of his *Salon of 1846*, and *The Painter of Modern Life* (1863).

The modernity of dandyism is central to Baudelaire's analysis. Dandyism, he wrote, "is a modern thing, resulting from causes entirely new." It appears "when democracy is not yet all-powerful, and aristocracy is just beginning to fall." Like many artists during the nineteenth century, Baudelaire was ambivalent about the rise of democracy and capitalism. He described contemporary middle-class masculine attire as "a uniform livery of affliction [that] bears witness to equality." It was, he suggested, "a symbol of perpetual mourning." On the other hand, Baudelaire insisted that one should be of one's own time. "But all the same, has not this much-abused garb its own beauty?" The modern man's frock coat had both a "political beauty, which is an expression of universal equality," and also a "poetic beauty."

In place of the equality which modern men's uniform attire seemed to proclaim, Baudelaire suggested that dandyism announced a new type of intellectual elitism. "In the disorder of these times, certain men . . . may conceive the idea of establishing a new kind of aristocracy . . . based . . . on the divine gifts which work and money are unable to bestow. Dandyism is the last spark of heroism amid decadence." Baudelaire's modern dandy eschewed not only the foppish paraphernalia of prerevolutionary aristocratic dress, but also denied the bourgeois capitalist dominance of wealth. The Baudelairean dandy was not just a wealthy man who wore fashionable and expensive dark suits.

"Dandyism does not . . . consist, as many thoughtless people seem to believe, in an immoderate taste for . . . material elegance," declared Baudelaire. "For the perfect dandy these things are no more than symbols of his aristocratic superiority of mind. Furthermore, to his eyes, which are in love with distinction above all things, the perfection of his toilet will consist in absolute simplicity." Part of Baudelaire's minimalist aesthetic involved the elimination of color in favor of black, a noncolor that remains strongly associated with both au-

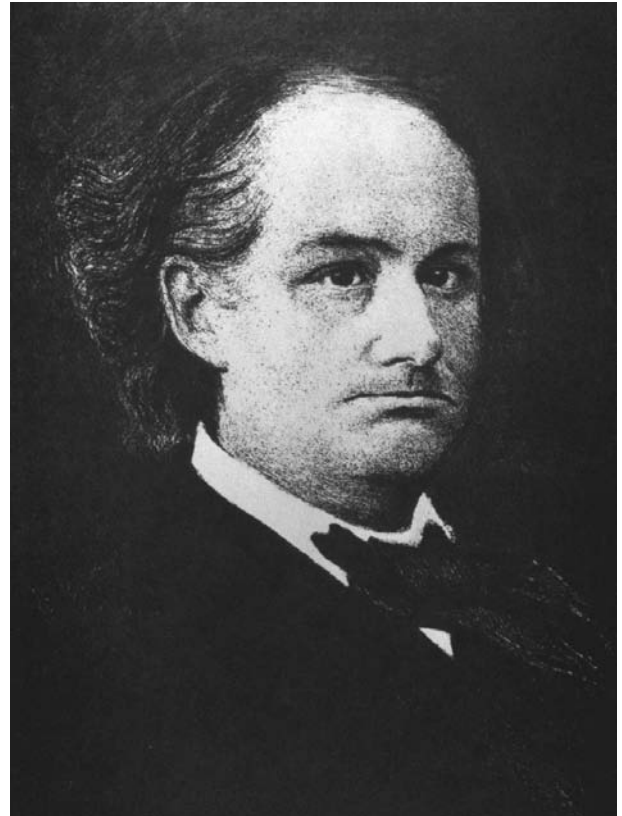

**French poet Charles Baudelaire.** Baudelaire's essays emphasized the relationship between fashion, modern life, and art. He related the transitory nature, or constant change of fashion, as the hallmark of modernity. THE LIBRARY OF CONGRESS. PUBLIC DOMAIN.

thority and rebellion, as witnessed by the following lines from Quentin Tarantino's film *Reservoir Dogs*:

MR. PINK: Why can't we pick out our own color?

JOE: I tried that once. It don't work. You get four guys fighting over who's gonna be Mr. Black.

If modern men's clothing—and still more so the clothing of the dandy—was characterized by simplicity, the same could not be said of nineteenth-century women's fashion, which was highly complicated and decorative. It was only in the twentieth century that such women as Coco Chanel created a radically simplified style of female fashion epitomized by the little black dress. Indeed, it could be said that Chanel was one of the first female dandies. Yet Baudelaire's attitudes toward women are problematic for modern feminists. "Woman is the opposite of the dandy," declared Baudelaire, because she is "natural." Only to the extent that she creates an artificial persona through dress and cosmetics is she admirable, and, even then, Baudelaire describes her as "a kind of idol, stupid perhaps, but dazzling."

Putting aside his ambivalence towards women, Baudelaire analyzed fashion in ways that illuminate both modern life and modern art. In particular, his essay *The*

*Painter of Modern Life* was one of the first and most penetrating analyses of the relationship between *la mode* (fashion) and *la modernité* (modernity). For Baudelaire, fashion was the key to modernity, and one simply could not paint modern individuals if one did not understand their dress. Baudelaire argued that it was simply “laziness” that led so many artists to “dress all their subjects in the garments of the past.” “The draperies of Rubens or Veronese will in no way teach you how to depict . . . fabric of modern manufacture,” he wrote. “Furthermore, the cut of skirt and bodice is by no means similar. . . . Finally, the gesture and bearing of the woman of today gives her dress a life and a special character which are not those of the woman of the past.”

According to Baudelaire, there were two aspects to beauty—the eternal and the ephemeral. The fact that fashion was so transitory, constantly changing into something new, made it the hallmark of modernity. The modern artist, whether painter or poet, had to be able “to distill the eternal from the transitory.” As Baudelaire wrote, “What poet would dare, in depicting the pleasure caused by the appearance of a great beauty, separate the woman from her dress?”

As a theorist of fashion, Baudelaire moved far beyond such other dandies and writers of his era as George (“Beau”) Brummell, Jules Barbey d’Aureville, and Théophile Gautier. He inspired such modernist poets as Stéphane Mallarmé and such philosophers as Georg Simmel and Walter Benjamin. Indeed, it is virtually impossible to imagine the modern study of fashion without taking account of Baudelaire’s contribution.

See also Benjamin, Walter; Brummell, George (Beau); Dandyism; Fashion, Theories of; Little Black Dress; Mallarmé, Stéphane; Simmel, Georg; Wilde, Oscar.

#### BIBLIOGRAPHY

- Baudelaire, Charles. *The Painter of Modern Life and Other Essays*. Edited and translated by Jonathan Mayne. London: Phaidon Press Ltd., 1964.
- Lehmann, Ulrich. *Tigersprung: Fashion in Modernity*. Cambridge, Mass.: MIT Press, 2000.
- Moers, Ellen. *The Dandy: Brummell to Beerbohm*. London: Secker and Warburg, 1960.
- Steele, Valerie. *Paris Fashion: A Cultural History*. 2nd ed. New Haven, Conn.: Berg, 1999.

Valerie Steele

**BAUDRILLARD, JEAN** The French intellectual Jean Baudrillard (b. 1929) is widely acclaimed as one of the master visionary thinkers of postmodernism and post-structuralism. He was trained as a sociologist, and his early critique was influenced by a certain style of radicalism that appeared in France after 1968, which included critical challenge to the disciplines, methods, theories, styles, and discourses of the academic intellectual establishment. After the late 1960s Baudrillard’s social theory

witnessed major paradigm shifts. The theory of consumption that he began to articulate in the 1970s foresaw the development of consumer society, with its dual focus first on the visual culture (material objects) and, later, on the virtual (electronic and cyberspace) culture.

Baudrillard’s fashion-relevant theorizing dates from his earlier writing: it forms part of his broader analysis of objects in consumer society. This scheme postulated a transition from “dress,” in which sartorial meaning (of differentiation and distinction) resided in natural signs, through “fashion,” in which meaning resided in oppositional (structuralist) signs, to “post-fashion,” in which signs are freed from the link to referents and to meaning (poststructuralist). Baudrillard’s early work is divided into three phases: (a) the reworking of Marxist social theory, as evident in *The System of Objects* (1968), *The Consumer Society* (1970), and *For a Critique of the Political Economy of the Sign* (1972) and with an emphasis on the “sign”; (b) a critique of Marxism, as seen in *The Mirror of Production* (1975) and *Symbolic Exchange and Death* (1976), where Baudrillard substitutes symbolic exchange for utilitarian exchange as an explanation of consumerism; (c) a break with Marxism, as manifest in *Seduction* (1979), *Simulations* (1983), *Fatal Strategies* (1983), and *The Transparency of Evil: Essays on Extreme Phenomena* (1993), which substitutes the carnival-esque principle (celebration, pleasure, excess, and waste) for the utility principle.

#### Signification

Initially, Baudrillard argued that when products move from the realm of function (reflecting use value and exchange value) to the realm of signification (reflecting sign value), they become carriers of social meaning. Specifically, they become “objects.” Baudrillard’s notion of sign value is based on an analogy between a system of objects (commodity) and a system of sign (language). He applied Ferdinand de Saussure’s structural linguistics to the study of fashion, media, ideologies, and images. If consumption is a communication system (messages and images), commodities are no longer defined by their use but by what they signify—not individually but as “set” in a total configuration. The meaning of signs, according to de Saussure, is made up of two elements: *signifiers* (sound images), which index the *signifieds* (referent). Saussurian structural linguistics is based on two principles: a metaphysics of depth and a metaphysics of surface. The metaphysics of depth assumes that meaning links a signifier with an underlying signified. The metaphysics of surface implies that signs do not have inherent meaning but rather gain their meaning through their relation to other signs.

Using a linguistic (semiotic) analogy to analyze commodities, Baudrillard developed a genealogy of sign structures consisting of three orders. The first order, founded on *imitation*, presupposes a dualism where appearances mask reality. In the second order, founded on *production*, appearances create an illusion of reality. In the third order, founded on *simulation*, appearances invent re-



Signification				
Order of Simulacra	Metaphor	Corresponding Stage of European Fashion	Metaphysical Analogy	Signification Order
Imitation	Counterfeit	Premodern stage	Metaphysics of depth	Direct signifier-signified links
Production	Illusion	Modern stage	Metaphysics of depth	Indirect signifier-signified links
Simulation	Fake	Postmodern stage	Metaphysics of surface	Signifier-signifier links

**Social meaning in products.** Products that served as function, reflecting use and exchange value, but came to reflect sign value, Baudrillard believed, carried social meaning. He used Ferdinand de Saussure's structural linguistics to study fashion, media, ideologies, and images.

ality. No longer concerned with the real, images are reproduced from a model, and it is this lack of a reference point that threatens the distinction between true and false. There are parallels between Baudrillard's historical theory of sign structures and historical theorizing of European sartorial signification. The order of imitation corresponds to the premodern stage, the order of production corresponds to the modern stage, and the order of simulation corresponds to the postmodern stage.

**Premodern stage.** Throughout European fashion history the scarcity of resources symbolized rank in dress. Costly materials were owned and displayed by the privileged classes. Technological and social developments from the fourteenth century onward challenged the rigid hierarchy of feudal society. This challenge triggered the legislation of sumptuary laws that attempted to regulate clothing practices along status lines by defining precisely the type and quality of fabrics allowed to each class. Since styles were not sanctioned by law, toward the end of the fourteenth century clothes began to take on new forms. This tendency set in motion a process of differentiation (along the lines of Georg Simmel's "trickle-down theory" of fashion), whereby the aristocracy could distinguish itself by the speed with which it adopted new styles.

**Modern stage.** The technological developments that characterized industrial capitalism (among them, the invention of the sewing machine and wash-proof dyes), popularized fashion by reducing the price of materials. Mass production of clothes increased homogeneity of style and decreased their indexical function. The industrial revolution created the city and the mass society, improved mobility, and multiplied social roles. A new order was created in which work (achieved status) rather than lineage (ascribed status) determined social positioning. Uniforms were introduced to the workplace to denote rank, as dress no longer reflected rank order (but instead defined time of day, activities, occasions, or gender). As a result, a subtle expert system of status differentiation through appearance between the aristocracy and "new money" evolved. This system coded the minutiae of appearance and attributed symbolic meanings that reflected a person's character or social standing. It also anchored certain sartorial practices to moral values (for example, the notion of *noblesse oblige*).

**Postmodern stage.** Postmodernism denotes a radical break with the dominant culture and aesthetics. In architecture it represented plurality of forms, fragmentation of styles, and diffuse boundaries. It has substituted disunity, subjectivity, and ambiguity for the modernist unity, absolutism, and certainty. In the sciences it stands for a "crisis in representation." This challenge to the "correspondence theory of truth" resulted in totalizing theories of universal claims giving way to a plurality of "narrative truths" that reflect, instead, the conventions of discourse (for example, rules of grammar that construct gender, metaphors and expressions encode cultural assumptions and worldview, notions of what makes a "good" story). The postmodern cultural shift has left its mark on the fashion world through its rejection of tradition, relaxation of norms, emphasis on individual diversity, and variability of styles.

Baudrillard characterized postmodern fashion by a shift from the modern *order of production* (functionality and utility) to the aristocratic *order of seduction*. Seduction derives pleasure from excess (sumptuary useless consumption of surplus, such as is displayed by celebrities). Baudrillard posits seduction as a system that marks the end of the structuralist principle of opposition as a basis for meaning. His notion of seduction is that of a libido that is enigmatic and enchanted. It is not a passion for desire but a passion for games and ritual. Seduction takes place on the level of appearance, surface, and signs and negates the seriousness of reality, meaning, morality, and truth.

**Analysis.** Analysis of the three stages of sartorial representation in terms of Baudrillard's signification relations produces Figure 1. In the order of *imitation* that characterized the premodern stage, clothes refer unequivocally to status. They signify the natural order of things without ambiguity. The order of *production* characterized the modern stage, where mass-produced clothes ceased to be indexical of status. It became important to establish whether people were what they claimed to be or rather were just pretending. In the orders of imitation and production, the signifier indexes an underlying meaning, either inherent or constructed. In contrast, the order of *simulation* refers to the principle of the postmodern dress that is indifferent to any traditional social order and is completely self-referential, that is, fashion for its own

sake. For Baudrillard, the effacing of real history as a referent leaves us nothing but empty signs and marks the end of signification itself. In sum, as simulation substitutes for production, it replaces the linear order with a cyclical order and frees the signifier from its link to the signified. Thus, fashion as a form of pleasure takes the place of fashion as a form of communication.

See also Benjamin, Walter; Brummell, George (Beau); Fashion, Theories of; Mallarmé, Stéphane; Simmel, Georg; Wilde, Oscar.

#### BIBLIOGRAPHY

- Baudrillard, Jean. *The Mirror of Production*. Translated by Mark Poster. St. Louis, Mo.: Telos Press, 1975.
- . *For a Critique of the Political Economy of the Sign*. Translated by Charles Levin. St. Louis, Mo.: Telos Press, 1981.
- . *Simulations*. Translated by Paul Foss, Paul Patton, and Philip Beitchman. New York: Semiotext(e), 1983.
- . *Fatal Strategies*. Translated by Philip Beitchman and W. G. J. Niesluchowski. New York: Semiotext(e), 1990.
- . *Seduction*. Translated by Brian Singer. New York: St. Martin's Press, 1990.
- . *Symbolic Exchange and Death*. Translated by Iain Hamilton Grant. Thousand Oaks, Calif.: Sage Publications, 1993.
- . *The Transparency of Evil: Essays on Extreme Phenomena*. Translated by James Benedict. London and New York: Verso, 1993.
- . *The System of Objects*. Translated by James Benedict. New York: Verso, 1996.
- . *The Consumer Society: Myths and Structures*. Thousand Oaks, Calif.: Sage Publications, 1998.
- Works about Jean Baudrillard*
- Gane, Mike, ed. *Jean Baudrillard*. 4 vols. Sage Masters of Modern Social Thought. Thousand Oaks, Calif.: Sage Publications, 2000.
- Kellner, Douglas. "Baudrillard, Semurgy and Death." *Theory, Culture, and Society* 4, no. 1 (1987): 125–146.
- . *Jean Baudrillard: From Marxism to Postmodernism and Beyond*. Stanford, Calif.: Stanford University Press, 1989.
- Kellner, Douglas, ed. *Baudrillard: A Critical Reader*. Oxford and Cambridge, Mass.: Blackwell, 1989.
- Poster, Mark, ed. *Jean Baudrillard: Selected Writings*. Stanford, Calif.: Stanford University Press, 1988.

Efrat Tseïlon

**BEADS** In their simplest form, beads are small, perforated spheres, usually strung to create necklaces. They can be made of metal, pottery, glass, or precious or semi-precious stones, such as ivory, coral, turquoise, amber, or rock crystal, or glass. The human desire for personal ornamentation and decoration is clearly evident from the frequent presence of beads in archaeological sites. The earliest beads, dating from the Paleolithic period, were made mainly with seeds, nuts, grains, animal teeth, bones, and, most especially, sea shells. Indeed, like sea cowries, beads



**Rosary.** Created centuries ago by Christian monks to count prayers, rosaries have become a symbol of a committed spiritual life and are a common element in modern Christianity. © ROYALTY-FREE/CORBIS. REPRODUCED BY PERMISSION.

were used in barter and in ceremonial exchanges; they thus contain precious information on early trade routes.

Beads found in early Egyptian tombs are thought to date from about 4000 B.C.E. Faience (glazed ceramic) beads appeared in Egypt's predynastic period and continued to be made in Roman times. The Phoenicians and Egyptians also made fancy beads with human and animal faces. What were probably the earliest gold beads, going back to 3000 B.C.E., were found in the Sumerian and Indus valleys; gold beads of later date have been found in Ashanteland (Ghana) and other parts of Africa. Mycenaean beads found in Crete, dating from the Late Bronze Age (c. 1100 B.C.E), were fashioned in original floral shapes, such as lilies and lotuses, as well as granulated surfaces. Stone and shell beads, and from the fifteenth century C.E. on, glass beads, were worn in large quantities by American Indians.

Among some populations, beads are worn as much for magical as for decorative purposes. For example, in Middle Eastern and southern European countries, coral beads are thought to encourage fertility and are frequently an essential part of a woman's trousseau. Turquoise and blue-colored beads are attached to the clothes of brides and children, as well as to the collars of domestic animals—to hung to cars' viewing mirrors—to avert bad luck and illness. Amulets thought to have the power to avert impotence, loss of breast milk, or the alienation of a husband's affection, often include "eye beads" strung together with cowries: thanks to a subtle resemblance of openings and curved lines, the latter are understood to symbolically represent the eye as well as the female genitalia.

The word "bead" comes from the Middle English word "bede," which means pray, and beads strung to make rosaries have been used since the Middle Ages to count prayers. But even as strings of beads took on well-defined religious significance in Europe, they rapidly took on new meanings, as they were exported to diverse

cultures that had their own symbolic systems. Rosaries, which were among the earliest strings of crystal and glass beads exported from Venice in significant quantities by crusaders, soon became part of garments and ornaments related to entirely different belief systems and rituals. They were often used as counters in trade. Certain types of beads that acquired rarity value were removed from economic exchange cycles to become ancestral property, only changing hands as bride-wealth or used to validate claims to royal and aristocratic status.

European traders often exchanged beads for African or American Indian goods of very much greater value, such as gold or even slaves. According to traditional lore, the whole island of Manhattan was bought by Dutch settlers for the equivalent in beads of twenty-four dollars. The story—a foundation myth of the United States—is often told to show how the Indians were primitive and naive. But in reality, as research on different societies has shown, beads had been used in trade for centuries before the arrival of Europeans, and their value was determined by social consensus.

For many African populations, beads are important markers of identity. Beaded garments and hats are worn at all times, but most especially on ceremonial occasions. Young women make small bead jewels for their favorite boys. The contrast of different colors and shapes can give these jewels a variety of meanings and whites have described them as “love letters.” For some South African Kwa-Zulu women, who have developed remarkable skill in creating beaded figures or dolls dressed in ethnic costume, to sell to tourists in the vicinity of Durban, beadwork has become a useful source of income.

The use of beads for personal adornment, as well as for decoration of a variety of objects, has continued uninterrupted through history. They can be stitched or woven into textiles, used in embroidery, or applied to hats, belts, handbags, or to household objects, such as boxes or lampshades. American Indians have long applied vividly colored glass beads in original geometrical designs to leather clothing, bags, and leather boots.

While Venetians dominated the manufacture and export of glass beads from the fifteenth to the mid-twentieth century, by the early 2000s beads were made in all parts of the world. Since the 1960s, interest in the cultures and customs of third-world countries has led to a keen search for old beads on the part of museum keepers and antique dealers. This in turn has led to a revival in large-scale production and use of beads by the general public. Fashion items such as handbags, ladies' waistcoats, and belts vividly decorated with beads are made in China and other parts of the Far East.

Venetian beads, while not produced on as large a scale as they were in the past, remain very high quality, and the city's association with glass beads helps it maintain a lively second-hand and antique trade, as well as a strong interest in experimentation and creativity in the search for new versions of the traditional craft of making glass beads and



**Man working prayer beads.** For centuries beads have been an instrument of prayer. In Middle Eastern countries, as well as other parts of the world, strung beads help one keep one's place in structured prayer. © DAVID H. WELLS/CORBIS. REPRODUCED BY PERMISSION.

their use in personal ornaments. Beadwork, in particular the stringing of necklaces and bracelets, has become a widespread pastime, and shops with lively displays of beads, fine metal, or cotton and silk thread are found in almost every city. The low cost of beads in relation to jewelry makes them a very versatile ornamental element, often specially created to enhance a particular outfit or occasion.

See also **Costume Jewelry; Jewelry; Necklaces and Pendants; Spangles.**

#### BIBLIOGRAPHY

- Carey, Margaret. "Across the Atlantic: Beaded Garments Transformed." *Journal of Museum Ethnography* no. 14 (March 2002).
- Dubin, Lois Sherr. *The History of Beads from 30,000 B.C.E. to the Present*. New York: Harry N. Abrams, 1987.
- Eicher, Joanne B., and Barbara Sumberg. "World Fashion, Ethnic and National Dress." In *Dress and Ethnicity: Change across Space and Time*. Edited by Joanne B. Eicher. Washington, D.C.: Berg, 1995.
- Hughes-Brock, Helen. "The Mycenaean Greeks: Master Bead-Makers. Major Results Since the Time of Horace Beck."



- In *Ornaments from the Past: Bead Studies after Beck: A Book on Glass and Semi-Precious Stone Beads in History and Archaeology for Archaeologists, Jewelers, Historians and Collectors*. By Ian C. Glover, Helen Hughes-Brock, and Julian Henderson. London and Bangkok: Bead Study Trust, 2003.
- Israel, Jonathan I. *Dutch Primacy in World Trade, 1585–1740*. New York: Oxford University Press, 1989.
- Jones, Mark, ed. *Fake? The Art of Deception*. Berkeley: University of California Press, 1990.
- Karklins, Karlis. *Glass Beads*. 2nd edition. Ottawa: National Historic Parks and Sites Branch, 1985.
- Klump, D., and Corinne A. Kratz. "Aesthetics, Expertise, and Ethnicity: Okiak and Masai Perspectives on Personal Ornament." In *Being Maasai: Ethnicity and Identity in East Africa*. Edited by Thomas Spear and Robert Waller. Athens: Ohio University Press, 1993.
- Orchard, William C. *Beads and Beadwork of the American Indians: A Study Based on Specimens in the Museum of the American Indian*. New York: Museum of the American Indian, Heye Foundation, 1929.
- . "Transport and Trade Routes." In *The Cambridge Economic History of Europe*, vol. 4. Cambridge, U.K.: Cambridge University Press, 1967.
- Picard, John, ed. *Beads from the West African Trade*. 6 vols. Carmel, Calif.: Picard African Imports, 1986.
- Sciama, Lidia D., and Joanne B. Eicher, eds. *Beads and Bead Makers: Gender, Material Culture, and Meaning*. Oxford: Berg, 1998.
- Tomalin, Stefany. *Beads! Make Your Own Unique Jewelry*. New York: Sterling Publishing Company, 1988.
- . *The Bead Jewelry Book*. Chicago: Contemporary Books, 1998.
- Tracey, James D., ed. *The Rise of Merchant Empires: Long-Distance Trade in the Early Modern World, 1350–1750*. New York: Cambridge University Press, 1990.

Lidia D. Sciama

**BEARDS AND MUSTACHES** Because facial hair is strongly associated with masculinity, beards and mustaches carry powerful and complex cultural meanings. Growing a beard or mustache, or being clean-shaven, can communicate information about religion, sexual identity, and orientation, and other important aspects of cultural heritage.

In many cultures, the wearing (or not) of facial hair has been a marker of membership in a tribe, ethnic group, or culture, implying acceptance of the group's cultural values and a rejection of the values of other groups. This distinction sometimes admitted a certain ambiguity; in ancient Greece, a neatly trimmed beard was a mark of a philosopher, but the Greeks also distinguished themselves from the *barbaroi* ("barbarians," literally "hairy ones") to their north and east. In early imperial China some powerful men (magistrates and military officers, for example) wore beards, but in general hairiness was associated with the "uncivilized" pastoral peoples of the northern frontier; by later imperial times, most Chinese

men were clean-shaven. As Frank Dikotter puts it, "the hairy man was located beyond the limits of the cultivated field, in the wilderness, the mountains, and the forests: the border of human society, he hovered on the edge of bestiality. Body hair indicated physical regression, generated by the absence of cooked food, decent clothing and proper behaviour" (p. 52).

Conversely, in ancient Egypt beards were associated with high rank, and they were braided and cultivated to curl upward at the ends. False beards were worn by rulers, both male and female, and fashioned of gold. In the ancient Mesopotamian, Assyrian, Sumerian, and Hittite empires, curled and elaborately decorated beards were indicators of high social status while slaves were clean-shaven. In his book *Hair: The First Five Thousand Years*, Richard Corson analyzes the complexities of facial hair across history and points out that in the ancient world, "during shaven periods, beards were allowed to grow as a sign of mourning." Also, in a period of shaven faces such as early in the first century, "slaves were required to wear beards as a sign of their subjugation" but when free men wore beards in the second and third centuries slaves had to distinguish themselves free by shaving (p. 71). Long mustaches were the norm amongst Goths, Saxons, and Gauls and were worn "hanging down upon their breasts like wings" (p. 91) and by the Middle Ages again were a mark of noble birth.

Facial hair has been an issue for many religions. Pope Gregory VII issued a papal edict banning bearded clergymen in 1073. In Hasidic Jewish culture beards are worn as an emblem of obedience to religious law. Muslim men who shave their facial hair are, in some places, subject to intense criticism from more religiously conservative Muslims for whom growing a beard is an indication of cleanliness, obedience to God, and male gender. In some Muslim countries (such as Afghanistan under the Taliban), the wearing of untrimmed beards has been obligatory for men.

In Western culture in recent centuries, however, the wearing or shaving of facial hair has tended to become more a matter of fashion than of cultural identity. For most of history, the shaving of facial hair and the shaping of beards and mustaches has depended on the skills of barbers and personal servants who knew how to whet a razor and to use hot water and emollients to soften a beard. Jean-Jacques Perret created the first safety razor in 1770. It consisted of a blade with a wooden guard, which was sold together with a book of instruction in its use entitled *La Pogotomie* (The Art of Self-Shaving). In 1855 the Gillette razor was invented, the T-shape taking over from the cutthroat razor. Self-shaving became increasingly popular as the century progressed, especially after Gillette's further modification of his original design in 1895 with the introduction of the disposable razor blade.

The nineteenth and twentieth centuries have seen a myriad of different styles of beards and mustaches as fa-

cial hair took over as a focal point of male personal fashion, together with complementary hairstyles. Men might choose to wear their whiskers as muttonchops (so-called because of their shape), Piccadilly weepers (very long side-whiskers), Burnsidies (that eventually evolved into sideburns), or the short and pointed Vandyke beard (including to a style popular in Renaissance Holland). Full mustaches that grew down over the top lip were dubbed soup strainers.

Many products, such as tonics, waxes, and pomades, were developed to help groom and style facial hair, and small industries grew up to manufacture and distribute them. Stylish mustaches and beards could be a point of personal pride. Charles Dickens wrote of his own facial ornamentation, "the moustaches are glorious, glorious. I have cut them shorter and trimmed them a little at the ends to improve their shape" (Corson 1965, p. 405).

In much of western Europe and America, facial hair was considered dashing and masculine because of its long associations with the military. By the mid-nineteenth century, doctors warned men that the clean-shaven look could be deleterious to their health; for example, it was said that bronchial problems could result if a mustache and beard were not worn to filter the air to the lungs. Thus to be clean-shaven was almost an act of rebellion, taken at the end of the century by bohemians and artists such as Aubrey Beardsley and the playwright Oscar Wilde. By the 1920s, however, the clean-shaven look had taken hold in mainstream fashion. Facial hair then became a mark of rebellion or artistic self-definition. Salvador Dali confirmed his artist status with an elaborate waxed mustache by the late 1920s. Mustaches continued to be worn by military men, and this is reflected in the names of styles such as Guardsman, Major, and Captain.

The beard had become rare by the mid-twentieth century, and was thus taken up by young bohemians in the 1950s as a gesture of nonconformity. Beards continued as a countercultural statement in the late 1960s with the hippie movement, when many young men saw facial hair as a sign of "naturalness," or a gesture of admiration for revolutionaries such as Che Guevara and the Cuban leader Fidel Castro. Hells Angels and bikers added a leather-clad hypermasculinity to the beard. Bearded hypermasculinity also was embraced within some subsets of gay culture. By the 1970s the clone look emanating from the streets of San Francisco included tight jeans, short hair, and mustaches. This look was adopted in mainstream fashion as seen on the actor Tom Selleck in *Magnum P.I.*, a popular television program.

By the mid-1980s, in place of full beards or mustaches designer stubble became de rigueur for actors and male models, as seen on the face of the pop star George Michael and the actor Bruce Willis, an effect achieved by going unshaven for a day or two. The 1990s witnessed a renaissance of beards and stubble as a result of the grunge movement emanating from Seattle and the New Age

Traveler alliance in Europe. Both groups, one associated with rock music and the other with environmental protest, advocated a return to "authenticity" and eschewed regular shaving. Stubble and short beards appeared on the singer Kurt Cobain, front man for the band Nirvana. Swampy, a well-known British environmental protester, sported a head of dreadlocks and a matching "natural" beard in protest against environmental destruction.

The most popular contemporary permutations of facial hair are the goatee or love bud (in which a small patch of beard is allowed to grow below the lower lip). The full beard with side-whiskers, now found mainly on the faces of men who were young in the 1950s and 1960s, has been generally rejected by men of later generations, most of whom are clean-shaven.

See also **Fashion and Identity; Hairstyles.**

#### BIBLIOGRAPHY

- Corson, Richard. *Hair: The First Five Thousand Years*. London: Peter Owen, 1965.
- Dikotter, Frank. "Hairy Barbarian, Furry Primates, and Wild Men: Medical Science and Cultural Representations of Hair in China." In *Hair: Its Power and Meaning in Asian Cultures*. Edited by Alf Hiltebeitel and Barbara D. Miller. Albany: State University of New York Press, 1998.
- Peterkin, Allan. *One Thousand Beards: A Cultural History of Facial Hair*. Vancouver, Canada: Arsenal Pulp Press, 2001.

Caroline Cox

**BEATON, CECIL** Cecil Beaton (1904–1980) was one of the most original and prolific creative talents of the twentieth century. Born in London and educated at Harrow and Cambridge University, he worked not only as a fashion photographer but also as a writer, artist, and actor and in his primary field of interest as a stage and costume designer for ballet, opera, and theater. Beaton was a self-taught photographer: he was given a simple Kodak 3A camera for his twelfth birthday and soon was eagerly photographing his young sisters, Nancy and Barbara ("Baba"), in "period" costumes and sets he made from fish-scale tissues and pseudo-Florentine brocades, tinsel nets, and imitation leopard skins. His nanny developed his negatives in the bathtub. In 1927, at the age of twenty-three, he went to work for *Vogue* as a cartoonist, but he soon began freelancing as a photographer for Condé Nast Publications and *Harper's Bazaar*, taking fashion shots and portraits of royalty and personalities in the arts and literature.

#### Influences on Beaton

The most important influence on Beaton's fashion photography was his interest in stage design and theatrical production, in which he was extremely accomplished. He did costume design for the film *Gigi* and set and costume design for the play and the film *My Fair Lady*, receiving



**Cecil Beaton.** Beaton was a writer, artist, actor, and a costume and set designer for ballet and theatre, as well as a renowned self-taught fashion designer. He received two Oscars, one for costume design for the film *Gigi*, and the second for set and costume design for the play and film *My Fair Lady*. © JOHN SPRINGER COLLECTION/CORBIS. REPRODUCED BY PERMISSION.

Oscars for both. He also designed for the Metropolitan Opera, the Comédie Française, the Royal Ballet (London), and the American Ballet Theatre. “Completely stage struck” at an early age, he wrote in his *Photobiography* that he felt “a keen perverse enjoyment in scrutinizing photographs of stage scenery. The more blatantly these showed the tricks and artifices of the stage, which would never be obvious to a theatre audience, the greater my pleasure” (p. 16). This interest explains some of Beaton’s most unusual fashion photographs, which include hanging wires and large sheets of pasted paper as backdrops for high-fashion outfits.

Beaton also had an extensive knowledge of Victorian and Edwardian photography and drew for inspiration on the costume depiction of such nineteenth-century portrait photographers as Camille Silvy and the collaborators D. O. Hill and Robert Adamson. He was also inspired by the soft-focus technique of the photographer E. O. Hoppé, the opalescent lighting of Baron Adolf de Meyer, and conventions of English portraiture and Renaissance painting. Beaton combined these influences with his innate taste for Victorian surface ornamentation and opulent effects, or what the critic Hilton Kramer has termed “extravagant and overripe artifice” (p. 28).

Beaton first traveled to Hollywood in 1931, and the world of tinsel as well as the influence of surrealism he encountered there were well suited to his insatiable taste for the theatrical and exotic. “My first impressions of a film studio were so strange and fantastic that I felt I could never drain their photographic possibilities,” he wrote. “The vast sound stages, with the festoons of ropes, chains, and the haphazard impedimenta, were as lofty and awe-inspiring as cathedrals; the element of paradox and surprise was never-ending, and the juxtaposition of objects and people gave me my first glimpse of Surrealism” (*Photobiography*, p. 61).

Beaton began introducing strong shadows into his work, a motif he may well have borrowed from Hollywood productions. The use of such shadows was popular in movies and advertising photography of the 1930s, so much so that articles such as one entitled “Shadows in Commercial Photography” were devoted to it (Hall-Duncan, p. 61). A famous pair of pendant photographs taken by Beaton in 1935 each shows an elegant model attended by three debonair phantoms created by back-lighting three tuxedoed male models against a white muslin screen (Hall-Duncan, pp. 114–115).

#### **Beaton’s Work at *Vogue***

Returning to New York for his *Vogue* assignments in 1934, Beaton took his always fussy sets to a new level of fantastic overindulgence. He combed the antique shops of Madison and Third Avenues for carved arabesques, gesticulating cupids, silver studio work, and ceilings in imitation of the Italian rococo painter Giovanni Battista Tiepolo. “His baroque is worse than his bite,” was a comment heard around the Condé Nast studios.

At the same time, under the influence of surrealism, which advocated the surprising juxtaposition of objects as a way to release the subconscious, he began incorporating bizarre combinations that created some of the most unusual fashion photographs of the century. The commonest object became grist for Beaton’s creative mill: expensive gowns were posed against backgrounds of egg-beaters and cutlet frills, wire bedsprings, and kitchen utensils. Models appeared wearing hats composed of eggshells or carrying baskets of tree twigs. Beaton was even accused of using toilet paper, though his background was actually made of what is called “cartridge” paper.

The most extreme example was one that would have profound implications for fashion photography decades later, particularly in the work of Guy Bourdin and Deborah Turbeville. In 1937 Beaton discovered an office building under construction on the Champs-Élysées in Paris that revealed a “fantastic décor” (*Photobiography*, p. 73) of cement sacks, mortar, bricks, and half-finished walls. The resulting prints, in which Beaton showed mannequins nonchalantly reading newspapers or idling elegantly in this debris, were published with much hesitation on the part of the magazine’s editors. Yet even much later, as Beaton noted, “fashion photographers are still



searching for corners of desolation and decay, for peeling walls, scabrous bill-boardings and rubble to serve as a background for the latest and most expensive dresses" (*Photobiography*, p. 73).

By the middle of the 1930s Beaton was starting to be disturbed by *Vogue's* restrictions on his creativity. He was called into the *Vogue* offices for posing models in "unladylike" poses with their feet planted well apart. Then it was found that Beaton had incorporated anti-Semitic words into the border of a pen-and-ink sketch done for the February 1938 issue of *Vogue*. The offending line read, "Mr. R. Andrew's ball at the El Morocco brought out all the dirty kikes in town." The result, after 150,000 copies of *Vogue* were on newsstands, was catastrophic. Condé Nast recalled and reprinted 130,000 copies of the questionable issue and quickly issued a legal disclaimer. Walter Winchell wrote a snide review, as did many other columnists. As a result, Beaton "resigned." In time, the incident blew over and Beaton was reinstated at *Vogue*, where he continued to do fashion photography for several more decades. During World War II he was the official photographer to the British Ministry of Information, photographing the fronts in Africa and in the Near and Far East.

### Beaton's Importance

Beaton had a long and extremely productive career in fashion photography, costume, and set design and writing and illustrating many books with his own witty drawings, based on the detailed diaries he kept all his life. Yet his work is of uneven quality. "When Cecil Beaton is good," the photography critic Gene Thornton said, "he is very, very good, but when he's bad, he's horrid. . . . It takes a kind of genius to be that bad" (p. 33). Indeed, the excesses of Beaton's style can be cloying, naive, and even trite, but few have questioned the inventive range of work or the important influence it would have on subsequent fashion photographers, particularly in the 1970s.

See also **Fashion Photography; Film and Fashion; Theatrical Costume; Vogue.**

### BIBLIOGRAPHY

- Beaton, Cecil. *Photobiography*. London: Odhams Press, 1951.
- Danziger, James. *Beaton*. New York: Viking Press, 1980.
- Garner, Philippe, and David Alan Mellor. *Cecil Beaton: Photographs 1920–1970*. New York: Stuart, Tabori, and Chang, 1995.
- Hall-Duncan, Nancy. *The History of Fashion Photography*. New York: Alpine Book Company, 1979.
- Kramer, Hilton. "The Dubious Art of Fashion Photography." *New York Times*, 28 December 1975.
- Ross, Josephine. *Beaton in Vogue*. New York: Clarkson N. Potter, 1986.
- Thornton, Gene. "It's Hard to Miss with a Show of the '30s." *New York Times*, 18 April 1976.

Nancy Hall-Duncan

**BEENE, GEOFFREY** Geoffrey Beene was born Samuel Albert Bozeman Jr. in Haynesville, Louisiana, on 30 August 1927, into a family of doctors. He dutifully enrolled in the premed program at Tulane University in New Orleans in 1943. Three years later he dropped out of Tulane and enrolled in the University of Southern California, Los Angeles, to pursue his lifelong interest in fashion design. However, he never attended classes as he decided to accept a job working in the display department of the I. Magnin department store, and then moved to New York to study at the Traphagen School of Fashion. By 1948 Beene had moved to Paris, where he attended the École de la Syndicale d'Haute Couture, the traditional training ground for European fashion designers. He then served a two-year apprenticeship with a tailor from the couture house of Molyneux. Beene returned to New York in 1951 and worked for a series of Seventh Avenue fashion houses before being hired by Teal Traina in 1954. He remained at Teal Traina until 1963, when he decided it was time to strike out on his own, opening Geoffrey Beene, Inc., offering high-quality ready-to-wear women's clothing. Beene's business partner was Leo Orlandi, who had been the production manager for Teal Traina.

### An American Aesthetic

Beene started his career during the era when Parisian designers still dominated the fashion world and Americans were expected to look to them for inspiration. However, though Beene was trained in the traditional manner, educated in New York and Paris, he broke out of the mold after his training and apprenticeship working for other designers. His creativity and skill were soon rewarded with a Coty award in 1964, after just one year in business, thus beginning one of the most award-winning careers in American fashion. His first collection made the cover of *Vogue*, and he has been regarded as a dean of American design ever since. His high-profile clients have included several First Ladies, and he designed the wedding dress of President Lyndon B. Johnson's daughter, Lynda Bird Johnson, in 1967.

Beene's distinctive creative vision manifested itself fully in 1966 when he designed ballgowns using gray flannel and wool jersey. He went on to design a series of dresses inspired by athletic jerseys, most notably a sequined full-length football-jersey gown in 1968. Generally, his clothes did display a respect for traditional dress-making, which manifested itself in details such as delicate collars and cuffs, and minutely tucked blouses, applied to a paired-down silhouette.

By the mid-1970s Beene had a number of licensing agreements for products as diverse as eyeglasses and bed sheets. The Beene Bag line of women's wear, introduced in 1971, used the same silhouettes as his couture line, but he employed inexpensive fabrics such as mattress ticking and muslin. Everyday fabrics continued to make their way into his higher-priced line as they had since the late



**Evening dresses on display at a Geoffrey Beene showing.** Varied fabrics and colors are the hallmark of Geoffrey Beene's contemporary ball gown designs. Since his career began in the mid-1960s, the fashion designer experimented with common textures such as flannel, muslin and jersey to create sensual, comfortable evening wear. © REUTERS NEWMEDIA INC./CORBIS. REPRODUCED BY PERMISSION.

1960s, as he used sweatshirt fabric and denim for evening dresses in his 1970 collection.

Beene considers the years 1972–1973 as a turning point in his career. It was then that he set aside traditional Parisian tailoring methods and began to explore softer silhouettes. He commented on these years in the catalog to a 1988 retrospective of his work at the National Academy of Design:

At that time there was so much construction in my clothes they could stand alone. I believed inner structure and weight were synonymous with form and shape. My sketches were dictating the design, not the fabric. When I became aware that my clothes lacked

modernity, I began to experiment more with fabric, working with textile mills abroad, commissioning new weights, textures and fiber mixes. (Beene 1988, p. 4)

By 1975 Beene had been awarded a fifth Coty and had launched Grey Flannel, one of the first and perennially most successful designer men's fragrances. He was able to buy out his partner and obtain complete control over his business by the early 1980s.

### Influence Abroad

In 1976 Beene became the first American designer to show in Milan, Italy, set up manufacturing facilities there, and successfully compete in the European fashion market. This success led to his sixth Coty in 1977, which was awarded for giving impetus to American fashion abroad. It is the Coty award that he treasured most, as the challenge of success in Europe was significant to his development as an artist—he proved to himself that his designs and his unique American vision had validity in the international arena. The European success also brought the added benefit of prestige and significantly increased sales of the couture line in the United States. But by this point in his career, Geoffrey Beene Couture, Beene Bag, and two fragrances accounted for only one-third of Beene's sales; the remainder was from licensing royalties for Beene-designed men's clothes, sheets, furs, jewelry, and eyeglasses.

While Beene has always been regarded as a master of form silhouette, it has been his use of color and fabric mixtures that garner the most comment. In a 1977 article for *The New Yorker*, Kennedy Fraser stated: "The distinctive quality of Geoffrey Beene's work which at the same time reflects an immediate sensuous response to the color and texture of beautiful fabrics must be characterized as a variety of intellectualism" (Fraser, p. 181). His ability to push experiments with color and texture was remarked upon again by the *Cleveland Plain Dealer* in 1987: "In the hands of a less adept designer, a collection that encompasses everything from bedspread chenille and gold spattered faille or silver leather to monk's cloth would be a nightmare" (Cullerton, p. 181). Beene consistently revealed hidden characteristics of the fabrics that he chooses.

In 1982 Geoffrey Beene received his eighth Coty award—the most awarded to any one designer as of the early 2000s—and professional recognition continued through the 1980s as he was named Designer of the Year in 1986 by the Council of Fashion Designers of America.

The vocabulary of sportswear appeared consistently in Beene's work as he strove for a balance between comfort and style. During the 1980s, when jumpsuits began to appear frequently in his women's collection, he stated that "the jumpsuit is the ballgown of the next century." Neither hard-edged nor futuristic, Beene's jumpsuits emphasize the comfort and versatility of this form of garment. The same is true for his use of men's wear influences in women's wear—bow ties, vests, and suiting fabrics are used with whimsy.



**Geoffrey Beene selecting shoes.** Geoffrey Beene, a fashion designer whose career has spanned more than four decades, introduced an innovative mix of color and new fabrics to haute couture. His creations earned him eight prestigious Coty Awards. © DAVID LEES/CORBIS. REPRODUCED BY PERMISSION.

### Later Career

In 1988 a retrospective at the National Academy of Design opened to coincide with the anniversary of Beene's twenty-five years in business. During this time, an article appeared in the *Village Voice* by Amy Fine Collins, who took on the role of Beene's muse through the 1990s. In analyzing Beene's work as an artist, she focused on his seemingly contradictory combinations of materials and influences, praising his courage to "regularly descend into the depths of taste in order to reemerge with his vision replenished" (Fine Collins, p. 34). In 1988 the Council of Fashion Designers of America gave Beene a newly created award, the Special Award for Fashion as Art.

Beene continued his innovations with fabric, treating humble textiles regally and using luxurious materials with throwaway ease. For example, a 1989 sheared mink coat for the furrier Goldin-Feldman in a bathrobe-like silhouette was created in fur dyed hot pink, edged with electric blue ribbon in a giant rickrack pattern, and lined with an abstract print in coordinating colors.

The year 1989 saw the opening of Geoffrey Beene on the Plaza, Beene's flagship retail shop on Fifth Av-

enue. He envisioned the shop as a design laboratory where he could "put in something new and in a few days have enough feedback to know if it's a success or if it has to go back to the drawing board" (Morris, p. B11).

Beene had shown a special interest in lace, for its combination of sheerness and strength along with its ability to stretch. In the late 1980s he began utilizing strategically placed sheer and cutout panels, especially in his evening clothes, culminating in the matte-wool-jersey-and-sequins lace-insertion gowns of 1991, which exemplify the exacting cut and technical intricacy of his work. His spiraling designs, which consider the body in the round rather than using flat pieces and treating the front and back as separate entities, reveal his admiration for and study of the work of the French couturier Madeleine Vionnet.

In 1994 Beene was honored again with an exhibition at the Fashion Institute of Technology to celebrate thirty years in business and was awarded the first-ever Award of Excellence by the Costume Council of the Los Angeles County Museum of Art. In 1997 and 1998 exhibitions of his work were featured at the Toledo Museum of Art,



the Philadelphia Museum of Art, and the Rhode Island School of Design Museum.

Beene's clothes have consistently been praised for their individuality and wearability. In a 1994 interview with Grace Mirabella he explained his philosophy of design:

The biggest change in fashion and the world has probably come in the past and present decade—the collapse of rules and their rigidity. This had to happen. There were too many illogical rules. I have never wished to impose or dictate with design. Its meaning for me is to affect people's lives with a certain joy, and not to impose questions of right and wrong. (Mirabella, p. 7)

Beene's lifetime achievement awards include the Smithsonian's Cooper-Hewitt National Design Museum's American Original award, presented in 2002. In 2003 he became the first recipient of the Gold Medal of Honor for Lifetime Achievement in Fashion from the National Arts Club. He received a career excellence award from the Rhode Island School of Design, which awarded him an honorary doctorate in 1992.

Beene weathered a famous seventeen-year feud with *Women's Wear Daily*, during which the publication refused to mention his name. By early 2002, Geoffrey Beene pulled his couture line out of retail stores; he continued to produce clothing for a select group of private clients.

See also **Fashion Designer; Paris Fashion; Vionnet, Madeleine; Women's Wear Daily.**

#### BIBLIOGRAPHY

- Anderson, Susan Heller. "Geoffrey Beene Takes On Europe." *New York Times*, 20 November 1977.
- Beene, Geoffrey. *Geoffrey Beene: The First Twenty-five Years: An Exhibition of the National Academy of Design, New York City, September 20 till October 9, 1988. Geoffrey Beene, Inc. Essay by Marylou Luther*. New York: National Academy of Design, 1988.
- . *Geoffrey Beene Unbound*. New York: Museum at the Fashion Institute of Technology, 1994. Interview by Grace Mirabella.
- Cocks, Jay. "Geoffrey Beene's Amazing Grace." *Time*, 10 October 1988.
- Cullerton, Brenda. *Geoffrey Beene*. New York: Harry N. Abrams, 1995.
- Dennis, Harry. "Geoffrey Beene," *TWA Ambassador*, September 1989.
- Fine Collins, Amy. "The Wearable Rightness of Beene." *Village Voice*, 10 January 1989.
- Fraser, Kennedy. *The Fashionable Mind: Reflections on Fashion, 1970–1981*. New York: Alfred A. Knopf, 1981.
- Martin, Richard. *American Ingenuity: Sportswear, 1930s–1970s*. New York: Metropolitan Museum of Art, 1998.
- Milbank, Caroline Rennolds. *Couture, The Great Designers*. New York: Stewart, Tabori, and Chang, 1985.

Morris, Bernadine. "In New Retail Shop, Beene Envisions a Laboratory of Fashion." *New York Times*, 19 December 1989.

Schiro, Anne-Marie. "Geoffrey Beene Shows the Way." *New York Times*, 2 November 1996.

Melinda Watt

**BELGIAN FASHION** In October 2003, the American newspaper *Women's Wear Daily* asked, "Is Belgian Avant-Garde Out of Fashion?" Twenty years after Belgian fashion design, with Antwerp as its epicenter, had won its place on the world scene, it was time to ask how things now stood with the avant-garde character of the Belgians. The Belgian designers, who had instigated a small revolution in the early 1980s with their unexpected images and conceptual approaches, were by 2003 counted by critics among the classic designers in their field. During the intervening two decades, the perception of Belgian fashion evolved from avant-garde, edgy, and against-the-grain toward a generally accepted classic style. "Antwerp" and "Belgian" became prefixes laden with high symbolic—and in some cases financial—capital and had successfully earned themselves a secure place alongside "French," "Italian," "Japanese," and "American."

Writing about Belgian fashion in terms of nationality is, however, not without its problems. Where the first-generation designers were still quite literally "Belgian," younger generations have taken on an increasingly international character; consequently the word does not refer to nationality in the strict sense, but rather to a certain identity that manifests itself at different levels—varying from visual imagery and graphic design to training and corporate culture—and which is perceived as characteristically "Belgian."

#### Early History

Prior to the 1980s, there was in fact no Belgian fashion. One precursor of the 1980s generation, however, was Ann Salens, an Antwerp designer who for a short time in the 1960s generated international furor and is an important point of reference for Belgian designers. Her extravagant, brilliantly colored dresses and wigs in artificial silk, her flamboyant lifestyle, risqué fashion shows, and happenings at unusual locations earned her the title of "Belgian Fashion's Bird of Paradise."

During the first half of the twentieth century, fashion in Belgium had primarily reflected what was taking place on the Paris runways. Parisian chic also dominated the Belgian image of fashion. Until 1950, creativity was restricted to the realm of interpretation, which frequently amounted to all but literal copying of the creations from the great French houses, which were in fact geared to this form of commercial reproduction. Smaller and less resounding names outside France could select from among various formulas with associated price tags, be-

ginning with attending the presentation of the collection—where it was strictly forbidden to take notes—up to the purchase of the patterns and original fabrics. If desired, the purchased design could be further sold under the new name. Even after the 1950s, however, it remained commercially uninteresting to advertise Belgian origins. In the early 1980s, established Belgian brands, such as Olivier Strelli, Cortina, and Scapa of Scotland, were choosing more exotic names that sooner disguised rather than emphasized their Belgian roots.

### The Golden 1980s

At the beginning of the 1980s, the Belgian government launched a plan to give new incentives to the stagnating textiles industry. On 1 January 1981, the Instituut voor Textiel en Confectie van België (ITCB, Institute for Belgian Textiles and Fashion) was established to provide constructive guidance for the various economic, commercial, and creative initiatives of the government's *textiles plan*. On the one hand, the Belgian textiles and apparel industry could call on government support in order to modernize and introduce new technology. On the other hand, a wide-ranging commercial campaign was begun, under the motto, "Fashion: It's Belgian." Its purpose was to provide Belgian fashion with a new and convincing image. At the same time, there was growing awareness that such a campaign had to be supported by a creative substructure, in which young talent was given every possible opportunity. In 1982, this led to the establishment of the annual Golden Spindle competition, the first of which was won by Ann Demeulemeester. Other laureates of that first edition were Martin Margiela, Dries Van Noten, Walter Van Beirendonck, Marina Yee, Dirk Van Saene, and Dirk Bikkembergs. Along with the requisite attention from the press and an article in the *Fashion: It's Belgian* magazine, the laureates were given the opportunity to collaborate with manufacturers to produce their collections, resulting in the first important reciprocal overtures between Belgian manufacturers and the new avant-garde designers.

During the late 1970s and early 1980s, Paris reached an apex with spectacular shows by Jean-Paul Gaultier and Thierry Mugler, among others, and with creations by Comme des Garçons and Yohji Yamamoto, which were lauded as works of art. Italy also brought innovation, with Gianni Versace and Romeo Gigli. In both ladies' and men's apparel, Italy established itself as a trendsetter, and Italian men's collections presented a new, nonchalant man, designed by Romeo Gigli or Dolce & Gabbana. This passion for pushing fashion to its peak and the exuberance of these collections in turn stimulated academy graduates and young designers in Antwerp.

There was a growing sense that Belgians could also produce fashion, and do so without the show elements so dependent on extravagant budgets. *Les gens du Nord*, or "the folks from the North," presented an avant-garde reversal to fashion, or *l'Anvers de la mode*—as the journalist



**Designer Véronique Branquinho.** Branquinho was named designer of the year in 1998. Her creations presented a simple, unpretentious attitude that signified the young, fascinating, and pure woman. © CORBIS SYGMA. REPRODUCED BY PERMISSION.

Elisabeth Paillée aptly wrote in a wordplay on the French name for Antwerp. This was the backside, the recycled, throwaway fashion, an underground phenomenon, the underdog: not so extroverted as English fashion, not so sexy as Italian fashion, not so cerebral as Japanese fashion.

As the only member of this group to do so, Martin Margiela went to Paris to apprentice with Gaultier (1984–1987) and eventually established his own Maison Martin Margiela in 1988. Maison Margiela developed an impressive oeuvre comprising differing lines, with recurring focus on such themes as tailoring, haute couture, recycling, and deconstruction. Margiela's story is a tale about the system that underlies fashion, a journey to discover alternatives that remain economically alive and which, in the fashion world, give new substance to the supposedly unassailable notion of innovation.

The remaining six designers decided to pool their resources and in 1987, left together for London's *British Designer Show*, where they were quickly noticed by the



**Veronique Branquinho Autumn/Winter 2004–2005 collection.** In the mid-1990s, Branquinho introduced fashions that evoked an air of mystery. Her simple, yet refined collections are carried by her label *James*. VERONIQUE BRANQUINHO, AUTUMN/WINTER 2004–2005, PHOTO: ALEX SALINAS. REPRODUCED BY PERMISSION.

press, who referred to them as the “The Antwerp Six”—purportedly because the difficult Flemish names were such tongue-twisters. Success was not long to follow. After London, they stormed Paris. By the late 1980s and early 1990s, most had their own fashion lines and retail outlets, as well as a permanent place on the Parisian fashion week calendar, with growing numbers of international selling points as a result.

Presenting these designers as a group, as the “Antwerp Six” or the “Belgians,” indeed overlooks their individual styles and identities. Where content, form, and image are concerned, it can in fact be difficult to find something they share in common. Dries Van Noten is

known for the ethnic or historic tone of his designs, with an almost naïve and at the same time touching exoticism. His flower motifs and the strong silhouette structure of his fashion shows are a trademark. In Ann Demeulemeester, there is a super-cooled romanticism, with a color palette reduced to the bare essentials: black and white. For her, the study of form is crucial, resulting in a union of such contrasts as masculine toughness and feminine elegance. Walter Van Beirendonck holds to an extreme eccentricity, with sources of inspiration ranging from science fiction to performance, comic books, and politics. From 1992 through 1999, he designed his W&LT line, followed by the introduction of his “Aestheticterrorists.” Dirk Van Saene seems to harbor a love-hate relationship with couture. His image of women is fickle, even cynical, yet his apparel designs demonstrate great love and attention to craftsmanship. Finally, Dirk Bikkembergs initially created a sensation with heavy men’s shoes with laces pulled through the heel. This subsequently evolved into an image that is sporty and sexy, perhaps most akin to Italian fashion.

### What Is Belgian?

If Belgian fashion cannot be understood in terms of a single style and if nationality itself is not the determining factor, what do these different designers have in common that makes their work recognizably Belgian? It is not the intention here to formulate a definition as such, but rather to indicate a number of aspects that contribute to the specific identity of the Belgian designers. One important factor is undoubtedly their training at the Royal Academy in Antwerp, with “individuality” and “creativity” being the principle concepts. Personal growth and creative development of the student are fundamental at school, without this one loses sight of the link between professional life. The personal approach also extends to the various peripheral activities that come along with the presentation of a collection, ranging from exceptional attention to the graphic design for the invitations and catalogs and particular focus on the location and design of the fashion show to a warm welcome in the showroom. One need only think of the now historic presentations of Martin Margiela’s collections in an abandoned Metro station or Salvation Army depots, Dries Van Noten’s delight-to-behold, beautiful shows, or the art performance tone of the presentations by Bernhard Willhelm and Jurgi Persoons for illustrations of this approach.

Nonetheless, the collection and the love and passion for clothing always take first place. With the Belgians, there is no superstar allure, or coquetry, but a healthy mix of humility, sobriety, and daring, and this translates first and foremost in the apparel itself. There is no blinding haute couture for the Belgians, but there is attention to professional craftsmanship, the study of form and concept; no out-of-control profits in the wake of the luxury houses, but a self-sufficiently structured enterprise in which as many factors as possible are kept under the de-



signers' own control; no top models whose star status relegates the clothes to subservient status, but real girls with character.

### The Next Generation

The generation following the “Belgian Six” found themselves faced with a very difficult challenge: how to create a profile and where to position oneself in the presence of such a strong avant-garde. Several responded by choosing not to present collections of their own. Perhaps the first to prove that there really was life after the Six was Raf Simons, who set his aims high with collections that indeed generated long-term changes in men's fashion. With images based on youth culture, the influence his work has had on the fashion field must not be underestimated.

In 1997, Véronique Branquinho presented a new woman: dreamy, young, mysterious, fascinating, and pure. Branquinho appeared on the scene as a young businesswoman with talent, and has been a pleasure to watch as her collections have grown together with their maker. Her collections are unpretentious and refined. Her label, James, refers to class—class without the glamour.

The A. F. Vandevorst designer team of An Vandevorst and Filip Arickx drew considerable press attention with the presentation of their second collection, in which girls slumbered and awoke in hospital beds. When the girls woke, their clothes still had the same pleats they had had when they lay down. It was an endearing and human image.

Bernhard Willhelm did not hesitate to begin by infusing his collection with humor. It was intended to provoke thought and balanced at the edge of cynicism, using new shapes and colors, and not be categorized in any single style. After only a few seasons, Willhelm was designing for the Italian house, Capucci, in addition to producing his own line.

Among the youngest designers, Haider Ackermann, of Colombian-French origins, has attracted particular attention. In 2002, he showed his first women's collection on the Paris catwalk. In 2003, he designed a collection for the Italian leather designers, Ruffo Research. His experiments with leather were astonishing, combining superb knowledge of material and form, along with the necessary dose of elegance and craftsmanship.

Brussels, too, is making itself heard. The super-talented Olivier Theyskens, who was designing for Rochas, prematurely broke off his training at the La Cambre School for Fashion in Brussels and almost immediately became a center of attention when the pop icon Madonna appeared in one of his creations. Theyskens achieved wonders in linking Parisian elegance to a certain Belgian conceptuality and sobriety. His designs are exquisitely beautiful, approaching perfection, yet at the same time possessing a dark underside, a gothic edge.

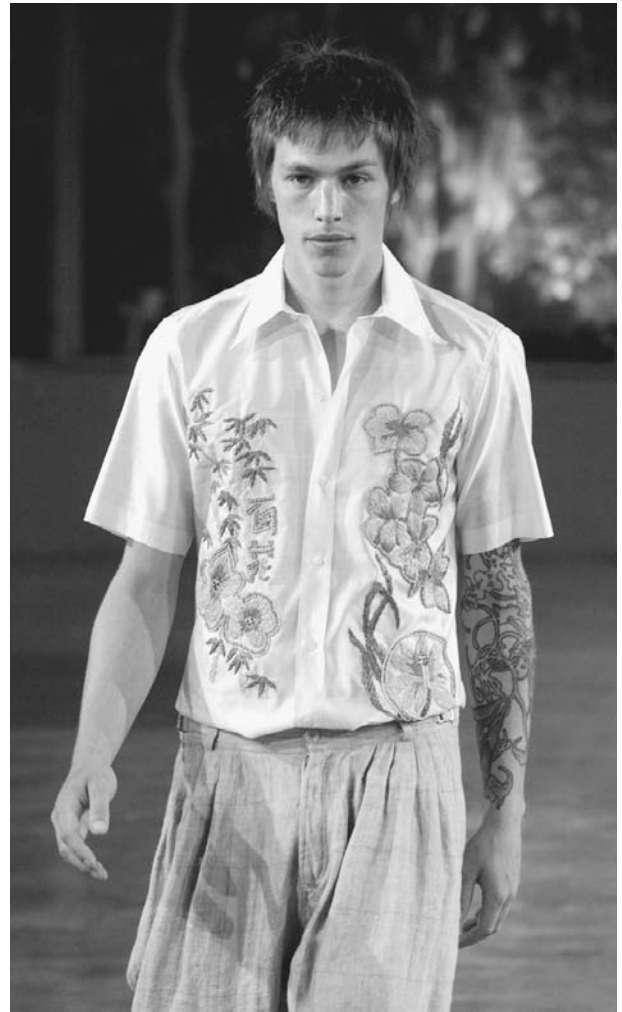

**Dries Van Noten Spring/Summer 2002 Men's Ready-to-Wear Collection.** Belgian fashion first arrived on the runway in the 1980s after the Belgian government gave incentives to revitalize the textile industry. Belgian designers created their own brand of individual, avant-garde apparel. © REUTERS NEWMEDIA. REPRODUCED BY PERMISSION.

### The Fashion Nation

With the achievements of the 1980s generation in mind, Antwerp became increasingly conscious of the fact that a number of structures had to be brought into play if the unique position that the city enjoyed in the fashion world were to be maintained. The starting bell rang in 2001, during Antwerp's “Year of Fashion,” with the hosting of a broad-ranged series of artistic events curated by Walter Van Beirendonck. At the same time, the “Fashion Nation” opened its doors in the heart of Antwerp. By way of three different organizations, the Fashion Nation unites three influences on fashion: education, culture, and economics. The fashion department of the Royal Academy is located on the top floor and also symbolically stands for “top floor” and creative input. The next story

down is home to the MoMu Museum of Fashion and the Flanders Fashion Institute (FFI). The MoMu unites heritage and tradition with an innovative approach, while the FFI has the task of bridging a link with the financial world, by way of a production fund for starting designers and countless other activities to help Belgian designers achieve the aura they need at both national and international levels.

*See also Italian Fashion; Japanese Fashion; London Fashion; Margiela, Martin; Paris Fashion.*

#### BIBLIOGRAPHY

- Coppens, Marguerite, ed. *Les Années 80: L'Essor d'une mode Belge* [The 1980s: The Rise of a Belgian Fashion]. Brussels, Belgium: Musées Royaux d'Art et Histoire, 1995.
- Debo, Kaat, ed. *The Fashion Museum Backstage*. Ghent, Belgium, and Amsterdam: Ludion, 2002.
- Derycke, Luc, and Sandra Van De Veire, eds. *Belgian Fashion Design*. Ghent, Belgium, and Amsterdam: Ludion, 1999.
- Esch, Gerdi, and Agnes Goyvaerts. *Mode in de Lage Landen: België* [Fashion in the Low Countries: Belgium]. Antwerp, Belgium: Hadewijch, 1989.
- Weekend Knack 20 Years Fashion It's Belgian*. Issue 37. Roese-laere: Roularta Media Group, 2003. Jubilee issue with an excellent overview of who's who in Belgian fashion.
- Windels, Veerle. *Jonge Belgische Mode* [Young Belgian Fashion]. Ghent, Belgium, and Amsterdam: Ludion, 2001.

*Kaat Debo and Linda Loppa*

**BELTS AND BUCKLES** A belt is any length of material that encircles and is secured around the waist. Popular materials include leather, fabric, and metal. Belts are worn by males and females to define the fashionable waist and for a variety of other functions in many world cultures.

Sometimes referred to as a girdle or sash, the belt was worn in the Bronze Age and in ancient Crete, Greece, and Rome and is mentioned in the Bible.

Belts accent the fashionable position of the waist as it travels from under the breast to its natural position to low on the hips. As shirtwaist and skirt ensembles became a popular option for women in the nineteenth century, they were often accessorized with contrasting belts. In the 1860s, the Swiss belt, a wide, back-laced, and usually black belt, defined a woman's waist. Belts held special importance again when the New Look dictated small waists for post-World War II women.

During the twentieth century, women's belts were often of the same fabric as their matching dress or coat. Belts of metal or plastic links have also been worn as trendy fashion accessories by women. Twentieth-century men almost exclusively wore leather belts to secure their trousers. Belts of webbing borrowed from military uniforms were another, more casual, option for males.

Functionally, belts relieve the wearer's shoulders of part of the weight of the garment. Another function of belts is for attaching items; during the Middle Ages and Renaissance, women hung chatelaines, cosmetics, mirrors, pomanders, and purses from their belts. Police officers in America continue to use belts to hold items such as their guns, clubs, and pepper spray, and carpenters and other tradesmen carry their tools in utility belts. In the twentieth century, garter belts, an undergarment, were used by women and children to hold up stockings before panty hose and tights became common.

Belts denote rank in the martial arts. Actually it is the color of the belt that denotes rank. Originally, there were three belt levels: white belt, brown belt, and black belt, with black belt as the highest rank. A common myth explaining this system states that all students started by wearing white belts and through use the white belts turned brown and then black over time. More likely the colored belt system was borrowed from the one used in Japanese school athletics, particularly in ranking swimmers. In the 1960s the white belt rank was divided into several different colored belt levels: yellow, orange, purple, blue, and green, as a way of showing progress toward the higher ranks. The ranking of the colors varies among each style of martial arts. Adding stripes to belts is another way of showing progress at the lower levels.

Belts can also reveal identity. In the military, opposing armies or regiments were identified by the color sash they wore (in the Thirty Years War), as well as different branches of the service (in the American Civil War for example, general officers: buff; cavalry officers: yellow; and medical officers: emerald). During the Middle Ages in some cities, belts were worn as a sign of respectability and position and women of questionable repute were prohibited from wearing them.

Infamous or mythical, chastity belts have endured in the popular imagination. Purportedly invented to ensure women's fidelity while their husbands were away during the Crusades, a woman locked into a chastity belt was effectively prevented from having sexual intercourse. Modern versions of the chastity belt are included in fetish gear.

Belts are also used to provide protection. Weight-lifting belts provide stability to the spine and lower back thus reducing risk of injury to the lifter. Delivery people and others who do lifting in their occupations wear similar belts. Seat belts are often complained about for being uncomfortable or for crushing the wearer's clothing. Several decades after automobiles became common, a movement started to promote motor vehicle seat belts. In the 1960s seat belts became standard in new vehicles, and in the 1980s, many countries began passing laws that mandated seat belt use for drivers and passengers.

Another twentieth-century device is the sanitary belt. Similar to a garter belt, a sanitary belt secured a woman's menstrual pad. These belts were popular and available into the 1970s.

Some belts act as currency. Natives of the Solomon Islands used belts of shell money. American Indians used wampum, belts of shell beads, as well.

### Buckles

Buckles are a common way to fasten belts. Often a metal-frame buckle may catch in holes punched into the belt. Sometimes the end of a belt is woven through the buckle to fasten it. And other belt buckles hook to fasten the belt.

Buckles can be very decorative—covered with fabric, studded with rhinestones, or elaborately carved or molded. In the early twentieth century, buckles of bone and shell were popular for females. Perhaps the most elaborate in design and size are western belt buckles. Ornate western buckles first appeared in the 1920s due to the popular western heroes in Hollywood films. Since then western buckles are sometimes given as trophies in rodeo competitions.

From the American cowboy's buckle to the Japanese woman's complex obi, belts and buckles are culturally and historically significant elements of fashion.

See also **Girdle; Hats, Women's; Leather and Suede; Veils.**

### BIBLIOGRAPHY

- Besancenot, Jean. *Costumes of Morocco*. London and New York: Kegan Paul International, 1990.
- George-Warren, Holly, and Michelle, Freedman. *How the West Was Won*. New York: Harry N. Abrams, 2001.
- Haines, Bruce A. *Karate's History and Traditions*. Rutland, Vt.: C.E. Tuttle, 1968.
- Kybalova, Ludmila, Olga Herbenova, and Milena Lamarova. *The Pictorial Encyclopedia of Fashion*. Translated by Claudia Rosoux. New York: Crown Publishers, 1968.
- Milbank, Caroline Rennolds. *The Couture Accessory*. New York: Harry N. Abrams, 2002.
- Newman, Cathy. *Fashion*. New York: National Geographic, 2001.
- Shep, R. L., W. S. Salisbury, and P. Dervis. *Civil War Gentlemen: 1860's Apparel Arts and Uniforms*. Mendocino, Calif.: R. L. Shep, 1994.

Mark Schultz

**BENJAMIN, WALTER** The German writer and cultural critic Walter Benjamin (1892–1940) was born in Berlin, one of three children of assimilated Jewish parents. In 1912 he began his studies in philosophy, German literature, and art history at the University of Freiburg and then moved back to Berlin, where he encountered the teachings of the philosopher Georg Simmel. In 1914 he continued his studies at the universities in Munich and Bern, Switzerland. Benjamin married Dora Kellner in 1917; they had one son, Stefan, in 1918, before the marriage ended in divorce in 1930. Benjamin's doctoral dis-

sertation on German Romanticism was accepted by the University of Bern in 1919. In 1923 he met his closest intellectual friends, the philosopher Theodor Wiesengrund Adorno and the cultural historian Siegfried Kracauer. His attempts to submit another professional dissertation to the University of Frankfurt, on the origin of German tragic drama, were not successful. The work was published in 1928 under the title *Ursprung des deutschen Trauerspiels* (*The Origin of the German Tragic Drama*).

Benjamin eked out a precarious existence as writer, translator, and journalist. In 1925–1927 he journeyed to Moscow, to visit Asja Lascis, whom he had fallen in love with. In 1933, in the wake of the rise of Hitler and Nazism, he left Germany for Paris, where he stayed except for brief visits to the German dramatist Bertolt Brecht in Denmark. Before his exile to France, Benjamin had begun to formulate *Das Passagenwerk* (*The Arcades Project*), his work on Paris in the nineteenth century; he would devote the remainder of his life to this incomplete magnum opus.

In 1936 he wrote the famous essay “Das Kunstwerk im Zeitalter seiner technischen Reproduzierbarkeit” (“The Work of Art in the Age of Mechanical Reproduction”). The text is the first to postulate the loss of the work's aura, that is the demise of its multi-tiered authenticity in view of the cultural implications of art's reproducibility in modern media. The German occupation of Paris in 1939 drove Benjamin from the French capital, but his manuscripts remained hidden in the vaults of the Bibliothèque Nationale until after the war. Border police halted his attempt to escape to Spain across the Pyrenees in September of 1940. Mentally and physically exhausted, Benjamin committed suicide in Port Bou, Spain. He carried with him a black bag with what is rumored to have been a final version of *The Arcades Project*. It was never recovered.

### Benjamin on Fashion

Benjamin's significance for the interpretation of fashion resides in his unfinished chef-d'œuvre, *Das Passagenwerk*. A vast array of fragments, excerpts, aphorisms, quotations, metaphysical musings, and sociopolitical observations constitute the material for this book on Paris in the nineteenth century, the “pre-history of modernity,” as Adorno called it. Fashion, both as an economic force and a visual signifier, is one of the most important features of *The Arcades Project*. Benjamin collected some hundred entries that deal with couture, dress codes and the art, literature, philosophy, and sociology of clothing (including a wealth of quotations from Simmel). His works on French literature; translations of Charles Baudelaire and Marcel Proust, with whom he shared sensibilities in regard to fashion; and essays on visual art in France were preparatory to the project, and his collections *Thesen über den Begriff der Geschichte* (1942; *Theses on the Philosophy of History*) and *Zentralpark* (1955; *Central Park*) are methodological spin-offs. A number of abstracts that he produced



over the course of a decade explain and modify his conceptual approach.

Common to all these writings is the centrality of fashion as a historical fact—not simply as a historicized element of the past but more as a force that through its constant self-reference and quotation breaks the historical continuum and activates, at times even revolutionizes, past occurrences for the present. It is Benjamin's principal achievement to use dialectical materialism—that is, the materialist philosophy that regards the process of development in thought, nature, and history as coined by the necessary contradiction of ideas (albeit rather unorthodoxically) in this context as a structuring device against historicism, which uses styles, ornamentation, and motifs from the past often in eclectic and not reflective combination, and also against the notion of history marked by linear progress toward constantly higher levels of technical proficiency and material satisfaction. The potency of Georg Friedrich Wilhelm Hegel's and Karl Marx's concept of history as turning from quantitative progression to qualitative change is used by Benjamin to create an analogy in fashion's willful quotations from its own source book, where a particular style or stylistic element is taken from costume history and brought into present fashion to create reference and friction simultaneously, along with new commodities. This method is seen as particular to fashion, not just as the result of the seasonal structure of haute couture but because fashion operates differently from the historicism inherent in other decorative or applied arts. Thus, for example, quotations in Empire furniture are different from citations of Greek dress in the Directoire fashion. Through the stylistic quote, the console or chair merely offers a consolidation of historical substance, while the high-waisted dress presents the direct impression of the democratic ideal on the body politic.

In his *Theses on the Philosophy of History* Benjamin finds a poetic definition of fashion in history, a definition that moves from metaphysical to material questions and perceives fashion as a structural device. Through the sartorial quotation, fashion fuses the thesis of the eternal or "classical" ideal with its antithesis, which is the openly contemporary. The apparent opposition between the eternal and the ephemeral is rendered obsolete by the leap that needs the past for any continuation of the present. Correspondingly, the transhistorical describes the position of fashion as detached both from the eternal, that is, an aesthetic ideal, and the continuous progression of history. Benjamin conjures up the image of the "*Tigersprung*" to explain how fashion is able to leap from the contemporary to the ancient and back again without coming to rest exclusively in one temporal or aesthetic configuration. This generates a novel view of historical development. Coupled with the dialectical image, the tiger's leap under the open skies of history marks a convergence that is revolutionary in its essence.

The text that contains the *Tigersprung* thesis indicates what *The Arcades Project* could have constituted in terms of a radical rethinking of fashion in modern culture, if Benjamin had finished it. Its excerpts demonstrate the leap from a sociological, art historical, or material observation of clothes to an understanding of fashion's unique character as a historical constituent, a structuring device, potentially even a revolutionary force. Benjamin tempts us in his unfinished work with glimpses of a new abstract perception of fashion viewed independently of its material basis (textile industry, haute couture, distribution, representation, and so forth), but retaining its materialism, that is, its sociopolitical significance. It is seen as part of intellectual culture, to be debated and interpreted simultaneously as sensuous and poetic, that is, as an expression of contemporary beauty, and on an abstract and metaphysical level, as an independent structure of modern existence and cognition.

See also **Fashion, Historical Studies of; Fashion, Theories of; Historicism and Historical Revival; Simmel, Georg.**

#### BIBLIOGRAPHY

##### *Works by Walter Benjamin*

"Theses on the Philosophy of History." *Illuminations*. London: Cape, 1970: 263.

*The Correspondence of Walter Benjamin 1910–1940*. Edited by Gershom Scholem and Theodor W. Adorno. Translated by Manfred R. Jacobson and Evelyn M. Jacobson. Chicago: University of Chicago Press, 1994.

*The Arcades Project*. Translated by Howard Eiland and Kevin McLaughlin. Cambridge, Mass.: Belknap Press, 1999.

*Selected Writings of Walter Benjamin*. 4 vols. Cambridge, Mass.: Belknap Press, 1996–2003.

##### *Works about Walter Benjamin*

Bolz, Norbert W., and Richard Faber, eds. *Antike und Moderne: Zu Walter Benjamins "Passagen."* Würzburg, Germany: Königshausen and Neumann, 1986.

Buck-Morss, Susan. *The Dialectics of Seeing: Walter Benjamin and the Arcades Project*. Cambridge, Mass.: MIT Press, 1989.

Bulhaupt, Peter, ed. *Materialien zu Benjamins Thesen "Über den Begriff der Geschichte": Text, Varianten, Briefstellen, Interpretationen*. Frankfurt, Germany: Suhrkamp, 1975.

Frisby, David. *Fragments of Modernity: Theories of Modernity in the Work of Simmel, Kracauer, and Benjamin*. Cambridge, U.K.: Polity, 1985.

Lehmann, Ulrich. *Tigersprung: Fashion in Modernity*. Cambridge, Mass.: MIT Press, 2000.

Smith, Gary, ed. *On Walter Benjamin: Critical Essays and Recollections*. Cambridge, Mass.: MIT Press, 1988.

———. *Benjamin: Philosophy, Aesthetics, History*. Chicago: University of Chicago Press, 1990.

Steinberg, Michael P. *Walter Benjamin and the Demands of History*. Ithaca, N.Y.: Cornell University Press, 1996.

Vinken, Barbara. "Eternity—A Frill on the Dress." *Fashion Theory* 1, no. 1 (1997): 59–67.

Wismann, Heinz, ed. *Walter Benjamin et Paris: Colloque international 27–29 Jun 1983*. Paris: Le Cerf, 1986.

Wolin, Richard. *Walter Benjamin: An Aesthetic of Redemption*. Berkeley: University of California Press, 1994.

*Ulrich Lehmann*

**BERET** A beret is a round, flat, visorless cap worn by both sexes over centuries. Berets are made from circular pieces of knitted, woven, or felted cloth, occasionally velvet, and drawn underneath by a string, thread band, or leather thong so as to fit around the head. They may be decorated with objects, such as ribbons, plumes, pins, tassels, jewelry, precious stones, fabrics, and cords.

Options for wearing the beret include set back on the head (halo style), flat on the head (pancake style), pulled down covering the ears (winter version), dipping diagonally to one side (fashion style), or pulling over the eyes for sleeping (oversized practical type).

Archaeological and art historical evidence indicates that variations of the beret have been worn by Bronze Age inhabitants of northern Europe, Ancient Cretans, Etruscans, English aristocrats such as Henry VIII, along with baroque and modern artists (Rembrandt to Picasso).

### Basque Beret

The modern “Basque” beret originated with shepherds living on both sides of the Pyrenees in southern France and northern Spain. Little is known of Basque peoples’ origins, and in the Spanish Provincias Vascongadas, different color berets were worn: red in Guipúzcoa, white in Álava, blue in Vizcaya. Eventually, the Basques all adopted blue, while red berets were taken over as part of the provincial folk costume in neighboring Navarre. The wearing of black berets spread to villages throughout Spain, and by the 1920s they were associated with working classes in France.

### Production

Basque beret production dates back to the seventeenth century in the non-Basque area of Oloron-Sainte-Marie, a small town in southern France, where sheep grazed on nearby mountainsides. Locals, like many other peoples, discovered that when wetted and rubbed together, small bits of wool became felted. While still moist, the felt could be hand manipulated by pulling it over the knee, thereby creating a rounded shape appropriate for covering the head.

Originally made by hand for male villagers, beret making became industrialized in the nineteenth century, with the first factory, Beatex-Laulhere, claiming production records dating back to 1810. Other factories followed and, by 1928, over twenty were producing millions of berets for international markets, stimulated by World



**Polish Girl Scouts wear white berets as part of their uniform.**

Variations of the beret have been a popular head dress for centuries in Europe and other parts of the world. © PETER TURNLEY/CORBIS. REPRODUCED BY PERMISSION.

War I military and civilian migrations. French sheep wool was originally used; later merino was imported from Australia and South Africa. By the mid-twentieth century, softer berets made of angora (molted rabbit fur) mixed with thermofibers attracted female wearers.

Basque berets are usually made during winter months and involve ten steps: knitting, sewing, felting, blocking, drying, checking, brushing, shaving, “confection” or finishing, and delivery. In 1996, a beret museum opened in the village of Nay, sponsored by the manufacturer Blancq-Olibet, which provides public educational tours on Basque beret manufacture.

### Beret Usage

Over time, berets have been worn for political, military, religious, and aesthetic reasons. Symbolic meanings developed that were associated with color. The black beret became so popular with French urban workers that beret-wearing resistance movement fighters (Maquis) during World War II were able to blend into crowds without raising suspicion among German occupation forces. The dark beret became the trademark of Che Guevara, leader in the 1959 Cuban Revolution, and many of his later followers. A Che beret is preserved at the Museum of the Revolution in Havana.



**A worker spins a Beighau beret.** Originally, berets were made for male villagers from wet wool that was hand-shaped by pulling it over the knee creating a rounded shape that fit over the head. © PAVLOVSKY JACQUES/CORBIS SYGMA. REPRODUCED BY PERMISSION.

Because of its flexibility, the beret was ideal for low-ranking military uniforms. Originally worn by nineteenth-century French seamen, it was adopted during World War I for alpine troops. British Field Marshal Montgomery popularized the beret during World War II as a badge of honor for elite military units. Since the Korean Conflict, berets have identified Special Forces as the “Green Berets,” paratroopers trained to drop behind enemy lines (maroon beret) and the U.S. Army Rangers (whose beret was changed from black to tan). During the 1960s Vietnam War, “The Ballad of the Green Berets” brought to public attention the exploits and heritage of these courageous units, symbolized through their caps and shoulder badges.

A controversy broke out in 2000 C.E. when black berets became standard issue to all incoming U.S. Army recruits in an effort to attract and boost morale for an all-volunteer army. Some traditionalists felt the beret as an elite symbol had become compromised. Additionally,

to meet the several million beret orders, manufacturers overseas were contracted, which required waiving a U.S. law requiring all clothing and textiles purchased by the military to be produced in the United States.

Over the past half century, United Nations troops have been identified by their baby-blue berets, and peace-keeping forces by orange ones. The beret is worn by modern armies worldwide, including Russia, Iraq, Pakistan, Venezuela, Democratic Republic of the Congo, and South Africa.

In an effort to combat urban crime during the 1990s, volunteer units known as Guardian Angels or “Red Berets” began patrolling city streets in the United States and Europe, later in urban centers in Africa, South America, and Japan. Their bright red berets serve as warnings to petty criminals and reassurance to community residents.

Jamaican Rastafari, and later followers in Central America and the United States, motivated by Black Religious Nationalism, follow biblical prescription by wearing long-uncut, uncombed, and matted hair (dreadlocks) covered by a knitted or crocheted black beret with red, gold, and green circles. Rastafari consider the beret and dreadlocks as an individual’s crown, symbols of power representing the Biblical Covenant of God with His Chosen People, Black Israelites (Genesis 9:13).

As a Western fashion statement, the beret has been worn as “classic” sportswear by adults of both sexes and children since the 1920s and is especially popular during wartime and the winter olympics. As part of the U.S. Girl Scouts’ required uniform, the beret was adopted in 1936 and only replaced in 1994 by the universally popular visor baseball cap.

Variations of the beret include the Scotch Bonnet, a flat, woven or knitted woolen cap with ribbon cockade and feathers that serve to identify the wearer’s clan and rank. Worn at an angle and usually dark blue, called “Bluebonnet” for Scotland’s national color, it has been a symbol of Scottish patriotism. The entire Highlander costume including the Bluebonnet was outlawed for many years by the British government. After construction of Balmoral Castle at Aberdeenshire, Scotland, in 1855, the Bonnet came to be called the “Balmoral” because of recognition given the Highlanders by Queen Victoria and Prince Albert.

Other Scottish types include the tam-o’-shanter, made of brushed wool with a large pompom in the center and named after a Robert Burns poem, and the striped woolen Kilmarnock Cap, also with pompom, named for a town in Strathclyde.

*See also* **Afrocentric Fashion; Felt; Hats, Men’s; Hats, Women’s; Military Style.**

#### BIBLIOGRAPHY

Denford, Carole. “Le Vrai Basque.” *The Hat Magazine* (April/May/June 2001): 34–37.



Wilcox, R. Turner. *The Mode in Hats and Headdress*. New York and London: Charles Scribner's Sons, 1945.

Beverly Chico

**BERTIN, ROSE** Rose Bertin was born Marie-Jeanne Bertin (1747–1813) in Abbeville, a textile town in the Picardy region of France. Her family was not wealthy, and so she was apprenticed to a *marchande de modes* (fashion merchant) at a young age. By 1772 she had worked her way up to the exclusive rue Saint-Honoré in Paris, where she opened her own shop under the name of the *Grand Mogol*. She quickly won the patronage of several influential courtiers, including the duchess of Chartres, Louise Marie Adélaïde de Bourbon, who introduced Bertin to the newly crowned queen, Marie Antoinette, in the summer of 1774.

The queen of France quickly became Bertin's most famous customer. Sources of the day (including Bertin's surviving business records) document more than 1,500 clients; undoubtedly, there were many more of whom no credible record survives. In addition to Marie Antoinette, Bertin dressed the queens of Spain, Sweden, and Portugal; Grand-Duchess Maria-Fëdorovna of Russia; and many European aristocrats. The latter group included Marie Jeanne Bécu, the comtesse Du Barry; the duchess of Devonshire; Georgina Cavendish and the cross-dressing Charles Geneviève Louis D'Eon de Beaumont, Chevalier d'Eon. Bertin also dressed celebrities like the Vestris family of dancers and the actress Mademoiselle de Sainval of the Comédie-Française, who were fashion plates both onstage and off. Indeed, Bertin was the first "fashion designer" to become a celebrity in her own right.

In the twenty-first century, it is taken for granted that fashion designers can achieve international fame. But the ancien régime offered few avenues for social mobility, particularly for unmarried women of humble birth. Bertin overcame these obstacles with equal measures of talent and ambition, manipulating the young queen and the emerging fashion press to make her name and her creations known throughout the world.

### Minister of Fashion

Marie Antoinette is remembered as a woman preoccupied with fashion. In fact, before she met Bertin, she was not considered particularly well dressed. Bertin was not Marie Antoinette's only *marchande de modes*; the task of clothing the queen was far too demanding for just one person, and Bertin had hundreds of other clients to accommodate. But no other *marchande de modes* enjoyed such easy access to the queen or to the royal purse. Thus, Rose Bertin and Marie Antoinette were inextricably linked in the public imagination.

When the *marchandes de modes* of Paris were incorporated in 1776, Bertin was elected as the guild's first

mistress. In this post, she earned the right to dress the life-sized fashion doll that toured the mercantile centers of Europe and beyond, advertising French fashions. In 1777 Bertin had a staff of forty employees, not including dozens of subcontractors and suppliers. By 1778 Bertin had grown so powerful at court that the press dubbed her France's *ministre des modes*, or "minister of fashion." The unofficial title underlined Bertin's position as a trusted royal adviser as well as a representative of France to other nations.

Bertin's partnership with the queen ensured her success, but it would also prove to be her undoing. As Marie Antoinette's popularity waxed and waned, so did that of her favorite minister. Courtiers were outraged by Bertin's privileged place in the royal circle, unprecedented for a commoner. Furthermore, her success at court gave her an ego of princely proportions. Soon Bertin was as famous for her arrogance and astronomical prices as she was for her fashions and celebrity clients. Previously, labor had represented only a fraction of the cost of a garment. By demanding star status and a star's salary, Bertin helped elevate fashion from a trade to an art.

### French Revolution

The outbreak of the French Revolution forced hundreds of fashion workers out of business or out of the country. Some left voluntarily, following their aristocratic clients; others feared that they would be persecuted if they remained in France. With her ties to queen and court, Bertin had every reason to fear for her life as well as her livelihood. While the aristocracy saw Bertin as an upstart and an interloper, to the revolutionaries she was no better than an aristocrat herself. Royalists and Republicans alike blamed Bertin for encouraging Marie Antoinette's excesses, which she continued to do right up until the queen's imprisonment.

Bertin fled Paris in 1792 and spent the next three years in such émigré havens as Brussels, Frankfurt, and London, where she continued to dress fashionable foreigners and French exiles. Unlike her royal muse, Bertin managed to survive the French Revolution unscathed. Although she was twice put on the government's émigré list, she managed to prove that she had left France on legitimate business both times. The émigré list was the official record of people who had emigrated, thus forfeiting their property and, in some cases, their lives. Effectively, Bertin was declared a fugitive.

By the time Bertin returned to Paris, she was out of danger but also out of fashion. Bertin could still count a few English, Russian, and Spanish aristocrats among her clients, but hardly any Frenchwomen. Indeed, many of her French clients had perished on the scaffold, leaving their bills unpaid. The Revolution cut Bertin's career short at the height of her power, and she never recovered financially or emotionally. She died at her country retreat in Épinay-sur-Seine just a few months too soon

to see restoration of the monarchy in 1814. Even after her death Bertin remained a potent and provocative symbol of the elegance and excess of the ancien régime.

See also **Court Dress; Fashion Designer.**

#### BIBLIOGRAPHY

- Chrisman, Kimberly. "Rose Bertin in London?" *Costume* 32 (1999): 45–51.
- Langlade, Émile. *La marchande de modes de Marie-Antoinette: Rose Bertin*. Paris: Albin Michel, 1911. Entertaining but unreliable biography.
- . *Rose Bertin: The Creator of Fashion at the Court of Marie-Antoinette*. Translated by Dr. Angelo S. Rappoport. New York: Charles Scribner's Sons, 1913. An English-language biography adapted from the French version.
- Nouvion, Pierre de, and Émile Liez. *Un Ministre des modes sous Louis XVI: Mademoiselle Bertin, marchande de modes de la reine, 1747–1813*. Paris: Henri Leclerc, 1911. Contains detailed information about Bertin's family history.
- Sapori, Michelle. *Rose Bertin: Ministre des modes de Marie-Antoinette*. Paris: Regard/Institut Français de la Mode, 2004. Illustrated monograph incorporating recent research on Bertin's career, competitors, and clients.

Kimberly Chrisman-Campbell

**BEST-DRESSED LISTS** Since their inception in the first half of the twentieth century, best-dressed lists have become a popular barometer of international style. By publishing best-dressed lists in the mainstream media, fashion editors and style arbiters have established a steady market for information about the wardrobes, grooming, and comportment of smartly dressed men and women.

Perhaps the most eminent best-dressed list was the "International Best-Dressed Poll," the brainchild of Eleanor Lambert (1903–2003), a New York City publicist considered the doyenne of fashion publicity. Lambert first penned the list in 1940 as a press release for the New York Dress Institute, a trade organization she helped establish to stimulate dress sales during World War II. Lambert claimed that her list was patterned after an anonymous poll of the world's ten best-dressed women issued by the Paris couture starting in the 1920s.

Lambert's annual list became a widely heralded tally of the world's most beautifully dressed people, derided as frivolous, yet eagerly anticipated. She coordinated the poll by canvassing a coterie of fashion insiders to nominate the contenders, and then revealed the winners in a press release to the media. Lambert elevated repeat winners to her own fashion Hall of Fame. Finally, at nearly 100 years old, she stopped coordinating her celebrated list in 2002.

Another important best-dressed list has been the domain of Richard Blackwell. In 1958, Blackwell established



#### PERENNIAL BEST-DRESSED

Marella and Gianni Agnelli  
 Fred Astaire  
 Marisa Berenson  
 Tina Chow  
 Cary Grant  
 C. Z. Guest  
 Gloria Guinness  
 Audrey Hepburn  
 Slim Keith  
 Jackie Kennedy  
 Babe Paley  
 Millicent Rogers  
 John Hay "Jock" Whitney  
 The Duke and Duchess of Windsor

a line of evening gowns under the label "Mr. Blackwell," which attracted high-profile buyers like Nancy Reagan and Zsa Zsa Gabor. In 1960, *American Weekly* magazine, a national Sunday newspaper supplement, hired him to compile a list of Hollywood's best- and worst-dressed stars. Mr. Blackwell's list became notorious for his willingness to criticize icons like Brigitte Bardot and Queen Elizabeth II. The lists established Blackwell as a popular arbiter of taste, and he continues to issue his controversial fashion pronouncements as of the early 2000s.

Given the visibility of Lambert's and Blackwell's lists, fashion editors were inspired to publish best-dressed lists of their own. Among the publications that have published, or continue to publish, best-dressed lists are *Vogue*, *Harper's Bazaar*, *Vanity Fair*, and *Prima*. *People* magazine publishes an annual special issue featuring best- and worst-dressed celebrities, while the annual Academy Awards show has spawned its own best-dressed subcategory. Other best-dressed lists have been printed by non-fashion publications like *Fortune* magazine and the *New York Post*.

Best-dressed lists allow readers to imagine that a winning profile is open to all, when in fact the top spots invariably go to wealthy people in the public eye: film stars and fashion industry or society figures. But the lists continue to fascinate as they impart lessons in style, self-presentation, and the ineffable quality of individual chic.

See also **Fashion.**

#### BIBLIOGRAPHY

- Blackwell, Richard. *Mr. Blackwell's Worst: 30 Years of Fashion Fiascos*. New York: Pharos Books, 1991.

Haugland, H. Kristina, and Dilys E. Blum. *Best Dressed: Fashion from the Birth of Couture to Today*. Philadelphia: Philadelphia Museum of Art, 1997.

Nemy, Enid. "Eleanor Lambert, Empress of Fashion, Dies at 100." *The New York Times*, 8 October 2003.

Wilson, Eric. "Eleanor Lambert Celebrates an American Fashion Century." *WWD* 186, no. 26 (6 August 2003).

*Kathleen Paton*

**BIBA** Biba has become a potent legend quite out of proportion with its relatively brief life in the mid-twentieth century. It was a shop and a label—but it was more than either or both of these: it came to stand for the “swinging chick,” the ideal, running, jumping and never-standing-still girl, the image that dominated fashion from the mid-1960s until about 1974. That one word, “Biba” calls up from memory the long-legged, zany, crop-haired Twiggy morphing into the druggy, Pre-Raphaelite hippie of 1970: from the futuristic to the retro in four short years.

Biba was the creation of Barbara Hulanicki and her husband, Stephen Fitz-Simon. It began as a mail-order firm, selling gamine gingham shifts with matching head scarf in the wake of Brigitte Bardot. In 1964 the couple followed the just emerging trend for the fashion boutique as opposed to the department store where most women bought their clothes in the 1950s. (Small dress shops, known in Britain as “madam shops,” still existed, but were by this time considered very old-fashioned, and small dressmakers were also dying out.) Biba’s first outlet opened in the smart Kensington district of London. The young couple rented what had been a chemist’s shop, retained in the window the big period bottles of ruby- and topaz-colored liquids that traditionally decorated such shops at that time (suggestive of magical potions), and created a dark blue interior with William Morris curtains, more like an Aladdin’s cave than an ordinary shop. This was a totally different shopping experience from the department store or the “madam shop.” There were no assistants pressuring you to buy by peering into the claustrophobic changing room and commenting on the clothes; instead there was a communal changing room free for all, more reminiscent of the school locker room than of adult life—but in an exciting way. The message was always that these fashions were for the young and carefree.

Biba really began to make an impact just as the mood of the 1960s began to change. From 1966 on, a creeping sense of economic discontent and social unrest in Britain was beginning to supersede the optimism of the first half of the decade. One of the ways in which this was expressed stylistically was in the mutation from future to past. By 1967 the Courrèges look—flat white boots and a square-cut tunic, reminiscent of cinematic fashions of the future—was being displaced by much dreamier



**Biba.** From the mid-1960s until about 1974, Barbara Hulanicki and her husband, Stephen Fitz-Simon, capitalized on an emerging “old is new again” fashion trend with their London Biba boutique. The shop was furnished with Old World furniture and lamps while the clothing was reminiscent of the styles of the 1920s and 1930s. LARRY ELLIS/EXPRESS/GETTY IMAGES. REPRODUCED BY PERMISSION.

clothes. The two other most influential British fashion designers of the period, Mary Quant and Ozzie Clark, began to use such “old-fashioned” textiles as crêpe and satin in art deco colors of eau de nil, cream, rust, and even maroon. Biba was at the epicenter of this trend from the beginning. The shops had a distinctly period feel, with bentwood furniture, vases of ostrich feathers, Tiffany-style lamps, Victorian china pedestal jardinières, and even—in Biba’s third shop—the Victorian gothic paneling from a recently relocated boys’ school.

The clothes were subtly period, too. Minidresses looked like something out of Mabel Lucie Atwell, childishly high-waisted, with sleeves tight at the shoulder but ballooning out toward the cuff. Trousers flapped out at the hem, like men’s “Oxford bags” of the 1920s; slithery satin evening dresses looked like gowns Jean Harlow might have worn in a 1930s’ Hollywood melodrama. Then there were T-shirts, exaggeratedly long of hem and sleeve, and knee-high suede boots all in matching offbeat



colors of dirty pink, brick dust, sage green, aubergine, and chocolate; and a makeup range that made the wearer look like the silent film star Theda Bara, with black lips and glistening eyes.

Biba was a way of life as much as a dress shop, and its greatest moment became its ultimate tragedy. From the original shop, it moved—still in Kensington—first to a grocer's shop, retaining all the period wooden shelving, then to a yet larger shop that had been a school outfitters, and finally to what had been Derry and Toms department store, a fabulous art deco building, complete with roof garden and all the original fittings, carpets, and staircases. On these five floors, Biba aimed to sell not just clothes but a whole lifestyle. As well as the dresses, there were to be aubergine refrigerators, Biba dinner services, art deco carpets, a food department complete with coffee, tea, flour, and sugar in Biba packaging, and—on the ground floor—all manner of trinkets, purses, scarves, accessories and, of course, the makeup range.

It was a magnificent vision. Unfortunately the hordes of young women who came to hang out among the satin bolsters on the tiger-print sofas of the ground floor, with its dark walls and druggy ambience, did not necessarily come to buy but simply to be Biba. By this time, Barbara Hulanicki and her husband had lost financial control of the enterprise to the multichain fashion company Dorothy Perkins, and the returns were not high enough to satisfy its board of directors. In 1975 Biba folded—and not only that; in an act of the utmost philistinism, the magnificent original Derry and Toms interiors were destroyed to make way for a utilitarian Marks & Spencer and British Home Stores.

Barbara Hulanicki and her husband moved to the United States, and Hulanicki made a second successful career designing interiors for the art deco mansions of Miami, Florida. In 1993, the Laing Art Gallery in Newcastle decided to hold a Biba exhibition. Many Biba aficionados previously donated the outfits they had treasured for thirty years. There were examples of the coffee—and even baked bean—tins, the cosmetics, and the soft furnishings, and the interiors of the shops were re-created. But what was extraordinary about the exhibition was the visitors' book. Visitors were invited to comment in any way they wished. Unlike other visitors' books, its pages were filled with loving reminiscences of how a Biba outfit had defined a major experience, a period, an identity, and although Biba the shop spanned only a decade, the memory gave promise of living on forever.

See also **Boutique; Clark, Ossie; Quant, Mary; Twiggy.**

#### BIBLIOGRAPHY

Fogg, Marnie. *Boutique: A '60s Cultural Icon*. London: Phaidon Press Ltd., 2003.

Hulanicki, Barbara. *From A to Biba*. London: Hutchinson, 1983.

*Elizabeth Wilson*

**BICYCLE CLOTHING** The bicycle was invented in Europe, but American ingenuity increased its usability and widespread use. Kirkpatrick Macmillan of Scotland is credited with inventing the first mechanical bicycle, while Pierre Michaux and son Ernest of Paris were the first to manufacture bicycles on a large scale in the mid-1860s. The aptly named “boneshaker” or velocipede was quickly followed by the high-wheeler and then the safety bicycle. In July 1865 Pierre Lallement brought the bicycle to America resulting in a wave of bicycle-related patents. The bicycle craze flourished through the end of the century. Clothing specifically designed for wear while bicycling has changed dramatically over the years.

Early bicycle riding was a man's activity due to the fact that in order to ride the velocipede, essentially two wheels connected by a frame and suspended seat, the rider had to wear bifurcated apparel to straddle the mechanism. With the introduction of the pneumatic tire in 1888, the popularity of the bicycle for transportation and leisure increased dramatically. In the same year the drop-frame bike was introduced in America. This new model made bicycle riding in a skirt much easier and more women participated in the activity. By the 1890s, clothing developed specifically for bicycling was being designed and produced. Racing clubs for men were formed and appropriate attire was required. Typical clothing included the “wheelman” or sleeveless vest with insignia worn over a shirt, long shorts (to the knee), and shoes without socks. In 1874 Charles Bennet, an avid bicyclist, decided to tackle “the delicate problem that men faced as they were jounced on their penny farthings” (Norcliffe, p. 128). He designed the “bike web,” a knit and elastic garment to provide support and cushioning. Because the garment was worn by bicycle “jockeys” it was called the “jockey strap,” soon shortened to “jock strap.” Headgear and footwear were also designed specifically for bicyclists. Headgear varied from a small flat crown hat with visor brim to a pith helmet that might provide protection in a crash. Shoes were designed to prevent slipping on the bike pedals. One shoe model incorporated leather pleats on the sole that served this function.

Mid-Victorian society did not approve of women riding bicycles, but the activity became more accepted after 1881 when Queen Victoria ordered tricycles for her daughters. Besides the immodesty and physicality of women straddling a bicycle, the independence allowed the individual woman was unprecedented. By the late 1800s, women were becoming enthusiastic bicyclists. Soon many adventurous women started wearing shorter skirts to avoid catching them in the pedals. Barbara Schreier (1989, p. 112) declared “bicycling helped to smooth the way for future clothing changes and dramatically advanced the position of women in sports.” Knickerbockers made bicycle riding even easier for women, but the style was ridiculed as being unfeminine and unattractive. More shocking was the association of bifurcated garments and immorality. P. Russell suggests, “the forked body

astride a modern machine could be represented as an essentially sexual image” (p. 66).

By the 1920s, new trends in sportswear introduced new forms and fabrics that permeated all sports activities. The new casual lifestyle eliminated the need for specific bicycle wear. Practical, comfortable sportswear was now fashionable and accepted. From the 1920s to the 1960s bicyclists wore all varieties of readily available sportswear with the exception of professional bike racers who wore close-fitting knit tops and pants to facilitate speed.

Bicycle clothing in the early 2000s combines elements of function, fashion, and advertising. Function centers on the most aerodynamic ensemble while providing comfort for the rider. Fashion is evident in color choices while professional and leisure riders sport clothing with company names and logos. The avid bicyclist wears form-fitting shorts and jerseys with appropriate accessories. Bicycle shorts rely on properties of nylon and spandex fibers to provide the closest fit possible. A major functional feature of bicycle shorts is the pad sewn into the crotch of the shorts, providing cushioning between body and bike seat. Chamois leather was originally used for the pad, but synthetic chamois or gel inserts are used in the twenty-first century. The bicycle shirt or jersey is also body-conforming for the all-important aerodynamic form. Shirts are typically brightly colored making the rider highly visible. The well-known yellow jersey worn by the leader in the Tour de France bicycle race was introduced in 1919. The Tour de France uses other signifier color jerseys including the green “points” jersey for the race’s most consistent sprinter or points winner, the red polka-dot jersey for the most consistent climber, and the re-introduced white jersey distinguishes the best young rider.

Bicycle helmets, when properly worn, prevent head injuries and are becoming more accepted as the “look” for riders. Indeed, bicycle helmets are required wear for child bicyclists in some states. Helmets vary in cost and design, but most are aerodynamic in shape. Cycling shoes are designed with a rigid sole to efficiently transfer energy from the downward push of the leg to the ball of the foot and so to the pedal. Shoes worn by professional racers can be almost impossible to walk in as the sole of the shoe is contoured to mesh with the pedal of the bicycle. Gloves and eyewear often provide the finishing touch to the cyclist’s look. Gloves facilitate grip on the handlebars and may prevent injury in a fall. Eyewear provides protection from sun, wind, and insects.

Since the introduction of the bicycle to the general public, bicycle clothing has influenced everyday fashion. Bifurcated garments for bicycle wear in the late 1800s assisted in liberating women from cumbersome full-length skirts. The body-conforming look provided by modern materials, especially nylon and spandex knits, is evident in bicycle wear and fashion forms worn in the twenty-first century.

See also **Activewear**; **Elastomers**; **Nylon**.



**Bifurcated riding ensemble, 1895.** Women cast off long gowns in favor of more practical knickerbockers when riding bicycles. © CORBIS. REPRODUCED BY PERMISSION.

#### BIBLIOGRAPHY

- Norcliffe, Glen. *The Ride to Modernity: The Bicycle in Canada, 1869–1900*. Toronto: University of Toronto Press, 2001.
- Russell, P. “Recycling Femininity: Old Ladies and New Women.” *Australian Cultural History* 13 (1994): 31.
- Schreier, Barbara. “Sporting Wear.” In *Men and Women: Dressing the Part*. Edited by Claudia Kidwell and Valerie Steele, 93–123. Washington D.C.: Smithsonian Institution Press, 1989.
- Simpson, Claire. “Respectable Identities: New Zealand Nineteenth Century—‘New Women’—on Bicycles.” *The International Journal of the History of Sport* 18, no. 2 (2001): 54–77.

Karen L. LaBat

**BIKINI** The bikini, a two-piece bathing suit of diminutive proportions, first appeared on the fashion scene in the summer of 1946. Its impact was compared to that of the atomic bomb tests conducted that same summer by the United States at Bikini Atoll in the Pacific Islands,



**Bikini worn by actress Ursula Andress.** Made famous in the 1962 James Bond film *Dr. No*, this bikini was auctioned at Christie's auction house in London. The first bikini was worn at a Paris fashion show in 1946 but did not gain widespread acceptance until the 1960s. © AFP/CORBIS. REPRODUCED BY PERMISSION.

which was arguably the source of its name. Both the French couturier Jacques Heim and the Swiss engineer Louis Reard are credited with launching the skimpy two-piece, which they dubbed the *atome* and bikini, respectively. The French model Michele Bernardini wore the first bikini at a fashion show in Paris. Her suit consisted of little more than two triangles of fabric for the bra, with strings that tied around the neck and back, and two triangles of fabric for the bottom, connected by strings at the hips.

The legendary fashion editor Diana Vreeland dubbed the bikini the “swoonsuit,” and declared that it was the most important thing since the A-bomb, revealing “everything about a girl except her mother’s maiden name.” Vreeland worked at the time for *Harper’s Bazaar*, which was the first magazine to showcase the bikini in America. The May 1947 issue featured a Toni Frissell photograph of a model wearing a rayon green-and-white-polka-dot bikini by the American sportswear designer Carolyn Schnurer.

Vreeland’s comments about the bikini speak to the controversy that erupted when it first appeared. Unlike its two-piece counterparts, first seen on beaches in the late 1920s and 1930s, which exposed only a small section of midriff, the bikini bared a number of erogenous zones—the back, upper thigh, and for the first time, the navel—all at once. It was almost immediately banned, for religious reasons, in such countries as Spain, Portugal, and Italy and was shunned by American women as lacking in decency. Many public parks and beaches prohibited bikinis, and wearing them in private clubs and resorts was looked upon with disfavor.

The bikini remained a taboo novelty throughout the 1950s. Made even of such unusual fabrics as mink, grass, and porcupine quills, bikinis were worn mostly by screen sirens and pin-up girls like Brigitte Bardot, Jayne Mansfield, and Diana Dors, along with sophisticates on the beaches of resorts along the Riviera. They were also showcased in bathing suit beauty contests in vacation spots like Florida and California. One-piece and more modest two-piece suits, resembling the highly structured undergarments of the period, held favor with the majority of women until the end of the decade, when bikini sales started to rise.

An increased number of private pools in suburban backyards and a growing awareness of health and fitness were cited as possible causes for increased acceptance of bikini-wearing, at least within the privacy of one’s own home. *Harper’s Bazaar* touted the bikini as putting one close to the elements. American retailers, however, who reportedly sold more sleepwear resembling bikinis than actual bikini swimsuits, were ambivalent about the extent to which they should promote the sale of bikinis.

It was not until the 1960s that the bikini gained more widespread acceptance. Youth culture, celebrity endorsements, and innovations in textile technology such as the manufacture of spandex, helped establish the bikini, and its variations, as a mainstay in swimwear fashion. In 1960, the singer Brian Hyland immortalized the bikini with his hit song, “Itsy Bitsy Teenie Weenie Yellow Polka Dot Bikini.” A crop of beach movies with bikini-clad teenagers, including the former Mouseketeer Annette Funicello, appeared. Ursula Andress wore one of the most famous bikinis, with a hip holster, in the 1962 James Bond film *Dr. No*—a variation of which was worn by Halle Berry in the 2002 Bond movie *Die Another Day*. *Sports Illustrated* published its first swimsuit issue in 1964, with Babette March wearing a bikini on the cover; appearing on the cover of *Sports Illustrated’s* much-anticipated, annual swimsuit issue is now a coveted rite of passage for fashion models. The prevailing form of the early 1960s bikini was a structured bra top and low-slung, hip-hugging briefs, often embellished with ruffles and fringe.

Relaxing sexual mores and shifting views on modesty brought about more daring variations of the bikini in the late 1960s and early 1970s. In 1964, the American fashion designer Rudi Gernreich, whose progressive, androgynous clothing pushed fashion’s boundaries, debuted his “monokini” or topless bathing suit. The black wool knit suit consisted of briefs with suspenders that extended between bared breasts and around the neck, reminiscent of a bathing suit illustrated in 1940 by the Italian designer Umberto Brunescelli. Gernreich sold 3,000 of the monokinis by the end of the season. He again shocked the public when he unveiled his unisex thong bathing suits in 1974, and the “pubikini” in the mid 1980s. The thong bikini, which revealed the buttocks, has since become the unofficial uniform of professional bodybuilders,



boxing ring girls who announce the rounds, and female dancers in music videos.

In 1974, the string bikini, or “tanga,” consisting of little more than tiny triangles of cloth held together with ties at the hip and around the neck and back, emerged from Rio de Janeiro. Topless bathing, which had been accepted for some time in exotic beach locales such as Rio and Saint Tropez, started to gain popularity on public beaches in the 1970s, particularly in the United States.

By the late 1970s, the bikini, which had been pushed to extremely minimal proportions, had lost some of its shock value and allure, and in response the one-piece suit came into favor again. However, new one-piece styles were strongly influenced by the bikini phenomenon. A year after Gernreich’s monokini was unveiled, “scandal suits” by Cole of California, also known as net bikinis, were popular, at once playfully revealing and concealing the body with solid patches of fabric connected with patches of net. The thong was also a clear antecedent of figure revealing one-pieces of the late 1970s and 1980s, which were cut high on the thigh, low at the neck and down the back, and open at the sides.

The trend toward less-structured, more figure-revealing suits such as the bikini corresponded with the sports and fitness craze that emerged in the 1970s and 1980s. Sport bikinis with racer-back tops and high-cut briefs appeared in the 1980s and were popular into the 1990s, worn, for example, as the official uniform for women’s volleyball teams in the 1996 Olympics. In the twenty-first century, the bikini has regained popularity through new incarnations, many of which are, paradoxically, made with more fabric.

The “tankini,” a two-piece that can provide as much coverage as a one-piece, has appeared, along with the “boy short” bottoms and surfer styles reminiscent of 1960s bikinis. High-end fashion houses such as Chanel, which debuted its minimal “eye-patch” bikini in 1995, contributed to the surfer craze with logo-emblazoned bikinis and surfboards in their Spring/Summer 2002 collection.

Despite the initial controversy, the bikini has become a perennial in swimwear fashion, particularly among the young. Youth-oriented culture, sexual emancipation, innovation in textile technology, an emphasis on sports and fitness, and the overarching societal shift to a more relaxed style of dress have all contributed to the bikini’s success.

See also **Swimwear; Teenage Fashions; Vreeland, Diana.**

#### BIBLIOGRAPHY

- Esten, John. *Diana Vreeland Bazaar Years*. New York: Universe Books, 2001.
- Lencek, Lena, and Gideon Bosker. *Making Waves: Swimsuits and the Undressing of America*. San Francisco: Chronicle Books, 1988.
- Martin, Richard, and Harold Koda. *Splash!: A History of Swimwear*. New York: Rizzoli International, 1990.

Poli, Doretta Davanzo. *Beachwear and Bathing-Costume*. Modena, Italy: Zanfi Editori, 1995.

Probert, Christina. *Swimwear in Vogue Since 1910*. New York: Abbeville Press, 1981.

*Tiffany Webber-Hanchett*

**BLAHNIK, MANOLO** Manolo Blahnik (b. 1942) was a designer and manufacturer of what were called “the sexiest shoes in the world”—beautiful, expensive, and highly coveted by many of the world’s most fashionable women. Heir to a tradition of luxury shoemaking epitomized by André Perugia, Salvatore Ferragamo, and Roger Vivier, Blahnik produced shoes—“Manolos,” to the cognoscenti—that became icons of the fashion culture at the turn of the



**Manolo Blahnik with actress Sarah Jessica Parker.** Manolo Blahnik’s shoe designs are popular with celebrities. © GREGORY PACE/CORBIS. REPRODUCED BY PERMISSION.



**CEO of Neiman Marcus Direct, Karen Katz.** Katz sits near a display of Manolo Blahnik shoes that are now available for purchase online. Manolo Blahnik's shoes are universally recognized. © AP/WORLD WIDE PHOTOS. REPRODUCED BY PERMISSION.

twenty-first century. In the words of retailer Jeffrey Kalinsky, "There's never been a shoe designer whose reign as No. 1 shoe designer has lasted so long. His hold on the throne has no sign of doing anything but growing" (Larson, p. 6).

Manolo Blahnik was born on 27 November 1942 in the small village of Santa Cruz de la Palma in the Canary Islands, where his family—his Spanish mother, Manuela, his Czechoslovakian father, Enan, and his younger sister, Evangelina—had a banana plantation. Manuela, a voracious consumer of fashion magazines, bought clothes on shopping trips to Paris and Madrid and had the island's dressmaker copy styles from fashion magazines. She designed her own shoes with the help of the local cobbler.

Manolo Blahnik moved to Geneva at the age of fifteen to live with his father's cousin. Here he had his first experiences of the theater, opera, and fine restaurants. He studied law for a short period but soon switched to literature and art history. Blahnik left Geneva for Paris in 1965 to study art and theater design. He worked at the trendy Left Bank shop GO, where he met the actress Anouk Aimée and the jewelry designer Paloma Picasso.

With Picasso's encouragement, Blahnik soon moved to London. While working at Feathers, a trendy boutique, he continued to cultivate his connections to the worlds of fashion and culture and was known for his unique style. But Blahnik was still searching for a specific vocation; the search then took him to New York City.

Blahnik arrived in New York City in 1969. Hired by the store Zapata, he began designing men's saddle shoes. In 1972 Blahnik was introduced to Ossie Clark, then one of London's most fashionable designers, who asked him to design the shoes for his women's collection. While the shoes were not commercially successful, the press noticed their originality of design. Blahnik had no formal training as a shoe maker and initially his designs were structurally weak. He consulted with a London shoe manufacturer in order to correct his lack of technical skills. Also during this time Blahnik met Diana Vreeland, who declared, "Young man, do things, do accessories. Do shoes" (McDowell, p. 84). This endorsement was seconded by China Machado, the fashion editor of *Harper's Bazaar*. *Women's Wear Daily* proclaimed Blahnik "one of the most exotic spirits in London" in 1973, and *Footwear News* described the Manolo Blahnik shoe on its front



### EXCELLENCE IN DESIGN

Manolo Blahnik won three awards from the Council of Fashion Designers of America in the 1980s and 1990s. The first special award was given in 1987; the second, for outstanding excellence in accessory design, in 1990. The third award came with the following tribute in 1997: "Blahnik has done for footwear what Worth did for the couture, making slippers into objects of desire, collectibles for women for whom Barbies are too girlish and Ferraris not girlish enough .... an incredible piston in the engine of fashion, there is almost no designer he has not collaborated with, no designer who has not turned to him to transform a collection into a concert."

page as "the most talked about shoe in London." Blahnik purchased Zapata from its owner in 1973. In 1978 he introduced a line exclusive to Bloomingdale's, a well-known American retailer. Blahnik opened a second free-standing store a year later on New York's Madison Avenue.

Blahnik's creations received considerable publicity in the early 1980s, but his business was not running smoothly. Searching for alternatives, he was introduced by Dawn Mello, the vice president of Bergdorf Goodman, to an advertising copywriter named George Malkemus. Malkemus and his partner, Anthony Yurgaitis, went into business with Blahnik in 1982. They closed the Madison Avenue shop, opened a store on West Fifty-Fourth Street, and limited the distribution of Blahnik's shoes to such prestigious retailers as Barneys, Bergdorf Goodman, and Neiman Marcus. By 1984 the newspaper *USA Today* projected earnings of a million dollars for the New York shop alone. Manolo Blahnik shoes began to appear on the runways of designers from Yves Saint Laurent, Bill Blass, and Geoffrey Beene to Perry Ellis, Calvin Klein, Isaac Mizrahi, and John Galliano.

Manolo Blahnik's shoes became more popular than ever in the early twenty-first century. They appealed to an increasingly broad audience, in part because of their star billing on the television show *Sex and the City*. With production of "Manolos" limited to 10,000 to 15,000 pairs per month by four factories outside of Milan, the demand for these shoes exceeded the supply.

The December 2003 issue of *Footwear News* quoted Alice Rawsthorn, the director of London's Design Museum, which had been the site of a recent Blahnik retrospective: "Technically, aesthetically and conceptually, he is one of the most accomplished designers of our time in

any field, and is undeniably the world's most influential footwear designer" (Annis, p. 16).

*See also* Clark, Ossie; Ferragamo, Salvatore; London Fashion; Shoes, Women's; Vreeland, Diana.

### BIBLIOGRAPHY

Annis, Elisa. "Prince Charming." *Footwear News*, 8 December 2003.

Larson, Kirsten. "Blahnik Holds Reins Tight on His Manolos." *Footwear News*, 10 November 2003.

McDowell, Colin. *Manolo Blahnik*. New York: HarperCollins, 2000.

Reed, Julia. "Walk This Way." *Vogue*, November 2003.

Liz Gessner

**BLASS, BILL** William Ralph (Bill) Blass (1922–2002) was born in Fort Wayne, Indiana, in 1922. At the age of nineteen he left the Midwest and moved to New York City, where he studied briefly at Parsons School of Design. He worked as a sketch artist for a sportswear firm in 1940–1941, but his budding career was interrupted for military service in a counterintelligence unit in World



**Bill Blass.** Blass's classic use of pinstripes and houndstooth checks, along with his tailored designs, drew attention from fashionable celebrities like Nancy Reagan and Barbara Walters. In the 1980s, Bill Blass Ltd. expanded to include sales of eyeglasses, fragrances and other fashion-related merchandise. © BETTMANN/CORBIS. REPRODUCED BY PERMISSION.



War II. After the war Blass began working as a fashion designer, mainly for the firm of Maurice Rentner, Ltd. In 1970 he purchased the Rentner firm, renamed it Bill Blass Ltd., and saw the company take off as one of the most successful American fashion houses of the late twentieth century.

Blass created a glamorous but restrained look that won him a faithful following among women of style, including Nancy Reagan, Barbara Bush, Candice Bergen, and Barbara Walters. His day outfits drew heavily on tailoring and fabrics usually associated with menswear, including pinstriped gabardines, worsteds, and houndstooth checks. His eveningwear referenced Hollywood glamour. One of his most famous evening gowns consisted of a cashmere sweater top and a bouffant satin skirt.

Blass showed great business acumen in making Bill Blass Ltd. one of the leaders of the licensing boom that took off in the fashion industry in the 1980s. In rapid succession the firm concluded lucrative licensing deals for eyeglasses, executive gifts, fragrances, and a wide range of other fashion-related products. Blass retired from his business after suffering a stroke in 1998, and the company was sold to its backers in 1999. Blass died in 2002, but Bill Blass Ltd. continued to thrive, with Lars Nilsson as the founder's first successor. Michael Vollbracht replaced Nilsson as the firm's chief designer in 2003.

*See also* **Celebrities; Fashion Marketing and Merchandising; First Ladies' Gowns; Perfume; Twentieth-Century Fashion.**

#### BIBLIOGRAPHY

- Blass, Bill. *Bare Blass*. New York: HarperCollins, 2002.
- Daria, Irene. *The Fashion Cycle: A Behind-the-Scenes Look at a Year with Bill Blass, Liz Claiborne, Donna Karan, Arnold Scaasi, and Adrienne Vittadini*. New York: Simon and Schuster, 1990.
- O'Hagen, Helen, Kathleen Rowald, and Michael Vollbracht. *Bill Blass: An American Designer*. New York: Harry N. Abrams, 2002.
- Wilson, Eric. "Bill Blass Receives a Retrospective." *Women's Wear Daily*, 16 May 2000.

*John S. Major*

**BLAZER** Possibly a development of the nautical reefer jacket, a blazer is a loose-fitting and lightweight flannel sports jacket. Coming in both double- or single-breasted styles, although most are double-breasted, a blazer is generally tailored in either plain navy or black, has brass buttons, two side vents, is thigh length and in many cases has a breast-pocket badge. A well-constructed blazer can make even a pair of jeans appear smart. The blazer is generally considered to be a vital component of the "preppy" or "British look."

#### History

The familiar navy blazer traces its origins back to the captain of the frigate HMS *Blazer*, who had short double-breasted jackets cut in navy blue serge for his scruffy-looking crew when Queen Victoria visited his ship in 1837. The crew's "blazers" with their shining brass Royal Navy buttons impressed the Queen and soon became part of their dress uniform.

It is believed that the heavier double-breasted reefer jacket was the inspiration for the captain's original blazer design. What is less clear is how and why the naval blazer came to be worn by civilians. One likely explanation, and probably why so many owners of yachts and other sailing vessels wear blazers, is that many people who had no obvious association with the sea or indeed the navy could still have blazer jackets made originally for maritime experiences. With traditional outfitters such as Gieves and Hawkes, on London's Savile Row, cutting blazers for Royal Naval officers it is likely that many civilians would get their own tailors to copy a version for them. If buttons with emblems were not used then simple flat brass buttons were, although it would then become difficult to distinguish the blazer from the other sports jackets.

Divorced from any military background, the single-breasted blazer was the favored style of club jacket worn by rowing clubs in the nineteenth century. These would be made up in college, school, or club colors to be worn at special outdoor sporting events, such as the Henley Royal Regatta. Crests and other insignia were often embroidered in heavy gold thread on the left breast pocket, and the buttons were similar to those used by the navy. Men who were not in a sporting club might still wear a blazer but, as with the naval-inspired version, more likely using enamel buttons instead of brass.

Worn by many Europeans for both work and leisure and popularized by Brooks Brothers for the American market in the early twentieth century (and later in bright colors, such as bottle green or yellow, for golf attire), the authentic British blazer (and its imitations) have held a minor but consistent place in the male wardrobe for decades. The blazer's most recent revival was as essential executive dress in the 1980s, often worn with open shirt and cravat. Its popularity is limited somewhat by its reputation as being too formal for the young, and too stuffy for the "casual dress" office.

*See also* **Jacket; Sports Jacket.**

#### BIBLIOGRAPHY

- Amies, Hardy. *A,B,C of Men's Fashion*. London: Cahill and Company Ltd., 1964.
- Byrde, Penelope. *The Male Image:—Men's Fashion in England 1300–1970*. London: B. T. Batsford Ltd., 1979.
- Chenoune, Farid. *A History of Men's Fashion*. Paris: Flammarion, 1993.

- De Marley, Diana. *Fashion for Men: An Illustrated History*. London: B. T. Batsford Ltd., 1985.
- Keers, Paul. *A Gentleman's Wardrobe*. London: Weidenfeld and Nicolson, 1987.
- Roetzel, Bernhard. *Gentleman: A Timeless Fashion*. Cologne, Germany: Konemann, 1999.
- Schoeffler, O. E., and William Gale. *Esquire's Encyclopedia of 20th Century Fashions*. New York: McGraw-Hill, 1973.
- Wilkins, Christobel. *The Story of Occupational Costume*. Poole: Blandford Press, 1982.

Tom Greatrex

**BLOOMER COSTUME** In the spring of 1851, three leading women's rights activists, Elizabeth Cady Stanton (1815–1902), Cady's cousin, Elizabeth Smith Miller (1822–1911), and Amelia Jenks Bloomer (1818–1894), editor of the *Lily, a Ladies' Journal Devoted to Temperance and Literature*, wore similar outfits on the streets of Seneca Falls, New York—ensembles consisting of knee-length dresses over full trousers. In nineteenth-century America, trousers were an exclusively male garment and women wearing trousers in public caused a sensation. The national press quickly linked this dress reform style to Amelia Bloomer, who had been writing articles about it. Soon both the costume and its wearers were popularly identified as “Bloomers.”

Amelia Bloomer's strong association with the freedom dress, as it was known by women's rights advocates, began with an article in the *Lily* in February 1851. Bloomer wrote more pieces about the outfit over the next several months, particularly emphasizing its advantages as a healthful, convenient alternative to the many petticoats, long skirts, and tight corsets of current fashionable dress. In response to readers' inquiries, Bloomer described the costume in detail in the *Lily's* May issue, and when it sold out, repeated the description the following month, stating:

Our skirts have been robbed of about a foot of their former length, and a pair of loose trousers of the same material as the dress, substituted. These latter extend from the waist to the ankle, and may be gathered into a band . . . We make our *dress* the same as usual, except that we wear no bodice, or a very slight one, the waist is loose and easy, and without whalebones . . . Our skirt is full, and falls a little below the knee.

But however closely she was connected with the Bloomer costume by the press and the public, Amelia Bloomer did not invent the style. Bloomer's full trousers gathered in at the ankle were called “Turkish trousers” and patterned after those worn by women in the Middle East. Since the eighteenth century, European and American women had also worn such trousers for fancy dress. French fashion plates of the 1810s show similar full trousers, called pantalets or pantaloons, peeking out un-

der calf-length fashionable dresses. Although this style was far too daring for American women, by the 1820s children of both sexes were wearing short dresses over narrow, straight-legged trousers, also called pantalets. Boys exchanged pantalets for regular trousers when they grew too old for dresses (typically at five or six), while girls wore them throughout childhood. In their late teens, girls graduated to long dresses and continued to wear pantalets as underwear beneath their skirts.

Amelia Bloomer credited Elizabeth Smith Miller with introducing the freedom dress. There are differing accounts of how Miller came to design her outfit, but it is likely that Miller was aware of similar attire worn by women in utopian communities or sanatoriums. Beginning in 1827 with Community of Equality in New Harmony, Indiana, women in several American religious and utopian groups wore straight-legged trousers like children's pantalets under knee-length loose-fitting dresses. Various styled similar outfits were also promoted for women performing calisthenic exercises and patients at water cure sanatoriums. These early instances of women wearing short dresses over trousers did cause occasional comment in the press, but because the garments were worn in closed societies or in women-only situations, they did not challenge the basic social order, unlike the public displays of the Bloomer costume in the 1850s.

The initial press coverage of Bloomer wearers during the summer of 1851 was not completely negative but before long the reality of women publicly wearing trousers brought out underlying fears of gender role reversals. In a society based on male dominance and female submission, men saw the Bloomer costume as a threat to the status quo and male leaders from newspaper editors to ministers decried the fashion. Satirical cartoons depicted Bloomer-clad women as crude louts indulging in the worst male vices or bossy wives holding sway over their husbands.

Although women's rights activists generally favored dress reform, they came to view the Bloomer costume as a counterproductive force. When activists lectured wearing the Bloomer costume, audiences focused on the controversial trousers instead of radical change in women's education, employment, and suffrage. Consequently, by the mid-1850s, most women's rights advocates had stopped wearing the Bloomer costume in public. Amelia Bloomer herself continued to wear it until 1858, when she cited a move to a new community and the newly introduced cage crinoline, which eliminated the need for heavy petticoats, as the reasons she abandoned the freedom dress and returned to long skirts.

The Bloomer costume and a similar outfit called the American costume, which featured mannish, straight-legged trousers, were viable alternatives to constrictive fashionable dress during the second half of the nineteenth century. Although the number of women who wore such attire in public was very small, there are accounts of

*à Mademoiselle Rosalie W. Taylor.*

# THE BLOOMER QUICK STEP



*Lith. by A. Hoen & Co. Balt.*

Composed by  
**CHARLES GROBE.**

*Colours 38 cts. net.* Baltimore pub. by F. D. Benteen.  
W<sup>m</sup> T. Mayo, New Orleans. *Plain 25 cts. net.*

**The Bloomer Quick Step.** The "Bloomer" described in the *Daily Richmond Times* account wore an outfit similar to the one seen on the girl illustrating the "Bloomer Quick Step." A publisher of dance scores apparently mistook the Bloomer costume as a fashion fad and released a series of illustrated "Bloomer" dances late in 1851. LIBRARY OF CONGRESS. REPRODUCED BY PERMISSION.





Yesterday afternoon, Main street was thrown into intense commotion by the sudden appearance . . . of a pretty young woman, rigged out in the Bloomer costume—her dress being composed of a pink silk cap, pink skirt reaching to the knees and large white silk trousers, fitting compactly around the ankle, and pink coloured gaiters. . . . Old and young, grave and gay, descended into the street to catch a glimpse of the Bloomer as she passed leisurely and gracefully down the street, smiling at the sensation which her appearance had created. The boys shouted, the men laughed and the ladies smiled at the singular spectacle. . . . Few inquired the name of the Bloomer, because all who visited the Theatre during the last season, recognized in her a third or fourth rate actress, whose real or assumed name appeared in the bills as “Miss O’Neil.” During the Season, however, we learn she severed her connexion with Mr. Potter’s corps of Super numeraries and entered a less respectable establishment in this city.

*Richmond Dispatch*, Tuesday, 8 July 1851, p.2, c.6.

women wearing it in private when doing housework, farming, or traveling, especially in the west. In 1858 *Godey’s Lady’s Book* promoted a Bloomer-style costume for calisthenics and similar clothing was worn as bathing costume. Physical training educators used the Bloomer costume as a prototype in developing garments for increasingly active women’s sports programs. The full trousers themselves became known as bloomers and, by the 1880s, were an essential element of the gymnasium or gym suit; short bloomers continued to be worn as part of gym suits into the 1970s. Bloomers reappeared in public during the bicycling craze of the 1890s, now worn as part of a suit with a jacket instead of a short dress. Women wearing bicycling bloomers in the 1890s were less controversial than when Amelia Bloomer and her friends donned their famous outfits in the 1850s, but not until the mid-twentieth century did women routinely wear trousers in public without criticism.

See also **Dress Reform; Gender, Dress, and Fashion; Trousers.**

#### BIBLIOGRAPHY

- Bloomer, Amelia. *The Lily, a Ladies’ Journal Devoted to Temperance and Literature*. The February, March, April, May, and June 1851 issues of *The Lily* have articles by Amelia Bloomer related to female dress reform.
- Cunningham, Patricia A. *Reforming Women’s Fashion, 1850–1920: Politics, Health, and Art*. Kent, Ohio, and London: Kent State University Press, 2003. Comprehensive

social history of women’s dress reform with an excellent overview of the role of the Bloomer costume.

Fischer, Gayle V. *Pantaloon and Power: A Nineteenth-Century Dress Reform in the United States*. Kent, Ohio, and London: Kent State University Press, 2001. Detailed analysis of the cultural role of trousers in nineteenth-century American society.

Sims, Sally. “The Bicycle, the Bloomer and Dress Reform in the 1890s.” In *Dress and Popular Culture*. Edited by Patricia A. Cunningham and Susan Vosco Lab, 125–145. Bowling Green, Ohio: Bowling Green State University Popular Press, 1991. Article about women wearing bloomers during the bicycle craze of the 1890s.

Colleen R. Callahan

**BLOUSE** Although the term “blouse” now refers to a woman’s separate bodice of a different material than the skirt, the word derives from the French name for a workman’s loose smock and was first used in English for men’s and boy’s shirts. The feminine blouse has its antecedents in the undergarment known as a smock, shift, or chemise, which served the same purposes as the male shirt: worn next to the skin, it absorbed bodily soil and protected outer garments.

In the early 1860s full-sleeved loose bodices came into vogue, called Garibaldi shirts since they were modeled on the famous red shirt of the Italian nationalist and freedom fighter. *Peterson’s Magazine* in May 1862 (p. 421) thought these blouses, often made in red or black wool or white or striped cotton, were warm, comfortable, inexpensive, and practical, extending the life of a silk skirt which outlived its matching bodice. Puffed “in bag fashion” at the waist, Garibaldi shirts sometimes created an ungainly silhouette with a hooped skirt, but a boned waistband called a Swiss belt could be worn to gracefully ease the transition between top and bottom. The idea of fashionable separates for women had emerged. In January 1862 *Godey’s Lady’s Magazine* (p. 21) predicted that the advent of the feminine shirt was “destined to produce a change amounting to a revolution in ladies’ costume.”

By the 1890s, these bodices, now called shirtwaists or waists, had indeed dramatically increased the average woman’s clothing options. Shirtwaists could be severely tailored with masculine-style detachable starched collars and cuffs, or very feminine in lightweight fabrics trimmed with lace, insertion, and other lavish decoration. Shirtwaists were suitable with tailored suits, with a skirt for housework and sportswear, and with bloomers for cycling or as gym costumes, while dressier versions were worn for afternoon receptions, the theater, and evening wear. In 1895, Montgomery Ward’s spring and summer catalog (p. 37) told customers, “Your old dress skirt worn with a neat laundered waist provides you with a cool, comfortable and up-to-date costume that will quite astonish you.” They commended the shirtwaist as “by far

the most becoming and sensible article of woman's attire to receive fashion's universal approval."

Although they could be made at home and commercial patterns were widely available, shirtwaists, with their loose fit, were the first women's garment to be successfully mass-produced. Ready-made waists could be purchased at incredibly low prices—as little as twenty-five cents from Sears, Roebuck and Company in 1897. The burgeoning apparel industry utilized economies of scale and power machinery, but cheap garments were also the result of sweatshop production by unskilled and often exploited labor. Workers could toil seventy hours a week for as little as thirty cents a day, frequently in egregious conditions.

One of the many sweatshops in Manhattan churning out these popular garments was the Triangle Shirtwaist Company, which occupied the top three floors of a ten-story building and ensured maximum production by locking the exit doors. When fire broke out on 25 March 1911, many of the 500 workers, mainly Jewish immigrants aged thirteen to twenty-three, were trapped; 146 women died in less than fifteen minutes. While this tragedy helped crystallize calls for reform, led by organizations such as the International Ladies Garment Workers Union founded in 1900, mass production continued to create victims as well as affordable clothing.

Many sweatshop workers no doubt wore shirtwaists, for these practical, inexpensive, and unobtrusive garments were a boon to women in factories, offices, and those who would later be dubbed "pink collar" workers. Yet at the turn of the century, the well-to-do, imperiously handsome women immortalized by illustrator Charles Dana Gibson were often depicted wearing immaculate starched shirtwaists during vigorous walks or rounds of golf. The "Gibson girl" soon became such an American icon that she gave her name to styles of waists and the preferred high stand collars. As fashion evolved, shirtwaists gradually became more relaxed; by the 1910s the "middy blouse," modeled on the loose sailor-collared shirts of seamen, was especially popular with girls and for general sport and utility wear.

The shirtwaist, now also called a blouse, proved remarkably accommodating in style and price. By 1915 Gimbel's catalog (p. 44) could state, "The shirtwaist has become an American institution. The women of other lands occasionally wear a shirtwaist—the American woman occasionally wears something else." Mass-produced or custom-made, serviceable or dainty, the versatile blouse played an essential role in the democratization of fashion. *Suiting Everyone* (Kidwell and Christman, p. 145) states, "For the first time in America, women dressed with a uniformity of look which blurred economic and social distinctions."

While not as universally worn, the feminine blouse adapted itself to almost every occasion through the mid-twentieth century. The haute couture ensembles of ele-

gant matrons often featured blouses to match suit jacket linings, while college girls coordinated Peter-Pan collared permanent-press blouses with casual skirts or slacks. As more women joined the labor force—nearly a third of the American labor force was female by 1960—the blouse continued to be the workhorse of clerical workers, teachers, and those in service industries. In 1977 John T. Molloy in *The Woman's Dress for Success Book* (pp. 54, 55) famously advocated a "uniform" for the executive woman consisting of a skirted suit and blouse—but warned that removing the jacket would make her look like a secretary. He argued that since the blouse made a measurable difference in the psychological impact of the suit, it should not be selected for emotional or aesthetic reasons, but for its message. Molloy claimed his research showed a white blouse gave high authority and status, and his recommended styles included man-tailored shirts with one button open and the "acceptable nonfrilly style" with a built-in bow tie at the neck—the so-called floppy bow that soon became a "dress for success" cliché.

While blouses were important in reflecting the wearer's personal style, this message was sometimes oversimplified. Toby Fischer-Mirkin's 1995 book *Dress Code* (p. 94), for example, definitively states that an unbuttoned shirt collar indicates an open-minded, flexible woman, a loose collar reflects a casual woman who may be slack in her work, while an angular or oddly shaped collar proclaims a highly creative and unconventional individual.

In the late twentieth and early twenty-first century, the blouse—like the earlier Garibaldi shirt and shirtwaist—has been overshadowed by trendier permutations of feminine tops, from T-shirts and turtlenecks to sweaters and man-tailored shirts. Introduced less than one hundred and fifty years ago, the concept of women's separates has become a democratic sartorial style.

See also **Shirtwaist; T-Shirt.**

#### BIBLIOGRAPHY

- 1897 *Sears Roebuck Catalogue*. Reprint edited by Fred L. Israel. New York: Chelsea House Publisher, 1968.
- Fischer-Mirkin, Toby. *Dress Code*. New York: Clarkson Potter, 1995.
- Gimbel's Illustrated 1915 Fashion Catalog*. Reprint, New York: Dover Publications, Inc., 1994.
- Kidwell, Claudia B., and Margaret C. Christman. *Suiting Everyone: The Democratization of Clothing in America*. Washington, D.C.: Smithsonian Institution Press, 1974.
- Molloy, John T. *The Woman's Dress for Success Book*. New York: Warner Books, 1977.
- Montgomery Ward & Company's Spring and Summer 1895 Catalogue*. Reprint, New York: Dover Publications, Inc., 1969.
- Schreier, Barbara A. *Becoming American Women: Clothing and the Jewish Immigrant Experience, 1880–1920*. Chicago: Chicago Historical Society, 1994.

H. Kristina Haugland

**BODYBUILDING AND SCULPTING** The twenty-first century body, like those of preceding centuries, is still engaged in the eternal quest for an ideal shape. The modernist body of fashion has made it possible for both women and men to reconstruct themselves by a variety of means, resisting the body's unruly nature in order to achieve a firm, toned physique that conforms to sexual stereotypes and concepts of beauty. While women in earlier centuries relied mainly on dieting and corsetry to achieve the perfect shape, today's alternatives include muscular development through weight-lifting, strenuous exercise, and perpetual dieting. Cosmetic surgery has become an accepted method of transforming the body's natural shape. Many contemporary men rely on strenuous weight training, other forms of exercise, dieting, and cosmetic surgery to achieve bodies that conform to social ideals of masculine appearance.

During the latter half of the twentieth century, women in the developed world came to rely on medical science for regular health screening and routine medical procedures. The medicalization of the female body continued, and by the beginning of the 1990s plastic surgery was widespread and surgery became a "normal" means of fashioning the body. Whereas body-shaping fashions had merely manipulated the body into an ideal shape temporarily, the surgeon's scalpel could achieve enduring transformations intended to boost both the patient's self-esteem and her social desirability. Whereas during the early years of cosmetic surgery many women would be at pains to conceal the fact that they had undergone a face-lift or other procedure, toward the end of the twentieth century such surgery was socially acceptable and even regarded as glamorous.

That such radical procedures have nevertheless become commonplace is explained by a combination of the ever-increasing technical ability to perform them and the continually evolving notion of the ideal female body. Prior to the 1960s, changes in the ideal female form were more likely to have been achieved by clothing than by physical transformations of various sorts. The emergence of the "New Woman" in the late nineteenth century introduced an element of athleticism into the feminine ideal, even as corsets continued to be worn on the sports field. The ideal of the 1920s was youthful and trim, but women of the 1930s through the 1950s were shaped by elastic undergarments.

By the 1960s, perceptions of femininity were aligned to ideals of youth, and a fixation with the adolescent figure resulted in a very thin, androgynous physique often achieved by extremes of dieting. Dieting prevailed throughout the 1970s as the principal means of body modification, augmented by exercise regimes of jogging, tennis, and roller-skating, which gave way to aerobics, dancercise, and fitness classes in the 1980s. The lithe but shapely physiques of Jane Fonda and Cindy Crawford represented the sought-after ideal, which fashion augmented with shoulder pads and bulky "box" jackets that

produced the appearance of a voluptuous, powerful physique. In the 1990s, the use of exercise and diet to achieve an ideal shape was increasingly supplemented by medical and surgical procedures. One group of women, however, took exercise itself to extreme levels.

The phenomenon of female bodybuilding, which had existed since the mid-twentieth century but only emerged from its subcultural milieu in the 1980s, introduced a rippling range of hyper-muscular bodies to the wider context of visual culture. Women with bulging thighs, enormous calves, rock-hard biceps, Herculean shoulders, and washboard abs introduced a new form of physicality that previously had only been associated with male bodybuilders or with the female superheroes of comic strips. Female mesomorphs, as women bodybuilders became known, inspired some women to strive for bodies with exceptional strength and definition.

Such physiques moved beyond the traditional stereotypes of the female body and in feminist circles were received as avatars of a future body image. While the female mesomorph was rarely seen on fashion runways, she gained ground in film and television. Programs such as *Xena: Warrior Princess* popularized the erotic appeal of muscular women and provided a role model for those striving for a similar body ideal.

Although fashion magazines typically promote weight loss and body conditioning to reinforce the image of women as being lean and toned, mesomorph bodies blur gender boundaries. This female body type reads as an emulation of masculinity, male power, and privilege. The feminist scholars Susan Bordo and Christine Battersby cite the female mesomorph as an example of the cultural difficulties over issues surrounding the body, gender, sexuality, and power. Robert Mapplethorpe photographed the bodybuilder Lisa Lyons as the AIDS epidemic grew, confronting the anxieties of a society riddled with fears of sickness and death with a representation of power and vitality.

But body modification is practiced by men as well as by women. In the Western tradition, elite male clothing has typically been body concealing, emphasizing attributes of wealth and status rather than physical form. Only in a few instances, such as the uniforms of cavalry officers, did men wear body-enhancing clothing; tellingly, the shoulder pads and corsets worn to shape their figures mirrored the dress of the early nineteenth-century dandy. By the end of the nineteenth century, however, an athletic physique, implying proficiency at such upper-class pursuits as tennis and college team sports, had begun to be considered a desirable attribute of young men. Sheer muscularity, however, remained the province of circus strongmen and manual laborers. Weight lifting, though a part of the modern Olympics since its inception, was in its infancy as a sport.

Following World War I, the gradual acceptance of men going bare-chested or nearly so while swimming in



mixed company, helped to focus attention on the muscular torso as an attribute of masculinity. Bodybuilding as a defined set of techniques soon followed. For example, Charles Atlas, who billed himself as “the world’s most perfectly developed man,” began in 1929 to market his system for turning “97-pound weaklings” into muscular giants. The first “Mr. America” contest was held a decade later, won by the bodybuilding legend Bert Goodrich.

The invention of weight-training machines, such as the Nautilus in the late 1960s and early 1970s, transformed the nature of physical exercise and made strength training readily available to men of all ages and ability levels. By the mid-1970s, men and women alike were putting in more and more time at the gym in pursuit of the ideal body. Meanwhile, bodybuilding as a sport was popularized by specialized magazines, by famous gathering spots like southern California’s “Muscle Beach,” and by a network of professional and amateur contests.

Bodybuilding is a special subculture, in which extremely massive musculature, the hypertrophic development of all of the body’s muscles (often relying in part on steroids and other metabolic enhancements), and the taking of sculptural poses tend to go far beyond mainstream society’s criteria for the masculine ideal. In some gay subcultures, bodybuilding to a lesser extreme is the norm, and having a “cut” body (one with sharply defined musculature) is highly sought after. Within those communities, implants, liposuction, and other surgical enhancements have become commonplace. Most broadly, a toned, muscular body has become a widely accepted ideal for young men in Western cultures, to the extent that not to possess such a body is as much cause for self-conscious concern as it has become for a woman not to be toned, shapely, and firm.

As these body ideals are considered, new functions and new perspectives of the fashioned body unfold. The body’s role as a site of resistance, empowerment, and emancipation reveals that the body ideals of fashion are not necessarily satisfied by the pursuit of beauty alone.

See also **Plastic and Cosmetic Surgery**.

#### BIBLIOGRAPHY

- Arnold, Rebecca. *Fashion, Desire and Anxiety*. London: IB Tauris, 2001.
- Balsamo, Annen. *Technologies of the Gendered Body*. Durham, N.C.: Duke University Press, 1977.
- Bordo, Susan. “The Body and the Reproduction of Femininity: A Feminist Approach to Foucault.” In *Gender/Body/Knowledge*. Edited by A. Jaggar and S. Bordo. New Brunswick, N.J.: Rutgers University Press, 1989.
- Frueh, Joanna, et al., eds. *Picturing the Modern Amazon*. New York: New Museum Books; Rizzoli International, 1999.
- Gaines, Charles. *Pumping Iron: The Art and Sport of Bodybuilding*. New York: Simon and Schuster, 1982.
- Ince, Kate. *Orlan: Millennial Female (Dress, Body, Culture)*. Oxford: Berg, 2000.

Nettleton, Sarah, and Jonathan Watson. *The Body in Everyday Life*. London: Routledge, 1998.

Quinn, Bradley. *Techno Fashion*. Oxford: 2002.

Steele, Valerie. *The Corset*. New Haven, Conn.: Yale University Press, 2001.

Webster, David Pirie. *Bodybuilding: An Illustrated History*. New York: Arco Publishing, 1982.

Bradley Quinn

**BODY PIERCING** Body piercing is the practice of inserting jewelry (usually metal, though wood, glass, bone, or ivory, and certain plastics are used as well) completely through a hole in the body. Piercing is often combined with other forms of body art, such as tattooing or branding, and many studios offer more than one of these services. While virtually any part of the body can be, and has been, pierced and bejeweled (for evidence, see the well-known Web site <http://www.bmezine.com>) widely pierced sites include ear, eyebrow, nose, lip, tongue, nipple, navel, and genitals.

Much of what popularly passes for the history of body piercing is in fact fictitious. In the 1970s, the Los Angeles resident Doug Malloy, an eccentric and wealthy proponent of piercing, set forth with charismatic authority a set of historical references connecting contemporary Western body piercing to numerous ancient practices. He declared, for example, that ancient Egyptian royalty pierced their navels (consequently valuing deep navels), Roman soldiers hung their capes from rings through their nipples, the *hafada* (a piercing through the skin of the scrotum) was a puberty rite brought back from the Middle East by French legionnaires, and that the *guiche* (a male piercing of the perineum) was a Tahitian puberty rite performed by respected transvestite priests. No anthropological accounts bear out these claims.

What facts can be sorted from the fiction nonetheless attest to the remarkable antiquity of piercing. The oldest fully preserved human being found, the 5,300-year-old “ice-man” of the Alps, shows evidence of ear-lobe piercing. Like many with a serious interest in piercing in the twenty-first century, the ice-man has stretched his lobes, in his case to a diameter of about seven millimeters. Artifacts as well as bodies offer evidence of ancient single and multiple ear piercings from as early as the ninth century B.C.E.

While Malloy’s claims are largely imaginative, there are geographically diverse cultures in which piercing has been continually practiced for quite some time. Ear and nose piercing seem to be, and seem to have been, the most popular; indeed, there are far too many examples to list here, and the following instances should be taken as representative rather than anything close to exhaustive. Many Native American peoples practiced ear or nose—generally septum—piercing (the latter most fa-

mously among the Nez Percé of the American Northwest). Multiple ear piercing was practiced by both men and women in the ancient Middle East, and a mummy believed to be that of Queen Nefertiti of Egypt, sports two piercings in each ear. The Maoris of New Zealand, though better known for their intricate and elegant tattoo designs, have also long practiced ear piercing, which along with nose piercing is widespread among native peoples of both New Zealand and Australia. Ear piercing for girls forms part of traditional rites in Thai and Polynesian cultures. Ear piercing among the Alaskan Tlingits could be an indication of social status, as could nose piercing.

Stretched ear piercings—in which the hole is gradually enlarged by the use of weights or by the insertion of successively larger pieces of jewelry—appear in diverse cultures as well. In Africa, the Masai and Fulani are known for ear-cartilage piercings, which may be stretched (a much slower and more difficult process than stretching earlobe piercings). Images and artifacts from native Central American cultures show stretched lobes with jewelry much like that used by contemporary enthusiasts. East Asian images and sculptures, some many centuries old, show long stretched lobes as well; these are emblematic especially of Buddhist saints. The Dayaks of Borneo traditionally pierce and dramatically stretch the earlobe; other piercings—including the *ampallang*, a horizontal piercing through the penis—have also been attributed to them.

Nostril piercing may have originated in the Middle East, and has been practiced in India for thousands of years, particularly among women. It may be through their interest in Eastern cultures that the hippies of North America took to nostril piercing around the 1970s.

While not as prevalent as the piercing of the ears or nose, lip piercing is also geographically widespread. Women in many regions of East Africa have traditionally worn lip piercings with plugs, while Dogon women may pierce their lips with rings. The men among some native Alaskan peoples also pierced the lower lip, either doubly or singly.

Other piercings are much less attested to in older or more traditional contexts. There is some indication of Central American tongue piercing, for example among the Mayas, but this may have been temporary, intended to draw blood for ceremonial purposes rather than for the lasting insertion of jewelry. More reliable is the evidence of the Indian Kama Sutra (written by the sixth century C.E.) where penis piercings resembling the contemporary *apadravya*—a vertical piercing through the penis—are described as enhancing the pleasure of both the penis-bearer and his partner.

There may also have been temporary upsurges of interest prior to contemporary versions—some sources, for example, report a fad for nipple piercings among women in the late nineteenth century in both London and Paris. (See both Kern and Harwood.) Here, as in its contem-

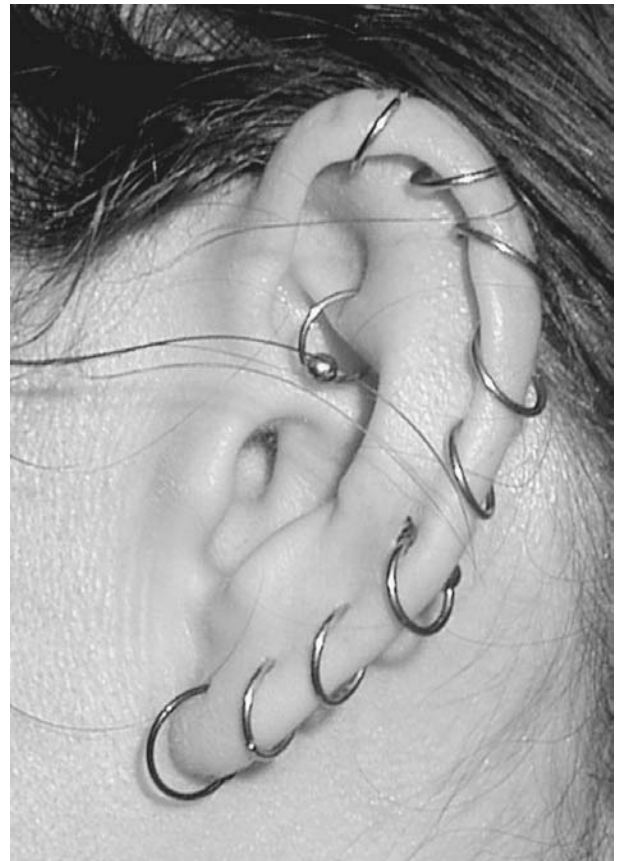

**Ear with multiple piercings.** Ear piercing is an ancient tradition dating back to prehistoric times that continues to be practiced by many traditional, as well as contemporary, cultures in the early twenty-first century. Multiple ear-piercing became popular in Western culture during the late-twentieth century among members of the punk, goth, and rave youth subcultures. COURTESY OF KARMEN MACKENDRICK. REPRODUCED BY PERMISSION.

porary form, piercing is removed from its more traditional social functions, such as marking one as a member of a community or as being of a particular status, and more specifically erotic as well as decorative functions are noted.

### Recent History and Subcultures

“Body piercing” is generally distinguished from (unstretched) earlobe piercing, and is more recent in popularity. In its late-twentieth-century version, the interest in such piercing can be traced largely to a handful of figures, particularly Doug Malloy along with Jim Ward and Fakir Musafar (Roland Loomis) in the United States and Mr. Sebastian (Alan Oversby) in the United Kingdom.

With Malloy serving as patron and in some respects teacher, Ward began making specialized piercing jewelry in the early 1970s (Ward is credited with the design of the ubiquitous captive-bead ring, also called the ball-closure ring). He and Musafar opened the Gauntlet, a

piercing shop that seemed a natural outgrowth of the jewelry business, in Los Angeles in 1975. Gauntlet shops in other major cities opened in succeeding years. Later he began the journal *PFIQ* (*Piercing Fans International Quarterly*), an important source of both information and community for those interested in body piercing. Mr. Sebastian, likewise taught at first by Malloy, was more secretive with his techniques, but was widely known as a piercer. For both, the initial clientele was largely gay men from the sadomasochistic (s/m) community.

In the 1980s, Elayne Binnie (known as Elayne Angel in the early 2000s) joined the staff of the Gauntlet, attracting many more women clients. Angel, who was the first person to obtain the “Master Piercer” certificate from the Gauntlet, is also widely credited with popularizing the tongue piercing (having five herself). Along with the navel, the tongue is one of the most popular piercings in the early twenty-first century.

Musafar, who later fell out with his former partner, is responsible for the term “modern primitive,” with which a number of highly pierced people have identified. Musafar emphasizes commonalities between contemporary and older, particularly tribal, traditions; he also emphasizes the psychological and spiritual elements of all sorts of body modifications, including piercing. Many serious piercers in the early 2000s are trained in his seminars. Modern primitives may ritualize the processes and meaning of their body art and often draw on traditional cultures for design in both piercing jewelry and other arts, such as tattooing.

From its start among gay leathermen, piercing grew in popularity to include a number of communities. Among the most influential in the spread of piercing’s popularity was punk. The punks in both the United States and the United Kingdom were fond of non-ear piercings, particularly on the face (lip, nostril, and cheek piercings attained popularity early in this group). The punk emphasis is on rebellion and unconventionality; the modern primitive emphasis on cross-cultural connection and spirituality is quite absent here, replaced by punk’s interesting combination of outrage and playfulness.

Music and cultural styles that emerged out of punk often have a place for piercing as well. The straightedge movement, generally dated to the early 1980s, though it attained more popularity later on, provides today a large subset of the heavily pierced. Along with tattoos (often of straightedge symbols such as XXX or sXe) piercings show both the punk influence on straightedge music and the subculture’s deep interest in the body (most who identify as straightedge are vegetarian or vegan and abstain from the use of alcohol and other recreational drugs). Straightedge thinking may emphasize the slightly mind-altering sensation of the piercing experience, incorporating elements of the modern primitive emphasis on ecstasies (overcoming the limits of time and selfhood in experience) alongside punk unconventionality. The Goth scene emergent in the early 1980s and again in the

1990s has a religious sensibility very different from modern primitive spirituality, tending toward highly stylized and cultivated artifice in its use of religious, particularly Catholic and Wiccan, imagery. As these associations suggest, Goth style tends toward intense theatricality, and visually striking piercings are widespread; the “dark” emphasis of much Goth culture also meets up with an acceptance of s/m imagery and the pain that may be inherent in body piercing.

The rave scene emergent in the 1990s also includes an interest in visually compelling piercings, particularly facial and navel piercings. Often glow-in-the-dark or battery-powered flashing jewelry is used, giving the piercings a hypnotic effect in dimly lit spaces and playing off the more rapid pulse of the very high beats-per-minute music generally favored.

Not all highly pierced groups or scenes are connected to particular species of music, of course. S/m communities remain strongholds of piercing. Here both the physicality of the piercing experience (and the enhanced sensation often provided by healed piercings) and the symbolism of the jewelry are significant—with the significance ranging from pain-tolerance to community affiliation to ownership. Piercing is also popular, though not so much as tattooing, in biker culture. Here large-gauge (thickness) piercings are often favored, complimenting the traditional bold lines of biker tattooing. Finally, many people also simply understand themselves as members of a body-modification or body-art community, with a respect for body modification and an interest in its being practiced well—as well as in having their own bodies modified.

### The Move to the Mainstream

Most piercers, however, will emphasize that the people who get pierced do not often fit into any of these groups, and may indeed be, for example, corporate or grandparental types whose under-the-clothes piercings almost certainly go unsuspected. The more fashionable piercings—particularly tongue, navel, nostril, and eyebrow—tend to attract a younger and more specifically (or overtly) fashion-oriented clientele. A significant influence on the entry of body piercing into mainstream fashion has been popular music, as formerly “edgy” or marginal looks were assimilated into pop and made widely visible in music videos. The most famous instance here is undoubtedly the inspirationally pierced navel of the singer Britney Spears, which has taken thousands if not millions of young women into piercing shops they might not otherwise have frequented.

In general, “mainstream” body piercing involves relatively small-gauge jewelry, often (particularly for navel piercings) with ornamental, even jeweled, beads. Gold, while expensive, may be used as well as more commonly used nonreactive metals including stainless steel and titanium. Perhaps in response, those who identify as more



marginal or as members of the body-art community tend to prize piercings that are unusual in location or style, such as surface piercings (piercings that go under the skin rather than through a protruding part of the body—the eyebrow is a surface piercing, but less common versions include the nape or front of the neck, the back along the spine, and the wrists), multiple piercings in a single location (even the navel offers top, bottom, left, and right options), or very large-gauge piercings.

As body piercing has grown in popularity, it has come to be increasingly regulated, though it is still much less so than tattooing. In most of the United States, and in parts of Canada and Australia, local legislation sets hygienic standards via departments of health, and limits the piercing permitted to minors, either banning it outright or requiring parental permission. Interestingly, earlobe piercing is almost invariably excluded from this legislation, a reflection of its well-established and unthreatening presence. The Association of Professional Piercers, a voluntary organization, promotes self-regulation regarding cleanliness standards and piercing practices, and many piercers are members.

Legislation in the United Kingdom is somewhat ambiguous, although piercing seems in general to be legal so long as its purpose is solely cosmetic. In 1991, Mr. Sebastian was found guilty of “gross bodily harm” to thirteen of his clients (they had not complained, but their names were located in his records), on the principle that one cannot assent to assault or mutilation. Cosmetic piercing is regulated in London, and ear piercing elsewhere in the United Kingdom, but it is not quite clear how or whether laws on injury, surgery, or female circumcision might apply (see Tameside Metropolitan Borough Council).

Despite occasional suggestions that the proper legislation regarding body piercing is to ban it outright, the phenomenon seems unlikely to disappear altogether. Undoubtedly its popularity will wane, perhaps to wax again at some point, but the longevity of the practice among human beings suggests that it has an enduring, as well as cross-cultural, appeal.

See also **Plastic and Cosmetic Surgery; Punk; Scarification; Tattoos.**

#### BIBLIOGRAPHY

- Camphausen, Rufus C. *Return of the Tribal*. Rochester, Vt.: Inner Traditions Ltd., 1997.
- Harwood, Bernhardt. *The Golden Age of Erotica*. New York: Paperback Library, 1968.
- Kern, Stephen. *Anatomy and Destiny*. Indianapolis, Ind.: Bobbs-Merrill Company, 1974.
- Larratt, Shannon. *ModCon: The Secret World of Extreme Body Modification*. Toronto: BME Books, 2002.
- Vale, V., and Andrea Juno. *Modern Primitives*. San Francisco: V/Search, 1989.

#### Internet Resource

- Tameside Metropolitan Borough Council. 2000. “Guidelines for the Practice of Body Piercing.” Available from <<http://www.tameside.gov.uk/licensing/bodypiercingguidelines.html>>.

*Karmen MacKendrick*

**BOGOLAN** *Bogolan*, also known as *bogolanfini*, is an African textile whose distinctive technique and iconography have been adapted to diverse markets and materials. The textile is indigenous to Mali, where it has been made and worn for generations. The cloth’s bold geometric patterns and rich earth tones make it distinctive and readily adaptable to new contexts. In the past, bogolan was made exclusively by women, who created it for use in specific ritual contexts. During the past two decades, new techniques, forms, and meanings have brought bogolan to international markets even as the cloth continues to be made and used in its original contexts. In North America, where the cloth’s patterns have been adapted to a wide range of products, this textile is marketed as “mud cloth.”

Although bogolan is associated with a number of Malian ethnic groups, it is the Bamana version that has become best known outside of Mali. *Bogolanfini* is a Bamana word that describes this textile dyeing technique; *bogo* means “earth” or “mud,” *lan* means “with” or “by means of,” and *fini* means “cloth.” Bogolan is unique both in technique and style, which makes the cloth particularly appealing to contemporary artists and designers. Many are also drawn to the fact that bogolan is uniquely Malian, made nowhere else in the world.

#### The Cultural Role of Bogolan

Until its recent revival in urban Mali, bogolan was made only by women, who learned techniques and patterns from their mothers and other older female relatives. The making of bogolan requires both technical knowledge and mastery of the cloth’s many symbols. Some bogolan artists become well-known in their communities and beyond. The recent rise in bogolan’s popularity has changed the lives of some of these women, who now sell cloth to art collectors and teach aspiring bogolan artists, who are primarily young men from Bamako, the capital of Mali.

The cloth’s traditional uses reflect important aspects of Bamana social organization. Bogolan tunics are worn by hunters, a highly respected and powerful group for whom bogolan’s earth tones serve as camouflage, ritual protection, as well as an immediately recognizable emblem of their occupation. The cloth is also present at important events in a woman’s life. Bogolan wrappers are worn by girls following their initiation into adulthood, a process which includes female circumcision, and by women immediately following childbirth. The cloth is believed to have the power to absorb the dangerous forces released at these significant moments.

### Making Bogolan

Bogolan cloth is woven on narrow looms by men to create long strips of cotton fabric approximately six inches wide, which are stitched together to create wrapper-sized cloths (approximately a yard by five feet [1 by 1.5 m]). Production of dyes and decoration of the cloths is the work of women, who develop their skills over years of apprenticeship to their elders. The first and most essential step in the dyeing process is, paradoxically, invisible in the final product. Leaves from a tree called *n'gallama* are mashed and boiled or soaked to create a dye bath. After immersion in the dye bath, the now-yellow cloth is dried in the sun. Using a piece of metal or a stick, women paint designs in special mud that has been collected from riverbeds and fermented in clay jars for up to a year. A chemical reaction occurs between the mud and the *n'gallama*-dyed cloth, so that after the mud is washed off, the black or brown design remains. The yellow tone of the *n'gallama* dye is then removed from the unpainted portions of the cloth: the undecorated parts of the fabric are treated with soap or bleach, restoring the white of the undyed cotton.

The patterns that adorn the cloth are created by applying the dark mud *around* the motifs. This work is very difficult; every line, dot, and circle must be carefully outlined not once but several times in order to create a deep, rich color. The designs that adorn bogolan often carry a great deal of cultural significance. The symbols may refer to inanimate objects, to historical events, to mythological subjects, or to proverbs. One popular pattern refers to a famous nineteenth-century battle between a Malian warrior and the French colonial forces. Other patterns depict crocodiles, a significant animal in Bamana mythology, and talking drums used to spur Bamana warriors into battle. Artists may select from a wide variety of motifs, which they employ in various combinations to produce a single piece of cloth.

### Bogolan as a Contemporary Symbol

Over the course of the past two decades, bogolan has become a symbol of Malian identity, appearing at government-sponsored events and in official publications. Outside Mali, bogolan is made into a variety of products that represent Mali or, more broadly, Africa. The cloth is particularly well suited to serve as a symbol; in addition to being uniquely Malian, bogolan's bold colors and patterns are readily recognizable. In addition, its important uses in traditional contexts appeal to Malian national pride and to foreigners interested in Malian culture. Today, the cloth is familiar to nearly all Malians; it is made and worn by people of all ethnicities and ages. In Mali, bogolan is associated with local cultures, part of the heritage of the artists who make it and the merchants who sell it. In the United States, where bogolan is also popular, the cloth is foreign, exotic. While in some contexts bogolan is marketed as a symbol of African American culture, in others the cloth is presented as vaguely "ethnic."



### BOGOLAN AND FASHION

*Bogolan* clothing, worn by Malians and non-Malians alike, is a common sight in urban streets, classrooms, and nightclubs. The cloth is prominent in Malian cinema and it is often worn by the country's musicians, many of whom tour internationally. Bogolan is used to make clothing in a wide range of styles, from miniskirts and fitted jackets to flowing robes in traditional styles. The designer Chris Seydou is credited with adapting the cloth to fashion in international styles, cultivating interest in this indigenous art form both in Mali and abroad. For some who wear it, bogolan clothing is an expression of national or ethnic identity. For others, the cloth is simply chic, a fashion statement rather than a political stance. Bogolan clothing is particularly popular among young people, who are often in the forefront of shifting fashions.

See also **Textiles, African; Traditional Dress.**

#### BIBLIOGRAPHY

- ADEIAO. *Bogolan et Arts Graphiques du Mali*. Paris: ADEIAO et Musée des Arts Africains et Océaniens, 1990. An introduction to the work of a cooperative group of artists who have adapted bogolan to contemporary studio art.
- Aherne, Tavy. *Nakunte Diarra: A Bógólanfini Artist of the Beledougou*. Bloomington: Indiana University Art Museum, 1992. A small but excellent exhibition catalog on the work of an important rural bogolan artist.
- Brett-Smith, Sarah. "Symbolic Blood: Cloth for Excised Women." *RES* 3 (Spring 1982): 15–31. An analysis of the role of bogolan in women's initiations.
- Imperato, Pascal James, and Marli Shamir. "Bokolanfini: Mud Cloth of the Bamana of Mali." *African Arts* 3, no. 4 (Summer 1970): 32–41, 80. An excellent and well-illustrated overview of bogolan in the Bamana heartland.
- Rovine, Victoria L. *Bogolan: Shaping Culture Through Cloth in Contemporary Mali*. Washington, D.C.: Smithsonian Institution Press, 2001. An exploration of bogolan's many contemporary forms and meanings in rural and urban Mali, as well as the cloth's international manifestations.

Victoria L. Rovine

**BOHEMIAN DRESS** "Bohemian" was the label attached to artists, writers, students, and intellectuals in early nineteenth-century France after the turbulent years of the Revolution. The reason for the name was that these artists were likened to wandering gypsies, and it was be-



**Greenwich Village café.** The Gaslight coffee house in New York's Greenwich Village in the late 1950s, and others like it, provided the setting for the Bohemian movement throughout the years. Artists, writers and students used their dress to illustrate both their poverty and their originality. © BETTMANN/CORBIS. REPRODUCED BY PERMISSION.

lied (incorrectly) that gypsies came from Bohemia in central Europe. With rapid economic and social change, the artist's status became financially insecure as the market replaced the old system of patronage. At the same time the Romantic Movement introduced the seductive notion of the "Artist as Genius." An artist was no longer someone with a particular talent, but became a special kind of person. In earlier times dress had signified social status, a trade, membership of a princely retinue, or a profession. Now for the first time, dress became part of the performance of an individual personality, as the young bohemians used costume to signify their poverty and originality.

There was no single chronological line of development in bohemian dress; rather, there were several different strategies. In the 1830s the styles of dress favored by French bohemians had echoes of the Romantics' love of the medieval and of orientalism. Influenced by the fevered poetry of Byron, they favored rich materials and colors, wide-brimmed hats, and long flowing curls.

A second style, described by the novelist Henri Murger (1822–1861), whose bohemian tales are best-known today as the basis for Giacomo Puccini's opera, *La Bohème*, was simply the uniform of abject poverty, threadbare coats and trousers, leaking shoes, and general dishevelment. A third influential style was the restrained



black and white of the male dandy. Dandyism originated in Regency England and, although distinct from bohemian dress, was influential in that dandies, such as George Bryan “Beau” Brummell (1778–1840), developed a cult of the self. They went to such lengths that their appearances became almost works of art in their own right, blurring the dividing line between life and art. This was significant for the bohemian way of life, since for many bohemians this line was blurred in any case, and style, surroundings, and dress became as stylized and carefully wrought as any more conventional artwork.

Then there were those who were influenced by the nineteenth-century movements for dress reform. Dress reformers advocated an end to the distortions and restrictions of fashion, especially women’s fashions, and searched for a permanently beautiful form of clothing that would put an end to the fashion cycle. The English Pre-Raphaelites were the best known such group. One of their members, William Morris (1834–1896), who built a successful business on the design and sale of alternative textiles, wallpapers, and embroidery, designed robes for his wife, Jane, that were far removed from the crinolines and corsets of the mid-Victorian period. These innovators were part of the Arts and Crafts movement that spread throughout Europe during the second half of the nineteenth century and by the 1890s had reached Germany, where the styles were combined with art nouveau motifs. The painter Vasily Kandinsky (1866–1944), for example, designed dresses for his lover, the artist Gabriele Muntter (1877–1962), which had the natural Pre-Raphaelite line, with full sleeves and loose waists for ease of movement.

Kandinsky and Muntter belonged to the artistic and bohemian culture that flourished in and around Munich during this time, where bohemianism was taken to extremes seldom seen before or since. Some of these eccentrics and revolutionaries expressed themselves by adopting what amounted to fancy dress, in imitation of ancient Greece and Rome, or sometimes borrowing from peasant culture.

Bohemian dress, like the whole bohemian counterculture, underwent many vicissitudes during the course of the twentieth century. Between World War I and II, bohemianism became for many young people little more than a phase during which they would dress in a picturesquely rebellious manner, live in artists’ studios, and go to bohemian parties—a way of life not so different from that of students in the twenty-first century. The link between genuine creativity and a style of life became attenuated. The idea of “lifestyle” was developing, even if the word did not come into use until after World War II. Yet the idea of bohemia as a privileged and special place—or even just an idea—remained as a kind of umbrella concept beneath which society’s dissidents, geniuses, misfits, and eccentrics still gathered to encourage and support one another. For example, lesbians in the

1930s often regarded themselves as bohemians rather than as belonging to a distinct “lesbian subculture.”

After 1945 this changed. Bohemia had always effectively been a land of youth, but it was only with the development of the mass media and popular music that the existence and costuming of the generational divide became explicit. Jazz, swing, and rock and roll came with their own uniforms of rebellion. Then came beatniks with, for young women, white lips, black kohl-ringed eyes, peasant skirts, black stockings, and “arty” jewelry—but now for the first time such styles were quickly broadcast via the mass media to a much wider circle of bohemian wanna-bes. The 1957 Audrey Hepburn film, *Funny Face*, for example, satirized Greenwich Village style—at the beginning of the film the star is shown working in a bookshop, dressed in a tweed jumper, black turtleneck sweater, horn-rimmed-glasses, and flat ballerina shoes.

Artists and writers that were displaced as minority groups took center stage in the creation of countercultural dress. Alongside the huge influence of black American style, beginning with the zoot suit of the 1940s, the emergent lesbian and gay culture began to make an impact. Although the most familiar form of alternative dress in the 1960s and 1970s was the hippie style, which boasted bricolage, secondhand clothes, and ethnic items to create a statement about an alternative lifestyle opposed to the consumer society.

Yet at the dawn of the third millennium, it hardly seems as if rebellion can any longer be expressed in the wearing of outrageous garments. Bohemian dress was always a provocation, but in Western, or westernized urban settings, at least, there hardly exists a style of dress that can shock anymore. Grunge, and the styles of Nirvana in the early 1990s, was the last form of dress that aimed to express dissent of the traditional kind. But, like every style, it was no sooner seen on stage than it appeared in every mass-market fashion store in the Western world.

Some have suggested that rebellion of the old bohemian sort is no longer possible, since there no longer exists a single mainstream or dominant form of society against which to rebel. Instead we have what one French sociologist terms “neo-tribes,”—groups with fluid membership of young people who are no longer confrontational, but have an allegiance to certain styles of music, dress, and clubbing. There are exceptions: Goth style and the accoutrements of the anti-globalization movement single out participants fairly definitively. Yet what was once the casual originality of bohemian dress has become the height of celebrity fashion and of high-street style. It therefore follows that in the twenty-first century, when everyone is bohemian, no one can any longer be.

See also **Brummell, George (Beau); Subcultures.**

## BIBLIOGRAPHY

- Beard, Rick, and Leslie Cohen Berlowitz, eds. *Greenwich Village: Culture and Counter Culture*. Camden, N.J.: Rutgers University Press, 1993.
- David, Hugh. *The Fitzrovia: A Portrait of Bohemian Society, 1900–1955*. London: Michael Joseph, 1988.
- Siegel, Jerrold. *Bohemian Paris: Culture, Politics and the Boundaries of Bourgeois Life, 1830–1890*. New York: Viking Press, 1986.
- Wilson, Elizabeth. *Bobemians: The Glamorous Outcasts*. Camden, N.J.: Rutgers University Press, 2001.

Elizabeth Wilson

**BOOTS** The modern definition of the term “boots” is a loose one; footwear covering the entire foot and lower leg. This is believed to have developed from one of the earliest forms of footwear—a two-piece unit covering the foot and lower leg. This wrapping of the leg formed the building block on which all modern forms of the boot have derived.

Throughout history the essential form of the boot has been adapted to fit the needs of the wearer and the culture. Materials vary as does form—but the essential purpose of the boot remains the same throughout most cultures; to provide protection from the elements. Boots are usually made of leather, but have been made of many other materials, including silk, cotton, wool, felt, and furs. A perfect example of this is the *kamiks* of the Inuits. The Inuits pride themselves on their efficient use of their resources and their traditional boots, called *kamiks*, are no exception. Crafted of caribou hide or sealskin (their two main food sources), these boots are warm and waterproof thanks to an ingenious raised band of stitching with sinews that ensures a waterproof join at the sole and upper.

The oldest known depiction of boots is in a cave painting from Spain, which has been dated between 12,000 and 15,000 B.C.E. This painting seems to depict man in boots of skin and a woman in boots of fur. Persian funerary jars have been found which date from around 3000 B.C.E. and are made in the shape of boots. Boots were also found in the tomb of Khnumhotep (2140–1785 B.C.E.) in Egypt. The Scythians of about 1000 B.C.E. were reported by the Greeks to have worn simple boots of untanned leather with the fur turned in against the leg. These simple baglike boots were then lashed to the leg by a thong of leather. This basic form can be found in the traditional dress of many Asiatic and Arctic cultures as well.

In the ancient world, boots represented ruling power and military might. Emperors and kings wore ornate and colorful examples; this was a significant distinction when the majority of the population went barefoot. Leather was expensive, and roman emperors were cited as wearing colorful jeweled and embroidered examples—even with gold soles. Boots were also already associated with the



**Frank and Nancy Sinatra, 1966.** Nancy Sinatra's song *These Boots Are Made for Walking* came at a time when the footwear was enjoying particular popularity. © BETTMANN/CORBIS. REPRODUCED BY PERMISSION.

military—the *campagnus* was worn by the highest-ranking officers and some senators in ancient Rome, the height of the boot denoting rank. Other styles, such as the high, white leather *phaecasin*, were worn as ceremonial garb.

During the Middle Ages, the styles shoes and boots established by the ancient world continued. Courtiers of the Carolingian period were depicted wearing high boots laced halfway up the leg. Under Charlemagne the term *brodequin* is first used for these laced boots and roman terms rejected. The *buese*, a high, soft leather shoe and forerunner to the boot appeared toward the ninth century. During the twelfth through fourteenth centuries, a short, soft boot called the *estivaux* was popular. Toward the middle of the fourteenth century, people often wore soled hose, which precluded the need for shoes and boots.

In the fifteenth century, men wore long boots that reached the thighs and were usually of brown leather. This style was prevalent among all of the classes. Despite this widespread popularity, this was emphatically not an appropriate style for women; in fact this was one of the chief criminal charges against Joan of Arc in 1431. It was more common for women of the fourteenth century to wear laced ankle boots, which were often lined in fur.

By the sixteenth century, high boots of soft perfumed leather were worn to meet upper stocks and would soon

develop into the wide, floppy cavalier styles of the first half of the seventeenth century. Soft boots folded down—and slouchy boots worn with boot hose elaborately trimmed with lace flaring out into wide funnel shapes to fold down over the boots—characterized these fashions. Boot hose was worn both for its decorative qualities and to protect the costly silk stockings. These high boots featured a leather strap on the instep (the *surpiéd*), and a strap under the foot, which anchored the spur in place (the *soulette*). They had funnel tops, which covered the knee for riding and could be turned down for town wear. Under Louis XIII a shorter, lighter model of boot emerged, the *ladrine* (Boucher, p. 266). In the early years of the eighteenth century, under the influence of the French court, boots disappeared except for those worn by laborers, soldiers, and devotees of active sports, such as hunting and riding.

The seventeenth century had seen the emergence of the first military uniforms, and the boot had played an essential role in this standardization. The high-legged cavalier boot of the previous century was transformed by a highly polished and rigid leg—the prototypical military jackboot. The high top and rigid finish was supremely practical and successful at protecting legs while on horseback. This style was seen as early as 1688 and continued to be worn into the 1760s. Other popular styles were essentially military in origin. One notable example was the Hessian or Souvaroff, which was brought to England by German soldiers circa 1776. This style featured a trademark center front dip and was trimmed with tassels and braid.

For the more gentlemanly pursuit of sport riding, the high cavalier boot of the seventeenth century developed into a softer and closer fitting “jockey” style boot with the top folded down under the knee for mobility which showed the brown leather or cotton lining. This style originated in 1727 and became increasingly fashionable into the 1770s. The popularity of the English style riding boot was a part of the greater Anglomania of the eighteenth century and foreshadows the “Great Masculine Renunciation” that would follow in the wake of the French Revolution and the early years of the nineteenth century.

The vogue for democratic, English style dress had made the boot more popular than ever. Beau Brummel epitomized the radical simplicity of the dandy. His typical morning dress was reported as “Hessians and pantaloons or top boots and buckskins” (Swann, p. 35). Despite this endorsement, the shape and design of the boot inevitably shifted with fashion. The Wellington supplanted the Hessian since the tassels and braid of the Hessian were difficult to wear with the newly fashionable trousers. The Wellington boot was essentially a Hessian that had had its curved top cut straight across with a simple binding. This style was reputedly developed by the Duke of Wellington in 1817 and dominated menswear in the first quarter of the nineteenth century. The success of the Wellington was

so pronounced that it was said in 1830, “the Hessian is a boot only worn with tight pantaloons. The top boot is almost entirely a sporting fashion...although they are worn by gentlemen in hunting, they are in general use among the lower orders, such as jockeys, grooms, and butlers. The Wellington...the only boot in general wear” (*The Whole Art of Dress* as quoted in Swann, p. 43).

The Blucher was another important style of the early nineteenth century named for a popular war hero. The Blucher was a practical, front-laced ankle boot worn by laborers in the eighteenth century, which had popularly been known as the “high-low.” After 1817 this style was known as the Blucher and was worn for casual and sport wear. This basic laced-front style would prove to be popular in modified forms to this day, and has served as the basis of the modern high-top sneaker, hiking boot, and combat boot.

The popularity of boots began to influence women’s fashions during the early years of the nineteenth century. Women had been wearing masculine-style boots for riding and driving during the eighteenth century, and by the 1790s their styles had become distinctly feminine with tight lacing, high heels, and pointed toes. By 1815 fashion periodicals begin to suggest boots for walking and daywear; boots were widespread by 1830. The most common style was the Adelaide, a flat, heelless ankle boot with side lacing. This style would remain in use for more than fifty years.

During the Victorian period boots of all kinds reached the peak of their popularity. The trend was for greater comfort and practicality in footwear for both men and women and was aided by technological advances like the sewing machine and vulcanized rubber. In 1837 the British inventor J. Sparkes Hall presented Queen Victoria with the first pair of boots with an elasticized side boot gusset. This easy to wear slip on style would be popular throughout the rest of the century with both men and women. By mid-century the two most popular styles were the elastic side—also known as the congress, side-spring, Chelsea, or garibaldi—and the front-lacing boot. The two most popular styles for front lace were the Derby and the Balmoral. The latter boot was designed for Prince Albert and was similar in style to the modern wrestling or boxing shoe. By the late Victorian period, balmorals or “bals” were most popular and frequently featured contrasting cloth tops and pearl button closures.

Although the Wellington had been almost entirely abandoned in England in favor of the short ankle boot by the 1860s, the style survived in United States and contributed to the development of the cowboy boot. The cowboy boot is believed to have originated in Kansas, and is considered to be a combination of the Wellington and the high heeled boots of the Mexican *vaqueros*. In the United States the Hessian continued to be worn as well and can be seen in photographs of the outlaw “Billy the Kid” from the 1870s.



For women in the mid-century, the majority of footwear was in boot form. The elastic side was a popular choice for daywear, but by the 1860s was replaced by front lace balmorals in satin or colored leather for dressy occasions. Tightly laced boots gave the impression of modesty but also accentuated the curves of the ankle and calf. Increasingly boot styles emphasized this aspect. By 1870 the principal styles worn were side springs, balmorals, and high-button boots. A new development was the barrette boot, which can be viewed as an extension of the shoe since so much of the stocking could be seen through the delicate straps.

In the early years of the twentieth century, boots were still prevalent but soon abandoned by fashionable dress in the 1920s. In this period boots returned to their functional role, and traditional forms remained in use for specific military and sport activities. The exception to this was the vogue among women for knee-high leather Russian boots which featured relatively high heels and a side zipper for a close fit. In the second half of the twentieth century, boots reemerged as an important element in the counterculture fashions favored by the young. Early rebels adopted the sturdy Engineer or Motorcycle boot as a visible sign of their rebellion inspired by films such as *The Wild One* and *Rebel Without a Cause*. In the late 1950s a trend developed for elastic side boots copied from the nineteenth-century originals, but with the addition of a high heel and a pointed toe which were worn with the new slim-fitting tapered trouser. These were the Chelsea boots and would later become known as "Beatle boots."

Women saw an explosion of fashion boots after 1960. While the flat-heeled, white kid leather boots launched by Parisian couturier André Courrèges was the ubiquitous boot of the decade, many styles of boot were popular. Go-Go boots could be ankle, knee, or thigh high and with or without heels, they all served as the perfect accompaniment to the miniskirt. By the end of the decade, retro styles became popular, and the front lacing granny boot became an essential part of the hippie style.

Styles were increasingly unisex in the 1970s, with both genders wearing suede chukka boots, cowboy boots, and high zip-up platform boots. The Dr. Martens boot, originally designed as an orthopedic shoe in the 1940s, was adopted by the punk counter-culture in the 1970s, but by the 1990s had been assimilated into popular fashion. Masculine-styled boots worn by women have been considered extremely provocative, especially when paired with more conventional symbols of femininity.

While traditional forms of boots continue to be worn throughout the world for specific functions, they have also played an important role in fashion throughout history.

See also **Inuit and Arctic Footwear; Sandals; Shoes.**

#### BIBLIOGRAPHY

Cunnington, C. Willett. *English Women's Clothing in the Nineteenth Century*. New York: Dover Publications, Inc., 1990.

McDowell, Colin. *Shoes: Fashion and Fantasy*. New York: Thames and Hudson, 1989.

Pratt, Lucy, and Linda Woolley. *Shoes*. London: V & A Publications, 1999.

Swann, Julie. *Shoes*. London: Butler and Tanner Ltd., 1982.

Wilcox, R. Turner. *The Mode in Footwear*. New York: Charles Scribner's Sons, 1948.

Clare Sauro

**BOUBOU** The boubou is the classic Senegalese robe, worn by both men and women all over West Africa and in West African diasporic communities of Europe and the United States. Sewn from a single piece of fabric, the boubou is usually 59 inches (150 cm) wide and of varying lengths. The most elegant style, the *grand boubou*, usually employs a piece of fabric 117 inches (300 cm) long and reaches to the ankles. Traditionally, custom-made in workshops by tailors, the boubou is made by folding the fabric in half, fashioning a neck opening, and sewing the sides halfway up to make flowing sleeves. For women the neck is large and rounded; for men it forms a long V-shape, usually with a large five-sided pocket cutting off the tip of the "V."

When stiffly starched and draped over the body, the boubou creates for its wearer the appearance of a stately, elegant carriage with majestic height and presence. Men wear the classic boubou with a matching shirt and trousers underneath. Women wear it with a matching wrapper or *pagne* and head-tie.

#### Fabric, Embroidery, and Dyeing

Tailors who specialize in making boubous invest their skills in the art of embroidery. The fabric for these embroidered boubous is cotton damask, called *basin* in the francophone West African countries. Although the fabric can be bought in colors, connoisseurs prefer to buy white cloth and have it hand dyed in rich hues by women dyers working out of their homes. Available in market stalls in several grades of quality, the damask at its most expensive comes from Europe, while cheaper imitations come from Asia or Nigeria.

After the fabric is dyed, the tailor creates the embroidery design with a small sewing machine, either electric or pedal driven. Traditionally, the embroidery was white or beige, but in the 1970s, tailors in Dakar, Senegal, introduced colored embroidery, and in the early 2000s they vie with each other to create intricate, multi-colored designs in vibrant hues for women. Men continue to wear white or beige embroidery, or else use threads the same color as the damask, often dyed deep purple or green. The exception for men is a white voluminous boubou with gold embroidery. This is the special costume of *El Hage*, the Muslim who has made the pilgrimage to Mecca. It thus connotes wealth, prestige,

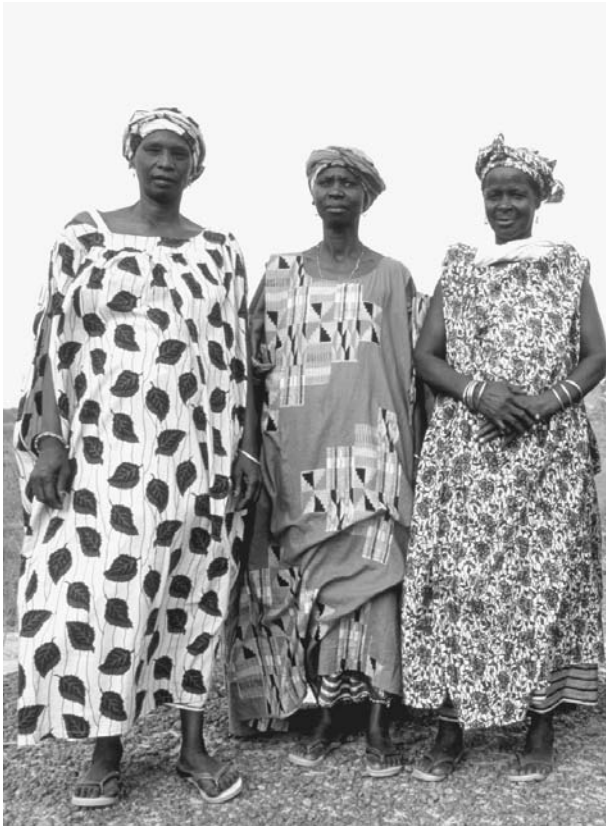

**Senegalese women wear the Senegalese robe, or boubou.** The garment is sewn from a single piece of embroidered cotton damask fabric. The boubou is the most basic garment in the Senegalese culture, much like blue jeans in the United States.

© PRAT/CORBIS SYGMA. REPRODUCED BY PERMISSION.

and piety. As with the fabric, the high prestige embroidery threads are silk and come from France. Polyester imitations are imported from Asia.

Non-embroidered fabrications include *basin* resist-dyed in striking designs. For stitch-resist or tie-dyes, designs can be large enough to use one motif for the whole boubou, or small enough to demand thousands of tiny stitches in a fine repeated motif. It takes a group of women three months to sew the stitches before dyeing and three months to cut them out with a razor afterward. Techniques also include starch resist or wax resist. One technique, called *indigo palmann*, uses indigo in such a way as to dye the fabric a rich, deep bronze hue. Although a solid color, the *indigo palmann* boubou is so resplendent in its simplicity that it forgoes embroidery. For less elegant occasions, women have boubous made of Holland wax print or of imitation wax print called *légos*.

### Historical and Geographical Changes

The word “boubou” comes from the Wolof *mbubbe*. (Wolof is the principal African language of Senegal.) This linguistic origin suggests that in contrast to borrowed

dress styles, like the Arab caftan and the European suit, the boubou, as Senegalese people say, has always been Senegalese. In Anglophone West African countries, the cognate, *buba*, has a somewhat different meaning. Especially in Nigeria and Ghana, the *buba* is a hip-length shirt, with sleeves made of separate pieces of fabric and sewn to the body. It is worn under the long boubou, which in these countries is called the *Agbada*. The men’s *buba* is also worn alone with matching trousers called *sokoto*. Women wear the *buba* with a wrapper.

This linguistic link suggests the historical changes in style that the boubou has undergone. In the nineteenth century, the Senegalese boubou, made of bulky, handwoven strip cloth, was often as short as the modern Nigerian *buba*, although without the sleeves (see P. David Boilat’s sketches in Boilat 1853). In the course of the nineteenth century, the expanded use of imported factory-woven cloth and the expansion of Islam combined to bring into fashion for Muslim men the longer, more voluminous *grand boubou*, which resembled an Arab caftan. By the early twentieth century, as urban Christian men started wearing suits, and urban middle-class men had to wear suits for work, Muslim men adopted the *grand boubou* for leisure and for ceremonial or religious occasions. Peasant and working-class women wore a *grand boubou* of plain, imported factory-woven cloth. But wealthier urban Muslim women wore a hip-length boubou that showed off their *pagnes* (wrappers) of rich hand-woven strip cloth or fine imported French fabric. Young Christian women adopted a loose, high-waisted dress, called *boubou à la française* (in Wolof *ndoket*).

The elegant *grand boubou* for women did not come into fashion until after World War II. By the end of the twentieth century, young women would sometimes adopt a hip- or knee-length boubou as a fashion alternative and for more casual wear. The *boubou à la française* also returned as a high-fashion item, newly named the *mame boye* (Wolof for “darling grandmother”).

### Cultural Meanings

As the centerpiece of classic dress in Senegal and neighboring Francophone countries, the boubou occupies the symbolic position of the most basic garment in other cultures, comparable in this respect to blue jeans in American culture. Like blue jeans, the Senegalese *grand boubou* accrues to itself a multiplicity of contradictory uses and meanings. It can connote sexiness or modesty. It can attain the height of elegance or serve a utilitarian purpose. A stiffly starched, embroidered boubou, falling alluringly off one shoulder and perfumed with incense, can be worn with high heels, gold jewelry, a starched matching head scarf tied in a rakish knot, and dramatic makeup. This is the outfit young women wear for weddings, baby-naming ceremonies, and Muslim feast days. This is also the outfit of the *Dirriankhe*, a woman who fulfills the Senegalese ideal of seductive beauty. She is large, sensuous, and conveys the mystique

of independence and wealth. She has mastered the art of wearing the boubou. Yet the boubou is also the obligatory dress of respectable Muslim matrons, considered too old and too modest to wear the form-fitting trousers and leg-baring skirts sported by slender young women. For Muslim men, an embroidered, damask boubou can be the height of elegant prestige, but it is also the dress required for praying at the mosque.

See also **Africa, North; History of Dress; Africa, Sub-Saharan; History of Dress; Pagne and Wrapper.**

#### BIBLIOGRAPHY

- Bastian, Misty. "Female 'Alhajis'" and Entrepreneurial Fashions: Flexible Identities in Southeastern Nigerian Clothing Practice." In *Clothing and Difference: Embodied Identities in Colonial and Post-Colonial Africa*. Edited by Hildi Hendrickson. Durham, N.C.: Duke University Press, 1996.
- Boilat, P. David. *Esquisses sénégalaises; physionomie du pays, peuplades, commerce, religions, passé et avenir, récits et légendes*. Paris: P. Bertrand, 1853.
- Eicher, Joanne Bubolz. *Nigerian Handcrafted Textiles*. Ile-Ife, Nigeria: University of Ife Press, 1976.
- Heath, Deborah. "Fashion, Anti-fashion, and Heteroglossia in Urban Senegal." *American Ethnologist* 19, no. 2 (1992): 19–33.
- Mustafa, Huda Nura. "Sartorial Ecumenes: African Styles in a Social and Economic Context." In *The Art of African Fashion*. Edited by Els van der Plas and Marlous Willemsen. Eritrea: Africa World Press, 1998.
- Perani, Judith, and Norma H. Wolff. *Cloth, Dress and Art Patronage in Africa*. New York: Berg, 1999.
- Picton, John, Rayda Becker, et al. *The Art of African Textiles: Technology, Tradition, and Lurex*. London: Barbican Art Gallery; Lund Humphries Publishers, 1995.
- Rabine, Leslie W. "Dressing up in Dakar." *L'Esprit créateur* 37, no. 1 (1997): 84–107.
- . *The Global Circulation of African Fashion*. Oxford: Berg, 2002.

Leslie W. Rabine

**BOURDIN, GUY** Guy Bourdin (1928–1991) has an extraordinary cult following within the field of fashion photography, expanded by the 2003 retrospective of his work at London's Victoria and Albert Museum. Critical, autocratic, dictatorial, and quirky, he had a personal life that was chaotic and probably sadistic, pushed his models to the point of tears and passing out, and even undermined his reputation during his lifetime and his legacy upon his death. Yet despite—or possibly because of—the morbidity and violence of his personal and professional life, Bourdin has had a profound influence on photographic and artistic currents of the late twentieth century.

#### Bourdin's Background

Guy Bourdin was born in Paris. His mother abandoned him when he was still an infant, and he was alternately

raised by his grandparents in Normandy and Paris and placed in a boarding school. Bourdin was the only child to the age of fifteen, when his brother, Michael, was born, and he spent much time in the solitary pursuits of reading and drawing.

At age twenty Bourdin joined the French air force for his mandatory two years of military service, working as an aerial photographer in Dakar, Senegal. After he completed his service, he wanted to buy a small wedding photography business in Magny-en-Vexin, near the family home in Normandy. Refused a loan by his father, Bourdin worked at Bon Marché, the Paris department store, selling lenses and at a variety of odd jobs, including cleaning floors, acting as a messenger at the U.S. Embassy, and washing dishes at the Brasserie Lipp. During this period, he continued to draw, photograph, and produce paintings inspired by Balthus, Francis Bacon, and Stanley Spencer.

In the late 1940s Edward Weston's photograph of a pepper showed Bourdin that photography could be art. He was also inspired by the monumental landscapes of Ansel Adams and developed a friendship with the dada painter and photographer Man Ray, who wrote the gallery announcement for Bourdin's 1952 exhibition at Galerie 29 on the rue de Seine in Paris. It was undoubtedly through Man Ray that Bourdin became acquainted with surrealism, which was to infuse his photography throughout his life.

#### Bourdin's Editorial and Advertising Photography

In 1954 Bourdin took his work to French *Vogue*, where he was given a fashion assignment on hats. It included a shot, which has become one of Bourdin's early classics, showing a model walking by a butcher shop, three skinned and bloodied calves' heads swinging just above her impeccably turned head. Bourdin continued his exclusive editorial work for French *Vogue* from 1955 through 1987. Bourdin's advertising work for Charles Jourdan shoes from 1967 to 1981 was extremely important. He also did advertising work for the designer Grès and in 1976 photographed the controversial Bloomingdale's "Sighs and Whispers" lingerie brochure, which has become a collector's item.

The Charles Jourdan shoe campaign was groundbreaking in its approach, originality, and daring. In Bourdin's hands, the shoe was presented as a fetishistic object, both as an object of desire and the focal point of scenarios of violence. Bourdin's infamous 1975 photograph depicting the scene of a bloody automobile fatality, the body marked in chalk on the pavement next to the featured shoes, was a benchmark in the history of attraction by shock. The power and perversity of this image were legendary: that an image of death and tragedy (though fictitious) would be used to sell shoes was unthinkable, yet unforgettable. The image itself possessed the same power of attraction that causes a crowd to gather at the scene



of a gory accident. In other shots Bourdin juxtaposed gigantic shoes and tiny shoes, which had been made especially for this purpose by the Jourdan company. In this way, Bourdin played on the type of size discrepancies often used in surrealist works, such as the paintings of René Magritte.

### Background of Bourdin's Style

Bourdin clearly transformed his personal obsessions into a body of work that was stunningly daring and visually unforgettable. "What Guy did," his stylist Serge Lutens has said, "was conduct his own psychoanalysis in *Vogue*" (Hayden-Guest, p. 143). Abandoned as an infant by an unloving woman, he obsessively depicted women tied up, in compromising situations, or dead. He was said to favor models with pale red hair, because they reminded him of his mother, and he was renowned for making bizarre, macabre, and sometimes cruel demands on them. Stories abound about models being made to balance on a rock during an electrical storm, being subjected to props that cut into their flesh, and passing out after being suspended to appear as if they were flying.

One model, Louise Despointes, was said to have been kept waiting in a freezing studio, then wrapped in plastic and lowered into a bathtub of extremely cold water on which black enamel paint had been floated. She emerged from the tub "enameled" in black paint, uncomfortable and unable to work for days. Bourdin even reputedly placed models in life-threatening positions and delighted in the idea of their deaths. In another famous story, Bourdin initially smeared the faces of Despointes and another model with a thin layer of glue as a way to stick dozens of pearls to their faces. When he decided to cover their entire bodies with pearls, they passed out because they were not getting enough oxygen to their skin and could not breathe, and the editor stopped the shoot, thinking the models would die. Bourdin was reputed to have said, "Oh, it would be beautiful—to have them dead in bed!" (Hayden-Guest, p. 136).

### Eroticism and Violence in Bourdin's Photography

Eroticism—and the link between sex and violence—is a major component of Bourdin's photography. The foundation had been laid by the imagery of the preceding decade, particularly the sexual emancipation of Richard Avedon's work of the 1960s. Yet the brilliant and sensitive use of nudity and sexual innuendo that Avedon and Bob Richardson had introduced into fashion depiction in those years—confronting lesbianism and the ménage à trois, for instance—was tame by 1970s' standards. The time was ripe for Bourdin's stylized violence and the darker realities of voyeurism, death, and rape.

Bourdin's photographic violence is thematically akin to the bloody climax of the film *Bonnie and Clyde*, the dental torture in *Marathon Man*, or the orgiastic violence of *The Wild Bunch*. This brand of violent depiction plays with

the audience's attraction to the escalating brutality and demands that the viewer consider violence glamorous. The new brand of violent fashion photography and film supplies the viewer with a fantasy fulfillment unavailable in everyday life. As Stephen Farber explains in his *New Yorker* article "The Bloody Movies: Why Film Violence Sells":

One of the functions of popular art has always been to give people some notion of experiences denied them in reality—a taste of romance, glamour, adventure, danger. But perhaps as everyday life becomes more smoothly homogenized, people need splashier, more grotesque vicarious thrills. Today, . . . [we only experience violence] at professional hockey and football games, at high-powered rock concerts, or at the movies. (p. 44)

Or, one might add, in fashion photography.

Guy Bourdin's violence against women—both actual and photographic—played on their vulnerability, which is a leitmotif in his work. Shadows are an effective device often used for creating an air of mystery, implied physical threat, and even frenzy. Bourdin used such shadows as early as 1966 to suggest the presence of Batman—normally a hero figure and protector—chasing a confused, worried woman through the streets. The thrown shadows, used repeatedly in Bourdin's oeuvre, represent the woman's living nightmare of vulnerability, of being threatened by indistinguishable forms and unseen presences.

### Influence of Bourdin's Personal Life on His Work

Bourdin even materialized the reality of violence toward women into his personal life: his first wife is thought to have committed suicide, his second hanged herself, one girlfriend lived after slashing her wrists, and another died after falling out of a tree. As Tim Blanks suggested in his *New York Times Magazine* article, "Both masochism and sadism were bedfellows." Bourdin also seemed bent on undermining himself and his own reputation. He was infamous for not allowing his work to be used in books and exhibitions and for refusing to grant interviews. In 1985 he rejected the \$9,000 Grand prix national de la photographie, given by the French Ministry of Culture.

In his article "The Return of Guy Bourdin," Anthony Hayden-Guest explained how Bourdin, when he died of cancer at age sixty-two, left his estate in disarray, compounding a horrendous tax situation and further paralyzing his legacy (p. 137). He had deeded his pictures to Martine Victoire, his common-law wife of seven years, in a signed and witnessed (but not notarized) contract; Samuel Bourdin, the photographer's estranged only child, contested the action. The legal decision gave Victoire possession of the archives but allowed Samuel to exercise his discretion in their use. Without his consent, Victoire could not publish, sell, or exhibit the photographs she owned. Subsequently, the reproduction rights were contested in court.

### Bourdin's Influence

The vast influence Bourdin had on subsequent art and photography is only now becoming clear. Like it or not, Bourdin broke taboos and reflected the escalating violence in society, blazing the path for contemporary artists like Paul McCarthy and Matthew Barney in combining the disgusting with the exalted. He pioneered the narrative approach to photography that has become one of its dominant strains, from the work of Gregory Crewdson to that of David LaChapelle. Bourdin created pictures filled with what seemed to be clues in a mystery, hinting at meanings rather than articulating them. We are often unsure of what is going on; we know only that we are dealing with a specific moment in which something has happened or is about to happen. Bourdin scatters clues in his pictures, such as water spurting from a pool with a shoe by its edge, a girl "talking" to a shark, or two girls dressed only in lingerie watching as items fall from a purse, frozen in midair.

Bourdin was also one of only a handful of photographers who had almost complete creative freedom within the field of editorial and advertising fashion photography. In both realms Bourdin was a technical virtuoso. His brilliance in producing a wide range of ideas with a continually fresh vision was equaled by his mastery of technique and execution. His background as a painter influenced his approach, particularly the way he built his compositions. Each shape and color was painstakingly and thoughtfully composed to contribute to the whole.

Bourdin's concern for the final effect of his work, including the exact placement on the printed page, is evidence of his commitment to fashion photography. With respect to the photograph itself as a compositional element, he created some of the most unusual and visually exciting layouts ever published in fashion periodicals. Particularly effective was his frequent grouping of photographs in multiples or sequences, repeating sections of the picture or making unexpected juxtapositions to heighten interest.

See also **Art and Fashion; Avedon, Richard; Fashion Advertising; Fashion Magazines; Fashion Photography; Vogue.**

### BIBLIOGRAPHY

- Blanks, Tim. "Beauty and the Beast." *New York Times Magazine*, 23 February 2003.
- DeLano, Sharon. "Dead Girls." *New Yorker*, 3 September 2001, 58.
- Farber, Stephen. "The Bloody Movies, Why Film Violence Sells." *New Yorker*, 29 November 1976, 39–45.
- Hall-Duncan, Nancy. *The History of Fashion Photography*. New York: Alpine Book Company, 1979.
- Hayden-Guest, Anthony. "The Return of Guy Bourdin." *New Yorker*, 7 November 1994, 136–146.

Nancy Hall-Duncan

**BOUTIQUE** Synonymous with the youth movement and counterculture fashions of the "Swinging Sixties," the boutique radically changed ways of making, marketing, displaying, and buying clothing. Names and places such as Mary Quant, Biba, Paraphernalia, the King's Road, and Carnaby Street evoke the spirit of freedom, individuality, and rebellion that characterized the social upheaval of that decade, and defined a style of dressing. As a retailing concept, the boutique is associated with a distinct identity that reflects the taste of the designer or owner; small-scale production with rapid turnover of merchandise; fashion novelty and experimentation; innovative displays and interiors; and an informality among owner, salespeople, and clientele. Although the boutique phenomenon of the 1960s played itself out by the mid-1970s, boutiques remain a vital part of the commercial world of fashion—whether as an individual enterprise or incorporated into a larger setting, such as a department store.

### Origins

Small retailing establishments were not new to the post-World War II period. In the first half of the twentieth century, Paris, London, and New York all had specialty shops. Usually owned by a single designer or proprietor, these operated between the highly exclusive couture houses and the large department stores, and catered to a well-to-do clientele with an emphasis on personal attention to the customer.

As early as the 1920s, Parisian designers began to open small shops within the premises of their *maisons de couture* where they sold a variety of (often less expensive) merchandise including accessories. In 1925 Jean Patou, for example, opened *Le Coin des Sports* (The Sports Corner), a series of rooms on the ground floor of his couture house that offered specialized sports clothing. From its opening in 1935, Elsa Schiaparelli's boutique featured unorthodox and whimsical window arrangements that anticipated the eye-catching, frankly outré displays and interior decor of 1960s boutiques. By the 1950s, boutiques were well-established venues for selling designer clothes and accessories.

### New Consumers, New Producers

The coming of age of the baby boomers in the late 1950s and early 1960s created a new consumer market that significantly affected the boutique explosion. The economic hardships of the war years had ended and a period of prosperity began in both Europe and America. Young men and women not only had money to spend but also sought to distinguish—and distance—themselves sartorially from their parents. Dissatisfied with what they saw as outmoded, irrelevant, and conformist styles promoted by the Parisian haute couture, emerging young designers, particularly in Britain, began to create clothing that reflected a new aesthetic and attitude toward dressing. Equally significant was their determination to produce clothing that was affordable to their peers. Rather than



**A novel window display in the “Lady Jane” boutique on London’s Carnaby Street, 1966.** Boutiques in the 1960s changed the way merchandise was displayed and sold. The shops reflected an informality between the owner and clientele and included novelty fashions, smaller retail volumes, and innovative displays and interiors. © HULTON-DEUTCH COLLECTION/CORBIS. REPRODUCED BY PERMISSION.

work within the restrictions imposed by a couture house or a large manufacturing company, these designers often began by sewing garments in their homes and opening boutiques in out-of-the-way locations.

Dubbed the “Swinging City” by *Time* magazine in 1966, London was the undisputed capital of the youth movement in the early and mid-1960s, and young British designers were in the vanguard of the boutique scene. Of this group, Mary Quant was the highly influential pioneer. Her boutique, *Bazaar*, which she opened on King’s Road in 1955 in partnership with her publicist husband, Alexander Plunkett-Green, and business manager Archie McNair, was the first of its kind. *Bazaar* offered clothing and accessories aimed at a youthful audience ready for fashion that emphasized informality, irreverence, and playfulness.

Quant’s *Bazaar* set the standard for the many boutiques that opened in London and New York in the following decade, including Barbara Hulanicki’s *Biba*; Alice

Pollock’s *Quorum*, which featured clothes by the celebrated husband-and-wife team of Ozzie Clark and Celia Birtwell; the entrepreneur John Stephen’s numerous emporia on Carnaby Street; and *Paraphernalia*, where Betsey Johnson’s exhibitionist designs were modeled by Warhol “superstar” Edie Sedgwick.

### **Boutique Shopping**

Inventive window displays and interior decor not only formed a particular boutique’s image and identity, they also added a sense of fun and discovery to the shopping experience. Unconventional windows were designed to engage—even shock—passersby. At *Bazaar*, Quant created whimsical vignettes using attenuated, stylized mannequins in awkward poses, props, large-scale photographs, and banners. Historicism was the hallmark at *Biba* that would become famous for its art nouveau and art deco inspired interiors (and fashions). *Paraphernalia* was characterized by a space-age minimalism in which white and



silver predominated. In these varied settings, clothes and accessories might be hung on walls or old-fashioned coat stands (as at Biba), or tucked away in dimly lit corners. The unexpected juxtaposition of different types of merchandise also encouraged the boutique shopper to linger and explore.

Although Biba's clientele was primarily working-class while Quorum was patronized by the Rolling Stones lead singer Mick Jagger, Marianne Faithfull, and other pop stars, boutique shopping in the 1960s was a shared social experience among young men and women. Strolling down King's Road or Carnaby Street and frequenting the "in" shops were part of the hip lifestyle. Boutiques were first and foremost places to see and purchase the most up-to-the-minute styles, but they were also "happening" places where one went to meet friends and listen to the latest rock music. Their generally small, often dark interiors and casual atmosphere fostered an intimate ambience. Some boutiques (such as Paraphernalia) stayed open late at night; music and live models dancing on platforms further blurred the distinction between store and party scene.

#### **Boutiques and Fashion in the Early 2000s**

By the late 1960s and early 1970s, the success and popularity of boutiques resulted in their being co-opted by mainstream fashion and big business. In New York, large department stores such as Bloomingdale's opened designer boutiques aimed at attracting a share of the enormous youth market. Geraldine Stutz, president of Henri Bendel, transformed the staid specialty shop into a highly visible showcase for the work of young British, American, and French designers, each with their own boutique space. By the time it closed in 1976, Biba had moved twice from its original, small location in Abingdon Road to occupy the former premises of Derry and Toms, a 1930s multi-storied department store in Kensington High Street.

In the "Swinging Sixties," fashion was a defining aspect of the counterculture movement, and boutiques were the matrix in the creation and dissemination of those fashions. The boutique scene introduced a new set of expectations regarding fashion and shopping that is still a factor in the early twenty-first century. Boutiques expanded the concept of fashion as catering to more individualized—and adventurous—tastes. Along with the multiplicity of styles available was the possibility for creative self-expression through clothing, while the shopping experience became part of fashionable behavior. Boutiques continue to offer alternative fashions to elitist haute couture and mass-produced, mass-distributed ready-to-wear.

See also **Biba; Quant, Mary.**

#### **BIBLIOGRAPHY**

Bernard, Barbara. *Fashions in the 60s*. London: Academy Editions, 1978.

Fogg, Marnie. *Boutique: A '60s Cultural Phenomenon*. London: Mitchell Beazley, 2003.

Fraser, Kennedy. *The Fashionable Mind: Reflections on Fashion 1970–1982*. Boston: David R. Godine, Publisher, 1985.

Lobenthal, Joel. *Radical Rags: Fashions of the Sixties*. New York: Abbeville Press, 1990.

Mendes, Valerie, and Amy de la Haye. *20th Century Fashion*. London: Thames and Hudson, Inc., 1999.

Steele, Valerie. *Fifty Years of Fashion: New Look to Now*. New Haven, Conn.: Yale University Press, 1997.

*Michele Majer*

**BOXER SHORTS** Derived from the loose, full-cut shorts worn by professional boxers in the ring, boxer shorts are cotton or silk underdrawers with an elastic waistband, back panels, and buttoned front closure. The only form of underwear that can still be made to measure, many versions have vents at their sides to allow for ease of motion and to be unobtrusive beneath a well-tailored suit. The term is more often than not, shortened simply to "boxers."

#### **History**

Boxer shorts trace their heritage back to the long woolen drawers worn by boxers in the nineteenth century. But it was when the heavyweight fighters Jim Corbett and Bob Fitzsimmons both abandoned traditional boxers' tights in favor of loose-fitting trunks, at the turn of the twentieth century, that an icon was born. Shorts of similar cut, made of lightweight fabrics, were soon being produced as underwear. Prior to the twentieth century, most men wore undergarments that were akin to those worn as far back as the Middle Ages. They consisted of tight-fitting linen under-trousers of varying length that, rather than having a fly front, had a buttoned opening at the rear.

Boxers gained popularity when they were issued to United States infantrymen for summer wear during World War I. As with many pieces of functional military clothing issued during both World Wars (the parka, duffle coat, trench coat, and T-shirt) soldiers retained their boxer shorts during peacetime and became instrumental in accelerating their adoption by the general population. Soldiers found their baggy undershorts to be comfortable both because of their loose fit and because they allowed air to circulate in warmer temperatures. The association with military men (as well as with professional prizefighters) may also have helped to make boxer shorts a symbol of manliness. Many men prefer boxer shorts to the more restrictive briefs for those reasons.

Although the underwear market has changed dramatically since the 1940s, with many men opting for tighter-fitting styles such as briefs and bikini shorts, men's boxer shorts cut loosely and made of cotton or silk (or a mixture of the two) have remained standard men's wear items. Once made only in white fabrics, boxers are

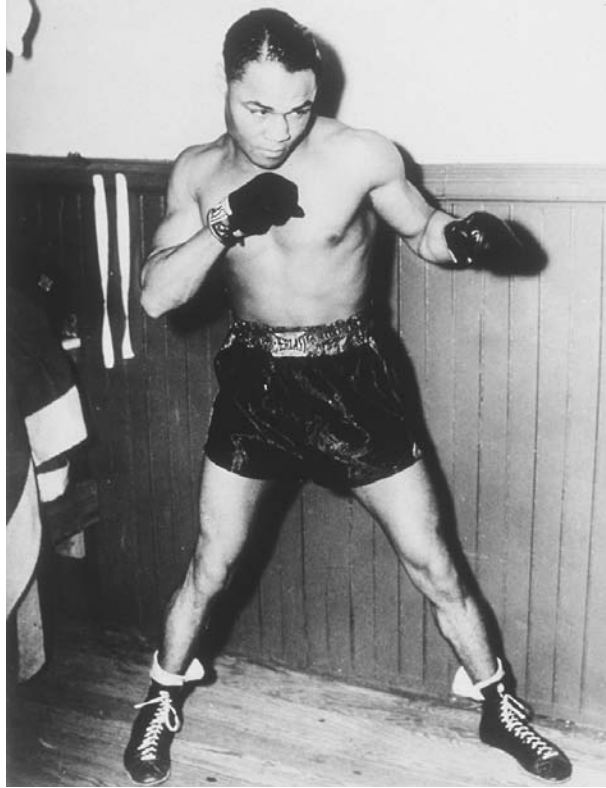

**Champion boxer Henry Armstrong wearing boxer shorts.** Not long after boxers began wearing the looser shorts in the ring, they were produced in lighter fabrics as mens' underwear.  
AP/WIDE WORLD PHOTOS. REPRODUCED BY PERMISSION.

available in every color as well as in novelty prints. Winston Churchill was said to be partial to pink boxer shorts, and Union-Jack boxer shorts were popular at the coronation of George V (they have since been adopted by British football hooligans). Like many other leisure garments, boxer shorts are often heavily branded with conspicuous designer names. Name brand designer versions by Calvin Klein, Ralph Lauren, Armani, Tommy Hilfinger, and many others, of both boxers and briefs have turned the men's underwear trade into a multimillion-dollar industry. Men's underwear is no longer just a functional afterthought to completing a wardrobe, but an element in the creation of a casual-wear image. In the mid-1980s Jean Paul Gaultier paraded a pair of men's trousers down the catwalk with a pair of boxer shorts visibly built in, symbolizing their importance to the new male look.

In the twenty-first century, boxer shorts are still as relevant to men's wear consumers as they have ever been. They have had an entirely new incarnation in hip-hop fashion, which established a trend for wearing them with very low-riding jeans or other trousers, with several inches of cloth (often including a brand-emblazoned waistband) of the boxers clearly visible.

### Boxers or Briefs?

Although few custom tailors will take orders for bespoke boxer shorts any longer, neither will they be impressed with a customer who prefers to wear briefs instead of boxers. Not only have briefs and thongs brought about the tightening of men's trousers, to the dismay of tailors, they may have had adverse health consequences as well. Medical research points to evidence that tight underwear can lead to a low sperm count brought on by increased temperatures. Boxer shorts on the other hand offer the wearer greater movement of air, which keeps the temperature lower. Thus for medical as well as sartorial reasons, boxer shorts seem likely to remain a staple item of male dress. But ultimately the choice between boxers and briefs is an individual one, subject to the essential goals of cleanliness and comfort.

See also **Underwear.**

### BIBLIOGRAPHY

- Byrde, Penelope. *The Male Image: Men's Fashion in England 1300-1970*. London: B.T. Batsford Ltd., 1979.
- Chenoune, Farid. *A History of Men's Fashion*. Paris: Flammarion, 1993.
- De Marley, Diana. *Fashion for Men: An Illustrated History*. London: B. T. Batsford Ltd., 1985.
- Schoeffler, O. E., and William Gale. *Esquire's Encyclopedia of 20th Century Fashions*. New York: McGraw-Hill, 1973.

*Tom Greatrex*

**BRACELETS** Bracelets, cylindrical-shaped ornaments worn encircling the wrist or upper arm, have been one of the most popular forms of ornamentation since prehistoric times. Incredibly varied, bracelets are a universal form of jewelry. Historically and culturally, they have been worn singly or in multiples by both genders. Bracelets have been used for protective and decorative purposes, in rituals, and to indicate one's social status.

### Materials

Materials for bracelets are innumerable. Peoples from all cultures across the globe have used indigenous or imported materials, man-made, and natural materials to make them. While the majority are made from metals, they also have been made from insect secretions (such as lac), rattan, wood, feathers, tortoiseshell, horn, teeth, tusks, feathers, leather, and stone. Man-made materials include glass, faience, enamel, ceramic, and plastic. Ancient Egyptians used bone and pebbles, adorned with finely worked beads and pendants of jasper, turquoise, alabaster, lapis lazuli, cornelian, and feldspar. In Eastern cultures, folk jewelry was often made of horn, brass, beads, and copper, while more expensive and finer quality bracelets were designed of mother-of-pearl, gold, and silver. Skillful jewelers in China were able to make bracelets cut from a single piece of jade. In India, the

*patwa* (jewelry maker) often creates bracelets from braiding, knotting, twisting, or wrapping yarns made of cotton, silk, wool, or metallic fibers.

In the early 2000s bracelets are being made of soft or hard glass (such as borosilicate). While these glass bracelets can be made from molds or be free-formed, the latter process is slower and not nearly as precise. Micro-electronics used in some modern bracelets can now produce movement, light, and sound.

### Styles

There are many different styles of bracelets and where they are worn on the body determines what they are called. For instance, bracelets worn above the elbow are called “armlets,” but “anklets” when worn around the ankle. The main design consideration for a bracelet is sizing; it must be neither so large that it slips off the hand when it is relaxed, nor so small that it cannot be slid over the hand or fit around the wrist. In general, there are three different types of bracelets: link, slip-on, and hinged. *Link* styles are sized to fit the wrist comfortably and to allow the links to drape flexibly. *Slip-on* styles are rigid shapes, and may be either open-ended or a closed circle or other shape. According to one source, solid circle or oval bracelets should be from 8½ to 9¼ inches in circumference. In the early twenty-first century, this is the most common style of the three types. *Hinged* styles require a hinge and locking catch to allow the bracelet to be opened and yet fit the wrist snugly at a recommended 6½ to 7 inches around with an opening of 1 to 1½ inches for the wrist. The bracelet should have rounded ends in order to fit the wrist comfortably. Solid hinged bracelets should be made from a thick gauge of metal (from 12 to 14 gauge) to maintain the necessary springiness of the form. Stones inserted in bracelets should rank at least 5 or 6 on the Mohs’ scale, to prevent their damage.

Every period in history has had an impact on bracelet styles. Styles can range in complexity—from simply sawing off part of a mollusk shell to the intricate designs evident in East Asian metalworking. During the twentieth century, bangles, charm bracelets, and identification bracelets were some of the most popular styles.

Bangles are rigid bracelets with no closures, and may be worn singly or in multiples. Most bangles are made from bold colors or are decorated with numerous types of repeating motifs.

Charm bracelets are a special and unique type of jewelry with a long history dating back to Ancient Egypt. Charms were meant to ward off evil or to endow the wearer with special powers. The original charm bracelet was the Egyptian eye bead, attached to a circlet, used to charm, fascinate, or reflect the malevolent intention of others. Its spiritual function became so popular, it was adopted by neighboring cultures, and it is still worn today in many Middle Eastern countries. In the United

States, charm bracelets gained popularity during World War II. Made of silver, gold, or silver-plated metals, enamel, plastic, and shell, most were inexpensive and mass-produced. The charms included military insignia, flags, planes, and wings worn by women in recognition of those serving in the armed forces. Postwar prosperity turned the inexpensive charm bracelets into fine quality jewelry made of medium to heavy gold links on which charms could be attached.

In the late 1950s, charms representing one’s travel experiences became fashionable, and there is still a wide range of charms available. Like quilts, letters, and journals, these types of bracelets have a narrative quality that define some of the more important moments in a woman’s life, or share information about her values, beliefs, interests, and personality.

Identification, or ID, bracelets are twentieth-century link bracelets with text engraved onto a flat metal plate. The text could be one’s name or nickname, or it could contain important information about an individual’s medical condition. One fashion trend in the United States has been stylish medical-alert bracelets, which have the primary function of alerting medical professionals to special medical considerations like diabetes or an allergy to penicillin. In the early 2000s, they also have an aesthetic appeal, as some of these bracelets are made with crystal, sterling silver, and 14-karat gold-filled beads, hooked onto a stainless steel medical-alert tag.

### History

After neck ornaments, bracelets for the wrist, arm, or ankle are perhaps the oldest form of jewelry. One of the first written records of humans wearing bracelets is in the Hebrew Scriptures. The Bible mentions that there are three types of bracelets: one worn exclusively by men, one worn only by women, and one that may be worn by either sex. Although bracelets are mentioned frequently in the Hebrew Scriptures, their distinctive characteristics are not described. Some of the oldest bracelet artifacts were constructed of bronze and gold and date back to the Bronze Age. Most were penannular, or oval, with expanding, trumpet-shaped ends. The gold bracelets were typically unadorned, and hammered and bent into shape, while bronze bracelets were decorated with patterns and designs. At about this same time, German and Scandinavian warriors often wore spiral armlets for decorative and protective purposes. These armlets covered the entire forearm. In pre-Columbian America, indigenous artisans made bracelets from gold, precious minerals, and rock crystal.

In Ancient Egyptian tombs, strings of gold beads, hoops, and single, hinged bracelets have been discovered. Many of the bracelets made from plain or enameled metals were unadorned by stones. During the First Dynasty, bracelets worn by royalty were made of rectangular beads called *serekhs*, with turquoise, gold, and blue-glazed compositions. In Ancient Minoan and Mycenaean periods,



bracelets were made of sheet metal and had elaborate loop-in-loop chains. Ancient Assyrians and Greeks often had two types of bracelets: coiled spirals in the form of interlocking snakes and stiff penannular hoops with enameled sphinxes, lions' heads, or rams' heads. In the Iron Age these spiral forms were common in Europe as well. Scythian nobles wore rigid gold bracelets with animal motifs around the eighth century B.C.E. The Scythians, a group of powerful, nomadic tribes of southeastern Europe and Asia, were known for their fine metalworking and artistic style.

The Etruscans were among the first to create bracelets with separate, hinged panels, a style still popular in the early twenty-first century. Ancient Roman soldiers often were given gold bracelets to indicate their valor in battle. In Great Britain during the Celtic period, men often wore massive protective armllets and serpent-shaped bracelets. These may have been an adaptation of German and Scandinavian bracelets worn during the Bronze Age and used to protect against sword attacks. Toward the end of the pagan period in Europe, plaited silver bracelets and intertwined strands of silver wire became popular. A decline in interest in bracelets occurred during the Middle Ages in Europe, probably due to the fact that Christian beliefs discouraged adornments, as they suggested an "unhealthy regard for personal vanity" (Trasko, p. 27). The Renaissance focus on humanism prompted a renewed interest in bracelets and other types of jewelry.

### Cultural Examples

Bracelets have been worn by cultures all over the world since ancient times. Bracelets and other forms of jewelry were considered especially important in warm geographic regions, such as India and Africa, where few items of clothing were worn. Although both genders historically have worn bracelets, they seem more typically associated with women, especially in contemporary times. Cultural variations may be seen in the wearing of bracelets, for example, in the number of bracelets worn. In the United States, wearing one bracelet is common; however many Eastern cultures favor wearing several bracelets on one wrist. Some cultures in India wear anklets and armllets, as well as bracelets, while this is not as common in Western nations. In addition, Westerners often view bracelets as transitory, removing them at the end of the day. Married women in India, however, wear conch and glass bangles for life. They are broken only if the women becomes a widow.

While many cultural examples of bracelets abound, the intricacy of meanings behind bracelets are found among the people of Timor, a remote island in Indonesia. In Timor, bracelets are natural, stylized, or abstract. Using the lost-wax process, which requires a new mold for each bracelet, ensures a one-of-a-kind result. Timorese bracelets, as family heirlooms or household treasures, may indicate a marriage alliance, social status, and serve as protective amulets or as important artifacts for

ritual dances and other ceremonies. In premodern times, bracelets also were badges awarded for the taking of heads. The Timorese have special bracelets for fertility, life cycle and life crisis ceremonies, and other important cultural rituals. Timorese men wear the most spectacular bracelets; the women's are similar in style, but smaller in size. Many bracelets display a traditional symbol indicating one's relationship to a specific Timorese house or family, called an *uma*.

See also **Costume Jewelry**; **Jewelry**.

### BIBLIOGRAPHY

- Evans, C. *Jewelry: Contemporary Design and Technique*. Worcester, Mass.: Davis Publications, Inc., 1983.
- Ferris, M., and Y. Markowitz. "Charm Bracelets: Portable Autobiographies." *Ornament* 21, no. 4 (Summer 1998): 54–57.
- Gill, B. "Jewelry from Yarn: The Indian Patwa." *Fiberarts* 28, no. 1 (Summer 2001) 21.
- Goldberg, N. *Jewelry*. New York: Hart Publishing Company, 1977.
- Kennard, S. J., III. "Timorese Tribal Bracelets: A Cultural Perspective." *Arts of Asia* 25: 62–69.
- Liu, R. K. "Adorning the Wrist." *Ornament* 23, no. 2 (Winter 1999): 62–63.
- . "Kevin O'Grady: Borosilicate Glass Art." *Ornament* 25, no. 3 (Spring 2002): 60–63.
- Morton, P. *Contemporary Jewelry*. New York: Holt, Rinehart, and Winston, 1970.
- Strote, M. E. "Stylish Safety Bracelets." *Shape* 22, no. 6 (February 2003): 62.
- Tait, H., ed. *Jewelry 7,000 Years: An International History and Illustrated Survey from the Collections of the British Museum*. New York: Harry N. Abrams, 1986.
- Trasko, M. *Daring Do's: A History of Extraordinary Hair*. New York: Flammarion, 1994.
- Von Neumann, R. *The Design and Creation of Contemporary Jewelry*. Rev. ed. Radnor, Pa.: Chilton Book Company, 1961.

### Internet Resource

"Beautiful Bangles" (2000–2003). Available from <<http://www.glamourdome.com/home.asp>>.

*Julianne Trautmann*

**BRAIDING** The word "braid" has many different meanings that change over time and between social groups. For example, a braided fabric once meant material that had faded, but this definition is obsolete now. In the United States, the common use of the word "braid" would be called a plait in the United Kingdom. With global communication becoming commonplace, the problem of terminology increases in importance, as agreed definitions create a common understanding of terms.

International authorities still differ in their opinions. In *The Manual of Braiding*, Noemi Speiser defines "braid-

ing” as “interworking a set of elements by crossing, interlacing, interlinking, twining, intertwining” (p. 146). On the other hand, Irene Emery in *The Primary Structure of Fabrics* sees braiding only as oblique interlacing (p. 68). This leaves a problem of classifying such braid techniques as card weaving, making inkles, cords, knotting, knitting, or lucet work. All these techniques as well as structures made using stand and bobbin equipment, free-end braiding, ply-split, and loop manipulated pieces are part of the costume world, though only some would be defined strictly as “braids.”

Some of these techniques used to be domestic skills while others were more specialized methods, made in workshops after long training. In the domestic range come lucet work and loop-manipulated braids. Loop manipulation has a very long history and can be simple as the braids used as ties for clothing or to assemble samurai armor, or it can be very complex and decorative. We know from seventeenth-century household pattern books that these braids were in common use for all manner of things from purse strings to ties for clothing, and by the end of the eighteenth century a lucet was a common tool in most households, making ties for stays and other lacings. Reference has been found in the seventeenth and eighteenth centuries to the inkle loom, which was developed for the making of garters, sashes, and other necessary ties.

While not always considered braiding, card weaving, which dates far back into European history, is a weaving technique in which the warp threads, running the length of the work, are held by cards with holes at the corners. The textile is made by turning the cards to change the shed, the space between the warp threads, for the insertion of the weft, the threads running across the piece. It makes highly complex and decorative wares that have been found on early garments worn by the nobility and senior clerics. A medieval tomb opened during the restoration of York Minster contained card-woven edgings on vestments. Older pieces have been found in excavations in Verucchio, Italy, where they were used as edging for cloaks. Some of these were used as the starting edge of the garment while others were skillfully woven using the ends of the cloak warp as the weft to incorporate the edging into the garment.

Pieces made on stands with the threads on bobbins are chiefly associated with countries in the Middle and Far East, although they are not unknown in Europe. In Japan, braids made on equipment such as the circular warp loom, or *marudai*, were used as braids for ties (*obi-jime*) worn with kimonos. In Europe, a method for making a braid using bobbins is described by Lady Bindloss in the seventeenth century while *Diderot's Encyclopedia of Trades and Industry*, first published in 1751, illustrates two types of stand and bobbin equipment. In the early 2000s, the main use is in Sweden where the craft of hair braiding continues in the making of jewelry, and in many places, in the use of equipment to make decorative pieces

traditionally associated with Japan. A technique such as free-end braiding, where the work is attached to a fixed point at one end and then worked in the hand, is still in use. Notable among these are the Dida skirts made from many hundreds of threads, attached to the worker's toe and then braided in the weaver's hands into a tubular garment.

Braids have been used for ties such as stay lacing, shoelaces, and points; to secure clothing as braces, belts, and garters; for ceremonial pieces and those with specific meanings such as military braids, and for decoration as in the Miao silk work from China and Khajuja work from the Middle East, while in Peru very old and varied patterns are used to make slings. North American First Nations produced long, wide sashes and belts, often with beads and cross-fertilized with European techniques and ideas. Braids are still being used for some of these things; although in the early twenty-first century, braids for costumes in the Western world are either mass produced or made as individual pieces by skilled makers. Ply-split, a technique originally used mainly, but not exclusively, for animal regalia in India, is being developed for highly decorative accessories, such as belts and bags, for neck pieces, bracelets, and even whole garments. There are also many developments in making jewelry pieces on stand and bobbin equipment.

See also **Homespun; Knitting; Knotting; Loom; Weaving.**

#### BIBLIOGRAPHY

- Cahlander, Adele. *Sling Braids of the Andes*. Weavers Journal Monograph IV, 1980.
- Campbell, Mark. *The Art of Hairwork* [1867]. Petaluma, Calif.: Unicorn Books, 1989.
- Collingwood, Peter. *The Technique of Ply-Split Braiding*. Petaluma, Calif.: Unicorn Books, 1998.
- Dendel, E. W. *The Basic Book of Finger Weaving*. New York: Simon and Schuster, 1974.
- Dyer, Anne. *Purse Strings Unravelling*. London: Dyer, 1997.
- Emery, Irene. *The Primary Structure of Fabrics*. London: Thames and Hudson, 1966.
- Fuller, Elaine. *Lucet Braiding*. Berkley, Calif.: Lacis Publications, 1998.
- Owen, Roderick. *The Big Book of Slings and Braids*. London: Cassell, 1995.
- Speiser, Noemi. *The Manual of Braiding*. Basel, Switzerland: Speiser, 1983.
- . *Old English Pattern Books for Loop Braiding*. Basel, Switzerland: Speiser, 2000.
- Sutton, Ann, and Pat Holtom. *Tablet Weaving*. Newton Center, Mass.: Charles T. Branford Company, 1975.
- Tada, Makiko. *Comprehensive Treatise of Braids I*. Japan: Texere Inc., 1997.
- . *Comprehensive Treatise of Braids III*. Japan: Texere Inc., 1999.

Jan Rawdon Smith

**BRANDING** Branding is a body modification that permanently transforms the surface of the skin by causing a visible scar. The process of branding involves extreme heat or cold applied by a variety of methods. The branding burns and destroys the surface tissue of the skin and stunts or permanently changes the color of hairs growing from the resulting scars.

### Historic Branding

Historically, branding has been used on the skin of animals and slaves, as a proof of ownership, and on the skin of criminals as proof of guilt. In Greece, Rome, and many parts of Europe convicted criminals were branded with specific marks that indicated their crime. French, English, Dutch, Spanish, and Portuguese slave traders branded their initials on slaves each time the slaves changed owners.

### Contemporary Branding

In the twentieth and twenty-first centuries, microcultures, such as the modern primitives and punks, utilize branding as body modifications. These brandings visually indicate group identity, personal identity, rites of passage, spiritual beliefs, and body decoration. Fraternity members, such as Michael Jordan and the Reverend Jesse Jackson, also have brandings of their Greek fraternity letters. These brandings indicate lifelong membership and commitment to their fraternity's ideals and bylaws.

### Strike Branding

Strike branding is the most common form of branding. A strike refers to an individual branding “hit” to the skin. Brandings can be created with either one strike or multiple strikes. The one-strike brand is pressed to the skin long enough to burn through all of the surface skin. The multiple-strikes brand divides the design into many smaller sections about an inch long, shorter if the branding has smaller details. Strikes will overlap and some areas may be re-branded for consistency. A uniform branding requires that all of the strikes be evenly distributed in relation to the surface of the skin.

The strike iron should be hot enough to cause third-degree burns to skin tissue, in order to form a permanent scar. Sources of heat can be anything from a propane torch to an open fire. Strike brand instruments are fabricated from metal, either as complete tools or as small, shaped designs held by a gripping tool. Metal retains and transfers heat effectively, quickly, and predictably to the skin.

Most strike branding tools are made from thin, high-grade stainless steel sheet metal. Other materials used as branding tools include the following: silver, copper, random metal findings, and ceramics. Thin materials are preferred for branding irons, because they are easy to heat and form, and decrease the risk of unwanted damage.

### Cautery Branding

Cautery branding uses modern tools and technology, such as soldering irons and lasers, to apply the branding. An electrocautery unit, invented by Steve Haworth, has been called laser branding. This branding technology is similar to an arc welder, but designed for the skin. The body is negatively grounded while the positively charged electric spark jolts from the branding electrode to the skin, searing the skin tissue it touches. An electrocautery unit provides precise control over the depth of the brand and intricate nature of the designs. Cautery branding, regardless of the tools and technology utilized, is considered to be the most painful form of branding.

### Chemical or Freeze Branding

Freeze branding is similar to strike branding. Instead of putting the branding iron into a fire to heat it, it is immersed into liquid nitrogen or another cooling solution. The iron is then pressed into the skin. If the hair grows back it will be white. Freeze branding takes longer to do than fire branding and may take days to become visible, while fire branding shows results immediately. This branding method is extremely rare and not often used among body modification enthusiasts, but ranchers consider it as an extremely effective method for branding their livestock, because it does only minor damage to the hide and leaves distinctive branding marks of white hair.

### Branding Health Hazards

Branding fumes contain dangerous biological substances from the skin of the person being branded. While some of these airborne viruses and bacteria are dangerous to humans, the heat of the branding destroys most of these germs that can affect humans. Still, branders use HEPA air filters, ventilation systems, and respiratory masks while branding to prevent the transfer of airborne viruses and bacteria.

### Branding Aftercare and Healing Process

There are two schools of thought regarding the aftercare of brandings—LITA or “leave it alone,” or irritation. Leaving the branding alone will allow the body to heal consistently; however, if a person is not genetically disposed to keloiding, the raised area of the scar will be minimal. Irritating a healing branding wound increases the height of the resulting scar; however, it also produces unpredictable healing and scarring. Picking or rubbing the healing area with steel wool or a toothbrush, or using exfoliating agents can successfully irritate the healing branding.

The healing process for brandings usually lasts at least a year. Separate from the pain of the branding procedure, during the healing process the branded area will be extremely sensitive and sore. If the branding is on a body part that flexes, it may cause the wound to tear open



during movement. Healing brandings undergo a few phases, which vary in length and extremes from person to person. A branding will first scab over, which can last from a few weeks to just over a month. At this phase, the appearance of the branding is a bright red raised scar, which slowly becomes lighter than the normal skin tone. This phase lasts about twelve months, and the scar tissue may rise slightly more during this time.

The appearance of a healed strike branding ideally is a design of thick raised lines, lighter than the skin's natural tone. The height of the branding varies significantly on a large number of variables, such as the method of branding, body part and area branded, and skin texture. Strike brandings produce thicker, raised scars, whereas cautery brandings produce thinner lines. Brandings typically heal three or four times the width of the branding tool used to make it.

### Branding Removal

Cosmetic surgery claims the ability to remove a branding by using lasers or other advanced techniques; however, it is expensive and not always successful. Currently it is not possible to completely remove a branding without leaving some type of scar.

See also **Punk; Scarification; Tattoos.**

### BIBLIOGRAPHY

- Beck, Peggy, Nia Francisco, and Anna Lee Walters, eds. *The Sacred: Ways of Knowledge, Sources of Life*. Tsaile, Ariz.: Navajo Community College Press, 1995.
- Camphausen, Rufus C. *Return to the Tribal: A Celebration of Body Adornment*. Rochester, Vt.: Park Street Press, 1997.
- Mercury, Maureen. *Pagan Fleetworks: The Alchemy of Body Modification*. Rochester, Vt.: Park Street Press, 2000.

Theresa M. Winge

**BRANDS AND LABELS** Brands developed as a means of commercial distinction within the marketplace in the mid- to late-nineteenth century. The process of branding begins with the attachment of a name to a business, product, or a family of products, and involves the creation of an image for that business which sets it apart from its competitors. Brand image is usually disseminated through advertising, but the value of a brand generally resides in its reputation and the level of loyalty or desirability it can generate amongst consumers. In the fashion industry, a desirable brand name allows companies to bridge the gap between expensive, high-fashion garments and affordable mass-market goods such as perfumes, accessories, and ready-to-wear diffusion lines.

The emergence of brands is closely linked to the establishment of copyright, patent, and trademark legislation in the nineteenth century, as this allowed companies

to legally protect their names, and seek redress from their imitators. Many other factors affected the emergence of modern brands, such as the growth of new distribution and retail networks; the increased dominance of fixed-pricing, the concomitant growth of the advertising and packaging trades, and the shift from local to national (and international) markets for consumer goods.

The fashion industry can seek legal protection for designs through patents legislation, which protects the unauthorized use of original designs for manufacture. It also benefits from complex trademark legislation, which protects the words, names, symbols, sounds, or colors that are used to distinguish goods and services. Effectively, this covers the use of a company's logo and brand identity from both counterfeit and "look-alike" goods, where the visual identity of brand is suggested rather than exactly copied.

One celebrated early example of branded clothing is Levi Strauss and Co., who incorporated many trademarked features into their garments (such as rivets and stitching) and gave proof of authenticity in the form of a patent and trademark "certificate" with each garment (later to be sewn on as a label). Authenticity is a central promise of branded goods, and the fashion industry has used it to generate high cultural value in a world of rapid turnover, fluctuating consumer loyalties, and the seemingly incessant demand for novelty. Fashion branding has become synonymous with a late-capitalist consumerist culture where it is the experience rather than the product that drives demand.

Many fashion houses developed as brands through the practice of franchising and licensed copying. In the period 1880–1914, couture businesses such as Worth and Paquin sold through an international network of department stores. In their attempts to cut down on illegal copying, they also sold reproduction rights to private dressmaking salons. The copying of models was a fundamental part of the nineteenth century fashion trade, and designer "names" such as Worth would produce models specifically for copy by retailers in both Europe and America, in order to gain some financial benefit from this practice. By the 1860s it was necessary for Worth to incorporate a house label into products, carrying the Worth name and address either stamped or woven into garments (labels were in turn copied by counterfeit producers).

This two-tier system of couture models and more accessible ready-to-wear lines bearing the same label was exploited by successive generations of designers, including Paul Poiret and Coco Chanel, who used it to build their international reputations. The "signature label" became a defining characteristic of twentieth-century fashion, allowing fashion houses and named designers to attach their names to goods including fashion, perfume, cosmetics, and even household products in order to give these goods distinction. In this way, fashion branding

moved beyond the “naming” of a product into the creation of desirable lifestyle scenarios, which could supposedly be replicated by consumers purchasing even the smallest named item. During the 1930s, most of the major couture labels including Elsa Schiaparelli, Coco Chanel, and Jean Patou successfully marketed their signature perfumes well beyond the market for couture.

Franchising became a more widespread activity in the postwar period. Designers such as Dior used the success of franchise agreements in the 1940s to underpin the more risky business of couture. In the 1970s and 1980s designers such as Paco Rabanne, Pierre Cardin, Calvin Klein, and Ralph Lauren capitalized on the value of their brands by franchising their names to the producers of housewares, accessories, and beauty lines. Some labels quickly became debased by the lack of quality control, and crossed the fine line from exclusivity to down-market ubiquity. Now that the practice is more commonplace, it is also more heavily controlled by the presence of major global conglomerates such as LVMH and the Gucci Group. Many brands, such as Donna Karan, have successfully created a family of brands or diffusion lines, each of which has a specific character and target market (Donna Karan and the various DKNY lines including Kids, City, Sport, and Pure).

Aside from the diversification of fashion houses, brand culture has also been driven by the expansion of the sports and leisure sectors into fashion. Despite its claim to be motivated only by the needs of athletes, the global sportswear brand Nike has become synonymous with street fashion since its diversification in the mid-1980s. Nike’s phenomenal expansion was also due to its direct appeal to a sense of personal achievement through its “Just Do It” slogan and highly emotive advertising. It also fueled overt brand loyalty on the part of its wearers. The popularity of branded goods amongst closely defined “style tribes” has resulted in a profusion of goods where the logo is prominently displayed.

By the twenty-first century, investment in brand building has reached unprecedented levels, with many familiar brand names reinventing themselves by the hire of celebrity designers and radical company overhauls. Fashion and luxury brands have been most affected, as brands known for a particular product category (such as leather goods) launch couture and ready-to-wear collections. With a combination of business acumen and designer credentials, brand “auteurs” such as Tom Ford have transformed the fortunes of a company such as Gucci in a few short years. Many individual designers now work in several capacities at once: creating their own couture and ready-to-wear collections, producing a collection for another fashion house (John Galliano and Alexander McQueen have both held this post at Givenchy) and perhaps acting as consultant to a department store’s own label (Betty Jackson for Marks & Spencer, Jasper Conran for Debenhams in the United Kingdom). These designers

may risk their individual reputations on the success of named collections, but the companies behind them are now multinational conglomerates, each with a huge portfolio of brands.

*See also* **Logos.**

#### BIBLIOGRAPHY

- Clifton, Rita, and John Simmons, eds. *Brands and Branding*. Princeton, N.J.: Bloomberg Press, 2004.
- Mendes, Valerie, and Amy de la Haye. *20th Century Fashion*. London: Thames and Hudson, 1999.
- Pavitt, Jane, ed. *Brand New*. London: V & A Publications, 2000.
- Troy, Nancy J. *Couture Culture: A Study in Modern Art and Fashion*. Cambridge, Mass.: MIT Press, 2003.
- White, Nicola, and Ian Griffiths, eds. *The Fashion Business: Theory, Practice, Image*. Oxford: Berg, 2000.

*Jane M. Pavitt*

**BRASSIERE** A brassiere is a garment worn next to the skin with two shaped cups or pockets to hold female breast tissue; it is supported by a chest bandeau and generally two over-the-shoulder straps. It may have elastic, wire, padding, lace trim, and a variety of other parts. Strapless versions are also used on occasions where the shoulders are exposed. Specialized brassieres are made for holding breast prostheses of those with surgical removal of one or both breasts, in addition to the particular needs of maternity and nursing mothers. Brassiere styles are often dependent on the fashionable silhouette of the time: breast-flattening bands of the early 1920s, softly curved bias-cut styles of the 1930s, structured and circular stitched “torpedo” shapes of the 1940s and 1950s, unstructured and naturally shaped bras of the 1960s and 1970s, until the introduction of the Lycra-based knitted fabric sports bras of the 1980s. Any of those could be found in lingerie wardrobes, along with the ultimate in uplift and underwire by Wonderbra, Victoria’s Secret, Warnaco, and others. It is not anatomically or physiologically necessary to support the breasts, but is strictly a fashionable or socially demanded item.

Breast coverings, in the form of tight bandeaus, have been worn throughout history and by many different ethnic groups of women, but the particularly designed and shoulder-supported garment we know today was a product of the nineteenth-century Dress Reform. United States patent #40,907 issued to Luman L. Chapman in 1863 may be the first recorded design in America, but is almost certainly not the first such garment produced for women wishing to substitute a more comfortable garment for their fashionable tight-laced corsets.

A Norman French word for a child’s undershirt, the term “brassiere” was adopted in America about 1904 when it appeared in New York advertising copy of the DeBevoise Company to describe their latest bust supporter, thus giving it French cachet. Prior to that time,



## Special Values in Attractive Brassieres

**32D7488**  
Your Choice for **39c**



**32D7484**  
**32D7480**

**Cambric Brassieres**  
Your Choice Each **39c**  
Three for **\$1.14**

Sizes, 34 to 48-inch Bust.  
Ship. wt., 5 oz.  
State bust measure.

Women's Brassieres of fine Cambric. 32D7488 is trimmed with lace in cluny pattern and 32D7480 and 32D7484 embroidery trimmed. Open front. Corset hook attached.



**Cambric and Lace**  
Each **79c**  
Three for **\$2.30**

**32D7539**  
Pink  
**32D7539**  
White.

Sizes, 34 to 48-in. Bust.  
Ship. wt., 3 oz.  
State bust measure.

Brassiere of good quality Cambric and lace in cluny pattern. Back and front yoke alike. Trimmed with ribbon bow. Reinforced under arms. Corset hook attached.

**32D7520**  
Your Choice for **63c**



**32D7508**  
**32D7456**  
**32D7457**

**Cambric Brassieres**  
Your Choice for **63c**  
Three for **\$1.84**

**32D7456**—Pink.  
**32D7457**—White.  
**32D7508**—White.  
**32D7520**—White.

Sizes, 34 to 48-in. Bust.  
Shipping weight, about 5 oz.  
State bust measure.

Material is of good quality cambric. Front and back yokes alike, one is trimmed with wide embroidery insertion and the other two with lace in cluny pattern. Open front. Corset hook attached.

**Wash Silk**



**Cambric Brassiere**  
Each **59c**  
Three for **\$1.72**

**32D7460**

Sizes, 34 to 48-in. bust. Shipping weight, 5 oz. State bust measure.

Open front Brassiere of fine Cambric. Front and back yoke and bottom of wide embroidery in cluny pattern. Reinforced under arms. Corset hook attached.

**Cambric and Lace**  
Each **98c**  
Three for **\$2.85**

**32D7512**

Sizes, 34 to 48-in. bust. Shipping weight, 3 oz. State bust measure.

This Beautiful Brassiere is made of soft finished Cambric and lace in cluny pattern. Yoke finished with ribbon bow. Reinforced under arms. Corset hook attached.



**Embroidery Trimmed**  
**32D7511**—Each ..... **\$1.19**

Sizes, 34 to 48-inch bust. Ship. wt., 3 oz.

Open front Brassiere of good quality soft finish cambric. Front trimmed with wide embroidery insertion finished with ribbon bow. Reinforced under arms. Corset hook attached.

**Silk and Lace**  
Each **\$1.09**  
Three for **\$3.16**

**32D7438**

Sizes, 34 to 48-in. Bust. Ship. wt., 3 oz. State bust measure.

Beautiful Brassiere made of flesh color wash silk and lace in cluny pattern. Front and back alike. Reinforced under arms. Corset hook attached. Open front. Ribbon run at neck.



**Cambric and Lace**  
Each **97c**  
Three for **\$2.85**

**32D7436**

Sizes, 34 to 48-in. bust. Ship. wt., 3 oz. State bust measure.

Open front Brassiere of good quality Cambric and lace in cluny pattern. Front and back alike. Reinforced under arms. Corset hook attached.



**Lace Bandeau**  
Each **69c**  
Three for **\$2.00**

**32D7427**

Sizes, 34 to 48-in. bust. Shipping wt., 3 oz. State bust measure.

Bandeau of heavy quality lace in cluny pattern. Lace shoulder straps. Opens in back. Corset hook attached.



**Shield Brassiere**  
Each **69c**  
Three for **\$2.00**

**32D7441**

Sizes, 34 to 48-in. bust. Shipping weight, 3 oz. State bust measure.

Shield Brassiere of fine white mesh with dress shields. Draw tape at neck. Open front. Corset hook attached.



**Cambric Brassiere**  
Each **89c**  
Three for **\$2.59**

**32D7447**

Sizes, 34 to 48-in. bust. Ship. wt., 3 oz.



**Cotton Mesh Bust Confiner**  
Each **39c**  
Three for **\$1.14**



**Lawn and Lace Bust Ruffle**  
Each **39c**  
Three for **\$1.14**



**Fancy Batiste**  
Each **39c**  
Three for **\$1.14**



**Elastic and Cambric**  
Each **\$1.09**  
Three for **\$3.16**

**32D7514**



**Brassiere advertisement.** This advertisement shows the soft, curved bias-cut styles popular in the 1930s. The French word *brassiere*, adopted in the United States about 1904 when it appeared in an advertisement in New York, gave the garment a French quality. They were previously known as "bust, bosom, or breast supporters/corsets." © BETTMANN/CORBIS. REPRODUCED BY PERMISSION.





**Maiden Form advertisement.** This advertisement was part of an exhibit at the “Enterprising Women: 250 Years of American Business” at the National Heritage Museum in Lexington, Massachusetts, in 2002. The design shows a brassiere, boxing gloves, and athletic trunks. AP/WIDE WORLD PHOTOS. REPRODUCED BY PERMISSION.

the garments specifically designed for breast covering and support were designated variously as bust, bosom, or breast supporters or corsets. Occasionally they were patented as braces, waists, foundation garments, halters, or simply covers. The term “brassiere” became widespread in English-speaking nations within a few years, but the French have maintained their designation of *soutien-gorge* (literally “bosom supporter”). In the 1930s, when slang shortened words like pajamas to “pj’s,” brassieres became “bras.” Custom-made in the nineteenth century, the brassiere made its entrance into mass production in the early twentieth century in the United States, England, western Europe, and other countries influenced by Western lifestyles.

The brassiere had early prototypes in undergarments worn by late eighteenth-century Western European women with the lightweight columnar fashions that emphasized the breasts and deemphasized the natural waist. Those unstructured pouchlike garments, fitted by draw-

strings, and commonly held by shoulder straps, may have inspired the dressmakers and reformers who attempted to produce garments later in the nineteenth century. One function that corsets provided was to help disperse from the waist, the weight of the crinolines, petticoats, and skirts, which may have been as much as thirty-five pounds. A garment with shoulder straps could transfer this weight to the shoulders by hitching lower garments to hooks and tapes. Dress Reformers, including about half of the doctors in a survey of the mid-nineteenth-century medical literature, encouraged women to wear garments that would not impede their digestion, lung capacity, or reproductive system; the new designs maintained the fashionable shape without harming the physique.

Several dozen American entrepreneurs patented breast-supporting garments in the decades up to World War I; about half were women. Olivia Flynt, Marie Tucek, Caroline Newell, and Gabrielle Poix Yerkes were early patentees and producers, with dozens following in the twentieth century. In the undergarment industry, enterprising women found opportunities in design, production, and management not readily available to them in other clothing manufacture. Dr. Jeanne Walters patented rubber brassiere designs with weight-loss claims; and Herma Dozier, R.N., patented three maternity and nursing bras for her company Fancee Free. The latter employed adjustable flaps to allow nipple access without removing the supporting garment. By the end of World War II, the vast majority of fashion-conscious women in America and Europe were wearing brassieres. Western fashions introduced the brassiere to Asia, Africa, and Latin America.

There have been many attributions about the invention of the brassiere. One oft-repeated story concerns Mary Phelps Jacob (a.k.a. Caresse Crosby), a self-described New York socialite who patented a bias-cut brassiere in 1914; it was neither first nor successful. Frenchwoman Herminie (Herminie) Cadolle set up a lingerie business in Argentina just as rubber fabric became available and parlayed her elastic insert brassieres (not unlike L. L. Chapman’s 1863 design) into a fortune and eventually moved back to Paris, where her business survives in the early 2000s. Claims to her invention of the shoulder strap are misplaced. The Warner Corset Company of Bridgeport, Connecticut, also professed invention, but can only declare innovation and patents for several excellent designs, mostly after 1890. The Gossard Company dominated the English market for many years, with many unique adaptations in brassieres. In fact, there were hundreds of innovators. Not all patented designs, but many found success in the marketplace as women demanded more comfort in their clothing and fashion moved away from the rigid silhouettes of the nineteenth century. In a changing society, women entered universities and work places in great numbers, they took part in sports like hiking, tennis and bicycling, and they drove

cars, activities that demanded greater freedom of movement and lung capacity than allowed by restrictive corsets.

As the idea of the brassiere became popular, patterns for the home seamstress were available, but the intricacy of stitching required skills practiced by specialists. Dozens of small entrepreneurial firms entered the market to supply the growing demands for brassieres. Production could be mastered and as assembly lines using readily available components were set up in small quarters, the industry flourished. Designs were patented by the hundreds, along with specialized machinery for cutting, sewing, making fasteners, and even packaging as sales of brassieres increased. Special industries produced the rust-proof wires, hooks, fasteners, and straps in addition to the fabrics, elastics, lace trims, stitching machines, and molding units. Brassiere construction involves up to forty components per garment, using specialized machines for cutting and sewing. In early designs, chromium wire fasteners were the norm; these have been largely replaced by plastic components, which like straps are produced by specialized firms. Improvements in rubber and synthetic elastics have resulted in their almost universal use in brassieres. Fabric selection for brassieres has evolved from the firm coutil and twill weaves used in the nineteenth century to the fine cottons, embroidered polyester blends, delicate silks, fiberfill, and soft knits of the twenty-first century. The brassiere business gave opportunity to women in ownership, administration, design, and manufacturing not readily available in other fields. There were some self-regulatory aspects within the industry, particularly regarding nomenclature. What differentiated a bandeau from a brassiere was more than two inches of length below the breasts. Until war shortages created problems with supplies, there were few government regulations for work standards or for wages.

By the 1910s, retailers featured specialist “fitters” in departments devoted to corsets and brassieres, which did not have universal cup sizing until the early 1930s. Brassieres, like other items of clothing, were sewn in small production companies, often by sweated labor. Despite demands of complicated designs, sewers were expected to produce items of uniform style and size. The term “cup” was not used until 1916, and letter designation for cup size was first used about 1933 by S. H. Camp and Company to imply progression in volume of breast tissue to be replaced with their prostheses. The under-breast circumference or band dimension is one part of early twenty-first-century brassiere size, with the cup volume designated in letters AA thru I available in retail outlets. Introduction of the minimally shaped “training bra” in the 1950s opened the fashion door for countless adolescents.

Fabrics that could be sewn with flat-felled or bias-tape covered seams were used to ensure comfort to the wearer. In pre-1900 brassieres, linen, cotton broadcloth, and twill weaves were favored. “Whirlpool,” or concen-

tric, stitching shaped the bra structure of some designs after 1940. As man-made fibers were introduced, these were quickly adopted by the industry because of their properties of easy care. Since a brassiere must be laundered frequently, this was of great importance. Zippers were used in some designs, as well as Velcro, but these fasteners caused discomfort or caught on clothing and complicated laundering.

Small, medium, and large companies were making brassieres in America during the 1930s and 1940s. Some fell prey to shortages of material during World War II, others to changes in business practices in the drive for export markets. There were union problems, and in later decades challenges switching to computer-aided design. The need to supply and advertise to a nationwide market stretched some firms to the breaking point. Offshore production was initiated to save labor costs following the war, eroding influence of garment workers’ unions. Introduction of self-service in lingerie departments was another cost-cutting measure, but did not stem the loss of declining brands. Individual brand-name manufacturers have been taken over by conglomerates, which resulted in fewer available designs and less attention paid to quality, in part due to manufacturing processes being moved offshore. Brassiere manufacturing companies like Kabo of Chicago and Kops of New York were in business from the 1890s until the mid-1960s. Many like G. M. Poix, Treo, Model, Dorothy Bickum, Van Raalte, and Lovable lasted fifty or more years, often run by successive family generations. Maiden Form (until 1948, when it changed to Maidenform) began production in 1922 as a direct competitor to the New York-based Boyshform Company, who made bandeau flatteners for the slim styles of the times. After being a leader in the industry and developing through their advertising campaigns one of the best recognized brand names in history, Maidenform continues eighty years later with a smaller market share. Familiar names like Olga, Bali, Exquisite Form, and Playtex played important roles in the brassiere industry but are now owned by conglomerates.

Eroticism is associated with breasts and brassieres, and brassieres do play a role in the fetish and transvestite dressing by males; however, the garment was designed with the female shape in mind. One prominent promoter of eroticism with a twist of humor was Frederick’s of Hollywood, who has been almost eclipsed in the early 2000s by the very market-savvy Victoria’s Secret Company. The latter has parlayed lingerie into an art form, taking eroticism from the boudoir to the front parlor in an upward thrust of lace. Décolletage, whether natural or enhanced by padding, is emphasized with the underwired push-up brassiere and by silicone gel in the cups. The metallic wire in many brassieres has been replaced by flexible plastic, perhaps in an attempt to increase comfort and durability. Brassiere designs have been adapted over the decades to fashions of backless dresses, open to the waist in center front, or completely

strapless. The Bleumette brassiere and other brands featured gummed cup-shaped supports to the breasts directly when both bandeaus and straps were eschewed.

In 1969, a planned demonstration by a group of feminists who protested the proceedings at the Miss America pageant in Atlantic City, to call attention to their cause resulted in the myth of bra-burning; however, no fire was ever lit, and participants claimed that the bra, high heels, cosmetics, and girdles thrown into the “freedom trash can” were to be a non-pyrotechnic display. The assembled press reported the incident in ambiguous terms, leading many to believe the fire had consumed the offending brassieres. A few more aggressive feminists urged the disposal of all bras; however the majority of American women clung to their familiar fashions, if not their personal comfort.

The elasticized knitted fabric bras introduced in the 1970s and 1980s are now widely worn by athletes and nonathletes alike as comfortable substitutes for the underwired wonders of this age. As female athletes doff their jerseys to reveal brand-name sports bras, few eyebrows are lifted. In the later decades of the twentieth century, the structured brassiere continued its popularity with the majority of women in the middle of the age spectrum, but the youngest and oldest have often either resisted or refused to wear them. Whether for reasons of comfort or personal choice, many women in the twenty-first century are choosing not to wear brassieres.

See also **Fasteners; Lingerie; Underwear.**

#### BIBLIOGRAPHY

- Banner, Lois W. *American Beauty: A Social History Through Two Centuries of the American Ideal, and the Image of Beautiful Women*. Chicago: University of Chicago Press, 1983.
- Boucher, Françoise, and Yvonne Deslandres. *20,000 Years of Fashion: The History of Costume and Personal Adornment*. New York: Harry N. Abrams, 1987.
- Cunnington, Cecil Willette. *The Perfect Lady*. London: Max Parrish and Company, 1948.
- . *Feminine Attitudes in the Nineteenth Century*. London: Heinemann, 1955.
- Cunnington, Cecil Willette, and Phillis Cunnington. *The History of Underclothes*. New York: Dover Publications, Inc., 1992.
- Ecob, Helen Gilbert. *The Well-Dressed Woman*. New York: Fowler, 1982.
- Ewing, Elizabeth. *Underwear: A History*. New York: Theater Arts Books, 1972.
- . *Dress and Undress: A History of Women's Underwear*. New York: Drama Book Specialists, 1978.
- Farrell-Beck, Jane, and Colleen R. Grace. *Uplift: The Bra in America*. Philadelphia: University of Pennsylvania Press, 2002.
- Flower, B. O. “The Next Step Forward; or Thoughts on the Movement for Rational Dress.” *The Arena* 6 (1892): 635–644.

Flynt, Olivia. *Manual of Underdressing for Women and Children*. Boston: C. M. S. Twitchell, 1882.

Gersheim, Alison. *Victorian and Edwardian Fashions*. New York: Dover Publications, Inc., 1981.

Lane-Clayton, Janet E. *Hygiene of Women and Children*. London: Henry Frowde and Hodder and Stoughton, 1921.

Newton, S. M. Health. *Art and Reason: Dress Reformers of the Nineteenth Century*. London: John Murray, 1974.

Payne, Blanche, Geitel Winakor, and Jane Farrell-Beck. *The History of Costume: From Ancient Mesopotamia through the Twentieth Century*. 2nd ed. New York: HarperCollins, 1992.

Steele, Valerie Fahnestock. *Fashion and Eroticism: Ideals of Feminine Beauty from the Victorian Era to the Jazz Age*. New York: Oxford University Press, 1985.

———. *The Corset: A Cultural History*. New Haven, Conn.: Yale University Press, 2001.

Treves, Frederick. *Dress of the Period and Its Relations to Health*. London: Hillman and Son, 1882.

Verbrugge, M. H. *Able-Bodied Women: Personal and Social Change in Nineteenth Century Boston*. Oxford: Oxford University Press, 1988.

Vicinus, M., ed. *Suffer and Be Still: Women in the Victorian Age*. Bloomington: University of Indiana Press, 1973.

Woolson, Anna G., and C. Hastings, eds. *Five Essays on Women's Health: Dress Reform, 1874*. New York: Arno Press., Reprint, 1984.

Colleen Gau

**BREECHES** Breeches are a man's bifurcated outer garment, covering the lower body from waist to knees or just below the knees. The term “breeches” is synonymous with any form of short pants or trousers and has been used to describe several types of men's lower-body undergarments and outer garments from classical Roman dress through the twentieth century. However, breeches as a fashion garment were standard everyday attire for European and American men from the sixteenth through eighteenth centuries (American men after 1565). The term comes from Middle English “breech,” which was originally the Old English word “brēc” or “brēc,”—the plural of “brōc,” a leg covering. The term “breech” also refers to the lower rear part—the haunches or the buttocks—of the human body. Related clothing concepts include breech-cloth or breech-clout, a short cloth covering the loins, also called a loincloth; and breeching, the archaic English term used to refer to the rite of passage in which young boys wearing skirts were dressed in breeches to signify reaching the end of childhood. The term “drawers” is also used synonymously with breeches when referring to a man's knee-length, loosely fitted undergarment of separate legs covering the lower body. However, “drawers” also refers to various women's undergarments that are constructed of separate legs attached to a waistband, especially after the eighteenth



century. In common usage today, breeches are essentially distinguished from trousers and pants by length.

### Origin and Early Types

Various lower-body undergarments made of linen for men have been referred to as breeches in the history of Western dress. These garments ranged from knee to ankle length and were made of diverse fabrics and by diverse construction techniques. For example, the *bracchae*, or long, shapeless trousers worn by northern European ethnic groups contrasted with the shorter, knee-length, and more-fitted leg coverings called *feminalia* worn by Roman soldiers and horsemen through the fifth century. By the end of the twelfth century, the masculine wardrobe included some form of knee-length, loosely fitted, natural-colored linen breeches or drawers called *braies* that were worn under tunics of varying length. The lower legs were left bare, covered by hose or long stockings of woven cloth, or wrapped with crisscrossed lengths of narrow bands like bandages (sometimes referred to as *chausses*, from the French, a type of lower-leg chain mail armor). Images throughout the Middle Ages show peasants and laborers working in fields or on building sites dressed only in baggy, natural-colored linen braies, sometimes tucked into brightly colored hose worn with short leather boots or shoes. Higher-status men wore longer tunics that completely covered the linen braies. Braies were held up at the waist or hips by wrapping with a cord or belt and images show them to have been thickly rolled over at the top. They appear to be simply cut and sewn to shape around the legs but open and widely overlapped down the front. The prevalent style appears to have been constructed of a wide, gathered width of fabric draped from front to back between the legs but left open down both sides and tied around the waist or hips or rolled over the top at the waist.

### Fifteenth and Sixteenth Centuries

As hose became longer and more fitted to the shape of the leg, braies also became shorter and more fitted, and by the fifteenth century they were no longer seen as part of the outer wardrobe. By the early fifteenth century, the two separate legs of a pair of hose were joined at the crotch by a tied overlap or a codpiece and attached for support to the bottom of the doublet (a short, close-fitting jacket) with laces called points. This body-dominant style became the primary form of men's lower-body covering through most of the fifteenth century, providing the under layer for a variety of outer garment styles and the expression of regional and decorative design features. In the first half of the sixteenth century, by the 1540s, the full-length style of men's hose was broken up into two or three different sections called stocks (upper and lower, or nether, stocks) and trunk hose. Nether stocks were tightly fitted, knitted stockings covering the lower legs, ending just below or just above the knees, and sometimes fitted with garters under the knees. They were

tied into the leg band at the bottom of the upper stocks. Images show peasants and laborers working with points untied between the upper and lower hose, their lower hose rolled over and falling below the calf. The upper stocks, also called canions, covered the thighs and upper legs and were sewn into or tied onto the bottoms of the trunk hose, which covered the lower torso from waist to hips or mid-thigh. Although trunk hose were short and sometimes barely covered the buttocks in back or upper thighs in front, they were full and appeared puffy. Many were padded and constructed with an elaborate codpiece in front, but the codpiece gradually diminished and disappeared after the mid-sixteenth century. Compared with the lower hose, trunk hose were a more substantial garment designed to match the doublet with all of the fashionable and complex slashings (patterns of deliberate cuts in garments, allowing contrasting linings to show through), panes (narrow strips of fabric sewn over a contrasting lining), and parti-colorings of each period. It is a variation of the trunk hose that became the man's outer garment most commonly known as breeches, which also varied in cut and fit. Like hose, trunk hose and early breeches were constructed with pairs of hand-sewn eyelets along the upper edge and were laced or tied to the doublet for support. It was not until the seventeenth century that breeches became a separate, "stand-alone" garment constructed on a waistband, no longer worn suspended from the doublet.

Through the remainder of the sixteenth century, trunk hose expanded, and numerous variations in length and shape were common. Styles called round hose included paned and heavily padded shapes that resembled a ripe melon or pumpkin, ending at or just below the hip. Round hose were shaped and padded with horsehair, wool fleece, cotton, or linen tow. One extreme style of trunk hose rarely seen outside Elizabethan court circles was so abbreviated they resembled a wide pad around the hips, worn with very tightly fitted lower hose. Pluderhose (or *pluderhosen*, from the German) were another variation of trunk hose that resembled a pair of open breeches. Cut full and long, to below the knee, they were constructed of an under layer of contrasting fabric that spilled out between wide bands or panes of heavier fabric.

Trunk hose were at their most exaggerated in the last two decades of the sixteenth century. Different styles of longer, fuller upper hose called breeches were also fashionable in the late sixteenth century. Variations of breeches included Venetians, which were a baggy garment that were quite wide at the waist and tapered to the knee or just below. They were slightly padded to hold their shape and were constructed with seams on both inner and outer sides of the legs. The fullness at the waist was controlled with wide, deep gathers or cartridge pleats. Voluminous breeches called galligaskins, gally hose, *gascoynes* (from the French), or slops (also *slopp* or *sloppe*, from the Dutch) were cut with extra width at the knees, maintaining a bulky appearance without padding.

They had a softer and more informal appearance, drooping slightly over the knees with the extra fullness gathered or pleated into a band just below the knee.

### Seventeenth Century

In the first quarter of the seventeenth century, the extreme and rigid shapes of trunk hose softened, and the full, longer breeches like Venetians and galligaskins were the predominant fashion. Many breeches were embellished with a row of ribbon loops or lace “ruffles” below the knees, called boot hose, to span the area between lower edge and boot top. Shorter styles of breeches were constructed with a wide fitted band over the knees or lower thighs also called canions. After mid-century, a shorter style called petticoat breeches or rhinegraves was most fashionable. There were two types, one bifurcated and one open, but both resembled a full wide skirt and many were heavily embellished with rows of ribbons at waist, hem, and side seam. Wide “flounces” of lace or ribbons over the knees were worn with some petticoat breeches. A flounce is a strip of fabric gathered along one edge and attached to the bottom of a garment, such as a skirt, that creates a ruffled effect.

As breeches became longer with varying degrees of fullness in the seventeenth century, the methods for attaching them to the doublet also changed. Earlier trunk hose and breeches were still tied to the doublet lining or waist with laces called points. Ribbon points tied in a bow through the outer waist of the doublet provided an important decorative feature in the early seventeenth century. By the 1620s, however, when breeches replaced trunk hose, they were suspended from the doublet by hooks-and-eyes. Large metal hooks sewn into the waistband of breeches were attached to hand sewn or metal eyelets on the inside of the doublet waist. By the early 1660s, breeches were no longer tied to the doublet at all, but were fastened instead at the waist with a button or strap and held up on their own by suspending them from a waistband around the body’s waist or tying them tightly around the waist with a cord gathered through a sewn channel. Breeches were constructed with a lining, and the center front opening was buttoned up or tied closed. Linen breeches or drawers were also worn as an undergarment with breeches.

### Eighteenth Century

By the end of the seventeenth century, breeches were quite simplified in shape and trim, slimmer and more fitted to the shape of the legs, but still cut with fullness in the seat, or over the hips and abdomen. They had a cuff or band that fastened just under the knee and were worn with separate stockings that rolled up over the knee. Throughout the eighteenth century, the fit and details of breeches changed as the style of coat and waistcoat changed. During the first two decades, breeches were virtually hidden under the knee-length vest and coat of the three-piece suit, and a somewhat baggy fit did not mat-

ter. As coats were cut away after mid-century, breeches became very slim and fit closely over the thigh and knee. As breeches became slimmer, they were cut on the bias to give movement to tightly-fitted thigh and seat areas. Knee-band closures included narrow cuffs with buckles, buttons, or ties. After 1730, as waistcoats shortened, the front of the breeches over the abdomen was more visible. For a smoother appearance, the buttoned-fly front changed. Breeches were closed down center front with a “fall,” a large square flap five to eight inches wide, that buttoned to the waistband to cover an open fly. The center-front buttoned fly remained a less fashionable alternative to falls.

Breeches reached the end of their fashionability as standard men’s garments by the early 1790s. Two other alternatives were gaining prominence, and the term “knee breeches” was used to distinguish them from pantaloons and trousers. Trousers were practical, ankle-length, loosely fitted bifurcated garments closely identified with the working class. In France, the combination of knee breeches and silk stockings was called *culottes*, and it was this elite style seen in such sharp contrast to the working class trousers that identified the French revolutionaries as *sans culottes*. Pantaloons were a type of longer, closely fitted men’s day-wear breeches that fit into the top of riding boots. They became a very fashionable alternative to trousers and were worn with a strap under the sole of a shoe to increase the effect of the clingingly tight fit.

### Nineteenth and Twentieth Centuries

During the first decade of the nineteenth century, fashionable young men preferred pantaloons or trousers while older generations continued to wear knee breeches. After trousers became standard everyday attire for men, breeches with a square front fall and diagonal side pockets were worn as riding breeches. By the 1890s, however, a specialized type of breeches was worn instead for horseback riding. The inside of each leg in these full-cut breeches was made with leather or suede, and tightly fitted wrappings for the lower leg were eventually constructed as part of this garment, creating the shape of the twentieth-century “winged” jodhpurs still used as riding dress. These late-nineteenth-century riding breeches were also worn by women, constructed with a detachable apron worn for modesty when astride a horse. Knee breeches were worn as the correct form of evening dress through the first decade of the nineteenth century and were worn with tailcoats as day-wear through the first quarter of the century. By the 1840s, the use of knee breeches was limited to British full ceremonial court dress. From the 1860s, the term “knickerbockers” was used to describe men’s knee breeches with loose, baggy knees and a knee-band fastened by a strap just under the knee. Knickerbockers were worn as informal country dress, with a sweater or Norfolk-style jacket, and for certain sports such as shooting or golf. An early-twentieth-

century style of knickerbockers known as “plus fours” were worn when hiking, biking, or playing golf. The name referred to the four inches added to their length to create an exaggerated overhang at the knee. Breeches were also used as livery for household servants such as footmen and chauffeurs in Britain and North America through the early twentieth century. In the twentieth century, a type of knee breeches was worn with leg wraps called puttees by some officers and troops fighting in World War I.

See also **Doublet; Hosiery, Men's.**

#### BIBLIOGRAPHY

- Arnold, Janet. *Patterns of Fashion: The Cut and Construction of Clothes for Men and Women c. 1560–1620*. London: Macmillan, 1985.
- Byrde, Penelope. *The Male Image: Men's Fashion in Britain, 1300–1970*. London: B. T. Batsford, Ltd., 1979.
- Chenoune, Farid. *A History of Men's Fashion*. Translated by Deke Dusinberre. Paris: Flammarion, 1993.
- De Marly, Diana. *Fashion for Men: An Illustrated History*. London: B. T. Batsford, Ltd., 1985.
- Payne, Blanche, Geitel Winakor, and Jane Farrell-Beck. *The History of Costume: From Ancient Mesopotamia through the Twentieth Century*. 2nd ed. New York: HarperCollins Publishers Inc., 1992.
- Tortora, Phyllis G., and Keith Eubank. *Survey of Historic Costume: A History of Western Dress*. 3rd ed. New York: Fairchild Publications, 1998.
- Waugh, Norah. *The Cut of Men's Clothes, 1600–1900*. New York: Routledge Theatre Arts Books, 1964.

Susan J. Tortore

**BROCADE.** See **Weave, Jacquard.**

**BROOCHES AND PINS** Brooches, pins, and fibulas can be defined within two overlapping categories of dress, as both functional and decorative items. Historically, they are primarily defined as utilitarian, as clasps and fasteners for use in closing garments on the body or in holding pieces of a garment together. They were also designed or used as personal adornment with ornamental features that communicate ideas about the wearer, and the wearer's period and milieu. The word “pin” carries the most broad and general usage that includes brooches and fibulas. However, fibula is most sharply defined within its historical usage while the meanings of pins and brooches have a much wider scope over time. The common element among all three is the more general fastening function of the pin. Historically, these fasteners did not have gendered associations, but in contemporary usage women wear brooches as purely decorative pieces of jewelry. In the early 2000s, while the word “brooch” could be used synonymously with “pin” as jewelry, pins were more com-

monly understood to be small, sharp, metal-wire fasteners called “straight pins” and used in sewing and tailoring processes, unless modified by a descriptive prefix such as in “hatpin.”

#### Pins

A pin is broadly defined as a straight, cylindrical piece of metal with a sharp point on one end and a blunt head on the other, used for fastening by piercing a piece of fabric twice. Throughout history and around the world, in their most simple shape and function, pins have been made in various sizes and from such diverse materials as bone, thorns, bronze, iron, brass, silver, and gold. The heads of larger, specialized pins used as elements of dress, such as hatpins, tiepins, and hairpins, have been elaborately decorated with gemstones and other jewelry techniques to create designs appropriate to their period. For example, long and elaborate hatpins secured European and American women's hats to their hair in the seventeenth and eighteenth centuries, and in the Victorian period through the 1930s. Combining materials such as glass, beading, gemstones, pearls, or various metals, these hatpins may be described as small, precious sculptures. In contrast, smaller straight pins with a flat head have been important as fasteners for women's dress. In the Renaissance, for example, a woman might have been pinned into her bodice, rather than laced or buttoned, for a tight, smooth fit.

In several periods of dress history, items such as aprons were pinned to a woman's outer garment. In the nineteenth century, in fact, the word “pinafore” was coined to describe the washable aprons pinned to the front of women's and girls' clothing to protect them from stains while working or playing. The kilt pin is a contemporary example of old-style pins worn to display one's ethnic identity. Plaid kilts from Scotland, Ireland, and Wales are fastened with a large, sword-shaped pin made from metal, horn, or wood and embellished with Celtic-inspired motifs or cultural icons such as the thistle. Kilt pins might also be decorated with a clan badge to display the wearer's ancestry.

#### Fibula

The fibula is defined as an ancient or classical period clasp for fastening garments with a simple pin, spring, and catch-plate mechanism. The structural design of a fibula resembles that of a modern safety pin in that the wire pin is extended from a small coil of wire on one end that acts as a spring or hinge. This allows the pin to be opened and closed numerous times without breaking. The coiled spring also puts the pin under tension and secures it in the catch-plate on the other end. This integrally hinged pin structure is technically called an acus. Because of their resemblance, the safety pin is often said to have developed from the fibula. However, it is a simple, functional, and very common mechanism that has been used for millennia in many forms.





**A Tibetan woman wears a large metal brooch on her shawl.** Brooches have long been worn as ornamental and functional pieces of jewelry. The designs, materials, and workmanship indicate the wearers culture, religion, and social or economic position. © CHRISTINE KOLISCH/CORBIS. REPRODUCED BY PERMISSION.

The most recognizable forms of ancient fibulae are the elaborately decorated, bow-shaped clasps of Greek, Etruscan, or Roman periods, with long thin sheaths covering the pin. Archaeological examples show they were made of gold, silver, and bronze and variously worked with filigree, enamel, repoussé, and granulation techniques, or embellished with gemstones. Several fibulae were required for Greek women to fasten the style of tunic called an Ionic chiton across her shoulders and upper arms.

A number of varieties of Byzantine, Anglo-Saxon, and Romano-British fibulae have been found. The use of fibulae declined as the rectangular, draped styles of clothing gave way to the cut-and-sewn tunics of the early medieval periods. Fibulae are seen in use again as translations of the Classical styles during the Renaissance in the fifteenth and sixteenth centuries. Small, jeweled clasps or the gold points called aglets or aiguillettes were pinned to hold paned or slashed fabrics together on the sleeves,

bodices, and doublets of fashionable upper-class garments.

In the early twenty-first century, pairs of large, worked-silver clasps are used by women of nomadic groups in North Africa to close their cloaks and wrapped garments. While the European word “fibula” is used to describe them, they are not called such in indigenous use. For example, in Morocco they are called *tizerzai*. These clasps do not resemble ancient fibulae in appearance or structure. One style is made with a long pin hinged onto an open circle so that it slides. As the pin is pushed through the fabric, the circle is turned and one end is caught under the pin to hold it firmly in place. These fibulae, as a form of jewelry, are important elements of women’s dress and reflect the wearer’s social status and wealth in terms of their size, weight, and amount of silver used, and in how elaborately they are worked.

If safety pins are seen as a direct descendant of the fibula, one example of their use from contemporary dress should be mentioned, specifically, the use of safety pins in body-art piercings by punk youth subcultures in the 1970s and 1980s. Safety pins, as common, inexpensive, throwaway items, brought vernacular antifashion statements into play. In the 1990s, these ideas were extended to embellishing torn garments with patterns of multiple safety pins in both street dress and popular fashion. High-fashion designers such as Gianni Versace and John Galiano, referenced these street styles and embellished many designs with safety pins.

### Brooches

A brooch is broadly defined as a large decorative clasp or pin, but it may be more specifically defined as a clasp with either a fixed pin attached to the back or a hinged pin and catch-plate on the back. The brooch has a long history as a functional clasp with great ornamental importance as a piece of jewelry. The body of a brooch can take many sizes and forms, and types of brooches can be based on specific shapes, such as bars, closed circles, rings, open or penannular circles, bows, knots, hearts, or crosses, or designed with more abstract forms. As with any piece of jewelry, the design, materials, workmanship, and forms of embellishment communicate many ideas about the wearer, and the wearer’s period as well as culture, religious, fraternal, or guild affiliations and social or economic position.

The style of brooches and design changes with cultural and fashion changes and trends. The ancient brooch was often the focal point of an ensemble. Early brooches were large and made from sturdy metals such as bronze or silver to secure heavy wool or leather cloaks. As such, they also represented one of the most important and valuable objects of material culture and were buried with their wearer. In the early Middle Ages, brooches were the most widely used form of jewelry for European ethnic groups such as Germans, Lombards, Franks, and Anglo-Saxons.

For all of these reasons, many ancient brooches have survived. European men and women in the tenth through thirteenth centuries wore a round brooch called a *fermail* or *afiche* to fasten their outer mantle or surcote.

Religious uses include the medieval pilgrim badges sold or given to visitors at a shrine. Made to meet different levels of expense, they were worn as evidence of a successful pilgrimage and as a protective charm. In the sixteenth century, these badges inspired a type of round brooch called the *enseigne*, pinned by Italian men on the upturned brim of their hats. By mid-century they were worn throughout Europe by both men and women. *Enseigne* were upper-class brooches made from gold, encircled by gemstones, with enameled designs or carved cameos in the center representing a biblical or patron saint's theme. Other specialized types of brooches include mourning brooches worn from the time of the Middle Ages in memory of a deceased loved one. In the nineteenth century, these preserved a lock of the beloved's hair behind a crystal or glass cover.

After the early twentieth century, brooches were primarily categorized as costume jewelry worn by women for decorative reasons. Late-twentieth-century trends included wearing brooches from folk or ethnic dress to denote ethnic identity or to display cultural heritage. For instance, a large, round brooch called the *solje* is considered the national jewelry of Norway. Its lacy filigree style is worked in silver, pewter, or gold and embellished with small, movable, concave metal disks that resemble a spoon bowl. It was originally worn in Norway, through the nineteenth century, as part of folk-dress ensemble by a bride, but by the early 2000s was worn by European and American women to show Norwegian heritage. Replicas of ancient Celtic brooches are also worn by men and women with plaid kilts and sashes from Scotland, Ireland, and Wales.

See also **Costume Jewelry; Jewelry; Safety Pins.**

#### BIBLIOGRAPHY

- Borel, France. *The Splendor of Ethnic Jewelry: From the Colette and Jean-Pierre Ghysels Collection*. Translated by I. Mark Paris. New York: Harry N. Abrams, 1994.
- Evans, Joan. *A History of Jewellery, 1100–1870*. London: Faber and Faber, 1970.
- Gregoriotti, Guido. *Jewelry through the Ages*. Translated by Helen Lawrence. New York: American Heritage Press, 1969.
- Hackens, Tony. *Classical Jewelry: Catalog of the Classical Collection*. Providence: Museum of Art, Rhode Island School of Design, 1976.
- Heaton, Harriet A. *The Brooches of Many Nations*. Nottingham, U.K.: Murray's Nottingham Book Co., 1904.
- Jereb, James J. *Arts and Crafts of Morocco*. San Francisco: Chronicle Books, 1996.
- Newman, Harold. *An Illustrated Dictionary of Jewelry*. London: Thames and Hudson Inc., 1981.

Tait, Hugh, ed. *Seven Thousand Years of Jewellery*. London: British Museum, 1986.

Susan J. Torntore

**BROOKS BROTHERS** The United States led a clothing revolution in the nineteenth and early twentieth centuries in which clothes went from being individually made to being mass produced and from class display to democratic dress. Brooks Brothers played a major role in this revolution.

Henry Sands Brooks was forty-five years old and a provisioner on seafarers and traders when he bought a property on the corner of Catherine and Cherry Streets in the thriving business district of lower Manhattan in 1818. Calling his business H. Brooks and Company, he was intent on a new career selling quality clothing to the gentry and prosperous businessmen. It was his innovative plan, according to an advertisement he ran in the local newspaper, the *Morning Courier*, that same year, “to have on hand a very large stock of ready-made clothing just manufactured with a due regard to fashion, and embracing all the various styles of the day.” “Ready-made” heralded the appearance of reasonably priced, mass-produced clothing that was one of the United States’ greatest achievements of the nineteenth century.

Through his readily attainable, mass-produced clothing, Henry Brooks became a great innovator and marketer for the democratization of society. “Ready-to-wear placed gentlemanliness within the reach of men who once inhabited the outer reaches of society, enabling them to subscribe to its tenets and tout its virtues” (Joselit, p. 79). It was the beginning of a great cultural shift.

After Henry S. Brooks’s death in 1833, the store was refurbished and enlarged by his sons—Henry Jr., Daniel, John, Elisha, and Edward—“Brooks Brothers” for the business in 1850. Manufacturing trends in mid-nineteenth-century America had begun to seriously encroach on the preindustrial world of made-to-measure clothing. The invention of the inch tape measure early in the century allowed for standardized patterns. The Wilson and Wheeler factory sewing machine, invented in 1852, was the first to be used in the clothing industry and marks the beginning of industrial methods in U.S. clothing manufacturing. As Brooks Brothers was both maker and merchant, it was able to take advantage of these inventions. The firm noted in the 1860s that an overcoat required six days of hand-sewing to make, but could be done with the help of machines in half the time (Kidwell and Christman p. 77).

Along with industrialization, population rose to 20 million by mid-century, and westward expansion increased rapidly after gold was discovered at Sutter’s Mill in 1848. Brooks Brothers advertised its ready-wear clothing to the “California trade” and reaped profits for its own expansion.

As Manhattan's business district began to move northward along Broadway, Brooks opened a new store, a large four-story building at Broadway and Grand Street in 1858, which moved to South Union Square in 1869. The Broadway store became the principal place of business for the firm during the Civil War, and it was from this store that many Northern generals—including Grant, Hooker, Sherman, and Sheridan—were outfitted. Brooks Brothers also made frock coats for President Lincoln, one of which he was wearing on the fateful evening he was assassinated at Ford's Theatre in April 1865. The Brooks label on the inside of the coat was embellished with an embroidered design of an American bald eagle holding in its beak a flowing pennant inscribed "One Country, One Destiny."

By the turn into the twentieth century, Brooks Brothers was on the verge of a golden age, the period from roughly 1900 to 1970. By 1900, the modern corporation, with a new managerial class emerged, and a third of the population was urban. The firm became the clothier to this new "white collar" businessman who embodied the corporate ideal in a tailored dark suit, white shirt (or at least collar), and discreet necktie, a standard civil uniform that "served to obliterate ethnic origins and blur social distinctions" (Kidwell and Christman p. 15).

Around this time, Brooks introduced its "natural" look suit for the modern businessman. Known as Sack Suit Model #1 from that day to this, the coat had a four-button, single-breasted front, narrow lapels, center vent, and little padding in chest and shoulders, and was accompanied by narrow, flat-front trousers. It was a decidedly understated silhouette and quickly became the look of choice for the Eastern establishment. Another innovation was to incorporate a Boys' Department" (a "University Shop came later), so that parents could educate their sons in the proper appearance.

Other introductions of the early 1900s, which anglophile John Brooks (grandson of Henry) brought back from vacations in Britain, included the button-down collar, the polo overcoat, Shetland sweaters, Harris Tweed sports jackets, Argyle and Fair Isle knits, and oxford cloth shirting. It was this relaxed, country house approach to fashion that endeared Brooks to so many young men of the period and paved the way for the "Ivy League" styling that commanded the lion's share of American men's wear design from the Roaring 1920s to the revolutionary 1960s. This youthful, slim, stylish, and collegially casual image is Brooks's contribution to the United States' sartorial canon.

In 1915, Brooks moved north again with other business firms and built a handsome new flagship store at 44th Street and Madison Avenue, in noticeable proximity to the Harvard and Yale clubs and the New York Yacht Club. In a few short years, the elegant Italianate ten-story building became a mecca of discreet finery for the commercial and professional world. When the troops came

home from the Great War in Europe in 1918, Brooks Brothers entered its second hundred years with a roster of customers that included politicians and generals, old guard bankers, nouveaux riches manufacturing barons, and film stars. Literary voices such as Hemingway, F. Scott Fitzgerald, and John O'Hara sang Brooks's praises in print.

The Brooks Brothers catalog now contained a wide variety of dress, casual, evening, military, and livery clothing. About 1920, a three-button sack suit was introduced and soon became the standard model. Other introductions, such as white buckskin oxfords and canvas tennis shoes with rubber soles, Panama hats, and corduroy sports jackets also became classics, renowned in prose and poetry, such as Jimmy Rushing's vibrant "Harvard Blues":

I wear Brooks clothes and white shoes all the time,  
I wear Brooks clothes and white shoes all the time.  
Get 3 "C"s, a "D," and think checks from home  
sublime.

In the 1930s and 1940s, several warm-weather fabrics were introduced into its tailored clothing line, each weighing considerably less than the typical twelve- to fourteen-ounce woollens men were accustomed to wearing in the summer. Cotton seersucker, madras, tropical worsteds, and rayon at a mere nine ounces or less, reduced the weight of a summer suit from over four pounds to less than three.

With the end of World War II, the United States assumed the mantle of leadership in the West, and significant advances in automated manufacturing technology began to provide a host of consumer goods to the public.

Brooks placed its imprimatur on the gray flannel suit as the democratic uniform of choice for America's businessmen, an image soon familiarly known by several names: the "Madison Avenue Look," the "Ivy League Look," and, of course, the "Brooks Brothers Look." Casual conservative clothing with a campus flair rose to major fashion importance, as demobilized soldiers went to college with government loans on the G.I. Bill. Bermuda shorts, colorful plaid sports shirts, odd trousers, argyle hose, and penny loafers, all endorsed by Brooks, began to appear in men's closets. Modern jazz musicians such as Miles Davis, Gerry Mulligan, and Dave Brubeck helped spread the word that Ivy League styles were "the coolest."

Ironically, just as Brooks Brothers was about to reach the epitome of its popularity, the company passed out of the Brooks family's hands. In 1946, Winthrop Brooks, the "president who had piloted Brooks through a depression and a world war" (Cooke p. 67), sold the firm to Julius Garfinkel and Company of Washington, D.C. Garfinkel's was the first of many owners to acquire it (Allied Stores Corporation in 1981, Campeau in 1986, Marks & Spencer in 1988, and Retail Brand Alliance in 2001).



In 1952, the chemical firm Du Pont chose Brooks to develop and market a wrinkle-resistant shirt fabric utilizing its Dacron polyester fiber, reasoning that Brooks had the reputation, prestige, and credibility to popularize the concept. The following year, Brooks introduced the “wash-and-wear” shirt, and a polyester-and-cotton blended poplin fabric suit in 1958. The era of Brooks influence reached something of an apogee when, in 1961, the very Eastern establishment-looking senator John Fitzgerald Kennedy of Boston—where there had been a Brooks Brothers store since 1928—was elected President. In 1960, the *New York Times* referred to Kennedy as “a model of Brooks Brothers perfection,” and his chosen cabinet comprised members of the Ivy League who favored Brooks-styled tweed sports jackets, club ties, and button-down shirts.

Perhaps the greatest clothing and sociological innovation of the postwar years for Brooks was the introduction of a Woman’s Department in 1976, to cater to the newly emerging professional woman. At the same time, a program of accelerated expansion increased the number of Brooks stores to twenty-six and aimed at putting a store in every major shopping mall in the United States. By 1979, the firm became a recognized international retailer with the opening of a branch store in Tokyo. The Brooks Brothers style of business dress—propriety, understated elegance, and comfort—now became a global fashion statement. European designers and manufacturers began to copy the look.

In 1992, the firm initiated a “Wardrobe Concept” program of manufacturing and marketing suits as separate pieces, a technique that gained favor with other manufacturers. It also instituted a new “Digital Tailoring” approach to custom-made garments, using an automatic scanner to enter the customer’s measurements into a pattern-producing computer. And, just a few years short of entering its third century, Brooks opened a large, new, more futuristic-looking store on Fifth Avenue in 1999.

However, the tide of popularity had been turning against Brooks for some time. First, the various owners of the firm seemed to be getting farther and farther away from Brooks’s sense of quality and style, and “Brooks regulars must have felt increasingly unwelcome at the front door” (Cooke p. 134). Many thought that the integrity was gone from the label and the company was doomed to a drifting mediocrity. Designers like Ralph Lauren, a former Brooks salesman, made heavy inroads. In 2001 the company was bought yet again, this time by Retail Brand Alliance. But RBA had the aim and goal of putting the “golden” back into the famous “Golden Fleece” Brooks logo. Guided by Claudio Del Vecchio, son of a successful Italian eyewear manufacturer, the firm has made cautious progress since 2001 toward regaining its prestige.

See also **Polo Shirt; Ready-to-Wear; Sports Jacket; Suit, Business.**

#### BIBLIOGRAPHY

- Boyer, G. Bruce. *Elegance*. New York: W. W. Norton and Company, 1985.
- Cooke, John William. *Generations of Style*. New York: Brooks Brothers, 2003.
- Hall, Lee. *Common Threads*. New York: Bulfinch, 1992.
- Joselit, Jenna Weissman. *A Perfect Fit*. New York: Owl Books, 2001.
- Kidwell, Claudia B., and Margaret C. Christman. *Suiting Everyone*. Washington, D.C.: Smithsonian Institution Press, 1974.
- Martin, Richard, and Harold Koda. *Jocks and Nerds*. New York: Rizzoli International, 1989.
- Zakim, Michael. *Ready-Made Democracy: A History of Men’s Dress in the American Republic, 1760–1860*. Chicago: University of Chicago Press, 2003.

G. Bruce Boyer

**BRUMMELL, GEORGE (BEAU)** George Bryan Brummell (or Brummel), most famously known as “Beau” Brummell, was born in Britain in 1778 and died in 1840 in France. His dress and demeanor established many of the canons of dandyism. Although he was not an aristocrat by birth, he rose in the ranks of Regency society (1795–1820) and belonged to the circle of the Prince of Wales, known as the Prince Regent, who became King George IV. His father was a civil servant and secretary to Lord North, though his grandfather was probably a valet. Brummell was educated at Eton and left Oxford at the age of sixteen when he inherited a sum from his father estimated to have been 15,000 to 65,000 pounds. He became a cornet in the Tenth Hussars, the Prince’s regiment, known as “the Elegant Extracts,” and was a captain by the time of his retirement from the military in 1798. He then began his life as a stylish gentleman in his houses in Chesterfield and Chapel Streets in London and was a member of Brooks’s and White’s on St. James’s Street, the most exclusive gentlemen’s clubs of his day in an elite founded on the principle of exclusivity.

Brummell lived above his means, but his association with the Prince of Wales and his personal sense of style and cutting wit assured him a privileged place among the fashionable set. Many anecdotes mythologize his life, and though there is speculation as to his possible homosexuality, he was never linked specifically with a man or a woman, which the writer Jules Barbey d’Aureville took as a sign of his narcissism. In the second decade of the nineteenth century he fell out with the Prince Regent, and his creditors became more insistent. On 16 May 1816 he left Britain for Calais, France, because of his mounting debts and spent his last twenty-four years as an impoverished exile in Calais and then in Caen, Normandy, where he finished his life in a sanatorium.

Brummell’s dress was austere and elegant. It was not flamboyant or extravagant but consisted of impeccably

clean linen and finely tailored clothes. As Captain William Jesse (who published his biography in 1886) noted and Robert Dighton's portrait of 1805 illustrates, "His morning dress was similar to that of every other gentleman—top boots and buckskins, with a blue coat and a light or buff coloured waistcoat. . . . His dress of an evening was a blue coat and white waistcoat, black pantaloons which buttoned tight to the ankle, striped silk stockings and opera hat." Although this description suggests that his attire was not extraordinary in the context of Regency society, Brummell's personal attention to detail, function, and cleanliness as well as the fine materials, rare craftsmanship, dignified bearing, and mastery of social etiquette required to maintain such a wardrobe set him apart. The casual equestrian origins of his dress challenged courtly protocol and heralded the pared-down simplicity of masculine attire in the later nineteenth and early twentieth centuries.

Even in his lifetime Brummell was becoming a figure of fiction. A wide range of anecdotes and sayings were attributed to him. Sir Edward Bulwer-Lytton satirized him in his 1828 novel *Pelham; or, The Adventures of a Gentleman*. Mr. Russelton, a thinly disguised Brummell figure, boasts that he employs three tradesmen to make his gloves: "one for the hand, a second for the fingers, and a third for the thumb!"

Brummell's reputation spread to France, where Honoré de Balzac fictionalized him in his *Traité de la vie élégante* (Treatise on the Elegant Life), first published as a serial in *La mode* in 1830. The most important French writing on Brummell is Jules Amédée Barbey d'Aureville's short tract of 1845 entitled *Du Dandysme et de Georges Brummell* (On Dandyism and George Brummell). It celebrates Brummell's dandyism as a spiritual achievement of the highest order and raises the dandy's status to that of the poet or artist. This text shifts the terrain of dandyism to a superior intellectual and philosophical ground. Later nineteenth-century texts highlighted the artistic nature of the dandy and his cultivation of both his environment and his dress as works of art. These literary interpretations preserved the heritage of Brummell through the nineteenth century and brought him, transformed, to twentieth-century audiences.

In the first half of the twentieth century, his life would be reenacted in new venues, in the theater and on the silver screen. The playwright Clyde Fitch was commissioned by the matinee idol Richard Mansfield to write a play based on Brummell's legend. *Beau Brummell* premiered on 17 May 1890 at the Madison Square Theatre in New York City, starring Richard Mansfield and Beatrice Cameron. An illustrated version of the play was published in 1908 and remained popular into the second decade of the century.

Three Hollywood films loosely based on Fitch's play were made in the first half of the twentieth century. The first, just sixteen minutes long and directed by and starring James Young, was released in 1913. The second film,

produced by Warner Brothers in 1924, was a star vehicle for John Barrymore. This lavish costume movie was released worldwide and was on the *New York Times* top-ten list of films in 1924. In 1954 MGM studios came out with an even more extravagant production. This version cast the swashbuckling hero Stewart Granger in the starring role, alongside Elizabeth Taylor and Peter Ustinov, who is wonderfully petulant as the Prince Regent. Although it was produced in America, it featured both British and American actors and drew on the talents of the celebrated British costume designer Elizabeth Haffenden, who worked in collaboration with Walter Plunkett on this film. Despite the British cast and costumes, this Americanized Brummell is presented as a social and sartorial reformer who leads Britain from outdated, luxurious aristocratic mores into the more democratic, industrial, and progressive era of the nineteenth century. This was the final cinematic version of the Brummell legend, which has found new currency in literary accounts, such as George Walden's essay and translation of Barbey d'Aureville's text, entitled *Who Is a Dandy?*

William Jesse referred to Brummell as "cool and impertinent." Brummell's self-mastery and calculated sense of cool, his rise to fame in Regency society, and his sartorial perfection are his hallmarks. His name has become synonymous with dandyism, and the plaque marking his house in Chesterfield Street reads simply and appropriately, "A Man of Fashion."

See also **Art and Fashion; Dandyism; Fancy Dress; Fashion, Theories of.**

#### BIBLIOGRAPHY

- Barbey d'Aureville, Jules. *Who Is a Dandy?* Translated by George Walden. London: Gibson Square Books, 2002.
- Bulwer-Lytton, Edward. *Pelham; or, The Adventures of a Gentleman*. 3 vols. London: Colburn, 1828.
- Fitch, Clyde. *Beau Brummell: A Play in Four Acts*. New York: John Lane, 1908.
- Jesse, Captain William. *The Life of George Brummell, Esq., Commonly Called Beau Brummell*. London: John Nimmo, 1886.
- Moers, Ellen. *The Dandy: Brummell to Beerbohm*. London: Secker and Warburg, 1960.

*Alison Matthews David*

**BURBERRY** Although overtly recognized by its trademark check of red, black, white, and camel, Burberry is principally renowned for its innovation in waterproof clothing, rather than for the design of the lining material that traditionally lies beneath the outer gabardine cloth. Yet such is the power of reinvention, that to many the reverse is true. Burberry as a company is a rare thing—a British brand of clothing and goods that has successfully held on to its traditions while being able to remold itself into a covetable luxury brand that competes in a worldwide market. Thomas Burberry's invention of waterproof gabardine cloth has ensured that the form of



**Burberry's chief executive officer Rosemary Bravo.** Bravo transformed the financially ailing company in 1997. Her decision to use the company's trademark check on the outer fabric of their famous raincoats, instead of on the lining material, marked the turning point for the company's bottom line. © REUTERS NEWMEDIA INC./CORBIS. REPRODUCED BY PERMISSION.

apparel his company sold became bound to his name, so that the definition of Burberry in the Oxford English Dictionary reads "a distinguished type of raincoat."

Born in 1835, Thomas Burberry opened an outfitters shop in Basingstoke in 1856 at the relatively young age of twenty-one. As an ambitious country draper, Burberry was inspired by metropolitan ideas of fashionable dress, but drew upon local examples of work clothing to develop his ideas. His starting point was a loose-fitting linen smock that farmers and shepherds wore all year-round. Noticing that it kept the workers cool in summer yet warm in winter, he found on closer inspection that the close weave of the fabric helped to keep out the wet, while the looseness of the garment allowed for the circulation of air without inhibiting movement. By 1879 Burberry had refined his prototype fabric from his own mill to a cloth woven from long-staple Egyptian cotton. It created a fabric that was waterproof, breathable, rip-resistant and crease-proof. Burberry termed it gabardine cloth, reviving an old

term for a loose coat or cloak. It soon came to the attention of motorists, travelers, and explorers who used the weatherproof overcoat, often referred to as a "slip-on," in all weather conditions. When supported on four sticks, many an intrepid Colonial knew its additional use as an impromptu bathtub.

With a London store opening on Haymarket in 1890 (it remains the company headquarters to this day), the company grew to include a wholesale division and shops in Paris and New York by the turn of the century. Ever ready to protect the interests of his business and its products, Burberry registered the logo in 1904 and the eponymous check in 1920 (it did not appear on the lining of the raincoat until 1924). Further, in 1932 the company pioneered the department-store concession devoted exclusively to the sale of Burberry's goods.

The British War Office in 1900 commissioned Burberry to design an overcoat to replace the heavily rubberized mackintoshes that were then standard issue.



The lightweight cotton raincoat designed incorporated D-ring belt clasps, straps, and epaulettes for better function in combat and it soon gained popularity when endorsed by Lord Kitchener. As the most suitable protection from the appalling conditions of trench warfare, it is the origin of what we now refer to as the trench coat.

In 1970, Burberry opened a New York flagship store on east Fifty-Seventh Street. With the resurgence of the luxury goods market in the last decade of the twentieth century, the financially flailing company appointed Rose Marie Bravo in 1997 from Saks, New York as Chief Executive whose responsibility was to revive the brand. According to a story in the *Daily Telegraph*, her American friends dismissed her new job as “selling raincoats in London,” but within five years the value of the company rose from £200 million to £1.5 billion (\$350 million to \$2.67 billion). The linchpin of this transformation was the decision to use the check of the lining on the outer gabardine cloth of the raincoat in the first collection shown at London Fashion Week for A/W 1999/2000. When the model Kate Moss was caught by the paparazzi wearing the raincoat in the street rather than on the catwalk, demand for the item was unparalleled. In being worn in such a casual way, the raincoat signaled a metropolitan savvy that claimed as much an understanding of the visual heritage of British clothing, as an understanding of fashionable taste.

Although credited to Roberto Menichetti, the first appointed fashion designer for the company, the fashionability of the item was influenced by the subversive ideas of American fashion designer Miguel Androver and British fashion designer Russell Sage, who had both flaunted the inside-out Burberry raincoat in their catwalk collections for A/W 2000/1. While Androver mined the cachet of the checked lining in terms of the selling of vintage goods and their reuse, Sage questioned the legal permissibility of appropriating registered goods, sardonically titling his collection “So Sue Me.” Later in the same year, Burberry commissioned Mario Testino to photograph their campaigns, astutely hiring Kate Moss as the chief model.

The allure of the check reached unprecedented heights: young mothers dressed their babies in checked bibs, hooligans wore Burberry scarves in tribute to the Casuals who wore them on football terraces in the 1980s, and even Cherie Blair, prime minister Tony Blair’s wife, once sported a handbag. Menichetti’s response to this popular exposure was to make the high-end Prosum range showcased in Milan even more directional, causing him to be replaced by Christopher Bailey in 2000, who brought a more commercial and digestible level of reinvention to the product range. To this end, the variation on a raincoat remains core to the company’s design repertoire.

From the water-logged trenches of military warfare at the beginning of the twentieth century to the swimming-pool terraces of the twenty-first century, the insatiable de-

mand for the Burberry bikini in 2001 indicates that the kind of water protection the company is now investing in may have diversified considerably, but it remains curiously consistent with Thomas Burberry’s sense of reinvention.

See also **London Fashion; Raincoat; Rainwear.**

#### BIBLIOGRAPHY

- Barrow, Becky. “£10m Ride from Bronx to Burberry’s.” *Daily Telegraph*, 24 June 2002.
- Ewing, Elizabeth. *History of Twentieth Century Fashion*. London: Batsford, 1974.
- Sudjic, Deyan. *Cult Objects: The Complete Guide to Having It All*. London: Paladin, 1985.
- Thornton, Phil. *Casuals: The Story of Terrace Fashion*. Lytham, U.K.: Milo Books, 2003.

Alistair O'Neill

**BURQA** The seclusion and veiling of women in the Near East apparently long antecedes the emergence of Islam in the seventh century C.E. Islam, however, gives it religious sanction and enforcement. The Qu’ran (Sura XXIV.31) directs women to “be modest, draw their veils over their bosoms, and not reveal their adornments” except to certain specified male relatives, slaves, eunuchs, women, and children. In practice, this has resulted in the system of *purdab* (literally, “curtain”)—the enforced seclusion of Muslim women and their concealment under special outer garments in any situation where they might encounter non-familial men. These garments have taken different forms in various parts of the Islamic world.

In Afghanistan, Pakistan, and other parts of the Indian subcontinent, they take the form of the *burqa* (in Afghanistan, called a *chadri*), a voluminous, tentlike outer garment worn by women and girls from earliest puberty on, covering the entire figure from head to foot. Worn whenever a woman leaves her home or may otherwise be in the presence of proscribed males, it makes her totally anonymous and effectively invisible, also concealing and restricting her movements and activities. Its origins are uncertain, but may be pre-Islamic Persian.

The burqa is held in place by a quilted, fitted cap, elaborately embroidered in the same color as the fabric; from this cap flow many yards of fabric, gathered with masses of pleating at the sides and back, creating a hunched look. A small panel of openwork crochet over the eyes permits limited frontal vision. The unpleated front panel is only waist length, allowing the woman to use her hands. In permitted circumstances, this section can be thrown back over her head, exposing her face; otherwise, she holds the long side panels together for complete, stifling concealment. The fabric may be lightweight cotton, rayon, nylon, or silk, in a subdued color—gray, brown, white, pale blue, or green (but unlike the *chador* in Iran and coverings in many Arab countries, not black);

with the goal being anonymity, no bright colors, patterned fabrics, or individualized ornamentation are used.

The burqa is primarily urban, a symbol of nonlaboring status, and may conceal fashionable modern apparel. (Instead of the burqa, village women, whose farm and household work would be hindered, wear long, loose, baggy shirts and trousers and a large head scarf that they pull across the face in the presence of men outside the specified family circle. Some nomad women do not cover their faces.)

Efforts to eliminate or at least modify the rules of *purdah*, including the wearing of the burqa, have historically had mixed success. In Afghanistan in 1929, a modernizing king attempted to ban the *chadri* by fiat, triggering his overthrow. Wearing a burqa remained mandatory until 1959, when it was quietly made optional and was rapidly discarded by many urban Afghan women, particularly educated women, who adopted simple head scarves, long sleeves, and below-knee-length skirts to meet the requirement of modesty.

No such organized reform effort occurred in Pakistan or among Indian Muslims, where the burqa remains customary, though some modern educated women have abandon it. The rise of radical political Islamism in the 1980s revived its universal use, voluntarily or under duress, in Islamist-dominated areas, such as Pakistan's North West Frontier Province and Baluchistan, and Afghanistan under the Taliban regime from 1996 to 2002.

*See also* **Islamic Dress, Contemporary; Middle East: History of Islamic Dress; Religion and Dress.**

#### BIBLIOGRAPHY

- Clifford, Mary Louise. *The Land and People of Afghanistan*. New York: J. B. Lippincott, 1989. Several black-and-white photos; text on women discusses the *chadri*.
- Klass, Rosanne. *Land of the High Flags*. New York: Random House, 1964. Black-and-white photos and text regarding the psychology of living under the *chadri*.
- Michaud, Roland, and Sabrina Michaud. *Afghanistan: Paradise Lost*. London: Thames & Hudson, 1980. Several fine color photographs show details of the burqa and *chadri*.

*Rosanne Klass*

**BURROWS, STEPHEN** Stephen Gerald Burrows was born on 15 September 1943 in Newark, New Jersey. He studied at the Philadelphia Museum College of Art from 1961 to 1963 and at the Fashion Institute of Technology in New York from 1964 to 1966. Perhaps most influential to the future career of this original American designer was his seamstress grandmother, Beatrice Simmons, who taught him to sew when he was eight years old. At an early age he discovered and delighted in the zigzag stitch that would become a signature. As a de-

signer, instead of hiding stitching, Burrows celebrated and exaggerated it by using contrasting thread colors. He used a close, narrow zigzag stitch to create his trademark fluted "lettuce hem." In an endless range of shapes and combinations Burrows placed bright contrasting colors of chiffon or knit fabrics in a single ensemble.

After having success selling pieces to friends, Burrows cofounded the O Boutique at Nineteenth Street and Park Avenue South in 1968. Attracting the countercultural luminaries that hung out at Max's Kansas City across the street, the shop and its proprietor gained a following, but Burrow's lack of business experience resulted in O Boutique's eventual closure. In 1970 Geraldine Stutz, president of Henri Bendel, gave Burrows a space in the workroom of Bendel's Studio, the small manufacturing part of the store, and Pat Tennant, the manager of the design studio, became an important mentor to the designer. Stephen Burrows World opened in the summer of 1970 on the third floor of the store, as a packed audience watched a fashion show set to disco music. Leather garments with nail-studded embellishments, midskirts, skin-tight sweaters, suede bags dripping with fringe, and Burrows's famous super bright jersey knits shown on ethnically diverse male and female models impressed audience and press alike.

Burrows's fluid, sexy separates are iconic of the individualist, confident woman of the 1970s. The "black is beautiful" philosophy of the 1970s was showcased through Burrows's use of African American models and his success as an African American fashion designer. More than any other designer of the 1970s, Burrows captures in his designs the vivacious energy of the disco scene. By 1973 he was at the top of the field, winning the prestigious Coty award, the highest honor in American fashion, which he was honored with again in 1974 and 1977. He was one of five American designers invited to show their clothes along with five French designers at a fashion spectacle at the Palace of Versailles in 1973. Influenced by his success and the lure of Seventh Avenue, Burrows moved out on his own that same year. With this move he lost the guidance and protection of Bendel's staff, however, and his business suffered due to poor management. Used to overseeing the details of his clothing line's production, he was unable to achieve the same quality utilizing mass-manufacturing processes.

From 1977 to 1982 Burrows relaunched a successful collection with Henri Bendel. He stepped out of the New York fashion world in 1982 when the mood in fashion was changing and the disco era was coming to a close. He relaunched a third time with Henri Bendel in 2002, when his now-retro fashions were once again in demand.

*See also* **Fashion Designer; Jersey; Leather and Suede.**

#### BIBLIOGRAPHY

- Bellafante, G. "A Fallen Star of the 70's Is Back in the Business." *New York Times*, 1 January 2002.

Butler, J. "Burrows Is Back—With a Little Help from His Friends." *New York Times Magazine*, 5 June 1977.

Morris, Bernadine. "The Look of Fashions for the Seventies—In Colours That Can Dazzle." *New York Times*, 12 August 1970.

*Dennita Sewell*

**BUSINESS CASUAL.** See **Casual Business Dress.**

**BUSTLE** Exaggeration of the feminine posterior has been a periodic theme in Western fashion for several hundred years. The pulled-back overskirts of late-seventeenth and early-eighteenth-century mantuas (loose-fitting gowns) emphasized this area, and pads or "cork rumps" sometimes supported the swagged-up styles of the late 1770s and 1780s. Even early-nineteenth-century neo-classical dresses often featured a small back pad—a so-called artificial hump—to give the high-waisted line a graceful flow. As waists lowered and skirts widened, the pad was retained, and by the late 1820s it was called a bustle. Throughout the mid-nineteenth century full skirts were enhanced by a small bustle made of padding, whalebone, or even inflatable rubber. In the 1870s and 1880s, however, both the skirt support and the silhouette created by the bustle became the focus of fashion.

In an age when men and women were considered to have distinct social roles, the late nineteenth century assumed the natural forms of the two genders also diverged. One arbiter of etiquette and aesthetics, "Professor" Thomas E. Hill, explained that, in contrast to the broad-shouldered male, the female figure is characterized by narrow, sloped shoulders but width across "the lower portion of the form." He stated that to avoid looking "masculine and unnatural," women's dresses should be tight on top while dressmakers are "permitted to arrange tuck and bow and flounce without stint below the waist." These enhanced derrieres proportionately lessened women's small waists, produced by corseting. The idea that women are naturally steatopygous or fat-buttocked is no more aberrant than the late-twentieth-century idea that all women should have "buns of steel."

The bustle, also known as a tournure, pannier, or dress improver, could be made in a wide variety of materials and shapes. Some types were full length, such as sprung steel half hoopskirts called crinolettes and petticoats with adjustable inset steels. Many bustles, however, were made to pad only the rump area, secured to the wearer by a buckled waistband. These could be simple rectangular- or crescent-shaped pads filled with horsehair or other stuffing, but more intricate forms included down-filled devices and puffed or ruffled constructions of crinoline or stiff fabric such as tampico hemp. Woven wire mesh bustles were advertised as not only cooler than padding, but uncrushable, eliminating the need for

furtive rearrangement after sitting. Other structures featured several metal springs arranged vertically, placed a large crescent-shaped spring horizontally below the waist, or had projecting steel half hoops that adjusted with lacing and claimed to cleverly fold up when the wearer sat down.

The material used to create bustles was seemingly endless: M. V. Hughes in her memoir *A London Child of the Seventies* (Oxford University Press, p. 84) recalls that an acquaintance used *The Times* newspaper to achieve her effective bustle, saying, "I find its paper so good, far more satisfactory than the *Daily News*." Petticoats, often with layers of ruffles down the back, helped smooth the line of the bustle pad and support bustled skirts.

By 1868, the fullness of women's skirts had moved to the back, and a bustle was needed to support fashionable puffed overskirts and large sashes. The high back interest continued in the early 1870s as the bustle gradually swelled in size. Although the back of the skirt remained the dominant feature, the silhouette slimmed down after about 1875, when the skirt and petticoats, drawn back low and close to the figure and usually flowing into a long train, were often unsupported by a bustle. In the early 1880s, the bustle returned in dramatic proportions, often forming a shelflike protuberance at right angles to the wearer's body. An examination of images of fashionable women in extreme bustle dresses would lead an impartial observer to conclude—as Bernard Rudofsky proposed in the 1940s—that skirts shaped in this peculiar way must contain a second pair of legs behind the women's normal ones.

The wardrobe of a woman of the time included a chemise, drawers, corset, corset cover, stockings, and several petticoats, as well as a bustle. The bustle's size was accentuated by all the features of fashionable dresses, including tight sleeves, tight-fitting bodices with back tails, and elaborately constructed skirts with back poufs, swags, gathering, pleating, draperies, and asymmetrical effects. While a few called for reform of feminine dress for artistic and health reasons, most accepted women's convoluted clothing as in accord with High Victorian taste, with its love of the ornate, ostentatious, and overdone. A fashionable woman, dressed in a horsehair or spring bustle, layers of undergarments, and rich, heavy fabrics trimmed with fringe, did present an upholstered effect, similar to an overstuffed sofa of the time, both expensive, decorative objects. In 1899, Thorstein Veblen's *The Theory of the Leisure Class* introduced ideas, such as the conferring of status by "conspicuous consumption," reflecting the bustle period's excesses. Yet to most contemporaries, highly contrived feminine clothing was not seen as contradictory to the spirit of this "age of progress," but rather as a concomitant of civilization, showing commercial enterprise and mechanical ingenuity and firmly establishing the "civilized" division of the sexes. Throughout the period, although ridiculed, the bustle silhouette was widely accepted and worn by women





**Women wearing bustles.** Bustles have been an element of Western fashion intermittently since the seventeenth century. Women's dresses were form-fitting on top and created with a tuck and flounce in the back, below the waist, to avoid appearing masculine.

© BETTMAN/CORBIS. REPRODUCED BY PERMISSION.

from all classes, as well as by little girls with their short skirts. As *The Delineator* noted in February 1886 (p. 99), some women did not wear a bustle pad, "except when such an adjunct if necessitated by a ceremonious toilette," relying instead on a flounced petticoat to support the drapery of simpler dresses.

After about 1887 the bustle reduced in size and skirts began to slim. The skirts of the early 1890s featured some back fullness, but emphasis had shifted to flared skirt hems and enormous leg-of-mutton sleeves, and bustle supports were not as fashionable. With skirts fitting snugly to the hips and derriere in the late 1890s, however, some women relied on skirt supports to achieve a gracefully rounded hipline that set off a small waist. While not as extreme as examples from the mid-1880s, the woven wire or quilted hip pads worn beyond the turn of century show the tenacity of the full-hipped female ideal.

Despite some historians' view that bustle fashions were surely the most hideous ever conceived, this very feminine silhouette has continued to fascinate. In the late 1930s,

Elsa Schiaparelli made playful homage to the bustle in some of her sleek evening dresses, while late-twentieth-century bustle interpretations by avant-garde designers, such as Yohji Yamamoto and Vivienne Westwood, have utilized the form with historically informed irony.

See also **Mantua; Skirt Supports.**

#### BIBLIOGRAPHY

- Blum, Stella. *Victorian Fashions and Costumes from Harper's Bazar 1867-1898*. New York: Dover Publications, Inc., 1974.
- Cunnington, C. Willett. *English Women's Clothing in the Nineteenth Century*. London: Faber and Faber, 1937. Reprint, New York: Dover Publications, Inc., 1990.
- Gernsheim, Alison. *Fashion and Reality: 1840-1914*. London: Faber and Faber, 1963. Reprint as *Victorian and Edwardian Fashion: A Photographic Survey*. New York: Dover Publications, Inc., 1981.
- Hill, Thomas E. *Never Give a Lady a Restive Horse*. From *Manual of Social and Business Forms: Selections*. 1873. Also from *Album of Biography and Art*. 1881. Reprint, Berkeley, Calif.: Diablo Press, 1967.

## BUTTONS

- Hughes, Mary Vivian. *A London Child of the Seventies*. London: Oxford University Press, 1934.
- Rudofsky, Bernard. *The Unfashionable Human Body*. New York: Doubleday and Company, 1971.
- Severa, Joan. *Dressed for the Photographer: Ordinary Americans and Fashion, 1840–1900*. Kent, Ohio: Kent State University Press, 1995.
- Waugh, Norah. *Corsets and Crinolines*. New York: Theatre Arts Books, 1954.

H. Kristina Haugland

**BUTTONS** Button-like objects of stone, glass, bone, ceramic, and gold have been found at archaeological sites dating as early as 2000 B.C.E., but evidence suggests that these objects were used as decoration on cloth or strung like beads. Nevertheless, they have the familiar holes through which to pass a thread, which gives them the appearance of the button currently known as a fastener.

Buttons can be divided into two types according to the way they are attached to a garment. Shank buttons have a pierced knob or shaft on the back through which passes the sewing thread. The majority of buttons are this type. The shank can be a separate piece that is attached to the button or part of the button material itself, as in a molded button. Pierced buttons have a hole from front to back of the button so that the thread used to attach the button is visible on the face.

Almost every material that has been used in the fine and decorative arts has been used historically in the production of buttons. Buttons exist in a variety of materials: metals (precious or otherwise), gemstones, ivory, horn, wood, bone, mother-of-pearl, glass, porcelain, paper, and silk. In the late nineteenth and twentieth centuries, celluloid and other artificial materials have been used to imitate natural materials.

### Early History

The precursor to the button fastener was the fibula, a brooch or pin used to hold two pieces of clothing on the shoulder or chest. The button began to replace the fibula at least by the early Middle Ages, if not sooner.

Buttons functioned as primary fastenings for men's dress earlier than for women's. This may be due to the fact that the women's, from the late Middle Ages into the twentieth century, was required to be tight and smoothly fitted. Lacings and hooks are better suited to providing the strong hold and smooth appearance necessary for tight-fitting garments.

One of the earliest extant pieces of clothing to show the use of buttons as fastenings is the pourpoint of Charles of Blois (c. 1319–1364). This new outer garment was fitted in the body and sleeves, with buttons used to

close the front and the sleeves from the elbow. At this point, however, men's lower garments (hose, and, later, breeches) were still fastened to their upper garments, or to an interior belt, by points (laces of ribbon or cord decorated with metal tips). These points with metal tips were often attached as purely decorative pieces to both male and female apparel.

There are records of buttons in documents relating to nobility during the late Middle Ages and the Renaissance. For example, Philip the Good, Duke of Burgundy (1396–1497) ordered Venetian glass buttons decorated with pearls, and Francis I of France (1494–1547) is said to have ordered a set of black enamel buttons mounted on gold from a Parisian goldsmith. These were obviously special buttons of the same quality as contemporary jewelry. Buttons of any material were generally round in shape and made of decorated metal or covered with needlework in silk or metal threads on a wooden core. The ball-shaped toggle button is probably the type of button that replaced the fibula as a fastening for cloaks, capes, and other outer garments. A sixteenth-century example exists in Nuremberg hallmarked silver, attached to a thin bar by a flexible chain link.

### The Eighteenth Century

The eighteenth century is considered the Golden Age of buttons by collectors, as the variety of styles, as well as the physical size of buttons increase dramatically. Men's coats required buttons at the front opening, sleeves, pockets, and back vents. Waistcoats and breeches were also fastened with buttons. The size of the button grows and the shape generally flattens during the course of the century, ending in the flat disk as large as 1.38 inch (3.5 cm) in diameter. The value of decorations on a man's ensemble during this period, composed of metal thread embroidery and jeweled buttons, could account for as much as 80 percent of the cost of the suit of clothes. Thus, luxurious buttons became an increasingly essential part of the expression of status in upper-class men's dress. In Denis Diderot's *Encyclopédie* (c. 1746) the creativity of button-makers is exalted, though for moralists costly buttons became one sign of excess in fashion.

The newly fashionable paste jewels (imitation gemstones) appeared in the 1730s and were used to create some of the most highly prized buttons of the nineteenth century. Georges Frédéric Strass, a Parisian jeweler, perfected techniques of making these glass jewels.

As the button evolved from a ball to a flat disk, another notable change in decorative technique was the use of the button as a palette for painting. Representational images became immensely popular in the second half of the eighteenth century and are related to the miniature portraits that were worn as pendants or pins during the period. Portraits and subjects like rococo genre scenes, historical events, tourist views, and architectural monuments were produced. An extraordinary set of French





**Women shop for buttons in London, 1953.** Buttons have been a mainstay of fashion since 2000 B.C.E. and continue to hold their place as an object of function and style. Buttons are created in a variety of materials, including metals, plastics, gem stones, ivory, horn, wood, bone, mother-of-pearl, glass, porcelain, paper, and silk. © HULTON-DEUTSCH COLLECTION/CORBIS. REPRODUCED BY PERMISSION.

portrait miniature buttons was made about 1790 and included portraits of personalities from the French Revolutionary period; each portrait was set in silver with paste-diamond border and the name of the sitter engraved on the back. Artists of note participated in the production of portrait buttons; Jean-Baptiste Isabey (1767–1855), a miniature painter and pupil of Jacques-Louis David, records that he painted decorative buttons at the beginning of his career.

By the second half of the eighteenth century, button making in Europe fell into two categories: French button production remained a craft tradition allied with other high-quality decorative arts, while the English button industry developed mass-production techniques. Probably the most influential of the new English technologies was the development of cut-steel buttons and accessories by the steel manufacturer Matthew Bolton (1728–1809) of Birmingham in the 1760s. Bolton's cut-steel or faceted



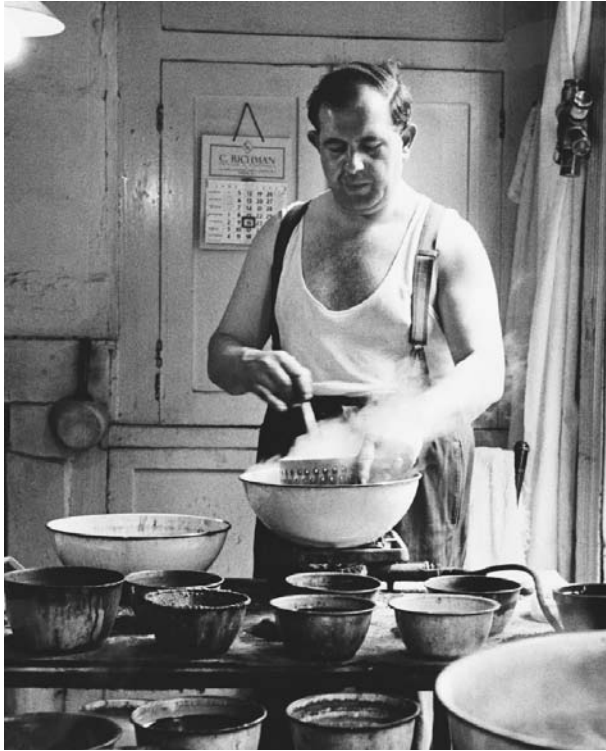

**Button dyer at work.** Buttons exist in a variety of colors and motifs and are a critical element in modern dress, as suit jackets and shirts are worn by white collar workers. © HULTON-DEUTSCH COLLECTION/CORBIS. REPRODUCED BY PERMISSION.

steel buttons were one of the most prevalent styles of the last three decades of the eighteenth century. The polished and faceted surface was created to imitate that of faceted gems or glass and the effect was quite successful.

The ceramic manufacturer Josiah Wedgwood began producing buttons made of his popular jasperware in 1773 as part of a collaboration with Matthew Bolton, who created cut-steel settings for the ceramic buttons. Jasperware ceramics, with their neoclassical motifs derived from cameos, had become the trademark product of the Wedgwood factory and the buttons were available in five colors and a variety of shapes. Another innovation in the ceramic industry, that of transfer printing, created a new type of ceramic button decorated with designs derived from copperplate engravings. At the end of the eighteenth century, buttons made from mother-of-pearl began to rival in popularity those of steel.

The eighteenth-century Enlightenment sensibility manifested itself in several unique types of buttons. Faithfully depicted insects and animals became the subject of button sets, as did buttons created from semiprecious materials such as agate, in which the natural patterns of the stones were the only decoration. The highlight of this natural history trend is probably the so-called Habitat

buttons, which contain actual specimens of insects, plants, or pieces of minerals encased under glass domes.

### Nineteenth and Twentieth Century

The standardization of military uniforms in eighteenth-century Europe led to the production of specialized buttons that continues to be a major portion of the button industry today. The number of buttons required for a soldier's coat could be as many as twenty to thirty. Each country, region, and specialization within the armed services required their own individual designs. Uniform buttons carried over into civilian life, as modern businesses, such as airlines, and local law enforcement agencies required special buttons for their uniforms.

Beginning in the early nineteenth century men's dress became much plainer and less ostentatious. Portraits by Jean-Auguste-Dominique Ingres (1780–1867) show men's fashion in the first half of the nineteenth century with plain gold metal or fabric buttons of the same color as the garment on which they are sewn. Women's bodices and outerwear became the outlet for the display of decorative buttons by the mid-nineteenth century. Women's buttons followed trends in jewelry: colored enamel, porcelain, pearl, silver, and jewels were used. Jet and black glass, introduced during Queen Victoria's mourning for Prince Albert, remained popular to the end of the century.

The nineteenth-century button industry continued along the two lines that had been established in the eighteenth century; industrial progress continued concurrently with handcraft techniques, which generally followed the historical revival styles of nineteenth-century decorative arts.

In 1812, Aaron Benedict established a metal button-making factory in Waterbury, Connecticut, to supply metal buttons for the military. Until that time many metal buttons were still coming from England, but the War of 1812 brought trade between the United States and Britain to a halt. As of 2003, Benedict's company, which became known as Waterbury Buttons, had been in business for 191 years. It is the oldest and largest producer of stamped metal buttons in the United States. Statistics from 1996 show that they produced 100 million buttons—about one-half for fashion trade and the remainder for military and commercial clients. Metal remains the main type of mass-produced button because the material lends itself to mass-production techniques.

The French firm Albert Parent et Cie, founded in 1825, exemplifies the brilliance of French manufacturers who combined mass-production techniques with the hand-finished details to produce luxury buttons in the manner of the eighteenth century. The company left an archive of sample books showing over 80,000 examples of buttons in every available technique of the time.

While more buttons were mass-produced in the nineteenth century that did not mean that fewer materi-

als were employed in the creation of buttons. Natural materials like horn and shells, which had been used for centuries, were rediscovered as mass-produced items. New materials such as celluloid, the first plastic, were used as early as the 1870s to imitate other materials.

Representational picture buttons, first introduced in the late eighteenth century, reached their peak between 1870 and 1914. The nineteenth-century scenes were generally mass-produced stamped metal designs depicting any motif imaginable, but contemporary marvels like the Eiffel Tower were especially popular.

The late nineteenth and early twentieth centuries saw more and more men and women wearing suits with linen or cotton shirts underneath, the new uniform for the emerging white-collar working class. Both suit jackets and shirts required buttons as fastenings and they created the need for large numbers of inexpensive buttons. Thus, the four-holed pierced button was introduced to both men's and women's fashions. However, fine jewelry quality buttons were still produced by some of the best-known retailers of the day such as Cartier, Liberty's of London, and Georg Jensen.

Buttons received competition in the form of the new zipper that was patented in 1903 but did not come into general use until the 1930s. The zipper was considered a novelty at first and played a prominent role as decoration in the designs of top designers.

Bakelite was invented in 1907 and by the 1930s had replaced almost all other synthetics for accessories. Durable and versatile, Bakelite was the medium for some of the most extravagant buttons of the twentieth century, but other plastics eventually replaced it. Three-dimensional accessories, such as fruit shapes, were created in the 1930s and 1940s when small accessories like buttons were especially popular. The designer Elsa Schiaparelli (1890–1973), who was allied with surrealist artists in the 1930s, is notable for her use of extraordinary custom-made buttons.

Plastics replaced most inexpensive glass and pearl buttons by the 1960s. That coupled with the fact that natural materials such as ivory and tortoiseshell are now

banned in the United States and other countries has led to the dominance of plastic buttons made to imitate these materials. Mother-of-pearl is still used but in much smaller quantities than in the past. American-made pearl buttons can cost from twenty-five cents to three dollars apiece, as some of the work must still be done by hand and the best shells are imported from the Pacific Ocean coastlines.

The use of stretch fabrics and increasingly informal dressing have led to a decrease in the demand for button fasteners. They have become a symbol of nostalgia and anachronistic tradition, as evidenced by retro button-fly jeans introduced by denim manufacturers in the 1990s and the continued use of rows of tiny buttons on the back of bridal gowns.

Buttons have become extremely collectible. The National Button Society exists for collectors and publishes a quarterly bulletin and holds an annual meeting and show. There are similar societies in Britain and Australia and elsewhere in the world. Military buttons represent a specialty among collectors, as the challenge of identifying the insignias of segments of the armed services adds to the interest of these items.

*See also* **Fasteners; Zipper.**

#### BIBLIOGRAPHY

- Boucher, Francois. *20,000 Years of Fashion: The History of Costume and Personal Adornment*. New York: Harry N. Abrams, 1987.
- DeMasters, Karen. "New Jersey & Co. Out of the Dust Emerge Lustrous Buttons." *New York Times*, 4 April 1999.
- Epstein, Diana, and Millicent Safro. *Buttons*. New York: Harry N. Abrams, 1991.
- Houart, Victor. *Buttons: A Collector's Guide*. London: Souvenir Press Ltd., 1977.
- Pearsall, Susan. "In Waterbury, Buttons Are Serious Business." *New York Times*, 3 August 1997.
- Roche, Daniel. *The Culture of Clothing: Dress and Fashion in the Ancient Régime*. New York: Cambridge University Press, 1996.

*Melinda Watt*



**CACHE-SEXE** The term “cache-sexe” refers to a covering for the female genitals. The term is derived from the French *cache*, which means to hide, and *sexe*, which means genitals. Other terms used synonymously are modesty apron, marriage apron, modesty skirt, loincloth, string skirt, and girdle. The choice of term appears to be related to the country of origin or discipline of the observer. In this case, “cache-sexe” appears to be the term used in those areas of the African continent that were colonized by the French, such as the region from western Mali to southern Cameroon. Cache-sexe are used throughout much of West Africa and parts of East Asia, where the term modesty apron is more commonly used. In short, a wide variety of terms are employed to describe an article of dress that offers insight into the life ways of women in some small-scale societies.

Cache-sexe are constructed of a variety of materials including woven fabric, leather, beads, leaves, and metals. For example, cache-sexe created by the Kirdi (Fulani) women in northern Cameroon are skirts beaded with a fantastic range of colors. Cowry shells and brass beads ornament and give weight to the fringe. Cowry shells originate in the Maldives, off the western coast of India, indicating Kirdi linkages to long distance trade. Cache-sexe are worn low on the hip and tied with a cord. Regardless of materials, the skirts measure approximately twelve to eighteen inches in length and twenty to twenty-two inches in width, excluding the cord.

The cache-sexe can be traced to the Paleolithic period, where stone carvings of fecund women, such as the Venus of Lespugue, depict panels of string fore and aft. String skirts dating from the fourteenth century B.C.E. have been uncovered in burial sites in Denmark. These skirts are wool, also ride low on the hip, fall to just above the knees, and wrap around the body twice. The cords of the skirt are thickly plied and knotted at the bottom, so that the skirt “must have had quite a swing to it” (Barber, p. 57). One of the oldest African examples of cache-sexe is described as a girdle from twelfth-century Mali. It can be described as a three-layer belt with very long fringes. The inner bark of the baobab tree is believed to be the source of the strands of fiber, which are plaited and twined into a solid chevron pattern. Its manufacture is closely related to the techniques used to produce snares,

nets, and baskets. This specific article of dress is significant because it was once believed that dress was introduced to sub-Saharan Africa by the spread of Islam. However, this object predates the expansion of Islam and is made of local, not imported, materials.

Cache-sexe appear to be exclusive to females. When and how a woman wears a cache-sexe varies from society to society. In some, a girl begins to wear the skirt after menarche; in others menarche is recognized by a change from a small leather panel skirt to a fringed skirt that wraps all the way around the body. In visual sources of information, cache-sexe are part of an ensemble that includes necklaces or supplements to the nose. In parts of New Guinea and Irian Jaya, women use knitted net bags that hang from a strap across the forehead. In twentieth-century images women can be seen wearing brassieres, T-shirts, and blouses.

Female informants report that protection from the environment is the main reason they wear cache-sexe. However, because of the open styling of the skirt, either as panels hanging in front and back or as fringes, it may be less effective as physical protection than as spiritual protection. For example, in Papua New Guinea, the Doni believe that ghosts can attack vulnerable areas like the anal opening. Articles of dress with ritual power, such as the cache-sexe, are used to protect, if not actually conceal, the lower body against evil.

Like the penis sheath, one function of the cache-sexe was thought to be modesty. A more likely interpretation of this act of dressing has more to do with fulfilling a group aesthetic about standards of public appearance. Not wearing a cache-sexe is a visible statement of a woman’s inability or unwillingness to participate in social interaction, as when ill or in mourning.

Indeed, the main function of the cache-sexe, like the penis sheath, appears to be one of drawing attention to the female secondary sex characteristics by intermittently concealing them. In her contemplation of Paleolithic string skirts, Barber states:

To solve the mystery of why they were [worn], I think we must follow our eyes. Not only do the skirts hide nothing of importance, but also if anything, they attract the eye precisely to the specifically female sexual



areas by framing them, presenting them, or playing peekaboo with them. . . . Our best guess, then is that string skirts indicated something about the childbearing ability or readiness of a woman, . . . that she was in some sense “available” as a bride. (p. 59)

Thus, the *cache sexe*, by any other name, is exclusively a female symbol. Like the penis sheath, it is more than a covering or a display. It is a unique form of material culture that draws one in to an understanding of the physical, social, and aesthetic life of women in some small-scale cultures.

See also **Penis Sheath**.

#### BIBLIOGRAPHY

- Barber, Elizabeth Wayland. *Women's Work: The First 20,000 Years*. New York: W. W. Norton and Company, 1994.
- Heider, Karl G. “Attributes and Categories in the Study of Material Culture: New Guinea Dani Attire.” *Man* 4, no. 3 (1969): 379–391.
- Hersey, Irwin. “The Beaded Cache-Sexe of Northern Cameroon.” *African Arts* 8, no. 2 (winter 1975): 64.
- O’Neill, Thomas. “Irian Jaya: Indonesia’s Wild Side.” *National Geographic* 189, no. 2 (February 1996): 2–34.
- Steinmetz, George. “Irian Jaya’s People of the Trees.” *National Geographic* 189, no. 2 (February 1996): 35–43.
- Symonds, Patricia V. *Calling the Soul: Gender and the Cycle of Life in a Hmong Village*. Seattle: University of Washington Press, 2003.

Sandra Lee Evenson

**CAFTAN** The term “caftan” (from Ottoman Turkish *qaftan*) is used to refer to a full-length, loosely-fitted garment with long or short sleeves worn by both men and women, primarily in the Levant and North Africa. The garment may be worn with a sash or belt. Some caftans open to the front or side and are tied or fastened with looped buttons running from neck to waist. Depending on use, caftans vary from hip to floor length. The caftan is similar to the more voluminous *djellaba* gown of the Middle East. Contemporary use of the label “caftan” broadens the term to encompass a number of similarly styled ancient and modern garment types.

The origin of the caftan is usually tied to Asia Minor and Mesopotamia. Caftan-like robes are depicted in the palace reliefs of ancient Persia dating to 600 B.C.E. By the thirteenth century C.E., the style had spread into Eastern Europe and Russia, where caftan styles provided the model for a number of different basic garments well into the nineteenth century (Yarwood 1986, p. 321, 62). The caftan tradition was particularly elaborate in the imperial wardrobes of the sixteenth-century Ottoman Empire in Anatolian Turkey. Caftans of varying lengths constructed from rich Ottoman satins and velvets of silk and metallic threads were worn by courtiers to indicate status, pre-

served in court treasuries, used as tribute, and given as “robes of honor” to visiting ambassadors, heads of state, important government officials, and master artisans working for the court (Atil 1987, p. 177, pp. 179–180.) Men’s caftans often had gores added, causing the caftan to flare at the bottom, while women’s garments were more closely fitted. Women were more likely to add sashes or belts. A sultan and his courtiers might layer two or three caftans with varying length sleeves for ceremonial functions. An inner short-sleeved caftan (*entari*), was usually secured with an embroidered sash or jeweled belt, while the outer caftan could have slits at the shoulder through which the wearer’s arms were thrust to display the sleeves (sometimes with detachable expansions) of the inner caftan to show off the contrasting fabrics of the garments (1987, pp. 182–198; p. 348). Loose pants gathered at the ankle or skirts were worn under the *entari*.

Caftan-style robes are worn in many parts of the world where Islam has spread, particularly in North and West Africa. In parts of West Africa, the practice of layering robes to express the aesthetic principle of “bigness” in leadership dress (Perani and Wolff 1999, pp. 90–95) and the giving of “robes of honor” is shared with the Ottoman tradition (Kriger 1988).

In Western culture, caftans became part of the international fashion scene in the mid-twentieth century. In the 1950s, French designer Christian Dior adapted the caftan style to design women’s floor-length evening coats (O’Hara 1986, p. 60). In the 1960s, the caftan as a unisex garment gained visibility as hippie trendsetters adopted ethnic dress. Largely through the influence of fashion maven Diana Vreeland, the editor of *Vogue* magazine, the caftan entered into the haute couture fashion scene. After a visit to Morocco in the early 1960s, Vreeland published a series of articles in *Vogue* championing the caftan as fashionable for “The Beautiful People” (Harrity 2003). Yves Saint Laurent and Halston were designers who included caftan-styled clothing in their lines (O’Hara 1986, p. 60). Since that time, caftans continue to have a market for evening and at-home wear for women and a more limited market with homosexual males (Harrity 2003). The caftan is now marketed globally as “fashion.” Contemporary designers draw their inspiration from a number of different historic traditions. For example, Hubert Givenchy draws upon the Middle Eastern tradition. African designers present the “dashiki caftan” based on West African prototypes. The J. Peterman Company markets a “Shang Dynasty Caftan” for women, copied from a Chinese silk ceremonial robe dated to 2640 B.C.E. In this globalization of the caftan, top Italian designers began marketing costly “designer caftans” in materials as diverse as silk and sheared mink to elite women of the Arab Middle East nations (*Time International*, Dec. 9, 2002).

See also **Djellaba**; **Iran: History of Dress**; **Middle East: History of Islamic Dress**.

## BIBLIOGRAPHY

- Atil, Esin. *The Age of Sultan Suleyman the Magnificent*. Washington, D.C.: National Gallery of Art; New York: Harry N. Abrams, Inc., 1987. Includes an excellent discussion of sixteenth-century imperial Ottoman caftans in the collection of the Topkapi Palace in Turkey.
- Kruger, Coleen. "Robes of the Sokoto Caliphate." *African Arts* 21, no. 3 (1988): 52–57, 78–79.
- O'Hara, Georgina. *The Encyclopaedia of Fashion*. New York: Harry N. Abrams, 1986.
- Perani, Judith, and Norma H. Wolff. *Cloth, Dress, and Art Patronage in Africa*. Oxford and New York: Berg Press, 1999.
- Stillman, Yedida Kalfon. *Arab Dress: A Short History from the Dawn of Islam to Modern Times*. Boston: Brill, 2000.
- Yarwood, Doreen. *The Encyclopedia of World Costume*. New York: Bonanza Books, 1986.

## Internet Resources

- Calderwood, Mark. "Ottoman Costume: An Overview of Sixteenth Century Turkish Dress." 2000. Available from <<http://www.geocities.com/kaganate>>.
- Harrity, Christopher. "Will You Know When It's Caftan Time?" July 25, 2003. Available from <<http://www.advocate.com>>

Norma H. Wolff

**CALICO** In the United States, the word "calico" refers to cotton cloth printed with tiny, tightly spaced, colorful motifs on a colored background. Because many people perceive it as pleasantly old-fashioned, calico has long found favor with quilt makers and it occasionally appears in children's wear. In the early twentieth century, instead of jeans or knits, women typically wore calico dresses and aprons to do housework.

Calico of the late 1500s was another matter. The Portuguese, intent upon being the first Europeans to trade for spices directly in the Malay archipelago, had arrived in Calicut, India. There they encountered colored and uncolored cotton cloths of all descriptions, which they designated generally as "calicoes." Perhaps by default, "calico" very gradually acquired a secondary meaning in reference to basic, unelaborated cottons lacking the distinctive characteristics of other ones like "dungaree" or "gingham."

**Calico in Early Commerce**

Centuries before European traders disembarked in India, a wide range of Indian calicos, including painted or printed ones called *chintees*, were carried by Arab traders to Turkey, the Levant, and North Africa as well as Southeast Asia. Through their Mediterranean trade connections, wealthy Europeans had enjoyed imported spices and Indian quilted silks. They knew—or desired—little of the cottons, although Armenian entrepreneurs managed a calico trade along with spices and silks.



## GLOSSARY OF TECHNICAL TERMS

- Madder:** Natural red dye obtained from the root of a Eurasian plant, *Rubia tinctoria*.
- Mordant:** A substance used in dyeing that helps to make the dye color more stable and permanent.
- Resist dyeing:** Any of a number of dyeing techniques in which part of the yarn or fabric is covered with some material that prevents the penetration of the dyestuff.

Early in their enterprise, Portuguese, Dutch, and English spice traders learned to appreciate cotton because the spice islanders would not sell their merchandise reasonably for anything other than their preferred Indian cloths—or opium. Thus enmeshed in calico trading, the traders sent quantities of the cheapest—probably leftovers—and some of the most luxurious kinds back home on private speculation or as curiosities. These generated a voracious European market; by the 1660s calico imports had become big business. Fine and heavy linens both could be replaced by the more affordable cottons; the *chintees* or prints were like nothing else.

English traders further expanded their operations by selling calicos to other companies that profitably exported them to Europe and the old-established Mediterranean and Levantine markets. They discovered lucrative markets in West Africa where, in the 1630s, they began selling special checked and striped calico as barter for slaves. The unsold remainders were sold in the West Indies for slave clothing and returned in the form of tobacco and sugar.

**Indian Chintees**

The processes of indigo resist dyeing and of applying mordants to selected areas of a cloth prior to dyeing in chay (madder) are thought to have originated in ancient times in India. The colored designs were not only brilliant, but fast, or laundry-proof—traits which riveted European imaginations and dollars. Common qualities looked crude because they were produced by the shortcut method of block printing, which also compromised the purity of the colors; printed calicos were inexpensive or downright cheap, and not cherished. The best goods, *kalamkari*, commanded a much higher price than printed ones, for they were hand painted—a time-consuming, laborious method that moved one exasperated entrepreneur to make remarks about creeping snails. These are the treasures that came to rest in museum collections.



**A designer arranges a calico dress on a model.** Calicos became so popular in France and England in the 1700s that both countries prohibited importing, printing, wearing, and using cottons in an effort to protect their own textile industry. © HULTON-DEUTSCH COLLECTION/CORBIS. REPRODUCED BY PERMISSION.

### Europeans and *Chinties*

European textiles had woven designs, manipulated surfaces, or applied decorations, and, apart from humble stripes and checks, these added significantly to the expense. They were difficult to maintain. Some handkerchiefs were printed with ink—not dye—to make handy city maps or other novelties that were not laundry-proof.

Dutch gentlewomen were pleased to wear India *chinties* but English ladies at first disdained them because the “meaner sort” already had embraced the cheap piece goods that first came along. By the 1660s, however, the upper classes in Europe and America were eagerly augmenting their wardrobes with washable banyans and other informal attire made of calicos custom-painted to



their taste. Everyone wanted *chintes* for the irresistible combination of eye-appeal, comfort, and launderability.

### European Printed Calico

When Europeans decided to try their own hands at printing in the 1600s, they printed on Indian calico. To eliminate the problems of dependence upon imported cloth, over the next century England led in developing machinery for cotton spinning and weaving. By 1800, Eli Whitney's American cotton gin enabled a steady supply of American raw cotton to busy mills. All the while, printing processes were becoming highly mechanized.

Because European designs were necessarily block printed—painting was too slow and tedious—the mordants required thickening. The trick was to concoct thickeners that gave clean imprints with minimal dulling of the colors. The development of better colors concerned all; mineral dyes and steaming were explored. Dye chemistry became a new field of research. In all aspects of calico manufacture, competition was fierce and industrial espionage rampant; production exploded.

### European Resistance to Calico

The path to commercial success was not straightforward. To protect its own textile manufacturers, France enacted a complex succession of prohibitions against importing, printing, wearing, and using *chintes* and cottons, effectively destroying its own opportunities from 1686 to 1759. In 1701, established English manufacturers got similar satisfaction, notably in the form of prohibitions against using, wearing, and importing calicos except for re-export. This was augmented twenty years later by prohibitions against using or wearing painted, printed, or dyed cottons made at home, with the exception of printed linens or fustians (linen warp with cotton weft) which were taxed. From 1774 to 1811, cottons woven with three blue selvage threads could be printed for export and a tax drawback obtained. Smuggling and subterfuge ensured that the market remained supplied; legal attempts to foil calico consumption were eventually abandoned.

Cotton and prints became accepted as facts of life. America gradually joined England, France, Holland, Germany, and Switzerland in the business of printing cottons. England surpassed its own reputation as the world's source of fine wools to become the world's source of plain and printed cotton cloth, exporting cheap cotton even to India by the 1840s.

Calicos are often made at least partly of polyester in the twenty-first century, and it may be safe to say that anyone who wears clothes has worn calico—a phenomenon founded on the ambitions of European spice traders to get to the pepper first. It could be argued that the industrial revolution happened in order to generate and supply a global appetite for calico. Machinery, chemistry, and transportation all tumbled into place seemingly to accomplish this purpose.



**An engraver puts a design onto a printing roller.** Hand-painted calico was very time-consuming and expensive to produce, and processes for printing and dyeing calico fabric were developed during the eighteenth and nineteenth centuries.

© BETTMAN/CORBIS. REPRODUCED BY PERMISSION.

See also **Chintz**.

#### BIBLIOGRAPHY

- Brédif, Josette *Toiles de Jouy*. London: Thames and Hudson, Inc., 1989.
- Irwin, John, and P. R. Schwartz. *Studies in Indo-European Textile History*. Ahmedabad, India: Calico Museum of Textiles, 1966.
- Irwin, John, and Katharine B. Brett. *Origins of Chintz*. London: Her Majesty's Stationer's Office, 1970.

Susan W. Greene

**CALLOT SISTERS** The Paris couture house Callot Sisters was founded in 1895 by four sisters, Marie Gerber, Marthe Bertrand, Régine Tennyson-Chantrelle, and Joséphine Crimont, at 24, rue Taitbout. The sisters came from an artistic family; their mother was a talented lace maker and embroiderer, and their father, Jean-Baptiste Callot, was an artist who came from a family of lace makers and engravers (including the esteemed seventeenth-century artist Jacques Callot) and taught at the *École nationale supérieure des beaux-arts*. Before opening the couture salon, the sisters owned a shop that sold antique laces, ribbons, and lingerie. Madame Gerber was generally acknowledged as the head designer and had worked as a *modéliste* (a designer who works under the house name but is not credited) with the firm Raudnitz et cie. By 1900 Callot Sisters was employing six hundred workers and had

clientele in Europe and America. The house's inclusion in the 1900 Paris Exposition Universelle, where it displayed dresses alongside such venerable couture firms as Doucet, Paquin, Redfern, Rouff, and Worth, demonstrates the sisters' respected place within the industry.

A number of designers, including Madeleine Vionnet and Georgette Renal, began their careers at Callot Sisters before launching their own couture houses. According to Vionnet, who worked at the house from 1901 to 1907, Madame Gerber was a friend of the art collector and critic Edmond de Goncourt, with whom she shared an interest in the Orient and eighteenth-century rococo design. The decor of the sisters' salon reflected these two influences, and they received their clients in a Chinese-style room adorned with Coromandel lacquer, Song dynasty silks, and Louis XV furniture. The house's design repertoire encompassed daywear, tailored suits, and evening dresses, but it was best known for its ethereal, eighteenth-century-inspired dishabille and exotic evening dress influenced by the East.

The sisters' luxurious tea gowns, produced in the early part of the century, were made of silk, chiffon, and organdy and often incorporated costly antique laces into their designs. Their penchant for such delicate materials prompted Marcel Proust to write, in *Remembrance of Things Past*, that the sisters "go in rather too freely for lace" (p. 675). Their layered, filmy, pastel-toned garments were very fashionable; such contemporaries as Jacques Doucet and Lucile also created such "confections," as they were often described.

In the 1910s and early 1920s the house's garments also drew upon the brilliant fauvist colors and Eastern-inspired design that were a vital part of the visual culture of the period. While this exotic mode is commonly associated with the designer Paul Poiret, the sisters also created clothing that incorporated embellishment and construction techniques derived from Asia and Africa. Some of these dresses (sometimes referred to as *robes phéniciennes*) integrated design elements from the two continents into one garment. For example, a kimono sleeve might be used with an Algerian burnoose form. Madeleine Vionnet recalls that the adoption of the kimono sleeve was Madame Gerber's innovation and that she was incorporating the cylindrical sleeve into art nouveau dresses in the early part of the century.

The year 1914 was significant for the design house, in that it marked both a move to 9–11, avenue Matignon and the sisters' involvement in Le syndicat de défense de la grande couture française. Through this organization, Callot Sisters, along with the designers Paul Poiret, Jacques Worth, Jeanne Paquin, Madeleine Cheruit, Paul Rodier, and Bianchini and Ferrier, put in place controls to protect their original designs from copy houses that sold them to ready-to-wear manufacturers without their permission. This is the period when the Callot Sisters, and many other designers, began to date their labels. While fashion activity in Paris subsided somewhat during World



"There are very few firms at present, one or two only, Callot—although they go in rather too freely for lace—Doucet, Cheruit, Paquin sometimes. The others are all horrible. . . . Then is there a vast difference between a Callot dress and one from any ordinary shop?" Albertine responds that there is a great difference because what one could buy for three hundred francs in an ordinary shop will cost two thousand at Callot soeurs (Proust, p. 675).

War I, the house of Callot remained open, and the sisters continued to promote their clothing in America by exhibiting at the 1915 Pacific Panama International Exposition in San Francisco, California. By the 1920s the house also expanded its operations to include branches in Nice, Biarritz, Buenos Aires, and London, further extending the international recognition of their label.

Callot Sisters remained active throughout the 1920s and participated in the 1925 Exposition internationale des arts décoratifs et industriels modernes in Paris, along with Jeanne Lanvin, the house of Worth, and the jeweler Cartier in the Pavilion of Elegance. By 1926, however, the fashionability of the house was on the wane. The American designer Elizabeth Hawes, who was working as a copyist in Paris in 1926, writes of dressing herself at Callot for some time and "getting some beautiful bargains in stylish clothes which lasted me for years. I had an extra fondness for Callot because the American buyers found her out of date and unfashionable. She was. She just made simple clothes with wonderful embroidery. Embroidery wasn't chic" (Hawes p. 66). The sisters retained their interest in fashionable detail and luxurious materials even when the more graphic lines of the art deco silhouette were in ascendance.

In 1928 Madame Gerber's son Pierre took over the firm and moved it to 41, avenue Montaigne, where it remained until Madame Gerber retired in 1937. At that time the company was absorbed into the house of Calvet, although labels with the Callot Sisters name appeared until the closing of Calvet in 1948.

See also **Art and Fashion; Haute Couture; Orientalism; Paris Fashion; Proust, Marcel; Vionnet, Madeleine.**

#### BIBLIOGRAPHY

- Chantrell, Maria Lyding. *Les Moires-Mesdames Callot Soeurs*. Paris: Paris Presses du Palais-Royal, 1978.
- Hawes, Elizabeth. *Fashion Is Spinach*. New York: Random House, 1938.
- Kirke, Betty. *Madeleine Vionnet*. San Francisco: Chronicle Books, 1998.

Milbank, Caroline Rennolds. *Couture: The Great Designers*. New York: Stewart, Tabori and Chang, Inc., 1985.

Proust, Marcel. *Remembrance of Things Past*. Vol. 2: *Within a Budding Grove*. Translated by C. K. Scott Moncrieff and Frederick A. Blossom. New York: Random House, 1927–1932.

Steele, Valerie. *Paris Fashion: A Cultural History*. New York and Oxford: Oxford University Press, 1988.

*Michelle Tolini Finamore*

**CAMBRIC, BATISTE, AND LAWN** From the early Middle Ages, the Low Countries had supplied Europe with superb linen fabrics. Among these was a thin, soft, notably white, closely woven, plain weave cloth called cambric after the Flemish city of its origin, Kambryk, now a French city called Cambrai. The French name for cambric, “batiste,” reputedly honors the first cambric weaver, John Baptiste. This specialty item was preferred for ecclesiastical wear, fine shirts, underwear, shirt frills, cravats, collars and cuffs, handkerchiefs, and infant wear.

At the same time, India had been exporting cottons to neighboring countries in the Near East, Africa, and to southeast Asia. Although trade between Europe and the Levant brought Indian quilted silks and Indonesian spices into northern homes, cotton apparently held little appeal. In the early seventeenth century, as a spin-off of their spice trade, the English and Dutch East India Companies gradually began importing into Europe various India cottons, from sheer *mulmulls* to brilliantly colored, painted *chintees*. The finer muslins presented increasingly stiff competition to cambric weavers because they were more affordable; the traders obliged, assisting the idea by grafting familiar linen names like “cambric” onto the Indian product.

Struggling to survive efforts to stymie their competition with domestic textile manufacturers, European calico printers undertook to produce their own calico (plain cotton) for printing, rather than depend upon Indian trade goods. The English had learned to make fustian, originally a worsted fabric, from linen and cotton. To comply with and transcend prohibitions against importing India cottons, some manufacturers succeeded in producing fustians that closely resembled the Indian original. This accomplished, manufacturers went on to master the skills of spinning and weaving very fine cotton yarns in imitation of the Indian muslins. Consequently, linen and cotton cambrics existed side by side in the nineteenth century along with “percales” and “jaconet” muslins, which were a bit denser. Flimsy, heavily sized cotton “lining cambric” came into use by the nineteenth century for lining lightweight clothes. It was too sleazy for outerwear, except for such things as masquerade costumes, and became limper still if dampened.

By the early twentieth century, cambric was known as a fine cotton characterized by a smooth, lustrous fin-



**Portrait of a Lady, by Rogier van der Weyden, circa 1435.** A thin, soft, closely woven linen, known as cambric and batiste, was produced in France. The cloth was used for religious apparel, fine shirts, and underwear. © BILDARCHIV PREUSSISCHER KULTURBESTZ/ART RESOURCE, NY. REPRODUCED BY PERMISSION.

ish. In the twenty-first century its original distinction of fineness has been all but lost, and polyester often displaces cotton. Modern uses for polyester cambric are much the same as the earliest ones. Blouses, thin shirts, summer dresses, infant clothing, pajamas, robes, and underwear are still made of cambric; sometimes it is possible to find items made of fine cotton, but ironically the fabric may well have been woven in India.

Another fine linen known as lawn after the French city of its origin—Laon—had characteristics very similar to those of cambric. Of the two, lawn was the most likely to be sheer. The earliest lawns often were woven with stripes, figures, or openwork in them, while cambric was not. Cambric, lawn, and batiste now are made virtually alike, of cotton or polyester in varying degrees of fineness. They are easily confused because they differ mainly in points of finish.

*See also* Cotton; Linen; Muslin.



## CAMEL HAIR

### BIBLIOGRAPHY

- Carmichael, W. L., George E. Linton, and Isaac Price. *Callaway Textile Dictionary*. La Grange, Fla.: Callaway Mills, 1947.
- Irwin, John, and P. R. Schwartz. *Studies in Indo-European Textile History*. Ahmedabad, India: Calico Museum of Textiles, 1966.
- Montgomery, Florence. *Textiles in America*. New York: W. W. Norton and Company, 1984.

*Susan W. Greene*

**CAMEL HAIR** The two-humped Bactrian camel furnishes the world with camel hair. Domestic Bactrian camels are an ancient crossbreed of the one-humped *Camelus dromedarius* of Syria and the two-humped, *Camelus bactranus* of Asia. The two camels were crossbred long ago to combine the heat resistance of the one-humped camel's fiber with the superior resistance to cold of the two-humped camel's fiber.

China produces the majority of the world's supply of camel hair, with the provinces of Xinjian and Inner Mongolia providing the most. The country of Mongolia is also a major supplier.

Each camel produces about five pounds of hair fiber per year. The fiber is double coated, meaning that it has one layer of long, coarse guard hairs, and an undercoat of soft, fine, downy fiber.

Camel hair is harvested in the spring of each year by shearing or by collecting the hair as it sheds naturally from the animals during their six- to eight-week molting season in the spring. In nomadic societies of years' past, a person called a "trailer" followed the camel caravan, collecting hair tufts as they dropped on the trail during the day and from the area where the camels had bedded down for the night. By the early 2000s shearing was done to increase the efficiency of harvest. The hair over the humps is generally left unshorn to increase the camel's disease resistance over the summer months.

The camel hair is roughly graded after it is shorn, then it is brought to herdsman's cooperatives and central distribution facilities for further sorting and grading. Only about 30 percent of the raw fiber is suitable for apparel products.

Camel hair's three grades are determined by the color and fineness of the fiber. The highest grade is reserved for camel hair that is light tan in color and is fine and soft. This top grade fiber is obtained from the camel's undercoat and is woven into the highest quality fabrics with the softest feel and most supple drape.

The second grade of camel hair fiber is longer and coarser than the first. The consumer can recognize fabric using the second grade of camel hair by its rougher feel and by the fact that it is usually blended with sheep's wool that has been dyed to match the camel color.

A third grade is for hair fibers that are quite coarse and long, and are tan to brownish-black in color. This

lowest grade of fibers is used within interlinings and interfacing in apparel where the fabrics are not seen, but help to add stiffness to the garments. It is also found in carpets and other textiles where lightness, strength, and stiffness are desired.

Under a microscope, camel's hair appears similar to wool fiber in that it is covered with fine scales. The fibers have a medulla, a hollow, air-filled matrix in the center of the fiber that makes the fiber an excellent insulator.

Camel hair fabric is most often seen in its natural tan color. When the fiber is dyed, it is generally navy blue, red, or black. Camel hair fabric is most often used in coats and jackets for fall and winter garments that have a brushed surface. Camel hair gives fabric warmth without weight and is especially soft and luxurious when the finest of fibers are used.

*See also Mohair.*

### BIBLIOGRAPHY

- Selomm, Boris. "Gaining an Insight into Camel-Hair Production." *Wool Record* (November 1985): 25, 29.

### *Internet Resources*

- Petrie, O. J. *Harvesting of Textile Animal Fibers: FAO Agricultural Service Bulletin No. 122*. Food and Agricultural Organization of the United Nations, Rome, 1995. Available from <<http://www.fao.org/docrep/v93843/v9384e00.htm>>.

*Ann W. Braaten*

**CAMOUFLAGE CLOTH** Camouflage cloth was developed during the twentieth century to make military personnel less visible to enemy forces. The word "camouflage" (from a French expression meaning "puffing smoke") refers to a process of evading visual detection through some combination of blend-in coloration, cryptic patterning, and blurring of the silhouette. Camouflage is widespread in the natural world, from the barklike coloration and patterning of many moths to the stripes of tigers and zebras. Used by predators and prey alike, camouflage is all about gaining a survival edge in situations of conflict.

Human beings have no natural camouflage features, but it is likely that some forms of camouflage have been used by humans for thousands of years. Prehistoric hunters would readily have learned to attach pieces of brush or clumps of grass to their clothing in order to approach prey undetected. In historic times, Indian hunters of the American Great Plains practiced a related technique, mimicry, by draping themselves in bison skins to approach herds of bison without alarming them.

The same techniques of camouflage that were employed by early hunters were applicable to small-scale tribal warfare and raiding. However, the development of large-scale military operations, which accompanied the

rise of civilization and the invention of metal weapons, made camouflage less important. Warfare for many centuries consisted largely of combat between forces in plain view of each other; camouflage has no role in an army of massed swordsmen or spearmen. Well into the nineteenth century, many armies wore brightly colored uniforms (such as the British redcoats) to aid in maintaining formations and to boost morale.

Armies fighting colonial and frontier wars, however, found such uniforms a disadvantage when dealing with irregular forces who fought from hidden places and employed time-honored camouflage techniques used in hunting and raiding. The development of improved firearms capable of accurate long-distance fire at individual targets also made it important for troops to make themselves less conspicuous.

During the nineteenth century, British military forces in India encountered khaki (Urdu for “dust-colored”) cloth, which they began to adopt for field use. Khaki uniforms were standard-issue for British troops in the South African Boer War in the 1890s, which featured widespread use of guerrilla tactics by the Boer forces.

Camouflage paint in various colors and cryptic patterns was used by German, French, and other forces during World War I to decrease the visibility of bunkers, tanks, and even ships, but camouflage was not widely used to protect troops during that war. In the 1920s, the French military conducted extensive research into camouflage, and other armed forces soon followed suit; camouflage cloth as such dates to the period between the two World Wars. During World War II, camouflage paint and netting were extensively used to disguise combat vehicles and forward bases, and troops on all sides used camouflage-cloth combat uniforms or tunics in some situations (including white outfits for winter, arctic, and mountain operations). A problem arose in that camouflage cloth made it difficult for troops to distinguish friend from foe under combat conditions. Partly for that reason, American soldiers in WWII largely abandoned camouflage gear except for their helmets, with netting covers into which twigs, grass, and leaves could be inserted.

American troops continued to avoid camouflage cloth in the Korean War, but camouflage gear became ubiquitous in military forces worldwide during the 1950s. Camouflage outfits were widely used by American troops during the Vietnam War, the Gulf War, and other operations. Patterns and color schemes have been continually refined to produce better results in different environments, including jungle, grasslands, and desert.

Camouflage cloth entered the civilian wardrobe in the late 1960s as part of the counterculture appropriation of military surplus clothing for street wear—an ironic response to the Vietnam War. The trend faded but then resumed in the street styles of the 1980s. In the 1990s, in the wake of the Gulf War, camouflage cloth (includ-

ing some pseudo-military patterns and colors developed especially for the civilian market) again entered civilian wardrobes. It was occasionally used even for such non-military clothing styles as sports jackets for men and dresses and skirts for women. In the second half of the decade, camouflage cloth was incorporated into the collections of several prominent designers, including John Galiano, Anna Sui, and Rei Kawakubo.

In the twenty-first century, camouflage cloth is firmly entrenched in the military wardrobe and continues to appear in civilian clothing from time to time. Though its military connotations are never absent, in some respects camouflage has become just another type of patterned cloth, like animal prints or plaid, available for optional use.

*See also* **Galiano, John; Protective Clothing; Uniforms, Military.**

#### BIBLIOGRAPHY

Newark, Tim, Quentin Newark, and J. F. Borsarello. *Brassey's Book of Camouflage*. London: Brassey's (U.K.) Ltd., 1996.

*John S. Major*

**CANES AND WALKING STICKS** A cane is a rod fabricated from wood, metal, plastic, or glass, used by individuals as walking aids, ceremonial or professional batons, or fashionable accessories. Some historians and collectors distinguish canes from walking sticks by materials, with the former constructed from bamboo and reed plants, and the latter from wood, ivory, or bone. Others distinguish on the basis of geographic linguistics—a cane in America is a walking stick in Europe.

#### Components and Materials

Most walking sticks and canes consist of a handle, shaft, and ferrules, one between the handle and the shaft to support the cane and conceal the juncture where the two meet, and one, at the bottom of the stick, to prevent wear of the shaft and to prevent splitting.

Wood is the most popular material for the shaft, and almost any kind of wood can be used—for example, chestnut, ebony, or beech. Naturally, the more expensive the wood, the more valuable the cane, and choice of material has historically helped to convey the status of the owner. For example, malacca wood, found only in the Malacca district of Malaysia, must be specially cultivated, and Irish blackthorn is a slow-growing wood that must be cut in parts and set aside for years to harden before it can be fashioned into a walking stick. Both types of canes are considered to be highly desirable for collectors. Other materials include ivory, bone, horn, and even glass. Metal and synthetic materials are also frequently used as orthopedic aids.

A cane's handle is traditionally decorative. Tops can be constructed from silver, gold, ivory, horn, or wood. They may also be fitted with precious gems.

### **The Many Uses of Canes**

Early canes probably originated as weapons of defense or as implements used for journeys over rough terrain. Pilgrims in the Middle Ages used them, as did bishops who traveled with sticks called crosiers. Less self-evident is the history and use of the walking stick for its alternative purposes of ceremony, fashion, or a badge of professional rank or membership.

Modern items such as ski poles, pogo sticks, and white sticks for the blind are based on prototypes of canes.

### **Ceremony**

Although in the early 2000s the cane is considered primarily an orthopedic aid, the ceremonial staff was present as early as Egyptian times.

In a historical context, ceremonial walking sticks and staffs have traditionally conveyed a sense of law and order to others. For example, in the fifteenth century, canes were important royal accessories. Henry VIII used a cane to symbolize British royal power. The cane has also functioned as a ceremonial token of military might. A short stick or baton was a favorite accessory for military officers in Europe between the eighteenth and early twentieth centuries. Canes were not only used in formal military dress but were also sometimes given to commemorate honorable service. It was thought that these canes bestowed confidence upon their owners, and British swagger sticks take their name from this thought. Ceremonial canes may also function as a badge of office or membership, and universities, political parties, and trade guilds adopted their usage for these purposes. The walking stick figures heavily into the official insignia of the medical profession. In the caduceus motif, a snake entwines around a walking stick, and this was modeled on the staff of Aesculapius. In Greek myth, Aesculapius's staff had the power to heal and thus symbolizes the godlike power attributed to the medical profession in modern times.

### **Fashion**

In addition to symbolic ceremonial usage, canes and walking sticks were also indispensable fashion accessories for men and women between the seventeenth and nineteenth centuries, used to display a sense of gentility and social propriety. During this period, canes could be distinguished by day and evening use, and it was assumed that an individual of good social standing would have a cane for every occasion, much in the way that women had an array of daily toilettes. Day canes were wide-ranging in their styles, and rare and expensive materials, ornamentation, and intricate decoration helped to express wealth and taste to others. While men's sticks were stately, women's sticks were often delicately accentuated with

ribbons or gilding. Evening sticks were more homogeneous in style. Traditional evening canes were usually made from ebony and were narrower and sometimes shorter than day sticks. Silver knobs or gold bands decorated ferrules and handles. These types of canes are those of popular imagination, featuring heavily into early twentieth-century Hollywood films.

### **Gadget Canes and Sword Sticks**

The gadget stick of the nineteenth and twentieth centuries emerged out of the fashionability of walking sticks. These were canes with an additional purpose; they contained secret items, such as snuffboxes, cosmetic compacts, picnic silverware, and later, radios; or the handle could convert into a seat, or the shaft was actually carved out as a flute. As their name conveys, people tried to top each other's canes of ingenuity and these walking sticks were a great fad.

Sword sticks, a popular item for military officials and dignitaries in the eighteenth century, operated in a similar way to the later gadget canes, although sword sticks were closer to the cane's original historic usage as a defense weapon, rather than for an adherence to fashion. These canes hid swords within their shafts and replaced the prevailing fashion for men to carry both swords and canes on their person. This trend lasted into the 1800s and spawned the development of other weapon sticks and gadget sticks for hunting and sport.

During their heyday, fashion canes, whether decorative or purposeful, were governed by specific rules and etiquette. One was not supposed to carry a walking stick under the arm, nor lean on it. Canes were also not to be used on Sundays or holidays, nor brought on a visit to a dignitary or member of the royal family, given the cane's connotation of authority and rank and its capacity to conceal a weapon.

### **Manufacturing and Retailing**

Canes and walking sticks have traditionally been sold through specialist retailers, such as mountaineering outlets and medical suppliers. Fashion canes were historically found at jewelers or shops that also sold umbrellas and sun parasols and still can be found there in the twenty-first century, although there are far fewer retailers than there were in earlier centuries. Many canes are also purchased through antique dealers, auction houses, or directly from the artisans.

### **The Decline of the Walking Stick**

Until the 1800s, specialist carvers, metal workers, and artisans produced canes and walking sticks by hand. However, the popularity of fashion and gadget canes fueled a market for their mass manufacture and subsequently helped lead to their demise. By the late nineteenth century, materials could be sourced globally and produced in volume for public demand. Canes became less artistic



and reflective of current fashions, and the modern crook-handled wood cane became the standard walking stick. By the turn of the century, walking sticks had become either novelty items or orthopedic aids. A London newspaper reported in 1875 how the usefulness of canes for many individuals had declined: “he needs not a help—he has no one to hit, and there is no one who will hit him; he needs not a support—for if he is fatigued, is there not the ponderous bus, the dashing Hansom, or the stealthy subterranean?” (Thornberry 1875).

Indeed, the visibility of canes and walking sticks as fashionable or ceremonial items declined more rapidly during the interwar period. The emergence of the automobile and public transportation and the fashionable popularity of briefcases and attachés rendered the cane less useful as a physical aid or storage device. It lost its traditional association with gentility, power, and authority, instead becoming a symbol primarily associated with the elderly or infirm.

See also **Europe and America: History of Dress (400–1900 C.E.)**.

#### BIBLIOGRAPHY

- Boothroyd, A. E. *Fascinating Walking Sticks*. London and New York: White Lion Publishers, 1973.
- Dike, Catherine. *Cane Curiosa: From Gun to Gadget*. Paris: Les Editions de l'Amateur; Geneva: Dike Publications, 1983. Good for gadget canes and the many purposes of walking sticks.
- Klever, Ulrich. *Walking Sticks, Accessory, Tool and Symbol*. Atglen, Pa.: Schiffer Publishing Ltd., 1984. Good for cultural history.
- Stein, Kurt. *Canes and Walking Sticks*. York, Pa.: Liberty Cap Books, 1974. A good overview of the accessory and its many uses.
- Thornberry, Walter. “My Walking Stick Shop.” In *The Pictorial World*. 3rd edition. July, 1875. In Gilham, F. Excerpts on fashion and fashion accessories 1705–1915, Volume VI: Umbrella and Walking Sticks 1766–1915, 1705–1915. This volume contains an extensive range of primary news cuttings and advertisements for walking sticks. Available from the art library at the Victoria and Albert Museum in London.

Leslie Harris

**CAPUCCI, ROBERTO** Roberto Capucci was born in Rome on 2 December 1930. He attended the Liceo artistico and the Accademia di Belle Arti di Roma, undecided as to whether to become an architect or a film director. He began designing clothing when he was still quite young and soon turned to fashion as his primary activity.

#### Early Career

In 1950 Capucci opened his first atelier on the via Sistina in Rome; in 1951 he presented his designs in a fashion show organized by Marchese Giovan Battista Giorgini in

Florence. On this occasion, Capucci showed overcoats lined with ermine and leopard, capes edged in dyed fox fur, garments of violet wool with brown and silver brocade—clothing that immediately won for him a loyal following. In reality, Capucci was still too young in 1951 to put together his own shows. The English-speaking fashion press referred to Capucci at this time as the “boy wonder” because he was not yet twenty when he opened his first atelier. Giorgini came up with a plan in which his wife and daughter modeled Capucci’s clothes during the show; the buyers literally went wild for the talented young designer. By 1956 Capucci was acclaimed as the best Italian fashion designer by the international press; that same year, he was publicly complimented by Christian Dior. In 1958 he was awarded the Filene’s of Boston “Fashion Oscar,” given for the first time to an Italian. Capucci was given the American award for his collection of angular clothing, which was part of his *linea “ascatola”* or “white boxes” project. The so-called box look was invented at the end of the 1950s by Capucci, to introduce the concept of architecture, volume, and project; an idea of tailoring related to the dress only. Consuelo Crespi was named the world’s most elegant woman wearing one of Capucci’s dresses.

In 1962 Capucci opened a workshop on the rue Cambon in Paris, a city he loved and where he was well received. He lived at the Hotel Ritz and was on friendly terms with Coco Chanel. Capucci was the first Italian designer asked to launch a perfume in France. After six years in Paris, Capucci returned to Italy permanently in 1968 and opened an atelier on the via Gregoriana in Rome, which became his headquarters.

#### Capucci’s Work in Costume Design

Capucci designed costumes for films and theatrical productions from the late 1960s through the 1970s. He believed that this experience was fundamental to his later artistic development. In 1968 Capucci designed the costumes for Silvana Mangano—in his opinion the most elegant woman he ever met—and Terence Stamp in Pier Paolo Pasolini’s film *Teorema* (1970). In 1986 he designed the priestess’s costumes for a production of Vincenzo Bellini’s opera *Norma* in the Arena di Verona, in “Omaggio a Maria Callas.” In 1995 Capucci was invited to China as a visiting lecturer in fashion design at the Universities of Beijing, Xi’an, and Shanghai.

#### Capucci’s Significance

Capucci is most often associated with haute couture, one-of-a-kind garments, and experimentation with structure. His garments are studies in volume, three dimensional in conception. His research followed both the abstract shape of geometry and the shape inspired by nature. He searched for an individual solution, a style, but he was primarily interested in the shape of the finished garment. He worked with meticulous attention to detail when designing a collection, preparing sometimes as many as a

thousand sketches, always in black and white to better evaluate forms and their metamorphoses and avoid being directly influenced by color. The preparation of a garment could require several months of work. Capucci used yards and yards of fabric, seeking out the most precious materials: taffeta, the softest satin, raw silk, mikado, georgette, and dyed silk from Lyon. It was not so much the rarity of the materials that interested him as the infinite possibilities for their use.

During the 1960s Capucci experimented with commonplace materials like raffia, plastic, straw, sacking, and Plexiglas. But throughout his career Capucci remained faithful to his primary interests—geometry, form, naturalism, and botany. The art critic Germano Celant wrote that his designs might be described by a historian as “soft medieval armor” (Bauzano 2003). Capucci traveled often and drew inspiration from his frequent travels. This influence was reflected in his designs or, as he described it, “the transposition to paper of emotions, ideas, and forms that I see around me when I travel” (Bauzano and Sozzani, p. 40). One of his favorite countries was India.

When ready-to-wear clothing and consumer fashion took hold in Italy during the 1980s in response to the demands of the marketplace, Capucci decided to withdraw from a system he considered unsuited to his way of working. In the beginning of the 1980s he resigned from the Camera Nazionale Della Moda Italiana, translated as the No Profit Association, which was founded in 1958 to discipline, coordinate, and protect the image of Italian fashion. Among other activities the Camera Della Moda is in charge of the organization of four events a year concerning prêt-à-porter: Milano Collezioni Donna (February–March and September–October) and Milano Collezioni Uomo (January and June–July). He decided to show his work no more than once a year, at a time and at a rhythm that suited him, often in museums, and always in a different city—the one that most inspired him at the moment. Clearly, Capucci was not part of Italian ready-to-wear design, a field from which he quickly distanced himself because he felt its logic of mass production was foreign to his creative needs.

Capucci was opposed to the “supermodel” phenomenon, which, in his opinion, obscured the garment, as did all other aspects of contemporary fashion. He preferred to make use instead of opera singers, princesses, the wives of Italy’s presidents, and debutantes from the Roman aristocracy. These women were called “*capuccine*” by the journalist Irene Brin. However, for more solemn occasions, he often turned to the famous and the beautiful: Gloria Swanson, Marilyn Monroe, Jacqueline Kennedy, Silvana Mangano, and the scientist Rita Levi Montalcini, whom he dressed for the Nobel Prize ceremony in 1986.

Capucci’s designs are often based on twentieth-century artistic movements: futurism, rationalism (the focus on pure shape for which he searched), and pop art. Referred to as the “Michelangelo of cloth,” Capucci

claimed, “I don’t consider myself a tailor or a designer but an artisan looking for ways of creating, looking for ways to express a fabric, to use it as a sculptor uses clay” (Bianchino and Quintavalle, p. 111). He considered himself a researcher more than a designer. His designs rarely seem to have dressing as their immediate goal. In this sense his creations can be appreciated for their intrinsic beauty and uniqueness. His designs are sculptural and architectural, which the body does not wear but inhabits; they are objects that blur the boundaries between art and fashion.

Capucci’s designs have been shown in the world’s leading museums, including the Galleria del costume in the Palazzo Pitti in Florence, the Museo Fortuny in Venice, the Victoria and Albert Museum in London, and the Kunsthistorisches Museum in Vienna. He has had many exhibitions of his work in Italy and around the world. In May 2003 the FAI (Fondo Italiano per L’ambiente) at Varese Villa Panza held an exhibition of Capucci’s work. Giuseppe Panza di Biumo wrote in the introduction to the exhibition’s catalog: “Capucci expresses his personality in a way that distinguishes him from everyone else. He is an artist in the fullest sense of the word, just as the painters who adorned their models with splendid garments.” In 2003 Capucci’s name became a brand, with a ready-to-wear line designed by Bernhard Willhelm, Sybilla, and Tara Subkoff, who have access to an archive of nearly 30,000 of Capucci’s designs.

See also **Dior, Christian; Italian Fashion; Paris Fashion; Perfume; Theatrical Costume.**

#### BIBLIOGRAPHY

- Bauzano, Gianluca, and F. Sozzani, eds. *Roberto Capucci: Lo stupore della forma, Ottanta abiti-scultura a Villa Panza*. Milan: Skira, 2003.
- Bianchino, Gloria, and Arturo Carlo Quintavalle. *Moda, dalla fiaba al design*. Novara, Italy: De Agostini, 1989.
- Gastel, Minnie. *50 anni di moda italiana*. Milan: Vallardi, 1995.
- Laurenzi, L. “Capucci.” In *Dizionario della moda*. Edited by Guido Vergani. Milan: Baldini and Castoldi, 1999.

*Simona Segre Reinach*

**CARDIN, PIERRE** During the last half of the twentieth century, Pierre Cardin (1922–) became a prominent and widely admired designer as well as a highly successful businessman. Cardin is known for his acute intuition, which often made him a trendsetter and design leader. Cardin has expanded his design operations far beyond fashions for both men and women to encompass all aspects of modern living. The name Cardin has become synonymous with his brand as he has expanded his commercial operations through timely licensing. As of the early 2000s, Cardin’s corporate empire held 900 licenses for production in 140 countries.



**Pierre Cardin displays his designs.** Cardin's fashion empire is known the world over. He is one of the first designers to "brand" his products, which include accessories and handbags, home interiors, luxury cars, and luggage. © REUTERS/CORBIS. REPRODUCED BY PERMISSION.

### Early Training

Born in Italy of French parents on 2 July 1922, the designer was originally named Pietro Cardini. After several years in Venice, however, his family relocated to France. As a young man Cardin briefly studied architecture before joining the house of Paquin in 1945. His tenure there gave him the opportunity of working with Christian Bérard and Jean Cocteau on the 1946 film *La Belle et la bête*, for which he created the velvet costume for the Beast, played by Jean Marais. After a brief stint with Elsa Schiaparelli, Cardin worked under the auspices of Christian Dior from 1946 until he went out on his own in 1950. Cardin honed his superb tailoring skills heading up Dior's

coat and suit workroom. Cardin's own business was first located on the rue Richepanse (renamed rue du Chevalier de Saint-George), but later moved to the famed rue du Faubourg Saint-Honoré, where the designer launched his first couture collection in 1953. In 1954 Cardin opened a boutique called Eve, followed by Adam for men in 1957.

From the beginning, Cardin showed himself to be an innovator and a rebel. He was quoted as saying, "For me, the fabric is nearly secondary. I believe first in shape, architecture, the geometry of a dress" (Lobenthal, p. 151). His experimentation with fabrics embraced geometric abstraction without losing sight of the human figure.





**Pierre Cardin minidress.** Cardin designed clothes that epitomized the mod look of the early 1960s, creating fashions with a minimalist look that featured clean lines and geometric shapes. This dress features the Cardin trademark bullseye. BULLSEYE MINIDRESS BY PIERRE CARDIN (c. 1965). GIFT OF LOIS WATSON. COURTESY OF THE TEXAS FASHION COLLECTION, UNIVERSITY OF NORTH TEXAS. PHOTO BY ABRAHAM BENCID, COPYRIGHT 1995.

Cardin's ability to sculpt fabric with an architectural sensibility became his signature. Making garments with impeccable craftsmanship, Cardin possessed the skills and vision to make his dreams a wearable reality. Even during the 1970s, when his dresses shifted from a sculpted look to a more draped silhouette, the fluidity of his work remained formal. Cardin was highly successful as a couturier, but he also sought to redefine the field of fashion design commercially. For his efforts in launching a ready-to-wear line alongside his couture collection, however, Cardin's membership in the prestigious *Chambre Syndicale* was revoked in 1959. Cardin was soon reinstated, but voluntarily resigned from the *Chambre* in 1966.

### Cardin's Men's Wear

Cardin's early training as a tailor's apprentice shaped his approach to fashion design for men as he matured throughout the 1950s. Cardin deconstructed the traditional business suit. He subtracted collars, cuffs, and lapels, creating one of the most compelling images of the

early 1960s. This look became instantly famous when Dougie Millings, the master tailor who made stage outfits for numerous British rock musicians, dressed the Beatles in his version of matching collarless suits.

Cardin's men's wear line was housed in a separate building on the Place Beauvau by 1962. He was inspired by his travels; after seeing the traditional high-collared jacket of India and Pakistan, he distilled its form into another popular innovation in men's fashions of the 1960s, the so-called Nehru jacket. Cardin further disrupted men's customary suiting by heralding the wearing of neck scarves in place of ties, and turtlenecks instead of button-down shirts. Yet he also was capable of designing men's clothing in the classic tradition, such as the costumes worn by the character John Steed in the British television series *The Avengers*.

### Space Age and Unisex Styles

Advances in fabric production and technology during the 1960s coincided with a widespread fascination with space exploration. Cardin's Space Age or Cosmocorps collection of 1964 synthesized his streamlined, minimal dressing for both men and women. This body-skimming apparel resembling uniforms featured cutouts inspired by op art. Cardin was innovative in his use of vinyl and metal in combination with wool fabric. Not just unisex, Cardin's clothing often seemed asexual. Unlike such other fashion minimalists as Rudi Gernreich and André Courrèges, Cardin did not promote pants for women. He often used monotone-colored stockings or white patterned tights to compliment his minidresses. The "Long Longuette," which was dubbed the maxidress, was Cardin's 1970 response to the miniskirt. In 1971, Cardin obtained an exclusive agreement with a German firm to use its stretch fabric, declaring that "stretch fabrics would revolutionize fashion" (Weir, p. 5). Continuing his reputation as a trendsetter, he showed white cotton T-shirts paired with couture gowns on the runway in 1974 and introduced exaggerated shoulders in 1979.

### Licensing and Global Marketing

Cardin learned much about the business side of fashion from his mentor Christian Dior. Dior had been very successful in trading on his name to license his designs internationally. Cardin took this approach further when he sought and found a global acceptance of his designs in countries as diverse as the Soviet Union, India, and Japan. Cardin was an exponent of what is now called branding long before other fashion designers followed suit. He was the first designer to sell ready-to-wear clothing in the Soviet Union as early as 1971. While Cardin's men's wear lines were ultimately more successful than his women's fashions in the United States during the 1970s, he still owned more than two hundred American retail outlets. Cardin was embraced by the Japanese market with special enthusiasm. At the peak of his expansion in 1969, Cardin boasted of having 192 factories throughout the world.



“The job of fashion is not just to make pretty suits or dresses, it is to change the face of the world by cut and line. It is to make another aspect of men evident.”

Pierre Cardin (in Lobenthal, p. 153)

Cardin’s fashion empire spanned the globe with his trademark licensing as of the early 2000s. Products identified by the Cardin brand ranged from accessories and handbags to home interiors, luxury cars, and luggage, as well as to such personal items as Fashion Tress wigs, introduced in 1973. The ubiquitous brand name was recognized around the world. As Caroline Milbank stated, “It is difficult to name something that Pierre Cardin has yet to design or transform with his imprint” (Milbank, p. 338). In 1971, Cardin transformed the former Théâtre des Ambassadeurs into L’Espace Cardin to promote new talent in performance art and fashion design. Cardin capitalized again on his fame in 1981 by purchasing Maxim’s, the famous Paris restaurant, and using its name to build a worldwide chain of restaurants in the mid-1980s.

### Brand Identity and Logos

During the early 1960s, Cardin was a pioneer in designing clothing conspicuously adorned with his company’s logo. This trend was picked up by many other designers from the 1970s onward. Cardin’s logos, consisting of his initials or a circular bull’s eye, were often three-dimensional vinyl appliqués or quilted directly into the garment. Cardin’s unrestrained licensing, while symbolic of his success, may have resulted in untimely diluting his name brand image.

Many fashion writers criticized Cardin for overexposure, especially given the very rapid expansion of his product lines during the 1980s and 1990s. Nevertheless, Cardin’s name was known throughout the world, and identified by the public with quality and high standards. Cardin stood out as one of the most complex designers of the twentieth century because he was one of a handful who understood that fashion is above all a business. His skills as an entrepreneur, and especially his creative licensing, made Pierre Cardin one of the richest people in the fashion world.

*See also* Brands and Labels; Dior, Christian; Fashion Marketing and Merchandising; Logos; Nehru Jacket; Paquin, Jeanne; Paris Fashion; Schiaparelli, Elsa; Space Age Styles; Unisex Clothing; Vinyl as Fashion Fabric.

### BIBLIOGRAPHY

Lobenthal, Joel. *Radical Rags: Fashions of the Sixties*. New York: Abbeville Press, 1990.

Lynam, Ruth, ed. *Couture: An Illustrated History of the Great Paris Designers and Their Creations*. Garden City, N.Y.: Doubleday, 1972.

Mendes, Valerie. *Pierre Cardin: Past, Present, Future*. London and Berlin: Dirk Nishen Publishing, 1990.

Milbank, Caroline Rennolds. *Couture: The Great Designers*. New York: Stewart, Tabori, and Chang, Inc., 1985.

Weir, June. “Cardin Today . . . A New Freedom.” *Women’s Wear Daily* (26 January 1971): 5.

Myra Walker

**CARICATURE AND FASHION** From the Italian for “charge” or “loaded,” the caricature print emerged in large numbers in the eighteenth century in industrializing western Europe. It was in the second half of the twentieth century that the caricature that concerned itself primarily with the subject of fashion and manners, rather than political or portrait themes, developed. The origins and conventions of the fashion caricature include overlapping literary, theatrical, and popular religious and artistic traditions. Greco-Roman theorizations, performances, and artistic depictions of the cosmic world turned upside down, and late medieval woodcuts, in which memento mori themes of the dance of death and the bonfire of the vanities established the tropes of the veneer of civilization and the futility of dress and cosmetics in arresting earthly time. The European carnival tradition, commedia dell’arte and puppetry, which highlight human foibles, and the figure of the hag who deploys fashion and makeup in an act of sartorial and spiritual delusion provided subjects for major artists working in the etching media such as Giambattista Tiepolo (1696–1770), Domenico Tiepolo (1727–1804), and Francisco de Goya (1746–1828). Not fashion caricatures as such, nor were these images widely available, but their themes recur in the eighteenth-century caricature print.

Caricature fashion prints also exist in a relationship to respectful engravings of the cries or occupations of the town, plates depicting national dress, and “costume plates” depicting courtier men and “women of quality” by seventeenth-century artists including Abraham Bosse and J. D. de Saint-Jean in France and the Bohemian Wenceslaus Hollar (1607–1677) working in England. The work of Jacques Callot (1592–1635) in France crosses the boundary between observation and satire. Etched images take on new meanings when pointed titles or moralizing verse are appended; the caricature generally makes use of a combination of word and image. Although censorship restricted production in France, prints were produced in neighboring Holland, and an early eighteenth-century fashion caricature entitled “The Powdered Poodle” survives in which the high-heeled shoes, forward posture, and long blond wig popularized by the court of Louis XIV is mocked in both image and appended verse (Paris, Bibliothèque Nationale).



**Man tight-lacing a woman's corset.** Caricatures began in Europe in the eighteenth century to depict social, political, national, geographic, and ethnic identity. New developments on the social, economic, and technological fronts were shown through exaggerated illustrations of clothing, dress, and mannerisms. © BETTMANN/CORBIS. REPRODUCED BY PERMISSION.

### Eighteenth-Century Caricature

Drawing on Renaissance physiognomic studies or “caprices” by Leonardo da Vinci, Giuseppe Arcimboldo, and Albrecht Dürer, and the baroque caricatures of Annibale and Agostoni Carracci (*Heads*, c. 1590) and Gianlorenzo Bernini, eighteenth-century Italy saw a rise in the production of recognizable portrait caricatures. They included carefully delineated costumes etched by Pier Leone Ghezzi (1674–1755) and Pietro Longhi (1702–1785), and painted in Rome by the English artists Sir Joshua Reynolds (1723–1792) and Thomas Patch (1725–1782). These works did not circulate widely in the public realm but were designed for the amusement of aristocratic circles participating in the Grand Tour who understood the dialectic of the ideal and the debased explored in this work. Furnishing their sitters with hideous physiognomies and ill-formed bodies loaded with fine clothing and airs, the works depict the dress and demeanor of the aristocrat abroad when the mask of civility has slipped under the influence of alcohol and other vice. The paintings of Patch and Reynolds drew upon the

painted “modern moral subject” and subsequent etching cycles produced in England by William Hogarth (*The Harlot's Progress* 1731; *The Rake's Progress* 1733–1734; *Marriage à la Mode* 1743). Cinematic in its scenic narrative, Hogarth's finely produced work included satirical details of fashionable dress and deportment that were used to emphasize more general political, aesthetic, and moral questions.

As new and cheaper forms of reproduction and literate audiences for periodicals and prints arose in Enlightenment western Europe, there was a marked increase in the output of satirical printmaking from the 1760s in France, Germany, and the Dutch Republic, but notably England. England's freedom of the press and involvement of the public in political and cultural affairs through coffeehouse, print, and exhibition culture encouraged the production of thousands of caricatures. Fashion had two principal functions in these prints. In the first half of the century, the English political print included dress to indicate class, political party, geographic, ethnic, and national identity. In tandem with theatrical precedents, the shorthand device for a Frenchman was elaborate court dress and a simpering posture, for a Spaniard a ruff, and a Dutchman round breeches. Nationalist Tories and the English John Bull figure wore rustic frock coats and boots, in contrast to the rich court dress of Whigs which resembled that of continental court culture.

In the second half of the century, numerous English printmakers who were also printsellers switched their output from political caricatures to social ones in which fashion formed the principal and not the secondary subject. Matthew and Mary Darly, John Dawes, William Humphrey, William Holland, Samuel W. Fores, Carington and John Bowles, and John Raphael Smith exhibited their wares publicly in shop windows and printed single sheet caricatures that were sold in folio sets, reproducing the designs of others such as John Collett, Robert Dighton, Henry W. Bunbury, and Thomas Rowlandson. Themes include the speed of new fashionable items, textiles, patterns, and bodily silhouettes; the alleged spread of fashionability to the lower orders including the servant class; the concomitant difficulty of reading the social sphere; themes of metropolitan urbanity versus rustic simplicity; the role of the appearance trades, such as wig-making and hairdressing, in promoting fashion; and alleged relationships between national fashions and character. The disjunction between the applied finery of fashion and the lumpen, deluded, or immoral physical body beneath continued older Christian themes.

The caricature print from 1760 extends the more general cultural association of women with extremes of fashion to that of men, as they scrutinize extensively the airs and dress of the macaroni (c. 1760–1780) and later the buck and the dandy (c. 1800–1820). Prints included both fictive and recognizable metropolitan individuals as well as referring to stock theatrical types such as the fop, the German friseur (an aged and ugly male hairdresser



whose physiognomy was interchangeable with the Jew), the dancing-master (French and effete), the rustic, and the Scotsman, a “Billingsgate Moll” (a market woman), and a “Lady of the Town” (prostitute). In the etched prints of Matthew Darly, the more lowborn the person depicted, the more crude the illustrative style, suggesting a cruder imitation or performance of fashionability. These differences perpetuate the belief that the orders are inherently either vulgar or superior depending on rank, as well as highlighting the joke contained in the overstepping of sartorial boundaries from class to class. Just as the development of caricature demands its opposite, idealized aesthetics, so the convoluted forms, surprising gestures, and novel departures of caricature perfectly reflected contemporary notions of the chicanery of fashion.

Caricature prints appeared in the expanding number of English periodicals, such as *The London Museum*, *The Oxford Magazine*, and *The Town and Country Magazine*. Sometimes hand-colored, many such prints were also sold or hired out in suites. Etching and engraving were the dominant techniques until the 1770s, when the mezzotint was developed and during the 1780s aquatint and stipple engraving appeared. The latter techniques permitted longer print-runs of more than one thousand and conveyed detailed messages about the texture of clothing and the tone of complexion. Carington Bowles’s and John Raphael Smith’s figures were also set in backgrounds such as paved streetscapes and neoclassical dressing-rooms and masquerade venues which comment on the spread of consumption, comfort, and new design novelties, including dress.

Caricature prints were relatively expensive, sought out by the aristocracy, the gentry, and collected even by the king. If generally too expensive for the artisan, prints were available for viewing in print shops, on the walls of taverns, coffeehouses, and clubs, or in the 1790s, visited in exhibitions. Satirical prints were generally kept in folios, and it is unclear how often they were glazed and hung. Pasted on walls they made “print-rooms” (Calke Abbey, Derbyshire) and ladies’ fans were occasionally composed of them. English prints were imported by French dealers and sent as far as St. Petersburg. Ambassadorial missions reported on their contents to rulers such as Louis XVI.

Although the circuits of exchange between English, French, Dutch, and German fashion caricature have not been clarified by scholars (most work has been done on revolutionary political imagery), it is apparent that the subject and style of English and continental work is interrelated. Hogarth derived much of his compositional virtuosity from a study of the French rococo fashion drawing and print by Boitard, Cochin, Coypel, Watteau, and Gravelot. The Matthew and Mary Darlys’ calligraphic linear style set upon evacuated white backgrounds was copied around Europe. A group of crude French engravings on the topic of fops, fashion absurdities, and touristic interactions in the street are virtually

indistinguishable in subject matter from English work, and the Darlys were copied in Germany. The French also produced caricature engravings of superb technical perfection and elegance in the 1770s, in which the style and format mocks both high fashion’s perfection and the engravings of manners seen in Rétif de la Bretonne’s *Monument du costume* (1789).

### Meanings of Caricature Fashion Prints

In Germany, Daniel Nikolaus Chodowiecki’s engravings for almanacs possess an elegant and animated line that epitomizes the ambiguity of some fashion caricatures. His paired contrasting images on the themes of artifice (court dress) and naturalism (neoclassical dressing) does not necessarily castigate the former: perhaps his suggestion is that pastoral dress is just as much an affectation for leisured peoples. His illustrations for Johann Kaspar Lavater’s highly influential study of character and physiognomy (1775–1778) with a considerable focus on dress, do function as explicit attacks on ancien régime manners and morals and argue that the new man must reject the set of the courtier.

Eighteenth-century prints were often reproduced in the nineteenth century without the context of their original verbal text banners. This led to different interpretations that were frequently sentimental and nostalgic. Approaches to the caricature reflect shifts in twentieth-century art-historical and social analysis. A reflection model used exhaustively by British Museum cataloger and historian M. Dorothy George analyzed caricature prints as representations of real events such as the launch and spread of a new fashion. This approach is reductive in that prints had multiple meanings to different audiences and may have helped create the dynamic of an event. Whereas the art historian Ernst Gombrich argued that the aim of the printmaker and dealer was to sell the product and not unsettle the purchaser overly, the Hogarth historian Ronald Paulson argued that within graphic satire a range of explanations are true and not mutually exclusive. Paulson argued that Hogarth’s work was designed for more than one audience and one reading. Like the theater, which assumed different reading positions from its multiple publics, the power of the caricature print is to function on several levels simultaneously. Although Brewer notes that there is almost no surviving evidence of how the common people viewed popular imagery, such as the caricature prints, there are many contemporary descriptions of the street and the theater, which emphasize that the fashionable and wealthy were often mocked or even abused for their pretension. Fashion caricatures participated in this dialogue.

Some men and women “of family and estate” such as W. H. Bunbury, Lady Diana Beauclerc, and the Marquis Townshend produced sketches which were engraved and distributed by professionals. Many of them laugh at the pretensions of the lower orders that emulate the manners and dress previously reserved for their social betters.

This is not the only meaning, however. As Maidment notes of the early-nineteenth-century “literary dustman” type, in form and technique such prints might simultaneously highlight the energy and ingenuity of laboring class subjects at the same time as mocking aspirational behavior. It partly explains the longevity of the caricature print in periodicals for all classes. Caricature fashion prints also provided information about the mood or set of a fashion such as the insouciance of the *Incroyable*, a fop of the Directoire period. As Anne Hollander noted of Renaissance art, forms such as engravings might teach people what it was to look fashionable. In the eighteenth century, high-art painting and caricature were both means through which fashion was read, experienced, and modulated.

### Nineteenth-Century Caricature

Master illustrators in the nineteenth century continued the themes on fashion laid down in the 1760s, notably Thomas Rowlandson (1756–1827) who worked for publisher Ackermann, James Gillray (1757–1815), Robert Dighton (1752–1814) and son Richard; Isaac Cruikshank (1756–1811) and sons Robert (1789–1856) and George (1792–1878). In the Revolutionary and Napoleonic period, dress featured as part of the textual jokes in political caricature. Respectful fashion plates and caricatures issued from the same hand of experienced illustrators: Jean-Francois Bosio (1764–1827) and Philibert Louis Debucourt (1755–1832), who deployed an extremely elegant style and fine coloring as part of the joke. In Paris the famed series by Horace Vernet, *Le Supreme bon ton* from *Caricatures parisiennes* (c. 1800) used the figure types and linear illustrative style of the contemporary fashion periodical, but distorted the figures, poses, and situations to expose the ludicrous nature of contemporary manners. H. Vernet provided “serious” fashion plates for Pierre La Mésangère, who was both the publisher of *Le journal des dames et des modes* (c. 1810) as well as the famous caricature series *Incroyables et merveilles* (1810–1818), which continued the work of his father, Carle Vernet (1758–1836), from the 1790s. The paradox and collisions of exoticism and historicism of early-nineteenth-century dress is extremely well conveyed in these French images. The series *Le bon genre* (French periodical 1814–1816) set English and French fashions side by side, subject to some distortion, in order to have a ready-made caricature that also provides fashion information and comments on national identity. Louis-Léopold Boilly’s exquisite painted genre scenes of fashionable life often verge on caricature with rather too much male and female buttock revealed through the chamois leather and muslin, and this interest was made explicit in his *Recueil de grimaces* (Paris, 1823–1828), caricature physiognomy lithographic studies.

### Nineteenth-Century Journalism and the Caricature

In the nineteenth century, reading publics and leisure time increased and the costs of printing decreased, with a massive expansion of cheap periodicals and news-sheets

including journals who now took the caricature as their very subject: in France *La caricature* (1830–1835) and its successor *Le charivari* (1832–1842) were run by Charles Philipon. Technical developments in lithographic, steel engraving, and wood-block reproductions meant that the caricature proliferated within these formats and ceased to be sold primarily within folio sets. When from 1835 political censorship was introduced in France, the caricature of Parisian manners became the screen through which other events might be filtered. Social, economic, and technological developments had major impacts upon fashion and there is no social topic in which the caricature did not participate. These included, but were not restricted to, male dandyism; the rise of the demimonde or courtesan class; sweatshops and the production of clothing; shopping and the department store; makeup and artifice; swells or dandies; middle-class hypocrisy and propriety; immodesty and the ball gown; women’s participation in sport and education; feminism and the suffragette movement; dress reform; emancipation and embourgeoisement of slaves; issues of class and the “servant problem”; the aesthetic movement of the 1880s; and the general spread of consumer goods. Extremes and novelties of fashion, such as the women’s crinoline and the bustle, the nature of fashionability and the *Parisienne*, and the interaction of the classes in the new public spaces of the metropoli of Paris, London, and New York, were delineated by highly accomplished artists working in lithography, notably Gustave Doré (1832–1883), J. J. Grandville (1803–1846), Joseph Traviès, Paul Gavarni (1804–1866), and Cham and J. L. Forain (1852–1931). Honoré Daumier (1808–1879) produced a massive output of 4,000 lithographs, many appearing in *Le charivari* and *Le Journal amusant*. His human comedy in which the same characters reappear relates to that of Balzac’s literature. Nineteenth-century caricature employed novel compositional formats with overlapping vignettes and asymmetrical strip formats, as seen in the periodical *La Vie parisienne*.

In England Max Beerbohm and George du Maurier provided the journal *Punch*, or the *The London Charivari* (from 1841) with a constant stream of caricatures that contributed to the tenacious idea that fashions for both men and women represented an absurdity. Its illustrator John Leech termed the word “cartoon” within *Punch* in 1843. The German middle-class public had numerous journals in which fashion caricatures recurred—*Punsch* (1847), *Leipziger Charivari* (1858), *Berliner Charivari* (1847), and *Kladderadatsch* (1848); the generic term “Biedermeier” for the period referred to a middle-class everyman fictional figure. The journal *Simplizissimus* (from 1896) led to the milieu in which expressionists like Georg Grosz (1893–1959) produced stinging comments on the human condition, using dress to mark out issues of class, gender, and sexuality. In North America enormous amounts of fashion-related caricature were produced for journals after the 1820s such as *American Comic Almanach* (from

1841), *Punchinello*, *Harper's Weekly*, and *Vanity Fair*. At the turn of the century the work of Charles Dana Gibson blurred the distinction between satire and the exaggerated fashionability of the Gibson girl, a gentle caricature that might be emulated for the turn of a head or silhouette of a skirt. In that the cartoon strip, comic book, and Disney film rely on caricature for their conventions, North America generated several industries from this form.

Until the post-World War II period when photography eclipsed line and other drawing in the media, the fashion caricature continued to be prominent within twentieth-century periodicals for all classes. Many of the fashion images commissioned by French couturiers including Paul Poiret approach the mannerism of caricature. The work of Erté (Romain de Tirtoff) also blurs the division between the fashion plate and the caricature in order to express a mood. Caricature images constitute important documents of relatively submerged topics including lesbianism and mannish dressing for women in the 1920s and male dress within homosexual communities. The commodification of dress and the rise of the fashion parade as a theatrical spectacle are documented in caricatures by figures such as Sem (Georges Goursat). The ironies of modernist lifestyle were documented by the British caricaturist Osbert Lancaster (*Homes Sweet Homes*, London, 1939). Wartime Britain and America used the caricature as propaganda to castigate wasteful female consumers. The emergence of the New Look was mocked as absurd or extravagant and unsuitable to matronly women in the late 1940s. Illustrator-designers, such as Cecil Beaton, provided high-style magazines like *Vanity Fair* and *Vogue* with both drawn and composite photographic or collaged backdrop renditions of real society women (Elsa Maxwell, the Duchess of Windsor, Coco Chanel) which teetered upon caricature, as well as producing cutting versions for private consumption (Violet Trefusis).

Although caricatures continue to be included as cartoons in newspaper and periodicals, their power declined with the advent of television as an alternative form of entertainment in the 1950s. It could be argued, however, that the techniques of the caricature, related as they were to the theater and vaudeville stereotype, continued within popular culture forms of television and film. Many 1950s and 1960s situation comedies such as *Green Acres* and *I Love Lucy* feature absurd situations involving dress; the 1990s comedy series *Absolutely Fabulous*, written and acted by Dawn French and Jennifer Saunders, made the fashion industry and absurd fashions in dress and lifestyle its subject, as did the Robert Altman film *Pret-à-Porter*. Other popular situation comedies, such as *Designing Women* from the 1980s, *Seinfeld*, and the overdressed and shopping-addicted figure of Karen in the queer sitcom *Will and Grace*, deploy caricature-like exaggeration of dress, pose, and identity which is intertwined with both ancient tropes of theatrical farce and the caricature print of modern culture.

Much postmodern high-fashion illustration in the 1980s and 1990s used the form of the caricature to comment ironically on the place of fashion in contemporary life. The designers Moschino, Christian Lacroix (spring–summer 1994), and Karl Lagerfeld utilize a caricature-like irony in some of their illustration derived from Directoire imagery by the likes of Louis LeCoeur and Debucourt, as well as studying the genre for ideas; some fashion parades and styling by John Galliano and Vivienne Westwood resemble a caricature suite brought to life as a conscious strategy. Galliano's degree show (1984) and some subsequent collections (spring–summer 1986) were directly inspired by *Incroyables et merveilleuses*. Forms that are directly derived from the eighteenth-century caricature continue to be published in daily newspapers (the political cartoon in which prominent figures are characterized through their dress), journals such as *Country Life* (Annie Tempest's Tottering-by-Gently series) and *The New Yorker* (established 1925). Although amusing and trenchant, such caricatures now have an archaic air and may be replaced in the future by the three-dimensional and new temporal possibilities of digital technology. In that surrealism found fertile pickings in English Georgian and nineteenth-century French and German caricature, it could be said that surrealist-inspired contemporary digital fashion photography by Phil Poynter and Andrea Giacobbe continues the ludic project of the fashion caricature consumed in multidimensional ways.

See also **Fashion, Historical Studies of.**

#### BIBLIOGRAPHY

- D'Oench, Ellen G. "Copper into Gold." *Prints by John Raphael Smith 1751–1812*. New Haven, Conn., and London: Yale University Press, 1999.
- Donald, Diana. *The Age of Caricature: Satirical Prints in the Reign of George III*. New Haven, Conn., and London: Yale University Press, 1996.
- . *Followers of Fashion. Graphic Satires from the Georgian Period*. London: Hayward Gallery Publishing, 2002.
- Duffy, Michael. *The Englishman and the Foreigner: The English Satirical Print 1600–1832*. Cambridge, Mass.: Chadwyck-Healey, 1986.
- George, Mary Dorothy. *Hogarth to Cruikshank: Social Change in Graphical Satire*. London: Allen Lane; Penguin, 1967.
- Hallett, Mark. *The Spectacle of Difference: Graphic Satire in the Age of Hogarth*. New Haven, Conn., and London: Yale University Press, 1999.
- Maidment, B. E. *Reading Popular Prints, 1790–1870*. Manchester, U.K., and New York: Manchester University Press, 1996.
- Paston, George [pseudonym for Miss E. M. Symonds]. *Social Caricature in the Eighteenth Century*. London: Methuen and Company, 1905.
- Paulson, Ronald. *Hogarth: His Life, Art, and Times*. 2 vols. New Haven, Conn., and London: Yale University Press, 1971.
- Perrot, Philippe. *Fashioning the Bourgeoisie: A History of Clothing in the Nineteenth Century*. Translated by Richard Bienvenu. Princeton, N.J.: Princeton University Press, 1994.



Sanders, Mark, et al. *The Impossible Image: Fashion Photography in the Digital Age*. London: Phaidon Press Ltd., 2000.

Peter McNeil

**CARNIVAL DRESS** In its broadest sense, “carnival” refers to a pageant, festival, or public celebration found all over the world. It originates in prehistoric times, varying in content, form, function, and significance from one culture to another. But in Europe and the Americas, “carnival” refers specifically to the period of feasting and revelry preceding Lent. The general consensus is that it began during the Middle Ages, evolving from the burlesque celebrations associated with Easter, Christmas, and other European festivities such as *Maypole*, *Quadrille Ball*, *Entrudo*, and *Hallowmas*. The word is said to derive from the Latin *carnem levare*, meaning abstention from meat or farewell to flesh, reflecting the self-denial such as fasting and penitence associated with Lent. Its synonyms are the French *carementrant* (approaching Lent), the German *fastnacht* (night of fasting) and the English

Shrovetide (referring to the three days set aside for confession before Lent).

Another school of thought links the word “carnival” to the Latin *carrus navalis*, a horse-drawn wagon for transporting revelers, arguing that its Christian aspects grew out of the seasonal Dionysian or Bacchanalian fertility rites of Greco-Roman times. These rites are noted for their emphasis on revelry, masquerading, satirical displays, and periods of symbolic inversion of the social order that provided an outlet for celebrants to let off steam.

In any event, while most of the principles underlying carnival remain more or less intact, its form, content, context, and dress modes have changed drastically over the centuries. This is particularly the case in the Americas where carnival was introduced after the fifteenth century following European colonization. Since then, it has absorbed new elements from the aboriginal populations, Africans and other ethnic groups. The emphasis here is on the carnival dress of the black diaspora in the Caribbean, United States, and Brazil where carnival is known by other names such as *Rara* in Haiti, *Mardi Gras* in New Orleans, and *Carnaval* in Cuba and Brazil.

The African contribution to carnival in the Americas began when the European slave masters allowed their African captives to display their ancestral heritage in the visual and performing arts on special occasions for recreational and therapeutic purposes. These occasions include the Day of the Kings in Cuba, the *Jonkonnu*, 'Lecture Day and Pinkster celebrations in the United States and the Caribbean as well as the *Batuque* (recreational drumming) in Brazil. The various attempts by enslaved blacks to revive African festival costumes in the Americas are well documented. Early eyewitness accounts describe slaves as donning horned masks and feathered headdresses, wearing shredded strips of cloth or painting their faces and bodies in assorted colors, just as they had done in their homeland. Some of these elements survive in the modern carnival, though in new forms and materials. Several sketches of carnival masquerades in nineteenth-century Jamaica by Isaac Belisario document African carryovers. One of them done during the Christmas celebrations in Kingston in 1836, depicts a mask with a palm leaf costume similar to that of the *Sangbeto* mask of the Yoruba and Fon of Nigeria and Republic of Benin respectively. A painting of the Day of the Kings celebration in Cuba executed in the 1870s by the Spanish-born artist Victor Patricio de Landaluze shows not only black figures playing African drums, but also dancers wearing raffia skirts and animal skins. Near the drummers is a masquerade with a conical headdress introduced to Cuba by Ekoi, Abakpa, and Ejagham slaves from the Nigerian–Cameroon border where the masquerade is associated with the *Ekpe* leadership society. Now called *Abakua*, this masquerade is still a feature of the twenty-first-century carnival in Cuba. Another African retention in the modern carnival among blacks in the Americas and Europe is the *Moco Jumbie*, a masquerade on stilts. Apart from the fact that this masquerade type



**Women at carnival in Spain.** Girls dress in traditional costumes during the carnival celebrations in Seville, Spain. © PATRICK WARD/CORBIS. REPRODUCED BY PERMISSION.

abounds all over Africa, it appears in the prehistoric rock art of the Sahara desert as early as the Round Head period, created about eight thousand years ago.

At first, the public celebrations by free and enslaved blacks in the Americas during the slavery era occurred on the fringes of the white space. However, by the beginning of the twentieth century, emancipation had brought about various degrees of racial integration, allowing blacks, whites, Creoles, Amerindians, and new immigrants from Europe, Middle East, Asia, and the South Pacific to perform the carnival together. Each group has since contributed significantly to the repertoire of carnival dress, while at the same time borrowing elements from one another. For instance, even though the emphasis on feathers in some masquerades has African precedents, influences from Amerindian costumes are apparent as well, most especially in the black Indian Mardi Gras costumes of New Orleans.

In the early 2000s a typical carnival is a public procession of musicians, lavishly attired dancers and colorful masquerades. Some are transported on decorated floats. The areas to be covered by the parade are usually closed to traffic. The costumes often combine assorted materials—fabrics, plastic beads, feathers, sequins, colorful ribbons, glass mirrors, horns, and shells—all aimed at creating a dazzling spectacle. In some areas, the parade lasts one, two, or three days; and in others, a whole week. There is usually a grand finale at a public square or sports stadium where all participants perform in turn before thousands of spectators. In Trinidad, Brazil, and other countries, a panel of judges selects and awards prizes to the most innovative groups and to the masquerades with the best costumes. As a result, carnival has turned into a tourist attraction—a big business, requiring elaborate preparations. In most cases, participants are expected to belong to established groups or specific clubs such as the Zulu of New Orleans, Hugga Bunch of St. Thomas (U.S. Virgin Islands), Ile Aye of Salvador (Brazil) and African Heritage of Notting Hill Gate (United Kingdom) whose members are expected to appear in identical costumes. Each group usually has a professional designer who is responsible not only for its costume themes, styles, colors, and forms, but also the group's dance movements. In Brazil, where African-derived festivals have been assimilated into the carnival, religious groups (*Candomble*) associated with the worship of Yoruba deities (*orixá*) may emphasize the sacred color of a particular deity in their carnival costumes. Thus, white honors *Obatala* (creation deity), blue, *Yemaja* (the Great Mother), red, *Xango* (thunder deity), and yellow, *Oxun* (fertility and beauty deity). Designers such as Fernando Pinto and Joaosinho Trinta of Brazil and Hilton Cox, Peter Minshall, Lionell Jagessar and Ken Morris—all of Trinidad—have become world-famous for their innovations. Some of Peter Minshall's costumes, for example, are monumental, modernistic puppetlike constructions whose articulated parts respond rhythmically to dance movements. Other cos-

tumes by him incorporate elements of traditional African art in an attempt to relate the black diaspora to its roots in Africa. This nationalism has led a number of black designers to seek inspiration from African costumes and headdresses, recalling the original contributions of African captives to carnival during the ancient *Jonkonnu*, Pinkster and Day of the Kings celebrations when they improvised with new materials.

In the recent past, grasses, leaves, raffia, flowers, beads, furs, animal skins, feathers, and cotton materials were used for the costumes. These materials are increasingly being replaced by synthetic substitutes, partly to reduce cost and partly to facilitate mass production. Some costumes or masquerades depict animals, birds, insects, sea creatures, or characters from myths and folklore. Others represent kings, Indians, celebrities, African or European culture heroes, historical figures, clowns, and other characters. Cross-dressing and masquerades with grotesque features are rampant. So too is seductive dancing. The loud music—calypso in the Caribbean and samba in Brazil—adds to the frenzy, allowing performers and spectators alike to release pent up emotion.

See also **America, South: History of Dress; Cross-Dressing; Masquerade and Masked Balls.**

#### BIBLIOGRAPHY

- Besson, Gerard A., ed. *The Trinidad Festival*. Port of Spain, Trinidad and Tobago: Paria, 1988.
- Cowley, John. *Carnival, Canboulay and Calypso: Traditions in the Making*. Cambridge, U.K.: Cambridge University Press, 1996.
- Golby, J. M., and A. W. Purdue. *The Making of the Modern Christmas*. Athens: University of Georgia Press, 1986.
- Harris, Max. *Carnival and Other Christian Festivals: Folk Theology and Folk Performance*. Austin: University of Texas Press, 2003.
- Hill, Errol. *Trinidad Festival: Mandate for a National Theatre*. Austin: University of Texas Press, 1972.
- Huet, Michel, and Claude Savary. *The Dances of Africa*. New York: Harry N. Abrams, 1996.
- Humphrey, Chris. *The Politics of Carnival*. Manchester, U.K.: Manchester University Press, 2001.
- Lawal, Babatunde. *The Gèlèdè Spectacle: Art, Gender, and Social Harmony in an African Culture*. Seattle: Washington University Press, 1996.
- Mason, Peter. *Bacchanal! The Carnival Culture of Trinidad*. Philadelphia: Temple University Press, 1998.
- Minshall, Peter. *Callaloo an de Crab: A Story*. Trinidad and Tobago: Peter Minshall, 1984.
- Nettleford, Rex M. *Dance Jamaica: Cultural Definition and Artistic Discovery*. New York: Grove Press, 1986.
- Nicholls, Robert W. *Old-Time Masquerading in the U.S. Virgin Islands*. St. Thomas, U.S. Virgin Islands: Virgin Islands Humanities Council, 1998.
- Nunely, John W., and Judith Bettelheim. *Caribbean Festival Arts: Each and Every Bit of Difference*. Seattle: University of Washington Press, 1988.

- Orloff, Alexander. *Carnival: Myth and Cult*. Wörgl, Austria: Perlinger, 1981.
- Poppi, Cesare. "Carnival." In *The Dictionary of Art*. Edited by Jane Turner. Vol. 5. London: Macmillan Publishers, 1996.
- Teissl, Helmut. *Carnival in Rio*. New York: Abbeville Press Publishers, 2000.
- Turner, Victor, ed. *Celebration: Studies in Festivity and Ritual*. Washington, D.C.: Smithsonian Institution Press, 1982.

*Babatunde Larwal*

**CASHIN, BONNIE** One of America's foremost designers in the second half of the twentieth century, Bonnie Cashin (1908–2000) was a pioneer in the sportswear industry, specializing in modular wardrobes for the modern woman "on the go." Her lifelong interest in clothing design, however, encompassed a number of careers on both American coasts. Growing up in California, Cashin worked as an apprentice in a series of dressmaking shops owned and operated by her mother, Eunice. In her teens she worked as a fashion illustrator and dance costume designer. Between 1943 and 1949 she costumed more than sixty films at Twentieth Century–Fox. It was not until midcentury, when she was over forty years old, that she began designing the ready-to-wear for which she became best known.

Cashin favored timeless shapes from the history of clothing, such as ponchos, tunics, Noh coats, and kimonos, which allowed for ease of movement and manufacture. Approaching dress as a form of collage or kinetic art, she favored luxurious, organic materials that she could "sculpt" into shape, such as leather, suede, mohair, wool jersey, and cashmere, as well as nonfashion materials, including upholstery fabrics. Cashin's aim was to create "simple art forms for living in, to be re-arranged as mood and activity dictates" (Interview 1999).

### Early Years

As a girl moving along the California coastline, Cashin developed a love for travel and a keen eye for the clothing of different cultures, which would underpin her later professional work. This interest in "why people looked the way they did" placed her in good stead to begin work in 1924, alongside Helen Rose, as a costume designer for the Los Angeles dance troupe Fanchon and Marco. In 1934 her producers took over performances at New York's Roxy Theater and asked Cashin to join them as costumer for the Roxyette dance line, the precursors and rivals to the Rockettes.

### Fashion and Film

In 1937 the *Harper's Bazaar* editor Carmel Snow, an admirer of Cashin's costume designs, encouraged Bonnie to work in fashion and arranged for her to become the head designer for the prestigious coat and suit manufacturer Adler and Adler. Owing to the wartime focus on Ameri-

can fashion design, she became so well recognized that she was commissioned to design World War II civilian defense uniforms and was featured in a Coca-Cola advertisement. By 1942, however, Cashin felt boxed in by wartime restrictions. She returned to California to sign a six-year contract as a costume designer with Twentieth Century–Fox.

Cashin designed costumes for the female characters in more than sixty films. Her favorite projects, *Laura* (1944), *A Tree Grows in Brooklyn* (1945), and *Anna and the King of Siam* (1946), also became American cinematic classics. Designing for the lavish productions that typified Hollywood's golden age, she was expected to make innovative use of the day's finest materials to create historical, fantasy, and contemporary wardrobes. She used the resources at the Fox studios to experiment with designs for "real" clothing that she wore and made in custom versions for her leading ladies' offscreen wardrobes.

### Return to Ready-to-Wear

Cashin returned to New York, and to Adler and Adler, in 1949. She received the unprecedented honor of earning both the Neiman Marcus Award and the Coty Fashion Critic's Award within the same year (1950). Displeased, however, with her manufacturer's control over her creativity, she decided to challenge the setup of the fashion industry. Working with multiple manufacturers, she designed a range of clothing at different price points, thereby specializing in complete wardrobes for "my kind of a girl for a certain kind of living."

In 1953 Cashin teamed with the leather importer and craftsman Philip Sills and initiated the use of leather for high fashion. She made her name through her unconventional choices in materials as well as her inexhaustible variations on her favorite theme of adapting the flat, graphic patterns of Asian and South American clothing to contemporary global living. Through her work for Sills and Company, she is credited with introducing "layering" into the fashion lexicon. In turn, she credited the Chinese tradition of dressing for, and interpreting the weather as, a "one-shirt day" or a "seven-shirt day." Her layered garments snugly nestled within one another and were easily converted to suit different temperatures and activities by donning or removing a layer. Cashin's objective was to create a flexible wardrobe for her own globe-trotting lifestyle, wherein seasonal changes were only a plane trip away. Frustrated by the categorization of sportswear designer, she declared that travel was her "favorite sport."

### Coach and the Cashin Look

In 1962 Cashin became the first designer of Coach handbags and initiated the use of hardware on clothing and accessories, including the brass toggle that became Coach's hallmark. She revolutionized the handbag industry. Unlike contemporary rigid, hand-held bags, her vividly colored "Cashin-Carries" for Coach packed flat and had wide straps, attached coin purses, industrial zippers, and the famous sturdy brass toggles, the last inspired



by the hardware used to secure the top on her convertible sports car.

Without licensing her name, Cashin designed cashmere separates, gloves, canvas totes, at-home gowns and robes, raincoats, umbrellas, and furs. She also ran the Knittery, a consortium of British mills that produced one-of-a-kind sweaters knit to shape, rather than cut and sewn. Among many other industry awards, she received the Coty award five times and entered their hall of fame in 1972; in 2001 was honored with a plaque on the Fashion Walk of Fame on Seventh Avenue in New York City.

Cashin worked until 1985, when she decided to focus on painting and philanthropy. Among several scholarships and educational programs, she established the James Michelin Lecture Series at the California Institute of Technology. Cashin died in New York on 3 February 2000 from complications during heart surgery. In 2003 the Bonnie Cashin Collection, consisting of her entire design archive and endowments for design-related lecture series and symposia, was donated to the Department of Special Collections within the Charles E. Young Research Library at the University of California, Los Angeles.

See also **Costume Designer; Dance Costume; Film and Fashion; Ready-to-Wear; Sportswear.**

#### BIBLIOGRAPHY

Cashin, Bonnie. Interview by Stephanie Day Iverson. 12 September 1999.

Iverson, Stephanie Day. "Early' Bonnie Cashin, before Bonnie Cashin Designs, Inc." *Studies in the Decorative Arts* 8, no. 1 (2001–2002): 108–124.

Steele, Valerie. *Women of Fashion: Twentieth-Century Designers*. New York: Rizzoli International, 1991.

*Stephanie Day Iverson*

**CASHMERE AND PASHMINA** On the windswept plateaus of Inner Asia, in a huge swathe encompassing Afghanistan, India's Ladakh, parts of Sinkiang, northern Tibet, and Mongolia, nomadic herdspeople raise great flocks of sheep, goats, and yak. The altitude, over 14,000 feet (4,300 meters), precludes cultivation; herding is the only possible economic use of a bleakly inhospitable environment. The bitter cold of winter, plummeting to minus 40 degrees Fahrenheit and below and aggravated by windchill, provokes the growth of a warm, soft undercoat of downy fibers in many of the region's mammals—goats, camels, yak, even dogs, as well as wild animals like the ibex and the Tibetan antelope or chiru. Known in the



**Luxurious pashmina shawls are woven in Kashmir, India.** Pashmina, a fabric woven from the downy fibers from goats, was an important part of the Indo-Iranian royal lifestyle in eighteenth and nineteenth centuries and was traded as far as Russia, Armenia, and Egypt. © EARL & NAZIMA KOWALL/CORBIS. REPRODUCED BY PERMISSION.



**Cashmere yarn.** Cashmere was produced painstakingly by hand until the twentieth century, when expanding demand for the fabric led to increased production. Now rolls of cashmere yarn are produced mechanically and are stored in clothing factories, like this one in the United Kingdom, ready for mass production. © HULTON-DEUTSCH COLLECTION/CORBIS. REPRODUCED BY PERMISSION.

Northern languages of urdu and Kashmiri as *pashm*, this fiber is collected in commercial quantities from the herdspeople's goats. (Some authorities have identified the breed of *pashm*-producing goats as *Capra hircus*. This name, however, applies to all domesticated goats; scientific taxonomy makes no distinction between different breeds of domesticated animals.) The double-humped Bactrian camel also produces a less fine grade ("camel hair"). When the term *pashm* is used without qualification, it is goats' *pashm* that is meant.

*Pashm* was and is the raw material for the shawl industry of Kashmir. The fabric woven from *pashm* is properly called *pashmina*. When the British in India became aware of the Kashmir shawl, however, some of them, ignorant of the fiber's origin, adopted the term "cashmere" to refer to both fiber and fabric, and in the West this is the term that has stuck.

### The Kashmir Shawl

The transformation of a mass of greasy, matted fibers into a patterned fabric of superlative softness and warmth involved a whole complex set of procedures. To begin with, the raw material had to be cleaned and the coarse hairs from the animal's outer coat removed. These processes and the spinning of the thread were (and continue to be) done by Kashmiri women in their homes, with the simplest of tools like combs, reels, and hand-operated spinning-wheels.

The classic means of decorating shawl-goods was by the twill-tapestry technique, unique to the manufacture of this fabric: a twill weave using, instead of a shuttle, a multiplicity of small bobbins laden with different colors of yarn to incorporate the design into the weave. Designers drew and colored the pattern, and a scribe translated it into a shorthand form called *talim*. Dyers tinted

the yarn in the required colors with vegetable dyes, and other specialists made and dressed the warp and put it to the loom. Only then did the weaver put his hand to it. Two weavers sat at each loom, manipulating the bobbins in response to the instructions of the master weaver reading aloud from the *talim*. Shawls were woven in pairs, and an elaborate design could be months or even years in the making.

In the nineteenth century, as patterns became more complex, shawls were often woven in numerous small pieces, the skill of the danner who joined them together being such that the seams were practically invisible and the whole looked and felt like a single piece of material. Another development of the nineteenth century was the substitution of embroidery on plain pashmina fabric for tapestry work. At the start of the twenty-first century the skills of the twill-tapestry weaver have all but disappeared, but perhaps more embroidered pashmina shawls are being produced in Kashmir than ever before, in response to demand from the prosperous Indian middle class. Simultaneously, efforts are under way to revive the art of twill-tapestry, as well as to diversify the product, and a small number of superlative pieces are being created in both traditional and innovative techniques and designs.

From the mid-eighteenth century till about 1870, the shawl industry was heavily taxed and provided more revenue for successive governments of Kashmir than all other sources together. This burden of taxation fell most heavily on the weavers, the exploitation of whom reached an extent that could be described almost as serfdom.

The pashmina shawl of Kashmir has always been a luxury item; more than that, its beauty and fineness made

it an integral part of the royal and aristocratic lifestyle of the Indo-Iranian world in the eighteenth and first half of the nineteenth centuries. It was exported as far afield as Russia, Armenia, Iran, Turkey, Egypt, and Yemen, long before it took the West by storm. The term “shawl” (originally *shal*) was not at that time confined to shoulder mantles, and the fabric often took the form of *jamawar*, or gown-pieces, designed to be made up into tailored clothes. There was indeed an extraordinary variety of “shawl-goods,” including turbans, waist-girdles, saddle-cloths for horses and elephants, curtains, carpets, and tomb-coverings. It was only in India that the long shawl was worn—by men, not women—as a shoulder-mantle. Elsewhere in Asia, men wore turbans or sashes of shawl fabric; or coats (*jama, qaba, choga*) tailored from *jamawar*. Shawls for women were square, and designed to be worn folded into a triangle around the shoulders or waist. It was only when they became a part of high fashion in Europe, especially France, and the United States of America, between approximately 1790 and 1870, that long shawls, as well as square ones, were appropriated to women’s wear.

### Cashmere Beyond Kashmir

Until about 150 years ago, the skills necessary to process *pashm* into a fabric that would realize its potential of delicacy as well as warmth existed only in Kashmir. The nineteenth century saw the beginning of a demand for *pashm*—under the appellation “cashmere”—from the West. Around 1850, European demand for luxury woolen-type fibers seems to have been met first of all by vicuña from South America; but as this grew scarce and



### THE ORIGIN OF *TOOSH*

It is the chiru (*Pantholops hodgsoni*) that is the source of *toosh* (occasionally known as *tus*, also *shahtoosh*), a variety of *pashm* even more delicate than that from the goat, from which the famous “ring-shawls” were made. It is perhaps the finest animal material that has ever been put to the loom, the mean diameter of the fibers being in the region of 9 to 12 microns—about three-quarters that of cashmere. Sadly, no method has been found of harvesting the fiber from the living animal. Until about the middle of the twentieth century, the slaughter of chiru for *pashm* was on a sustainable basis, and herds numbering tens of thousands were reported by travelers in Tibet. The opening up of Tibet after about 1960 and the emergence of the shahtoosh shawl as a high-fashion

luxury item in the West, changed all that; and in the last 40 years there has been wholesale slaughter, an estimated 20,000 chiru being shot or trapped every year, while in 2000 the surviving population was estimated at a mere 75,000, down from perhaps a million in mid-century. In the twenty-first century, the chiru is recognized as being in imminent danger of extinction, and is classified under Appendix I of the Convention on International Trade in Endangered Species (CITES). Although trade in the animal and its products is accordingly banned everywhere in the world, it is believed that the slaughter continues, and that *toosh* is still being processed in Kashmir into shawls that are sold illegally in India and the West.



expensive, cashmere was increasingly used as a substitute, finally superseding vicuña completely. From as early as the 1860s commercial supplies were sourced from Mongolia rather than Tibet. Earlier it was only in the tracts convenient to Kashmir—that is southeastern Ladakh and western Tibet—that large-scale production actually took place, the amount reaching Kashmir annually in the 1820s being estimated at between 120,000 and 240,000 pounds. Expanding demand from the West through the twentieth century led to increased production, as nomadic herdspeople all over the potential *pashm*-producing area increased the proportion of goats in relation to sheep among their flocks. In the twenty-first century, total world production is in the region of 14,000 tons, the bulk of it from China (Tibet) and Mongolia.

Western companies have developed mechanical means of processing the fiber, even the finicky process of de-hairing (though in the twenty-first century almost all the Chinese and Mongolian *pashm* is exported already de-haired). They process it into both woven fabrics and yarn suitable for knitwear. The so-called “pashminas” that became so fashionable in the West in the 1990s were originally woven in Nepal from a mixture of *pashm* and silk. They are now also being produced in many different qualities in various centers in India and the term is frequently misapplied by retailers in the West to similar-looking fringed shawls woven from fine sheep’s wools.

See also **Fur; India: Clothing and Adornment; Shawls.**

#### BIBLIOGRAPHY

- Ahmed, Monisha. *Living Fabric, Weaving Among the Nomads of Ladakh Himalaya*. Bangkok: Orchid Press, 2002.
- Ames, Frank. *The Kashmir Shawl and Its French Influence*. Woodbridge, U.K.: The Antiques Collectors, 1986.
- Beardsley, Grace. “Piecing in Twill Tapestry Shawls of Persia and Kashmir.” In *Textiles as Primary Sources: Proceedings of the First Symposium of the Textile Society of America*. St. Paul, Minn.: The Textile Society of America, 1988.
- Goldstein, Melvyn C., and Cynthia M. Beall. *Nomads of Western Tibet: The Survival of a Way of Life*. Hong Kong: Odyssey Productions, 1990.
- Harrison, E. P. *Scottish Estate Tweeds*. Elgin, Scotland: Johnstons of Elgin, 1995.
- IFAW and Wildlife Trust of India. *Wrap Up the Trade: An International Campaign to Save the Tibetan Antelope*. New Delhi, 2001.
- Internet Resource*
- Chiru Factsheet. Available from  
<http://www.earthisland.org/tpp/chirufacts.htm>.

Janet Rizvi

**CASUAL BUSINESS DRESS** During the 1990s in the United States a trend in dressing casually for work became more widespread in business offices. The trend soon spread to other countries such as Canada, England,

Scotland, and Australia. Casual dress in the office may reflect a larger societal trend toward relaxation of manners and informal presentation of self in many aspects of life (Adler 1995) and may be symptomatic of a shift away from traditional ways of doing business (Janus, Kaiser, and Gray 1999; Weiser 1996).

#### Casual Business Dress Defined

Casual work dress has been identified by a number of terms, such as “dressing down,” “business casual,” and “Casual Day” dress. In a national U.S. study, Tootelian (2003) found that substantial uncertainty exists about what business casual means. The definition presented here is gleaned from a number of sources and can be offered only as a general and imprecise guideline.

Delineation of what is formal business dress is necessary to define categories of casual business dress. The sidebar contains a description of the standard for formal business dress at the turn of the twenty-first century. Women’s formal business dress remains more varied than men’s (Ogle and Damhorst 1999).

For men and women, “business casual” dress tends to include a reinterpretation of at least one formal power cue into a more casual ensemble (Rucker, Anderson, and Kangas 1999). A jacket (often a blazer or sports jacket) may be worn with more casual khaki pants and shirt, or a tie is worn without a jacket. Sweaters are permissible with a skirt or pants. Shoes are often more casual and comfortable. A great amount of variety is present, but includes more limits than does “casual dress.”

Some offices allow highly casual dress, including jeans and shorts. Permissible styles vary greatly across firms, geographic areas, and occupations (Ogle and Damhorst 1999) and age and gender of workers (Tootelian 2003).

#### History of the Trend

The increase of casual dress among office workers began far earlier than the 1990s. Farrell-Beck (1999) offered evidence that components of men’s casual dress have frequently been adapted into men’s formal business wear throughout its history. King Charles II of England originally instituted the men’s business suit in 1666 as an alternative to fancier styles popular in men’s court dress throughout Europe (Kuchta 1990). The ensembles adopted by men of court and commerce to some extent reflected informal fashions worn by English country gentlemen (Kuchta 1990). The casual trend at the end of the twentieth century, however, did not entail a metamorphosis of casual into formal symbols. Casual Day and casual every day in essence have become a celebration of the right of office workers to legitimately wear casual clothing to work in the office.

The casual dress trend for business professionals may have begun during the 1970s as the computer industry blossomed. Silicon Valley computer “geeks” are often

cited as the first to be given license to dress very casually at work (Weiser 1996). In certain areas of the country, some forms of casual dress were an option in many types of businesses by the late 1970s. In 1975 John Molloy railed against offices that were allowing men to wear the infamous leisure suit in place of a formal suit. A few managers in an early 1980s study of office workers in Austin, Texas, reported that they frequently went to work in somewhat casual attire, making them keep a jacket and tie at the office just in case a client might drop by (Damhorst 1984–1985). Saturn Corporation has encouraged casual work dress for employees at all levels in the organization since its inception in 1983 (Levi Strauss & Co. 1999).

A series of Levi Strauss & Co. surveys were quoted in the popular press during the 1990s to chronicle the rise of casual business dress. By 1992, 26 percent of businesses in the United States reported offering at least a casual attire day (Weiser 1996). Companies allowing casual dress every day rose to 33 percent in 1995 and 53 percent in 1997 (Maycumber 1998).

Reporters cite a new rash of surveys in the early twenty-first century to forewarn of the possible demise, or at least notable reduction, of the casual office dress trend. For example, the Men's Apparel Alliance found that 19 percent of over 200 firms with revenues greater than \$500 million were returning to formal business attire (Egodigwe and Alleyne 2003). In 2000, only 87 percent of U.S. firms allowed casual dress, down 10 percent from 1998 (Kaplan-Leiserson 2000). The tough economy in the early 2000s was moving some companies to abandon a casual image to combat intense competition.

### Functions of Casual Dress

Casual work dress has been imputed to have an array of symbolic powers (Biecher, Keaton, and Pollman 1999; Henricks 1996; Janus, Kaiser, and Gray 1999). Casual dress is believed to facilitate democratization through horizontal flattening of workplace hierarchies and to break down communication barriers posed by formal structures, thereby improving teamwork. Casual work dress may improve customer relations by implying mutual similarity. Many managers feel that casual dress improves employee morale and enhances worker productivity. Correspondingly, many firms instituted casual dress policies during the 1990s to reward workers and attract new recruits. In addition, communication technology used in many occupations increasingly allows people to do much business without ever coming face-to-face with clients or vendors, eliminating a need for constant expression of corporate image through dress.

Critics cite some negative outcomes of casual work dress, such as negative organizational image and confusion about how to define and enforce workplace dress policies (Egodigwe and Alleyne 2003). Confusion among employees about what to wear to work is not uncommon (Janus Kaiser, and Gray 1999; Tootelian 2003). Some critics assume that lack of control underlies the relaxation



### CLASSIC FORMAL DRESS STANDARDS

#### *For Men*

- A two-piece suit;
- A jacket and pant with matching fabrics;
- Smooth wool or blend fabrics in solid colors or pinstripes;
- A jacket that has classic tailoring, a convertible collar, and welt pockets;
- A tie;
- A shirt;
- White or light colored stand-up collar; and
- Leather shoes in brown or black

#### *For Women*

- Pants, skirted suits, and dresses;
- A jacket worn closed with no blouse underneath;
- A jacket worn with a variety of blouses and knit tops;
- Jackets may be collarless, have varied pocket styles, and vary in length from upper to lower hip area;
- Neckline exposure is modest (no cleavage);
- Skirt length varies but not too far above the knee;
- Fabrics similar to men's suiting but in a greater variety of colors;
- Subdued tweeds or plaids;
- Jewelry is limited, one or two small pieces are permissible;
- Sheer hosiery, nude or in colors that blend with the skirt; and
- Shoes with closed-toe and one-inch or higher heels

to casual codes (Lillethun 1999), and many businesses in the early 2000s were concerned that casual work dress had resulted in increased tardiness, absenteeism, flirtatious behavior on the job, and an overall decrease in productivity (Egodigwe and Alleyne 2003). Powerful consequences of casual business dress have been attributed over time, but no research has been reported to verify any valid correlation of positive or negative outcomes for workplace behavior.

*See also* **Uniforms, Occupational.**

#### BIBLIOGRAPHY

- Adler, Jerry. "Have We Become a Nation of Slobs?" *Newsweek* 25 (20 February 1995): 56–62.
- Biecher, Elisa, Paul N. Keaton, and A. William Pollman. "Casual Dress at Work." *SAM Advanced Management Journal* 64 (Winter 1999): 17–20.

- Damhorst, Mary Lynn. "Meanings of Clothing Cues in Social Context." *Clothing and Textiles Research Journal* 3, no. 2 (1984–1985): 39–48.
- Damhorst, Mary Lynn, Kelly Jondle, and Christi Youngberg. "How Personnel Interviewers See Women's Job Interview Dress—A 2002 Update." In *The Meanings of Dress* 2nd ed. Edited by Mary Lynn Damhorst, Kimberly A. Miller, and Susan O. Michelman. New York: Fairchild Publications, 2004.
- Egodigwe, Laura, and Sonia Alleyne. "Here Come the Suits." *Black Enterprise* 3, no. 8 (March 2003): 59.
- Farrell-Beck, Jane. "Not So New: Casual Dress in the Office." In *The Meanings of Dress*. Edited by Mary Lynn Damhorst, Kimberly A. Miller, and Susan O. Michelman, 258–261. New York: Fairchild Publications, 1999.
- Henricks, Mark. "Informal Wear: Does Dressing Down Send Productivity Up?" *Entrepreneur* 24, no. 1 (January 1996): 79–82.
- Janus, Teresa, Susan B. Kaiser, and Gordon Gray. "Negotiations @ Work: The Casual Businesswear Trend." In *The Meanings of Dress*. Edited by Mary Lynn Damhorst, Kimberly A. Miller, and Susan O. Michelman, 264–268. New York: Fairchild Publications, 1999.
- Kaplan-Leiserson, Eva. "Back-to-Business Attire." *Training and Development* 54 (November 2000): 39.
- Kuchta, David. "'Graceful, Virile, and Useful': The Origins of the Three-Piece Suit." *Dress* 17 (1990): 18–26.
- Levi Strauss & Co. "Saturn Corporation: A Casual Businesswear Case Study." In *The Meanings of Dress*. Edited by Mary Lynn Damhorst, Kimberly A. Miller, and Susan O. Michelman, 257–258. New York: Fairchild Publications, 1999.
- Lillethun, Abby. "An Interpretation of Negative Press Coverage of Casual Dress." In *The Meanings of Dress*. Edited by Mary Lynn Damhorst, Kimberly A. Miller, and Susan O. Michelman, 261–264. New York: Fairchild Publications, 1999.
- Maycumber, S. G. "Young Men's Pants Preference Shifting." *Daily News Record* 28, no. 4 (9 January 1998): 8–9.
- Molloy, John T. *Dress for Success*. New York: Warner Books, 1975.
- Ogle, Jennifer P., and Mary Lynn Damhorst. "Dress for Success in the Popular Press." In *Appearance and Power*. Edited by Kim K. P. Johnson and Sharron J. Lennon, 79–101. Oxford, and New York: Berg, 1999.
- Rucker, Margaret, Elizabeth Anderson, and April Kangas. "Clothing, Power, and the Workplace." In *Appearance and Power*. Edited by Kim K. P. Johnson and Sharron J. Lennon, 59–77. Oxford, and New York: Berg, 1999.
- Weiser, Jay. "Denim Downsize." *The New Republic* 214, no. 9 (26 February 1996): 10–11.

#### Internet Resource

- Tootelian, Dennis. "Mervyn's Career Casual Survey: Summary Report of Key Research Findings." Attachment to "CSUS Study Shows Workplace Fashion Confusion." Capital University News (10 February 2003). Available from <<http://www.csus.edu/news/021003fashion.htm>>.

Mary Lynn Damhorst

**CELEBRITIES** In November 2003, the Prince's Trust, an organization set up by Prince Charles to help disadvantaged young people, organized a charity event in the Albert Hall: "Fashion Rocks," a collaboration between the worlds of music and fashion. It was hosted by Elizabeth Hurley, the epitome of a new type of celebrity. She has been photographed constantly for nearly ten years, and used for countless magazine covers, including British *Vogue*. She has a multimillion-dollar contract with Estée Lauder, and her private life is constantly subject to close tabloid scrutiny. Everyone, it seems, knows who she is—she is often named in headlines as, simply, "Liz." If a job description is ever necessary, she is referred to as "model and actress." Yet apart from magazine covers where she is used because of her celebrity, and the Lauder campaign, she does no modeling. The films in which she has appeared—with the exception of *Austin Powers: The Spy Who Shagged Me* (1999) have done very badly at the box office. It would be more accurate to say that she is part of a new group of celebrities who have been instantly created by and perpetuated within the media. She is, quite simply, a construct—and, paradoxically, it is this that makes her a celebrity.

Her career in fact began in 1994, at the London premiere of *Four Weddings and a Funeral*. She accompanied her boyfriend, Hugh Grant, and borrowed a dress from the London offices of Versace. The black dress was short and revealing—held together by large, strategically placed safety pins. The following day she appeared on the front page of all tabloid and middle-market newspapers in Britain, while even the broadsheets saw fit to include the "story" on their inside pages. Since then, she has been continually photographed, and the dress has been retrospectively discussed as "That Dress." Indeed, when Grant was convicted of an indiscretion with a Hollywood prostitute, the English Sunday paper found the woman in question and photographed her wearing a red version of the Versace dress, which they put on their front page. Unsurprisingly, Versace has offered Hurley clothes for every subsequent photo opportunity, and she has repaid them by being photographed in all of them. One of the dresses was slit so high up the thigh that it revealed a pair of knickers in a leopard-print fabric to match the dress. Hurley is a perfect example of the new breed of fashion celebrity for, unlike fashion celebrities of the past, her taste is often deemed to be questionable. On this particular occasion, she was censured in the press for having worn this outfit, since it was to a "society wedding," and it was suggested that she had wished to divert attention away from the bride. This is in direct contrast to the former notion of a fashion celebrity who attained his or her status precisely because their taste in clothes was deemed to be excellent.

While there are still fashion celebrities who have been selected for their ability to look stylish—the model Kate Moss is a perfect example—the majority of today's celebrities are seen as legitimate targets for sartorial crit-



icism. A weekly staple of journalism is now a roundup of the past week's fashion triumphs and disasters; if a celebrity wears a particularly unbecoming or unsuitable outfit, an appearance in the papers the very next morning is guaranteed.

A "celebrity," however, as opposed to an "icon," has always had a notoriety over and above the sum of their talent. But one of the many problems with today's culture of celebrity is a seeming disregard for the absence of any particular talent apart from the simple fact of being photogenic. Another is the disproportionate amount of media attention given over to celebrity stories. The past decade has seen an unprecedented growth in the cult of the celebrity—it is very different from the carefully controlled interest in "stars" that characterized the heyday of Hollywood.

Interestingly, it has meant huge shifts within the fashion industry, which seem to have gone at times unremarked. For instance, it was traditional within magazine journalism—from its infancy at the end of the last century until the late 1990s—for leading fashion journalists to have some effect on the success or failure of a particular collection, a particular look, and for the journalists themselves, if prestigious enough, to be able to assist the career of new designers. Some journalists are still sufficiently well known to be photographed as celebrities in their own right, known for their own particular style. Just as from the 1930s to the 1950s the characteristic "look" of Diana Vreeland was frequently discussed, so today Anna Piaggi of Italian *Vogue* is still photographed, as is Suzy Menkes of the *International Herald Tribune*. However, these are among a few exceptions—arguably the photographs from the collections are now of the celebrities in the front row—and it is their choice of designer or outfit which makes for success. Julien Macdonald owes his career as a designer to the fact that he was asked, early on, to design for Kylie Minogue. Donatella Versace has ensured the continued good fortunes of the house for which she designs not only through her shrewd use of different celebrities—she organized a wedding party for Jennifer Lopez, and always dresses singers for music award ceremonies—but through the fact that she has become a fashion celebrity in her own right. Her characteristic heavy makeup, long bleached-blond hair, and year-round suntan are the constant focus of media comment.

Not only have journalists lost their power over designers, they have watched their employers make radical changes to cope with the new obsession with celebrity. The magazine *InStyle*, launched in America in 1998 by the publishers of *People*, has been extremely successful and has created a new template for fashion journalism both in America and the United Kingdom. Celebrities, rather than models, are now used for many cover shots, while the fashion and beauty pages tell their readers how to emulate particular star "looks."

Journalism has gone through extraordinary changes over the last century. A hundred years ago, "celebrity

photographs" were rare within magazine journalism, and tended to involve the aristocracy or royalty. There was still some use of sketches; the British magazine *Queen* was specifically set up to portray the weekly activities of Queen Victoria and her companions and to depict the lifestyle of the very uppermost echelons of British society, and these scenes could not be photographed. But the development of the cinema brought the royal family onto the screen in newsreels, and they became the subject of special short films on ceremonial occasions. Princess Alexandra—later Queen herself—was of great interest because of her elegance in dress—royalty and aristocracy continued to be of interest as the new media forms developed. In the period between the two World Wars, Pond's ran a famous advertising campaign which used "society ladies," invariably titled, to endorse their range of skin-care products. But tastes gradually changed—celebrity endorsement for cosmetics and beauty products was more likely, by 1939, to involve a Hollywood star.

As advertising has become more sophisticated, so it has cast its net more widely. Not only has it used celebrities from every sphere of activity—the first sportsman to appear in a fashion-related advertisement was Henry Cooper, the British boxing champion, who advertised the aftershave, Brut, in the 1970s—but it has also created its own minor, usually transient, celebrities through its campaigns. A perfect example within the fashion sphere was the Calvin Klein men's underwear campaign, which ran during 2002–2003 and used an obscure young surfer, Travis, rather than a well-known model or a famous figure. Research showed that although women responded very positively to his image, men found his long hair and soft features off-putting. He was replaced in the Autumn 2003 campaign by the Arsenal soccer star, Fredrik Ljungberg, who has a more macho image—his hair is shaved, he wears a medallion, and the pictures all show clearly the large black panther tattooed on his lower abdomen.

Interestingly, despite the growing popularity of sports over the past century, fashion advertising was relatively slow to involve sportsmen and women. Things changed during the 1980s and 1990s—arguably Nike owes its global dominance to its use of the basketball star Michael Jordan, and more recently they have used international footballers such as Edgar Davits. The tennis stars Venus and Serena Williams have appeared on magazine covers and lent their names to sportswear, while the Russian Anna Kournikova was used for a Berlei bra campaign with the tag line "Only the balls should bounce."

The most notable development within the 1990s, however, has been the link forged between fashion and soccer. Eric Cantona appeared on the catwalk for John Paul Gaultier, while younger stars have modeled in men's fashion magazines. David Beckham's enormous popularity has meant that he has moved from fashion-related advertising—sunglasses, watches, children's clothes—and magazine shoots to becoming a global brand in himself.

He and his wife, the former Posh Spice, went on a tour of America in 2003 when their agents advised them that it was necessary, given the fact that many Americans are unfamiliar with soccer stars. He and his wife are important because they are among the new “celebrity couples” whose activities the media can chronicle and whose image is of interest. Their American counterparts are perhaps Brad Pitt and Jennifer Aniston—she was voted “The Most Popular Person in America” in the *Forbes* poll of July 2003. However, apart from Aniston’s early contract with L’Oreal, neither she nor Pitt has taken part in direct advertising. Nevertheless, they can “endorse” products simply by wearing them when snapped on the street—they have popularized Maharishi trousers and Birkenstock sandals.

Celebrities within the music industry have been courted, too, both in the 1960s and more recently. In the past singers were used in fashion spreads or asked to lend their name to a range of merchandise—now they are directly approached by leading fashion brands to join film stars in rendering “luxury brands” more democratic. Donna Karan used Bruce Willis, action-man hero, in the 1990s, while Madonna modeled Tom Ford’s early designs for Gucci. She also appeared in a Versace campaign photographed by Herb Ritts—but recently she has lent her celebrity to the high street, in a Gap television commercial with Missy Elliott. The high-fashion brands have tried to widen their appeal through the use of singers such as Christina Aguilera, in the Versace campaign for Autumn 2003, and Jennifer Lopez, used by Louis Vuitton in the same season. At the same moment, Tommy Hilfiger announced that he wanted to create a new image for his sportswear and had recruited the musician David Bowie and his wife, the ex-model Iman, currently working for Bulgari. Hilfiger sportswear is currently popular among the young and has some “street credibility”—this latest celebrity appointment suggests an attempt to interest forty-somethings in his sportswear, based perhaps on the success of Juicy Couture tracksuits after Madonna and Jennifer Lopez were photographed wearing them. Rap stars have been courted assiduously in an attempt to gain the kind of appeal Hilfiger’s range possesses; the singer P. Diddy has launched a collection of casual wear, Sean Jean—while in another attempt to give expensive brands a broader appeal, Missy Elliott has been used as the face of Garrards, the royal jewelers.

This new reliance on celebrities for high-fashion endorsement is not worrying in itself—what is problematic, both within the industry and, more importantly, in a wider sociological context, are the sociological and psychological implications of celebrity obsession. It is tempting and not too far-fetched to suggest that the current climate owes much to the life—and unfortunate death—of Diana, Princess of Wales. In the early 1980s, she was far from being a glamorous fashion icon—and it was this perceived “ordinariness” that made her so appealing to the press at first. She had a haircut and a taste for frilly blouses that

set trends precisely because this Earl’s daughter seemed to the public to be “one of them,” however false that assumption was. Her experiments with different hairstyles and her fashion education—she received guidance from the staff of British *Vogue*—were avidly followed. So too was the developing drama within her personal life. She featured in newspapers worldwide, and magazine editors found that her face on a cover guaranteed sales. Her battles with her weight—and her admission of her bulimia—were chronicled as carefully as the problems within her private life. When she died, the scenes in England were both extraordinary and unprecedented.

Arguably, the public had developed over two decades a need, even a craving, for celebrity worship—and the press has responded. The current pathological interest in body image, with its accounts of the different diets and fitness regimes followed by particular celebrities, seems to be spiraling out of control. And certainly in Britain, there is concern about the size of individual credit-card debt. A recent survey showed that the average woman now spends far more on shoes than in the past, and this is possibly linked to the fact that “Manolos” have become a household name through the television program “Sex and the City.” They were worn not only on-screen by the heroine, Carrie Bradshaw, but by the actress Sarah Jessica Parker, who herself became a style icon. The new attempts to copy star images, decor, and lifestyle, the hours spent scouring celebrity websites, can only make for a stifling of individuality in dress, a feeling of discontent, and, more disturbingly, an unhappiness with faces or bodies that are not perfect.

See also **Actors and Actresses, Impact on Fashion; Fashion Icons; Models; Supermodels.**

#### BIBLIOGRAPHY

- Berger, Maurice, Brian Wallis, and Simon Watson, eds. *Constructing Masculinity*. London and New York: Routledge, 1995.
- Bruzzi, Stella. “Football, Fashion and That Sarong.” In *Fashion Cultures: Theories, Explorations, and Analysis*. Edited by Stella Bruzzi and Church Gibson. London: Routledge, 2000.
- Dyer, Richard. *Stars*. London: BFI Publishing, 1986/1998.
- Gritten, David. *Fame*. London: Allen Lane, 2002.
- Hilfiger, Tommy. *Rock Style*. London: Barbican Centre, 2000.
- Macdonald, Paul. *The Star System*. London: Wallflower Press, 2000.
- Rojek, Chris. *Celebrity*. London: Reaktion Books, 2002.
- Thesander, Marianne. *The Feminine Ideal*. London: Reaktion, 1997.

Pamela Church Gibson

#### CEREMONIAL AND FESTIVAL COSTUMES

Ceremonies, festivals, and other rituals provide a structure for an individual or a group to reaffirm social values and ties. They tend to be public events, seen as different

from everyday, which spotlight an important personal or cultural happening. Ritual helps to give meaning to the world in part by linking the past to the present and the present to the future. Ritual works through the senses to structure our perception of reality and the world around us; it is often when a society's deepest values emerge in the form of activity, objects, and dress. Ceremonies often combine religious belief with social and political concerns. Although rituals tend to evolve very slowly, cultures do change over time, and possible disjunctures may develop between a ceremony and the attitudes of the society, resulting in the modification or even elimination of the ceremony. The costumes worn at these times are frequently special to the occasion and dramatically symbolic; they can reflect historical or cultural preferences that are no longer in vogue. Different stages or events characterize some celebrations, requiring many changes of costume or dress. Dress is an inclusive concept that involves modifying the body by the use of textiles, cosmetics, scars, coiffures, apparel, jewelry, and accessories held by or for a person. Although in general dress can range from temporary acts of covering and adorning to permanent acts of modification, such as scarification, ceremonial dress is usually of a temporary nature.

Unlike masquerading, dress is not meant to transform an individual into something else but to enhance the identity of the individual. In many cultures, costumes have been used in a wide range of festivals stressing community solidarity or declaring the right of a person or group to a particular status, office, or possession. Since the nineteenth century, the Zulu of South Africa have used clothing and jewelry made from imported beads to demarcate changes in status associated with different life-cycle stages. Children and married women usually wear less beadwork. Young girls attire themselves in square or rectangular beaded loincloth panels attached to a bead string; pregnant women dress in leather aprons decorated with beadwork; and married women wear a knee-length skirt made of pleated goat skin or ox hide, hoop-like circular necklaces, and a flared headdress in the shape of a crown covered with red ocher or red beads and a beaded band around its base. The color schemes of beaded necklaces convey social messages about stages of physical and social development. Small rectangles, zigzag or vertical bands, diamonds, triangles, and lozenges are the most widespread motifs.

### Rites of Passage

A rite of passage is a common ceremony that involves a transition from one status or condition to another. For an individual, these include birth, puberty, marriage, and death. Scholars usually divide this type of ritual into three stages: separation, a transitional or liminal one, and reincorporation; the latter two are most often associated with distinctive dress. For a community, annual rites of passage mark seasonal changes or cycles of renewal and regeneration. Individual and community rites of passage

serve to enhance social solidarity, confirm membership in a group, and channel any anxiety resulting from the potential dangers of the transition. Societies throughout the world institutionalize the physical and social transformation that boys and girls undergo at the time of puberty by marking their passage from childhood to adulthood. There is, however, considerable variation in the timing of the ritual, length of ritual, and age of initiate.

As part of the puberty ceremony carried out among Sepik River peoples in New Guinea, newly initiated boys enter a men's meetinghouse, the political and religious center of the community; after passing across the threshold, the boys encounter sacred cult objects that play a role in their introduction to appropriate beliefs and behavior. The young men are also given body paint in the course of initiation. After residing in the cult house for months, the boys return to their village as adults when all male members of the house elaborately decorate their bodies as a statement of their own attractiveness, to display characteristics identified with being a successful male and to identify themselves as sacred beings from the world of the ancestors. The men—dressed in fiber skirts—paint their bodies with yellow, black, red, and white curvilinear patterns. Paint is believed to be sacred and clearly adds to the seriousness of the occasion. Red and white are especially favored because these colors are associated with brightness and are viewed as auspicious. A wicker headdress adorned with flowers and feathers as well as large shells worn on the chest and forehead enhance the brilliance of the costume. In addition, other accessories of shell, bone, boar-tusk, seeds, and feathers are worn. Feathers are noteworthy for symbolizing growth and power.

In the early 2000s, the most important Apache ceremony is the girl's four-day puberty rite—sometimes referred to as the Sunrise Dance—that was taught to the Apache by White Painted Woman, an important deity in the American Southwest. A similar ritual is held by the Navajo, but the Apache put greater stress on the benefit of the ritual to the community. The ceremony is organized by a shaman hired by the girl's family who also select godparents to assist the young girl during the ceremony and throughout her life. On the second night, male masqueraders called Gan, wearing plank headdresses made of slats of agave stalk, impersonate Mountain Spirits who bless the area and help protect the community from dangers and disease. During the Apache puberty ceremony, the young girl is dressed in either a buckskin skirt or a long cotton skirt and a buckskin smock or cape painted yellow, the color of sacred pollen said to symbolize fertility. These garments are decorated with symbols of the moon, sun, and stars. Both skirt and smock utilize fringes that could represent sunbeams. An abalone shell is worn on the forehead along with shell necklaces, shell earrings, and feathers for the hair. Metal bells, buttons, and decorative metal cones cut from cans dangling from the dress have been



used since the early nineteenth century. Buckskin moccasins and leggings might be added to the ensemble. The various items of dress must be put on in a prescribed sequence and draped in a particular way. The outfit of the girl, based on traditional female dress, is now specific to this ceremony; in the past, the Apache wore various items of dress made only from animal skins. The use of an older material or clothing style for ceremonies is not uncommon.

At the time of puberty in the West African country of Sierra Leone, Mende girls begin an initiation process into the female Sande association where they learn traditional songs and dances and are educated about their future roles as wives and mothers. During seclusion, the girls are covered with a white pigment of crushed shell and chalk and wear ornaments that define their status as novice and indicate that they are under the protection of the association. Formerly, this period lasted for several months, but in recent decades, the period has been reduced to a few weeks. After successfully completing all initiation obligations, the girls with similar hairstyles and dressed in fine clothing form a procession and parade back to town accompanied by masked dancers. Sande is the only documented African association in which women both own and perform masquerades. The masks—characterized by a shiny black surface, fleshy neck rolls, delicately carved features, a smooth, high forehead, and an elaborate coiffure—are seen as expressing a Mende feminine ideal. The coiffures of the mask are actually based on popular types of Mende hairstyles, especially those worn on special occasions by women of high status. The arrangement of the hair into a series of longitudinal ridges is a common coiffure and has been documented on women at the turn of the fifteenth century; it indicates the role of women as cultivators and bearers of culture.

Elaborately painted body decoration and scarification are customarily associated with initiation ceremonies in many parts of the world. Among the We of the Ivory Coast, the faces of young female initiates are painted when they leave the excision camp by initiated women, skilled in body painting. They paint the faces of the young girls with schematic designs in black, blue, red, and white. The girls' torsos are sprinkled with oil and rubbed with snail shell or porcelain to make their bodies shine; they will also wear a woven wrapper, necklaces, and bracelets. The purpose of such embellishment is to make the girls look attractive. After emerging from the camp, the initiated girls sit in state, displaying their newly acquired social status as marriageable women. Changes in role and status have been correlated with irreversible forms of body art to emphasize the accumulative and unalterable nature of the transition. Among the Ga'anda of Nigeria, girls are given facial and body scarification to mark different stages of their transition into adulthood. This procedure begins when a girl is five or six and at each stage consists of rows of slightly raised dots that form linear

and geometric patterns. The scarification is displayed at each stage and when completed expresses the permanent nature of the transition as well as a visual identification with the group. At these times, the girls wear only a simple woven cloth apron allowing for maximum visibility of the body designs.

For centuries, the Kalabari people of southeastern Nigeria have worn an assortment of both foreign and indigenous items of dress. These they assemble into a distinctive ensemble that for women consists of an imported lace or eyelet blouse and a combination of wrappers embellished with bead, gold, or coral jewelry. The Kalabari do not produce textiles themselves, but purchase handwoven textiles made in Nigeria and Ghana along with imported, factory-made textiles. This type of composite dress is especially apparent during *iria*, a series of ceremonies that mark several stages of a woman's life. When women reach both physical and social maturity, they are allowed to tie and layer a series of short cloth wrappers around their waist to increase the bulk of their midsection, symbolizing their role as society's procreators. Textiles signify a family's wealth and are stored in special cloth boxes that are passed down from one generation to the next. The Kalabari also make use of these textiles by decorating funerary chambers of socially prominent elders with rich displays of heirloom textiles. The degree of a chamber's elaboration is directly related to the deceased's success in life. A group of elderly women, skilled in selecting and arranging textiles, completely drape the ceiling and walls with cloth. The bed, where the corpse is laid in state, is the visual focus of the chamber. Personal accessories that belonged to the deceased, such as beads, fans, canes, and textiles are folded and layered on the bed to reveal a variety of patterns, textures, and colors. The display of the family's textile collection in the funerary chambers is believed to facilitate an elder's transition from the human community to the realm of the ancestors.

Many societies or cultures associate a particular color or type of costume with mourning appropriate for wearing at funerary or memorial ceremonies. The Frafra of northern Ghana have elaborate funerary rituals that emphasize dress. The ordinary male funerary costume consists of a smock, quiver, bow, flute, and headdress. This costume, which is based on the dress worn by both hunters and warriors, symbolizes the origins of Frafra society and its early history. The most common funerary headdress, worn by any male old enough to be a hunter or warrior, is a wicker cap with a hole in the top for inserting a stick or bundle of reeds covered with the hair from the neck of a sheep. The use of sheep hair reflects the importance of domesticated animals, especially for sacrifices. Such a helmet may be made by the owner or purchased in the market. On the other hand, the wicker helmet with horns can be worn only by a hunter. The female funerary costume is based on traditional female dress. In much of northeastern Ghana, women in the past

wore woven grass waistbands with small forked leafy branches attached to the front and rear. This leaf form has been replaced almost entirely by a tail made of dyed grass or leather strands. Women would receive such elaborate “tails” during courtship as signs of admiration and intent. The grass or leather “tails” are viewed as proper dress for special occasions. Today, a commercially printed cloth for the upper torso or head tie is often added. In addition, a woman may wear stone or ivory armlets to reflect pride in her family and household.

A wedding ritual not only unites two individuals, but provides a permanent linkage between families and kin groups. Ceremonies marking marriage put considerable emphasis on elaborate and often colorful dress. In Central Asia, special garments tailored from silk cloth were worn at marriage by high-status, wealthy women during the nineteenth century. Because Central Asians viewed silk attire as accumulated wealth, dresses and robes were seen as important components of a woman’s dowry. For the marriage ceremony, women attired themselves in a series of dresses, worn in a layered manner so that the richly patterned sleeves of each dress were visibly displayed; an outer robe completed the bride’s dress ensemble. This collarless robe, which was close-fitting in the torso with a flaring outward toward the hem, was worn open in the front to reveal the bride’s brightly colored dresses; outer robes, considered the most sumptuous of all of the bride’s garments, were held in such high esteem, that one or two of them were even draped over the owner’s body during her funeral ceremony. The garments were fashioned from hand-loomed silk cloth, decorated with designs made using the ikat-dyeing technique in which the thread is tie-dyed prior to being woven. The designs were usually created through a process of tying the lengthwise or warp threads before plain colored crosswise or weft threads were woven into them. In the finished textile, the edges where the warp threads had been bound together for dyeing, show a blurred, irregular outline.

The traditional dress for a Tunisian woman consists of a silk, cotton, or wool wrapper draped around the body and attached on the chest with one or two fibulae and gathered at the waist with a sash. The wrapper is covered by a loose-fitting tunic with seams on either side and, for some, sleeves made from another more exquisite material. This type of outfit is now used only for weddings with each region having its own specific patterns and colors. Women are allowed to express their own individual taste and preference. Tunisian wedding tunics are decorated with elaborate embroidery, sequins, and gold-covered wire thread. There is an increasing emphasis on such gold work, especially in the urban areas. Embroidered designs may represent popular symbols of luck such as a star, birds, fish, and crescents. Similar tunics are found in other parts of North Africa. The wedding costumes and jewelry, which have become increasingly expensive, may be borrowed from neighboring families or rented from a fe-

male specialist who helps plan wedding ceremonies. For jewelry, silver is preferred because it is believed to be pure and propitious. Women wear a variety of tunics with different types of decoration and design at distinct ceremonies during the wedding ritual. In Tunisia an important part of the wedding ceremony is for a bride to be displayed formally to the groom, her relatives, and the relatives of the groom. At these times she is dressed in several different tunics that she removes one by one until she is in the last one, the richest of all. For North Africans, marriages represent a significant change of status and require considerable expense and attention; they last for several days and most people of the village will turn out for the event.

### Identity, Status, and Leadership

Costumes may also express cultural identity or membership in a group. For the Yoruba of Nigeria there are a number of secular occasions where dress plays a prominent role in affirming a person’s Yoruba identity. Both family and community ceremonies, including funerals, childbirth, and child-naming occasions, weddings, chieftaincy celebrations, and house-opening feasts are important social events where members of different extended families come together and dress in their finest clothing. Men wear a gown ensemble consisting of tailored gowns, trousers, and hats made from strip-woven cloth while women wear a wrapper ensemble, blouse, and a head tie. The Yoruba have a custom called *aso-ebi*, where male and female members of families and social clubs appear together in dress made of the same type of cloth. *Aso-ebi* cloth may be special-ordered or purchased at the market and when worn, it visually reinforces the group’s cohesion.

In the northwest coast of America, the confirmation of an inherited privilege or the authentication of a new rank or status occurs during a special type of public ceremony called a potlatch, which is especially well developed among the Kwakiutl, Haida, and Tlingit. A potlatch is often held over a period of days and accompanied by the display of objects and the giving of gifts to the guests. The acceptance of these gifts and the acknowledgment of their purpose are critical components of a potlatch. Although the ordinary dress of the northwest coast in the eighteenth century consisted of fairly plain cedar bark capes and blankets, when attending potlatch events, people dressed in their best clothing and seated themselves according to rank. Ceremonial garments in this area are colorful, elaborately decorated, and spectacular. A wealthy man might wear a Chilkat or button blanket, a waist robe or apron, a shirt, leggings, and a headdress, often made of woven spruce root or cedar bark. To the headdress, a carved frontlet, ermine strips, or basketry rings could be added. Trousers are currently worn under the garments. The costume of wealthy women is similar to that of men except for the substitution of a plain dress for the trousers or robe. Shredded cedar bark and mountain goat wool are used for weaving

the Chilkat blanket, considered as a family heirloom. This garment is rectangular at the top and the sides and from the bottom edge in the shape of a shallow V, there extends a long warp fringe about one-quarter the length of the blanket. The surface design is clearly a transfer from another medium (painting) and has the effect of a low relief. In addition, the curvilinear forms, characteristic of northwest coast art, is successfully achieved. Black, blue, white, and yellow are the colors that establish the patterns. A newer ceremonial covering is the button blanket consisting of a dark blue blanket—usually Hudson's Bay blanket—decorated with red flannel border and appliqué outlined in small iridescent pearl buttons. Buttons are used as well for creating the details of an image. Dentalium shells—a symbol of wealth—could also ornament a button blanket. The images are normally crest animals, such as a raven, whale, beaver, or eagle, which connect to clan myths.

Ceremonial dress associated with identity and renewal can also reflect social and political points of view or be used for other functions such as protection. Although metal armor was worn by warriors and rulers in Europe as far back as ancient times, in the fourteenth century, overlapping plates of steel were developed to produce a more effective way for covering the entire body. Since plate armor was quite expensive to make, it was limited to warriors of noble birth and became an indicator of status. During the following two centuries, knights and kings who rode into battle on horseback both protected and defined themselves with full suits of plate combat armor while providing a festive element to the occasion. For tournaments or jousting events, knights needed to wear armor made of even heavier metal and often more elaborately decorated. Armor served to protect an individual as well as to enhance appearance. Therefore, decoration, based on a variety of metalworking techniques such as embossing, engraving, and etching, expressed the wealth and status of the wearer. The most commonly used technique in decorating armor was etching.

The Great Plains of North America consisted of many tribes sharing a dependence on the buffalo as a source of food and raw materials. The standard ceremonial regalia for a Plains' warrior included a painted buffalo robe, quill shirt, leggings, moccasins, and some kind of feathered headdress. Plains ritual, which encompassed songs and special dress including body and face painting, were performed for a war campaign, a major buffalo hunt, and a community ceremony such as the sun dance, which focused on renewal. All clothing was made by women who were responsible for tanning animal skins and tailoring the various garments. For the American Plains, the buffalo robe was a distinctive type of dress, which could be painted by men with figurative designs illustrating historical events—especially military exploits—hunting scenes or, in some cases, supernatural visions. Plains cultures attached great importance to these visions and animals were frequently involved, especially buffalo, elk,

bears, eagles, and sparrow hawks. The designs, which can symbolize less visually obvious ideas, were usually arranged horizontally without any overall composition. The actual painting of a buffalo robe was the responsibility of the owner. Originally the colors, each applied with a separate brush, were made from mineral or vegetable material. Quillwork and beadwork embroidery were also employed to adorn a robe. For the people of the Plains, robes served as an expression of both individual and community exploits. A men's robe is similar in form and construction to a woman's dress except it is shorter and has full sleeves.

The symbolic power of traditional Plains clothing was acknowledged again in the late nineteenth century with the Ghost Dance movement, a revitalization movement based on a belief that the Great Spirit would clear away the wreckage of the white man, bring back the buffalo herds, and reunite the Native American people—both living and dead—in a regenerated Earth. The ceremony, which originated among the Paiutes but quickly spread north and east to other Plains groups, began either late in the afternoon or after sundown and involved a circular dance, from East to West, following the movement of the sun. Preliminary activities included painting and dressing the body that took about two hours. The painted designs were an inspiration from a trance vision and consisted of elaborate designs in red, yellow, green, or blue upon the face or a yellow line along the parting of the hair. Suns, crescents, stars, crosses, and birds (especially crows) were the designs usually associated with both painting and clothing. Stars were the most common motif and consisted of a variety of forms such as the traditional four-pointed star, the five-pointed star of the American flag, dashes of paint representing falling stars or the many stars in the heaven. It was by wearing Ghost Dance shirts and dresses that the Great Spirit would recognize his people. Both shirts and dresses were usually made of muslin or cotton but garments of elk, deer, or antelope skins were also produced. These garments were decorated with painted designs, cones, bone, quillwork, and feathers. An eagle feather was also worn on the head.

Social status in most societies is usually expressed through the display of ornaments on the body; yet for a number of cultures, the permanent modification of the skin can exhibit societal membership or high status through scar and tattoo designs. For the Maori of New Zealand, tattooing was characterized by a dense, overall, and interrelated series of motifs organized into spiral and curvilinear patterns. In general, a tattoo results from pricking or piercing the skin and then pigmenting the punctured spots with a coloring substance. Pigment made from soot mixed with spring water, light fish oil, or plant sap, was rubbed into the cut skin. The entire process usually took months or even years to complete. Facial tattooing identified a man as belonging to a particular group and indicated the magnitude of his mana or spiritual power. Although permanent, tattooing was seen as a nec-



essary item of dress for ceremonial occasions: each design had a specific name, and every tattooed individual was marked differently. People of high status had the right to be tattooed while those of lesser status had to earn that right. Wealth, position in the community, and the level of a person's courage would determine the extent and nature of the tattoos. The facial tattooing of a chief were considered so distinctive and varied that the chief would draw them at the bottom of European documents as his signature.

Frequently, leaders of the community will dress in a distinctive fashion, especially during ceremonial occasions. An individual's political power, social position, and wealth can be made visible by dress expressing prominent status or indicating particular social roles such as warrior, judge, and police officer. We must not forget that ordinary people also wear special dress for important events, including weddings, funerals, high school proms, or even gallery openings. Usually it is the entire ensemble of clothing and accessories that project authority and status. But at times, a single item of dress may announce social position and political power. For example, among the Yoruba of Nigeria, a conical, beaded crown with fringe veil is the primary symbol of kingship and must be worn by the ruler on all ceremonial occasions. The veil obscures the face of the living king while a face motif on the crown reveals the dynastic ancestors. In this way, the crown represents the spiritual and political force of the dynasty. Crowns also reference royal power in European cultures.

Royal dress and regalia has characterized the Asante people of Ghana since the seventeenth century. The two most spectacular elements of Asante dress are kente cloth and elaborate gold jewelry. Kente is a brightly colored, hand-loomed, narrow band cloth woven by men on a four-heddle horizontal loom. The weavers use silk or rayon thread to create bright color in a predominantly cotton textile. The names and meanings of kente designs can allude to proverbs, historical events, or important characteristics of leadership. During their reigns, Asante kings were expected to invent new kente designs. Kente is a good example of how a dress form that is adopted by another culture can shift meaning. In the United States, kente has become identified with African American culture and has been used in multiple forms and ceremonial contexts. The Asante have used gold extensively to adorn and glorify rulers as well as to validate their positions. The Asante king and various categories of chiefs wear many items of gold, such as necklaces, anklets, large armlets, and rings. Magnificently attired rulers, encumbered with as many gold ornaments as they can wear or carry while participating in religious or state ceremonies can be identified with the proverb "Great men move slowly." Gold objects are produced by the lost wax process or repoussé technique.

In Polynesia the spiritual power of rulers and other high-ranking people was often expressed by wearing ap-

parel made of feathers, which associated it with the gods. In Hawaii, one of the most centralized and status-conscious societies in Polynesia, feather cloaks, sashes, and helmets were important components of ceremonial dress, enhancing the authority and divine status of a ruler. Cloaks, worn on state occasions and during battle, provided spiritual, and to some extent physical, protection to the wearer. Capturing an enemy's feathered cloak was a particularly powerful symbol of defeat. The size of a cloak was directly related to the amount of power a noble person possessed. Because so many feathers were required to produce a cloak, only individuals of great wealth could afford them. Feathers were in part collected as tribute paid by commoners to the chiefs each year. Although ordinary clothing was made by women, the cloaks were made by high-ranking men. Passing a cloak to a descendant involved a transfer of mana (power) from one generation to the next. Feathered cloaks were worn wrapped around the body so that the edges come together unifying the motifs that flank each edge. Many cloaks were decorated with four yellow, bladelike motifs set against a red background. With the imposition of American rule in the late nineteenth century, feathered cloaks were no longer used for warfare but continued to be indicative of chiefly rank. Also, red feathers, associated with the god of war, were used less and yellow became more common as yellow feathers were rarer and more valuable.

A complete clothing ensemble, consisting of cloak, robe, and turban, expresses religious identity as well as high social status for the Muslim Hausa-Fulani rulers of northern Nigeria and is worn for religious celebrations and major political events. On such occasions, the lavishly dressed ruler and officials of high rank appear in a public procession, mounted on richly adorned horses, to symbolically establish superiority over those they rule. Their dress not only sets the ruling aristocracy apart from the rest of the population, but also identifies the wearer with the larger Muslim world both within Africa and beyond. Robes, the most distinct part of the dress ensemble, are often worn layered, creating an imposing image of physical bulk and majesty. The visual focus of the robe, tailored from hand-woven or factory-made cloth, is a large pocket densely embroidered with geometric designs that are loosely inspired by Islamic calligraphy and believed to offer spiritual protection to the wearer. A turban is wrapped numerous times around the wearer's head and chin, creating an aesthetic effect that visually complements the bulky robe. The turban signifies that the man has completed the most important obligation of Islam—a pilgrimage to the sacred city of Mecca. Items in a ruler's dress ensemble are valued heirlooms that belong to the state; like the feathered cloaks of Hawaiian leaders, they can be passed on to descendants in the royal line or given as gifts to other rulers and officials to seal political alliances.

Symbolic dress is not limited to other times and cultures. The dress of modern political leaders and their families shapes the public image as well. A case in point

is the wardrobe of Jacqueline Kennedy during the campaign and presidency of her husband, John F. Kennedy. Kennedy was criticized for her extravagant wardrobe and use of foreign designers—especially when compared to the plain style of the Republican candidate's wife, Pat Nixon. Soon after the election, Kennedy worked with the American designer Oleg Cassini to re-create her image. As First Lady, Kennedy established a unique style that was dignified and elegant but also photogenic and recognizable. For her husband's swearing-in ceremony in January 1961, Jacqueline Kennedy wore a Cassini-designed beige wool crepe dress. She also wore a pillbox hat from Bergdorf Goodman's millinery salon, in what was to become her trademark style—on the back of her head rather than straight and high, as was the fashion. Jacqueline Kennedy's style became widely popular and helped define the image of the Kennedy presidency as innovative, dynamic, and glamorous.

Viewed globally, ceremonial dress involves many acts of body modification that reflect both indigenous development and outside influences. As cultural artifacts, the specific elements of apparel and body adornment have many aspects of meaning; they serve as vehicles for the expression of values, symbols of identity and social status, and statements of aesthetic preference. Each item of a costume has its own history and sociocultural significance and must be considered along with the total ensemble. By looking at ceremonial costumes in other cultures, it becomes possible to understand better the form and function of similar types of dress in one's own culture.

See also **Carnival Dress; Kente; Masks; Masquerade and Masked Balls.**

#### BIBLIOGRAPHY

- Adams, Monni. "Women's Art as a Gender Strategy among the Wé of Canton Boo." *African Arts* 26, no. 4 (1993): 32–43.
- D'Alleva, Anne. *Art of the Pacific*. London: Calmann and King Ltd., 1998.
- Eicher, Joanne B., and Tonye V. Erekosima. "Final Farewells: The Fine Art of Kalabari Funerals." In *Ways of the River: Arts and Environment of the Niger Delta*. Edited by Martha G. Anderson and Philip M. Peek, 307–329. Los Angeles: UCLA Fowler Museum of Cultural History, 2002.
- Jonaitis, Aldona, ed. *Chiefly Feasts: The Enduring Kwakiutl Potlatch*. New York: American Museum of Natural History, 1991.
- Mack, John, ed. *African Arts and Cultures*. London: British Museum Press, 2000.
- Perani, Judith, and Fred T. Smith. *The Visual Arts of Africa: Gender Power and Life Cycle Rituals*. Upper Saddle River, N.J.: Prentice Hall, 1998.
- Rose, Roger G., and Adrienne L. Kaepler. *Hawai'i: The Royal Islands*. Honolulu, Hawaii: Bishop Museum Press, 1980.
- Ross, Doran. *Wrapped in Pride: Ghanaian Kente and African American Identity*. Los Angeles: UCLA Fowler Museum of Cultural History, 1998.

Rubin, Arnold, ed. *Marks of Civilization*. Los Angeles: UCLA Fowler Museum of Cultural History, 1988.

Spring, Christopher, and Julie Hudson. *North African Textiles*. London: British Museum Press, 1995.

Turner, Victor, ed. *Celebration: Studies in Festivity and Ritual*. Washington, D.C.: Smithsonian Institution Press, 1982.

Fred T. Smith

**CHADOR** Chador, meaning "large cloth" or "sheet" in modern Persian, refers to a semicircular cloak, usually black, enveloping the head, body, and sometimes the face (like a tent), held in place by the wearer's hands. It is worn by Muslim women outside or inside the home in front of *namabram*, men ineligible to be their husbands, in Iran and with modifications elsewhere, including parts of Afghanistan, Iraq, and Pakistan. The chador is closely associated with the Islamic practice of *hijab*, which comes from the verbal Arabic word "hajaba," meaning to hide from view or conceal. *Hijab* stresses modesty based on Koranic passages (Surahs XXXIII:59 and XXIV:13) indicating that believing women should cover their hair and cast outer garments over themselves when in public.

#### Hijab and Politics

The Islamic chador, introduced during the Abbasid Era (750–1258) when black was the dynastic color, has been worn by Persian women with slight variations over many centuries. Western sartorial changes began in Iran during the reign of Shah Nasir al-Din (1848–1896) who, after visiting Paris in 1873, introduced European-style clothing to his country. The chador, however, was still worn by most Persian women. After World War I, with the government takeover in 1925 by Reza Khan Pahlavi, legislative and social reforms were introduced, including using the modern national state name "Iran." Influenced by Ataturk's Westernization clothing programs in the new Republic of Turkey, Reza Shah hoped his people would be treated as equals by Europeans if they wore Western clothing. His Dress Reform Law mandated that Persian men wear coats, suits, and Pahlavi hats, which resulted in compliance by some and protesting riots by others with encouragement from ulema, the group of Islamic clerics known as mullahs. Gradually, the traditional *Shari'a*, or Islamic Law, was being replaced by French secular codes. Because of emotional and religious opposition to unveiling women, the shah moved slower regarding female dress reforms, but by February 1936, a government ban outlawed the chador throughout Iran. Police were ordered to fine women wearing chadors; doctors could not treat them, and they were not allowed in public places such as movies, baths, or on buses. As modern role models, the shah's wife and daughters appeared in public unveiled.

In 1941, fearing a Nazi takeover during World War II, British and Soviet troops occupied Iran, whereby Reza Shah abdicated in favor of Mohammed Reza, the crown prince, age twenty-two, who agreed to rule as a constitu-



**A Muslim woman wears a black *chador*.** The garment is a semicircular cloak covering the head, body and sometimes the face. Women are required to wear the chador outside and also inside the home in front of men other than their husbands. MARY FARAHNAKIAN. REPRODUCED BY PERMISSION.

tional monarch. Attempting to placate both pro- and anti-chador advocates, the young shah removed government restrictions prohibiting wearing chadors, but asked Muslim leaders to call for tolerance toward women who chose to appear publicly unveiled. The chador controversy continued over several decades: some pro-Marxist, anti-Western groups opposed the shah and advocated the chador; pro-Westerners wanted European-style clothing. Ultimately, the chador came to symbolize “rebellion” against the regime, until finally in March 1979, after the shah’s forced departure, the opposition leader Ayatollah Khomeini returned from exile, taking over government control. His pro-Islamic revolutionary policies included urging women to resume wearing the chador for modesty reasons. Reacting to large protest marches, government officials clamped down, ordering all women in government employment to wear the chador. By May 1981, legal reforms based on Islamic *Shari’a* required all women over age nine to observe *hijab*, wearing either the chador or a long coat with sleeves and a large dark head cloth. These legal regulations were still in effect in the early 2000s.

See also **Islamic Dress, Contemporary; Middle East: History of Islamic Dress; Religion and Dress.**

#### BIBLIOGRAPHY

- Baker, Patricia L. “Politics of Dress: The Dress Reform Laws of 1920/30s Iran.” In *Languages of Dress in the Middle East*. Edited by Nancy Lindisfarne-Tapper and Bruce Ingham. Surrey, U.K.: Curzon Press, 1997.
- El Guindi, Fadwa. *Veil: Modesty, Privacy and Resistance*. Oxford, U.K.: Berg, 1999.
- Scarce, Jennifer M. “The Development of Women’s Veils in Persia and Afghanistan.” *Costume* 9 (1975): 4–14.
- Shirazi, Faegheh. *The Veil, Unveiled: the Hijab in Modern Culture*. Gainsville: University Press of Florida, 2001.

Beverly Chico

**CHALAYAN, HUSSEIN** Hussein Chalayan’s fascination with architecture, spatial dynamics, urban identity, and aerodynamics is expressed in garments based on concepts, technological systems, historical dress, and theories of the body. His clothes are minimal in look but maximal in thought.

#### Early Career

Chalayan was born in the Turkish community of Nicosia on the island of Cyprus in 1970. His parents separated when he was a child. At the age of eight, he joined his father, who had moved to the United Kingdom. Chalayan was sent to a private school in London when he was twelve, but returned to Cyprus to study for his A-level examinations. He went back to London and attended Central Saint Martin’s College at the age of nineteen to study fashion. Chalayan rose to fashion fame soon after he received his B.A. degree from Central Saint Martin’s in 1993. His graduating collection, titled *The Tangent Flows*, was the now infamous series of buried garments that were exhumed just before the show and presented with a text that explained the process.

The rituals of burial and resurrection gave the garments a dimension of reference to life, death, and urban decay in a process that transported the garments from the world of fashion to the kingdom of nature. Since then, Chalayan has collaborated with architects, artists, textile technologists and aerospace engineers; has won awards; and has been recognized as an artist in numerous museum presentations of his work.

The genius of Chalayan’s work lies in his ability to explore visual and intellectual principles that chart the spectral orientations of urban societies through such tangibles as clothing, buildings, vehicles, and furniture and through such abstractions as beauty, philosophy and feeling. Chalayan’s *Aeroplane* and *Kite* dresses (autumn–winter 1995) used the spatial relationship between the fabric and the body to reflect the relative meanings of speed and gravity. The dresses became dynamic interfaces between the human body and its surroundings; the





**A model steps into a Hussein Chalayan skirt.** Chalayan incorporated a relation to architecture, geometry, and urban life into his designs. He launched his career in 1993 with a collection titled “The Tangent Flows,” in which the garments had been buried and exhumed before the show, which depicted the process of life and death. AP/WIDE WORLD PHOTOS. REPRODUCED BY PERMISSION.

Kite dress actually flew and was reunited with its wearer when it returned to earth.

In Chalayan’s eyes, all garments are externalizations of the body in the same way that vehicles and buildings are proportioned to contain the human form. “Everything around us either relates to the body or to the environment,” Chalayan explained. “I think of modular systems where clothes are like small parts of an interior, the interiors are part of architecture, which is then a part of an urban environment. I think of fluid space where they are all a part of each other, just in different scales and proportions” (Quinn, p. 120). These sentiments were amplified in the *Echoform* collection (autumn–winter 1999) in dresses that mimicked airplane interiors. Chalayan attached padded headrests to the shoulders of the garments, evoking thoughts on the role of clothing as a component of a larger spatial system.

Likewise, the *Geotrophics* collection (spring–summer 1999) made chairs into wearable extensions of the human

form. The chair dresses represented the idea of a nomadic existence facilitated by living within completely transportable environments. Determined to express “how the meaning of a nation evolves through conflict or natural boundaries,” Chalayan explored the body’s role as a locus for the construction of identity, highlighting the ways in which its appropriation by national regimes would orient and indoctrinate it according to the space in which it “belongs.”

The relationship between space and identity was further explored in the groundbreaking *After Words* (autumn–winter 2000) collection. Chalayan based the collection on the necessity of evacuating one’s home during wartime and having to hide possessions when a raid was impending. The theme evoked the 1974 Turkish military intervention that displaced both Turkish and Greek Cypriots from their homes and led indirectly to Chalayan’s emigration to Britain several years later. The collection introduced the idea of urban camouflage through clothing, whereby fashion functions as a means of hiding objects in obvious places. *After Words* featured dresses-cum-chair covers that disguised their role as fashionable garments while simultaneously concealing the furniture beneath them. The collection included a table designed to be worn as a skirt, with chairs that were transformed into suitcases and carried away by the models.

For his before minus now collection (spring–summer 2000), Chalayan returned to the architectural theme expressed in *Echoform* and *Geotrophics*, designing a series of dresses in collaboration with an architectural firm. The dresses featured wire-frame architectural prints against static white backgrounds generated by a computer program designed to draw three-dimensional perspectives within an architectural landscape. The renderings’ geometric dimensions suppress the depiction of real space and create a reality independent of the shapes and textures found in the organic world. Such absolute symmetry and concise angles create the illusion of a realm that is carefully ordered and controlled, yet the architectonic expressions correspond to physical registrations of surfaces and programmatic mappings.

The *Remote Control Dress*, which was commissioned in 2000 by Judith Clark Costume in London, was designed by means of the composite technology used by aircraft engineers, mirroring the systems that enable airplanes to fly by remote control. Crafted from a combination of fiberglass and resin, the dress was molded into two smooth and glossy pink-colored front and back panels fastened together by metal clips. The facade-like structure of the dress forms an exoskeleton around the body, arcing dramatically inward at the waist and outward in the hip region, echoing the silhouette produced by a corset. This structure gives the dress a well-defined hourglass shape that incorporates principles of corsetry into its design, emphasizing a conventionally feminine shape while creating a solid structure that simultaneously masks undesirable body proportions.

### Chalayan's Importance

While Chalayan's work continues to question traditional readings of dress and to generate exciting interdisciplinary collaborations, he also opens new frontiers for other designers to explore. As many of his groundbreaking ideas begin to influence wider trends, Chalayan's work is gaining recognition in the mainstream fashion market while continuing to receive acclaim in fashion circles. Since Chalayan signed a licensing agreement with the Italian manufacturing company Gibo in 2002, his label has grown into a strong retail brand. The designer's appointment as creative director of fashion for the classically inclined British luxury retailer Asprey brings his conceptual oeuvre to a wider public. But the garments still require an audience with the confidence to carry off clothes heavy with the thought processes behind them.

See also **Fashion Designer; Fashion and Identity; Fashion Shows; Haute Couture.**

### BIBLIOGRAPHY

Frankel, Susannah. *Fashion Visionaries: Interviews with Fashion Designers*. London: V and A Publications, 2001.

Quinn, Bradley. *The Fashion of Architecture*. Oxford: Berg, 2003.

Bradley Quinn

**CHANEL, GABRIELLE (COCO)** Gabrielle Chanel (1883–1971) was born out of wedlock in the French town of Saumur in the Loire Valley on 19 August 1883 to Albert Chanel, an itinerant salesman, and Jeanne Devolle. Her parents were finally married in July of 1884. Her mother died of asthma at the age of thirty-three. When Chanel was just twelve years old, she was sent along with her two sisters to an orphanage at Aubazine. During the holidays the girls stayed with their grandparents in Moulins. In 1900 Chanel moved there permanently and attended the local convent school with her aunt Adrienne, who was of a similar age. Having been taught to sew by the nuns, both girls found work as dressmakers, assisting Monsieur Henri Desboutin of the House of Grampyre.

### Early Career

Chanel sang during evening concerts at a fashionable café called La Rotonde. It is believed that her rendition of the song "Qui qu'a vu Coco dans le Trocadéro" earned her the nickname "Coco." Chanel started to mix in fashionable circles when she went to live in 1908 with Étienne Balsan, who bred racehorses on his vast estate at La Croix-Saint-Ouen. Chanel's astute choice of clothing—her neat tailor-made suits and masculine riding dress—and modest demeanor served to mark her out from the other courtesans. Thus from an early age Chanel demonstrated great confidence in her own sense of style, a formula that proved irresistible to other women. Soon Balsan's friends asked her to make them copies of the boater hats that she trimmed and wore herself. Seizing upon this opportunity for financial independence, in

1908–1909 Chanel persuaded Balsan to let her use his Paris apartment at 160, boulevard Malesherbes to set up a millinery business. She employed a professional milliner and she engaged her sister Antoinette and two other assistants as the business grew.

While Chanel was in Paris, her friendship with the millionaire entrepreneur and polo player Arthur Capel, known as "Boy," developed into love. It was Boy who lent her the money to rent commercial premises on the rue Cambon—where the House of Chanel was still located in the early 2000s—in the heart of Paris's couture district. Chanel modes opened at 21, rue Cambon in 1910. From the outset, Chanel was the perfect model for her own designs, and she was photographed for the fall 1910 issue of the magazine *Le théâtre: Revue mensuelle illustrée*. By 1912 hats by Chanel appeared in the popular press, worn by such leading actresses of the day as Lucienne Roger and Gabrielle Dorziat. Chanel had achieved financial independence. The terms of her lease, however, prevented her from selling clothes, as there was a dressmaker already working in the building.

### First Collections, 1913–1919

While on vacation in Deauville on the west coast of France in the summer of 1913, Boy Capel found a shop for Chanel to open on the fashionable rue Gontaut-Biron, and it was here that she presented her first fashion collections. With the outbreak of World War I in July 1914, many wealthy and fashionable Parisians decamped to Deauville and shopped at Chanel's boutique. It is believed that she sold only ready-to-wear clothing at this date. Chanel had cut her hair short during this period and many other women copied her bobbed hairstyle as well as bought her clothes. Chanel's time had come: radical in their understatement, her versatile and sporty designs were to prove perfect for the more active lives led by many wealthy women during wartime.

In 1916 Chanel purchased a stock of surplus jersey fabric from the manufacturer Rodier, which she made into unstructured three-quarter-length coats belted at the waist and embellished with luxurious fabrics or furs, worn with matching skirts. That fall Chanel presented her first complete couture collection. The March 1917 issue of *Les élégances parisiennes* illustrates a group of jersey suits by Chanel, some of which are delicately embroidered, while others are strictly plain and accessorized with a saddlery-style double belt. All are worn with open-neck blouses with deep sailor collars. A 1918 design consisted of a coat of tan jersey banded with brown rabbit fur, with a lining and blouse of white-dotted rose foulard: this matching of the coat lining to the dress or blouse was to become a Chanel trademark. Striking in their simplicity and modernity, Chanel's jersey fashions caused a sensation.

While Chanel's daywear was characterized by its stylish utility, her evening wear was unashamedly romantic. In 1919 she presented fragile gowns in black



**Karl Lagerfeld.** Lagerfeld appears with models at the presentation of Chanel's 2002 spring-summer haute couture collection. Lagerfeld became chief designer of Chanel in 1983 and was credited with making Chanel goods highly desirable again. AP/WIDE WORLD PHOTOS. REPRODUCED BY PERMISSION.

Chantilly lace with gold-spun net and jet tassels and other gowns in silver lace brocade. Capes of black velvet adorned with rows of ostrich fringe revealed a Spanish influence—the very height of fashion that winter. This was the year that Chanel would announce, “I woke up famous,” but it was also the year that Boy Capel was killed in an automobile accident.

### The 1920s

**Fashions of the early 1920s.** From 1920 to 1923 Chanel conducted a liaison with the grand duke Dmitri Pavlovitch, grandson of Russia's Tsar Alexander II, and her collections during these years were imbued with Russian influences. Particularly noteworthy were loose shift dresses, waistcoats, blouses, and evening coats made in dark and neutral colors with exquisite, brightly colored, folkloric Russian embroideries stitched by exiled aristocrats. In 1922 Chanel showed long, lean, belted blouses based on Russian peasant wear.

By 1923 she had further simplified the cut of her clothes and offered fewer brocaded fabrics, while her em-

broideries—red and beige were favorite colors that year—displayed more restrained and modernistic designs. Chanel led the international trend toward shorter hemlines. Her premises on the rue Cambon, which had already expanded in 1919, grew to include numbers 27, 29, and 31 during the early 1920s.

**Perfumes.** Chanel launched her first perfume, Chanel No. 5, in 1921. Reputedly named for the designer's lucky number, No. 5 was blended by Ernest Beaux, who used aldehydes (an organic compound which yields acids when oxidized and alcohols when reduced) to enhance the fragrance of such costly natural ingredients as jasmine, the perfume's base note. Chanel designed the modern pharmaceutical-style bottle and monochrome packaging herself. Chanel No. 5 was the first perfume to bear a designer's name. Building upon the success of No. 5, Chanel introduced Cuir de Russie (1924), Bois des Îles (1926), and Gardénia (1927) before the end of the decade.

**La garçonne.** Chanel's interpretation of masculine styles and sportswear—her blazers, waistcoats, and shirts with cufflinks, as well as her choice of fabrics—were greatly inspired by the garments worn by the duke of Westminster (an Englishman with whom she was involved between 1923 and 1930) and his aristocratic friends. Following a fishing holiday in Scotland, she introduced her customers to Fair Isle woolsens and tweeds. The duke bought her a mill to secure exclusive fabrics for her new styles. Chanel was also inspired by humbler items of masculine apparel, including berets, reefer jackets, mechanics' dungarees, stonemasons' neckerchiefs, and sailor suits, which she rendered utterly luxurious for her wealthy clients. Chanel herself often wore loose sailor-style trousers, flouting the rules of sartorial etiquette that generally restricted women from wearing trousers to the beach or within the home as evening pajamas.

In 1927 *Vogue* recommended Chanel's jersey suit in soft tan wool, with collar, cuffs, blouse, and jacket lining in rose jersey, for the woman who wanted to look chic on board ship. The long-line jacket buttoned diagonally, while the skirt was box-pleated at the front. Throughout her career Chanel paid great attention to the cut of her sleeves, ensuring that they permitted the wearer to move with ease without distorting the lines of the garment. By the fall of 1929 her sports costumes were still slim but longer, with hemlines reaching below the calf.

**The little black dress.** Chanel had designed black dresses as early as 1913, when she made a black velvet dress with a white petal collar for Suzanne Orlandi. In April 1919 British *Vogue* reported that “Chanel takes into account the lack of motors and the general difficulty of living in Paris just now by her almost invariably black evening dresses” (p. 48). But it was not until American *Vogue* (1 October 1926) described a *garçonne*-style black day dress as “The Chanel ‘Ford’—the frock that all the world will wear” (p. 69) that the little black dress took the fashion world by storm. And although the use of black in fash-



ion has a long history, Chanel has been credited as its originator ever since.

**Theatrical costume.** The stage was a prominent showcase for fashion designers during the nineteenth and early twentieth centuries. Chanel always moved in artistic circles, and she often supported the work of her friends both financially and by working collaboratively with them. In 1922 she designed Grecian-style costumes in coarse wool for Jean Cocteau's adaptation of Sophocles's *Antigone*; the designs were featured in French *Vogue* (1 February 1923). The following year she dressed the dancers of the Ballets russes in jersey bathing costumes and sports clothes similar to those seen in her fashion collections for the modern-realist production *Le train bleu* (1924). And in 1926 the actresses in Cocteau's *Orphée* were dressed head to toe in Chanel's latest fashions.

**Jewelry.** Chanel believed the role of jewelry was to decorate an ensemble rather than to flaunt wealth, and she challenged convention by wearing heaps of jewelry, often precious, during the day—even for sailing—while for evening she sometimes wore no jewelry at all. The loose, straight-cut shapes of Chanel's fashions and her use of many plain fabrics provided the perfect foil for the lavish costume jewelry that she introduced in the early 1920s. Lacking any desire to replicate precious jewels, Chanel's designs, initially made by Maison Gripoix, defied nature in their bold use of color and size. In 1924 she opened her own jewelry workshop, which was managed by the comte Étienne de Beaumont. Beaumont designed the long chains with colored stones and cross-shaped pendants that became a classic of her house. Chanel was fond of Byzantine crosses, and she was also inspired by the buttons, chains, and tassels of military costumes.

Her oversized fake pearls, worn in multiple strands, were an instant success. In 1926 Chanel created a vogue for mismatched earrings by wearing a black pearl in one ear and a white one in the other. In 1928 she introduced diamond paste jewelry and in 1929 offered "gypsy" necklaces—triple strands of red, green, and yellow beads, as well as colored beads combined with chunky wooden chains.

**Fashions of the later 1920s.** By the late 1920s Chanel's fashions were adorned with geometric designs. For daywear she used stripes and checks as well as patterns inspired by Fair Isle knitwear; for evening many of her black lace fabrics were combined with metallic, embroidered, or beaded laces.

At the height of her fame and with the demand for Paris couture at its peak, Chanel employed between two and three thousand workers during the mid- to late 1920s. She was said, however, to be a hard taskmaster and to pay poor wages. In 1927 she opened her London house. British *Vogue* pointed out in early June 1927 that, while the conception and feel of Chanel's current collection was essentially French, the designer had adapted



**Gabrielle Coco Chanel.** Chanel began designing at the beginning of the twentieth century, quickly gaining the attention of the fashion world with her stylishly functional daywear and her elegant evening wear. © CONDÉ NAST ARCHIVE/CORBIS. REPRODUCED BY PERMISSION.

it for London social life. For the Royal Ascot racing meet she offered a long-sleeved black lace dress with trailing scarf detail and, for presentation at court, an understated white taffeta dress with a train that was cut in one piece with the skirt, complemented by a simple headdress based on the Prince of Wales feathers. In September 1929 *Vogue* wrote, "When Chanel, the sponsor of the straight, chemise dress and the boyish silhouette, uses little, rippling capes on her fur coats and a high waist-line and numerous ruffles on an evening gown, then you may be sure that the feminine mode is a fact and not a fancy" (p. 35).

In tune with her modernist fashion aesthetic, Chanel installed faceted glass mirrors in her Paris couture salon around 1928. These mirrors brought the advantage of allowing her to sit out of sight to watch her shows. In complete contrast to the salon, her private apartment on the third floor of 31, rue Cambon was lavish and ornate. It is now carefully preserved, decorated with Coromandel screens, Louis XIV furniture, Venetian mirrors, black-amoor sculptures, and smoked crystal and amethyst chandeliers. When designing clothes, Chanel would pare away the nonessentials for the sake of the wearer's comfort; when designing domestic interiors, on the other hand, she believed that clutter was a necessity—that it was essential to be surrounded by the objects one needed and loved.

### The 1930s

**Fashions of the early 1930s.** Although Chanel's business may have suffered during the depression—she is said to have halved her prices in 1932—her workforce increased to around four thousand employees by 1935. Chanel's saleswomen as well as her seamstresses went on strike in June 1936 to protest their poor wages and working conditions. In April 1936 the French people voted in a left-wing coalition government headed by Leon Blum, which was followed by a number of strikes including the workers at Chanel. Chanel refused to implement the Matignon Agreement, which introduced wage increases of 7 to 15 percent, the right to collective bargaining and unionize, a 40-hour week and a 2-week paid annual holiday. Instead she fired 300 women who refused to leave the building and only later, in order to produce her next collection, agreed to introduce a workers co-operative on the understanding that she managed it (Madsen, p. 216).

From 1930 Chanel's hemlines became longer and were slightly flared; she emphasized her waists, and her jackets had soft, bloused bodices. Bows were to become a signature motif, used as decorative details on the shoulders and skirts of her garments. Cravat bows provided a feminine touch to her blouses, and crisp white frills were added around the collars and cuffs of her black suits and dresses. From 1934 Chanel used American elasticized fabrics made with a brand of yarn with a latex core called LasteX in her collections to create clothes with a crepe-like surface, and she frequently combined these with jersey.

During the 1930s she launched her cosmetics line and introduced a new perfume called Glamour. She further boosted her revenue by endorsing other manufacturers' products and designing for other companies. In 1931 she promoted Ferguson Brothers' cottons—her spring collection included cotton evening gowns—and she designed knitwear for Ellaness and raincoats for David Mosley and Sons. She also earned \$2 million for her work in Hollywood that year.

**Screen and stage.** When hemlines dropped in 1929, Hollywood's movie studios were devastated, as thousands of reels of film were instantly rendered old-fashioned. Rather than continue to follow Parisian fashions slavishly, the studio magnate Samuel Goldwyn invited Chanel to design costumes directly for his leading female stars, including Greta Garbo, Gloria Swanson, and Marlene Dietrich. Chanel, however, produced designs for just three Metro-Goldwyn-Mayer productions: *Palmy Days* (1931), *Tonight or Never* (1931), and *The Greeks Had a Word for Them* (1932). Many actresses refused to have Chanel's style imposed on them, and her designs were either overlooked or criticized for being too understated for the screen.

In Paris, Chanel continued to design for progressive plays, providing costumes for Cocteau's *La machine infernale* (1934) as well as *Les chevaliers de la table ronde* and *Oedipe-Roi*, both of which appeared in 1937. In addition,

despite her dislike of left-wing politics, she created the costumes for Jean Renoir's radical film *La marseillaise* and for *La règle du jeu*, both produced in 1938.

**Jewelry.** In 1932 the International Guild of Diamond Merchants commissioned Chanel to design a collection of diamonds set in platinum called Bijoux de Diamants. Having designed fake jewels during affluent times, Chanel now declared that diamonds were an investment. Along with her current lover, Paul Iribe, she presented a line of jewelry based on the themes of knots, stars, and feathers. The collection was exhibited in her own home in the rue du Faubourg-Saint-Honoré in Paris.

During the 1930s, Fulco di Santostefano della Cerda, duc di Verdura, started to design jewelry for Chanel. He had been designing textiles for her since 1927. Most significantly, di Verdura pioneered the revival of baked enamel jewelry: his chunky, baked enamel bracelets inset with jeweled Maltese crosses were particularly successful. Christian Bérard also designed occasional pieces for her, and Maison Gripoux continued to make up many of her designs—notably those in romantic floral and rococo-revival styles. From the mid- to late 1930s Chanel's heavy triangular bibs of colored stones and coins and her silk cord necklaces with tassels of brilliantly colored stones showed influences from India and Southeast Asia.

**Fashions of the later 1930s.** Chanel's daywear continued to be characterized by its simplicity, but—perhaps surprisingly—she participated in the vogue for Victorian-revival styles, presenting cinch-waisted, full-skirted, and bustle-backed evening gowns worn with shoulder-length lace gloves and floral accessories. Decidedly more modern was the trouser suit worn by the fashion editor Diana Vreeland in 1937–1938 that consisted of a black bolero-style jacket and high-waisted trousers entirely covered with overlapping sequins. The metallic sheen of the sequins contrasted with a soft cream silk chiffon and lace blouse with ruffled neckline and fastened with pearl buttons. Chanel's dramatic combinations of black with white or scarlet remained popular. In the late 1930s her evening wear revealed influences from gypsy and peasant sources: skirts in multicolored taffetas, sometimes striped or checked, and worn with puff-sleeved, embroidered blouses.

**The war years.** Chanel closed her fashion house during World War II but continued to sell her perfumes. For the duration of the war she lived in Paris at the Hotel Ritz with her German lover, an officer in the German army named Hans-Gunther von Dincklage. When Paris was liberated in 1944, Chanel fled to Switzerland and did not return to the rue Cambon for almost a decade.

### The 1950s

**Fashions of the 1950s.** Chanel started working again at the age of seventy in 1953, partly to boost her flagging perfume sales. Her fashion philosophy remained unchanged: she extolled function and comfort in dress and

declared her aim of making women look pretty and young. On 5 February 1954 she presented her first post-war collection, a line of understated suits and dresses. The general press response, however, was that Chanel was too old and out of touch with the modern market, and only a few models sold. On the other hand, American *Vogue* (15 February 1954) thought “the great revolutionist” sufficiently important to justify a three-and-a-half-page article devoted to her career and fashion philosophy: “A dress isn’t right if it is uncomfortable. . . . A dress must function; place the pockets accurately for use, never a button without a button-hole. A sleeve isn’t right unless the arm moves easily. Elegance in clothes means freedom to move freely” (American *Vogue*, p. 84).

By modernizing the formulas that had brought her so much success earlier in her career, Chanel succeeded in reestablishing herself as a fashion designer of international stature. For spring–summer 1955 she presented a gray jersey suit consisting of a softly-fitted jacket complete with pockets and a full box-pleated skirt, worn with a bow-tied white blouse. Navy jersey suits had school-girl-style blazer jackets and were banded with white trim or worn with knitwear striped in navy and white. Buttons were often covered in fabrics that matched the suit, and sometimes meticulously trimmed with the contrasting fabric that was used to outline the pockets and form the attached shirt cuffs. Other buttons were molded in bold brass, sometimes featuring a lion’s head—Chanel’s birth sign was Leo—or made in more delicate gilt, perhaps with a cutwork floral motif.

In 1957 Chanel introduced braid trimmings to her cardigan-style jackets. For fall–winter 1957–1958 her suits had a wrap pleat that ran down the side of the skirt and concealed a trouser-style pocket. Unusually, she showed a hat with every model—these were upturned sailor-style hats made in soft fabrics that matched the suits with which they were worn. As always, she paid great attention to the linings of her coats and suits: this season, camel hair was lined with red guanaco, gray tweed with white squirrel, and red velour with fluffy gray goatskin. Her coats were cut in the same style as her suit jackets, simply lengthened to the same level as the skirt hem.

Chanel’s modern suits in nubby wools, tweeds, or jersey fabrics with their multiple functional pockets, teamed with gilt chains and fake pearl jewelry; her distinctive handbags; and her sling-back shoes with contrasting toe caps, became fashion staples for the affluent. And as before, her designs were widely copied for the mass market: the company sold toiles to the British chain store Wallis so that it could legitimately reproduce Chanel’s designs.

For evening Chanel offered variations on her suits in such lavish materials as gold-trimmed brocade, and she remained faithful to her love of black-and-white laces for dresses. A cocktail dress from the spring–summer 1958 collection had a bodice of navy-and-white-striped silk with a



“The maison Chanel might be called the ‘Jersey House’, for the creations of Mlle. Chanel have long been and long will be in jersey. Of late, a thin firm quality of cotton velvet has been used by Chanel for cloaks and certain frocks.” (British *Vogue*, early October 1917, p. 30).

large bow at the neckline and a full skirt of white organdy, banded at the hem with the same striped fabric.

For spring–summer 1959 she presented a black lace dress, dipping low at the back and molded to the hipline, which was threaded with black ribbon and flared into a full skirt; it was accessorized with a long chain with linked pearls and chunky, colored stones. That season the collection was modeled by the designer’s friends—stylish young women who were accustomed to wearing her clothes.

**Perfumes and accessories.** In 1954 Chanel introduced a man’s fragrance, *Pour Monsieur*. The same year Pierre and Paul Wertheimer, who already owned *Parfums Chanel*, bought her entire business, and it remained within the Wertheimer family as of the early 2000s.

In 1955 Chanel introduced quilted handbags with shoulder straps of leather plaited with gilt chains with flattened links, similar to those used to weight her jackets. The bags were offered in leather or jersey and were initially available in beige, navy, brown, and black, lined with red grosgrain or leather—Chanel chose a lighter color for the interior to help women find small items in their bags. Updated each season, Chanel’s distinctive handbags were still top sellers in the early 2000s.

### The 1960s

By 1960 fashions by Chanel were no longer at the forefront of style. She abhorred the miniskirt, believing that a woman’s knees were always best concealed. But nonetheless she continued to clothe a faithful clientele in suits that were subtly reworked each season. One of her most high-profile and stylish clients from this period was Jacqueline Kennedy.

A suit that Chanel herself wore during the mid-1960s (model 37750) was purchased by London’s Victoria and Albert Museum. It consists of a three-quarter-length jacket and a dress made of black worsted crepe that reaches just below the knee, accessorized with a black silk stockinette-brimmed hat. Pristine white collar and cuffs are integral to the jacket—some clients complained that these touches wore out long before the jacket itself. Neat, unadorned, monochrome, and entirely functional, the suit has echoes of a school uniform.



In 1962 Chanel was again invited to design for the cinema, this time to dress Romy Schneider in Luchino Visconti's film *Boccaccio '70* and Delphine Seyrig in Alain Resnais's film *Last Year at Marienbad*. In 1969 Chanel herself became the subject of a Broadway musical called *Coco*, written by Alan Jay Lerner. With Chanel's permission, the title role was played by Katharine Hepburn.

Chanel died on 10 January 1971 in the midst of preparing her spring–summer 1971 collection. Her personal clothing and jewelry was sold at auction in London in December 1978.

### Postscript

Following Chanel's death, Gaston Berthelot was appointed to design classic garments in the Chanel tradition between 1971 and 1973. The perfume No. 19, named after Chanel's birthday, was launched in 1970. From 1974 Jean Cazaubon and Yvonne Dudel designed the couture line; in 1978 a ready-to-wear range was designed by Philippe Guibourgé; and in 1980 Ramon Esparza joined the couture team. But it was not until 1983, when Karl Lagerfeld was appointed chief designer, that the House of Chanel once again made fashion headlines: it remains the ultimate in desirability for a clientele of all ages in the early 2000s.

Since his appointment, Lagerfeld has continued to reference the Chanel style, sometimes offering classic interpretations and at other times making witty and ironic statements. Ultimately, he has developed the label to make it relevant to the contemporary market. Like its founder, he draws on sportswear for inspiration: surfing and cycling outfits inspired his fall–winter 1990–1991 collection; training shoes bearing the distinctive interlocked CC logo were shown for fall–winter 1993–1994; nautical styles were shown for spring–summer 1994; and skiwear styles were featured in fall–winter 2003–2004. While Chanel looked to the utilitarian dress of the working man, Lagerfeld derives his ideas from contemporary social subcultures. He has presented fetishistic PVC jeans, lace-up bustiers, dog collars, and plastic raincoats (fall–winter 1991–1992); biker-style leather jackets, trousers, and boots (fall–winter 1992–1993 and fall–winter 2002–2003); B-Boy- and Ragga-inspired styles (spring–summer 1994); and a more eclectic “rock chic” (fall–winter 2003–2004). The tweed suit continues to be a mainstay of the collections, satisfying classic tastes with cardigan styles and the more adventurous younger clients with tweed bra tops and micro-miniskirts. The classic cardigan-style suit has also been offered in terry cloth, while denim jackets are trimmed with Chanel's favorite camellia flowers (both for spring–summer 1991). Costume jewelry is used in abundance, and the little black dress is still inextricably associated with the name of Chanel.

To ensure the survival of the refined craft skills of the couture industry, the House of Chanel purchased five artisan workshops in 2002: the top embroiderer François Lesage, the expert shoemaker Raymond Massaro, the

flamboyant milliner Maison Michel, the feather specialist André Lemarié, and the leading costume jeweler Desrués.

Chanel perfumes remain top sellers. Since the founder died, the company has launched Cristalle (1974), Coco (1984), No. 5 Eau de Parfum (1986), Allure (1996), Coco Mademoiselle (2001), and Chance (2002) for women and Antaeus pour Homme (1981), Egoïste (1990), Platinum Egoïste (1993), and Allure Homme (1999) for men.

See also **Costume Jewelry; Handbags and Purses; Lagerfeld, Karl; Little Black Dress; Paris Fashion; Perfume; Vreeland, Diana.**

### BIBLIOGRAPHY

Charles-Roux, Edmonde. *Chanel and Her World*. London: Weidenfeld and Nicolson, 1979. Extensively illustrated in black and white, a standard text covering Chanel's major design achievements as well as her private and social life.

———. *Chanel*. London: Collins Harvill, 1989.

de la Haye, Amy, and Shelley Tobin. *Chanel: The Couturière at Work*. London: V and A Publications, 1994. Detailed analysis of Chanel's designs and working practice. Extensively illustrated in color, including many museum garments in detail.

Madsen, Axel. *Coco Chanel: A Biography*. London: Bloomsbury, 1990. Comprehensive account of Chanel's life.

Morand, Paul. *L'allure de Chanel*. London: Herman, 1976. An insight into Chanel's life written by an author friend.

Mauriès, Patrick. *Jewellery by CHANEL*. London: Thames and Hudson, Inc., 1993.

Amy de la Haye

**CHEMISE DRESS** The term “chemise dress” has traditionally been used to describe a dress cut straight at the sides and left unfitted at the waist, in the manner of the undergarment known as a chemise. This term has most often been used to describe outer garments during transitional periods in fashion (most notably during the 1780s and the 1950s), in order to distinguish new, unfitted styles from the prevailing, fitted silhouette.

In the eighteenth century, the primary female undergarment was the chemise, or shift, a knee-length, loose-fitting garment of white linen with a straight or slightly triangular silhouette. The term chemise was first used to describe an outer garment in the 1780s, when Queen Marie Antoinette of France popularized a kind of informal, loose-fitting gown of sheer white cotton, resembling a chemise in both cut and material, which became known as the *chemise à la reine*. After chemise dresses, cut straight and gathered to a high waist with a sash or drawstring, became the dominant fashion, around 1800, there was no longer a need to describe their silhouette, and the term “chemise” reverted almost exclusively to its former meaning.



**Christian Dior chemise.** Beltless sack dresses such as this were introduced in 1957, immediately spawning great debate. While many praised their comfort, others complained because they concealed the feminine figure. © HULTONARCHIVE/GETTY IMAGES. REPRODUCED BY PERMISSION.

Dresses were next described as chemises around 1910, when loosely belted, columnar dresses recalling early-nineteenth-century styles became popular. (The chemise was still worn as lingerie, but by the 1920s, it evolved into a hip-length, tubular, camisole-like garment with narrow straps.) Though the straight, unbelted dresses of the 1920s were more like chemises than any previous dress style, and have since been called chemise dresses by historians, the term was only occasionally used at the time. After fashion returned to a more fitted silhouette in the 1930s, the chemise dress reappeared around 1940, this time in the form of a dress cut to fall straight from the shoulders, or gathered into a yoke, but always meant to be worn belted at the waist.

The most important decade of the twentieth century for the chemise dress, however, was the 1950s. Early in that decade, the Parisian couturiers Christian Dior and Cristóbal Balenciaga, along with other designers in Europe and the United States, began experimenting with

unfitted sheath and tunic dresses, and belted chemise dresses continued to be popular. The major change, however, came in 1957, when both Dior and Balenciaga presented straight, unbelted chemise dresses that bypassed the waist entirely. Called chemises or sacks, these dresses were considered a revolutionary change of direction in fashion, and became the subject of heated debate in the American press; many commentators, particularly men, considered such figure-concealing styles ugly and unnatural, while proponents praised their ease and clean-lined, modern look. (The term “sack” may have been a reference to the eighteenth-century *sacque*, or sack-back gown, which Balenciaga revived in the form of chemises with back fullness, but it was also an apt description of the bag-like chemise silhouette.)

Waistless styles, both straight and A-line, continued to be controversial over the next several years, but they were gradually incorporated into most wardrobes, and became a staple of 1960s fashion. The term “chemise,” however, faded from use early in the 1960s, possibly because the press uproar of 1957 and 1958 had given it negative connotations (or because the lingerie chemise was a distant memory, having last been worn in the 1920s). Straight-cut dresses were now called shifts; more voluminous variants were the muumuu and tent dress. After another period of more fitted garments in the 1970s, unfitted dresses were again revived in the 1980s. Since then, however, women have had the option of choosing from a variety of silhouettes, and unfitted styles have simply been described as straight, or loose-fitting.

See also **A-Line Dress**; **Dior, Christian**.

#### BIBLIOGRAPHY

Keenan, Brigid. *Dior in Vogue*. London: Octopus Books, 1981.  
Miller, Lesley Ellis. *Cristóbal Balenciaga*. London: B. T. Batsford, Ltd., 1993.

“Topics of the Times.” *New York Times* (28 May 1958). Good contemporary overview and summary of the chemise controversy.

Susan Ward

**CHENILLE.** See **Yarns**.

**CHEONGSAM.** See **Qipao**.

**CHILDREN'S CLOTHING** All societies define childhood within certain parameters. From infancy to adolescence, there are societal expectations throughout the various stages of children's development concerning their capabilities and limitations, as well as how they should act and look. Clothing plays an integral role of the “look” of childhood in every era. An overview history of children's clothing provides insights into changes



**Nurse holding swaddled newborn in Mongolia.** Although not practiced in Western cultures since the eighteenth century, swaddling infants continues to be practiced in many South American, eastern European, and Asian cultures. © DEAN CONGER/CORBIS. REPRODUCED BY PERMISSION.

in child-rearing theory and practice, gender roles, the position of children in society, and similarities and differences between children's and adults' clothing.

Before the early-twentieth century, clothing worn by infants and young children shared a distinctive common feature—their clothing lacked sex distinction. The origins of this aspect of children's clothing stem from the sixteenth century, when European men and older boys began wearing doublets paired with breeches. Previously, both males and females of all ages (except for swaddled infants) had worn some type of gown, robe, or tunic. Once men began wearing bifurcated garments, however, male and female clothing became much more distinct. Breeches were reserved for men and older boys, while the members of society most subordinate to men—all females and the youngest boys—continued to wear skirted garments. To modern eyes, it may appear that when little boys of the past were attired in skirts or dresses, they were dressed “like girls,” but to their contemporaries, boys and girls were simply dressed alike in clothing appropriate for small children.

New theories put forth in the late seventeenth and the eighteenth centuries about children and childhood greatly influenced children's clothing. The custom of swaddling—immobilizing newborn infants with linen wrappings over their diapers and shirts—had been in place for centuries. A traditional belief underlying swaddling was that babies' limbs needed to be straightened

and supported or they would grow bent and misshapen. In the eighteenth century, medical concerns that swaddling weakened rather than strengthened children's limbs merged with new ideas about the nature of children and how they should be raised to gradually reduce the use of swaddling. For example, in philosopher John Locke's influential 1693 publication, *Some Thoughts Concerning Education*, he advocated abandoning swaddling altogether in favor of loose, lightweight clothing that allowed children freedom of movement. Over the next century, various authors expanded on Locke's theories and by 1800, most English and American parents no longer swaddled their children.

When swaddling was still customary in the early years of the eighteenth century, babies were taken out of swaddling at between two and four months and put into “slips,” long linen or cotton dresses with fitted bodices and full skirts that extended a foot or more beyond the children's feet; these long slip outfits were called “long clothes.” Once children began crawling and later walking, they wore “short clothes”—ankle-length skirts, called petticoats, paired with fitted, back-opening bodices that were frequently boned or stiffened. Girls wore this style until thirteen or fourteen, when they put on the front-opening gowns of adult women. Little boys wore petticoat outfits until they reached at least age four through seven, when they were “breeched” or considered mature enough to wear miniature versions of adult male clothing—coats, vests, and the exclusively male breeches. The age of breeching varied, depending on parental choice and the boy's maturity, which was defined as how masculine he appeared and acted. Breeching was an important rite of passage for young boys because it symbolized they were leaving childhood behind and beginning to take on male roles and responsibilities.

As the practice of swaddling declined, babies wore the long slip dresses from birth to about five months old. For crawling infants and toddlers, “frocks,” ankle-length versions of the slip dresses, replaced stiffened bodices and petticoats by the 1760s. The clothing worn by older children also became less constricting in the latter part of the eighteenth century. Until the 1770s, when little boys were breeched, they essentially went from the petticoats of childhood into the adult male clothing appropriate for their station in life. Although boys were still breeched by about six or seven during the 1770s, they now began to wear somewhat more relaxed versions of adult clothing—looser-cut coats and open-necked shirts with ruffled collars—until their early teen years. Also in the 1770s, instead of the more formal bodice and petticoat combinations, girls continued to wear frock-style dresses, usually accented with wide waist sashes, until they were old enough for adult clothing.

These modifications in children's clothing affected women's clothing—the fine muslin chemise dresses worn by fashionable women of the 1780s and 1790s look re-



markably similar to the frocks young children had been wearing since mid-century. However, the development of women's chemise dresses is more complex than the garments simply being adult versions of children's frocks. Beginning in the 1770s, there was general movement away from stiff brocades to softer silk and cotton fabrics in women's clothing, a trend that converged with a strong interest in the dress of classical antiquity in the 1780s and 1790s. Children's sheer white cotton frocks, accented with waist sashes giving a high-waisted look, provided a convenient model for women in the development of neo-classical fashions. By 1800, women, girls, and toddler boys all wore similarly styled, high-waisted dresses made up in lightweight silks and cottons.

A new type of transitional attire, specifically designed for small boys between the ages of three and seven, began to be worn about 1780. These outfits, called "skeleton suits" because they fit close to the body, consisted of ankle-length trousers buttoned onto a short jacket worn over a shirt with a wide collar edged in ruffles. Trousers, which came from lower class and military clothing, identified skeleton suits as male clothing, but at the same time set them apart from the suits with knee-length breeches worn by older boys and men. In the early 1800s, even after trousers had supplanted breeches as the fashionable choice, the jumpsuit-like skeleton suits, so unlike men's suits in style, still continued as distinctive dress for young boys. Babies in slips and toddlers in frocks, little boys in skeleton suits, and older boys who wore frilled collar shirts until their early teens, signaled a new attitude that extended childhood for boys, dividing it into the three distinct stages of infancy, boyhood, and youth.

In the nineteenth century, infants' clothing continued trends in place at the end of the previous century. Newborn layettes consisted of the ubiquitous long dresses (long clothes) and numerous undershirts, day and night caps, napkins (diapers), petticoats, nightgowns, socks, plus one or two outerwear cloaks. These garments were made by mothers or commissioned from seamstresses, with ready-made layettes available by the late 1800s. While it is possible to date nineteenth-century baby dresses based on subtle variations in cut and the type and placement of trims, the basic dresses changed little over the century. Baby dresses were generally made in white cotton because it was easily washed and bleached and were styled with fitted bodices or yokes and long full skirts. Because many dresses were also ornately trimmed with embroidery and lace, today such garments are often mistaken as special occasion attire. Most of these dresses, however, were everyday outfits—the standard baby "uniforms" of the time. When infants became more active at between four and eight months, they went into calf-length white dresses (short clothes). By mid-century, colorful prints gained popularity for older toddlers' dresses.

The ritual of little boys leaving off dresses for male clothing continued to be called "breeching" in the nineteenth century, although now trousers, not breeches,



**Brazilian men and boys in front of a church, 1942.** While children's clothing was once more distinct from that of adults, by the twentieth century children's dress more often mimicked that of their elders. © GENEVIEVE NAYLOR/CORBIS. REPRODUCED BY PERMISSION.

were the symbolic male garments. The main factors determining breeching age were the time during the century when a boy was born, plus parental preference and the boy's maturity. At the beginning of the 1800s, little boys went into their skeleton suits at about age three, wearing these outfits until they were six or seven. Tunic suits with knee-length tunic dresses over long trousers began to replace skeleton suits in the late 1820s, staying in fashion until the early 1860s. During this period, boys were not considered officially breeched until they wore trousers without the tunic overdresses at about age six or seven. Once breeched, boys dressed in cropped, waist-length jackets until their early teens, when they donned cutaway frock coats with knee-length tails, signifying they had finally achieved full adult sartorial status.

From the 1860s to the 1880s, boys from four to seven wore skirted outfits that were usually simpler than girls' styles with more subdued colors and trim or "masculine"



**Young girls in Brownie uniforms.** Children, in a mimicry of adults, wear uniforms for certain occasions. © HULTON-DEUTSCH COLLECTION/CORBIS. REPRODUCED BY PERMISSION.

details such as a vest. Knickerbockers or knickers, knee-length pants for boys aged seven to fourteen, were introduced about 1860. Over the next thirty years, boys were breeched into the popular knickers outfits at younger and younger ages. The knickers worn by the youngest boys from three to six were paired with short jackets over lace-collared blouses, belted tunics, or sailor tops. These outfits contrasted sharply to the versions worn by their older brothers, whose knickers suits had tailored wool jackets, stiff-collared shirts, and four-in-hand ties. From the 1870s to the 1940s, the major difference between men's and schoolboys' clothing was that men wore long trousers and boys, short ones. By the end of the 1890s, when the breeching age had dropped from a mid century high of six or seven to between two and three, the point at which boys began wearing long trousers was frequently seen as a more significant event than breeching.

Unlike boys, as nineteenth-century girls grew older their clothing did not undergo a dramatic transformation. Females wore skirted outfits throughout their lives from infancy to old age; however, the garments' cut and style details did change with age. The most basic difference between girls' and women's dresses was that the children's dresses were shorter, gradually lengthening to floor length by the mid-teen years. When neoclassical

styles were in fashion in the early years of the century, females of all ages and toddler boys wore similarly styled, high-waisted dresses with narrow columnar skirts. At this time, the shorter length of the children's dresses was the main factor distinguishing them from adult clothing.

From about 1830 and into the mid-1860s, when women wore fitted waist-length bodices and full skirts in various styles, most dresses worn by toddler boys and preadolescent girls were more similar to each other than to women's fashions. The characteristic "child's" dress of this period featured a wide off-the-shoulder neckline, short puffed or cap sleeves, an unfitted bodice that usually gathered into an inset waistband, and a full skirt that varied in length from slightly-below-knee length for toddlers to calf length for the oldest girls. Dresses of this design, made up in printed cottons or wool challis, were typical daywear for girls until they went into adult women's clothing in their mid-teens. Both girls and boys wore white cotton ankle-length trousers, called pantaloons or pantalets, under their dresses. In the 1820s, when pantalets were first introduced, girls wearing them provoked controversy because bifurcated garments of any style represented masculinity. Gradually pantalets became accepted for both girls and women as underwear, and as "private" female dress did not pose a threat to male power. For little boys, pantalets' status as feminine underwear meant that, even though pantalets were technically trousers, they were not viewed as comparable to the trousers boys put on when they were breeched.

Some mid-nineteenth-century children's dresses, especially best dresses for girls over ten, were reflective of women's styles with currently fashionable sleeve, bodice, and trim details. This trend accelerated in the late 1860s when bustle styles came into fashion. Children's dresses echoed women's clothing with additional back fullness, more elaborate trims, and a new cut that used princess seaming for shaping. At the height of the bustle's popularity in the 1870s and 1880s, dresses for girls between nine and fourteen had fitted bodices with skirts that draped over small bustles, differing only in length from women's garments. In the 1890s, simpler, tailored outfits with pleated skirts and sailor blouses or dresses with full skirts gathered onto yoked bodices signaled that clothing was becoming more practical for increasingly active schoolgirls.

New concepts of child rearing emphasizing children's developmental stages had a significant impact on young children's clothing beginning in the late-nineteenth century. Contemporary research supported crawling as an important step in children's growth, and one-piece rompers with full bloomer-like pants, called "creeping aprons," were devised in the 1890s as cover-ups for the short white dresses worn by crawling infants. Soon, active babies of both sexes were wearing rompers without the dresses underneath. Despite earlier controversy about females wearing pants, rompers were accepted without debate as playwear for toddler girls, becoming the first unisex pants outfits.

Baby books into the 1910s had space for mothers to note when their babies first wore “short clothes,” but this time-honored transition from long white dresses to short ones was quickly becoming a thing of the past. By the 1920s, infants wore short, white dresses from birth to about six months with long dresses relegated to ceremonial wear as christening gowns. New babies continued to wear short dresses into the 1950s, although by this time, boys only did so for the first few weeks of their lives.

As rompers styles for both day and night wear replaced dresses, they became the twentieth century’s “uniforms” for babies and young children. The first rompers were made up in solid colors and gingham checks, providing a lively contrast to traditional baby white. In the 1920s, whimsical floral and animal motifs began to appear on children’s clothing. At first these designs were unisex as the rompers they decorated, but gradually certain motifs were associated more with one sex or the other—for example, dogs and drums with boys and kittens and flowers with girls. Once such sex-typed motifs appeared on clothing, they designated even styles that were identical in cut as either a “boy’s” or a “girl’s” garment. Today, there is an abundance of children’s clothing on the market decorated with animals, flowers, sports paraphernalia, cartoon characters, or other icons of popular culture—most of these motifs have masculine or feminine connotations in our society and so do the garments on which they appear.

Colors used for children’s clothing also have gender symbolism—today, this is most universally represented by blue for infant boys and pink for girls. Yet it took many years for this color code to be come standardized. Pink and blue were associated with gender by the 1910s, and there were early efforts to codify the colors for one sex or the other, as illustrated by this 1916 statement from the trade publication *Infants’ and Children’s Wear Review*: “[T]he generally accepted rule is pink for the boy and blue for the girl.” As late as 1939, a *Parents Magazine* article rationalized that because pink was a pale shade of red, the color of the war god Mars, it was appropriate for boys, while blue’s association with Venus and the Madonna made it the color for girls. In practice, the colors were used interchangeably for both young boys’ and girls’ clothing until after World War II, when a combination of public opinion and manufacturer’s clout ordained pink for girls and blue for boys—a dictum that still holds true today.

Even with this mandate, however, blue continues to be permissible for girls’ clothing while pink is rejected for boys’ attire. The fact that girls can wear both pink (feminine) and blue (masculine) colors, while boys wear only blue, illustrates an important trend begun in the late 1800s: over time, garments, trims, or colors once worn by both young boys and girls, but traditionally associated with female clothing, have become unacceptable for boys’ clothing. As boys’ attire grew less “feminine” during the twentieth century, shedding trimmings and ornamental



**A baby layette set.** Parents in the late twentieth century could choose between gender-neutral and gender-specific clothing for their babies. Accents such as ribbons and flowers are designed for wear by a baby girl, whereas sports- or automobile-related graphics are designed for boys. TIME LIFE PICTURES/GETTY IMAGES. REPRODUCED BY PERMISSION.

details such as lace and ruffles, girls’ clothing grew ever more “masculine.” A paradoxical example of this progression occurred in the 1970s, when parents involved in “nonsexist” child-rearing pressed manufacturers for “gender-free” children’s clothes. Ironically, the resulting pants outfits were only gender-free in the sense that they used styles, colors, and trims currently acceptable for boys, eliminating any “feminine” decorations such as pink fabrics or ruffled trim.

Over the course of the twentieth century, those formerly male-only garments—trousers—became increasingly accepted attire for girls and women. As toddler girls outgrew their rompers in the 1920s, new play clothes for three- to five-year-olds, designed with full bloomer pants underneath short dresses, were the first outfits to extend the age at which girls could wear pants. By the 1940s, girls of all ages wore pants outfits at home and for casual public events, but they were still expected—if not required—to wear dresses and skirts for school, church,



parties, and even for shopping. About 1970, trousers' strong masculine connection had eroded to the point that school and office dress codes finally sanctioned trousers for girls and women. Today, girls can wear pants outfits in nearly every social situation. Many of these pant styles, such as blue jeans, are essentially unisex in design and cut, but many others are strongly sex-typed through decoration and color.

Adolescence has always been a time of challenge and separation for children and parents but, before the twentieth century, teenagers did not routinely express their independence through appearance. Instead, with the exception of a few eccentrics, adolescents accepted current fashion dictates and ultimately dressed like their parents. Since the early twentieth century, however, children have regularly conveyed teenage rebellion through dress and appearance, often with styles quite at odds with conventional dress. The jazz generation of the 1920s was the first to create a special youth culture, with each succeeding generation concocting its own unique crazes. But teenage vogues such as bobby sox in the 1940s or poodle skirts in the 1950s did not exert much influence on contemporary adult clothing and, as teens moved into adulthood, they left behind such fads. It was not until the 1960s, when the baby-boom generation entered adolescence that styles favored by teenagers, like miniskirts, colorful male shirts, or "hippie" jeans and T-shirts, usurped more conservative adult styles and became an important part of mainstream fashion. Since that time, youth culture has continued to have an important impact on fashion, with many styles blurring the lines between children's and adult clothing.

See also *Shoes, Children's; Teenage Fashions.*

#### BIBLIOGRAPHY

- Ashelford, Jane. *The Art of Dress: Clothes and Society, 1500–1914*. London: National Trust Enterprises Limited, 1996. General history of costume with a well-illustrated chapter on children's dress.
- Buck, Anne. *Clothes and the Child: A Handbook of Children's Dress in England, 1500–1900*. New York: Holmes and Meier, 1996. Comprehensive look at English children's clothing, although the organization of the material is somewhat confusing.
- Callahan, Colleen, and Jo B. Paoletti. *Is It a Girl or a Boy? Gender Identity and Children's Clothing*. Richmond, Va.: The Valentine Museum, 1999. Booklet published in conjunction with an exhibition of the same name.
- Calvert, Karin. *Children in the House: The Material Culture of Early Childhood, 1600–1900*. Boston: Northeastern University Press, 1992. Excellent overview of child-rearing theory and practice as they relate to the objects of childhood, including clothing, toys, and furniture.
- Rose, Clare. *Children's Clothes Since 1750*. New York: Drama Book Publishers, 1989. Overview of children's clothing to 1985 that is well illustrated with images of children and actual garments.

Colleen R. Callahan

**CHINA: HISTORY OF DRESS** Chinese clothing changed considerably over the course of some 5,000 years of history, from the Bronze Age into the twentieth century, but also maintained elements of long-term continuity during that span of time. The story of dress in China is a story of wrapped garments in silk, hemp, or cotton, and of superb technical skills in weaving, dyeing, embroidery, and other textile arts as applied to clothing. After the Chinese Revolution of 1911, new styles arose to replace traditions of clothing that seemed inappropriate to the modern era.

Throughout their history, the Chinese used textiles and clothing, along with other cultural markers (such as cuisine and the distinctive Chinese written language) to distinguish themselves from peoples on their frontiers whom they regarded as "uncivilized." The Chinese regarded silk, hemp, and (later) cotton as "civilized" fabrics; they strongly disliked woolen cloth, because it was associated with the woven or felted woolen clothing of animal-herding nomads of the northern steppes.

Essential to the clothed look of all adults was a proper hairdo—the hair grown long and put up in a bun or top-knot, or, for men during China's last imperial dynasty, worn in a braided queue—and some kind of hat or other headgear. The rite of passage of a boy to manhood was the "capping ceremony," described in early ritual texts. No respectable male adult would appear in public without some kind of head covering, whether a soft cloth cap for informal wear, or a stiff, black silk or horsehair hat with "wing" appendages for officials of the civil service. To appear "with hair unbound and with garments that wrap to the left," as Confucius put it, was to behave as an uncivilized person. Agricultural workers of both sexes have traditionally worn broad conical hats woven of bamboo, palm leaves, or other plant materials, in shapes and patterns that reflect local custom and, in some cases, ethnicity of minority populations.

The clothing of members of the elite was distinguished from that of commoners by cut and style as well as by fabric, but the basic garment for all classes and both sexes was a loosely cut robe with sleeves that varied from wide to narrow, worn with the left front panel lapped over the right panel, the whole garment fastened closed with a sash. Details of this garment changed greatly over time, but the basic idea endured. Upper-class men and women wore this garment in a long (ankle-length) version, often with wide, dangling sleeves; men's and women's garments were distinguished by details of cut and decoration. Sometimes a coat or jacket was worn over the robe itself. A variant for upper-class women was a shorter robe with tighter-fitting sleeves, worn over a skirt. Working-class men and women wore a shorter version of the robe—thigh-length or knee-length—with trousers or leggings, or a skirt; members of both sexes wore both skirts and trousers. In cold weather, people of all classes wore padded and quilted clothing of fabrics appropriate to their class. Silk floss—broken and tangled silk fibers

left over from processing silk cocoons—made a light-weight, warm padding material for such winter garments.

Men's clothing was often made in solid, dark colors, except for clothing worn at court, which was often brightly ornamented with woven, dyed, or embroidered patterns. Women's clothing was generally more colorful than men's. The well-known "dragon robes" of Chinese emperors and high officials were a relatively late development, confined to the last few centuries of imperial history. With the fall of the last imperial dynasty in 1911, new styles of clothing were adopted, as people struggled to find ways of dressing that would be both "Chinese" and "modern."

### Cloth and Clothing in Ancient China

The area that is now called "China" coalesced as a civilization from several centers of Neolithic culture, including among others Liaodong in the northeast; the North China Plain westward to the Wei River Valley; the foothills of Shandong in the east; the lower and middle reaches of the Yangtze River Valley; the Sichuan Basin; and several areas on the southeastern coast. These centers of Neolithic cultures almost certainly represent several distinct ethnolinguistic groups and can readily be differentiated on the basis of material culture. On the other hand, they were in contact with each other through trade, warfare, and other means, and over the long run all of them were subsumed into the political and cultural entity of China. Thus the term "ancient China" is a phrase of convenience that masks significant regional cultural variation. Nevertheless, some generalizations apply.

The domestication of silkworms, the production of silk fiber, and the weaving of silk cloth go back to at least the third millennium B.C.E. in northern China, and possibly even earlier in the Yangtze River Valley. Archaeological evidence for this survives tombs from that era; pottery objects sometimes preserve the imprint of silk cloth in damp clay, and in some cases layers of corrosion on bronze vessels show clear traces of the silk cloth in which the vessels had been wrapped. Silk was always the preferred fabric of China's elite from ancient times onward. As a proverbial phrase put it, the upper classes wore silk, the lower classes wore hempen cloth (though after about 1200 C.E. cotton became the principal cloth of the masses).

Depictions of clothed humans on bronze and pottery vessels contemporary with the Shang Dynasty (c. 1550–1046 B.C.E.) of the North China Plain show that men and women of the elite ranks of society wore long gowns of patterned cloth. Large bronze statues from the Sanxingdui Culture of Sichuan, dating to the late second millennium B.C.E., show what appears to be brocade or embroidery at the hemlines of the wearer's long gowns. Later depictions of commoners portray them in short jackets and trousers or loincloths for men, and jackets and skirts for women. Soldiers are shown in armored vests worn over long-sleeved jackets, with trousers and boots.



**Ceramic statuette of a woman in empire-line dress.** During the Tang Dynasty an empire-waisted dress tied below the bust-line and a short jacket became a popular ensemble. JOHN S. MAJOR. REPRODUCED BY PERMISSION.

Chinese silk textiles of the later first millennium B.C.E. (the Warring States Period, 481–221 B.C.E.) testify to the possibility of making very colorful and elaborately decorated clothing at the time. Surviving textiles also demonstrate the widespread appeal of Chinese silk in other parts of Asia. Examples of cloth woven in the Yangtze River Valley during the Warring States Period have been discovered in archaeological sites as far away as Turkestan and southern Siberia. Painted wooden figurines found in tombs from the state of Chu, in the Yangtze River Valley, depict men and women in long gowns of white silk patterned with swirling figural motifs in red, brown, blue, and other colors; the gowns are cut in such a way that the left panel wraps over the right one in a spiral that goes completely around the body. The gowns of the women are closed with broad sashes in contrasting colors, while the men wear narrower sashes. Bronze sash-hooks are common in tombs from the second half of the first millennium B.C.E., showing that the style of narrow waist sashes lasted for a long time. Elite burials also demonstrate a long-enduring custom of the wearing of jade necklaces and other jewelry.



**Chinese fashion magazine cover during the post-Mao period.** Fashionable clothing returned to China in 1978, and by the 1980s the fashion industry surged with a re-establishment of fashion magazines, shows, and classes. JOHN S. MAJOR. REPRODUCED BY PERMISSION.

### The Han Dynasty

Under the Qin (221–206 B.C.E.) and the Han (206 B.C.E.–7 C.E.; restored 25–220 C.E.), dynasties, China was unified under imperial rule for the first time, expanding to incorporate much of the territory within China's boundaries today. The famous underground terra-cotta army of the First Emperor of Qin gives vivid evidence of the clothing of soldiers and officers, again showing the basic theme of long gowns for elites, shorter jackets for commoners. One sees also that all of the soldiers are shown with elaborately dressed hair, worn with headgear ranging from simple head cloths to formal official caps. Cavalry warfare was of increasing significance in China during the Qin and Han periods; in funerary statuettes and murals, riders are often shown wearing long-sleeved, hip-length jackets and padded trousers.

The well-preserved tomb of the Lady of Dai at Mawangdui, near Changsha (Hunan Province, in south-central China) has yielded hundreds of silk dress items and textiles, from spiral-wrapped or right-side-fastening gowns, to mittens, socks, slippers, wrapped skirts, and

other garments, and bolts of uncut and unsewn silk. The textiles show a great range of dyed colors and weaving and decorating techniques, including tabby, twill, brocade, gauze, damask, and embroidery. Textual evidence from the Han period shows that government authorities attempted through sumptuary laws to restrict the use of such textiles to members of the elite landowning class, but that townsmen including merchants and artisans were finding ways to acquire and wear them also.

The period 220–589 C.E. (that is, from the fall of the Han to the rise of the Sui Dynasty), was one of disunity, when northern China was frequently ruled by dynasties of invaders from the northern frontier, while southern China remained under the control of a series of weak ethnically Chinese rulers. Depictions of dress from northern China thus show a predominance of styles suitable for horse-riding peoples. Elite men are sometimes shown wearing thigh-length wrapped jackets over skirts or voluminous skirtlike trousers. In southern China the traditions of colorful Yangtze River Valley silks predominated (though with a discernible trend toward plainer everyday clothing for elite men). Buddhism arrived in China via Central Asia during the late Han period, prompting the production of typical patchwork Buddhist monks' robes, as well as more formal embroidered or appliquéd ecclesiastical garments.

### The Tang Dynasty

Under the Sui (589–618) and Tang (618–907) dynasties, China was reunified and entered upon a period of unprecedented wealth and cultural brilliance. The capital city of Chang'an (now Xi'an) was, during the eighth century, the largest and most cosmopolitan city in the world. It supported a true fashion system, comparable to that of the modern West, in which rapidly-changing prevailing modes were adopted by fashion leaders and widely disseminated by emulation. Hairstyles (including the use of elaborate hairpins and other hair ornaments) and makeup also changed rapidly in fashion-driven patterns. Ceramic statuettes, produced in huge numbers during the Tang for placement in tombs, often depict people in contemporary dress, and thus give direct evidence for the rapid change of fashions at the time.

Under the Tang, trade along the Silk Route between China via Central Asia to the Mediterranean world flourished, and influence from Persian and Turkic culture areas had a strong impact on elite fashions in China. Chinese silk textiles of the Tang period show strong foreign influence, particularly in the use of roundel patterns. Young, upper-class women outraged conservative commentators by wearing "Turkish" hip-length, tight-sleeved jackets with trousers and boots; some women even played polo in such outfits. (Women more commonly went riding in long gowns, wearing wide-brimmed hats with veils to guard against sun and dust.) Another women's ensemble consisting of an empire-waisted dress tied just below the bustline with ribbons, and worn with





**Chinese beauty pageant.** The contestants wear *qipaos*, a colorful, tight-fitting garment, frequently slit up to the knee, which became the traditional dress of modern Chinese women by the mid-twentieth century. © CHINA PHOTO/REUTERS NEWMEDIA INC/CORBIS. REPRODUCED BY PERMISSION.

a very short, tight-sleeved jacket. This style would reappear several times in later ages, notably during the Ming Dynasty (1368–1644); it strongly influenced the development of the Korean national costume, the *hanbok*.

Dancers at court and in the entertainment districts of the capital and other cities were notable trendsetters. In the early eighth century, the fashionable ideal was for slender women wearing long gowns in soft fabrics that were cut with a pronounced décolletage and very wide sleeves, or a décolleté knee-length gown worn over a skirt; by mid century, the ideal had changed to favor distinctly plump women wearing empire-line gowns over which a shawl-like jacket in a contrasting color was worn. One remarkable later Tang fashion was for so-called “fairy dresses,” which had sleeves cut to trail far beyond the wearer’s hands, stiffened, wing-like appendages at the shoulders, long aprons trailing from the bustline almost to the floor, and triangular applied decorations on the

sleeves and down the sides of the skirt that would flutter with a dancer’s every movement. “Sleeve dancing” has remained an important part of Chinese performative dance since Tang times. Near the end of the Tang period, dancers also inspired a fashion for small (or small-looking) feet that led to the later Chinese practice of footbinding.

The Tang Dynasty was an aristocratic society in which military prowess and good horsemanship were admired as male accomplishments. Depictions of foot soldiers and cavalymen in scale armor and heavily padded jackets, and officers in elaborate breastplates and surcoats, are common in Tang sculptural and pictorial art.

#### **The Song and Yuan Dynasties**

In the Song Dynasty (960–1279), influenced by an increasingly conservative Confucian ideology and social changes that saw the gradual replacement of a basically

aristocratic society by one dominated by a class of scholar-gentry officeholders, clothing for both men and women at the elite level tended to become looser, more flowing, and more modest than the styles of the Tang. Women, who sometimes had bound feet, stayed home more, and sometimes wore broad hats and veils for excursions outside the home.

Portraits of emperors and high-court officials during the Song period show the first use of plain, round-necked robes worn either by themselves or as over-robes above more colorful clothing, and also the first appearance of the “dragon robes” embroidered with roundel figures of dragons as emblems of imperial authority.

The Yuan Dynasty (1279–1368) was the Chinese manifestation of the Mongol Empire conquered by Genghis Khan and ruled by his descendants. Mongol men in China, as well as men of Chinese ethnicity, wore loose robes similar to those of the Song period; horsemen wore shorter robes, trousers, and sturdy boots. Round, helmet-like hats were adopted for official use, replacing the earlier black horsehair or stiffened silk official cap. Women of the Yuan period sometimes wore two or more gowns at once, cut so as to show successive layers of cloth in harmonizing colors at the collars and sleeve-openings; Mongol women also wore high, elaborate headdresses like those of the Mongols’ traditional homeland.

### The Ming and Qing Dynasties

In Ming (1368–1644) times, both men and women wore voluminous clothing, a long robe with wide sleeves for men, a shorter robe worn over a wide skirt for women. In the early and middle Ming, there was a revival of the Tang style of empire-line dresses worn with short jackets, especially for young women. For much of its nearly three centuries of existence, the Ming was a time of prosperity and expanding production of goods of all kinds; there was a concomitant expansion of the type and variety of clothing available to all but the poorest members of society. Cotton, which had been introduced into China during the Song Dynasty, began to be raised extensively in several parts of the country. A short indigo-dyed cotton jacket worn over similar calf-length trousers (for men) or a skirt (for women) became and remained the characteristic dress of Chinese peasants and workers. Cotton batting substituted, in cheaper clothing, for silk floss in padded winter garments.

The dragon robe was adopted for standard court wear for emperors, members of the imperial clan, and high officials. The dragon robe evolved a standard vocabulary of motifs and symbols; typically such a robe was embroidered with large dragons, coiling in space and with the head shown frontally, on the chest and back; smaller dragon roundels on the shoulders and on the skirt of the robe; the space around the dragons embroidered with other auspicious symbols, and the bottom hem showing ocean waves and the peak of Mt. Kunlun, the mountain at the center of the world. The background color of the

robe indicated rank and lineage, with bright yellow limited to use by the emperor himself. Official court robes for women were similar but decorated with phoenixes (mythical birds depicted as similar to pheasants or peacocks), the feminine *yin* to the male *yang* of the dragon. (Hangings, banners, and other decorative items showing both a dragon and a phoenix are wedding emblems.)

Associated with the dragon robe and the codification of court attire was the use of so-called “Mandarin squares,” embroidered squares of cloth that were worn as badges of office for civil and military officials. These indicated rank in the official hierarchy by a set of sixteen animal or bird emblems—for example, a leopard for a military official of the third rank, a silver pheasant for a civil official of the fifth rank. These embroidered squares were made in pairs to be worn on the back and front of an official’s plain over-robe, the front square split vertically to accommodate the robe’s front-opening design.

The Qing Dynasty (1644–1911) brought new rulers to China—Manchus from the northeast, who overthrew the Ming Dynasty and preserved their hold on imperial power in part by being careful to preserve Manchu dress and other customs in order to keep the small population of conquerors from being submerged culturally by the much more numerous Chinese. The Manchus introduced new styles of clothing for official use; men were to wear short robes with trousers or wide skirts, cut more closely to the body than the flowing Ming styles, fastening at the right shoulder and with a high slit in front to accommodate horse-riding. A distinctive feature of the Manchu robe was its “horseshoe sleeves,” designed to cover and protect the back of a rider’s hands. Other Manchu styles were the “banner robe” (*qipao*), a straight-cut long robe worn by Manchu troops, and the “long gown” (*changshan*), a straight, ankle-length garment worn by Manchu women (who wore platform shoes on their unbound feet). Ethnic Chinese women wore loose-fitting jackets over wide skirts or trousers, often cut short enough to reveal the lavishly embroidered tiny shoes of their bound feet.

At court, the emperor, his kinsmen, and high officials wore dragon robes, the symbolic elements of which had been elaborately codified in the mid-eighteenth century; other officials wore plain robes with Mandarin squares. For all ranks, conical hats with narrow, upturned brims were worn for official occasions; buttons of precious or semiprecious stones at the hat’s peak also indicated the wearer’s rank.

Throughout China’s history, the country’s population has included many minority peoples whose language, dress, food, and other aspects of culture have been and remain quite different from those of the Han (Chinese) ethnic majority.

### Chinese Dress in the Twentieth Century

After the Nationalist Revolution of 1911, it was widely felt in China that, after a century of foreign intrusion and



**Chinese public official and family.** During the Ming Dynasty, embroidered “Mandarin Squares” began appearing on the robes of court officials (third man from right). These squares indicated the wearer’s rank in the government hierarchy. © HULTON-DEUTSCH COLLECTION/CORBIS. REPRODUCED BY PERMISSION.

national decline, the country needed to rid itself of old customs in order to compete with the other nations of the modern world. Thus began a search for new styles of clothing that were both “modern” and “Chinese.” The simple adoption of Western clothing was not a popular choice; foreign menswear was associated with Chinese employees of foreign companies, who were derided for being unpatriotic; fashionable Western women’s clothing struck many Chinese as both immodest and odd. Loose, baggy Western dresses introduced at some missionary schools in China were modest but unattractive.

Many men continued to wear a form of traditional clothing until the mid-twentieth century—a plain, blue, long gown for scholars and older, urban men, jacket and trousers of indigo-dyed cotton for workers. But among urban elites, there emerged in the 1910s a new outfit, based on Prussian military dress and seen first in China

in school and military-cadet uniforms; this had a fitted jacket fastened with buttons in front, decorated with four pockets, and made “Chinese” by the use of a stiff, high “Mandarin” collar, worn over matching trousers. This suit was often made, Western-style, in woolen cloth, the first time that wool had ever been the basis of an important Chinese garment type. This outfit became known as the Sun Yat-sen suit, after the father of the Chinese revolution.

Several proposals for creating a modern women’s dress for China met with little enthusiasm, but in China’s cities, and especially in Shanghai, women and their dress-makers were trying out a modern variation of Manchu dress that was to have lasting consequences. The Manchu “banner robe” (*qipao*) and “long gown” (*changshan*, generally known in the West by its Cantonese pronunciation, *cheongsam*) were adapted by fashionable women to



be somewhat more tightly fitting, with a closure folded left-over-right to the shoulder, then down the right seam, often fastened with decorative “frogs” (cloth buttons and loops), and sometimes with a slit to knee height. This new style, in colorful silk, rayon, or printed cotton, was widely publicized in “calendar girl” advertising prints of the 1920s and 1930s, and soon became firmly entrenched as China’s appropriately modern women’s wear. The *qipao* (or *cheongsam*) continued to evolve to become more form fitting, and by the mid-twentieth century was widely accepted, both in China and the West, as China’s “traditional” women’s dress.

For a few years after the Communist revolution of 1949, older forms of dress, including the man’s long “scholar’s robe” and the women’s *qipao*, continued to be worn in China. But by the late 1950s, there was strong political and social pressure for people to dress in “modest, revolutionary” styles—the Sun Yat-sen suit (usually in blue cotton, now beginning to be known as a “Mao suit”), or as an alternative, a modest blouse and calf-length skirt. By the time of the Cultural Revolution (1966–1976), the *qipao* had been denounced as “feudal,” and the wearing of the blue Mao suit was nearly obligatory.

Fashion made a cautious return to China in 1978, with the promulgation of the post-Mao “Four Modernizations” program of economic reform. By the early 1980s, fashion magazines had resumed publication, fashion shows were held in major cities, and fashion design and related subjects were beginning to be taught once again at the high school and college level. The *qipao* also has had a revival, both in China and in overseas Chinese communities, as formal wear that conveys a sense of ethnic pride, and as “traditional” dress worn by women in the hospitality industry. But in general, Chinese dress today is a reflection of global fashion. By the turn of the twenty-first century, prestigious international brands were a common sight in the shopping districts of Shanghai, Guangzhou, Beijing, and other major cities, and Chinese consumers were participating fully in international fashion. Meanwhile China had become the world’s largest manufacturer and exporter of garments.

See also **Asia, East History of Dress; Footbinding; Mao Suit; Qipao; Silk.**

#### BIBLIOGRAPHY

- Cammann, Schuyler, R. *China’s Dragon Robes*. New York: Ronald Press Company, 1952.
- Finnane, Antonia. “What Should Chinese Women Wear? A National Problem.” *Modern China* 22, no. 2 (1996): 99–131.
- , and Anne McLaren, eds. *Dress, Sex and Text in Chinese Culture*. Melbourne: Monash Asia Institute, 1998.
- Garrett, Valery M. *Chinese Clothing: An Illustrated Guide*. Hong Kong: Oxford University Press, 1994.
- Ng Chun Bong, et al., eds. *Chinese Woman and Modernity: Calendar Posters of the 1910s–1930s*. Hong Kong: Commercial Press, 1995.

Roberts, Claire, ed. *Evolution and Revolution: Chinese Dress, 1700s–1990s*. Sydney: The Powerhouse Museum, 1997.

Scott, A. C. *Chinese Costume in Transition*. Singapore: Donald Moore, 1958.

Steele, Valerie, and John S. Major. *China Chic: East Meets West*. New Haven and London: Yale University Press, 1999.

Szeto, Naomi Yin-yin. *Dress in Hong Kong: A Century of Change and Customs*. Hong Kong: Museum of History, 1992.

Vollmer, John E. *In the Presence of the Dragon Throne: Ch’ing Dynasty Costume (1644–1911) in the Royal Ontario Museum*. Toronto: Royal Ontario Museum, 1977.

Wilson, Verity. *Chinese Dress*. London: Bamboo Publishing Ltd. in association with the Victoria and Albert Museum, 1986.

Zhou Xun and Gao Chunming. *5000 Years of Chinese Costumes*. San Francisco: China Books and Periodicals, 1987.

John S. Major

**CHINOS.** See **Trousers.**

**CHINTZ** Originally, chintz was a brilliantly colored cotton calico from India. In the early 2000s, chintz, or glazed chintz, describes a firm, medium to heavyweight, balanced plain weave, spun-yarn fabric converted from print cloth or sheeting and finished with friction calendering. Chintz is usually all cotton or a cotton/polyester blend. Single carded and combed yarns are used in sizes ranging from 28 to 42 and counts ranging from 64 to 80 warp (lengthwise) yarns per inch and 60 to 80 filling (crosswise) yarns per inch. Chintz has a smooth, shiny glazed face and a dull back. Fully glazed chintz is finished with a compound that stiffens the fabric. A padding machine applies the finishing solution, then the fabric is partially dried, and friction calendered. One roll of the friction calender rotates faster than the other and polishes or glazes the fabric surface. If the solution is starch or wax, the effect is temporary. If the solution is resin based, the effect is permanent. Semi-glazed or half-glazed chintz has no stiffening agent and is friction calendered only. Similar fabrics are cretonne (not glazed) and polished cotton (glazed).

Chintz is usually printed in large, bright, colorful floral patterns. Sometimes it is dyed a solid color or printed with geometric patterns such as dots and stripes. It is made with fine, medium-twist warp yarns and slightly larger, lower-twist filling yarns. Chintz is used in draperies, curtains, slipcovers, and lightweight upholstery fabrics. Upholstery chintz usually has a soil- and stain-resistant finish. Chintz is sometimes used in women’s dresses, skirts, and blouses, and children’s wear. Permanently finished chintz can be machine washed and dried. Otherwise, dry cleaning is necessary to preserve the surface glaze. Chintz is a smooth, crisp fabric that drapes into stiff folds. The glaze may grow dull with use.



### GLOSSARY OF TECHNICAL TERMS

**Filling yarn:** Crosswise yarn in a woven fabric.

**Friction calendering:** Passing woven fabric between heated rollers that oscillate. After this treatment fabric has an increased shine, which will be permanent only if either the fibers or a finishing material applied to the fabric and thermoplastic.

**Warp yarns:** Lengthwise yarns in a woven fabric.

**Weft yarns:** Crosswise yarns in a woven fabric.

### History

The word “chintz” is from the Hindustani *chhint* or *chint*, derived from the Sanskrit *chitra* for spotted or bright. *Chints* was the original plural spelling of *chint*.

In the seventeenth century, plain weave cotton fabrics that had been hand-painted or block printed in India with brilliantly colored patterns of plants and animals were imported into Europe and America. The establishment of import/export companies in India by various European countries enhanced the trade of chintz as did the policy of sending sample patterns to India for craftsmen to copy. These novel fabrics were used for gowns, dresses, lounging jackets, robes, bed hangings and coverings, and household textiles. These fabrics quickly became popular because of their novel prints, texture, soft drape, and easy care. Because of their popularity, French craftsmen began to try to duplicate the patterns. This created competition problems for silk and wool goods produced by local weavers. Because of the potential loss of revenue and jobs, in 1686 the French government restricted production and importation of these fine quality, multicolored printed cotton fabrics (*Indiennes*) from India. England also restricted imports, even though India was an English possession.

In spite of various bans and prohibitions, the French, Dutch, Portuguese, and English imported chintz became the basis of European dress and furnishing designs throughout the rest of the seventeenth century and into the mid-eighteenth century. The imported fabrics combined indigo, madder, and an unknown yellow dye with a variety of mordants to achieve an amazing range of colors including blue, green, black, lilac, and crimson. The process of achieving this range of color with only a few natural dyes was not well understood in Europe at that time. The development of domestic printing facilities and the research needed to identify mordant and natural dye combinations and thickening agents for print pastes produced the European textile industry. Research

by English, German, and French dyers led to advances in dye chemistry and ultimately the development of synthetic dyes.

By the 1740s, demand for white goods from India increased as European printing houses were established. By the early 1750s, a drop in the quality of Indian printed goods had occurred, probably due to pressure for increased production and lower costs. By 1753, the Indian chintz export trade to Europe had virtually ceased. Efforts to minimize the costs and time needed to produce the fabric and the demand for more printed fabric with better performance led to the development of new mechanized printing methods.

The influence of Indian chintz has not disappeared. Some contemporary floral elements related to early Indian chintz patterns include the use of sprigs and bouquets, trailing floral patterns, and large realistic, brightly colored flowers.

### The Original Process

The cloth was flattened and burnished with buffalo milk and myrobolan (a dried fruit containing tannin) to give it a smooth surface. The protein in the milk probably provided bonding sites for the dyes. The pattern was drawn on paper. Holes were pierced through the paper along design lines. Powered charcoal was rubbed on the paper to transfer the pattern to the fabric. The design outlines were painted in. Then, the entire fabric surface was coated with wax except for those areas designed to be blue or green in the finished fabric. The fabric was immersed in an indigo vat, a requirement for fast blues and greens. After immersion in indigo, the dye was oxidized in the air and the fabric was dried. The fabric was scraped and washed to remove the wax. Most of the rest of the design was achieved by painting on a combination of mordants with thickening agents followed by dipping the fabric in a madder bath. Colors achieved in this manner include orange, brown, pink, crimson, lilac, purple, and black. Washing the fabric removed most of the madder in the non-mordanted areas. The fabric was aged in the sun to remove any residual color in the non-mordanted areas and to set the color in the mordanted areas. Finally, any areas requiring yellow (including any area dyed blue that was designed to be green in the finished fabric) were painted with saffron or another yellow dye. Unfortunately, since the yellow dye had poor light fastness, most historic chintz prints have lost that component of the design.

See also **Calico; Cotton; Dyeing.**

### BIBLIOGRAPHY

- Creekmore, Anna M., and Ila M. Pokornowski, eds. *Textile History Readings*. Washington, D.C.: University Press of America, 1982.
- Storey, Joyce. *The Thames and Hudson Manual of Textile Printing*. London: Thames and Hudson, Inc., 1992.

Tortora, Phyllis G., and Robert S. Merkel. *Fairchild's Dictionary of Textiles*. 7th ed. New York: Fairchild Publications, 1996.

Wilson, Kax. *A History of Textiles*. Boulder, Colo.: Westview Press, 1979.

Sara J. Kadolph

**CLARK, OSSIE** British designer Raymond (Ossie) Clark (1942–1996) was born on 9 June 1942 in Liverpool, England. He was known by his nickname Ossie, after Oswaldtwistle, the Lancashire village to which the family was evacuated during World War II. Clark started making clothes at the age of ten for his niece and nephew. Although he was not regarded as academically promising—he went to a secondary modern school where he learned building skills—he began to draw and developed a love of glamour and beauty, encouraged by his art teacher and mentor, who lent him copies of *Vogue* and *Harper's Bazaar*. For Clark, Diana Vreeland was always “top dog.”

### Early Career

Clark's copies of fashion pictures and ballet dancers showed skill. In 1958 he enrolled at the Regional College of Art in Manchester, where he was the only male student in the fashion course. The college emphasized technical training, so that Clark learned pattern cutting, construction, tailoring, and glove making—skills in which he excelled and which formed the basis of his distinctive style. In 1959 he saw a Pierre Cardin collection in Paris; he was struck by chiffon “peacock” dresses cut in what he described as a “spiral line,” which influenced his later work. In 1960 Clark became friends with Celia Birtwell, who was studying textile design at Salford College, and with the artist Mo McDermott, through whom he met David Hockney in 1961. Clark began a postgraduate course in fashion design at the Royal College of Art in London in 1962, under the aegis of Professor Janey Ironside.

The Royal College of Art produced not only such leading artists as Peter Blake and David Hockney, but also fashion designers who became well known in their own right: Janice Wainwright, Marian Foale, Sally Tuffin, Leslie Poole, Bill Gibb, Zandra Rhodes, and Anthony Price. Textile designer Bernard Nevill taught the students the history of fashion, taking them to the Victoria and Albert Museum, where they observed the collections, particularly those of clothing from the 1920s and 1930s. The students were introduced to the *Gazette du bon ton*, and Neville had them produce illustrations in the styles of George Barbier, Georges Lepape, and other artists of the period. Clark became an admirer of Madeleine Vionnet and Charles James; both designers influenced him, as did Adrian, who had designed the costumes for the film version of *The Women* (1939). “Bernard Nevill . . . opened all the students' eyes to the fact that fashion wasn't about rejecting what your parents stood for. . . . the glamour of

the thirties and the satin bias; we thought, why can't people on the street wear them?”

Clark graduated from the Royal College in 1965, the only student in his class to complete the course with distinction. He was photographed by David Bailey for *Vogue*, with the model Chrissie Shrimpton wearing his Robert Indiana op art-print dress. His degree collection was sold at the Woollands 21 boutique; he also began designing for Alice Pollock, part owner of the boutique Quorum in Kensington, close to Barbara Hulanicki's Biba and the Kings Road. Quorum quickly became part of “the most exciting city in the world,” as described by writer John Crosby in a 1965 article that discussed youth, talent, and sexual freedom in “swinging London.” The new post-Profumo society had a Labour government; unemployment was low, exports were high, and young working women were wearing Mary Quant's miniskirts. Clark and Pollock articulated the new freedom through their clothes. In 1966 Clark's Hoopla dress, a short shift cut to fit without darts and influenced by John Kloss, was featured in *Vogue*.

### Success

In 1967 Clark's Rocker jackets and culottes defined the look of “Chelsea Girls” like Patti Harrison, Anita Palenberg, Marianne Faithfull, Amanda Lear, and Jane Rainey, who was married to Michael Rainey, the proprietor of the Kings Road boutique Hung On You. All were friends for whom Clark made clothes. At this time Alice Pollock suggested to Celia Birtwell that she should design fabrics for Quorum, especially for Clark's styles. Birtwell's floral patterns were influenced in color and design by the work of the Russian artist Leon Bakst as well as by flowers, naturalistic early imagery from manuscripts, and the textiles from collections at the Victoria and Albert Museum, consisting of printed silk chiffon, marrocaïn crepes, and velvets. Birtwell's fabrics were discharge-printed at Ivo Printers, and used to create such dresses as “Acapulco Gold” or “Ouidjita Banana.” Clark cut chiffons and crepes on the straight and turned them to fit the body on the bias, to form the “spiral line” that he had seen at Cardin's show. He also experimented with alternatives to zippers, in particular ties or numerous covered buttons. His versatility in the period from 1967 to 1968 was best illustrated by his use of a range of materials as well as by the clothes themselves. Clark made use of snakeskin and leather as well as chiffon, satin, crepe, tweed, and furs. In 1967, the year in which the film *Bonnie and Clyde* was released and marked a return to nostalgia in fashion, Clark dropped his hemlines, shifting the focus to the wearer's bosom and shoulders, back, or waist to “find a new permutation and erogenous zones,” he said. In 1968 *Vogue* featured his tailored redingote in a new “maxi” length. At the end of the same year he launched his “Nude Look,” transparent chiffon dresses worn with little or no underwear. His couture pieces, made for such friends as Kari-Anne Jagger, had small hid-



den pockets, just big enough to hold a key and a five-pound note to pay the cab fare home. At the same time, a Clark menswear range was launched, which included ruffled shirts and printed chiffon scarves that were worn by the Rolling Stones, David Hockney, and Jimi Hendrix.

Both Quorum and the Ossie Clark name were sold to a middle-market company, Radley Gowns, in 1968. There were now three Clark lines: a couture line, Ossie Clark for Quorum, and Ossie Clark for Radley—which retailed at an accessible price not only at Quorum, which had relocated to the Kings Road, but also at other boutiques and department stores. In 1969 Clark and Birtwell were married when she became pregnant with their first child. Prudence Glyn, the fashion editor of *The Times*, chose a nude-look ruffled top and matching satin trousers made in Birtwell's trefoil print as the dress of the year for the Museum of Costume in Bath. "Ossie Clark is I believe in the world class for talent; in fact I think that we should build a completely modern idea of British high fashion around him," she wrote. Clark's contemporary Leslie Poole argued his importance at this point in his career: "He liberated women by constructing the low neckline with a bib front, tied at the back that could fit anybody. He borrowed lots of things like pointy sleeves and bias cut, but he effectively altered fashion through this new construction."

In 1970 Clark was invited to design a ready-to-wear collection by the French manufacturer Mendes, to be distributed in France and the United States. It was launched at the musée du Louvre on 22 April 1971 to high acclaim. Clark's collection featured top-quality chiffons, velvets, and silks, cut into frills and parachute pleats, 1940s-inspired panels and plunging necklines, floating shapes and tightly tailored wools. He produced one collection, for reasons still unclear, but continued to show and work in London, dressing Mick Jagger in jumpsuits based on anatomical drawings by Leonardo da Vinci, and making trouser suits for Bianca Jagger. David Hockney's portrait *Mr and Mrs Clark and Percy* (1970–1971) commemorated one of the most famous couples in fashionable London—and their pet cat.

### Last Years

Clark's early success did not last. In 1974 he separated from business partner Alice Pollock, and was divorced by Birtwell, who had grown tired of his affairs with men. In October 1974, Clark was the featured speaker at a fashion forum at the Institute of Contemporary Arts in London; he discussed marketing opportunities for the future on that occasion while admitting that he was living the lifestyle of a rock star. Unfortunately his work became disjointed by depression and alcohol abuse in the mid-1970s and appeared in magazines only intermittently. A relaunch in 1977 was not a success because Clark's clothes were not in touch with the London of Vivienne Westwood and punk style. Clark had little business sense, and declared bankruptcy in 1981. Shortly before his death however, he



**Ossie Clark ensemble.** Clark utilized numerous different materials in his designs and showed a preference for garments that were tied or buttoned, rather than zipped. © HULTON-DEUTSCH COLLECTION/CORBIS. REPRODUCED BY PERMISSION.

had started to make clothes again. Clark was stabbed to death in October 1996 by a former lover, Diego Cogliato. Designers working today influenced by Clark include Anna Sui, John Galliano, Christian Lacroix, Dries van Noten, Marc Jacobs and Clements Ribeiro.

See also **Adrian; Biba; Cardin, Pierre; Celebrities; Galliano, John; Lacroix, Christian; London Fashion; Rhodes, Zandra; Vreeland, Diana.**

### BIBLIOGRAPHY

- Clark, Ossie. Recording of Ossie Clark at the Institute of Contemporary Arts, 16 October 1974, possession of this writer and with thanks to Ted Polhemus, host of the event.
- . Recording of Ossie Clark lecture at the Royal College of Art, 1996, courtesy of Dr. Susannah Handley and the RCA.
- Green, Jonathon. *All Dressed Up: The Sixties and the Counterculture*. London: Jonathan Cape, 1998.
- Vogue* (British) August 1965.

Watson, Linda. *Ossie Clark*. Warrington, U.K.: Warrington Museum and Art Gallery, 2000.

Watt, Judith. *Ossie Clark 1965–1974*. London: Victoria and Albert Museum, 2003.

*Judith Watt*

**CLASS.** See **Social Class and Clothing**.

**CLEAN-ROOM SUITS.** See **Microfibers**.

**CLOSURES, HOOK-AND-LOOP** The hook-and-loop closure has been voted one of the best inventions of the twenty-first century by scientists. “Hooked” to numerous articles of our day-to-day life, hook-and-loop fasteners are used to secure footwear and clothing as well as to anchor equipment on NASA’s space shuttles and simplify storage and fastening solutions.

The hook-and-loop closure was conceived in 1948 by the Swiss mountaineer George de Mestral who loved two things—inventing and the great outdoors; he went on to become an engineer. Confident that Mother Nature was the best engineer of all, George de Mestral was both intrigued and annoyed by the burrs that stuck to his wool hunting pants and his dog’s fur. Determined to rid himself of the annoying and tedious task of their removal from clothing and fur, George de Mestral examined the burrs under a microscope. He discovered that each burr consisted of hundreds of tiny hooks that grabbed into the threads of fabric and animal fur. Convinced that nature had created something that could simplify fastening solutions, he discussed his idea of a hook-and-loop fastener that could compete with the zipper with textile experts in Lyon, France.

The first hook-and-loop closure was initially produced on a small handloom. The potential for mass production was not realized until de Mestral accidentally discovered that by sewing nylon under an infrared light, loops which were virtually indestructible could be formed in the same interlocking fashion as his cotton system.

In 1951 George de Mestral applied for a patent for this hook-and-loop invention in Switzerland and received additional patents in Germany, Great Britain, Sweden, Italy, Holland, Belgium, France, Canada, and the United States. Thus, de Mestral’s company, Velcro S.A., was born.

#### **Key Manufacturers**

The name Velcro is derived from the French words “velour” (velvet), and “crochet” (hook). Although the patent expired in 1979, Velcro is a registered trademark of Velcro USA and the company is the largest manufacturer of apparel hook-and-loop fasteners. Over 251 trademark registrations are held in more than 100 countries. The 3M Company is its only significant competition in

adhesive-back hook-and-loop closures. The 3M Company focuses on adhesive backed products instead of sew on, and therefore is not geared to the apparel industry. Hook-and-loop closures are integral components of outerwear garments, active sportswear, knee and elbow pads, as well as sports helmets. The elderly and handicapped greatly benefit from its versatility. The children’s wear industry makes significant use of hook-and-loop closures in many aspects of apparel. Because of its child-friendly application, these closures are also used on a variety of notebooks, backpacks, and footwear.

The infant and newborn segment of the children’s wear market takes full advantage of the benefits of hook-and-loop closures as the fastener of choice on diapers. Nike, who began the use of the Velcro brand fastener on infant sneakers in the late 1970s, continues in the twenty-first century with a sneaker that can be placed on the baby’s foot with one hand. Children often wear shoes with Velcro brand fasteners before they learn to tie their shoes. Velcro brand products are manufactured in Canada, China, Mexico, Spain, and the United States.

See also **Children’s Clothing; Shoes, Children’s; Sport Shoes; Sportswear**.

#### **BIBLIOGRAPHY**

Tsuruoka, Doug. “Stick to the Fine Points.” *Investor’s Business Daily* (14 July 2003): A4.

*Joanne Arbuckle*

### **CLOTHING, COSTUME, AND DRESS**

Clothing, costume, and dress indicate what people wear, along with related words like “apparel,” “attire,” “accessories” “garments,” “garb,” “outfits,” and “ensembles.” Many writers have tried to figure out why and when human beings began to decorate and cover their bodies; the reasons go beyond obvious considerations of temperature and climate, because some people dress skimpily in cold weather and others wear heavy garments in hot weather. Common reasons given are for protection, modesty, decoration, and display. One can only conjecture or speculate about origins, however, because no records exist detailing why early humans chose to dress their bodies.

Dress functions as a silent communication system that provides basic information about age, gender, marital status, occupation, religious affiliation, and ethnic background for everyday, special occasions and events, or participation in cinema, television, live theater, burlesque, circus, or dance productions. What people wear also can indicate personality characteristics and aesthetic preferences. People understand most clearly the significance and meaning of clothing, costume, and dress when the wearers and observers share the same cultural background. The words “clothing,” “costume,” and “dress” are sometimes used interchangeably to refer to what is being worn, but the words differ in several ways.

### Clothing

“Clothing” as a noun refers generally to articles of dress that cover the body. “Clothing” as a verb refers to the act of putting on garments. Examples of clothing around the world include articles for the torso such as caftans, wrappers, sarongs, shirts, trousers, dresses, blouses, and skirts, as well as accessories for the head, hands, and feet such as turbans, hats, gloves, mittens, sandals, clogs, and shoes.

### Costume

“Costume” as a noun describes garments of many types, particularly when worn as an ensemble. “Costume” as a verb often refers to designing an ensemble for an individual to wear. Frequently, “costume” refers to the clothing items, accessories, and makeup for actors, dancers, and people dressing up for special events such as Halloween, masquerade balls, Carnival, and Mardi Gras. A useful distinction between clothing and costume results when clothing refers to specific garments and costume refers to the ensemble that allows individuals to perform in dance, theater, or a masquerade, hiding or temporarily canceling an individual’s everyday identity.

The words “costume” and “custom” are closely related, and the word “costume” can also refer to ensembles of clothing (folk costume) worn by members of an ethnic group for special occasions that serve as an affirmation of the group’s traditions and solidarity.

### Dress

As a noun, “dress” is used in several ways: to indicate a woman’s one-piece garment, to indicate a category of garments such as “holiday dress” or “military dress,” or as a general reference to an individual’s overall appearance or various identities. As a verb, “dress” indicates the process of using various items to cover, adorn, and modify the body. The act of dress involves all five senses and encompasses more than wearing clothes. Getting dressed includes arranging hair, applying scent, lotion, and cosmetics, as well as putting on clothing of various textures and colors and jewelry, such as necklaces, earrings, and jangling bracelets. Dress ordinarily communicates aspects of a person’s identity.

### Distinctions among Clothing, Costume, and Dress

Items of clothing are components utilized in both costume and dress and designate specific garments and other apparel items such as footwear, headwear, and accessories. Costume is an ensemble created to allow an individual to present a performance identity for the theater, cinema, or masquerade, or to assert an identity as a member of an ethnic group on special occasions or for special events. Dress is the totality of body alterations and additions that help an individual establish credibility of identity in everyday life. In the United States, the term “costume history” ordinarily indicates the chronological study of dress, but in the United Kingdom, the term “dress history” is most frequently used.



**Tutu and feathered headdress.** Margot Fonteyn struts en pointe her lavishly decorated ballerina tutu and feathered headdress as the lead in the 1956 production of *Firebird*. Feathers and ruffles contribute to the creation of the *Firebird* costume look. © HULTON-DEUTSCH COLLECTION/CORBIS. REPRODUCED BY PERMISSION.

### Requirements for Costume and Dress

**Costume.** Designers for theater, cinema, and dance carefully plan the array of costumes to represent and highlight various roles to be played; principal characters are set apart and highlighted by costume from the rest of the cast or dance troupe. Some costumes designed for single-time use also involve countless hours of fastidious design and construction for adults in high-visibility and prestige Halloween or Mardi Gras events. For example, members of organized groups such as the various Krewes (masking and parading clubs) celebrating a New Orleans Mardi Gras or the San Antonio debutantes selected to be the duchess or princesses in their special ball engage in advance planning and execute intricate costume designs. In contrast, some Halloween costumes for adults or children may be quickly, even carelessly, made and worn for a short evening of venturing out for “trick or treat” candy or a casual masquerade party.

Costumes for the theater, dance, Halloween, and Mardi Gras have special requirements in fit, color, and effect. Garments must allow the performer’s body to





**Man wearing African elephant mask.** With some more extreme costumes, such as this one made mostly from palm fronds, much of the body is covered from view. © CAROLYN NGOZI EICHER. REPRODUCED BY PERMISSION.

move easily and be well made. For example, costumes of professional actors and dancers often receive hard wear. Constant use or vigorous movement for dancers, circus clowns, and acrobats can put a strain on garments, thus requiring sturdy fabrics and specific construction considerations like seam reinforcement. When many viewers see costumes from afar, colors or other aspects of design may be exaggerated for effect. Some colors, therefore, may be more bold or brilliant than choices for everyday dress. Others may be drab. Such choices depend on the interpretation of the costume designer in planning the garb for each performer's individual role and for the interaction among the performers.

**Dress.** In contrast to costume, dress establishes individual identity within a cultural context, emphasizing common social characteristics: age and gender, marital status, and occupation. Much information about identity is communicated through sensory cues provided by dress without the observer asking questions. Most individuals, especially in urban settings, have a variety of identities that are connected to dress, such as occupation, leisure-time activities (sports), and religious affiliation.

**Costume, dress, and the body.** Costumes and dress can reveal or conceal the body. Costumes or dress reveals the

body by allowing bare skin to be displayed; for example, shoulders, arms, legs, and feet in the case of the classic ballerina tutu or a swimsuit. In such examples as an ice-skater's bodysuit or dancer's leotard, the costume may cover but closely conform to and reveal the body shape. Sometimes aspects of a costume are exaggerated for ridicule and irony, as in the giant shoes seen on circus clowns or the padded bosoms of drag queens. In variations of Carnival and Mardi Gras costume, the body, including the head and face, is completely covered and the body is not easily discernible. Among the Kalabari people in the Niger delta of Nigeria one masquerade costume representing an elephant is made of massive palm fronds that eclipse the dancer's body. A small, carved sculpture of an elephant nestles among them, barely visible.

See also **Fashion.**

#### BIBLIOGRAPHY

- Eicher, Joanne B. "Classification of Dress and Costume for African Dance." In *The Spirit's Dance in Africa*. Edited by E. Dagan. Montreal. Galerie Amrad African Art Publication, 1997.
- , and Mary E. Roach-Higgins. "Describing Dress: A System of Classifying and Defining." In *Dress and Gender: Making and Meaning in Cultural Context*. Edited by Ruth Barnes and Joanne B. Eicher. Oxford and Washington, D.C.: Berg Publishers, 1992–1993.
- Laver, James. *Costume in the Theatre*. London: George G. Harrap and Company, Ltd., 1964.

*Joanne B. Eicher*

**COAT** A very important item in any cold climate, a coat is an outerwear garment with sleeves and a center-front closure, and as such incorporates many variations of style and shape including the chesterfield, crombie, British warm, and loden. The garment is designed specifically to be worn outdoors to protect the wearer from the damp, cold, wind, and dust and is most commonly worn over the rest of the clothes, so is generally slightly longer and wider than normal pieces of the wardrobe. However, although designed with protection in mind, not all coats are waterproof. Coats that are used to provide the wearer with extra warmth may be cut from cashmere, tweed, or fur. Coats worn as protection from the rain or snow, such as the classic raincoat or cape, will be made from lighter materials like gabardine or cotton, since they might be used in warm or cold weather.

#### History

Although a man's wardrobe has always contained at least one piece of outerwear that can be worn as protection from the elements (such as a cloak, gambeson, gown, cote-hardie, or mantle), the overcoat has been a popular garment for both men and women since technical ad-

vances in the art of tailoring during the seventeenth century. The emphasis has been placed primarily on fit rather than on material and flamboyant style.

Many clothing styles throughout history either have filtered up from working dress or derive from garments worn by the military or for sporting activities. This was true of the functional long, loose coat worn by the military in the early seventeenth century for riding. Cut with two front panels and two at the back, cuffed sleeves and straight side seams to allow the wearer's sword to pass through, the coat had become fashionable among gentlemen by the last quarter of the century.

In much the same way, the frock—a loose overgarment worn by workingmen—was also given the tailor's treatment. Originally known as a justcoat, buttons were added, sleeves were shortened and trimmed with broad cuffs (which were matched to the color of the waistcoat), and it became known as a frock coat. By 1690, the frock coat was characterized by its collarless neck, narrow shoulders, and buttoned front. It also featured conspicuously large front pockets and an opening for a sword. By the 1730s it had become a fashionable piece of outerwear and would continue to be so, albeit with slightly altering shape, for many years to come.

### **Eighteenth Century to the Twentieth Century**

With the riding coat firmly established as a fashionable staple garment, another form of overcoat known as the greatcoat would also become a functional style that influenced mainstream fashion. Available in either single-breasted or double-breasted options, with cape collar and center vent cut into the back, the greatcoat was considered essential for riding. By the latter part of the century, the greatcoat would feature overlapping collars similar to those on the coat worn by coachmen. By the early nineteenth century, greatcoats had become fashionable all-weather garments, worn both in the cities and the countryside. At this time some greatcoats would be lined or trimmed in velvet, have metal buttons, and the main body of the coat would be made from wool.

Taking the more practical or functional types of coats and turning them into fashionable garments remained a design and manufacturing trend that continued throughout the nineteenth century and is still noticeable today. A bewildering number of long or short coats, single- or double-breasted, would continue to be produced. Some coats were skirted, some would have pockets hidden in the pleats or otherwise flap pockets positioned on the skirt itself. The better-known styles from the period, coats still worn, would include the paletot (which was a shorter version of the greatcoat), inverness, covert, and the chesterfield that derived from a version of the earlier frock coat.

By the late 1850s coats were beginning to be cut with raglan sleeves which gave the wearer greater ease of movement, particularly if the coat was worn for riding.

The raglan or a shorter version of a single-breasted chesterfield, known as a covert coat, became "à la mode" for the growing trend for outdoor pursuits such as shooting and even country walking.

The biggest area of growth in the manufacturing of coats at the end of the nineteenth century and the turn of the twentieth century was the development of the raincoat. Effective waterproofing methods had been discovered by Charles Macintosh in the 1820s.

Aside from the move toward the development of the raincoat, overcoats remained much the same until the development of the driving coat in the first decade of the twentieth century. Once again a fully functional garment, the driving coat, produced by wardrobe companies such as Lewis Leathers (who would go on to produce iconic leather jackets during the 1950s) was designed to protect wearers from dust and water while keeping them warm in their open-top vehicles. Driving coats were often made from leather with a fur lining and worn with gauntlets and goggles.

Overcoats designed primarily for use in World War I made the transition to civilian use soon afterward. The British warm, as it is called in the United Kingdom, was a melton, double-breasted coat with shoulder tabs. It was developed for officers in the trenches and remains a popular style in the early 2000s. This was also true of the water-repellent and breathable Burberry trench coat made from fine-twill cotton gabardine especially for trench warfare.

Coats changed very little during the interwar years. World War II again led to innovation, providing men's wear with the only classic coat to have a hood—the duffel coat. Worn principally by servicemen in the Royal Navy, and popularized by Field Marshal Montgomery, this style flooded the market when they were sold as surplus after the war.

### **Coats in the Twenty-first Century**

Few coat styles have changed since the 1950s. Some may be shortened or lengthened, cut tighter to the waist, or even cut from a different cloth, but no classic new styles have been developed. Although the overcoat is still an essential item in the male and female wardrobe, heated offices and cars, central heating in the home, and the development of more technical fabrications have made it of much less importance than ever before.

*See also* **Jacket; Outerwear; Raincoat.**

#### **BIBLIOGRAPHY**

- Amies, Hardy. *A, B, C of Men's Fashion*. London: Cahill and Company Ltd., 1964.
- Byrde, Penelope. *The Male Image: Men's Fashion in England 1300–1970*. London: B. T. Batsford, Ltd., 1979.
- Chenoune, Farid. *A History of Men's Fashion*. Paris: Flammarion, 1993.

## COCKTAIL DRESS

- De Marley, Diana. *Fashion for Men: An Illustrated History*. London: B. T. Batsford, Ltd., 1985.
- Keers, Paul. *A Gentleman's Wardrobe*. London: Weidenfeld and Nicolson, 1987.
- Roetzel, Bernhard. *Gentleman: A Timeless Fashion*. Cologne, Germany: Konemann, 1999.
- Schoeffler, O. E., and William Gale. *Esquire's Encyclopedia of 20th Century Fashions*. New York: McGraw-Hill, 1973.
- Wilkins, Christobel. *The Story of Occupational Costume*. Poole: Blandford Press, 1982.

Tom Greatrex

**COCKTAIL DRESS** During the 1920s, newfound concepts of individuality and a repudiation of the Edwardian matronly ideal of respectable womanhood gave rise to the new phenomenon of the “Drinking Woman,” who dared to enjoy cocktails in mixed company (Clark, p. 212). She emerged at private cocktail soirées and lounges, and the cocktail dress, as a short evening sheath with matching hat, shoes, and gloves was designated to accompany her. The cocktail affair generally took place between six and eight P.M., yet by manipulating one’s accessories, the cocktail ensemble could be converted to appropriate dress for every event from three o’clock until late in the evening. Cocktail garb, by virtue of its flexibility and functionality, became the 1920s uniform for the progressive fashionable elite.

### Birth of the Cocktail Ensemble

By the end of World War I, the French couture depended rather heavily on American clientele and to an even greater extent on American department stores that copied and promoted the French *créateurs* (Steele, p. 253). As cocktailing had originated in the United States, the French paid less attention to the strict designations of line, cut, and length that American periodicals promoted for their *heure de l’aperitif*. Instead, the couturières Chanel and Vionnet created garments for the late afternoon, or “after five,” including beach pajamas—silk top and palazzo pant outfits worn with a mid-calf-length wrap jacket. Louise Boulanger produced *les robes du studio*, chic but rather informal sheaths that suited the hostess of private or intimate cocktail gatherings.

As the popularity of travel grew, both in American resort cities like Palm Beach, “the Millionaire’s Playground,” and abroad with the luxury of the Riviera, these French cocktail garments gained favor in wealthy American circles. But while America’s elite were promoting the exclusive designs of the French couture, the majority of the United States relied on the advertisements of *Vanity Fair* and American *Vogue*, as well as their patronage of American department stores to dress for the cocktail hour. Created by Chanel in 1926, the little black dress was translated to ready-to-wear as a staple of late afternoon and cocktail hours; American women at every level

of consumption knew the importance of a practical “Well-mannered Black” (*Vogue*, 1 May 1943, p. 75).

Mid-1920s skirt lengths were just below the knee for all hours and affairs. Though cocktail attire featured the longer sleeves, modest necklines, and sparse ornamentation of daytime clothing, it became distinguished by executions in evening silk failles or satins, rather than wool crepes or gabardines. Often the only difference between a day dress and a cocktail outfit was a fabric *noir* and a stylish cocktail hat. Hats in the 1920s varied little from the cloche shape, but cocktail and evening models were adorned with plumes, rhinestones, and beaded embroideries that indicated a more formal aesthetic. Short gloves were worn universally for cocktail attire during this period and could be found in many colors, though white and black were the most popular.

### From Day to Evening

In the early 1930s, Hollywood sirens like Greta Garbo embodied a casual, sporty American chic that paired easily with the separates ensembles favored by the French. The more privatized cocktail party of the silver screen began to gain popularity, replacing the smoking rooms of Paris and the dance clubs of New York. The stock market crash of 1929 and the resulting economic depression dictated that it was no longer fashionable to display wealth by throwing ostentatious public affairs. Exclusive lounges emerged rapidly on the Paris scene; Bergère, the Blue Room, and Florence’s were as popular for after-dinner cocktails as for the private affairs of the early evening. *Dames du Vogue* like Vicomtesse Marie-Laure de Noailles and Mrs. Reginald (Daisy) Fellowes, members of the elite international café society, became notorious for their exclusive soirées. Their patronage of Chanel, Patou, and Elsa Schiaparelli, all made famous by separates designs, helped popularize day-into-evening wear for upper-class Parisians and American socialites.

While Mademoiselle Cheruit had her *smoking*, a fitted jacket ensemble for early evening affairs, Schiaparelli was the most famous purveyor of the cocktail-appropriate dinner suit. Her suit consisted of a bolero or flared jacket that could be removed for the evening, revealing a sleeveless sheath dress. Unlike the previous decade, the 1930s dictated different skirt lengths for different hours: the silk, rayon, or wool crepe sheath of the dinner suit was steadfastly ankle or cocktail length.

In light of the economic hardships of the early 1930s, American designers like Muriel King designed “day-into-evening” clothes by championing a simple, streamlined silhouette and emphasizing the importance of accessories. Cartwheel hats, made of straw or silk and decorated with velvet ribbons or feathers, and slouchy fedoras of black felt were equally acceptable for the cocktail hour. Gloves were a bit longer than in the previous decade, but were still mandatory for late afternoon and evening. Costume jewelry, whether as a daytime pin or an evening parure,



became the definitive cocktail accessory. Excessive jewelry was promoted as both daring and luxurious when clothing itself was regulated to be modest and unfettered.

During World War II, the hemline of the cocktail dress rose again to just below the knee, but the convenience and accessibility of the fashionable cocktail accessory sustained. Parisian milliners like Simone Naudet (Claude Saint-Cyr) produced elegant chapeaus with black silk net veils for the cocktail hour. In New York, Norman Norell attached rhinestone buttons to vodka gray or billiard green day suits to designate them cocktail ensembles. By the mid-1940s, cocktailing was made easy by the adaptability of cocktail clothing and the availability of the indispensable cocktail accessory.

### A New Look for Cocktails

With his New Look collection of 1947, Christian Dior brought romanticism back to the catwalk. His cinched waists and full, mid-calf length frocks enforced a demure feminine aesthetic (Arnold, p. 102). The cocktail hour began to represent universal social identities for women: the matron, the wife, and the hostess. Cocktail parties rose to the height of sociability, and cocktail clothing was defined by strict rules of etiquette. While invitees were required to wear gloves, the hostess was forbidden the accessory. Guests were obligated to travel to an engagement in a cocktail hat (which had retained the veil made popular in the 1940s), but they were never to wear their hats indoors.

Parisian cocktail dresses were executed in black velvets and printed voiles alike, but they all retained the short-length of the original 1920s cocktail dress. American designers like Anne Fogarty and Ceil Chapman emulated the "New Look" line, but used less luxurious fabrics and trims. Dior, along with Jacques Fath and milliners Lilly Daché and John-Fredericks, quickly saw the advantages of promoting cocktail clothing in the American ready-to-wear market, designing specifically for their more inexpensive lines: Dior New York, Jacques Fath for Joseph Halpert, Dachettes, and John Fredericks Charmers.

Dior was the first to name the early evening frock a "cocktail" dress, and in doing so allowed periodicals, department stores, and rival Parisian and American designers to promote fashion with cocktail-specific terminology. *Vogue Paris* included articles entitled "Pour le Cocktail: L'Organdi," while advertisements in *Vogue* out of New York celebrated "cocktail cotton" textiles (*Vogue Paris*, April 1955, p. 77). Cocktail sets, martini-printed interiors fabrics, and cocktail advertisements all fostered an obsessively consumer-driven cocktail culture in America and, to some extent, abroad.

Though Pauline Trigère, Norman Norell, and countless Parisian couturiers continued to produce cocktail models well into the 1960s, the liberated lines of Gallitzine's palazzo pant ensembles and Emilio Pucci's



**Chanel cocktail dress.** In 1926, Coco Chanel originated the concept of the "little black dress," which, with the addition of certain accessories, could be worn for the evening cocktail hours. © CONDÉ NAST ARCHIVE/CORBIS. REPRODUCED BY PERMISSION.

jumpsuits easily replaced formal cocktail garb in privatized European and American social circuits. Often direct appropriations of midcentury designs, the cocktail dress and its partner accessories exist today on runways and in trendy boutiques as reminders of the etiquette and formality of 1950s cocktail fashions.

See also **Chanel, Gabrielle (Coco); Dior, Christian; Little Black Dress.**

### BIBLIOGRAPHY

- Arnold, Rebecca. *Fashion, Desire, and Anxiety: Image and Morality in the Twentieth Century*. New Brunswick, N.J.: Rutgers University Press, 2001.
- Clark, Norman H. *Deliver Us From Evil: An Interpretation of the American Prohibition*. New York: W. W. Norton and Company, 1976.
- "Dior's Convertible Costumes." *Vogue* (1 September 1951): 183a.
- Kirkham, Pat. *Women Designers in the USA 1900–2000*. New York: Yale University Press, 2000.
- "Les Décolleté de sept heures." *Vogue Paris* (September 1948): 141.
- "Les Pyjamas et les robes du studio." *Vogue Paris* (June 1930): 47.

## CODPIECE

Milbank, Caroline Rennolds. *New York Fashion: The Evolution of American Style*. New York: Harry N. Abrams, 1989.

Seeling, Charlotte. *Fashion: The Century of the Designer, 1900–1999*. Cologne, Germany: Konemann, 1999.

Steele, Valerie. *Paris Fashion: A Cultural History*. New York: Oxford University Press, 1988.

“The Well-Dressed Woman.” *Vanity Fair* (June 1928): 87.

*Elyssa Schram Da Cruz*

**CODPIECE** The codpiece was a distinguishing feature of men’s dress from 1408 to about 1575 C.E. Originally a triangle of cloth used to join the individual legs of men’s hose, the codpiece emerged as a nonverbal statement of political and economic power.

The codpiece began as a solution to changing fashion. Throughout the Renaissance, various forms of the doublet-and-hose combination characterized men’s dress. A doublet was a fitted, often quilted jacket that varied in length from above the knee to the natural waist. Hose were individually tailored legs of woven fabric cut on the bias grain. Each leg was stitched up the back and laced to the doublet, similar to the system of garter belts and stockings used by women in the middle twentieth century. An early version of underpants made of linen or



**Henry VIII in codpiece.** Often worn as a symbol of wealth or power, the codpiece had its heyday during the Renaissance period. © BETTMANN/CORBIS. REPRODUCED BY PERMISSION.

wool was worn underneath. As doublets shortened, hose were cut longer and wider to cover the underpants up to the waist. Across the genitals, a triangular gusset laced to the front of the hose between the legs. It satisfied decency requirements and calls of nature. By the sixteenth century, the codpiece was both shaped and padded. Squire and Baynes report that the term “cod” was both a Renaissance-era word for bag and a slang word for testicles. By the mid-1500s, the embellishment of the codpiece with jewels and embroidery exaggerated the genitals so that little was left to the imagination.

Once the codpiece achieved a pouch shape, it was used for a variety of purposes, including as a purse for small objects. When the fitted doublet/hose/codpiece combination is compared with the ankle-length, draped, and pleated robes of earlier periods, Renaissance men’s dress appears slim and ready for action. However, the bias cut of woven hose, while more elastic than straight grain, does not allow for a full range of movement. The successful application of knitting to create fine, well-fitting hose contributed to the decline of the codpiece by the turn of the seventeenth century.

Clear examples of the codpiece can be seen in sixteenth-century court portraits by Clouet, Titian, and Holbein. During this period, men’s dress extended the body into an overall horizontal silhouette. Codpiece, shoulders, and doublet were padded; luxury fabrics were slashed and their contrasting linings pulled out through the slits; and heavy gold chains were draped from shoulder to shoulder. Squire and Baynes describe the “aggressive solidity of appearance” and the “fantastic air of brutality” (1975, p. 66). Squire describes the fashionable man as, “broad-shouldered and barrel-chested, while a proudly displayed virility between his legs projected forcefully through the skirts of his jerkin” (1974, p. 52). In fact, the sixteenth century was a period of aggressive kingdom building in which more and more power was consolidated into the hands of fewer, very strong individuals. The codpiece contributed, in part, to the visible, and not at all subtle, expression of the power and the spirit of those times.

See also **Doublet; Penis Sheath.**

### BIBLIOGRAPHY

Boucher, François. *20,000 Years of Fashion: The History of Costume and Personal Adornment*. New York: Harry N. Abrams, 1987.

Squire, Geoffrey. *Dress and Society: 1560–1970*. New York: Viking, 1974.

Squire, Geoffrey, and Pauline Baynes. *The Observer’s Book of European Costume*. London: Frederick Warne and Company, Ltd., 1975.

Tortora, Phyllis, and Keith Eubank. *Survey of Historic Costume*. 3rd ed. New York: Fairchild Publications, 1998.

*Sandra Lee Evenson*

**COLONIALISM AND IMPERIALISM** The term “empire” covers a range of ways of incorporating and managing different populations under the rule of a single dominant state or polity, as for example in the Roman Empire, the Carolingian Empire, and the British Empire. A more detailed categorization might distinguish between colonialism as the ruling by an external power over subject populations and imperialism as intervention in or dominating influence over another polity without actually governing it. The two processes differ largely in terms of the extent to which they transform the institutions and organization of life in the societies subject to their intrusion; the transformations of colonialism tend to be more direct than those of imperialism.

Many European nations, the United States, China, and Japan have at one time or another exerted colonial rule over subject populations as part of regionally shifting geopolitical strategies combined with economic motives for gain. Although they applied diverse approaches to governing local societies, most colonial powers considered the people they ruled to be alien and different. Entering into the affairs of other societies, differentiating between groups and individuals in racial, ethnic, and gender terms, colonial rule reorganized local life, affecting colonized people’s access to land, property, and resources, authority structures and institutions, family life and marriage, among many others. These vast transformations of livelihoods had numerous cultural ramifications, including on dress.

Colonial powers have tended in recent centuries to be developed countries with strong agricultural and manufacturing economies and powerful urban centers. Their populations, and especially individuals directly involved in the colonial enterprise, have often regarded colonized indigenous peoples as “backward,” both culturally and socioeconomically. Appearance was a strongly contested area in the relations between colonizers and colonized. Indigenous people in many colonized societies adorned their bodies with cosmetics, tattooing, or scarification, wore feathers and other forms of ornament, and habitually went naked or dressed in animal skins or other non-woven materials. When they did wear woven cloth, it was often in the form of clothing that was draped, wrapped, or folded rather than cut, stitched, and shaped to the contours of the body. Dress and textiles conveyed information about gender and rank in terms different from those familiar to the colonizers. Such vastly different dress practices, especially nakedness, struck colonizers as evidence of the inferiority of subject populations. Because colonizers considered their own norms and lifestyles to be proof of their superior status, dress became an important boundary-marking mechanism.

### Clothing Encounters

The cultural norms that guided the West’s colonial encounters were shaped importantly by Christian notions of morality and translated into action across the colonial

world by missionary societies from numerous denominations. The colonial conquest by Spain and Portugal of today’s Latin America developed caste-like socioeconomic and political systems in which indigenous people and African slaves were forced to convert to Christianity and to wear Western styles of dress. Yet the rich weaving traditions of the Maya and Andean regions did not disappear but developed creative designs combining local and Christian symbols. When the Dutch colonized Indonesia in the seventeenth century and introduced Christianity, Islam was already long established. Subsequent interactions encompassed three distinct cultural spheres: Dutch and European, Muslim, and non-Muslim indigenous. The Dutch initially reserved Western-style dress for Europeans and for Christian converts.

Clothing “the natives” was a central focus of the missionary project in the early encounters between the West and the non-West, for example in Africa. In Bechuanaland, a frontier region between colonial Botswana and South Africa, the struggle for souls entailed dressing African bodies in European clothes to cover their nakedness and managing those bodies through new hygiene regimes. Missionaries were pleased when indigenous peoples accepted their clothing proposals, seeing it as a sign of religious conversion in the new moral economy of mind and body. In the Pacific, the encounter between missionary and indigenous clothing preferences sometimes produced striking results, as in the cultural synthesis in Samoan Christians’ bark cloth “ponchos” that not only expressed new ideas of modesty but also in fact made modesty possible by providing new ways to cover bodies. In a number of island societies, Pacific Islanders’ innovations and transformations of clothing resulted in new styles and designs.

In Melanesia, missionaries saw the eager adoption of printed calico as an outward sign of conversion, or at least openness to conversion, while Melanesians interpreted these patterns with reference to ideas about empowered bodies. Native peoples in North America also found floral designs on European printed cloth to be very attractive, incorporating them in embroidery on garments and crafts objects in increasingly stylized and abstract forms. Throughout the colonial world, missionary-inspired dress, often with links to traditional dress, developed in many directions. European styles and fabrics were incorporated in many places, such as in the smocked *Sotho* dress and the *Herero* long dress that serve as visible markers for “traditional” dress in southern Africa. Following independence from colonial rule, many such dress practices have come close to being considered national dress and are associated with notions of proper womanhood.

### Colonial Behavior

Western civilization set the standards of dress for colonizers in foreign outposts in a way that stereotyped the differences between colonizer and subject populations. For example, Westerners often made a point of dressing





**British soldiers in naval uniforms attack Malay villagers.** Indigenous peoples were often considered inferior by colonizers, in part because of their different dress practices, causing dress to become a status-defining mechanism. JOHN S. MAJOR. REPRODUCED BY PERMISSION.

in full European attire (woolen suits for men, corseted dresses for women) when touring up-country in the African bush or the jungles of Java; they wished their willingness to endure discomfort for the sake of dressing “properly” to be viewed as evidence of moral and cultural superiority. Although some Europeans in early encounter situations adopted local elements of dress, for example loose-stitched gowns of cotton and silk in India, colonial dress practice became increasingly rigid and formal. As time went by, colonial dress codes regarded cultural cross-dressing (a sign of “going native”) to be an affront to the standards of the ruling group. Obsessions over dress extended to climate and disease. The British in India and Africa wore special underwear to guard themselves against sudden weather changes. They wore *sola*

*topis*, flannel-lined solar helmets, to protect themselves against the dangerous rays of the sun. The fears associated with the physical environment provoked a form of a sometimes suicidal depression that contemporary medical doctors in east and southern Africa decried as tropical neurasthenia.

### Oppression and Resistance

In cases where colonial rulers regarded indigenous dress as a potential focus of resistance to the occupying power, suppression of local dress might be rigidly enforced. For example, when Korea was a Japanese colony (1910–1945), all markers of Korean cultural identity, including the use of the spoken and written Korean language and the wearing of the national *hanbok* costume, were ruthlessly sup-

pressed. In contrast, in the Japanese colony of Taiwan (ruled 1895–1945), there was no readily identifiable national dress, and so the Japanese authorities did not pay particular attention to what Taiwanese people wore.

Colonizers often could not fully control how subjected people dressed. Migrant labor, urban life, and education introduced new consumption practices and desires, among them factory-produced textiles and European-styled fashions. Local people sometimes wore the new garments as they saw fit. They were highly selective about which items of foreign dress they absorbed into their local dress repertoires. With new clothes also came new etiquettes that might be at variance with local ways, such as the practice in India and Indonesia of removing one's shoes when entering a building and covering one's head as signs of respect.

Indigenous persons of high rank, the new elite, and men were among the first to incorporate items of Western clothing into their wardrobes. Because the suit was a hallmark of colonial authority, jackets and trousers signified status, education, and colonial employment. In India, some men who adopted Western fabrics retained Indian dress styles while others had Indian garments tailored to take on a European look. New combination garments consisted of both Indian and European clothes—for example, shoes and trousers worn with coats in local styles and distinctive hats, a Western-style jacket on top of locally styled trousers or a sarong. In parts of Africa, highly decorated military uniforms were worn by kings and paramount chiefs on special occasions in combination with other styles of dress and accessories such as animal skins. The big robes, *boubous*, worn by Muslim men in West Africa, were not widely abandoned in favor of Western suits and are today worn with pride as evidence of a different dress aesthetic than the strong linear form of the Western suit.

Except for the elite, women in many parts of the colonial world were more resistant to adopt the new dress styles. Adopting European fabrics while retaining regional styles was popular among Indian women, who might add new accessories such as shoes, petticoats, and jackets to their Indian dress. Their saris might incorporate the latest trends in color and design from Europe. European suit jackets, often acquired in the used-clothing trade, are combined with indigenous garments in hybrid styles of men's clothing from Africa to Afghanistan. Across most of Africa, women eagerly appropriated factory-produced cloth, much of it manufactured in Europe incorporating "African" designs, into their everyday dress style of wrapper and headtie, tailored and highly constructed dresses, alongside a variety of Western-style garments.

### Exoticizing Dress Practices

In early colonial encounters, the British in India and the Dutch in Indonesia mapped and organized the diversity of the peoples they ruled in terms of dress. In late nineteenth- and early-twentieth-century Paris, Brussels, Lon-

don, and Chicago, among other places, preoccupations with the racial attributes of dress were showcased at expositions displaying colonial subjects in "traditional" clothes. The contemporary desire to catalog the world by parading exotic people in "traditional" dress as ethnographic specimens helped to accentuate the difference between the familiar and exotic in highly stereotypical ways. Postcards, produced for example in Algeria and Indonesia, displaying women in erotic stances and exotic clothing, made women's dress central to the marking of cultural difference. With the West as voyeur, such postcards projected invidious images of the exotic onto women's dressed bodies.

### Dress as Artifact and Cultural Revival

Not all segments of colonial society advocated the adoption of Western dress for their local subjects. Some, who were able to adopt an attitude of cultural pluralism, appreciated differences in dress without assuming the superiority of European styles, while others promoted the revival of local dress and adornment as a way of safeguarding threatened cultures and their aesthetics. In northeast Canada, French Ursuline nuns promoted pictorial and floral imagery among Native Americans in sewing and embroidery, stimulating a commodification of Indian curios. Over time, these depictions shifted from images of "noble savages" to colonial nostalgia scenes depicting the imminent disappearance of a way of life dependent on nature. Similar managed efforts in support of cultural survival were instituted in many places in Latin America, Africa, India, South and Southeast Asia, and the Pacific. Products of these cultural revival movements often did not remain within the societies that produced them, but were acquired for private and public collections and museums of textile arts. Although they all have given rise to interpretations about authenticity, such artifacts were everywhere the products of complex interactions and influences that demonstrate continuous incorporation of new developments and inspirations into "tradition."

The retention or revival of some of these clothing and textile traditions sometimes served to express rejection of colonialism, such as in Gandhi's call on Indians to wear homespun cloth. Some dress and textile traditions are used to make claims for political representation in states where indigenous people are subordinated or threatened, for example in the Amazon region of Brazil. Another development of the cultural revival of textiles and dress practices has turned the process into fashion, in which newly developed styles that are considered ethnically chic attract consumers in former colonies and the world beyond.

### The Seductions of Imperialism

Imperialism, which in the modern usage of the term usually involves influence on another country or culture but not direct colonial control, can have a powerful effect on the clothing of the subject culture. The effect is usually

voluntary (as opposed to the actual imposition of new forms of dress by missionaries and colonial administrators), but it can be seen as a form of cultural coercion in which voluntarism is compromised. The effects can take a wide range of forms.

In Japan during the Meiji Period (1868–1912), the government energetically promoted modernization as a way of strengthening the country, with a twofold goal: to prevent Japan’s being taken over as a colony by any European power, and to prepare Japan to compete on equal terms with Europe as a colonial power itself. The effort to emulate the strength of the West included a promotion of beef-eating (formerly nearly unknown in Japan) and a wholesale adoption of Western-style clothing, at least by urban elites.

In China at the end of the nineteenth century, a deliberate effort was made to design a new-style military and school uniform that would be “modern” but not too “Western.” The result was an early version of the Sun Yat-sen suit (later to be known in the West as the Mao Zedong suit), based on the Prussian military uniform but with a collar derived from that of the traditional Chinese long gown.

A third example, one so ubiquitous as to be part of the common wisdom about the modern world, has been the worldwide spread of sartorial markers of Western popular culture: the T-shirt, jeans, and running shoes. No one has forced any teenager in the Third World to wear these garments; almost no one (short of fanatical religious dictatorships such as the Taliban in Afghanistan) has succeeded in preventing them from doing so. Denounced by nationalists and cultural conservatives as “cultural imperialism,” the trend nevertheless seems irreversible.

**Transformative Encounters and Contesting Clothes**

Colonies and empires exerted a limited form of rule over subject populations both in relation to the exercise of power and the will and ability to transform society. The clothing practices colonialism inspired in many parts of the world demonstrate an important lesson about the relation between colonialism and dress. Colonialism was always a transformative encounter in which subject people were active participants rather than passive respondents to sartorial impositions from the outside. When dress served as a boundary-making mechanism, it did so in ways that were contested. Because the meanings of the dressed body everywhere are ambiguous, the colonial encounter enabled local people to take pride in long-held aesthetics expressed in new dress media and forms. It enabled the creation of styles of “national dress” that as invented traditions have served as cultural assertions for shifting claims to political voice and representation between the late colonial period and the present. Last but not least, colonial dress practices from Latin America, to India, to Japan have become part of everyday wardrobes everywhere, opening a world of dress for which everyone is the richer.

*See also* **Africa, North: History of Dress; Africa, Sub-Saharan: History of Dress; America, Central, and Mexico: History of Dress; America, North: History of Dress; Americas, South: History of Dress; Asia, East: History of Dress; Asia, South: History of Dress; Asia, Southeastern Islands and the Pacific: History of Dress; Asia, Southeastern Mainland: History of Dress.**

**BIBLIOGRAPHY**

Alloula, Malek. “The Colonial Harem.” In *Theory and History of Literatures*. Manchester University Press, 1986.

Colchester, Cloe, ed. *Clothing the Pacific*. Oxford: Berg, 2003.

Nordholt, Henk Schulte, ed. *Outward Appearances: Dressing State and Society in Indonesia*. Leiden, Netherlands: KITLV Press, 1997.

Phillips, Ruth B. *Trading Identities: The Souvenir in Native North American Art from the Northeast, 1700–1900*. Hong Kong: University of Washington Press, 1998.

Steele, Valerie, and John Major, eds. *China Chic: East Meets West*. New Haven, Conn.: Yale University Press, 1999.

Tarlo, Emma. *Clothing Matters: Dress and Identity in India*. London: Hurst and Company, 1996.

*Karen Tranberg Hansen*

**COLOR IN DRESS** Color attracts attention, creates an emotional connection, and leads the consumer to the product (Brannon, p. 117). Color is often a primary reason why a person is attracted to and buys a particular item of clothing. A new T-shirt in a different color can help transform the look of a product year after year. Color captures a viewer’s interest because it is both easily recognizable and distinctive. We often describe clothing in terms of color, such as “a blue suit.”

The study of color is complex and involves light, vision, and pigment as well as science, technology, and art. In addition, colored pigment behaves differently than colored light. Although there are many models of color classification, the Munsell color system with its numeric notation for each color is widely used and accepted to describe color pigments and the color properties that relate to dress.

**Color Dimensions**

All pigment color systems recognize that three dimensions describe color—hue (the name), intensity (brightness/dullness), and value (lightness/darkness). All three dimensions are present in every color and every color starts with hue. Value and intensity are adjectives that describe variations of any hue (light bright green, or deep dull red, for instance).

**Hue.** The name of the color as designated on the color wheel is its hue—the visual sensation of blue, for example. Each hue has an individual physical character: pri-





### COLOR FOR THE INDIVIDUAL

Packaging of colors for individual selection has been used to market color (Jackson 1981; Pinckney and Swenson 1981). Color selection for clothing is based upon colors that are grouped according to some easily remembered system, such as nature's seasons. Winter and spring colors are described as clear, vivid, and bright, while summer and fall are less intense. Winter and summer colors are cool; spring and fall colors are warm. Personal color analysis systems range from offering small pre-packaged color palettes, to specifically selected colors for each individual.

The Color Key system categorizes color according to warm or cool overtones that contain all basic hues, values, and intensities (Brannon 2000). Color Key 1 consists of cool, clear colors and Color Key 2 includes warm, earth tone colors; each has a corresponding color fan of paint chips that can be used to coordinate paint for interiors and apparel colors. This color key system implies that people will look and feel better when surrounded by colors that reflect their personal coloring.

mary pigment hues are red, yellow, and blue. No other colors combine to make them, but these colors combine to make all other hues. The secondary hues, orange, green, and violet are mixtures of the adjacent primary hues; orange is a mixture of red and yellow; violet is a mixture of red and blue. The hue spectrum runs from red to violet, and is usually depicted as a circle of hues with the primary hues separated by the secondary. Tertiary hues (sometimes called intermediate) result from mixing a primary and a secondary, that is, red-orange or blue-violet.

Groups or categories of colors that share common sensory effects are often called families. Related hues (sometimes called analogous) such as blue-violet, violet, and red-violet, are adjacent on the color wheel and constitute a color family. Contrasting colors are separated from each other on the color wheel. Contrasting color schemes include complementary and split-complementary. Hues opposite each other, such as yellow and purple-blue, are called complementary because they complete the spectrum; each contains primaries the other lacks. Complementary hues can produce an afterimage of each other. If you stare at one hue for several seconds, when you glance away to a neutral surface, you will see an image of its complement. In a split-complementary scheme

the color on either side of the complement is selected, green, red-orange, and red-violet, for example.

**Value.** Each hue has a specific normal or home value; the home value of yellow is close to white or light gray, and violet is as dark as very dark gray. Values have an effect upon colors in combination. For example, the complements red and green have similar values, offering hue contrast but not value contrast. However, the complementary hues of yellow and violet at normal value offer both hue and value contrast.

Contrasting values can affect the perception of edge in adjacent surfaces. A light value surface placed next to a dark one offers a strong visual pull to the difference between the two surfaces. Applications can be found in the value contrast between a white shirt and black trousers, light skin and dark hair, or dark hair and skin and pastel suit.

**Intensity.** The relative purity or saturation of a color is its intensity, sometimes referred to as chroma. This dimension describes the strength of a color. Saturated colors are primary and secondary hues at their purest and strongest on the color wheel. Each hue has a range of saturation from full intensity to neutral gray. Intensity provides hue with its vividness or neutrality. Intensity yields a variety of expressions. A saturated hue is intense and usually evokes a response of excitement or energy. Less saturated hues range from nearly bright to almost muted incorporating many moods. Hues in the lowest intensities are neutral colors and often are the foundation of a wardrobe. If used together at full strength, complementary colors can vibrate. The addition of a hue's complement lowers its saturation toward neutral gray and can increase its livability.

Intensity is influenced by surface texture. Even minor surface irregularities reflect minute areas of light that cast miniature shadows; this has the effect of dulling the intensity of a color. If a fabric with a distinct weave or surface were dipped into the same dye bath as a smooth material, it would appear duller in color because of the softening effect of the napped texture. Conversely, a smooth shiny surface will make a soft color appear stronger (Goldstein and Goldstein 1960, pp. 184–185).

#### Psychophysical Effects of Color

Psychophysical effects can be tied to hue characteristics. The temperature of a hue, the space from which it is viewed, and the color combinations used to create it can influence perception.

**Warm and cool.** Warm hues, light values, and strong intensities seem to advance while cool hues, dark values, and desaturated hues recede. Hues that advance also expand a shape. Warm colors and dark values are perceived as dense or solid and are often associated with muted earth tones such as brick or red-orange, ocher, or golden brown. Cool colors seem to reduce a shape. Cool hues

and light values are associated with air, distant mountains, and water and may present an appearance of distance, depth, shadow, coolness, and lightness.

Warm hues, light values, and saturated colors such as bright orange or shocking pink can seem loud or noisy. Cool hues, dark values, and desaturated colors like deep taupe or dark violet are quiet by comparison.

**Spatial position.** Hues viewed singly can produce an afterimage and this affects colors on the body. When the viewer concentrates on a clothing surface and then glances at the face, the skin can appear to take on tinges of the complement to the hue of the clothing. Thus after looking intensely at a green sweater, a viewer who glances up at the face may find it tinged with the complement, red.

Whether a hue is directly surrounded by another hue or is separated in some way will influence its perceptual effect. When individual colors are separated by black or white, both their singleness of character and their interaction are suppressed somewhat. Black causes adjacent hues to seem lighter and more brilliant; a surround of white often appears to darken them.

**Visual mixing.** Colors combined in very small patterns or woven together appear to mix visually. When two or more colors are interwoven onto one surface the result can be more vibrant than a surface of just one color. Complementary hues or black and white threads woven together will create a surface that appears gray or neutral when viewed from a distance. If the size of the black and white threads is increased, a salt-and-pepper effect is created.

### Color and the Body

Color and dress enter a relationship with color and the body. As a composite of colors, human coloration can be analyzed in the same way as other pigments to predict the effects of color in dress. Similarity of any of the attributes of colors placed upon the body can form a powerful visual relationship with the body.

A person's appearance is a combination of the surfaces placed upon the body and the individual's personal body coloring. Included in appearance are the body colors of skin, hair, and eyes. What surrounds a particular color affects how it appears. The pre-existing colors of the body are influenced by other colors placed upon it, so the body colors affect the surfaces placed upon it and the reverse is also true. In addition, the clothed body can be greatly influenced by colors of the surrounding environment and by lighting effects.

By matching, naming, and locating personal body colors, an individual can begin to understand color relationships. Intensity is a difficult dimension of color to describe when applied to body colors because the skin surface requires noting small and subtle differences. "Highlights" in one's personal coloring may include areas of the hair, skin, or eyes that seem more intense than

other areas. "Undertone" is used to describe underlying colors of skin and hair. Identifying both highlights and undertones for an individual helps in placing colors on the body that are related by similarity or contrast.

**Color as a source of association.** Color is associated with many natural objects of similar color and therefore can acquire similar meaning according to that association. Sunshine is yellow and warm: yellow is warm. Blue is cool and distant as the mountains and water. Red is exciting like fire and in many cultures red signals danger. Mood is associated with color, too; we have the "blues," or we are "green" with envy.

Colors may be associated symbolically with specific peoples or historic periods. In the 1960s in the United States, psychedelic colors were symbolic of the decade and included combinations of intense hues of pink, yellow, blue, green, and purple. Koreans favor celadon green, a pastel blue-green, because of its traditional association with pottery and ceramics, and white is used for mourning dress in Korea (Geum and DeLong).

**Color preferences.** Human response to colors can be measured and identified both collectively and individually, and psychologists have studied the formation of and reaction to color preferences. Eysenck (Brannon 2000) published research in 1941 that showed a consistent order of color preferences in adults: blue, red, green, purple, yellow, orange. According to Itten (1973) people have subjective individual preferences that include dimensions of hue, value, and intensity. The Lüscher Color Test (1969) links personality to color preferences. Subjects are asked to arrange color chips in order of preference and the results are analyzed to take into consideration both the meaning and impact of the colors as selected.

### Color Marketing

Color is rated as the most important aesthetic criterion in consumer preference (Eckman, Damhorst, and Kadolph 1990). Because color is a complex phenomenon, marketers can present merchandise in coordinated colors in an effort to help the consumer select purchases. When a line of clothing is color coordinated, wardrobe planning may seem less difficult to the consumer. Designers and manufacturers may coordinate colors within a season, or from one fashion season to another so that colors of a suit from the past season will coordinate with a shirt the next season. Selections of cosmetics are a part of color coordination of the body in a clothing ensemble and may be linked to personal coloring or to one's wardrobe colors.

**Fashion in colors.** Color has had a fashionable aspect historically. Editors of contemporary fashion often cite a color for a season as a means of marketing clothing. History is often recognized by the colors or color combinations fashionable at the time. Examples include the raspberry pink and lime green of mid-twentieth century,

or the pastels and filmy light tints at the end of the nineteenth century.

Forecasters take advantage of the importance attached to color by advancing a color palette for a given season. Color forecasting began in 1915 (Brannon 2000) and is based upon analysis of cultural demographics and color patterns. A cyclical pattern of color coordination occurs from High Chroma, Multicolored, Subdued, Earth Tones, Achromatic, Purple, and then back to High Chroma (Brannon 2000).

**Target markets.** Color is used for brand identification. Conceived broadly, this could include a designer's line of clothing or the introduction of a single color. Ralph Lauren tends to select middle value hues of low intensity for his depiction of "traditional" values. Elsa Schiaparelli introduced a single identifier, "shocking pink."

See also **Aesthetic Dress; Appearance; Dyeing.**

#### BIBLIOGRAPHY

- Arnheim, Rudolf. *Art and Visual Perception*. Berkeley and Los Angeles: University of California Press, 1974.
- Brannon, Evelyn. *Fashion Forecasting*. New York: Fairchild Publications, 2000.
- Davis, Marian. *Visual Design in Dress*. 2nd ed. Englewood Cliffs, N.J.: Prentice-Hall, Inc., 1987.
- DeLong, Marilyn Revell. *The Way We Look*. 2nd ed. New York: Fairchild Publications, 1998.
- Eckman, Molly, Mary Lynn Damhorst, and Sara Kadolph. "Toward a Model of the In-store Purchase Decision Process: Consumer Use of Criteria for Evaluating Women's Apparel." *Clothing and Textiles Research Journal* 8, 2 (1990): 13–22.
- Eiseman, Leatrice. *Alive With Color*. Washington, D.C.: Acropolis Books, Ltd., 1983.
- Geum, Keysook, and Marilyn DeLong. "Korean Traditional Dress as an Expression of Heritage." *Dress* 19 (1992): 57–68.
- Goldstein, Harriet, and Vetta Goldstein. *Art in Everyday Life*. 4th ed. New York: MacMillan, 1960.
- Itten, Johannes. *The Art of Color*. New York: Van Nostrand Reinhold Company, 1973.
- Jackson, Carole. *Color Me Beautiful*. New York: Ballantine Books, 1981.
- Luke, Joy Turner. *The Munsell® Color System: A Language for Color*. New York: Fairchild Publications, 1996.
- Lüscher, Max. *The Lüscher Color Test*. New York: Pocket Books, 1969.
- Mathis, Carla Mason, and Helen VillaConnor. *The Triumph of Individual Style: A Guide to Dressing Your Body, Your Beauty, Your Self*. Cali, Colombia: Timeless Editions, 1993.
- Meyers, Jack Fredrick. *The Language of Visual Art: Perception as a Basis for Design*. Chicago: Holt, Rinehart and Winston, Inc., 1989.
- Munsell, A. *A Book of Color: Neighboring Hues Edition, Matte Finish Collection*. Newburgh, N.Y.: Kollmmorgen, 1973.

Pinckney, Gerrie. *Your New Image Through Color and Line*. Costa Mesa, Calif.: Crown Summit Books, 1981.

Pooser, Doris. *Always in Style with Color Me Beautiful*. Washington, D.C.: Acropolis Books, Ltd., 1985.

Marilyn Revell DeLong

**COMME DES GARÇONS** Rei Kawakubo was born in Tokyo in 1942, the daughter of a senior academic at Keio University. She studied fine art (both Japanese and Western) at Keio and, after graduating in 1964, joined the advertising department of the Japanese chemical company Asahi Kasei, which produced acrylic fabrics. From 1967 she worked as a freelance fashion stylist, but, critical of the selection of clothes available in Japan, she started designing them herself.

I wanted to have some kind of job to earn money because at that time, having money meant being free. I never dreamt of being a fashion designer like other people. When I was young, it was just a way of earning a living by doing something I found I could do: making clothes and taking them around the shops to sell them. (Frankel, p. 8)

By 1969 she was producing clothing under the label Comme des Garçons, and in 1973 she formed a limited company. The moniker was typically enigmatic; named after the title of a French soldier's song meaning "Like the Boys," she designed clothes that eschewed conventional sexuality.

#### Distinctive Looks and Products

In 1975 Kawakubo showed her first collection in Tokyo, and in 1976, in a collaboration with the architect Takao Kawasaki, who has since designed most of Comme's typically calm and austere outlets, the first Comme des Garçons shop opened in the Minami-Aoyama district. The first shop did not even have mirrors, because Kawakubo wanted women to buy clothes because of how they felt rather than the way they looked. In 1978 Kawakubo introduced the Homme line; she followed it with Tricot and Robe de Chambre in 1981 and Noir in 1987. In 1981 Kawakubo launched her first women's collection in Paris at the same time as her compatriot Yohji Yamamoto, and soon afterward she joined the Chambre Syndicale du Pret-a-Porter.

Although the West was aware of other Japanese designers, such as Kenzo Takada and Issey Miyake, who had trained in Paris and New York, Kawakubo's vision was uncompromisingly severe and challenging. Her early shows made an indelible impression on the fashion world with their monochrome palette and distressed fabrics, with exposed seams and fraying edges influenced by Japanese work wear. Rather than echoing the contours of the body, she enclosed it in oversized swathes of fabric. The voluminous, layered, asymmetrical forms were accessorized with flat footwear, and the cosmetics and





**Woman models Comme des Garçons dress.** Japanese designer Rei Kawakubo's style is unconventional and cerebral, and she admits to favoring creations that are "difficult to wear." © CORBIS SYGMA. REPRODUCED BY PERMISSION.

hair styles seemed apocalyptic to many, but the influence of her clothes soon spread, particularly for those who were prepared to be challenged by clothing, "I think that pieces that are difficult to wear are very interesting, because if people make the effort and wear them, then they can feel a new form of energy and a certain strength. I want to give people that chance" (Petronio, pp. 154–155).

Early supporters included Joan Burstein, proprietress of Browns, who stocked Comme des Garçons beginning in 1981, and more recent enthusiasts from the art and media world include contemporary art gallery owner and collector Charles Saatchi, furniture designer Tom Dixon, chef Ruth Rogers, Lucy Ferry (rock-star Brian Ferry's wife), the actress Miranda Richardson, the rock star Sting, and Sting's wife, Trudi Styler. Kawakubo has explored color, and her silhouettes tend to be more fitted, but her work continues to be typified by complex patternmaking and experimentation with natural and man-made textiles. For those uncomfortable with overt sexuality in fashion and intrigued by her cerebral approach to material and form, Kawakubo's work offers an

alternative aesthetic language to mainstream Western fashion. Kawakubo's clothes are architectonic, concentrating on structure rather than surface. A black pullover with holes in it in the Victoria and Albert Museum's collection of 1982 is an essay on deconstruction of form and the contained chaos that it inhabits.

### Consistent Image

Kawakubo's aesthetic vision extends beyond clothes to embrace every facet of her company, giving consistency to her image all around the world. The controlled presentation of her clothes within the architecture of her shops includes photography, graphics, and packaging. She explains, "Everything that I do or that is seen as the result of Comme des Garçon's work is the same. They are all different ways of expressing the same shared values, from a collection to a museum, a shop or even a perfume" (Petronio, pp. 154–155). (Rather than having a name, each fragrance is simply numbered, based on its chemical components, and then vacuum packed like coffee in a plastic sachet.) Kawakubo's innovative graphics have been evident from early on in her career in a series of photographic catalogs of the collections and numerous brochures, posters, greetings, and announcement cards.

In 1988 she launched the biannual magazine *Six*, which is characterized by having little text, for Kawakubo prefers the images to speak for themselves. *Six* mixes images of clothes with portraits, photographic features, and shots of things that she finds beautiful, such as wildflowers growing beside a road or plastic sheeting flapping in the wind. This aesthetic was emulated in the photographic essay she designed for the exhibition catalog of the Victoria and Albert Museum's exhibition *Radical Fashion* (2001).

### Creative Collaborations

Kawakubo's creativity has extended to many events and collaborations, from museum and gallery exhibitions to performances to collaborations with architects, photographers, graphic designers, and even a floral artist. She has worked with the artists Cindy Sherman and Jean-Pierre Raynaud, and in 1997 she designed the set and costumes for Merce Cunningham's work *Scenario*, performed at the Brooklyn Academy of Music and the Palais Garnier in Paris. Kawakubo said that fashion and modern dance are

really the same. With a collection presentation, I think about the total concept, the environment, the lighting and the make-up as well as the clothes. And the pressure to create something new and beautiful is similarly the same. Of course, the added dimension is the dancers' movements which was the risk. When I saw the rehearsal for the first time, I was fascinated how the shapes changed and came alive with the movements of the dancers. (Johnson, p. 49)

The designs for *Scenario* derived from Kawakubo's spring 1997 collection, *Body Becomes Dress, Dress Be-*

comes Body, in which she used feather padding to produce bulges under the clothes, an effect that altered the natural silhouette of the body. Kawakubo said, "It is always stimulating to do new things. The goal of my work for 'Scenario' is the same as my goal for everything: to create something strong, and beautiful and new" (Johnson, pp. 48–53).

### Distinctive Collections

Although Kawakubo's clothes are typified by an independence from mainstream fashion, the collections often obliquely reflect current styles. For example, she included strips of camouflage (which was fashionable at the time) in her Optical Shock collection of 2001. Her autumn–winter 2002 collection parodied overtly provocative clothing with large, tulle, 1950s skirts and bras with squashed-in cups worn on top of jackets or even slung around the posterior, while the back seams of billowing trousers gaped open to reveal an arc of flesh. This was really modern erotica. She remarked,

What I would love to transmit and tell people isn't so much in my working method or creative approach, but more in the values in which I believe. It wouldn't be interesting if everyone wore the same clothes or worked the same ways. I would want to convince people to be courageous and try things differently. (Petronio, pp. 154–155)

Kawakubo's spring–summer 2004 collection featured skirt after skirt shaped like inverted flowers, teamed with a simple gauze top over bared breasts, radical because of its insistence on presenting only one form. The effect was to make the viewer focus on the variations on form and cloth, which varied from beige cotton to bright, bold patterns, completed with tricorne fabric headgear. Kawakubo described the collection as abstract excellence. Suzy Menkes described it as "an expression of artistry, imagination and a certain sweet elegance. And it represented the power of Paris to accommodate ideology in the industry."

### Overview of Company

In the early twenty-first century Comme des Garçons is an extremely successful company. Its various lines are designed to appeal to audiences in both the West and the East, all overseen by Kawakubo herself. In 1982 and 1983 she opened her first shops in Paris and New York, and in 1984 the Comme des Garçons Homme plus collection was introduced. In 1986 an American subsidiary company was launched, and in 1988 the shirt line, which was manufactured in France and provided affordable garments to a European audience, was introduced. In 1989 the Comme des Garçons flagship store opened in Aoyama, Tokyo. Having first designed furniture pieces specifically for her stores, Kawakubo turned her attention to a retail line of furniture in the late 1980s. In 1987 Comme des Garçons's furniture showrooms opened in Tokyo and Paris, with the furniture manufactured by the Italian

company Pallucco. In 1992 along with her protégé Junya Watanabe she launched the Junya Watanabe Comme des Garçons collection, and in 1993 the Comme des Garçons Comme des Garçons line was introduced. In 2000 a perfume boutique was opened in Paris.

### Recognitions and Legacy

Kawakubo has received many honors in recognition of her achievements. They include the following: Night of the Stars award from the Fashion Group, New York (1986); the Mainichi Newspaper award (1988); the Business Woman of the Year award from Veuve Clicquot (1991); and Chevalier de l'Ordre des arts et des lettres, awarded by the French Ministry of Culture (1993). In 1997 she received an honorary doctorate from the Royal College of Art, London, and in 2000, the Excellence in Design Award from the Harvard University Graduate School of Design, Cambridge, Massachusetts. Her work has also been celebrated in many museum and gallery exhibitions, such as *Mode et photo*, an exhibition of Comme des Garçons photography at the Centre Georges Pompidou, Paris (1986), and *Three Voices: Franco Albini, Kris Rubs, Rei Kawakubo*, Paris (1993). She has had a furniture exhibition at the Galleria Carla Sozzani, Milan, and the *Essence of Quality* exhibition of Comme des Garçons Noir with the Kyoto Costume Institute, Kyoto, Japan. In 1995 she participated in the *Mode and Art* exhibition in Brussels, Belgium. In 1996 she participated in the *Art and Fashion* exhibition at the Florence Biennale Internazionale dell'Arte Contemporanea in Italy. She featured in the *Three Women: Madeleine Vionnet, Claire McCardell and Rei Kawakubo* exhibition at the Fashion Institute of Technology, New York, and in *Radical Fashion* at the Victoria and Albert Museum in 2001.

Since Rei Kawakubo's first show in Paris, Comme des Garçons clothes have continued to be characterized by complex patternmaking and an unmistakable mix of the hand-crafted and technology. Her role in the history of twentieth- and twenty-first-century fashion is about the creative fusion of two cultures and two audiences. In her words, "If my ultimate goal was to achieve financial success, I would have done things differently, but I want to create something new. I want to suggest to people different aesthetics and values. I want to question their being" (Frankel, p. 158).

*See also Art and Fashion; Dance and Fashion; Fashion Designer; Fashion Magazines.*

### BIBLIOGRAPHY

- Fashion Institute of Technology. *Three Women: Madeleine Vionnet, Claire McCardell, and Rei Kawakubo*. New York: Fashion Institute of Technology, 1987. An exhibition catalog.
- Frankel, Susannah. *Visionaries: Interviews with Fashion Designers*. London: V&A Publications, 2001.
- . "Quiet Storm." *The Independent Magazine* (2002): 8.
- Grand, France. *Comme des Garçons*. London: Thames and Hudson, Inc., 1998.

- Johnson, Robert. "The Bulgies. Merce Cunningham's 'Scenario.'" In *Ballett International/Tanz Aktuell* (December 1997): 48–51.
- Petronio, Ezra. *Self Service* 13 (Autumn/Winter 2000): 154.
- Mendes, Valerie. *Black in Fashion*. London: V&A Publications, 1999.
- Menkes, Suzy. "Abstract Artistry from Kawakubo." *International Herald Tribune*, October 10, 2003.
- Sudjic, Deyan. *Rei Kawakubo and Comme des Garçons*. New York: Rizzoli International.

*Claire Wilcox*

**COMMUNIST DRESS** Communist dress appeared in diverse guises in Russia and East European countries during seventy-two years of communist rule, and both similarities and differences between them were informed by the political, economic, and social organization of society in the respective countries. The differences between those countries were twofold. The first group of differences is related to dogmatic implementation of communist orthodoxy, while the second refers to the fact that Soviet Russia turned to communism in 1917 and went through a series of very different communist practices, from Leninism through the NEP and its re-introduction of semicapitalism, to Stalinism, even before World War II. Soviet-style communism was imposed on other East European communist states, and after 1948 they were forced to reject their own fashion traditions and to officially accept the centralized Soviet model of clothes production and distribution. In that way, the periodization of communist dress codes from the 1950s onwards followed similar patterns in Soviet Russia and the East European countries. Still, practices of dress were diversified. Contrary to the prevailing image of communist dress as uniform and gray, three styles of clothing—official, everyday, and subversive—coexisted in communist societies, even though all communist regimes initially rejected the notion of fashion as decadent and bourgeois.

### **Bolshevik Rejection of Fashion**

In 1917, Bolshevik Russia attempted to abolish Western-style dress. The sartorial eclecticism that nevertheless prevailed in everyday life was heavily attacked, first by the futurists and later by the constructivists, as part of petit-bourgeois culture.

The constructivist artists Varvara Stepanova, Liubov Popova, Aleksandr Rodchenko, and Vladimir Tatlin all proposed simple, hygienic and functional clothes. In 1923, Stepanova's programmatic article, "The Dress of Our Times: The Overall," with its insistence on functionality, anonymity, simplicity, efficiency, and a precise social role for clothes, was the most radical proposal. In practice, only Popova and Stepanova entered into real production when, in 1923, they became textile designers in the First State Textile Print Factory in Moscow. They

abolished the traditional motives of flowers, but their minimalist geometric patterns never had a real chance compared with the old decorative florals, either inside the factory floor or among the traditionally oriented mass consumers.

### **Nadezhda Lamanova**

After seizing power, the Bolsheviks nationalized both textile factories and retail establishments, and their activities centralized. The most prominent pre-revolutionary Russian fashion designer, Nadezhda Lamanova, who catered for both the aristocracy and the artistic elite, and had been officially recognized as a couturier to the court, embraced the political and social changes brought by the revolution. She lost her well-established high-class fashion salon, but subsequently either was in charge of, or actively involved in, the various state-initiated institutions dealing with clothes and fashion, and worked simultaneously as a costume designer for theater and film.

### **Westernized NEP Fashion**

When the Bolsheviks finally won over their external and internal enemies in 1921, they had no resources left to implement their avant-garde social and cultural programs. In 1921, with the approval of Lenin, the New Economic Policy (the NEP) was established. By recognizing private ownership and entrepreneurship, the NEP signaled the return of capitalistic practices and a bourgeois way of life. In the NEP circles of newly-rich Russian capitalists, Western fashion experienced a true revival. The designer Alexandra Exter was instrumental in starting the Atelier of Fashion (*Atel'e Mod*) in Moscow, founded in 1923 by the *Moskvochvey* textile company. It was supposed to fulfill two tasks: supplying prototypes for mass production and catering to individual customers. In reality, Exter and her colleagues dressed the new NEP bourgeoisie in highly decorated, luxurious clothes. The aesthetics of the Atelier of Fashion was laid out in a fashion magazine *Atelier*, of which only one issue was published, in 1923. During the NEP period, the Western-style flapper dress found itself in the company of jazz and Hollywood movies, as attitudes toward the Western bourgeois urban culture shifted.

In 1924, Lamanova was put in charge of the artistic laboratory that supplied prototypes for the *Kustexport*, the craftsmen's association founded in 1920 in collaboration with the Ministry for Foreign Trade to export folk art. She and her collaborators (Vera Mukhina, Alexandra Exter, Evgeniia Pribylskaia, and Nadezhda Makarova) agreed on the approach of putting Russian folk motifs on current Western women's wear, and her folk-embroidered day dresses received the Grand Prix at the International Exhibition of Applied Arts in Paris in 1925.

### **Stalinist Representational Dress**

Stalin's rise to power and the introduction of the First Five Year Plan in 1929 brought the NEP to its end. Dur-





**Children walking to school.** Political changes in Eastern Europe heavily influenced fashion, ranging from the austere, functional, classless communist dress during the post-World War II years to a more open attitude toward Western fashion influence in the 1950s. © BETTMANN/CORBIS. REPRODUCED BY PERMISSION.

ing the mid-1930s, the Stalinist regime encouraged social distinctions by creating huge disparities in wages and created a new socialist middle class, which received material goods, from housing to fashion, in exchange for supporting the system. For the first time, communism recognized the relation of fashion to femininity and adornment, allowing its incorporation into the new mass culture that was emerging.

In the mid-1930s, a huge official campaign of civilizing the new socialist middle class dictated, among other things, both good manners and appropriate dress. Stalinism abolished all previous socialist dress styles: the avant-garde, the westernized NEP, and the thematic textiles, which in the late 1920s featured the urgent issues of the day—construction, electrification, and agriculture. Stalinism needed a different, conservative fashion style.

### Moscow House of Fashion

In 1934, fashion consciousness was officially confirmed as part of Stalin's mass culture with the opening of the House of Fashion in Moscow. The established fashion designer Nadezhda Makarova was its first director, while the doyenne of Russian fashion, Nadezhda Lamanova, was appointed artistic consultant. The main task of the designers and the sample-makers engaged by the House of

Fashion was to impose genuine Soviet styles and to make prototypes for mass-production by huge textile companies.

Two luxurious fashion publications, the monthly *Fashion Journal* (*Zhurnal mod*) and the bi-annual *Fashions of the Seasons* (*Modeli sezona*), were designed in the House of Fashion and published under the auspices of the Ministry of Light Industry. In 1937, the same ministry advertised chic hats, fur coats, and perfumes, featuring fashionably dressed and made-up women, contrasting sharply with the poverty-stricken reality. Houses of Fashion were instituted in the other cities and capitals of the Soviet Republics, making clothes production highly controlled and centralized. But in the centrally organized system, which did not recognize the market, access to goods was the main privilege and determined hierarchically. Clothes and fashion accessories were either too expensive or unattainable for the masses.

Whereas the early Bolsheviks rejected even the very word “fashion” and insisted on functional clothing, Stalinism, in a sharp ideological turn, granted fashion a highly representational role. Stalinist dress featured a new Stalinist aesthetic, a blend of Russian folk tradition and Hollywood glamour, appropriate to Stalinist ideals of classical beauty and traditional femininity. The Bolshevik austere and undecorated “New Woman” became a “Super

Woman” during Stalinism, and dresses with accentuated waistlines and shoulders followed her curvy body.

### East European Communist Dress

The Soviet system of centralized production and distribution of clothes was forced on East European countries after 1948, when the communists seized power, regardless of their previously higher levels of technical and stylistic skill in clothing design and production. The East European communist regimes embraced early Soviet ideology, officially rejecting Western fashion. East European communist dress was not only born inside a reality burdened with postwar material poverty, but also inside a reality stripped of all previous clothing references. Clothing was forbidden to evoke beauty or elegance. It was officially claimed that functional, simple, and classless communist dress, which would fulfill all the sartorial needs of working women, would result from serious scientific and technical research.

In the following decades, however, the East European communist regimes’ attitudes toward clothes and fashion were influenced by political changes in the Soviet Union. A new ideological turn occurred when Khrushchev affirmed his rule in 1956 and declared war on excessive Stalinist aesthetics. Leaving the worst practices of Stalinist isolationism behind, Khrushchev opened the U.S.S.R. to the West. In the late 1950s, official attitudes toward Western fashion mellowed in the communist countries. Nonetheless, with neither tradition nor market, and aspiring to control fashion change within their centralized fashion systems, the communist regimes could not keep up with Western fashion trends. By the end of the 1950s, the official version of communist fashion returned to traditional sartorial expressions and practices of traditional femininity, bearing witness to the regimes’ inability to create a genuine communist fashion.

### Communist Fashion Congresses

From that period onward, the official fashions were exhibited in glamorous fashion drawings and photo shoots in state-owned women’s magazines, representative fashion shows, and ambitious presentations at domestic and foreign trade fairs. However, clothing design, production, and distribution remained highly centralized throughout the communist world, leading eventually to serious shortages and dilution of quality. A glamorous official communist version of fashion existed as an ideological construct, despite the shortages and poor quality of clothes in everyday life. Annual fashion congresses between communist countries, at which new fashions were proposed and adopted, began in 1949 and continued through the end of the communist period.

As the need for an official communist fashion increased at the end of the 1950s, when the regimes rushed to clothe their emerging communist middle classes, the fashion congress became more ambitious and rotated among communist capitals, for which participant coun-

tries prepared collections of prototypes. The official communist fashions included orgies of luxurious fabrics and extravagant cuts for excessive evening wear and day wear of ensembles of overcoats and matching dresses or conservative suits, accompanied by ladylike handbags, shoes with high heels, hats, and gloves. This conservative style was diluted into anonymous and moderate dress codes through official womens’ and fashion magazines. Media insistence on timeless and classical sartorial aesthetics conformed with socialist values of modesty and moderation and discomfort with individuality and unpredictability.

As the race between West and East to industrialize transformed into competition over standards of living and consumption, political and social shifts affected communist fashion trends. After decades of rejection of Western fashion, Christian Dior presented a prominent fashion show in Moscow in 1959, and in Prague in 1966. In 1967 an international fashion festival took place in Moscow, presenting both Western and East European collections. Coco Chanel’s presentation was recognized as the best current trend, but the grand prix was awarded to the Russian designer Tatiana Osmerkina for a dress called “Russia.” When mass culture and Western youthful dress and music trends could not be held back anymore, the communist regimes officially recognized a rationalized version of consumption, and the Five Year Plans in the 1960s and 1970s addressed fashion and appearance concerns. The fashions in the plans, however, did not materialize in the shops.

### Everyday and Subversive Dress

Jeans provide the best examples of both the production inadequacies of the planned economies and the futility of their attempting to ignore fashion demands. Domestic production of jeans started in the Soviet Union, East Germany, and Poland only in 1975 but was marked by failures. In 1978, the Soviet media reported that manufacture of a new denim fabric, the fifty-sixth in a row, was officially promised to begin. The official ambivalence toward Western fashion continued throughout communist times, informed by isolationism, fear of uncontrollable fashion changes, and the rejection of the market.

In everyday reality, however, women in those societies found alternative ways of acquiring clothes, from doing it themselves (communist women’s magazines regularly published paper patterns), to the black market, seamstresses, and private fashion salons, which catered to both the ousted prewar elite and the new ruling elite.

Scarcities in state shops and black market activity made Western fashion goods particularly attractive, and the immaculate and fashionable personal look became an ideal for millions of women in communist countries, who were prepared for many sacrifices in order to achieve it. From the end of the 1960s, unofficial channels, with the discreet approval of the regimes, became increasingly important, and dress and beautifying practices occupied an

important position in second societies and economies. Small fashion salons, shoe repair shops, hair salons, and beauty parlors offered goods and services that the state did not provide.

In contrast to the official communist fashion, which suited the slow and over-controlled communist master narrative ideology, everyday dress reflected a wide range of influences, from bare necessity to high fashion. Fashionable street dress undermined the command economy by manifesting change, encouraging individual expression, and breaking through communist cultural isolationism.

But overtly subversive dress also existed in communist countries. Throughout the 1950s, the Soviet “Style Hunters” (*Stilyagi*) had their counterparts in other communist countries, such as *Pásek* in Czechoslovakia and the Bikini Boys (*Bikiniarze*) in Poland. Their rebellious dress codes produced the first elements of a Westernized youth subculture that became very important in the following decades. Western rock arrived in communist countries in the mid-1960s, and, by the 1970s, many domestic rock bands already existed. Youth subcultures, expressing themselves through distinct dress codes, continued to grow throughout the 1970s, and especially in the 1980s, throughout the communist world. Each Western youth trend had its Soviet counterpart, from *metallisti* (heavy metal fans) to *kbippi* (hippies), *panki* (punks), *rokeri* (bikers), *modniki* (trendy people), and *breikery* (breakdancers).

In parallel, the communist regimes allowed the activities of groups who expressed their creativity through dress as an art medium. Because they catered to small numbers of like-minded people, they were believed to pose no threat to official ideology.

In Russia and East European communist countries, the official relationship with fashion was informed by ideological shifts inside the communist master narratives. It fluctuated between a total rejection of the phenomena of fashion in 1920s Russia and in the late 1940s in East European countries to a highly representational role of the official version of communist fashion from the 1950s onward. But the communist regimes failed to produce a genuine communist fashion. From the late 1950s, communist women’s magazines started to promote classical, modest, and moderate styles, which suited the communist fear of change and its ideals of modesty. Throughout the communist times, design, production, and distribution of clothes and fashion accessories were centrally organized, which eventually led to serious shortages and a poor quality of goods. For communist officialdom, fashion could be art or science, but it was never recognized as a commodity. That is the reason why in the other two communist dress practices—everyday and subversive dress—fashionable items retained a large capacity for symbolic investment. While the official communist fashion was an ideological construct unaffected by poor offer of clothes in shops, everyday and subversive dress used a whole

range of unofficial channels, from DIY (do-it-yourself) to black market, private fashion salons and networks of connections. From the 1960s to the end of communism, those unofficial channels grew in importance, and fashionable dress found place inside second societies and second economies in the respective communist countries.

See also **Fascist and Nazi Dress; Military Style.**

#### BIBLIOGRAPHY

- Attwood, L. *Creating the New Soviet Woman: Women’s Magazines as Engineers of Female Identity, 1922–53*. Houndsmill, Basingstoke, U.K., and London: Macmillan, 1999.
- Azhgikhina, N., and H. Gosילו. “Getting under Their Skin: The Beauty Salon in Russian Womens Lives.” In *Russia Women Culture*. Edited by H. Gosילו and B. Holmgren, 94–121. Bloomington: Indiana University Press, 1996.
- Bowl, J. E. “Constructivism and Early Soviet Fashion Design.” In *Bolshevik Culture: Experiment and Order in the Russian Revolution*. Edited by A. Gleason, P. Kenez, and R. Stites, Bloomington: Indiana University Press, pp 203–219, 1985.
- Hlaváčková, K. *Czech Fashion 1940–1970: Mirror of the Times*. Prague, Czech Republic: u(p)m and Olympia Publishing, 2000.
- Kopp, A. “Maroussia s’est empoisonnee, ou la socialisme et la mode.” *Traverses La Mode* 3 (1976): 129–139.
- Pilkington, H. “‘The Future is Ours’: Youth Culture in Russia, 1953 to the Present.” In *Russian Cultural Studies: An Introduction*. Edited by C. Kelly and D. Sheperd, 368–386. Oxford: Oxford University Press, 1998.
- Potocki, R. “The Life and Times of Poland’s ‘Bikini Boys.’” *The Polish Review* 3 (1994): 259–290.
- Ryback, T. *Rock Around the Block: A History of Rock Music in Eastern Europe and the Soviet Union*. New York and Oxford: Oxford University Press, 1990.
- Strizhenova, T. *Soviet Costume and Textiles 1917–1945*. Paris: Flammarion, 1991.
- Vainshtein, O. “Female Fashion: Soviet Style: Bodies of Ideology.” In *Russia Women Culture*. H. Gosילו and B. Holmgren 64–93. Edited by H. Gosילו and B. Holmgren, 64–93. Bloomington: Indiana University Press, 1996.
- Yasinskaya, I. *Soviet Textile Design of the Revolutionary Period*. London: Thames and Hudson, Inc., 1983.
- Zaletova, L., F. Ciofi degli Atti, and F. Panzini. *Costume Revolution: Textiles, Clothing and Costume of the Soviet Union in the Twenties*. London: Trefoil Publications, 1989.

Djurđja Bartlett

**CORDUROY** Many sources claim the origin of the word is derived from the French *corde du roi* or “the king’s cord.” The fabric was supposedly used to clothe the servants of the king in medieval France. However, there are no written documents to credit this etymology. It is more likely that the term originated in England, from a fabric called “kings-cordes,” which is documented in records in Sens, France, from 1807. Another possible origin of the name may be from the English surname Corderoy. This



spelling was used in reference to the fabric as early as 1789 in America in a newspaper advertisement from a corduroy weaver in Providence, Rhode Island.

Corduroy is a durable fabric that is woven with three sets of yarns and has vertical ribs, or wales, that are formed by cut-pile yarn. The third set of yarns, which is generally loosely spun, is woven into a plain or twill weave backing in the filling direction to form floats that run over four or more warp yarns. A corduroy with a plain-weave backing may be referred to as “tabbyback,” and a twill-backed corduroy can be called a “Genoa-back.” Twill backing is more durable because the weave is denser and the pile tufts are held more tightly. The floats are cut after weaving to form ribs through the use of specialized machinery. The uncut fabric is run through the cutting machines once for ribs that are widely spaced apart and twice for closely-set ribs. The ribs are rounded with the longest floats in the center and the shorter floats on either side. After the pile is cut, the fabric is often singed and brushed to produce an even-ribbed finish.

Corduroy may be piece-dyed or printed in patterns and is named according to the number of wales per inch. Variations of corduroy include featherwale, pinwale, medium wale, thick-set corduroy, broad wale, wide wale, and novelty wale corduroys, in which different widths of wales are arranged in patterns.

Corduroy is used for trousers, shirts, jackets, skirts, dresses, and in home furnishings such as pillows and upholstery. Developments in the production of corduroy include the addition of spandex to provide more stretch in the fabric that is used for close-fitting garments.

See also **Napping**.

#### BIBLIOGRAPHY

- American Fabrics Encyclopedia of Textiles*. 2nd edition. Englewood Cliffs, N.J.: Prentice Hall, 1972.
- Gioello, Debbie Ann. *Profiling Fabrics: Properties, Performance & Construction Techniques*. New York: Fairchild Publishing, 1981.
- Kadolph, Sara J., and Anna L. Langford. *Textiles*. 9th edition. Englewood Cliffs, N.J.: Prentice Hall, 2002.
- Linton, George E. *The Modern Textile and Apparel Dictionary*. 4th edition. Plainfield, N.J.: Textile book service, 1973.
- Montgomery, Florence M. *Textiles in America 1650–1870*. New York: W.W. Norton and Company, 1984.
- Wingate, Isabel, and June Mohler. *Textile Fabrics and Their Selection*. 8th edition. Englewood Cliffs, N.J.: Prentice Hall, 1984.

Marie Botkin

**CORSET** The corset is a garment with a long and controversial history. A rigid bodice, usually incorporating vertical and diagonal boning, and laced together, the corset was designed to shape the female torso to the fash-

ionable silhouette of the period. Corsets have been worn by women in the Western world from the sixteenth century through the early twentieth century, at which point girdles and brassieres replaced them. Men, especially dandies and military officers, have also sometimes worn corsets. The primary significance of the corset, however, is its role as an essential element of women’s fashionable dress for a period of about 400 years.

Throughout its history, the corset was frequently criticized as an “instrument of torture” and a cause of ill health and even death. Feminist historians have often argued that corsetry functioned as a coercive apparatus through which patriarchal society controlled women and exploited their sexuality. Recently, some historians have questioned this interpretation, arguing that corsetry was not one monolithic, unchanging experience that all women endured, but rather a situated practice that meant different things to different people at different times. Some women did experience the corset as an assault on the body. But for others, the corset also had positive connotations of social status, self-discipline, respectability, beauty, youth, and erotic allure. This revisionist view, which aims for a balanced and non-ideological history of corsetry based on carefully considered evidence, must not be confused with the uncritical defenses of corsetry that have been published by corset “enthusiasts.” As for the long-standing claim that corsets were a source of disease and death, historians continue to disagree about the medical consequences of corsetry.

The word “corset” derives from the French *corse*, which simply designated a bodice. Early corsets were known as *corps à la baleine* (or in English, whalebone bodices), because strips of whalebone, or, more accurately, whale baleen, were inserted into the fabric (usually linen or canvas) to stiffen the cloth bodice. As whalebone became more expensive in the nineteenth century, lengths of steel increasingly replaced it. Traditionally, down the center front of the corset was inserted a *busk*, which, in shape and size, was not unlike a ruler. Busks were variously made of wood, horn, and whalebone; they were often elaborately carved and given as lovers’ gifts. By 1850 the traditional, inflexible one-piece busk had been replaced by a steel, front-opening style, which made it much easier for women to put on and take off their corsets. Prior to this, women had usually relied on assistance to lace and unlace their corsets.

Corsets were also known as “stays,” a term probably derived from the French *estayer* (to support), since they were thought to support the body. Because women were looked upon as the “weaker sex,” it was commonly believed that their bodies habitually needed additional support. For similar reasons, children were also often placed in stiffened bodices, which were supposed to make them grow up straight. However, by the eighteenth century, many doctors argued that children’s bodies were more likely to be deformed by corsets that were too tight. They also increasingly warned that women were endangering

their health (and that of their unborn children) by wearing corsets. Over the course of the nineteenth century, medical journals published numerous articles criticizing corsetry. Yet the vast majority of middle- and upper-class women continued to wear corsets, and increasing numbers of working-class women also adopted corsets.

In her book, *Health and Beauty; or, Corsets and Clothing Constructed in Accordance with the Physiological Laws of the Human Body* (London, 1854), the English corsetière Madame Roxey A. Caplin defended corsets—at least if they were well-made: “It never seems to have occurred to the Doctors that ladies must and will wear stays, in spite of all the medical men of Europe.” Because women “desire to retain as long as possible the charm of beauty and the appearance of youth,” they wear corsets, which conceal “defects” (such as a thick waist or belly) and give support “where it is needed” (for example, in the absence of brassieres, corsets support “the fullness of the breasts”). Caplin even claimed that a French doctor had told her, “Madame, your corset is more like a new layer of muscles than an artificial extraneous article of dress!” It would be many years, however, before the majority of women stopped relying on corsets and started developing their own muscles.

The history of the corset is replete with myths and exaggerations. For example, the notorious “iron corsets” of the Renaissance were not fashion items worn by the ladies at the court of Catherine de Médicis, as is often claimed. Rather, they were orthopedic braces meant to correct spinal deformities. (Some of these metal corsets are also modern forgeries.) Accounts of extreme tight lacing are also problematic. During the second half of the nineteenth century, several English periodicals, most famously *The Englishwoman's Domestic Magazine*, published numerous letters purporting to describe how the authors had achieved waists of fifteen inches or even less. Although fashion historians and journalists have frequently quoted excerpts from this “corset correspondence,” they cannot be taken at face value. Both internal and external evidence indicate that many of these letters represent sexual fantasies rather than descriptions of authentic experiences. Certainly the scenarios described, which often focused on coercive practices at anonymous boarding schools, were not typical of the average Victorian girl or woman, although they may reflect the role-playing practices of fetishistic subcultures.

Thorstein Veblen, author of *The Theory of the Leisure Class* (1899), famously described the corset as “a mutilation undergone for the purpose of lowering the subject’s vitality and rendering her permanently and obviously unfit for work.” In reality, however, ladies of the leisure class were not the only ones to wear corsets. By the mid-nineteenth century, with the development of cheap, mass-produced corsets, many urban working-class women also wore corsets. Clearly, the corset did not render them unfit for work, but did it lower their vitality?

## Thomson's New Styles Glove-Fitting Corset.

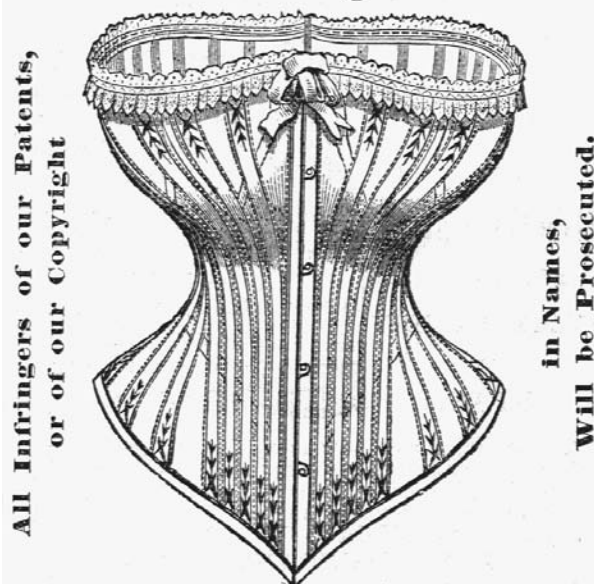

### THE VENTILATING OR SUMMER CORSET.

Entirely NEW in Style and Perfect in Shape.

The **Curvilinear**, rich and elegant in finish.

Also, a lower cost “**Glove-Fitting**” than ever before offered; which, with our former regular qualities, make the assortment complete.

These justly celebrated **PATENT GLOVE-FITTING CORSETS** are constantly gaining favor in the United States as well as in foreign countries.

Always ask for **Thomson's GENUINE GLOVE-FITTING, every Corset being Stamped.**

**THOMSON, LANGDON, & CO.,**  
Sole Patentees, **391 BROADWAY, N. Y.**

**Nineteenth-century advertisement for corsets.** Although many doctors warned of various health risks related to the wearing of corsets, the rigid bodices were a common clothing item for centuries. © CORBIS. REPRODUCED BY PERMISSION.

Certainly many eighteenth- and nineteenth-century doctors regarded the corset as a health hazard. They blamed the corset for causing dozens of diseases, including apoplexy, asthma, cancer, chlorosis (a type of anemia), curvature of the spine, deformities of the ribs, damage to internal organs such as the liver, digestive disorders, respiratory and circulatory diseases, and birth defects and miscarriages. Other doctors, however, approved of “moderate” corsetry, condemning only “tight lacing” (a notoriously imprecise term). In 1785, Dr. von Soemmering published comparative illustrations of corseted and uncorseted rib cages, which indicated that corsetry caused permanent deformity. Twentieth-century X-rays also show that a tightly laced corset compresses the ribs and

moves the internal organs, although when the corset is removed, the body seems to revert to its normal appearance.

During the nineteenth century, relatively little was understood about the causes of various diseases, to say nothing of the treatments. One cannot, therefore, automatically accept the diagnoses of nineteenth-century doctors, many of which are patently absurd. This is not to say that corsets were totally harmless. Most authorities today agree that extremely tight corsets might risk various kinds of physical impairment or harm. There is no consensus among experts, however, on what risks were involved in ordinary corset wearing. Although contemporary scholars disagree about how dangerous corsets really were, corsets undoubtedly did contribute to some health problems. Spirometry (lung volume) testing conducted by Colleen Gau and her associates has demonstrated that corseted women suffered depleted lung volume, as well as changes in breathing (from normal diaphragmatic breathing to reliance on the accessory muscles of the chest wall). Lessened lung capacity would not necessarily contribute to respiratory disease, but it could certainly lower vitality and cause fainting. This would seem to lend credence to nineteenth-century accounts that associated corsetry with shallow breathing and fainting. In the 1880s, using an adaptation of the sphygmomanometer (blood pressure machine), the New York obstetrician Robert L. Dickinson measured corset pressure on several hundred women, recording pressures as high as eighty-two pounds per square inch. He believed that corset pressure caused digestive and breathing problems, as well as serious effects on the reproductive organs, such as prolapse of the uterus. It is sometimes alleged that some women underwent the dangerous surgical procedure of having their lower ribs removed in order to achieve a smaller corseted waist. There is, however, no evidence at all that any Victorian woman ever had her ribs removed; rib removal appears to be entirely mythical.

Some doctors and corsetiers tried (or claimed) to develop safer and more comfortable corsets. During the 1890s, for example, Dr. Inez Josephine Gaches-Sarraute designed the so-called straight-front corset, which she described as a “health” corset. However, recent physiologic testing using reenactors found the straight-front corset to be more uncomfortable and constraining than the hourglass styles of the mid-Victorian era.

The shape and construction of the corset changed dramatically over time, but there was no simple progression toward greater ease. Between about 1790 and 1810, the rigid cone-shaped stays of the eighteenth century were temporarily abandoned in favor of a shorter, lighter style, some variants of which resembled a brassiere. However, as high-waisted Empire dresses gave way to lowered waists and fuller skirts, the boned corset reemerged. Now, however, it was shaped more like an hourglass. Over the course of the nineteenth century, technological developments, such as steam molding, contributed to-

ward the fashion for long *cuirasse* corsets. At the turn of the century, the fashionable straight-front corset pushed the pelvis back and the bosom forward, creating the so-called S-silhouette. Yet as women engaged in more sporting activities, such as bicycling, they increasingly adopted flexible elasticized sports corsets. By the 1920s elastic girdles and brassieres had largely supplanted rigid corsets, particularly among the young. In 1939, and again after World War II, fashion showed renewed emphasis on femininity and the corset had a brief resurgence in the form of the “Merry Widow” or *guépière* (waspy).

By the 1960s and 1970s, however, a cultural focus on youth and body exposure resulted in greater reliance on diet and exercise, rather than foundation garments, to create a desirable figure. The corset was, thus, not so much abandoned as it was internalized through diet, exercise, and later, plastic surgery. A minority of corset enthusiasts, both male and female, continue to wear corsets and sometimes tight lace as part of fetishistic, cross-dressing, or sadomasochistic practices.

Beginning in the 1980s, inspired by subcultural fetish styles, avant-garde fashion designers, such as Vivienne Westwood and Jean Paul Gaultier, began to create corset fashions. Madonna famously wore a pink satin corset by Jean Paul Gaultier on her *Blonde Ambition* tour of 1991. Since then, every few years the fashion press reports on the reappearance of corsets by couturiers such as Christian Lacroix, Alexander McQueen, and Donatella Versace. Although some of these corsets incorporate lacing and (plastic or metal) boning, most are really more like zip-up bustiers than historic corsets. Cheaper versions are popular as club wear for both young men and women.

See also **Brassiere; Europe and America: History of Dress (400–1900 C.E); Gender, Dress, and Fashion; Girdle.**

#### BIBLIOGRAPHY

- Steele, Valerie. *The Corset: A Cultural History*. New Haven, Conn., and London: Yale University Press, 2001.
- Summers, Leigh. *Bound to Please*. Oxford: Berg; distributed by New York University Press, 2001.

*Valerie Steele and Colleen Gau*

**COSMETICS, NON-WESTERN** The earliest evidence of the role of cosmetics in human society was found in the remains of artifacts used for eye makeup in Egypt of the fourth millennium B.C.E. Anthropological research also shows that there are several ways used by humans to transform the physical and social appearance of their bodies into cultural manifestations. People use their bodies and faces as objects of aesthetic elaboration or as a medium through which they can project themselves in religious and social life. We can thus identify two distinct, though related, senses of the term “non-Western cosmetic.” The first pertains to personal taste and is con-





**Wahgi tribe members.** In tribes such as this one in New Guinea, paints are used to portray the varying physical and emotional aspects of their community, both positive and negative. © CHARLES & JOSETTE LENARS/CORBIS. REPRODUCED BY PERMISSION.

cerned with the decorative/aesthetic aspect of non-Western cosmetic. The second is more general and is related to ritual and the symbolic essence of body decoration.

The ubiquitous interpretation of non-Western cosmetic in modern society is associated with the aesthetic or decorative. It is concerned with the visual and is related to personal style and denotes what is considered beautiful or fashionable. Non-Western cosmetic, in this case, is used in order to make a fashion statement. It is generally considered an exclusively feminine pursuit, used to aesthetically enhance the beauty of the person. Cosmetic and fashion industries make such physical appearances readily available under the rubric of the ethnic/tribal/oriental look. This look is epitomized by photographic studies of non-Western artistic practices and peoples confined to identifying what may be considered exotic and beautiful to the Western eye (Reifenstahl 1986; Ebin 1979; McCurry 1997).

Products originating from Africa, Asia, and South America and conceptualized in terms of respect for traditional beauty, natural or local ingredients, and non-animal tested products are sold in modern containers. This is

meant to bring to mind ideas of purity, health, animal welfare, sunshine, adventure, travel, leisure, serenity, even exoticism and eroticism. Materials used include kaolin, henna, kohl, burnt cork, chalk, clay, and all sorts of vegetable, flower, and plant extracts. The growing demand for an exotic look in fashion has warranted their manufacture on a commercial scale. Production techniques, packaging, and advertising have helped to increase worldwide usage of such products. The best-known leader of this trend is the Body Shop.

The image industry created by advertising agencies mediates the changing aspect of the human body image through fashion and art in glossy magazines and books. This has privileged the aesthetic/decorative and attenuated the transcendent nature of the art of body painting (Baudrillard 1994). Conversely, in tribal and non-Western societies, the aesthetic aspect of body and face decoration often emphasizes the social aspect of the human body (Leach 1966). Non-Western cosmetic can thus be understood by looking into the interpretative properties of cosmetic in terms of rituals and symbols. This is especially helpful for clarifying the meaning of body adornment during festivities, ritual ceremonies, or even everyday occasions. For example, Tilaka is a vermilion



**Henna tattoos.** This reddish-orange dye is used by women in Africa and Asia to create elaborately beautiful tattoos, and by both women and men as a hair colorant. © CHARLES O'REAR/CORBIS. REPRODUCED BY PERMISSION.

mark applied on the forehead by Indian women as a sign of being in wedlock. It is also used by both sexes as a culturally designed communication code, which embodies ritual and sacred symbols. Although red predominates, a variety of other pigments such as yellow, white, gray, saffron, and black are employed. In some cases these pigments are applied on the forearms and the abdomen as well. The origins of these practices are said to lie in a primitive tribal past. This is the case of followers of Shiva, a deity worshiped by proto-Aryan societies in the Indian subcontinent. Even today, the smearing of colors on arms, torso, or face is an essential aspect of the Hindu festival of Holi.

Women and men wear the Tilaka as a sign of belonging to the Hindu religion. Its versatile form, shape, and color also indicate adherence to the various Hindu sects and subsects. Worshipers of the Lord Vishnu apply a "U" sign made of a mixture of red ocher powder (*Sindhura*) and sandalwood paste (*Gandab*). Worshipers of the Lord Shiva prefer to draw three horizontal lines made of ash (*Abhira*). For men the application of Tilaka, made up of their own blood, is an indication of solemn commitment to an oath or a pledge being undertaken (Kelly 2002).

In tribal societies of tropical and equatorial regions the visual and interpretative value of body adornment is used as a schematic representation of values, beliefs, symbols, and myths. Differing pigments and patterns are used for instant recognition of group identity, social status, or age group, while still allowing for gender differences and personal idiosyncrasy. The most elaborate forms of decoration involve lengthy preparation, much care and expense, and hence are generally seen on ceremonial and ritual occasions. Men and women employ a combination of colors and designs in order to make a statement about the nature of a particular occasion. The adornment favored by individuals or group participants is intrinsic to the ceremony and is vital for conveying messages about the community's social and religious values.

The Melpa and Wahgi of Papua New Guinea use body decoration as an essential part of ritual performances and gift exchange ceremonies. During happy occasions men paint their bodies and weapons with white wavy lines intended to represent patterns reflected in water. They adorn their faces with white and red pigments and place similar feathers and flowers in their hair to evoke "brightness." Bright colors symbolize the physical and moral strength, vitality, and well-being of the community. Conversely, war paint is deliberately meant to transform the human body into a terrifying warrior. In times of war, bodies are covered with a deep black charcoal-based pigment, a color associated with poison. Faces and accessories are similarly decorated with dark hues to transmit the message of aggressive power and fierceness. Women in Papua New Guinea wear less brilliant body decoration emphasizing their primarily domestic and agricultural duties. Similarly Australian aborigines paint their body and faces with white clay dots and lines prior to going hunting or war as a protective measure. They also decorate their bodies during initiation ceremonies or when they re-enact stories of their mythical past through music and dancing (Ebin 1979; O'Hanlon 1989, 1992; Strathern and Strathern 1983; Groning, 1996).

In parts of Africa and South America, design and color are used to separate the sexes and invoke magical powers, which are believed to be inherent in nature and the spiritual world. Tchikrin men from Central Brazil paint their bodies white and black; women prefer yellow and red. The Kayapo Indians of Brazil make a connection between the color red and abstract qualities such as heightened sensory sensitivity, energy, and health. They smear red pigments on their faces, hands, and feet, because they associate these parts of the body with swiftness, agility, and sensory contact with the outside world. Black is applied to the torso and signifies the integration of the inner man into social life (Turner 1969). Turning to West Africa, shamans in the Ivory Coast paint their eyes with white clay mixed with herbs and water from "sacred rivers" in order to see into the spirit world. Ghanaian priestesses smear their faces with white clay and paint parallel lines across their foreheads and cheeks.

The color white represents the divine nature of the gods, while parallel lines are meant to deflect the attacks of evil mystical beings. Ashanti women from Ghana draw designs on their arms with white clay to invoke mythical protection for themselves and their babies after giving birth (Ebin 1979; Fisher 1984; Groning 1996).

People's preoccupation with rituals and symbols in social life often merges with their purely aesthetic impulses to decorate their bodies. Young Nuba men from the Sudan spend long hours applying elaborate designs all over their bodies to enhance the beauty, elegance, and well-being of their bodies. Their adorned bodies become a field upon which they demonstrate their physical beauty, sexual attractiveness, or personal status. Particular patterns or colors are used to portray in visible terms the individual's progress from infancy through puberty and adulthood or personal status within society. Deep yellow and jet black are only allowed to older age groups. Younger age groups are immediately recognizable by their use of red ocher and simpler hairstyles. The decline in physical strength and attractiveness in old age compels old men to cease to decorate their bodies, shave their heads, and start wearing cloth. Nuba women wear appropriate colors indicating their membership in a particular kinship group (Faris 1972; Brain 1979; Ebin 1979; Strathern and Strathern 1983; Riefenstahl 1986). The above examples of body and face decoration are not merely indicative of our tribal past. They are kept alive in the Western imagination through books on art and photography and their many fashion conscious modern imitators (Thevoz 1984; Vale and Juno 1989; Randall and Polhemus 2000)

See also **Cosmetics, Western.**

#### BIBLIOGRAPHY

- Brain, Robert. *The Decorated Body*. London: Hutchinson, 1979.
- Baudrillard, Jean. *Simulacra and Simulation. The Body in Theory: Histories of Cultural Materialism*. Ann Arbor: University of Michigan Press, 1994.
- Ebin, Victoria. *The Body Decorated*. London: Thames and Hudson, Inc. 1979.
- Faris, James. *Nuba Personal Art*. London: Duckworth, 1972.
- Fisher, Angela. *Africa Adorned: A Panorama of Jewelry, Dress, Body Decoration and Hair Style*. New York: Harry N. Abrams, 1984.
- Groning, Karl. *Body Decoration: A World Survey of Body Art*. New York: Vendome Press, 1996.
- Kelly, Kevin. *Asia Grace*. Cologne, Germany: Taschen GmbH, 2002.
- Leach, Edmund. "Ritualisation in Man." *Philosophical Transactions of the Royal Society* 251 (1966).
- McCurry, Steve. *Portraits*. Bombay, India: Phaidon Press Ltd., 1997.
- O'Hanlon, Michael. *Reading the Skin: Adornment, Display and Society Among the Wabgi*. London: Trustees of the British Museum by British Museum Publications, 1989.

———. "Unstable Images and Second Skins: Artifacts, Exegesis and Assessments in the New Guinea Highlands." *Man* 27, no. 3 (1992): 587–608.

Randall, Housk, and Ted Polhemus. *The Customized Body*. London: Serpent's Tail, 2000.

Riefenstahl, Leni. *The Last of the Nuba*. London: Collins Harvill, 1986.

Strathern, Andrew, and Marilyn Strathern. *Self-Decoration in Mt. Hagen*. Toronto: University of Toronto Press, 1983.

Thevoz, Michel. *The Painted Body*. New York: Skira/Rizzoli International, 1984.

Turner, Terence. "Tchikrin, A Central Brazilian Tribe and Its Symbolic Language of Bodily Adornment." *Natural History* 18, (1969).

Vale, V., and Andrea Juno, eds. *Modern Primitives: An Investigation of Contemporary Body Adornment and Ritual*. San Francisco: RE/Research Publications, 1989.

Paula Heinonen

**COSMETICS, WESTERN** In the twenty-first century, cosmetics include a full range of products to protect the skin and improve appearance, from moisturizers to makeup, manufactured by a multibillion-dollar, global cosmetics industry. Before the twentieth century, however, cosmetics were understood differently in Western cultures. In English, the word "cosmetic" referred to skin-improving substances, such as creams and lotions. Cosmetics to mask or color the skin were known as "paint" or, in a theatrical context, "makeup." This fundamental distinction was a legacy of the ancient world, and shaped the early use of cosmetics.

#### Cosmetics Before 1900

In the seventeenth and eighteenth centuries, European women prepared simple cosmetics from recipes appearing in household manuals and cookbooks or passed on orally from generation to generation. In that period, cosmetics were as much science as art, a branch of self-help therapeutics that women were expected to master. Recipes in early household manuals called for roots, wildflowers, and other plants to be mixed with water, beer, vinegar, and spices; these produced remedies to clear the complexion, improve color, and remove signs of smallpox. The principles governing these mixtures were based on Galen's theory of the humors, in which the correspondence between internal and external organs, and the balance between hot, cold, dry, and moist qualities, was the key to health and beauty. In addition, belief in the power of nature's cycles and astrology found their way into beauty preparations, in recipes using May dew, the first juice of spring plants, and "virgin milk."

Colonial Americans used similar cosmetic recipes, preparing cold cream, skin lotions, and lip salves from such common substances as wax, lard, nut oils, and sugar. They also incorporated the flowers and herbs of





**Elizabeth Arden.** The Canadian-born Arden opened a New York salon on Fifth Avenue in 1910, installing the trademark bright red door to make her shop distinctive. © HULTON-DEUTSCH COLLECTION/CORBIS. REPRODUCED BY PERMISSION.

the New World, such as puccoon-root or “Indian paint,” prevalent in Algonquin therapeutics. Africans brought to the colonies as slaves similarly adapted native plants into traditional West African techniques of grooming and beautifying, using berries and roots to redden the skin, for example.

In addition to home preparations, a small but significant global trade made exotic herbs, extracts, dyes, and proprietary cosmetics available to the wealthy in the early modern period. French and English court society encouraged the use of enamels, white powder, rouges, and beauty marks to enhance appearance, serve fashion, and cover pockmarks and other disfigurements, and colonial elites followed suit. These paints, powders, and enamels to whiten the skin often contained dangerous substances, such as arsenic and lead, jeopardizing health while creating brilliant effects. Perfumers, hairdressers, and apothecaries in major cities offered fashionable cosmetics to both women and men. Until the early nineteenth century, cosmetics tended to mark rank as much as gender; they connoted gentility, social prestige, and political standing, and were as much a part of high culture as ornamental clothing and tea drinking.

Fashionable cosmetics became a source of controversy, however, in Europe and America. Puritans condemned painting as a mark of vanity and defiance of the divine order; masking the face falsified one’s true identity. The American Revolution placed a political perspective on such cosmetics, valuing the plain appearance

of republican virtue over the foppery of aristocratic men. In the early nineteenth century, the religious sensibilities and domestic ideals of an emergent middle class in the North emphasized both natural beauty and women’s duty to be beautiful, to be achieved through healthful regimens and a moral life. White southern women, especially those on plantations, held onto the earlier ideals of gentility that permitted powder and rouge. Still, the association of cosmetics with prostitution—the “painted woman”—remained a strong one through the 1800s, and women who dared to use cosmetics did so covertly and with a light touch.

Sales of skin creams and lotions grew through the middle of the nineteenth century, but they remained small in scale when compared with such commodities as patent medicines and soaps. According to an 1849 manufacturing census, thirty-nine toiletries firms produced only \$355,000 in merchandise in the United States. Nevertheless, the expansion of the market in this period made formerly rare preparations more available and affordable. Typically pharmacists would use a range of chemicals, herbs, and oils to “put up” skin creams under a house label. Commercial agents also imported goods from around the world, including English patent preparations, French perfumes, Portuguese rouge dishes, and Chinese color boxes, containing color-saturated papers of rouge, pearl powder, and eyebrow blacking.

The most commonly used cosmetics of the nineteenth century, however, were skin whiteners and bleaches. Advertisements claimed they removed tan and freckles and made women look more refined and genteel. These were directed at white, middle-class women, playing on their social aspirations, as well as working-class, immigrant, and black women.

### Cosmetics Use and the Beauty Industry

Cosmetics use began to increase in the late nineteenth century, a consequence of several key developments. Embracing photography and the theater, Americans became newly oriented to visual culture and social performances. In retailing, innovative department stores used mirrors, plate glass, and the latest fashions to encourage women to engage in self-scrutiny and display.

Many cosmetics businesses began as manufacturers of perfume, soap, and patent medicines and initially went into beauty aids as a sideline. Ponds, one of the leading sellers of skin-care products, started out making patent medicines; in an early instance of market research, it discovered a demand for skin-care products in the 1890s. By 1910, Ponds’s advertising promoted cleansing cream at night and vanishing cream by day as a regular beauty treatment for women.

Most important, beauty salons and manicure parlors began to spring up in the nation’s cities. These popularized a concept of “beauty culture,” encouraging women to improve their looks systematically, using proper cos-



**Cosmetic counter.** Most major cosmetic lines have displays in department stores, complete with beauticians to demonstrate the products and make recommendations to customers. © GREG SMITH/CORBIS SABA. REPRODUCED BY PERMISSION.

metics and facial techniques. Emphasizing cleanliness, grooming, and skin care, they also sold tinted face powders, whitening creams, rouge, and lip pomades. Women entrepreneurs pioneered the new beauty culture and some became early leaders of the cosmetics industry. Helena Rubinstein and Elizabeth Arden created their New York salons in the 1910s; each developed a full line of cosmetics for facial treatments and home use. By World War I, each had expanded operations into manufacturing and distribution at the “class” end of the market, selling in exclusive stores, specialty shops, and a growing number of salons.

The Parisian fashion for *maquillage* was slow to be accepted in the United States, although by the 1910s style setters and socialites were purchasing French-made rouge and powder. Helena Rubinstein, Elizabeth Arden, and other women in the beauty business encouraged affluent American women to use makeup and quietly offered applications in their salons.

African American entrepreneurs also found a market for cosmetics within black communities. In the early twentieth century, Anthony Overton developed a “High Brown Face Powder” specifically for women with darker complexions. Although focusing on hair treatments, busi-

nesswoman Madam C. J. Walker also expanded her product line to include skin creams and powders for black women. Neither created products for the full range of African American skin tones at this time, but both sought to address black women’s dignity and desire for good looks. In contrast, many of the cosmetics sold to African Americans manufactured by white-owned companies relied on blatantly racist appeals to bleach skin and look white. Such products were widely advertised in black newspapers and remained a subject of controversy through the twentieth century.

What is especially striking about cosmetics at this time, however, is the popularity of beauty preparations among workingwomen, including the daughters of immigrants. They embraced powder and paint, along with fashionable clothing, to assert a new sense of individuality. In the early twentieth century, when sexual mores were changing and young women had entered the workforce in large numbers, the “painted woman” could no longer be distinguished as a prostitute. Indeed, by the 1920s, women increasingly used the term “makeup” rather than “paint,” thus indicating that cosmetics were not a means of covering up one’s looks but rather an integral part of a public persona.



**Beauty kit.** In the early 1900s, cosmetics began being packaged for portability, increasing their popularity. © CONDÉ NAST ARCHIVE/CORBIS. REPRODUCED BY PERMISSION.

Growing through the 1910s, the cosmetics industry took off after World War I. From 1909 to 1929, the number of American perfume and cosmetics manufacturers nearly doubled; by 1929, Americans were spending \$700 million annually for cosmetics and beauty services. The transformation of women's appearance in the 1920s—corsetless and revealing clothing, bobbed hair, a thin body image—went hand-in-hand with the increased consumption of beauty products and makeup.

Still, cosmetics use spread unevenly across the United States and Europe, more popular among the young, employed, and urban women than their mothers or small-town sisters. Surveys of nonurban women's daily regimens in the 1920s showed that most simply washed the face with soap and water, then perhaps applied cold cream or white powder. It was not until the end of the 1930s that farm women's use of cosmetics approximated that of city dwellers.

A number of innovations in cosmetics and packaging appeared in this time. French cosmetics firms had produced finely textured and tinted powders, and American firms followed suit, selling a wider range of shades. These included, in the mid-1920s, powders and rouges to complement suntanned skin, which had become a popular craze. Metal compacts and lipstick tubes emphasized the portability of cosmetics, so that women could touch

up throughout the day. Vanishing cream was typically used as a base for powder, but foundations began to appear in the 1930s. Among the most innovative and successful was Max Factor's Pan-Cake, a water-soluble foundation in cake form, invented for use by motion picture actors, then introduced to the general public in 1938.

In the first half of the twentieth century, however, most cosmetics manufacturers followed standard formulas, modifying basic creams, lotions, and other preparations. Firms selling lipstick, rouge, and eye makeup often depended on "private label" manufacturers, who offered similar products with small variations. Scientific discoveries led companies to make new claims for wrinkle removers, and small amounts of vitamins, hormones, and even radium were added to skin creams. By the 1930s, the public paid heightened attention to the composition of cosmetics and the exaggerated claims of advertisers. Consumer advocacy groups highlighted cases where women had been blinded by aniline dyes in mascara or burned by skin bleaches that contained a high percentage of ammoniated mercury, common in whiteners sold to African American women. Such concerns led to the increased regulation of cosmetics in the United States and passage of the Food, Drug, and Cosmetics Act in 1938.

It was advertising and marketing, more than product development, that spurred the expansion of the beauty industry and cosmetics use. Cosmetics and toiletries were heavily advertised in women's magazines, second only to food items, and appeared frequently in general interest magazines, in newspapers, and by the 1930s, on radio. These advertisements invoked aspirational images of beauty, youth, and romance, on the one hand, but also touched anxieties about social competition and failed romance, especially during the Great Depression. Hollywood also played an important role; motion picture actresses established new beauty ideals and endorsed a range of products, including mascara and eye shadow, cosmetics few women wore at the time. Whether sold in department stores or five-and-dimes, cosmetics were often an impulse purchase; retailers set up eye-catching displays in the central aisles of their stores and hired saleswomen to demonstrate beauty techniques and promote specific brands.

### Postwar Expansion

By the 1940s, makeup had become accepted as an integral dimension of women's everyday appearance. Home economics courses taught how to use makeup in classes on good grooming; department stores held beauty days for schoolgirls; white-collar personnel offices looked favorably on job candidates with carefully applied lipstick and rouge. Psychologists and other professionals insisted that cosmetics were essential to women's mental health and a mature feminine identity.

During World War II, bright red lipstick became a sign of women's patriotism among the Allies. As women



went into industry in record numbers, they continued to use cosmetics to affirm their femininity and boost their morale. When the American government tried to restrict cosmetics as a conservation measure in 1942, it found itself backpedaling six months later. Although discontinuing metal containers and limiting some ingredients, it nevertheless made a wide range of beauty preparations available.

Cosmetics use increased dramatically in the postwar world. Women purchased cosmetics to complement seasonal changes in fashion, buying wardrobes of lipstick and nail polish. As the market for cosmetics matured, the beauty business created distinctive brands intended to appeal to women according to demographics and lifestyle. Maybelline, Revlon, and Noxzema (Noxell)—small-scale firms that before the war had specialized in eye makeup, nail enamel, and skin cream, respectively—became large corporations with extensive product lines. New women entrepreneurs also emerged after World War II, including Estee Lauder and Mary Kay Ash. Home-based selling proved highly successful in this period. Avon, founded in 1886, used door-to-door sales to expand from rural communities and cities into the burgeoning postwar suburbs. Using the multilevel marketing strategy pioneered by earlier black businesswomen, Mary Kay organized home parties for women to learn about and purchase cosmetics.

Postwar youth culture spurred cosmetic firms to market cosmetics especially for teenage girls. Noxzema's Cover Girl offered sheer, medicated foundations and lighter tints as a "clean makeup" that would appeal to both teens and their parents. In the early 1960s, the sale of eye makeup—mascara, eyeliner, and colorful eye shadow—finally took off, an aesthetic trend among young women that coincided with the miniskirt and long hair of the time. Grooming aids, powder, and lip gloss for young girls appeared as early as the 1950s; by the 1970s, toy companies and major cosmetics firms competed for these juvenile consumers.

Market segmentation meant that advertising varied considerably in this period. Compared with their prewar counterparts, however, advertisements in the 1950s and 1960s more boldly accentuated women's sexuality and need to appeal physically to men. Revlon's Fire and Ice campaign in 1952 cast a playful yet erotic and charged aura around a medium-red lipstick. During the "British Invasion" of the 1960s, Mary Quant's Love Cosmetics used phallic packaging and Mod design to tie teen cosmetics to the sexual revolution.

### Politics of Cosmetics

By the mid-1960s, the counterculture and a nascent feminist movement attacked these trends in advertising, the commercialization of beauty, and women's sexual objectification in the media. Embracing a "natural" look, some women gave up makeup entirely, while others began to

compound their own creams and lotions using herbs, berries, and other organic ingredients. Major cosmetics firms were slow to respond to this challenge. Estee Lauder introduced Clinique in 1968, emphasizing a scientific and hygienic appeal. A number of cosmetics lines appeared that contained natural ingredients and were not tested on animals; these often sold in food coops or other alternative outlets. The Body Shop, founded by Anita Roddick, became highly successful marketing to women sensitive to the environment and influenced by the counterculture.

In the 1960s and 1970s, women of color also protested the narrow images of beauty that appeared in fashion magazines and limited cosmetics lines available to them. African American businesses like Fashion Fair and entrepreneurs from the post-1965 immigrant groups have created niche makeup lines for black, Latina, Asian-American, and other women. Increasingly attuned to American ethnic diversity and the global economy, corporations like Maybelline began to manufacture foundation and other cosmetics for the full range of human skin tones.

The feminist critique of cosmetics continued to be heard in the last decades of the twentieth century, notably in the 1991 best-seller *The Beauty Myth*. That critique, in turn, was challenged in the 1980s and 1990s by postfeminists, postmodernists, lipstick lesbians, and devotees of such subcultural styles as punk. They rejected the "natural" as a measure of authenticity, and held instead to the view that cosmetics use could be a source of play, pleasure, and self-expression. Again, cosmetics companies have picked up on that attitude, marketing lipstick, eye makeup, and nail polish in unusual and extreme colors and such provocative names as Vamp and Juicy.

### Developments in the Early 2000s

Western cosmetics became widespread in the global economy in the second half of the twentieth century. Corporations like Unilever and Ponds established subsidiaries, contracted with local import firms, and sold beauty preparations in Latin America, the Middle East, Asia, and Africa. American manufacturers marketed cosmetics in a difficult balancing act, appealing to universal ideals of beauty, promoting the American style of actresses and models, and nodding to national and cultural differences. Avon's success in the international arena depended on native sales agents who understood local customs and concerns even as they projected the image of American beauty, lifestyles, and values. By the 1990s, "Avon calling" could be heard around the world, including post-communist and developing countries.

By the twenty-first century, cosmetics manufacturers had invested heavily in scientific research, working closely with chemists and dermatologists. These new "cosmeceuticals" went beyond the hypoallergenic products available since the 1930s and included creams and ointments containing such ingredients as Retin A, which

appears to reduce the effects of aging and improves the skin. These products have increasingly blurred the lines between cosmetics, drugs, and medical specialties. The post-World War II baby-boom generation has fueled the growth of anti-aging research and product development, a trend that is expected to continue.

An important development in cosmetics is the partially successful effort to sell cosmetics to men, beyond the traditional grooming products like aftershave and cologne. Both mass manufacturers and some high-end firms, including Helena Rubinstein, tried unsuccessfully to sell cosmetics to men earlier in the twentieth century. Since 1980, however, a significant number of urban professional men and gay men have begun to use moisturizer, exfoliating liquids, and even bronzers to improve their appearance. Although often similar to women's cosmetics, these products are usually segregated in a separate men's counter in retail stores and appear with different brand names and packaging. Young men in such music and dance subcultures as heavy metal and goth will often wear colorful makeup as performers and audience members. Most makeup remains so deeply associated with femininity and effeminacy, however, that very few men choose to use it in everyday business and social life, and those who do seek a "natural" look.

*See also Appearance; Cosmetics, Non-Western.*

#### BIBLIOGRAPHY

- Allen, Margaret. *Selling Dreams: Inside the Beauty Business*. New York: Simon and Schuster, 1981.
- Banner, Lois. *American Beauty*. Chicago: University of Chicago Press, 1983.
- De Castlebajac, Kate. *The Face of the Century: 100 Years of Makeup and Style*. New York: Rizzoli International, 1995.
- Gunn, Fenja. *The Artificial Face: A History of Cosmetics*. London: David and Charles, 1973.
- Koehn, Nancy. "Estee Lauder: Self-Definition and the Modern Cosmetics Market." In *Beauty and Business: Commerce, Gender, and Culture in Modern America*. Edited by Philip Scranton, 217–251. New York: Routledge, 2001.
- Manko, Katina L. "A Depression-Proof Business Strategy: The California Perfume Company's Motivational Literature." In *Beauty and Business: Commerce, Gender, and Culture in Modern America*. Edited by Philip Scranton, 142–168. New York: Routledge, 2001.
- Peiss, Kathy. *Hope in a Jar: The Making of America's Beauty Culture*. New York: Metropolitan Books, 1998.
- Smith, Virginia. "The Popularisation of Medical Knowledge: The Case of Cosmetics." *Society for the Social History of Medicine Bulletin* 36 (1986): 12–15.
- Vinikas, Vincent. *Soft Soap, Hard Sell: American Hygiene in an Age of Advertisement*. Ames: Iowa State University Press, 1992.
- Wolf, Naomi. *The Beauty Myth*. New York: William Morrow, 1991.

*Kathy Peiss*

**COSTUME DESIGNER** Costume design as a profession is a twentieth-century phenomenon. Until the end of the nineteenth century, costumes for popular entertainments were assembled piecemeal, either by the director, the actor-manager or by the patron. Repertory companies were the norm in the nineteenth century, and it made sense for a company to maintain a stock of costumes that could be used in multiple productions. Individual actors, working with more than one company, might travel with their own costumes—a practice that continues in the twenty-first century among opera singers.

Exceptions to the piecemeal approach include entertainments devised by artists during the Renaissance and the court masques designed by Inigo Jones in seventeenth-century England, but both are rare examples of a unified vision.

The end of the nineteenth century saw a shift from companies of actors performing a rotating repertoire of plays to stand-alone productions with actors hired specifically for each role. With actors moving from show to show, it didn't make economic sense for producers to maintain a large wardrobe inventory. Simultaneously, a heightened interest in realism called for specialists with the ability to reproduce accurately clothing of the past. Enter the designer.

#### The First Designers

An article in the *New Idea Women's Magazine* says that by 1906 theatrical costume design firms flourished in most major cities. Some, like Eaves or Van Horn's, in New York and Philadelphia respectively, began as manufacturers of uniforms or regalia and expanded into the theatrical market. By contrast, Mrs. Caroline Siedle and Mrs. Castel-Bert, both in New York, established their ateliers specifically to cater to the growing theater industry.

Producers hired these pioneering designers at their discretion. They were under no obligation to commit to the services of a designer and many preferred to rent existing costumes. For a modern dress show, leading actresses might commission their dressmaker, while minor players raided their closets. Two events changed that.

The actor's strike of 1919 put an end to the practice of performers providing their own wardrobes. Thereafter, producers were required by contract to supply costumes for everyone. Then, in 1923, the stage designers unionized. As part of the collective bargaining agreement, producers of Broadway and touring productions had to hire a union designer. The first union members were set designers who might also design costumes. By 1936 the union recognized costume designers as a separate specialty.

Film designers also emerged in the 1920s. At first, actresses in contemporary films wore their own clothes, "so ladies with good wardrobes found they got more jobs" (Chierichetti 1976, p. 8). For period films, producers rented costumes.



**Costumer designers at the Palais Garnier, Paris.** Once the concept for a particular production has been agreed upon, the costume designer researches the script and creates sketches of possible garments for each character. © ANNEBICQUE BERNARD/CORBIS. REPRODUCED BY PERMISSION.

The industry moved from New York to California in the 1920s and the studio system replaced the independently shot films of the teens. Designers emerged partly because studio heads wanted their films to have a cohesive look but primarily because the shift from black and white to color film, and from silents to talkies, required costumes especially designed for the medium. The early film distorted colors. Blue, on film, appeared white. Red photographed as black. The early microphones were so sensitive to sounds that only soft fabrics could be used. Crisp fabrics rustled, drowning out the dialogue. By the end of the 1920s, every studio had at least one house designer, a support staff of sketch artists and costumers, and a research department and library.

### The Process

The costume designer is responsible for the head-to-toe look of everyone who appears on stage or on screen. After reading the script, the designer meets with the director and others to debate their approach to the material. *Hamlet*, for example, has been set in medieval Denmark, in Vietnam, and in contemporary dress. All are valid approaches.

With the production concept agreed on, the designer has an interval for research. He or she develops color sketches for every costume worn in the show. Depending on the medium, a variety of people see and approve these sketches. In the theater, the director, producer, choreographer, and sometimes the star will have approval. For film, the costume designer works with the director, cinematographer, and art director in addition to the stars.

Once approved, the sketches go into the costume shop to be translated into three-dimensional garments. Many regional theater, opera, and ballet companies maintain their own costume shops. All university theater departments do so as well. For other venues, including Broadway and feature films, a range of independent theatrical costume shops submit bids for producing the costumes. Even when contemporary clothes are purchased or come from a rental house, fittings and alterations are performed by the costume shop.

### In the Shop

With the sketches in the shop, the costume designer and assistants essentially move in for the length of the build



time, which in theater equals the length of the rehearsal period, typically between three and five weeks. The practice differs for film and opera. In a university setting, the designers may do their own fabric and trim shopping. Elsewhere, costume shops have buyers whose job is to scour the market, bringing back swatches for the designer's consideration.

While the buyers are swatching, costume makers are creating custom-made patterns for each costume, which are then made up, usually in muslin. As each is completed, the actor who will wear it is called for the first of several fittings. An important function of the first fitting is to see that the actor can move well in a costume designed before rehearsals began. Once in rehearsal, the director or choreographer may decide that performing a somersault, despite the bustle gown, is integral to the show's concept. This is the designer's moment to learn that vital piece of information and to adapt the design to allow for the movement. For the 1972 Broadway production of *Pippin*, for example, director-choreographer Bob Fosse had insisted that the armor be rigid metal. When his designer, Patricia Zipprodt, saw what the dancers had to do, she realized that only something flexible would satisfy his needs.

At the first fitting, the designer also has a chance to see if the proportions of the garment suit the performer. At the second fitting, the costume has been made up in the actual fabric to be used. Custom underpinnings, shoes, and millinery are included so that both designer and performer can see the total look. At this fitting all the craftspeople have the opportunity to make adjustments that may increase the performer's comfort or that are requested by the designer.

The final fitting is in the completed costume with the expectation that no further work is necessary at this stage. The clothes move out of the shop and into the theater or onto location.

### In Performance

Film designers view daily rushes to see how well their costumes work on screen, while a live performance will have one or more dress rehearsals and a series of preview performances before the opening night. The designer attends them all. This is the time when all of the production elements—scenery, lighting, movement, and costumes come together and occasionally what seemed like a good idea in the shop does not work in performance. With an original script, new scenes or musical numbers may be added, requiring new costumes. The designer has only a few days to produce new designs, get them into the shop, select the fabrics, attend fittings, and see the new costumes integrated into the production. The designer's job is finished only when the show opens to the public or when the last scene is filmed.

See also **Ballet Costume; Dance Costume; Theatrical Costume; Theatrical Makeup.**

### BIBLIOGRAPHY

- Anderson, Cletus, and Barbara Anderson. *Costume Design*. New York: Holt, Rhinehart and Winston, 1984. A good overview of the process.
- Anderson, Norah. "Stage Dressmaking and Stage Dressmakers." *New Idea Women's Magazine* (November 1906): 12–16.
- Bentley, Toni. *Costumes by Karinska*. New York: Harry N. Abrams, 1995. Especially chapter 5 on the design and construction of costumes for the ballet.
- Chierichetti, David. *Hollywood Costume Design*. New York: Harmony Books, 1976. The introduction is good on the origins of film design.
- Ingham, Rosemary, and Liz Covey. *The Costume Designer's Handbook: A Complete Guide for Amateur and Professional Costume Designers*. Portsmouth, N.H.: Heineman, 1992. Excellent overview of the profession.
- Jones, Robert Edward. *The Dramatic Imagination*. New York: Theatre Arts, 1941. An inspirational classic, especially chapter 5, "Some Thoughts on Stage Costume."
- Pecktal, Lynn. *Costume Design: Techniques of Modern Masters*. New York: Backstage Books, 1993. Interviews with Broadway and feature film designers including training and working methods.

Whitney Blausen

**COSTUME JEWELRY** The earliest costume jewelry was simply an imitation of precious jewelry and had little intrinsic value or original style of its own. However, once the French couturiers put their names to costume jewelry it became desirable, acceptable, and expensive. In the early 1910s, couturier Paul Poiret became a proponent of costume jewelry, accessorizing his models with necklaces of silk tassels and semiprecious stones designed by the artist Iribe.

Coco Chanel, Jean Patou, Drécoll, and Premet were also among the first famous couturiers to create costume jewelry along with clothing, which propelled its acceptance. By 1925, the Marshall Field's department store catalog described costume jewelry in positive terms, announcing, "The imitation is no longer a disgrace."

The most ubiquitous jewelry imitation in the 1920s was a pearl necklace. Strands of pearls or colored beads neatly circled the neck or swung to waist, hip, even knee-length, made to move with fast-paced dances like the Charleston. At the end of the period when the little black dress became a daytime standard, shorter strands of light-colored beads and pearls continued as the accessories of choice. Rhinestone jewelry also blazed into prominence, as it was the perfect foil for two fashion innovations: sun-tans and white evening gowns.

Beginning in the 1920s and continuing throughout the 1930s, fashion and jewelry shared a multitude of influences including Art Deco, the Far East, North Africa, and India. Egyptian motifs were inspired by the discovery of Tutankhamen's tomb in 1922. The Colonial Ex-



During World War II, imports from Europe were cut off, and many jewelry materials were also restricted. Desperate costume jewelers bought beaded sweaters, evening dresses, and even stage costumes, and harvested their beads, rhinestones, and pearls. They also fashioned jewelry from humble materials that were readily available during wartime: pumpkin seeds, nuts, shells, olive pits, clay, leather, felt, yarn, and even upholstery fabrics. Women wore hand-carved wooden brooches, necklaces of multicolored painted shells, cork, and bits of driftwood. There was little difference between quirky, childish, commercially made jewelry and what the women made themselves following do-it-yourself instructions published in magazines.

Patriotic motifs flourished during wartime, ranging from red, white, and blue to all-American motifs related to California, Hawaii, Native American Indians, and cowboys. Costume jewelry also took on a militaristic theme, and miniature model tanks, airplanes, battleships, jeeps, soldiers, and even hand grenades were made up in metal or wood and worn as brooches, necklaces, and earrings. In the summer of 1940, “V” for victory was a popular design. As Mexico was America’s wartime ally, jewelry imported from that country and its imitations was highly fashionable. Two notable Mexican artisans who worked in silver, Rebajes and Spratling, had their sophisticated jewelry featured at top department stores across the country. Patriotic jewelry completely vanished during peacetime.

Postwar fashion succumbed to couturier Christian Dior’s highly structured New Look, followed by a series of equally severe styles: the chemise, sheathe, trapeze, and sack dress. The transformation was radical. Clothing concealed most of a woman’s body, and only chokers, earrings, bracelets (notably charm bracelets), and brooches were visible. Dresses and suits in heavy, rough-textured fabrics were weighty enough to support the hunky, oversized circles, ovals, snowflake, or starburst-shaped brooches (associated with the atomic bomb), typically three-dimensional. Rhinestones were standard, produced in a rainbow of colors including white, black, pink, blue, yellow, and iridescent, which was an innovation.

Tailored jewelry was the most conservative accessory in the 1950s. Neat and small scale, it was made up in gold or silver metal with little ornamentation. Although clothing concealed their figures, women wore their hair up-swept, in a ponytail, or cropped gamine short, to show off hoop, button, and neat pearl earrings. Later in the decade, metal jewelry was thicker, its surface scored, chiseled, or deeply etched, a treatment that lingered into the 1960s.

The distinction between accessories for day and night blurred as casual Italian sportswear became popular. For example, in 1959 actress Elizabeth Taylor was featured in *Life* magazine wearing Dior’s black jet choker with a low-cut black sweater. Entertaining at home also created another new fashion category. Theatrical, over-

sized chandelier and girandole earrings complemented lounging pajamas, caftans, and floor-length skirts, which remained stylish hostess garb into the 1960s.

Chanel plundered the Renaissance for jewelry inspiration. With her signature suits, in 1957 she showed pendants (notably the Maltese cross), brooches, and chain sautoirs in heavy gold set with baroque pearls, lumpy glass rubies, and emeralds. This style still continues to be identified with Chanel today.

In the 1960s, bold, pop-art graphic “flower power” motifs were fashion favorites. The ubiquitous daisy was produced in every material from plastic to enameled metal, and in a palette of neon bright colors. Daisies were linked into belts, pinned on hats and dresses, and suspended from chains around the neck. Even Chanel and Dior produced flower jewelry, although their brooches, necklaces, and earrings were petaled with fragile poured glass.

Hippies and the counterculture rejected this sophistication in favor of handmade and ethnic jewelry in humble materials: clay and glass beads, yarn, temple bells, papier-mâché, macramé, and feathers. Both men and women pierced their ears, crafted their own headbands, ornamented their clothing with beads and embroidery, strung love beads, or hung a peace sign, ankh, or zodiac symbol on a strip of rawhide around their necks. Singer Janis Joplin typically performed while weighed down with a massive assortment of new and vintage necklaces and bracelets.

*Vogue* and *Harper’s Bazaar* also cultivated this theatrical style. Diana Vreeland, editor-in-chief of *Vogue*, commissioned wildly dramatic, oversized jewelry specifically for the magazine. Usually one of a kind, tenuously held together with wire, thread, and glue, these pieces were too fragile to be worn outside the photo studio. There were breastplates of rhinestones or tiny mirrors, golf-ball-size pearl rings, shoulder-sweeping feather earrings, wrist and armloads of painted papier-mâché bracelets.

Technology also contributed to this fantastical mode. In 1965, plastic pearls were produced for the first time in lightweight, gigantic sizes. They were strung together into multistrand necklaces, bibs, helmets, and even dresses.

Style-wise, costume jewelry was a match for fine jewelry. The so-called beautiful people gleefully mixed costume jeweler Kenneth Jay Lane’s \$30 rhinestone and enamel panther bracelets (inspired by the Duchess of Windsor’s original Cartier models) with their real ones. Lane was well known for his weighty pendant necklaces, shoulder-length chandelier earrings set with gaudy, multicolored fake stones, and enormous cocktail rings. His clients ranged from Babe Paley to Greta Garbo and the Velvet Underground.

Chanel continued to produce Renaissance-style jewelry, notably Maltese crosses and cuff bracelets embellished with large stones, which morphed into a more exaggerated version. Diana Vreeland chose this style as



her signature, sporting a pair of bejeweled enamel cuffs reportedly designed by Fulco di Verdura.

At the end of the 1960s and into the 1970s, “space age” style was an alternative to this ornate jewelry. Coolly modern, geometric, it was made up in industrial materials such as transparent plastic and metal hardware. This hard-edged jewelry was a match for clothing ornamented with oversized buckles, zippers, grommets, and nail heads.

Around the same time, punk ruled the streets. The devotees of this style favored leather jackets and jeans that were as aggressive and unisex as their accessories: dog collars and leather armbands bristling with nail heads and spikes, thick chains worn as chokers and around waists. The most notorious punk ornamentation was also the simplest: a safety pin stuck through an ear, nose, lip, or cheek.

Two designers, Elsa Peretti and Robert Lee Morris, heavily influenced costume jewelry during this period. Peretti began designing for Tiffany in 1974, and costume jewelers immediately copied her small-scale, streamlined “lima bean” and “teardrop” pendants, and “diamonds by the yard” of cut stones strung on slender chains.

In New York City, Robert Lee Morris set up his own boutique, Artwear, as a showcase for his handmade gold-bead necklaces, gladiator-size cuffs, metal breastplates, and hefty belt buckles. Fashion designer Donna Karan accessorized her line with Morris’s bold and simple creations for several seasons.

In the 1980s, entertainers Cyndi Lauper and Madonna were the female forces that drove style through the new media of music videos, and both mixed lingerie with vintage clothing, and vintage jewelry with cheap new baubles. Madonna wore armloads of rubber bracelets with religious-cross pendants and rosaries. Hip hop and rap music stars sported jewelry in heavy gold or gold-plated look-alikes: nameplate pendants, knuckle rings, ID bracelets. A gold-covered front tooth was a more permanent and extreme ornament.

As the simplified styles of designers Giorgio Armani and Calvin Klein became popular, jewelry gradually shrank in scale until it disappeared. As minimalism ruled fashion, the jewelry business was abysmal. However, costume jewelry came back to glitzy glory in the early 1990s, propelled by the whimsical accessories of Christian Lacroix and Karl Lagerfeld at Chanel. Lagerfeld successfully revived and restyled many of Chanel’s signatures, including multistrand pearl necklaces, and Renaissance-style jewelry. He used the “CC” logo as decoration on everything from earrings to pocketbooks.

Entertainers and movie stars steered fashion in 2000, and they wore the real thing, not costume jewelry. Pop music figures Jennifer Lopez and Lil’ Kim flashed enormous precious stones on their fingers. Impresario Sean Combs (a.k.a Puff Daddy, P. Diddy) flaunted enormous diamond-stud earrings and monster diamond rings. A long line of movie stars, including Nicole Kidman and



**Coco Chanel, late 1930s.** By the 1930s, costume jewelry embraced bold designs and different influences of styles and cultures, becoming highly fashionable due in part to the influence of style icons such as Coco Chanel. Here Chanel models a sophisticated costume necklace. PHOTO COURTESY OF JODY SHIELDS. REPRODUCED BY PERMISSION.

Charlize Theron, borrowed jewelry, usually fine antique pieces, from established jewelers such as Harry Winston and Fred Leighton. It was a sign of the times when Chanel launched a line of precious jewelry, and Prada installed precious jewelry from Fred Leighton in their Soho store. Once again, the cycle had turned, and costume jewelry imitated precious jewelry, or “bling bling” as the blinding real thing was called in 2003.

*See also* **Bracelets; Brooches and Pins; Earrings; Jewelry; Necklaces and Pendants.**

#### BIBLIOGRAPHY

- Becker, Vivienne. *Fabulous Fakes: The History of Fantasy and Fashion Jewellery*. London: Grafton, 1988.
- Davidov, Corinne. *The Bakelite Jewelry Book*. New York: Abbeville Press, 1988.
- Mulvah, Jane. *Costume Jewelry in Vogue*. London: Thames and Hudson, Inc., 1988.
- Nadelhoffer, Hans. *Cartier Jewelers Extraordinary*. New York: Harry N. Abrams, 1984.

Shields, Jody. *All That Glitters: The Glory of Costume Jewelry*. New York: Rizzoli, 1987

Jody Shields

**COTTON** Cotton plants are native to several parts of the world, and the use of cotton fiber originated independently at least 7,000 years ago in both the India/Pakistan and the Mexico/Peru regions. One of the oldest extant cotton textiles dates to about 3000 B.C.E. Because cotton plants cannot be grown in cooler locales such as northern Europe, climate was an important limiting factor in the spread of cotton cultivation.

Cotton textiles were traded widely in Roman times, and the growing and production of cotton soon spread from India to Egypt and China. Cotton production did not begin in Greece until C.E. 200 or in Spain until tenth century C.E. By the thirteenth century, though, Barcelona was a thriving cotton industry center specializing in producing cotton canvas for sails. England began using imported cotton in the thirteenth century. Widespread use began in the seventeenth century when significant quantities of raw fiber began to be imported to Great Britain from the expanding British colonies for processing and weaving into cloth.

Cotton textiles were widely used in pre-Columbian Meso-American and Andean civilizations. With the beginning of European colonization of the Americas, cotton originating in Mexico and Peru began to be cultivated wherever climate and soil were suitable. Cotton became an established crop in many parts of the American South, and later spread into the regions now known as Texas, Arizona, and California.

Cotton also became an important global trade commodity. For example, England exchanged American cotton fiber for Indian and Egyptian cotton textiles. Among these trade goods, the finest cotton textiles were from long, fine staple cotton fiber. In fact, Indian prints and gauze cottons surpassed the popularity of fine woolens in the seventeenth century and played a role in greatly diminishing the demand for wool and tapestry textiles.

The cotton trade figured in the American War for Independence, as the British struggled to hold onto their source of raw fiber. Cotton production also played a controversial role in the slave trade; cotton, produced by slaves in America, was among the trade goods used to obtain other slaves in Africa. The emphasis on hand labor in cotton production increased the demand for slave labor at the same time that slave labor became ethically intolerable to many Americans (Parker 1998). The plantation system that was at the heart of cotton production thus was an issue in the controversies and regional disputes that led to the American Civil War.

With the invention of the cotton gin in 1793, cotton became a much higher volume commodity, as the

machine took over one of the most laborious steps in cotton production, the separation of fibers from seeds. The cotton gin thus was a key component in the development of the U.S. textile and apparel industry. By 1859, two-thirds of the world production of cotton fiber came from the United States (Parker 1998).

Meanwhile, immigrants from Europe brought with them the knowledge and the technology to establish textile production in the United States. Using available water power to drive spinning and weaving machinery, New England became the center of the early textile industry. During the Civil War, a severe reduction in cotton fiber available from the American South led the British industry to seek other sources for cotton fiber and thus expanded cotton production globally. In the United States, both the production of cotton fiber and its processing into cloth continued to evolve according to changing economic circumstances. Between World Wars I and II, a majority of the U.S. textile mills relocated from the Northeast to the South and fiber production expanded in Texas and California.

At the beginning of the twentieth century, cotton production was led by China, the United States, Russia, India, Pakistan, Brazil, and Turkey. Cotton fiber had become an important economic force in as many as eighty countries worldwide. Cotton remains the most important fiber in apparel with nearly half of the world demand for apparel fibers traceable to cotton and cotton blends.

### Processing Cotton Fiber

Cotton fiber is a seed hair removed from the boll (seed pod) of the cotton plant that bursts open when fully developed. Bolls emerge from blossoms that fall off to leave the exposed boll. One boll can produce more than 250,000 individual fibers. The cotton plant is a four- to six-foot tall shrubby annual in temperate climates, but a treelike perennial in tropical climates. The best qualities of cotton grow in climates with high rainfall in the growing season and a dry, warm picking season. Very warm, dry climates in which irrigation substitutes for rainfall, such as Arizona and Uzbekistan, are also well suited to cotton production. Rain or strong wind can cause damage to opened bolls. Cotton is subject to damage from the boll weevil, bollworm, and other insects as well as several diseases. Application of insecticides and development of disease-resistant varieties have helped achieve production goals for cotton. Recent innovations in organic cotton and genetically colored cottons continue the progression of putting science into the production process.

Processing cotton includes many stages. While *picking* mature cotton bolls by hand yields the highest quality, mechanized picking makes high production more feasible and affordable. In many countries where hand labor is more affordable than equipment, cotton continues to be hand-picked. *Ginning* is used to clean debris from cotton and prepare it for spinning into yarn. *Grading* separates cotton into quality levels in which short fibers tend



**Genetically modified cotton in India.** Recent scientific advancements have made it possible for genes to be injected into growing cotton. These genes target the main pests that feed on the plant without harming beneficial insects. © PALLAVA BAGLA/CORBIS. REPRODUCED BY PERMISSION.

to correspond to coarse and long fibers to make very fine quality textiles. *Carding* is the next step in all cotton fiber processing and is used to further clean and minimally align fibers. An additional processing called *combing* is used to further clean and align higher quality cottons. Yarn creation involves *drawing* fibers into a thinner strand that is then *spun* into a finished yarn ready for fabrication into the textile. So-called greige-good (unfinished) fabrics undergo final finishing, which typically involves *singing* (burning off loose particles) and then *tentering* to align the grain of the fabric and adjust the width. Either at the fiber, yarn, fabric, or product stage, cotton may be subject to *bleaching* to remove natural colors (tan through gray) at which point fashionable colors can be added through *dyeing* and *printing* processes. Other final *finishing* processes might be used to obtain special features such as *sizing* for smoothness; durable press; a polished surface; or a puckered surface texture.

#### Characteristics of Cotton Textiles

Cotton fiber varies in length from as little as 1/8-inch linters that are not useable as fiber up to ultrafine long sta-

ple cottons of 2½ inches. Short staple fibers (3/4–1 inch) are used for relatively coarse textiles like bagging; medium to long staple (1–1¾ inches) are the Upland cottons used for a majority of cotton products; and extra long staple (1¾–2½ inches) cottons labeled as *Egyptian*, *pima*, *Supima*, *sea island*, and *Peruvian* cottons are used for very high quality exclusive cotton goods. Many are hand picked to achieve top quality. Natural colors for cotton fibers include off-white, cream, and gray; selective breeding of naturally colored cottons has expanded the color range to include brown, rust, red, beige, and green. Higher quality, long staple cottons are closer to white than coarse shorter fibers. But regardless of natural color, bleaching is required to produce white or pure colors.

Cotton fiber is a flat, twisted, ribbon-like structure easily identified under the microscope. This characteristic can be somewhat modified by finishing fiber or fabric with sodium hydroxide (caustic soda) or liquid ammonia and thereby swelling the fiber. This rounder mercerized or ammoniated fiber is more lustrous and stronger than typical cotton. It also accepts dye better than untreated cotton. Applying this treatment in a pattern yields plissé,



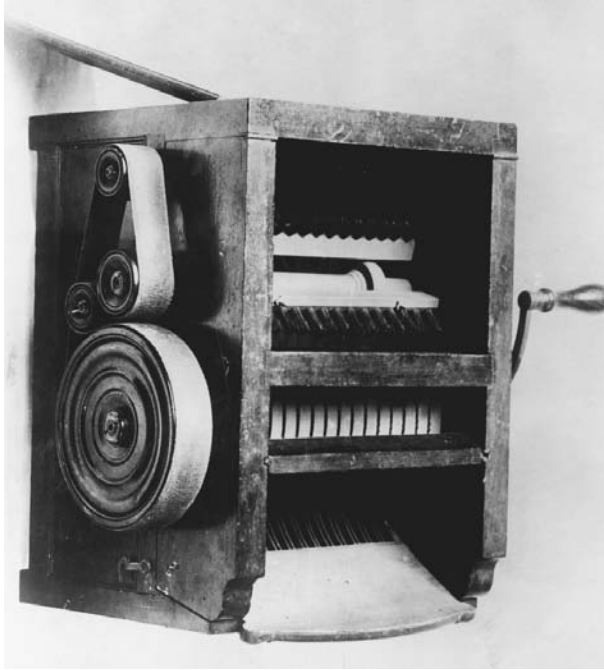

**Cotton gin.** The 1793 invention of the cotton gin by Eli Whitney helped revolutionize the United States's textile industry and bolstered the value of cotton as a commodity. © UNDERWOOD & UNDERWOOD/CORBIS. REPRODUCED BY PERMISSION.

a puckered textured surface effect quite unlike the typical cotton fabric surface, which is flat, slightly wrinkled, and somewhat dull. Long-staple fine cottons exceed this standard and are often hard to differentiate from silk in surface smoothness. Cotton tends to be neutral on the skin, so is considered a comfortable fiber for everyday wear.

Cotton is cellulosic and thus has aesthetic, comfort, and performance characteristics reminiscent of linen and rayon textiles. These include high absorbency and low insulation and a tendency to be cool in hot temperatures. Cotton does not dry as quickly as linen and silk. As a relatively heavy textile, cotton is more useful for keeping cool or for dressing in layers than it is in providing warmth. Cotton is subject to linting, that is, the shedding of fibers that can result in bits of fiber lying on the surface of the textile. Cotton is also somewhat subject to abrasion and will become thin or develop holes in areas of recurring abrasion. Highly bleached cotton textiles have lower strength and durability than those that retain natural color. Cotton fibers resist absorbing dyes and fade easily in sunlight and from abrasion. Therefore the “faded” effect commonly found among fashionable cotton fabrics since the 1970s optimizes cotton’s natural character.

Cotton is a medium strong fiber with a tendency to wrinkle. Wrinkling is diminished when fibers are long and fine and yarns are flexible. Wrinkle resistant finishes

can help overcome lack of resiliency. Blending cotton with synthetic fibers such as polyester is the most common way to overcome wrinkling. This solution without careful attention to yarn quality can lead to pilling as short cotton fibers break off and synthetic fibers hold onto the broken fibers.

The twisted cotton fiber results naturally in a somewhat fuzzy spun yarn that holds onto dirt particles. Water- and oil-borne staining is also commonplace due to high absorbency. Cotton has high heat resistance, is stronger wet than dry, and withstands cleaning, pressing, and creasing very successfully. Cotton is resistant to most cleaning detergents but damaged by acid such as air pollutants. Cotton shrinks back to original dimensions when wet and thus experiences relaxation shrinkage. Because it can be sterilized by boiling, cotton is useful in clean room and medical applications. Cotton seldom irritates the skin or causes allergies. Cotton textiles are flammable and subject to damage by mildew, perspiration, bleach, and silverfish.

### Cotton in Fashion across Time

Cotton holds a unique place in history, evolving from being more highly valued than silk and wool in the sixteenth and seventeenth centuries to becoming an everyday, comfort-oriented textile in contemporary apparel worldwide. Early Indian cottons were so ultra-fine that they were extremely valuable as trade goods and were highly competitive with fine woolen and silk textiles of the era. Cotton was originally available only to the wealthy due to the intensive hand labor needed to process fiber into yarns. In the early nineteenth century, wool held nearly 80 percent of world market share, with cotton and linen taking second and third place. However, by the early twentieth century, cotton became and remains in the early 2000s the leading apparel fiber worldwide. Liberty cottons are an example of the continued success of cotton as a prestige fabric; they have remained a trademark for the very finest Egyptian long staple cottons since 1875 when Liberty of London began copying Indian cotton prints onto ultra-fine long staple cottons. The advent of synthetic fibers proved strong competition for cotton in the 1970s, but cotton production rebounded as comfort became more important to many consumers than price. Faded cotton is an example of the power of the “comfort” aesthetic. Every decade since the 1970s has returned faded cotton to current fashion. While synthetic fibers can achieve the aesthetics of cotton, they only very recently came close to both the feel and the comfort of cotton with the advent of microfiber polyester. The widespread adoption of “casual Friday” dress codes by much of corporate America in the 1990s continued to make cotton an important element in the fashion aesthetic. Cotton has also achieved a good reputation as a “green” textile, because it is biodegradable.

### Common Cotton Textile Uses

Cotton is highly valued for comfort and launderability. It is highly tolerant of heavy use. Worldwide, approximately 50 percent of apparel is made of cotton fiber, but pure cotton products are not as prevalent as cotton blends. In apparel, 100 percent cotton cloth is preferred for uses that demand being next to the skin or high physical activity. This includes a wide range of activewear that focuses on jersey, interlock, and sweatshirt knitwear for the upper body and woven textiles such as denim and khaki for the lower body. Apparel for situations where appearance is more important than comfort in physical activity is frequently made from cotton blends.

About 60 percent of all interior textiles (excluding floor coverings) are made of cotton or cotton blends; this category includes sheets, towels, blankets, draperies, curtains, upholstery, slipcovers, rugs, and wall coverings. In many of these applications, cotton's natural character is aesthetically pleasing, but performance characteristics such as high absorbency and tendency to soil are not advantageous. Manufacturers combat this tendency with stain-resistant finishes and often try to achieve the aesthetic qualities of cotton in cotton-synthetic blends.

Industrial uses account for less than 10 percent of cotton production, reflecting the advantages of synthetics for industrial applications requiring strength and durability. Cotton is preferred for many medical uses because it can easily be sterilized, is highly absorbent, and does not retain static electricity.

See also **Fibers; Textiles and International Trade.**

### BIBLIOGRAPHY

- Collier, B., and P. Tortora. *Understanding Textiles*. New York: Macmillan Publishing, 2000.
- Hatch, K. *Textile Science*. Minneapolis, Minn.: West Publishing, 1993.
- Kadolph, S., and A. Langford. *Textiles*. 9th ed. New York: Prentice-Hall, 2002.
- Parker, J. *All about Cotton*. Seattle, Wash.: Rain City Publishing, 1998.

Carol J. Salusso

**COURRÈGES, ANDRÉ** André Courrèges (1923– ) was born in Pau, in the Basque part of France. He studied engineering before pursuing a career in fashion. Courrèges worked first under the illustrious couturier Cristóbal Balenciaga from 1950 until 1961, when he left to open his own house. Balenciaga, whose clients were primarily mature and conservative women of wealth, was paradoxically often years ahead of his time. He produced sculptured garments that served as architecture for the woman's body, and it was from Balenciaga that Courrèges learned a highly disciplined yet innovative approach to design.

### Early Career

The London "youthquake" of the early 1960s produced experiments in fashion that glorified young people and sent shock waves all the way to Paris, the capital of haute couture. André Courrèges's success was based on his ability to revitalize and preserve high fashion by injecting elements of the youthquake into haute couture. Along with London-based Mary Quant, Courrèges was a leading figure in the introduction of the miniskirt—the article of clothing most closely associated with youthfulness in its disavowal of traditional social codes and the rules of fashion. The miniskirt offered minimal coverage of the lower body, the better to flaunt the young legs that became so visible in the 1960s. Gone were the days of ladylike propriety, now banished by the emphasis on youth.

Although opinion is divided as to who actually "invented" the miniskirt, Quant or Courrèges, it is generally accepted that Mary Quant was first, although only after "the girls on the street." Courrèges initially showed his miniskirts in the early 1960s, followed by futurist-inspired pantsuits, coats, hats, and his trademark white kid boots. *British Vogue* declared 1964 "the year of Courrèges" (Howell, p. 284). The spring-summer collection of 1964 represented a couture version of youth-oriented styles with the invention of the "moon girl" look; the collection ultimately secured for Courrèges the title the designer of the Space Age.

### Courrèges's Space Age Design

Courrèges's 1964 Space Age collection unveiled, among other pieces, architecturally-sculpted, double-breasted coats with contrasting trim, well-tailored, sleeveless or short-sleeved minidresses with dropped waistlines and detailed welt seaming, and tunics worn with hipster pants. Vivid shades of pink, orange, green, and navy complemented the designer's bold repeated use of white and silver. Accessories for each ensemble included oversized, white, tennis-ball sunglasses or goggles with narrow eye slits, gloves, helmet-shaped hats and other hats recalling baby bonnets, and square-toed midcalf boots made of soft, white kid leather. Perhaps his most famous contribution to fashion after the miniskirt itself was the "Courrèges boot," originally designed in 1963. The entire 1964 spring collection was a phenomenal success and influenced other designers such as Pierre Cardin and Paco Rabanne to create their own versions of futuristic fashion. It also led ready-to-wear manufacturers, hoping to rake in huge profits, to copy and mass-produce similar designs.

Courrèges's visionary approach to fashion made use of clean geometrical lines and rejected superfluous material. He employed a minimal amount of decorative ornamentation; when he used it at all, it was most often his trademark daisy motif, chosen for its symbolic association with youth. The couturier's love of sharp lines and the angular crispness of his forms reflected his background in engineering. Courrèges's clothing not only

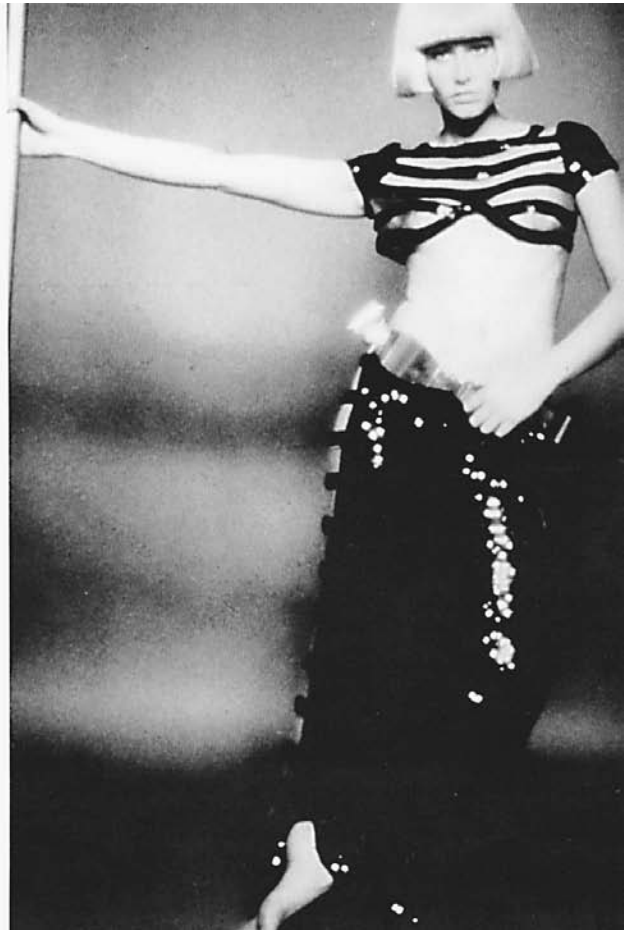
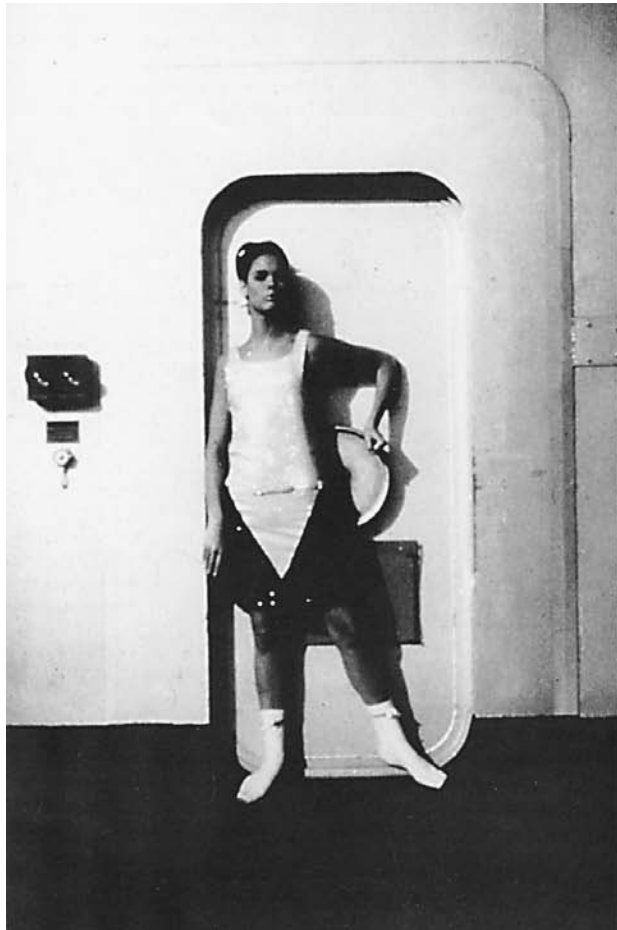

**Andre Courrèges designs.** Two outfits illustrate Courrèges's preference for streamlined shapes and dramatic use of the color white.  
DESIGN BY ANDRÉ COURRÈGES, 1963, PHOTOGRAPH. COURRÈGES DESIGN.

emphasized technologically advanced synthetic materials that were evocative of the times, but also pushed fashion further into the future by situating it within modern life. This intellectual component, typical of Parisian design, carried over into Courrèges's work at his studio on the avenue Kléber, where he dressed luminaries from the duchess of Windsor to Jacqueline Kennedy, Lee Radziwill, and Jane Holzer. The "white" salon, as the studio was known, personified the designer's ideals of functionality and practicality with its modern minimalist decor. André Courrèges created modern clothes for modern women living in modern times.

Courrèges's first official couture collection made its debut in 1965; two years later Prototype, the made-to-order custom line, was introduced. The introduction of luxury prêt-à-porter with Couture Future at the end of the decade marked Courrèges's transition into the 1970s. The new decade saw the establishment of the designer's first fragrance, Empreinte, in 1970 along with a men's ready-to-wear line in 1973. The need to reach a mass-market audience brought with it the lower-priced Hy-

perbole line in the early 1980s, and the desire to solidify a world-renowned brand name through profitable licensing arrangements led to the sale of the company in 1985 to the Japanese firm Itokin.

### Courrèges's Legacy

Along with his contemporaries Paco Rabanne and Pierre Cardin, André Courrèges helped to create an unmistakable style that defined an era. His lasting impact on fashion design was his astute recognition of the revolution launched by the younger generation. The explosion of the "youthquake" onto the scene fundamentally altered the direction of fashion in the 1960s. Fashion now not only celebrated the present but also looked forward to the future. The future was conceivably Courrèges's greatest muse, and the infinite possibilities of tomorrow stimulated his experiments with form.

The mod revival spearheaded in the early 1990s by Miuccia Prada recalled the design principles and iconic looks pioneered by Courrèges three decades earlier.





**André Courrèges with model.** Courrèges made his mark during the 1960s by capitalizing on his ability to inject high fashion with a dose of bold, youthful energy. © RICHARD MELLOUL/CORBIS SYGMA. REPRODUCED BY PERMISSION.

From white, A-line minishirt dresses to nylon microfiber accessories, Prada's continual search for innovation is influenced by Courrèges's designs from the 1960s. Furthermore, the fall 2003 collections represented a direct backward glance at youthquake fashion. Designs that evoked the Space Age appeared on catwalks from New York to Paris. White and metallic "lunar" shades with occasional splashes of bright color dominated the palette. Geometrical lines were everywhere. The miniskirt reappeared in full force at Chanel, Marc Jacobs, and Donna Karan, while midcalf leather boots accessorized mod ensembles at Moschino and Tommy Hilfiger. The focus on youth, the contemporary use of architecturally shaped minimalist designs in bold contrasting colors, and the deliberate application of detailing demonstrates the lasting impact of 1960s fashion. Henceforth, every retro mod fashion will forever be traced back to the work of André Courrèges.

See also **Balenciaga, Cristóbal; Cardin, Pierre; High-Tech Fashion; Miniskirt; Prada; Quant, Mary; Rabanne, Paco; Space Age Styles; Techno-Textiles; Youthquake Fashions.**

#### BIBLIOGRAPHY

- "Balenciaga's Secret." *Women's Wear Daily*, 23 April 1961.
- Braddock, Sarah E., and Marie O'Mahony. *Techno Textiles: Revolutionary Fabrics for Fashion and Design*. New York: Thames and Hudson, Inc., 1998.
- "Eyeview." *Vogue* (October 1964): 87–89.
- Giraud, Françoise. "After Courrèges, What Future for the Haute Couture?" *New York Times Magazine* (12 September 1965): 50–51.
- Howell, Georgina. *In Vogue: Six Decades of Fashion*. London: Allen Lane, 1975.
- Koski, Lorna. "Courrèges: 60s Encore." *Women's Wear Daily* (26 October 1984).
- McDowell, Colin. *Fashion Today*. London: Phaidon Press Ltd., 2000.
- Nonkin, Lesly. "Courrèges: Shops Stay in Touch with Customer." *Women's Wear Daily* (12 September 1979).
- Sheppard, Eugenia. "Courrèges Back in Action." *World Journal Tribune* (19 March 1967): 8–11.
- Steele, Valerie. *Fifty Years of Fashion: New Look to Now*. New Haven, Conn.: Yale University Press, 1997.

Jennifer Park

**COURT DRESS** In the increasingly informal society of the early 2000s, in which many social barriers have broken down, it is arresting to read of the rigid code of manners that once determined who was, and who was not, eligible to be received at court, and who was, or was not, therefore part of “Good Society.” In Europe, by the seventeenth century, wearing the correct dress on this occasion was quite as important as having the right background.

Within a royal household, officers were appointed to supervise aspects of royal life. The officer, often called a lord chamberlain, who had charge of public and ceremonial events, would usually oversee the regulation of dress and matters of etiquette. By the nineteenth century, as the categories of people eligible for court presentation increased, and the styles of court dress became ever more various and complex, all earlier printed dress instructions were drawn together and published as formal regulations. In Great Britain, “Dress Worn at Court,” first published in 1882, was updated and reissued at about five-yearly intervals until 1937. Subsequently, hand-lists have been provided to specific individuals within the Royal Household, Foreign Office, Parliament, and Law Courts where the wearing of court dress may survive.

Until the late eighteenth century, in many European countries, many offices and titles remained as the personal gift of the monarch and members of his family. Both politicians and merchants found it essential to demonstrate to potential supporters that they enjoyed the favor of the court, to see their projects succeed. Even as the political importance of the court began to wane, there was always social advantage to be gained and special efforts continued to be made within the royal household to regulate the numbers and social standing of those attending. It was necessary for any new aspiring attendee to locate someone who had already been presented, to serve as his or her sponsor. In seventeenth-century France, a set of rules called “les honneurs de la cour” were drawn up. A French lady craving admittance had to prove a title of nobility extending back to 1400. Since the eighteenth century, there is evidence that this system could be abused: court officials could be bribed to gain admittance, the services of a sponsor could be bought, and sometimes the monarch himself would override the rules allowing a person of humble birth to attend as “une faveur de choix.”

The Spanish court was the earliest to actively promote a distinctive court dress from the sixteenth century. All courtiers, state officials, and those attending court had to wear a doublet and close-fitting knee breeches, made of silk or wool in a somber color, worn with the stiff “gorilla” collar of white linen. Eventually, the practice was adopted throughout the Spanish Empire, in Austria, and certain Catholic German states.

By the mid-seventeenth century, Louis XIV was concerned with promoting himself, the prestige of the

French court, French fashion, and culture. In 1661 he devised a system whereby fifty of his closest friends and supporters were allocated by special warrant a specific court dress. It was composed of a blue coat called a “justaucorps a brevet,” lined with red and trimmed with gold and silver galloon (braided trimming with scalloped edges), to a degree not allowed within earlier sumptuary legislation. The outfit was completed with a waistcoat, knee breeches, red-heeled shoes, and a sword. When the dauphin reached his majority, a brown coat similarly embellished was devised as the regulation dress for his household.

In about 1670, Louis XIV, perhaps with his brother, Philippe, duc d’Orleans and his wife, established the “grand habit” as a court dress for women. This dress had a stiff-boned bodice with a low, round neckline and cap sleeves trimmed with tiers of ruffles called “engageantes.” The skirt was cut full, and pulled back to reveal the petticoat worn beneath. This was often richly decorated. For their first presentation to the French king the “grand habit” had to be black. Subsequently, colored dresses could be worn. By about 1730 the petticoat was worn supported on large side hoops. A train replaced the skirt.

French court dress was adopted with small variations as court dress throughout Europe. By 1700 it had even become the regulation dress at the Spanish court for all but the most formal occasions.

In Great Britain the “grand habit” or “stiff bodied gown” was worn by members of the royal family and their immediate circle for royal weddings and coronations. However, by about 1700, the mantua was the customary dress worn by ladies attending court. It had an unboned bodice and full skirt. The neckline was cut square, and the bodice was closed in front with a separate stomacher. The elbow-length sleeves were finished with tiers of ruffles. The skirt was lifted back to reveal a petticoat worn beneath and by about 1750 served as little more than a train. By 1730 the petticoat was supported with large side hoops.

Ladies attending court in 1750 were generally wearing ostrich feathers as a hair ornament, and in 1762 Horace Walpole notes that they were considered “de rigueur.” Lace lappets had also emerged as the enduring trimming.

Men’s court dress in Great Britain was also simpler than its French counterpart, comprising a coat, waistcoat, and knee breeches, often made of fine silks and velvet, and frequently lavishly embellished with embroidery.

The “grand habit” saw its demise in 1789 with the French Revolution. However, by 1804 a new official dress had been devised by Jean-Baptiste Isabey for French government officials, as well as Napoleon, his family, and inner circle. For ladies a court train alone was retained, worn over fashionable evening dress.

The second half of the eighteenth century had seen many European courts beginning to devise special uniform liveries to be worn by members of the royal family and royal circle. In France, Louis XV established a green and gold costume as “uniforme des petits chateaux.” In 1734 Frederick, Prince of Wales in Great Britain, had devised a blue and buff uniform. His son George III in 1778 was responsible for the introduction of the Windsor uniform with its blue coat and distinctive red facings. It was also in 1778 that Gustavus III of Sweden put together a comprehensive order of court uniforms not only for his family and household, but also encompassing government officials, military officers, legal officials, and even university staff and students. They were of a consciously archaic style having its origin in seventeenth-century fashion, a period associated with Swedish greatness. Small variations in materials and ornament served to differentiate classes of officials. A court dress was also devised for Swedish ladies on similar lines. It was generally black and had a low round neckline trimmed with lace, and distinctive white puffed sleeves trimmed with a lattice of black ribbon.

Isabey's new system of official dress in France included uniforms for almost every office. By 1815 a similar program had been devised in Great Britain, the uniforms based on a pattern used by the French Army. This had a blue coat, embroidered with gold, worn with white knee breeches, silk stockings, flat pumps, a “chapeau bras” and a court sword. As the century progressed, more uniforms were added as new classes of officials were drawn into the system. Typically a uniform would be fashionable at the date of its introduction, but was rarely updated as the years passed. The embroidery would include motifs associated with the nation concerned or those, such as laurel or oak, traditionally associated with valor and steadfastness.

In early nineteenth-century Britain, the cloth court dress, worn by men for whom no uniform was prescribed, maintains the link with eighteenth-century custom. This was replaced in 1869 by “Velvet Court Dress” cut on very similar lines. While a more fashionable option was devised in the 1890s, this style of dress may still be seen worn in the early 2000s.

The French Revolution had comparatively little impact on women's court dress in Great Britain. The mantua continued to be worn, supported with an immense court hoop until 1820 when George IV suggested it should be abandoned. After this date court trains were worn over fashionable evening dress, with ostrich feather headdresses and lace lappets. By 1867 lace lappets were proving increasingly difficult to obtain, and the lord chamberlain permitted the wearing of two silk net streamers instead. In 1912, the lord chamberlain established that the streamers should be no more than forty-five inches long. The great profusion of ostrich feathers included in court headdresses of the early nineteenth cen-

ture had been reduced to two or three by mid century. In the dress regulations published in 1912, it is noted that there should be three feathers worn after the manner of the Prince of Wales's crest toward the left side of the head. In 1922 the lord chamberlain ordained that the court train was restricted to eighteen inches from the heels of the wearer. The color of ladies' court dress was not prescribed, but it became the convention that the dresses were of a pale hue, particularly for those being presented to the monarch for the first time. Special permission had to be sought to wear black court dress, should the lady being presented be in mourning.

The nineteenth century saw the development in many nations of a distinctive court dress. Some countries such as Russia and Greece followed the Swedish lead and introduced elements of traditional dress into their design. Other countries, as diverse as Venezuela, Norway, and Japan, selected a system of uniforms based on European military patterns. Tailors, in London, Berlin, and Rome in particular, provided a comprehensive service designing as well as manufacturing the garments.

Many of the European courts, where the wearing of court dress had been so enthusiastically promoted, were swept away during World War I. The British court proved more resilient, and in London court dress continued to be worn until the outbreak of World War II in 1939. But Britain emerged from this conflict very changed. The social mores that had underpinned the court system had broken down. Even though court presentation continued until 1958, a special dress was not prescribed.

Court dress is rarely worn in the early 2000s. In most European countries a few particular officials working in the foreign office, parliament, and the law courts may be required to wear it on occasion. In Sweden, Denmark, and Norway since 1988 the wearing of a court dress within the royal family and its immediate circle has been reintroduced for the grandest ceremonial occasions. The new Swedish pattern is based in the eighteenth-century Swedish tradition. The styles in Norway and Denmark are modern creations.

See also **Royal and Aristocratic Dress.**

#### BIBLIOGRAPHY

- Arch, Nigel, and Marschner, Joanna. *Splendour at Court: Dressing for Royal Occasions since 1700*. London: Unwin Hyman, 1987.
- Delpierre, Madeleine. *Uniformes civiles ceremoniales*. Paris: Ville de Paris, Musee de la Mode et du Costume, 1982.
- de Marly, Diana. *Louis XIV and Versailles*. London: B. T. Batsford, Ltd.; New York: Holmes and Meier, 1987.
- Mansfield, Alan. *Ceremonial Costume*. London: Adam and Charles Black, 1980.
- Rangstrom, Lena, ed. *Hovets Drakter*. Stockholm: Livrustkammaren/Bra Bocker/Wiken, 1994.



## COWBOY CLOTHING

Ribiero, Aileen. *Fashion in the French Revolution*. London: B. T. Batsford, Ltd.; New York: Holmes and Meier, 1988.

———. *Dress in Eighteenth Century Europe 1715–1789*. New Haven, Conn.: Yale University Press, 2002.

Joanna Marschner

**COUTURE.** See *Haute Couture*.

**COWBOY CLOTHING** “Cowboys,” “vaqueros,” “gauchos,” each of these words conjures a different image, yet all these occupations originated in the Salamanca and Old Castile region of twelfth-century Spain where cattle herders wore low-crowned hats, bolero jackets, sashes, tight-fitting trousers, and spurred boots. The dress of gauchos, vaqueros, and cowboys may have originated in Spain but new articles of dress were added because of the various environments in which cattle herders



**Typical cowboy outerwear.** While low-crowned hats, leather chaps, and spurred boots have been major components of traditional cowboy garb for centuries, blue jeans are a more recent stylistic addition. © DAVID STOECKLEIN/CORBIS. REPRODUCED BY PERMISSION.

performed their work. The dress of all three changed because of innovations in ranching culture and in technologies used for producing clothing; however, there is one characteristic that still remains among all three groups—their love of flamboyance in dress.

### GaUCHO Dress

The dress of gauchos reflected the influence of Spain while responding to environmental conditions found in South America. Nineteenth-century paintings show them wearing low-crowned hats, vests, and bolero jackets, all having Spanish influence. They also wore *calzoncillos* that bear a remarkable resemblance to petticoat breeches that were fashionable in sixteenth-century Europe. *Chiripá* that consisted of loose diaper-like pants were worn over the *calzoncillos*. The gauchos of Argentina and Chile added ponchos that originated among the native people of the region for protection from cold winds and rains generated by the Andes Mountains that rose above the pampas. During the colonial period, Argentinean gauchos wore *bota de potro*, boots made of the leg skins of colts. By the nineteenth century machine-made boots replaced the *bota de potro* since Argentines enacted laws forbidding use of homemade boots to prevent the killing of colts. The most elaborate part of traditional gaucho's dress was a wide belt called a *cinturon*, trimmed with coins and fastened with a large plate buckle. By the mid-twentieth century, the *calzoncillos* and *chiripá* were replaced by wide-legged trousers called *bombachas* tucked into tall leather boots, but the *cinturon* remained a traditional part of gaucho dress. Gauchos in the twenty-first century still resemble their early-twentieth-century ancestors, since they are dressed in low-crowned, broad-brimmed hats, short jackets, *bombachas* tucked into tall boots, and, most important, *cinturons* decorated with coins and wide plate buckles. Some gauchos still use ponchos, both for decoration as well as for protection.

### Vaquero Dress

Vaqueros of Mexico, the most direct ancestor of the American cowboy, also wore clothing that resembled the clothes worn in Spain, though there were differences. The low-crowned hat, bolero jacket, sash, and spurred boots remained, but a new form of dress developed in the North American Southwest. *Armas* were an early form of chaps made of slabs of cowhide hung from the saddle and folded back to protect a vaquero's legs from the thorny brush that was part of the New World environment. *Chaparejos* that fully enclosed a rider's legs were the next practical evolution of protective gear for Mexican vaqueros. By the late sixteenth century, vaquero dress included a leather *chaqueta* or jacket, a sash, knee breeches called *sotas* that were usually made of leather, long drawers visible under the *sotas*, leather leggings that wrapped to the knee, and spurs attached to buckskin shoes. Vaqueros, too, changed their dress to reflect changing technology and culture. By the mid-nineteenth century, their dress consisted of wide-brimmed, low-crowned hats, short

jackets, thigh-high *chaparreras* tied to a belt at the waist that were worn over trousers, boots and large rowelled spurs. The twenty-first century vaquero wears *chaparejos* that resemble those developed over 400 years ago but he wears a broad-brimmed hat with a higher crown trimmed with a fancy hatband and ready-made shirt and pants.

### Cowboy Dress

**Working cowboys.** Woolie chaps, made of leather with the hair left on, originally developed in California, were introduced to northern cowboys by vaqueros who drove cattle from Oregon to Montana mining camps during the 1860s. They did not represent cowboy culture until the cattle industry had expanded to the northern plains during the 1880s when woolies, as they were called, were particularly useful for protecting cowboys from the cold that was a part of northern plains life.

**Dude ranch dress.** Eastern visitors to the West still sometimes buy flamboyant cowboy gear but they are more likely to do their horseback riding in running shoes and T-shirts instead of cowboy boots and satin shirts. One reason for this is that most dude ranch visitors no longer spend six to eight weeks on western ranches summer after summer, but visit a dude ranch for one or two weeks once in a lifetime.

### Twenty-First-Century Western Dress

Cowboy dress is important in American culture, especially to those who live in the West. Often formal events are excuses for westerners to put on their best western outfits consisting of broad-brimmed Stetson hats, western-cut shirts with curved yokes and pearl snaps, tooled belts with fancy plate buckles (or trophy buckles if available), tight, boot-cut jeans, and high-heeled boots. Even ladies dress up in their best Native American jewelry, well-cut western shirts, full skirts, and high-heeled boots. Western style is hard to resist.

Gauchos, vaqueros, and cowboys are important in South and North American folk culture. All three repre-



**Close-up of spur.** Mexican *vaqueros* began attaching spurs to their shoes around the sixteenth century, and they have remained a traditional part of cowboy attire. © DAVID STOECKLEIN/CORBIS. REPRODUCED BY PERMISSION.

sent fierce independence and self reliance but it is their clothing and gear that defines each group. Gauchos are recognized by their tall boots, wide-legged pants, coin-decorated belts, and wide-brimmed hats. Vaqueros wear sombreros that have decorated high crowns and very broad brims. They still wear *chaparreras* and boots and fancy spurs, but their pants and shirts are more formal than those worn by their ancestors. Cowboys often wear Stetson hats that have broad brims, bright-colored shirts, and blue jeans that are now part of the cowboy image. Slant-heeled cowboy boots, spurs, and tooled belts with fancy buckles are also part of the cowboy image. Rodeo cowboys now wear chaps made of leather embellished with Mylar in bright colors like shocking pink and turquoise that flash in the sun as the cowboys demonstrate their skills in the arena. Although gauchos, vaqueros, and cowboys can trace their origin to Spain, little in their appearance reflects the dress of twelfth-century Salamanca. Instead, each wears the clothing that developed because of changes in technology and culture.

See also **America, Central, and Mexico: History of Dress; America, North: History of Indigenous Peoples Dress; America, South: History of Dress; Boots; Fashion and Identity; Hats, Men's; Jeans; Protective Clothing.**

#### BIBLIOGRAPHY

- Bisko, Charles. "The Peninsular Background of Latin American Cattle Ranching." *The Hispanic American Historical Review* 32, no. 4 (November 1952): 491–506.
- Cisneros, Jose. *Riders Across the Centuries: Housemen of the Spanish Borderlands*. El Paso: University of Texas, 1984.
- Dary, David. *Cowboy Culture*. Lawrence: Kansas University Press, 1989.
- Slatta, Richard. *Cowboys of the Americas*. New Haven, Conn.: Yale University Press, 1990, p. 34.



"He was dressed like a Wild West Show cowboy, with such . . . extras as . . . a bandanna worn full in front like a lady's big bertha collar, instead of tied tight around the neck to keep dust out and sweat from running all the way down into your boots." Bronco Billy Anderson, a real cowboy who starred in *The Great Train Robbery*.

Cary, Dianna Serra. *The Hollywood Posse*. Boston: Houghton Mifflin, 1975, p. 17.

## CREPE

Taylor, Lonny, and Ingrid Marr. *The American Cowboy*. Washington, D.C.: Library of Congress, 1983.

Wilson, Laurel. "American Cowboy Dress: Function to Fashion." *Dress* 28 (2002): 40–52.

Laurel E. Wilson

**CREPE** "Crepe" is the name given to fabric having a crinkled or pebbled texture, often used for blouses and dresses with graceful drape. Almost any fiber may be used, and the fabric can be thin and sheer, fine and opaque, or even heavy. Crepe (alt. crape) fabric may be stretchy, requiring care to cut and sew accurately. Its distinctive surface may be achieved by taking advantage of yarn twist, by arranging a suitable weave structure, by employing uneven warp tension, or by applying a chemical treatment.

The first type utilizes the kinetic energy of two kinds of tightly-spun weft yarns (yarn that runs crosswise)—one



**Crepe de chine wrap.** Crepe de chine is a crepe made from silk or a similar thin, lightweight fabric. These crepes have a subtle luster and are frequently painted. © CONDÉ NAST ARCHIVE/CORBIS. REPRODUCED BY PERMISSION.

S-twisted and the other Z-twisted—(spun so that the twists angle upward to the left or to the right, respectively), which are alternated singly or in pairs in a plain-weave cloth. Upon release from the loom's tension, the springy yarns attempt to unwind within the confines of the web, thus imparting the characteristic rippled surface of "flat crape" or *crêpe lisse*, as it was known in the nineteenth-century. Occasionally this technique is used in both warp (yarn that runs lengthwise) and weft, as in early nineteenth century Chinese export silk shawls. Georgette is a sheer, crisp, flat crepe; chiffon, a relatively modern fabric, is also sheer and crisp but has a smooth, uncraped surface. Since the terms "flat crepe" and *crêpe lisse* seem to have passed from common use, this fine crepe seems to have acquired the default name of "chiffon" as well.

The second type of crepe is made of yarns with ordinary twist in a weave having small, irregular floats that look fairly bumpy. This method is most effective in heavy fabrics whose larger threads produce an appreciable texture.

The third type of crepe, seersucker, has warpwise puckered stripes resulting from slack tension in the weaving. When the cloth is released from the loom's tension, it relaxes to a shorter length with closer-spaced wefts than the puckered stripes, which are forced to bulge from the fabric plane. It is usually an ideal choice for summer suiting, underwear, pajamas, and children's wear because it sheds wrinkles and needs no ironing.

The fourth crepe requires the application of a special finish that causes the fabric to shrink wherever it is applied. The method was first patented in England in 1822, when a plain, thin silk gauze stiffened with shellac was passed under a heated, engraved copper cylinder to receive embossed patterns. At this time, heavily textured crepes, particularly the printed varieties, were called "crepe." The term for flat crepes—*crêpe*—eventually came into use for all, no doubt because of the irresistible fashion cachet of anything French.

Heated, engraved rollers are still used to impress chemicals on cloth to make puckered "plissé" designs that may not be permanent. However, cottons printed with alkali are permanently altered by shrinkage. Synthetics, being heat sensitive, can be craped handily and permanently not only at the factory, but inadvertently at home by a mismanaged iron.

Well into the twentieth century, crisp, dull black, silk mourning "crepes" were woven in the gum and heat-treated with chemicals to produce the characteristic deeply grooved texture.

See also **Fibers; Mourning Dress.**

### BIBLIOGRAPHY

Denny, Grace G. *Fabrics*. 4th ed. Chicago: J. B. Lippincott, 1936.

Montgomery, Florence. *Textiles in America*. New York: W. W. Norton and Company, 1984.

Susan W. Greene



**CRINOLINE** In the mid-nineteenth century, the ideal feminine figure was an hourglass above a broad base of full skirts. Wide skirts, which made the waist look smaller and were thought to give women dignity and grace, were supported by layers of petticoats, some made of crinoline, a stiff fabric woven from horsehair (the name derives from the French *crin*, horsehair, and *lin*, linen). Crinoline, however, was expensive, heavy, crushable, easily soiled, and could not be cleaned. To enable women's skirts to become as immense as fashion desired, a more effective skirt support was needed. Petticoats were distended with cane and whalebone—and even with inflated rubber tubes—but with limited success.

In 1856, a new support was introduced, made of graduated, flexible sprung-steel rings suspended from cloth tapes. The names for these structures included “hoopskirts,” “steel skirts,” and “skeleton skirts”; they were also called “crinolines,” since, confusingly, this term was applied to all skirt expanders, and sometimes referred to as “cage crinolines” or “cages.”

Indeed, some have perceived hoopskirts as cages imprisoning women. The hindrance of hoops reflected the ideal, cloistered social role of women of the time, who were, as a male commentator in *Godey's Lady's Book* of August 1865 (p. 265) put it, “unfitted by nature and constitution to move easily or feel in their place in the bustle of crowds and the stir of active out-door life.” To many Victorian women, however, hoopskirts promoted “a free and graceful carriage” and were hailed as a blessing. In contrast to numerous hot and heavy petticoats, hoopskirts were lightweight, modest, healthful, economical, and comfortable.

Hoopskirts were a marvel of contemporary technology and manufacturing, with many possible variations in construction. Most hoopskirts were made using tempered sprung steel, which had an incredible ability to return to shape. This was rolled into thin sheets, cut into narrow widths, and then closely covered in cotton tubular braid finished with sizing to give a smooth surface. To make a hoop, a length was cut and the ends secured, usually with a small piece of crimped metal. Graduated hoops were then arranged on a frame in the desired shape and suspended from cotton tapes, secured either by metal studs or put through specially made double-woven pockets in the tapes. At the top, partial hoops left an opening over the stomach so the hoop could be put on and secured by a buckled waistband. The entire hoop weighed a mere eight ounces to less than two pounds.

The large skirt supports of earlier centuries, such as the Elizabethan farthingale and the eighteenth-century pannier, had been the preserve of the upper classes; by the mid-nineteenth century, however, more women could participate in fashion. Middle-class women and even maids and factory girls now sported hoopskirts, although their cheaper versions had twelve or fewer hoops while more expensive models with twenty to forty hoops

gave a smoother line. The pretensions of the “lower orders” was one of the many aspects of hoops that inspired caricaturists. Also ridiculed—and exaggerated—was the balloon-like appearance of overdressed ladies in immense hoops and flounced skirts. (At the extreme, hoopskirts could be up to four yards in circumference, although three yards or less was more common.) More risqué cartoons highlighted the tendency of springy hoops to fly up revealingly; for modesty's sake, many respectable women now adopted long loose underpants or drawers.

The demand for hoopskirts was so great that factories flourished across the United States and Europe. *Harper's Weekly* of February 19, 1859 (p. 125) claimed that two New York factories each produced 3,000 to 4,000 hoopskirts per day. As production continued to increase throughout the 1860s, the hoopskirt industry employed thousands, consumed vast quantities of raw materials, and utilized the latest technologies. As numerous patent applications show, great ingenuity was applied to creating improved hoop machinery and specialized features. Advertisements touted the superiority of their products and gave them impressive names, such as “Champion,” “Ne Plus Ultra,” and one brand named after the fashion icon of the time, the French empress Eugénie.

During the era of the hoop, skirt silhouettes gradually evolved. The dome-shaped skirts of the 1850s gave way to tapered skirts that flared from waist to hem, so supports were correspondingly smaller on top and often had hoops only below the knee. Hoopskirts similarly responded to the fluctuations of fashionable skirt lengths. When the hoop was first introduced, women's skirts touched or nearly touched the ground, but shorter skirts increasingly became the rage in the 1860s, and skirts also began to be looped up over a shortened underskirt for walking, causing what some claimed was an “unseemly display of ankle.” In the same period, trained skirts, dragging nine inches or more on the ground, also became increasingly fashionable; by the mid-1860s hoopskirts were specially designed with extra fullness at the bottom back to gracefully support and keep the train away from the feet.

The demise of the hoop skirt was forecast by fashion arbiters from the time of its introduction, yet hoops remained indispensable to most women throughout the 1860s. By the very late 1860s, attention shifted to the back of the skirt and emphasis was on the bustle which now augmented the hoop. As bustles became more pronounced, the hoop was definitively declared out of fashion by the early 1870s. However, even into the 1880s some women wore small hoops—as little as eighteen or even sixteen inches in diameter, which must have been a hindrance when walking—to keep their skirts clear of their legs.

Marvels of technology, industry, and ingenuity, hoopskirts perfectly suited the societal and aesthetic needs of their time. In the November 1861 issue of

*Peterson's Magazine* (p. 384), one writer went so far as to declare hoopskirts "a permanent institution, which no caprice of fashion will be likely to wholly destroy." While fashion soon belied this prediction, the hoop did enjoy a remarkably long reign, and stands as the defining garment of its era.

In the twentieth century, the hoop skirt was revived under full-skirted evening dresses, or *robes de style*, in the late 1910s and 1920s and, most famously, as nylon net "crinolines" and featherboned hoopskirts supporting bouffant New Look and 1950s fashions. The recurring popularity of hoopskirted looks for romantic occasions such as weddings continues to keep this extremely feminine fashion alive even into the twenty-first century.

See also **Petticoat**.

#### BIBLIOGRAPHY

- Adburgham, Alison. *A Punch History of Manners and Modes, 1841–1940*. London: Hutchison & Co., 1961.
- Calzaretta, Bridget. *Crinolineomania: Modern Women in Art*. Exhibition catalogue. Purchase, N.Y.: Neuberger Museum, 1991.
- Cunnington, C. Willett. *English Women's Clothing in the Nineteenth Century*. London: Faber and Faber, 1937 (republished New York: Dover Publications, 1990).
- Gernsheim, Alison. *Fashion and Reality: 1840–1914*. London: Faber and Faber, 1963 (republished as *Victorian and Edwardian Fashion: A Photographic Survey*. New York: Dover Publications, 1981).
- Severa, Joan. *Dressed for the Photographer: Ordinary Americans and Fashion, 1840–1900*. Kent, Ohio: Kent State University Press, 1995.
- Waugh, Norah. *Corsets and Crinolines*. New York: Theatre Arts Books, 1954.

H. Kristina Haugland

**CROCHET** Crochet, from the French for hook, is a form of needlework consisting of a doubly interlooped structure built from a chain foundation. The basic stitch is a simple slip loop yet a multitude of different stitches may be created by varying the number of loops on the hook and the ways in which they are integrated with the structure. Hooks of varying fineness are frequently made of metal, wood, or bone, and common threads used are cotton, wool, silk, or linen. This versatile and potentially rich and complex craft has been practiced by both men and women in many countries. Perhaps the most ubiquitous item of crocheted clothing today is the *kufi* cap, often worn by Muslim men.

#### Origins and History

Researchers have encountered considerable difficulty finding early examples of crochet, in contrast to woven or knitted artifacts. The textile scholar Lis Paludan has conducted extensive research into the origins of crochet

in Europe but has been unable to document its practice before the early 1800s. Yet items of crocheted clothing from India, Pakistan, and Guatemala can be found in museum and private collections; non-European traditions of crochet would seem a promising area for future investigation.

Crochet in Europe seems to have developed independently in two quite different milieus. As with knitting, this technique was used to create insulating woolen clothing for use in inclement climates such as Scandinavia and Scotland, where an early-nineteenth-century version of crochet, known as shepherd's knitting, worked with homemade hooks improvised from spoons or bones. Through wear or design, these items became felted, offering further protection against the elements. Simultaneously, in the more leisured climate of the female drawing room, another form of the craft was developing out of a far older type of needlework called tambouring. Apparently originating in India, Turkey, and Persia, tambouring was executed with a very fine hooked needle inserted into fabric stretched over a frame. The transitional step was to discard the fabric and execute the looped chain stitch "in the air" as it was termed in France.

This latter form of crochet developed in Europe and the United States during the nineteenth century, primarily as a women's activity. Numerous crochet patterns appear in women's magazines of this period, ranging from conventional clothing applications such as collars, bonnets, scarves, blouses, slippers, and baby wear to such fantastical creations as birdcage covers. Museum collections contain a wealth of crocheted purses and bags from the second half of the nineteenth century. Some of the finest are miser's bags, worked with fine colored silks and tiny glass or steel beads. These bags were rounded at both ends or curved at one end and square at the other and had a small opening through which coins would fit.

By the middle of the nineteenth century, patterns for Tunisian crochet began to appear. This was a hybrid knitting/crochet technique capable of producing a firm, stable structure for clothing such as shawls, waistcoats, and children's dresses. The technique was also called Afghan stitch and is still practiced in southeastern Europe, suggesting other geographic avenues for further research into crochet's origins and dissemination.

While crochet was a pursuit of the leisured classes, it was also a cottage industry, providing economic relief in rural areas from the effects of industrialization and displacement. The most famous example of this industry, which produced some outstanding examples of crocheted clothing, was Irish crochet. This fine lacelike form (also called *guipure* lace) probably developed out of an economic imperative to find a cheaper alternative to needlepoint lace and bobbin lace. A variety of floral-like motifs were finely crocheted in cotton over thicker threads, and joined together with fine mesh to produce a lacelike structure often of great intricacy and delicacy. During the

potato famine (1845–1850) Irish crochet provided a form of sustenance to hundreds of Irish peasant families. As with many cottage industries of this period, it was organized by upper-class philanthropic women who arranged classes and distribution (through agents) of inexpensive and widely fashionable Irish crochet collars, cuffs, and accessories. Irish crochet's success and dissemination through international exhibition led to its practice as an industry in several European countries such as France, Austria, and Italy, and clothing of Irish crochet was imported into the United States and Canada.

During the first part of the twentieth century interest in crochet waned; the ubiquitous crocheted plant holders and hot water bottle covers, often executed in heavy, coarse yarns, were indicative of a foundering creativity where repetition of form was matched by a decline in technical skill. As might be anticipated, though, the craft revival of the late 1960s and 1970s inspired renewed experimentation. Fiber artists realized that by crocheting in the round, crocheting free-form rather than by working in rows, and building up three-dimensional forms from the surface of the fabric, they could produce elaborate wearable sculpture. The increasing range of alternative yarns and the production of often imaginative and humorous garments led to an appreciation of the art form as a vehicle for self-expression.

At the same time, crochet's perceived status as an undervalued women's activity, and its accumulated associations with amateurism, were countered head-on by the conceptual art movement. Crochet became radicalized. Perhaps its best-known proponent in this field was Robert Kushner, who crocheted clothing to be used as performance art.

### Ready-to-Wear and Couture

Unlike knitting, crochet has never become fully mechanized. Hence, it has not been a popular form of construction for ready-to-wear clothing. Discrete crocheted edging sometimes appears on the work of fashion designers best known for their knitwear, such as Adolpho. Otherwise, crochet has been used to great effect as part of the armory of couture techniques. The British design team Body Map has employed it in tongue-in-cheek homage to its "homemade" essence. The Irish designer Lainey Keogh uses knitting and crochet to celebrate a sensuous femininity. Vivienne Westwood has absorbed crochet into her stable of elaborate embellishment techniques and used it with aplomb on her reworkings of historical costume. Jean Paul Gaultier has combined knitting and crochet in ways that celebrate and subvert traditional patterns.

Crochet is an outstandingly versatile technique whose applications have ranged from the most basic utilitarian to haute couture. Over the past two centuries it has cycled in and out of fashion, but its potential for creative experimentation has regenerated attention from

those who engage in it as a leisure pursuit, as well as professional designers. Regarding clothing and fashion, its potential for a mass market seems enormous if it were to become more mechanized.

*See also* **Knitting.**

### BIBLIOGRAPHY

Helpful primary sources would include women's journals from the nineteenth century, which contain a wealth of crochet patterns. See, for example, *The Delineator*, *Harper's Bazaar*, *Ladies' Home Journal*.

Black, Sandy. *Knitwear in Fashion*. New York: Thames and Hudson, Inc., 2002. Although focusing on knitwear, illustrates application of crochet in contemporary designer fashion.

Boyle, Elizabeth. *The Irish Flowerers*. Belfast, Ireland: Ulster Folk Museum and Institute of Irish Studies and Queen's University, 1971.

Paludan, Lis. *Crochet: History and Technique*. Translated by Marya Zanders and Jean Olsen. Loveland, Colo.: Interweave Press, 1995. Comprehensive review of history of crochet in Europe, with section on technique and reproductions of patterns from the nineteenth century.

*Lindsay Shen*

**CROSS-DRESSING** Cross-dressing occurs for religious reasons, for burlesque, disguise, status gain, even for sexual excitement. It is as old as clothing itself. Mythology and history are full of cross-dressing incidents, mainly of men dressing or acting as women. Women cross-dressing and living as men began to appear in the early Christian Church where there are a number of women saints who were found to be women only upon their death. In fact, women living as men seemed to have been more successful at it in the past three centuries than men living as women, perhaps because their motivations were different. Many of them did so to overcome the barriers that women had to face in terms of economic opportunities and independence in the past.

Anthropologists, impressed by the variety of cultures where cross-dressing and gender change have been found, developed the term "supernumerary gender" to describe individuals who adopt the role and many of the customs of the opposite sex. In American Indian culture, for example, men who took on the roles of women were called berdaches. Berdaches took over special ceremonial rites and did some of the work attributed to women, mixing together much of the behavior, dress, and social roles of women with those of men. Often one can gain status by changing gender identification. Among one group of Blackfoot Indians, there are women known as "manly hearts," who have the character traits associated with men and often adopt the male role and clothing. Some groups such as the Navajo identify three, not two, sexes and designate the nonconformist to the third sex. Several identify more than three genders.





**Hindu eunuchs.** Members of the Sakhībhāva cult emulate women, often to the extent of being castrated, due to their belief that the god Krishna is the only true male being in the world. © KARAN KAPOOR/CORBIS. REPRODUCED BY PERMISSION.

Male cross-dressing is part of religious worship in different Hindu sects. Sakti worshipers consider the godhead be essentially feminine, and men present themselves in women's costumes. In one Hindu cult, the Sakhībhāva, which holds that the god Krishna is the only true male while every other creature in the world was female, male followers dress like women and affect the behavior, movements, and habits of women, including imitating having a menstrual period. Many of them also emasculate themselves, and play the part of women during sexual intercourse, allowing themselves to be penetrated as an act of devotion. The technical term for these men is *bijra* (eunuch or transvestite). Some observers have called them homosexuals, although it is probably better to regard the role as asexual.

Such androgynous beliefs are not confined to Hinduism but exist in sects of other religions as well. In Islamic Oman, the Xanith are regarded by Oman society as neither male nor female but having the characteristics of both. Though they perform women's tasks, are classed as women, and are judged for beauty by women's standards, technically they do not cross-dress. Instead, they feminize their male costume in every way possible. A Xanith, how-

ever, can change her or his status in society by marrying and demonstrating his ability to penetrate a woman.

Because Islam is such a sex-segregated society, and public appearances by women limited, many Islamic areas have tolerated and institutionalized female impersonators. In Egypt one group is called *khūal* ("dancers"). They perform at weddings and other ceremonial occasions, and though technically their costume is not quite like that of women, they do all they can to appear as women, including plucking out hairs on their face.

Though women's roles were not quite so restricted in the West, there were still strong prohibitions. They could not appear on the stage, for example, and women's roles were taken by female impersonators until the seventeenth century. This was also true in Japan, and in other countries as well, including ancient Greece.

The earliest recorded historical woman to dress and act like a man was Hatshepsut, an Egyptian from about the fifteenth century B.C.E. She is even portrayed in statues and carvings wearing a symbolic royal beard. After her death there was an attempt to obliterate her memory, but her record managed to survive. History, how-

ever, is less kind to male rulers who cross-dressed. A good example of this is the Assyrian king Sardanapulus (also known as Ashurbanipal) in the fifth century B.C.E., who is said to have spent much of his time in his palace dressed in women's clothing and surrounded by his concubines. When news of this behavior became widely known, some of his key nobles revolted. Although his cross-dressing was looked down upon because it showed feminine weakness, he fought long and bravely for two years, and before facing defeat, he committed suicide.

Greek literature is full of cross-dressing in both mythological tales and actual events. Greek writers reported that among the Scythians there were groups of individuals known as *Enarées*, who had been cursed with the feminine disease by the god Aphrodite for raiding her temple. Another Greek writer claimed that their cross-dressing was brought on by a temporary impotency caused by spending so much of their time on horseback. Cross-dressing was also part of religious rituals in Greece itself, usually as part of an initiation ceremony emphasizing the essential opposition between the male essence and the female one. Young men at such ceremonies appeared initially in women's clothing and after being initiated into manhood, tossed them aside. Cross-dressing figured prominently in the religious ceremonies associated with the god Dionysus, who according to some legends had been reared as a girl. Other gods and goddesses also required their worshippers to cross-dress at least some of the time. The ubiquity of such festivals might well indicate that the Greek who drew strict lines between sex roles and assigned a restricted role to women, needed periods during which the barriers were removed.

In Sparta, where marriage for men was delayed until they were thirty, men had to live in segregated barracks even after they were married. When they did marry, the young bride (probably a 14-year-old) was dressed in male clothing so that her husband could sneak away and come secretly to her in the night. She was not able to resume her traditional clothing until she had become pregnant, a true sign of womanhood.

Clearly temporary assumption of opposite gender by men was acceptable if the aim was laudable or if the alternatives to the impersonation were considered more socially undesirable than the disguise itself. Hymenaeus, a youth from Argive, disguised himself as a girl to follow the young Athenian maid he loved. Solon is said to have defeated the Megarians by disguising some of his troops as women to infiltrate the enemy forces. Achilles, in order to be protected from potential enemies, was said to have lived the early part of his life as a girl and was finally exposed by Odysseus. The legends are bountiful.

Latin literature, particularly of the imperial period, has a number of stories of cross-dressers. Julius Caesar found a man dressed as a woman at religious ceremonies held in his house who was there to arrange an assignation. The Emperor Nero cross-dressed, and so did the

Emperor Elagabalus, who was proclaimed emperor as a fourteen-year-old boy in 218. In both of these cases, however, their cross-dressing was regarded as an indicator of their flawed character.

Christianity was hostile to cross-dressing, as was Judaism from which it derived. But as indicated above, a number of female cross-dressers are known, many of whom became saints. When their true sex was discovered, usually at their death, they were praised for their faithfulness and saintliness, and their ability to rise above female frailties. There were limits, however, on what was acceptable.

A recently discovered Medieval Romance, *Le Roman de Silence*, tells the story of a girl raised as boy in order to preserve the inheritance of her parents. Silence is told by her parents in her early teens that she is really a female; but, though torn by her "feminine desires," she maintains the male role until she is permitted to resume the woman's role by the king. There are other stories as well, but the easiest to document are the male actors who played feminine roles on the stage until they became too old to do so, up to the middle of the seventeenth century. Occasionally a legal case reports a cross-dresser, as did a London city record of a male prostitute who plied his trade as a woman. Even the woman's role in many operas was sung by castrati, a castrated male, until the nineteenth century.

Cross-dressing and impersonation was generally easier for a female to do than a male simply because of the beard problem. This meant that on the stage it was adolescents or young men who usually played the feminine role. Females, for their part, could pass as young men wearing loose clothing until fairly late in their life, and then with a false beard continue to do so. Some young enterprising Dutch girls served as seamen on ships bound for Indonesia, where they settled down. Many women fought as men in most wars and continued to do so until the twentieth century, when pre-induction physicals were established in the American and other armies.

Even the most dedicated transvestite, the Abbé de Choisy (1644–1724), whose memoirs of his life as a woman survive, more or less abandoned his public attempts to pass as a woman as he aged. He continued to cross-dress when the opportunity presented itself, but his identity was no longer a secret. To keep himself entertained he wrote fictional accounts of cross-dressing.

It was in eighteenth-century London where cross-dressing organizations appeared. A number of men's-only clubs were established and some of them became quite notorious. One group, known as the Mohocks, went out at nights regularly seeking lower-class women and girls whom they stood on their heads so that their skirts would fall down, exposing their bare bottoms. Not all clubs of this period, however, were quite so boisterous. One of the more subversive of the male tradition was the Molly club, whose members met in women's clothes to drink

and party; Edward Ward, who in 1709 wrote *The Secret History of Clubs*, described their meeting where they dressed as women:

They adopt all the small vanities natural to the feminine sex to such an extent that they try to speak, walk, chatter, shriek and scold as women do, aping them as well in other aspects. . . . As soon as they arrive, they begin to behave exactly as women do, carrying on light gossip, as is the custom of a merry company of real women. (p. 209)

Whether this club was an organization of homosexuals is not clear, but several historians believe that this was part of an attempt to establish a distinct gay identity.

Certainly there was a growing curiosity about cross-dressing and impersonation in public in both England and France in the eighteenth century. The most notorious cross-dresser was Charles d'Eon, known as the Chevalier d'Eon, who was a member of the personal secret service of the French King Louis XV. D'Eon apparently used his ability to pass as a woman to carry out his spying tasks, and later as he became involved in a struggle with the French government under King Louis XVI, he received a pardon from the King, providing he dressed as a woman that the king believed him to be and lived in exile. When gambling in England over his sex reached a peak, he apparently was involved in a bribery scheme in which two English physicians testified he was a woman, whereby his friends collected some money. For a time he became a sensation in Paris and in London, burlesquing the gestures and mannerisms of women, and when he ran into financial difficulties in England he supported himself by his expertise with the sword. He gave exhibitions and lessons while dressed in proper women's attire. He died in poverty in 1810; as his body was being prepared for burial, he was found to be a male. He might be called the first transvestite to become a media event.

It was not until the last part of the nineteenth century that cross-dressers appeared in ever-increasing numbers. That period in history is when distinctions between male and female domains were strongly entrenched in the upper and middle classes. It was also when there was an increasing emphasis on sports and manliness in these circles. Carried to an extreme, the demands of masculinity could turn to a kind of bullying, as it often did in the English public schools. In America, masculinity, at its worst, was a kind of anti-intellectualism in which music, literature, and all the "finer" things were feminine, and those boys who were interested or excelled in those pursuits were defined by the dominant male group as feminine. Terms such as *queer*, *fag*, *fairly*, or even *girlish* were applied to boys who outwardly seemed to express an interest in anything assigned to the women's sphere. This continued on until the rise of the new wave of feminism in the 1960s. In my own studies of cross-dressers carried out in the 1980s, I found that the male cross-dressers who identified themselves as heterosexual had adopted an almost dichotomized personality in their youth. They were

well adjusted outwardly to the male world, but in order to express what they regarded as the feminine side of themselves, they felt a need to cross dress. In this way they could express, even temporarily, some of the feminine qualities they felt they had but then safely return to the masculine identity.

The separate-sphere concept tended to make women less understandable and more mysterious to men; the stricter the separation, the more defined the spheres, the more mysterious women were. One result of this was the fetishization of women's apparel. Women spent a good part of their time trying to better understand men's needs as mothers, caregivers, and teachers, but men, rather than attempting to understand women, objectified and eroticized objects identified with the female, such as underclothes or even outer clothing. In some ways clothing seemed to be the ultimate of being female.

At the same time female clothing was eroticized. The corset is a good example since it was not sold as a waist cincher or form maker but as a preserver of feminine virtue. Corsets also helped rearrange the female figure, emphasizing a narrow waist and resultant hourglass figure that gave prominence to the bust and buttocks. One of the more interesting results of this was the growth of what might be called "corset literature," aimed at a male audience. In this fictional literature adolescent boys are put into corsets to form their figures and to feminize them. In the late nineteenth and first part of the twentieth century, such literature was widespread. Eroticization of clothing was undoubtedly influenced by the fact that so many of the items of women's apparel were designed to emphasize or bring attention to certain aspects of the female figure, from bras to nylon stockings to high heels. High heels, for example, force the wearer to lean backward, thereby accentuating the buttocks and the breasts. Heels also force women to walk with smaller steps emphasizing their supposed helplessness. It was almost as if clothing made the woman. Men wearing it would often get an orgasm.

A number of plays were written in the last part of the century that included plots in which men had to get into women's clothes. Oscar Wilde's *The Importance of Being Earnest* is just one example. There were so many impersonator parts that some men made a career of playing them, including Ernest Boulton and Frederick William Park. They also dressed as women while offstage and were arrested for soliciting men.

Cross-dressing, in fact, had a significant role in the growing gay community. One way they could come together in public was in the masquerade or cross-dressing balls that began to be held in significant numbers in major urban centers in the late nineteenth century and continued through the twentieth. Not all cross-dressers, however, were homosexual and the phenomenon came under serious study by two pioneering sexologists, Havelock Ellis and Magnus Hirschfeld.





**Advertisement for cross-dressing club.** Though women still impersonate men, for them it is frequently more about the societal freedom than the clothing. With male cross dressers, wearing female clothing is usually an important part of the experience.

© RYKOFF COLLECTION/CORBIS. REPRODUCED BY PERMISSION.

Ellis called the phenomenon *eonism*, after the Chevalier, while Hirschfeld coined the term “transvestism.” Their pioneering studies were neglected by Americans, particularly Hirschfeld, who was not translated into English until the 1990s. The study of cross-dressing received renewed emphasis through the case of Christine Jorgensen, which received international publicity in 1952. Interestingly, the physician involved in the case called her a transvestite, and only gradually was the phenomenon of transvestism distinguished from transsexualism.

Organized transvestism began in the United States in 1959 through the efforts of Virginia Prince, a Los Angeles resident, who began meeting with a group of fellow transvestites she had met in a Hose and Heels club. She quickly emerged as a spokesperson for what she called heterosexual transvestites, to distinguish them from gay queens and transsexuals. The movement spread rapidly around the world so that there are clubs or groups with a variety of names in the majority of the countries of the world. In the United States there are competing national organizations and a lot of local groups that have no affiliation. Coinciding with this growth was the increase of merchants to supply clothes and accessories to would-be cross-dressers, whether gay, straight, or in between.

Interestingly, many of the cross-dressers in the organized groups dress in the style of clothes that were popular when they were young, almost as if there was an imprinting of what a woman should be. They seem to ignore the freedom that women have in clothing, and few of them for example, wear pants even if they lack a fly. One of the objectives of a significant number of transvestites is to appear in public as a woman without being read. This is the ultimate example of a cross-dresser. It is only the most daring of cross dressers who even belong to the organized groups, and it is estimated that there are hundreds of thousands of secret male cross-dressers who are closeted, keeping their clothes in a special suitcase or drawer, to be pulled out when the opportunity arrives. Often the only public indication of their secret life is in buying clothes, through catalogues or getting literature on the topic. Many have wives or significant others who do not know, although in organized transvestism there are wives and other female support groups to help them cope with the cross-dressing activities of the men in their lives.

Though women still impersonate men, it is not the clothing that interests most of them. With the clothing freedom women have, and the increasing breakdown of

barriers to job and other economic opportunities for women, cross-dressing, in the sense that the men involved take part in, is almost nonexistent.

See also **Fashion and Homosexuality; Fashion, Gender and Dress; Politics and Fashion.**

#### BIBLIOGRAPHY

- Allen, Mariette Pathy. *Transformations: Crossdressers and Those Who Love Them*. Boston: Dutton, 1990.
- Boyd, Helen. *My Husband Betty*. New York: Thunder Mouth Press, 2003.
- Bullough, Vern L., and Bonnie Bullough. *Cross Dressing, Sex, and Gender*. Philadelphia: University of Pennsylvania Press, 1993.
- . *Gender Blending: Transgender Issues in Today's World*. Buffalo, N.Y.: Prometheus Books, 1997.
- Docter, Richard. *Transvestites and Transsexuals: Toward a Theory of Cross-Gender Behavior*. New York: Plenum, 1988.
- Ellis, Havelock. "Eonism." *Studies in the Psychology of Sex*, vol. 2, part 2. Reprinted New York: Random House, [1906], 1936.
- Garber, Marjorie. *Vested Interests: Cross Dressing and Sexual Anxiety*. New York: Routledge, 1997.
- Hirschfeld, Magnus. *Transvestites*. Translated by Michael Lombardi-Nash, Preface by Vern L. Bullough. Buffalo: Prometheus Books, 1991.
- Vera, Veronica. *Miss Vera's Finishing School for Boys Who Want to Be Girls*. New York: Bantam-Doubleday Dell, 1997.
- Ward, Edward. *The Secret History of Clubs*. London: 1709, p. 290.

Vern L. Bullough

**CROWNS AND TIARAS** Throughout history, men and women of status have adorned their foreheads with various kinds of crowns and tiaras, which symbolized social superiority and power.

The ancient Egyptian pharaohs favored gold headbands that were sometimes decorated with tassels and other ornaments hanging over the forehead, temple, and down to the shoulders. A precious example was discovered in the tomb of Tutankhamun, King of Egypt in ca. 1339–1329 B.C.E. The excavation of his tomb in 1922 revealed the young king's mummy adorned with a gold diadem formed as a circlet. At the front was a detachable gold ornament with the head of a vulture and the body of a cobra, symbolizing the unification of Lower and Upper Egypt.

The origin of the term "diadem" is derived from the Ancient Greek "diadein," which means "to bind around." Diadems were made from all kinds of metal, and with only a limited amount of gold available, Greek craftsmen decorated them with embossed rosettes or other motifs, including the Heracles knot, a reef knot often found in Hellenistic jewelry. After Alexander the Great opened up the gold supply from the Persian Empire in 331 B.C.E., the styles became less austere and diversified into intricate garlands of leaves and flowers.

The Romans expanded on the fashion for gold headbands, adding precious stones to their designs. The first real diadem, a golden band with a raised point at the front, is attributed to the Roman Emperor Gaius Valerius Diocletianus (C.E. 245–313). According to the British historian Edward Gibbon, (1737–1794), "Diocletian's head was encircled by a white fillet set with pearls as a badge of royalty." "Fillet" is another word for a narrow decorated band encircling the hair.

The term tiara, in its original form, describes the high-peaked head decoration worn by Persian kings. It was later adapted as the Pope's headwear with a second and third crown added in the twelfth and thirteenth centuries, thus making up the Papal Triple Crown, which is used at the Vatican on ceremonial occasions.

To decorate the head with flowers or leaves was an ancient custom and signified honor, love, or victory. The Greeks celebrated victory in games by crowning the champions with a wreath made of natural laurel leaves. The Romans continued the tradition, but took it a step further by honoring their victorious generals with wreaths made of real gold, thus metaphorically turning perishable natural foliage into the eternal. While Roman conquerors were honored with golden wreaths of glory, Roman brides wore natural ones, made of flowers and leaves. Dressed in a white tunic and shrouded under a veil, the bride wore a bridal wreath symbolizing purity of body and soul. Lilies symbolized purity; wheat, fertility; rosemary, male virility; and myrtle, long life—metaphors followed by brides over the course of centuries thereafter. Symbolism was quintessential in the design of all ceremonial headwear. Emblems of victory, signs of virginity, or symbols of sufferance, like the crown of thorns placed on the head of Jesus Christ, were to play a part in the formation of religion, literature, and legends.

Tiaras were not popular during medieval times, as the demure fashion of the time dictated that a woman's head and hair should be covered by cone-shaped hats with soft or stiffened veils. The advent of the Renaissance changed social values again, and hair was allowed to assert its natural beauty with elaborate ringlets and waves framing the face. The tresses and curls could be tied back or flowing free and were adorned with a variety of natural or jeweled decorations, some of which came close to a diadem, but did not have the regal, stiff look of a tiara. Titian painted a sensual female lover in *The Three Ages of Men*, wearing a wreath of myrtle symbolic of everlasting love.

French society during Napoleon's reign (1799–1814) was inspired by a passion for classical aesthetics. With it, came a revival of the ancient fashion for diadems.

For his coronation in 1804, Napoleon wore a laurel wreath of golden leaves, each representing one of his victories. Made by the Parisian goldsmith Biennais after a design by the miniaturist Jean-Baptiste Isabey, it is alleged to have cost 8,000 francs. As Napoleon found the

wreath too heavy to wear, six leaves were removed just before the coronation.

Napoleon's Roman wreath of victory was plagiarized by society ladies and a new fashion was born. Hair-styles had a new, swept-up classical look, which was perfectly complemented by the Spartan diadem, a high, flat tiara, pointed at the front, embossed in gold and decorated with jewels. Empress Josephine, Napoleon's consort until her divorce in 1809, was painted on several occasions, wearing different Spartan diadems, which were also known as bandeaux.

Napoleon bestowed an even more elaborate and costly diadem to his new Empress, Marie-Louise, Archduchess of Austria. In order to mark the birth of their only son, the King of Rome in 1811, Marie-Louise was presented with a parure of jewels. The most valuable piece was a magnificent Spartan diadem encrusted with 1,500 diamonds, surrounding four large crown-jewel diamonds. The most valuable one at the front was the "Fleur-du-Pêcheur," a 25.53 carat stone from the collection of the Sun King's (Louis XIV) dynasty, ousted by the French Revolution. The diadem was designed and made by the Parisian jeweler F.R. Nitot, who charged the Emperor nearly one million francs.

### The British Royal Court

While Napoleon was indulging in the purchase of illustrious jewels in France, a succession of Hanoverian Kings in England contented themselves with hiring the jewels for each coronation and leaving the crowns stripped and bare during their reigns. The young Queen Victoria, the niece of George IV, made a decisive change to this practice. She not only ordered a permanent crown to be made, but also started a collection of priceless tiaras, still owned by members of the British Royal Family today.

The nineteenth century also affirmed a trend of bridal purity expressed in dress. In Britain, Queen Victoria preferred a demure wreath of orange blossoms to a golden royal tiara when she married her German cousin, Prince Albert, in 1840. Countless brides followed the style of the romantic young Queen, which was accentuated by a white veil, symbol of virginity and chastity. Queen Victoria, crowned at the age of eighteen, appreciated floral symbolism. Her favorite diamond diadem had motifs of roses, shamrocks, and thistles, symbolizing her sovereignty over England, Ireland, and Scotland. This famous coronation circlet, made by Messr Rundell with hired diamonds in 1820, had belonged to her uncle, King George IV. Victoria had it restored and set permanently with her own diamonds, thus making it one of the most important heirlooms of the British Royal family. The present Queen Elizabeth II is portrayed wearing it on a series of British postage stamps.

### The British Royal Collection of Precious Tiaras

The most splendid of all was the brilliant regal tiara especially made for Queen Victoria at the height of her

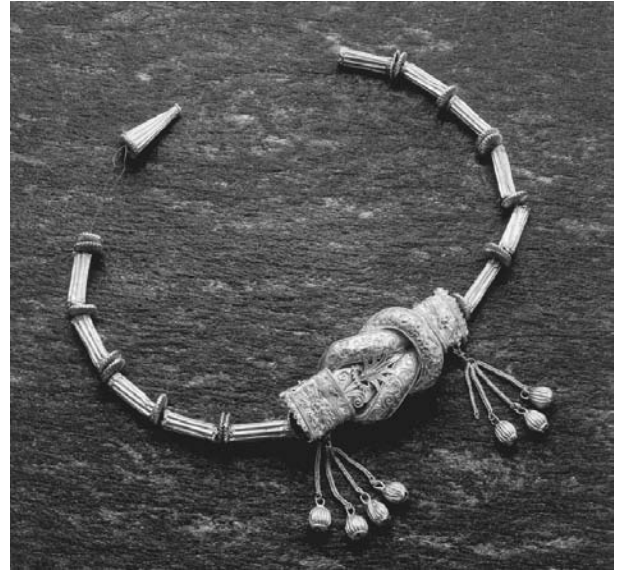

**Hellenistic tiara.** Herculean knots, or sailing knots, such as the one seen here, were often incorporated into the diadems of ancient Greece to save gold. © ARALDO DE LUCA/CORBIS. REPRODUCED BY PERMISSION.

reign in 1853. This diamond diadem, made by the royal jeweler Messr Garrard & Co, was to surpass all others in beauty and extravagance. Records in the company's ledger show that over 2,000 precious stones had been used to make this splendid tiara. The gems were set, forming a trellis framework around the central jewel, the most legendary of all diamonds, the Koh-i-noor or "Mountain of Light." This ancient, Indian diamond, weighing 186 carats, had been presented to the Queen by the Honorable East India Company after the Punjab fell under the rule of the British Crown in 1849. The five-thousand-year-old Koh-i-noor diamond was supposed to bring bad luck to all male rulers, but it had no such effect on Queen Victoria or on Queen Elizabeth, the Queen Mother, who had the stone reset into her own crown in 1938.

The regal Indian or opal tiara was also made for Queen Victoria in 1853. This oriental-style tiara was set with 2,600 diamonds surrounding seventeen large opals. Fifty years later, in 1902, Queen Victoria's daughter-in-law, Queen Alexandra, considered opals unlucky and had them replaced with eleven rubies, which had been a Maharajah's gift to her husband, the Prince of Wales, in 1875.

Another noteworthy diadem in the Royal Collection is the Scroll and Collet Spike Tiara, Queen Mary's wedding gift in 1911, affectionately known as "Granny's tiara." Made in 1893, this piece of jewelry has 27 graduating brilliants, all worked into a collet setting and topped by upstanding pearl spikes.

The Tear Drop Tiara is distinguished by its interlacing circles. Acquired by Queen Mary from the Russian



Imperial family in 1921, its large drop pearls, which can be exchanged with emeralds or other precious gems, are surrounded by circles set with diamonds. Queen Elizabeth II inherited this tiara when her grandmother died in 1953 and still wears it on state occasions.

The Hanoverian Fringe Tiara is dated 1830 and was a favorite of Elizabeth the Queen Mother. The brilliants are an heirloom from King George III and were mounted in a special way, so that the tiara could also be worn as a necklace. Princess Elizabeth wore it as a tiara on her wedding to Prince Philip in 1947.

Very similar in style is the Russian Fringe Tiara. Shaped like a Kokoshnik (the stiff halo-shaped peasant's headdress of Sythian origin), the tiara was presented to Princess Alexandra by a subscription of ladies of society on her Silver Wedding Jubilee, in 1888.

Queen Elizabeth, the Queen Mother, adored diamonds and pearls as much as Queen Victoria once did. As the young Lady Elizabeth Bowes Lyon, she was often photographed wearing a Bandeau Tiara, worn deep down over her forehead, fitting the 1920s style and fashion. In later years, as Queen Elizabeth, she preferred wearing her tiaras high, embedded in her hairstyle. One of her favorites was the so-called "Modern Tiara," made for her from South African diamonds that had been presented to King Edward VII by de Beers in 1901. This diadem was designed in the form of a complete symmetrical circlet with a fleur-de-lis at the center front. Made by the French jeweler Cartier in 1953, the pattern, with three rows of interlocking diamonds, forming diamond-studded hexagons, is easily recognizable.

Tradition dictated that aristocratic ladies were married wearing their family tiara and Lady Diana, choosing her family's Spencer Tiara, was no exception when she married Prince Charles in 1981. The Queen presented her with another precious diadem as a wedding present, the Bow Knot Tiara, which had been designed for Queen Mary in 1914. Designed by the royal jeweler Garrards of London, it had nineteen drop pearls, each encircled by diamonds. The top edge is decorated with a row of delicate diamond bows, representing lover's knots, a motif first used on rings by the Romans.

### Twentieth-Century Tiaras

During the twentieth century, Europe changed into a more egalitarian society, but, curiously, tiaras with their regal allure, survived. The turn of the century was a time of change and experimentation in all art forms, and jewelry was no exception. Art Nouveau and its parallel movement in Britain, called Arts and Crafts, evolved as a reaction to the Industrial Age of the previous century and aimed to restore the importance of individual craftsmanship. The Vienna Secession, founded by Gustav Klimt in 1897, was linked to the Wiener Werkstätten famous for art objects, including Jugendstil tiaras. The inspiration for many pieces of jewelry was based on a new discovery of nature,

expressed in a new, modern style. In Britain, Frederick Partridge (1877–1942), used cow's horn, rock crystals, and enamels for making his highly original and charming tiaras. René Lalique (1860–1945), a leading Parisian designer of jewelry of the same period, broke with traditional conventions of symmetry and designed charming tiaras inspired by trees, shrubs, and insects, using ivory, horn, and cast glass. He pioneered a new technique called *plique à jour*, a development from cloisonné enamel, which allowed transparency on leaves, petals, and insect wings.

Art Nouveau jewelry was prolific in Paris and contributed to the fashion for head ornaments in great diversity. Famous designers included Henri Vever, René Foy, and La Maison Boucheron, who all exhibited exquisite tiaras at the Exposition Universelle in Paris, in 1900. Fantasy was allowed to run wild and some headpieces were crafted in pierced gold lace and enameled peacock feathers. Jewelry and tiaras had attained the status of art rather than function, with many pieces too avant-garde and costly to find a buyer. Sadly, much was later taken apart and did not survive for posterity.

As fashion and couture established their power, many designers used tiaras to instill fantasy into their collections. Coco Chanel designed a whole range of tiaras in 1932 and adorned her models with comets and stars hung over their foreheads. The Duke of Westminster, who was a friend of Chanel, might have been inspired by her when he ordered a diamond tiara from the Maison Laclouche in Paris. It was to be a present to his fourth wife, Loelia, who set a new fashion by wearing this precious piece of Art Deco jewelry straight, from ear to ear, framing her face. The design had a strong Chinese influence with a detachable rivière necklace built in at the outer border.

In Britain, the coronation of King George VI in 1937 was a perfect catalyst for the ordering of new tiaras, and Cartier in Paris is said to have created 27 different Art Deco tiaras for this high-society event. The war years and the following decades of youth culture resulted in a decline of regal headdresses, but silver-screen film stars, such as Audrey Hepburn, kept glamour alive. She looked ravishing as a runaway princess wearing a tiara in Billy Wyler's film *Roman Holiday*, filmed in 1953, and again, as Natasha in Tolstoy's epic story *War and Peace*, filmed in 1955.

Ironically, the 1970s Punk rebellion brought tiaras back as fashion designer statements, notably reinvented by Vivienne Westwood, who is said to have been seen wearing her Italian coral diadem, bicycling around London. Westwood used tiaras on her celebrated catwalk shows, recreating ancient Spartan diadems as well as designing brightly colored plastic ones. The most original design, created in 1997 was a diamond-encrusted dog's bone with a bow, which might have been inspired by the love knots of the Victorian era.

Gianni Versace was a designer who celebrated glamour, and tiaras had to be included in his collections. In

1996, he won a de Beers Award with a diamond tiara, which was consequently worn by pop-star Madonna, who like many modern brides, might live their lives in jeans and T-shirts, but chose a regal style of dress for their wedding day.

Philip Treacy, London's top millinery designer, has created a number of modern tiara headpieces using metal, crystals, and feathers in his extravagant creative designs. He seems to be leading a number of artists and craftsmen, who like to express their creativity in tiaras, including Wendy Ramshaw, Jan Mandel, Jan Yager, and Viscount Linley (who, being a high-class carpenter, designed a wooden one). Many spectacular new designs were on show in London's Victoria & Albert Museum, in a special exhibition marking the Golden Jubilee of Queen Elizabeth in 2002.

The fashion of wearing precious tiaras has fluctuated with history and gone in tandem with society's appetite for egalitarianism or elitism, but it has not vanished. The downfall of many European monarchies might have diminished its importance, but curiously, the notion of elitism and the dream of being a princess, even for one day, has continued to seduce generations and the tiara has remained in fashion, in its classical styles as well as in new art forms.

### Outward Signs of Kingship

A crown is the most precious and important symbol of royalty. Usually made of solid gold and richly embellished with ornamental jewelry, a crown bestows power and status to kings, queens, and emperors. The basic circular design was derived from the earlier versions of fillets, circlets, and diadems. Some crowns are characterized by arches, which can be topped with a monde, a globular ornament under a "cross formée." Crowns, like diadems and tiaras, were often modified and redesigned for political or economic reasons, and so was the St. Edward's Crown, the oldest of all British crowns, that originated from the ancient Crown of England, dating back to the ninth century. Lined with a "Cap of State" of purple velvet, it weighs four pounds and is set with 440 gemstones. It is part of the collection of British Royal Crown Jewels kept in the Tower of London.

The "Reichskrone," or crown of the Holy Roman Empire, has an important political as well as a religious history. Also known as the Crown of Charlemagne, the legendary King of the Franks, crowned Roman emperor by the Pope in 752, it consists of eight gold plates decorated with precious gems and biblical images. As "Kaiserkrone des heiligen romischen Reiches deutscher Nation," it was in the possession of the Habsburgs from 1273 to 1806 and is still kept in the Imperial Schatzkammer in Vienna, Austria.

A more modern crown is the British Imperial State Crown, made in 1838 for Queen Victoria and worn by each British sovereign since. The gold, jeweled circlet

with four arches and topped with a monde and a "cross formée," is encrusted with one of the most valuable diamonds in the world, the Cullinan or "The Second Star of Africa," weighing 309 carats. In her later years, Queen Victoria developed a very personal and less ostentatious style and favored a miniature design of the large Coronation Crown. Perched high on her head with a lace veil draped down over her back, this silhouette of the Queen is the one easily recognized by future generations.

Coronets are smaller crowns worn by the British nobility of lower ranks. The highest and most important coronet belongs to the Prince of Wales, followed by various circlets for different members of the aristocracy. Their shapes and decorations follow a strict hierarchy. A Duke's circlet is adorned with eight strawberry leaves, a Marquess's has four strawberries and four pearls, an Earl's has eight pearled rays, alternating with eight strawberry leaves, a Viscount has sixteen pearls and a Baron has just six pearls. They are only worn on the ceremonial occasion of the coronation of a new sovereign.

See also **Jewelry; Royal and Aristocratic Dress; Wedding Costume.**

### BIBLIOGRAPHY

- Bury, Shirley. *Jewellery, 1789–1910: The International Era*, Vols. 1 and 2. New York: Antique Collector's Club, 1991.
- Menkes, Suzy. *The Royal Jewels*. London: Grafton Books, Collins Publishing Group, 1985.
- Munn, Geoffrey. *Tiaras, Past and Present*. London: Victoria & Albert Museum Publications, 2002.
- Newman, Harold. *An Illustrated Dictionary of Jewellery*. London: Thames and Hudson, Inc., 1981.
- Stopford, Francis. *The Romance of the Jewel*. London: Hudson and Kearns, 1920.

Susie Hopkins

**CUFF LINKS AND STUDS** A cuff link is a piece of jewelry that inserts into a buttonhole to fasten a shirt cuff around the wrist. Most commonly, cuff links come in pairs and consist of an ornamental head connected to a backing plate by a maneuverable link.

Studs consist of an ornamental head fixed to a protruding pin or knob; front and back connect using a detachable clasp. Akin to buttons, studs can fix permanently to a collar or shirtfront, or can be detached when desired. There are various methods of fastening available. Harold Newman describes five basic forms: the chain link, fastened to each head by a jump ring; the lentoid form, a backing head joined by a fixer bar to the ornamental head; the dumbbell, with one or both heads screwed into a vertical bar; the extension cuff, which conceals a retractable coil, thus allowing the shirtsleeves to rise to the elbow; and the snap lock, a simple press stud. Peter Hinks, as well as Eve Eckstein and Gerald Firkins, provide

illustrations of such mechanisms and information regarding original patents.

In the early nineteenth century, cuff links and studs became widely accepted accessories for any gentleman of taste. This emerging fashion paralleled the rise of the lounge suit (which appeared in the 1880s) and the white tailored shirt, which sported a turned-down collar and unfastened cuffs. Previously, men's shirts had stiff upright collars that required minimal fastening; extravagant bows or buttons fastened the cuffs. However, such ornate fashions did give way to uniform formality, this more somber attire required practical and discreet adornment. As such, men's jewelry became restricted to an ensemble of complementary pieces, made up of cuff links, studs, a tie or cravat pin, and buttons. These often came as a set—presented in a box or on a card—they tended to complement a gentleman's signet ring, fob watch, and chain. In essence, chromatic unity was the order of the day.

Initially, cuff links and studs were made of 15 to 18 karat gold; this indicated wealth and did not discolor the shirt. Round, square, or oval in shape, both pieces were often decorated with fine engraving, enamel work, or ivory. Sometimes small gems, pearls, or onyx were placed in the center of the head to add value. However, in the mid-to-latter part of the century, mass production revolutionized manufacture. Due to their simple design, cuff links and studs were perfect for bulk replication. As hand finishing was widely abandoned, 9 karat gold became the metal of choice. Consequently, compromised standards became the norm.

By the late 1800s, Birmingham was the center of all industrial enterprise. However, the production of cuff links and studs also occurred in the colonies, France, and the United States. Firms such as George West, Greaves' Patent, W. E. Riley and Sons, the French F. Moore, and the U.S.-based Baer and Wilde improved fastening technology and competed for a share of the lucrative accessory market. Accordingly, advertisements promoted function and style, longevity, and decorative appeal.

In the late nineteenth century, the Arts and Crafts movement advocated a return to handmade pieces, sparking a revival in the collection of quality items. However, mass production has prevailed and cuff links and studs remain popular unisex gifts. Their ability to convey affiliations and interests endures through the novelty of the ornamental head.

See also **Canes and Walking Sticks; Formal Wear, Men's; Jewelry; Neckties and Neckwear; Watches.**

#### BIBLIOGRAPHY

- Eckstein, Eve, and Gerald Firkins. *Gentlemen's Dress Accessories*. Buckinghamshire, U.K.: Shire Productions Limited, 2000. The original edition was published in 1987.
- Hinks, Peter. *Victorian Jewelry: An Illustrated Collection of Exquisite 19th Century Jewelry*. London: Portland House, 1991.

Marshall, Suzanne. *200 Years of American Manufactured Jewelry and Accessories*. Atglen, Pa.: Schiffer Publishing, 2003.

Newman, Harold. *An Illustrated Dictionary of Jewelry*. London: Thames and Hudson, 1981.

Joanne McCallum

#### CUNNINGTON, C. WILLETT AND PHILLIS

C. Willett (1878–1961) and Phillis (1887–1974) Cunnington were medical doctors with a general practice in North London in the 1930s; they were also major dress historians. C. W. Cunnington served in World War I as a captain in the Royal Army Medical Corps after graduating from Cambridge University. He married Phillis in 1918. The Cunningtons amassed a vast collection of English costume between the 1920s and the late 1940s, which they stored in a big shed in the garden of their house in North London.

Together they published on British dress history from the Middle Ages through the 1950s in their five *Handbooks of English Costume*, their *History of Underclothes*, and their *Dictionary of English Costume*, all published between 1951 and 1960. C. W. Cunnington also published his *English Women's Clothing in the Present Century* in 1952, while three of his earlier books, written between 1941 and 1948, elucidated his own theories about dress, fashion, and sexuality. He died in 1961.

The Cunningtons' famous handbooks mapped the development of styles of male and female dress. Each volume was illustrated with quotes from novels and newspapers of the period in question, and was illustrated by small line drawings as well as photographs of paintings. This approach paralleled and extended the work of German and French dress historians of the period as Oskar Fischel, Max von Boehn, and Maurice Leloir.

C. W. Cunnington's medical training influenced his primary interest, which was the psychological motives that he considered responsible for changes in women's dress styles in the late nineteenth century. Born in 1878, he would have been familiar with the bustles of the 1880s, the S-bend of the early 1900s, and the flat-chested boy-girl fashions of the 1920s. His interest in the psychosexual functions of women's dress had been enhanced by the 1930 publication of the psychiatrist John Carl Flügel's study, *The Psychology of Clothes*. James Laver, who was the Keeper of Prints and Drawings at the Victoria & Albert Museum as well as C. W. Cunnington's friendly rival for the leadership of British dress historiography, also took an erudite but more popular approach to similar themes in his book *Taste and Fashion* (1937).

C. W. Cunnington published five books on psychosexual themes in women's dress. His first was *Feminine Attitudes in the Nineteenth Century* (1935), followed by *English Women's Clothing in the Nineteenth Century* (1937),



*Why Women Wear Clothes* (1941), and *the Art of English Dress* and *The Perfect Lady* (both 1948). In *Feminine Attitudes* he used the fashionable middle-class Victorian garments he and his wife assiduously collected—which he called his “specimens”—as tools for studying “the psychological background of women,” and specifically their sexuality (1935, p. 2). Cunnington added that “we were concerned with mass psychology, not with the psychology of the individual” (Tozer, p. 3).

Cunnington diagnosed “the feminine mind through analysis of a series of ‘Attitudes,’ ... That is to say those unconscious postures of mind and body which members of a social group will display as features in common.” The attitudes that Cunnington listed included “the Conventional Attitude of those multitudes of mute, inglorious females ... who never did or said or thought anything that distinguished them from the mass of women of their day.” The “Feminine Attitude,” on the other hand, was influenced by the element of “sex attraction,” while “the Herd Instinct” was defined as “the wish to imitate in appearance and conduct those in the same social group.” Thus Cunnington showed that he shared Flügel’s view of the centrality of sexuality as a driving motivation in fashion development among women. For example, he saw the development of the 1870s bustle as inspired by the “mating instinct,” whereas that of the 1880s was inspired by the “maternal” instinct. He described the gait of Edwardian women, which he would have seen when he was in his mid-twenties, as “that provocative pelvic roll ... perhaps the most sensual Attitude of the century” (1935, pp. viii, 254, 306).

The first doubts about the accuracy of Cunnington’s opinions surfaced among women dress historians in 1949, when Doris Langley Moore wrote that she “had the strongest doubt that fashion . . . is motivated by sex appeal” (p. 21). Nonetheless, C. W. Cunnington’s reputation as a leading dress historian and theorist remained in place for a further thirty-seven years. In 1986, however, his work was subjected to a feminist reconsideration led by Jane Tozer, a curator at the Platt Hall, Manchester, Museum of Costume. While acknowledging the value of the Cunningtons’ famous handbooks for their details of style chronology, etiquette, and specific nomenclature, Tozer specifically targeted Cunnington’s “dated sexism,” denouncing it as a “simplistic and now outdated appraisal of the origins of human sexuality.” She also questioned Cunnington’s anecdotal approach as well as “his notorious vagueness” in naming sources in his books (pp. 11–12). Cunnington’s reputation was undoubtedly damaged.

Phillis Cunnington built on this critique, and later developed a more academic approach to dress history. She produced five meticulously researched specialist studies after her husband’s death: *English Costume for Sports and Outdoor Recreation* (1969); *Occupational Costume in England* (1967); *Costume for Births, Marriages and Deaths* (1972); *Costume of Household Servants* (1974); and *Charity*

*Costumes of Children, Scholars, Almsfolk, Pensioners*, published posthumously in 1978.

In addition to their published books, the Cunningtons made a major contribution to the study of fashion history through amassing their dress collection. Put together at a time when almost no one was collecting old garments, let alone late nineteenth- and early twentieth-century middle-class clothing, the Cunningtons’ collection has since become one of the most renowned in Britain. They sold it to Manchester City Council in 1947 to form the basis of the Museum of Costume at Platt Hall. The museum’s first curator was Anne Buck.

The Cunningtons were medical practitioners. They were not professional museum curators and undertook all their research unpaid if not unrewarded. They were interested in finding examples of “ordinary” people’s dress to use as general representations of garment types, which C.W. Cunnington then related to his typology of feminine attitudes. He had no interest in the owners of individual garments and felt no need to record their names or to provenance sources. Thus much of this information was lost or never recorded. It was left to Anne Buck and to later generations of curators to put this remarkable collection into order.

While C. W. Cunnington’s more theoretical comments have not withstood the passage of time, the handbooks he co-authored with his wife as well as Phillis Cunnington’s own work still offer a carefully compiled and useful introduction to the history of English costume. Publishing and collecting through the 1930s to the 1970s, at a time when fashion history still had no academic status and very little standing in museums, the Cunningtons educated the next generation of dress historians and curators who professionalized the field.

*See also Clothing, Costume, and Dress; Europe and America: History of Dress (400–1900 C.E.); Fashion, Theories of; Fashion Museums and Collections; Flügel, J. C.*

#### BIBLIOGRAPHY

- Cunnington, C. W. *Feminine Attitudes in the Nineteenth Century*. London: W. Heinemann, Ltd., 1935.
- . *English Women’s Clothing in the Nineteenth Century*. London: Faber and Faber, Ltd., 1937.
- . *Why Women Wear Clothes*. London: Faber and Faber, Ltd., 1941.
- . *The Art of English Dress*. London: Collins, 1948.
- . *The Perfect Lady*. London: Max Parrish, 1948.
- . *English Women’s Clothing in the Present Century*. London: Faber and Faber, Ltd., 1952.
- . *Looking Over My Shoulder*. London: Faber and Faber, 1961.
- Cunnington, C.W., and Phillis. *History of Underclothes*. London: Faber, 1951.
- . *Handbook of English Mediaeval Costume*. London: Faber and Faber, 1952 and 1973.

## CUTTING

- . *Handbook of English Costume in the Sixteenth Century*. London: Faber and Faber, 1954 and 1970.
- . *Handbook of English Costume in the Seventeenth Century*. London: Faber and Faber, 1955.
- . *Handbook of English Costume in the Eighteenth Century*. London: Faber and Faber, 1957.
- . *Handbook of English Costume in the Nineteenth Century*. London: Faber and Faber, 1959.
- . *A Dictionary of English Costume: 900–1900*. London: Adam and Charles Black, 1960.
- Cunnington, Phillis. *English Costume for Sports and Outdoor Recreation: From the Sixteenth to the Nineteenth Centuries*. London: Adam and Charles Black, 1967.
- . *Occupational Costume in England: From the Eleventh Century to 1914*. London: Adam and Charles Black, 1967.
- . *Costume for Births, Marriages and Deaths*. London: Adam and Charles Black, 1972.
- . *Costume of Household Servants: From the Middle Ages to 1900*. London: Adam and Charles Black, 1974.
- . *Charity Costumes of Children, Scholars, Almsfolk, Pensioners*. London: Adam and Charles Black, 1978.
- Jarvis, Anthea. "An Agreeable Change from Ordinary Medical Diagnosis, the Costume Collection of Drs. C. Willett and Phillis Cunnington." *Costume* 33 (1999): 1–11.
- Laver, James. *Taste and Fashion from the French Revolution Until Today*. London: George G. Harrap and Company, Ltd., 1937.
- Moore, Doris Langley. *The Woman in Fashion*. London: Batsford, 1949.
- Taylor, Lou. *Establishing Dress History*. Manchester, U. K.: Manchester University Press, 2004.
- Tozer, Jane. "Cunnington's Interpretation of Dress." *Costume* 20: 1–17.

Lou Taylor

**CUTTING** The Oxford English Dictionary notes that the first recorded reference to the word "tailor" was made in 1297. By that date, guilds for tailoring, weaving, and cloth merchants were well established in Europe.

Boyer (1996) outlines that the Renaissance period saw a change from the loose robe, formed from one or two pieces of fabric draped around the body, to garments that were constructed by methods of cutting and sewing to follow the contour of the human form. This period also witnessed a shift from "homemade" to artisan and craftsman constructed garments. The division of labor in this latter professionalized sphere was divided into that of the cutter and the tailor. The cutter would make a paper pattern and cut the fabric while the tailor would construct the garment using sewing techniques. These craft skills were seen as both art and science and jealously guarded.

### The Cutter

There have not been major changes in the process of cutting traditional tailored garments since the sixteenth century. The changes that have occurred have been more related to the mass-customization of tailored garments. There are still Master Tailors working today in Savile Row (London) and other major cities around the world who continue the traditional approach to tailoring methods and skills. It is in this world that the cutter may well advise the customer on their choice of cloth before taking the measurements, with a tape measure, writing down the figuration and style details that will form the worksheet for the finished product.

The cutter will meet the customer again when the garment is ready for the first fitting. The number of fittings can vary. Until relatively late in the twentieth century, it used to be as many as three, but today it is more often one fitting. The cutter "fits" the garment making adjustments using a series of chalk marks as instructions for recutting and for the tailor to follow to achieve a successful, well-fitting set of clothes. The cutter is responsible for producing the pattern, then marking and cutting the fabric. Sometimes an undercutter (striker) or apprentice will assist in this work.

### The Process

First the client is measured to access the figure type. Then a pattern is cut in a card or paper. The fabric is laid onto the cutting table and inspected for any defects. The pattern pieces are positioned to ensure economic use of the fabric. The pattern is marked using a white cake of chalk, and then manipulated for any changes in the client's figure. Then the inlays are marked (extra fabric above the seam allowance to allow for future adjustments). The trousers may be drafted directly onto the fabric without using a pattern.

This process could include the use of block patterns. These are a set of patterns previously produced by the cutter for general use across all sizes and adjusted to each client's measurements.

When the marking is complete, the fabric is cut using traditional tailor's shears. When all the parts are cut they are passed to the "trimmer," who will thread mark the seam lines using cotton thread and cut the linings and interlinings. The cut parts are then rolled into a bundle ready for the tailor.

The cutter's tools include: shears, tape measure, chalk, set square (wooden), and a ruler (wooden). There have been some innovations which include a change from a clear-linen to a printed-linen tape measure.

The cut and style of tailored garments are usually unique to the "house" or the company. The cutter will build a reputation for a particular style of cut. Earlier cutting methods involved cutting shapes that were recut after the fitting of the garment and copied onto card or paper to establish a pattern. These patterns were devel-

oped into block patterns for future use. This helped to move the process forward without having to return to the start point with each new client and/or garment. A library of patterns would then be built up.

### Training

The training of cutters usually followed a particular process: an apprentice would be assigned to a cutter. At first the apprentice would assist by learning to cut the canvases and pocket linings, working alongside the “trimmer.” The apprentice would assist the cutter with spreading and checking the fabric prior to marking. This would include sharpening the chalk and having the tools ready for the cutter. Other elements would include the “fetching and carrying” to assist the cutter.

Gradually the apprentice would learn skills and become an undercutter. At this stage the apprentice would be present when the client was measured to learn this procedure. The apprentice would eventually acquire his own clients and develop his own cutting style. This process would traditionally take approximately five years. Before the twelfth century until the mid-1800s, apprenticeships lasted seven years. Later on apprentice served five years followed by two years as an improver.

### Cutting Systems

The taking and recording of measurements is still under the ownership of the cutter and is often closely guarded. Before the mid-1800s the cutter usually used a plain white linen tape onto which he would write using hieroglyphics to keep the exact nature of the measurements and figuration strictly to himself. It has been recorded that other methods of measuring using leather, parchment, and paper (Wampen 1863) was used by early cutters. The introduction of the printed tape measure was an important step forward, which, along with more accurate pattern cutting, allowed for the sharing of information.

The system of cutting from direct measurements and adding tolerances (for example, half chest measure plus 2½ inches) continued until the mid-1800s. Cutting became more scientific from the early 1800s with publications, which included *The True Principles of Scientific Cutting* (Good, 1842). In his book *Mathematical Instruction Constructing Modes and Draping the Human Figure*, Wampen (1863) uses “anthropometry” as the basis for his measuring system and makes references to “proportional measure” for the cutting instructions. The written instructions follow an alphabetic code identifying body points as A, B, C, etc., and uses formulas, such as  $B' = 3u + u = 4u$ , rather than direct measurements. Reference is made by Humphreys (*Coat Cutting*, 1881) to using scales based on half the chest measure. He refers to “Graduation Tapes,” available from the “Tailor and Cutter” for cutting different sizes of garments. When the scale is used as a basis for cutting a jacket, it is based on half the chest measure—36 chest is an 18 scale. Differ-

ent body proportions are then calculated using the scale rather than taking a direct measurement.

The jacket as it is known today developed from the 1860s with the changes in lifestyle and transport. The lounge style of jacket developed in the early 1900s and an example is by the Tailor and Cutter Academy in the book by Vincent (*The Tailor and Cutter Academy Systems of Cutting Part 11*). The topics covered include the lounge jacket, use of the graduation square, figuration (shoulders, stance, etc.), riding jacket, and boy’s lounge. The Tailor and Cutter Academy were prolific in publications for the subject areas. This included a series named *The Cutters’ Practical Guide*, available in both full and pocket-sized editions.

### Pattern Technology

Pattern and garment engineering developed in the 1960s and has had an impact on the made-to-measure tailoring sector. The cutting systems are focused on the made-to-measure and mass-customization sectors of the menswear industry rather than the traditional tailoring sector.

Numerical cutting systems exist to draft patterns and cut directly onto fabric using laser, water jet, and mechanical (vertical and circular) cutting heads. These cutting methods are used and combined with traditional tailoring methods by the larger tailoring manufacturers.

The use of body scanning for both size surveys and cutting made-to-measure garments has developed during the 1990s, and research is ongoing with a number of industrial and academic collaborators. The process includes full-body scanning, recording information that builds the basis for individualized pattern construction. The linkage through CAD/CAM systems extends into cutting systems and interfaces with sewing systems for the assembly of custom garments.

*See also* Tailoring.

### BIBLIOGRAPHY

- Aldrich, Winifred. *Metric Pattern Cutting for Menswear*. Oxford: Blackwell Science, 1980.
- . *Metric Pattern Cutting for Menswear: Including Unisex Clothes and Computer Aided Design*. 3rd ed. Oxford: Blackwell Science, 1997.
- American Fashion Company, *American Garment Cutter*. 3d ed., 1914.
- Good, T. *The True Principles of Scientific Cutting*, London 1842.
- Humphreys, T. D. *Coat Cutting*. London: John Williamson, 1881.
- Modern Tailor, The. *Outfitter and Clothier*, 1936.
- Modern Tailor, The. *Outfitter and Clothier*. AA. White, London: Caxton, 1950.
- Morris, F.R. *Pocket Edition of the Cutters’ Practical Guide, Part One*. London: Tailor and Cutter, 1947.
- The Tailor and Cutter, April 20th 1876.



## CUTTING

Vincent, W.D.F. *The Tailor and Cutter Academy Systems of Cutting Part 11*. London: John Williamson, 1908.

Wampen, H. *Mathematical Instruction in Constructing Modes and Draping the Human Figure*. London: Messrs Boone, 1863.

The West End System of Cutting, 1895.

### *Internet Resource*

Boyer, Bruce G. *The History of Tailoring: An Overview*. 1996. Available from <<http://www.lone-star.net/mall/literature/tailor4.htm>>.

*Alan Cannon Jones*



**DAHL-WOLFE, LOUISE** Louise Dahl-Wolfe (1895–1989) was born in San Francisco. Aspiring to a career as a painter, she attended the California School of Design (now the San Francisco Art Institute), where she was greatly influenced by Rudolph Schaefer, known for his color expertise.

#### **Dahl-Wolfe's Early Career**

After completing her studies, Dahl-Wolfe designed electric signs from 1921 to 1923; in 1924 she began working for a leading decorator. In 1921 she was invited to the studio of photographer Anne Brigman; this meeting prompted her to buy her first camera, an Eastman bellows camera with a reflector made from a Ghirardelli chocolate box. She used her mother as the subject of her first pictures. Early photographic adventures included taking shots of herself and some friends nude on a beach, using the soft-focus style of her mentor. After Dahl-Wolfe befriended another San Francisco photographer, Consuela Kanaga, who taught her to use a 3¼-by-4¼-inch Thornton-Pickard English reflex camera with a Verito soft-focus lens, the two traveled together to Europe in 1927. While in Paris, Dahl-Wolfe bought a Pathé camera; in Germany she purchased a small film pack camera. On an excursion to Africa, she met Meyer (Mike) Wolfe, an artist from Tennessee, whom she subsequently married.

Dahl-Wolfe returned to San Francisco in 1928 and began taking commercial black-and-white photographs. Two years later, she and her husband spent a summer in a rented log cabin in the Great Smoky Mountains of Tennessee, where she began photographing still-life subjects and the local mountain people. She developed her film with a darkroom light powered by the battery of a Model A Ford. After moving with her husband to New York, Dahl-Wolfe was introduced to Frank Crowninshield, then editor of *Vanity Fair*, who decided to publish her work. The documentary pictures of her Tennessee subjects were a sensation when they first appeared in the November 1933 issue of *Vanity Fair*. This success led to the publication of her first black-and-white fashion work in *Harper's Bazaar* in 1936 and her first color work a year later.

#### **Dahl-Wolfe's Work in Color**

Dahl-Wolfe was one of the first and most important practitioners of fashion photography in color. Kodachrome

film came on the market for the first time in 1935, although the product at that time could not reproduce colors reliably either in the studio or in natural light. A striking aspect of Dahl-Wolfe's work was her color sensibility—a flawless instinct for combinations of colors. This emphasis on the painterly values of tone, line, and color is not surprising, since she had been trained as a painter and strongly influenced by the philosopher of art Clive Bell's theory of significant form. Bell maintained that color is an inherent part of the expressive quality of form and that arrangements of colors carry emotional weight—particularly bright luminous colors, which have a pleasing effect. Dahl-Wolfe's early training in color theory with the painter Rudolph Schaefer also influenced her interest in color photography. In order to achieve the exact effects she desired, she worked with the new eight-inch by ten-inch sheets of Kodachrome because they gave the highest degree of resolution and detail. She often consulted with the printers of the magazines she worked for in order to retain her subtly beautiful effects on the printed page.

Many of Dahl-Wolfe's photographs seem to be built up of colored planes rather than objects. Many of her shots for *Harper's Bazaar* are masterly combinations of compositional lighting, varied textures, repeated patterns, and a broad variety of shades, particularly earth-tone colors. For example, a simple black-and-white suit is seen through a darkened archway leading into a room of exotic warmth; in the room the model is the focal point within the mix of textures, patterns, and colors. The same natural light, here bounced through various screened patterns, is seen in another picture, where it filters through the organdy curtains in a room of lovely femininity and charm. The setting of this photograph was Louise Dahl-Wolfe's own bedroom in her home in Frenchtown, New Jersey, one of her favorite shooting locations. In addition to her pioneering use of color, she was also one of the first fashion photographers to make use of location shots, using architectural backgrounds and exotic locales to add interest to the way the clothing was pictured.

#### **Dahl-Wolfe's Importance**

Dahl-Wolfe's style—elegant yet casual, sophisticated yet at ease—was ideally suited for depicting the independent American woman, wearing comfortable ready-to-wear

styles by such American designers as Claire McCardell, Hattie Carnegie, and Norman Norell. Both the models and the clothes had a naturalness and authenticity that conveyed a cool and comfortable yet ineffably chic informality. This informality is perhaps the essence of Dahl-Wolfe's style: The models, the clothes, and the way she chose to portray them reflected the relaxed accessibility of a distinctly American fashion sense.

Dahl-Wolfe had a long and productive career as a fashion photographer. She worked for *Harper's Bazaar* for twenty-two years, from 1936 to 1958, leaving shortly after the magazine's editor Carmel Snow and its legendary art director Alexey Brodovitch resigned. Her career included eighty-six *Harper's* covers and over six thousand color photographs as well as thousands of black-and-white pictures. After leaving *Harper's Bazaar*, Dahl-Wolfe worked briefly for *Vogue* before finally retiring from professional photography in 1960.

See also **Fashion Magazines; Fashion Photography; McCardell, Claire; Norell, Norman; Vogue; Vreeland, Diana.**

#### BIBLIOGRAPHY

- Bellafante, Ginia. "What Dahl-Wolfe's Eye Created in a Lens." *New York Times*, 6 June 2000.
- Dahl-Wolfe, Louise. *Louise Dahl-Wolfe: A Photographer's Scrapbook*. Preface by Frances McFadden. New York: St. Martin's Press, 1984.
- Goldberg, Vicki, and Nan Richardson. *Louise Dahl-Wolfe: A Retrospective*. Foreword by Dorothy Twining Globus. New York: Harry N. Abrams, 2000.
- Hall-Duncan, Nancy. *The History of Fashion Photography*. New York: Alpine Book Company, 1979.

Nancy Hall-Duncan

**DAMASK.** See **Weave, Jacquard.**

**DANCE AND FASHION** The roots of the relationship between Western dance and fashion lay in the Renaissance period, where social dancing reflected the values of society. Dance as a channel of communication was as important as having the appropriate costume for socializing. After the French Revolution in 1789, professional ballet dancers left the Court spectacles in favor of the stage. From the beginning of the nineteenth century, the European ball culture emerged as a social activity and had an enormous impact on fashion and vice versa.

#### The Waltz Century

The nineteenth century was dedicated to the waltz, which had developed as a bourgeois activity in Europe and America. In *May I Have the Pleasure?*, Belinda Quirey argues that in the wake of political, romantic, and industrial revolutions, the waltz was a completely new dance



**Josephine Baker in banana costume.** Baker's revealing dance costumes caused much scandal and controversy, but her style also served as an inspiration for designers of mainstream fashion. HULTON ARCHIVE/GETTY IMAGES. REPRODUCED BY PERMISSION.

form that perfectly suited the new conditions of modern life—socially, psychologically, and materially. These nineteenth-century developments in dance were reflected in elaborate dance costumes for lower- and middle-class women, although upper-class ballroom-dance dresses were distinctively splendid for women. The *danse à deux* activity reinforced the pleasure of watching other people: how they harmonized and what they wore. Ballroom fashion was therefore an enormously important component of acceptance by polite society.

#### Tango Craze

Modern ballroom dancing began just before World War I, when dance halls flourished in Europe. The Hammer-smith Palais de Danse in London was among the first popular dance halls that provided an up-to-date program for modern ballroom dancing. Although the polka and the quadrille still remained very popular dance forms before the outbreak of World War I, the tango craze started and the fox-trot also became very fashionable. The origins of the tango lie in turn-of-the-century Argentina and





### ETIQUETTE HINTS FOR THE BALLROOM: DRESSED TO IMPRESS

Hillgrove's *Complete Practical Guide to the Art of Dancing* (1863) offers a vivid description of the importance of dress in the European ball culture:

Ladies should remember that men look to the effect of dress in setting off the figure and countenance of a lady, rather than to its cost. Few men form estimates of the value of ladies' dress. This is subject for female criticism. Beauty of person and elegance of manners in woman will always command more admiration from the other sex than costliness of clothing.

In another chapter, Hillgrove recommends that on entering a ballroom, all thought of self should be dismissed: "The pretty ambition of endeavoring to create a sensation by either dress, loud talking, or unusual behavior, is to be condemned." Not only the dress was im-

portant; society ladies had to take care of a fashionable hairstyle as well. In 1860, Florence Hartley recommends in *The Ladies' Book of Etiquette, and Manual of Politeness* that "one has to be very careful, when dressing for a ball, that the hair is firmly fastened, and the coiffure properly adjusted. Nothing is more annoying than to have the hair loosen or the headdress fall off in a crowded ballroom." Accessories played a key role in fashionable dressing for social ballroom events. Henry P. Willis advises in *Etiquette, and the Usages of Society* (1860) that "ladies should draw on their gloves (white or yellow) in the dressing room, and they should not have them off for one moment in the dancing rooms. However, at supper the gloves can be taken off, because "nothing is more preposterous than to eat in gloves."

emerged among European and African immigrants. Since earlier dances did not have the close body contact of the tango, this new dance was considered very risqué at the time. With its sensual rhythm and intense body contact, the tango had a distinctly sexual connotation. In fact, the tango was at first deemed so illicit that it was thought suitable only for prostitutes and their pimps. However, when the tango was legitimized and came to Europe, it was soon taken up by Parisian high society, and ballroom fashion had to be adapted to this new "sexual" dance form. Dance costumes were designed to be more tight-fitting and embellished with shiny paillettes and stones. Soon the tango dress style spread from cabarets and theaters to evening fashion. At the beginning of the twenty-first century, the cinema industry has picked up the tango fashion in scenes of cult films such as *Moulin Rouge*.

#### Josephine Baker: A Black Pearl

In her 1920s' performances in "barely there" dresses, Josephine Baker shocked Parisian society with her display of naked skin. In the following decade, she became famous not only for her style of performing but also for her stage costumes: her elaborate headdresses and banana costume received standing ovations at the Folies Bergère. Although her look was considered vulgar, her dresses served as a source of inspiration for fashion in the 1920s and 1930s. Josephine Baker gave shape to a new culture, which liberalized fashion and dance to a new era of evening dresses.

#### Hollywood Screen Dancing

In the late 1920s, screen dancing became popular, and Hollywood style spread from the screen to day and

evening fashion. The lightweight Charleston dress, with its long fringes, became part of the Roaring Twenties lifestyle. Anne Massey describes in *Hollywood Beyond the Screen* that the films *Our Dancing Daughters* in 1928, and *Our Modern Maidens* in 1929, represent the debut of the art deco style reflected in architecture and fashion. In the 1930s, Fred Astaire and Ginger Rogers were the source of inspiration for fashion-oriented cineastes in movies such as *Top Hat* (1935), and *Swing Time* (1936). The Hollywood culture and its concept of glamour advanced the Americanization of dance culture, which in turn influenced the fashion scene. During the harrowing Great Depression, dance marathons, with their emphasis on nonstop endurance for the entertainment of the masses, became popular in social dance clubs. Fashion companies advertised at these events to promote club fashion.

#### Lindy Hop: Swinging Parties

In 1926, the Lindy hop craze started at the Savoy ballroom in Harlem, New York. In the early 1930s, high society was interested in seeing Lindy hop performers entertain at parties. The resulting swing-dance fashion became popular: cotton blouses with fitted waists and puffed sleeves combined with an A-line skirt—sometimes with detachable suspenders to give maximum hold—for female Lindy hoppers, and high-waisted pants with matching fitted vests for their male counterparts. The Savoy style spread quickly over to Europe, and the Lindy hop and its fashions were adopted by the London and Parisian elites.

#### Broadway Dreams

In the 1940s, the evolution of dance on film had a crucial influence on the whole world of dance. The pre-

dominantly working-class audience was getting real Hollywood value for little money in the cinemas of the 1940s. Those who could afford musical theaters enjoyed the pleasure of live performances on Broadway. With the advent of television in the 1950s and movie theater attendance drastically down, financially strapped Hollywood studios turned to film adaptations of successful Broadway shows, as this was a more economical option than developing original screenplays. Film makeup and clothes of Broadway shows had a strong influence on everyday fashion. Department stores such as Bullocks in Los Angeles became the place where both Los Angeles inhabitants and foreign visitors bought their musical dance-inspired wardrobe. Later on, such Broadway shows as *West Side Story* (1957), a modern-day retelling of *Romeo & Juliet*, had a lasting influence on the American teenager, who copied the Broadway look.

#### From Rock and Roll to Saturday Night Fever

In the 1950s, the postwar generation brought a new form of dance into the nightclubs. Rock and roll—derived from African American rhythm and blues—and stars such as Elvis Presley and Bill Haley immortalized the image of the rebellious teenager and also influenced fashion and hairstyles well into the 1960s. Social dance moved away from couple dancing, and new freedom was expressed in checked shirts and tight-fitting denim jeans for young men, while teenage girls wore petticoats and backcombed their hair. By the end of the 1960s, a particular dance form no longer existed, and young people moved their bodies to the music in whatever way they wanted. The disco scene emerged and exerted a crucial influence on the fashion world. DJs combined records, encouraging dancers to stay on the floor for a long period. Fashion designers took advantage of the *en vogue* disco style and immortalized dance film stars such as John Travolta in *Saturday Night Fever* (1977). His white disco suit in the movie acquired iconic status, establishing disco as part of mainstream culture until the 1980s, when the public had lost its interest in it, and punk and new wave style challenged its dominance.

#### Street Style: Hip-hop, Break-Dancing, and Techno

In the early 1980s, hip-hop culture gained a mass appeal when black and Hispanic DJs evolved the use of backbeats in New York City and Los Angeles clubs. Break dancing and hip-hop were very athletic styles, often mimicking robotic movements, and therefore required a more casual clothing style. Sport brands such as Adidas, Nike, and Puma flourished among street-style dancers. During the following decade, the house music style developed from hip-hop and brought alive a new generation of club culture, and club fashion became less casual. In the late 1980s, the rave scene emerged. Rave represented more than a dance party; it illustrated a physical and mental state, unifying the club dancers. Melissa Harrison's *High Society: The Real Voices of Club Culture* offers a detailed description of the rave phenomena. Rave accessories such

as glow-in-the-dark-jewelry and clothing with utility bags became very important.

#### As Seen on Screen: Music Video Style

In the mid-1980s, music stars such as Michael Jackson and Madonna based their performances on dance, and revolutionized the power of music videos. In concept, music videos were based on song, choreography, special effects, and fashion, which was widely copied among club-goers. With the emergence of boy bands, girl bands, and teenage music groups at the beginning of the 1990s and their promotion through videos, a new generation was influenced by the music stars. Mainstream fashion was strongly influenced by performers such as Backstreet Boys, Spice Girls, Take That, Britney Spears, and Justin Timberlake, who pioneered and set up fashion trends, such as tank tops, low-cut jeans, very conspicuous and ostentatious gold jewelry for both male and female teenagers, and “visible” underwear for girls. At the start of the twenty-first century, music performers created a mixture between club style and contemporary dance while using the medium of fashion to create a celebrity style, which became an essential part of the music and dance industry.

See also **Dance Costume; Film and Fashion; Music and Fashion; Theatrical Costume.**

#### BIBLIOGRAPHY

- Dodd, Craig. *The Performing World of the Dancer*. London: Bresslich & Foss, 1981.
- Driver, Ian. *A Century of Dance: A Hundred Years of Musical Movement, from Waltz to Hip Hop*. London: Hamlyn Octopus Publishing Group Ltd., 2000.
- Jonas, Gerald. *Dancing—The Power of Dance Around the World*. BBC Books: London, 1992.
- Harrison, Melissa. *High Society: The Real Voices of Club Culture*. London: Judy Piatkus Ltd., 1998.
- Hartley, Florence. *The Ladies' Book of Etiquette, and Manual of Politeness*. Boston: 1860.
- Hillgrove, Thomas. *A Complete Practical Guide to the Art of Dancing*. New York: Dick & Fitzgerald, 1863.
- Massey, Anne. *Hollywood beyond the Screen: Design and Material Culture*. London and New York: Berg Publisher, 2001.
- Silvester, Victor. *Modern Ballroom Dancing*. London: Stanley Paul & Co. Ltd., 1993.
- Quirey, Belina. *May I Have the Pleasure?: The Story of Popular Dancing*. British Broadcasting Corporation: London, 1976.
- Willis, Henry P. *Etiquette, and the Usages of Society*. New York: Dick & Fitzgerald, 1860.

Thomas Hecht

**DANCE COSTUME** The relationship between dance and dance costumes is complex and does not simply reflect dance practice in a specific period, but also social behavior and cultural values. Dance costumes can be

divided into the following categories: historical, folk or traditional, ballroom, modern, and musical dance costumes. Influence has spread from fashion to dance and back again.

### Historical Dance Costumes

From the fifteenth to the eighteenth century, festivities at European courts required highly elaborate dance costumes. The style of court dance costumes tended to be similar to everyday dress of the period, incorporating, for example, laced corsets, puffed and slashed sleeves, farthingales with skirts and applied decoration. In the early twenty-first century, the reproduction of historical dance costumes was evident in the activities of historical dance organizations, such as the Institute for Historical Dance Practice (IHDP) in Ghent, Belgium.

### Folk-Dance Costumes

From the fifteenth century onward, folk dance developed steadily in Europe. The field of European folk-dance costumes is very complex, as each of the country's regions has its own dances, dress, and customs. Eastern European folk dances, such as czardas, mazurkas, and polkas, soon spread to England and France. Folk-dance costumes re-

flected the East European look in the use of bright colors on dark backgrounds. Costumes were often highly decorated with beads, metal, and silk threads. The basic women's dress was a short, light-colored chemise and a petticoat, over which several layers of fabric were worn. A draped headdress indicated the marital status of the wearer (fancy headgear indicated that the girl was unmarried). European folk dance formed the basis for square-dance activities. European settlers who came to America introduced this special type of country dance and its costume first in New England, but before long, square dance started to spread across the country. Evening dress was the standard outfit for dancers: ankle-length hooped skirts for the women and formal jackets for men. During the following two centuries, the cultural mix of European settlers in America has led to a variety of national folk-dance costumes. Farmer and cowboy dance wear were mainly based on components of everyday clothing: shirts, cotton trousers, and cowboy boots for men, and ankle-long cotton gingham dresses for women. The minuet, polka, waltz, and quadrille via France and England brought more elaborated dance costumes to America: tailored long-sleeve shirts and trousers in a Western-cut style for male dancers and full floral-embroidered skirts



**Dancers in unitards.** These one-piece garments are typically made from spandex or a similar stretchy, pliable fabric, giving the dancer nearly unlimited range of motion. © JULIE LEMBERGER/CORBIS. REPRODUCED BY PERMISSION.



and blouses for females. Accessories such as Western belts, string ties, or silk kerchiefs completed the square-dance outfit.

In the late 1990s, high-end designers such as Dolce & Gabbana, Roberto Cavalli, and Miu Miu had created an “urban cowboy look” with Western-inspired dress embellished with floral patterns on such articles of clothing as tuxedo shirts and jeans, as well as traditional pointed-toe cowboy boots.

In the early 2000s, amateur and professional female square dancers often wear double-swirl skirts with alternating ruffles in the fabric and wide white lace. The lace is used on bodice and sleeves, and an appliqué and bow are sewn on the fitted midriff. Male square dancers wear cowboy-style shirts with scarf tied around the collar, high-pocket jeans, and sometimes a cowboy hat. Pants cuffs are usually worn inside the cowboy boots. The United Square Dancers of America (USDA) booklet, *Square Dance Attire*, is probably the best resource for the history of square-dance costumes.

### Belly-Dance Costumes

Oriental, or belly, dance originates from snakelike movements provided by the sisters of a woman giving birth as

they tried to inspire her to deliver the baby. In 1893, belly dance was brought from the Arabic world to the United States on the occasion of the Chicago World’s Fair. Exotic-colored fabrics embroidered with semiprecious stones, paillettes, and beads are characteristic of the style. Semitransparent tops with fringes reveal the stomach and navel while brassieres and wraparound skirts swing rhythmically to the beat of Middle Eastern music. Coin belts and hip scarves are an essential part of the belly-dance outfit. Sometimes belly dancers cover their face with a veil, especially when the dance is performed by a male dancer (cross-dressing). Alternatively, shoulder-to-floor-length beaded and sequined tunics over harem pantaloons are worn. Historically, evidence points to the crucial influence of Islamic Orientalism in European fashion during the twentieth century, starting with the French designer Paul Poiret’s use of the tunic shape and updating old-fashioned styles with exotic harem pants and veils wrapped around the body in the 1920s. In the 1990s, the prêt-à-porter and haute couture collections of Western European and American designers, such as Miguel Adrover, Jean Paul Gaultier, John Galliano, Alexander McQueen, and Rifat Ozbek, have been influenced by Oriental belly-dance costumes. Nancy Lindis-



**Greek folk dancers.** While traditional Greek costumes vary from island to island, some similarities can be found, such as basic construction, the use of certain fabrics, and head coverings such as those seen here. © GAIL MOONEY/CORBIS. REPRODUCED BY PERMISSION.



### PROFESSIONAL AND AMATEUR BALLROOM DRESS

#### ***Tango dress:***

Usually one piece with a tight-fitting top and a swinging bottom slit high to reveal the leg. Stretch materials are used to guarantee a tight silhouette. The dance dress is often highly decorated with rhinestones, beadings, glitter and paillettes.

#### ***Swing and Latin dress:***

Very similar to tango dresses, but the much shorter hemline makes the dress more sexual and can reveal the complete leg. Animal prints such as tiger or leopard intensify the wild connotation of these dresses.

#### ***Waltz and fox-trot dress:***

Elegant one-piece dress often made in expensive light-weight silks or satins. A wide-swinging, ankle-length style intensifies the soft movements of these dances.

#### ***Charleston dress:***

The necessary freedom of movement was guaranteed by knee-length shirt-dresses embroidered with glass beads and paillettes. The light weight of the dress and long fringes made it swing rhythmically according to the movements of the dance, which was part of the lifestyle of the Roaring Twenties and became the most popular

American dance in Germany and Europe; thanks in great part to Josephine Baker, who gave performances in 1927 with her Charleston Jazz Band in Berlin.

#### ***Polka and mazurka dress:***

Folkloric traditional dress with colorful print design and usually a peasant blouse and a wraparound skirt embellished with opulent frills and garlands. During the 1970s, peasant blouses became very fashionable in everyday clothing, and high-end designers such as Emilio Pucci designed ethnic-style garments with embroideries and frills. Floral peasant blouses with soft ruffled hems had a revival in the late 1990s when designer brands such as Yves Saint Laurent, Dolce & Gabbana, Moschino, and Christian Dior created a folkloric fashion theme.

#### ***Rumba and samba dress:***

With contrasting ruffles on the skirt and sleeves, this dress is often designed in a Caribbean style with bright colors.

#### ***Cha-cha dress:***

A two-piece dress with a tight-fitting top and a wide off-the-shoulder neckline, while the skirt is full and flounced at the bottom. Rhinestones are usually attached to the fabric to give a glamorous effect.

farne-Tapper's *Languages of Dress in the Middle East* is a detailed source about Middle Eastern dress in both the ancient and the modern world.

### **Ballroom-Dance Costumes**

From the early nineteenth century, ballroom dances were taken up by a broad public, and special evening dresses were designed to fit these occasions. The waltz, fox-trot, polka, mazurka, and Viennese waltz required an elegant style. By the twentieth century, dance costumes for the tango, swing and Latin, Charleston, rumba, bolero, cha-cha, mambo, and samba were more erotic.

### **Modern-Dance Costumes**

At the beginning of the twentieth century, Isadora Duncan's natural movements on stage characterized a new era for dance. Duncan's modern dance style has been influenced by Greek art, folk dances, social dances, and athleticism. Free-flowing costumes and loose hair permitted a great freedom of dance movement. After World War I, modern-dance groups emerged with predominantly female dancers. During the following decades, avant-garde choreographers, such as George Balanchine and Martha

Graham, and later Merce Cunningham, Paul Taylor, Alvin Ailey, and Pina Bausch, reformed and liberalized traditional dance and its costumes. Moving away from traditional ballet techniques, modern dance gave rise to a new era of costuming. Costumes and makeup took on a unisex look as choreographers felt it less relevant to differentiate female and male dancers. Theater designers experimented with seminude costumes: transparent T-shirts and short black trunks for men and simple bodices and plain tights for women were the standard outfits.

In 1934, neoclassical dance choreographer George Balanchine was the first to dress ballet dancers in rehearsal practice clothes for public performances. The use of noncolors characterized Balanchine's costumes, which were almost always black and white. His sense for minimalism on the stage developed through the revealing of nudity.

Martha Graham was one of the first to promote dance without pointe shoes on stage. In *Diversion of Angels* (1948), she dressed female dancers in draperies, and men were almost naked. Isamu Noguchi-inspired special crowns and hat pins by Graham became particularly famous as part of the modern-dance costume. Newly in-

vented cuts made skirts and dance dress appear like trousers, permitting a great freedom of movement. At the beginning, Graham's dances were performed on a bare stage, which underlined the minimalism she demonstrated in the costumes. Later on, she also replaced the traditional ballet tunics of male dancers and the folk dress and tutus of female dancers with straight, often dark and long shirts or rehearsal leotards. Awarded the Medal of Freedom in October 1976, Martha Graham was the first dancer to receive that distinction.

In the 1950s, costumes of Balanchine- and Graham-oriented contemporary dance choreographers, such as Merce Cunningham and Paul Taylor, tended to continue an emphasis on the seminude style, though prints on leotards personalized the individual contemporary dance style and its costumes. In 1958, the artist Robert Rauschenberg created shiny silky tights speckled with rainbow dots for Cunningham's *Summerspace*. The designs of choreographer and costume designer Alwin Nikolais influenced the contemporary stage with performances such as *Noumenon Mobilis* (1953) and *Imago* (1963).

### Musical-Dance Costumes

Evidence of musical theatres date to the eighteenth century when two forms of this song-and-dance performance emerged in Britain, France, and Germany: ballad operas, such as John Gay's *The Beggar's Opera* (1728), and later on comic operas, such as Michael Balfe's *The Bohemian Girl* (1843). At this time, many plays had short runs, and



### MEN IN TIGHTS: THE MALE DANCER

In Russia, male dancers are highly regarded, and usually classical ballet training is the basis for a career in dance. Though a growing interest in dance exists among boys in other countries, many are too shy to take dance lessons and be obliged to wear tights, commonly considered a female article of clothing. Therefore, certain dance schools allow young male students to practice in T-shirts and short pants. Under the practice clothes, dancers usually wear suspensories, designed to isolate and support the testicles. Alternatively, a dance belt, specialized underwear, can be worn under tights. In both cases, the pouch in front is triangular, tight, and nearly flat to give support and form during dance moves. The subject of masculinity in dance has received popular treatment in such movies as *The Children of Theatre Street* (1977) and *Billy Elliot* (2000). Ramsay Burt's book *The Male Dancer* explores the subject of masculinity in dance in greater depth.



### TAP-DANCE SHOES: FAMOUS SOUNDS

The origins of tap dance, a style of American theatrical dance with percussive footwork, lie in slave dances in the southern states that incorporated African movement and rhythm into European jigs and reels in the early nineteenth century. Tap dance was adopted in theaters from 1840, and clogging in leather-soled shoes became more and more popular. At the fin-de-siècle, turn of the century, two different styles of tap-dance shoes had been established: stiff wooden-sole shoes, also called buck-and-wing, made popular by the duo Jimmy Doyle and Harland Dixon, and soft leather-sole shoes popularized by George Primrose. In the 1920s, metal plates (taps) had been attached to leather-sole shoes, which made a loud sharp sound on the floor. In the 1940s and 1950s, dancers such as Fred Astaire, Paul Draper, and Gene Kelly popularized tap shoes to a wider audience through the medium of Hollywood films.

stage costumes were often based on everyday-dress design. In the late 1880s, comic operas conquered Broadway in New York, and plays, including *Robin Hood*, were designed for popular audiences. From the 1880s until the 1920s, the musical-comedy genre in London emerged, and designers such as Lady Duff-Gordon, known as Lucile, elaborated fashionable costumes for singers and dancers. In the early 1920s, tap-dance techniques were popularized and specially designed tap-dance shoes were available on the open market.

In the fifties, musicals such as *My Fair Lady* (1956) surprised the audiences with numerous costume changes. Costume designer Cecil Beaton had created costumes enhancing the transformation of Eliza, the main character, from a common flower vendor into a society lady. In 1975, Michael Bennett's *A Chorus Line* opened on Broadway, and aerobic and dance outfits became popular on stage and in everyday life. Bright neon shades in pink, green, and yellow dominated the range of colors. Dance tights, leggings, headbands, and wristlets spread from stage to fashion and vice versa. In 1988, the musical *Fame*, inspired by the movie and TV series, opened in London and reflected the fashion of the eighties, showing leotards and shorts. At the beginning of the twenty-first century, A. R. Rahman's Bollywood musical *Bombay Dreams* (2002) opened in London, and its Indian costumes demonstrated the ethnic influence on stage design.

See also **Dance and Fashion; Ballet Costume; Music and Fashion; Theatrical Costume.**



## BIBLIOGRAPHY

- Balasescu, Alexandre. "Tehran Chic: Islamic Head Scarves, Fashion Designers and New Geographies of Modernity." *Fashion Theory* 7 (2003): 1.
- Buonaventura, Wendy, and Ibrahim Farrah. *Serpent of the Nile: Women and Dance in the Arab World*. Northampton, Mass.: Interlink Publishing Group, 1994.
- Burt, Ramsay. *The Male Dancer: Bodies, Spectacle, Sexualities*. London and New York: Routledge, 1995.
- Carter, Alexandra. *The Routledge Dance Studies Reader*. London and New York: Routledge, 1998.
- Dodd, Craig. *The Performing World of the Dancer*. London: Breslich & Foss, 1981.
- Lindisfarne-Tapper, Nancy, and Bruce Ingham. *Languages of Dress in the Middle East*. Surrey: Curzon, 1997.
- Strong, Roy, Richard Buckle, and Ivor Guest. *Designing for the Dancer*. London: Elron Press Ltd., 1981.

*Internet Resources*

- Education Committee of the United Square Dancers of America, Inc. *USDA Booklet B-018*. USDA Publications, 1997. Available from <<http://www.usda.org>>.
- Institute for Historical Dance Practise (IHDP) 2004. Available from <<http://www.historicaldance.com>>.

Thomas Hecht

**DANDYISM** Walter Benjamin, in his treatise *Charles Baudelaire*, writes: "The dandy is a creation of the English" (p. 96). If dandyism, the style and the practice, is a uniquely English construct, it was the French who defined it in prose and poetry. The French author Jules Barbey D'Aureville, in his 1845 essay "Du dandysme et de George Brummell," described it as a nationally characteristic mode of vanity combined with "the force of [an] English originality . . . as profound as her national spirit." The dandy's dandy, George Bryan "Beau" Brummell, captured in the turn of his cuff and the knot of his cravat the studied irony and languor that defined his age. At the height of his popularity, from 1799 to 1810, Brummell, the son of a minor nobleman, held the entire British aristocracy in his sway. Attracted to no one particular feature of character (Brummell was neither great poet nor eminent thinker), his admirers were ostensibly captivated by his urbane sangfroid and impeccable dress, a clever and consummately constructed package that aimed to "astonish rather than to please" (Walden, p. 52). Essentially Brummell's philosophical stance was to stand for nothing in particular, a posturing that aptly crystallized the uncertainty of a period that witnessed the decline of aristocracy and the early rise of democratic politics. Sartorially, he refined a mode of dress that adopted English country style in a renunciation of the affectations of Francophile fashion (ironically so, if one considers that these very fripperies have become so linked to the dandyism of contemporary imagination). As the dress historian James Laver, writing in 1968,

points out, "whatever else it was, [dandyism] was the repudiation of fine feathers" (p. 10).

If Brummell was considered oppositional, it was in the privileging of this country clothing for wholly urban pursuits. Not an innovator (Thomas Coke of Norfolk was the first of the nobility to present himself in court in "sporting" attire over half a century previously), Brummell merely encapsulated and reflected back to society the sentiments of the times. In the early 1800s, the "sporting costume" of the English nobility reflected the increase in time spent supervising their estates; a top hat and tails in sober tones, linen cravats, breeches, and sturdy riding boots were a uniform of practicality and prudence. That Brummell appropriated this style for promenading through London's arcades and holding court at one of the many gentlemen's clubs of which he was a member served a dual purpose—suggesting the validity of entertainment as the "occupation" of the leisured classes while eradicating any immediate visible difference in status between himself and the "working" man.

In his recorded witticisms and his style, Brummell appeared to contemplate no distinction other than taste. His preoccupation with pose and appearance was derided as the last gasp of aristocratic decadence, but in many ways he anticipated the modern era—a world of social mobility in which taste was privileged above birth and wealth. Elevated as a style icon, he presaged the contemporary dominance of fashion and celebrity; clothing is as powerful a tool now as it was two hundred years ago for conveying new social and economic directions. Dedicated to perfection in dress (his lengthy toilette was legendary) and the immaculate presentation of his body, Brummell's total control over his image finds its legacy in twenty-first-century masculine dress styles.

**Dandyism in France**

Dandyism was a potent cocktail that swiftly endeared itself to England's European neighbor, France (and much later to Russia), privileging a love of beauty in material goods while appearing to nod to the revolutionary sentiment of the times. Most notable of France's dandies was the young Alfred Guillaume Gabriel, count d'Orsay. Only a teenager when dandyism first crossed the seas to Paris, d'Orsay's sartorial power had risen to Brummellian heights by 1845.

Unlike Brummell, however, d'Orsay's pursuit of dandyism was a search for personal fulfillment rather than social power. Already powerful by token of birth, d'Orsay's legacy was of dandyism as fashion plate, and he became known as the original "butterfly dandy." There was also none of Brummell's austerity; the French imagination had already mixed dandyism with English romanticism, as evidenced in d'Orsay's more sensual, lavish, and luxurious approach to dress—silk replaced linen, curves replaced stricter lines, gold for silver. That much of France's dandy traditions grew from literary interpretation

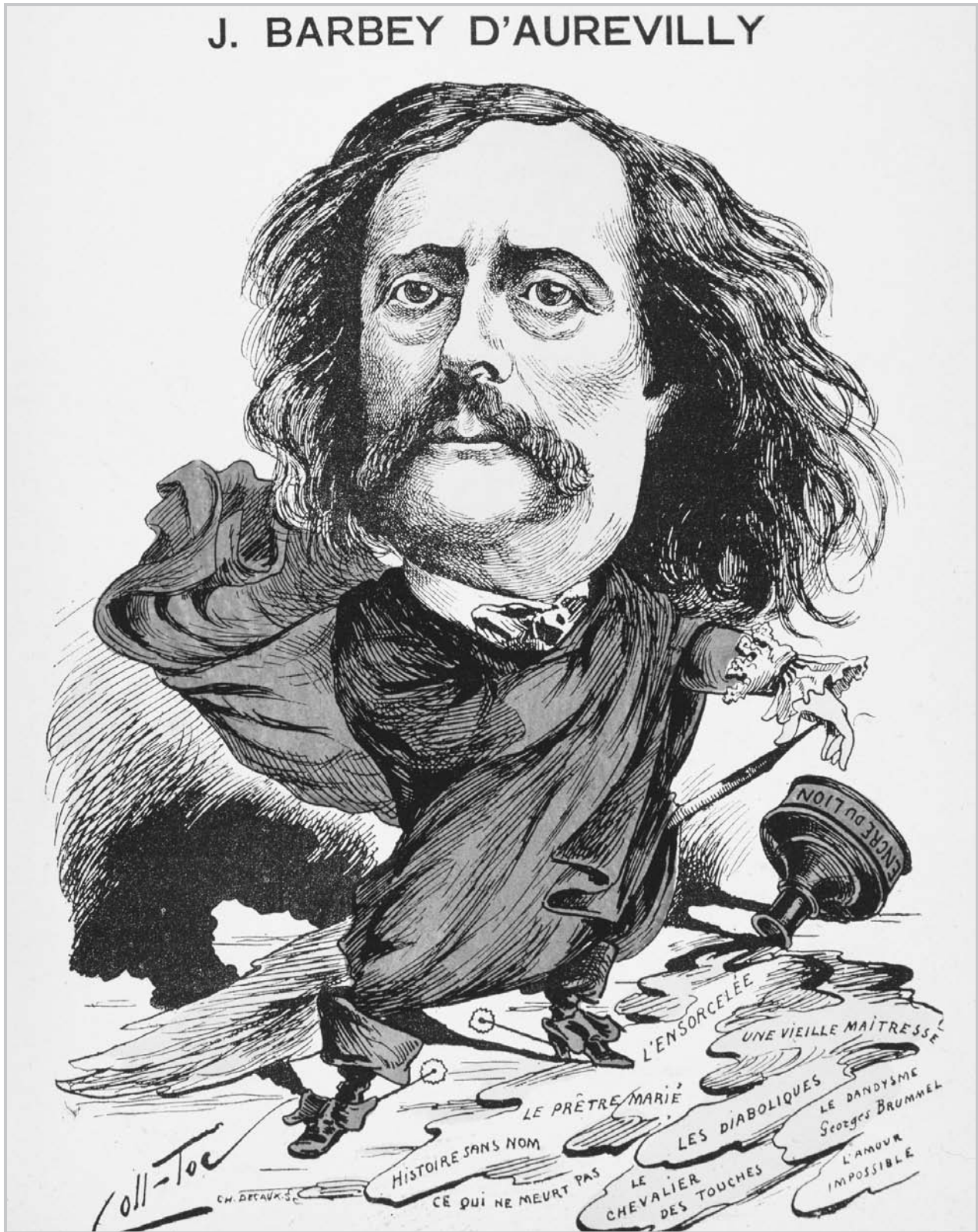

Illustration of French author Jules Barbey d'Aureville. D'Aureville was a major force in defining dandyism in a positive way, placing more emphasis on the dandy's intellectual pursuits and bohemian spirit than on his clothing. © LEONARD DE SALVA/CORBIS. REPRODUCED BY PERMISSION.



is important in the context of the development of dandyism into a moral and artistic philosophy.

### Dandy Philosophy

Defining dandyism is a complex task, and few writers have done so more successfully than Lord Edward Bulwer-Lytton in his treatise on the dandy of 1828, *Pelham; or, The Adventures of a Gentleman*. Considered at the time to be a manual for the practice of dandyism, it amply demonstrates the growing link between the promotion of the self and promotion through the social ranks. Notable maxims include: “III: Always remember that you dress to fascinate others, not yourself,” and “XXIII: He who esteems trifles for themselves is a trifler—he who esteems them for the conclusions to be drawn from them, or the advantage to which they can be put, is a philosopher” (pp. 180–182).

That Bulwer-Lytton associates dandy practice with philosophy was concordant with later literary movements such as Barbey D’Aurevilly’s toward enshrining dandyism as intellectual pose rather than fashionable consumption. More immediately, however, *Pelham* inspired a Victorian backlash against dandyism that was to define the 1830s. At around the same time as d’Orsay reached the peak of his influence, back in England William Makepeace Thackeray was releasing the serial of his novel *Vanity Fair*, at the venerable age of thirty-six. Thackeray had contributed significantly to the Victorian approbation of dandyism in the 1830s, epitomized by the views expressed in Thomas Carlyle’s *Sartor Resartus* [The tailor retailed] (1838). Thackeray’s regular columns and later novels, *Vanity Fair* and *The History of Pendennis*, were vivid representations of the moral and religiously driven belief that dandyism was a shallow and louche behavioral deficiency but they ironically were informed by his association with, and enjoyment of, the company of dandies such as d’Orsay.

It was the French, in particular D’Aurevilly, that were to define dandyism, through literature, as a positive practice and “robust moral philosophy” (Beward, p. 3). D’Aurevilly’s *Du dandyisme et de Georges Brummell* had a profound influence on all the texts, British and French, that followed it. Although D’Aurevilly never met Brummell, he formed an intimate friendship with Guillaume-Stanislas Trébutien, a scholar and native of Caen, the provincial French town to which Brummell escaped following his indebtedness and ultimate disgrace in the English court. Trébutien met and befriended William Jesse, a young officer who had in turn met Brummell at a social event in Caen and was impressed with Brummell’s “superlative taste.” Jesse’s accounts of Brummell, relayed to D’Aurevilly through Trébutien, were to form the basis of D’Aurevilly’s text. Jesse was to broaden D’Aurevilly’s already significant knowledge of dandyism, Regency literature, and the history of the Restoration, which formed the background to the practice by introducing him to more obscure texts that would never have

reached the shores of France. D’Aurevilly was a little known author and poet prior to *Dandyisme* and found it hard to find a journal willing to publish his text. Consequently he and Trébutien decided to publish it themselves, further driven by the notion that a book on dandyism should be, anyway, an “eccentric, rare and precious” (Moers, p. 261) object.

D’Aurevilly, for the first time, celebrated dandyism and dedication to pose as a distinction. Dress, while important, was relegated to second place behind D’Aurevilly’s emphasis on the “intellectual quality” of Brummell’s position. As Ellen Moers points out in her seminal text *The Dandy*, “Barbey’s originality is to make dandyism available as an intellectual pose. The dandy is equated with the artist; society thus ought to pay him tribute. Brummell is indeed the archetype of all artists, for his art was one with his life” (p. 263).

The understanding of dandyism as an artistic presentation of the body related to the single-minded pursuit of bohemian individuality was developed thoroughly in the writings of Charles Baudelaire. Baudelaire was not that interested in Brummell, but more in the modernity, as he saw it, of the ideas that he expressed. Baudelaire saw in Brummell’s dandyism the elevation of the trivial to a position of principle that perfectly mirrored, and offered an ideal framework for, his own beliefs. Baudelaire and D’Aurevilly maintained close contact through the 1850s and 1860s, exchanging letters, books and ideas about the practice. It was primarily through D’Aurevilly’s writings that Baudelaire’s bohemian dandy philosophy was made clear, although Baudelaire’s one essay on the subject *Le peintre de la vie moderne* later came to define Baudelaire’s approach to the subject. As Moers suggests, D’Aurevilly’s text on Brummell was so definitive as to liberate Baudelaire to “reach for the Dandy whole, as a symbol in the poetic sense” (p. 276).

Baudelaire’s view of dandyism as an “aristocracy superiority of [the] mind . . . [a] burning desire to create a personal form of originality” (Benjamin, p. 420), was taken up by the Aesthetic movement as a righteous crusade, a veneration of beauty and abhorrence of vulgarity that was defined by the Oxbridge scholar Walter Pater and, later, the decadent aestheticism of Oscar Wilde. Wilde’s earlier interpretation of dandyism took little from Brummell’s original aesthetic, influenced as his style was by the material tactility and medieval styling of the period (he later threw off the aesthetic-inspired costume in favor of a more somber style). What appealed to Wilde was the idea of beauty and perfection as expressed through the body and dress—the cultivation of the person as an art form that Baudelaire had crystallized in *La vie moderne*. Like Brummell (and Honoré Balzac, the Victorian-era dandy Benjamin Disraeli, and the Parisian aesthete Count Robert de Montesquiou-Fezensac), Wilde promoted himself and his work through the presentation of his public body and quickly rose to the top of Britain’s social circle as a result. The era of decadence



was the apogee of dandy performance in a world that was increasingly dominated by “advertising, publicity and showmanship,” in front of a far greater audience than Brummell could ever or would have wished to envisage. Wilde’s performed individuality and flamboyant costume were shackled to his desire for notoriety.

Like other notable dandies of the period, Aubrey Beardsley, Max Beerbohm, and James McNeill Whistler, Wilde also looked upon dandyism as a refuge from and bulwark against the burgeoning democracy of the times (although the dandyism of the fin de siècle was fueled by new money in a way that the Regency elitists would have decried). Although Wilde believed, hoped, that aestheticism would prevail, he was perhaps more accurate with his comment that London society was “made up of dowdies and dandies—The men are all dowdies and the women are all dandies.”

### The Female Dandy

The emergence of the female dandy was to coincide with the downfall of Oscar Wilde. In Joe Lucchesi’s essay “The Dandy in Me,” he cites the American artists Georgia O’Keeffe and Romaine Brooks as notable female dandies of the period along with Brooks’s London-based circle of friends—in particular the aristocrat Lady Troubridge, the British artist “Peter” Gluck, and the writer Radclyffe Hall. By the 1900s, dandyism had reached New York, with O’Keeffe and her circle drawing on Baudelaire’s dandy philosophy “to make of oneself something original” (Fillin-Yeh, p. 131). Certainly Brooks’s adoption of the dandy code was conscious; she noted that “They [her admirers in her London circle] like the dandy in me and are in no way interested in my inner self or value” (Fillin-Yeh, p. 153).

Brooks’s dandyism was bound up in her lesbian sexuality. The sartorial lexicon of dandy practice offered these women a model for negotiating a social position for themselves that shared signifiers with the dress of the modern woman. Joe Lucchesi writes that “lesbians adopted the signifying dress of the modern woman as a way of expressing their sexuality yet also linking it to a similar but less dangerous figure” (Fillin-Yeh, p. 173).

As Virginia Woolf was to note in *A Room of One’s Own* (1929), the woman’s position within the sphere of cultural production was still difficult to carve out in what was a male-dominated community. It seems to be no coincidence that Woolf’s shape-shifting *Orlando* ultimately takes on masculine form in the character’s twentieth-century incarnation. Baudelaire had suggested that lesbians were the “heroines of modernism . . . an erotic ideal . . . who speaks hardness and mannishness” (Benjamin, p. 90), and for Brooks and her circle, there was a direct link between the invisibility of the female artist and the invisibility of female homosexuality. The figure of the dandy, certainly following Wilde, united concerns of the self as art form, the feminized homosexual, and the position of the individual within the urban environment.

Inspired by her compatriot and friend James McNeill Whistler, Brooks’s dress shared many similarities with his (and de Montesquiou-Fezensac’s) gentlemanly elegance and refined creativity. Although the fashions of Brooks’s portraits were already thirty years out of date for men, they emerged in parallel with the notion of the modern, heterosexual woman and the modernity of Gabrielle “Coco” Chanel. Masculine dress, within the fashion arena, served to emphasize the sexualized and idealized female physique in the same way that it had always done for the male body. In addition, it offered a means for women like Chanel, who went from country girl to courtesan to milliner to designer to affect a revolution in their social status and representation. Drawing inspiration from masculine, aristocratic sporting clothing, Chanel understood as deftly as Brummell its practical and social value. As Rhonda K. Garelick writes, “By casting off the complicated frill of women’s clothing and replacing them with solid colours, simple stripes and straight lines, Chanel added great visual ‘speed’ to the female form, while granting an increased actual speed to women who could move about more easily than before” (Fillin-Yeh, p. 41).

### Contemporary Dandies

The figure of the dandy provides an abundance of material for the subversive and frequently ironic interventions that have come to be associated with British cultural production. Throughout the twentieth century, periods of acute social upheaval have witnessed parallel and intense bursts of dandy behavior. Masculine consumption, and the relationship of material goods to class and status, have played an important role for social and cultural arrivistes from Noel Coward and Cecil Beaton in the 1920s and 1930s to the publisher Tyler Brûlé and the designer Ozwald Boateng in the 1990s. “And,” as writer George Walden suggests, “English sensitivities are acutely alive to anything to do with social nuance, whether accent, posture, conduct or clothes” (Walden, p. 29).

The desires of Regency dandyism were amply catered for by a plethora of specialist boutiques that had grown up in and around the streets of London’s Mayfair and Piccadilly. The tailors; breeches, boot, and glove makers; milliners; and perfumiers that vied to tend to the immaculate bodies of their dandy customers were sandwiched between numerous specialists catering to the refined tastes of their client’s stomach, interior décor, and cultural entertainment and welfare. The consumerism of the Regency dandy makes him a particularly analogous figure to the contemporary British dandies of the late twentieth and twenty-first centuries. Moving beyond the golden triangle to Carnaby Street in the 1960s, and latterly Islington, Spitalfields, and Hoxton Square, the sites of dandy consumption are, for the most part, reassuringly familiar—small, select boutiques, elite tailors, exquisite restaurants and bars, exclusive members clubs, artisan publishers, and celebrity delicatessens still dominate the dandy landscape.

In the twenty-first century, the steady spread of globalization, of branded culture, is once again providing fertile ground for the emergence of the contemporary dandy. The figure of the dandy presents a sartorial and behavioral precedent that allows for the celebration of beauty in material culture while cultivating an aura of superiority to it, and the early twenty-first century has seen a resurgence of interest in the traditional purveyors of material status. London's Savile Row is increasingly populated by filmmakers, recording artists, visual artists, and designers, joining the existing ranks of the traditional British gentleman who is these tailors' staple client. At the same time, brands such as Burberry, Aquascutum, and Pringle, who have traded for decades on their status as suppliers of quality and standing, have seen their customer profile alter to include an international audience in search of distinction as well as a more specific sartorial subculture closer to home—the Terrace Casual.

The early 1980s Casual project was vehemently patriotic. Forays into Europe in the early 1980s showed Britain's football fans in stark contrast to their Italian and French counterparts whose immaculate dress prompted a revolution in British working-class style that saw the football fan become the principle consumer of mostly European luxury sporting brands. Today's Terrace Casual springs from similar terrain. What separates him from his forebears is that the garments he favors are principally British, the upper-class sporting pursuits which with they are associated redolent of the masculine camaraderie and corporeal engagement of club life favored by Brummell and his circle. As with Brummell, the Terrace Casual style is engaged in the positioning of traditional upper-class "country" style in the urban environment, co-opting it for the pursuit of leisure rather than the management of rural estates. While adopting the trappings of aristocracy disrupts perceived social status, it acts as a celebration rather than rejection of all the mores and moralities that these garments imply.

Oscar Wilde once said, "One should either be a work of art, or wear a work of art," and Hoxton style is the ultimate expression of the "music/fashion/art" triumvirate that characterizes British street style in the twenty-first century. As Christopher Breward writes, "D'Aureville's dandy incorporated a spirit of aggressively bohemian individualism that first inspired Charles Baudelaire and then Joris-Karl Huysmans in their poetic celebrations of a sublime artificiality . . . It is possible to see this trajectory leading forward through the decadent work of Walter Pater and Oscar Wilde to inform . . . twentieth century notions of existential 'cool'" (Breward 2003 p. 3). While Wilde's bohemian decadence runs like a seam through the Bloomsbury set; the glam-rock outrage and rebelliousness of Jimi Hendrix, Mick Jagger, and David Bowie; the performativity of Leigh Bowery and Boy George; and the embodiment of life as art in Quentin Crisp, it is the Hoxton Dandy, as epitomized by the singer Jarvis Cocker, who presents an equally subversive con-

temporary figure. Originality is as crucial for the Hoxton Dandy as it was for Brummell and Hoxton Square, once a bleak, principally industrial quarter of East London, now at the heart of a trajectory of British bohemianism that began in Soho in Brummell's time. Hoxton has quickly become a hub of new media/graphic/furniture/fashion design style that embraces its gritty urban history of manufacturing. Artisan clothing has often drawn upon dress types more usually associated with the workingman in order to emphasize the masculinity of artistic pursuit, the physical labor involved in its production. This is no less true of the Hoxton style, which is rooted in a flamboyant urban camouflage—a mix of military iconography, "peasant" staples, and industrial work wear, made from high-performance fabrics whose functionality always far outweighs their purpose.

In his time, the modernity of Brummell's monochromatic style marked him out in opposition to more decadent European fashion and made him a hero to writers such as Baudelaire. Modernism in the twentieth century continued to struggle to establish itself as a positive choice in British design culture, yet the periods of flirtation with clean lines and somber formality were intense and passionate, a momentary reprieve from the ludic sensibilities British designers more commonly entertained. The early British Modernists of the 1950s sought to emulate the socially mobile elements of American society. Stylistically, they drew inspiration from the sleek, sharp, and minimal suit favored by the avant-garde musicians of the East Coast jazz movement. Philosophically, early mods saw themselves as "citizens of the world" (Polhemus 1994 p. 51), a world in which it only mattered where you were going, not from where you came. In 2003 clean lines and muted colors once more afforded relief from the riot and parody of postmodernism that had dominated British fashion since the emergence of Vivienne Westwood and, latterly, John Galliano. The Neo-Modernist style draws, as it did in Brummell's day, on established sartorial traditions but subverts them through materials (denim for suits, shirting fabrics for linings), form (tighter, sharper, and leaner than the norm) and, ultimately, function.

Brummell was, in fact, almost puritanical in his approach to style. Max Beerbohm wrote in the mid-twentieth century of "the utter simplicity of [Brummell's] attire' and 'his fine scorn for accessories,'" which has led contemporary commentators such as Walden to note that "Brummell's idea of sartorial elegance, never showy, became increasingly conservative and restrained" (Walden, p. 28). Aesthetically, British gentlemanly style is the closest to Brummellian dandyism. As in previous centuries, the gentleman is defined by class and by his relationship to property (rural and urban). This easy, natural association reflects the apparent effortlessness of dress, manners, and social standing. Gentlemanly dress is loaded with expressive, but never ostentatious, clues; as Brummell suggested, "If [the common man] should turn . . . to look at

you, you are not too well dressed; but neither too stiff, too tight or too fashionable.” Brummell’s refusal of finery for a more practical costume can be seen in the contemporary confinement of his own style of cravat, frock coat, and highly polished boots to special-occasion wear. In this, the early twenty-first-century gentlemanly uniform of gray or navy suit, black lace-up shoe, white shirt, and modestly colorful tie more than nods to Brummell’s stylistic approach.

See also **Benjamin, Walter; Brummell, George (Beau); Europe and America: History of Dress (400–1900 C.E.); Fashion, Historical Studies of; Fashion and Identity; Wilde, Oscar.**

#### BIBLIOGRAPHY

- Balzac, Honoré de. *Sur le dandysme. Traité de la vie élégante. Par Balzac. Du dandysme et de George Brummell par Barbey D'Aurevilly. La peinture de la vie moderne par Baudelaire. Précédé de Du délire et du rien par Roger Kempf.* Paris: Union générale d'Édition, 1971.
- Barbey d'Aurevilly, Jules. In *Du dandysme et de George Brummell.* Edited by Marie-Christine Natta. France: Plein Chant, 1989.
- Benjamin, Walter. *Charles Baudelaire: A Lyric Poet in the Era of High Capitalism.* Translated by Harry Zohn. New Left Books, 1973. Reprint, London: Verso, 1997.
- Breward, Christopher. *The Hidden Consumer.* Manchester, U.K.: Manchester University Press, 1999.
- . “21st Century Dandy: The Legacy of Beau Brummell.” In *21st Century Dandy.* Edited by Alice Cicolini. London: British Council, 2003.
- Bruzzi, Stella, and Pamela Church Gibson, eds. *Fashion Cultures.* London: Routledge, 2000.
- Evans, Caroline, and Mina Thornton, eds. *Women and Fashion.* London: Quartet, 1989.
- Fillin-Yeh, Susan, ed. *Dandies: Fashion and Finesse in Art and Culture.* New York: New York University Press, 2001.
- Garellick, Rhonda. *Rising Star: Dandyism, Gender, and Performance in the Fin de Siècle.* Princeton, N.J.: Princeton University Press, 1998.
- Laver, James. *Dandies.* London: Weidenfeld and Nicolson, 1968.
- Lucchesi, Joe. “The Dandy in Me.” In *Dandies: Fashion and Finesse in Art and Culture.* Edited by Susan Fillin-Yeh. New York: New York University Press, 2001.
- Lytton, Edward Bulwer. *Pelham; or, Adventures of a Gentleman.* London and New York: G. Routledge and Sons, 1828.
- Mason, Phillip. *The English Gentleman: The Rise and Fall of an Ideal.* London: Deutsch, 1982.
- Moers, Ellen. *The Dandy: Brummell to Beerbohm.* London: Secker and Warburg, 1960.
- Polhemus, Ted. *Street Style.* London: Thames and Hudson, Inc., 1994.
- Walden, George. *Who's a Dandy?* London: Gibson Square Press, 2002. Includes a translation of Jules Barbey D'Aurevilly's “Du dandysme et de George Brummell.” 1845.

Alice Cicolini

**DASHIKI** A dashiki is a loose-fitting, pullover shirt usually sewn from colorful, African-inspired cotton prints or from solid color fabrics, often with patch pockets and embroidery at the neckline and cuffs. The dashiki appeared on the American fashion scene during the 1960s when embraced by the black pride and white counterculture movements. “Dashiki” is a loanword from the West African Yoruba term *dansbiki*, which refers to a short, sleeveless tunic worn by men. The Yoruba borrowed the word from the Hausa *dam ciki* (literally “underneath”), which refers to a short tunic worn by males under larger robes. The Yoruba *dansbiki*, a work garment, was originally sewn from hand-woven strip cloth. It has deep-cut armholes with pockets below and four gussets set to create a flare at the hem. Similar tunics found in Dogon burial caves in Mali date to the twelfth and thirteenth centuries (Bolland). In many parts of West Africa today such tunics of hand- or machine-woven textiles (with or without sleeves and gussets) are worn with matching trousers as street clothes. In the 1960s, the dashiki appeared in the American ethnic fashion inventory, along with other Afrocentric clothing styles, possibly from the example of African students and African diplomats at the United Nations in New York (Neves 1966). A unisex garment, the American dashiki varies from a sleeveless tunic to the more common pullover shirt or caftan with short or dangling bat sleeves. Both sexes wear the shirt, and women wear short or full-length dashiki dresses.

#### Dashiki as American Fashion

In the United States the term “dashiki” entered American English circa 1968 (*Merriam-Webster's Collegiate Dictionary* 2000). Following the Civil Rights Act of 1964, the popularity of Afrocentric clothing grew along with pride in racial and cultural heritage among Americans of African descent. First worn as an indicator of black unity and pride, the dashiki peaked in popularity when white counterculture hippies, who “set the tone for much of the fashion of the late sixties” (Connikie, p. 22), included the colorful shirts and dresses in their wardrobes. The aesthetics of mainstream male fashion shifted toward the ethnic, men began to “emulate the peacock,” and the dashiki became trendy by the end of the 1960s. Worn by increasing numbers of young white Americans attracted to the bright colors and ornate embroidery, the dashiki lost much of its black political identity and epitomized the larger scene of changing American society. By the late 1960s, American retailers imported cheap dashikis manufactured in India, Bangladesh, and Thailand. Most of these loose-fitting shirts and caftans were sewn from cotton “kanga” prints, a bordered rectangle printed with symmetrical bold colorful designs, often with central motifs. Kanga prints were introduced in the nineteenth century by Indian and Portuguese traders to East Africa, where in the early twenty-first century women still wore them as wrappers (Hilger, p. 44). Contemporary kanga, manufactured in Kenya and Tanzania, was discovered by African American fashion designers in the 1960s (Neves



1966) and was ideal for the simply tailored dashikis. One kanga-patterned dashiki with chevron, geometric, and floral motifs became a “classic” and was still manufactured in the twenty-first century.

### Dashiki as Symbol

Throughout its history in American fashion, the dashiki has functioned as a significant, but sometimes ambiguous, identity marker. In its earliest manifestation, with the Afro hairstyle, headgear, and African beads, it was associated with black power, the “Black Is Beautiful” movement, and the development of Afrocentrism. The historian Henry Louis Gates Jr. recalls, “I remember very painfully those days in the late sixties when if your Afro wasn’t 2 feet high and your dashiki wasn’t tri-colored, etc., etc., then you weren’t colored enough” (Rowell, p. 445). Initially, the garment had strong political overtones when “dashiki-clad cultural nationalists . . . typified the antithesis of the suit-and-tie integrationists” (Cobb, p. 125). Political activists such as Huey P. Newton and Stokely Carmichael of the Black Panthers Party sometimes combined the dashiki with the black leather jacket, combat boots, and beret that identified the militant group (Boston, pp. 204–209). However, the dashiki never gained a clear militant identity in the African American community. Leaders of the more moderate wings of the Black Civil Rights movement, such as Jesse Jackson and Andrew Young, sometimes wore dashikis to project a distinctive Afrocentric look as they promoted the more peaceful goals of Martin Luther King Jr. (Boston, p. 67). As the dashiki grew popular with African Americans as a symbol of cultural pride, it gained metaphorical significance in black activist rhetoric. The educator Sterling Tucker stated, “Donning a dashiki and growing a bush is fine if it energizes the wearer for real action; but ‘Black is beautiful’ is dangerous if it amounts only to wrapping oneself up in one’s own glory and magnificence” (Tucker, p. 303). The Black Panther Fred Hampton wore dashikis but declared, “we know that political power doesn’t flow from the sleeve of a dashiki. We know that political power flows from the barrel of a gun” (Lee).

### Dashiki in the Twenty-first Century

In the early days of the twenty-first century, the dashiki has retained meaning for the African American community and a historical marker of the 1960s counterculture. While seldom seen as street wear, the dashiki is worn at festive occasions such as Kwanzaa, the annual celebration to mark the unity of Americans of African descent and express pride in African heritage (Goss and Goss). A 2003 Internet search called up over 5,000 entries for “dashiki,” largely from marketers who offer a range of vintage or contemporary African clothing. Vintage clothing retailers market dashikis as “a must for all hippie freaks” and for “wannabe hippies.” Costume companies offer “the dashiki boy” with a classic dashiki shirt, Afro wig, dark glasses, and a peace pendant necklace. Purveyors of African clothing have expanded the meaning of dashiki



**Stevie Wonder wearing a dashiki.** South African president Nelson Mandela escorts singers Kenny Latimore and Stevie Wonder at his Johannesburg home in 1998. Although the dashiki’s popularity as everyday-wear waned after the 1960s, some African Americans continue to wear dashikis to festive occasions and as a symbol of pride in their African heritage. AP/WIDE WORLD PHOTOS. REPRODUCED BY PERMISSION.

beyond the distinctive shirt to include a variety of African robe ensembles and caftan styles. The dashiki’s popularity as a street style has faded, but it continues as an integral part of the African American fashion scene for festive occasions and as a form of dress evocative of the lifestyle of 1960s America.

See also **African American Dress; Afrocentric Fashion.**

### BIBLIOGRAPHY

- Bolland, Rita. “Clothing from Burial Caves in Mali, 11th–18th Century.” In *History, Design, and Craft in West African Strip-Woven Cloth*. Washington, D.C.: National Museum of African Art, 1966, pp. 53–82.
- Boston, Lloyd. *Men of Color: Fashion, History, Fundamentals*. New York: Artisan, 1998.
- Cobb, William, Jr. “Out of Africa: The Dilemmas of Afrocentricity.” *The Journal of Negro History* 82, no. 1 (1997): 122–132.
- Connikie, Yvonne. *Fashions of a Decade: The 1960s*. London: B. T. Batsford, Ltd., 1998.
- De Negri, Eve. “Yoruba Men’s Costume.” *Nigeria Magazine* 73 (1962): 4–12.
- Giddings, Valerie L. “African American Dress in the 1960’s.” In *African American Dress and Adornment: A Cultural Perspective*. Edited by Barbara M. Starke, Lillian O. Holloman, and Barbara K. Nordquist, pp. 152–155. Dubuque, Iowa: Kendall/Hunt Publishing Company, 1990.
- Goss, Linda, and Clay Goss, eds. *It’s Kwanzaa Time!* New York: G. P. Putnam’s Sons, 1995.
- Hilger, Julia. “The Kanga: An Example of East African Textile Design.” In *The Art of African Textiles: Technology, Tradition and Lurex*. Edited by John Picton, pp. 44–45. London: Barbican Art Gallery/Lund Humphries Publishers, 1995.

## DEBUTANTE DRESS

Lee, Paul. "From Malcolm to Marx: The Political Journey of Fred Hampton." *Michigan Citizen*, 18 May 2002.

Neves, Irene. "The Cut-up Kanga Caper." *Life* (16 September 1966): 142–44, 147–8.

Rowell, Charles H. "An Interview with Henry Louis Gates, Jr." *Callaloo* 14, no. 2 (1997): 444–463.

Tucker, Sterling. "Black Strategies for Change in America." *The Journal of Negro Education* 40, no. 3 (1971): 297–311.

*Norma H. Wolff*

**DEBUTANTE DRESS** Once restricted to young women from wealthy families on the social register, the traditional long, white formal dress and opera-length kid gloves of the debutante are more and more frequently also worn by daughters of the middle class. Cultural variations, such as the Hispanic *quinceañera*, not only introduce a young woman into society but also reinforce ethnic identity. While making a debut no longer necessarily signifies that the deb is looking for a husband—the age of a debutante ranges from fifteen to the mid-twenties—it is still a rite of passage denoting adult status socially.

### Development of Debuts

The term "debut," to enter into society, is French in origin but became familiar to English speakers during the reign of King George III (1760–1820) when Queen Charlotte began the practice of introducing young aristocratic women at court. From 1837 on, they were called "debutantes," later shortened to "debs." The Lord Chamberlain's Office developed strict regulations regarding proper dress for court presentations. From 1820 to 1900, ladies wore fashionable evening dresses, a mandatory headdress of veiling and feathers plus a train attached first at the waistline and, in later years, at the shoulders. Long, white kid gloves, bouquets, or fans were often added (Arch and Marschner 1987). In the United States of the early nineteenth century, elite families gave relatively small parties to introduce their marriageable-age daughters to their friends and to single men of appropriate age and status.

After the Civil War and the emergence of new wealth based on industry and railroads, the parties began to grow into lavish balls as old and new wealth vied with one another for status. One party featured an artificial lake with a large papier-mâché swan that exploded on cue, sending hundreds of roses into the air. American debutantes wore full evening dress but did not add the headdresses and trains of their English counterparts. White became standard for English debs by the end of the nineteenth century while American girls could also choose a color, as long as it was a very pale pastel. Male escorts wore formal evening wear, either tails or tuxedos, just as in the early twenty-first century. As an alternative to the private parties, exclusive social clubs, usually all male, were formed in the nineteenth and early twentieth centuries



**Debutantes at a ball.** Though variations exist, traditional dress for debutantes consists of a white formal gown, usually sleeveless, and long, white kid gloves. © SEATTLE POST-INTELLIGENCER COLLECTION; MUSEUM OF HISTORY & INDUSTRY/CORBIS. REPRODUCED BY PERMISSION.

to present a group of their daughters or granddaughters at a cotillion or ball. Social club cotillions are usually more formal than family balls with a master of ceremonies and a grand march or promenade before the dancing begins. All of the girls in the group must wear the same color, almost invariably white, but may choose their own style of dress. Long, white gloves are usually worn with strapless or sleeveless gowns (Post 1937, 1969, 1997). Individual parents may give an additional party sometime within the debutante social season, traditionally the period between Thanksgiving and New Year's when university students are home for the holidays (Mills 1959; Tuckerman and Dunnan 1995).

In the twentieth century, debutante balls, whether given by a family or by one of the exclusive social clubs, gained media attention, and the public began criticizing the lavishness of the events, particularly in the 1930s and 1940s. In the 1950s, subscription dances were organized to raise money for charity through debuts. For an entrance fee, debutantes could be introduced at an annual ball and the proceeds contributed to a charitable cause. One of the largest is the National Debutante Cotillion and Thanksgiving Ball, of Washington, D.C., benefiting the Children's Hospital National Medical Center. In addition to couching the social event within philanthropy, subscription debutante balls allow middle-class parents to

give their daughters a debut, as long as they have a sponsor from the cotillion organization. Financial requirements for balls usually include a participation fee, the purchase of a table for eight, and sometimes the purchase or sale of space in a souvenir book, and, of course, the mandatory dress and gloves. Subscription balls or cotillions vary in prestige and exclusivity, and the costs reflect these differences.

### Ethnic and Cultural Debuts

Every year thousands of fifteen-year-olds from a wide variety of Hispanic backgrounds celebrate their birthdays with a *quinceañera*, a unique combination of religion and debut that emphasizes cultural identity. Few young African American women make their debuts through the older social clubs, but many debut through African American organizations. The Van Courtlandt Society in San Antonio, Texas, was founded in 1915 and shortly thereafter began holding balls, and in Savannah, Georgia, the Alpha Phi Alpha fraternity has sponsored the Annual Debutante Presentation and Ball since 1944. Some African American debuts are as expensive and exclusive as those of the white balls, but others, like the Club Les Dames Cotillion of Waterloo, Iowa, are quite inexpensive and focus on the debutantes' social and academic accomplishments. The Chicago chapter of the Kosciuszko Foundation emphasizes scholastic achievement and community service in addition to the debts' Polish heritage. The San Marino Woman's Club of California requires that its debts perform a number of volunteer hours in community projects (Lynch 1999; Salcedo 1997). With the exception of the *quinceañera*, a fashionable white evening gown with long, white kid gloves is the standard dress for all of the above debuts.

### Regional Variation

Debutante events vary ethnically and socioeconomically, but the biggest difference in dress is regional. Mardi Gras debutantes in New Orleans wear jeweled gowns and long trains with Medici collars as well as glittering crowns, while Texas debts stray the furthest from classic white formals. For instance, in Laredo, Texas, young women from the oldest families wear elaborate eighteenth-century-style ball gowns with panniers, and middle-class debts wear heavily beaded ultra suede "Native American" costumes in pageants held during the annual George Washington Birthday celebration. During Fiesta in San Antonio, Texas, twenty-four duchesses, a princess, and a queen wear elaborately bejeweled gowns and trains in a faux coronation. The trains are based upon the requirements for English court presentations. The earliest ones were usually of satin and lightly beaded, but soon became the background upon which motifs from such themes as "The Court of Olympus" (1931) or "Court of the Imperial House of Hapsburg" (1987) could be represented in rhinestones and beads. They may weigh up to seventy-five pounds, and up to thirty-five thousand dollars is spent



### QUINCEAÑERAS: A HISPANIC RITE OF PASSAGE

*Quinceañeras* (from *quince* or fifteen) are traditional celebrations of a daughter's fifteenth birthday. Unlike Sweet Sixteen celebrations, they combine religious and social elements. A *quinceañera* begins with a full Catholic mass followed by a dinner and dance. Most parish priests require attendance at special religious classes before the event. The honoree wears a white or pastel dress with yards of ruffles and lace and is crowned with a tiara by her grandmother at the dance. Ten to fourteen of her closest friends and relatives, who with their escorts make up the court of honor, wear matching bridesmaid-like dresses. A boudoir-style "last doll" is dressed identically to the honoree and symbolizes the end of childhood (Salcedo 1997).

on the handwork. While wearing all of those rhinestones and beads, the young women must perform the royal bow in which they lower their bodies until they are essentially sitting on the floor and then bend forward from the waist until the head almost touches the floor. The bow has been copied all over Texas and is known as the "Texas dip" when it is performed by Texas debts at the International Debutante Ball in New York City (Haynes 1998).

### Conclusion

Although many people feared that debuts would disappear in the 1960s when such elitist and ostentatious displays of wealth came under heavy social criticism, debuts have actually become more prevalent. The benefits of debuts have even extended to young men at times. A small number of *quinceañeros* have been given for fifteen-year-old boys in Hispanic communities, and in Dayton, Ohio, the Beautillion Militaire has been held annually since 1968 for African American males. The organizers felt that since debutante events seemed to enhance self-esteem and raise the aspirations of the young women who participated in them, similar benefits might accrue to their young men taking part in similar events. Now, thousands of daughters (and a few sons) from a wide socioeconomic range become Cinderellas (or Prince Charmings) for a night.

See also **Evening Dress; Fancy Dress**

### BIBLIOGRAPHY

- Arch, Nigel, and Joanna Marschner. *Splendour at Court*. London: Unwin Hyman, 1987.
- Birmingham, Stephen. *America's Secret Aristocracy*. New York: Berkley, 1990.



Haynes, Michaele Thurgood. *Dressing Up Debutantes*. Oxford: Berg, 1998.

Lynch, Annette. *Dress, Gender and Cultural Change*. Oxford: Berg, 1999.

Mills, C. Wright. *The Power Elite*. New York: Oxford University Press, 1959.

Post, Emily. *Etiquette*. New York: Funk and Wagnalls, 1937.

———. *Emily Post's Etiquette*. New York: Funk and Wagnalls, 1969.

Post, Peggy. *Emily Post's Etiquette*. New York: HarperCollins, 1997.

Salcedo, Michele. *Quinceañera!* New York: Henry Holt, 1997.

Tuckerman, Nancy, and Nancy Dunnan. *The Amy Vanderbilt Complete Book of Etiquette*. New York: Doubleday, 1995.

*Michaele Haynes*

**DE LA RENTA, OSCAR** Born in Santo Domingo, in the Dominican Republic, on 22 July 1932, Oscar de la Renta traveled to Madrid when he was eighteen to study art at the Academia de San Fernando with the intention of becoming a painter. His career in fashion began when Cristóbal Balenciaga was shown some of his fashion illustrations, which led to a job sketching the collections at Eisa, Balenciaga's Madrid couture house. In 1961, eager to move to Paris, de la Renta went to work as an assistant to Antonio Castillo. Moving to New York in 1963, he was invited to design a couture collection for Elizabeth Arden. He later joined Jane Derby, Inc., as a partner in 1965 and founded his own company in 1967 to produce ready-to-wear.

Also in 1967, de la Renta married Françoise de Langlade, editor-in-chief of French *Vogue*. Together they became part of New York's fashionable social scene, often appearing in the society columns and giving valuable publicity to the label. His clothes initially showed the influence of his time at Balenciaga and Castillo: daywear of sculptural shapes in double-faced or textured wool that were cut to stand away from the body. It was also during his time at Lanvin that he developed his talent for creating feminine, romantic evening wear, which has remained his trademark.

In 1966 de la Renta became inspired by young avant-garde street fashions and produced minidresses with hot-pants and embroidered caftans. However, his love of the exotic and the dramatic soon surfaced, and by the 1970s he was one of the designers to tap into the desire for ethnic fashion, inspired by the hippie movement with its appropriation of other cultures. His embroidered peasant blouses, gathered skirts, fringed shawls, and boleros became part of mainstream fashion for the rich and the leisured. When in the 1970s the midiskirt was introduced, it was received with ambivalence and Oscar de la Renta was one of the designers to resolve the hemline quandary by incorporating trousers into his collections. The prevailing attitudes to women wearing trousers became much

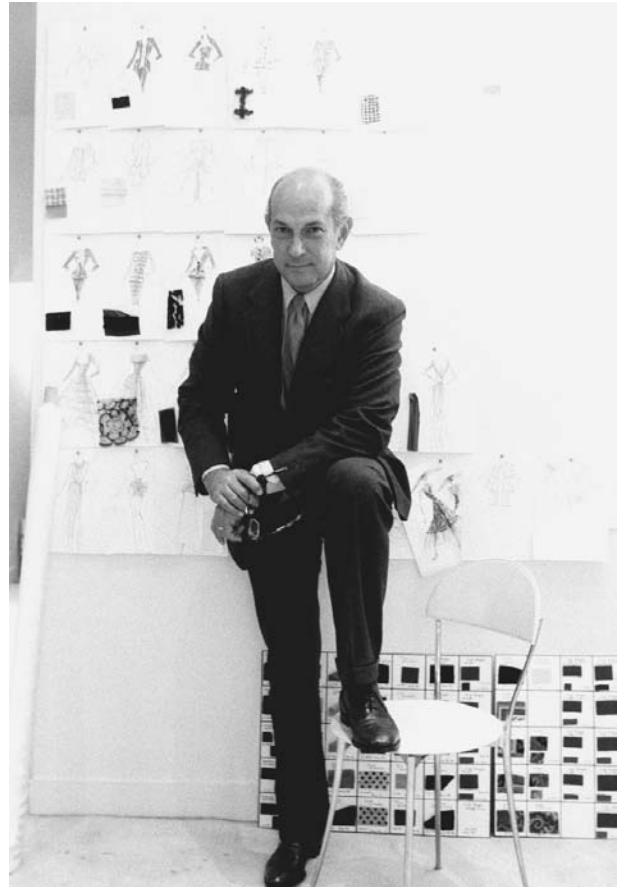

**Oscar de la Renta.** Though probably best known for his romantic eveningwear, de la Renta dabbled in many styles of clothing, such as ethnic fashions and elegant casual wear. © OWEN FRANKEN/CORBIS. REPRODUCED BY PERMISSION.

more relaxed as he and other designers sought to give panache to what was then only associated with casualwear and informal occasions. His evening wear in many ways continued the tradition of the American "sweetheart" dress, full-skirted, with a fitted bodice and belted waist and big sleeves, very often in a paper taffeta, brocade, or chiffon, and embellished with ruffles.

In January 1981 the inauguration of President Reagan reintroduced the notion of formal dressing and entertaining to Washington, D.C., replacing the southern homespun style of the previous incumbents of the White House, the Carters. Charity balls and black-tie dinners gave society every opportunity to dress up in lavish ball gowns, following the lead of the impeccably groomed Nancy Reagan. There was a new appetite for the luxurious and the ornate. Oscar de la Renta anticipated the change, remarking, "The Reagans are going to bring back the kind of style the White House should have" (Kelly, p. 259).

As one of the First Lady's favorite designers, and alongside Adolfo Domínguez, James Galanos, and Bill

Blass, he was favored with invitations to state dinners. It was a period when designers became part of the social scene, invited as guests to the grand occasions for which their clients required clothes.

De la Renta's talents lay in designing and producing spectacular ball gowns and evening dresses, reflecting the 1980s' predilection for ostentatious display and conspicuous consumption that epitomized the Reagan years. From 1980 to 1985 the American dollar had never been stronger, and it was during this period that de la Renta was able to consolidate his business, becoming a multimillionaire with eighty international licenses from household goods to eyewear. Television soap operas, such as *Dynasty* and *Dallas*, made universal the desire to dress up in luxurious fabrics and expensive accessories. During the 1980s de la Renta particularly favored the use of black with a single bright color, such as black and bright pink or black and emerald green, with a somewhat narrower silhouette and lavish use of embroidery, passementerie, and beading. Following the ingenué 1960s and hippie 1970s, fashion once more became about glamour for grown-ups. These classic dresses appealed to the more mature, leisured socialites, rather than the working women who were "power-dressing" in Donna Karan.

De la Renta introduced his signature perfume Oscar in 1977, for which he received the Fragrance Foundation Perennial Success Award in 1991. It was his scent Ruffles, however, in a distinctive fluted glass bottle, and produced in 1983, that reflected the ultrafeminine aspect of his clothes. As the advertisement read, "When a woman thinks of Oscar de la Renta she thinks of Ruffles."

Twice winner of the Coty American Fashion Critics' Award, in 1967 and 1973, de la Renta was inducted into the Coty Hall of Fame in 1973 and received the Lifetime Achievement Award from the Council of Fashion Designers of America in 1990.

In 2001 the designer was elected to the fashion walk of fame and honored with a commemorative plaque embedded into the sidewalk of New York's Seventh Avenue.

International acknowledgment came with his appointment as designer for the French couture house Pierre Balmain in 1993, the first American designer to be recognized in this way, and a reflection of the growing status of American designers worldwide.

The year 2001 saw the introduction of Oscar accessories—bags, belts, and jewelry, scarves and shoes—that reflect his passion for the ornate decoration of his native country. De la Renta has had a consistently high profile in fashion, from being the favorite designer of film star Dolores Del Rio in the early 1960s to receiving the Womenswear Designer of the Year Award from the Council of Fashion Designers of America in 2000, the honor that succeeded the Coty awards. His clothes reflect his passion for the romantic and the exotic resulting from a childhood and youth spent in the Dominican Republic and Spain. De la Renta's strength as a designer has al-

ways been his ability to combine his trademark love of the dramatic, with its roots in his Latin inheritance, with the American need for sophisticated elegance.

*See also* **Balenciaga, Cristóbal; Evening Dress; Fashion Designer; First Ladies' Gowns.**

#### BIBLIOGRAPHY

Coleridge, Nicholas. *The Fashion Conspiracy: A Remarkable Journey through the Empires of Fashion*. London: William Heinemann, 1988.

Kelly, Kitty. *Nancy Reagan: The Unauthorized Biography*. London: Transworld Publishers, 1991.

Milbank, Caroline Rennolds. *New York Fashion: The Evolution of American Style*. New York: Harry N. Abrams, 1989.

Marnie Fogg

**DELAUNAY, SONIA** The artist Sonia Delaunay sought ways to bring modern art out of the confines of traditional easel painting. She carried this out by refashioning everyday objects as tools to explore her theories of color and by infiltrating daily life with art in a way that traditional painting could not. While her involvement in the fashion business spanned less than a decade, her prolific career in textile designs and color studies continues to influence fashion designers.

Sonia Terk was born 14 November 1885 into a poor Jewish family in the Ukrainian village of Gradizhsk and adopted by her well-to-do aunt and uncle in Saint Petersburg at an early age. She studied art periodically in Karlsruhe, Germany, and continued her studies at the Académie de la Palette in Paris, where the intense color palette of artists of the fauvist movement influenced her early development as a painter.

In 1910 she married the painter Robert Delaunay, whose research into the theory of "simultaneity," or "Orphism," served as the basis for her lifelong experiments in color. This new style, which attempted an instantaneous visualization of the experience of modern life in all its complexity, conveyed rhythmic energy and dynamic movement through the creation of color contrasts on the painted surface. Sonia Delaunay's first "simultaneous" paintings include *Contrastes simultanés* (1912) and *Le Bal Bullier* (1913), and she created her first simultaneous dresses in 1913 to match the energy of the new foxtrot and tango at the popular Parisian dance hall Le Bal Bullier. She also collaborated with the poet Blaise Cendrars to design a simultaneous book, *La Prose du Transsibérien et de la Petite Jehanne de France* (1913). In the initial years of her marriage, she integrated the realms of home and art by fashioning her apartment in the simultaneous style, creating blankets, cushion covers, lampshades, goblets, and curtains.

The Russian Revolution of 1917 resulted in the cutting off of Delaunay's substantial family income, so she

turned to her marketable designs as a new means of financial support. Living briefly in Spain, she quickly established her public reputation as an innovator in both costume and fashion there by designing costumes for Sergey Diaghilev's *Cléopâtre* (staged in 1918) and showcasing simultaneous dresses, coats, home furnishings, and accessories in her store, Casa Sonia. This exposure earned her interior-decorating commissions from wealthy patrons and the Petit Casino theater (opened 1919).

In 1921 Delaunay returned to Paris and developed a new genre, *robes-poèmes* (poem-dresses), by juxtaposing geometric blocks of color and lines of poetry by Tristan Tzara, Philippe Soupault, and Jacques Delteil onto draped garments. She received a commission for fifty fabric designs by a Lyons silk textiles manufacturer, and over the next thirty years, the Dutch department store Metz and Company purchased nearly two hundred of Delaunay's designs for fashion and home decoration. In 1923 she designed costumes for Tristan Tzara's theater production *La coeur à gaz* (The gas-operated heart) and her first exhibition-style presentation of her textiles and clothing took place at the Grand Bal Travesti-Transmental.

The following year, Delaunay established her own printing workshop, Atelier Simultané, so that she would be able to supervise the design process of her prints. Embroideries in wool and silk combinations, sometimes accented with dull metal and mixed furs, incorporated a new stitch she invented, *point du jour*, or *point populaire*. Delaunay's meticulously embroidered and appliquéd coats brought commissions from the wives of fashion designers, artists, and architects, and from film and theater actresses including Gloria Swanson, who brought the Atelier much publicity.

Delaunay approached her textile designs in the same manner as her paintings. She incorporated rigorous yet simple geometric shapes, stripes, spirals, zigzags, and disks, crossing and intermingling with the strict discipline typical of constructivism. Colors were limited to four, occasionally five or six, contrasting hues in the same design: deep blues, cherry reds, black, white, yellow, or green, or softer combinations of browns, beiges, greens, and pale yellows. The vibrant synergy of these colors exemplified Delaunay's concept of modernity and the rhythms of an electrified modern city.

At the 1925 Exposition des Arts Décoratifs, Delaunay collaborated with the furrier Jacques Heim in displaying female fashion, accessories, and interior furnishing in her Boutique Simultané. That same year, the Librairie des Arts Décoratifs responded to the positive reception of her work by publishing an album of her fashion plates titled *Sonia Delaunay, ses peintures, ses objets, ses tissus simultanés, ses modes*. Delaunay's success with fashion lay partly in the adoption of the liberating, contemporary silhouette for female clothing that developed during World War I. The stylish, unadorned tunic cuts of the mid-1920s, with straight necklines, no waistlines, and few structural details, served as a blank, two-dimensional canvas for her

geometric forms. Shawls, scarves, and flowing wraps for evening gave her additional flat surfaces on which to explore, enabling her to expand her business. She also challenged traditional practices in the fashion industry. In a lecture at the Sorbonne, "The Influence of Painting on Fashion Design," she explained the *tissu patron* (fabric pattern), an inexpensive invention that allowed both the cutting outline for the dress and its corresponding textile design to be printed at the same time.

Financial pressures during the Great Depression, coupled with the 1930s trend toward fabric manipulation and construction details that did not accommodate her designs, led Delaunay to close her couture house in 1931. She foresaw that the future of fashion was in ready-to-wear, not the custom pieces she was creating. While she turned away from fashion design after this point, she continued to take private orders from the couturiers Chanel, Lanvin, and especially Jacques Heim.

Delaunay spent the rest of her life concentrating on painting and continued to apply her theories to a wide range of objects, including tapestries, bookbindings, playing cards, and a children's alphabet. She also became involved in projects with the poet Jacques Damase. Toward the end of her life, she exhibited frequently and was honored in 1967 with a major retrospective exhibition at the Musée National d'Art Moderne in Paris for her contribution to modern art. She died on 5 December 1979 at the age of ninety-four.

Textile and fashion design gave Delaunay the freedom of experimentation and spontaneity that she later transposed into her paintings. She brought art to the streets and made her wearable paintings an integral part of the everyday. Her artistry has had a profound influence on the work of contemporary fashion designers including Marc Bohan for Christian Dior, Perry Ellis, Yves Saint Laurent, and Jean Charles de Castelbajac, all of whom have referenced her work in their collections.

*See also Art and Fashion; Chanel, Gabrielle (Coco); Dior, Christian; Fashion Designer; Ellis, Perry; Lanvin, Jeanne; Saint Laurent, Yves.*

#### BIBLIOGRAPHY

- Baron, Stanley, with Jacques Damase. *Sonia Delaunay: The Life of an Artist*. New York: Harry N. Abrams, 1995. A comprehensive biography of the artist's personal and professional endeavors.
- Cohen, Arthur A. *Sonia Delaunay*. New York: Harry N. Abrams, 1975. Provides biographical and visual insight into the artist's overall career.
- Damase, Jacques. *Sonia Delaunay, Fashion and Fabrics*. Translated by Shaun Whiteside and Stanley Baron. London and New York: Thames and Hudson, 1991. An extensive collection of the artist's fashion illustrations and textile designs of the 1920s.
- Delaunay, Sonia. *Nous irons jusqu'au soleil*. Paris: Editions Robert Laffont, 1978. An autobiography based on journal entries starting from the early 1930s.



Morano, Elizabeth. *Sonia Delaunay: Art into Fashion*. New York: George Braziller, 1986. Explains the artist's impact on the development of modern fashion through a broad collection of fashion plates and textile designs.

*Angel Chang*

**DEMEULEMEESTER, ANN** Ann Demeulemeester (1959– ) was born in Courtrai, Belgium. When she presented her first winter collection in Paris in 1987, six years after graduating in fashion design from the Royal Academy of Fine Arts in Antwerp, the press release described her work as “a collection for the conscious woman.” The text went on to say, “[her] inspiration sources are neither directly definite nor visual; the clothes are brought about by personal impressions. A logical evolution, that is a result of a purification of ideas, which forms a specific style with its own atmosphere.” These words seemed appropriate in the early twenty-first century, as Demeulemeester's work could be read as an interpretation of a very personal universe—one that was not immediately traceable, but could be felt in every article of apparel she designed. At their core lay the study of form and the development of a personal signature, rather than introductions of new trends or fashions or working around seasonal themes. For Demeulemeester, designing was a form of problem-solving. In a rational, almost scientific manner, she sought a solution for each “problem,” often over several successive seasons. Cut and pattern were explored until the solution presented itself and perfection was achieved.

The experimental subject in this design laboratory was the designer's own body. Demeulemeester consistently tried out new creations on herself or on a select number of friends. The semiscientific aspect of Demeulemeester's creative process was in stark contrast with her ultimate silhouettes, which bore witness to intense emotion and extensive experience of life. However exhaustively thought out the cut may have been, the result was never sterile. The nonchalance that characterized her style was natural yet profoundly investigated; it was never just a matter of course. This dichotomy in Demeulemeester's creative process distinguished her entire oeuvre. Ann Demeulemeester sought out paradox; she seemed to go along with a certain duality or opposition in order to ultimately undermine it. Her investigation was in fact a study in search of balance, with the underlying thought that perfect balance is unattainable, just as the symmetrical body is in fact nonexistent—and for the designer, perhaps of no interest anyway. The shortcomings, the incompleteness, and the voids are what generate artistic creation. It was this continual search that lay at the root of Ann Demeulemeester's drive and passion—or as the text on a T-shirt and invitation suggested: *Aimer, c'est agir* (“to Love is to act”).

### **Motion and Gravity**

Motion was a leitmotif throughout Demeulemeester's work. The challenge of gravity, a force that allows ap-



**Model wearing Demeulemeester ensemble.** Demeulemeester liked to challenge gravity in her designs, creating garments that appeared to be in motion or were just barely held in check on the body. AFP/Getty Images. REPRODUCED BY PERMISSION.

parel to appear to be in motion even when its wearer is standing still, was technically explored in ever new applications, season after season. One symbol of this investigation was the feathers that reappeared in each new collection in the form of necklaces or jewelry, chosen for their beauty and natural perfection.

We are accustomed to the fact that gravity causes everything to fall, so how does one mislead a law of nature? How does one dislodge the balance of human form into balance, and how does one cut an article of clothing so that it looks as though it is being blown open? How does one summarize the beauty of a T-shirt that just happens to glide off the shoulder? Questions of this nature served as starting points for collections in which the different movements of Demeulemeester's models repeatedly accentuated and revealed different parts of the wearer's body—shoulders, stomach, or hips.

Unforgettable pieces in this context included Demeulemeester's asymmetrically-cut trousers that revealed part of the hips. Whether or not these garments were

held up with a subtle ribbon, they looked as though they were just on the verge of sliding to the floor. The movement was subtle yet introduced a hint of danger. Such techniques as drapery and asymmetrical cut as well as ribbons and belts provided the technical tools. When gravity could not be conquered, Demeulemeester made use of ribbons or belts—which had evolved into fetish elements in her collections—to hold the fabric against the wearer's body.

The designer felt a need to find different ways to develop an article of clothing without traditional pattern techniques. Demeulemeester's 1998 winter collection began with a piece of cloth into which she cut holes for her arms. Careful observation of what subsequently happened to the fabric led her to develop a number of wrapping techniques, which in turn produced new forms. In her winter collection for 1999, she pushed this approach even further by applying the wrapping techniques to sheepskin. The result was a most unexpected interpretation of the *mouton-retourné*.

The feeling of motion and nonchalance in Demeulemeester's work found its counterweight in her elegant jackets and pantsuits of the 1990s, which exuded a certain discipline and masculinity. Perfect in cut and shoulder line, here too, it was such details as an asymmetrical-buttoned blouse or the selection of a subtly hanging fabric, for example, that softened the severity of the whole. In her 1997 winter collection, both aspects came together in a jacket that closely hugged the body on one side with the help of a belt, but fell loosely on the other side.

### Materials

Alongside Demeulemeester's use of such supple fabrics as rayon, viscose, and silk, she had a passion for leather and fur, two hard-to-control materials that combine such opposites as aggression and tenderness. The tough character of the materials was undermined by the manner in which they were worked into the final pieces. One need think only of her elegantly draped wraparound jackets in fur (autumn–winter 2000–2001) or the jackets with large imposing capes that were produced in the finest leather for her 2002–2003 winter collection. The materials symbolized what the total silhouette demonstrated: the “wild warrior” versus the “fragile innocent girl.”

A third noteworthy material was white painter's linen or canvas, which Demeulemeester initially used for invitations, catwalks, the interior of her shop in Antwerp, and a table she designed in 1995—for which she was awarded the first prize in design from the Flemish Community. Demeulemeester first worked this white canvas into her apparel collection in 1999. Since Demeulemeester studied art before going into fashion design, she was especially fascinated by the nude female body and its proportions—a factor that continued to play a central role in her fashion design. Beginning from nothing, from empty space or nudity, in order to then add only the es-

entials without excess decoration, translated equally strongly into her emphatic choice of black and white, the two extremes of the color spectrum—a choice that is both hard and poetic. In the same way that a black-and-white photograph can embody the essence of an image, Demeulemeester was more interested in nuances, shadows, and forms than in decoration and color.

### Gender Issues

Demeulemeester showed her first collection for men in 1996, which was presented together with her collection for women. For Demeulemeester, men and women are not opposites, but rather form a balance around the same extremes. The flow and interchange of masculine and feminine characteristics could be found in the mannequins who modeled her clothes, in the punk singer Patti Smith (her frequently mentioned and quoted muse), but above all in the apparel itself. It is worth noting here that tough-looking shoes or boots more than once formed a symbolic counterpoint within one of Demeulemeester's silhouettes, such as her 1998 shoe, which mounted a man's shoe form on a high heel.

See also **Belgian Fashion; Gender, Dress, and Fashion; Margiela, Martin; T-Shirt.**

### BIBLIOGRAPHY

Derycke, Luc, and Sandra van de Veire, eds. *Belgian Fashion Design*. Ghent and Amsterdam: Ludion, 1999.

*Kaat Debo and Linda Loppa*

**DEMIMONDE** Nineteenth-century Paris was acknowledged by contemporaries as the “capital of pleasure” (Rearick, p. 40). Its reputation as a city of diversions and licentiousness was established following the Revolution and Reign of Terror during the period of the Directory (1795–1799), when a heterogeneous, parvenu society indulged itself in a hedonistic lifestyle. Returning émigrés, the newly distinguished, and the recently wealthy, as well as many visiting foreigners, enjoyed the city's luxury shops, restaurants, cafés, dance halls, public gardens, and boulevards. The pleasure-seeking atmosphere that characterized Paris in the Directory set the tone for the next hundred years.

The political upheaval of 1789 created a less rigidly stratified society than that of the *ancien régime*, a society in which birth and wealth no longer dictated access to power. Under Napoleon I and increasingly throughout the nineteenth century, a growing and affluent bourgeoisie claimed its right to the lifestyle and privileges formerly the prerogative of the elite. In this opportunistic culture of burgeoning capitalism and materialism, men and women were on the make. The social mobility, economic expansion, and, to a degree, the political uncertainty of nineteenth-century France gave birth to *le demimonde*.

Coined by Alexandre Dumas fils in 1852 for a title of his play *La dame aux camélias*, the inspiration for *La Traviata* and adapted as the film *Camille*, the term “demimonde” (literally, half-world) originally designated a class of fallen society women. But the definition came to be much broader, including all women of loose morals who lived at the edge of respectable society and, by extension, the men—royal, aristocratic, bourgeois, and bohemian—who frequented that ambiguous world. Although the demimonde certainly existed prior to the mid-nineteenth century, it was during the Second Empire (1852–1870) and the early Third Republic (1870–1914), that it flourished and that its supreme type, the courtesan, achieved spectacular notoriety.

### The Courtesan

In an age of limited career possibilities for women, the courtesan took maximum advantage of one of the oldest professions open to her. Prostitution was widespread in nineteenth-century Paris, but the courtesan was set apart from the anonymous streetwalker by virtue of the wealth and status of her protectors and her own celebrity and visibility on the social scene. In addition to their physical beauty and sexual attractiveness, the most successful courtesans were also personages. In Colette’s novella, *Gigi* (1944), Madame Alvarez, a former demimondaine and Gigi’s grandmother, sums up a (real-life) leading courtesan: “She is extraordinary. Otherwise she would not be so famous. Successes and celebrity are not a matter of luck” (Colette, p. 24). Accomplished in the arts of gallantry, courtesans were strong-willed and independent women as well as cultivated, entertaining, and witty.

The *cocottes* (literally, hens) and “grand horizontals” of the latter half of the nineteenth and early twentieth century were the culmination in an evolution of women of dubious character. The *grisette* (a reference to her gray work dress) of the First Empire (1804–1814) and Bourbon Restoration (1814–1830) was a tenderhearted, good-natured young woman, toiling in the fashion trades, who formed a relationship—based on love and necessity—with a student, artist, or writer. The more venal *lorette* made her appearance during the July monarchy of the bourgeois king, Louis-Philippe (1830–1848), a time of rapid growth and industrialization in France. In 1841, the French writer Nestor Roqueplan applied the name *lorette* to the kept women who inhabited the newly developed area in the ninth arrondissement, around the parish church, Notre-Dame-de-Lorette. Unlike the *grisette*, the *lorette* did not work for a living; instead, she sold her favors and relied on liaisons (sometimes simultaneous) with men of substantial (though not lavish) means to support her.

The ostentatious lifestyle and moral corruption of the Second Empire produced *la garde*, as the group of about a dozen of the most flamboyant *grandes cocottes* was designated. In fact, the *fête impériale*, or imperial party, has been described both by those who lived through it as well as later historians as the heyday of the demimondaine.



**Demimonde poster by Georges Redon, 1904.** Liane de Pougy, a star of the Belle Époque, strikes an uninhibited pose. De Pougy reigned at the top of the social structure of the “grand horizontals,” leading an ostentatious and flamboyant lifestyle. © SWIM INK/CORBIS. REPRODUCED BY PERMISSION.

Napoleon III himself set the example; among his several mistresses were some of the era’s most celebrated courtesans: Marguerite Bellanger, the Countess Castiglione, and Giulia Benini, known as la Barucci.

The Belle Époque, too, contributed its stars to the demimonde firmament. Liane de Pougy, Caroline Otero (“la Belle Otero”), and Emilienne d’Alençon, known as *Les grandes trois*, were the undisputed trio at the apex of the coterie of grand horizontals.

In his essay “The Painter of Modern Life” (1863), the French poet Charles Baudelaire refers to the courtesan (and her alternate type, the actress) as “a creature of show, an object of public pleasure” (p. 36). And indeed the larger-than-life personae of these women not only inspired novels, plays, and paintings (themselves often controversial), but also provided regular fodder for gossip columns in the popular press. Their fabulous gowns, extravagant jewels, lavishly decorated mansions, superb horses and carriages, notable lovers, and outrageous ex-



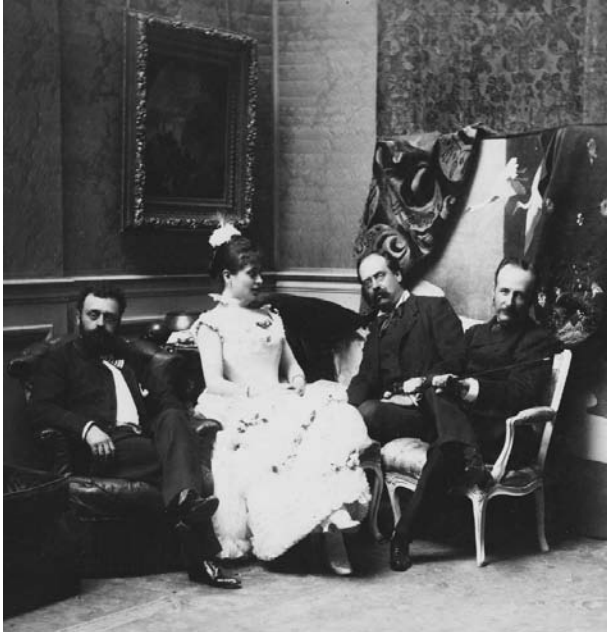

**Demimonde cocotte, ca. 1900.** Dressed in a long, ruffled evening gown and matching headpiece, a Frenchwoman entertains three men. *Cocottes* were women of dubious character in the late nineteenth and early twentieth centuries. © BETTMANN/CORBIS. REPRODUCED BY PERMISSION.

plots riveted the public's attention. The avariciousness of the courtesans earned them the unflattering neologism of *mangeuses* (eaters—of men and fortunes). Throughout the period, social commentators and writers such as Honoré de Balzac, Emile Zola, and Walter Benjamin linked the courtesan (and prostitution in general) with the rise of capitalism, speculation, commodity exchange, and a culture of consumption, and deplored their degenerative influence on society.

### The Courtesan and Fashion

As a signifier of modernity, fashion played an important part in nineteenth-century French society as a whole and for the courtesan in particular, for whom it was the primary vehicle by which she flaunted her power and challenged respectable women of the elite. The rules had changed since the eighteenth century when fashions were set by the court. Adopting a no-holds-barred attitude, the demimondaine used her enormous wealth and status as an outsider to wear the newest, most daring styles. Courtesans became the acknowledged leaders of fashion whose flashy ensembles were reported on, avidly studied, and often copied by upper- and middle-class women.

For the demimondaine, fashion operated on a number of levels. Many courtesans came from a background of poverty and obscurity. As the mistress of a wealthy man, having the means to dress in the height of fashion was surely a gratifying indulgence and a welcome source

of attention. But fashion was also a weapon in the battle between the *mondaine* (society lady) and the demimondaine. In the somewhat fluid society of nineteenth-century France, clothing was an all-important tool in the creation of persona. Fashion was unquestionably women's territory, and they were expected to take an active interest in its pursuit. Yet the society woman was confined by strictures of etiquette to maintain respectability in dress. The courtesan, on the other hand, was not bound by these same limitations. In fact, her conspicuous toilettes not only attested to her own originality in taste and sophisticated chic, they also reflected the wealth and generosity of her protector—in all likelihood, a married man. For the demimondaine, fashion was both socially and sexually empowering.

One of the most famous scenes in Emile Zola's novel *Nana* (published in 1880 but set in the Second Empire) illustrates this usurpation of sartorial prestige and supremacy by the courtesan. At the height of her success, Nana attends the Grand Prix de Paris at Longchamp dressed in a strikingly avant-garde and brazenly seductive ensemble. As a courtesan, Nana is prohibited from entering the weighing-in enclosure. However, on the arm of one of her aristocratic lovers, she gains admission to this exclusive preserve, where she walks slowly past the stands in full view of the empress and the wife of another noble lover whom she will eventually ruin. Zola's description of the dresses of the women in the enclosure is intentionally generalized; it is Nana's splendid costume that merits close observation in details of cut and color.

The blurred boundaries between the monde (high society) and the demimonde were nowhere more evident than in the patronage of leading couturiers by courtesans and society women alike. Charles Frederick Worth, considered the father of haute couture, created opulent toilettes for Empress Eugénie and women of the imperial circle. But his other, equally famous clients included Cora Pearl, who counted among her lovers the duc de Morny and Prince Napoleon (respectively half-brother and cousin to Emperor Napoleon III) la Païva, and other demimondaines of the era. At least on one occasion, a socialite and a demimondaine found themselves waiting for a fitting with Worth. Apparently, the couturier gave precedence to the courtesan. At the turn of the twentieth century, Maison Worth as well as more recently established designers such as Jacques Doucet and Jeanne Paquin continued to dress both women of the upper ranks and courtesans and actresses.

### The Urban Landscape

Paris of the Second Empire and Third Republic provided the appropriate setting for the demimonde and the courtesan. Under the direction of Baron Georges-Eugène Haussmann, Napoleon III's prefect of the Seine, Paris was transformed from a still largely medieval city with insular neighborhoods of dark, winding streets to a mod-

ern metropolis with a more uniform architectural style, straight, broad boulevards, and public parks. In this new urban landscape, arenas of fashionable life multiplied. Already fixtures of the Parisian scene, theaters, restaurants, cafés, and dance halls proliferated, while newer venues such as the *café-concerts* (music halls) became popular toward the end of the century. In Montmartre, the Moulin Rouge and the Folies Bergère drew large audiences from both the moneyed and the plebeian public.

Within Paris itself, the haunts—and breeding ground—of the demimonde were located on the Right Bank. Certain areas such as the Faubourg Saint-Honoré had been known for their luxury shops and *hôtels particuliers* since the eighteenth century. In the first half of the nineteenth century, other fashionable neighborhoods developed north of this older quarter, and by the second half of the century, the epicenter of “le high life” encompassed the Rue de la Paix, the Place Vendôme, the Rue Royale, the Boulevard des Italiens, and the Opera. The most renowned couturiers, jewelers, and silk and lingerie merchants all had their premises here. The well-known Théâtre des Variétés, which figures in the opening scene of *Nana*, and legendary restaurants such as the Café Anglais, the Maison Dorée, and Maxim, the scenes of dazzling parties and amorous intrigue, were also located in this area.

Fashion was an integral part of the demimondaine’s public lifestyle and one that required a different toilette for each occasion. Morning, afternoon, and evening dress varied depending on the season and the venue. Carriage dress, appropriate for the obligatory afternoon ride along the Champs-Élysées to the Bois de Boulogne, was deliberately showy. The scene in *Nana* referred to above depicts the fashion contest that took place at Longchamp amid the wide cross-section of society that attended the annual Grand Prix. At theaters catering to an upper-class audience, high fashion was on display both on the stage, as worn by leading actresses, and in the private boxes, where courtesans in décolleté gowns presided in the company of their admirers. Demimondaines of the Second Empire also made their mark at public dance halls such as the Jardin de Mabille, an open-air garden in the Avenue Montaigne patronized as well by Princess Metternich (a Worth client) and members of the exclusive Jockey Club. Since they were constantly on view, it was imperative for leading courtesans to make the most of fashion opportunities in their daily social schedule.

### The Demimonde Legacy

World War I brought to an end the rarified lifestyle of the Belle Époque and with it the phenomenon of the demimonde and courtesan. The social, economic, and cultural conditions that permitted the excesses of debauchery and squandering of fortunes were irreversibly changed. The demimondaines who lived beyond the war years were no longer the idolized, public figures they had

been. In their old age, many returned to a life of economic deprivation and obscurity.

Nonetheless, the demimonde has left its legacy in the wider world of twentieth-century fashion and celebrity culture. Actresses and performers such as Josephine Baker, Mae West, Marlene Dietrich, and Madonna have capitalized on their erotic appeal as a form of power and a significant aspect of their personae. Madonna in particular, in her collaboration with the French designer Jean Paul Gaultier, has explicitly challenged dress norms, exploiting the implications of both hyperfeminine and androgynous fashions. More than mere sex symbols, these women have an insolence and a flamboyance that derive from the example of the courtesan.

Popular culture of the past century has embraced different elements of the demimonde lifestyle, modes of behavior, and attitude toward fashion. Rock-and-roll musicians and their fans, for example, have carried on the tradition of social and sartorial rebellion and self-creation through clothing that defined the demimondaine. The discotheque and nightclub scene re-creates in a sense the ambiguous and socially mixed terrain of the demimonde with an undercurrent of dangerous glamour. The notoriously public lifestyle of celebrities in the early 2000s (film and sports stars, rock musicians, artists, socialites, and even royals), followed closely in the press, also mirrors that of the late nineteenth century. In these forms, the spirit of the demimonde continues to exert its influence.

See also **Balzac, Honoré de; Benjamin, Walter; Fashion and Identity.**

### BIBLIOGRAPHY

- Baudelaire, Charles. *The Painter of Modern Life and Other Essays*. Edited and translated by Jonathan Mayne. London: Pavidon Press Ltd., 1964.
- Clayson, Hollis. *Painted Love: Prostitution in French Art in the Impressionist Era*. New Haven, Conn.: Yale University Press, 1991.
- Colette. *Gigi; Julie de Carneilhan; Chance Acquaintances*. Translated by Roger Senhouse and Patrick Leigh Fermor. New York: Farrar, Straus and Giroux, 1980.
- Griffin, Susan. *The Book of the Courtesans: A Catalogue of Their Virtues*. New York: Broadway Books, 2001.
- Maneglier, Hervé. *Paris impérial: La vie quotidienne sous le Second Empire*. Paris: Armand Colin, 1990.
- Rearick, Charles. *The Pleasures of the Belle Époque: Entertainment and Festivity in Turn-of-the-Century France*. New Haven, Conn.: Yale University Press, 1985.
- Richardson, Joanna. *The Courtesans: The Demi-Monde in Nineteenth-Century France*. Cleveland, Ohio: World Publishing, 1967.
- Steele, Valerie. *Paris Fashion: A Cultural History*. Oxford: Oxford University Press, 1985.
- Zola, Emile. *Nana*. Translated by George Holden. New York: Penguin Books, 1972.

Michele Majer

**DEMOREST, MME.** Madame Demorest (1824–1898) created one of the most important and influential fashion empires in the late nineteenth century. She was born Ellen Louise Curtis in Schuylerville, New York, on 15 November 1824. After graduating from Schuylerville Academy at the age of eighteen, Ellen moved to Saratoga Springs, where she opened a millinery shop with the financial help of her father, a hat factory owner. She apparently achieved some success and decided to move to New York City with her business. There she met a widower, William Jennings Demorest, a dry goods merchant who had recently opened Madame Demorest's Emporium of Fashion on Broadway. Ellen Curtis and William Demorest married in 1858. A perfect embodiment of the new Madame Demorest's Emporium, Ellen was pivotal to the expansion and diversification of her husband's business and became one of the most influential arbiters of fashion of her era.

### Fashion Innovations

Madame Demorest's entrepreneurial success can be attributed to her astute understanding of the American fashion business as a combination of creativity, marketing, distribution, and brand identity. She claimed a number of innovative products, including a line of comfortable corsets, an affordable hoopskirt, the Imperial Dress-elevators (loop fasteners enabling skirts to be raised), and a sewing machine that could sew backwards; moreover, she developed the Excelsior Dress Model drafting system, a tool for making dress patterns. However, her mass-produced and marketed paper dress patterns remain her most important contribution. Madame Demorest's foray into paper patterns came at a time of great social change, when a growing middle class was clamoring for access to affordable fashions and technical advances like the sewing machine were becoming increasingly common in the home, making these fashion ambitions possible. Madame Demorest's paper patterns reached women across America and Europe, bringing them up-to-date fashions, a feat of no little importance.

### Evolution of Patternmaking

A Madame Demorest tissue-paper pattern for a boy's jacket was advertised in Frank Leslie's *Ladies Gazette* as early as March 1854. These early patterns were unsized and sold for twenty-five to fifty cents. Starting first with children's garments, Demorest moved to women's dress. The aim was to sell patterns for separate garments—bodices, sleeves, mantles, basques—that could be used in combination with others. Madame Demorest later made custom patterns by special order available. It was not until the early 1870s (nearly a decade after her archrival Ebenezer Butterick) that Madame Demorest was mass-producing sized patterns. The business burgeoned into an international enterprise within a few short years. In 1876 Madame Demorest sold over 3 million paper patterns throughout America and Europe.

### Demorest Publications

Marketing played an enormous role in the success of Madame Demorest's fashion empire. By employing the title "Madame," Demorest imbued her products with the cachet and allure of French fashions, reinforced in the early advertising in fashion journals such as Frank Leslie's *Ladies Gazette* and *Godey's Lady's Book*. Madame Demorest also promoted her products, especially the paper patterns, in the Demorests' own publications, which were generally managed by her husband. In 1860 *Madame Demorest's Mirror of Fashions* began quarterly circulation. The magazine featured plates of their own dress patterns and included a paper pattern stapled to the inside as an enticement to the reader. In 1864 the magazine was expanded to be *Demorest's Illustrated Monthly Magazine and Madame Demorest's Mirror of Fashions*. In 1865 the name was changed to *Demorest's Monthly Magazine and Demorest's Mirror of Fashions* (commonly referred to as *Demorest's Monthly*) and reached over 100,000 readers. At the peak of her career, Madame Demorest also produced *Madame Demorest's What to Wear and How to Make It* (1877–1884) and quarterly catalogs. She also expanded the *Demorest's Monthly* to London circulation.

### Merchandising

In addition to marketing through the magazines, the paper patterns were sold through a nationwide network of shops called "Madame Demorest's Magasins des Modes." In the mid-1870s there were 300 shops employing 1,500 (mainly women) sales agents. In addition to the paper patterns, the Excelsior drafting system was also showcased and sold at these satellite stores, which were located in major cities in the United States, Canada, Europe, and Cuba.

Madame Demorest continued to use the flagship Emporium store on Broadway to merchandise the full array of Demorest products. In the earliest years, Madame Demorest's Emporium of Fashion was located at 375 Broadway near Lord and Taylor and Brooks Brothers; then the business was moved to 473 Broadway in 1860. In 1874 the Emporium moved farther uptown, to 17 East Fourteenth Street, and catered to an increasingly fashionable set. The Emporium provided custom dressmaking services to wealthy clients, as well as ready-made accessories and undergarments; Demorest's unique line of cosmetics and perfumes; and, of course, the monthly magazines and paper patterns. Although it was only a small part of their overall business, the custom dressmaking service at the Emporium lent prestige and luxury to their name, a marketing tool that Madame Demorest was savvy enough to harness.

Madame Demorest's participation in numerous national and international exhibitions cemented her reputation as a fashion arbiter. A frequent exhibitor at London and Paris shows, she is noted as having created a large display at the Philadelphia Centennial Exhibition in 1876 in which she installed several women's and children's





### MRS. STRATTON'S WEDDING TROUSSEAU

One of Madame Demorest's most newsworthy custom dressmaking projects was the wedding trousseau she designed for Mrs. Charles Stratton, née Miss Lavinia Warren, in 1863. The Strattons were better known at the time as General and Mrs. Tom Thumb, midgets who toured with P. T. Barnum's circus. After their wedding in New York City, which was attended by 2,000 people, Mr. and Mrs. Stratton headed to Europe on a world tour that included reception at several royal households. The Madame Demorest reception dresses, worn by Mrs. Stratton at these functions, were widely publicized.

fashions; her drafting tool, "Dress Model"; and a huge case filled with paper patterns.

### Progressive Causes

In the 1880s Madame Demorest's fashion empire began to decline. Unlike her competitor Ebenezer Butterick, Madame Demorest had never filed patents for her paper patterns and eventually lost out in this arena. The paper pattern business was sold in 1887. In later years both Ellen and her husband, William, turned their attention to social causes that had always been of interest to them. William was deeply committed to the temperance cause, which often found expression in the pages of the *Demorest Monthly* magazine. Ellen increasingly supported women's causes. Both Demorests were strong advocates of abolition and deserve particular recognition for their unusually progressive business policy of hiring African American women agents who were treated equally with their white employees, sharing workplaces and receiving equal pay.

At the height of her career in the 1870s, Madame Demorest could rightly claim to be one of the most influential fashion disseminators of her era. Her paper patterns and fashion magazines reached millions of women in America and Europe, bringing sophisticated yet affordable fashions to the masses. At the same time, Madame Demorest created brand identity through her innovatively named lines of accessories and cosmetic products, while burnishing her reputation for quality through her luxury dressmaking establishment. While it could be said that she appeared at the right place at the right time when a population of women had the inclination and means, via the sewing machine, to make fashions at home, Madame Demorest was singularly astute in her comprehension of women's fashion needs and her ability to market to them through the widely read Demorest publications.

See also *Godey's Lady's Book; Patterns and Patternmaking; Sewing Machine.*

### BIBLIOGRAPHY

- Drachman, Virginia G. *Enterprising Women: 250 Years of American Business*. Chapel Hill: University of North Carolina Press, 2002.
- Emery, Joy. "Development of the American Commercial Pattern Industry: The First Generation, 1850–1880." *Costume* 31 (1997): 78–91.
- Gamber, Wendy. *The Female Economy: The Millinery and Dressmaking Trades, 1860–1930*. Urbana: University of Illinois Press, 1997.
- Kidwell, Claudia Brush. *Cutting a Fashionable Fit: Dressmakers' Drafting Systems in the United States*. Washington, D.C.: Smithsonian Institution Press, 1979.
- Milbank, Caroline Rennolds. *New York Fashion: The Evolution of American Style*. New York: Harry N. Abrams, 1989.
- Mott, Frank Luther. *A History of American Magazines*. Cambridge, Mass.: Belknap Press of Harvard University Press, 1938.
- Ross, Ishbel. *Crusades and Crinolines: The Life and Times of Ellen Curtis Demorest and William Jennings Demorest*. New York: Harper and Row, 1963.

Lauren Whitley

**DENIM** Twill patterns of weaving seem to have developed early in the first millennium B.C.E. Hallstatt culture in Europe. Technically speaking, denim is a warp-faced twill weave fabric. The most basic twill weave calls for passing the weft (crosswise) yarn over two and under two warp (lengthwise) yarns (2/2 twill), a pairing that gives the pattern its name, two-ing or twill. In warp-faced twills, warp yarns are predominant on the front or face of the fabric and because warp yarns have a higher twist, the resulting fabric is stronger than many other weaves. In denim, the warp-faced twill pattern calls for passing the weft yarn over one and under two (1/2), or over one and under three warp (1/3) yarns. Because there are fewer lacings in twills than in plain weaves, the yarns are freer to move when being worn resulting in a fabric that is both flexible and resilient. The fewer the lacings, as in twills compared to plain weaves, the closer together yarns may be packed, thus producing a higher number of yarns per inch, making the resulting fabric stronger yet.

Popularly speaking, denim has been associated with fabric coloring, garment style, and lifestyle. Whole books have been written about twentieth-century denim and its popularity with teenagers and celebrities. The word has become so popular and generic in its use that rock bands, stage troupes, and even bottled water, have taken the name denim. The name itself is derived from Nîmes, a small city in southern France that had long been famous for its textile industry.

Levi Strauss is given the credit for the common use of denim in the rugged trousers first sold to gold miners



### GOODBYE TO AN AMERICAN ICON

On 26 September 2003, the *San Francisco Chronicle* announced that in 2004 plant closings would mark the end of the Levi's U.S. jeans-making era. Levi Strauss & Co. was a reflection of more than 150 years of American history, from the rough days of the California Gold Rush and the opening of the wild west, through the Great Depression. The impact of Levis grew during two world wars and Vietnam resulting in fashions that emphasized casual dress and conspicuous consumption simultaneously. Through it all, Levi Strauss & Co. became an icon with undisputed class.

during the California gold rush of the 1850s and 1860s. While the twill weave used in those first trousers for gold miners was undeniably harder than the plain weave that canvas miners had been wearing, it was the metal-riveted pockets that began to appear in the 1860s and 1870s that most interested the miners.

Jacob Davis, a tailor and wholesale customer of Levi Strauss, came up with the idea of putting metal rivets at the points of stress on denim trousers. Strauss hired Jacob Davis to oversee the manufacturing in San Francisco of the blue denim "waist overalls" as they were called. On 20 May 1873, Davis and Strauss received patent #139,121 from the U.S. Patent and Trademark Office for an "Improvement in Fastening Pocket-Openings." The riveted waist overalls were made from denim fabric furnished by the Amoskeag Mill in Manchester, New Hampshire. The waist overalls that are commonly called "jeans" or "blue jeans" were a hit with miners and other workers whose clothing had to be rugged. Cowboys who often spent days, and even nights, in the saddle herding cattle wore the trousers extensively.

In the 1900s, denim was most associated with rugged trousers dyed indigo blue. It is not known exactly when or why jeans or waist overalls yarns first began to be dyed blue. One of the best reasons given is that blue seems to hide dirt and stains better than the tan first associated with waist overalls. The uneven surface of twill weaves hides soil as well. Also, because the yarns can be more tightly packed in twills than in plain weaves, the fabric resists soiling by liquid spills.

Until the 1920s and 1930s denim waist overalls were scarcely known east of the Mississippi River. They were worn in the West as work pants.

From the mid-to-late 1950s and 1960s, blue denim ceased to be used mostly for work clothes. Indigo or blue

denim became a hot fashion item. Men's and women's suits were made from denim, as well as evening dresses, which began to be studded with rhinestones instead of rivets. In the 1960s denim blue jeans became one of the signs of rebellion among teenagers and twenty-something young adults. The young rebels, known as hippies and flower children, embroidered their jeans and painted them with flowers, peace signs (in protest of the U.S. involvement in Vietnam), and psychedelic designs.

In the 1980s and 1990s, denim became associated with various shades of blue as much as with its twill weave. Sheets, pillowcases, upholstery, bathing suits, dresses, leather and cloth shoes, underwear, paper, and even pencils were called "denim." Wood furniture was stained to have a denim appearance.

Almost every well-known European and U.S. designer from Calvin Klein to Giorgio Armani has made denim part of their fashion lines. Denim was seen as an American lifestyle fabrication and style. Denim was no longer the fabric of choice for just the blue-collar worker. It became an upper-class classic, even "preppy" look. Casual denim skirts and trousers were often combined with cashmere jackets and mink or ermine coats on the runway and on the streets. Denim trousers became accepted in high profile, black-tie events, worn with a formal tuxedo shirt and jacket. Virtually the only place where the casual nature of blue jeans remained unacceptable was in the dress of attorneys in the courtroom.

Old or vintage blue denim was very popular in the 1980s and 1990s, particularly in Asia and the United States. In Japan, the demand for vintage denim blue jeans was so great in the 1990s that it outstripped supplies.

Blue denim jeans in the 1990s were decorated extensively with colorful braid and glass bead fringe at the waist and edges of trouser legs. Legs of denim jeans were often slashed from the mid-thigh to the trouser leg edge and then laced with cord. Cotton was combined with latex for a fabrication that could be worn skintight and yet remain comfortably elastic. Denim was produced in colors other than blue, including black, green, pink, and tan—but those colors never attained the popularity of blue denim. In the early 2000s, it appears that denim will never be seen as a fad. It is an international classic.

*See also* **Jeans; Levi Strauss & Co.**

#### BIBLIOGRAPHY

- Barber, E. J. W. *Prehistoric Textiles: The Development of Cloth in the Neolithic and Bronze Ages with Special Reference to the Aegean*. Princeton, N.J.: Princeton University Press, 1991.
- Kadolph, Sara J., and Langford, Anna L. *Textiles*. 8th ed. Upper Saddle River, N.J.: Prentice-Hall, 1998.

#### Internet Resource

- Levi Strauss & Co. 2001. Available from <<http://www.levistrauss.com>>.

*Carol Anne Dickson*

**DEPARTMENT STORE** The birthplace of the department store was Paris. The Bon Marché opened in 1852, soon followed by Printemps (1865) and the Samaritaine (1869). Existing shops in the United States—Stewart in New York, Wanamaker in Philadelphia and Marshall Field in Chicago—adopted the format during the 1870s. The department store brought together a series of retail methods tested out in smaller European and American shops earlier in the century, for example, the proto-department stores in industrial cities in the north of Britain (Lancaster, chapter 1). The department store proper was distinctive from previous experiments in its scale, lavishness, and resonance with the society that spawned it. The early Parisian stores were hugely influential models for subsequent stores springing up all over the world. The history of the department store has been largely located in Western Europe and North America. The arrival of the format in East Asian cities such as Shanghai and Tokyo in the early twentieth century has been associated with westernization, but the stores were often locally owned and managed, creating complex issues surrounding their identity.

The conditions for the rise of the department store lay in late-eighteenth- and early-nineteenth-century industrialization and urbanization, which led to the growth of prosperous, urban, middle-class populations and the ready availability of mass-produced consumer goods, along with an increasingly sophisticated understanding of the pleasurable rather than merely utilitarian possibilities of consuming them. Important department stores were situated in urban centers, on principal shopping streets, working in conjunction with other shops, entertainment venues, and transport networks. However, well-heeled suburbs also had department stores in their high streets. By the late nineteenth century, considered the hey-day of the department store, these shops had become emblematic of metropolitan modernity and were famously made the backdrop of Émile Zola's novel *The Ladies' Paradise*.

The major department stores of each important city—for example, Harrods, Liberty's and Selfridges in London—quickly became urban landmarks and cultural institutions, cited in guide books as tourist attractions. During the early twentieth century, American stores took the lead as innovators, becoming increasingly influential on their European counterparts. During the interwar and early postwar periods, while alternative shopping sites were developing, fashion magazines such as *Vogue* show that the big department stores retained their central position within urban consumption practices in many cities. However, despite stores' attempts to address broader sections of the population, the opening of teen departments and the provision of new buildings, fundamental modernization of the format did not occur. The combined competition from the multiple store and alternative boutique in the urban high street and from the suburban shopping center and out-of-town mall led to a slow decline in the cultural and economic importance of the department

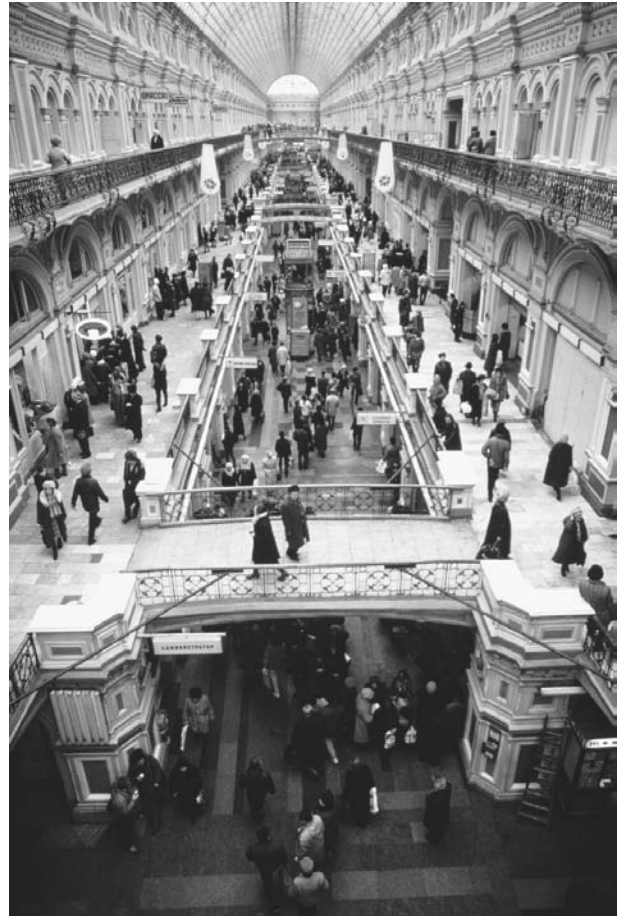

**Moscow's GUM department store.** Formerly known as the State Department Store, Gosudarstvenny Universalny Magazin (GUM) is located in Moscow's Red Square. Its three stories of shops boast some five kilometers of shelves. © DAVID H. WELLS/CORBIS. REPRODUCED BY PERMISSION.

store from the 1960s, accelerating during the 1980s. There were several factors that increased a store's chances of survival: possession of an international reputation, such as that of Harrods, London; absorption into a larger group, such as the House of Fraser or the John Lewis Partnership; positioning on a major metropolitan shopping thoroughfare or as the anchor in a shopping center. The early twenty-first century has witnessed a revival of the metropolitan department store, connected with a renewed focus on luxury goods and designer fashion, prime examples being Selfridges and Liberty in London. The department store has proved to be enduring.

#### **Stock Diversity and New Selling Methods**

An important innovation of department stores was their wide variety of merchandise, breaching the boundaries of previously largely trade-specific shop-keeping. Many of the early department stores actually developed from smaller existing shops, most commonly drapers. They



grew department by department, taking over neighboring properties to house the expanding businesses, until it was necessary to provide a new building or reface the existing ones to provide coherence. Department store pioneer William Whiteley famously boasted that he sold “everything from a pin to an elephant.” The system worked on a basis of low margins and high turnover. The stores were certainly a place for the sale of mass-produced goods and have been associated with the rise of ready-to-wear clothing. However, most stores continued to provide traditional tailoring and drapery well into the twentieth century. The diversity of stock was matched by an array of amenities and entertainments, including banks, restaurants, travel agents, fashion shows and live music, and services such as free delivery and alteration of garments.

Store histories are entwined with those of their owning dynasties, who usually gave their name to their stores, for example, the Wertheims and Schockens in Germany and the Lewises in England. Stores often merged with or were taken over by other stores, for example, the evolving nature of Britain’s House of Fraser described by Moss and Turton. The business was organized in a hierarchical, rational, and paternalistic manner. Strict control of the workforce was balanced with benefits such as health-care, pensions, and social clubs. Indeed during the early days many of the employees lived in the upper stories of the building. This practice faded out following several high profile, devastating fires caused by gas lighting and poor fire-proofing of buildings. The stores required vast staffs; for example, Harrods of London had 4,000 employees in 1914. For nineteenth- and early twentieth-century social commentators and novelists, the figure of the young female shop assistant symbolized the dubious respectability, moral ambiguity, and blurring of class boundaries they found so disturbing about the department store. However, until the interwar period, the majority of employees were actually male and lower middle class. Positions were sought after, although salaries were low.

### Customers and a New Kind of Shopping

From the beginning, the department store was associated with bourgeois consumers. As Miller has argued, “The department store was . . . a bourgeois celebration, an expression of what its culture stood for and where it had come over the past century” (Miller, p. 3). It was also initially seen as the exclusive province of women. The stores’ provision of basic amenities such as lavatories and refreshment rooms made a day trip to town newly accessible for suburban and provincial middle-class women, enabling them to take advantage of improved public transport networks. Early department store owners, such as William Whiteley of Bayswater in London, were vocal in their claims to make shopping in the city a safe and respectable activity for unchaperoned women (Rappaport). However, they also attempted to exploit feminine desires using new ideas about consumer psychology.

The distinctiveness of the department store model lay as much in the presentation of shopping as a pleasurable leisure activity as with the nature or number of goods available. Previously, shopping models had largely favored counter service and the acknowledgment of an obligation to buy once the shop was entered. In the new stores, the role of the retail staff was redefined and a different kind of shopping was encouraged, characterized by window shopping and browsing through displays of goods with fixed and ticketed prices. These practices drew on the cultures of the international exhibitions that followed London’s Great Exhibition of 1851. All this, it was believed, would encourage impulse buying.

During the early twentieth century, department stores began to cater to men with dedicated departments. In 1936 Simpson Piccadilly opened in London’s West End, claiming to be the first department store entirely for men. The lower ground floor alone was designed to house a barber’s shop, soda fountain, gun shop, shoe shop, chemists, florist, fishing shop, wine and spirit shop, luggage shop, snack bar, dog shop, sports shop, cigar and tobacconists, gift shop, saddlery shop, theater agent, and travel agent. During the opening months the aviation department even exhibited full-sized airplanes. The opening of the store coincided with new ideas about masculinity, which allowed for the adoption of shopping methods previously labeled feminine. *The Lady* (7 May 1936) commented on this, “It is amusing to find that the man’s shop is designed and set out with all the allure of one devoted to women’s luxuries. Shopkeepers, evidently, do not share that masculine theory that a man always knows just what he wants and so is immune from display or advertisement.”

### Design, Display, and Advertising

Zola called the department stores “cathedrals of commerce” and they were certainly associated with lavish, striking, and fashionable architecture, acting as an advertisement for the goods inside. Famous and innovative architects were often employed: Victor Horta designed Innovation in Brussels (1901), Louis Sullivan designed Carson Pirie Scott in Chicago (1899–1904), and Erich Mendelsohn designed the Schocken store in Stuttgart (1926–1928). The *Scotsman* commented on the opening of Simpson Piccadilly in London designed by the modernist architect Joseph Emberton, “the building is an expression in every way of the modern spirit” (4 May 1936). But the buildings were not just fashionable shells. The latest technological advances were used to assist the retail process. Iron then steel frames created vast uninterrupted expanses of floor space and plate glass technology facilitated story-high bands of display windows flanking the shopping street. Inside, escalators and lifts were installed, helping to sustain a continuous flow of customers between the street and the upper echelons of the building. Pneumatic tube systems were provided for commu-

nication and placing orders. Tiers of galleries allowed light from the roof to penetrate the shop floor, assisted by the pioneering use of first gas then electric lighting. Lighting was also used on the facade of the building—floodlighting, lit signage, and window illumination—so that the stores had a nighttime presence in the city, catching the eye of revellers.

Department stores led the way with developments in retail display, with opulent displays of goods inside the stores, in the shop windows, and sometimes spilling onto the streets. Displays were often themed in relation with events being held in the stores or national celebrations. It was the shop window in particular that became emblematic of the department store's contribution to the urban spectacle and seduction of customers. The early department stores had a particularly sophisticated understanding of the power of advertising. To the consternation of traditional smaller-scale retailers, significant amounts were spent on newspaper and magazine advertisements, and on regular publishing of catalogs, the Bon Marché in Paris distributed 1.5 million catalogs. In 1894 (Crossick and Jaumain p. 12). This emphasis on design, display, and advertising was integral to the new kind of shopping promoted in the department store, encouraging consumption through the exploitation of visual pleasures.

See also **Boutique; Liberty & Co.; Retailing; Shopping; Window Displays.**

#### BIBLIOGRAPHY

- Crossick, Geoffrey, and Serge Jaumain, eds. *Cathedrals of Consumption: The European Department Store*. Aldershot, U.K.: Ashgate, 1999. The key text in the field: an excellent and diverse edited collection of essays.
- Lancaster, Bill. *The Department Store: A Social History*. London and New York: Leicester University Press, 1995. A comprehensive study of the British department store in social historical terms.
- Leach, William. *Land of Desire: Merchants, Power and the Rise of a New American Culture*. New York: Vintage, 1993. A lively account of the American story from the 1890s to the 1930s.
- MacPherson, Kerrie L., ed. *Asian Department Stores*. Richmond, Surrey U.K.: Curzon, 1998.
- Miller, Michael. *The Bon Marché: Bourgeois Culture and the Department Store, 1869–1920*. Princeton, N.J.: Princeton University Press, 1981. A case study of the first department store, highlighting issues of class and business methods.
- Moss, Michael, and Alison Turton. *A Legend of Retailing: House of Fraser*. London: Weidenfeld and Nicolson, 1989. A detailed, well-illustrated account of one of Britain's most important department store groups.
- Rappaport, Erika Diane. *Shopping for Pleasure: Women and the Making of London's West End*. Princeton, N.J.: Princeton University Press, 2000. A contextual study of the department store in its West End location in the Victorian and Edwardian eras, focusing on issues of gender.
- Zola, Émile. *The Ladies' Paradise*. Oxford U.K.: Oxford University Press, 1998. This is a translation of Zola's novel *Au*

*bonheur des dames*, first published in 1883, reputedly based on the Bon Marché.

Bronwen Edwards

**DIANA, PRINCESS OF WALES** In 1997 the influential fashion photographer Mario Testino shot a series of seminal images of Princess Diana wearing Gianni Versace for *Vanity Fair* magazine. These photographs have come to define the look and glamour of a woman who became an important fashion icon of the twentieth century. In the early twenty-first century, media interest in her image remained undiminished.

Diana Frances Spencer (1961–1997) was born in Park House on the Queen's estate at Sandringham, the third child of Johnny, eldest son of the seventh earl of Spencer and a member of one of England's most important aristocratic families. In 1969 when Diana's parents were divorced, her father retained custody of the children, and in 1975 when Diana was fourteen, the seventh earl died, and the family moved to their ancestral home, Althorp in Northampton. When she was seventeen, her father bought her an apartment in Kensington, London, where Diana found work as a nanny until the day of her engagement to Prince Charles was announced.

The couple married on 29 July 1981, at St. Paul's Cathedral. Diana's wedding dress, designed by Elizabeth and David Emanuel, was a fairy-tale fantasy showcasing traditional English craftwork. It featured woven silk taffeta by Stephen Walters of Suffolk and historic lace from a flounce of Carrickmacross lace owned by Queen Mary and from the Nottingham Company, Roger Watson. The dress became one of the most famous outfits in the world, and the twenty-five-foot train added a touch of theatricality that would create an enduring image of the event, which was watched on live television by more than one billion people worldwide.

From that moment the princess became an international figure, photographed and documented wherever she went, and she became a global fashion icon. Diana loved clothes; they were a personal passion but also a requirement of her new public life. As one of the most important members of the British royal family, her wardrobe requirements were fixed in a world that required ball gowns and matching hats, shoes, and handbags, items that were not typical of mainstream fashion for young women in the early 1980s.

It is not surprising then that in the early years of her marriage she was steered toward established British fashion designers, including Murray Arbeid, Belville Sassoon, and Gini Fratini, whose traditions of classic tailoring for day and romantic evening wear dated back fifty years. Diana was, however, determined to stamp a modern and youthful personal style on this public and formal persona, and, more than any other British designer, Catherine



**Dress worn by Princess Diana.** Diana worked within the boundaries of royal tradition to create her own modern style, which was both elegant and youthful, quickly elevating her to fashion icon status. AP/WIDE WORLD PHOTOS. REPRODUCED BY PERMISSION.

Walker helped her to develop an elegant, tailored look that became her own.

From the 1980s Catherine Walker helped Diana create a streamlined modern version of clothes for her public life as the Princess of Wales. After her divorce from Prince Charles, Diana went on to develop a more individual style that reflected her new independence and freedom. Diana understood her role as a fashion icon and that everything she wore—every new accessory and change of hairstyle—would be scrutinized. In the 1990s, in search of a new look, she remained loyal to British designers, notably Jacques Azagury, who encouraged her to wear dresses cut revealingly low and to wear shorter skirts. Increasingly, however, she turned to European designers—the Italian designers Versace and Valentino and to the French couture houses of Dior, Lacroix, and Chanel. Her look became more international with a sophisticated and simple silhouette and an effect that was all in the details. Superb cut and luxurious materials worn with coordinated colored accessories, handbags, jewelry, and shoes became her hallmark. It is this image that defined an enduring fashion look of the late twentieth century.

*See also* **Royal and Aristocratic Dress.**

#### BIBLIOGRAPHY

- Howell, Georgina. *Diana: Her Life in Fashion*. New York: Rizzoli International, 1998.
- Tierney, Tom. *Diana, Princess of Wales, Paper Doll: The Charity Auction Dresses*. New York: Dover Publications, Inc., 1997.

*Catherine McDermott*

**DIOR, CHRISTIAN** The French couturier Christian Dior (1905–1957) was born in Granville, France. Descendant of a manufacturing family of the Norman bourgeoisie, Dior spent his early childhood in the comfortable surroundings of the family villa, Les Rhumbs, located on the Channel coast in Granville, which now houses a museum dedicated to his memory. At that time the little port was celebrated as a fashionable seaside resort, and in summertime it was transformed into “an elegant Paris neighborhood.” The family moved to Paris in 1911, to the new bourgeois neighborhood of Passy, near the bois de Boulogne.



Following his father's wishes, Dior registered at the *École de Sciences Politiques* in Paris after passing his baccalaureate. He eagerly followed Parisian artistic developments and met various writers, painters, and musicians, befriending, among others, Pierre Gaxotte, Maurice Sachs, Jean Ozenne and his cousin Christian Bérard, Max Jacob, and Henri Sauguet. In 1927, after his military service and with his father's support, he opened an art gallery at 34, rue de la Boétie. Because his parents refused to have their name on a commercial sign, the establishment was given the name of his associate, Jacques Bonjean. The gallery exhibited the works of such contemporary artists as Giorgio de Chirico, Maurice Utrillo, Salvador Dalí, Raoul Dufy, Marie Laurencin, Fernand Léger, Jean Lurçat, Pablo Picasso, Ossip Zadkine, Georges Braque, and Aristide Maillol.

Christian Dior's carefree youth soon came to an end: in 1931 his brother was institutionalized, his mother died, and his father was completely ruined financially. "In the face of this accumulation of tragedies," Dior reacted by a "flight to the East." He was "naïvely impelled by a desperate search for a new solution to problems that this crisis of capitalism had made acute," embarking on a study trip to the Soviet Union with a group of architects, only to find on his return that his associate was also ruined. His impoverished family abandoned Paris, retreating first to Normandy and later taking refuge in the village of Callian, near Cannes. Dior stayed behind in Paris, closing his first gallery and later joining the gallery of Pierre Colle on the rue Cambacérès. He thus went from "losses to forced sales while continuing to organize surrealist or abstract exhibitions that drove away the last art lovers." In 1934 he had an attack of tuberculosis, and his friends took up a collection to send him for treatment. The following year he found himself in Paris with no income and no place to live. He survived on the sale of one of his last canvases, *Le plan de Paris* of Raoul Dufy, which the designer Paul Poiret had sold to Dior when he was in similar destitute circumstances.

### Couture and Costume

Jean Ozenne, who was designing for couture houses, introduced Dior to the fashion world and to his clientele. At the age of thirty, Dior devoted himself to studying fashion drawing, referring only to what he knew and appreciated of Edward Molyneux, Coco Chanel, Elsa Schiaparelli, and Jeanne Lanvin. He managed to sell his first sketches of hats and then of dresses. His clients were fashionable hat makers and couture houses but he "also sold ideas to foreign buyers." Publication of his drawings in *Le figaro* produced his first public recognition. In 1937 the couturier Robert Piguet selected four of his designs and asked him to produce them for his "half-collection" (midseason collection). Christian Dior was just thirty-two, and these were, he said, the "first dresses that I really created."

In June 1938 Robert Piguet offered him a position as a designer in his couture studio located at the Rond Point of the Champs Élysées. There he designed three collec-



**Christian Dior.** Christian Dior opened his first salon in Paris in 1946 and had expanded his network of shops to twenty-four countries before his death by a heart attack in 1957. THE LIBRARY OF CONGRESS. PUBLIC DOMAIN.

tions in a row. The second contained his "first wide dresses," inspired by dresses worn by young heroines of the French second empire children's literature "les petites filles modèles" (well-behaved little girls). They were characterized by a "raised bust, round width starting from the waist, petticoat of English embroidery." As the creator of a successful design called "English coffee," he was introduced to Carmel Snow, editor of *Harper's Bazaar*. In 1939 his last prewar collection for Piguet launched the line of what came to be called "amphora dresses" marking the "beginning of rounded hips." In parallel with his work as a designer, Dior designed theater costumes for individual clients. He dressed, for example, the actress Odette Joyeux in *Captain Smith* by Jean Blanchon (at the théâtre des Mathurins, December 1939) and in *The School for Scandal* by Richard Sheridan (at the same theater, February 1940).

Dior was mobilized at the outbreak of war in 1939 and then joined his family in the unoccupied zone of France

after the 1940 armistice. Piguët, still in Paris, asked him to resume his prewar position, but Dior was late in replying and found the position already taken by Antonio del Castillo in the fall of 1941. Dior then went to work for Lucien Lelong, together with another young designer, Pierre Balmain. The two shared design responsibilities throughout the war: "Balmain and I never forgot that Lelong taught us our profession in the midst of the worst restrictions," said Dior. The personality of Lucien Lelong, the clever president of the *Chambre syndicate de la couture parisienne* (association of haute couture) throughout the German occupation of France, deeply influenced the future couturier. After his study trip to the United States in 1935 and the launch of his *Édition* line, Dior had developed an interest in foreign markets and high-end ready-to-wear. In contrast, he saw fashion under the German occupation as "appalling" and exclaimed: "With what vengeful joy did I do the opposite later."

It was nonetheless a productive period for him: films (*Le Lit à colonne* by Roland Tual [1942], *Lettre d'amour* [1942] and *Sylvie et le fantôme* [1945] by Claude Autant-Lara, *Échec au roi* by Jean-Paul Paulin [1943], and *Paméla; ou, L'énigme du temple* by Pierre de Hérain [1945]) and Marcel L'Herbier's play *Au petit bonheur* (at the théâtre Gramont, December 1944) gave him the opportunity to escape from the textile rationing that governed ordinary clothing and to conceive, often for Odette Joyeux, historically inspired costumes full of long dresses and extravagant designs.

After the Liberation, Dior's colleague Pierre Balmain opened his own couture house in 1945 on rue François Ier and encouraged Dior to do the same. Marcel Boussac, a major French textile manufacturer and president of the cotton-marketing syndicate, offered Dior the artistic direction of the Gaston firm (formerly called Philippe et Gaston) on rue Saint-Florentin. Considering the business outmoded, Dior suggested instead that he start a couture house "where everything would be new, from the state of mind and the personnel to the furnishings and the premises," in view of the fact "that foreign markets, after the long stagnation of fashion due to the war, were bound to demand really new fashions." Marcel Boussac invested sixty million francs in the project.

### The House of Dior

In 1946 Dior chose a private mansion located at 30, avenue Montaigne as the site of his own firm, which was established on 8 October 1946. The enterprise had four models and eighty-five employees, sixty of whom were seamstresses. The management team, in addition to the head couturier, included a financial director (Jacques Rouet), a studio head (Raymonde Zehnacker, who came from Lelong), a head of workshops (Marguerite Carré, who came from Patou), and an artistic adviser and head of high-fashion design (Mitzah Bricard, a designer from Molyneux). The couture house itself included two workshops for dresses and one for suits (whose head was Pierre

Cardin, then twenty years old). From the outset, it also had, on the ground floor, a shop selling articles and accessories not requiring fitting. Salons and shops were decorated by Victor Grampierre in tones of white and pearl gray and furnished in neo-Louis XVI style.

The opening was widely publicized: "When the summer 1946 collections came out, everyone was talking about Christian Dior, because an extraordinary rumor was spreading that the financial assistance of Marcel Boussac, the French king of cotton . . . would enable him to create his own house." Even before it was seen, Dior's first collection thus made news, and he won the support of the editors of *Vogue*, *Le figaro*, and *Elle*. The newcomer among couture houses, Christian Dior finally unveiled, at the conclusion of the winter shows, his first collection for spring 1947. Considered the opening shot for the New Look, it immediately gained notoriety for the couturier at the age of forty-two. "The first season was brilliant, even beyond my hopes," he said. The second, in which the couturier carried "the famous New Look line to its extreme," achieved "breathtaking" success and was accompanied by the launch of his first perfume, Miss Dior.

With this impetus, Dior spent the last ten years of his life developing his couture house and extending his influence on world fashion. (In 1955 the Dior firm had one thousand employees in twenty-eight workshops and accounted for half the exports of the French couture industry.) For his first collection, Dior received the Neiman Marcus Award in 1947. From his trip to the United States, he learned, as he put it, that "if I wanted to reach the large number of elegant American women . . . I had to open a luxury ready-to-wear shop in New York." The following year, he set up the subsidiary Christian Dior New York, Inc., at 745 Fifth Avenue. He repeated the process in Caracas in 1953 (Christian Dior Venezuela), in London in 1954 (Christian Dior, Ltd.), and later in Australia, Chile, Mexico, and Cuba. These companies custom-made styles from Paris and sold accessories. But it was not until 1967 that a real line of ready-to-wear was distributed, under the label Miss Dior.

In 1948 the Christian Dior perfume company was set up, and it launched the second fragrance, Diorama, in 1949, followed by Eau Fraîche (1953) and Diorissimo (1956); the first lipsticks came out in 1955. Dior opened a stocking and glove division in 1951 and established the Christian Dior Delman company, which made shoes designed by Roger Vivier; finally, the Paris shop added a gifts and tableware department in 1954. The range of products with the Dior label was enlarged thanks to a very innovative policy for licenses, the first of which was granted in 1949. By this means, the label was attached to all the accessories of female dress, from girdle to jewelry, but also, and very early on, to totally distinct articles, such as Christian Dior Ties (1950).

The growth of the house was fostered by a simple and effective public relations policy: little direct adver-

tising but excellent relations with the press, which guaranteed great visibility for the fashions as well as for their creator (who was featured on the cover of *Time* on 4 March 1957). The couturier gave many interviews, designed disguises for memorable parties (among them, the Venetian ball of Carlos de Beistegui given at the Palazzo Labia on 3 September 1951), and continued to dress stars, such as Marlene Dietrich in Alfred Hitchcock's *Stage Fright* in 1950 and Henry Kosters's *No Highway in the Sky* in 1951 and Ava Gardner in Mark Robson's *The Little Hut* in 1956. In *Christian Dior et moi* (1956), Dior described his career, strewn with Parisian celebrities, pitfalls, coups de théâtre, and palm readers' predictions. In passing, he reassured the reader about the motives for his long-ago trip to the Soviet Union and emphasized his admiration for the entrepreneurial spirit, thus helping to forge the paradoxical myth of the creator of scandals with a reassuring face.

The attention given to the collections was intensified each year by the expectation—followed by the announcement—of a new major change (affecting, notably, the length of skirts). The couturier himself issued descriptive communiqués adopted by the press that frequently took a preemptory tone, such as “No yellow” or “No hats with clean and tailored style,” giving force to the new fashion tendency. The collections, each containing approximately two hundred items, unveiled in succession contradictory lines that imposed on fashion a rate of change never seen before: Corolle and 8 (1947), also known as the “New Look collection”; Zig-Zag and Envol, followed by Ailée (1948); Trompe-l'œil and Milieu de Siècle (1949); Verticale and Oblique (1951); Ovale ou Naturelle and Longue (1951); Sinueuse and Profilée (1952); Tulipe and Vivante (1953); Muguet and H (1954), A and Y (1955); Flèche and Aimant (1956); and Libre and Fuseau (1957).

### La Belle Époque Influences on the New Look

Differing in their lines, his creations were always related to one another through the constancy of certain characteristics. Structurally, the dresses came out of the intention to sculpt the silhouette along predefined lines. Whether it was the New Look, the Shock Look (the English name for the Vivante line), or the Flat Look (the H line), the body was always strongly stylized. The waist was displaced, cinched, or unbelted. The hips swelled or shrank thanks to the choice of materials able to express in shapes the energetic and tense designs of the couturier: shantung, ottoman silk, thick taffetas and satins, velvet, organza, woolen cloth, and cotton piqué generally replaced the customary use of fluid woolen and silk crepes. Originator of a style that used a large quantity of material, artifices, and ornaments, Christian Dior stimulated the growth of a number of parallel industries: corset makers, feather makers, embroiderers, makers of costume jewelry, flower designers, and also illustrators. Thus, the image of the creations of Christian Dior includes the shoes of Roger Vivier, the prints of Brossin de Méré, the

tulles of Brivet, the fabrics of Rébé (René Bégue) and Georges Barbier, the jewels of Francis Winter, and the drawings of René Gruau. As for furs and hats, they were manufactured in specialized workshops of the couture house.

Stylistically, Dior's creations were frequently distinguished by ornaments that came directly from pre-1914 fashion. Simulated knots; false pockets; decorative buttons; play with cuffs, collars, basques, and tails; false belts; and bias cuts punctuated his collections with their trompe-l'œil effects and, from the outset, erased any modernist intentions.

Dior did not specify the origin of his stylistic borrowings. In particular, he expressed only elliptical intentions to justify the inspiration for his New Look: “I have a reactionary temperament, a characteristic that is too often confused with the retrograde; we had barely come out of a deprived, parsimonious era, obsessed with tickets and textile rationing. My dream therefore naturally took on the form of a reaction against poverty.” Hence, it is in the context of the presentation of his shows that we should look for an explicit expression of his historical inspiration. Speaking of the renovation of the mansion on the avenue Montaigne, the couturier asserted that he was striving “to prepare a cradle in the style and the colors of the years of [his] Paris childhood” and described “this neo-Louis XVI, white paneling, lacquered white furniture, gray hangings, glass doors with small beveled panes, bronze wall lamps, and small lamp shades that ruled from 1900 to 1914 in the ‘new’ houses of Passy.” He displayed a “crystal chandelier and a proliferation of palms,” while the shop, on the advice of Christian Bérard, was given a hanging of cloth of Jouy “in the tradition of notion shops of the eighteenth century.”

In parallel with this nostalgic neo-neo-Louis XVI style, a veritable mirroring of pastiche, Christian Dior seemed throughout his career to draw the material artifice of his pleated, draped, corseted, and decorated effects from the clothing vocabulary of the Belle Époque. “I thank heaven that I lived in Paris during the last years of the belle époque . . . whatever life has granted me since then, nothing will ever be able to equal the sweet memory of those days,” he wrote. But by choosing as his favorite period one in which taste was eclectic, the designer avoided the domination of a single style in order to free himself to adopt all possible reinterpretations of the past.

Neither the structural artifices nor the proliferation of appliquéd ornaments interfered with the readability of the line. Paradoxically, Dior's creations attracted primarily through their sobriety. As evidence of an eclectic sensibility, the ornamental resources derived from turn-of-the-century fashion were effectively deployed with a concern for modernity hostile to the composite. The conception of each model seemed to be guided only by emphasis on a single effect at a time. From one model to the next, one's attention was shifted, for example, from



the emphasis of a cut to the shimmering of a pattern or to the luxuriance of the embroidery. The directed gaze, channeled by the erasure of the superfluous—by the notorious choice of uniform and subdued colors when the cut was to be emphasized or, on the contrary, the choice of a simple cut to emphasize the fabric—guaranteed the visual impact of each model and pointed up its strong identity. It thus was beyond the individual model and only in the course of the show that the succession of appearances enabled the presentation of an aesthetic of the whole, both composite and romantic.

The constancy of stylistic borrowings from the past revealed a veritable postmodernist stance on the part of this man who was so admirably ensconced in his century. As Dior himself said:

It is strange that in 1956 people applied the names avant-garde and aesthetic of the future to the works and the masters that we had admired between the ages of fifteen and twenty and who had already been famous for ten years among the most aware of our elders, guided by Guillaume Apollinaire.

But for Dior, “the new at all costs, even to create the absurd, is no longer the essential area of exploration.” Far from the aspirations of prewar surrealism, he confided the origin of his first collections: “After so many years of wandering, weary with consorting with only painters and poets, couture wished to return to the fold and rediscover its original function which is to adorn women and to beautify them.” As a result, his haute couture, while remaining a privilege of the wealthy, appeared comprehensible to everyone. Christian Dior thereby gave his signature to the first democratization of taste, if not of fashion.

By conforming the feminine silhouette to design, by dictating the choice of accessories and the circumstances appropriate for every outfit, the couturier left little room for personal expression, risk, and feminine fantasy. On the other hand, the steadiness of his “total look” guaranteed his popularity. It enabled him to satisfy an enormous public, who saw in Christian Dior, whatever their national or individual clothing cultures, the label of a guaranteed elegance. In the end, Dior’s conception of a wearable fashion was also that of an exportable fashion.

Christian Dior was, in succession, an avant-garde amateur, an artisan of a kind of return to order, and, finally, a manufacturer of elegance. The first superstar couturier, he died of a heart attack at the age of fifty-two in Bagni di Montecatini, Italy. The financier Marcel Bousac thought at the time of closing the house, but in the face of pressure from license holders, he appointed the young assistant Yves Saint Laurent as artistic director, and in this way the label survived its founder. When Yves Saint Laurent left in 1960, Marc Bohan took his place and held it until Gianfranco Ferré took over in 1989. Their designs upheld the image of a couture distanced from the multiple challenges and manifestos of contemporary fashion. The classicism of Christian Dior was not shaken until the arrival in 1997 of John Galliano, who

revived the active media exposure established by Dior himself.

*See also* **Art and Fashion; Balmain, Pierre; Film and Fashion; Galliano, John; Haute Couture; New Look; Perfume; Ready-to-Wear; Saint Laurent, Yves; Theatrical Costume.**

#### BIBLIOGRAPHY

- Cawthorne, Nigel. *The New Look: The Dior Revolution*. London: Hamlyn, 1996.
- Dior, Christian. *Je suis couturier* [I am a dressmaker]. Paris: Éditions du Conquistador, 1951.
- . *Christian Dior et moi* [Christian Dior and me]. Paris: Amiot-Dumont, 1956.
- Giroud, Françoise. *Dior*. Paris: Éditions du Regard, 1987.
- Golbin, Paméla. *Créateurs de modes*. Paris: Éditions du Chêne, 1999.
- Grumbach, Didier. *Histoires de la mode*. Paris: Éditions du Seuil, 1993.
- Homage à Christian Dior 1947–1957*. Paris: Musée des arts de la mode, Union centrale des arts décoratifs, 1986.
- Martin, Richard, and Harold Koda. *Christian Dior*. New York: Metropolitan Museum of Art, 1996.
- Milbank, Caroline Rennolds. *Couture: The Great Designers*. New York: Stewart, Tabori and Chang, 1985.
- Pochna, Marie-France. *Christian Dior*. Paris: Flammarion, 1994.
- . *Dior*. Paris: Assouline, 1996.
- Remaury, Bruno, ed. *Dictionnaire de la mode au XXème siècle*. Paris: Éditions du Regard, 1994.

*Eric Pujalet-Plaà*

**DISTRESSING** Distressing refers to a surface treatment of fabric that makes the material appear faded or wrinkled, as if from long, steady use. In order to obtain good results in distressing, it is important to have a good understanding of the fabric being treated. Necessary information includes the types of fibers that make up the fabric, how the fabric was made (for example, is it woven or knitted), the dyes used to color the fabric, and any other treatments or decorations that the fabric has undergone. Various sorts of fabrics can be distressed, and techniques for each may vary.

The most commonly encountered distressed fabric in modern times is denim. Almost everyone has a favorite pair of jeans whose fabric is worn in all the right places and washed out to the perfect color. Repeated wear may be the only natural way to get jeans just the way one wants them, but there are many ways to distress the denim to instantly create a pair of “worn” jeans. Fabric along the pocket tips may be distressed by using a sander or file to fray the denim until it has acquired the preferred look. The goal is to create wear in the fabric, but without tearing it, in any place where the jeans would normally show signs of wear. Jeans can also be distressed when launder-

ing them by adding some pumice stones to the washer; the effect is enhanced by using cold water and a detergent that contains no brighteners.

Using such methods, it is possible to make a do-it-yourself project of distressing jeans, but most people in the early 2000s prefer to purchase pre-distressed denim. This trend has changed the jeans business, because the cost of worn-look jeans is almost double that of new jeans. This style started catching on in the early 1990s, according to the *New York Times*, when fashionable young Japanese consumers began to seek out used older jeans. The discovery of jeans as antiques quickly created a market for “antique-look” jeans, which manufacturers were happy to supply. Pre-distressed denim is processed with bleach and potassium permanganate, tumbled with pumice stones, and digested with enzymes.

Techniques of distressing fabric have existed long before the fad of distressed jeans, however. Theatrical costume designers have been using distressing techniques to make costumes more believable for many years. Distressed fabric is often used in costumes for movies, TV shows, and theatrical productions. Almost every movie wardrobe is likely to include at least one garment made from distressed fabric. Costume designers for westerns, horror films, and other film genres pioneered the techniques of fabric distressing that have come to be used in fashionable clothing in the early twenty-first century.

See also **Denim; Jeans.**

#### BIBLIOGRAPHY

Russell, Douglas. *Stage Costumes Design*. New York: Prentice-Hall, 1973.

#### Internet Resource

Family Education Network. 2004. “Distressed.” Infoplease.com Dictionary. Available from <<http://www.infoplease.com/ipd/A0411265.html>>.

*Alicia R. McClain*

**DJELLABA** Human clothing is about society and about culture. It communicates social standing, group identity, cultural values, gender, religion, cross-cultural influences, political resistance, and more. It can yield meaning at the material, the symbolic, and the sociocultural levels. Arab-Islamic clothing is no different. Not equally common among all cultures, however, is the fact that Arab culture has developed between a crossroads of cultures, empires, and civilizational developments since antiquity. Trade, contact, and conquest brought and spread diverse influences including clothing styles that enriched and diversified Arab dress forms and clothing vocabulary and their uses. Arab clothing serves in multiple ways, has various symbolic functions, and yields complex meanings in secular and religious settings. Despite cross-cultural and cross-ethnic similarities, certain symbolic and func-

tional attributes and cultural nuances in usage and practices make Arab-Islamic clothing unique.

The word *djellaba*, or *jillaba*, refers to one of three related terms used in Arabic for a garment variably worn by men, by women, or by both. They are *jilbab*, *jillaba*, and *gallabiyya* (or *jallabiyya*)—the “g” consonant is characteristic of Egyptian Arabic and a few other spoken Arabic forms in different parts of the Arabic-speaking world. The verb derivative *jallaba* or *tajallaba* means to clothe or be clad in a garment, used in material or metaphoric terms. The *djellaba* connotes a mid-calf or (most commonly in the early 2000s) ankle-length, loose-fitting, shirtdress or garment worn in different Arab societies and among other Islamic groups. In most cases, it would be made of cotton, although less commonly of silk or wool fabrics. The garments referred to by the related terms *jilbab*, *jillaba*, and *gallabiyya* are similar in form and are worn as traditional secular garments throughout the region but acquire special meaning when applied to contemporary Islamic context.

In the contemporary Arabic usage, *jilbab* refers to a full-length, loose shirtdress and does not in itself connote head or face cover. In Morocco *jillaba* is the word used to refer to the long, hooded robe worn as an outer garment by both sexes. When hooded it is commonly referred to in Maghrebi societies (Arab societies of North Africa) as *burnus*. Neutral or dual-gendered dress among Arabs is not associated with unisex identity, behavior, or attitude. Even when similar or identical in form, dress items are “worn” differently by women and men, who carry themselves differently in ways that are culturally understood. Differences between culturally defined femininity and masculinity is seen in gait and body language evident even when both sexes wear identical garments.

It is significant to stress that men, not only women, in traditional Arab culture and in Islamic societies practice “veiling”—head and face covering. Islam and traditional Arab culture are concerned with clothing forms for both sexes, and that includes head and face covering for men and women. A systematic study (El Guindi) points to the importance of clothing, including veiling, for men and how, contrary to popular misconceptions, the Hadith sources point to the disproportional attention given by Prophet Muhammad during Islam’s early days of community formation in the seventh century, to men’s modesty in clothing and public behavior in comparison to women’s. To fully understand Arab and Muslim dress, sartorial practices by both sexes must be examined.

Clothing is of special significance for Muslims because Islam prescribes a code about privacy-reserve-sanctity, which applies to cultural notions of body, dress, home, womanhood, and sacred space. In application, the code extends beyond body covering to general comportment and public behavior and applies to the notions of home, womanhood, and family (*bayt*, *haram*) and house of worship (*bayt al-haram*). Islam is specific about the extent of

body coverage for Muslim men and women in times of worship and in sacred spaces. It is less specific when it comes to ordinary life. The phases in an individual Muslim's life cycle are clearly marked by specific rites, all of which involve a sociomoral code that translates through clothing forms in sacred time and space, such as during daily prayer and during the annual pilgrimage (the *hajj*). The latter consists of a complex set of rites during the individual's pilgrimage in Mecca, much of which involves the body and how it is clothed.

The term *jillaba* is henceforth used in a generalized way to refer to both a traditional (secular) garment worn by men and women, and also to women's and in some cases men's garment as part of the overall contemporary Islamic dress (*libas shar'i* or *ziyy Islami*) revived during the mid-1960s in the Islamic world. In its beginnings, Islam did not introduce new clothing forms. There was continuity in dress forms from the earlier period in Arabia that extended into the period of formation for the Umma (Islamic Community) in the seventh century. Clothing style was, however, influenced by new ideas emerging and new meanings rendered during Islam's early days.

Among these were concerns about marking group identity, distinguishing the status of the Prophet's wives, protecting the moral integrity of Muslim women, and establishing a sociomoral code for public behavior of Muslim men and women. References to clothing for both sexes reflected these concerns. There was a stress on a general comportment of reserve. Men's clothing was to be austere and modest, layered during worship and prayer to prevent body exposure when bending and prostrating.

With regard to women, the Qur'an mentions two clothing items: *khimar* and *jilbab*. Reference to these two is found in poetry and other literary forms as evidence of their use in pre-Islamic society. With the birth of Islam, special significance was given to them. References in the Qur'an regarding these two clothing items are specific. First, consider the reference to *khimar*. The most cited is Sura (chapter) 24 that refers to *khimar* (women's head cover) in the general context of public behavior and comportment by both sexes. This passage implies that women are singled out for "reserve" and "restraint." This selectivity also distorts Islam's intent by the Sura. Preceding this, is a sentence which addresses men first about "reserve" and "restraint" translating thus: *Tell the believing men to lower their gaze and conceal their genitals; for that is purer for them, God knoweth what they do.* The following sentence continues the same theme: *And tell the believing women to lower their gaze and conceal their genitals, and not reveal their beauty, except what does show, and to draw their khimar over their bosoms, and not to reveal their beauty except to ....* (emphasis added).

*Jilbab* is mentioned in Sura 33:59, which enjoins the Prophet's wives, daughters, and all Muslim women to don their *jilbab* so they are easily recognized and protected from molestation or harassment. It translates as follows:

O Prophet tell your wives, daughters and believing women to put on their jilbabs so they are recognized and thus not harmed (33:59).

*Jilbab* refers to a long, loose shirtdress. It does not in itself connote head or face cover. However, cross-cultural ethnography and Islamic references point to the practice by which these and similar outfits (referred to by different terms) can be physically manipulated in different social situations to cover head or face. Examples can be found among the Rashayda Bedouins of the Sudan, Muslim rural Indian women, and elsewhere. A systematic study on dress of women and men in Arab-Islamic culture (El Guindi) reveals a pattern of flexibility and fluidity in the manner by which women and men use clothing to cover face and head. Long, wide sleeves are often used to cover the head and face, and head covers to cover face. Some clothing items are inflexibly used in a single way, but other items are fluidly used in multiple ways, to cover and uncover, tighten or loosen. The face veiling by the men in the Berber group, the Tuareg, is only for face covering but is manipulated fluidly. Such complex, nuanced movements that communicate different messages about rank, gender, and identity characterize men's face-veiling behavior.

In the several-decades-old contemporary Islamic movement in Egypt and subsequently the rest of the Arab region, *hijab* is used to refer to women's Islamic head cover. However, it also referred to the general Islamic attire for women composed of at least two items, body cover and head cover. Similarly, in Indonesia *jilbab* became commonly used to refer to women's overall Islamic dress. Like the Arabic usage *hijab*, *jilbab* in Indonesia sometimes refers to head covering only and sometimes to the entire Islamic outfit that includes garment and head cover.

There is a language underlying dress usage and meaning derives from the social and cultural contexts of dress and movement and manipulation of dress items in particular situations. Often focusing analysis on the code underlying dress forms can prove more revealing than exploring a clothing item in material and functional terms. Other than its religious dimension, clothing for Arab and Muslim women and men cannot be reduced to a material element with utilitarian functions. It reflects a core code of privacy, functions to communicate status and identity, and even when identical in form for both sexes it communicates gender boundaries. It is intricately connected with historical situations of resistance to foreign occupation and against European ideals and Eurocentric images imposed through state or colonial sartorial rules and restrictions on people's choices of dress.

See also **Hijab; Iran: History of Pre-Islamic Dress; Islamic Dress, Contemporary; Middle East: History of Islamic Dress.**

#### BIBLIOGRAPHY

Brenner, Suzanne. "Reconstructing Self and Society: Javanese Muslim Women and 'The Veil.'" *American Ethnologist* 23, no. 4 (November 1996): 673-697.



El Guindi, Fadwa. *Veil: Modesty, Privacy, and Resistance*. Oxford and New York: Berg, 1999.

Young, William C. *The Rasbaayda Bedouin: Arab Pastoralists of Eastern Sudan*. Fort Worth, Tex.: Harcourt Brace College Publishers, 1996.

*Fadwa El Guindi*

**DOLCE & GABBANA** Domenico Dolce was born in Polizzi Generosa (near Palermo, Sicily) on 13 September 1958. His family owned a small clothing business, where Domenico worked from childhood. Stefano Gabbana was born in Milan on 14 November 1962. He studied graphics but soon turned to fashion. After a brief period working as assistant designers, they founded the Dolce & Gabbana label, which had its first runway show as part of the New Talent group in Milan in 1985, upon the invitation of Italian fashion promoter Beppe Modenese.

In 1986 they produced their first collection, called “Real Women.” In 1987 they launched their knitwear line and in 1989 their beachwear and lingerie lines. Beginning in 1988 they produced their ready-to-wear line in Domenico Dolce’s family-owned atelier, located in Legnano, Milan. The first Dolce & Gabbana men’s collection appeared in 1990. In 1994 they launched the D&G label, inspired by street style and a more youthful look. The clothes were produced and distributed by Ittierre.

The company launched several fragrances, including Dolce & Gabbana Perfume, By Dolce & Gabbana, and Dolce & Gabbana Men. One of their perfume ads was directed by the Italian film director Giuseppe Tornatore, with whom Dolce and Gabbana developed a close relationship, going on to act in his 1996 film *The Star Maker*. They introduced a line of eyewear under the Dolce & Gabbana and D&G labels and produced music CDs.

In 1996, for their tenth anniversary, they published *Ten Years of Dolce & Gabbana*, which included their most important advertising images and texts. In 1999 D&G Junior was created, their collection for children, which was presented at the children’s fashion show Pitti Bimbo in Florence.

In 2003 their newest store, covering three floors, opened in Corso Venezia in Milan, in the former home of Brigatti, perhaps Milan’s best-known luxury sportswear store. The store is designed in the round from a central piazza and includes a bar, a traditional barbershop, and an ultramodern spa. The individual stores are illuminated by lamps of Venini glass, made according to designs by Domenico Dolce.

In a 1995 interview Dolce and Gabbana recalled their first professional foray into fashion during the Milan collections as eliciting “one of the strongest emotions we have ever experienced” (Gastel, p. 238). The show marked the occasion of the birth of the Dolce & Gabbana label, which was destined to play a fundamental role in the history of Italian ready-to-wear. The designers



**An advertisement for Dolce and Gabbana, circa 2001.** Dolce and Gabbana's 2001 collection celebrated the exuberance of youth street style and rock and roll culture. THE ADVERTISING ARCHIVE LTD. REPRODUCED BY PERMISSION.

showed full-length garments of stretch jersey, silk jackets, and oversize shirts that could be worn with casual sandals. The collection, characterized by fluidity and difference, soon found an enthusiastic public.

Dolce and Gabbana are considered the inventors of a Mediterranean style that draws its inspiration from the Sicily of Luchino Visconti’s 1963 film *The Leopard* and the women of Italian realism, sensual and austere like Anna Magnani, to whom they dedicated a collection whose key element was the 1940s slip. At the beginning of their career, the designers also turned to Sophia Loren, Claudia Cardinale, and Stefania Sandrelli for inspiration. The Dolce & Gabbana woman is unbiased and brazen, but fearful of God and devoted to church and family, an attitude typical of southern Italian Catholicism. A woman who simultaneously reveals and conceals brassieres and corsets, lace, lingerie, and veils, and who is disturbing in her impetuous sensuality—a provocative woman proud of her body. The designers’ models are soft, round, and full-figured. “Dark girls with dark eyes evoke the women of the south—carnal, provocative, yet austere and proud at the same time” (Sozzani, p. 5). At a time when fashion saw women as executives in two-piece suits with padded shoulders, Dolce & Gabbana’s first collection in-



**Domenico Dolce and Stefano Gabbana.** Dolce and Gabbana promote their fragrance “Sicily,” at Saks Fifth Avenue in New York City in 2003. AP/WIDE WORLD PHOTOS. REPRODUCED BY PERMISSION.

cluded tulle and angora, twin sets in jersey lace, and soft, wide, extravagant skirts. Their favorite materials were crocheted lace, wool, and silk.

They were not looking for a retro look; however, Dolce & Gabbana turned to the past for innovation. The designers remarked, “We want to use the past to project it into the future” (Sozzani, p. 11). And making it modern involved the creative use of fabrics and colors, and the ability to blend various sources of inspiration, primarily those whose origins could be traced to the heterogeneous world of the Mediterranean.

The elements of Italian culture are reinforced through their meticulous attention to their image, and their publicity campaigns have always been handled by the world’s finest photographers. Every shot is organized as if it were a film set. Their first campaign was photographed by their friend, the Sicilian photographer Ferdinando Scianna, who, with Dolce and Gabbana, was just getting started in fashion. Besides Scianna, other photographers who have worked with the label include Fabrizio Ferri, Steven Meisel—famous for his pictures of the Italian film star Monica Bellucci and the supermodel Linda Evangelista—Peter Lindbergh, and Helmut Newton.

The journalist Nicoletta Gasperini of *Donna*, the Italian fashion weekly that gave them their first cover—the model Marpessa photographed by Giovanni Gastel—helped define their image. “We convey to them how we feel and they give us back a mediated image of culture” (Gastel, p. 241).

The turning point in their international success began with their friendship with Madonna. The pop star ordered from their New York showroom a *guêpière* (corset) made of gemstones and a jacket to wear at Cannes to launch her film *Truth or Dare: In Bed with Madonna* by Alek Keshishian (1990). Madonna’s participation in the 1992 D&G party and runway show publicized their friendship. Shortly after, the singer asked them to design the fifteen hundred costumes for her 1993 “Girlie Show” tour.

Dolce & Gabbana’s Mediterranean style is not a rigid framework but the template of an imaginary world through which they draw inspiration. The collection changes for every season, ranging from the baroque to the plastic, from aristocratic to working class, brazen to bourgeois, from animal prints to a cardinal’s cloak. In 1994, for example, after producing corsets, girdles, T-shirts, and styles emphasizing breasts and revealing cleavage, Dolce & Gabbana introduced a “Sapphic chic” masculine style for women characterized by short hair slicked down with brilliantine, which was exemplified by one of their earliest fans, Isabella Rossellini. In 2003 for their Milan men’s show, they took their inspiration from contemporary soccer stars. The darlings of the Italian and international press, according to Suzy Menkes, a journalist for the *International Herald Tribune*, the two designers have the ability of being able to mix periods and countries, masculine and feminine looks, fabrics and styles.

Dolce & Gabbana is one of the best examples of the explosion in Italian ready-to-wear that occurred during the mid-1980s. Creativity and versatility, the union of the press and the star system, a range of products and clothing lines, and careful attention to distribution are all elements that contribute to the realization of an integrated system of communication.

See also **Italian Fashion; Madonna; Music and Fashion.**

#### BIBLIOGRAPHY

- Asnagli, Laura. “Dolce & Gabbana.” In *Dizionario della Moda*. Edited by Guido Vergani. Milan: Baldini and Castoldi, 1999.
- Gastel, Minnie. *50 anni di moda italiana*. Milan: Vallardi, 1995.
- Sozzani, Franca. *Dolce & Gabbana*. Translated by Marguerite Shore. New York: Universe Publishing/Vendome Press, 1998.

*Simona Segre Reinach*

**DOMESTIC PRODUCTION** The idea of a Golden Age of self-sufficiency, before the advent of the factory system, when a household’s skills and labor in

domestic production could account for all its clothing and textile needs, is more nostalgia inspired by anti-industrial sentiment than a historical reality. In the modern period, working women and men formed a labor force that was interchangeable between small workshops and the home and domestic self-employment and outwork. Handicraft and mechanized mass production coexisted and developed differently in different regions and for different goods. For example, in the early nineteenth century some goods such as knitted hosiery were still commonly sent out to be made by hand on a cottage basis, while the spinning and weaving of cotton were already widely mechanized and centralized in factories. The history of home production of some kinds of clothing and textiles is evident in surviving architecture such as weavers' houses. The timetable of the move to factory production for all goods was complex and generally much debated by historians. In practice, before the domination of mass-production of clothing for men and women was completed in the early twentieth century, households were clothed by a combination of making, recycling, bartering, and buying new or secondhand from a variety of sources.

### Sewing

Clothing for women and children, and some simple items for men such as shirts, were made in many homes across the social spectrum in modern times for private consumption. This has been concurrent with clothing made at home in poorer homes for wages in a regular or irregular way as self-employment or outwork. Both practices have existed alongside the increasing consumption of factory ready-mades, a situation that prevails in the early 2000s, although unwaged home dressmaking has substantially declined. Not all domestic production has been prompted by thrift or economic necessity: women have also sewn clothes for pleasure and as a creative act and in this same period skill with the needle has been prized for its association with leisure and femininity. In the eighteenth and nineteenth centuries, the domestic production of clothes also embraced the efforts of literate, middle-class women to teach their peers to make clothes for the deserving poor or to teach poor women to sew for themselves. The trend was reflected in a new genre of instructional literature, such as an 1838 publication called *The Workwoman's Guide*. Although philanthropic in some respects, this activity also served to provide a flow of skilled girls into domestic service. The introduction of reliable domestic sewing machines in the 1860s, for those who could afford them, accelerated home production of garments for both waged and unwaged purposes, as did the spread of well-illustrated mass part-works, books, magazines, and paper patterns that increased through the nineteenth century and helped to disseminate knowledge of home sewing, knitting, embroidery, and other handicrafts associated with clothing such as crochet. Home sewing included significant time spent on mending and renovation, in all



"[M]any women who have started home dress-making as a means to economy have continued it as a[n] . . . . adventure in creative expression . . . . These days the only way to stamp one's individuality on a wardrobe is to make one's own . . . ."

"[Y]ou don't have to be an expert to make a chic dress" (Butterick Publishing Company, pp. 2–3).

classes of household. "Make-do and Mend," a campaign introduced by the British government during World War II, encouraged clothing economies in the home at a time of acute shortages. It promoted many ingenious solutions but was not universally popular; it may have unintentionally contributed to the postwar move away from thrift to more throwaway attitudes to clothing. Home sewing was regularly taught to girls in schools until the last quarter of the twentieth century when it was replaced by other courses that emphasized design and new technologies.

### Knitting

Domestic hand knitting had been known for centuries as a convenient way of making shaped garments, especially smaller items such as hosiery and caps. Its precise origins are conjectural, though many believe otherwise. Historically, both men and women knitted, but it became a gentrified and fashionable pastime primarily for women during the first half of the nineteenth century in Britain and America. The craft was promoted by the publication of countless knitting books and helped by a ready supply of fancy wool yarns from Germany, from which also developed the hugely popular tapestry work known as "Berlin" work. Domestic knitting of this period produced a wide variety of small household objects such as pin-cushions, purses, and doilies, as well as shawls, baby clothes, cuffs, caps, scarves, gloves, and numerous other items of clothing. Domestic knitting was undertaken for items used in the household but also given as gifts and for charity. Knitting for the troops in both world wars was a continuation of this altruistic knitting practice, still seen in hand knitting for fund-raising or for distribution to developing countries. This strand of its history is distinct from the long history of small-scale commercial hosiery knitted by cottagers and the frame knitters, first incorporated in England as a worshipful company in 1657, whose mechanical knitting did not entirely replace commercial hand knitting for two hundred years. Mass-production of cheap knitwear has come to mean that "no one needs to knit in order to keep clothed" (Rutt p. 161). Hand knitting at home is a leisure activity and, since the



1970s, has become more glamorous due to innovative design and exciting yarns.

### Embroidery

Embroidery has a long history and, despite male practitioners, and a substantial role in the decoration of ecclesiastical vestments and furnishings, it has been closely linked to the domestic lives of women. "To know the history of embroidery is to know the history of women" (Parker p. vi). It has been used on small and large scale furnishing fabrics and on male and female clothing to great impact since medieval times in Europe. Samplers have been a way to demonstrate skill and catalog the rich range of stitches and effects available to embroiderers; historic samplers have become much appreciated and command high prices. Some feminist historians have identified embroidery, even more than other needlework, as a repetitive and repressive task promoted historically to construct a submissive femininity within patriarchy. However, in the early 2000s it is also widely acknowledged as an important textile art, an expressive and satisfying medium in its own right. Embroidery was famously represented in the feminist artist Judy Chicago's 1979 project *The Dinner Party*. It sustains large numbers of specialist publications, courses, and suppliers of yarns, kits, and patterns, and has enjoyed popularity as a way to customize mass-produced clothes such as jeans. In some developing countries, embroidery for export can represent a crucial source of cash for families and has replaced much domestic embroidery formerly done in richer countries.

See also **Embroidery; Knitting; Seamstresses.**

### BIBLIOGRAPHY

- Buck, Anne. *Dress in Eighteenth Century England*. London: B. T. Batsford, Ltd., 1979.
- Burman, Barbara, ed. *The Culture of Sewing: Gender, Consumption and Home Dressmaking*. Oxford and New York: Berg, 1999.
- Butterick Publishing Company. *Making Smart Clothes: Modern Methods in Cutting Fitting and Finishing*. New York and London: Butterick Publishing Company, 1931.
- Byrde, Penelope. *A Frivolous Distinction: Fashion and Needlework in the Works of Jane Austen*. Bath City Council, n.d.
- MacDonald, Anne. *No Idle Hands: The Social History of American Knitting*. New York: Ballantine Books, 1990.
- Parker, Rosika. *The Subversive Stitch: Embroidery and the Making of the Feminine*. London: The Women's Press, 1984.
- Rutt, Richard. *A History of Hand Knitting*. London: B. T. Batsford, Ltd., 1987.
- Ulrich, Laura. *The Age of Homespun: Objects and Stories in the Creation of an American Myth*. New York: Alfred A. Knopf, 2001.
- Weissman, Judith, and Wendy Lavitt. *Labors of Love: America's Textiles and Needlework, 1650–1930*. New York: Wings Books, 1994.

Barbara Burman

**DOUBLET** The doublet is a man's upper body garment that was worn in Europe between the fourteenth and seventeenth centuries. In this time frame, it moved from undergarment to outer garment and from specialized military dress to fashionable civilian dress. The doublet's function as standard everyday attire was primarily to support men's hose, while providing warmth and shaping a man's upper torso. It was used to display appropriate decorative and stylistic features through each period, such as padding, paning (panes or narrow strips of fabric sewn over a contrasting lining), and slashing (pattern of deliberate cuts made in garments as a decorative feature), and it was one of the first garments to display highly technical construction and sophisticated cutting and tailoring skills after the Middle Ages.

### Origins

The doublet originated in the late thirteenth and early fourteenth century as part of military dress, closely related to technological advancements in armor. By the end of the thirteenth century, as chain mail was replaced by plate armor, a layer of padding was needed to protect the body from abrasion by the tightly fitted, sharp-edged metal plates. Quilted undergarments and leather tunics were long used by soldiers as protection and under chain mail, but the early doublet, called a *pourpoint* or *gipon* (also *jupon*; and in Italian, *giubbetto*, *zuparello*, or *zuppone*), was a closely fitted undergarment heavily padded in front over the chest and quilted around the back. Worn over a loose linen undershirt and short linen drawers, the *pourpoint* was sleeveless, had a round neckline, and was closed down the center of the front using laces or numerous buttons. The padding gave extra definition to the silhouette of the upper torso and shaped outer garments. Length varied, but the French term *pourpoint* also explains an important functional aspect of this garment. Translated as *pour les points* or "for the points," laces held up a man's hose by tying them to the doublet through pairs of hand-sewn eyelets in the tops of the hose and in corresponding eyelets along the doublet's lower edge. The leather laces were capped with small metal tags or "points" at each end, giving the defining name to this garment.

### Late Fourteenth Century

After the mid-fourteenth century, the doublet was worn as a belted outer garment, serving a more fashionable function in civilian dress. Doublets were sleeveless or worn as a type of sleeved jacket, some with skirts extending over the upper thighs, shaped with a tightly tapered fit through the waistline. The points were attached to the inner lining and tied to the hose at the hips. Doublets became increasingly shorter through the second half of the fourteenth century, barely covering the hips, and many had full-length sleeves, ending below the wrist in a point over the knuckles and tightly fitted with a row of buttons from elbow to wrist. The narrow, two-part sleeves were seamed at the elbow and

set into wide, round-shaped armholes for full arm movement. Low, rounded necklines had short standing collars. By the end of the fourteenth century, as an outer layer of dress, the term “doublet” replaced *pourpoint* or *gipon* in general English usage, while *pourpoint* continued in French.

### Fifteenth Century

By the beginning of the fifteenth century, images show young knights in public without their armor, dressed in short, waist-length, padded and fitted doublets with full hose laced to their lower edges. This look eventually inspired a new body-dominant fashionable silhouette for civilian men. As the doublet shortened and more of a man’s upper leg was exposed, construction of hose changed by joining two separate stockings into one garment that closed or overlapped in front with laces or a codpiece. The look of the doublet as outerwear also makes a visual reference to the dress of rural and urban laborers who often removed their outer tunics to work in underwear and hose. Images show laborers with their hose loosened and unfastened in back to relieve strain on the doublet when bending over to work. The need for this feature was a sign of low status. The expression “in zuppone” was equivalent to our contemporary reference about the informality of taking off one’s business suit jacket and working in one’s shirt sleeves.

In the first half of the fifteenth century, the doublet remained a short, waist-length garment with sleeves worn over a linen undershirt and layered under a jacket or outer tunic-like garment. The sleeves and collars were often the only visible portions of the doublet. By mid-century, the silhouette was pared down, more slender and elegant, and the waist-length doublet was expertly constructed and tightly fitted with four seams—down the front, back, and sides. Collars were removed and necklines lowered and squared-off. The center front was often open or slightly unlaced, revealing the edges of the linen shirt underneath, a feature that became more prominent through the end of the fifteenth century. Doublets that showed no front openings may have been pulled on over the head. At the end of the fifteenth century, detachable sleeves appeared or tightly fitted sleeves were slit at the elbow and along the forearm to allow movement.

### Sixteenth Century

In the sixteenth century, the doublet was a major men’s garment covering the upper torso from neck to waist. It was tightly fitted with low, U- or V-shaped necklines and wide sleeves, and was constructed with panes or slashing of heavy velvet or satin fabrics. Doublets were worn under the man’s jerkin or gown, but no longer served the function of supporting a man’s hose. Instead, breeches and stockings were sewn together; the top of a man’s breeches was held up with silk or linen laces at the doublet waist. Some doublets were cut with short, gored skirts, or worn with the separate military skirt called

bases. By mid-century, necklines were higher on the throat, and by century-end doublets had a stiff, standing collar to support the ruff. Doublet waistlines were lowered in front, and the elongated wool, bran, horsehair, or short, waste linen fibers, V-shaped waistline was padded and stuffed with wool, bran, horsehair, or short linen fibers by the end of the century, imitating the exaggerated style called a peascod belly. Layers of stiff linen canvas were stitched together to create the doublet front, and extra layers of stiffened linen strengthened the front button closure. Doublet waistlines were further accentuated with a row of small square flaps called pécadils. Doublet sleeves were padded with felted woolen cloth at the shoulders, and shoulder seams were constructed with a narrow wing or padded roll over the top.

### Seventeenth Century

The padding and exaggerated features of the doublet were gradually abandoned in the first quarter of the seventeenth century, but the narrow-waisted silhouette remained. Through the 1630s, ribbon points tied into bows at the waist were used as a decorative feature. In the second quarter, the overlapping pécadils, or short peplum, lengthened to cover the hips, and waistlines were set slightly above the natural waistline. Heavy fabrics richly embellished with silk and metallic embroidery lend a stiff, formal silhouette to portraits in the early to mid-seventeenth century. By 1620, breeches were suspended from the doublet by large metal hooks sewn into their waistband and attached to metal eyelets on a tape sewn into the doublet waist. By the early 1660s, doublets were straight, unfitted, and shortened to above the waist; breeches were no longer tied to the doublet at all. By 1670, the doublet had been replaced by the waistcoat and coat of the three-piece suit introduced by the British monarch Charles II.

See also **Breeches; Hosiery, Men's.**

### BIBLIOGRAPHY

- Arnold, Janet. *Patterns of Fashion: The Cut and Construction of Clothes for Men and Women, c. 1560–1620*. London: Macmillan, 1985.
- Byrde, Penelope. *The Male Image: Men's Fashion in Britain, 1300–1970*. London: B. T. Batsford Ltd., 1979.
- de Marly, Diana. *Fashion for Men: An Illustrated History*. London: B. T. Batsford Ltd., 1985.
- Frick, Carole Collier. *Dressing Renaissance Florence: Families, Fortunes, and Fine Clothing*. Baltimore: John Hopkins University Press, 2002.
- Herald, Jacqueline. *Renaissance Dress in Italy, 1400–1500*. Edited by Aileen Ribeiro. Atlantic Highlands, N.J.: Humanities Press, 1981.
- Payne, Blanche, Geitel Winakor, and Jane Farrell-Beck. *The History of Costume: From Ancient Mesopotamia through the Twentieth Century*. 2nd ed. New York: HarperCollins Publishers, Inc. 1992.

Tortora, Phyllis G., and Keith Eubank. *Survey of Historic Costume: A History of Western Dress*. 3rd ed. New York: Fairchild Publications, 1998.

Waugh, Norah. *The Cut of Men's Clothes: 1600–1900*. New York: Routledge Theatre Arts Books, 1964.

Susan J. Tortore

**DOUCET, JACQUES** Claiming to have been established in Paris in 1817, the House of Doucet reached its greatest prominence under the design influence of the founder's grandson, Jacques Doucet (1853–1929). While many members of the Doucet family were involved in various aspects of the apparel and related trades, the fashion house of Doucet can be traced to Antoine Doucet (1795–1866) and his wife (née Adèle Girard, d. 1866), who began as vendors of items of lingerie, laces and embroideries, and related merchandise for customers of all ages and both sexes. In 1869 the haberdashery aspect of the business was sold. By 1840 the firm had been established on the rue de la Paix, an increasingly important shopping street, and the second of the couple's six offspring, Edouard (1822–1898), was taking an increasing role in the business. Edouard Doucet, Jacques's father, took the firm over in the early 1850s.

Surviving from the last third of the nineteenth century are a number of stylish garments carrying the label of Mme. Doucet, 21, rue de la Paix. (With the renumbering of streets, the old address number of 17 became the new 21.) What is unclear is who might be behind the courtesy title "Mme.," as Adèle was deceased, and there is no indication that either her daughters or daughters-in-law were involved in business at this address. Beginning in 1858 Maison Doucet is listed in a business directory under the category of "*nouveautés confectionnées*," and by 1870 Edouard was supplying the queen of Wurtemberg with couture garments. Royal commissions, awards at numerous international exhibitions, actress modeling and patronage, and a long-established association with a highly desirable and valued material, lace, assured interest from a wide client base at Maison Doucet. During the house's peak, Jacques Doucet's personal friend, the well-known actress Réjane, became a one-woman advertising vehicle for the house.

Jacques, who was born on the rue de la Paix and died in Paris, grew up in the family business, which he appears to have joined in 1874. While Jacques Doucet is generally credited with being the house's designer, there is enough evidence to question the scale of such a role. As late as 1894 fashion correspondents do not give readers a clue as to whether they are dealing with the elder or younger Doucet, believing that readers are versed in the knowledge of who indeed is "Doucet, the famous dressmaker." Additionally, M. José de la Peña worked at the house as a fitter and designer from the 1870s into the 1920s. Another designer of the time, Paul Poiret, saw



flashes of brilliance in de la Peña's fingers that were unmatched by the house's titular head.

There is no question that Jacques Doucet was interested in apparel and what visual message it could convey. He was a fastidious personal dresser, and he happily applied aesthetic judgments not only to the garments made by the house that bore his name but also to the historic garments he personally collected. Indeed, he was one of the greatest art connoisseurs of his day, first establishing an internationally recognized collection of eighteenth-century artifacts and then a second remarkable collection of modern art. Garments carrying the Doucet name frequently incorporate an historical fashion reference or two, particularly to the modes of the eighteenth century. For decades, the prevailing taste for festoons of lace was sympathetically incorporated by the house into a variety of creations. Embroideries, especially floral and insect interpretations, frequently were executed in prevailing styles, such as art nouveau. Moreover, many of the garments were executed in more fluid fabrics than is usually associated with applications in such decades as the 1880s or 1890s.

As a promoter of fashions Jacques Doucet is best recognized for endorsing delicate, feminine toilettes featuring laces and other fripperies, but the house has also been credited with creating one of the enduring staples of a woman's wardrobe, the tailored suit or *tailleur*. Another innovation accorded Doucet is that of working with furs as if they were fabric, specifically making fitted coats. Doucet garments were popular with American clients, and by 1895 American merchants were busily buying models to export and copy. By the end of the nineteenth century the couture house was one of the largest in Paris, with a yearly turnover in business of more than thirty million francs. Between 1896 and 1912 it was the training ground for two of the emerging and talented young designers who would go on to define fashion in the early twentieth century: Paul Poiret, who worked for Doucet from 1896 to 1900, and Madeleine Vionnet, who worked there from 1907 to 1912. Vionnet's first collection is said to have been revolutionary not only for the house but also the time. Interestingly, but for very different reasons, neither Poiret's nor Doucet's houses productively survived World War I. Initially Jacques Doucet had had the luck to land in a period of fashion that perfectly matched his own design sensibilities. The Great War changed not only what women wore, however, but also how they wore it, and the aging Doucet simply could not keep up with the times. In 1924 the house merged with the lesser firm of Doueillet, and the combined firms ceased business in 1932.

See also **Lace; Paris Fashion; Poiret, Paul; Vionnet, Madeleine.**

#### BIBLIOGRAPHY

Coleman, Elizabeth A. *The Opulent Era: Fashions of Worth, Doucet, and Pingat*. New York: Thames and Hudson, Inc., 1989.

*Elizabeth Ann Coleman*

**DRESS CODES** Dress codes may broadly be defined as rules that regulate an individual's appearance. Sociological variables—age, occupation, class, gender, religion, or ethnicity—stipulate what can and cannot be worn. However, most people probably have a narrower, more specifically modern understanding in mind of dress codes. This stricter definition is associated with a massive uniformization of populations that began in the early nineteenth century as workers and students were disciplined to meet the demands of capitalism, industrialization, and national state formation.

Dress codes, whether explicit or implicit, may apply to small groups (for example, school or company) or an entire nation (China's "Mao suit"). Besides mandating what should be worn, dress codes dictate what should not be worn, and they can be better appreciated by conceptualizing a continuum of uniformity, ranging from strict integration into a politico-economic order to being free from its constraints. Some of the variations are as follows:

- highly standardized, group-dominated, clear hierarchy (military uniforms);
- standardized, group-oriented, hierarchy (occupational dress);
- nonstandardized, displays individuality, no hierarchy (casual dress); and
- anti-standardized, overly individualistic, anti-hierarchy (avant-garde fashion).

As an example of how politico-economic institutions regulate daily dress codes, consider how the life cycle of most individuals in Japan is characterized by uniformization, de-uniformization, and re-uniformization. During the first phase (ages 3–18), individuals begin to don school-specific uniforms that have been inspired by European military uniforms. Boys are outfitted in a blue or black jacket with brass buttons and stand-up collar. Girls often wear the *sêrâ-fuku* ("sailor clothes"), modeled after the traditional English sailor suit. It consists of a sailor-type collar and a pleated skirt. During the second phase of de-uniformization (ages 18–22), the dress code is relaxed as students are allowed to dress casually while at university or other postsecondary schooling institutions. The final phase, re-uniformization (ages from 22), begins after leaving postsecondary schooling and entering the adult workforce.

Inducted into Japan's corporate culture, individuals are required to adopt dress codes that reflect socioeconomic class and gender variables. White-collar male workers, or *savarîman* ("salary man"), are expected to don a white cutter shirt, red necktie, dark blue or gray suit, and black leather shoes. Hair should be short, preferably in the "seven-three part." Facial hair is generally frowned upon. Accessories complete the picture: a briefcase (or shoulder bag or attaché case). Blue-collar workers are seen in uniforms with an open collar, large, functional pockets, and a tag with name or section on the breast pocket. Helmet, boots, work gloves, and safety belt com-

plete the ensemble. Women, who are lower in the corporate pecking order, must adhere to more standardization. OLs (“office ladies”) or secretarial staff typically wear a company uniform of white blouse, vest with name tag, skirt (usually 1.9 in, 5 cm, below the knees), and high heels.

At some companies, dress codes are enforced by military-like morning inspections. Besides company loyalty and dedication to work, adhering to dress codes indicates an individual’s aspiration to work toward a middle-class lifestyle as well as commitment to Japan’s collective project of economic nationalism.

See also **Mao Suit; Uniforms, Diplomatic; Uniforms, Military; Uniforms, Occupational; Uniforms, School; Uniforms, Sports.**

#### BIBLIOGRAPHY

- Davis, Fred. *Fashion, Culture, and Identity*. Chicago: University of Chicago Press, 1992.
- Lurie, Alison. *The Language of Clothes*. New York: Random House, 1981.
- McVeigh, Brian J. *Wearing Ideology: State, Schooling, and Self-Presentation in Japan*. Oxford: Berg, 2000.
- Rubinstein, Ruth P. *Dress Codes: Meanings and Messages in American Culture*. Boulder, Colo.: Westview Press, 1995.

Brian J. McVeigh

**DRESS FOR SUCCESS** “Dress for success” is the modern equivalent of “clothes maketh the man”—that is, it articulates the belief that what you wear matters in everyday life. However, in its modern guise, this is a discourse specifically on business dress that proclaims the importance of sartorial presentation in the workplace. Dress for success became popular during the mid-1970s and 1980s in the United States and Europe, but the principles that underpin it stem back much further. The idea that one can dress for success is closely aligned to the more general notion of “impression management,” the origins of which go back to the work of sociologist Erving Goffman and his dramaturgical metaphor (the idea that the social world functions like a stage and we, its social actors, are performers). Goffman’s work on “the presentation of self in everyday life” demonstrates how mundane features of body management are essential to the ongoing maintenance of a person’s identity: Specifically, how our body looks and behaves is often the basis of how others read and judge us (1971). While Goffman’s work was concerned with describing social order and interaction, his ideas were popularized outside sociology and have since achieved wide social application. Today “impression management” has become part of mainstream popular psychology and management and business studies, with dress for success a central plank of both. For evidence of the cultural significance of dress for success, one needs look no further than the huge market for books and services offering advice on how to dress ef-

fectively at work. Alongside popular “self-help” books, there is a huge industry in “image consultancy” offering all manner of “expert” advice on body presentation, from color analysis to wardrobe and shopping services. More recently, alongside such money-making ventures have sprung not-for-profit, dress-for-success shops offering services to the unemployed.

#### The Dress-for-Success Manual

The exposition of the “rules” of business dress are laid down in dress manuals, such as the now-classic John T. Molloy’s two manuals, *Dress for Success* (first published in the United States in 1975) and *Women: Dress for Success* (published in the United States in 1979). These manuals describe his formula for “successful” dressing. What Molloy calls his “wardrobe engineering” is a (pseudo) “science of clothing” based on quantitative “testing” of the different meanings individuals give to individual garments. What kind of dress did Molloy find was the most “effective” at conveying “one means business”? The dress found to “succeed” is conservative, tailored, and always “smart.” However, the way in which men and women should dress for the world of work differs. For men, this means black and gray suits, teamed with not-too-daring ties, and smart, polished shoes. However, while the traditional trousered suit works for men, it does not work for women. Indeed, by the very fact of his writing two manuals on work dress, Molloy points to the way in which dress at work is gendered, both reflecting and reproducing sexual difference. While both manuals have the same goal—the acquisition of status and power at work—men and women must attain it by different means, according to Molloy, and for a woman this means managing her sexuality. While an aspiring professional man need only worry about his dress (which suit to wear and in which color, which briefcase to carry, and so on), his female counterpart must also worry about her body, since her body is sexualized in a way that the male body is not.

The public world of work is a world that demands a clear separation from the erotic, and thus, women’s potentially sexual bodies must be covered appropriately. Women, Molloy argues, have to dress for “authority” since their social position, as women, puts them at some disadvantage compared with men at work. The wearing of tailored clothing, namely a smart jacket with tailored knee-high skirt is, according to Molloy, the most “effective” dress. It would seem, therefore, that while suggestive clothes must be avoided, women should aim to look “feminine” at all costs: the wearing of a skirt and the deployment of decorative items, a necktie, brooch, or other accessory, help to soften the severity of the suit. Indeed, Molloy warns career women against trying to “ape” men and claims that his 1980 manual was, in part, a response to those women who had been adopting the garb he had outlined in his first manual. His second stated reason is captured by his story of how, in the mid-1970s, when meeting three businesswomen in a bar, he was unable to

spot them. The businesswoman was literally not “visible” as such and was, according to Molloy, in need of a “uniform” that could be relied upon to connote the appropriate status.

The “uniform” that he subsequently helped inaugurate became known as the “power suit” and was a major phenomenon of the 1980s, defining a style of female professional dress that has now become something of a sartorial cliché: tailored skirt suit with shoulder pads, in gray, blue, or navy, accessorized with “token female garb such as bows and discreet jewelry” (Armstrong 1993: 278). These dress-for-success rules arose against the historical backdrop of the women’s movement into more prestigious forms of paid employment and addressed the increasing problem of how to rise on the career ladder and break the so-called “glass ceiling.” Note that in maintaining the suited torso, the tailored jacket and fitted skirt aimed to separate this female worker from her secretarial counterparts. Power dressing articulated the “career woman” and in doing so gave visible evidence of a new relationship of women to work that had once been the preserve of men (Entwistle 1997, 2001).

That fact that the “power suit” became a major fashion story for women in the 1980s is beside the point for “experts” such as Molloy. The aim of dress for success was to devise techniques that eliminate fashion from the daily process of dressing. The dress-for-success discourse is, in fact, an oblique and sometimes open critique of the fashion system. By virtue of its incessant momentum, fashion keeps the range of choices open, choices left to individuals who run the risk of making the “wrong” one. As individuals come to feel that more is at stake in how they look, especially at work, such a universe of choice is a problem. As a pseudoscience of clothing strategies, dress-for-success formulas, such as Molloy’s “wardrobe engineering,” offer clearly established guidelines to circumnavigate this precarious world of choice and provide a stable basis upon which to base decisions as to what to wear to work.

### Historical Precursors

As it is primarily a “self-help” manual, the modern dress manual sets out to mold and shape the self, calling upon readers to think about themselves and act upon themselves in particular ways. Molloy’s manual can therefore be examined as a “technology of the self,” to draw on Foucault’s concept (1988). “Technologies of the self permit individuals to effect . . . a certain number of operations on their own bodies and souls, thoughts, conduct and way of being so as to transform themselves” (Foucault 1988, p. 18). In this way, dress-for-success strategies encourage particular ways of thinking and acting upon the self, producing the individual as a “reflexive subject” (Giddens 1991); that is, a person who thinks about and calculates body and self, in this case, developing skills and techniques for dressing and presenting the self as a committed career-minded person. The idea that one’s dress conveys something of the “self” and that, specifi-

cally, one can dress for success at work may seem almost “common sense” today. However, these ideas have arisen out of particular historical circumstances and beliefs about the body and its relationship to personal identity. These are closely related to the emergence of particular forms of modern individualism.

One can trace the circumstances that gave rise to discourses on dress and appearance as far back as the eighteenth century, to the emphasis placed on the “self-made man” under conditions of industrial capitalism and the rise of Romanticism. The eighteenth and nineteenth centuries heralded an era of upward mobility: the new capitalist classes were achieving status and power through their own efforts, not through privileges of the old aristocracy. Individuals could, in other words, rise through the social hierarchy by virtue of their own efforts. This idea of the “enterprising” self reached its apotheosis with the ascendancy of neo-liberalism in the 1970s and 1980s under Reaganomics and Thatcherism; in other words, around the same time as dress-for-success ideas took hold. However, in the history of our modern self, another discourse at variance with capitalism is also important, namely Romanticism, and it underpins the idea of dress for success. Romantic poets, painters, and writers emphasized the idea of the “authentic” self and suggested that one’s outward appearance unproblematically reflects the inner self. While up until the eighteenth century public life had allowed a distance between outward appearance and inner self—a clear separation between public and private—under conditions of modern life, according to Richard Sennett (1977), one’s public appearance has to be a “true” reflection of the self. This Romantic notion of authenticity has become attached to the public sphere and is the dominant theme permeating discourse on the self at work, suggesting that how you look, from the first day of your job interview, signals your identity and commitment as a worker. Thus, in contemporary society, our bodies are bearers of status and distinction, as the sociologist Pierre Bourdieu (1984) has described in detail. This makes the body, its dress and manners, matters of great import in terms of the “envelope” of the self. As Joanne Finkelstein (1991) notes, increasingly over the nineteenth century appearance comes to stand as an important indicator of inner character and she suggests that the eighteenth-century socialite and “dandy” Beau Brummel exemplifies the wider social movement toward the self-styled or “fashioned” individual, concerned with promoting the self through the careful deployment of clothing. Finkelstein also analyzes the emergence of various “physiognomic” discourses over the nineteenth and twentieth centuries. Such discourses link outward appearance, from the shape of the face and overall body to dress, to inner “self.” She points to how, in America over the course of the nineteenth century, there was a movement toward individual self-promotion through dress: “for upwardly mobile young men how they looked was important not only as a means of business advancement,



but also as a measure of self-esteem” (Branner, in Finkelstein 1991, p. 114).

Important to the heightening self-consciousness of body and its outward appearance, and introducing the idea of dress for success, was the dress manual. It is important to note that such manuals are not, therefore, a recent phenomenon and can be seen as closely aligned with other kinds of “self-help” publications which have a longer history (Hilkey 1997). In the eighteenth and nineteenth centuries, as well as in the first half of the twentieth, one can find manuals on “how to dress like a lady” and how to put together a lady’s wardrobe on a modest budget. What is different about the manuals on dress that emerged in the 1970s and 1980s was the type of self they addressed and the kind of success sought. A number of commentators (Giddens 1991; Featherstone 1991; Lasch 1979; Sennett 1977) have argued that a new type of self has emerged in the twentieth century and an examination of the dress manual can be seen to indicate this. Featherstone calls this new self “the performing self” which “places greater emphasis upon appearance, display, and the management of impressions” (Featherstone 1991, p. 187) while Lasch (1979) calls it the “narcissistic self.” Featherstone (1991) argues that a comparison of self-help manuals of the nineteenth and twentieth centuries provides an insight into the development of this new self and conveys the movement from notions of “character” to “personality.” In the earlier self-help manual the self is discussed in terms of character values and virtues—thrift, temperance, self-discipline, and so on—and dress is discussed in terms of such things as thrift and “ladylike” decorum. In the twentieth century we find how “personality” in the self-help manual depends upon how one *appears* as opposed to what one is or should *become*; how, for example, to look and be “magnetic” and “charm” others. In this way, appearance comes to be something malleable, something transmutable. The increasing significance of appearance from the eighteenth century onward meant that people began to be concerned with the control of appearance and clothing. Contemporary Western societies testify to the intensification of these processes with more and more aspects of outward appearance “correctable” through diet, exercise, makeup, and plastic surgery, as well as dress, and with these appearances increasingly linked to identity. All these physiognomic discourses proclaim the notion that achieving the “right” outward appearance will result in greater personal happiness and, of course, success.

### Conclusion

It may well seem that the dress-for-success formulas of the 1980s have long since been replaced by more “individuality” and “creativity” in clothing. Indeed, the backlash to all these rules came in the 1990s with “dress down on Friday” introduced in offices both in the United States and United Kingdom. While we may like to think we are “individual” and while dress choice is welcomed by some,

the business and professional worlds remain conservative places, even today. Indeed, there has been a swing away from casual Fridays after some offices found that employees dressed far too casually to perform their duties effectively. Meeting a client in jeans or shorts is still taboo in most professions. Only in the “creative industries” are fashion and individuality openly welcomed, indeed, here one finds them essential. The body at work has to fit in with the overall business ethos of the office or sector. In young industries, like popular music, advertising and graphic design, for example, informality rules. However, older professions and industries still prefer the bodies at work to look suitable—that is, in a suit. The dress-for-success idea lives on and a lucrative industry of self-help advice and “experts” maintain the notion that what we wear to work really matters in our overall career “success.”

See also **Casual Business Dress; Fashion and Identity; Suit, Business.**

### BIBLIOGRAPHY

- Armstrong, L. “Working Girls.” *Vogue*, October 1993.
- Carnegie, Dale. *How to Win Friends and Influence People: How to Stop Worrying and Start Living*. London: Chancellor, 1994.
- Entwistle, Joanne. “Power Dressing and the Fashioning of the Career Woman.” In *Buy This Book: Studies in Advertising and Consumption*. Edited by M. Nava, I. MacRury, A. Blake, and B. Richards. London: Routledge, 1997.
- . “Fashioning of the Career Woman: Power Dressing as a Strategy of Consumption.” In *All the World and Her Husband: Women and Consumption in the Twentieth Century*. Edited by M. Talbot and M. Andrews. London: Cassell, 2001.
- Featherstone, Mike. “The Body in Consumer Society.” In *The Body: Social Process and Cultural Theory*. Edited by M. Featherstone, M. Hepworth and B. Turner. London: Sage, 1991.
- Finkelstein, Joanne. *The Fashioned Self*. Philadelphia: Temple University Press, 1991.
- Foucault, Michel. “Technologies of the Self.” In *Technologies of the Self: A Seminar with Michel Foucault*. Edited by L. Martin, H. Gutman and P. Hutton. Amherst: University of Massachusetts Press, 1988.
- Giddens, Anthony. *Modernity and Self-Identity: Self and Society in the Late Modern Age*. Stanford, Calif.: Stanford University Press, 1991.
- Goffman, Erving. *The Presentation of Self in Everyday Life*. London: The Penguin Press, 1971.
- Hilkey, J. *Character is Capital: Success Manuals and Manhood in Gilded Age America*. Chapel Hill: University of Carolina Press, 1997.
- Lasch, Christopher. *The Culture of Narcissism*. London: Abacus, 1979.
- Molloy, John T. *Dress for Success*. New York: Peter H. Wyden, 1975.
- . *Women: Dress for Success*. New York: Peter H. Wyden, 1980.
- Sennett, Richard. *The Fall of Public Man*. New York: W. W. Norton and Company, 1977.

Joanne Entwistle

**DRESS REFORM** Over the course of history the emergence of unorthodox clothing styles has revealed much about the social norms governing appearances. New ideologies concerning spirituality, health, hygiene, and gender have not only subverted existing social boundaries but also shaped the trajectory of fashion in the process. Quakerism, Bloomerism, aesthetic dress, and Jaeger dress may be examined as catalysts for both fashion and social change.

### Nonconformist Quaker Dress

During the years following the English Civil War of 1642, various influential clothing-reform movements flourished. One of the nonconformist groups that emerged during this time was the Religious Society of Friends, commonly known as Quakers. The group's founder, George Fox, established a set of social practices that were based on Christian ideologies and utopianism. The main thesis proposed by Fox was simplicity of appearance and lifestyle. His favor of spirituality over what he considered to be the unholy virtues of fashion signaled a radical move within the history of fashion.

The alternative clothing choices embraced by George Fox and his followers were set in direct opposition to the fashionable styles of the time. Quakers believed that the focus on aesthetics within the fashion industry was immoral. Instead Quakers wore modest, unstructured, and natural-colored garments that better reflected their Christian values of humility, piety, and simplicity. The strict adherence to their faith led Quakers to eschew contemporary fashions and any decorative clothing.

Both male and female apparel was constructed of functional, utilitarian fabrics such as calico and flannel. The simple color palette for both sexes consisted of gray, brown, cream, and pale green tones. Women commonly wore loose-fitting, long-sleeved dresses, aprons, and bonnets. Men wore unstructured coats, plain hats, trousers, and buckled shoes. For both sexes, functional garment details were also kept simple. Pockets were often placed internally, the use of buttons was restricted, and small accessories or jewelry was forbidden. The commonality of dress between the sexes not only created group uniformity but also visually reinforced their detachment from the wider society.

Quaker dress maintained popularity within marginal groups until the 1920s. The Quaker adherence to plain dress styles was a nonverbal protest against the aesthetic focus of fashion. "Plain clothing" was adopted by other religious groups as well, such as some sects of German Pictists. Although the movement only achieved minority status, it nevertheless succeeded in challenging the ornamental nature of eighteenth-century dress.

### Dr. Gustav Jaeger

Another revolutionary movement within the history of fashion involved the promotion of a healthy and rational approach to dress. During the eighteenth century, vari-

ous medical professionals gradually began to question the irrational and unhealthy nature of the existing fashionable garments. Many argued that corsets and heavily layered undergarments restricted movement, crippled the spine, and harmed internal organs. As a consequence, certain medical professionals began to encourage men and women to turn their attention away from aesthetics and toward their health.

During the 1880s, Dr. Gustav Jaeger, a German Professor of Physiology and Zoology at the University of Stuttgart, promoted what he believed to be a healthy alternative to conventional dress. In 1884 Dr. Jaeger developed a unique system of dress based on the belief that wearing undyed sheep wool against the skin would enable skin to breathe freely and prevent perspiration. Dr. Jaeger recommended avoiding clothing made of silk, cotton, or linen—or any cloth which had been dyed. He was also highly critical of the corset.

The nonconformist apparel Dr. Jaeger introduced was designed to follow the contours of the body closely, so as to prevent exposure to drafts that he believed dangerous to the health. Jaeger was best known for undyed woolen undergarments for both sexes, including chemises, petticoats, and breeches. The range was later expanded to include other items of clothing such as jackets and trousers, as well as bedsheets.

The protective properties of woolen undergarments were widely promoted. Dr. Jaeger was an exhibitor at the *International Health Exhibition* of London in 1884. He also published widely and released a book in 1887 titled *Essays on Health Culture*. Although the Jaeger mode of dress was targeted to all, it initially only acquired a minority and predominately middle-class following.

As the system gained gradual acceptance however, London retailer Lewis Tomalin purchased the name and opened a store on London's Regent St. As public interest in health and comfort progressed, Lewis Tomalin gained popularity among male and female consumers alike. Competitive retailers gradually became aware of the changing social consciousness and began producing varied ranges that expanded upon Jaeger's original ideologies.

By the 1920s, however, the popularity of Dr. Jaeger's undergarment designs gradually began to wane as fashions became increasingly fitted. Nevertheless, the adoption and persistence of his health-reform movement illustrates that a portion of society was prepared to choose clothing primarily on the grounds of supposed health benefits rather than fashionability.

### Bloomerism

In the nineteenth century, as male clothing became increasingly utilitarian, certain women began to feel constrained by the fashionable clothing styles available to them. The most famous dress-reform movement was called Bloomerism. The movement was named after New York resident, Amelia Jenks Bloomer. In 1851 Bloomer

published an article in the feminist publication she edited called *The Lily*, stressing the importance of introducing reformed garments for women. The article was later reprinted in popular American press and gained a widespread readership. Later that year, along with her friends Elizabeth Smith Miller and Elizabeth Cady Stanton, she was seen in public dressed in a shortened skirt with Turkish trousers. Although Amelia was not the first woman to wear or invent the garment, the name evolved as a consequence of her association with *The Lily*.

The bloomer costume consisted of loosely fitting, Turkish-style trousers that gathered and frilled at the ankle with an elasticized cuff. The trousers were worn beneath a shortened skirt that fell below the knee, and a fitted bodice. In contrast to the prevailing fashions, the outfit was claimed to be comfortable, convenient, safe, and healthy. Bloomer dress focused not on the way one looked, but rather on the way one felt. The original intention of the garment was thus not to challenge established gender boundaries, but rather to increase mobility and function.

A majority of Victorian society was highly critical of the innovative style of dress. Since trousers were considered to be a traditional symbol of masculinity, female devotees of Bloomerism were subject to ridicule and abuse. For example, satirical caricatures of Bloomers appeared in magazines such as *Punch*. As a consequence, most abandoned the costume after only a few months.

Amelia Bloomer had herself discarded the costume by the mid-1850s. Although the movement was short lived, it exposed entrenched gender stereotypes and challenged the dominant ideals of femininity. As a consequence the innovative costume signaled an advance in the direction of female emancipation.

### Rational Dress

The bloomer costume was revived through the establishment of the Rational Dress Society in London during the 1880s. The Society was chaired by Viscountess Haberton and sought to advocate the development of a rational system of clothing. During the late 1880s, the Society started publishing the *Rational Dress Society Gazette* that campaigned against restrictive fashions.

One of the main premises of the Society was the belief that women should forsake heavy undergarments and corsets, as such items restricted movement. In later years members adopted short jackets with bifurcated knee-length skirts, as it was believed such garments enhanced physical mobility. The introduction of new sports such as bicycling and lawn tennis greatly assisted the growing tendency toward functional clothing. In these arenas bifurcated garments became an acceptable mode of sports dress.

### Aesthetic Dress

During the same period, the Aesthetic Movement began to emerge out of the field of decorative arts. Aesthetic

devotees encouraged women to discard the restrictive garments in vogue and adopt loose-fitting, "artistic" apparel instead.

The style of dress was inspired by the work of Pre-Raphaelite painters such as Rossetti and consisted of loosely draped, medieval-styled robes. The style appealed to a significant number of middle-class women. Oscar Wilde was an avid supporter of the movement. In London, the Liberty Company produced aesthetic dresses.

In the early twentieth century, reform styles influenced the fashions created by avant-garde designers such as Paul Poiret and Mariano Fortuny.

See also **Aesthetic Dress; Bloomer Costume; Corset; Gender and Dress; Liberty & Co; Politics and Fashion; Religion and Dress.**

### BIBLIOGRAPHY

- Breward, Christopher. *Fashion*. Oxford: Oxford University Press, 2003.
- Crane, Diana. *Fashion and its Social Agendas: Gender, Class and Identity in Clothing*. Chicago and London: University of Chicago Press, 2000.
- Etten, Henry Van. *George Fox and the Quakers*. London: Longmans, 1959.
- Fischer, Gayle V. *Pantaloon and Power: A Nineteenth-Century Dress Reform in the United States*. Kent, Ohio, and London: Kent State University Press, 2001.
- Gathey, Charles Neilson. *The Bloomer Girls*. London: Femina Books, 1967.
- Newton, Stella Mary. *Health, Art and Reason: Dress Reformers of the 19th Century*. London: John Murray, 1974.

*Kristina Stankovski*

**DRESS SHIRT** Interestingly, the term dress shirt has a different meaning on both sides of the Atlantic. In the United Kingdom, a dress shirt is known as a formal shirt. In the United States, the dress shirt makes up part of the standard ensemble required for evening dress for formal occasions. A man will be required to wear a dress shirt, which essentially must be white with double French cuffs and cuff links, with his tuxedo, cummerbund, and butterfly or bat-wing black tie.

### History

Shirts appeared first in European dress in the seventeenth century as a kind of underwear, designed to protect expensive waistcoats and frock coats from sweat and soil. By the early nineteenth century, shirts had assumed importance as garments in their own right. The emphasis placed by Beau Brummell and other dandies on wearing clean, perfectly styled linen brought the shirt into increased prominence as an essential male garment.

Even up to the turn of the twentieth century, the white shirt was considered to be the symbol of a gentleman. But



in order for shirts to look clean, particularly the collar, a man would have to have enough money for them to be washed frequently. According to popular legend, Mrs. Orlando Montague of New York City realized the collars on her husbands' shirts needed washing much more than the main body and set about removing all the collars and sewing on strings to reattach them once they had been washed. The trend soon caught on, even though many men struggled to piece their shirts back together again.

Detachable versions of both the turndown and wing collar were available with the added advantage of being able to alter the collar depending on circumstance. Victorian men were also known to buy celluloid or paper collars to save money. However, due to the laborious process of refitting the collars on the shirts, the development of the domestic washing machine, and developments in fabric technology, the detachable collar has all but disappeared from the male wardrobe.

### The Twentieth Century

Shirts made to be worn with formal attire were traditionally cut with a stiff wing collar in the late nineteenth century, and that style remained standard into the period after World War I. The Duke of Windsor developed the move to a pleated front formal shirt with a turned-down collar in the 1920s. The Duke explained to his shirt maker that he wanted a softer alternative to the stiff-winged collar shirt. The pleated front of the dress shirt is designed not to extend below the waist, so that the front will not bulge forward when the wearer sits down.

The wing collar remains the more formal of the two styles and usually comes in reinforced pique and sometimes with a fly front to conceal the buttons. The wing-collared shirt remains the more flattering to those with long necks and the preferred choice for their partners by women.

By the late 1960s there was a trend in evening shirts toward more ornate styles. Almost-feminine dress shirts, with huge ruffles, horizontal pleats, embroidery, and lace all featured, were finished off with mandarin collars and a variety of new colors. This trend carried on until the 1970s, but such ostentation is considered a sartorial blunder in the early 2000s, and most men have reverted to the more traditional styles in white fabrics.

An interesting trend that developed during the 1980s was the adoption of the dress shirt by women, who wore it both formally to black tie events and as an item of casual wear. This trend has all but vanished. (The formal dress shirt had hitherto been an entirely masculine item of dress, though in the 1890s some women who adopted the tailored styles of the New Woman also wore blouses that somewhat resembled men's formal shirts.)

### The American Dress Shirt

A dress shirt in the United States is considered to be any shirt with a collar (attachable or detachable) that is

worn with a jacket and a tie. This includes both the wing-collared and turned-down collared shirts worn by men as evening wear, but these are referred to as formal shirts.

Styles of American dress shirts include pinned, button-down, Barrymore, plain, or tab-collared shirts.

See also **Shirt; Sport Shirt.**

### BIBLIOGRAPHY

- Amies, Hardy. *A, B, C of Men's Fashion*. London: Cahill and Company Ltd., 1964.
- Barnes, Richard. *Muds!*. London: Plexus Publishing Ltd., 1979.
- Byrde, Penelope. *The Male Image: Men's Fashion in England 1300–1970*. London: B. T. Batsford, Ltd., 1979.
- Chenoune, Farid. *A History of Men's Fashion*. Paris: Flammarion, 1993.
- De Marley, Diana. *Fashion for Men: An Illustrated History*. London: B. T. Batsford, Ltd., 1985.
- Keers, Paul. *A Gentleman's Wardrobe*. London: Weidenfeld and Nicolson, 1987.
- Roetzel, Bernhard. *Gentleman: A Timeless Fashion*. Cologne, Germany: Konemann, 1999.
- Schoeffler, O. E., and William Gale. *Esquire's Encyclopedia of 20th Century Fashions*. New York: McGraw-Hill, 1973.

Tom Greatrex

**DRY CLEANING** Dry cleaning is the cleansing of a textile utilizing an organic solvent as opposed to water. The development of dry cleaning is predicated on the fact that as a solvent, water is ineffective in the removal of non-water soluble soils. These soils are primarily oil-based stains such as paint, grease, wax, tar, and body oils.

Early attempts at "dry cleaning" were uncovered within the ruins of Pompeii. Evidence suggests that clothing tradesmen used fuller's earth to absorb soils and grease from garments. Until the end of the seventeenth century, absorption by the means of fuller's earth, or (in later centuries) paper and a hot iron, were the only methods available for the removal of oily stains.

The first use of an organic solvent as a spot-removing agent occurred in Western Europe during the 1680s. Oil of turpentine is a by-product derived from the distillation of turpentine (pine pitch). Used in medicines and for the making of varnish, oil of turpentine was discovered to also be an effective solvent for removing grease stains from fabric. Fabric processors known as dyers and scourers began utilizing this new solvent to supplement the washing process.

By the early nineteenth century, two solvents—camphene (a mixture of oil of turpentine and naphtha) and benzine, a petroleum distillate—had replaced oil of turpentine for use in clothing care. Camphene, primarily sold as illuminating oil, was employed in an immersion

bath process for cleansing satin goods, silk dresses, fancy waistcoats, and lace. Another major benefit derived from cleaning natural fibers in dry solvents had been realized.

Dry solvents are liquids that do not wet or swell textile fibers. The cleaning mechanisms of dry solvents are thus different from water, in which wetting and swelling play a significant role. In natural fibers (silk, wool, cotton, and linen), this swelling can lead to shrinkage, distortion, finish loss, or dye bleeding. Cleaning with dry solvents is a gentler process that requires less finishing, thus prolonging the life and feel of the textile.

There were two problems associated with the use of these early solvents. The solvents were extremely flammable, having flashpoints around 70° F. (21° C.), and a strong odor remained in the clothes without proper drying.

Commercial dry cleaning was first practiced in the Jolly Belin Dye Works in Paris in 1825. William Spindler of Berlin visited the Jolly Works in 1854 and brought the process to Germany. James Pullar, Spindler's son-in-law, introduced commercial cleaning to Scotland.

At the beginning of the twentieth century, mechanized improvements such as rotating cleaning drums, hydro extractors, solvent purification systems, and the first dry solvent soap increased both the safety and effectiveness of the dry-cleaning process. The solvent of choice was gasoline.

Modern dry cleaning was ushered in with the development of two new solvents. In 1926 came Stoddard solvent, a petroleum-based hydrocarbon with a flashpoint of 100° F. (38° C.), and in 1932, nonflammable perchloroethylene, or perc, was introduced. Equipment advances derived from the electric motor and pneumatics allowed for controlled rotation of the cleaning drum and high-speed solvent extraction. The steam boiler enabled controlled drying, utilizing moist heat as well as providing steam for the finishing irons and presses.

In the late 1980s, perchloroethylene was designated a possible carcinogen, and stricter controls monitoring usage were imposed. This led to the development of several alternative solvents: the silicone-based Green Earth process, liquid carbon dioxide, and synthetic hydrocarbons with flashpoints exceeding 145° F. (63° C.). These solvents are considerably less aggressive, meaning they have less degreasing power than perchloroethylene. The benefit is that they can safely clean any material from feathers to a heavily beaded gown. With proper application, the equipment and solvent options available in the early 2000s can effectively clean any fabric or design element used in the realization of haute couture fashions.

See also **Laundry**.

#### BIBLIOGRAPHY

Cambridge, E. M. "Benzene and Turpentine: The Pre-History of Dry-cleaning." *Ambix* 38 (2) (July 1991).

International Fabricare Institute. *Dry Cleaning Fundamentals*. Silver Spring, Md.: IFI, 2003.

Textile Conservation Center. "Dry-cleaning I: Solvents." *Technical Bibliographies*. North Andover, Mass.: Museum of American Textile History.

*John Lappe*

**DUFFLE COAT** Duffle is a coarse, heavy woolen fabric with a thick nap, traditionally worn by fishermen. Its name derives from the town in Belgium where it was originally manufactured beginning in the seventeenth century. The fabric is most commonly associated with a box-cut, loose-fitting, three-quarter-length coat with patch pockets and a square shoulder yoke, fastened with wooden or buffalo horn toggles and hemp loops. Sharing the name of its fabric, the duffle coat is the only classic overcoat to have a hood.

#### History

Although hoods of a similar shape to that of the modern duffle coat were indeed used as far back as the Bronze Age (some think a monk's habit was the forerunner of the duffle coat), the actual design of the duffle coat originated in Poland (known as the Polish-coat) in the first half of the nineteenth century. John Partridge, a British purveyor of outdoor clothing, began to design and sell the duffle in 1890.

The duffle actually came into its own when the Royal Navy adopted it early in the twentieth century. Sailors wore the coat, sometimes with a pair of matching drawstring trousers, as protection from the elements when assigned to deck watch. It was further popularized by Army Field-Marshal Bernard Montgomery during World War II, and indeed the beige desert version he sported at that time became known, in Europe at least, as the "Monty." Huge quantities of army surplus duffles flooded the market after the war ended and it soon became a warm winter favorite with British and American consumers alike. Mothers would dress their young children in them due to their warmth, but duffle coats also achieved cult status among college students and intellectuals, worn with an former naval sweater, college scarf, and corduroy trousers.

#### The Duffle in the Twenty-first Century

Little has changed with the duffle since its Polish origins. The classic version is generally tartan lined and has a hood and an extra layer of cloth around the shoulders for added protection against the elements. Genuine horn toggles and hemp-fiber loops add an element of authenticity.

Modern fabrication, fastenings, and styling have led to a new generation of duffle coats featuring zippers, reflective safety tape, Gore-Tex linings, and printed designs on the outer fabric.

The British designer Alexander McQueen produced a version of the duffle coat for his autumn 2002 collec-

tion. Jean-Charles de Castelbajac showed a duffle coat in 1990, cut in wool with leather trim. More interestingly, the Savile Row tailor Richard Anderson is the first tailor on the Row to create a bespoke option. Instead of the original classic beige and deep blue hues, consumers have a wide variety of colors to choose from, such as dark brown, yellow, red, racing green, and burgundy.

With fans spanning a spectrum from the actress Gwyneth Paltrow, to the rock band Oasis, the duffle continues to maintain a following that transcends class, wealth, or creed.

See also **Coat; Outerwear.**

#### BIBLIOGRAPHY

- Amies, Hardy. *A, B, C of Men's Fashion*. London: Cahill and Company Ltd., 1964.
- Byrde, Penelope, *The Male Image: Men's Fashion in England 1300–1970*. London: B. T. Batsford, Ltd., 1979.
- Chenoune, Farid. *A History of Men's Fashion*. Paris: Flammarion, 1993.
- De Marley, Diana. *Fashion for Men: An Illustrated History*. London: B. T. Batsford, Ltd., 1985.
- Schoeffler, O. E., and William Gale. *Esquire's Encyclopedia of 20th Century Fashions*. New York: McGraw-Hill, 1973.

Tom Greatrex

**DYEING** A general term that describes many complex processes in which color is added in the form of a solution of synthetic or natural dyes to fibers, yarns, or fabrics. Dyes are organic chemicals that produce intense color, are water soluble or dispersible, and bond with fibers. When struck by energy in the form of light, the chemical absorbs, reflects, or transmits specific wavelengths of the energy. The wavelengths and concentrations of the reflected light determine the color seen. The composition and structure of the dye chemical determines its color and the fiber with which it forms a chemical attraction. This means that dyes are fiber specific. Dyes are incorporated into fibers by chemical reactions, absorption, or dispersion. Commercially important dyes must be relatively fast to resist environmental factors such as cleaning agents, light, air pollutants, and perspiration.

Dyeing is usually done by immersing and moving the textile in a heated, dilute dye solution in a bath or vat. Except for a few cases (for example, resist methods), the desired result is an even or level color. Dyeing includes some preparation steps, such as scouring, bleaching, and mordanting, as well as some after-treatment steps to improve the fastness of certain dyes. Dyeing can be classified based on the stage of processing of the textile when the dye is added, the process used in dyeing, or the type of dye used.

#### Dyeing Stage

In mass pigmentation, dope dyeing, or solution dyeing, colorant is added to manufactured and synthetic fibers

before fiber formation. Mass pigmentation is permanent and relatively expensive. Fiber or stock dyeing adds dye to loose fibers, fiber top, or sliver (a yarn precursor in producing yarn from staple fiber). Stock dyeing creates heather effects in which adjacent fibers are different colors. In yarn and skein dyeing, yarns are dyed for fabrics, such as denim and chambray, in which only the warp yarns are dyed. Yarn dyeing produces better quality stripes, plaids, and structural designs with colored woven or knit designs. Piece dyeing is used to dye fabric lengths or yardages a solid uniform color. However, fiber blends, mixtures, and combinations present other options for piece dyeing. In cross dyeing, each fiber type absorbs a different color dye. Cross dyeing is one way of achieving a yarn-dyed appearance while skipping the yarn-dyeing step. In union dyeing, dyes from different classes are carefully selected to create a solid color on a fabric of two or more different fiber types. In product or garment dyeing, the textile is cut and sewn into the final product and then dyed. Careful preparation and selection of thread, closures, labels, and trims is necessary to ensure that all desired components are dyed the same color while other components (labels, for example) are not dyed or stained.

#### Dyeing Process

Many different dyeing processes exist. In batch processes, a predetermined quantity of fiber or length of yarn or fabric is dyed. In continuous methods, very long lengths of yarn or fabric are dyed. In skein dyeing, yarns are wrapped around poles and vat dyed. In package dyeing, yarn is wound onto perforated tubes through which dye is pumped. In beam dyeing, yarn or fabric is wrapped around a large perforated beam through which dye is pumped. In beck and jet dyeing, fabric is loosely twisted into a long loop and circulated around reels and guide rollers into and out of the dyebath. Jig dyeing is a batch process in which the fabric is under tension during dyeing as it passes through the dyebath and winds onto one roller, reverses direction, and passes back through the dyebath and onto the other roller. In continuous dyeing, the dye is padded onto the fabric, excess dye is removed by rollers, and steam heat sets the dye.

#### Dye Class

Dye classes can be organized by application method. Acid dyes require an acidic pH, are used on wool, silk, and some manufactured fibers, and produce strong clear colors. Metalized or mordant dyes incorporate metal in their molecular structure that dulls color but improves wash fastness. Direct dyes are applied directly to cellulose fibers in a neutral or alkaline bath and give slightly dull shades. They exhibit poor wash fastness, unless after-treated with a metal salt solution. Disperse dyes are slightly water soluble and used to dye most synthetic fibers. Fiber reactive or reactive dyes are applied in an alkaline environment, react with the hydroxyl groups of cellulose, and produce bright shades on cellulose. Sulfur





**Dyers working in a tannery.** Though most dyeing today is done with the help of machinery, the centuries-old process of hand dyeing has not completely disappeared. © JOHN R. JONES; PAPILO/CORBIS. REPRODUCED BY PERMISSION.

and vat dyes are solubility cycle dyes that are applied to cellulosic fibers in a reduced, colorless form and reoxidized to the insoluble, colored form on the fiber. They have good fastness to washing and sunlight. Basic or cationic dyes are applied to cellulosic, protein, and some synthetic fibers in slightly acidic or neutral solutions. Azoic dyes are formed on the fiber through a coupling reaction of two components. Natural dyes are complex mixtures of components derived from plants, animals, or minerals.

### History of Dyeing

Dyeing was a hand process for thousands of years. Dyers used large containers or vats for coloring relatively short lengths of fabric or small quantities of fiber and yarn. Until the development of synthetic dyes, all dyes were natural compounds. Fastness varied widely among the natural dyes. The processes required to achieve certain colors were long and involved and carefully guarded by dyers. In the latter half of the nineteenth century, research into a better understanding of the chemistry of natural dyes led to the development of synthetic dyes. By approximately 1900, synthetic dyes had replaced natural dyes in almost all applications.

Developments during the industrial revolution increased the amount of fiber, yarn, or fabric dyed in a vat. Dye boxes, vats, and jigs were the primary pieces of equipment used to dye industrial quantities of fabric in batch methods. However, in the twentieth century, researchers developed continuous methods so that undyed fabric would enter and dyed fabric would exit the machine. Other twentieth-century developments increased production rates, improved dye quality, and lowered costs.

See also **Dyeing, Resist; Dyes, Chemical and Synthetic; Dyes, Natural.**

### BIBLIOGRAPHY

- Kulkarni, S. V., C. D. Blackwell, A. L. Blackard, C. W. Stackhouse, and M. W. Alexander. *Textile Dyeing Operations: Chemistry, Equipment, Procedures, and Environmental Aspects*. Par Ridge, N.J.: Noyes Publications, 1986.
- Society of Dyers and Colourists and the American Association of Textile Chemists and Colorists. *Colour Index*. 3rd ed. London: Author, 1971.
- Tortora, Phyllis G., and Robert S. Merkel. *Fairchild's Dictionary of Textiles*. 7th ed. New York: Fairchild Publications, 1996.
- Trotman, E. R. *Dyeing and Chemical Technology of Textile Fibres*, 6th ed. New York: John Wiley and Sons, 1984.

Sara J. Kadolph

**DYEING, RESIST** Resist printing is a method used to apply a design on a fabric. It requires the covering of parts of the fabric in a way that will keep the dye from penetrating the open areas. The cover may be a variety of materials. Other than flat bed silk-screening and rotary silk-screening, resist-printing processes are hand methods. Wax is used in batik, while string or rubber bands are used in the tie-dye process. Similar to tie-dye is the ikat process, where the warp yarns are tied before dyeing. Another similar process to tie-dye is Shibori, where the fabric is given a three-dimensional form and folded, stitched, plaited, or twisted.

Also similar to tie-dye is the process called tritik. To prepare the fabric for dyeing, the fabric is stitched by hand or machine in the planned design. The thread is then pulled to draw the fabric. Where the fabric is close together it resists the dye.

Stencil printing is another form of resist printing. To make the stencil, designs are cut out of wood, paper, waxed paper, thin metal, or cardboard to cover the parts that will not be dyed. The open design areas need to be fastened to the adjacent areas; the attachments are usually noticeable in the print. A separate stencil is made for each color. The stencil is placed over the fabric. A color paste is applied to the open areas or the dye may be applied by an airbrush or spray gun. The stencil is removed and the next stencil is placed on the fabric.

Silk-screen printing is a process to apply designs either by hand or by automatic methods. The screen is coated with a material that is then removed in the design areas. Screens at one time were made from silk but in the early 2000s screens are either made from synthetic fibers or a metal mesh. A screen will be prepared for each color in the design. The screens are placed individually on top of the fabric by hand and the dye paste is forced onto the fabric through the open (design) areas of the screen by a squeegee. The screen is removed and moved to the next position on the fabric.

Flat bed silk-screening and rotary silk-screen printing are automatic methods. Flat silk-screening is similar to hand silk-screening but the fabric moves on a conveyor belt at regular intervals. The screens are placed above and are lowered automatically. Flat silk-screen printing is economically feasible for small runs and large designs.

Rotary silk-screen printing is a much faster system and used more often. Instead of flat screens, the screens are cylindrical and the dye paste is inside the roller. The squeegee forces the dye paste out of the roller on the fabric as it rotates. The design repeat is only as large as the circumference of the roller. Colorfastness of resist prints will be dependent on the dyestuff, the fiber, the pre-treatment and absorbency of the fabric used, and the method of application.

*See also* **Batik; Ikat; Tie-Dyeing.**

#### BIBLIOGRAPHY

- Bosence, Susan. *Hand Block Printing and Resist Dyeing*. London: David and Charles, 1985.
- Wells, Kate. *Fabric Dyeing and Printing*. Loveland, Colo.: Interweave Press, 1997.

*Robyne Williams*

**DYES, CHEMICAL AND SYNTHETIC** Synthetic dyes are manufactured from organic molecules. Before synthetic dyes were discovered in 1856, dyestuffs were manufactured from natural products such as flowers, roots, vegetables, insects, minerals, wood, and mollusks. Batches of natural dye were never exactly alike in hue and intensity, whereas synthetic dyestuffs can be manufactured consistently. The use of computers and computer color matching (CCM) produces color that is identical from batch to batch.

William Henry Perkin, an eighteen-year-old English chemist, was searching for a cure for malaria, a synthetic quinine, and accidentally discovered the first synthetic dye. He found that the oxidation of aniline could color silk. From a coal tar derivative he made a reddish purple dye. The brilliant purple was called mauve. The dye was not stable to sunlight or water and faded easily to the color presently named mauve, a pale purple. This discovery resulted in additional research with coal tar derivatives and other organic compounds and an entire new industry of synthetic dyes was born. In the twenty-first century, synthetic dyes are less expensive, have better colorfastness, and completely dominate the industry as compared with natural dyes. Thousands of distinctly different synthetic dyes are manufactured in the world.

Dyes are classified by their chemical composition, the types of fibers to which they can be applied, by hue, or by the method of application. Dye molecules may attach to the surface of the fiber, be absorbed by the fiber, or interact with the fiber's molecules. Each fiber reacts differently to dyes. Fiber modifications will also react differently to the same dye. Within a dye classification, different hues will have different colorfastness.

The Society of Dyers and Colourists (SDC) and the American Association of Textile Chemists and Colorists (AATCC) classify dyes by their chemical composition. In the publication, *The Colour Index International*, dyes are listed by their generic name, which indicates the application class, and by a *Colour Index constitution number* (CI number) which indicates the chemical structure.

#### Classes of Dyes

Acid (anionic) dyes are water-soluble dyes applied to wool, silk, nylon, modified rayon, certain modified acrylic, and polyester fibers. Fibers that will be damaged by acids, such as cellulose, cannot be dyed with this family of dyes. The dyes in this class vary in their chemical composition but all use an acid bath. These dyes produce

bright colors and have a complete color range but colorfastness varies.

Azoic (naphthol) dyes are produced within the fiber of cellulose fibers. The fiber is impregnated with one component of the dye, followed by treatment with another component, thus forming the dye. When the two components are joined under suitable conditions (a low temperature water bath is employed) a large, insoluble, colored molecule forms within the fiber. Because the color is within the fiber, colorfastness is excellent. Excess color on the outside of the fiber will rub off (crock) if not removed.

Basic (cationic) dyes are very bright but have poor colorfastness; they have limited use on cellulosic and protein fibers. Wool and silk can be dyed by basic dyes in a dye bath containing acid. Cotton fibers can be dyed by basic dyes but only in the presence of a mordant, generally a metallic salt. The colored portion of the dye molecule carries a positive charge. Basic dyes are relatively colorfast on acrylic fibers. Nylon and polyester fibers that have been modified to accept basic dyes will exhibit excellent colorfastness. The first synthetic dye, mauveine, belongs in this class.

Direct (substantive) dyes are soluble and have an affinity for cellulose fibers. An electrolyte, salt, is added to the dye bath to control the absorption rate of the dye by the fiber. The dye is absorbed by the fiber; colorfastness to light is good but colorfastness to laundering is not. Direct dyes are best used when wet cleaning is restricted. Developed direct dyes are those that are developed on the fabric after dyeing. They produce an insoluble dye that forms a chemical bond with the fiber molecules. Developed direct dyes have better wash fastness but poorer light fastness as compared with direct dyes. Both are used on lower-cost fabrics.

Disperse dyes were first developed to dye acetate fibers. Hydrophobic fibers have little affinity for water-soluble dyes. A method to dye hydrophobic fibers by dispersing colored organic substances in water with a surfactant was developed. The finely colored particles are applied in aqueous dispersion and the color dissolves in the hydrophobic fiber. Disperse dyes are the best method for dyeing acetate and polyester. Acrylic, aramid, modacrylic, nylon, olefin, and polyester are dyed by dispersed dyes; colorfastness is good to excellent.

Pigment dyes are not dyes but insoluble coloring particles. Pigments are added to the spinning solution (the liquid fiber before extrusion) of synthetic fibers and become an integral part of the fiber. Colorfastness is excellent. Pigments are also printed on fabric using resin binders. The adhesive attaches the color to the fabric. Colorfastness is dependent on the binder or adhesive used rather than the pigment. Pigment printing is an economical and simple means of adding color to fabrics.

Reactive (fiber-reactive) dyes combine with fiber molecules either by addition or substitution. The color cannot be removed if properly applied. Colors are bright

with very good colorfastness but are susceptible to damage by chlorine bleaches. Reactive dyes color cellulose (cotton, flax, and viscose rayon), silk, wool, and nylon. Reactive dyes are used in conjunction with disperse dyes to dye polyester and cellulosic fiber blends. They were introduced to the industry in 1956.

Sulfur dyes are insoluble but become soluble in sodium polysulphide. They have excellent colorfastness to water. Another advantage is their low cost and ease of application. Dark shades—black, brown, navy blue—are typical of sulfur dyes. Newer sulfur dyes are available in brighter colors. They perform well if correctly applied. They are susceptible to damage by chlorine bleaches. Sulfur dyes color primarily cellulose, such as heavyweight cotton and viscose rayon.

Vat dyes are insoluble in water but become soluble when reduced in the presence of an alkali. Oxidizing the dyed fabric produces a water insoluble dye. The term vat dyes is derived from the large vessels used to apply the dye. The first synthetic indigo dye, introduced to the industry in 1896, belongs to this class. Vat dyes have an incomplete color range but good to excellent colorfastness. They are primarily used to dye cotton work clothes, sportswear, prints, drapery fabrics, and cotton polyester blends. (1068)

See also **Dyeing; Dyes, Natural.**

#### BIBLIOGRAPHY

- Aspland, J. R. *Textile Dyeing and Coloration*. Research Triangle Park, N.C.: American Association of Textile Chemists and Colorists, 1997.
- Perkins, Warren S. *Textile Coloration and Finishing*. Durham, N.C.: Carolina Academic Press, 1996.
- Society of Dyers and Colourists, and the American Association of Textile Chemists and Colorist. *The Colour Index International*. 9 vols. 3rd ed. West Yorkshire, England: Bradford, 1971–1992. Fourth edition (2004) available online through subscription <www.colour-index.org>.

*Robyne Williams*

**DYES, NATURAL** Natural dyes are obtained from natural sources. Most are of plant origin and extracted from roots, wood, bark, berries, lichens, leaves, flowers, nuts, and seeds. Others come from insects, shellfish, and mineral compounds. Natural dyes were the only source of color for textiles, leather, basketry, and other materials until synthetic dyes were developed in the latter half of the nineteenth century. Of the thousands of natural color substances, very few became significant commercially. Dyestuff refers to the plant or other material from which the dye is extracted. Complete palettes are achieved by dyeing in one bath and sequential dyeing in two or more baths.

There are two types of natural dyes. Adjective or additive dyes such as madder must use a mordant (a chem-



ical that fixes a dye) to bond with fibers. These are the most common type and have been used for at least 2,000 years. Substantive dyes bond with a fiber without the use of a mordant or they contain tannin, a natural mordant. Examples of substantive dyes include safflower, cochineal, and black walnut. Mordants are chemical compounds that combine with the fiber and the dye forming a chemical bridge between the two. Madder, cochineal, and other commercially important natural dyes are polychromic, meaning that they yield different colors with different mordants. Common mordants are weak organic acids, such as acetic or tannic acid, and metal salts including aluminum ammonium or potassium sulfate, ferrous sulfate, and copper sulfate. Usually, the textile to be dyed is simmered in a mordant solution before dyeing (pre-mordanting). Other options include adding the mordant to the dyebath or treating with another mordant after dyeing to shift the color.

### Current Use

Natural dyes are used in small quantities by artists and craftspeople. Some commercial use of natural dyes is a response to concerns about synthetic dyes and environmental pollution. Natural dyes are a renewable resource and contribute to rural economic development. However, in most commercial applications, natural dyes do not compete with synthetic dyes that are available in more colors, more uniform in composition facilitating color matching, and of known ratings to fading agents. Contrary to common assumptions, some natural dyes have excellent fastness to light, cleaning agents, water, and perspiration. Commercially available natural dye extracts facilitate color matching and make the dyeing process less involved.

### Historic Natural Dyes

Evidence of well-developed dye works exists in many parts of the world. Ancient Egyptians, Phoenicians, and Peruvians were known for their excellent dyeing. Italian dyers were among the best from Roman times through the sixteenth century. Dyers from India were supreme in dyeing cotton. Dyers in China specialized in dyeing silk. Natural dyes were major trade items throughout history until the development of synthetic dyes. By the early years of the twentieth century, natural dyes had been replaced in most applications. However, most of these dyes remain important for artists, craftspeople, and niche producers.

Yellow dyes are the most numerous natural dyes, but most are weakly colored with poor lightfastness. The most important yellow dye in Europe was weld (*Reseda luteola*), which had better lightfastness than the dyes imported from Asia: saffron (*Crocus sativus*), safflower (*Carthamus tinctorius*), and quercitron (*Quercus tinctoria nigra*). Osage orange (*Machura pomifera*) is a contemporary dye extracted from wood and sawdust from a native North American tree.

Red dyes included madder, cochineal, kermes, lac, cudbear, and brazil wood. Madder is a fast, rich-red dye

obtained from the root of the Eurasian herbaceous perennial *Rubia tinctoria*. It was used in a long and complex process to produce Turkey Red on cotton and wool. With different mordants, madder produces a range of colors. Insect dyes include cochineal (*Dactylopius* sp.) from Central and South America, kermes (*Kermococcus vermilis*) of the Mediterranean region, and lac (*Laksbadia chinensis* and *communis*) of Asia. Cudbear (from *Ochrolechia*, *Lasallia*, and *Umbilicaria* spp.) is a lichen dye from northern Europe. Brazil wood (*Caesalpinia* spp.) from Asia and South America produces red, pink, and purple. Of these, madder and cochineal were the most important and the most readily available to contemporary dyers.

Indigo is extracted from the stems and leaves of plants of the *Indigofera* species from India, Central America, and Africa and from woad (*Isatis tinctoria*) from Europe. Indigo, originally from India, is used for cotton, wool, and silk. Woad was an important source of blue in Europe until it was replaced by imported indigo. Indigo from all sources was fermented to produce the dye. The dye must be reduced to be absorbed by the fiber and the fabric exposed to oxygen to develop the blue color.

Log wood (*Haematoxylon campechianum* L.) from Central America was one of the most important black dyes. It also was used for blue and purple. Black walnut (*Juglans nigra*) is used in the twenty-first century to produce substantive black and brown dyes.

Purple dyes have been among the most difficult natural colors to achieve in large quantities. Shellfish (or Tyrian) purple was removed from shellfish of the species *Murex* found in the Mediterranean Sea and *Purpura* found along the coasts of Central America. Orchil, another important purple dye, was derived from lichens.

Mineral dyes include iron buff, iron black, manganese bistre, chrome yellow, and Prussian blue. They were used primarily on industrial fabrics.

### Dyeing with Natural Dyes

Natural dyes are most often processed in this way. The dyestuff is harvested or collected, soaked in water for several hours, and heated to a low simmer for approximately an hour or more to extract the dye. The extract is poured into another pot and water is added to achieve the desired dyebath volume. Wet, pre-mordanted textile is added to the dyebath, which is heated to a low simmer for approximately an hour. After the dyebath is cool, the textile is removed. Some dyers rinse before letting the textile dry. Other dyers prefer to dry the textile for several days before rinsing.

Contact dyeing is an alternate method in which the dyestuff, a tiny volume of water or other liquid, sodium chloride or mordant, and found materials like rusty nails or copper wire are placed in and around the textile that is sealed in a plastic bag or glass jar for several days, weeks, or months. Contact dyed textiles have unusual, one-of-a-kind patterns.

DYES, NATURAL

See also **Dyeing; Dyes, Chemical and Synthetic.**

**BIBLIOGRAPHY**

Casselman, Karen Leigh. *Craft of the Dyer: Colour from Plants and Lichens of the Northeast*. Toronto: University of Toronto Press, 1980.

Gordon, P. F., and P. Gregory. *Organic Chemistry in Colour*. Berlin: Springer-Verlag, 1987.

Liles, J. N. *The Art and Craft of Natural Dyeing: Traditional Recipes for Modern Use*. Knoxville, Tenn.: University of Knoxville Press, 1990.

*Sara J. Kadolph*



**EARRINGS** Earrings, ornaments decorating the ears, have been one of the principal forms of jewelry throughout recorded history. The term usually refers to ornaments worn attached to the earlobes, though in the late twentieth century it expanded somewhat to include ornaments worn on other parts of the ear, such as ear cuffs, and is used to describe pieces of jewelry in earring form, even when they are worn through piercings in other parts of the body (for example, in the nose). The most common means of attaching earrings to the earlobes has been to pierce holes in the lobes, through which a loop or post may be passed. But a variety of other devices have also been used, including spring clips, tensioning devices such as screw backs, and, for particularly heavy earrings, loops passing over the top of the ear or attaching to the hair or headdress.

In many cultures and contexts, earrings have traditionally been worn as symbols of cultural or tribal identity, as markers of age, marital status, or rank, or because they are believed to have protective or medicinal powers. Even when they have served other purposes, however, the primary function of earrings has been a decorative one. As earrings are so prominently placed near the face, and at the juncture between costume and coiffure, they, perhaps more than any other element of jewelry, have been particularly responsive to changes in fashion; as hairstyles, hats, collars, and necklines have risen and fallen, earrings have correspondingly increased and decreased in size and prominence, and during many periods they have been instrumental in balancing and tying together the desired fashionable appearance.

### The Ancient World

In antiquity, earrings were one of the most popular forms of jewelry. The crescent-shaped gold hoops worn by Sumerian women around 2500 B.C.E. are the earliest earrings for which there is archaeological evidence. By 1000 B.C.E., tapered hoop (also known as boat-shaped) earrings, most commonly of gold but also of silver and bronze, had spread throughout the Aegean world and Western Asia. In Crete and Cyprus, earrings were embellished with twisted gold wire, clusters of beads, and pendants stamped out of thin sheet gold.

In Egypt, earrings were introduced about 1500 B.C.E. and were later worn by both men and women. Many Egyptian earrings took the form of thick, mushroom-shaped studs or plugs, which required an enlarged hole to be stretched in the earlobe; these could be of gold, with a decorated front surface, or of humbler materials such as colored glass or carved jasper. Ear studs consisting of two capped tubes that screwed together could be worn alone, but some also had elaborate pendants of gold cornflowers, or falcons with flexible tail feathers inlaid with glass.

In the first millennium B.C.E., Etruscan and Greek goldsmiths brought new refinement and artistry to earrings, which were valued as both an adornment and a sign of wealth. Variations on the hoop were the so-called leech earring, a thick tube secured by a hidden wire, and the Etruscan box-type earring, which encased the earlobe in a wide horizontal cylinder. Disk earrings, with pendants in the form of amphorae (ancient Greek jars), figures of Eros, and decorative beads and chains, were another popular form, joined about 330 B.C.E. by twisted gold hoops with animal-head finials. All of these forms were stamped out of thin sheets of gold and decorated with fine palmettes, scrolls, and flowers in twisted wire and granulation; such earrings were fairly light in weight, but gave an extremely rich effect.

Roman earrings were similar to Etruscan styles until the first century C.E., when new styles with disks and pendants mounted on s-shaped ear hooks appeared. Colored stones and pearls were favored, and earring styles proliferated to satisfy the Roman taste for ostentatious display. At its height, the Roman Empire had the effect of standardizing styles of jewelry over much of the known world; after the center of influence shifted to Byzantium (Constantinople) in C.E. 330, and Roman influence began to decline, local variations once more emerged. Characteristic Byzantine earrings were plain gold hoops with multiple pearl pendants hung on chains, and crescent-shaped earrings of gold filigree.

### The Sixteenth to Eighteenth Centuries

In Europe, earrings virtually disappeared between the eleventh and sixteenth centuries, as hairstyles and head-dresses that completely covered the ears, and later high





**Roman bust of woman wearing earrings.** The Roman Empire's influence at its height of power resulted in the standardization of jewelry styles over much of the known world. © ARALDO DE LUCA/CORBIS. REPRODUCED BY PERMISSION.

ruff collars, made them impractical. Earrings finally began to revive in the late sixteenth century, as ruffs gave way to standing collars. At first, complex enameled designs were popular, but improved techniques of gem cutting soon shifted the emphasis to faceted diamonds. In the seventeenth century, large, pear-shaped pearl pendants were a favorite earring style, and those who could afford to do so wore two in each ear. It was also fashionable to wear pendant earrings on strings or ribbons threaded through the earlobes and tied in bows, and to tie ribbon bows at the tops of earrings to achieve the same effect. Similar earring styles were also worn by fashionable gentlemen, but usually in one ear only.

By the late seventeenth century, earrings had become an essential element of dress, and larger and more elaborate forms began to develop. Two of these became the dominant styles of the eighteenth century: the girandole, in which a single top cluster branches out like a chandelier to support three pear-shaped drops, and the pendeloque, a top cluster with a long single pendant. New sources of diamonds, along with new methods of cutting them, developed early in the eighteenth century, made them the material of choice for jewelry, and high-quality paste imitations were also available. Glittering girandoles

and pendeloques, visually tied to the ears by stylized ribbon bows of diamonds set in silver, effectively balanced the high, powdered hairstyles of the period. Despite their refined and delicate appearance, such large earrings were quite heavy; some had additional rings soldered to the tops, permitting the wearer to take some of the weight off of her ears by tying the earrings to her hair.

### The Nineteenth Century

When the neoclassical style of dress and simpler hairstyles came into fashion at the end of the eighteenth century, earrings became lighter and simpler. Jewelry of cut steel, seed pearls, Berlin iron, and strongly colored materials such as coral and jet, harmonized well with neoclassical fashions, and classically inspired cameos and intaglios were set in all kinds of jewelry. Heavy girandoles gave way to pendant earrings composed of flat, geometric elements connected by light chains. "Top-and-drop" earrings, composed of a small top element attached to the ear wire, from which a larger, often teardrop-shaped element is suspended, also came to the fore around 1800, and remained the most popular earring style throughout the nineteenth century. Matched sets of jewelry, known as *parures*, assumed new importance in the nineteenth century, and they were available even to women of modest means. These sets usually included at least a matching necklace or brooch and earrings, but could also include bracelets, buckles, and a tiara or tiara-comb.

In the 1810s and 1820s, the trend toward lighter and more delicate jewelry continued, and settings of gold filigree or elaborate wirework (known as *cannetille*) were very popular. In the 1820s, a romantic interest in the past also inspired jewelry designers to revive historical styles from the ancient world to the eighteenth century, and a modified version of the girandole earring returned, along with elaborate gothic tracery and rococo-revival scrollwork. As hairstyles became more elaborate in the 1830s, earrings became more prominent, with small tops and long drops reaching nearly to the shoulders. In spite of their size, these earrings were fairly light in weight, owing to lightweight settings of gold *cannetille* or of *repoussé* (embossed relief raised from behind with a hammer), which had largely replaced *cannetille* by the 1840s. Earrings with long, torpedo-shaped drops of carved gemstones with applied gold filigree were also popular, many with detachable drops to allow the tops to be worn alone.

In the late 1840s and through the 1850s, a new hairstyle, with hair parted in the middle and gathered to the back of the head in loops that covered the ears, caused a virtual disappearance of earrings. Around 1860, once again owing to a return to upswept hairstyles, long pendant earrings made a comeback, and through the 1860s and 1870s they were produced in an astonishing variety of styles. One major theme was historical revival, with Egyptian and Classical styles particularly popular. Some revival earrings, such as those produced by the Castellani family in Rome, were fairly faithful reproductions

of recent archaeological discoveries; others were fanciful pastiches of classical earring forms, architectural elements, and other motifs such as amphorae. Earrings with carved classical reliefs of coral or lava, or Roman glass micro-mosaics, were very fashionable, and were often brought back as souvenirs by travelers to Italy. Other popular styles were naturalistic renditions of leaves, flowers, insects, and birds' nests in gold, enamel, and semiprecious stones; enameled renaissance-revival styles; and, for more precious gems, floral sprays and cascades. A new style in the 1870s was the fringe or tassel earring, with a graduated fringe of pointed drops suspended from a large oval pendant.

In the last two decades of the nineteenth century, large pendant earrings went out of fashion, in part because they were incompatible with the newly fashionable high dress and blouse collars, and with the elaborate "dog collar" necklaces worn for evening, which almost completely covered the neck. Small single-stone and cluster earrings, either firmly mounted to the ear wire or mounted as pendants to move and catch the light, were the most commonly worn style through the early twentieth century. The most fashionable earrings of all were diamond solitaires, which became more available after the opening of the South African diamond fields in the late 1860s. New cutting machines and open-claw settings, both of which increased the amount of light reflected by diamonds and made solitaire earrings more appealing, were developed in the 1870s. To prevent valuable diamond earrings from being lost, catches were added to secure the bottoms of the ear wires. Another innovation, first patented in 1878, was the earring cover, a small hinged sphere of gold, sometimes finished in black enamel, which could be snapped over a diamond earring to protect it from loss or theft. By the end of the century diamond ear studs (also called screws), with a threaded post passing through the ear, and held securely in back by a nut screwed onto the post, were also popular.

### The Twentieth Century

By 1900, as earrings declined in size and importance, many women stopped wearing them altogether. Some commentators denounced ear-piercing as barbaric, and women who pierced their ears were considered "fast," or not quite respectable. (In the United States, some of the reaction against pierced ears may be credited to the desire of "native" Americans to distinguish themselves from the large numbers of immigrant women, almost all with pierced ears, who were arriving from Europe at the time.) In spite of piercing's negative image, small screw earrings continued to be worn, and new screw-back fittings, which could be tightened onto unpierced earlobes, were available for those who did not wish to pierce their ears. Around 1908, pendant earrings were revived, but with light, articulated drops of smaller stones rather than single-stone drops; diamonds, pearls, and stones matching the color of the costume were the most popular materials.

The earring revival continued into the 1910s, aided considerably by a growing acceptance of costume jewelry. Jewelry could now be selected for its decorative value rather than its intrinsic value, and women could afford to own many pairs of earrings to match particular costumes; the rise of costume jewelry also made ear piercing less necessary, as women were less concerned about losing inexpensive earrings. (Many women, as was still true in the early 2000s, also had adverse reactions to the cheaper metals used in costume jewelry, which made pierced earrings seem less practical.) The fashion for the Oriental and exotic inspired by Paul Poiret and the Ballets Russes was reflected in bead necklaces and long drop earrings of Chinese amber, jade, black and red jet (glass), and carved tortoiseshell. Empire-revival fashions also inspired a revival of nineteenth-century jewelry styles and materials, including cut steel and cameos.

By the early 1920s, earrings were again almost universally worn, and the range of exotic styles had expanded to include hoop and pendant earrings of Spanish or Gypsy inspiration, Egyptian styles inspired by the discovery of King Tutankhamen's tomb in 1922, nineteenth-century antiques, and picturesque "peasant" styles from around the world. As reported by the *New York Times* in 1922, in the 1920s earrings could "no longer ... be considered as an article of jewelry; they are *the* article of jewelry." With dress styles now comparatively simple, and many women bobbing their hair, earrings were considered an essential finishing touch—a means both of filling in the area between the ear and shoulder and of expressing the wearer's personality. Bold geometric pendant earrings, made of diamonds and platinum contrasted with strongly colored materials such as onyx and lapis lazuli, were displayed at the Exposition Internationale des Arts Décoratifs in 1925, and this style, which became known as Art Deco, remained popular for both precious and costume earrings for the remainder of the decade.

In the early 1930s, although there was no sudden change in style, earrings began to move closer to the head again, partly in response to smaller, close-fitting hats and the return of high, tied and ruffled collars. Another major influence was the introduction, in 1931, of clip fastenings for earrings, which made it possible to concentrate ornamentation over the earlobe, and compact designs following the line of the ear soon became popular. Matching earrings, bracelets, and other jewelry made of brightly colored bakelite were another signature 1930s look. For evening, long earrings in Art Deco style were still popular, but earrings with white stones (diamonds or pastes) were now the most popular, and the pendants now added volume by branching out to the sides, in a modern version of the girandole, or "chandelier," style.

In the 1940s, compact clips or screw backs, often made with a matching brooch, were the dominant earring style. Gold, strongly colored stones, and bolder, more sculptural forms were now preferred, in keeping with the



**Gold hoop earring.** Hoops are the earliest known form of earrings, dating from about 2500 B.C.E., and they have been a popular style for most of the preceding centuries. © IMAGES.COM/CORBIS. REPRODUCED BY PERMISSION.

padded shoulders and highly structured coiffures of the period. Close-to-the-ear styles, with clip or screw backs, continued to be the most popular in the 1950s, but settings became more delicate, to harmonize with the more deliberately feminine fashions in the years following Christian Dior's 1947 "New Look" collection. An important look of the 1950s was the matched set of choker necklace and button earrings, and these were produced in a wide variety of styles and materials, including newly developed plastics. White and colored rhinestones were popular, as were beads and faux pearls of all kinds, colors, and finishes, often looped in multiple strands around the neck, and fastened with a clasp of clustered beads matching the earrings. Ear piercing, while still not common, began to revive in the early 1950s; in the United States, the trend began as a fad among college girls, and Queen Elizabeth II set an example for many in England when she had her ears pierced in order to be able to wear diamond earrings she received as a wedding present in 1947.

In the 1960s, as in the 1920s, clean-lined dresses and hairstyles, including the long, straight hair popular later in the decade, provided an ideal background for large and decorative earrings. Earrings were again among the most important of accessories, and were often designed to stand alone, rather than as part of a matched set. In both

fine and costume jewelry, abstraction was popular, and creative design, visual impact, and wit were often considered more important than the intrinsic value of jewelry. Hoop earrings were one of the signature styles of the decade, and they appeared in designs inspired by tribal jewelry, enormous space-age styles of chrome and plastic, and kinetic designs of concentric, articulated rings. Ethnic styles, particularly from India and the Near East, were also popular, and delicate dangling earrings helped to propel handcrafted sterling silver jewelry, which had been growing in popularity since the 1940s, into the fashion mainstream.

By the early 1970s, the new fashionable ideal was the "natural look," and large costume earrings disappeared in favor of smaller and more delicate earrings, usually of silver or gold, and almost always worn in pierced ears. In terms of design, earrings remained fairly inconspicuous throughout the decade, though they were given new prominence by the fashion for multiple piercings in the same ear, which began as a teenage fashion around the middle of the decade, and continued into the twenty-first century to be a popular way to wear earrings. Earrings worn in the upper part of the ear, and ear cuffs, which grip the edge of the upper ear, were fashions introduced late in the decade. The 1970s was also when earrings for men returned to fashion after a 300-year absence; earrings had continued to be worn by sailors, by some homosexual men, and by members of groups such as motorcycle gangs, but many more men now began to wear single earrings largely for their decorative value.

Large and flashy earrings, both real and frankly fake, returned in the 1980s, to balance the bolder shapes and colors, padded shoulders, high-volume hairstyles, and dramatic makeup then in fashion. Chunky button earrings covering the lower half of the ear and large pendant hoops were popular styles, and common finishes were shiny gold, bright colors contrasted with black, and a variety of bronzed and iridescent metallic finishes. Even relatively understated earrings tended toward strong shapes, worn close to the earlobe; though most women still had pierced ears, clips were popular because they kept earrings close to the head, and because they distributed the weight of heavier styles.

In the early 1990s, silver, brushed finishes, and simple, elegant earrings began to succeed the shiny gold and jagged shapes of the 1980s, in keeping with the monochromatic and minimalist mood of fashion. At the same time, the trend toward simple, versatile clothes that could be dressed up or down inspired women to use elaborate or unusual earrings to vary the effect of an ensemble, and earring styles proliferated. Since the mid-1990s, there has not been a dominant style in earrings, although historical revivals have been an important trend; the popularity of glamorous "chandelier" earrings inspired the return of girandole and top-and-drop designs from the eighteenth and nineteenth centuries, along with the more familiar kinetic designs of



the 1920s and 1960s. Earrings have become a popular form of personal expression, and how and when they are worn, along with their function within an ensemble, became largely a matter of personal choice.

See also **Bracelets; Brooches and Pins; Costume Jewelry; Jewelry; Necklaces and Pendants.**

#### BIBLIOGRAPHY

- Andrews, Carol. *Ancient Egyptian Jewellery*. London: British Museum Publications, 1990.
- Bury, Shirley. *Jewellery 1789–1910—The International Era*. 2 vols. Woodbridge, Suffolk, U.K.: Antique Collectors' Club, 1991.
- Fales, Martha Gandy. *Jewelry in America 1600–1900*. Woodbridge, Suffolk, U.K.: Antique Collectors' Club, 1995.
- "Fashions: Earrings Essential Now for Smart Dressing." *New York Times* (23 July 1922): 80.
- Flowers, Margaret. *Victorian Jewellery*. New York: Duell, Sloan and Pearce, 1951.
- Mascetti, Daniela, and Amanda Triossi. *Earrings from Antiquity to the Present*. London: Thames and Hudson, Inc., 1990.
- Scarisbrick, Diana. *Jewellery*. London: B. T. Batsford, Ltd., 1984.
- . *Tudor and Jacobean Jewellery*. London: Tate Publishing, 1995.
- Walters Art Gallery, Baltimore. *Jewelry, Ancient to Modern*. New York: Viking Press, 1979.

Susan Ward

**ECCLESIASTICAL DRESS** The term "ecclesiastical" derives from the Greek *ekklesiastikos*, from *ekklesia*, an assembly or meeting called out, which in turn derives from *ekkalein*, to call forth or convoke, *ek*, out, and *kalein*, to call. This assembly often referred to the Christian Church and its clergy. Ecclesiastical dress refers here to garments worn by Christian leaders, including members of monastic orders—as distinct from the laity—from the early Christian era until the present, not only in the West but also in all parts of the world where the Christian religion is practiced.

#### Historical and Cross-Cultural Examples

The origins of ecclesiastical dress have been debated, with some attributing early forms to garments worn by Jewish religious leaders, while others have argued that these vestments derived from everyday Roman dress worn during the early Christian era. In the early 2000s, the latter explanation prevails. Different forms of ecclesiastical dress have developed with the expansion and elaboration of the Western and Eastern Churches. The forms and meanings of ecclesiastical dress have changed over time and have variously been used to separate the mundane from the spiritual, to emphasize the glory of God through beautiful raiment, to express religious hu-

mility and piety, and to identify individuals within the church hierarchy.

Depictions of early Christians in the Catacombs of St. Domitilla in Rome include a painting of the Good Shepherd, wearing a white tunic or *tunica*, a rectangle of white material—made either from linen or wool—with a girdle holding it in place. The secular use of this garment was as an undergarment, covered by a toga. Church leaders adopted the dalmatic, also a tunic-like garment, worn in ancient Rome, by the eighth century as an upper-vestment worn by bishops, deacons, and sub-deacons. The *paenula*, which was worn as an outer garment, was the secular precursor of the chasuble, a term derived from the Latin, *casula*, little house or cottage—a circular piece of cloth with a head opening and sometimes a hood, which protected its wearer like a house. It was formally decreed as an outside garment for clergy in 742 by the Council of Ratisbon. One of the earliest examples of the wearing of these garments by church leaders come from depictions of the chasuble or *paenula*, dalmatic, and *pallium* (a long woven band of white wool, decorated with crosses) in the sixth century mosaic from the Church of St. Apollinaire, in Ravenna.

Ecclesiastical dress in the West and East developed along the same lines until the eleventh century; however, there were differences in the meanings and uses of these garments. In the West, vestments were worn to express Christian beliefs about the sacred and the mundane, as well as to distinguish the roles of clergy within the Church hierarchy. In the Eastern churches, these ideas were also present although the belief that ecclesiastical vestments literally represented the garments of Christ also existed. This belief was visually expressed, for example, in the vestment known as the *sticharion*, a tunic-like garment that had its counterpart in the alb, a white linen tunic used as a vestment in the West by the twelfth century. The *sticharion* had two bands of red ornamentation, known as *clavi*, which referred to the wounds made on Christ's body during the Crucifixion. Similarly, embroidery at the ends of the *sticharion*'s narrow sleeves was meant to represent the manacles with which Christ's wrists were bound. While embroidered pieces known as apparels were used on albs, dalmatics, and tunics to represent Christ's stigmata when placed at the end of sleeves and at hems, the practice of incorporating this form of ornamentation on vestments was gradually replaced by the use of lace in Western vestments during the sixteenth century.

Vestments used in the Eastern Church include the *phelonion*; the *saccos* (a tunic with wide sleeves, worn by patriarchs); as well as the priestly insignia—the *omophorion*—the Western *pallium*—worn by bishops; two forms of stole—the *epitrachilion* and the *orarion*, worn by priests and deacons, respectively—and the square ceremonial cloth known as the *epigonation*, symbolically representing "the Sword of God," worn only in the Greek and Armenian churches by vested bishops. The *phelonion*, as depicted in medieval frescoes, was a round cloak sim-



**Embroidered chasuble.** Long a staple of the Roman Catholic Church, the chasuble has been worn by clergy members since at least the sixth century. © PHILADELPHIA MUSEUM OF ART/CORBIS. REPRODUCED BY PERMISSION.

ilar to the medieval bell-shaped chasuble. Initially, it was made from white or colored materials alone, but by the eleventh century it was embroidered with small crosses. The art of Byzantine embroidery of ecclesiastical dress flourished during the period of the Palaeologus Dynasty, from the mid-thirteenth to mid-fifteenth century. Byzantine embroiderers used gold, silver, and silk thread to depict a range of scenes and personages from the Old and New Testaments on silk vestments. Several extant embroidered *sacci* from the fourteenth and early fifteenth century illustrate this Byzantium style of vestment, including two *sacci* associated with the Metropolitan Photius of Moscow (1408–1432). One side of the Grand *Saccus* of Photius includes heavily embroidered portraits of the Grand Prince of Moscow, along with a depiction of the Crucifixion, the Prophets Isaiah and Jeremiah, and three Lithuanian martyrs, all on a blue silk background, with the embroidery outlined with pearls.

The Byzantine or Eastern Orthodox Church also includes the Syrian, Armenian, Nubian, Ethiopian, and the Coptic Churches, with their own traditions of ecclesiastical dress. There was considerable overlap in the vestments of the early Coptic Church with those of the other Byzantine churches. For example, the *sticharion* (tunic), *orarion* (stole), *epitrachelion* (stole), and *phelonion* (chasuble) were used by both. Later developments, particularly the introduction of the stole-like *ballin* that was worn by priests and bishops during church services, distinguished Coptic practice. Much of what is known of early ecclesiastical dress worn in these churches comes from texts, illuminated manuscripts, and wall paintings.

During the Medieval Period, ecclesiastical dress in the Roman Catholic Church included a range of vestments used in relation to church services: the alb, cassock (an ankle-length garment with sleeves), chasuble, cope (a capelike garment used as outerwear), dalmatic, hood (a hood attached to cope, often nonfunctional), maniple (a folded cloth or narrow strip worn over the left shoulder of bishops, priests, deacons, and sub-deacons during Mass), mitre (a cap worn by bishops often with two tabs—lappets—of cloth hanging from the back), stole (a long strip of cloth, worn in particular ways to identify members of priesthood), and surplice (a loose, white, outer ecclesiastical vestment usually of knee length with large open sleeves). It was also during the thirteenth century that the English embroidery of ecclesiastical dress flourished, referred to as *Opus Anglicanum*. In continental Europe, vestments made of patterned silk velvets with intricately embroidered orphreys, decorative woven bands (used in the forms of crosses, pillars, and simple selvage bands on copes, dalmatics, and chasubles) were also produced at this time. With the separation of the Church of England from Rome in 1534, the embroidery of vestments in England fell into decline, to be resumed there during the nineteenth century Gothic Revival.

### Controversies Relating to Ecclesiastical Dress

During periods of religious reform and political change, ecclesiastical dress has often served as a symbol of the old regime, which must be replaced or denigrated by reformers, while those opposing the abandonment of older forms of ecclesiastical dress (and the church doctrine associated with them) have sought to maintain them. One famous example of a controversy was the debate over the white linen surplice, which became a symbol of Roman Catholicism during the Protestant Reformation in sixteenth-century England. With the separation from the Roman Catholic Church made final by an act of Parliament in 1534 and the subsequent establishment of the Church of England during the reign of Queen Elizabeth I (1558–1603), the surplice became the universal vestment of all Anglican clergy in 1563. Yet surplices, along with copes, albs, and chasubles, were seen as remnants of “popish dress” by Protestant religious reformers such as the Puritans, Methodists, and Baptists. Tracts with titles

such as “A briefe discourse against the outvvarde apparel and ministring garmentes of the popishe church” written by Robert Crowley in 1578 were published and some Protestant leaders were imprisoned for refusing to wear a surplice during church services. These leaders preferred to wear simple, everyday dress, which did not distinguish them from the laity or from everyday affairs. Nonetheless, Anglican Church leaders preserved distinctive ecclesiastical garments, particularly those that continued to be used for royal services. During the seventeenth century, English Protestant ecclesiastical dress was modeled on contemporary dress fashions—specifically, a simple black suit, including a coat, waistcoat, and knee breeches, and a white neckcloth, while Anglican clergy wore cassocks and gowns. However, during the 1840s, those associated with the Gothic Revival in England sought to reinstate the practices of the Church of England during the reign of King Edward VI. In 1840, the Bishop of Exeter directed Anglican clergy to wear surplices, which led to the Surplice Riots when mobs in Exeter pelted those wearing surplices with rotten eggs and vegetables. The Bishop’s order was rescinded, but by the second half of the nineteenth century, ecclesiastical dress—including surplices, copes, and albs—was incorporated into Anglican services, modeled after gothic vestments design, as interpreted by Victorian artists. This revival of the use of vestments coincided with the florescence of the Arts and Crafts movement during the nineteenth century in England. One prominent member of this movement, William Morris, who as an Anglo-Catholic, had supplied specially designed vestments to the Roman Catholic Church following the Catholic Emancipation of 1829. In 1854, the Ladies’ Ecclesiastical Embroidery Society was organized to produce embroidered replicas of medieval designs (Johnstone 2002, p. 123). Along with these specialized workshops, ecclesiastical dress, which was mass-produced and mass-marketed through catalogs, also became available, in part, due to the increasing demand for such vestments from missionaries working in the British colonies during this period.

Another example in which ecclesiastical dress became the focus of controversy took place in Mexico. Prior to the Mexican Revolution, the wealth and political power of the Roman Catholic Church was evident in ornate cathedrals and ecclesiastical dress. During the second half of the eighteenth century, dalmatics, copes, chasubles, and stoles made with silver and gold threads and elaborately embroidered with the emblem of the Convent of Santa Rosa de Lima, were probably made in the Mexican city of Puebla. While the Church had considerable popular support, its extensive landholding and its association with the political elite contributed to the view that it was an impediment to economic progress and social justice. During the Mexican Revolution that began in 1910, a series of anticlerical measures were taken, culminating with the writing of the Constitution of 1917, which provided for the confiscation of church lands, the

replacement of religious holidays with patriotic ones, and the banning of public worship outside of church buildings, including processions (Purnell 1999, p. 60). While these laws were enacted, they were not always strictly enforced until 1926, when Government leaders sought to further restrict the power of the Church through the Calles Law. This law outlawed Catholic education, closed monasteries and convents, and in Article 130, restricted the wearing of ecclesiastical dress in public. When the Mexican Episcopate ordered the closing of churches in response to the Calles Law, a popular uprising known as the Cristero Rebellion resulted, primarily in central West Mexico, during the period from 1926 to 1929. With the state’s agreement to stop its insistence on registering priests and with the restoration of religious services—including the wearing of ecclesiastical dress—the rebellion ceased.

Ecclesiastic dress has also served as a vehicle for expressing anticolonial sentiments in Africa, during the nineteenth and twentieth centuries. However, many early African Christian converts did not reject European styles of vestments, but rather incorporated indigenous elements into ecclesiastical dress as an expression of their discontent. In colonial Nigeria during the first half of the twentieth century, converts who occupied leadership positions in Roman Catholic and orthodox Protestant churches—primarily, Anglican, Methodist, and Baptist—generally wore the tailored garments (cassocks, chasubles, surplices, copes, and mitres) used by home church leaders. These garments distinguished Christian converts from those practicing various forms of indigenous religion, which had their own, often untailed, dress traditions. Yet some early Nigerian Christian leaders sought to assert independence from Orthodox churches over doctrinal disputes, often concerning polygynous marriage. Establishing their own churches, referred to generally as African Independent Churches, they did not entirely abandon tailored, Western-style vestments. Rather, these leaders developed distinctive ecclesiastical dress forms that identified these new churches and emphasized particular aspects of their doctrine. For example, Bishop J. K. Coker, the founder of the African Church, incorporated indigenous textiles, for example handwoven narrow strip cloths, into ecclesiastical dress. Leaders of the Independent African Churches such as Bishop Coker were the predecessors of nationalist independence leaders who supported secular independent states based on Euro-American models combined with African social and cultural elements.

The controversies surrounding freedom of religious expression have, at times, been moderated through gradual change in ecclesiastical dress, which reflected church leaders’ responses to changing political and social contexts. For example, early members of the Marist Brothers apostolic movement, which was founded in France by Father Marcellin Champagnat (1789–1840), wore “a sort of blue coat, . . . black trousers, a cloak, and round hat” garments, which he believed were imbued with spiritual power that



protected its wearers from anticlerical attacks. While these vestments helped to attract and visually to distinguish new members during the post-revolutionary period in France, they also gave followers a sense of special protection. However, with the incorporation of the Marist Brothers' Institute as a religious order of the Roman Catholic Church in 1863, Marist ecclesiastical dress came to lose its mystical aspects and shifted to a uniform prescribed by the Church authorities, including a black soutane, white rabat, and a black cloak. With the Second Vatican Council in 1962, Marist Brothers' ecclesiastical dress again changed as a loss in church membership suggested a simpler, less-clerical style—such as a suit—would be more appropriate to modern worship. However, by 1987, some Marist priests returned to wearing the soutane, while others continued to wear secular suits, depending on their preferences and those of their parishioners. This shift from distinctive ecclesiastical dress that identified Catholic orders according to particular configurations and types of garments to current secular dress styles, indistinguishable from contemporary clothing is also evident in Western nuns' garb. Western nuns or Women Religious, whose name as well as dress changed with Vatican II, as of the turn of the twenty-first century wore everyday garments as a way of emphasizing their role in modern society, rather than their separation from it.

### Role in Contemporary Society

In the West, this shift back to simplicity in Roman Catholic and Anglican ecclesiastical dress is expressed in simple, fully-cut vestments made from materials using natural fibers, reminiscent of those of the early Christian era. A leading figure in this movement is Sister M. Augustina Fluëler, a Capuchin nun, associated with the Cloisters of St. Klara, in Switzerland. One chasuble that she designed was made of off-white, plain-weave wool, with a stole of plain-weave silk with two embroidered crosses in gold thread. In a simple and elegant wool and silk dalmatic, she used narrow bands of rose and purple as edging, with broader alternating bands of these colors incorporated into the sleeves.

Other expressions of this simplicity of vestment design may be seen in the embroidered works of Beryl Dean Phillips (England), in the handwoven chasubles of Barbara Markey Wallace (United States) and copes and mitres with lappets of Lennart Rodhe (Sweden), in the painted chasubles of Willam Justema (United States) and in the appliquéd chasubles of Henri Matisse (France). While utilizing different techniques—embroidery, handwoven twills, overshot, and tapestry, painting, and appliqué in their production, they share a spareness of patterning—often of crosses or of stylized floral patterns with little background ornamentation—and of natural materials—silk, wool, cotton, and linen. The design and production of these vestments by craftswomen and men underscores the belief that the careful and creative making of objects used in divine service is in itself a form of worship. These

vestments convey “a certain splendid sobriety,” the essence of the reform of the Roman Catholic Church associated with the *General Instructions* of 1962 that emphasize that the beauty of ecclesiastical vestments derives from “the excellence of their material and the elegance of their cut” (Flannery, p. 197), rather than from their elaborate ornamentation or color. The concept of the simple yet distinctive beauty of vestments coincides with Anglican views of contemporary ecclesiastical dress, the use of which should mark special religious events, but without ostentation.

### Ecclesiastical Dress and Globalization

The counterpart to simplicity of ecclesiastical dress produced by vestment makers in the West, which in the Roman Catholic Church was associated with the reforms instituted by Vatican II, is seen in the appearance of individual national churches, whose identities are expressed, in part, through use of local materials in vestments. The basis for the local development of ecclesiastical dress is found in the General Instruction on the Roman Missal:

304. Bishops' Conferences may determine and propose to the Holy See any adaptations in the shape or style of vestments, which they consider desirable by reason of local customs or needs.

305. Besides the materials traditionally used for making sacred vestments, natural fabrics from each region are admissible, as also artificial fabrics which accord with the dignity of the sacred action and of those who are to wear the vestments. It is for the Bishops' Conference to decide on these matters. (Flannery, p. 197)

The use of local materials may refer to particular techniques—types of weaving, embroidery, or drawn-work—and types of materials—cotton, wool, lurex, among others. In the Philippines, for example, locally made vestments are constructed from handwoven cloth of pineapple (*piña*) and *abaca* (commonly known as Manila hemp) fibers. Abaca fibers are processed from the long plant stalks and the finely spun threads are handwoven into plain-weave abaca cloth, with designs made through discontinuous supplementary weft patterning (*sinuksok*) and resist-dyed ikat techniques. Abaca cloth made into vestments may also be embellished with a range of decorative techniques including, embroidery, appliqué, beadwork, and cut-and drawn work. Chasubles, copes, stoles, and mitres with lappets made from cloth handwoven with *piña* fibers are similarly decorated. A new type of vestment was introduced in the Philippines in the 1970s, the chasuble-alb, known in the Philippines as the tunic. This vestment, worn with a stole, serves as both an alb and a chasuble, thus limiting the number of vestments needed by concelebrants and reducing the discomfort of wearing multiple layers of cloth in a tropical climate. However, not all liturgists have agreed with this change and in 1973, the Catholic Bishops of the Philippines restricted its use to particular circumstances.

In Nigeria, there has been a shift from the purchase of ecclesiastical dress, mainly from Great Britain to the production of vestments in Nigeria itself, using locally woven narrow-strip cloth and batik-dyed textiles. Chasubles, mitres, and stoles, machine-embroidered with depictions of scenes and texts from the Old and New Testament as well as with more abstract shapes and symbols, may be produced by individual specialists or by nuns working in convent workshops. One woman, Mrs. Anne Salubi of Ilorin, a university-trained artist, is renowned throughout Nigeria for her chasubles, which have been commissioned by bishops in various Nigerian cities as well as in Ireland. During the recent visit of Pope John Paul II to Nigeria, Mrs. Salubi was commissioned to make the chasuble given to the Pope during his visit. Anglican and Methodist church leaders in Nigeria have also begun to incorporate handwoven cloth strips into ecclesiastical dress, using them mainly as stoles in different colors used for particular church seasons, with simple machine-embroidered design such as crosses. Smaller workshops combine the production of church stoles and choir robes with academic gowns.

The mass-production and mass-marketing of ecclesiastical dress through catalogues reflect the accelerating interdependence of nations and communities in a world system linked through economics, mass media, and modern transportation systems. For example, Mexico-style ecclesiastical vestments are marketed on the website of the Mexican American Cultural Center, of San Antonio, Texas, which includes embroidered chasubles produced by the congregation of Sisters in Guadalajara, Mexico, as well as stoles made with locally handwoven *zarape* cloth strips. The web not only facilitates the marketing of vestments but also serves as a source of materials, such as metallic threads, which might not be available locally. Thus, globalization allows for specialization of local styles of ecclesiastical dress while also expanding the availability of supplies and the marketing of these national or ethnically identified vestment styles to communities outside the immediate homeland.

### Conclusion: Main Themes

Several recurrent themes have emerged during the long history of ecclesiastic dress. Early church dress consisted of simple forms, using natural materials, in part due to the persecution of Christians and in part due to a lack of well-defined church doctrine on dress. By the third century, with the acceptance of Christianity by Constantine, there was a shift toward ecclesiastical dress, which both identified wearers as Church leaders and also indicated their rank within the church. These two tendencies—one, toward visually portraying church hierarchy with ever more elaborate ecclesiastical dress, exalting the worship of God and Christ through beautiful vestments; the other toward downplaying distinctions between church leadership and laity through simple, unadorned styles of dress and, in the case of the Protestant Reformation, aban-



**Pope John Paul I wearing richly detailed epitrachelion.** The epitrachelion is the second fundamental vestment in the Christian Church and is worn by both priests and bishops. AP/WIDE WORLD PHOTOS. REPRODUCED BY PERMISSION.

doning ecclesiastical dress entirely—have been expressed in various ways over the centuries. A related theme, uniformity and individualism, has also been expressed in ecclesiastical dress. For example, U.S. “women religious” have abandoned wearing habits, in order to address the contradiction between American social ideals of secular individualism and the religious uniformity that ecclesiastical dress represent, and to function more effectively in the secular world. These themes also reflect the relationship of changes in ecclesiastical dress and political, economic, and social changes, with reformers tending toward simplicity and contemporary secular garments, and with counter-reformers tending toward more elaborated vestments which reflect a nostalgia for past “traditions” in preference to secular “modernity.” Contests between church and state have also been reflected in controversies over the wearing of ecclesiastical vestments.

The themes of worldliness and spirituality, unity and individualism, and simplicity and elaboration, have been concerns expressed largely in terms of vestment use in Western and Eastern Churches in Europe and in the United States. The use of ecclesiastical vestments as expressions of anticolonial sentiments and, more generally, to counter assumptions about Western cultural hegemony are themes that emerge in Christian communities

in Africa, Asia, and Latin America, where conversion to Christianity has been more recent. European ecclesiastical dress has been viewed as a sign of modernity but also as a symbol of acquiescence to Western power. With national independence and with the later reforms of Vatican II introduced in 1962 and thereafter, African, Asian, and Latin American Roman Catholics began to incorporate locally produced vestments using indigenous materials into religious worship, supporting modern local and Roman Catholic identities simultaneously.

Ecclesiastical dress is especially appropriate for asserting different identities and distinctions among individuals and groups because of the range of materials, colors, embellishments, and styles into which this dress can be shaped. Ecclesiastical dress may also be used to construct new identities that acknowledge cultural distinctiveness, while at the same time emphasizing membership in a universal world church. The continually changing configurations of vestments used in Christian worship attest to this aspiration for unity and distinction. The attempts to find an acceptable balance of old and new ways, of simplicity and ornamentation, of indigenous and foreign ideas and practices, reflect a striving for the harmonious unity of humankind and at the same time, a need for distinctive identities and beliefs, both expressed through the use of ecclesiastical dress.

See also **Religion and Dress.**

#### BIBLIOGRAPHY

- Innemée, Karel C. *Ecclesiastical Dress in the Medieval Near East*. Leiden, New York: E. J. Brill, 1992.
- Mayo, Janet. *A History of Ecclesiastical Dress*. New York: Holmes and Meier Publishers, Inc., 1984.

*Elisha P. Renne*

**ECONOMICS AND CLOTHING** The economics of clothing involve three processes: production, making the clothing; distribution, getting the clothing from the maker to the consumer; and consumption, actually using the clothing. Although consumption drives production and distribution, the three processes are in many ways inseparable. The system is fiercely competitive at all stages, partly but not entirely because clothing is a fashion good. Although some plain utilitarian garments may seem to be little affected by fashion, their production and distribution are highly competitive as well.

In developed nations, fashions in clothing and other goods and services change so rapidly and in so many ways that it's difficult to keep track. People may assume that, in ancient cultures or isolated societies, styles of clothing, dwellings, tools, and customs remained static for generations. Yet scholars discern small incremental changes when they can find sufficient data. Major features of the economics of clothing today have roots in the distant past.

Perhaps in prehistoric times, or on the frontier of pioneer America, isolated family units produced all their own clothing. But in fact, most people probably hunted in groups for large, fur-bearing animals and specialized in doing certain tasks. Production of apparel has always been highly labor-intensive, and evidence of specialization appears early.

Twenty thousand to twenty-six thousand years ago, in the north of what is now Russia, a young man was buried in a shirt and trousers elaborately embroidered with ivory beads. At roughly the same time, in what is now France, craftsmen were carving delicate sewing needles from bone. To shape and drill beads or make needles with the materials and tools available then would require both inherent manual skill and considerable practice. Probably only one person in a settlement or a cluster of settlements mastered the skills for such work; others did tasks such as harvesting and processing fibers or skins and assembling garments. Presumably these specialists bartered what they made for goods and services of other group members. Specialization optimizes use of individuals' time and abilities and makes better quality clothing possible for all. Scientists who uncovered the grave of the youth in the beaded outfit concluded that he was a person of importance—he or his family possessed wealth or power to command a costume of such splendor. Clothing already expressed status, more than 200 centuries ago.

#### A Global Economy

The apparel economy is truly global. From earliest times, it has extended to the limits of human occupation. In each geographic area, people exploited native plants, animals, and minerals. The Chinese learned the secrets of the silkworm; linen grew in the Nile valley, cotton in the Indus River valley; Mesopotamians raised sheep for their wool. Shellfish found at the eastern end of the Mediterranean sea provided precious purple dye. Polar cultures relied upon the furs and skins of local creatures, both land and sea. Natives of what is now the Pacific coast of Canada used cedar bark garments to shed rain; some peoples made cloaks of grasses.

In time, precious textiles, furs, and ornaments moved by long, difficult overland trade routes or hazardous water voyages. Later, textile centers evolved where people demanded large quantities of luxury fabrics and were willing to pay well for them. Byzantium, as well as Sicily, produced fine silks during the Middle Ages, although they were far from the original sources of silk. Even so, proximity of raw materials gave some geographic areas advantages over others. Certain districts in Italy, Germany, Flanders, and England became textile centers, specializing in locally produced fibers and distinctive techniques. In medieval times, traveling merchants transported fine textiles from production centers to regional trade fairs on a regular basis.

The ramifications of trade in textiles and other apparel materials extended far beyond the obvious. In an-





## THE CONCEPT OF FASHION

“Fashion” is a complex concept, but economic analyses require simple, operational definitions. Therefore this essay uses definitions based on those stated by Paul Nystrom in his 1928 book, *Economics of Fashion*. He defined “style” as “a characteristic or distinctive mode or method of expression in the field of some art” (p. 3) and “fashion” as “the prevailing style at any given time” (p. 4). A source of confusion is that the word “fashion” can be used to mean either “content” or “process.”

In writing or speech, the word “fashion” is often misused as a synonym for women’s clothing. Yet most consumer goods and services are subject to the fashion process. Fashion also affects noneconomic matters such as social customs. The economic structure of consumer goods industries reflects the role of fashion, which in turn indirectly affects basic industries. Because “fashion” can involve virtually all aspects of contemporary life, this essay concentrates on the economics of clothing.

cient Mesopotamia, the need to record exchanges of these and other goods stimulated development of counting systems and writing. Eventually, coinage evolved to expedite transactions. Still later, Italians pioneered bookkeeping, banking, and legal systems to facilitate and organize international commerce.

The great plague, the Black Death, which killed as many as one-third of the people in Europe, may have reached Europe from Asia in the middle 1300s, transported by infected fleas on furs carried by caravans along the ancient silk road. As the plague abated, fashion change accelerated because of greater concentration of population in cities, shifts in the distribution of wealth, and growing importance of commercial life. The demand for furs in the sixteenth century, including beaver skins to make fine felt hats, became a major force driving the exploration of North America. Remote Australia and New Zealand were settled largely because sheep could be raised profitably there.

### Guilds

In the Middle Ages and Renaissance, members of guilds produced elegant and costly clothing to order for wealthy and high-ranking people on the European continent. Guilds were part civic associations, part trade associations, part labor unions. Guilds specialized in certain crafts ranging from hats to shoes. Membership was strictly controlled; new members served long apprenticeships and had to meet strict criteria for admission. Detailed rules served to uphold quality of production and limit competition. In general, men dominated the guilds; women did certain specialized tasks such as embroidery but had little role in governance. Not until the late 1600s, as guilds were ebbing in power, was the first guild controlled by women, the mantua makers, officially recognized in France.

### National Pride and Profit

Nations have long promoted fashions to stimulate demand for their products. In the 1600s, King Louis XIV displayed the beauty of French silks and laces by wearing them and dictating that members of the French nobility also showcase French products. France sent dolls dressed in the latest fashions to other nations to create desire for French goods among the upper classes. According to Mr. Pepys’ diary, Charles II of England introduced a subdued style of men’s clothing in England in 1666, partly to promote English wool and linen fabrics.

### The Origin of Ready-to-Wear

During the reign of Charles II, according to Beverly Lemire, the ready-to-wear clothing industry originated when shipowners or the British navy ordered plain, coarse garments in quantity to outfit crews of English ships heading to sea on voyages lasting months or years. There were as yet no garment or textile factories in the modern sense. Garment production was controlled by (mostly) men who contracted with the government or shipping companies, bought materials in quantity and then hired workers who



“Demand” is not a quantity; it is the relationship between prices and how much consumers are willing to buy at various prices. If demand for a commodity is great, people will generally buy larger amounts of it at various prices than they will buy if demand is small.

took the supplies home with them to make the garments by hand. Workers were paid by the unit, and the contractors often cheated them. The system of subcontracting clothing production continues today.

### **Mechanization of Production**

Although production of ready-to-wear clothing began before sewing machines existed, an English clergyman had invented a hand-operated knitting frame near the end of the sixteenth century. Queen Elizabeth I refused to grant him a patent because she feared it would put English hand-knitters, using knitting needles and mostly working at home for contractors, out of work. But by the eighteenth century, England led the industrial revolution with a stream of inventions that eventually reduced prices of many goods and improved their quality so that ordinary people could afford them. By the later 1700s, English factories were turning out fabric on water- or steam-powered spinning and weaving equipment. Demand for inexpensive clothing gradually increased in England as lower-class people, some of them employed in the new factories, began to have a bit more money to spend, as well as a growing interest in fashionable clothing. London stores began to display appealing merchandise in lighted shop windows and encouraged shopping as recreation. Even low-income people could buy small ribbon ornaments and other accessories (See McKendrick, Brewer, and Plumb).

Meanwhile, clothing styles of English noblemen became simpler and more functional as they supervised agricultural activities on their estates rather than hanging around the royal court, as was the case in France. French noblemen copied English styles when the French Revolution made it dangerous to be seen in public wearing silks and laces.

By the early nineteenth century, workingmen's clothing was being cut and hand-sewn by workers who specialized in specific tasks rather than each making a garment from start to finish. In American coastal cities, workers constructed garments for sailors in lofts where sails were made, from the same sturdy materials. Inventors designed the first sewing machines, but handworkers, who feared losing their jobs, broke up the machines, which didn't work very well anyway. Improved versions soon followed; the 1800s brought numerous apparel-related inventions and discoveries, including shoemaking machinery, vulcanized rubber, artificial cellulosic fibers, and synthetic coal-tar dyes.

Wars such as the American Civil War created demand for large quantities of uniforms. Based on measurements of servicemen, standardized sizing of men's clothing evolved. By the later 1800s, men's factory-made clothing of reasonably good quality and fit was being produced in quantity. Although wealthy men still wore custom-made clothing, moderate-income men could dress better than ever before.

The situation for women's clothing differed from that for men's clothing. Styles were relatively simple in the later 1700s and early 1800s, but then outfits became increasingly ornate and complex and remained so for the rest of the nineteenth century. This complexity, plus lack of measurement data for women, delayed large-scale factory production of women's clothing. Late in the century, when separates—shirtwaist and skirt styles and tailored women's suits—became fashionable, it was easier for women to find ready-made clothing to fit. By the end of the 1800s, output of women's factory-made clothing was growing rapidly.

### **Paris Couture**

Although wealthy people still wore custom-made clothing in the 1800s, the guilds were gone by the time Charles Worth, ironically an English immigrant to Paris, opened the first couture house in the mid-nineteenth century. The Paris couture, offering exclusive new styles for women to be made-to-order each season, reached its peak volume in the late 1800s and early 1900s. Only the richest women could afford couture apparel, and volume was never large, but the couturiers were masters of publicity. Actually, the practice of holding well-publicized "showings" of new fashions each season originated in England not with clothing designers but with such enterprising businessmen as Josiah Wedgwood, who in the late eighteenth century invited well-to-do customers to seasonal openings of his latest designs in tableware and decorative ceramics (See McKendrick, Brewer, and Plumb).

### **Fashion for Everyone**

With the help of fashion magazines, which originated in the early 1800s, and paper dress patterns for home sewers, introduced later in the century, seamstresses copied or adapted couture designs for middle-class clientele far from fashion centers. In America, some dressmakers traveled from household to household twice a year, spending a couple of weeks making new clothes for all females in a family. Electric-powered sewing machines were installed in factories, but home sewers and dressmakers used machines with foot treadles so they were not dependent on electricity.

The first department stores opened in major cities in the United States and Europe in the mid-1800s, with clothing as a major category of merchandise. Instead of bargaining with customers over selling prices, as small shopkeepers did, department stores began putting price tags on their goods. Retail magnates such as B. Altman, John Wanamaker, and Marshall Field built palatial stores to dramatize shopping as recreation. Streetcar transportation, first horse-drawn and later electric-powered, brought customers downtown. Smaller stores specializing in men's or women's apparel, children's clothing, undergarments and lingerie, or shoes, profited from customer traffic attracted to city centers by big stores.

Catalog order firms such as Sears, Roebuck originated in the 1800s as postal service and railroads developed in the United States. Mail order made ready-to-wear clothing available to rural and small-town residents. The first outlying shopping centers opened in the second and third decades of the twentieth century, as automobiles multiplied; Sears, Roebuck opened its first retail store in an early shopping center. After World War II, building of suburban branches of large department stores and major regional shopping centers accelerated, leading to the decline of downtown shopping and the closing of many central city stores. Giant regional shopping centers capitalized on the entertainment aspect of shopping and consumers' seemingly limitless appetite for variety.

### Competition for Consumers' Money

Accelerating competitive trends in the apparel business has been the gradual decline of clothing's share of total consumer spending. What limited records survive show that during the Middle Ages and Renaissance in Europe, in the heyday of the guilds, rich people spent huge proportions of their incomes on luxurious clothing for themselves. Furthermore, the nobility outfitted the various ranks in their households, even down to the lowest servant, in appropriate styles and the manor's heraldic colors for specific festivals or occasions.

Once, there were only limited ways to spend money to demonstrate one's wealth—what Thorstein Veblen named "conspicuous consumption." In the past 150 years, factory production has made clothing for ordinary people less expensive, while many appealing new products have become available: phonographs and parlor pianos, household appliances—including sewing machines—motor vehicles, and electronic goods, starting with telephones and radios. All of these impressed people's friends and rivals, competing with clothing for the consumer's money. Of every twenty dollars Americans now spend, only about one goes for clothing. Simultaneously, long-term fashion trends, dating back at least to Charles II of England in the 1600s, have moved toward ever-simpler, less-formal, more casual clothing even for people in the upper ranks of society. As more women work outside the home, fewer of them dress to showcase their husbands' wealth and prosperity, as they might have in Veblen's world. Demand for men's tailored clothing declined in the later twentieth century, as did the number of specialty stores selling men's clothing, as men chose more casual clothing and active sportswear.

### Growing Ferocity of Competition

Couture was not profitable after World War I; its client base dwindled further during the Depression of the 1930s. Designers tried to control copying of their designs and sometimes produced lower-priced replicas of their own exclusive models. Design piracy has long been a plague for clothing manufacturers and designers, but no tactics seem to stop it, especially when consumers are ea-

ger for the latest fashions at the lowest possible prices. The spending of fickle teenaged customers, anxious to look like popular entertainers, accelerates the pace of fashion change.

For a time after World War II, couture houses licensed their names to other firms to produce lower-priced clothing merchandise and accessories. Some ventured into men's wear, with limited success. In Europe and North America, the number of establishments producing fine custom-made clothing and the number of customers that bought it had declined. Demand continues to shrink for complex and costly custom-made apparel such as elaborately embroidered or beaded garments. To the extent that such clothing is still produced, production moves to India and other Asian countries.

By the late twentieth century, large European corporations, some outside the apparel business, competed to buy Paris couture houses and leading Italian design firms, while other high-end design houses gobbled up each other. Sales of expensive apparel and luxury accessories to wealthy people and entertainers all over the world burgeoned in the 1990s' economic boom. Designer-name firms outdid each other by opening showy retail stores, designed by avant-garde architects, in major cities around the world, but some of these stores attracted more lookers than purchasers and soon closed. Young design-school graduates from England, Belgium, New York, California, and elsewhere started their own small firms; only a lucky few achieved enough recognition or financial backing to stay in business.

### A Low-Paid Workforce

Clothing workers have always been poorly paid. Clothing for serfs and servants on medieval estates was produced on-site, usually from materials grown, harvested, and processed by serfs—essentially, slave labor. Slaves made their own clothing on American cotton plantations. Clothing production prospers where cheap labor is plentiful. Although some operations require great skill, most construction tasks are divided into small steps that can be learned quickly. In the past 200 years, garment factories have been among the first large-scale manufacturing enterprises to open in developing nations. In nineteenth-century New York, manufacturers crowded hundreds of poorly paid immigrants into high-rise buildings, often in unsafe situations. Contracting and homework were widespread. One group of immigrants after another supplied the labor—German, Irish, Jewish, Italian; in the twentieth century, Puerto Ricans, Chinese, and Blacks joined the list. Even today, "sweatshops" owned by and employing immigrants from Asia flourish in New York City. During the second half of the twentieth century, garment manufacture spread to Hong Kong, then to China and other parts of southeast Asia, not to mention Latin America and African locations that have large numbers of people willing to work for low wages. Although machines facilitate clothing construc-



tion, much of the process resists automation. Reading clothing labels is a lesson in geography.

### Factoring

A longtime practice in the fashion industry is “factoring,” whereby a company takes out short-term loans to buy fabrics and other materials to produce garments for the season, then repays the loans as retailers purchase the goods. The specialized lenders are called “factors.” Factoring is not limited to apparel production; it also exists in other industries where fashion changes quickly, such as toys. A plague of the fashion business is that retailers squeeze manufacturers by returning unsold goods or paying less than the agreed-upon price. Because the garment business is so competitive, profits are low and existence is risky.

### The Used Clothing Trade

Trade in secondhand clothing has been important for many centuries. Once wealthy and high-ranking people gave their unwanted clothing to servants. Usually, servants sold the garments—they had no use for them and needed the money. Patrons of theatres such as Shakespeare’s Globe donated clothing to actors who could not otherwise afford credible costumes when playing high-ranking characters. Used clothing, including stolen items, was sold by peddlers alongside crude, early ready-to-wear. In the nineteenth century, the first factory-made garments were sometimes introduced by secondhand clothing retailers. Stores selling both used and new clothing (including military surplus) existed until after World War II. Postwar, “yard” and “garage” sales became common, apparently inspired by such sales on military bases, especially when officers’ families had to move to totally different climate zones. Consignment shops, operated by charitable organizations or private entrepreneurs, multiplied.

As the quantity of discarded clothing in Europe and North America exceeded the capacity of welfare agencies to distribute it to the poor, large quantities of used clothing have been shipped to developing nations. In Africa, inexpensive used clothing can displace traditional apparel and compete with local industries. At the other extreme, “vintage” clothing—used couture or high-fashion women’s clothing—has become so popular and acceptable that leading Hollywood actresses may wear old designer gowns to the Academy Awards ceremonies. Exclusive auction houses sell vintage designer clothing for high prices; retail stores in New York and Los Angeles specialize in such clothing.

### Continuing Change

The garment business consists of all sizes of firms from giant to tiny. Although the trend is giant companies, these are not assured of success. Large corporations manufacture clothing under many labels. Some famous brand names produce different qualities of clothing for different types of retailers, contracting out production of some merchandise lines to other corporations. Major producers can go bankrupt unexpectedly; failure lurks just

around the corner due to shifting customer tastes and a variety of other uncertainties. International trade regulations, tariffs, and quota systems engage the services of a corps of lawyers and other specialists.

Everything changes quickly in the apparel world. Cities of developed nations are littered with abandoned factories, empty retail stores, defunct design houses, and wreckage of supporting industries. Once-famous department stores are now history; Montgomery Ward is nearly forgotten; Sears Roebuck slips in importance. Someday Wal-Mart may fade away. As more shopping centers and big-box stores open, downtowns and old shopping centers die. Everyone in the business knows that there is too much retail space, yet they keep building stores. Change is the only certainty.

The next phase in clothing distribution may be the Web, whether goods are sold by conventional retail stores, catalog retailers, Web-based retailers, or something completely different. Auction sites such as eBay offer vintage clothing and also help manufacturers and retailers trade large quantities of materials and clothing among themselves.

*See also* **Department Store; Fashion Industry; Globalization; Labor Unions; Mantua; Ready-to-Wear; Retailing; Secondhand Clothes, Anthropology of; Secondhand Clothes, History of; Sewing Machine; Sweatshops.**

### BIBLIOGRAPHY

- Benson, Susan Porter. *Counter Cultures: Saleswomen, Managers, and Customers in American Department Stores, 1890–1940*. Champaign: University of Illinois Press, 1988.
- Cobrin, Harry A. *The Men’s Clothing Industry: Colonial Through Modern Times*. New York: Fairchild Publications, 1970.
- Cooper, Grace Rogers. *The Sewing Machine: Its Invention and Development*, 2nd ed. Washington, D.C.: Smithsonian Press for the National Museum of History and Technology, 1976.
- Cray, Ed. *Levi’s*. Boston: Houghton Mifflin, 1978.
- Danish, Max D. *The World of David Dubinsky*. Cleveland: The World Publishing Co., 1957.
- DeMarly, Diana. *The History of Haute Couture, 1850–1950*. New York: Holmes & Meier, 1980.
- Frick, Carole Collier. *Dressing Renaissance Florence—Families, Fortunes, and Fine Clothing*. Baltimore: Johns Hopkins University Press, 2002.
- Hansen, Karen Tranberg. *Sahula: The World of Secondhand Clothing and Zambia*. Chicago: University of Chicago Press, 2000.
- Helfgott, Roy B. “Women’s and Children’s Apparel.” In *Made in New York: Case Studies in Metropolitan Manufacturing*. Edited by Max Hall. Cambridge: Harvard University Press, 1959.
- Hendrickson, Robert. *The Grand Emporiums*. New York: Stein and Day, 1979.
- Kirke, Betty. *Madeleine Vionnet*. San Francisco: Chronicle Books, 1998.
- Lemire, Beverly. *Dress, Culture and Commerce: The English Clothing Trade Before the Factory, 1660–1800*. New York: St. Martin’s Press, 1997.

- Lockwood, Lisa. "Mega-Merger Mania: The New Blueprints of Five Ravenous Firms." *WWD* 186, no. 36 (2003): 1, 6–7.
- McKendrick, Neil, John Brewer, and J. H. Plumb. *The Birth of a Consumer Society: The Commercialization of Eighteenth-Century England*. Bloomington: Indiana University Press, 1982.
- Nystrom, Paul H. *Economics of Fashion*. New York: The Ronald Press Company, 1928.
- Rexford, Nancy E. *Women's Shoes in America, 1795–1930*. Kent, Ohio: Kent State University Press, 2000.
- Sanders, N. K. *Prehistoric Art in Europe*, 2nd ed. New York: Viking Penguin, 1985, pp. 49–50.
- Spufford, Peter. *Power and Profit: The Merchant in Medieval Europe*. New York: Thames & Hudson, Inc., 2003.
- Veblen, Thorstein. *The Theory of the Leisure Class*. New York: Macmillan, 1899. Reprint, New York: The Modern Library, 1934.
- Walker, Richard. *Savile Row: An Illustrated History*. New York: Rizzoli International, 1989.
- Winakor, Geitel. "The Decline in Expenditures for Clothing Relative to Total Consumer Spending, 1929–1986." *Home Economics Research Journal* 17 (1989): 195–215.

Geitel Winakor

**EGYPTIAN COTTON.** See **Cotton**.

**ELASTOMERS** When most textile fibers are stretched more than around 10 percent of their length, they may recover a little of this distortion rapidly, some more slowly, but some permanent distortion remains. In contrast, an elastomeric fiber will typically recover rapidly and completely from elongations of 100 percent or more. They provide textiles with greater stretchiness and recovery than is possible by the use of texturized yarns and knitted structures and are used in waistbands, sock tops, foundation garments, and exercise wear.

The prototype elastomeric fiber is rubber. Natural rubber latex can be coagulated in many forms (balloons and rubber gloves, for example) and also in the form of fibers, although it is not possible to produce rubber as fine as most other textile fibers. Rubber fibers are difficult to dye, so when incorporated into a fabric that is stretched, the white rubber is visible. For that reason, most rubber is covered by another fiber spun or wrapped around it, such as cotton, which can be dyed. Fabrics containing covered rubber yarns are used in waistbands, sock tops, and foundation garments. Natural rubber is cheap, but suffers from degradation by chlorine bleach, and in the longer term by body oils, atmospheric contaminants, and metal salts.

Occasional shortages of natural rubber have led to a search for synthetic alternatives, and fibers have been produced from many synthetic rubbers. Anidex and Lustrile are two generic names assigned to such elastomeric fibers, although these are now obsolete.

Spandex dominates the synthetic elastomeric fiber market in the early 2000s. Originally developed by DuPont as "Lycra," it is produced by many manufacturers around the world. Chemically, spandex is a polyurethane, and in Europe such fibers have been simply called polyurethane, but more often are referred to as "elastane."

Spandex is a comparatively weak fiber (it has a tenacity of around 0.7g/d) but since it will stretch 3 to 7 times its length before breaking, its lack of strength is not cause for concern. It can be produced as fine as most other manufactured fibers, and it is dyeable. It can be incorporated directly into fabrics (knitted or laid in to knits), or like rubber, it may be covered or core spun with another fiber for weaving. Depending on the end use, spandex may comprise 2 to 20 percent of a blend. It shares many of rubber's end uses and is also incorporated in less-specialized fabrics such as those used for swimsuits, exercise wear, and regular fashion apparel. In low percentages, it improves the recovery of worsted and denim fabrics. Its dyeing properties are similar to those of nylon, and it is commonly found in blends with that fiber. Blends with polyester are cheaper, but the high temperatures useful for dyeing polyester are damaging to polyurethanes, and such blends are less common than expected. While spandex is less susceptible to chlorine than rubber, it is still damaged by chlorine: polyester-based spandex fibers are less prone than the polyether-based versions. It melts at around 450°F and one of its few drawbacks is a relatively high cost.

Research into new elastomeric fibers continues. Recently, Dow has introduced a metallocene-based, cross-linked olefin elastomeric fiber, Dow XLA, that has been given the generic name "lastol." It is heat resistant, and maintains its stretch properties through processes such as dyeing and finishing, although the fiber itself is not dyeable. The FTC has also given the generic name "elasterell-p" to DuPont's fiber T400. Elasterell-p is based on a combination of polyester polymers.

See also **Dyeing; Fibers**.

#### BIBLIOGRAPHY

- Adnaur, Sabit. *Wellington Sears Handbook of Industrial Textiles*. Lancaster, Pa.: Technomic, 1995.
- Cook, J. Gordon. *Handbook of Textile Fibers. II: Man-Made Fibers*, 5th ed. Durham, U.K.: Merrow, 1984.
- Moncrieff, R. W. *Man-Made Fibres*. 6th ed. London: Newnes-Butterworth, 1975.

Martin Bide

**ELLIS, PERRY** Perry Ellis (1940–1986) was regarded as an outstanding designer of American sportswear in the 1970s and 1980s. In order to appreciate the far-reaching allure of his best-known invention, a deceptively simple homemade-looking sweater, one should understand the



**Model in Perry Ellis design.** Perry Ellis launched his sportswear collection in 1978, garnering instant acclaim for his concept of separates that could be mixed and matched. © REUTERS NEW-MEDIA, INC./CORBIS. REPRODUCED BY PERMISSION.

potent appeal that American sportswear held in the 1970s. Separates dressing at that time meant individual style—a radically new approach after more than a century of one dominant silhouette following another. And individual style was particularly relevant at a time when gender roles were being tossed in the air. What Perry Ellis did best was take elements of classic American style—stadium coats, tweed jackets, and culottes—and adapt them to suit changing times.

Perry Ellis was born on 3 March 1940. He grew up in Churchland, a small suburb of the Virginia coastal town of Portsmouth. Ellis earned a B.A. in business from the College of William and Mary, and went on to acquire a master's degree in retailing from New York University. He then went to work in Richmond at Miller and Rhoads, a Virginia department store that was similar in size and quality to such New York emporia as B. Altman or Bonwit Teller. During Ellis's tenure with Miller and Rhoads, his department, junior sportswear, had the highest sales in the store.

At Miller and Rhoads, Ellis worked closely with manufacturers, making design suggestions as he saw fit. His suggestions sold well, leading a favorite supplier, John Meyer of Norwich, to offer Ellis a job in 1968 as design director. This firm's preppy style was aimed at high school and college students, offering coordinated ensembles of cotton print blouses with Peter Pan collars, cable-knit cardigans, and corduroy skirts. In 1974 Ellis moved to Manhattan Industries, where he became vice president and merchandising manager for Vera Sportswear. Vera Neumann was an artist whose popular scarves and outfits were based on her signed paintings. Ellis was intrigued by the challenge of working with her designs, and came up with styles that attracted considerable positive attention in the fashion press. In 1975 he debuted his own line for Manhattan Industries, which was known as Perry Ellis for Portfolio. He then launched his own label, Perry Ellis Sportswear, in 1978. Acclaim was instant. A menswear line and various licensing arrangements soon followed, as did a number of professional honors. After winning two Coty awards each for women's wear and men's wear, Ellis was voted into the Coty Hall of Fame in 1981. He also received awards from the Council of Fashion Designers of America (CFDA) for women's wear in 1981 and men's wear in 1982.

The launch of Perry Ellis Sportswear for the fall-winter season of 1978 was memorable. The show opened with a group of Princeton University cheerleaders wearing little pleated skirts and sweaters emblazoned with a large "P." This collection firmly established what became the signature Perry Ellis look—what he coined the slouch look. It consisted of separates based on pieces that could work in different combinations: oversized jackets, thick yarn sweaters, lots of layers, ribbed socks worn rumpled like leg warmers, men's Oxford shoes for women. While the riffs on scale and silhouette were sophisticated, the casual fabrics seemed fresh. Although the references



might have been collegiate, these were clothes for adults who were confident enough to thumb their noses at the rigid styles associated with dressing for success.

Further notable collections followed. The fall 1981 collection featured a mix of challis prints in deep jewel tones with duck and pheasant motifs, with all scales of prints and colors worn together in a single ensemble. Ellis's spring 1982 collection coincided with the release of the film *Chariots of Fire*, and featured relaxed flapper lines in pale linens. The fall–winter 1984 collection was an homage to French painter Sonia Delauney—bold geometric patterns in deep rich colors for men and women.

Much has been made of Ellis's perfectionism. What seemed mandatory for the visually oriented person in the early twenty-first century, such as insisting on a specific look for everything from the company's logo and store interiors to bouquets of flowers sent to fashion editors and the postage stamps used on invitations to shows, was noteworthy in the late 1970s for a Seventh Avenue designer—especially one working in the less glamorous area of sportswear. Ellis's perfectionism extended to every part of his collection; the models' hair and makeup had to look natural, and nail polish was forbidden. Manolo Blahnik designed shoes for Perry Ellis, usually ghillies, ankle boots, or spectator pumps in an Edwardian or prairie mood. Patricia Underwood designed strikingly simple hats, and Barry Kieselstein-Cord made jewelry, belts, and hair ornaments in precious metals.

At a time when fashion designers were becoming glamorous celebrities, Perry Ellis remained somewhat of an enigma. He was startlingly handsome, yet dressed in an antifashion uniform consisting of khaki pants, a dress shirt with the cuffs rolled up, and Topsider shoes left over from his college fraternity days. Famously shy, he exuded charisma. Although heralded as an overnight sensation, he had definitely paid his dues on the way up. A household name, he kept his personal life private. One minute he was at the top of his game, or so it seemed, and next came the shocking news of his death. After an appallingly rapid decline, witnessed silently by his staff, friends, and the fashion industry, he died of AIDS on 30 May 1986.

After Ellis's death, his long-time assistants Patricia Pastor and Jed Krascella designed for the company. The firm then hired a rising star, Marc Jacobs, in 1988. As a teenager, Jacobs had asked Perry Ellis for career advice, and was told to go to Parsons School of Design, where he won the Perry Ellis Golden Thimble Award in 1984.

At first Perry Ellis and Marc Jacobs seemed like a good combination. Jacobs's stretch gingham frocks, cheerful colors, and prints suited the mood of the firm and the late 1980s. Then came the infamous grunge collection, shown in 1993, which appalled the press and potential buyers alike. However, like most controversial fashions, the grunge look of layered vintage military surplus pieces was merely ahead of its time. After Jacobs left the company, Perry Ellis International decided against

having a star designer, choosing for a time to have a team of people developing the brand. In 2003 Patrick Robinson was hired as designer. His fall–winter 2004 collection, based in part on a vintage Perry Ellis scarf found for sale on an Internet site, received good reviews. A particularly American touch from Robinson's spring 2004 collection—the models wore Converse sneakers—paid homage to both Perry Ellis and Marc Jacobs.

See also **Blahnik, Manolo; Dress for Success; Grunge; Seventh Avenue; Sportswear.**

#### BIBLIOGRAPHY

- Brubach, Holly. "Camelot." *New Yorker* (25 July 1988): 83–86.
- Diamonstein-Spielvogel, Barbaralee. *Fashion: The Inside Story*. New York: Rizzoli International, 1985.
- Milbank, Caroline Rennolds. *New York Fashion: The Evolution of American Style*. New York: Harry N. Abrams, Inc., 1989.
- Moor, Jonathan. *Perry Ellis: A Biography*. New York: St. Martin's Press, 1988.

*Caroline Rennolds Milbank*

**EMBROIDERY** Embroidery is an ancient form of needlework that has been used worldwide to embellish textiles for decorative and communicative purposes. In terms of form and aesthetics, embroidery may add color, texture, richness, and dimension. Used on clothing, it may reveal the wearer's wealth, social status, ethnic identity, or systems of belief. Typically, embroidery is executed in threads of cotton, wool, silk, or linen, but may also incorporate other materials such as beads, quills, metal, shells, or feathers. Some materials, techniques, and stitches occur across many cultures, while others are specific to region.

#### Historical Overview

The origins of this art form, mentioned in the Bible and in Greek mythology, are lost. Textile scholar Lanto Syngé posits that it probably originated in China, and documents early surviving fragments that are estimated as being 4,500 years old. In South America embroideries from the fifth century B.C.E. have been recovered from tombs.

Throughout the history of embroidery, religious institutions have been among its greatest patrons. For example, the Medieval church in Europe fostered one of the greatest peaks in needlework history—*Opus Anglicanum* (English work). A type of needlework made in England during the Middle Ages, it was widely exported throughout Europe. Worked by highly skilled professionals in embroidery workshops, *Opus Anglicanum* was known for its artistry of ecclesiastical vestments. The sophisticated embroideries, made with the finest linens and velvets, were worked with silk threads in a split-stitch technique and also utilized an underside couching technique to secure the decorative gold and silver threads. Couching is an embroidery technique in which threads

are laid in a design on the surface of a base fabric and sewn to the fabric with small stitches that cross over the design threads. The religious designs were well conceived and executed in a form of needlepainting, or *acupictura*. Figures of the Virgin Mary and the saints as well as religious scenes were executed in flowing circles and geometric patterns.

*Opus Anglicanum* illustrates the potential of embroidery as a conveyor of narrative and of ecclesiastical power; simultaneously, the courts of Europe applied embroidery to secular dress whose lavish decoration served to display secular power and prestige. During the Medieval period, the production and consumption of embroidery became increasingly codified. Guilds regulated the training of professional embroiderers, while sumptuary laws attempted to restrict the wearing of embroidered garments to specific socioeconomic classes. Renaissance court costume was often elaborately embroidered with floral imagery. Inventories of Queen Elizabeth I's wardrobe list gowns embroidered with roses, oak leaves, and pomegranates. As with *Opus Anglicanum*, metal thread work was employed to connote the prestige of the subject—in this case human rather than divine.

For centuries, European court dress was often lavishly embroidered as a signifier of status. Catherine of Aragon, arriving in England in 1501 with embroidered blackwork as part of her trousseau, is credited with encouraging the use of Spanish-style embroidery, rich in blackwork. Blackwork, which originated in the thirteenth and fourteenth centuries in Islamic Egypt, is a type of embroidery stitched in monochrome on white or natural linen. Traditionally worked in black, it was also worked in red, blue, and dark green and often enriched with gold and silver threads. Geometric and scrolling patterns are executed in backstitch or double-running stitch, a reversible stitch used for edgings of collars and cuffs that could be seen on both sides. Little of this dress survives because it was worn out or recycled. It is through inventories and portraiture that much information about historic costume is gleaned. In portraits of Henry VIII and the royal family, Hans Holbein the Younger (1497–1543) so clearly defines the stitching technique used in their elaborate costumes that the double-running stitch is also known as the Holbein stitch. Eighteenth-century portraiture again reveals much about the elegance and refinement of embroidery on high society dress.

As has been the case across many time periods and cultures, embroidery was practiced in different settings, and by different levels of society. Both men and women worked in professional workshops, while women embroidered at home for domestic use and recreation. Additionally, producing embroidery at home for sale has been a means of economic sustenance for women in many cultures, as the following case illustrates.

Many countries have traditions of whitework embroidery, executed with white thread on a white ground.

*Hardanger*—a counted thread technique originating in the west of Norway and brought by emigrants to the United States—Madeira cutwork, Dresden whitework, and Isfahani whitework are a few examples. In terms of application to dress, some of the most widely consumed whitework was produced in Scotland and Ireland in the eighteenth and nineteenth centuries. The example of Ayrshire whitework provides a fascinating insight into the interaction of professional designers, workshops, individual women, and commercial and philanthropic interests within the fashion system.

This intricate whitework was characterized by floral motifs worked with fine cotton thread on a cotton ground, typically in satin stitch, stem stitch, and needlepoint in-filling. Labor-intensive and delicate in appearance, it was used to decorate babies' christening gowns, women's dress, and undergarments. Its production was highly organized by commercial firms and philanthropic organizations concerned with improving living standards in rural areas. A woodblock or lithograph design was printed on the cloth, which was then distributed to individual households, and executed by women and children. With agents as intermediaries, the finished cloths were sent to depots in large cities, made up into garments, and sold in Britain or exported to Europe and America. By the mid-nineteenth century, Ayrshire whitework was a significant industry, with an individual firm contracting with 20,000 to 30,000 workers.

Against this context another distinctive embroidery movement in Scotland evolved—that of the Glasgow School of the early twentieth century. Influential teachers such as Jessie Newberry and Ann Macbeth revolutionized the teaching of embroidery, stressing self-expression in design, and a more simplified approach to form, typically incorporating appliqué outlined in satin stitch.

### Embroidery and Couture

Because of its decorative potential as well as its ability to connote status, hand embroidery was from the beginning included in the battery of haute couture's specialized techniques. The lavishly time-intensive, specialized nature of the art, and the costliness of the materials, made it the ultimate signifier of luxury. Embroidery houses, employing highly talented designers and technicians, became an integral part of the couture industry. The most famous of these was the House of Lesage.

It is fitting that Charles Frederick Worth, designer of the Empress Eugenie's court clothing, was a master in the incorporation of embroidery as a status confirming (or conferring) accoutrement. An early design that won a medal at the 1855 Exposition Universelle was of bead-embroidered moire. Jeanne Lanvin typically eschewed patterned fabrics for embroidery. She was one of the first designers to exploit the use of machine embroidery, incorporating parallel line machine stitching as a decorative motif.

Designers such as Mary McFadden and Zandra Rhodes have adopted embroidery, with a particular interest in the manipulation of textiles for artistic effect. When combined with other techniques such as stenciling, batik, quilting, or handpainting, embroidery draws attention to the textile as a rich surface, rather like a canvas. In other cases designers use embroidery to float over the surface fabric. Dior was a master of this illusionary approach to embroidery, which ignores seamlines and construction, creating its own field of vision.

Ethnic embroidery inspirations have long infused couture, from Lanvin's designs of the 1920s to Yves Saint Laurent's "peasant" blouses and skirts. Other designers have mined long-established associations between embroidery and femininity; the sensuous aesthetic of Nina Ricci and Chloé is often heightened by delicate embroidery.

### World Traditions

All cultures have traditions of embroidery. Influences and cross-fertilizations can be traced across trade routes and patterns of migration. In other cases, techniques and stitches are unique to geographic area.

China has a long and rich tradition of embroidery centered on the ceremonial dress of the Imperial court. From the Tang dynasty (618–907) onward, silk ceremonial robes were heavily embroidered to communicate the status of the wearer within a strict hierarchy. Mythological creatures, birds, flowers, waves, and clouds were some of the panoply of forms used symbolically to situate the wearer, or allude to personal qualities or aspirations for longevity and good fortune.

The embroidery on eighteenth- and nineteenth-century robes reached an apogee of technical perfection. Motifs were meticulously rendered in satin stitch, chain stitch, and Chinese stitch—a form of backstitch interlaced with a second thread. Areas were intricately in-filled with tiny knots. As with Renaissance court dress in Europe and Medieval church vestments, liberal use of couched metal thread conveyed status and wealth.

Throughout the history of its production, the development of embroidery traditions has been fostered by imperial patronage. The Ottoman court in Istanbul was a major patron for embroidery. However, in the Ottoman Empire, embroidery was also highly integrated into everyday life. The court commissioned fine embroideries from workshops and professional women working at home, but the making of embroidered clothing and household items was part of most women's everyday activities. Within the Empire embroidery was an important commercial and domestic enterprise. The major Ottoman embroidery style is *dival*, in which metal threads are secured to the ground with couching threads.

Native American embroidery also has its own culturally expressive characteristics. The techniques of porcupine quillwork and beading predate European explorers to North America. Traditionally, this decorative art was

embroidered on skins, but after the arrival of Europeans and the subsequent acquisition of new materials, it was worked on cloth. All items of dress were embellished with needlework—coats, jackets, shirts, hoods, leggings, moccasins, and accessories such as medicine bags.

Of various techniques employed in quillwork embroidery, sewing was the most common method. Bone bodkins were used to accomplish these designs until the white trader brought needles to America. The stitch methods are similar to modern sewing terms used today: backstitch, couching stitch, and chain stitch.

Beading was another long-held practice of the Native Americans who initially used crude beads that they made from natural materials. Later, Europeans introduced finer quality beads known as trade beads that proved to be highly desirable to the Indian tribes in their embroideries. Beads were strung on thread and sewn onto the skin or cloth according to the pattern by either massing the beads in little rows or working them in an outline formation.

On one level, Native American embroideries communicate systems of beliefs. This too has been an important function of embroidery worldwide. One example is *shishadur*, or mirror work, practiced by the Baluchi people of western Pakistan, southern Afghanistan, and eastern Iran. Fragments of silvered glass attached to a cotton ground were believed to deflect evil. In Eastern Europe a folk belief that embroidered designs on clothing protected the wearer from harm infused the development of embroidery. Items of clothing such as dresses, blouses, skirts, aprons, shirts, vests, and jackets, as well as ecclesiastical vestments, were embellished with beautiful embroideries.

The unique appearance of Eastern European needlework comes from the precise use of materials, designs, techniques, and colors that when combined can often indicate a specific region of the country. Embroidery stitches in the straight, satin, and cross-stitch families are employed; but, for example, among the specialty stitches in Ukrainian embroidery are the *Yavoriv* stitch, a diagonal satin stitch, and the *Yavoriv* plait stitch, a variation on the cross-stitch.

In the early 2000s, embroidery remained a vibrant component of dress. In a global marketplace, designers and consumers may choose from an infinite variety of world traditions. For example, mirror work was absorbed into western fashion trends of the 1970s, and has periodically resurfaced as a trend in clothing and home furnishings. Embroidery has remained a pervasive element of couture and has had an enormous influence on ready-to-wear. As sewing machines for the home sewer become increasingly sophisticated, the application of machine embroidery to home-sewn clothing has burgeoned. And, possibly as a reaction to mass-production, a thriving industry has grown around the provision of custom embroidery as a means of personalizing dress.



See also **Beads; Feathers; Sewing Machine; Spangles; Trimmings.**

## BIBLIOGRAPHY

- Embroidery*. London: The Embroiderers' Guild. An informed periodical with articles on historic, ethnographic, and contemporary embroidery, exhibition, and book reviews.
- The Essential Guide to Embroidery*. London: Murdoch Books, 2002.
- Gostelow, Mary. *Embroidery: Traditional Designs, Techniques and Patterns from All Over the World*. London: Marshall Cavendish Books Ltd., 1982. Useful for a cross-cultural perspective of embroidery.
- Harbeson, Georgiana Brown. *American Needlework: The History of Decorative Stitchery and Embroidery from the Late 16th to the 20th Century*. New York: Coward McCann, Inc., 1938.
- Krody, Sumru Belger. *Flowers of Silk and Gold; Four Centuries of Ottoman Embroidery*. London: Merrell Publishers Ltd., in association with The Textile Museum, Washington, D.C., 2000. Excellent discussion of a major embroidery tradition within its cultural context. Well-illustrated with close-up details, and glossary of stitches.
- O'Neill, Tania Diakiw. *Ukrainian Embroidery Techniques*. Mountaintop, Pa.: STO Publications, 1984.
- Parker, Rozsika. *The Subversive Stitch: Embroidery and the Making of the Feminine*. New York: Routledge, 1984. Insight into the sometimes overlooked role of women as professional embroiderers and discussion of embroidery and the construction of femininity.
- Swain, Margaret. *Scottish Embroidery: Medieval to Modern*. London: B. T. Batsford, Ltd., 1986. Useful discussion on methods of production and the role of embroidery as a commercial and domestic activity.
- Swan, Susan Burrows. *Plain and Fancy: American Women and their Needlework, 1650–1850*. Rev. ed. Austin, Tex.: Curious Works Press, 1995.
- Swift, Gay. *The Batsford Encyclopaedia of Embroidery Techniques*. London: B. T. Batsford, Ltd., 1984. A comprehensive guide to techniques and their applications to historic clothing.
- Synge, Lanto. *Art of Embroidery: History of Style and Technique*. Woodbridge, U.K.: Antique Collectors' Club, 2001.

*Lindsay Shen and Marilee DesLauriers*

**EMPIRE STYLE** In its broadest sense as a term in contemporary fashion, “empire style” (sometimes called simply “Empire” with the French pronunciation, “om-peer”) refers to a woman’s dress silhouette in which the waistline is considerably raised above the natural level, and the skirt is usually slim and columnar. The reference is to fashions of France’s First Empire, which in political terms lasted from 1804 when Napoleon Bonaparte crowned himself Emperor, to his final defeat at the Battle of Waterloo in 1815. It should be noted that the styles of this period, when referring specifically to English or American fashions or examples, may be termed “Regency” (referring to the Regency of the Prince of Wales,

1811–1820) or “Federal” (referring to the decades immediately following the American Revolution).

None of these terms, whose boundaries are defined by political milestones, accurately encompasses the time frame in which “empire style” fashions are found, which date from the late 1790s to about 1820, after which skirts widened and the waistline lowered to an extent no longer identifiable as “empire style.”

The Empire style in its purest form is characterized by: the columnar silhouette—without gathers in front, some fullness over the hips, and a concentration of gathers aligned with the 3–4” wide center back bodice panel; a raised waistline, which at its extreme could be at armpit-level, dependent on new forms of corsetry with small bust gussets, cording under the breasts, and shoulder straps to keep the bust high; soft materials, especially imported Indian white muslin (the softest, sheerest of which is called “mull”), often pre-embroidered with white cotton thread; and neoclassical influence in overall style (the silhouette imitating Classical statuary) and in accessories and trim.

Neoclassical references included sandals; bonnets, hairstyles, and headdresses copied from Greek statues and vases; and motifs found in ancient architecture and decorative arts, such as the Greek key, and oak and laurel leaves. The use of purely neoclassical references was at its peak from about 1798 to just after 1800; after that, they were succeeded by other influences.

The adoption of these references has been linked with France’s Revolution and adoption of Greek and Roman democratic and republican principles, and certainly the French consciously sought to make these connections both at the height of their Revolution, and under Napoleon, who was eager to link himself to the great Roman emperors.

Applying this political reference to America is more problematic. The extremely revealing versions of the style were seldom seen in America, where conservatism and ambivalence about letting Europe dictate American fashions ran deep. However, Americans did adopt the general look of the period, and plenty of dresses survive to testify that fashionable young women did wear the sheer white muslin style. Moreover, there is ample evidence that women of every class, even on the frontiers, had some access to information on current fashions, and usually possessed, if not for everyday use, modified versions of them.

The origins of the neoclassical influence are visible in the later eighteenth century. White linen, and later, cotton, dresses were the standard uniform for infants, toddlers, and young girls, and entered adult fashion about 1780. During the 1780s and early 1790s, women’s silhouettes gradually became slimmer, and the waistline crept up, the effect heightened by the addition of wide sashes, whose upper edge approached the level that waistlines would in another decade. After 1795, waistlines rose

dramatically and the skirt circumference was further reduced, the fullness no longer equally distributed but confined to the sides and back. By 1798, fashion plates in England and France show the form-clinging high-waisted neoclassical style, with England lagging a little behind in its adoption of the extreme of the new look.

As England and France were at war for nearly all of this period, English styles sometimes took their own direction, showing a fluctuating waistline level (which should not be taken literally, as garments from this period show remarkably little deviation from a norm) and numerous decorative details borrowed from peasant or "cottage" styles, historic references, especially medieval and "Tudor," and regional references such as Russian, Polish, German, or Spanish. Often, contemporary events inspired fashions, such as the state visit of allies in the Napoleonic wars; military uniforms also inspired trim and accessories in women's fashions during these years.

Several myths persist about the styles of this period, including the idea that the style was invented by Josephine Bonaparte to conceal her pregnancy, and that ladies of fashion dampened their petticoats to achieve the clinging-muslin effects seen in classical statues. Fashions can rarely be attributed to one person (although a hundred years earlier, a pregnancy at the French court did inspire the invention of a style) and the most cursory glance at fashions of the 1780s and 1790s shows a clear progress of internal change in fashion.

The dampened petticoat myth may have arisen from some early historians', and historical novelists', misunderstanding of some comments on the new style. Compared to the heavier fabrics and stylized body shapes (created by heavily-boned, conical-shaped corsets and side-hoops) that immediately preceded them, the new sheer muslins, worn over one slip or even, by some European ladies, a knitted, tubular body stocking, would have revealed the contours of the natural body to an extent not seen in centuries. Several contemporaries and early fashion historians wrote that women looked *as if* they had dampened their skirts. However, no evidence, including scathing denunciations of the indecent new style, as well as gleeful social satirists' commentary and caricatures, exists to document that this was ever done.

The Empire style has seen numerous revivals, although modern eyes must sometimes look closely for the reference, as it is always used in tandem with the silhouette and body shape fashionable at the time. Tea gowns of the 1880s and 1890s are sometimes described as "empire style." Reform dress often borrowed the high waist and slender skirt of the Empire period, perhaps finding the relatively simple construction notably different from the styles it rejected, the high waist providing freedom from the era's constrictive corsets. By about 1908, "empire style" dresses were a large segment of fashionable offerings. The 1930s saw another minor revival, as did the 1970s. The release in the late 1990s of several film

and television adaptations of Jane Austen's novels, all set during the Empire period, inspired another revival.

See also **Dress Reform; Maternity Dress; Tea Gown.**

#### BIBLIOGRAPHY

- Ashelford, Jane. *The Art of Dress: Clothes and Society 1500–1914*. Great Britain: The National Trust. Distributed in the United States by Harry N. Abrams, New York, 1996.
- Bourhis, Kate, ed. *The Age of Napoleon: Costume from Revolution to Empire, 1789–1815*. New York: Metropolitan Museum of Art and Harry N. Abrams, 1989.
- Cunnington, C. Willet. *English Womens' Clothing in the Nineteenth Century*. London: Faber and Faber, Ltd., 1937. Reprint, New York: Dover Publications, 1990.
- Ribeiro, Aileen. *Fashion in the French Revolution*. New York: Holmes and Meier, 1988.
- . *The Art of Dress: Fashion in England and France 1750–1820*. New Haven, Conn.: Yale University Press, 1995.

Alden O'Brien

**EQUESTRIAN COSTUME** Comfort, practicality, and protection from the elements are central qualities of riding attire, though it has always been considered stylish. Distinctive accessories marked equestrian costume from streetwear: sturdy knee-high boots with a heel and sometimes spurs for both men and women, a crop, whip or cane, gloves to spare the wearer from the chafing of leather reins, and most importantly a hat for style and later a helmet for safety. Contemporary riding dress still emphasizes comfort and protection but modern materials are used in its construction, including cotton-lycra fabrics for breeches, polystyrene-filled helmets, and Gore-Tex jackets, bringing it in line with high-technology clothing used in other sports.

#### Construction and Materials

The materials worn for riding from the mid-seventeenth to the early twentieth centuries were easily distinguished from the silks, muslins, and velvets of fashionable evening dress. Equestrian activities required sturdy and often weatherproof fabrics such as woolen broadcloth, camlet (a silk and wool or hair mixture), melton wool, and gabardine for colder weather and linen or cotton twill for summer or the tropics. In the eighteenth and early nineteenth centuries, habits were frequently adorned with gold, silver, or later woolen braiding, often imitating the frogging on Hussar or other military uniforms.

For example, in Wright of Derby's double portrait of Mr. and Mrs. Coltman exhibited in 1771, both wear stylish riding dress. Thomas Coltman's dress consists of a deep blue waistcoat trimmed with silver braid, a loosely fitting frock coat, high boots, and buckskin breeches fitted so tight that the outline of a coin is visible in his right-hand pocket. British styles of equestrian dress strongly



**Princess Anne of Great Britain in riding attire.** Women's riding trousers, such as these, were introduced during the Victorian period, and gained in popularity after riding sidesaddle fell out of fashion. In the early twenty-first century, there was little difference between riding habits for men and women.

© TIM GRAHAM/CORBIS. REPRODUCED BY PERMISSION.

influenced civilian fashions in other countries. In particular, French Anglophiles imitated British modes as early as the eighteenth century. The British frock coat became known as the *redingote* in France, a corruption of the word "riding-coat." Equestrian influence has subtly shaped men's dress to the present day, and vestiges of it remain in the single back vent of coats and suit jackets, which derive from the need to sit comfortably astride a horse and wick off the rain. Mary Coltman sits sidesaddle and wears a habit in one of the most fashionable colors for women in the eighteenth century when red, claret, and rose were in vogue. Her light waistcoat is trimmed with gold braid and she sports a jaunty plumed hat. Other portraits that feature eighteenth-century riding dress include Sir Joshua Reynolds's portrait of Lady Worsley and George Stubbs's double portrait of the Sheriff of Nottingham and his wife, Sophia Musters.

In the nineteenth century, riding dress became more subdued in style and hue for both sexes. The early

nineteenth-century gentleman wore a single-breasted tailcoat, sloping in front with a single-breasted waistcoat and cravat or stock. On horseback, he wore the same garments on his upper body but his coat might have distinctive gilt buttons. His legs required more specialized garments: breeches made from buckskin were typically worn and for "dress" riding trousers or pantaloons with a strap to keep them from riding up. If he wore shoes rather than boots, he could use knee-gaiters to protect his legs.

Because of their practicality, lack of decorative detail, and allowance for mobility, women wore riding habits not only on horseback but also as visiting, traveling, and walking costumes during the day. For women, the upper half of riding habits often differed little from the clothing worn by their male counterparts, with the addition of darts and shaping for the bust. The bottom half of the horsewoman's costume expressed her femininity. Because ladies were expected to ride sidesaddle from the fifteenth to the early twentieth centuries, they wore skirts specially designed for the purpose. This contrast between the masculine upper half and feminine lower half led one early eighteenth-century writer to call it "the Hermaphroditical." While skirts tended to be relatively simple in cut and construction and quite voluminous in the early modern period, the Victorian habit-skirt was a masterwork of tailoring. Because the skirt could catch on the saddle in the event of a fall, injuring or killing the rider, many "safety skirts" were designed and patented by British firms like Harvey Nicholl and Busvine. These asymmetrical shorter skirts took many forms, including the apron-skirt, a false front that covered the legs when mounted and could be buttoned at the back when the rider dismounted.

Emerald green habits with short spencer jackets were popular in the early decades of the nineteenth century and during the 1830s followed the fashions for leg o'-mutton sleeves. During the Victorian period, as men's dress became more somber, so did women's riding habits. This is because riding habits were made by tailors rather than dressmakers and cut and fashioned with the same techniques from the same selection of fabrics. By the end of the century, black was the most appropriate color for women's riding dress. As riding became a popular leisure activity for the middle classes, etiquette and equitation manuals aimed at those who had no experience of riding flourished, and these often included strict advice about dress. As Mrs. Power O'Donoghue wrote in *Ladies on Horseback* (1889):

A plainness, amounting even to severity, is to be preferred before any outward show. Ribbons, and coloured veils, and yellow gloves, and showy flowers are alike objectionable. A gaudy "get-up" (to make use of an expressive common-place) is highly to be condemned, and at once stamps the wearer as a person of inferior taste. Therefore avoid it.

The Victorian period introduced breeches and riding trousers for women. This garment prevented chafing



and was concealed under the skirt. Tailors and breech-makers often advertised a lady assistant to measure a woman's inseam, and the resulting breeches were made from dark wool to match the habit and remained invisible if the skirt should fly up.

Colonialism, female emancipation, and increased participation in a wide variety of sports, especially bicycling, changed women's relationship with the riding costume. On their travels, women used horses for practical transportation and exploration and these animals were not always broken to ride sidesaddle. For safety and comfort, women had to ride astride and new habits with breeches or "zouave" trousers and jackets with long skirts were devised. Jodhpurs, named after a district in Rajasthan, were based on a style of Indian trousers that ballooned over the thighs and were cut tightly below the knees. These became popular for both men and women on horseback. "Ride astride" habits began to become acceptable in the first decades of the twentieth century, though many women continued to ride sidesaddle until mid-century. A 1924 illustration in American *Vogue* shows both a more formal black sidesaddle habit worn with cutaway coat and top hat and a tweed ride-astride habit worn with jodhpurs and a floppy-brimmed hat. Tweeds were standard for informal riding wear such as "hacking jackets." In the second half of the twentieth century riding had evolved in the directions of both recreation and competitive sport and specialized clothing with higher safety standards had become the norm, and less expensive materials like rubber replaced leather boots while polar fleece, Gore-Tex, and down jackets were used for warmth and waterproofing.

Different types of equitation demanded variations in dress and etiquette. While horses were often the most practical means of transportation in the eighteenth century, the advent of rail travel increased the popularity of riding as a leisure activity. The degree of formality in dress depended on whether the activity was an informal country hack, an aristocratic foxhunt, or a ride in an urban park. The most fashionable urban sites for riding were Rotten Row in London and the Bois de Boulogne in the west of Paris.

Functional clothing worn for work with horses included the carrick or greatcoat of the coachman with triple capes to keep off rain and snow. Each equestrian profession, from the groom to the liveried postillion, had a distinctive form of dress. Those who worked in agricultural contexts around the world developed specialized attire, such as the leather or suede chaps worn by the American cowboy, the sheepskins worn by herders in the French marshes of the Camargue, or the poncho worn by gauchos in South America.

Hunting clothing was often regular riding clothing adapted for convenience and protection from the elements. In the eighteenth century some hunts adopted specific colors and emblems, though the red coat was by

no means universal and green, dark blue, and brown were popular. Red woolen frock coats or "hunting pinks" with black velvet collars were the mark of the experienced foxhunter.

Racing developed its own specialized clothing as well. In contrast with the thick and waterproof garments worn on the hunt, the jockey's clothing had to be light and streamlined, fitting the body very tightly. By the early eighteenth century, jockeys were wearing attire that is recognizable in the early-twenty-first century: tight jackets cut to the waist, white breeches, short top-boots, and peaked cap with a bow in front. At that time, the cap was black; but the bright and highly visible, often striped or checked "colored silk" livery of the jacket made the owner's identity clear. Satin weaves gave these silks their glossy sheen. Because of its sexual appeal and bright coloring, jockey suits were often copied in women's fashions by nineteenth-century couturiers like Charles Worth.

For example, in Zola's novel *Nana*, the eponymous heroine, a Parisian courtesan, goes to the races dressed in a jockey-inspired outfit:

She wore the colours of the De Vandevres stable, blue and white, intermingled in a most extraordinary costume. The little body and the tunic, in blue silk, were very tight fitting, and raised behind in an enormous puff . . . the skirt and sleeves were in white satin, as well as a sash that passed over the shoulder, and the whole was trimmed with silver braid which sparkled in the sunshine. Whilst, the more to resemble a jockey, she had placed a flat blue cap, ornamented with a feather, on the top of her chignon, from which a long switch of her golden hair hung down in the middle of her back like an enormous tail. (pp. 289–290)

### Manufacture and Retail

Because of its traditions of equestrian sport, Britain has led the Western world in making riding costumes. Men could go to their habitual tailors who specialized in sporting dress.

The fabric used for making women's habits could be very expensive and because of the amount of cloth needed, it often cost substantially more than an evening gown. Like men's suits, riding habits were expected to last several years and to stand up to intensive use. Despite its elite connotations, ready-made habits were available in the eighteenth century from mercers and haberdashers' shops, and in the nineteenth century from department stores and working-class men's clothiers and outfitting firms trying to move upmarket by advertising "ladies' habit rooms." At the upper end of the market, firms offered luxury services to their clientele. In the 1880s, British tailoring firms such as Creeds opened branches in Paris. The suites of the British women's tailor and couturier Redfern in Paris, situated on the rue de Rivoli, were celebrated as "the rendez-vous of all the

sportswomen whom the foreign and Parisian aristocracy count among their number.” Redfern proposed stuffed block horses of several colors so that his clients could choose their habits in a tone that matched the hide (*robe*) of their favorite mount. The word for the hue of a horse’s hide and woman’s dress were the same in French.

Riding attire has always symbolized grace and leisured elegance. It implied that its wearer belonged or aspired to belong to the horse-owning classes. Wearers often used it to challenge formal social mores in dress, deportment, and gender roles. Its rustic simplicity and informality connoted youth, ease, and sometimes impudence. For example, the dandy George Bryan Brummell made riding dress fashionable in the salons of Regency Britain, bringing “rural” modes into an urban setting. For horsewomen, etiquette was more stringent. Any woman who wore gaudy or overly ornate habits or who made a spectacle of herself was in danger of being branded a “pretty horsebreaker” or “fast woman” rather than a “fair equestrienne” in the Victorian period. Contemporary fashion designers continue to recycle traditional equestrian motifs and fabrics in haute couture and prêt-à-porter collections. In this context riding costume is most often used to connote country elegance and traditional elite English style.

See also **Boots; Breeches; Brummell, George (Beau); Protective Clothing.**

#### BIBLIOGRAPHY

- Arnold, Janet. “Dashing Amazons: The Development of Women’s Riding Dress, c.1500–1900.” In *Defining Dress: Dress as Object, Meaning and Identity*. Edited by Amy de la Haye and Elizabeth Wilson, 10–29. Manchester U.K.: Manchester University Press, 1999.
- Chenoune, Farid. *A History of Men’s Fashion*. Paris: Flammarion, 1993.
- Cunnington, Phillis, and A. Mansfield. *English Costume for Sports and Outdoor Recreation: From the Sixteenth to the Nineteenth Centuries*. London: Adam and Charles Black, 1969.
- David, Alison Matthews. “Elegant Amazons: Victorian Riding Habits and the Fashionable Horsewoman.” *Victorian Literature and Culture* 30, no.1 (2002): 179–210.
- O’Donoghue, Power [Nannie]. *Ladies On Horseback: Learning, Park-Riding and Hunting, With Hints Upon Costume, and Numerous Anecdotes*. London: W. H. Allen, 1889.
- Zola, Émile. *Nana*. London: Vizetelly and Company, 1884.

*Alison Matthews David*

**ETHNIC DRESS** Ethnic dress ranges from a single piece to a whole ensemble of items that identify an individual with a specific ethnic group. An ethnic group refers to people who share a cultural heritage or historical tradition, usually connected to a geographical location or a

language background; it may sometimes overlap religious or occupational groups. Ethnicity refers to the common heritage of an ethnic group. Members of an ethnic group often distinguish themselves from others by using items of dress to symbolize their ethnicity and display group solidarity. The words “ethnic” and “ethnicity” come from the Greek word *ethnos*, meaning “people.” Many anthropologists prefer to use the inclusive term “ethnic group” instead of “tribe,” because the latter is often employed as shorthand for “other people” as opposed to “us.” Sometimes the term “folk dress” is used instead of ethnic dress when discussing examples of ethnic dress in Europe and not elsewhere in the world. “Folk” and folk dress ordinarily distinguish European rural dwellers and peasants and their dress from wealthy landowners, nobility, or royalty and their apparel. Ethnic dress, however, is a neutral term that applies to distinctive cultural dress of people living anywhere in the world who share an ethnic background.

#### Ethnic Dress and Change

The readily identifiable aspect of ethnic dress arises from a garment characteristic (such as its silhouette), a garment part (such as a collar or sleeve), accessories, or a textile pattern, any of which stems from the group’s cultural heritage. Many people believe that ethnic dress does not change. In point of fact, however, change in dress does occur, because as human beings come into contact with other human beings, they borrow, exchange, and modify many cultural items, including items of dress. In addition, human beings create and conceive of new ways of making or decorating garments or accessories, and modifying their bodies. Even though changes occur and are apparent when garments and ensembles are viewed over time, many aspects of ethnic dress do remain stable, allowing them to be identifiable. In many parts of the world, ethnic dress is not worn on a daily basis; instead items are brought out for specific occasions, particularly holiday or ritual events, when a display of ethnic identity is a priority and a source of pride. When worn only in this way, ethnic dress may easily be viewed as ethnic costume, since it is not an aspect of everyday identity.

#### Ethnic Dress and Gender

Across the contemporary world as well as historically, gender differences exist in all types of dress, including ethnic dress. Thus, ethnic dress and gender become intertwined. Sometimes women retain the items of dress identified as ethnic while men wear items of dress and accessories that come from the Western world, especially in urban areas. For example, in India, many women commonly wear a sari or *salwar* and *kameez*, but many men wear trousers and a shirt or a business suit. One explanation is that those who work in industrial and professional jobs connected with or stemming from Westernized occupations begin to wear types of tailored clothing that have arisen from Europe and the Americas.

Another explanation for the continued wearing of ethnic styles is that a widely shared cultural aesthetic in dress may influence preferences for particular garments. For example, the soft lines of the sari in India, and the shapely but body-covering sarong and blouse (*kain-kebaya*) in Indonesia, reflect the cultural ideal of femininity in those countries.

### Selected Examples of Ethnic Dress

Garments and accessories for ethnic dress are fashioned from a wide variety of materials, often thought to be made by hand. In today's world, however, many are manufactured by machine. Textiles of many types are most frequently used for garments, although in some locations, people wear furs, skins, bark cloth, and other fibers. Particularly in tropical and subtropical areas in Africa, Asia, and the Pacific, examples of ethnic dress include wrapped garments, such as the wrapper, also called *lappa*, the sari, sarong, and pareo. In moderate and cold climates on all continents, tailored or preshaped clothing is cut and sewn to fit the body closely to provide warmth.

#### Asia and the Pacific

On the Asian continent, where the climate extends from tropical to Arctic, garment types range from wrapped to cut-and-sewn examples. Throughout India, women wrap six to nine yards of unstitched fabric in specific styles to fashion the wrapped garment called the sari, which is ordinarily worn with a blouse (called a *choli*). Many styles of wrapping the sari exist that distinguish different ethnic backgrounds within India. Indian men wrap from two to four yards of fabric to fashion garments called *lungi* and *dhobi* that they wear around their lower body. Among the Hill Tribes of Thailand, Hmong women wear a blouse and skirt with an elaborate silver necklace, an apron, a turban-type head covering, and wrapped leg coverings. In the steppe lands of Asia (for example, Mongolia), tailored garments of jacket and trousers are worn with caps and boots. In China, types of dress have changed over time, in relationship to contact with other peoples. Turks, Mongols, Manchus, and other peoples of China's Central Asian and northern borderlands sometimes influenced the cut and style of tailored garments in China itself. The fitted, one-piece women's garment with mandarin collar and side-slit skirt known as a cheongsam, or *qipao*, was invented in Shanghai in the 1920s as a garment that was acceptably both "Chinese" and "modern." Its use declined in the People's Republic of China after the late 1950s, but it continued to be worn in Chinese communities outside the mainland and is widely regarded as the "ethnic dress" of Chinese women. In Japan, variations of the garment known as kimono are cut and sewn, as well as wrapped. The kimono's body and sleeves are formed by stitching textiles together, but the body of the garment wraps around the human form and is secured by a sash known as the obi. The Korean ensemble called a *hanbok* includes a skirt for women and pants for men that

are cut and sewn, but the top garment, a jacket for both men and women, is called *chogori* and wraps across the breast.

In Indonesia, cloth (*kain*) is wrapped around the lower body for both women and men, and is worn with a blouse (*kebaya*) or a shirt (*baju*). Another option for clothing the lower body is the sarong, cloth sewn to make a tubular garment. (This word was borrowed by Hollywood to refer to the wrapped garment worn by Hedy Lamarr and Dorothy Lamour that also covers the breasts. Among many of the peoples of Indonesia, the latter style is regarded as highly informal, worn for example by women on their way to the bathing pool.) Bare feet or various types of sandals and slippers are worn with these garments.

On many of the islands of the Pacific, such as Samoa and Hawaii, the wrapped garment is called a pareo. The long, shapeless dress called a muumuu, or *robe mission* ("mission dress"), introduced by missionaries to clothe women who traditionally were only lightly dressed, is now widely accepted as a form of ethnic dress throughout the Pacific islands. Elaborate feathered headdresses are worn in many parts of New Guinea with few other body coverings. At the time of European arrival in Australia, Aborigine dress consisted of animal skin cloaks, belts, and headbands along with body piercings, scarification, and body paint. Tattooing various parts of the body has been common among many groups in the Pacific, such as the Maori people of New Zealand and some groups of Japanese.

Because of extensive colonization in Asia and the Pacific, Europeans influenced garments and accessories of indigenous people. In return, the colonizers were influenced by exposure to Asian types of dress and borrowed or modified Asian garments, such as the cummerbund, the pajama, and bandannas, into both everyday and formal dress, thus culturally authenticating them.

#### Africa

The African continent extends from the Mediterranean Sea to the Cape of Good Hope and from the Atlantic Ocean to the Indian Ocean, providing a wide variation in climate, temperature, and terrain. A majority of indigenous garments include wrapped textiles. Both men and women in West Africa wear wrappers that cover the lower body and a shirt or blouse on the upper body. African women's head ties also exemplify a wrapped textile. In Ghana, some men's garments wrap the body with a large rectangle of cloth pulled over one shoulder that extends to the feet, similar to the Roman toga. Many indigenous people wrap blankets and skins around their bodies in South Africa, and in East Africa ethnic groups like the Maasai and Somali wear variations of garments wrapped around the torso and over one shoulder to below the knees, exposing bare legs and sandals. Distinctive printed textiles that evolved from Dutch influence in



Indonesia are highly visible in African ethnic dress, but the patterns and motifs are now specifically African and often manufactured on the African continent. In North Africa, Islamic influence in dress exists that ties some of this region of Africa to other countries that are primarily Islamic in the Middle East with such examples as the gowns called caftan, djellaba, and *jilbab*. Tailored fashions with European influence also prevail across the continent, particularly in cosmopolitan cities, where the frequency of Africans wearing ethnic dress is particularly diminished. Many Africans have traveled elsewhere in the world, are exposed to mass media such as television, cinema, magazines, and newspapers, and also share knowledge of fashions from Europe and the Americas based on their colonial past. Schoolchildren frequently wear Western-style school uniforms. The secondhand market of clothing from Europe and America has also affected what Africans wear in many countries. Alterations change the garments into local fashions. In comparison to the higher prices of ready-made or tailor-made garments, the lower cost makes secondhand clothing highly desirable. Europeans and Americans who have visited or lived in African countries borrowed items and styles of dress that became incorporated into their wardrobes. Examples are the dashiki, the Yoruba shirt adopted by returning Peace Corps volunteers who served in West Africa during the 1960s, African women's head ties and hairstyles (such as cornrowing) worn by African American women, and children, and garments made from the striped Ghanaian textile called *kente*.

### Europe and Eurasia

Ethnic dress in Europe and Eurasia consists primarily of ensembles, often called folk dress that relate to garments generally from the eighteenth century on. Many such examples can be found in folk museums, such as the Benaki Museum in Athens or the Nordiskmuseet in Stockholm. Sometimes the distinctive aspect of ethnic dress appears minimally to be one item, such as the plaid or tartan kilt of men in Scotland or the elaborate lace headdress of women in Brittany that is known as the *coiffe*. Such items become romanticized as ethnic dress, worn for special events and holidays. A strong argument has arisen that indeed the tartan is a relatively recent invention that arose for clan distinction in Scotland. Among most European countries, from as far north as Norway and as far south as Greece, smaller geographic areas are often identified with a specific ethnic group that initially occupied the area. The members of these groups may vary their ensembles or particularly distinct dress items only minimally to set themselves apart from other groups within that country as in the examples of both Norwegian and Greek ethnic dress. The Saami (formerly known as Lapplanders) who live in northern Norway, Sweden, and Finland wear a distinctive tunic-suit, sedge-grass boots, and the "four-winds" hat with four corners that allow the storage of items. For those coming from the

ethnic backgrounds known as Czech and Slovak, a large linen shawl and a matron's cap surface as ethnic social indicators.

### The Americas

The enslaved Africans arrived with few examples of garments or their traditions remaining from their past, except for the African women's tradition of wearing a wrapped piece of cloth on her head. In the northern part of North America, the Inuit people (formerly known as Eskimo) fashioned furs to keep their bodies snugly warm from frigid winter temperatures. The many examples of indigenous people across the two continents often called Indians (also known as Native Americans or Native Peoples, depending on government policy and idiomatic expressions) had traditions that stemmed from various weaving and embroidery practices in Central and South America. Many weaving traditions continue from earlier times that first set apart the garments of indigenous people from the Spaniards and Portuguese who encroached upon their land and wore European-types of clothing. In such cases, it is tempting to call only the indigenous examples "ethnic dress," yet the Argentine gaucho ensemble that arose from the work traditions of Argentinean cowboys can equally be called ethnic.

*See also* **Caftan; Clothing, Costume, and Dress; Dashiki; Jilbab; Kente; Qipao; Sari; Sarong.**

### BIBLIOGRAPHY

- Baizerman, S., J. B. Eicher, and C. Cerny. "Eurocentrism in the Study of Ethnic Dress." *Dress* 20 (1993): 19–32.
- Barnes, R., and J. B. Eicher, eds. *Dress and Gender: Making and Meaning in Cultural Context*. Oxford and Providence, R.I.: Berg, 1992.
- Boulanger, C. *Saris: An Illustrated Guide to the Indian Art of Draping*. New York: Shakti Press, 1997.
- Chapman, Malcolm. "Freezing the Frame: Dress and Ethnicity in Brittany and Gaelic Scotland." In *Dress and Ethnicity: Change across Space and Time*. Edited by J. B. Eicher. Oxford and Washington, D.C.: Berg, 1995.
- Eicher, J. B., ed. *Dress and Ethnicity: Change across Space and Time*. Oxford and Washington, D.C.: Berg, 1995.
- Hansen, Karen Tranberg. *The World of Secondhand Clothing and Zambia*. Chicago: University of Chicago Press, 2000.
- Hobsbawn, E., and T. Ranger, eds. *The Invention of Tradition*. Cambridge, U.K.: Cambridge University Press, 1983.
- Kennet, F. *World Dress*. New York: Checkmark Books, 1995.
- Tarlo, E. *Clothing Matters: Dress and Identity in India*. Chicago: University of Chicago Press, 1996.
- Van der Plas, Els, and Marlous Willemsen, eds. *The Art of African Fashion*. Trenton, N.J., and Asmara, Eritrea: Africa World Press, 1998.
- Welters, L., ed. *Folk Dress in Europe and Anatolia*. Oxford and New York: Berg, 1999.

*Joanne B. Eicher*

**ETHNIC STYLE IN FASHION** During the 1990s and the first years of the new millennium, ethnic style has been one of the strongest influences in fashion. Designers such as Christian Lacroix, Dries van Noten, John Galiano, Kenzo, Vivienne Tam, Yeohlee and many others have taken their inspiration from a variety of Asian, African, Arctic, Native American and several other dress forms and aesthetic styles and created colorful, syncretic styles evocative of the past or faraway lands. They have also found sources for ethnic fashion within the West, for example in the folk traditions of Northern and Eastern Europe. The fantasy element is strong in ethnic fashion; even when based on detailed research, designs are typically given a twist so they appear contemporary.

For many Western designers, non-Western aesthetics have provided a fertile subject matter, which has enabled them to develop creatively. This ability to break conventions is associated with a way of seeing, rather than faithful adherence to any particular ethnic style. The overall eclecticism of ethnic fashion is expressed, for example, by Dries van Noten, as noted in *Touchez d'exotisme, xiv<sup>e</sup>–xx<sup>e</sup> siècles*:

For me, exoticism is the elsewhere, the other, the difference. It is generally associated with distant countries. But for me, it is rather everything that reroutes us from the ordinary . . . from our habits, our certainties and from the everyday to plunge us into a world that is amazing, hospitable and warm. (p. 203)

Fashion theory has been informed by the distinction between fashion—modern, changeable, and emanating from Western urban centers—and ethnic clothing—stable, oriented toward tradition, and belonging in the periphery. This distinction has not always been precise; however, it has had a profound influence on how society thinks about fashion. Many accounts of ethnic fashion thus tend to overemphasize the original reworking of exotic designs on the part of Western creators, just as they exaggerate the fixity of non-Western dress. In this respect, the ongoing impact of ethnic styles on Western fashion has been marginalized.

Historically, luxury has been associated with foreign origins. It is therefore impossible to date the starting point of ethnic style in Western consumption modes; in ancient times, novel and sumptuous goods arrived through trade routes from Persia, Egypt, and Central Asia, and later from India, China, Japan, Colombia, Mexico, and elsewhere. Designs and production methods of these imports were imitated, and whole industries—such as Italian and French silk production—were founded to cater for what had initially been a demand for exoticism. The taste for the foreign was also evident in the initial popularity of the cashmere shawl as a fashion item among European and American women from 1800 to 1870. Materials such as silk and cashmere are now fully naturalized in Western fashion, but from time to time their foreign origins are rearticulated in the context of ethnic fashion, for example in the recent trend for *luxe povera*.

Looking at clothes design in a stricter sense, ethnic styles were an important element in the intense experimentation with female dress in the first decades of the twentieth century. Paul Poiret adapted the lines and silhouette of the Japanese kimono to contemporary dresses, and a few years later, he picked Middle Eastern inspiration to a sultan-and-harem mode of loose garments and bold color combinations. Mariano Fortuny combined inspiration from contemporary Middle Eastern clothing and European art, especially Italian renaissance, in pleated dresses that follow the lines of the body. His artistic dresses connote both timelessness—they are not made for special occasions or age brackets and are beyond the seasonal changes of fashion—and femininity that comes “from within,” in the sense that it is less formal and less manifestly visible than the conventional gender code.

The second wave of ethnic fashion came in the late 1960s with such representatives in haute couture as Yves Saint Laurent, Kenzo, and Sonia Rykiel. Also in this period, ethnic style was associated with transcendence of conventions, thereby allowing perceived deeper sensual qualities to be expressed. The philosopher Hélène Cixous said about a jacket by Sonia Rykiel, and by implication about ethnic fashion as such: “A garment which is not a noisy manifestation of the street, but a fine manifestation of the world” (p. 97). She adds, “The dress doesn’t separate the inside from the outside, it translates, sheltering” (p. 98).

In the 1960s and 1970s, ethnic style provided a rich field for fashion without designers: Palestinian scarves, Latin American skirts, Indonesian batik sarongs, Moroccan djellabas, Chinese jackets, rattan baskets, embroidered purses, leather sandals, and tribal jewelry, bought either in special third-world import stores or on long-distance travels, were worn in combination with ordinary clothes. Ethnic style thus became a highly personal as well as cosmopolitan way of dressing, sometimes associated with a political attitude.

An important issue is the position of non-Western fashion designers. When Japanese avant-garde designers, including Issey Miyake, Yohji Yamamoto, and Rei Kawakubo (of Comme des Garçons), presented the most sought-after collections in Paris in the 1980s, the international fashion press wrote them off as a mere exotic—in the pejorative sense of passing—influence. There was a tendency to interpret their designs in the light of traditional Japanese aesthetics, rather than acknowledge them as innovative designers working with a minimalism that self-consciously fused elements of East and West with very few overt ethnic references. In this respect, the Western fashion world has pushed non-Western designers towards self-exoticization. While some Asian fashion designers find it stimulating to apply their creative skills to their cultural backgrounds, others experience the demand for exoticization as devaluation of their talents and skills in the highly globalized fashion business.

In some markets, especially in the United States, there has been considerable recognition of non-Western designers; however, they have tended to remain identified with a particular ethnic style as aesthetic exponents of multiculturalism. A key example is Vivienne Tam: born in China, educated in Hong Kong, resident of New York City in the early 2000s. She incorporates Chinese motifs in her designs, but highly eclectically, so that her clothes have included both Buddhist and Maoist imagery. In contrast to Western designers, whose engagement with ethnic styles tends to be superficial, Tam's consistent work with Chinese aesthetics has led to a deep involvement with cultural tradition, including spiritualism, architecture, medicine, art, and performance.

There are also minority niche markets where diaspora women in the West find their *salwar-kameez*, the so-called Punjabi suit, or their Vietnamese *ao dai*. These markets are typically operated by women entrepreneurs without any formal training in fashion design. They tend to keep in touch with the styles current in the homeland; however, this does not stop them from influencing dynamics of fashion in the West, as was the case with the Punjabi suit in the late 1990s.

Ethnic style in fashion is an important, yet somewhat neglected, area of fashion studies. As fashion continues adjusting to the multicultural condition, both within each Western nation and at the transnational level, ethnic style provides a particularly rich and diverse field of study—one that is likely to produce major future developments in fashion theory.

See also **Fads; Folklore Look; Galliano, John; Miyake, Issey; Saint Laurent, Yves; Yamamoto, Yohji.**

#### BIBLIOGRAPHY

- Bhachu, Parminder. "Designing Diasporic Markets: Asian Fashion Entrepreneurs in London." In *Re-Orientating Fashion: The Globalisation of Asian Dress*. Edited by Sandra Niessen, Ann Marie Leshkovich, and Carla Jones. London: Berg, 2003.
- Cixous, Hélène. "Sonia Rykiel in Translation." In *On Fashion*. Edited by Shari Benstock and Suzanne Ferriss. New Brunswick, N.J.: Rutgers University Press, 1994.
- Kondo, Dorinne. *About Face: Performing Race in Fashion and Theatre*. New York: Routledge, 1997.
- Legrand-Rossi, Sylvie, et al. *Touches d'exotisme, xiv<sup>e</sup>–xx<sup>e</sup> siècles*. Union centrale des arts décoratifs. Paris: Musée de la mode et du textile, 1998.
- Leshkovich, Ann Marie. "The *Ao Dai* Goes Global: How International Influences and Female Entrepreneurs Have Shaped Vietnam's 'National Costume.'" In *Re-Orientating Fashion*. Edited by Sandra Niessen, Ann Marie Leshkovich, and Carla Jones. London: Berg, 2003.
- Skov, Lise. "Fashion-Nation: A Japanese Globalization Experience and a Hong Kong Dilemma." In *Re-Orientating Fashion*. Edited by Sandra Niessen, Ann Marie Leshkovich, and Carla Jones. London: Berg, 2003.

Steele, Valerie, and John Major. *China Chic: East Meets West*. New Haven, Conn.: Yale University Press, 1999.

Tam, Vivienne, with Martha Huang. *China Chic*. New York: Regan Books, 2000.

Lise Skov

#### EUROPE AND AMERICA: HISTORY OF DRESS (400–1900 C.E.)

For historians, the naming in 395 C.E. of two consuls, or emperors—one for the Eastern and one for the Western parts of Europe—marks the end of the Roman Empire. As the Western empire gradually fell under barbarian control, the empire in the East (its capital in Constantinople) flourished. Dress in Byzantium was an amalgam of Roman and Eastern styles. From the East came elaborate ornaments, decorative motifs, and textiles—especially those of silk. The result was extensive use of embroidery, appliqué, precious stones, or woven designs added to the long or short tunics and some of the draped outer garments characteristic of Roman dress.

As the major cultural center, these styles of the Byzantine court influenced all the courts of Western Europe from about 400 to 900 C.E. It was not until after the tenth century that a European economic recovery began, making Byzantine influences somewhat less important.

#### Dress in the Early Middle Ages

The period from 400 to 900 C.E. in Western Europe is known as the Dark Ages. As the name implies, the picture of cultural developments over this period is somewhat obscure. Clear images of dress are few. Apparently dress in Europe combined Roman forms with those of the barbarians. Men wore long or short tunics with a sort of trousers that were gaitered (wrapped close to the leg) with strips of cloth or leather. Women wore an under tunic and an outer tunic covered by a cape, or mantle. Married women covered their hair with a veil. Among royalty and the upper classes, Byzantine influences were most evident in the use of silk fabrics, manufactured in Byzantium and imported, and in ornamental bands that trimmed sleeves, necklines, hemlines, and other areas of tunics.

The basics of dress remained fairly constant in the eleventh and twelfth centuries of the Middle Ages for both men and women. Next to his body a man typically wore *braies*, an undergarment similar to underpants, and a shirt. A woman wore a loose-fitting undergarment called a chemise. Undergarments were made of linen. Outer garments for both men and women consisted of an under tunic and an outer tunic. These were most likely made of wool. For important occasions, royalty might wear silk. Men of higher status who did not need to be physically active wore longer tunics. The under tunic often was of a contrasting color or fabric and showed at the hem, the neckline, and the end of the sleeves. Art shows both solid and figured fabrics, although solid colors predominate.



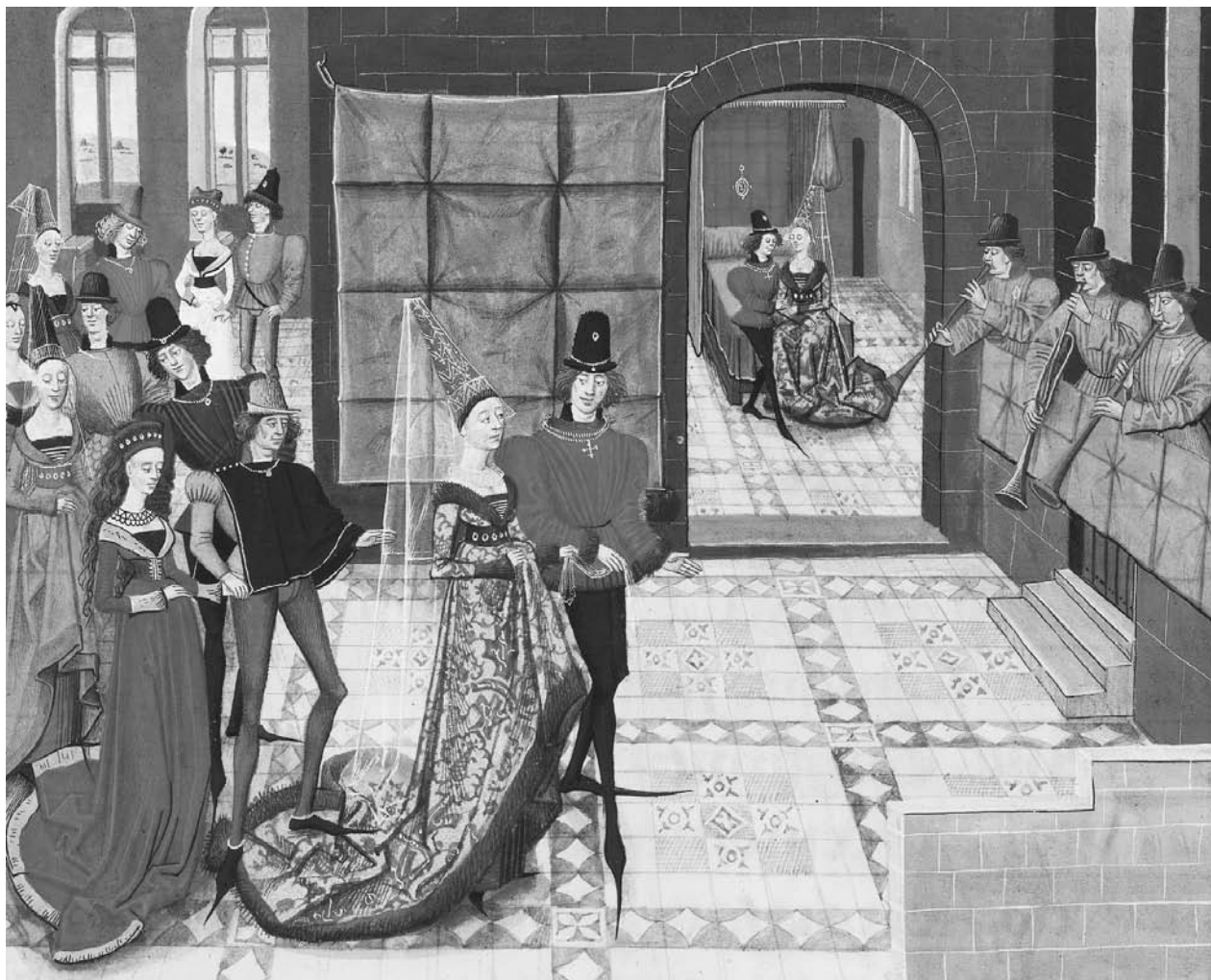

**Medieval bridal procession.** An illustration from the tale *L'histoire de Renaud de Montauban* depicts the types of clothing worn by the upper class in the late fifteenth century. © BIBLIOTHÈQUE NATIONALE DE FRANCE. REPRODUCED BY PERMISSION.

### Twelfth-Century Changes in Dress

By the twelfth century, artistic and literary evidence indicates that significant changes in political, economic, technological, and social life had begun to affect clothing. After the Roman government of Europe broke down, local rulers administered smaller or larger areas. Charlemagne (768–814), one of the kings of a Germanic tribe called the Franks, came to exercise significant power over much of Western Europe and was crowned emperor by the pope in Rome in 800 C.E. This empire did not long survive Charlemagne.

A feudal society developed in which local lords granted land (fiefs) to subjects who, in turn, provided loyalty, payment, and military support to the lord. These lords or kings built castles where large numbers of people lived and worked. Such centers provided a stage for the display of status, which was often expressed through dress.

As the European economy prospered and courts expanded, the Christian church served as a unifying force with its central authority, the pope, in Rome and local bishops in important cities and towns. When the pope called on the many feudal lords and their soldiers to liberate the Holy Lands from the Muslims, who had taken control of that region, thousands responded. Their reasons for joining the Crusades ranged from genuine religious fervor to opportunities for looting and pillaging. The impact on dress was significant. The crusaders, who continued their warfare for almost 200 years, brought back new fabrics, design motifs, and clothing styles that were adapted for European dress. At the same time, civilian dress incorporated elements of military dress.

While the Crusades increased trade and communication with the Middle East, European traders were rekindling trade with the Far East as well. Marco Polo

(c. 1254–1324) wrote of his adventures as a trader in a book that helped to encourage commerce with the Far East.

In decline over the post-Roman period, urban centers once again became the hubs of production and trade after the feudal period. Technological advances in the production of textiles such as water-powered fulling (finishing) of wool, a horizontal loom at which the worker could sit and use foot treadles and a shuttle, and a spinning wheel that replaced the hand spindle all served to increase the capacity of the growing textile industry. Craftsmen formed guilds that set standards and pay rates. Trade opportunities expanded, and wealth extended beyond the courts and royalty to this newly affluent merchant class.

### The Beginnings of Fashion

Though the precise origins of fashion change in dress are still debated by costume historians, it is generally agreed that the phenomenon of a large number of people accepting a style for a relatively short period of time began during the Middle Ages. The aforementioned social and economic changes established the necessary conditions for fashion. Textile manufacturing advances provided the raw materials needed for increased production and consumption of clothing. The courts provided a stage for display of fashions. Social stratification was becoming less rigid, making it possible for one social class to imitate another. Increased trade and travel spread information about styles from one area to another.

Evidence of the international spread of information about style change can be found in developments in the arts. Architectural styles changed radically after circa 1150 when buildings in the Romanesque style gave way throughout Europe to the newer Gothic forms. Both used carvings as ornamentation and to tell biblical stories. These, along with the images portrayed in stained-glass windows, have served as a major source for information about dress. Manuscript illumination also began to show more lay figures dressed in contemporary costume.

These statues and drawings of the twelfth century show alterations in fit that clearly resulted from changes in the cut of clothes. Instead of being loose tunics, garments followed the lines of the body closely from shoulder to below the waist where a fuller skirt was sewn to the upper bodice. Sleeve styles varied. Some outer tunic sleeves were shorter in order to show more of the under tunic sleeve. Some were wide, and some were so elongated that they had to be knotted to keep from dragging on the ground.

French writers of the period called elaborate versions of these fitted styles *bliants*. The garment is described as being made of expensive silk fabrics. Its appearance indicates that the fabric was probably manipulated using bias (diagonal pieces with greater stretch) insets to assure a close fit and that elaborate pleats were used in the skirt. Clearly advances were being made in clothing construction.

*Chainse*, another French term, seems to refer to a pleated garment that was probably made from light-weight linen and may have been worn alone as a sort of housedress by women (Goddard 1927). Some versions of these garments seem to have closed by lacing, which allowed a closer fit.

### Dress in the Middle Ages: 1200–1400

With the increased variety of dressing styles, terminology for items of clothing in these early periods grows more complicated and confusing. Names for garments often come directly from French. Frequently English-speaking costume historians adopt these French terms. This is especially evident when costume historians write about medieval styles of the thirteenth century and after. From this time on, the under tunic was usually called a *cote*; the outer tunic, a *surcote*, a word that has gained English usage.

The layering remained the same as in earlier centuries and undergarments did not change radically, but the cut and fit of outer garments has started to alter with greater frequency. Also, a number of new outdoor garments appeared. These included the *garnache*, “a long cloak with capelike sleeves,” the *berigaut* or *gardecorps*, “a cloak with long, wide sleeves having a slit below the shoulder through which the arm could be slipped,” and the *chaperon*, “a hood cut and sewn to a chape” [cape] (Tortora and Eubank 1998).

The influence of important individuals on style is evident. The reign (1226–1270) of the pious King Louis IX of France coincided with a turn toward looser fitting, more modest, and less ostentatious dress.

Around the middle of the fourteenth century, a wider range of types of dress appeared. At the same time, dress for men and women started to diverge, length of skirt being a major difference. Men of all classes now wore short skirts. One important short-skirted garment was the *cotehardie*. The exact features of this garment seem to have varied from country to country, and it was probably a variant of the *surcote*. The Cunningtons, writing about English costume, define the term as a garment with a front-buttoned, low-waisted, fitted bodice with fitted sleeves that ended at the elbow in front and had a hanging flap at the back, with the bodice attaching to a short skirt (1952).

Under this garment, men wore a garment variously called a *pourpoint*, *gipon*, or *doublet*. In commenting on problems of terminology, Newton observes, “It is doubtful whether at any one time the exact differences between an *aketon*, a *pourpoint*, a *doublet*, a *courtpiece*, and a *jupon* were absolutely defined. In France the *cotehardie* comes into this category, and in England, from the early 1360s, the *paltok*” (1980). Probably adopted for civilian wear from a padded military garment, the *pourpoint* (later more likely to be called a *doublet*) attached to hose with laces that had sharp metal tips known as “points.”





***Maria Leczinska, Queen of France, by Louis Tocque, oil on canvas, 1740.*** Skirts worn by the upper echelons of French society in the eighteenth century were up to eight feet wide. The skirt's broadness was created by hoops near the hem or padding at the hip. REUNION DES MUSEES NATIONAUX/ART RESOURCE, NY. REPRODUCED BY PERMISSION.



This combination might be worn alone or under an outer garment. Hose were worn either with shoes or boots or had leather soles and required no shoes. Shoes often had very long, pointed toes and were called *poulaines* or *crack-owes*, which may testify to a possible origin in Poland. Upper-class men wore the most extreme of these styles and thereby showed that they did not need to do any hard labor.

The *houppelande* was another important garment that appeared about 1360. Made in either thigh or mid-calf length or long, it was fitted over the shoulders, then fell in deep, tubular folds and was belted at the waist. Sleeves could be quite elaborate, sometimes long and full and gathered in at the wrist or widening at the end and falling to the floor. Fur trim was common.

Although women were wearing *houppelandes* by the end of the fourteenth century, they were more common in the fifteenth century. Other styles for women included close-fitting gowns, sometimes with either sleeved or sleeveless surcotes. Certain garments were visual statements of status. French queens and princesses wore surcotes cut low at the neck, with enormous armhole openings through which a fitted gown could be seen, and a hip-length stiffened panel with a row of jeweled brooches down the front. A full skirt was attached to the panel.

The imposition of sumptuary laws (limits placed on spending for luxury goods) on dress indicate that the elite classes feared that the lower classes were attempting to usurp their status symbols. Fashionable dress had become affordable to more people, and legislators attempted to restrict by rank the types of fur used, the types and quantities of fabric, kinds of trimmings, and even the length of the points of shoes. These laws were not obeyed and rarely enforced.

During the fifteenth century, styles continually evolved. Men's doublets grew shorter and hose longer, looking much like modern tights. A new construction feature, the codpiece—a pouch of fabric closed with laces—allowed room for the genitals. *Houppelandes* underwent some changes in style and construction, becoming more elaborate in trimming and sleeve construction. A short, broad-shouldered garment, sometimes called a jacket, had an attached skirt that flared out from the waist.

Women wore *houppelandes* and fitted gowns. One style appears so often in art that it has become almost a stereotype for modern illustrators who want to show medieval princesses. This gown had fitted sleeves, a deep V-neck with a modesty piece filling in the V, a slightly high waistline with a wide belt, and a long, trained skirt. Another style seen in Northern European art is a loose-fitting gown with close-fitting sleeves, a round neckline, and fullness falling from gathers at the center front. Some sources call this gown a roc.

**Accessories.** In the earlier centuries, medieval head coverings were relatively simple: veils that covered their hair

for adult women and hoods or small caps like modern baby bonnets, called coifs, that tied under the chin for men. By the fifteenth century, upper-class men and women were wearing many fanciful styles. Men's hoods were wrapped turbanlike around the head, sometimes made with wide, padded brims. The prevalence of turbans may reflect contacts with the Orient. Hats with high crowns and with small brims resembled a loaf of sugar and were called sugar loaf hats. Adult women's hair was still covered, but coverings were often of decorative net fabrics, padded rolls, or tall, flat or pointed, structures. Lightweight, sheer veils were often attached.

Other accessories included purses, belts, and jewelry. Belts were often a mark of status, being highly ornamented and jeweled.

### Dress in the Italian Renaissance: 1400–1600

In Italy circa 1400, scholars turned to the literature and philosophy of ancient Greece and Rome as a source of ideas about their world. Historians examining this period assigned the name “Renaissance” (French for “rebirth”) to this time when a new focus on humanism contrasted with the medieval emphasis on spirituality.

These ideas spread from Italy to Northern Europe, influencing scholars and creative artists. The artists created realistic portraits and scenes of daily life and showed clear views of dress even to the point of showing where the seams were located. They faithfully depicted the lush velvets, satins, and brocades worn by their sitters.

Royalty wore the most lavish garments, but the well-to-do merchant classes could easily imitate court styles. Inter-marriage among the rulers of European countries provided one means of spreading fashions from one country to another as royal brides and grooms dressed themselves and their retinues in the latest styles from their home country.

By the sixteenth century, the recently developed printing press was turning out books that purported to show clothing styles in different parts of the world. Such books, which are of some use to costume historians, require careful evaluation because many of the styles depicted are imaginary and contain both realistic and inaccurate representations.

**Predominant styles.** Styles worn in Italy in the early fifteenth century showed some similarities to those of Northern Europe in the thirteenth through fifteenth centuries. At the same time, with the proximity of Italy to the Middle East, Asian influences are evident in fabrics with Eastern design motifs, in clothing showing some similarities to Turkish robes, and in headwear in turbanlike forms. Part of the differences in styles came from the Italian failure to adopt northern styles such as the extreme pointed-toed shoes and the V-necked, high-waisted women's gown. Silhouettes of women's gowns were wider than those in the north. Necklines were low.

Bodices were attached to gathered skirts. Many gowns and men's doublets or jackets were made of figured velvets, brocades, and damasks produced by skilled Italian weavers. Small puffs of fabric of contrasting color were pulled through the elbow, armhole, and some seam lines.

This decorative idea became a feature of men's styles all over Europe in the early years of the 1500s. The exterior fabric was slashed and puffs of contrasting color pulled through the slits to make elaborate decorations. The silhouette for men grew wide and full.

Italians styles remained somewhat different from those of the north until the later 1500s when Spain, France, and Austria came to dominate the Italian city-states. By the sixteenth century, international events helped to move Spanish styles to the center of the fashion stage. Christopher Columbus's voyage to America in 1492 made Spain, which had financed the trip, rich. When Charles V became not only king of Spain but also ruler of the Low Countries and what has become Germany, Spanish influences spread throughout Europe. Dark, rich textiles were made into women's garments with fairly rigid, hourglass-shaped silhouettes. A stiff, hooplike structure held out skirts. Handsome black-on-white embroideries ornamented collars and undergarments. By the latter years of the century, the conservative, narrower, more rigid lines of Spanish origin also predominated for men.

Portraits and inventories of clothing provide an excellent picture of the dress of the colorful monarchs of England, Henry VIII and Elizabeth I, as well as that of the rulers of France and Spain. The evolution of men's shoulder shapes from broad at the beginning of the century to narrower, and of women's skirts from inverted cone shapes to barrel-like forms (called farthingales) is clear evidence of fashion as an integral part of dress. Narrow white frills at the neck grew wider, rounder, and still wider to become huge, stiff, starched, lace ruffs, which in the sixteenth century eventually subsided into wide, flat collars.

### Dress in the Baroque and Rococo Period: 1600–1700

The styles in the fine arts from about the end of the sixteenth century to the first several decades of the eighteenth century is called baroque. Elements characteristic of baroque styles include extensive ornamentation, curved forms, and freely flowing lines, all in relatively large scale. The dress of the period clearly reflected these tendencies. Those who could afford to wear fashionable dress did so. The courts remained the most important stage on which to display opulent clothing. It has been said that Louis XIV (king of France from 1643 to 1715) used fashionable dress as a political tool, keeping his courtiers so busy following court etiquette and style that they had neither the funds nor the time to plot against him.

Clothing also played a political role in England. The royalist supporters of the King opposed the Puritan fac-



**Eighteenth-century suit.** During the reign of King Charles II, the three-piece suit, which consisted of knee breeches, a vest, and a jacket, became the standard dress for men. THE METROPOLITAN MUSEUM OF ART, PURCHASE, IRENE LEWISOHN BEQUEST AND POLAIRE WEISSMAN FUND, 1996. (1996.117A-C) PHOTOGRAPH, ALL RIGHTS RESERVED, THE METROPOLITAN MUSEUM OF ART. REPRODUCED BY PERMISSION.

tion. The Puritans wanted to reform the Church of England and stress a simpler, more moralistic, and less lavish lifestyle. The resulting civil war led to the defeat and execution of King Charles I, after which a Commonwealth replaced the monarchy for about eighteen years. The Puritans dressed in more somber styles with little ornamentation. Their "Roundheads" nickname came from the short hairstyles they adopted. Portraits, inventories, and other written records show that although the Puritans stressed simplicity, their clothing followed fashionable lines. Among the affluent Puritans, high-quality, expensive fabrics were in use.

The Pilgrims who settled in Massachusetts in 1620 were Puritans. The dress styles of the American colonists of the seventeenth and eighteenth centuries lagged behind those of Europe, but were otherwise the same. Only the trappers and explorers appear to have adapted some of the more practical elements of Native American dress such as moccasins; almost nothing made its way back across the Atlantic. Native Americans were depicted by portrait painters in garb usually containing European elements, whereas the dress of early American colonists is virtually indistinguishable from dress in Europe.

By contrast, trade with the Far East had a significant impact on fashion. These influences can be seen in the fabrics imported from India, China, and Japan and in some specific garments. The vest adopted by Charles II of England is one example of Eastern influences. The prototype of the vest may have been Persian men's coats (Kuchta 1990).

When the English monarchy was restored, Charles II (son of the executed Charles I) returned from exile in France under the protection of Louis XIV, and Puritan dress modifications were eclipsed by French influences and the court once again became the arbiter of style. One noteworthy item of dress adopted by King Charles II was the vest, the forerunner of what became a virtual uniform for men in the eighteenth century and later: the three-piece suit. Its seventeenth-century style consisted of knee-length breeches, a long, buttoned vest that reached just below the knee and covered the breeches, and a jacket of the same length over this.

The Puritans were not the only seventeenth-century group to deviate from contemporary styles. The conservative nature of Spanish society was probably responsible for the preservation of older styles and a slower adoption of new ones. The wide-skirted farthingale of the sixteenth century disappeared in the rest of Europe in the early seventeenth century. Spanish upper-class women adopted this style in the mid-1600s. The Spanish *guardinfante* (literally, "infant guard") consisted of an oval farthingale, very wide from side to side, worn with a bodice that extended far below the waistline to cover the top of the skirt. As Reade noted, "Since exertion was difficult for anyone wearing it, the vogue emphasized social distinctions" (1951). Spanish men continued wearing the ruff and trunk hose longer than men elsewhere in Europe. By the eighteenth century, the Spanish dressed in mainstream fashion.

How individuals acquired clothing differed depending on social status. Less affluent families bought used clothing or produced their own clothing, mostly by having women of the family make the clothes. Those sufficiently affluent hired professional tailors. Although most professional tailors were men, women did the fine hand and ornamental sewing. In 1675, responding to a petition from a group of French women seamstresses that they be allowed to make women's clothes, Louis XIV

permitted the formation of a guild of women tailors. Over time, using female dressmakers to make women's clothes and male tailors to make men's suits became customary.

Some economists consider the economic changes that took place in England in the late seventeenth and eighteenth centuries a consumer revolution. Consumer interest in less costly imported cottons from India led businesses to stimulate demand for fashionable goods in order to increase their profits. To accomplish this, they needed to provide information about current fashions to potential customers. Engraved, sometimes hand-colored, pictures of the latest fashions were sold. Dolls dressed in the latest styles were circulated, and by the late eighteenth century, paper dolls showing current styles were also available. Styles were given names, and fashion terminology increased exponentially.

As the demand for fashionable goods grew, more fibers, yarns, and fabrics were needed. Such requirements helped to fuel the industrial revolution and its mechanization of production. Consumer demand for cotton led to increased settlement in the colonies of the New World and to the use of slaves to cultivate and harvest the fiber. As supplies of cotton increased, invention of the cotton gin met the need to process more fiber. Inventors improved machines for spinning and weaving. Mass production of fabric made inexpensive fabrics available. As a result, by the end of the eighteenth century, following fashion was possible for all but the very poor and slaves.

The name "rococo" has been assigned to the subtle changes in the art and dress styles of the period from about 1720 to 1770. Rococo styles are characterized by smaller scale but still curvilinear lines; more delicate ornamentation; and Asian, Gothic, and floral motifs. After 1770, the arts and architecture experienced a classical revival. These neoclassical influences came into clothing styles gradually and were accepted as the prevailing mode only toward the close of the century.

The three-piece suit became the predominant component of men's clothing. Throughout the eighteenth century, men wore knee breeches, a vest, and an outer coat. When coat, vest, and breeches were made of the same fabric, the outfit was called a "ditto suit." The length of the vest, and the cut of both the vest and coat, varied over time. Early in the century, coats and vests were wide and full. When the coat was buttoned, it hid the vest. By midcentury, the coat was slimmer. So was the vest, which also shortened. The coat no longer buttoned shut, but remained open and the vest and breeches were visible. For formal wear, coats and vests were elaborately embroidered or made of very decorative fabric. A frock coat was looser and shorter than coats for more formal occasions. Early in the century, frock coats were worn in the country, but gradually they were also deemed proper for more formal wear.

The silhouettes and the ornate woven, embroidered, or printed designs of the fabrics from which upper-class



women's dresses were made in the 1700s reflected the curvilinear forms of baroque and rococo arts. The shape of skirts changed gradually. After the early eighteenth century, when loose, full sacque gowns were popular, the silhouette altered and bodices fitted the front of the body closely. Necklines were low, square, or round. In back some dresses were fitted, while others had full pleats at center back that opened into a loose, flowing skirt. Costume historians of the nineteenth century called this style a "Watteau back" after Jean-Antoine Watteau, an eighteenth-century artist, who frequently painted women in this style of dress.

Skirts were held out by supporting hoops (called *paniers* in France) that were first cone-shaped, then dome-shaped, next narrow from front to back and wide from side-to-side. By the period from 1740 to 1760, skirts were enormously wide (as much as 2 ¾ yards). Double doors helped to accommodate the passage of women in these *panier*-supported dresses, and small tables often had raised edges to prevent objects from being swept from them by a passing skirt. After the 1760s, *paniers* were replaced by cushions or pads worn at the hip, and the fullness of skirts moved toward the back.

Hints of the classical revival in the arts could be seen in the dress of small girls, who wore high-waisted, slender white muslin dresses reminiscent of Greek Doric chitons. Women, too, began to wear white muslin dresses and moved away gradually from the full-skirted silhouette, but the adoption of styles closely modeled on Greek and Roman women's dresses came only after the French Revolution (1789–1795).

### The French Revolution and the Empire Style

Costume is said to reflect the *zeitgeist*, or "spirit of the age," and fashions of the late eighteenth and early nineteenth centuries are frequently cited to illustrate this point. Political developments in France were to a considerable extent inspired by the examples of the ancient Greek and Roman republics. As previously noted, classical influences were already evident in architecture, and the fine and decorative arts. By the last decade of the eighteenth century, they permeated women's dress as well.

Because the marble statues of antiquity had been bleached white over time, it was believed that the Greeks and Romans had worn white garments. The high-waisted styles of Hellenic Greek Doric chitons served as the model for slender, white muslin dresses with high waistlines. Fashionable women wore classically inspired sandals. Men cut their hair in "Titus style" (named after a Roman emperor). Women dressed their hair *à la Greque*. Although specific details changed year-by-year, the high-waisted dresses were the basis of a fashionable silhouette that was to persist for more than two decades.

### Dress in the Nineteenth Century

Many cultural forces contributed to the stylistic changes of the nineteenth century. These included the industrial

revolution, the French Revolution, changes in women's roles, changes in the political climate, the expansion of the United States, and artistic movements.

The industrial revolution produced not only technological but also social and economic changes that affected dress. The ability to produce textiles rapidly and less expensively facilitated participation in fashion. As industrialization brought more women into the workforce, giving them less time to make clothing for their families, by the end of the century, some garments were being mass-produced. Rural workers who migrated to urban areas needed different kinds of clothes.

As the United States expanded, it gradually took on a more important role in the Western world as a producer of raw materials and manufacturer of goods. Technological innovations and refinements made in the United States such as the patenting and distribution of the first commercially successful sewing machine, the development of the sized-paper pattern, and the invention of machines that could cut multiple pattern pieces contributed to the growth of mass fashion. Immigration brought skilled workers to work in the mass production of clothing, and immigrant consumers expanded the market for inexpensive ready-to-wear.

Although ready-to-wear fashion came later to Europe than to the United States, Europe remained the center of innovation in fashions. British tailoring set the international standard for menswear. And the beginnings of the haute couture in Paris at midcentury confirmed the preeminent place of Paris in women's fashion.

Charles Worth is considered to have been the father of the haute couture. He first came to public notice around 1860 when the French empress Eugénie began wearing clothes he had designed. His atelier was soon known around the world, and women from Queen Victoria to Parisian courtesans were dressed by Worth. Worth was instrumental in founding an organization of French couturiers, the *Chambre Syndicale de la Couture Parisienne*, in 1868 that regulated the French high-fashion industry.

Political events on both sides of the Atlantic also influenced dress. For example, the restoration of the French monarchy spawned a host of fashions named after earlier royals and the Italian revolutionary leader Giuseppe Garibaldi inspired women to wear red blouses like those of his soldiers.

The nineteenth-century movement of Europe and America toward more egalitarian societies contributed to an overall revolution in men's dress. The lavishly decorated eighteenth-century suits with knee breeches worn by the nobility were, henceforth, replaced by dark, trousered, three-piece suits. The skill of its tailoring and quality of the fabric in these suits attested to the status of the wearer.

Through its ornamentation and obvious cost, women's clothing had to bear the burden of attesting to the wealth and social standing of the family. Thorsten Veblen (1857–1929) recognized this role for women in his classic study, *Theory of the Leisure Classes*. He noted that upper-class women's clothing showed that their husbands or fathers could afford to spend lavishly on elaborate clothing (conspicuous consumption) and, furthermore, these women could not do any menial labor when encumbered by such dresses (conspicuous leisure) (Veblen 1936).

At the same time, some women were beginning to question the roles assigned to them in nineteenth-century society. After the accession of Queen Victoria to the throne of England in 1837, the ideal Victorian matron was wife and mother of a large family who ran the household smoothly, supervised the servants, and led a sedate, scandal-free life. The example set by abolitionists working to free the slaves at the time of the American Civil War led some women to state that they, too, were held in a type of bondage. Some women active in the women's suffrage movement believed that women's clothing was a severe handicap to freedom of movement and physical activity. Attempts to reform dress and establish more rational styles for women such as the Bloomer costume were not especially successful at first. The Bloomer costume (named after women's-rights author and lecturer Amelia Bloomer, one of its more visible proponents) consisted of a shorter version of the full-skirted dress of the 1840s worn over a pair of full trousers gathered in to fit tightly at the ankle. The style was based on the dress worn by women in European health sanitariums (Foote 1980). Though abandoned by suffragettes after a few years, photographs show that the style was adopted by some American women settlers for the westward trek and the rigors of pioneer life. Variations of the style also showed up in gymnastics classes for young women, evidence of increased importance given to women's health and fitness.

By the 1890s, women were participating actively in many sports. Bicycling was especially popular and special dress, including bloomer suits called rationals and split skirts, had been adopted.

Throughout history, connections between the fine arts and dress can be found. In the nineteenth century, the pre-Raphaelites and participants in the aesthetic movement made conscious efforts to apply their philosophies to dress. In rejecting contemporary art forms, the pre-Raphaelites drew their inspiration from the art of the Middle Ages and the Renaissance. The artists painted women in idealized costumes from these earlier periods, and women of the group began to wear styles based on the paintings while rejecting the tight corseting and wide skirts of the 1840s and 1850s. In the 1880s and 1890s, the ideas of the small pre-Raphaelite group inspired followers of the more popular aesthetic movement. Women wore no corsets, few or no petticoats, and large

leg-of-mutton sleeves. Oscar Wilde, British writer, lectured about aestheticism in a softly-fitted velvet jacket and knee breeches worn with a wide, soft collar and loose necktie. While this costume was worn in protest, the protest was against the aesthetics of the time and not against the inconvenient and unhealthy aspects of dress to which feminists and health reformers objected.

Means of spreading information about current styles expanded. Magazines for women incorporated hand-colored, engraved fashion plates, making it possible for women of all socioeconomic levels to see styles from Paris and keep abreast of current fashion each month. Full-sized paper patterns were bound into some magazines in the late 1800s. The invention of photography in the 1840s provided another way of spreading style information.

***Silhouette and style changes.*** The nineteenth century was marked by increasingly rapid style changes. Costume historians recognize this by dividing the century into a number of relatively short fashion periods that cover ten to twenty years. These periods were characterized by an incremental evolution of fashions year-by-year that eventually added up to a distinct new style.

The more somber styles worn by men throughout the 1800s showed only relatively subtle changes. One can see parallels in the cut of men's suits and the silhouette of women's dresses. When women's sleeves were large, men's tended to be enlarged; when women's waists were narrow, tailors made men's jackets with nipped-in waistlines. But it was in women's clothing that the more pronounced changes in style were evident.

The Empire period (1790–1820) is named after Napoleon Bonaparte, the first Emperor of France. For women, the high-waisted, relatively narrow silhouette first seen in the late 1700s continued to be the predominant line throughout this period. In fashion terminology, this high waistline placement is still known as an "empire waist."

The expanded trade with the Far East and the military campaigns of Napoleon in Egypt fueled fashions with Asian links. Imported cashmere shawls were all the rage. Napoleon tried to ban the importation of these shawls in order to protect the French textile industry. Soon European mills were copying them. The output of the mills in the town of Paisley, Scotland, was so prodigious that the shawls became known as paisley shawls.

Year by year, subtle changes appeared in the Empire styles until the high waistline had moved lower, approaching the anatomical waist, the skirt had flared out, and sleeves had grown larger, eventually becoming enormous. By the 1820s, that line was distinctive enough for costume historians to see this as a new period that they named after the art and literary movements of the same time: the Romantic period (1820–1850).

Differences in style between the late Romantic and the later Crinoline period (1850–1870) were subtle. In

some costume histories, the period from circa 1838 to 1870 is known as the early Victorian period, Victoria having acceded to the British throne in 1837. The most distinctive aspect of the silhouette of this period was the increasing width of the skirt, the return of the waistline to its natural anatomical position, and a dropped shoulder line. Until the invention of the cage crinoline, or hoopskirt, in the mid-1800s, skirts were held out by heavy layers of starched petticoats that were often reinforced with fabric stiffened with horsehair (*crin* is French for “horsehair,” and *lin*, “linen,” hence the name of the fabric: crinoline). The originator of the nineteenth-century hoopskirt is unknown. The basic structure was a series of horizontal hoops of whalebone or steel of gradually increasing size that were fastened to vertical tapes. Far lighter than the many layers of petticoats, the hoop was an immediate success.

The hoopskirt itself went through numerous transitions, being first round, and then gradually swinging its fullest areas to the back. As the back fullness increased, the front flattened, and by 1870, the bustle had taken over as the preferred shape.

The silhouette of the Bustle period (1870–1890) might be divided into three distinct phases. In the first phase (1869–1877) the fullness at the back of the dress was supported by a bustle. Bustles were structures equipped with some device to hold skirts out in the back. The skirt shape was flat in front with a full, draped fall of fabric and ornamentation down the back. Most sleeves were three-quarters length or longer and were set in at the shoulder instead of being dropped below the shoulder on the arm, as in the Crinoline period. Bodices were tightly fitted. In the second phase (1878–1883), the bustle itself disappeared, garments were fitted closely from neck to hip in what was called a cuirass bodice, below which the skirt remained tight at the front. The decoration of the skirt dropped to below the hips in back. Many skirts had long, ornamental trains. In the third phase (1883–1890), the bustle structure returned with a vengeance, looking like a shelf at the back of the dress. Dresses had high, tightly fitted collars and very close-fitted bodices.

By the final decade of the nineteenth century, the back fullness of the Bustle period had diminished to a few pleats. The silhouette was hourglass-shaped, with enormous leg-of-mutton sleeves balancing a full, cone-shaped skirt that was wide at the bottom. The ubiquitous high-standing collar remained, however.

#### BIBLIOGRAPHY

- Baines, V. B. *Fashion Revivals from the Elizabethan Age to the Present Day*. London: B. T. Batsford, Ltd., 1981.
- Boucher, E. *20,000 Years of Fashion*. London: Thames and Hudson, Inc., 1987.
- Breward, C. *The Culture of Fashion: A New History of Fashionable Dress*. New York: St. Martin's Press, 1995.
- Byrde, P. *The Male Image: Men's Fashion in England 1300–1970*. London: B. T. Batsford, Ltd., 1979.
- Chenoune, F. *A History of Men's Fashion*. Paris: Flammarion, 1993.
- Cunnington, C. W., P. E. Cunnington, and C. Beard. *A Dictionary of English Costume 900–1900*. London: Adam and Charles Black, 1972.
- Davenport, M. *The Book of Costume*. 2 vols. New York: Crown, 1948.
- DeMarly, D. *Fashion for Men: An Illustrated History*. New York: Holmes and Meier, 1985.
- . *Dress in North America*. New York: Holmes and Meier, 1990.
- Tortora, P., and K. Eubank. *Survey of Historic Costume*. New York: Fairchild Publications, 1998.
- Waugh, N. *The Cut of Men's Clothes, 1600–1900*. London: Faber and Faber, 1964.
- . *The Cut of Women's Clothes, 1600–1930*. New York: Theatre Arts Books, 1968.
- Medieval Dress*
- Cunnington, C., and P. Cunnington. *Handbook of English Medieval Costume*. Northampton, U.K.: John Dickens, 1973.
- Evans, J. *Dress in Medieval France*. Oxford: Clarendon, 1952.
- Goddard, E. R. *Women's Costume in French Texts of the 11th and 12th Centuries*. New York: Johnson Reprints, 1973.
- Newton, S. M. *Fashion in the Age of the Black Prince*. Totowa, N.J.: Rowan and Littlefield, 1980.
- Piponnier, F., and P. Mane. *Dress in the Middle Ages*. New Haven, Conn.: Yale University Press, 1997.
- Scott, M. *The History of Dress: Late Gothic Europe, 1400–1500*. New York: Humanities Press, 1980.
- . *Visual History of Costume: 14th and 15th Centuries*. London: B. T. Batsford, Ltd., 1986.
- Renaissance Dress*
- Arnold, J., ed. *Lost from Her Majesty's Back*. Birdle, Bury, England: Costume Society, 1980.
- Ashelford, J. *The Visual History of Costume: The 16th Century*. New York: Drama Book, 1983.
- . *Dress in the Age of Elizabeth I*. New York: Holmes and Meier, 1988.
- Birbari, E. *Dress in Italian Paintings, 1460–1500*. London: John Murray, 1975.
- Cunnington, C. W. *Handbook of English Costume in the Sixteenth Century*. Boston: Plays, 1972.
- Frick, C. *Dressing Renaissance Florence: Families, Fortunes, and Fine Clothing*. Baltimore, Md.: Johns Hopkins University Press, 2002.
- Herald, J. *Renaissance Dress in Italy, 1400–1500*. New York: Humanities Press, 1981.
- Vecellio, C. *Vecellio's Renaissance Costume Book*. Mineola, N.Y.: Dover Publications, Inc., 1977.
- Seventeenth- and Eighteenth-Century Dress*
- Baumgarten, L. *What Clothes Reveal*. Williamsburg, Va.: The Colonial Williamsburg Collection, 2002.



- Buck, A. *Dress in 18th Century England*. New York: Holmes and Meier, 1979.
- Cumming, V. *A Visual History of Costume: The 17th Century*. New York: Drama Book, 1984.
- Cunnington, C., and P. Cunnington. *Handbook of English Costume in the Eighteenth Century*. London: Faber and Faber, 1957.
- . *Handbook of English Costume in the Seventeenth Century*. London: Faber and Faber, 1972.
- Delpierre, M. *Dress in France in the Eighteenth Century*. New Haven, Conn.: Yale University Press, 1998.
- De Marly, D. *Louis XIV and Versailles*. New York: Holmes and Meier, 1988.
- Hart, A., S. North, and R. Davis. *Fashion in Detail from the 17th and 18th Centuries*. New York: Rizzoli International, 1998.
- Kuchta, D. M. "Graceful, Virile and Useful": The Origins of the Three-Piece Suit." *Dress* 17 (1990): 118.
- Reade, B. *Costume of the Western World: The Dominance of Spain*. London: Harrap, 1951.
- Ribeiro, A. *A Visual History of Costume: The Eighteenth Century*. New York: Drama Book, 1983.
- . *Dress in Eighteenth Century Europe: 1715–1789*. New York: Holmes and Meier, 1985.
- . *Fashion in the French Revolution*. New York: Holmes and Meier, 1988.
- . *The Art of Dress: Fashion in England and France 1750–1820*. New Haven, Conn.: Yale University Press, 1995.
- Roche, D. *The Culture of Clothing: Dress and Fashion in the Ancien Régime*. New York: Cambridge University Press, 1994.
- Nineteenth-Century Dress*
- Bradfield, N. *Costume in Detail*. London: Harrap, 1975.
- Buck, A. *Victorian Costume*. Carlton, Bedford, England: R. Bean, 1984.
- Cunnington, C., and P. Cunnington. *A Handbook of English Costume in the 19th Century*. London: Faber and Faber, 1970.
- Earle, A. M. *Costume of Colonial Times*. Detroit: Gale Research Company, 1974.
- Foote, S. "Bloomers." *Dress* 5 (1980): 1.
- Foster, V. *A Visual History of Costume: The 19th Century*. New York: Drama Book, 1983.
- Hall, L. *Common Threads: A Parade of American Clothing*. Boston: Bulfinch Press, 1992.
- Newton, S. M. *Health, Art, and Reason: Dress Reform of the 19th Century*. New York: Schram, 1976.
- Severa, J. *Dressed for the Photographer. Ordinary Americans and Fashion 1840–1900*. Kent, Ohio: Kent State University Press, 1995.
- Steele, V. *Paris Fashion: A Cultural History*. New York: Berg, 1998.
- Veblen, T. *Theory of the Leisure Class*. New York: Viking Press, 1936.
- Walkey, C., and V. Foster. *Crinolines and Crimping Irons: Victorian Clothes. How They Were Cleaned and Cared For*. London: P. Owen, 1978.

Phyllis Tortora

**EVENING DRESS** Simply put, evening dress is the prevailing style prescribed by fashion to be worn in the evening. Though straightforward in its basic definition, there are surprisingly complex expectations related to appropriateness of fashionable dress for evening. Regardless of the era, evening dress is intricately connected to fashions of the day, with specific characteristics that distinguishes it from everyday dress. An evening gown is a special form of dress that amplifies a woman's femininity and often proclaims her desirability. In general, necklines are low, bodices are tightly fitted, arms are bared, and skirts are extravagantly designed. Fabric surfaces vary from reflective to matte, textured to smooth, and soft to rigid. Gowns may be bouffant or hug the body, emphasizing every curve and swell. Regardless of these distinctions, there tends to be an overall emphasis on the woman's body and in many instances on the gown itself. Through the decades, undergarments have played a critical role in reshaping the body into the desired silhouette, from corsets and petticoats of the nineteenth century to control-top panty hose and padded Wonderbras of the twenty-first century.

### Historical Overview

Although formal court dress has existed for centuries, there is consensus among dress historians that evening dress materialized as a discrete category in the mid-1820s. It is probably not coincidental that this form of dress emerged at roughly the same time the Romantic Movement in art and literature surfaced as an influence in European and American cultures. Romantics accentuated passion and sentiment, placing a greater emphasis on love rather than on duty. Other cultural factors such as increased fabric production, a thriving textile industry, and an expanding ready-made clothing industry resulted in greater access to resources. By the 1820s, fashion had been fairly democratized. Additionally, Parisian and American fashion magazines experienced a burgeoning popularity among women in the United States and Europe. Dresses of the 1820s were frequently identified in *Godey's Lady's Book* and *Peterson's Magazine* according to explicit activities or time of day. Women viewed fashion plates with captions like morning dress, day dress, walking dress, promenade dress, carriage dress, seaside dress, dinner dress, evening dress, or ball dress. From these labels, it seems the evening dress was born.

### 1820 to 1899

During the last eighty years of the nineteenth century, women's fashions evolved from an X-shaped silhouette (1820s) to the introduction of the cage crinoline (1850) through the bustle period (1870–1890) and ended with an hourglass silhouette (1890s), and in each era evening dress took its profile from current styles of the day. However, evening dress was discernible by its use of opulent and supple gauze and satin fabrics, the cut of the neckline—typically low or off-the-shoulder—short sleeves, and by

the lavishness of surface embellishment. Skirts were especially complex in ornamentation—with layers of swags and puffs and such trim details as artificial flowers, ribbons, rosettes, and lace. During the bustle period and the 1890s, trains were frequently attached to full-length skirts.

### 1900 to 1945

The early years of the twentieth century included a progression in women's fashions from an S-shaped silhouette to a revival of Empire styles to the flapper style of the 1920s to the bias-cut fashions of the 1930s. With the exception of the latter part of this time-period, evening dress followed the conventions of daytime dress. Necklines tended to be deep and wide, sleeves were short or were mere straps on the shoulder, skirt lengths varied according to fashions and frequently involved complex floating panels, draping, or layers. Fabrics were extravagantly pliant chiffons and satins and luxuriant velvets and taffetas. Pleating, embroidery, lace, beading, fringe, braid, and ruffles decorated the surfaces.

During the 1930s, evening dress made an uncharacteristic split from daytime styles, remaining floor-length while daywear fluctuated in length from mid-calf to ankle. Evening gowns were designed in bias-cut styles and were usually constructed with an open back, with fabric skimming the body to the hips and flaring out and to the floor.

### 1945 to 2003

The late 1940s through the early 1960s saw the last of a singular identifiable fashion for evening. Dior's New Look—with a rounded shoulder line, a nipped waist, and either an exceptionally full skirt or a pencil-slim skirt—defined the style of the day. Evening dress generally paired strapless bodices with full rather than narrow skirts and it was not unusual for skirts to be floor-length.

By the 1960s, a plethora of options in evening wear emerged. Mini-skirted straight dresses were made from metallic fabrics or brilliantly patterned fabrics, and surfaces may have been trimmed with sequins, beads, or plastic bits. By the late 1960s, evening dresses had returned to floor length. Pantsuits with full-legged trousers and palazzo pants paired with a coordinating top also became viable options. In the mid-1970s, fashionable evening dress was typically long and made from fabrics that were soft, clinging, and often knitted. In the 1980s, the glamour of evening dress contrasted with professional dress for career women and integrated bright and vibrant colors with plenty of glitter, embroidery, sequins, and beading. Lacroix introduced a gown with a short wide puffy skirt, nicknamed *Le Pouf*, which was eagerly copied and made available to the masses. Wide-skirted, short styles called mini-crinolines were also popular. By the late 1980s, evening dresses made from elasticized fabrics hugged the body were short, and were strapless or had tiny shoulder straps. In the early 1990s, basic slip dresses made from soft crepe fabrics became popular. By the mid-1990s, full-skirted, short, strapless evening gowns re-



**1913 advertisement for evening dress created by Georges Barbier.** This dress, with its low neckline, tight bodice, draped skirt, and eye-catching fabrics, is a typical example of the style of early twentieth century evening wear. © HISTORICAL PICTURE ARCHIVE/CORBIS. REPRODUCED BY PERMISSION.

emerged. Also fashionable were lace or elaborately decorated bustiers and fitted evening gowns and black was the color of choice.

### Contemporary Use of Evening Dress

Today, evening dress is limited to such formal or semi-formal events as balls, high school proms, gala fundraisers, pageants, and awards ceremonies. While men's dress tends to be quite typical (usually a standard dark-colored suit or tuxedo), women's gowns vary drastically from demure black garments to revealing objets d'art, as might be seen on celebrities at the Academy Awards. Despite the range of possibilities for contemporary evening



**Nineteenth-century dresses.** The evening dress on the left is a classic example of the X-shaped silhouette that was prevalent during the 1820s. © BETTMANN/CORBIS. REPRODUCED BY PERMISSION.

dress for women, a gown will undoubtedly include a low-cut neckline, a constricting bodice, bared arms, and lavish skirts. Evening dress draws attention to a woman's body and serves to define her gender, establishing her as an object to be gazed upon by her audience.

See also **Ball Dress; Cocktail Dress.**

#### BIBLIOGRAPHY

- Boucher, François. *20,000 Years of Fashion: The History of Costume and Personal Adornment*. New York: Harry N. Abrams, 1987.
- Laver, James. *Costume and Fashion: A Concise History*. London: Thames and Hudson, Inc., 1982.
- Lobenthal, Joel. *Radical Rags: Fashions of the Sixties*. New York: Abbeville Press, 1990.
- Milbank, Caroline Rennolds. *New York Fashion: The Evolution of American Style*. New York: Harry N. Abrams, 1989.
- Mulvey, Kate, and Melissa Richards. *Decades of Beauty: The Changing Image of Women 1890s–1990s*. New York: Octopus, 1998.
- Payne, Blanche, Geitel Winakor, and Jane Farrell-Beck. *The History of Costume*. 2nd ed. New York: HarperCollins Publishers, Inc., 1992.

Russell, Douglas A. *Costume History and Style*. Englewood Cliffs, N.J.: Prentice-Hall, 1983.

Steele, Valerie. *Women of Fashion: Twentieth-Century Designers*. New York: Rizzoli International, 1991.

———. *Fifty Years of Fashion*. New Haven, Conn., and London: Yale University Press, 2000.

———. *The Corset*. New Haven, Conn., and London: Yale University Press, 2001.

Tortora, Phyllis, and Keith Eubank. *Survey of Historic Costume*. 3rd ed. New York: Fairchild Publications, 1998.

Watson, Linda. *Vogue: Twentieth Century Fashion*. London: Carlton Books Ltd., 1999.

Jane E. Hegland

**EXTREME FASHIONS** In any single culture, the definition of what constitutes an extreme fashion may be agreed upon; but extreme fashion, like beauty, is in the eye of the beholder. Particularly between Western and non-Western views there are very different ideas of what is excessive or outlandish, or verging on the unacceptable.

The most common denominator of fashion considered “extreme” is exaggerated broad shoulders and wide skirts, or small waists and small feet. It is possible to make the general statement that in Western Europe the body is usually amplified or reduced by the application of a garment or accessory, while in some African and Asian cultures, the body is permanently altered, and the alteration often augmented by accessories or garments.

As Harold Koda states, “There is no doubt that much of the material has a multitude of meanings and intentions: displays of status, wealth, power, gender, cultivation, ceremony, and group affiliations” (p. 11). An extreme fashion may, and most likely does, perform more than one function simultaneously. Ragnar Johnson points out that any type of body adornment is rarely, if ever, purely utilitarian, and the form that adornment takes depends on a variety of factors, from the resources available in a particular society to the relative social standing and aesthetic tastes of the individual.

Permanent body alteration, which is more common in African and Asian cultures, has traditionally held a negative connotation in the West, with the relatively recent exception of tattooing. The word “mutilation” is often used to describe any lasting modification to the natural body's appearance. To mutilate is defined in Webster's dictionary as: “to deprive . . . of a limb or other essential part, to disfigure, or make imperfect.” Since the latter part of the twentieth century, however, publications have elucidated these traditions and have begun to erode the notion that dramatic permanent alterations are forms of deviant or perverse behavior.

The culture of study and criticism of extreme fashion is probably as old as extreme fashion itself. The European clergy were active in their criticism of fashions that distorted or exaggerated the human silhouette. A fifteenth-



century source criticized stiffened skirts for their ability to deceive the viewer as to the fullness of a woman's hips, and therefore her suitability as a child-bearer. Travelers recorded non-Western fashions as soon as the Age of Exploration commenced by the late fifteenth century.

### Western Fashions

For the Western fashion historian, the corset is perhaps the first example of extreme fashion that comes to mind. Stiffened underbodies were worn by women from the 1400s through the early twentieth century. The corset, or "stays" as they were also called, was condemned when incidents of "tight-lacing," to make the waist appear as small as possible, began to appear. In that form, it was seen as deforming and detrimental to women's health almost from its inception. However, not all societies value a diminished female waistline; in Japan the waist is emphasized but not minimized with the obi—a wide sash of contrasting fabric—wrapped over the kimono, and tied at the back with an elaborate knot of huge proportions.

The exaggerated skirt appeared in the form of the round sixteenth-century farthingale, the wide eighteenth-century pannier, and nineteenth-century hoopskirt or crinoline. All of these skirt shapes in their largest forms could prevent a woman from moving freely. In her classic study of undergarments, Norah Waugh surmises that upper-class women could afford to be more physically burdened by fashion, as they were not required to be active, as in battle. This premise has led to a situation where women's fashion is more often criticized for its extreme manifestations in Western society, but men have participated in extreme displays as well.

The pleated collar known as a ruff is one example of a style worn by both sexes in Western Europe, notably at the court of Elizabeth I. It developed from a simple embellishment of the collar and grew to the cartwheel proportions evident in portraits of the late sixteenth and early seventeenth centuries. The face-framing function of the ruff was appreciated by men and women alike.

### Non-Western Fashions

The most commonly remarked upon body modification of Eastern cultures is certainly the practice of Chinese footbinding. Feminist theorist Andrea Dworkin suggests that footbinding and other body "mutilations" (quoted in MacKendrick, p. 3) may contain an element of romanticized tolerance of pain that signals the participant's character. In the case of footbinding, which is only performed on women, it may signal the willingness of women to endure the pain of childbirth and other forms of self-denial, as she is rendered unable to walk on her tiny feet.

While a long, slender neck has been valued in the West, the practice of elongation of the neck reached exaggerated proportions among the Paduang people of Burma. The wearing of metal neck rings, increasing in number over time, forces the collar bones down, giving



**Paduang woman.** Some women of the Paduang tribe begin wearing a brass coil around their necks at age six, adding a ring or two every year until the age of sixteen. © KEVIN R. MORRIS/CORBIS. REPRODUCED BY PERMISSION.

the illusion of a longer neck, and the rings are worn constantly to further decorate the exaggerated area.

Piercing of the ears has become entirely acceptable in Western society, but in numerous African cultures the pierced hole is manipulated to accept larger and larger accessories. This practice is notable in Ethiopia, where piercing is only the beginning of a long process of stretching either the earlobes or the lower lip in order to receive further decorations, known as labrets.

### Twentieth-Century Fashions

The advent and acceptance of cosmetic surgery has brought permanent body modification to mainstream Western society. Generally the results are not meant to be extreme, or even noticeable, but the possibility of dramatic alteration has been explored. Bodybuilding can be pushed to the extreme as well.

Two genres of extreme fashions have developed in the twentieth century: fashions that are deliberately

provocative or unattractive, and those that are intellectually challenging. In the 1970s, the punk movement, with Vivienne Westwood as its leading design creator, set out to provoke shock with its mix of overt sexual display and aggression. In the 1990s, the work of the Japanese avant garde was seen as unintelligible in the accepted fashion vocabulary. Rei Kawakubo's 1997 "Lumps" collection exemplifies the intellectual challenge to either renounce or alter traditional ideas of beauty.

"Although one zone may be the focus of a period or culture, any extreme intervention is often accompanied or balanced by other manipulations of the body's proportions," notes Koda (p. 11). No matter how outrageous or extreme a garment or accessory is, it does not function in a vacuum and is stabilized by the other zones of the fashionable body.

See also **Footbinding**.

#### BIBLIOGRAPHY

- Johnson, Ragnar. "The Anthropological Study of Body Decoration as Art: Collective Representations and the Somatization of Affect." *Fashion Theory* 5, no. 4 (2001): 417–434.
- Koda, Harold. *Extreme Beauty: The Body Transformed*. New York: Metropolitan Museum of New York, 2001.
- MacKendrick, Karmen. "Technoflesh, or 'Didn't That Hurt?'" *Fashion Theory* 2, no. 1 (1998): 3–24.
- Robinson, Julian. *The Quest for Human Beauty: An Illustrated History*. London, 1998.
- Rubin, Arnold, ed. *Marks of Civilization: Artistic Transformations of the Human Body*. Los Angeles: University of California, 1988.
- Rudofsky, Bernard. *The Unfashionable Human Body*. New York: Doubleday and Company, 1971.
- Wagh, Nora. *Corsets and Crinolines*. London: B. T. Batsford, Ltd., 1954. Reprint, New York: Theatre Arts Books, 1970, 1991.
- Wilcox, Claire. *Radical Fashion*. London: Harry N. Abrams, 2001.

Melinda Watt

**EYEGLASSES** The term "eyeglasses" is used to indicate lenses that are held up to or worn before the eyes, either as an aid to vision or as a fashion accessory. This term formerly encompassed a wide variety of single and double lenses and kinds of frames; in modern American usage, it is taken to mean spectacles (the term more commonly used in the United Kingdom). Originally a practical vision aid, eyeglasses have at various times in their history served as such fashionable symbols of status, learning, and other desirable qualities that they have even been worn by those with perfect vision. Although their form has been influenced by fashion throughout their history, not until the twentieth century did they truly evolve from a practical necessity into a fashion accessory in their own

right, becoming a vehicle for design, individual expression, and enhancement of personal appearance.

#### Early History

The earliest double eyeglasses, which appeared in Italy by the late thirteenth century, took the form of two magnifying lenses with the handles riveted together, and needed to be held in front of the eyes or balanced on the nose. The round lenses were ground from beryl, quartz (known as pebble), or glass, with frames of iron, brass, horn, bone, leather, gold, or silver. As eyeglasses were primarily used by monks, scholars, and those both learned enough to be able to read and wealthy enough to own them, they became associated with persons of importance. The demand for eyeglasses increased dramatically with the invention of printing in the fifteenth century, and mass-production methods evolved to produce inexpensive eyeglasses for the new reading public.

Once spectacles were available to everyone by the early seventeenth century, the wealthy and fashionable sought means of distinguishing themselves from the lower classes. Spectacles, therefore, dropped out of fashion, at least for public wear, and would remain so for the next three centuries. Since fashionable people did still need to see clearly, beautifully made hand-held lenses came into favor, in part because they provided an opportunity for elegant gesture and display. Variations included the so-called perspective glass, a small single lens with a handle, worn attached to a cord or ribbon around the neck; elaborate scissors glasses, a pair of lenses held up to the eyes with a long, Y-shaped handle; and small spyglasses (telescopes), which were incorporated into fans and walking sticks, or worn around the neck like charms.

#### The Eighteenth and Nineteenth Centuries

In the early eighteenth century, spectacle-makers introduced steel spring bridges and frames, and the first spectacles with temples (rigid side pieces). Improvements in the design of eyeglasses continued in the nineteenth century; rimless glasses became commonly available around the middle of the century, and the invention of fine steel wire riding bow and cable temples, with the end curved around the ear, greatly improved the fit and practicality of spectacles in the 1880s. Frames of tortoiseshell, steel, silver, and gold were the most commonly worn, joined later in the century by celluloid, hard rubber, gold-filled, and aluminum frames.

Although spectacles had become quite practical by the nineteenth century, it was still not considered attractive, especially for ladies, to wear them in public. The lorgnette, a pair of folding glasses held up to the eyes by a handle at the side, was introduced around 1780 and remained popular for women through the early twentieth century. A new eyeglass style for men, the monocle, a single lens held in the eye socket and attached to a ribbon or cord, experienced brief periods of popularity in the 1820s, 1880s, and 1910s. The most commonly worn

form of eyeglasses from the mid-century on, however, for both sexes, was the pince-nez. These consisted of two small lenses (oval, rectangular, octagonal, or semicircular), attached by a bridge, with a variety of spring and nosepiece arrangements to keep them in place. Lacking temples, they were known at the time simply as eyeglasses (as distinct from spectacles). They were usually worn attached to a cord, chain, or ribbon, which was attached to the vest or dress, looped around the neck, or, for ladies, attached to a hairpin. An 1883 article in the *New York Times* declared that eyeglasses had “virtually driven spectacles off the field,” and noted that they were considered so stylish that some young ladies and gentlemen were adopting them simply “because they think it gives them a distingué appearance” (p. 14).

### The Twentieth Century

In the early twentieth century, though pince-nez continued to be worn, spectacles finally began to gain acceptance. Large, round spectacles, with heavy frames of real or imitation horn or tortoiseshell (referred to as horn-rims) were at first affected by university students, and by the 1910s had become fashionable for both men and women. They were considered to give an air of wisdom, seriousness, and sincerity to the wearer, an association exploited by the silent film comedian Harold Lloyd, whose earnest and sympathetic screen persona owed a great deal to his trademark horn-rim glasses.

By the mid-1920s, horn-rims began to decline in popularity, as women’s bobbed hair and close-fitting hats made heavy frames uncomfortable and too conspicuous, and as Harold Lloyd’s popularity made men see them as a symbol of comedy. Smaller rimless spectacles and frames of white gold became the style, and through the 1930s more attention was paid to making eyeglasses more becoming, largely by making them as inconspicuous as possible. Glasses were still considered a necessary evil, as famously summed up by Dorothy Parker in her 1927 poem “News Item”: “Men seldom make passes / At girls who wear glasses.” In an attempt to change this state of affairs, Altina Sanders designed the harlequin frame, with solid dark rims and upswept sides based on the shape of a carnival mask, which was introduced in New York in 1939. These were considered the first glasses designed solely with the idea of improving a woman’s appearance, and eyeglasses began to be taken seriously as a fashion accessory.

By the early 1940s, eyeglasses were available in a wide variety of colored plastic frames to harmonize with the wearer’s complexion or costumes, and women were advised to have a spectacle wardrobe, with jeweled frames for evening and special frames for beach and sportswear. After World War II, variations on the harlequin shape (later known as cat-eye or cat’s-eye) were the dominant style for women, and they were available in many new textures and finishes—opalescent pastels, laminates of glitter, or patterned fabric—and embellished with carving, gilding,



**Marilyn Monroe wearing eyeglasses.** After World War II, eyeglasses began to be fashionable and fun, and designers began marketing them in various colors, shapes, and styles. © BETTMANN/CORBIS. REPRODUCED BY PERMISSION.

metal studs, and rhinestones. More conservative styles were also available, with solid eyebrow bars and clear plastic or light metal lower rims. With glasses so prominent, chic eyeglass wearers were advised to keep other accessories simple and subdued, advice that fit in well with the short coiffures, off-the-face hats, and button earrings of the 1950s. For men, the heavier metal-and-plastic brow-bar frame and thick black horn-rims such as those worn by the singer Buddy Holly were the most popular styles, and remained so well into the 1960s.

### Fashion Eyewear: 1960s to the Early 2000s

In July 1965, just as the use of contact lenses was on the rise, *Vogue* magazine devoted its “Beauty” section to eyeglass fashions, and noted that women with no eye problems were now “writing their own prescriptions: ‘20/20, but plenty of frame’” (p. 108). Simple, solid-colored frames, whether small and rectangular or large and round or hexagonal, were offered by a newly formed industry group, the Fashion Eyewear Group of America.



By 1965, the first retro fad in eyewear had emerged from the boutique scene in London and New York, and early-twentieth-century-style granny glasses, as worn by such celebrities as John Lennon and the Byrds's Roger McGuinn, continued in vogue for the rest of the decade.

The fashion designers Elsa Schiaparelli and Claire McCardell, among others, had designed some eyewear lines as early as the 1950s, but the first high-profile line of designer eyeglasses was launched in 1969 by Christian Dior. The trend toward designer frames continued in the 1970s, with designers such as Yves Saint Laurent, Diane von Furstenberg, and Halston joining the field. The decade's signature look was oversized frames with rounded corners, in semitransparent pastels or faux tortoiseshell, with tinted or gradient lenses in colors to coordinate with the wearer's eye makeup. Bolder styles, often with shiny gold accents and curved or wavy temples, were balanced by the high-volume, blow-dried hairstyles of the time, and were well-suited to the glitz of disco fashions.

In the 1980s, many more designer frames were available, often with visible designer logos, in new eyewear boutiques carrying thousands of styles for men, women, and children. The same style trends continued, but there were also harder-edged styles, in brighter, solid colors, in response to the new boxy silhouette and large, bold costume jewelry. Some retro styles from the 1940s and 1950s were produced to complement the trendy preppy and nerd looks. Toward the end of decade, designers such as Ralph Lauren, Giorgio Armani, and Calvin Klein started a move toward smaller frames, with cleaner, refined styling. These were updated versions of the serious horn-rims of the 1910s and 1920s, and celebrities such as Richard Gere soon adopted the new look, inspiring

even contact-lens wearers and those with 20/20 vision to invest in new frames.

In the late 1980s, eyeglasses for sports, or performance eyewear, began to be reconsidered as an industrial design problem, and new materials such as titanium were employed to create stronger, lighter frames. In the 1990s, the high-tech, minimalist aesthetic carried over into fashion eyeglasses, and the quest for refinement continues to be an important theme in eyeglass design. At the same time, in synch with the decade's retro fashions, designers began to look more carefully at the past, and frame styles from every decade of the twentieth century are available in the twenty-first, either updated or faithfully reproduced, from a multitude of designer collections. Even deliberately unbecoming glasses have been embraced as nerd chic, a symbol of hipness and sophistication, and baby boomers have transformed humble drugstore reading glasses into a fun fashion accessory.

See also **Sunglasses**.

#### BIBLIOGRAPHY

- Acerenza, Franca. *Eyewear Gli Occhiali*. San Francisco: Chronicle Books, 1997.
- "All About Eye-Glasses." *New York Times* (6 May 1883): p. 14. Excellent contemporary account of nineteenth-century eyewear fashions.
- Corson, Richard. *Fashions in Eyeglasses*. London: Peter Owen, 1967. Excellent and readable survey.
- Schiffer, Nancy N. *Eyeglass Retrospective: Where Fashion Meets Science*. Atglen, Pa.: Schiffer Publishing, 2000. Short on documentation, but many examples are shown.

*Susan Ward*



---

**Moroccan slippers for sale.** In the sixteenth century, Moroccan clothing styles began to be influenced by the Ottoman Empire, and some clothing has retained a Turkish flair. (See *Africa, North: History of Dress*) © Jeremy Horner/Corbis.

---





**Left top: Kapayo Indian tribe.** Due to the hot, humid climates found in many South American countries, some natives wear very little clothing, distinguishing themselves instead with ornamentation such as body paint, jewelry, and headdresses. (See America, South: History of Dress) © Whitmore Hank/Corbis Sygma.

**Right top: Indigenous men in Tarabuco, Bolivia.** The men carrying goods here exhibit colorful, wrap-around ponchos over wide-legged, short pants. Felt fedoras as well as helmet-like hats covering the ears, unique to Tarabuco, are also featured. (See America, South: History of Dress) © Lynn A. Meisch.

**Bottom: Kuna woman holding a mola.** The cotton molas (blouses) worn by the women of the Kuna tribe are brightly colored and often feature images pulled from advertisements or popular entertainment. (See America, Central, and Mexico: History of Dress) © Peter Guttman/Corbis.







---

**Veil designed by Elsa Schiaparelli.** Italian designer Elsa Schiaparelli often collaborated with artists such as Salvador Dalí to add distinctive accents to her clothing designs. (See Art and Fashion) © Philadelphia Museum of Art/Corbis.

---





**Top: Gauguin's *Tahitian Women on the Beach*.** The long, flowing dress seen on the right-hand figure is found on many of the Pacific Islands. Tahitians call it a *pareau*, but Americans know it better as the muumuu or the Mother Hubbard. (See *Asia, Southeastern Islands and Pacific: History of Dress*) © Bettmann/Corbis.



**Bottom: *Dancers in Evening Wear*, 1914, by Georges Barbier.** A prolific and skillful artist, Barbier contributed widely to fashion magazines, albums, almanacs, and other publications. (See *Barbier, Georges*) © Historical Picture Archive/Corbis.







---

**Top: Batik from Sri Lanka.** The *semen*-style batik features plants and animals in bright colors. Batik is a form of resist dyeing, some form of which has historically been practiced on all continents except Australia and the Pacific Islands. (See Batik) © Christine Osborne/Corbis.

**Bottom: 1925 Lesage embroidery.** François Lesage, a Parisian designer, has been creating garments with embroidered beadwork since 1924. The Lesage design house spends 16,000 hours a year making samples for its twice-annual collections. (See Beads) © Julio Donoso/Corbis Sygma.

---

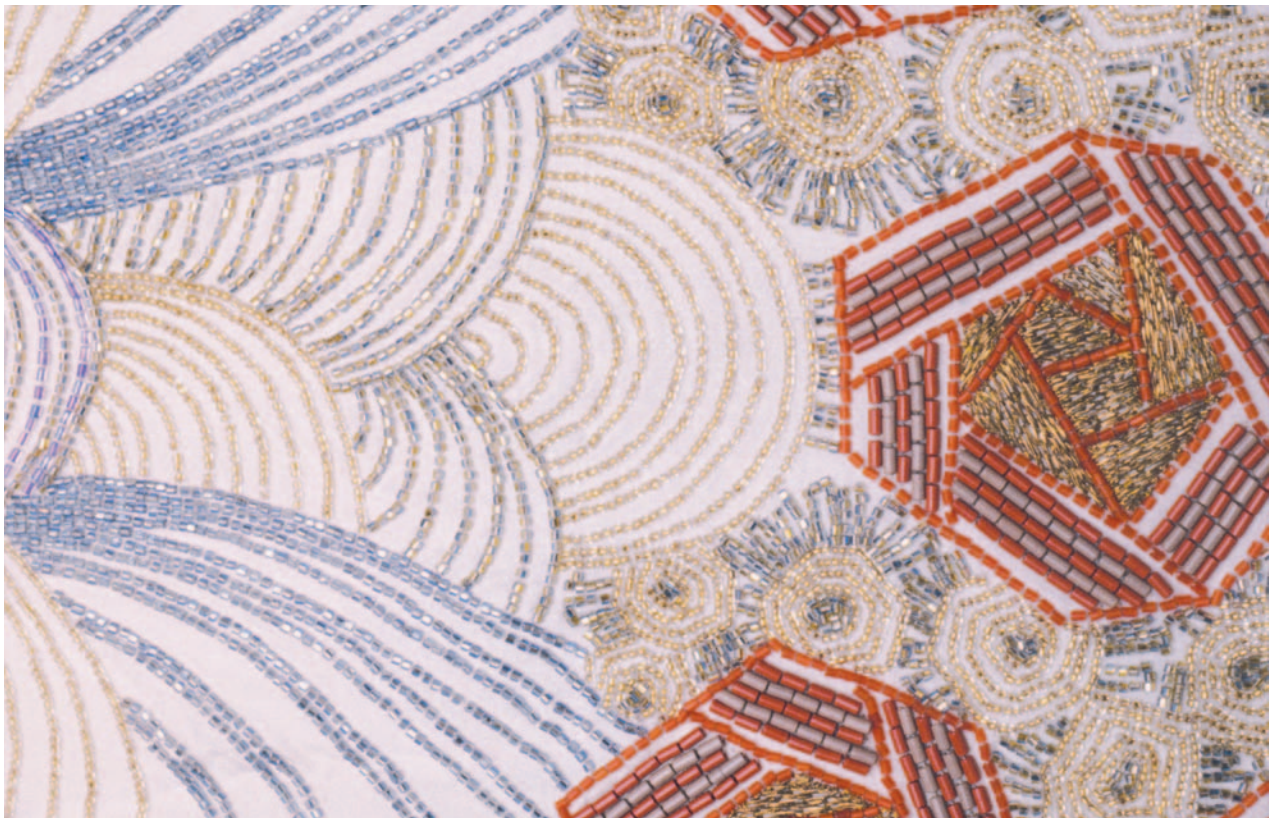





---

**Dries van Noten autumn/winter 2002–2003 collection.** Belgian designer Dries van Noten's fashions are known for their ethnic or historic tones and often evoke a sense of exoticism. (See Belgian Fashion) Dries van Noten; Autumn/Winter 2002–2003. Photo: Yelena Yemchuk.

---





---

**Woman in carnival costume and makeup.** Carnivals have been found in many countries and cultures throughout the centuries, and outrageous dress appears to have always been a key element. (See Carnival Dress) © Bob Krist/Corbis.

---







---

**Below: Woman in colorful chador.** Worn by many Muslim women for reasons of modesty, the Islamic *chador* first developed during the Abbasid Era (750–1258), when the dynastic color was black. Most women continue to wear a black chador, though some choose color. (See Chador) © Keren Su/Corbis.

**Right top: Corset worn by Madonna.** Jean-Paul Gaultier designed this famous corset for Madonna's 1991 *Blonde Ambition* tour. Thanks to Gaultier, Vivienne Westwood, and other designers, corsets saw a resurgence of popularity in the late twentieth century. (See Corset) AP/Wide World Photos.

**Right bottom: Russian formal court dress.** During the nineteenth century, distinctive court dress began to evolve in many countries. Russian court dress incorporated traditional design elements, while other nations based their designs on military patterns. (See Court Dress) © Reproduced by permission of The State Hermitage Museum, St. Petersburg, Russia/Corbis.

---





SCRIBNER LIBRARY OF DAILY LIFE



**ENCYCLOPEDIA OF  
CLOTHING  
AND FASHION**





## EDITORIAL BOARD

---

***Christopher Breward***

London College of Fashion

***Joanne B. Eicher***

University of Minnesota

***John S. Major***

China Institute

***Phyllis Tortora***

Author of *Understanding Textiles*, *The Fairchild Encyclopedia of Fashion Accessories*, and *The Fairchild's Dictionary of Textiles*

SCRIBNER LIBRARY OF DAILY LIFE



ENCYCLOPEDIA OF  
CLOTHING  
AND FASHION



VOLUME 2:  
Fads to Nylon

*Valerie Steele, Editor in Chief*

**CHARLES SCRIBNER'S SONS**

*An imprint of Thomson Gale, a part of The Thomson Corporation*

**THOMSON**  
—★—™  
**GALE**





## Encyclopedia of Clothing and Fashion

Valerie Steele, Editor in Chief

© 2005 Thomson Gale, a part of the Thomson Corporation.

Thomson and Star Logo are trademarks and Gale and Charles Scribner's Sons are registered trademarks used herein under license.

*For more information, contact*

Thomson Gale

27500 Drake Rd.

Farmington Hills, MI 48331-3535

Or you can visit our Internet site at

<http://www.gale.com>

### **ALL RIGHTS RESERVED**

No part of this work covered by the copyright hereon may be reproduced or used in any form or by any means—graphic, electronic, or mechanical, including photocopy-

ing, recording, taping, Web distribution, or information storage retrieval systems—without the written permission of the publisher.

For permission to use material from this product, submit your request via Web at <http://www.gale-edit.com/permissions>, or you may download our Permissions Request form and submit your request by fax or mail to:

*Permissions Department*

Thomson Gale

27500 Drake Road

Farmington Hills, MI 48331-3535

Permissions Hotline:

248-699-8006 or 800-877-4253 ext. 8006

Fax: 248-699-8074 or 800-762-4058

While every effort has been made to ensure the reliability of the information presented in this publication, Thomson Gale does not guarantee the accuracy of the data contained herein. Thomson Gale accepts no payment for listing; and inclusion in the publication of any organization, agency, institution, publication, service, or individual does not imply endorsement of the editors or publisher. Errors brought to the attention of the publisher and verified to the satisfaction of the publisher will be corrected in future editions.

### Library of Congress Cataloging-in-Publication Data

Encyclopedia of clothing and fashion / Valerie Steele, editor in chief.

p. cm. — (Scribner library of daily life)

Includes bibliographical references and index.

ISBN 0-684-31394-4 (set: hardcover: alk. paper) — ISBN 0-684-31395-2 (v. 1) —

ISBN 0-684-31396-0 (v. 2) — ISBN 0-684-31397-9 (v. 3) — ISBN 0-684-31451-7 (e-book)

1. Clothing and dress—History—Encyclopedias. I. Steele, Valerie II. Series.

GT507.E53 2005

391'.003—dc22

2004010098

This title is also available as an e-book.

ISBN 0-684-31451-7

Contact your Thomson Gale Sales representative for ordering information.

Printed in the United States of America

10 9 8 7 6 5 4 3 2 1



**FADS** Here today, gone tomorrow. It is hard to identify a fad until it has fizzled. Fashion cycles, more generally, vary in speed; fads are those particular fashion cycles that “take us by surprise, but also fade very quickly” (van Ginneken, p. 161). The term “fashion” implies “strong norms” (Crane, p. 1), and although this criterion may also apply to fads, these norms are of shorter duration and within a more limited population. Fred Davis goes so far as to say that fashion itself “somehow manage[s] on first viewing to startle, captivate, offend,” but ultimately “engage[s] the sensibilities of some culturally preponderant public, in America the so-called middle mass” (p. 15). By implication, a fad represents a temporary and limited divergence from a more general path of fashionability; the “so-called middle mass” may never approve.

A perusal of academic books in fashion studies over the last decade reveals that the term “fad” itself may have fallen out of style. Even Arthur Berger’s text *Ads, Fads, and Consumer Culture* includes little mention of fads. Still, popular media feature lists of “what’s hot” versus “what’s not.” Why aren’t these called fads? Perhaps the time-space nexus associated with contemporary fashion cycles is at issue: Influencing the rapidity and scope of “what’s hot” are factors such as a global economy, rapid technological change and media influence, “fast fashion” (or speed-to-market production), and a fashion system that combines branded commodities with stylistic diversity among consumers.

Nevertheless, a case can be made for interpreting the concept of fad for its historical, heuristic, and analytical significance. Issues of time, identity, stylistic detail, expression, and emotion all come into play in contemporary life, regardless of what we call the phenomenon in question. Historically, the term has been used to characterize collective behavior that may range from an article of clothing or an accessory (or how it is worn) to a hairstyle or other way of grooming. Or, it may describe toys or gadgets, or even activities or practices that do not require consumer purchase. Fads tend to be: (1) of a strikingly new or revolutionary quality that sets them apart from current fashion; (2) short-lived, with a rapid growth in popularity and demise; (3) accepted only in, and intensely popular within, small groups or subcultures; and

(4) often “nonessential,” “mostly for amusement,” or a “passing fancy.”

The concept of a fad seems to relate almost as much to who participates as it does to time. According to the *Oxford English Dictionary* the term is related to the earlier concept of fiddfad (short for fiddle-faddle). A fiddfad, dating back to 1754, was a person who gave “fussy attention to trifles.” In the mid-nineteenth century, the terms “fad” and “faddish” were used to refer to shallow or unpredictable patterns of behavior or people.

It is interesting to note that the *Oxford English Dictionary* has not added new entries for the concept since its 1989 edition. However, it has generated related concepts that deserve careful attention: namely, “trendy” and “fashion victim.” Trendiness implies the state of being fashionable and up to date; it also connotes following the latest trend (“sometimes dismissively”). Since the early 1960s, “trendy” and “trendiness” have begun to displace the concept of fad linguistically. By the 1980s, the concept of trendy had become well-entrenched in everyday speech. The connotation of being shallow or narrowly focused persisted; the term still does not describe individuals who are immersed in the larger, “mainstream” issues of the day. Dating back to the eighteenth and nineteenth centuries, the concept of a trend implied divergence from the mainstream—initially in the context of physical or geological manifestations (for example, streams, currents, or valleys). By the 1960s, the idea of trend analysis had taken hold in the social context as well. The idea of a fad was morphing into a “trend.”

Aside from issues of intensified speed, media saturation, and identities and intentions, there is the question of who benefits from fads or trends, and how. Accordingly, Marx and McAdam made an analytical distinction between “spontaneous” and “sponsored” fads. The former appear and spread without the involvement (at least initially) of an entrepreneur or business. Usually a spontaneous fad can be pursued without an extensive monetary commitment; it tends to be behavioral in nature. Examples might include goldfish swallowing in the 1920s or “streaking” (running naked) in the 1970s; both of these fads spread and deceased rapidly as trends on college campuses. In contrast, a sponsored fad tends to be consciously promoted; this is probably most obvious when applied to

toys or gadgets (for example, the “pet rock” fad of the mid-1970s or the Pog craze of the early 1990s).

Although there may be heuristic reasons for making distinctions between spontaneity and sponsorship in fads (just as there might be similar reasons for distinguishing fads from fashions), the two often become inextricably intertwined, especially in a commodified, branded, and celebrity-oriented consumer culture. First, it is difficult to ascertain in advance what will endure. Second, most fads or trends seem to include a commodity in some way, even (maybe especially) if it is somewhat affordable. Third, what may begin as a spontaneous fad (using the materials one has on hand to modify one’s appearance, for example) can quickly become appropriated commercially. The phenomenon of trend spotters, or later, “cool hunters,” took hold in the latter part of the twentieth century. Apparently, some analysts were able to spot or hunt trends so as to capitalize on them in some way.

Subcultural style, in particular, is open to such appropriation. In the mid-1970s, British working-class youth experimented with safety pins as accessories, with the use of Vaseline to spike their hair, and with ways of ripping their clothes. These looks were soon appropriated by top fashion designers and the apparel and beauty industries. Similarly, the hip-hop styles of inner-city (often African American) youth in the United States in the late 1970s became mainstream even in the suburbs of white, middle-class youth populations. Both of these examples were innovated by limited segments of society and then became more mainstream. But the time factor does not quite fit the classic definition of a fad. For example, the “sagging” trend associated with hip-hop male pants styles is still a way some young men of various ethnic backgrounds continue to wear their pants at the time of this writing. Whereas some adults might describe this look as a fad, younger people might simply characterize it as a longer-lasting fashion that resonates with some individuals and groups their age.

The approximately 250-year-old concept of fad reminds us that a fad is likely to be in the eye of the beholder. For example, when does the tendency to be trendy (or faddish) merge into that of becoming a fashion victim? Not surprisingly, the concept of fashion victim is usually used in a diminutive or depreciative way. The implication is that a fashion victim is susceptible to change, without devoting “serious” thought (as might a connoisseur) to the meaning of that change.

Michelle Lee’s 2003 book *Fashion Victim*, intimates that fashion victim is an inclusive concept—not one confined to certain, limited groups within the population: “The Fashion Victim is all around us. The Hollywood startlet who’s personally dressed by Donatella Versace is no less a Fashion Victim than the small-town salesgirl who hops on every fad at her local JC Penney” (p. xi). She goes on to say that a fashion victim is “anyone who has ever looked back at old pictures and cringed” (p. xii).

Fiddle faddle. The concept of a fad is frustrating and difficult to distinguish from fashion in general. Issues of time, identity, fun, commodification, appropriation, looking back, and moving forward all relate to the concept of fad as it has been used historically and analytically. None of these issues is without its own ambiguities. Still, fads, by any name or duration, are likely to remain a part of how we live and change.

See also **Fashion Advertising; Trendsetters.**

#### BIBLIOGRAPHY

- Agins, Teri. *The End of Fashion: The Mass Marketing of the Clothing Business*. New York: William Morrow and Company, 1999.
- Berger, Arthur Asa. *Ads, Fads, and Consumer Culture: Advertising’s Impact on American Character and Society*. 2nd ed. Lanham, Md.: Rowman and Littlefield Publishers, Inc., 2004.
- Crane, Diana. *Fashion and Its Social Agendas: Class, Gender, and Identity in Clothing*. Chicago: University of Chicago Press, 2000.
- Davis, Fred. *Fashion, Culture, and Identity*. Chicago: University of Chicago Press, 1992.
- George, Nelson. *Hip Hop America*. New York: Penguin Books, 1999.
- Hebdige, Dick. *Subculture: The Meaning of Style*. New York: Routledge, 1979.
- Hoffman, Frank W., and William G. Bailey. *Fashion and Merchandising Fads*. New York: Harrington Park Press, 1994.
- Kaiser, Susan B., Richard H. Nagasawa, and Sandra S. Hutton. “Fashion, Postmodernity, and Personal Appearance: A Symbolic Interactionist Formulation.” *Symbolic Interaction* 14, no. 2 (1991): 165–185.
- . “Construction of an SI Theory of Fashion: Part 1. Ambivalence and Change.” *Clothing and Textiles Research Journal* 13, no. 3 (1995): 172–183.
- Lee, Michelle. *Fashion Victim: Our Love-Hate Relationship with Dressing, Shopping, and the Cost of Style*. New York: Broadway Books, 2002.
- Marx, Gary T., and Douglas McAdam. *Collective Behavior and Social Movements: Process and Structure*. Englewood Cliffs, N.J.: Prentice-Hall, 1994.
- Meyersohn, R., and E. Katz. “Notes on a Natural History of Fads.” *American Journal of Sociology* 62 (1957): 594–601.
- More, Booth. “Going Von Dutch.” *Los Angeles Times*, 2 January 2004.
- Nystrom, Paul H. *Economics of Fashion*. New York: Ronald Press, 1928.
- Sproles, George B., and Leslie D. Burns. *Changing Appearances*. New York: Fairchild, 1994.
- Van Ginneken, Jaap. *Collective Behavior and Public Opinion: Rapid Shifts in Opinion and Communication*. London: Lawrence Erlbaum Associates, 2003.

Susan B. Kaiser, Joyce Heckman,  
and Denise Kastrinakis



**FANCY DRESS** Celebrating festivals by wearing masks and disguises has been customary in Europe for many centuries. The eighteenth-century masquerade, forerunner of the fancy dress balls and parties of the nineteenth and twentieth centuries, owes its origin to the Venetian pre-Lent Carnival, developed in the seventeenth century. This was a public, open-air event in which all classes participated in dancing, feasting, and practical jokes. The revelers wore masks and either fanciful decorative costumes or all-concealing dark cloaks called dominoes, to enjoy flirtations and intrigue incognito.

Masquerading, or masking, was introduced as a public entertainment in London in 1710, held first in theaters and from the 1730s at the public pleasure gardens at Ranelagh and Vauxhall. In 1772, the Pantheon was built in Oxford Street to provide a winter indoor venue. Many masqueraders wore a mask and domino over fashionable evening dress, but others chose very diverse costumes. The dress of the commedia dell'arte characters Harlequin, Columbine, Punchinello, and Pantaloon was popular, as were nuns' and monks' habits (worn with subversive intent) and comic Scotsmen, sailors, and savages. Turkish dress for men and women, admired for its exoticism, appeared frequently at masquerades, and elements of *turquerie* were adopted in fashionable dress. Most outfits were probably hired, as advertisements show the existence of several London "habit-warehouses" engaged in this trade.

### Romanticism

The morally questionable masquerade became unfashionable by 1820, but European society's love of fancy dress continued. To accord with the new mood of decorum, fancy balls became the fashion, given either in private houses or as large-scale civic fund-raising events. Masks disappeared, and costumes were based on historical characters (many from Shakespeare's plays or Sir Walter Scott's novels), Turkish and Greek dress inspired by Byron's poems, or the peasant dress of Spain, Italy, and Switzerland. The most admired romantic heroine was Mary, Queen of Scots, whose story combined legendary beauty, doomed love, and a tragic death; her popularity ensured that the "Marie Stuart" cap entered mainstream fashion in the 1830s.



In France the masquerade was a fashionable way to celebrate state occasions. Louis XV attended the *bal masqué* at Versailles, celebrating the marriage of the Dauphin in February 1745, as one of a group of to-piary trees.



**Mrs. W. K. Vanderbilt at a fancy dress ball.** In the latter half of the nineteenth century, fancy dress events became more common, and costumes could be found at department stores. © BETTMANN/CORBIS. REPRODUCED BY PERMISSION.

Large civic balls were reported in detail in the press, with lists of costumes worn. Many women wore "a fancy dress," meaning fashionable evening dress with fanciful trimmings, particularly feathers. Local dressmakers or even the ballgoer herself created these outfits. Ladies' periodicals, especially *The World of Fashion* (first published 1828), included plates of historical or foreign dresses for inspiration. For more elaborate costumes and for men's dress, firms specializing in making and hiring fancy costumes advertised widely. London firms (including Nathan's, which still existed in the early 2000s), rented temporary premises in provincial towns where a ball was planned.

### Imperial Pageants

From the 1860s onward, fancy dress opportunities multiplied. Society papers listed columns of private balls, often celebrating comings-of-age and housewarmings, as well as public balls hosted by lord mayors, children's parties, and clubs' and works' Christmas parties. Such was the demand for ideas for costumes that women's period-



**Print of *La Saison*, showing women in fancy dress.** Civic balls became popular in the mid-1800s, and the press often reported on the costumes of attendees. © Gianni Dagli Orti/Corbis. REPRODUCED BY PERMISSION.

icals, especially *The Queen*, published regular articles and correspondence columns, and from 1879, books were also available; Ardern Holt, *The Queen's* columnist, produced *Fancy Dresses Described*, which ran to six editions by 1896. Popular costumes included “Vandyke” and rococo dress, Japanese dress (inspired by *The Mikado*, 1885), European peasant dress, and allegorical costumes such as Night, Winter, or Folly. By the 1880s, there was a demand for novel and inventive ideas (such as “The Front Hall” and “Oysters and Champagne”), and originality was important. As well as private dressmakers, the newly established department stores in London and provincial cities made fancy dresses for customers.

Queen Victoria's 1897 Diamond Jubilee inspired two of the most lavish fancy dress balls of the century: the Devonshire House Ball given in London by the duchess of Devonshire and attended by royalty and the cream of London society, and the Victorian Era Ball, given in Toronto by the governor general of Canada, Lord Aberdeen, and Lady Aberdeen. At Devonshire House, the guests dressed as famous people from history or fable; the hostess represented Zenobia, queen of Palmyra, and the countess of Warwick was Queen Marie Antoinette. Many of the costumes were couture creations, several by Jean-Philippe Worth (son of Charles). For the Canadian ball, the theme was the British Em-

pire, and many costumes were allegorical: the Aberdeens' daughter represented “The Forests of Canada,” and other ballgoers dressed as “Electricity,” “Postal Progress,” and “Sports and Pastimes.”

### Bright Young Things

Fancy dress fitted the mood of 1920s party-going perfectly. Young people turned the social world topsy-turvy with all-night parties, jazz, cocktails, and exhibitionist behavior. Masks were reintroduced, and the most admired outfits were outrageous or bizarre, with good taste out-of-date. Theme parties became popular: Greek parties, baby parties, Wild West parties, and circus parties were held in London during the 1920s. The commedia dell'arte characters enjoyed a revival, especially Harlequin and Pierrot, given a contemporary twist. Fancy dress balls became annual events at universities and colleges and a popular feature of holiday cruises.

The press called the fancy dress ball given by Carlos de Beistegui, a Mexican millionaire, in the Palazzo Labia, Venice, in September 1951, the “Party of the Twentieth Century.” The cream of international society dressed in sumptuous eighteenth-century costumes, many by French and Italian couturiers. In decline since the 1950s, fancy dress returned to fashion from the 1980s. Favorite characters in the 2000s include perennials such as monks, nuns, clowns, devils, joined by topical characters from films and TV. Themed parties are popular; Prince William of Wales celebrated his twenty-first birthday in June 2003 with an “Out of Africa” ball at Windsor Castle.

### Children's Fancy Dress

Nineteenth-century children's costumes, apart from some nursery-rhyme characters, were usually miniature versions of adult dress, reflecting the mother's taste more than the child's. By the 1920s and 1930s, however, with more occasions for fancy dress, including pageants and street carnivals, and wider social participation, children's outfits were enormously varied, based on cartoon characters and cinema heroes, animals, storybook characters, even advertisements. Many were home-made: the paper pattern firm Weldon's produced catalogs of fancy dress



“I arrived at the Sutherlands' ball impenetrably disguised as a repulsive baby boy in rompers with a flaxen wig and a ghoulish baby-face mask, then I dashed home and returned as a Sylphide in white tulle with a wreath of gardenias.”

Loelia, duchess of Westminster, 1927

patterns, and magazines suggested how to contrive costumes from everyday clothes or household furnishings.

In the early twenty-first century, dressing up is part of everyday play for three- to six-year-olds. Outfits are on sale in all toyshops and chain stores, to turn children into princesses, knights, nurses, policemen, Disney characters, or the popular fiction hero Harry Potter.

See also **Ball Dress; Masquerade and Masked Balls.**

#### BIBLIOGRAPHY

- Cooper, Cynthia. *Magnificent Entertainments: Fancy Dress Balls of Canada's Governors General, 1876–1898*. New Brunswick, Canada: Goose Lane Editions and Canadian Museum of Civilization, 1997.
- Finkel, Alicia. "Le Bal Costumé: History and Spectacle in the Court of Queen Victoria." *Dress* 10 (1984): 64–72.
- Holt, Ardern. *Fancy Dresses Described, or What to Wear at Fancy Balls*. 5th ed. London, Debenham and Freebody, 1887, 6th ed., 1896.
- Jarvis, Anthea. "'There was a Young Man from Bengal . . .': The Vogue for Fancy Dress, 1830–1950." *Costume* 16 (1982): 33–46.
- Jarvis, Anthea, and Patricia Raine. *Fancy Dress*. Aylesbury, U.K.: Shire Publications Ltd., 1984.
- Ribiero, Aileen. "The Exotic Diversion: The Dress Worn at Masquerades in Eighteenth-Century London." *Connoisseur* (January 1978): 3–13.
- Stevenson, Sara, and Helen Bennet. *Van Dyck in Check Trousers: Fancy Dress in Art and Life, 1700–1900*. Edinburgh: Scottish National Portrait Gallery, 1978.
- Westminster (Duchess of), Loelia. *Grace and Favour: The Memoirs of Loelia, Duchess of Westminster*. London: Weidenfeld and Nicolson, 1961.

Anthea Jarvis

**FANS** Though already used for many centuries in other parts of the world, fans started becoming popular in Europe in the late sixteenth century, but experienced virtual demise in the early twentieth century.

#### Sixteenth-Century Rigid Fans

There were two distinct types of rigid fan in the sixteenth century: those of exotic feathers set in a fancy handle and those of vellum or plaited palm leaf also attached to a decorative handle.

A number of portraits from 1559 to 1603 show Queen Elizabeth I (1533–1603) holding feather fans. The identifiable feathers were ostrich. Fan handles ranged from handsome silver-gilt or silver set with fabulous jewels to plain-turned wood.

A well-known 1585–1586 portrait of Queen Elizabeth I attributed to John Bettes (c. 1585–1590) and now housed in the National Portrait Gallery, London, shows her with a large ostrich feather fan set in a superb jeweled handle. The fan is given the same prominence in the

portrait as the jewelry and costume, indicating that it was valued. This is confirmed by the wardrobe inventories, which include numerous feather fans: "Item one Fanne of the feathers of the Birde of Paradise and other colored feathers thone set with sixe small starres and one great starre set with iiij or little Saphires the handle of sylver guilte." These are recorded in fascinating detail in the Stowe Inventory of 1600 and published in *Queen Elizabeth's Wardrobe Unlock'd* by Janet Arnold.

Rigid fans of vellum or plaited palm leaf were as a rule rectangular in shape and set into a handle in such a way as to look like small flags, and this is the term used to describe them.

#### Early Folding Fans

Mention the word "fan" in connection with dress and fashion, and the immediate mental image is likely to be that of the folding fan. A fashion accessory, it is easily held in the hand, whether open or closed.

The folding fan has found a niche in the popular history of fashionable dress as a pretty object that used to be carried by ladies of fashion, coupled with its reputation as a useful device in the art of flirtation. While its presence as an accessory in Western fashion has been taken for granted for over three hundred years, this is not a Western invention. It is generally acknowledged that the folding fan originated in Japan as long ago as the ninth century C.E. Its gradual dominance over the fashionable rigid feather fan of the late sixteenth and seventeenth centuries can probably be attributed to the convenience of being able to fold the fan away when not in use.

Folding fans probably made their first appearance in Europe between 1560 and 1600. It is likely that isolated examples were originally brought back by travelers or merchants as personal gifts for female friends or family and were probably treated as exotic curiosities. Proof of their existence in Japan prior to the 1560s can be seen in early Japanese paintings and manuscripts. One of the best known is the aristocratic hand scroll that illustrates *The Tale of Genji*, a romance of Japanese court life written by Lady Murasaki Shikibu in the tenth century C.E. The earliest surviving illustrated text dates from 1120 to 1130.

Not until the seventeenth century were significant quantities of folding fans imported into Europe from Japan and China. However, at some point before the end of the sixteenth century, European craftsmen appear to have taken up the challenge of making folding fans for their own market.

By the end of the seventeenth century, European fan makers had fully mastered the art of making folding fans. They used vellum or silk for the leaves and wood, ivory, tortoiseshell, mother-of-pearl, or bone for the sticks. In the sixteenth and seventeenth centuries, leather fan leaves and leather gloves were perfumed with orange water or other scents.



**Brisé Fans**

Another type of folding fan known as brisé was contemporary with folding fans. The brisé fan does not have an attached leaf. In early European examples, the entire fan consists of very wide sticks. The brisé fan shown in this entry is made of quite thick pasteboard covered in silk and elaborately decorated with delicate straw appliqué designs. Straw work of this quality may have been of Italian or south German origin. Early brisé fans have one feature in common in the shape of the sticks—each one resembles a single, stylized, curled ostrich feather. Folding feather fans do not appear until the second half of the nineteenth century.

**Seventeenth-Century European Fans**

During the seventeenth century, European folding fans improved in technique and style. The leaf would be painted in gouache. The subject matter was usually taken from classical literature or allegories. The sticks became

finer and thinner; those that supported the leaf tapered to a point at the top. The two outer sticks, known as the guard sticks, were wider at the top and more bladelike. Fan painters of this period were influenced by the masters of the early and high baroque, copying or adapting their paintings for fan leaves. Literary tastes of the era, too, were reflected in the choice of subject: classical, biblical, and—to a lesser extent—conversation scenes predominated. Both sides of a fan leaf were decorated, the front (obverse) would be fully decorated with a painted scene while the back (reverse) was usually painted with a superb rendering of familiar flowers shown as a bouquet.

**Eighteenth-Century Fans**

The eighteenth century is considered a golden age for fans. The century began with the final flourish of the heavy baroque style of Louis XIV. His death in 1715 removed his overpowering influence, and breathed new life into fashion in France and Europe. It is no surprise that

the ensuing rococo style, which predominated during the reign of King Louis XV (1715–1774), was a complete contrast. Characterized by its lightness and graceful, sinuous decoration, it was particularly well suited to decoration of fan sticks and fan leaves. Subject matter broadened to include pastoral, commemorative, and conversation themes—although classical subjects continued to be popular.

The major centers of fan production in Europe were France, Holland, England, and Italy. However, ivory fan sticks without leaves were imported in bulk from China as well as painted and plain brisé fans. The East India Company imported large quantities of fans and other goods into Europe from China in the seventeenth and eighteenth centuries. These traders would commission goods to their own specification for the European market. Such goods were designed to appeal to European rather than Asian taste, though they had a definite Asian influence, resulting in a style that became known as chinoiserie.

The most prolific fan production came from France during the eighteenth century. French influence on Eu-

ropean fashion was profound at this time. Fan leaf design was influenced by painters such as Jean-Antoine Watteau (1684–1721), François Boucher (1703–1770), and Jean-Honoré Fragonard (1732–1806).

Many fan leaves were painted on paper or vellum throughout the eighteenth century, but from the 1730s onward, an increasing number were printed. Printing created some problems in the fan-making trade as it threatened to deprive fan painters of their livelihood. It had the advantage of being quick; a printer could produce huge numbers of just one design much faster than the fan painters.

The richness and exuberance of eighteenth-century design on fans and other forms of decorative art became increasingly restrained in the last quarter of the century. The affect of neoclassicism, with its strict adherence to classical form, caused fan designs to conform to minimal decoration in the approved style.

### **Nineteenth Century**

Restrained decoration continued in the nineteenth century. Fashionable dress still retained the slim classical



### LANGUAGE OF THE FAN

In 1711, Joseph Addison (1672–1719) wrote a satirical article about fans in *The Spectator*, no. 102, including directions to present the fan as if it were a weapon. Duvelleroy published a leaflet listing various positions of the fan that a discerning young man was presumably expected to interpret.

silhouette. Fans were small to the point of invisibility. Conveniently minute, they were held in the hand or could be popped into an equally small reticule. Decoration was slight; painted flowers and a little gilding usually sufficed. Many fans at this time were brisé made of pierced ivory, bone, wood, or tortoiseshell.

Inevitably women's fashions changed, and the elegant high-waisted styles moved to a more natural waistline in the 1820s. Decoration remained delicate but grew fussier. Fans became larger, and there was a fondness for silk or net leaves with appliquéd decoration in the form of gilt paper motifs and spangles. Other types of fan leaf were of painted or printed paper. Not until the mid-nineteenth century did fan making and fan design regain the panache of the previous century.

The second half of the nineteenth century saw a gradual decline in fan making and design. In France the firm of Duvelleroy dominated the European market with quality fans and had done so since it was established in 1827. Yet, the quality of their designs flagged during the second half of the century. Fan making in England fared no better despite attempts at holding competitions. Good-quality fans appeared briefly from the 1880s following a revival of interest in fans as fashionable accessories.

But World War I and the arrival of the "Modern Woman" completed the end of the fan. By the 1920s, fans had become attractive gimmicks to be given away as advertisements by well-known department stores, restaurants, or fashion houses.

*See also Asia, East: History of Dress; Europe and America: History of Dress (400–1900 C.E.).*

#### BIBLIOGRAPHY

- Armstrong, Nancy. *A Collector's History of Fans*. London: Studio Vista, 1974.
- Arnold, Janet. *Queen Elizabeth's Wardrobe Unlock'd*. London: W. S. Maney and Sons, 1988. The Stowe Inventory, p. 325, folio 91/8.
- Bennet, A. G., and R. Berson. *Unfolding Beauty: The Art of the Fan*. Exhibition catalog. Boston: Museum of Fine Arts, 1988.
- Cust, Lionel. *Catalogue of the Collection of Fans and Fan Leaves presented to the Trustees of the British Museum by Lady Charlotte Schreiber, 1893*.

Delpierre, M., and F. Falluel, eds. *L'éventail: Miroir de la belle époque*. Exhibition catalog, Musée de la Mode et du Costume. Paris: Palais Galliera, 1985.

Gostelow, Mary. *The Fan*. Dublin: Gill and Macmillan, 1976.

Hart, Avril, and Emma Taylor. *Fans*. London: V and A Publications, 1998.

Mayor, Susan. *Collecting Fans*. London: Christies/Studio Vista, 1980.

Rhead, George Woolliscroft. *History of the Fan*. London: Kegan Paul, Trench, Trübner, and Company, 1910.

Schreiber, Lady Charlotte. *Fans and Fan Leaves*. Vol. 1: *English*; Vol. 2: *Foreign*. London: British Museum, 1888–1890.

*Avril Hart*

**FARTHINGALE.** *See Skirt Supports.*

**FASCIST AND NAZI DRESS** Already in the decade preceding the Third Reich, female fashion had become a locus of contentious debate in Germany. In reaction to the "Garçonne" style that had become popular in the post-World War I years, conservative critics railed against "degenerate" cosmetics and clothing, which they described as "jewified," "masculinized," "French-dominated," and "poisonous." They also castigated the trend mongers who pushed such tasteless, unbecoming fashions onto unsuspecting female consumers. Short hair, shorter hemlines, pants, and visible makeup—all of these were purportedly causing the moral degradation of German women.

Vituperative commentaries claimed that French fashions were unhealthy for German women, both morally and physically, and that it was imperative for German designers to establish complete independence from the nefarious French influence on female fashion. Also denounced was the dangerous American vamp or Hollywood image that young German women were foolishly imitating with penciled eyebrows, darkly lined eyes, painted red mouths, and provocative clothing. Additionally, by the mid-1920s, Berlin had become an acclaimed world center of fashion, especially for ready-to-wear women's apparel and outerwear. Highly exaggerating the percentage of Jews in the German fashion industry, diatribes in pro-Nazi publications polemicized against the "crushing" Jewish presence, which was blamed for both ruining economic opportunities for the Aryan middle class and conspiring to destroy feminine dignity by producing immoral, whorish fashions for German women. This downward spiral in female appearance, critics asserted, could be halted only with the creation of a "unique German fashion." That term, however, was never fully defined.

#### Fashion Ideology and Policy

Such reactionary, anti-Semitic, and rabidly nationalistic messages were repeated on countless occasions throughout the 1920s and early 1930s, so that by the time the Nazi Party came to power in 1933 the argument was



clear. Only German clothing, specifically Aryan-designed and manufactured, was good enough for females in the Third Reich. Racially appropriate clothing depended upon the elimination of French and, especially, Jewish influences from the German fashion industry.

To that end, an Aryanization organization named the *Arbeitsgemeinschaft deutsch-arischer Fabrikanten der Bekleidungsindustrie* (or Adefa), was established in May 1933 by several longtime German clothing manufacturers and producers. The group's aim was to systematically purge the Jews from all areas of the fashion industry. Through a combination of massive pressure, boycotts, economic sanctions, illegal buy-outs, forced liquidations, and the systematic exclusion and persecution of countless Jews, Adefa succeeded by January 1939 in ousting all Jews from the German fashion world. The *Deutsches Mode-Institut* (German Fashion Institute) was also founded in 1933, with strong backing from the Ministry of Propaganda and several other governmental agencies. Its mission was to attain fashion independence from French influence, to unify the various facets of fashion creation and fashion production in the German clothing industry, and to create a "unique German fashion" that would garner the Third Reich international acclaim and monetary rewards via its designs. Beset with internal conflicts throughout its existence and given little actual power, the German Fashion Institute never succeeded in fulfilling any of its goals.

Additionally, the Nazi state attempted to construct a female appearance that would mirror official ideology, uphold the government's autarkic economic policies, and create feelings of national belonging. This proposed female image would need to correlate to the Nazis' gender ideology, which urged women to return to their authentic role of wife and mother. Women's natural maternal instincts would thereby be satisfied, while also allowing them to fulfill the honorable duties of childbearer for the nation, significant consumer, and loyal citizen that Nazi Germany had bestowed upon them. As "mothers of the German *Volk*," women were assigned to correct the nation's sinking birthrate, guarantee the racial purity of future generations, and strengthen the economy by purchasing only German-made products. These were important tasks that required an image befitting the propaganda. For the ideal German woman, devoted to her family's well being, beauty stemmed not from cosmetics or trendy fashions, but from an inner happiness derived from her devotion to her children, her husband, her home, and her country.

The two images most often proposed and put into visual forms of propaganda were the farmer's wife in folk costume, usually referred to as *Tracht* or dirndl, and the young woman in organizational uniform. The rhetoric surrounding these two proposals advanced the "natural look" for women and condemned cosmetics and other "unhealthy vices," such as smoking and drinking, as unfeminine and un-German. Stress was placed on physical fitness and a healthy lifestyle, both of which

would facilitate a higher birthrate. Moreover, while the folk costume looked to the past and promoted an image that illuminated the Nazis' "blood and soil" ideology, and the female uniform spoke to the present and exemplified the idea of conformity over individuality, both images signified a rejection of international trends, again, as un-German. Both proposals also fit the state's anti-Semitic and anti-French agendas, as well as its "made-in-Germany" autarkic policy.

### The Dirndl Fashion

The farmer's wife, labeled "Mother Germany," was offered as one female ideal. She was the link between the bonds of German blood and soil. Her natural looks, unsullied by cosmetics, her physical strength and moral fortitude, her willingness to bear hard work and to bear many children, and her traditional dress that recalled a mythical, untarnished German past, were deified through countless exhibits, paintings, and essays. In propaganda photos, rural women usually were shown with their hair braided or pinned up in a bun, no cosmetics, surrounded by children, and beaming with an inner glow that gave no hint of the difficult work that filled their days. And what was the ideal farmer's wife wearing? According to Nazi propaganda, she should dress herself in *Trachtenkleidung*, a folk costume that reflected Germany's rich cultural heritage. Promoted as an expression of the true German-Aryan character, the age-old *Trachtendirndl*—generally comprising a dress with tight bodice and full, long skirt, a white blouse with puffed and gathered sleeves, a heavily embroidered or crocheted collar, an embellished apron, and a variety of head pieces or hats—was viewed as the most suitable example of racially pure clothing and held up as a significant symbolic metaphor for pride in the German homeland.

To promote the resurrection of the folk costume, state-sponsored *Tracht* gatherings and folk festivals cropped up everywhere, even occasionally in metropolitan areas. Girls and women were told to proudly wear dirndls for Nazi Party-sponsored occasions and historic celebrations. And, farm women were encouraged to rediscover the many attributes of *Tracht*. They were also urged to sew their dirndls from fabric they had woven themselves, while caring for their flock of children and helping with the harvest. The problem was that most of them had ceased wearing anything resembling *Tracht* on a regular basis by this time, due to its impracticality and the difficult economic straits in which so many rural families found themselves. Farm women had long ago turned to dark fabrics that showed little dirt, looser clothes that allowed for greater movement, and sleeves that did not encumber them at their work. Except for the rare special occasion or celebration, rural women had not regularly worn the traditional dirndl for decades. Also problematic, the Nazis' extensive *Tracht* propaganda did not succeed in convincing urban women to embrace the folk costume. While dressing in dirndls for certain events was



**German schoolgirls in peasant costume.** The Nazi Party urged women to embrace their cultural heritage by adopting traditional German dress, but most found such clothing impractical and continued to wear modern fashions. © HULTON-DEUTSCH COLLECTION/CORBIS. REPRODUCED BY PERMISSION.

considered fun, the majority of women living in large cities, such as Hamburg and Berlin, continued clothing themselves according to the latest international styles shown in German magazines, despite arduous efforts by some Nazis to convince them to dress otherwise.

### The Female in Uniform

As an urban alternative to the farmer's wife in *Tracht*, the Nazis offered another female ideal: that of the young German woman in uniform, a reflection of the Party's attraction to organization and militarization. Much like *Trachtenkleidung*, the uniform offered yet another visible sign of inclusion into the Nazi-constructed German racial community. It also represented order and accommodation, as well as a rejection of international trends and individuality.

As organizations quickly proliferated in the Third Reich, so did female uniforms. Whether for girls, young

women, female youths in the labor service, or female auxiliary units, once World War II began, each group had a distinct uniform or, minimally, different insignia, badges, and armbands that specified rank or branch of service. Hair was to be kept neat and away from the face, preferably in braids for young girls and a bun for adult females. Cosmetics were shunned as unnatural and unnecessary for these young women who glowed from health and love of country. Physical fitness, self-sacrifice, obedience, and loyalty to the Nazi regime and its tenets were the most important components of all organizations, whose overriding purpose was to groom a generation of racially pure, healthy, ideologically sound females to become future "mothers of the *Volk*." No individual touches, no embellishments, nothing was allowed that might detract from the symbolic significance of the requisite clothing. The uniform sartorially expressed the Third Reich's demand for unity, uniformity, conformity, and community.

Clothing females in organizational uniforms, while fairly popular when the nation was at peace, became a political problem for the government once the conflict broadened throughout Europe and additional women were needed as war-essential auxiliaries. Uniforming increasing numbers of females and placing them in positions that had been designated as “male only,” obviously upended the Nazi Party’s “separate spheres” propaganda and its gender-specific work policies of the prewar years. The state’s other concern was that extensive female uniforming would make clearly visible to the home population that the war was not going well. Furthermore, as the conflict continued and drastic textile shortages developed, some auxiliaries, who were only issued armbands indicating service affiliation in order to save material, openly complained and privately resented that they could not wear the full uniform others wore. Female auxiliaries stationed inside as well as outside of the Reich wanted, at the least, to look official as they risked their lives for the nation.

### Popular Female Fashions

The image most widely embraced by German women not only competed with these two state-sanctioned offerings, but also often glaringly conflicted with either the Party’s rhetoric or its policies. While “the natural look” was the beauty slogan pushed by Nazi stalwarts, and a “unique German fashion” was relentlessly advocated, neither was enthusiastically adopted by most women in the Third Reich. Instead, they bought the latest cosmetics, tried the newest hairstyles, and wore variations of the same fashions being worn by women in France, England, and America.

Reflecting the interests of their readership, popular magazines published articles that illustrated makeup techniques, advertised face creams, tanning lotions, and hair dyes, and offered tips on replicating the looks of Hollywood stars, such as Greta Garbo, Jean Harlow, and Katharine Hepburn. Photos in fashion journals depicted the newest styles by Parisian and American couturiers next to elegantly fashionable creations by Berlin’s best designers. Well-known German fashion schools, such as the *Deutsches Meisterschule für Mode* in Munich and the *Frankfurter Modeamt* in Frankfurt, eschewed the dirndl image in favor of international influences and female consumer desires, much to the dismay of Nazi hard-liners. And for those women who did not have the means to purchase their clothing from dress salons or department stores, sewing patterns, with which to re-create popular fashions, were widely available and affordable.

### Wartime Fashions and Rationing

On 14 November 1939, two months after the onset of World War II, the government issued the first *Reichskleiderkarte* (or Reich Clothing Card). This rationing system was designed to ensure an equitable means by which to supply the civilian population with sufficient shoes,

clothing, and textiles during the war. German Jews, deemed unworthy of receiving even minimal support, received no clothing coupons beginning in 1940. The clothing card was based on a point system, from which a recipient could not use more than 25 points in the time span of two months. Numerous other restrictions also applied. Hats were “points-free,” which meant they could be acquired without ration vouchers or clothing cards and so would become the major fashion item of the war years. Once hat supplies were depleted, and thus unobtainable for purchase, women created their own turbans and hats from fabric remnants, lace scraps, netting, and felt pieces.

The first clothing card, good for one year, allotted 100 points, but severe shortages rapidly developed in several areas, particularly shoes and cloth. Because textile and leather production increasingly was geared toward the needs of the German army, many stores were soon emptied of their reserves. Consequently, material remnants replaced leather shoe uppers, and soles were often made from cork or wood. Additionally, the government quickly discovered that its autarkic economic policy had, in part, resulted in an unsuccessful scramble for a wide variety of viable synthetics that were urgently needed to keep Germans, military and civilian, clothed. Many of the textile and leather substitutes were of poor quality and disintegrated when washed or ironed.

The second clothing card, issued in the late fall of 1940, was worth 150 points, but the additional 50 points had no real value since, by then, extreme clothing and footwear shortages had developed in several major German cities. Widely circulated government brochures urged women to “make new from old,” but a dearth of available sewing goods, such as thread and yarn, contradicted the state’s catchy mottos. Despite admonishments by those who viewed pants as unfeminine and unacceptable female attire, women increasingly wore trousers as the war dragged on and shortages continued to mount. Pants were warmer than skirts, especially once supplies of stockings and socks had been exhausted. They were far more practical for women to wear as work attire in war-related factories. And, often, they were the only clothes item in the household still in plentiful supply, with so many absent husbands and brothers serving in the armed forces.

By 1943, drastic garment and shoe shortages rendered the clothing card virtually useless in some areas of Germany. In response, civilians turned ever more frequently to the burgeoning black market, even though this was a highly punishable offense. The inability of the regime to provide adequate clothing provisions throughout the war years was met with growing resentment and overtly expressed discontent, which belied the Nazis’ depiction of a harmonious, supportive national community.

### Summary

During the Third Reich, female fashion became a topic of much discussion and dispute. Instead of a unified view



of what “German fashion” meant and a singular, consistently touted public image of the female, incongruities abounded. Additionally, no cohesive national fashion program was ever implemented successfully, despite tireless attempts by some officials. Women’s fashion, which the Nazis had hoped would be a sartorial sign of inclusion into the national community, the *Volksgemeinschaft*, instead became a signifier of disjunction. Female appearance could and did circumvent Nazi ideological tenets and state regulations, sometimes flagrantly. Concurrently, ambiguous directives laid bare the government’s obvious fear of losing both women’s support on the home front and a lucrative fashion market abroad. In the end, fashion proved to be an unsuccessful tool in defining German womanhood and citizenship, partially through the dictates of clothing and appearance. This failure exposed the limits of state power in a highly visible manner. What was propagandized in the sphere of women’s fashion had only a slight correlation to reality in Nazi Germany.

See also **Politics and Fashion**.

#### BIBLIOGRAPHY

- Bundesarchiv R3101/8646 (regarding the papers of the aryanization organization “Adefa”).
- Bundesarchiv R55/692, R55/795, and other less voluminous files (regarding “German Fashion Institute”).
- Die Dame*. One of the longest-running top contemporary German fashion magazines.
- Deicke-Mönninghoff, Maren. “Und sie rauchten doch. Deutsche Moden 1933–1945.” *Zeitmagazin*, supplement to *Die Zeit* 19 (6 May 1983): 30–40. Interesting German-language article about fashion in the Nazi period, with particular emphasis on the obvious contradictions between Nazi fashion rhetoric and reality.
- Der deutsche Volkswirt* and *Die deutsche Volkswirtschaft*. Contemporary trade journals filled with anti-Semitic essays regarding the role of Jews in the German economy.
- Guenther, Irene. “Nazi ‘Chic’? German Politics and Women’s Fashions, 1915–1945.” *Fashion Theory: The Journal of Dress, Body and Culture* 1, no. 1 (March 1997): 29–58. Overview of the subject of German fashion, with particular emphasis on the Nazi period and World War II.
- . *Nazi “Chic”?: Fashioning Women in the Third Reich*. Oxford: Berg, 2004. The only comprehensive English-language study of German fashion and the German fashion industry from World War I through the end of the Third Reich. All of the information quoted and summarized throughout this encyclopedia essay can be found in this source.
- Jacobeit, Sigrid. “Clothing in Nazi Germany.” In *Marxist Historiography in Transformation: New Orientations in Recent East German History*. Edited by Georg Iggers, 227–245. Translated by Bruce Little. Oxford: Berg, 1991. Translated overview of women’s clothing developments and relevant state policies during the Third Reich. Jacobeit has published several German-language essays pertaining to fashion in the Nazi period, which include the issue of folk costume or *Tracht*.
- Koonz, Claudia. *Mothers in the Fatherland: Women, the Family, and Nazi Politics*. New York: St. Martin’s Press, 1987. Comprehensive study of Nazi gender ideology and policies, and the role of women as “mothers of the German Volk.”
- Die Mode*. High fashion German magazine begun in 1941, two years after the onset of the war. Because of wartime paper shortages, the journal ceased publication in 1943, along with all other fashion magazines.
- Das Schwarze Korps*. Newspaper of the Nazi SS, excellent source for condemnations of female fashions and cosmetics, as well as for anti-Semitic polemics.
- Semmelroth, Ellen, and Renate von Stieda, eds. *N.S. Frauenbuch*. Munich: J. F. Lehmanns Verlag, 1934. Early Nazi anthology, the essays’ themes pertain to the role of women in Nazi ideology and policy, fashion, autarky, and consumption.
- Stephenson, Jill. “Propaganda, Autarky, and the German Housewife.” In *Nazi Propaganda 117–142: The Power and the Limitations*. Edited by David Welch, London: Croom, Helm, 1983. In-depth essay about the Nazis’ efforts to promote and implement the state’s policy of autarky as it pertained to German women.
- Sultano, Gloria. *Wie geistiges Kokain . . . Mode unterm Hakenkreuz*. Vienna: Verlag für Gesellschaftskritik, 1995. Excellent study of fashion during the Nazi period; however, sources are mostly Austrian-based, so study is focused more on Austria than on Germany.
- Völkischer Beobachter*. Pro-Nazi newspaper, excellent source for early diatribes against women’s fashions.
- Westphal, Uwe. *Berliner Konfektion und Mode: Die Zerstörung einer Tradition, 1836–1939*. 2d ed. Berlin: Edition Hentrich, 1986; 1992. Excellent examination of the early, important role of Jews in the German fashion world, and their persecution and exclusion from the fashion industry during the Third Reich.

Irene Guenther

**FASHION** According to the editorial policy of *Fashion Theory: The Journal of Dress, Body & Culture*, fashion is defined as “the cultural construction of the embodied identity.” As such, it encompasses all forms of self-fashioning, including street styles, as well as so-called high fashion created by designers and couturiers. Fashion also alludes to the *way* in which things are made; to fashion something is to make it in a particular form. Most commonly, fashion is defined as the prevailing style of dress or behavior at any given time, with the strong implication that fashion is characterized by change. As Shakespeare wrote, “The fashion wears out more apparel than the man.” There are fashions in furniture, automobiles and other objects, as well as in clothing, although greater attention is paid to sartorial fashion, probably because clothing has such an intimate relationship with the physical body and, by extension, the personal identity of the individual.

Fashion is most often thought of as a phenomenon of the Western world from the late Middle Ages onward;

but fashion-oriented behavior existed in at least some other societies and historical periods, such as Tang Dynasty China (618–907) and Heian Period Japan (795–1185). For example, at the eleventh-century Japanese court, it was a term of praise to describe something as *imamekasbi* (“up-to-date” or “fashionable”). A regular pattern of stylistic change with respect to dress and interior decoration existed in Europe by the fourteenth century. The first fashion magazine is thought to have appeared in about 1586 in Frankfurt, Germany. By the seventeenth century, Paris was the capital of European fashion, and the source of most new styles in women’s dress. By the eighteenth century, however, fashions in men’s clothing tended to originate in London.

*La mode* is the French word for fashion, and many scholars believe there is a link between *la mode* (fashion) and *la modernité* (modernity, or the stylistic qualities of what is modern). Certainly, the number of people following fashion increased greatly in the modern era, especially beginning in the nineteenth century, due to the spread of democracy and the rise of industrialization. The later nineteenth century witnessed both the mass-production of ready-to-wear clothing and also the development in Paris of the *haute couture*. Although most dressmakers then were women, some of the most famous early couturiers were men, such as Charles Frederick Worth. Other famous Paris couturiers of the twentieth century include Gabrielle “Coco” Chanel, Christian Dior and Yves Saint Laurent.

It is popularly believed that there is a great difference between high fashion and ordinary clothes, but this is not the case. Designers such as Chanel and Dior sold expensive fashionable clothes to a relatively small number of people, but their designs were widely copied by manufacturers, who sold the “knock-offs” for a fraction of the price of the originals to a much more extensive clientele. Another popular myth is that men do not wear fashion. While it is true that men’s clothing changes more slowly and subtly than women’s clothing, it, too, follows the fashion. In the 1980s, for example, Giorgio Armani designed fashionable men’s suits and jackets that had a profound influence on menswear generally. Finally, it is widely assumed that changes in fashion “reflect” societal change and/or the financial interests of fashion designers and manufacturers. Recent research indicates, however, that there also exist “internal taste mechanisms,” which drive changes in fashion even in the absence of significant social change. Particularly relevant is Stanley Lieberman’s research on fashions in children’s first names, which are clearly unaffected by commercial interests. No advertisers promote the choice of names such as Rebecca, Zoe, or Christopher, but they have become fashionable anyway.

See also **Belgian Fashion; Fashion, Historical Studies of; Fashion, Theories of; Future of Fashion; Haute Couture; Italian Fashion; Japanese Fashion; Latin Ameri-**

**can Fashion; London Fashion; Paris Fashion; Ready-to-Wear.**

#### BIBLIOGRAPHY

Lieberman, Stanley. *A Matter of Taste: How Names, Fashions and Culture Change with Time*. New Haven: Yale University Press, 2000.

Steele, Valerie. *Paris Fashion: A Cultural History*. Revised ed. Oxford: Berg, 1999.

#### Internet Resource

*Fashion Theory: The Journal of Dress, Body & Culture*. Quarterly. Oxford: Berg, 1997—. Available from <[www.fashiontheory.com](http://www.fashiontheory.com)>.

Valerie Steele

**FASHION, ATTACKS ON** While fashions in furniture and architecture have not generally been perceived as a problem, fashionable dress has been frequently criticized by clergy, philosophers, moralists, and academics for centuries. The condemnations have been numerous and varying; fashionable clothes are attacked for encouraging vanity, loose sexual morality, conspicuous consumption, and effeminacy (in men), and thus blamed for all manner of social breakdown and sexual and gender confusion. Further, the very idea of discarding clothes once they are no longer fashionable (rather than “worn out”) has been seen by some as wasteful, frivolous, and irrational. The reasons fashion has been singled out for such condemnation are important and illustrative of the way in which fashionable dress intersects with wider social debates concerning gender, class, and sexuality. Perhaps the problem has to do with the close relationship of dress to the body, which bears the weight of considerable social, moral, sexual pressure, and prohibition (see Barcan 2004 and Ribeiro 2003). Further, given the close cultural associations between a woman’s identity and her body, it is no surprise that fashion is subjected to such an onslaught of criticism: As feminists have argued, the things associated with women are likely to carry a lower social status than the things of men. This is not to say that men are exempt from criticisms concerning fashionable dress (indeed, they sometimes are), but such criticisms are less frequent in history and when they occur, it is the inappropriate nature of male interest in clothes, and fears about masculinity, that prompt such attacks.

#### Gender, Sexuality, and Morality

Understanding the historical condemnations of fashionable dress therefore necessitates an examination of attitudes toward gender, sexuality, and clothes. At the same time that women have long been associated with the making of clothes, with textiles, and with consumption, there has existed also a metaphorical association of femininity

and the very idea of fashion. According to Jones (1996, p. 35), “women had for centuries been associated with inconstancy and change,” characteristics that also describe fashion. It is also the case that as Breward (1994) and Tseëlon (1997) note, up until the eighteenth century, fashion had been considered a sign of the weakness and moral laxity of “wicked” women. Tseëlon (1997) examines how ancient myths about femininity have informed Western attitudes toward women. She points out (1997, p. 12) that between them, archetypal figures, such as Eve, inform Western moral attitudes toward women. Within Judeo-Christian teachings, from the tales of the Old Testament through the writings of the apostle St. Paul, woman has been associated with temptations of the flesh and decoration. At the heart of this attitude toward women was a fear of the body that, in Christian teachings, is the location of desires and “wicked” temptations to be disavowed for the sake of the soul. Thus the decorated (female) body is inherently problematic to Judeo-Christian morality, as Ribieiro has also argued. So too, however, is the naked or unadorned body. As Tseëlon (1997, p. 14) notes, in Judeo-Christian teachings, nakedness became a shameful thing after the Fall and, since the Fall is blamed on woman, then “the links between sin, the body, woman, and clothes are easily forged” (see also Barcan 2004).

Given its associations with sexuality and sin, it is not surprising that female clothing is the subject of heated debate amongst moralists and clergy, and that feminine dress is the object of quite vitriolic attacks. One can find particularly misogynistic diatribes on femininity and dress in the medieval writings of clergymen, as well as in the writings of later moralists of the seventeenth and eighteenth centuries. For example, Edward Cooke in 1678 wrote,

a double crime for a woman to be fashion'd after the mode of this world, and so to bring her innocence into disrepute through her immodest nakedness; because she her self not only sins against shame, but causes others to sin against purity, and at the same time, renders her self suspect. (Tseëlon 1997, p. 635)

To counter fears as to female sexuality and dress, Christianity produced “a discourse of modesty and chastity in dress” which became encoded into female sexuality (Tseëlon 1997, p. 12). Christian teachings held that redemption lay in the renunciation of decoration and modesty in dress, a moral duty born of Eve’s guilt. Thus, while men’s fashions were often highly erotic, it was women’s immodest display that was the focus of religious and moral condemnation. Only a woman could be accused of seduction in dress. While such ideas may seem almost quaint by contemporary standards, where it seems all bodies can “shamelessly” flaunt bottoms, breasts, and bellies, in fact, evidence of the continuing associations between women, seduction, and morality today can be found in contemporary culture. In rape cases, for example, women are still implicitly and explicitly criticized for wearing “sexually revealing” clothes and what a woman

wore at the time of attack can be given as evidence of her desires for sex and used as male defense in the form of “she was asking for it.” The ghost of the temptress Eve still haunts contemporary culture.

### **Class, Morality, and Social Order**

While sumptuary laws remained in place, fears about the breakdown of class distinctions were another source of anxiety for moral and social writers, particularly over the course of the eighteenth century. Here again, women’s fashion exemplifies these concerns about class, along with familiar fears about female sexuality. Sumptuary laws attempted to regulate status but, in the case of women, they also attempted to differentiate between the good, genteel wealthy woman and her “fallen” sister, the prostitute. As Emberley (1998, p. 8) notes, the hierarchy of furs and social positions created by these regulatory acts also influenced notions of sexual propriety among different classes of women. At certain times prostitutes were forbidden to wear fur to differentiate them from “respectable women.” However, it was not just sexual morality that was at stake in discourses on women and fashion. Women’s supposed love of fashion, and all that glitters and shines, has been seen as problematic to the general social and moral order. This was true in the seventeenth and early eighteenth centuries when particular fears about the spread of luxury sometimes focused on women’s supposed insatiable desires for such consumption and the threats they posed to the family, as this tract from 1740 illustrates: “although her children may be dying of hunger, she will take food from their bellies to feed her own insatiable desire for luxury, she will have her silk fashions at any cost” (Jones 1996, p. 37). Thus moral discourse gave way to other kinds of rhetoric: “sartorial offence moved from being defined as a moral transgression to being defined as a social transgression” (Tseëlon 1997, p. 16). While the former was considered indicative of character flaw, the latter indicates a lack of gentility and education and civility. Thus, while moral transgression through clothing was a matter for both sexes, a woman might transgress moral codes in more ways than a man. By being too highly decorated she might be seen to have fallen prey to the sin of vanity (Jones 1996, p. 36).

### **Masculinity and Morality**

While men of aristocratic birth were at least as equally decorated as women, for much of the early modern period right through to the eighteenth century (and indeed, beyond, if one includes military dress), this simple fact did not dilute the association of fashion with femininity. Indeed, when male peacocks were criticized it was often on the grounds of “effeminacy,” for showing too great an interest in fashion was deemed “inappropriate” to masculinity. Sometimes this criticism was leveled on the grounds that male interest in fashion transgressed the rightful division of the genders. At other times, effeminacy was seen as problematic to the image of a nation.



The equation of effeminacy in male attire with the diminution of national interests can be seen in Elizabethan England: In the sermon “Homily Against Excess,” which Queen Elizabeth I ordered to be read out in churches, such associations are described as follows, “yea, many men are become so effeminate, that they care not what they spend in disguising themselves, ever desiring new toys, and inventing new fashions. . . . Thus with our fantastical devices we make ourselves laughing-stocks to other nations” (Garber 1992, p. 27).

As Garber notes, effeminacy here does not mean homosexuality (as it often does) but “self-indulgent” or “voluptuous” and therefore close to “womanly” things. Criticism is leveled at the money, time, and energy devoted by the effeminate man to the “feminine” and “trivial” frivolities of fashion. Similar criticism was directed at the “Macaroni” style (as in the rhyme “Yankee Doodle Dandy”) that was popular among young aristocratic men of the eighteenth century. Macaronis appeared in the English lexicon of 1764 to describe ultra-fashionable young men of noble birth. It was a rather “foppish” style, Italianate and Frenchified, and was criticized on the grounds that this gentleman had “become so effeminate and weak, he became unable to resist foreign threats and might even admire European tyranny” (Steele 1988, p. 31). Men have, therefore, not been immune to sartorial criticism, because it was thought that they should be “above” fashion. However, while moralists and clergymen might hope to dissuade men from decoration, historical evidence illustrates that they, too, have been under the sway of fashion.

### Fashion as Irrational

Over the nineteenth century, as fashionable clothing became more widespread, moving from the aristocracy to the new bourgeois classes as part of a more general opening up of consumption, other problems associated with fashion were singled out for criticism. For some, fashionable clothing was indicative of wastefulness associated with new forms of consumption. One key figure in this line of attack is Thorstein Veblen, whose *Theory of the Leisure Class*, first published in 1899, has remained a classic study of fashionable dress in late Victorian times and whose central theoretical tenants are still very much alive in contemporary critiques of consumption. Veblen argues that the newly emerging bourgeoisie express their wealth through conspicuous consumption, conspicuous waste, and conspicuous leisure. Dress is a supreme example of the expression of pecuniary culture, since “our apparel is always in evidence and affords an indication of our pecuniary standing to all observers at the first glance” (Veblen 1953, p. 119). Fluctuating fashions demonstrate one’s wealth and transcendence from the realm of necessity. However, what motivates fashion change is that wastefulness is innately offensive and this makes the futility and expense of fashion abhorrent and ugly. He suggests that new fashions are adopted in our attempt to

escape this futility and ugliness, with each new style welcomed as relief from the previous aberration until that too is rejected. According to Veblen, women’s dress displays these dynamics more than men’s since the only role of the bourgeois lady of the house is to demonstrate her master’s ability to pay, his pecuniary strength to remove her entirely from the sphere of work. The Victorian woman’s dress was also an important indicator of vicarious leisure since she wore clothes that made her obviously incapable of work—elaborate bonnets, heavy and elaborate skirts, delicate shoes, and constraining corsets—testimony to her distance from productive work. Veblen condemns all these traits of fashionable dress, not just because they characterize women as men’s chattel, but also because this fashionability is inherently irrational and wasteful. He calls for dress that is based on rational, utilitarian principles, and his ideas are closely aligned to the principles of many dress reformers (Newton 1974).

### Ugly, Futile, and Irrational: The Dress Reform Critiques of Fashion

Veblen was not alone in his condemnation of the fashions of his day. Numerous dress-reform movements emerged in the nineteenth century attacking fashionable dress. These movements were diverse and motivated by different concerns—social, political, medical, moral, and artistic—with some more progressive than others (Newton 1974; Steele 1985). For feminist dress reformers, the way in which narrow shoulders, tight waists, and expansive and awkward petticoats constrained the locomotion of the female body was a real political problem. However, more conservative medical discourses similarly attacked the corset for the way it constrained the reproductive organs, thus damaging women’s reproductive capacities and preventing her from performing her “natural” duties. Indeed, the corset has excited considerable controversy, stimulating intense debate and outright condemnation: For some it is an instrument of physical oppression and sexual objectification (Roberts 1977; Veblen 1953 [1899]), for others, it is a garment asserting sexual power (Kunzle 1982; see also Steele 1988).

While women’s dress, in particular, was singled out for criticism by these reform movements, men’s dress, with its tight collars, fitted waistcoats and jackets, was also criticized by those, such as Flügel, associated with the men’s dress reform movement. The dress of both men and women was seen by some to be “irrational” in that it contorted the body into “unnatural” shapes and was driven by the “crazy” rhythms of fashion considered to be not just archaic to a scientific age, but wasteful and unnecessary. For example, “aesthetic” dress of the late nineteenth century challenged the artificial constrictions of the fashions of the day with a new kind of dress for men and women that was free flowing and more “natural.” At the same time health and hygiene campaigns often singled out women’s dress as unhealthy or unhygienic: It was said that corsets damaged the spleen and internal organs,

particularly the reproductive organs, and the long petticoats picked up the mud, debris, and horse manure that were a constant feature of city streets in the nineteenth century (Newton 1974).

While fashion may be subject to much less criticism today, and no equivalents to the health and hygiene campaigns of the nineteenth century can be found, remnants of some criticisms linger in contemporary commentaries. For example, fashionable dress is still sometimes considered irrational and ugly, especially among intellectuals. Like Veblen, the contemporary philosopher Jean Baudrillard (1981, p. 79) condemns fashion as irrational and ugly, arguing that

Beauty (“in itself”) has nothing to do with the fashion cycle. In fact, it is inadmissible. Truly beautiful, definitely beautiful clothing would put an end to fashion. . . . Thus, fashion continually fabricates the “beautiful” on the basis of a radical denial of beauty, by reducing beauty to the logical equivalent of ugliness. It can impose the most eccentric, dysfunctional, ridiculous traits as eminently distinctive.

Wilson (1987) takes issue with Veblen and Baudrillard’s account of fashion as wasteful and futile since both assume the world should be organized around utilitarian values; “there is no place for the irrational or the nonutilitarian; it was a wholly rational realm” (Wilson 1987, p. 52). A further problem with Veblen’s and Baudrillard’s accounts, according to Wilson, concerns their causal account of fashion change. The idea that fashion is constantly changing in an attempt to get away from ugliness and find beauty is reductive and over-deterministic. Both fail to acknowledge its ambivalent and contradictory nature, as well as the pleasures it affords, and their critique “grants no role to contradiction, nor for that matter to pleasure” (1987, p. 53).

### Conclusion

Dress is still, perhaps, accorded less status than furniture, architecture, and other decorative commodities, which are similarly driven by fashion. There is something so intimate, sexual, and moral about what we hang at the margins of our bodies that makes dress susceptible to a kind of criticism that does not accompany the other objects we use. However, despite the fact that men and women wear fashionable dress, it is not considered a matter of equal male and female concern. Associations of fashion with femininity linger, and women’s supposed “natural” disposition to decorate is still considered “trivial” and “silly,” thus leaving women open to greater moral condemnation. While such ideas seem to be less obvious today, the lower status accorded to fashionable dress is evident in the sorts of criticism leveled at women, such as “mutton dressed up as lamb” (of which there is no equivalent term for men), and “fashion victim,” (usually denoting the woman who is a “slave” to her wardrobe). As these phrases suggest, fashion still comes in for moral judgment and criticism.

See also **Dress Reform; Gender, Dress, and Fashion; Politics and Fashion.**

### BIBLIOGRAPHY

- Barcan, R. *Nudity: A Cultural Anatomy*. Oxford, U.K. and New York: Berg, 2004.
- Baudrillard, J. *For a Critique of the Political Economy of the Sign*. St. Louis, Mo.: Telos, 1981.
- Breward, C. *The Culture of Fashion*. Manchester, U.K.: Manchester University Press, 1994.
- Garber, M. *Vested Interests: Cross Dressing and Cultural Anxiety*. London: Penguin, 1992.
- Jones, J. “Coquettes and Grisettes: Women Buying and Selling in Ancien Regime Paris.” In *The Sex of Things: Gender and Consumption in Historical Perspective*. Edited by V. de Grazia and E. Furlough. Berkeley: University of California Press, 1996.
- Kunzle, D. *Fashion and Fetishism: A Social History of the Corset, Tight-Lacing and Other Forms of Body-Sculpture in the West*. Totowa, N.J.: Rowan and Littlefield, 1982.
- Newton, S. M. *Health, Art and Reason: Dress Reformers of the 19th Century*. London: John Murray Ltd., 1974.
- Roberts, H. “The Exquisite Slave: The Role of Clothes in the Making of the Victorian Woman.” *Signs* 2, no. 3 (1977): 554–569.
- Steele, V. *Paris Fashion: A Cultural History*. Oxford, U.K.: Oxford University Press, 1988.
- Tseilon, E. *The Masque of Femininity*. London: Sage, 1997.
- Veblen, Thorstein. *The Theory of the Leisure Class: An Economic Study of Institutions*, (1899). New York: Mentor, 1953.
- Wilson, E. *Adorned in Dreams: Fashion and Modernity*. London: Virago, 1985. Reprint, Piscataway, N.J.: Rutgers University Press, 2003.

Joanne Entwistle

**FASHION, HISTORICAL STUDIES OF** The earliest books on fashion history published in Europe date back to the Renaissance and the early modern period. Between 1520 and 1610, over two hundred books on dress were published in Germany, Italy, France, and Holland. These little books, designed for wealthy consumers, contained wood-engraved plates and minimal text, often in Latin and were focused on contemporary clothing. Curiosity about the foreign and the strange was as intense as ignorance was rife and publications contained fantasized images of the noble savage (the Peruvian, the Florida Indian, the African) set against plates of the fashionable clothes of European aristocracy and the dress of merchants, peasantry, and tradesmen. Between 1760 and 1820 interest in fashion and dress from wealthy consumers encouraged the publication of large folio-size costume books featuring hand-colored, etched copper plates and the new color printing technique of aquatint and, from the 1830s, lithography. Romanticism suffused all these luxury publications, with their emphasis on illus-

tration with brief text, now no longer in Latin. Thomas Jefferys's ambitious four volumes, *Collection of the Dresses of Different Nations, Ancient and Modern* (1757 and 1772), covered dress of the entire known world, including "Old English Dresse after the Designs of Holbein, Vandyke, Hollar and Others." His view of women's fashions was that they were simply "a Decoration of Beauty, and an encitement to Desire."

#### "Antiquarian" Research into Fashions

A widening fascination with classical dress of ancient Greece and Rome in France led to Michel-François Dandré Bardon's *Costume des anciens peuples* of 1772 and André Lens's *Costume des peuples de l'antiquité* in 1776. These helped to fuel the eventual development of neoclassical fashions. The Gothic Revival too encouraged a wave of European interest in medieval dress history. These books provided "authentic" details of "Gothic" dress for dress-makers as well as artists, architects, and enthusiasts of fancy dress. Interest lasted into the nineteenth century and indeed beyond. The central dress historian of this period in England was Joseph Strutt, an artist and antiquarian. His major work was *A Complete View of the Manners, Customs, Arms, Habits etc. of the Inhabitants of England* (1774, 1775, and 1776) and *Complete View of the Dress and Habits of the People of England*, 1796 and 1799, which covered the Middle Ages through to the seventeenth century, using literary sources, and medieval manuscripts and monuments.

#### Dress of the Orient

The passion for an exotic, fantasy "Orient" encompassed Turkey, Arabia, India, China, and finally Japan, and fueled the imaginations of the makers of fashions and fancy dress throughout the eighteenth and nineteenth centuries. The vogue for Chinese decoration and chinoiserie infiltrated deeply into court and middling circles in Europe from 1680 to 1780 and much artistic and fashion inspiration was drawn from costume books of the period. Jean Baptiste Joseph Breton de la Martinière's *La Chine en miniature, . . . costumes, arts et métiers de cet empire*, with its seventy-four plates, was published in Paris, in 1811–1812. William Miller's *The Costume of China* of 1800 was reprinted in 1805, but with new plates drawn by William Alexander, official draftsman to the embassy of Earl Macarthy from 1792 to 1794 to China.

The elitist fashion vogue for *Turquerie* styles drew on plates from costume books such as William Miller's *The Costume of Turkey* of 1804 and, in 1814, on Jean Baptiste Joseph Breton de la Martinière's *L'Égypte, et la Syrie au moeurs, usages, costumes et monuments des égyptiens, des arabes, et des syriens*. Indian women became exoticized and sexualized, while modified Indian styling also filtered in to European fashionable dress. François Baltasar Solvyns's *Costumes of Indostan* was published in Calcutta in 1798–1799 and in London in 1804. Books with plates of Japanese dress were disseminated from the early nine-

teenth century. Thus, well before the tidal wave of publications of the 1880s and 1890s, Breton de la Martinière's *Le Japon, ou moeurs, usages, et costumes des habitons de cet empire d'après les relations récentes de Krusenstern, Landsdorf, Titzing* was published in Paris by A. Nepveu in 1818.

#### Rural Europe

From the early nineteenth century a wave of descriptive books on the dress of European peasantry also exerted an influence on fashionable and fancy dress. Utopian notions and Romanticism turned to visions of a rural Europe peopled by a healthy peasantry in picturesque clothing. These costume books are informative and charming but also reveal period imperialist, gender, and stereotypic race and class prejudice. *The Costumes of the Hereditary States of the House of Austria* of 1804, for example, contains both sweet images of romanticized peasant women from all over central, southern, and eastern Europe set against textural and visual anti-Semitism in coverage of Polish Jewish dress. Twenty-three major French works were published between 1810 and 1830 on Breton peasant dress alone, such was the interest.

#### Books of Historical Dress for Theater and Fancy Dress

The role of historians undertaking research for theater costume and fancy dress purposes has been central to the development of fashion history since the eighteenth century. Thomas Hope's *Costumes of the Ancients* in 1809 was planned as a designer's dictionary, for "the theatrical performer, the ornamental architect and every other artist to whom the knowledge of classical costume is necessary." James Robinson Planché, the major early nineteenth-century British costume historian, not only republished volumes of Strutt but made the first attempt to design historically accurate costumes for a Shakespearean play in 1823. His 1834 *History of British Costume* became the first really popular costume history book, republished in cheaper versions in 1849 and in 1893.

#### Nineteenth-Century French Histories

In France, Camille Bonnard's *Costume historique des XIIe, XIIIe, XIVe et XVe siècles*, published in Paris by A. Levy fils in 1829–1830, became an important Pre-Raphaelite costume source book. Paris produced, too, Le Comte Horace de Viel-Castel's *Collection des costumes, armes, et meubles*, in four volumes, 1827–1845. Paul Lacroix's long list of publications includes his ten-volume *Costumes historiques de France* published from 1852. Laver declared that Raphael Jacquemin's *Iconographie du costume du IVe–XIXe siècle*, produced in three folio volumes in Paris between 1863 and 1869, was "superb and scholarly." In 1881, Augustin Challamel produced his *Histoire de la mode en France* translated into English and published in 1882 by Sampson Low, Marston, Searle and Rivington. In 1888, Firmin Didot published Auguste Racinet's famous and expensively produced six-volume *Le costume historique*.



### Fashion, Sociology, and Psychology

While these early generations of descriptive dress history studies, all by male writers, laid the foundation stones of fashion history, it took Thorstein Veblen's *Theory of the Leisure Class* (1899) and George Simmel's *Philosophie der Mode* (1905) to launch lasting theoretical debate about the cultural meanings behind fashion development and the causes of variation in consumption patterns. Interestingly, however, their theories made virtually no impact on fashion history until at least sixty years after their publication. A selection drawn from the many new dress history books of the 1900 to 1930 period, including George Clinch's book *English Costume, from Prehistoric Times to the End of the Eighteenth Century*, for example, of 1909, showed little change from established antiquarian approaches. *Modes and Manners of the Nineteenth Century* by Oscar Fischel and Max von Boehn is a four-volume German study of fashion from the 1790s onward, first published in 1909, which used a lively choice of cartoons as well as the usual fashion plates. Hilaire Hiler's *From Nudity to Raiment* in 1929 took a painter's interest in the field. With M. Meyer, he produced one of two meticulous costume bibliographies of the 1930s. Theirs was a *Bibliography of Costume*, published by H. W. Wilson in 1939. This followed René Colas's *Bibliographie générale du costume et la mode* of 1933. These carefully researched books were basically descriptive with little detailed study of garments.

### Early Object-Centered Dress History

Elisabeth McClellan's unusually progressive study of 1904, however, *Historic Dress in America*, took markedly different approaches. It examined clothing worn in Spanish, French, English, Dutch, Swedish, and German settlements in early North America. This study, little discussed in the early 2000s, is remarkable on several counts. First it was written by a woman; and second, the author worked from a strongly object-based approach, declaring that "some relics of by-gone days have been preserved intact and placed in our hands for the preparation of this book—veritable documents of history on the subject of dress in America" (McClellan 1904, p. 5). Exceptional for studies of this period, hers took care to include everyday working clothes, such as her "Woman in Typical Working Dress 1790–1800" drawn from an original garment from the Stenton house in Philadelphia.

The second, major object-focused study is now a forgotten book by the painter Talbot Hughes, whose dress collection was accepted by the Victoria and Albert Museum in 1913. In that same year, interested in dress history for his own genre paintings, he published his *Dress Design—an account of Costume for Artists and Dressmakers—Illustrated by the author from old examples*. The book is illustrated with little line drawings, photographs, and even cutting patterns of surviving clothes from the mid-sixteenth century through the 1870s (Taylor, *Establishing Dress History*, pp. 47–49). Thalassa Cruso, the first cos-

tume curator at the Museum of London, basically a social history museum, also pioneered object-based fashion history. Her ideas were published in the museum's first dress catalog in 1933. She was probably the first woman costume curator to fuse theories related to issues of fashion production and consumption with close garment study.

### The Psychology of Dress

The psychology of dress opened up further debates about the functions of dress and fashion. These debates were taken up by Frank Alvah Parsons in New York, whose study of that name was published in 1920, by J. C. Flügel, in his study *The Psychology of Clothes* of 1930, and in the work in England of the dress historians C. W. Cunnington and James Laver from the 1930s.

Thus by 1933, three diverging approaches to the study of fashion were in place—the descriptive, somewhat social history-oriented methods; object-focused research conducted largely but not exclusively by women curators; and the more detached, theoretical approaches developed by male specialists. These divisions remained firmly in place for another fifty years.

### The Men Dress Historians

Drawing on Flügel, Dr. C. W. Cunnington, a medical doctor, and James Laver, Keeper of Prints and Drawings at the Victoria and Albert Museum, both took a deep interest in fashion history and in issues of women, style and sexuality, and fashion. Between 1931 and the late 1960s, they published books that successfully opened dress history to a wider popular audience. James Laver produced over fifty books dealing with art, prints, social, theater, and dress history. He understood well the problem of explaining the ephemeral character of fashion to those who still continued to dismiss the field as culturally worthless, defining fashion as "a spear head of taste, or rather it is a kind of psychic weathercock which shows which way the wind blows" (J. Laver 1945, p. 211). Laver's very real understanding of the creative and commercial processes of fashion were coupled with a detailed interest in social history and a profound knowledge of dress history. He died in 1975. By then, through lectures and radio and TV appearances, he had become the popular, articulate public face of British dress history. The Cunningtons' most lasting work was based on object analysis, though C. W. Cunnington also wrote up his own theories on women's motivation for wearing fashionable dress, now considered outdated (Taylor, *Establishing Dress History*, pp. 51–57).

### The Women Fashion Historians

It is in this period too that women historians finally make their mark. It is significant within the history of the development of feminine approaches that they chose object-based approaches, much like those of Elisabeth McClellan and Thalassa Cruso. Directional, object-centered publi-

cations in the 1940s by Doris Langley Moore and from the 1950s onward by Anne Buck created methodological approaches that have remained lastingly valid.

Doris Langley Moore, whose personal costume collection formed the basis of the now famous Museum of Costume in Bath, published two much-neglected books: *The Woman in Fashion* of 1949 and *The Child in Fashion* of 1953. Using her own collection, these explored fashionable dress from 1800 on photographed on live models, (her famous actress and theater friends and their children) with carefully correct period hairstyles and in period settings. While this method of illustration is no longer used because of the danger to the garments, both her books contain directional debate that sought to explode popular sartorial myths, such that Regency dress was transparent and that Victorian women had tiny waists. Attacking Flügel and C. W. Cunnington for an overemphasis on women's sexuality as the most significant motivation for wearing fashionable dress, Langley Moore addressed the social and cultural codes hidden within fashionable dress, avoiding the trap of class generalization that Fischel and von Boehn and Cunnington fell into.

C. W. Cunnington's wife, Phillis, also a doctor, who had worked with him on the famous *Handbook* series, began, after his death in 1961, to collaborate with new researchers. Thus, she began producing a now-famous and well-reputed series of dealing with specialist dress histories, including her seminal study *Costume for Births, Marriages and Deaths*.

Anne Buck, as the first Keeper of the Gallery of English Costume at Platt Hall, from 1947 to 1972 quickly established an object-based approach that emphasized both the social function of dress and professional museological methods of conservation and display of clothing artifacts. This exerted a seminal influence in the dress history world after the 1950s. Her meticulously researched publications fused close analysis of clothing examples with archival study and are classic examples of "good practice." Her range of special interests included smocks and English lace making. In 1961 she published her *Victorian Costume and Costume Accessories* and in 1965, *Children's Costume in England from the Fourteenth to the end of the Nineteenth Centuries* (republished in 1996) and *Dress in Eighteenth Century England* of 1979. Once retired and with more time for archival research, she published a series of articles that incorporated new consumption approaches. That Buck centered her work on object-based approaches was rare enough, but rarer still is that her enthusiasms and expertise embraced the clothes of all levels of society.

Another group of women fashion historians developed the work of Talbot Hughes, studying surviving clothing through analysis of the cut and making up garments and specializing in producing cutting patterns of period clothing. Nora Waugh taught theater wardrobe

design at the Central School of Arts and Crafts in London. She published *Corsets and Crinolines* in 1954, *The Cut of Men's Clothes* in 1964, and *The Cut of Women's Clothes* in 1969. Based on patterns drawn up from surviving garments, Waugh added details of style history and making up details but was vague on many sources.

This methodology was further developed by Janet Arnold and explained in her *Handbook of Costume* of 1973. Arnold spent a lifetime exploring dress history through meticulous analysis of the cut of male and female fashionable dress. She was frequently called on by museums on both sides of the Atlantic to advise on dating reconstructing damaged period clothing and often advised on film and theater productions.

### **New Approaches from the 1980s**

From the 1980s, a great range of more open-minded theoretical approaches, derived from other academic fields, transformed the entire field of fashion history study. These included analysis of the semiotics of fashion, new approaches to the coded body (fashionable, subcultural, and male/female, and gay/lesbian). Elizabeth Wilson's work is cited by many as seminal to the acceptance of "fashion" as a legitimate field of study. Wilson's *Adorned in Dreams* of 1985 (revised in 2003), which included a celebration of the enjoyment that women can derive on their own terms from fashionable dress, was a turning point. From the 1980s, interest in fashion history blossomed through new critical approaches flowing out from the developing fields of cultural and gender studies. These have had a dramatic impact on fashion history research as reflected since 1997 in the pages of *Fashion Theory: The Journal of Dress, Body and Culture*, founded and edited by Valerie Steele.

### **Object-Focused Study**

Older, established fashion history methodologies have had to respond to these fresh approaches and have held their ground. Naomi Tarrant, of the Royal Museums of Scotland, Edinburgh, in her 1994 book, *The Development of Costume* stressed her conviction that artifact-based approaches remained a vital counterweight to theoretical analysis. Museum fashion history exhibitions in North America and across Europe spawned significantly new types of glossy yet informative and critical shows and catalogs, such as Richard Martin's and Harold Koda's study of orientalism and fashion at the Costume Institute of the Metropolitan Museum of Art in 1994. *Radical Fashion*, curated by Claire Wilcox at the Victoria and Albert Museum in London, placed contemporary radical couture and conceptual dress in front of the British public for the first time. Other "designer" exhibitions and catalogs have sparked debate about an overly close relationship between museums and global fashion companies through much-needed financial sponsorship. Some suggest that as the fashion world itself relies more and more on celebrity product endorsement, fashion history too must respond

to the commercial and cultural realities that surround the fashion world in the early 2000s.

### Studies on Fashion Designers

The history of the haute couture industry is thus subject to more intensive debate than ever before and studies now move far beyond the usual coffee-table books. Alexandra Palmer's *Couture and Commerce*, for example, is a seminal example of these new approaches. This beautifully illustrated study details the processes of the designing, making, and retailing of Paris couture clothes, as well as their social consumption and cultural meanings to Toronto society in the 1950s.

### Conceptual Fashion

The advent of conceptual fashion has triggered new analytical debate in studies by, for example, Caroline Evans, Jennifer Craik, Richard Martin, Joanne Entwistle, and Christopher Breward. The journal *Fashion Theory*, too, has been at the forefront of these developments. Breward writes that “the self constructed role of radical fashion design seems to be to present a very specialized commentary on the vicissitudes of contemporary taste and aesthetics, everything to do with internal fashion culture debate about genre, hierarchy, presentation and style” to be “showcased rather than sold” (Breward 2003, p. 229). Finally, Caroline Evans's seminal 2003 study *Fashion at the Edge* debates conceptual and couture fashion from the 1990s, using fashion development as a tool through which to “pathologize contemporary culture” and to examine its characteristics of “alienation and nihilism.” She discusses conceptual and couture fashion as “a form of catharsis, perhaps a form of mourning and a coping stratagem. . . [It is] the dark side of a free market economy, the loosening of social controls, the rise of risk and uncertainty as key elements of ‘modernity’ and ‘globalization.’ She writes, “The dark history of twentieth century seems finally to have caught up with fashion design” (Evans 2003, p. 308–309).

Thus, fashion studies and fashion history are fields that positively incorporate critical approaches built around anthropology, psychology, history of technology, business, sociology, material culture, and cultural studies. The best examples of good practice are also finally filled with impressive color plates and intelligently fuse object and theory. It is serious debates such as these that confirm the fundamental and central cultural place of fashion within society and that clarify the future directions for the field of fashion history and fashion studies.

See also **Ancient World: History of Dress; Appearance; Fashion, Theories of.**

### BIBLIOGRAPHY

The sections on the history of fashion publications are drawn from chapters 1 and 2 of Lou Taylor, *Establishing Dress History*, 2004, Manchester University Press, with their kind permission.

- Arnold, Janet. *A Handbook of Costume*. London: Macmillan, 1973.
- Bertin, Célia. *Paris à la Mode: A Voyage of Discovery*. London: Gallancz, 1956.
- Breward, Christopher. *The Hidden Consumer: Masculinities, Fashion and City Life 1860–1914*. Manchester, U.K.: Manchester University Press, 1999.
- . *Fashion*. Oxford: Oxford University Press, 2003.
- Buck, Anne. *Victorian Costume and Costume Accessories*. London: Jenkins, 1961.
- . *Thomas Lester, His Lace and the East Midlands Industry 1820–1905*. Bedford: Ruth Bean, 1981.
- Craik, Jennifer. *The Face of Fashion: Cultural Studies in Fashion*. London and New York: Routledge, 1994.
- Cunnington, Cecil Willett. *English Women's Clothing in the Nineteenth Century*. London: Faber, 1937.
- . *Handbook of English Costume in the Eighteenth Century*. London: Faber, 1957.
- . *Handbook of English Costume in the Nineteenth Century*. London: Faber, 1959.
- Cunnington, Phillis. *Costume for Births, Marriages and Deaths*. London: Adam and Charles Black, 1972.
- Entwistle, Joanne, and Elizabeth Wilson, eds. *Body Dressing*. Oxford: Berg, 2001.
- Evans, Caroline. *Fashion at the Edge: Spectacle, Modernity and Deathliness*. New Haven, Conn., and London: Yale University Press, 2003.
- Evans, Caroline, and Minna Thornton. *Women and Fashion: A New Look*. London: Quartet, 1989.
- Davis, Fred. *Fashion Culture and Identity*. Chicago: University of Chicago Press, 1994.
- Flügel, John Carl. *The Psychology of Clothes*. London: Hogarth Press Institute of Psycho-Analysis, 1930.
- Habitus Praecipuorum Populorum tam Virorum quam Feminarum Singulari Arte Depicti*. Nuremberg, Germany: Hans Weigel, 1577.
- Langley Moore, Doris. *The Woman in Fashion*. London: B. T. Batsford, Ltd., 1949.
- . *The Child in Fashion*. London: B. T. Batsford, Ltd., 1953.
- Laver, James. *Taste and Fashion*. London: Harrap, London, 1937. Reprint, London: G. G. Harrap, 1945.
- . *Costume and Fashion: A Concise History*. London: Thames and Hudson, Inc., 1982. Reprint, New York: Thames and Hudson, Inc., 1995.
- Martin, Richard, and Harold Koda. *Orientalism and Fashion: Visions of the East in Western Dress*. New York: Metropolitan Museum of Art, 1994.
- McClellan, Elisabeth. *Historic Dress in America, 1607–1800*. Philadelphia: George W. Jacobs and Company, 1904.
- Palmer, Alexandra. *Couture and Commerce: The Transatlantic Fashion Trade in the 1950s*. Vancouver, Canada: University of British Columbia Press, 2001.
- Parsons, Frank Alvah. *The Psychology of Dress*. New York: Doubleday, Page; London: B. T. Batsford, Ltd., 1920.
- Planché, J. R. *History of British Costume*. London: George Bell, 1893.



- Steele, Valerie. *Paris Fashion: A Cultural History*. New York and Oxford: Oxford University Press, 1988.
- . *The Corset: A Cultural History*. New Haven, Conn., and London: Yale University Press, 2001.
- Strutt, Joseph. *A Complete View of the Manners, Customs, Arms, Habits etc. of the Inhabitants of England* (1774, 1775, and 1776) and *Complete View of the Dress and Habits of the People of England*, 1796 and 1799.
- Tarrant, Naomi. *The Development of Costume*. London: Routledge, 1994.
- Taylor, Lou. *The Study of Dress History*. Manchester, U.K.: Manchester University Press, 2002.
- Troy, Nancy. *Couture Culture: A Study in Modern Art and Fashion*. Cambridge, Mass., and London: MIT Press, 2002.
- Veblen, Thorstein. *Theory of the Leisure Class*. New York: Macmillan, 1899.
- Wilcox, Claire. *Radical Fashion*. London: Victoria and Albert Museum, 2001.
- Wilson, Elizabeth. *Adorned in Dreams: Fashion and Modernity*. New ed. London: I. B. Tauris, 2003.

Lou Taylor

**FASHION, THEORIES OF** Fashion involves change, novelty, and the context of time, place, and wearer. Blumer (1969) describes fashion influence as a process of “collective selection” whereby the formation of taste derives from a group of people responding collectively to the zeitgeist or “spirit of the times.” The simultaneous introduction and display of many new styles, the selections made by the innovative consumer, and the notion of the expression of the spirit of the times provide impetus for fashion. Central to any definition of fashion is the relationship between the designed product and how it is distributed and consumed.

***Fashion systems model.*** The study of fashion in the twentieth century has been framed in terms of a fashion systems model with a distinct center from which innovations and modifications radiate outward (Davis 1992). Designers work from the premise of one look, one image for all, with rules about hem lengths and what to wear with what. In this model, the fashion-consuming public develops from an innovative central core, surrounded by receptive bands of fashion consumers radiating outward from the center.

Within this system innovation can originate from a select grouping of designers, such as Christian Dior who introduced the “New Look” in 1947. Influential factors can range from individual tastes, to current events, to marketing and sales promotions. The ultimate qualifier of the fashion systems model is the scope of influence, urging, even demanding, one look for all. The element of conformity is instrumental.

***Populist model.*** An alternative model to the fashion systems model is the “populist” model. This model is characterized as polycentric, where groups based upon

differences of age, socioeconomic status, location, and culture create their own fashion. Such groups might include teenagers in a certain school or senior citizens in a retirement community. Polhemus (1994) describes “styletribes” as a distinct cultural segment that generates a distinctive style of dress and decoration. Such “styletribes” may create their own looks from combining existing garments, creating their own custom colors by tie-dyeing or painting, mixing and matching from previously worn and recycled clothing available in thrift shops and vintage markets. They are not so concerned with one style of dressing as with expressing themselves, though there is an element of conformity that derives from the processes used and the resulting social behavior. Polhemus reflects that such “styletribes” have flourished at “precisely that time in history when individuality and personal freedom have come to be seen as the defining features of our age” (p.14).

### The Flow of Fashion

The distribution of fashion has been described as a movement, a flow, or trickle from one element of society to another. The diffusion of influences from center to periphery may be conceived of in hierarchical or in horizontal terms, such as the trickle-down, trickle-across, or trickle-up theories.

***Trickle down.*** The oldest theory of distribution is the trickle-down theory described by Veblen in 1899. To function, this trickle-down movement depends upon a hierarchical society and a striving for upward mobility among the various social strata. In this model, a style is first offered and adopted by people at the top strata of society and gradually becomes accepted by those lower in the strata (Veblen; Simmel; Laver). This distribution model assumes a social hierarchy in which people seek to identify with the affluent and those at the top seek both distinction and, eventually, distance from those socially below them. Fashion is considered a vehicle of conspicuous consumption and upward mobility for those seeking to copy styles of dress. Once the fashion is adopted by those below, the affluent reject that look for another.

***Trickle across.*** Proponents of the trickle-across theory claim that fashion moves horizontally between groups on similar social levels (King; Robinson). In the trickle-across model, there is little lag time between adoption from one group to another. Evidence for this theory occurs when designers show a look simultaneously at prices ranging from the high end to lower end ready-to-wear. Robinson (1958) supports the trickle-across theory when he states that any social group takes its cue from contiguous groups in the social stratum. King (1963) cited reasons for this pattern of distribution, such as rapid mass communications, promotional efforts of manufacturers and retailers, and exposure of a look to all fashion leaders.

***Trickle up.*** The trickle-up or bubble-up pattern is the newest of the fashion movement theories. In this theory

the innovation is initiated from the street, so to speak, and adopted from lower income groups. The innovation eventually flows to upper-income groups; thus the movement is from the bottom up.

Examples of the trickle-up theory of fashion distribution include a very early proponent, Chanel, who believed fashion ideas originated from the streets and then were adopted by couture designers. Many of the ideas she pursued were motivated by her perception of the needs of women for functional and comfortable dress. Following World War II the young discovered Army/Navy surplus stores and began to wear pea jackets and khaki pants. Another category of clothing, the T-shirt, initially worn by laborers as a functional and practical undergarment, has since been adopted universally as a casual outer garment and a message board.

Thus how a fashionable look permeates a given society depends upon its origins, what it looks like, the extent of its influence, and the motivations of those adopting the look. The source of the look may originate in the upper levels of a society, or the street, but regardless of origin, fashion requires an innovative, new look.

### Product Innovation

A new look may be the result of innovations in the products of dress, the way they are put together, or the type of behavior elicited by the manner of dressing. A fashionable look involves the form of clothing on the human body and its potential for meaning (DeLong 1998). Meaning can derive from the product, but meaning can also develop from ways of wearing the product, or from the body itself (Entwistle 2000). Fashionable dress embodies the latest aesthetic and what is defined as desirable at a given moment.

Lehmann (2000) describes fashion as a random creation that dies as an innovation is born. He views fashion as contradictory, both defining the ancient and contemporary by randomly quoting from the past as well as representing the present. Robinson (1958) defines fashion as pursuing novelty for its own sake. Lipovetsky (1994) claims that determining factors in fashion are the quest for novelty and the excitement of aesthetic play, while Roche (1994) describes fashion as dynamic change.

Though fashion implies continual change, certain products have persisted over long periods of time, such as blue jeans, which were made a staple of dressing in the United States in the twentieth century. Though blue jeans are a recognizable form, there is the potential for great variety in the product details, including stone washing, dyeing, painting, tearing, and fraying. Blue jeans epitomize the growth of casual fashion and endure because they can change to resonate with the times.

The way products are combined can define a fashionable look. For example, the idea of buying "separates" to mix and match instead of buying complete ensembles has increased the separate purchases of jackets, trousers,

shirts, or blouses. The advent of the concept of separates coincided with the advent of the desired casual look. Mass production of sizes began to reflect a "one size fits all" model of fitting; more consumers could be fitted by choosing among the separate parts than would occur with the purchase of an ensemble with head-to-toe sizing requirements. Acceptance of separates and the growth of leisure was accompanied by a profound change, reflecting the restructuring of consumer societies and an increase in non-work lifestyles (Craik, p. 217).

### The Fashion Life Cycle

An innovation is perceived as having a life cycle, that is, it is born, matures, and dies. Rogers's (1983) classic writing spells out rate of change, including characteristics of the product, the market, or audience, the distribution cycle, and those characteristics of individuals and societies where innovation takes place.

*Diffusion of innovations.* Diffusion is the spread of an innovation within and across social systems. Rogers (1983) defines an innovation as a design or product perceived as new by an individual. New styles are offered each season and whether an innovation is accepted depends upon the presence of five characteristics:

1. Relative advantage is the degree an innovation is seen as better than previous alternatives, in areas such as function, cost, social prestige, or more satisfying aesthetics.
2. Compatibility is the degree to which an innovation is consistent with the existing norms and values of the potential adopters. An innovation is less likely to be adopted that requires a change in values.
3. Complexity concerns how difficult it is to learn about and understand the innovation. An innovation has a greater chance of acceptance if easily learned and experienced.
4. Trialability is the extent to which an innovation may be tested with a limited commitment, that is, easily and inexpensively tried without too much risk.
5. Observability is the ease with which an innovation may be communicated to others.

*The individual's role.* The fashion adoption process results from individuals making a decision to purchase and wear a new fashion. Rogers (1983) suggests that this process involves five basic stages: awareness, interest, evaluation, trial, and adoption. The individual becomes aware of the fashion, takes an interest in it, and evaluates it as having some relative advantage that could range from a new fabric technology or simply as being consistent with self concept or what one's friends are wearing. If the individual evaluates the fashion positively, the process proceeds to trial and adoption.

The study of the pattern of consumers' adoption of a fashion is often represented by a bell-shaped curve. The life cycle of a specific fashion represented graphically indicates duration, rate of adoption, and level of acceptance.

The graph depicts the rate and time involved in the diffusion process, with the horizontal axis indicating the time and the vertical axis indicating the number of adopters or users (Sproles and Burns 1994). Such graphically portrayed data can be used to calculate the level of acceptance for a fashion. For example, the curve for a fashion that is rapidly adopted but also rapidly declines will show early growth and quick recession. The curve resulting from plotting the data in this way leads to characteristic patterns of fashion adoption, applicable for fads or classics. The graph is also useful to identify type of consumer in terms of when each adopts a fashion within its life cycle. The consumer who adopts the fashion at the beginning of the curve is an innovator or opinion leader; at the peak, a mass-market consumer; after the peak, a laggard or isolate.

**Fashion leaders and followers.** Theories of fashion distribution all have in common the identification of leaders and followers. The fashion leader often transmits a particular look by first adopting it and then communicating it to others. Fashion followers include large numbers of consumers who accept and wear the merchandise that has been visually communicated to them.

A distinction exists between the role of the innovator and leader. The leader is not necessarily creator of the fashion or the first to wear it. The leader seeks distinction and dares to be different by wearing what the innovator presents as new. By adopting the look, the leader influences the flow or distribution of fashion. But the innovator within a group is also influential in serving as the visual communicator of the style. Historically the leader has been influential in some desirable way and possible leaders include athletes, movie stars, royalty, presidents, or fashion models.

### Characteristics and Influencing Factors

Basic tensions addressed by fashion in Western culture are status, gender, occasion, the body, and social regulation. Craik (1994) suggests potential fashion instabilities, such as youth versus age; masculinity versus femininity; androgyny versus singularity; inclusiveness versus exclusiveness; and work versus play (p. 204). Fashion systems generally establish means for self-formation through dress, decoration, and gesture that attempt to regulate such tensions, conflicts, and ambiguities.

**Social change and fashion.** Social change is defined as a succession of events that replace existing societal patterns with new ones over time. This process is pervasive and can modify roles of men and women, lifestyles, family structures, and functions. Fashion theorists believe that fashion is a reflection of social, economic, political, and cultural changes, but also that fashion expresses modernity and symbolizes the spirit of the times (Lehmann, 2000; Blumer 1969; Laver 1937). Fashion both reflects and expresses the specific time in history.

The tension of youth versus age has influenced dress in the twentieth century. The trend has been toward sep-

arate fashionable images for the younger and older consumer, especially with the burgeoning baby population that followed World War II. Fashions for the young have tended to take on a life of their own, especially with the parade of retro looks of the last decades of the twentieth century that increasingly borrow images of recent time periods. Roach-Higgins (1995) reasons that because fashionable dress requires an awareness of change in the forms of dress within one's lifetime, the older consumer who has experienced that look before may choose not to participate (Roach-Higgins, Eicher, and Johnson, p. 395).

How one dresses for work and play has changed over time. A persistent trend of the twentieth century has been toward coveting leisure time coupled with an increasing need to look leisurely. Wearing casual clothing and leisurewear increased in the 1950s because families moved to the suburbs and engaged in many outdoor activities and sports. Clothing for spectator sports has increased, as has clothing for participation in many sports, such as tennis, golf, jogging, cycling, skiing, and rock climbing. In the 1970s the number of women who adopted pantsuits encouraged the trend to more casual dressing. In the 1990s the workplace was infiltrated by casual dress on Fridays. The formal-informal nature of dress reflects how much importance is placed on dress for work and play, but also the ambiguity and tension involved.

**Appearance and identity.** Clothes are fundamental to the modern consumer's sense of identity. That criticism of one's clothing and appearance is taken more personally and intensely than criticism of one's car or house suggests a high correlation between appearance and personal identity (Craik, p. 206).

People may buy a new product to identify with a particular group or to express their own personality. Simmel (1904) explained this dual tendency of conformity and individuality, reasoning that the individual found pleasure in dressing for self-expression, but at the same time gained support from dressing similarly to others. Flügel (1930) interpreted paradox using the idea of superior and inferior, that is, an individual strives to be like others when they seem superior but unlike them when they seem inferior. In this way fashion can provide identity, both as an emblem of hierarchy and equalizer of appearance.

Whether or not fashion and the way products are combined upon the body can be considered as a visual language has been a source of discussion in recent years. Barthes (1983) insists that fashion be perceived as a system, a network of relationships. Davis (1992) concludes that it is better to consider fashion as a code and not as a language, but a code that includes expression of such fundamental aspects of an individual as age, sex, status, occupation, and interest in fashion.

**Culture, observer, and wearer.** Fashion favors the critical gaze of the knowing observer, or the one "in the know," and the wearer who arranges the body for his own



delight and enjoyment. Perceptions of the observer and wearer of fashion are sharpened based upon the many potential variations in lines, shapes, textures, and colors. For example, clothing of French inspiration and origin emphasized contour and cut of dress historically. Fashion changes occurred in the layout of the garment, which in turn focused attention on the silhouette and details, such as bias cutting and shaping (DeLong 1998). In contrast, societies where traditional dress has been worn, Korea, for example, fashion in traditional dress has derived more from the colors, motifs, and patterns adorning the surfaces, with the layout of the garments holding relatively constant. Thus subtle meaning derives not from the proportions of the *chogore* and *chima*, but from the variations found in the treatment of the surfaces (Geum and DeLong 1992).

**Dress, agency, and popular culture.** Popular culture can be defined loosely as those elements of entertainment that run alongside, within, and often counter to the elite structures of society. In the seventeenth century civilizing agents of aristocratic society included courtly entertainment, tournament, masque ball, and opera. But at the same time, popular culture became subject to increasing entrepreneurial control and commodification, with widening appeal to the urban merchant class (Beward 1995, p.97).

A new conception of popular culture was pertinent to the potential of dress as a communicator of social distinction and belonging. This movement preceded and contributed to the consumer and technological revolutions of the eighteenth century. Today popular culture is enhanced by the influence of mass media, and the medium has become the message, in many ways. According to Wilson (1985), fashion has become the connective tissue of the cultural organism and is essential to the world of mass communication, spectacle, and modernity.

**Pursuit of modernity.** Fashion is an accessible and flexible means of expressing modernity. The fashionable body has been associated with the city as a locus of social interaction and display (Beward, p. 35; Steele 1998). In the nineteenth century fashion was identified with a sense of contradiction of old and new. Modernity resulted in part from new technologies and a sense of the modern resulting from new ideas of design and consumption. Tensions from a growing commodification of fashionable trends emphasized the worldly and metropolitan. In the twentieth century modernity was identified through various but subtle means, from the way the dress contoured the body, to obvious product branding.

As a means of expressing modernity, Western fashions have been adopted by non-Western societies. In some societies where traditional styles of dress were prevalent, the men were quick to adopt Western business suits. Women have been slower to adopt Western dress in favor of traditional styles that express historical continuity. This creates an ambivalent message related to gender: Are women excluded from the modern world or

are they simply the purveyors of tradition? Traditional dress in South Korea is more often seen on older women on occasions of celebration (Geum and DeLong). Both Chinese men and women have been encouraged recently to adopt Western styles of dress (Wilson 1985).

**Gender and dress.** A tension exists when women have been assigned the dual role of being fashionable as well as the subordinate gender (Beward 1995). In the last two centuries fashion has been primarily assigned to women, and it follows that fashionable dress and the beautification of the self could be perceived as expressions of subordination. Male dress has been somewhat overlooked. Veblen (1899) in the nineteenth century described separate spheres of the male and female, with feminine sartorial dress as a symbol of enforced leisure and masculine dress a symbol of power. Display and appearance of the body were considered innately feminine pursuits and thus the model was constructed in which overt interest in clothing appearance implied a tendency toward unmanliness and effeminacy. This gave rise to ultra-conservative, non-expressive male dress codes that prioritized the uniformity of the city suit as the model for respectable middle classes for males in most of the nineteenth and twentieth centuries (Beward, p. 170). This model does not entirely explain the way men consumed fashion, for example, the aesthete of the 1880s and dandy of the 1890s.

Such expressions of difference in gender roles and fashionable appearances of men and women also occur in other historical periods. Within medieval culture, the display of masculinity and femininity varied according to class, age, wealth, and nationality. Clothing, fashionably cut, moved toward overt display of the body and its sexual characteristics (Beward, p. 32). Interpretations of a male and female ideal permeated visual and literary interpretations of the human body. The male ideal focused upon proportion, strength, nobility, and grace; the female ideal included diminutive size, delicacy, and heightened color.

In medieval society, concepts of femininity included monopoly on production and maintenance of textiles, clothing, and accessories and the display of patriarchal wealth and status. When the monopoly of women was broken, production of clothing moved from the home to the public sphere. Male-dominated systems of apprenticeships emerged for weavers, cloth cutters, and tailors; the mass production and marketing system was born.

### Market Forces and Momentum

The fashion industry has led the way, or followed, depending upon the nature of the fashion and its origins (Wilson 1985). Fashions serve as a reflection of their time and place and can be determined by society, culture, history, economy, lifestyle, and the marketing system. The market for fashion ranges from the world of couture to mass-produced clothing called ready-to-wear.

The couture fashion system and the couturier, who regularly presents a collection of clothing, originated in Paris, France. The couturier caters to the handmade, made-to-measure, exquisite product. In some ways the couturier functions as an artist, but when the product fails that designer ceases to exist. In this way the couturier walks a fine line between artist and industrialist (Baudot, p.11). The dominance of Paris as an international center depends as much on its sophistication as a fashion center as on the superiority of its clothing (Steele 1998).

Other countries beside France have taken on fashion leadership—notably, Italy, the United Kingdom, and the United States—and each country has placed its unique stamp on fashion (Agins 1999). For example, Milan, the hub of the Italian fashion industry is close to the country's leading textile mills in the Lake Como region. The Italians not only produce beautiful fabrics, they also design beautiful clothes as exemplified by such notable talents as Giorgio Armani and Krizia.

Though some may consider fashion frivolous, it is also considered a serious, lucrative business in capitalist society. The United States has been a leader in the technologies required for mass production and mass marketing of apparel, making fashion a democratic possibility, available to all.

***Mass production and democratization of clothing.*** To provide clothing at moderate cost for all citizens took two primary developments, mass production and mass distribution (Kidwell and Christman 1974). Mass production required developing the technology for middle-quality clothing that could be made available for the majority. Mass distribution required the retailing of ready-made clothing and innovations in salesmanship and advertising. Department stores sprang up in every city following the Civil War and by the end of the century, mail-order houses were developed sufficiently to reach all citizens in the United States.

The clothing revolution that occurred in the twentieth century in the United States was a double revolution. The first was the making of clothing, from the homemade and custom-made to the ready-made or factory-made; the second was the wearing of clothing, from clothing of class display where clothing was worn as a sign of social class and occupation, to the clothing of democracy where all could dress alike. According to Kidwell and Christman (1974), in the eighteenth century anyone walking in Philadelphia or Boston could easily have distinguished towns people from country folk by the striking differences in their clothing. Clothing was distinctive because of differences in textiles and clothing construction. America was dependent upon England's textile industry so the rich purchased fine-quality silks, woolens, and cottons while others had limited access to fabrics that were coarse and middle to low grade. The tailor and dressmaker made clothing for the rich and the amateur made clothing for the average person.

In the nineteenth century, the industrial revolution brought the machine, the factory, and new sources of power. A series of great inventions mechanized the making of yarn and cloth. By 1850 machines included the invention and distribution of a practical sewing machine that was quickly adopted for men's shirts and collars and women's cloaks, crinolines, and hoopskirts. By the end of the nineteenth century, machine cutting was standard; pressing became more efficient. Men began to look and dress alike, and the sameness of their dress made multiple production by machine entirely possible.

Ready-made clothing for women lagged behind what was available for men. In 1860 ready-mades for women included only cloaks and mantillas, and dressmakers continued to supply women's fashions. Women of limited income made their own clothing, thus saving their clothing dollars for male family members. The department store and mail order were established means of distribution in the latter half of the nineteenth century.

In the early twentieth century, the mass-manufacturing process was organized and capable of producing clothing for both men and women. Thus was born an industry of industries, each with a system of organization to create ready-made clothing for everyone (Kidwell and Christman 1974). Though fashion always was an identifier of person, mass production equalized every person's opportunity to identify.

***Marketing and distribution systems.*** Entwistle (2000) describes fashion as the product of a chain of activities that includes industrial, economic, cultural, and aesthetic. Changes in production and marketing strategies allowed for the expansion in consumer activity during the second half of the eighteenth century that led to increased consumption and the speeding up of the fashion cycle. This led to an increase in fashions that could be selected to reflect specific and individual circumstances.

In the twentieth century consumer choice was affected by means of mass distribution including chain stores, mail order, and Internet shopping. Chain stores have made fashion accessible within a relatively short drive for most consumers. Mail order has enabled a consumer in a remote area to follow fashion trends, select an appropriate garment, and place an order for ready-made clothing. Internet shopping relies on a person's access to a computer. Chain stores, mail order, and Internet shopping have extended the reach of fashion and created new consumer groups.

### **A Historical Perspective**

Fashion is viewed broadly as a chronology of changing forms and a critique of wider cultural influences and their historical interpretation (Carter 2003; Johnson, Tortore, and Eicher 2003). The history of fashion reveals the importance of changes in appearance, but also the way fashion is conceived, who participates, and for what and how many occasions. The middle years of the fourteenth cen-

tury have been identified as the first period of significant fashion change, generally related to the rise of mercantile capitalism in European cities (Lipovetsky 1994; Roche 1994; Breward 1995; Tortore and Eubank 1998). At that time, fashion became a practice of prestigious imitation among social groups and changes in tastes occurred often and were extensive enough for people to gain an appetite for new fashions in dress (Lipovetsky 1994; Roche 1994; Breward 1995). With class distinctions on the wane and an accelerated rate of stylistic change, the specific character of dress was associated with gender and the circumstance of different lifestyles. In the history of fashion, modern cultural meanings and values, especially those that elevate newness and the expression of human individuality to positions of dignity have allowed the fashion system to come into being and establish itself (Lipovetsky, p. 5).

The rise of fashion is associated with “the civilizing process” in Europe. The medieval woman engaged in what became the feminine pursuits of weaving, textile work, and fashion. Fashion in medieval society had a direct impact on the emerging of the individual, on self-knowledge, and understanding one’s place in the world (Breward, p. 34). The body provided a principal means of expression through clothing; for example, to throw down one’s glove was an act of defiance that committed a person to certain actions. The deliberate manipulation of the social meanings attached to clothing helped initiate a heightened sense of the significance of fashion.

Though fashion was first created for the privileged few, in the late nineteenth and twentieth century mass production made fashion accessible to the majority. In the nineteenth century the distinguishing feature of fashion was its imposition of an overall standard that nevertheless left room for the display of personal taste. Fashion change accelerated with major apparel changes occurring in twenty-year intervals.

The twentieth century is characterized as the age of mass production, mass consumption, and mass media. Mass fashion became a form of popular aesthetics and a means of self-enhancement and self-expression. Advances in technology and materials used for clothing production provided more comfortable, cheaper, and more attractive items to a larger proportion of the population. In the early twentieth century, mass consumption of fashionable dress increased within the sphere of fashion promotion and advertising, leading to unlimited diversification. The fashion industry became more complex and fashion intervals shortened to ten years (Tortore and Eubank 1998).

Mass media has allowed for wide dissemination of fashion information and opportunities for the stimulation of a more homogeneous public imagination. The fashion magazine and the Hollywood film brought fashionable models to a hugely expanded audience from the 1920s onward. Examples of fashionable dress were often made available through the expansion of chain stores and mail-

order companies. At the same time, a reorganization of business practices, of marketing and advertising, prioritized certain strands of society as fashion leaders. A cult of the designer, revolving around ideals of couture and high fashion or strong subcultural identities, ensured the survival of hierarchies based on notions of quality, style, and individuality (Breward, p. 183).

Steele (2000) surmised that in 1947 when Christian Dior launched his “New Look,” it was still possible for a fashion designer to transform the way a woman dressed. The postwar transformation was remarkable, from the war years of boxy shoulders, rectangular torso, and short skirts to the postwar look of narrow shoulders, nipped-in waist, padded hips, and long, full, flowing skirts. You could like it or hate it, but the look was the fashion, regardless (Steele 2000, p. 7).

Today major fashion changes occur frequently, but the choices and selections have increased so that mainstream fashion is one choice among many, including recycled clothing, vintage clothing, and wearable art. Also the easily recognizable rules of fashion, such as rigid proportions, hem lengths, and silhouettes now relate more to the particular look of one group than to a fashionable look for all. Agins (1999) has declared the end of fashion, but only as it has been known historically.

See also **Fashion, Historical Studies of; Trickle-Down.**

#### BIBLIOGRAPHY

- Agins, T. *The End of Fashion*. New York: William Morrow, 1999.
- Barthes, R. *The Fashion System*. New York: Hill and Wang; Farrar, Straus, and Giroux, 1983.
- Baudot, F. *Fashion, The Twentieth Century*. New York: Universe, 1999.
- Benedict, R. “Dress.” *Encyclopedia of the Social Sciences*. New York: Macmillan, 1931.
- Blumer, H. “Fashion: From Class Differentiation to Collective Selection.” *The Sociological Quarterly* 10, no. 3 (1969): 275–291.
- Brannon, E. *Fashion Forecasting*. New York: Fairchild Publications, 2000.
- Breward, C. *The Culture of Fashion*. Manchester, U.K.: Manchester University Press, 1995.
- Carter, M. *Fashion Classics: From Carlyle to Barthes*. Oxford: Berg, 2003.
- Craik, J. *The Face of Fashion*. New York: Routledge, 1994.
- Davis, F. *Fashion, Culture, and Identity*. Chicago: University of Chicago Press, 1992.
- DeLong, M. *The Way We Look, Dress and Aesthetics*. 2nd ed. New York: Fairchild Publications, 1998.
- Entwistle, J. *The Fashioned Body, Fashion, Dress and Modern Social Theory*. Cambridge, Mass.: Polity Press, 2000.
- Flügel, J. *The Psychology of Clothes*. London: Hogarth Press, 1930.
- Geum, K., and M. DeLong. “Korean Traditional Dress as an Expression of Heritage.” *Dress* 19 (1992): 57–68.
- Johnson, K., S. Tortore, and J. Eicher. *Fashion Foundations: Early Writings on Fashion and Dress*. Oxford: Berg, 2003.



- Kidwell, C., and M. Christman. *Suiting Everyone: The Democratization of Clothing in America*. Washington, D.C.: Smithsonian Institution Press, 1974.
- King, C. "Fashion Adoption: A Rebuttal to the 'Trickle Down' Theory." In *Toward Scientific Marketing*. Edited by S. Greyser. Chicago: American Marketing Association, 1963.
- Laver, J. *The Concise History of Costume and Fashion*. New York: Harry N. Abrams, 1969.
- Lehmann, U. *Tigersprung: Fashion in Modernity*. Cambridge, Mass.: MIT Press, 2000.
- Lipovetsky, G. *The Empire of Fashion*. Princeton, N.J.: Princeton University Press, 1994.
- McCracken, G. "Meaning Manufacture and Movement in the World of Goods." In *Culture and Consumption*. Bloomington: Indiana University Press, 1988.
- Nystrom, P. *Economics of Fashion*. New York: Ronald Press, 1928.
- Polhemus, T. *Streetstyle: From Sidewalk to Catwalk*. London: Thames and Hudson, Inc., 1994.
- Roach-Higgins, M. E. "Awareness: Requisite to Fashion." In *Dress and Identity*. Edited by M. E. Roach-Higgins, J. Eicher, and K. Johnson. New York: Fairchild Publications, 1995.
- Robinson, D. "The Rules of Fashion Cycles." *Harvard Business Review* (November–December 1958).
- . "Style Changes: Cyclical, Inexorable, and Foreseeable." *Harvard Business Review* 53 (November–December 1975): 121–131.
- Roche, D. *The Culture of Clothing*. Translated by J. Birrell. Cambridge, U.K.: Cambridge University Press, 1994.
- Rogers, E. *Diffusion of Innovations*. 4th ed. New York: Free Press, 1995.
- Simmel, G. "Fashion." *International Quarterly* 10 (1904): 130–155.
- Sproles, G., and L. Burns. *Changing Appearances*. New York: Fairchild Publications, 1994.
- Steele, V. *Paris Fashion: A Cultural History*. Rev. ed. Oxford: Berg, 1998.
- . "Fashion: Yesterday, Today and Tomorrow." In *The Fashion Business*. Edited by N. White and I. Griffiths. Oxford: Berg, 2000.
- Tortore, P., and K. Eubank. *Survey of Historic Costume*. 3rd ed. New York: Fairchild Publications, 1998.
- Veblen, T. *The Theory of the Leisure Class*. New York: Macmillan, 1899.
- Wilson, E. *Adorned in Dreams: Fashion and Modernity*. London: Virago Press, 1985.

Marilyn Revell DeLong

**FASHION ADVERTISING** Fashion advertisements have their own stylistic modes and spheres of production and consumption, involving the interrelationship of word and image among other things. Yet, technological and social changes in clothing and retailing, and the impact of class, gender, and race politics, also have to be taken into account. Early forms of fashion promotion that origi-

inated in the eighteenth century, for example, overlapped with the rise of urban culture and shopping and embraced diverse forms of promotion, some of which we might not strictly recognize today as advertising. In the first instance, the majority of retailers regarded the creation of an enticing shop façade and interior as sufficient means for attracting and establishing a suitable clientele. This would subsequently be complemented by the circulation of handbills and trade cards, and to a lesser extent by press advertising, all of which were used to reinforce the reputation of the shop in question rather than to publicize the sale of particular wares. In the *London Evening Post* for 24 April 1741, for example, the haberdasher John Stanton placed an advertisement, not to tell the public about the goods he sold but to inform them of a change of trading address. Otherwise, newspaper advertisements were occasionally used by large-scale retailers and manufacturers to promote both new and secondhand goods at fixed prices, and from the 1760s tailors also began to advertise different items of male and female clothing. The emphasis of such publicity was the printed word and the general format was the list, enumerating the items on offer and how much they cost. By contrast, more alluring pictorial representations of the latest fashions were available as engraved or etched plates, displayed for sale in print sellers' windows and also incorporated into such volumes as Heidelhoff's *Gallery of Fashion* (1794–1802) and intermittently in magazines like the *Lady's Magazine*.

During the late eighteenth and early nineteenth centuries, the nexus between what Roland Barthes refers to as image-clothing and written clothing in *The Fashion System* became more evident in French and British publications, such as the *Cabinet des Modes*, *La Belle Assemblée*, and Ackermann's *Repository of Arts*, where illustrations were accompanied by captions and editorials concerning changes in the styles of fashion. These titles were the forerunners of such popular illustrated weeklies as the *Illustrated London News* (ILN), *Graphic*, *Lady's Pictorial*, and *Ladies' Home Journal*, which had sprung up by the mid-nineteenth century on both sides of the Atlantic to cater to middle-class readers and in which the first distinctly recognizable alpha-pictorial advertisements for clothing retailers appeared. Many of these promotions, however, were similar in approach to the "reason why" format of their antecedents since they consisted of straightforward wood-engraved illustrations of women—and men—wearing the garments alongside text that relates the cost of the clothing represented and where it could be purchased. Occasionally more suggestive or atmospheric forms of advertising, in which the product appeared in a situational context, cropped up. Thus press promotions during the 1880s and 1890s in *Lady's Pictorial* and *Graphic* for "My Queen" Vel-Vel, a velvet for dressmaking, resorted to the trope of Queen Victoria as consumer. In them, she is embodied in a domestic setting as a saleswoman unfurls the fabric before her. Yet, Victoria's detached gaze and demeanor transcend the material situation, and it is rather

her majestic aura that symbolically bestows favor on the fabric and invests it with value.

By the turn of the century, the color lithographic poster, pioneered by Jules Chéret in France, had also become a popular form of advertising internationally, although there are few extant examples relating directly or exclusively to fashion promotion. In 1900, for instance, H. G. Gray produced a poster to publicize the latest fashions on sale at the Parisian department store Prix Unique. Publicity for some manufacturers also tended to a form of double symbolism; hence an 1885 poster for the American company New Home Sewing Machine, representing a mother painting and a daughter playing with a cat in their new clothes, not only represented the products that such domestic technologies enabled but the leisure time that they also afforded middle-class women.

The seeds for a modern, atmospheric form of fashion advertising, therefore, were sown by the late nineteenth century. Not until the twentieth century, and especially the interwar period, did an evident quantitative and qualitative shift take place in the promotion of fashion and clothing for women and men. This was due in no small measure to the expansion of the ready-to-wear and bespoke markets, as well as the professionalization of the advertising industry itself, which had begun to get involved more systematically with market segmentation and to probe what made different types of consumers tick in terms of sex, age, and class. At the same time, the impact of modernist aesthetics, the role of the copywriter, and the deployment of avant-garde designers and photographers also greatly transformed fashion advertising.

Prussian-born Hans Schleger (alias Zéró) was probably the most renowned of this new breed of commercial artists, and he worked both in Europe and America. Between 1925 and 1929, he was hired by outfitters Weber and Heilbronner of New York to transform their advertising campaigns. To this end he devised press advertisements that dynamically conveyed a sense of rhythm and proportion, such that the layout of asymmetric or expressive typeforms into wave or wedge formations was complemented by the shape and directional thrust of the illustrations or photographs. In 1929, he struck up an association with the pioneering British advertising agency W. S. Crawford (founded 1914), which held accounts for Wolsey hosiery and Jaeger amongst others. Working in collaboration with the copywriter G. H. Saxon Mills, he created imaginative promotions for Charnaux corsets that appeared in *Vogue* during the 1930s and that used sporting metaphors to emphasize the idea of health and freedom in the design and wearing of undergarments.

America took the lead in pioneering the evolution of photographic advertising during the early 1920s, with Clarence White, who had founded a school of photography in New York in his own name in 1914 and the Art

Center in 1921, becoming one of the first apologists for its application. The modern style he advocated was based on sharp focus, simple geometry, and oblique perspectives, and manifested itself in the photography of the school's most well-known graduates, Edward Steichen and Paul Outerbridge. The former promulgated the idea of straight photography in advertising campaigns for Real-silk hosiery in *Ladies' Home Journal* between 1927 and 1937, and the former in his campaign for the Ide Shirt Collar, which was photographed in stark isolation against a checkerboard and published in *Vanity Fair* in November 1922. In Europe, similar ideas had taken root during the 1920s with the advent of the *Neue Sachlichkeit* (New Objectivity). Thus, László Moholy-Nagy, in "How Photography Revolutionizes Vision" (1933), espoused a battery of different techniques, including photomontage and the photogram, and a range of different stylistic approaches to the object, such as the introduction of the greatest contrasts, the use of texture and structure, and the use of different or unfamiliar perspectives that offered "new experiences of space." All of these formal concerns are evident in an advertisement in *Punch* in 1933 for Austin Reed shirts featuring a color photograph of bales of material, which invites us to contemplate everyday objects from a fresh vantage point.

The photographic forms of fashion advertising that had begun to supplant the use of hand-drawn illustrations during the 1930s continued unabated after World War II. By the mid-1950s the market for teenage and youth fashions had also influenced the sexual iconography of many advertisements. A common motif in press promotions during the 1960s for designers as diverse as Mary Quant and Dior, and garments from miniskirts to coats and trousers to tights, was the woman-child, represented clowning in playful poses or pouting provocatively. Between 1961 and 1963, photographs by David Olins of "the girl" wearing a man's shirt were also deployed in poster and press ads to promote the Tootal brand. At the same time, the male consumer was drawn into this ornamental realm of desire and in promotions for Newman Clothing during the 1960s was depicted as the object of the adoring female admirers who surrounded him. But it would be erroneous to argue that men had not been objectified in this way before; in poster advertisements for Pope and Bradley in 1911–1912 and in many of those by Tom Purvis for Austin Reed during the 1930s, as well as press advertisements for multiple tailors like the Fifty Shilling Tailors, the fashionable peacock was connoted as someone who could turn women's heads.

Since the 1960s it is probably more casual forms of dress, and jeans in particular, that have made an appeal on television and in the press to both men and women in terms of sexual desire. As competition between brands and designer labels heated up in the late 1970s and early 1980s, advertisers began to fetishize the contour-hugging nature of denim. Thus press ads for Calvin Klein, fea-

turing Brooke Shields, and for Jordache traded on close-ups of pert buttocks clad in jeans. In this vein, the retro British television campaign for Levi 501's (masterminded by Bartle, Bogle and Hegarty and screened in 1985–1986), which featured Nick Kamen stripping down to his boxer shorts in a launderette, initiated a more subtle and ambiguous form of sexual objectification.

Interestingly, although Levi's are sold across the world, publicity for the brand has not been orchestrated on a multinational basis. In comparison with the retro-styled British television and press campaigns of the 1980s, for instance, in America the "501 Blues" television advertisements traded on the idea of nonconformity by associating the product with contemporary street-smart individuals and blues music, while press advertisements tended to foreground the idea of jeans as leisure wear on a more conventional or "reason-why" level with images of men playing pool or dressing down for the weekend. At the same time, in Japan, the retro association of Levi's and the 1950s was symbolized by images of James Dean.

One company that has promoted itself on a multinational basis is Benetton, and in doing so, it has transformed the way that clothing can be publicized. Under the banner "United Colors of Benetton," the company's artistic director Oliviero Toscani mobilized fashion advertising to promote historical and ideological consciousness of issues as wide as race and national identities, religion, and HIV/AIDS. Between 1985 and 1991, he juxtaposed young people of disparate ethnic origins in the hope of encouraging racial tolerance, and since that time he has manipulated existing news photographs, such as a man shot dead by the Mafia, or created politicized images, such as his photograph of blood-stained garments worn by a dead militant in the Serbo-Croat conflict, to connote a similar message of national and international harmony. Such events have little or nothing to do with Benetton per se, whose exploitative production methods have themselves been subject to moral scrutiny, and it is debatable whether they draw more attention to the company rather than raising awareness of the issues with which they purport to be concerned. Nonetheless Benetton advertising remains at the cutting edge artistically and ideologically, and not least in the way that it has encouraged other fashion advertisers to deal with the ambiguities of sexual and racial identities.

The leitmotiv of many promotions for clothing at the turn of the millennium, therefore, has been the queering of femininities and masculinities, such that the normative dynamics of spectatorial pleasure and the gaze are leitmotiv problematized (much as they had been earlier in the twentieth century in the homoerotic advertisements designed by J. C. Leyendecker for the Arrow Shirt Collar). Key examples of this kind of promotion since the 1990s include advertisements for Versace, Calvin Klein, Dolce & Gabbana, Diesel, Ben Sherman, Northwave Shoes, and Miss Sixty, all of which exploit the tension between straight and gay identities for men and women,

and white and nonwhite spectators alike. At the same time, some designers like Vivienne Westwood and Yves Saint Laurent, and companies like Diesel have made post-modern intertextual references between well-known works of art or the cult of media celebrity and their own products not only to deconstruct the meaning of personal identities but also to undermine the distinction between the representation and reality of fashion itself.

See also **Art and Fashion; Economics and Clothing; Fashion Magazines; Fashion and Homosexuality; Retailing.**

#### BIBLIOGRAPHY

- Goffman, Erwin. *Gender Advertisements*. London: Macmillan, 1979.
- Loeb, Lori-Anne. *Consuming Angels: Advertising and Victorian Women*. New York: Oxford University Press, 1994.
- Moholy-Nagy, László. "How Photography Revolutionizes Vision." *The Listener* (November 1933): 688–690.
- Mort, Frank. *Cultures of Consumption: Masculinities and Social Space in Late Twentieth-Century Britain*. London: Routledge, 1996.

*Paul Jobling*

**FASHION AND HOMOSEXUALITY** Throughout the twentieth century, clothing has been used by lesbians and gay men as a means of expressing self-identity and of signaling to one another.

#### Male Cross-Dressing

Even before the twentieth century, transvestism and cross-dressing among men were associated with the act of sodomy. By the eighteenth century, many cities in Europe had developed small but secret homosexual subcultures. London's homosexual subculture was based around inns and public houses where "mollies" congregated. Many of the mollies wore women's clothing as both a form of self-identification and as a means of attracting sexual partners. They wore "gowns, petticoats, headcloths, fine laced shoes, furbelowed scarves, and masks; [and] some had riding hoods; some were dressed like milk maids, others like shepherdesses with green hats, waistcoats, and petticoats; and others had their faces patched and painted" (Trumbach, p. 138).

Male homosexuals continued to cross-dress in both public and private spaces throughout the nineteenth century. In the 1920s, the Harlem drag balls offered a safe space for gay men (and lesbians) to cross-dress. Similarly the Arts Balls of the 1950s in London offered an opportunity denied in everyday life. Cross-dressing performers, commonly known as drag queens, used women's clothes to parody straight society and create a gay humor. One of the greatest American drag performers was Charles Pierce, who began his career in the 1950s, and was best known for his impersonations of film stars such as Bette Davis and Joan Crawford. The tradi-





*Una, Lady Troubridge, 1924.* The period between the two world wars saw a rise in the visibility of lesbians. This oil-on-canvas portrait by artist Romaine Brooks typifies the masculinized lesbian dress of the period. Note the wing collar, monocle, and men's jacket. © SMITHSONIAN AMERICAN ART MUSEUM, WASHINGTON, DC/ART RESOURCE, NY. REPRODUCED BY PERMISSION.

tion has been carried on by gay drag performers such as American performers Divine and RuPaul and British television star Lily Savage.

### **Effeminacy**

Overt gay men, who did not want to go so far as to cross-dress, sometimes adopted the most obvious signifiers of female mannerisms and dress: plucked eyebrows, rouge, eye makeup, peroxide blond hair, high-heeled shoes, women's blouses. In America it was illegal for men (and women) to cross dress unless attending a masquerade. At least three items of clothing had to be appropriate to the gender. Adopting such an appearance was dangerous, for it was risky to be overtly homosexual. In his autobiography, *The Naked Civil Servant* (1968), Quentin Crisp recalls being stopped a number of times by police because of his effeminate appearance. However, the risks were worthwhile for many. Dressing as a "flaming queen" was a means of entering into the subculture of gay society. Also, by adopting female characteristics and by adhering to strict gendered rules of sexual behavior, queens could attract allegedly "normal," straight sexual partners. The adoption of effeminate dress codes began to wane with the rise of gay liberation, but has continued to play a role in gay life.

### **Masculinity and Lesbian Dress**

In the late nineteenth and early twentieth centuries, the adoption of male dress was a means for many women, including many lesbians, to protest the status of women and the roles assigned them by patriarchal societies. Cross-dressing had been and continued to be utilized by women to allow them to "pass" as men and be accepted. Some, like writer George Sand and painter Rosa Bonheur utilized the methods in order to have their professional work be taken seriously. The period between the two World Wars saw a rise in lesbian visibility. The typical masculinized lesbian dress of the period is typified by the wing collar, monocle, and man's jacket worn by Lady Una Troubridge (lover of Radclyffe Hall, author of *The Well of Loneliness*) in her portrait by Romain Brooks. In America, lesbian performers such as Ma Rainey and Gladys Bentley wore men's top hat and tails to express their identity, while bisexual film stars Greta Garbo and Marlene Dietrich wore masculine clothes both on- and offscreen.

Until the 1970s, the public image of lesbians was very much centered on masculinity. As a means of asserting difference and signaling to other lesbians, many women-loving women adopted certain "masculine" markers, such as a collar and tie or trousers. In America, it was illegal for women to dress completely in men's clothes, and they were required to wear "three pieces of women's clothing" (Nestle, p. 100). Public reaction was not sympathetic to "butch" lesbians. American lesbian writer and activist Joan Nestle "walked the streets looking so butch that straight teenagers called [her a] bulldyke" (Nestle, p. 100).

Not all lesbian women felt drawn to the adoption of male clothing, preferring instead more conventional female attire: makeup, high-heeled shoes, and skirts. Many accounts of lesbian bar life note the prevalence of "butch" and "femme" identities and behavior, where butch lesbians were expected to form relationships only with femme lesbians, and lesbians were expected to identify with one role or the other.

### **Subtle Signifiers**

The illegality of homosexuality and the moral disapproval that it attracted forced gay men and lesbians to live virtually invisible lives in the first part of the twentieth century. Up until the gay liberation movement of the late 1960s, the most important criterion of dressing in public, for the mass of gay men and lesbians, was to be able to "pass" as heterosexual. Despite this need, many were aware of the dress codes and items that could be used to signal sexual orientation. These symbols of identity often took the form of a specific type or color of accessory and, like other secret symbols, developed and changed over time. The primary signifier at the time of the Oscar Wilde trials in the 1890s was the green carnation. Indeed, the color green had been associated with the effeminate and sometimes sodomitical macaronis of the 1770s and continued to have gay associations in clothing through the first part of the twentieth century. George Chauncey notes that in 1930s New York City, green suits were the badge of open "pansies." Other signifiers for gay men included a red necktie (worn in New York City before World War II) and suede shoes (one of the most international and enduring gay signifiers). Lesbian signifiers included accessories such as ties and cufflinks, short haircuts (particularly the "Eton crop" of the 1920s), and the color violet.

### **Menswear Revolution**

During the "menswear revolution" of the 1960s, the association of fashion and homosexuality began to diminish. With the rise in subcultural fashions and the dissemination of Carnaby Street fashions around the world, it was suddenly acceptable for young men to be interested in fashion, and to spend time and money on clothes and appearance. Carnaby Street fashions were initially sold to a gay "theatrical and artistic" clientele by a former physique photographer by the name of Vince from a shop near Carnaby Street. John Stephen, who was later to be known as the "King of Carnaby Street," had worked at Vince's shop and produced the clothes faster, cheaper, and for a younger market. In America, too, a close-fitting "European style" worn primarily by gay men, was sold from "boutiques" in Greenwich Village, New York, and West Hollywood in Los Angeles.

### **Gay Men and Masculinity**

By the late 1960s, lesbians and gay men throughout the Western world had begun to question their position as

second-class citizens and their stereotype as effeminate “queens” or “butch dykes.” Along with the demands for equality and recognition, lesbians and gay men began to address their appearance. There had always been gay men who dressed in a conventionally masculine style, but in the early 1970s, gay men in New York and San Francisco looked to the epitomes of American masculinity—the cowboy, the lumberjack, the construction worker—for inspiration for a new dress style. The clones, as they were known, adopted the most masculine dress signifiers they could find—work boots, tight Levi’s, plaid shirts, short haircuts, and moustaches. Their clothes were chosen to reveal and celebrate the contours of the male body.

Some clones also developed their sexual tastes by experimenting with sadomasochism. Consequently, they sometimes adopted a “leatherman” appearance and lifestyle, which involved a strict codification of dress and a new system of signifiers, most notably colored handkerchiefs in a back pocket, specifying particular sexual interests. The hypermasculine image has continued to be important even after the supposed death of the clone in the late 1980s, when the image became associated with an older generation of pre-AIDS gay men. Gay men have interpreted and demonstrated their masculine looks through the celebration of muscular “gym” bodies and clothing that shows off those bodies, as well as the emergence of other masculine subcultural styles such as the shaven-headed, boots and braces wearing, but not necessarily racist skinhead.

### Post-Liberation Lesbian Style

The advent of both the women’s and gay-rights movements led to a questioning of the stereotyped dress choices previously available to lesbians. Trousers had become increasingly acceptable for women from the 1950s, and during the 1960s it became more difficult to identify lesbians on the grounds of trouser-wearing. “Androgyny” became a key word in fashion, and this manifested itself in various ways. Initially, the move was toward a feminine look for men, but the radical lesbian and gay community rejected this in favor of a more masculine look for both men and women.

The rise of radical feminism saw a rejection of fashion-forced femininity. Flat shoes, baggy trousers, unshaved legs, and faces bare of makeup made a strong statement about not dressing for men. Radical feminist politics during the 1970s took this to an extreme as a new stereotype was born—that of the dungaree-wearing, crew-cut lesbian feminist.

The 1980s and 1990s saw a new diversification in lesbian dress. The breakdown of the old butch and femme divides, the changes instigated in women’s dress by feminism and punk, and the increasing visibility in public life of lesbians opened up the debate about what lesbians could and should wear. One of the most significant developments was the appearance of the lipstick lesbian

(also known as glamour or designer dyke). Dress styles signaled a move away from the traditional butch or radical-feminist styles and allowed out gay women to develop a fashionable urban look that combined signifiers of lesbianism or masculinity with fashionable women’s dress. However, critics accused lipstick lesbians of hiding behind a mask of heterosexuality.

### The Fashion Industry

The large proportion of gay men who have worked in creative fields of fashion and the theater and service industries, such as catering, has been well documented by historians such as Ross Higgins, whose study highlighted the involvement of gay men at all levels of the fashion industry in Montreal.

Throughout the twentieth century, many of the top couture fashion designs were gay, even though social pressure called for them to keep their sexuality quiet if not secret. Indeed, many of the greatest names in twentieth-century fashion were gay or bisexual, including such figures as Christian Dior, Cristobal Balenciaga, Yves Saint Laurent, Norman Hartnell, Halston, Rudi Gernreich (who was one of the founding members of the first American homophile organization, the Mattachine society), Calvin Klein, and Gianni Versace.

As designers took over from traditional tailors and gentleman’s outfitters in men’s fashion, a new gay influence became evident. Because gay men were often more willing to experiment with new ideas, styles, and fabrics in clothing, designers such as Jean-Paul Gaultier began to look at what was happening at street level and in gay clubs for ideas for their men’s collections. Moreover, gay men bought clothes that were influenced by and styled toward a gay aesthetic, so their taste influenced fashion in both obvious and subtle ways.

The advent of the “new man” (as a media icon) in the 1980s was a result of men’s reaction to major social changes brought about by a second wave of feminism. As a consequence, it became acceptable for straight men to be interested in their appearance, clothes, and grooming products. New magazines aimed at a wider, heterosexual male consumer were published, but even here a gay influence could be perceived. It was not just that gay designers were creating the looks, but gay stylists, hairdressers, and photographers all exerted a fashion influence. For example, stylist Ray Petri (featured in *The Face*, *i-D*, and *Arena* magazines) drew on looks that he saw in gay clubs to create a whole new style known as Buffalo. Buffalo style dressed black and white, gay and straight models in an unlikely mix of elements such as cycling shorts, flight jackets, skirts, hats, and boots.

The early 1990s saw the advent of “lesbian chic” in the fashion world. This manifested itself most visibly in a series of photographs in *Vanity Fair* in 1993, including a cover that featured lesbian singer k. d. lang cavorting with supermodel Cindy Crawford.



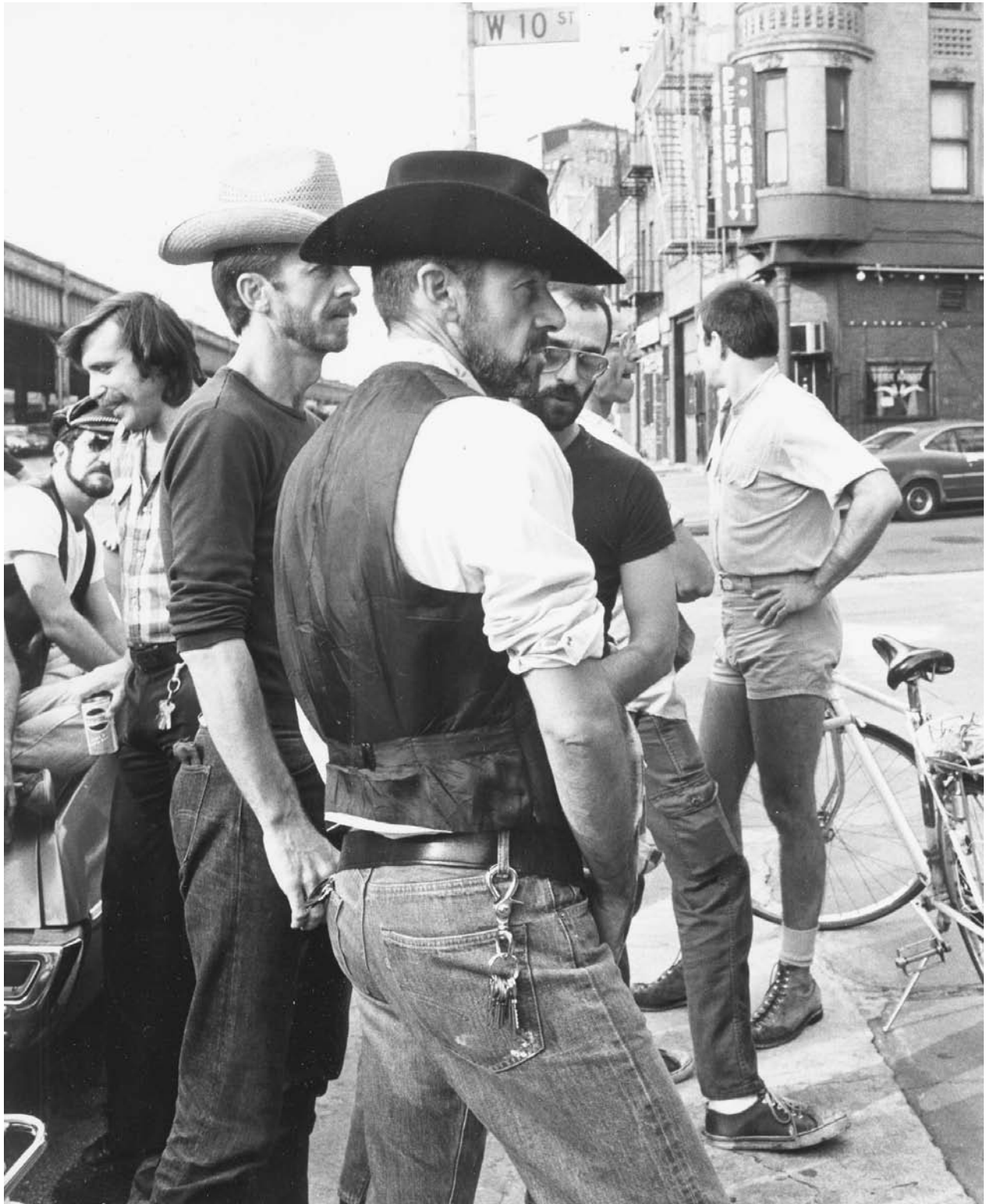

**Homosexual men in cowboy clothing.** In the 1970s, gay men began to look to traditional icons of masculinity for fashion inspiration, donning rugged clothing that showed off the physique. PHOTO BY LEONARD FINK, LESBIAN, GAY, BISEXUAL & TRANSGENDER COMMUNITY CENTER. REPRODUCED BY PERMISSION.

Today it is perfectly acceptable for straight men to be interested in fashion and to be obvious consumers of clothes, grooming products, and fashion or “lifestyle” magazines. Popular figures, such as soccer player David Beckham, are avid consumers of clothes and even acknowledge their debt to gay men’s influence on fashion. In an age where homosexuality is tolerated and to a great extent accepted in major urban centers, it has become increasingly difficult to distinguish gay and straight men, and lesbians and straight women, on the basis of their dress. Acknowledging this, Elizabeth Wilson poses the following question: “Throughout the queer century we have disguised and revealed our deviant desires in dress, masquerade, disguise. Now that everyone’s caught on in a postmodern world, what do we have to do to invent new [gay and] dyke style?” (Wilson, 177)

See also **Fashion and Identity; Gender, Dress, and Fashion.**

#### BIBLIOGRAPHY

- Ainley, Rosa. *What is She Like: Lesbian Identities from the 1950s to the 1990s*. London: Cassell Academic Publishing, 1995.
- Blackman, Inge, and Kathryn Perry. “Skirting the Issue: Lesbian Fashion for the 1990s.” *Feminist Review* 34 (Spring 1990): 67–78.
- Chauncey, George. *Gay New York: Gender, Urban Culture and the Making of the Gay Male World, 1890–1940*. New York: Basic Books, 1994.
- Cole, Shaun. *Don We Now Our Gay Apparel: Gay Men’s Dress in the Twentieth Century*. Oxford: Berg, 2000.
- Fischer, Hal. *Gay Semiotics*. San Francisco: NSF Press, 1977.
- Higgins, Ross. “A la Mode: Fashioning Gay Community in Montreal.” In *Consuming Fashion: Adorning the Transnational Body*. Edited by Anne Bryden and Sandra Nieman. Oxford: Berg, 1998.
- Levine, Martin P. *Gay Macho: The Life and Death of the Homosexual Clone*. New York and London: New York University Press, 1998.
- Nestle, Joan. *A Restricted Country: Essays and Short Stories*. London: Sheba, 1988.
- Schuyf, Judith. “‘Trousers with Flies!’: The Clothing and Subculture of Lesbians.” *Textile History* 24, no. 1 (1993): 61–73.
- Trumbach, Randolph. “The Birth of the Queen: Sodomy and the Emergence of Gender Equality in Modern Culture, 1660–1750.” In *Hidden From History: Reclaiming the Gay and Lesbian Past*. Edited by Martin Baum Duberman, Martha Vicinus, and George Chauncey Jr. London: Penguin, 1991.
- Wilson, Elizabeth. “Dyke Style or Lesbians Make an Appearance.” In *Stonewall 25: The Making of the Lesbian and Gay Community in Britain*. Edited by Emma Healey and Angela Mason. London: Virago, 1994.

Shaun Cole

**FASHION AND IDENTITY** Identity is one of the most compelling and contentious concepts in the humanities and social sciences. Fashion becomes inextricably implicated in constructions and reconstructions of

identity: how we represent the contradictions and ourselves in our everyday lives. Through appearance style (personal interpretations of, and resistances to, fashion), individuals announce who they are and who they hope to become. Moreover, they express who they do *not* want to be or become (Freitas et al., 1997). Appearance style is a metaphor for identity; it is a complex metaphor that includes physical features (for example, skin, bodily shape, hair texture) as well as clothing and grooming practices. Because the latter are especially susceptible to change, they are prone to fluctuating and fluid ways of understanding oneself in relation to others within the larger context of fashion change.

Appearance style visually articulates multiple and overlapping identities such as gender, race, ethnicity, social class, sexuality, age, national identity, and personal interests, aesthetic, and politics. Not all of these identities are consciously present at any given moment; power relations influence one’s awareness of one identity or another. Privileged identities (such as whiteness, masculinity, heterosexuality) are often taken for granted as being “normal” or “natural.” But because identities intersect and overlap, their representation is seldom simple. From a cultural studies perspective, identities have not only histories but also futures: They come from somewhere, they are complex and contradictory, and they enable us to express who we might become (Ang 2000).

Expressing who we are and are becoming in words can be a challenge; appearance style seems to offer a way of articulating a statement that is difficult to put into words—that is, emerging and intersecting identities. In fact, it is easier to put into words who we want to *avoid* being or looking like (that is, not feminine, not too slutty, no longer a child) than it is to verbalize who we are (Freitas et al., 1997). Moreover, one identity blurs or blends into another identity (for example, gender into sexuality). And, articulations of identity are often ambivalent. Davis (1992) argued that identity ambivalences provide the “fuel” or ongoing inspiration for fashion change. Fashion-susceptible ambivalences include the interplay between youth versus age, masculinity versus femininity, or high versus low status, among many other possibilities within and across identities.

The study of identity in the social sciences and humanities can be traced to a longer history of the self, personality, and subjectivity, especially in modern Western cultures. Breward (1995) identifies the middle to late sixteenth century as a time when there was a heightened self-consciousness about identity as something that could be individually “fashioned” (p. 69). By the eighteenth century, philosophers (such as Hume and Rousseau) were questioning what constitutes one’s true selfhood, when traditional societies were breaking down (Kellner 1994). (It is important to note that this questioning still assumed the subjectivity of a white, bourgeois male.) Also in the eighteenth century, consumers began to establish

more personalized relationships with individuality, modernity, culture, and clothing (Breward 1995, p.112). For example, the “molly” culture of eighteenth century London provided a means for males to transgress traditional boundaries of masculinity by experimenting with feminine clothing and accessories. By the nineteenth century, consumption linked identity directly to one’s possessions, especially among bourgeois Western women. At the same time, new ways of expressing identifications and disidentifications in city life were emerging (for example, bohemians, dandies; Breward 2003, p. 218).

The modern fashion consumer was moving away “from a concern with elaborate artifice” toward one of individual expression (Breward 2003, p. 200). Crane (2000) describes this as a shift from class fashion to consumer fashion. This was not a smooth process. Modernity itself created fragmentation and dislocation, producing a paradoxical sense of what it meant to be an individual. Wilson (1985) theorizes that a modern sense of individuality functions like a wound that generates fear about sustaining the autonomy of the self; fashion somewhat assuages that fear, while also reminding us that individuality can be suppressed (p. 12).

Although for centuries clothing had been a principal means for identifying oneself (for example, by occupation, regional identity, religion, social class) in public spaces (Crane, 2000), the twentieth century witnessed a wider array of subcultural groupings that visually marked “their difference from the dominant culture and their peers by utilizing the props of material and commercial culture” (Breward 2003, p. 222). In the 1960s, sociologist Gregory Stone (1965) argued that identity has many advantages over the more fixed, psychological concept of personality, and that identity is not a code word for “self.” Rather, identity is an announced *meaning* of the self—one that is *situated* in and negotiated through social interactions. He argued that appearance is fundamental to identification and differentiation in everyday life. The “teenage phenomenon” of the 1950s and 1960s made this very apparent by fostering an awareness of age identity as it intersected with a variety of musical and personal preferences—all coded through appearance styles. The social movements (civil rights, feminist, gay and lesbian rights) of the late 1960s and early 1970s further accentuated stylistic means for constructing and transgressing racialized, ethnic, gender, and sexual identities.

From the post-1960s to the present—a period described as everything from post-industrial to postmodern—an advanced (global) capitalist marketplace has produced an eclectic array of commodities from which individuals can select, mix, and match to produce their identities (Kaiser 1999; Kaiser, Nagasawa, and Hutton, 1991). Wilson (1992) reminds us that despite modern (or postmodern) fragmentation, we ultimately do not choose our bodies, “so postmodern playfulness can never entirely win the day” (p. 8). In the context of ongoing fashion

change, appearance style functions ambiguously both to (a) resist “older” ideas about fixed personality or true self and (b) fix identity (for example, ethnicity, sexuality, religion) more firmly. As the global and local penetrate one another, style and fashion afford strategies for articulating the “contradictory necessity and impossibility of identities . . . in the messiness of everyday life” (Ang 2000, p. 11).

See also **Afrocentric Fashion; Ethnic Dress; Gender, Dress, and Fashion.**

#### BIBLIOGRAPHY

- Ang, Ien. “Identity Blues.” In *Without Guarantees: In Honour of Stuart Hall*. Edited by Paul Gilroy, Lawrence Grossberg, and Angela McRobbie, London: Verso, 2000.
- Breward, Christopher. *The Culture of Fashion*. Manchester, U.K.: Manchester University Press, 1995.
- . *Fashion*. Oxford, U.K.: Oxford University Press, 2003.
- Crane, Diana. *Fashion and Its Social Agendas: Class, Gender, and Identity in Clothing*. Chicago and London: The University of Chicago Press, 2000.
- Davis, Fred. *Fashion, Culture, and Identity*. Chicago: University of Chicago Press, 1992.
- Freitas, Anthony, et al. “Appearance Management as Border Construction: Least Favorite Clothing, Group Distancing, and Identity . . . Not!” *Sociological Inquiry* 67, no. 3 (1997): 323–335.
- Kaiser, Susan B., Richard N. Nagasawa, and Sandra S. Hutton. “Fashion, Postmodernity and Personal Appearance: A Symbolic Interactionist Formulation.” *Symbolic Interaction* 14, no. 2 (1991): 165–185.
- Kaiser, Susan B. “Identity, Postmodernity, and the Global Apparel Marketplace.” In *The Meanings of Dress*. Edited by Mary Lynn Damhorst, Kimberly A. Miller, and Susan O. Michelman. New York: Fairchild Publications, 1999.
- Kellner, Douglas. “Madonna, Fashion, and Identity.” In *On Fashion*. Edited by Shari Benstock and Suzanne Ferriss. New Brunswick, N.J.: Rutgers University Press, 1994.
- Stone, Gregory P. “Appearance and the Self.” In *Dress, Adornment, and the Social Order*. Edited by Mary Ellen Roach and Joanne B. Eicher. New York: Wiley, 1965.
- Wilson, Elizabeth. *Adorned in Dreams: Fashion and Modernity*. Berkeley, Calif.: University of California Press, 1985.
- . “Fashion and the Postmodern Body.” In *Chic Thrills: A Fashion Reader*. Edited by Juliet Ash and Elizabeth Wilson. Berkeley, Calif.: University of California Press, 1992.

Susan B. Kaiser

**FASHION DESIGNER** A fashion designer is responsible for creating the specific look of individual garments—including a garment’s shape, color, fabric, trimmings, and other aspects of the whole. The fashion designer begins with an idea of how a garment should look, turns that idea into a design (such as a sketch), and specifies how that design should be made into an actual



piece of clothing by other workers (from patternmakers to finishers). The category of fashion designer includes people at different levels of the fashion business, from well-known couturiers, to anonymous designers working for commercial ready-to-wear houses, to stylists who might make only small modifications in existing designs. Fashion designers hold a special place in the world. Their talent and vision not only play a major role in how people look, but they have also made important contributions to the cultural and social environment.

### The Origin of Fashion Designers

Charles Frederick Worth is considered the father of haute couture. An Englishman, he opened his couture house in Paris in 1846. Along with Worth, the Callot sisters, Jeanne Paquin, Jacques Doucet, and Jeanne Lanvin are considered to be among the first modern fashion designers, as compared with the dressmakers of earlier generations. Paris was the center of international fashion for more than one hundred years, with French couturiers setting the trends for Europe and the Western world. But the position of Paris as the undisputed leader of fashion was disrupted by World War II.

During that war, with Paris occupied by the Nazis, American designers and manufacturers were cut off from the fashion leadership of Paris. As a result, American designers began to receive more serious recognition. Claire McCardell, known as the creator of the “American Look,” drew some of her inspiration from the vernacular clothing of industrial and rural workers as inspiration. Other American designers such as Hattie Carnegie, Vera Maxwell, Bonnie Cashin, Anne Klein, and Tina Leser had flourishing careers; they helped shape the development of sportswear that reflected the casual American lifestyle.

In the postwar economy, as fashion became big business, the role of the designer changed. Increasingly, especially in the United States, fashion designers worked closely with store buyers to identify customers’ preferences and lifestyle needs. Customer demographics influenced designers to create fashions targeted to specific customer profiles. Through sales events known as “trunk shows,” designers traveled to stores with their latest collection in a trunk. This simple and inexpensive marketing technique allowed customers to preview and respond to the designer’s new collection, and to buy clothes. Bill Blass was one of many designers who used trunk shows to gain customers, profits, and a growing reputation.

### The Role of the Fashion Designer

From the 1950s through the 1980s, the design room in the United States became the equivalent of the European atelier. With a staff of assistant designers, sketchers, patternmakers, drapers, finishers, and sample makers, American designers worked in their design rooms to create a collection each season. “First samples” were produced in the design room and later shown in a fashion show or in

the company showroom. Design rooms are extremely costly to maintain and have been downsized due to the fact that most manufacturing is now done offshore. In the early 2000s, most designers work with an assistant and a technical designer to create tech packs. A tech pack contains a designer’s original idea, which is then re-sketched by the technical designer whose responsibility is to detail all garment specifications and construction information. Tech packs are sent directly to factories in China, Hong Kong, India, or other countries where labor costs are low and where, increasingly, first samples are made and production takes place.

As the apparel industry grew, fashion schools were established to train designers and other industry professionals. Design schools in New York City include Parsons (1896) and Fashion Institute of Technology, or FIT (1914). These schools train students in specializations like children’s wear, sportswear, evening wear, knitwear, intimate apparel, and activewear, for both the men’s and women’s market. Design schools have been established in Paris, London, Antwerp, and throughout Italy. Some American institutions have partnerships with other design schools in China, India, and elsewhere around the world.

Although designers in the twenty-first century are to some extent still responsible for creating trends, the notion of designers dictating fashion has been replaced with lifestyle designing. Each season, designers follow a process of identifying trends and searching for inspiration, researching fabrics and colors. They then focus on creating a collection that will appeal to their specific target customers’ lifestyle. Although fashion trends continue to emanate from Europe, many designers look to the street for inspiration. Fashion designers, working in tandem with the film and music industries, have launched or helped popularize such fashion trends as mod, punk, grunge, hip-hop, and cholo. Fashion designers are both creators and trend trackers. Much of what they now design is a response to street styles.

With the help of marketing and advertising, designers promote themselves to the world. Some designers market their look through runway shows, as well as maintaining their own retail stores. The concept of lending their name to other licensed products is yet another vehicle to expand their brand identity. Many celebrity designers actually do very little designing of the collections that bear their name.

A major trend in the fashion business is the iconic use of sports and music idols to sell product. With the hope of increasing sales, manufacturers hire anonymous designers to create apparel bearing celebrity names. Television, the Internet, personal appearances, film, print ads, and editorial coverage used as marketing tools for fashion, have become as important, if not more so, than the clothing itself. New entrepreneurial designers rely on editorial coverage to launch collections while established



**Edith Head surrounded by some of her fashion designs.** During her 58-year career in Hollywood, Edith Head designed costumes for many films and influenced popular fashion with some of her designs, such as with Elizabeth Taylor's lilac-strewn gown in *A Place in the Sun* (1951). AP/WIDE WORLD PHOTOS. REPRODUCED BY PERMISSION.

companies spend millions of dollars each year on advertising, marketing, and promotion.

Mass retailers and manufacturers enlist the services of market-research firms to predict consumers' changing tastes so as to make appropriate product. Fashion designers utilize data for design purposes that is collected from focus groups and consumer behavior studies. The business of fashion has morphed into the science of fashion.

### The Future of the Fashion Designer

Designers in the twenty-first century are beginning to adopt new technologies such as body-scanning for custom fit, along with seamless and whole garment knitting technologies, which can manufacture garments with the push of a button. Both are forerunners in a movement toward automation that will once again revolutionize the fashion industry. Just as the sewing machine changed the

face of fashion in the past, technology will change it in the future. Designers of the future, as they have in the past, will continue to serve their customer's needs but will do so utilizing new resources and tools. To create new product lines, designers in the future will utilize high-tech textiles, including those that possess healing, sun protection, and other unique qualities. Designing clothes in the future may have more to do with function than with fancy, in response to new consumer demands and preferences.

*See also* Callot Sisters; Color in Dress; Fashion Advertising; Haute Couture; Ready-to-Wear; Worth, Charles Frederick.

### BIBLIOGRAPHY

Baudot, Francois. *Fashion: The Twentieth Century*. New York: Universe Publishing, 1999.

Frings Stephens, Gini. *Fashion: From Concept to Consumer*. 7th ed. Englewood Cliffs, N.J.: Prentice-Hall, 2001.

Payne, Blanche, Jane Farrell-Beck, and Geitel Winaker. *The History of Costume*. 2nd ed. New York: Harper Collins, 1992.

Francesca Sterlacci

**FASHION DOLLS** “Fashion doll” must be considered a very loose term. Sometimes it is used to indicate decorative figures usually produced as a series. Many times they are attired in historical dress. Additionally, notable people dress these dolls for charitable purposes. But there are other candidates for the term as well.

Historically the primary role of a doll has been as a companion and teaching tool for the young. Doll-like figures have additionally played roles in religious, artistic, and fashion-related endeavors. Neither methods nor materials of construction, nor supporting devices, are indicators of possible primary intention. Except for the earliest examples, dolls and figures addressing the subject of fashion range in height from under an inch to, in rare exceptions, nearly three feet.

What in the early twenty-first century might be recognized as a true “fashion doll” were those figures that were sent around to the wealthy and stylish individuals and centers of Europe and, later, American colonies. According to Max von Boehm, the first recorded wardrobe fashion doll—she was life size—went from the French to English court in 1396. By the seventeenth century, when these French figures were known as “Pandora,” the dressing of the head and hair was as important as the garment. And by the eighteenth century the British were not only receiving but also sending their own versions of these figures, which seem from the records to have continued the tradition of being life, or near-life, size. The size perhaps explains why attempts to relate surviving play-dolls from the late seventeenth and eighteenth centuries to fashion dolls has been unsuccessful.

With the introduction of printed images of fashion, the need for the expensive creation and transport of a fashionably dressed three-dimensional figure diminished. Picking up on speed with which printed fashion illustrations could be distributed, French publishers began issuing both boxed sets and serialized accessorized paper dolls. For nearly a generation, circa 1825–1850, this type of doll was an important purveyor of fashion information.

While commercially assembled play-dolls continued to be dressed in current styles, it was not until the mid-nineteenth century that French doll distributors took a renewed interest in offering a variety of outfits and accessories based on the latest modes. Known to doll collectors as French Fashion dolls, these dolls—whatever their body material and articulation—feature a nipped-in waist that makes the dolls suitable for dressing in the

waves of latest fashions for toddlers, children, men, and women between about 1850 and 1900. Produced in a defined section of Paris, most of the apparel for these dolls is so finely constructed that they are truly fashions in miniature, even down to the stamped waistband and hat labels found in Maison Huret apparel.

It was these play dolls that inspired the *Tina Cassini*, a doll whose wardrobe was the creation of the American designer Oleg Cassini, and her contemporary, *Barbie*, the iconic fashion doll of the twentieth century. Not only has *Barbie* been dressed by a studio of personal designers, including Bob Mackie, but other internationally recognized fashion designers from time to time outfitted her and her family for purposes of charity, publicity, and pure promotion. Indeed, since about 1890 French and other fashion designers have dressed dolls in their creations for purposes of international exhibitions and fund-raising. Jeanne Lanvin, in the 1910s, dressed dolls with porcelain heads made by Sèvres, while Margaine-Lacroix dressed those with heads designed by Albert Marque. In the 1930s a consortium of French fashion houses dressed *France* and *Marianne* in up-to-the-minute detail for the British princesses.

On a parallel track beginning in France in the early 1890s was the fashionable dressing of dolls and specifically designed figures solely for the purpose of display and not play. Usually these display figures in series were, in the traditional French manner, attached to a base. The series frequently illustrated the history of fashion especially as drawn from lifetime or imagined portraits of notables, usually women. The trend was begun by Mme Piogey in 1892 with a thousand years of French fashion shown on sixteen dolls, the 1893 Columbian Exhibition display of twenty-five French queens, and the sixteen dolls exhibited by Mme Charles Cousson, whose creations in the early 2000s can be found at Paris’s Musée des Arts Decoratif. Respected museums on both sides of the Atlantic would add such figures to their collection, with New York’s Metropolitan Museum of Art, under the museum’s textile curator, Frances Morris, accessioning the now deaccessioned representations of seven centuries of feminine fashion. As part of the 1949 French Gratitude Train, forty-nine mannequin dolls attired to represent two centuries of French fashion were created, to complement Theatre de la Mode figures by members of the Syndicat de la Couture de Paris. These figures are currently found in the collection of the Brooklyn Museum of Art. In the United States, the tradition of dressing figures in historical fashion has been carried on by a number of artists/designers, including Jacques and France Rommel and John Burbridge.

By the second decade of the twentieth century, the wax-headed figures in contemporary dress of Mmes Lafitte and Désirat were featured in international press. At this time other concerns lured or interpreted the creations of contemporary French designers, such as Jacques Doucet and Paul Poiret. In the early twenty-first century





**Woman with doll collection.** In the 1890s, clothing designers began creating fashions specifically for dolls, often for promotional, exhibition, or fundraising purposes. © BETTMANN/CORBIS. REPRODUCED BY PERMISSION.

the best-recognized effort to document a moment of fashion is found at Maryhill, a school in Oregon. There reside the figures for the Theatre de la Mode created by members of the French haute couture and related trades—Dessès, Molyneux, Grès, Patou, Fath, Balenciaga, Dior, etc. Assembled just after World War II, these figures represent an attempt to remind the world of the artistic uniqueness of all the components of French fashion.

During the American Civil War, as raffle items at Sanitary Fairs, a variety of dolls were dressed and outfitted with complex and elaborate wardrobes. Many of these were called Flora McFlimsey, after the subject of a pe-

riod poem who was convinced she had nothing to wear, thus leading her to undertake frantic shopping trips to Paris. In the early 2000s, such charitable work continued as fashion designers were asked to dress dolls in signature outfits; sometimes they chose the doll, sometimes the doll was chosen for them—which returns this article to the original dilemma of what exactly constitutes a “fashion doll.” Now add to the mix fashion dolls designed specifically for a new category: collectors. Current collectors’ fashion dolls include most prominently those of Mel Odom, *Gene*; and Robert Tonner, *Tyler Wentworth*. These dolls, and their attendant “family” members have

been created specifically as models for high-fashion garments: *Gene*, the World War II and postwar model and *Tyler Wentworth*, the contemporary spirit.

See also **Barbie**.

#### BIBLIOGRAPHY

- Barbie: A Visual Guide to the Ultimate Fashion Doll*. London; New York: Dorling Kindersley, 2000.
- Charles-Roux, Edmonde, et al. *Theâtre de la mode: Fashion Dolls: The Survival of Haute Couture*. Portland, Ore.: Palmer-Pletsch Associates, 2002.
- Mac Neil, Sylvia. *The Paris Collection*. Cumberland, Md.: Hobby House Press, 1992.
- Parrot, Nicole. *Le stiff et le cool: une histoire de maille, de mode et de liberté*. Paris: Nil, 2002.

*Elizabeth Ann Coleman*

**FASHION EDITORS** The title “fashion editor” evokes images of fashionable women, those arbiters of style and taste, who pronounce and decree what’s new and what’s next. They’ve appeared on stage and screen—from the indecisive Liza Elliot of *Lady in the Dark* (“the circus cover or the Easter cover?”) to the very decisive Maggie Prescott of *Funny Face* (“Think pink!”).

With the advent of the fashion magazine, the fashion editor emerged as the tastemaker in the early twentieth century. The first and most enduring of these women was Edna Woolman Chase of Conde Nast’s *Vogue*, who rose from assistant in the circulation department in 1895, three years after *Vogue* was founded, to editor in chief in 1914. She remained in that venerable position until retirement in 1952. Through the 1940s and 1950s, the most visible of her fashion editors was the tasteful and talented Bettina Ballard. An earlier colleague, Carmel White (later Snow) had left *Vogue* to head Hearst’s *Harper’s Bazaar*. Her longtime fashion editor was a flamboyant eccentric (her outrageous column *Why Don’t You ... ?* was notorious) named Diana Vreeland, who in 1963 was tapped by Conde Nast’s new owners to become editor in chief of their flagship, *Vogue*.

These grandes dames of fashion publishing were there at the creation. At first they filled their pages with news of what fashionable and wealthy women were wearing and doing. Actually, they were covering and reflecting their own worlds, as each had come from, or married into, families of wealth and society; and most of their staffers served in their low-paying but prestigious jobs as stop-offs between finishing school and marriage. Coverage of the Paris couture, the wellspring of fashion, and of the emerging American designers established these two magazines as the ultimate authorities—the innovators of fashion and fantasy.

They also discovered and encouraged such talents as Richard Avedon, Irving Penn, Martin Munkacsi, Edward

Steichen, Louise Dahl-Wolfe, art director Alexey Brodovitch, Cecil Beaton, and more. The arts were covered, distinguished writers wrote for every issue, and an environment for fashion was carefully integrated.

By the mid-1950s, a new breed of editor was being sought. The competition coming from the newer, younger fashion magazines devoted to the emerging working woman, the post-war suburbanite, and the “youth market” of the sixties, brought into the editors’ chairs a more pragmatic, reality-based editor. *Vogue* had tapped its merchandizing editor, Jessica Daves, to succeed Mrs. Chase. Diana Vreeland followed as editor in chief, after being passed over at *Bazaar*. Those qualities ultimately did her in at *Vogue*, when she was replaced by her assistant, Grace Mirabella, a down-to-earth market-trained fashion editor. Mrs. Snow’s niece, Nancy White, who’d been editor at Hearst’s service magazine, *Good Housekeeping*, followed her at *Bazaar*.

Of the booming “younger” books, *Mademoiselle*, edited first by Betsy Blackwell, then Edie Raymond Locke, was the first to “merchandise” each fashion shown, informing the reader of its price and where to buy it. *Charm*, *Glamour*, and *Mademoiselle* mounted promotions with editors making appearances in retail stores, as the link between the editorial and advertising departments grew stronger. A fashion editor, covering her assigned market, learned to dutifully cover the advertisers’ “lines.” She even collaborated with designers and manufacturers, developing ideas for new looks for her readers.

Fashion was beginning to reverse itself—starting on the streets and then inspiring designers—so it was important to keep an eye on a magazine’s younger staff and the streets of New York, Paris, Milan, and Saint-Tropez to spot the trends. Paris couture (made-to-order for private customers) no longer dominated; ready-to-wear (prêt-à-porter), started in 1969 in Paris and later in Milan, was manufactured for and sold directly to American and European retailers. These collections became the trendsetters. American fashion editors sat side by side with store executives in the front rows of the overcrowded showings, their photographers jockeying for position along the runways, shooting the photos for the next issue, while space was being held until the last minute before deadline.

The fashion editor’s job was to report the news, making choices from the season’s offerings, whether from Europe or America; to play a major role in the selection of the photographers and models for each “portfolio,” or series of pages; and often to oversee the “sitting” in the studio or the “shoot” on location. High-profile “stars” were Polly Mellen of *Vogue* and Carrie Donovan of the *New York Times*.

New media brought new opportunities, and in the 1980s Elsa Klensch, a former *Vogue* and *Harper’s Bazaar* fashion editor, convinced CNN that women the world over would be eager to view the designers’ collections

within weeks of their showings. Her viewers numbered in the millions, but CNN canceled *Style* in 2000. Successors include *Full Frontal Fashion* and cover not just the collections but the “fashionistas” and front-row celebrities attending.

The technology of the information age has made all things possible on demand. Fashion editors can now view the collections online (not the same as being there in the tents of New York, Milan, London, and Paris); they oversee the selections for their own magazine’s popular Web sites, such as *Vogue’s* Style.com.

Communicating with and serving the reader are duties of today’s fashion editors, who have a whole new world of titles such as “fashion news editor,” “fashion market editor,” “editor-at-large,” “stylist,” and more. Many appear regularly on TV “what’s in” and “how to” segments. They still watch the streets, but mostly they watch the New York and Los Angeles clubs, music videos, and the red carpets to spot the trends. Perhaps the first star of the 2000s is Anna Wintour of *Vogue*, who, in the tradition of earlier grandes dames, pronounces and decrees what’s new and what’s next.

See also **Fashion Journalism; Fashion Magazines; Fashion Online; Fashion Television; Vogue; Vreeland, Diana.**

#### BIBLIOGRAPHY

- Ballard, Bettina. *In My Fashion*. New York: David McKay, 1960.
- Chase, Edna Woolman, and Ilka Chase. *Always in Vogue*. New York: Doubleday, 1954.
- Esten, John, and Katherine Betts. *Diana Vreeland: The Bazaar Years*. New York: Universe Books, 2001.
- Mirabella, Grace, and Judith Warner. *In and Out of Vogue*. New York: Doubleday, 1995.
- Snow, Carmel, and Mary Louise Aswell. *The World of Carmel Snow*. New York: McGraw-Hill 1962.

Lenore Benson

**FASHION EDUCATION** Because the design and retailing of fashion is a global phenomenon, it should come as no surprise that learning institutions around the world prepare graduates for careers in the international fashion industry. Training ranges from vocational to creative to theoretical and results in certificates and diplomas (one to three years), which include associate (two years), baccalaureate (four years), master (master of arts, M.A.; master of fine arts, M.F.A.; and master of sciences, M.S.) and doctoral (doctor of philosophy, Ph.D.; doctor of education, Ed.D.; and doctor of art, D.A.) degrees.

Programs that offer certificates and diplomas tend to exist as part of vocational institutions, and curriculum is focused exclusively on preparing students for industry employment. Baccalaureate programs, in contrast, tend to vary in scope. While some colleges and universities balance a major in fashion design or retailing with re-

quired general or liberal education courses that expose students to a broader worldview, other four-year institutions concentrate solely on the theory and practice of art and design and all curriculum offerings stem from that singular mission. Graduate work is meant to be more focused, and degrees are offered in the areas of retailing, design, textile science, and history. Many universities around the world also offer more flexible graduate programs under such names as Fashion Studies or Clothing and Textiles.

#### Education Options

The fashion industry reaches around the world, with degree-earning opportunities that provide training on every continent in fashion design and retailing.

#### The United States

The United States is home to over 250 institutions of higher learning that include programs in fashion design and retailing. Many of these offerings are housed in colleges or departments that have evolved from the home economics tradition. Consequently, virtually every state in the United States has a university with undergraduate and graduate curriculum in retailing and fashion design. As programs have expanded and contracted, a variety of names have emerged. Such college or department names as Human Ecology, Environmental Sciences, and Family and Consumer Sciences represent a general definition of the changing disciplines included in the mission. Design, Housing, and Apparel, Apparel Merchandising and Interior Design, and Merchandising and Hospitality Management represent more specific program orientation. When searching for fashion design and retailing programs at the university level, these are among the many terms and phrases to consider. Within this type of university system, the retailing or fashion design major program is enriched with required general or liberal education courses that introduce students to a broader perspective on the global community. Students are able to earn a bachelor’s degree, and many departments also offer master’s and doctoral degrees.

Within the United States, there are also colleges, schools, and universities of art and design, with four years of curriculum that refine and focus students’ individual vision and aesthetics related to fashion design, complementing the development of creative skills with an expanded understanding of design theory. Graduates of these institutions have the opportunity to earn a variety of degrees, including an associate of arts (A.A.), bachelor of arts (B.A.), bachelor of fine arts (B.F.A.), master of arts (M.A.), and master of fine arts (M.F.A.) degrees.

In addition, an abundance of vocational and technical schools and art and design institutes offer focused one- to three-year programs in the areas of retailing and fashion design. Degrees earned include associate of arts (A.A.) and associate of applied sciences (A.A.S.), and students are prepared for specific positions within the fashion industry.



**Canada**

Six Canadian provinces have more than ten notable educational institutions that offer programs in fashion design or retailing. Students are able to earn bachelor, master of science, and doctoral degrees within departments of Human Ecology in the general areas of Clothing and Textiles. Bachelor of applied arts or bachelor of design degrees are also available at technical universities. Several vocational and technical institutions offer certificates and two-year diplomas that prepare students for the business and creative sides of the fashion industry.

**Europe**

There are well over one hundred learning institutions in twenty-seven countries across Europe that include fashion design or retailing in their curriculum. Because London, Paris, and Milan continue to function as celebrated international fashion centers, the United Kingdom, France, and Italy warrant individual consideration. There are also significant and interesting educational opportunities in Scandinavia, Central and Eastern Europe, and the other Western European countries.

**United Kingdom.** With London as one of the premier world fashion centers, it makes sense that more than forty educational institutions offering programs in fashion design or retailing are situated throughout England, with one or two in Scotland, Wales, and Northern Ireland. Learning opportunities range from vocational and technical training to prestigious art schools and universities. Completion is designated by National Diploma/Certificate (ND/C), generally a one-year technical degree; Higher National Diploma (HND), an additional year beyond earning of a certificate; and Bachelor of Arts Honors (B.A. Hons.) or Bachelor of Science Honors (B.S. Hons.), typically a three- or four-year advanced degree comparable to a four-year degree earned at a U.S. institution. Master and doctoral degrees can be earned at a few institutions, including more traditional university systems as well as those focused specifically on art and design.

**France.** Paris is home to France's five premier learning institutions with programs in fashion design and retailing. Two institutions offer curriculum in English and are organized for international students who desire short-term (four weeks) or long-term (three years) study-abroad opportunity in the areas of retailing or fashion design. Certificates and bachelor degrees can be earned, and credits may be transferred to colleges and universities at both the graduate and undergraduate levels. The other specialized schools are organized in the manner of art and design schools and offer one-, two-, or three-year programs in textile design and fashion design.

**Italy.** Italy has more than twenty design and retailing academies and institutes scattered around the country, with several more prominent programs in such vibrant international fashion centers as Florence, Milan, and Rome. Students are presented with a range of opportu-

nities: one-, two-, three-, and four-year programs, summer short courses, workshops, and practical training in all facets of the fashion industry. Several academies offer programs of varying lengths for international students who choose to study fashion in Italy. All programs, regardless of length, are part of academies or institutes that focus solely on the practical and theoretical aspects of design and retailing. Many of the learning institutions are directly linked with professionals in the Italian fashion industry, providing students with opportunities to train and network with potential employers.

**Other Western European countries.** While not as heavily concentrated, over thirty-five institutions offering fashion design and retailing are distributed throughout the remainder of Western Europe in such countries as Austria, Belgium, Germany, Greece, Ireland, the Netherlands, Portugal, Spain, and Switzerland. Diplomas, bachelor, and a few graduate programs are available throughout the region.

**Central and Eastern European countries.** There are several opportunities for earning degrees in retailing and fashion design in such countries as the Czech Republic, Estonia, Hungary, Latvia, Lithuania, Poland, Romania, Russia, Slovakia, Slovenia, and the Ukraine. Lithuania, Poland, Slovakia, and Russia have particularly impressive and extensive offerings, with bachelor and graduate programs.

**Scandinavia.** Scandinavia has long enjoyed a rich craft tradition, which continues to be nurtured through university curriculum offerings. Norway, Sweden, and Denmark have institutions that offer two- and four-year degrees in both fashion and textile design. In Finland, students can earn bachelor, master, or doctoral degrees in textiles, clothing, or craft design within such departments as Textiles and Clothing and Home Economics and Craft Science.

**Asia**

Fashion education is prominent and tremendously active in China, India, and South Korea and is the focus of this section. However, exciting educational opportunities also exist in Japan, Malaysia, Philippines, Singapore, and Vietnam.

**China.** Including the People's Republic, Taiwan, and Hong Kong, China has much to offer in the educating of professionals in the areas of clothing design and textile technology. Students are able to earn certificates and diplomas, bachelor of arts, bachelor of science, masters, and doctoral degrees at several institutions. Some institutions focus on textiles and apparel programs that include studies in textile science and textile technology. College names such as Home Economics and Human Ecology emerge in institutional literature, suggesting that some Chinese clothing and textiles programs are modeled after U.S. offerings.

**India.** The country of India is a hotbed of international apparel and footwear manufacturing companies. Educational institutions have responded to the need to train professionals and over fifty-five institutions offer programs in fashion design and retailing. The majority of curriculum focuses on fashion design and technology, although a few programs offer degrees focused on the business side of the apparel industry. Degree opportunities range from technical diplomas and certificates in such areas as apparel production competencies (garment fabrication, sketching, cutting, tailoring, embroidery, and computer-aided design [CAD]) and fashion retail management, to four-year bachelor degrees in fashion design.

**South Korea.** Within South Korea, more than forty universities and colleges offer two-year, four-year, master's, and doctoral degrees in the areas of fashion design and retailing. These programs emerge from such divisions as Human Ecology, Home Economics, Clothing and Textiles, Fashion Design, and Fashion Marketing. Two- and four-year degrees prepare students for careers in the textile and apparel industry. Graduate curriculum focuses specifically on textile and apparel industry issues, including technological expertise and economic trends.

### Oceania

There are more than twenty institutions located in the Oceanic region, with programs that focus on fashion design, retailing, and textile technology. Australia boasts several programs with certificates and diplomas, bachelor's, master's, and doctoral degrees. New Zealand is home to a dozen universities, institutes of technology, polytechnics, and colleges of art and design with a focus on fashion design and retailing. A degree in apparel merchandising and fashion design is also available in Papua New Guinea. Within these Oceanic countries, certificates and diplomas are earned in such areas as clothing production, textiles, footwear production, and fashion design. Bachelor of science degrees are available in Textile and Apparel Management and bachelor of arts degrees are available in Fashion and Textile Design.

### Other World Locations

Iraq, Israel, Saudi Arabia, and United Arab Emirates in the Middle East; Argentina, Brazil, Chile, Uruguay in South America; Mexico in North America; and the African countries of Congo, South Africa, and Zimbabwe also have universities and colleges that offer stimulating two- and four-year degrees in fashion design and fashion marketing.

### Conclusion

This overview on fashion education reveals three important points: (1) fashion education is offered on every continent around the world, (2) training professionals for the international apparel industry takes many forms, and (3) there exists a reciprocal relationship between the inter-

national fashion industry and educational training in the areas of fashion design and retailing. In geographic regions around the world where design is celebrated, there are fashion design schools (Italy, France, and England). Locations with a multitude of apparel manufacturing sites tend to be breeding grounds for training in technical and creative competencies (China, India, and South Korea). Educational institutions continue to recognize and address the essential needs of the fashion industry.

*See also* **Fashion Advertising; Fashion Designer; Fashion Editors; Fashion Illustrators; Fashion Industry; Fashion Journalism; Fashion Models; Fashion Photography.**

### BIBLIOGRAPHY

*The World of Learning: The Definitive Guide to Higher Education World-wide.* London: Europa Publications, 2003.

#### Internet Resources

*Education Institutes in India: Fashion and Design.* 2003. Available from <<http://www.webindia123.com/career/fashion/list.asp?action=Fashion+Technology>>.

*International Directory of Design.* 2003. Available from <<http://www.penrose-press.com>>.

*International Textiles and Apparel Association Directory.* 2003. Available from <<http://www.itaaonline.org>>.

Jane Hegland

**FASHION, HEALTH, AND DISEASE** The relationship between fashion and health is a complex one, with fashion sometimes being shaped by current beliefs about health and disease and, at other times, acting as the cause of illness.

### Early Beliefs

For many centuries, those in the Western world believed that human illness was primarily related to the disposition of "humors," vapors coming from deep inside the body and released at the skin surface (Renbourn and Rees 1972, p. 401). The ancient Greeks believed that a damp, cold environment prevented these humors from passing out through the skin, being turned back instead toward the internal organs. There, they caused inflammation and every imaginable disease. The belief that damp cold was almost solely responsible for most human illness persisted until the middle of the nineteenth century, when the science of bacteriology began to link disease to the spread of infectious organisms.

The fear of damp cold led to multiple theories about dressing for health. There was, of course, the fear that the very clothing worn to protect the body from damp cold, could itself block the passage of humors outward. Arguments were made in favor of each of the natural fibers as being the most healthy to be worn, with wool being believed by many to be the most healthy because it was found to be the greatest absorber of water.

The human body does actually release vapors from the skin surface in a continual drying out of the skin called insensible perspiration. Research in the mid-1800s established for the first time that wool had the ability to absorb insensible perspiration and later condense it under cooler conditions, sending the resulting heat from condensation back toward the body (Renbourn and Rees, p. 40). Cotton and linen appeared to have no such capacity to produce heat; they continued to cool until dry, leading to a dangerous chilling of the body.

These findings caused many health practitioners to advocate wool in the years that followed. One, a German physiology professor named Jaeger, touted his all-woolen system of dress as the key to revolutionizing the health of all ages in all climates (Renbourn and Rees, p. 46). Many believed that wool also served as a “filter” to prevent impurities from reaching the body. Wool later was discovered to have another prized quality—it retained an electric charge. In the middle of the eighteenth century, many believed that a strong positive electrical charge led to male virility (Renbourn and Rees 1972, p. 33). During the nineteenth century, electric and magnetic garments were in vogue, and statically charged undergarments were credited with having powers from curing rheumatism to affecting the bowels (Renbourn and Rees, p. 39).

Wool, however, had its detractors, particularly among those who worked and lived in the tropics. A number of physicians in the seventeenth and eighteenth centuries noted that because wool was not easy to clean, it housed and propagated fleas, lice, and other carriers of disease. Excessive swaddling of infants in wool in the tropics by British nurses working there was thought to be one cause of infant mortality. Many believed cotton to be healthier than wool in warm climates because it provided more continual cooling and was more easily cleanable and less irritating to the skin.

From the seventeenth to nineteenth centuries, an almost irrational fear of exposure to drafts existed in many countries. Exposure to air currents was believed to be responsible for a wide range of conditions, including head colds, sore throats, and rheumatism. This concern contributed to excessive coverage of the body, even in warmer weather. During the French Revolution, when women ignored traditional admonitions for body coverage, the supposed link between diseases like consumption and revealing garments made of the sheer muslins of the time even led to new labels, such as “muslin disease” and “pneumonia blouses” (Renbourn and Rees, p. 34).

Color was believed to have had magical properties that affected human health. Various colors have been thought to best intercept dangerous rays of the sun or attract or repel toxins. While there has been considerable debate about the importance of specific hues in protecting the body, many cultures that exist in desert climates have long accepted that most whites and lighter colors

reflect more sunlight than most blacks and darker colors. The white robes of desert dwellers, for example, offer thermal protection by reflecting the radiant heat of the sun away from the body.

### **Fashion as Detriment to Health**

One of the main reasons early fashion was detrimental to health was that dressing in many layers and bathing infrequently combined to make clothing a breeding ground for infectious organisms and vermin. Some fashions also seemed to attract infected refuse. A medical paper of 1900 reported on a bacteriological examination of the trailing voluminous skirts of the time in which the author “found large colonies of germs, including those of tuberculosis, typhoid, tetanus, influenza” (Rudofsky 1947, p. 181).

Fashion has often involved modification of the body. The professed reasons for this range from ceremonial to practical, among them: influencing the morality of a wearer’s behavior, communicating social status, increasing sexual allure, and establishing an aesthetic ideal. Harold Koda states that “Shoes have been the most persistent example of fashion’s imposition of an idealized form on the natural anatomy” (2001, p. 140). He notes that the portion of the shoe that contained the toes has rarely, if ever, reflected the shape of the human foot but that the shape of a shoe, “consistently worn eventually molds the foot” (p. 140).

There has been much controversy about the health effects of modified feet. The most extreme example of foot modification is the Chinese bound, or lotus, foot. Dorothy Ko states that while Chinese footbinding shifted the placement of the bones of the foot, it broke no bones. It simply shortened the length of the foot and changed the locus of its support of body weight (p. 60). Many lotus shoes were designed to allow the axis of support of body weight to pass through the heel alone, alleviating any painful pressure on the folded toes (p. 152). Koda states that the spiked heel that was first made popular in the 1950s has acted to place the foot of its wearer in almost the same vertical position as the lotus foot. (2001, p. 159). In addition to precipitating ankle injury, the “tip-toe” stance of the foot in high heels “has been known to shorten the leg muscles, and in creating a destabilized stance, it can precipitate problems at the small of the back” (p. 163).

In the nineteenth century, physicians argued that the “wasp waist” of the corseted woman was detrimental to health, producing various conditions such as fainting, cracked ribs, miscarriage, difficulties in breathing, and abnormally functioning internal organs (Renbourn and Rees 1972, p. 11). More recent research on the effects of the corset have found few, if any, permanent health effects for adult women once a corset is removed (Steele 2001). However, Steele acknowledges that because corsets interfered with respiration, they did create “a disincentive” for Victorian women to exercise (p. 71). Indeed, one of fashion’s primary negative effects on health



in the past may have been limiting the types of activities in which individuals have felt able to participate.

### Current Approaches

The belief that cold, damp weather and exposure to drafts are responsible for the common cold and flu has persisted to modern times, despite the assertions of clothing physiologists that “cold stress” is only one of dozens of stresses of modern life that lead to these illnesses.

During the second half of the twentieth century, dressing to protect the body from thermal conditions in the environment generally involved one of two approaches: using clothing to insulate the body against sudden heat loss or using it to shield the body from excessive heat gain. While much has been made of the healthful effects of specific fibers, it is well accepted that the fiber used in garments is only one factor in the ability of clothing to provide thermal balance. Watkins cites multiple factors: the fiber, yarn type, fabric construction, fabric finish, garment design, and the way of wearing a garment (1995, p. 26). Even when the same garments are worn in a different layering order, or freed or tucked in differently, the thermal balance of the wearer can be greatly affected.

New processing methods for fibers and fabrics have markedly improved insulation materials, and a variety of methods of protecting insulations from wind and water have emerged. The development of a material with micropores, Gore-Tex, in the mid-twentieth century brought the advent of waterproof materials that “breathe.” These fabrics exclude liquid water, but allow vapor such as insensible perspiration to migrate out of an ensemble. Supple aluminized coatings on materials enable the reflection of radiant heat from the sun, fires, or high-heat industrial settings.

Despite technological advances that have created the potential for healthy clothing, some cultural norms may still dictate the use of garments that negatively affect health. Muslim women continue to wear the chador, the heavy, full-length veil that has been said to have caused fainting and serious long-term health problems such as osteoporosis. Western men continue to wear improperly sized business shirts with collars that cut off proper blood flow, leading to a variety of conditions from fainting to decreased visual acuity (Langan and Watkins 1987).

Other cultural norms focus on what is believed to be healthier approaches to dressing. Some Western professionals wearing high fashion walk to the office in running shoes, donning fashionable footwear only for meetings. Elderly women in nursing home wheelchairs are increasingly seen, not in the socially acceptable dresses from their pasts, but in nonbinding jogging suits.

The growing interest in alternative medicine has also revived a number of clothing practices that have met with great skepticism in the past. Experiments with the effect of color on the immune system continue. Proponents be-

lieve that magnetic clothing items may relieve pain and cure a number of different conditions. Citing new evidence relating copper to the body’s enzyme production, proponents have revived interest in copper jewelry as a cure for arthritis.

### The Future

Clothing has been designed to shield the body from all sorts of hazards of modern life. During the Gulf War in 1991, it was not unusual to see Israeli civilians of all ages carrying gas masks as constant accessories. Filtration masks to prevent the spread of respiratory diseases or protect asthmatics from pollution have become familiar sights. The U.S. Occupational Safety and Health and Administration (OSHA) has established educational programs to teach laborers who work with toxic chemicals the dangers of exposing the skin and respiratory system to those hazards and help them select appropriate protective suits and respirators. Space suits have been miniaturized to allow immune-deficient patients to venture into the world. Sheer, supple stainless-steel undergarments have been marketed particularly to pregnant women who work at computers, to protect them from electromagnetic radiation. There are few occupational hazards for which health-protective apparel has not been developed. Many of these have been reshaped into fashionable forms; others themselves establish a new fashion aesthetic.

All of these approaches to protection are essentially passive design concepts, working to shield the body somehow from the environment. Advances in technology are making it increasingly possible to use active approaches to protection, where clothing contributes to thermal balance or other forms of protection. For example, electrically heated and water-cooled systems have existed for decades, but the increasing miniaturization of power sources will make these more available and easily incorporated into everyday clothing. Clothing fibers have been impregnated with chemicals that absorb body heat when the wearer is warm and release it when the body begins to cool. These advances allow clothing to serve not just as a barrier, but as an active provider of thermal balance without an external power source.

Some proposed clothing designs incorporate mechanisms that will massage and stimulate blood flow to an ailing body part or trigger an automatically inflated airbag should the wearer start to fall. Others, for example a wristband worn to prevent seasickness, simply help the body heal itself, operating on centuries-old knowledge based on alternative treatments such as acupuncture.

Garments have been impregnated with bacteria-detering agents to actively fight organisms that attempt to make their way toward a wearer. Undergarments have been developed that monitor multiple aspects of body function and send signals that stimulate medical devices or trigger the release of medications into the body. Many of these have been connected to computerized body-monitoring systems allowing clothing to respond

automatically to each individual's needs. These garments allow patients formerly tied to hospital beds to move into the world. Many are wireless, so that doctors can monitor a patient's health at a distance and make adjustments in treatment accordingly. As the body's most intimate environment, clothing has enormous potential to help individuals meet the health challenges of the future.

See also **Color in Dress; Corset; Footbinding; High Heels.**

#### BIBLIOGRAPHY

- Ko, Dorothy. *Every Step a Lotus*. Berkeley: University of California Press, 2001.
- Koda, Harold. *Extreme Beauty*. New York: Metropolitan Museum of Art, 2001.
- Langan, Leonora, and Susan Watkins. "Pressure of Menswear on the Neck in Relation to Visual Performance." In *Human Factors* 29 no. 1 (1987): 67–72.
- Renbourn, E. T., and W. H. Rees. *Materials and Clothing in Health and Disease*. London: H. K. Lewis and Company, 1972.
- Rudofsky, Bernard W. H. *Are Clothes Modern?* Chicago: Paul Theobald, 1947.
- Steele, Valerie. *The Corset*. New Haven, Conn.: Yale University Press, 2001.
- Watkins, Susan. *Clothing: The Portable Environment*. Ames: Iowa State University Press, 1995.

Susan M. Watkins

**FASHION ICONS** The term "fashion icon" has recently replaced the slightly antiquated notion of "fashion leaders." During the second half of the twentieth century, fashion became less hierarchical, more meritocratic, and media-dominated. Indeed, the media itself created its own icons of style, while scrutinizing those proffered up by journalists, stylists, and others involved in the professional process of promoting fashion. The "trickle-down," designer-led fashions of the past were joined by the concept of "bubble-up," where fashions are created on the streets and fed upward through the fashion system. "Style is not fashion until it has reached the street," is a statement popularly attributed to Coco Chanel, herself a leader; she was also part of the democratization of fashion.

The "fashion leaders" of past generations were those in the very highest society—royalty, aristocrats, and their wives and mistresses. The Bourbon courts of pre-Revolutionary France were famous for their fashion excesses, while in the 1790s Napoleon's wife, Josephine, embraced the new "Empire-line dresses," which quickly crossed the Channel. In England, at precisely the same moment in history, the Prince Regent, who gave his name to an architectural style, was consorting with the dandies of the day, including the famous Beau Brummel.

At the start of the twentieth century, magazine journalism had been enlivened by still photographs, and cin-

ema was in its infancy. Much of the newsreel footage from the first decade of the new century showed King Edward VII and his elegant wife, Alexandra; many of his mistresses were also fashion leaders, such as Madame Stan-dish of Paris, who was the first to wear the new "tailor-mades" by Creed to the Paris racecourse; and Lillie Langtry, the music-hall actress, who was a favorite of the popular press. It was her amply curved figure that was the fashionable silhouette, as seen in the popular illustrations of the "Gibson Girls," created by the American, Charles Dana Gibson.

Chanel set up her fashion business before World War I and, in its aftermath, a radically altered society found her designs suited its new needs. During the War, many women had experienced the freedom of wearing trousers for manual work—and freedom of movement was Chanel's aim. She liked wearing men's sweaters and put women in soft jersey and fluid garments. She popularized costume jewelry, the little black dress—and the suntan. She was emulated in every way, and when she came back from the Riviera to display her suntan at the Opera, a new craze began.

The war annihilated a generation of young men; the women who survived wanted to forget, rather than to mourn. Economic independence and changing mores meant new fashion icons were needed for the 1920s—the "Bright Young Things" of London and the stars who personified the Jazz Age: Clara Bow, the "It Girl" of cinema; and the idol of Paris, singer Josephine Baker. In the Roaring Twenties, too, stage actresses—such as Gertrude Lawrence—were still relevant; they, too, had shingled hair, short skirts, and cigarette holders.

There was still a role for royalty—men and women were fascinated by the dress of Edward, Prince of Wales, and his Oxford bags, plus fours, and Argyle sweaters were widely copied. He even had a fabric pattern named after him—Prince-of-Wales check. His long-term mistress, Freda Dudley Ward, embodied the flapper look of the 1920s, but in the following decade he abandoned her to marry the stylish American divorcée, Wallis Simpson. It was she who formulated the fashion dictum, "A woman can never be too rich or too thin." Although the public was distressed by his abdication, they nevertheless bought mass-market copies of her Molyneux wedding dress.

Technological changes now meant that fashions could be copied at moderate prices, and, at last, ordinary women could copy their icons. This was the decade when Hollywood moguls allowed women to imitate the dresses of their favorite stars, as well as their makeup—Adrian's outfits for Joan Crawford were highly influential, and Travis Banton's dressing of Marlene Dietrich made trousers seem sexy rather than merely functional. Joan Crawford's famous puff-sleeved dress, created by Adrian for the film *Letty Lynton* in 1932, was instantly copied, and inspired young girls' party dresses for the next ten years. Dietrich in *Morocco* (1930) was the first woman to

don men's evening wear, and created a sensation when she appeared on screen in her tuxedo and top hat.

World War II meant fashion was curbed—and economic recovery was slow in the postwar period of shortages and rationing. The most famous couture collection ever was Dior's New Look of 1947, with its long skirts and nostalgic elegance—it filtered down to high-street level and was popular well into the 1950s with Hollywood costume designers. Edith Head dressed leading stars Grace Kelly, Audrey Hepburn, and the young Elizabeth Taylor in outfits inspired by the New Look.

The 1950s saw a sea change with the advent of youth-oriented fashions, linked to music and to the newly discovered and largest consumer group, the “teenagers.” Economic power meant that young people wanted their own fashions and music, and their own icons. Marlon Brando created a particular look with his T-shirt in *A Streetcar Named Desire* (1951) and his leather jacket in *The Wild One* (1953). James Dean put the two together—as did Elvis Presley. The changing mood was reflected by the antifashion look of Brigitte Bardot in *And God Created Woman* (1956)—with untidy hair, short cotton dresses, and bare feet, she was the antithesis of groomed Hollywood glamour.

Jackie Kennedy presented a very different fashion picture in the early 1960s; copies of her suits, dress-and-coat outfits, and pillbox hats were very popular. But taste had changed—and fashion became, for the first time, completely youth-led, with London at the epicenter of the “youthquake.” Models such as Jean Shrimpton and Twiggy, film stars like Julie Christie and, above all, musicians, were the new icons. Whether dressed in sharp suits, like the Beatles, or wearing their own eclectic mix of clothes, like Jimi Hendrix and Keith Richards of the Rolling Stones—whatever they did was picked up immediately. Designer Ossie Clark famously dressed Mick Jagger in a white tunic and trousers in 1969, and in the 1970s the male stars of “glamrock” wore makeup.

The economic difficulties of the 1970s produced the hedonism of Studio 54—where Bianca Jagger appeared, attired by Halston—and the confrontational androgyny of punk. In 1977, the Sex Pistols wore clothes designed by Vivienne Westwood—torn, provocative, and fetishistic.

In the 1980s, as economic prosperity returned, so did conventional icons, like the young Princess Diana, and more glamorous icons; the “supermodels” were dressed and lionized by Gianni Versace. Rap stars, like Run-DMC, made active sportswear fashionable; designers copied their look. In the 1990s, there was a need for less “glitzy” icons; fashion followed music into “grunge,” photographers like Corinne Day created “waifs” such as Kate Moss, and sports stars became emblems of style. In 2003, there is no shortage of icons—“celebrity culture” has provided, perhaps, too many. This could mean that the notion of a “fashion icon,” like that of a “fashion leader,” needs to be redefined.



**Jacqueline Kennedy.** Though she was First Lady for only a few years, Jackie Kennedy's modern elegance had a long-lasting influence on the fashion world. © UPI/CORBIS-BETTMANN. REPRODUCED BY PERMISSION.





### JACKIE KENNEDY

Jacqueline Lee Bouvier was born into a wealthy family and raised to a life of privilege. Her 1953 marriage to Senator Jack Kennedy at the wealthy enclave of Newport, Rhode Island, was one of the most glittering social events of the decade. Mrs. Kennedy became a popular figure during the 1960 presidential campaign; after her husband's election, her beauty, love of clothes, and sense of style set her apart from her rather plain predecessors as First Lady, Bess Truman and Mamie Eisenhower. Criticized in some quarters for wearing European fashions, she patronized American designers, particularly Oleg Cassini (whose designs, however, owed much to European originals). Her inauguration outfit of a fawn-colored woolen coat with matching pillbox hat was instantly copied by thousands of women; a red dress (by Chez Ninon after a Marc Bohan for Dior original) that she wore for a televised tour of the White House became another iconic "Jackie Look."

In 1968, five years after her husband's assassination, Mrs. Kennedy married wealthy Greek shipowner Aristotle Onassis; after his death in 1975 she returned to New York City and lived there until her death in 1994. Throughout those years she dressed with elegance and style; but her time as a true fashion icon came during her brief years in "Camelot," the Kennedy White House.

See also **Actors and Actresses, Impact on Fashion; Celebrities; Fashion Models.**

#### BIBLIOGRAPHY

- Bailey, David, and Peter Evans. *Goodbye Baby and Amen*. London: Conde Nast, 1969.
- Beaton, Cecil. *The Glass of Fashion*. London: Weidenfeld and Nicholson, 1954.
- Bruzzi, Stella, and Pamela Church Gibson. *Fashion Cultures: Theories, Explorations, Analysis*. London: Routledge, 2000.
- Garland, Madge. *The Changing Face of Fashion*. London: Dent and Sons, 1970.

*Pamela Church Gibson*

**FASHION ILLUSTRATORS** Fashion illustration, although often considered quaint and recherché, cannot, in fact, be separated from the development of printing technologies and the growth of fashion journalism.

The appearance of the first costume books (records of regional and ethnic dress) in the sixteenth century, is linked, as Alice Mackrell confirms in her book, *An Illustrated History of Fashion*, to: "The invention of movable printing types by Johannes Guttenberg in Munich in 1454" (p. 14). The development of engraving techniques further propagated the distribution of fashion art, even as the computer is doing today.

The advent of fashion photography, however, has had as great an impact on fashion illustration as any printing technologies. Today, illustration exists in a symbiotic, and secondary, relationship to the lens, where once it was king.

Photography—no matter how altered or retouched—has become irrevocably equated with what is real and true. The photographic image is seen to provide a "customer service"—to show the clothes, just as the fashion plate once did. In contrast, in the twentieth century, fashion illustration has become more and more expressive, conveying an idea or an attitude, the fragrance of a look, as it were.

In some ways the predominance of photography is very logical. During a time of fashion dictatorship (through the 1950s) fashion illustration existed alongside photography as a sort of couture art form that mirrored in many ways the production, presentation, and style of the clothes. The 1960s' emphasis on youth and street influences was well suited to the immediacy of photography and its by-now iconic pioneers, like the rough-and-tumble David Bailey—type parodied in Michelangelo Antonioni's *Blow-Up*. Illustrators, in contrast, are mostly anonymous, working as they do, alone.

The all-star list of fashion artists might be topped by the seventeenth-century artists Jacques Callot (1592–1635) and Abraham Bosse (1602–1676), both of whom exploited improving engraving techniques to produce realistic details of the clothes and costumes of their times. A litany of fashion magazines appeared between the seventeenth and nineteenth centuries in France and England—among them *Le Mecure Gallant*, *The Lady's Magazine*, *La Gallerie des Modes*, *Le Cabinet des Modes*, and *Le Journal des dames et des modes*—all of which propelled the fashion plate to its nineteenth-century efflorescence.

The fashion plate, which captured trend-driven information as well as provided general dressmaking instruction, came into its own in the eighteenth century, flourishing, finally, in *fin de siècle* Paris. A shining example of this flowering is Horace Venet's *Incroyables et Merveilleuses*, a series of watercolor drawings by Venet of fashions under Napoleon I, engraved by Georges-Jacques Gatine as a series of fashion plates. France's position as the arbiter of fashion insured that there was a constant demand, at home and abroad, for fashion illustration. This demand was met by such talented artists as the Colin sisters and Mme. Florensa de Closménil.

The focus of nineteenth-century illustrators was on accuracy and details. They conformed to static, iconographic conventions in order to provide information and instruction to their viewers. In contrast, contemporary fashion illustration, which dates to the turn of the twentieth century, is highly graphic and focuses more on the artist's individual filter of the world. For example, Charles Dana Gibson's (1867–1944) scratchy renderings of the modern American woman, with upswept hair and shirt-waist, defined a type as well as provided a humorous, sometimes satirical, commentary on contemporary American life.

In Paris, Paul Poiret was commissioning limited edition albums by artists like Paul Iribe (1883–1935), known for his jeweled-tone palette and clean graphic line, as pure artwork. In this way Poiret aligned his new uncorseted and exotic silhouettes with the elite and exclusive world of art.

Iribe was part of a cabal of fashion illustrators who contributed to the celebrated *La gazette du bon ton*, which was published from 1912–1925 and included work by such greats as: Charles Martin (1848–1934); Eduardo Garcia Benito (1892–1953); Georges Barbier (1882–1932); Georges Lepape (1887–1971); and Umberto Brunelleschi (1879–1949). The now highly collectible plates they produced for the gazette show the influence of Japanese wood-block prints as well as the new sleek geometry of Deco styling.

*Vogue* and *Harper's Bazaar* magazines also kept the art of fashion illustration alive, featuring from about 1892 through the 1950s the work of fashion illustrators like Christian Berard (1902–1949), Eric [Carl Erickson] (1891–1958), Erté [Romain de Tiroff] (1892–1990), Marcel Vértes (1895–1961), René Bouché (1906–1963), and René Gruau (1908–). Berard and Vértes in particular are famous for their friendships and collaborations with designers such as Coco (Gabrielle) Chanel and Elsa Schiaparelli, who also worked with fine artists like Jean Cocteau and Salvador Dalí (who illustrated several *Vogue* covers). Both Berard and Vértes had a soft line, similar to that of Andy Warhol's fashion illustrations. René Gruau, on the other hand, is famous for his work for Christian Dior. His bold calligraphic style is among the most distinguished of the first half of the twentieth century.

One illustrator dominated the century's second half: Puerto Rican-born Antonio Lopez (1943–1987). Inspired as much by the street as by experiments with art historical styles (Deco, Op, etc.) his sensual renderings of personalities from friends like Pat Cleveland and Jerry Hall to urban break-dancers, all drawn from life, had relevance and resonance even in a photographic age. "When Antonio died," says fellow illustrator Tobie Giddio, "it's as if he took illustration with him."

Indeed, in spite of the contributions of artists like Jeffrey Fulvimari, Joe Eula, Lorenzo Mattotti (1954–), Mats Gustafson (1951–), Thierry Perez, and Tony Viramontes (1960–1988), the métier was not to see a re-

vival of any scale until the 1990s. However, *Vanity*, a short-lived illustrated magazine founded in Milan by Anna Piaggi (for which François Berthoud [1961–] illustrated most of the covers), deserves mention.

Credit for a renewed interest in illustration at the turn of the twenty-first century goes to Barneys New York for their 1993–1996 advertising campaign. Conceived of by Ronnie Cooke Newhouse, with copy by Glenn O'Brien and squiggly, indeterminate—yet biting satirical illustrations—by Jean-Philippe Delhomme (1959–), these bizarre advertisements stood in direct, and effective, contrast to the aesthetics of the time, especially the super-model phenomenon and the penchant for the grungy, often androgynous "heroin chic" look.

The next blip in the history of contemporary fashion illustration came via a lifestyle—not a fashion—book: Tyler Brulé's *Wallpaper\**. In *Wallpaper\** illustration was considered an extension of design, and the magazine's out-sized pages were given over to such talents as Anja Kroenke, Liselotte Watkins, and the magazine's illustrative mascot of sorts, Jordi Labanda. Fashion magazines, with the notable exception of *Vogue Italia*, which often features the work of Mats Gustafson, the Swedish-born master of minimalism, continue to relegate illustration to spots—often on cooking or horoscope pages. *Vogue Nippon*, founded in 2000, also proves an exception to the rule, favoring the work of such artists as Ruben Toledo and Piet Paris.

Most recently, illustration has come into vogue through collaborations between designers and illustrators/artists. Marc Jacobs at Louis Vuitton has partnered with Julie Verhoeven and Takashi Murakami, and Stella McCartney with David Remfy.

At the turn of the twenty-first century, illustration is being revolutionized by technology—again—this time via the computer. While the late nineties saw the rise of slick computer-based drawing by such pioneers as Ed Tswaki, Graham Rounthwaite, Jason Brooks, and Kristian Russell, there has been a backlash in favor of work that is, or looks like it is, hand-drawn. Charles Anaste's realistic, biographical illustrations are much in demand, but so are the hyperrealist work of René Habermacher, the surreal stylings of Richard Gray, and Julie Verhoeven's erotic fashion drawings. Mixed media work is also popular, as virtual collages are made possible by new technology.

Technology's greatest impact, though, is on the actual production of artwork. What fashion illustration is, must be reconsidered. It is a strange, strange irony, too, that the fashion plate, an early form of fashion illustration, was mechanically produced and hand-colored, whereas contemporary illustration usually starts with a hand sketch and is finished—and colored—by hand. "I am curious about what is going to happen," muses Habermacher, whose work fully exploits digital processes. "In recent years," he said, "I have realized that the direction of my work is different from what you can

describe as classical fashion illustration. Continuing on that road will necessarily lead to a new definition.”

However difficult a definition of fashion illustration might be, its existence, and importance, is without question. The world has need of what art director Davis Schneider refers to as “visual luxuries”—illustrated fashion art.

See also **Barbier, Georges; Fashion Plates; Fashion Magazines; Fashion Models; Fashion Photography; Iribe, Paul.**

#### BIBLIOGRAPHY

- Borrelli, Laird. *Fashion Illustration Now*. London: Thames & Hudson, Inc., 2000.
- Holland, Vyvyan. *Hand Coloured Fashion Plates: 1770–1889*. London: B. T. Batsford, Ltd., 1955.
- Mackrell, Alice. *An Illustrated History of Fashion: 500 Years of Fashion Illustration*. New York: Quite Specific Media Group Ltd., 1997.
- Packer, William. *Fashion Drawing in Vogue*. London: Thames & Hudson, Inc., 1989.
- Steele, Valerie. *Paris Fashion*. New York: Oxford University Press, 1988.
- Weill, Alain. *Paris Fashion: La gazette du bon ton: 1912–1925*. Paris: Bibliothèque de l'image, 2000.

Laird Borrelli

**FASHION INDUSTRY** The fashion industry is unique from other fields of manufacturing in that it is ruled largely by the same intention as its end product: change.

What defines the fashion industry is largely based on the functions of the individuals who comprise it—designers, stores, factory workers, seamstresses, tailors, technically skilled embroiderers, the press, publicists, salespersons (or “garmentos”), fit models, runway models, couture models, textile manufacturers, pattern makers, and sketch artists. In simplest terms, the fashion industry could be described as the business of making clothes, but that would omit the important distinction between fashion and apparel. Apparel is functional clothing, one of humanity’s basic needs, but fashion incorporates its own prejudices of style, individual taste, and cultural evolution.

The notion of fashion as solely fulfilling a need is past, as the modern apparel industry finds its purpose in the conception, production, promotion, and marketing of style on the basis of desire. It reflects the changing wants of consumers to be defined by their attire, or more commonly to be accepted, which has precipitated change throughout fashion history—from iconic silhouettes referred to in the patronizing language of the early twentieth century, the Gibson Girls and Floradora Girls, to the enlightened New Look (a term coined by Carmel

Snow, the editor of *Harper’s Bazaar*, in 1947) and evolving right on through an ever-changing lexicon of haberdashery. Changing styles always necessitate change through industry, notably in the ever-specialized fields of manufacturing and merchandising, as well as through the promotion of designs and designers, expanding their scope into what are known in the early 2000s as “lifestyle brands,” encompassing more than just fashion—incorporating the vernacular of fragrance, accessories, home furnishings, automobiles, jewelry, and writing instruments as well.

Even limited to the business of making clothes, its components have continually adapted to the changes of fashion and prevailing consumer demands, whether for casual clothes or formal suits, American sportswear, or celebrity-endorsed street wear. Over the decades, crinoline makers have become bra manufacturers, suit makers have adapted to the rise of separates, and textile mills have discovered the comfort of stretch. Meanwhile, new advancements in fabric development, manufacturing, and information management have become as important commodities as cotton and wool in the ever more complicated and competitive field. Throughout it all, the industry has developed classifications of pricing and style to facilitate its basic functions of designing and selling clothes along the traditional dividing line of wholesale and retail, one that has become much less distinct in recent years.

Following the traditional view of fashion’s infrastructure, as referenced in the textbook *The Dynamics of Fashion*, there are four levels of the fashion industry: the primary level of textile production, including mills and yarn makers; the secondary level of designers, manufacturers, wholesalers, and vendors; the retail level, which includes all types of stores and distribution points of sale; and also a fourth level—the auxiliary level—which connects each of the other levels via the press, advertising, research agencies, consultants, and fashion forecasters who play a part in the merchandise’s progression to the end consumer. While the relationship between the levels is more or less symbiotic—they need one another to survive—historically, the competitive spirit of capitalism has also created a tension between retailer and manufacturer, where the balance of power is usually tipped to one side in the race to capture profits and margins. The degree to which each side benefits financially from the sale of apparel has changed gradually over the decades, subject to many factors from social advancements to economic swings to cults of designer personalities to wars—both between countries and conglomerates. Over the century, the retailer, in many cases, has taken on the role of the manufacturer, and manufacturers have become retailers of their own designs.

The mass production of clothing began roughly in the mid-nineteenth century, when some manufacturers began to produce garments that did not require fitting, but fashion did not become an established industry in the



institution sense of the word until the twentieth century, when networks of neighborhood tailors casually evolved into manufacturing businesses, factories grew from necessity during the world wars, and the ensuing social and cultural changes signified the dawn of less restrictive and unilateral codes of dress. Changes in the business of fashion, and the establishment of designers as arbiters of taste, began to take shape in the early part of the century, although largely led by European houses. As the French designer Paul Poiret said during a presentation at the Horace Mann School in 1913, “Elegance and fashion have been the pastime of our ancestors, but now they take on the importance of a science” (quoted in *Women’s Wear Daily* in its ninetieth anniversary issue, 16 July 2001).

Just as French couture houses were beginning to gain an international reputation in the late nineteenth century, following the styles introduced by Charles Worth, Jeanne Lanvin, Paquin, and Poiret, the fast rise of garment factories, meanwhile, was largely an American phenomenon. It was most visible as an industry in New York City, where more than 18,000 workers were employed in the manufacture of blouses by 1900 at the time of the founding of the International Ladies Garment Workers Union (ILGWU), a precursor to the modern-day apparel union UNITE (Union of Needletrades, Industrial and Textile Employees), formed in 1995 with the merger of the Amalgamated Clothing and Textile Workers Union. The rapid shift of custom-made to ready-made clothes during the industrial revolution was stimulated by the growth of the middle class and a large increase in foreign labor, mostly Jewish and Italian immigrants who brought their tailoring skills from Europe and first organized themselves in tenements on the Lower East Side. However, the immigrant connection and overcrowded conditions generally associated with the industry led to zoning restrictions that quickly pushed production from apartment buildings into lofts and away from increasingly sophisticated showrooms. For twenty years, manufacturers continued to migrate north and west, often driven by law, such as when the Save New York Committee campaigned to move apparel factories out of the neighborhood known as Madison Square—where Broadway and East 23rd Street converge—because of fears that the factories would be a detriment to the atmosphere of nearby Fifth Avenue, known as the Ladies’ Mile.

Working conditions declined as manufacturers took advantage of the increasing pools of immigrants, influencing the rise of sweatshop labor as well as the move to unionize workers. The industry grew exponentially—by 1915, apparel was the third largest in America, after steel and oil. The Triangle Shirtwaist fire of 1911, in which 146 workers were killed, had finally led to the regulation and scrutiny of garment industry working conditions.

The industry moved again beginning in 1920, when two sites along Seventh Avenue between 36th and 38th Streets were developed by the Garment Center Realty Co., an association of thirty-eight of the largest women’s

clothing makers, sparking the first influx of apparel businesses in a neighborhood that has become the early twenty-first-century home to New York’s garment district. Yet change is still occurring, as most production has moved offshore to factories in cheaper locales and many designers have moved their offices to more “refined” neighborhoods away from the bustle of rolling racks and button shops.

In the 1930s, though, as the unified center for garment production, and the most highly concentrated apparel manufacturing capital in the world by this point, Seventh Avenue from 30th to 42nd Streets began to reflect the need for categorization within fashion. Although the industry can broadly be divided into two primary functions—wholesale and retail—the growing prevalence of department stores necessitated further distinctions. Certain buildings, in a tradition that continues in the early 2000s, house bridal firms, and others specialize in furriers, dress vendors, or coat companies, and within those categories grew distinctions of price or targeted demographic. The modern industry divides its pricing into four general categories of moderate, better, bridge, or designer apparel, from the least to most expensive, and within those categories are even more specialized distinctions, such as the relatively new silver and gold ranges (for prices that are too high to be considered bridge or too low to be called designer). There are also categories geared toward types of customers, such as juniors (a more generic classification for sportswear in the 1960s that is used to define teen-oriented labels), contemporary (geared toward young women and relating commonly to smaller sizes), and urban (reflecting the growing market for street wear).

For much of the twentieth century, the industry continued its evolution along familial lines, as the descendants of poor immigrants who had once operated those small factories along Orchard and Mulberry Streets on the Lower East Side began to establish serious businesses on Seventh Avenue, along with impressive fortunes behind companies with names that were for the large part inventions. Apart from the few pioneers of the first half of the century—Adrian, Bonnie Cashin, and Claire McCordell among them—the personalities behind the American fashion industry operated largely in anonymity compared with their counterparts in Paris, where Coco Chanel, Alix Grès, and Madeleine Vionnet had already become celebrities of international acclaim. Until World War II, it was common for American manufacturers to travel to the seasonal Paris shows, where they would pay a fee known as a caution to view the collections, usually with a minimum purchase of a few styles. They were legally permitted to copy these styles in the United States, where department stores began a tradition of lavishly presenting their copied collections with their own runway shows.

In the 1950s and 1960s, however, a growing number of entrepreneurial designers—many striking out in

the business following their service in the war—began to make their way out of the backrooms to feature their own names on their labels, a development facilitated in part by the curiosity of the press and also by the ambitions of manufacturers to capitalize on designer personalities. Licensing a designer name into other categories became a common practice, and by the 1980s, propelled by an economic boom, designers had become celebrities—led by such ambitious and charismatic personalities as Oscar de la Renta, Bill Blass, Calvin Klein, and Halston. Meanwhile, the advent of the modern designer business stood in stark contrast to the overall industry, which remained largely characterized by independent companies, with as many as 5,000 businesses then making women's dresses, helmed by a prosperous but aging second generation. Since the 1980s, the apparel industry has come to be defined by consolidation, globalization, and the economics of publicly traded companies, where the biggest news stories have been the rush of many designers to Wall Street and the retail industry's continual merging into only a handful of remaining department store companies—giants encompassing the majority of retail nameplates.

Change continues to come. The fashion industry of the early 2000s is global, with luxury conglomerates taking stakes in American businesses and production constantly moving to countries that offer the most inexpensive labor. Garments are conceived, illustrated, and laser-cut by computers, and replenished automatically by a store's data system alerts. Designers compete directly with their biggest customers by opening flagships around the world, and stores compete with designers by sourcing and producing their own private label collections, often based on the prevailing runway looks. Magazine editors and stylists have gone on to become designers, while Hollywood actors and pop stars have gone from wearing designer clothes to creating them. At the outset of the twenty-first century, what defines the fashion industry has little to do with the artisan's craft of a century ago, but would be better described as the pursuit of profitable styles by multinational conglomerates with competitive technology and the most efficient delivery of timely merchandise.

But change in fashion—or the fashion industry—is nothing new. It seems fitting to refer to the opening line on page 1 of the first issue of *Women's Wear Daily*, which was founded as *Women's Wear* in June 1910, in response to the rise of the women's apparel industry: "There is probably no other line of human endeavor in which there is so much change as in the product that womankind wears."

See also **Economics and Clothing; Fashion Education; Fashion Marketing and Merchandising; Globalization.**

#### BIBLIOGRAPHY

Friedman, Arthur. "New York's Lucky Seventh." *WWD Century, Women's Wear Daily Special Edition* (September 1998): 162.

———. "Garment Town's Rise to Fashion Avenue." *WWD Ninety, Women's Wear Daily Special Edition* (16 July 2001): 226.

Stone, Elaine. *The Dynamics of Fashion*. 2nd ed. New York: Fairchild Publications, 2004.

Stegemeyer, Anne. *Who's Who in Fashion*. 3rd ed. New York: Fairchild Publications, 1996.

Wilson, Eric. "The Early Years." *WWD Ninety, Women's Wear Daily Special Edition* (16 July 2001): 58–60.

Eric Wilson

**FASHION JOURNALISM** Until Virginia Pope of the *New York Times* made fashion the topic of serious newspaper coverage with the attendant responsibilities for accuracy, objectivity, and fairness, the words "fashion journalism" were an oxymoron.

During her tenure at the *Times* (1925–1955), she raised the bar not only for fashion journalism, reporting on the Paris haute couture collections beginning in 1934 in addition to her regular New York coverage, she also introduced the idea of live theatrical fashion presentations, which she produced for the public each fall under the auspices of the *Times*.

Many other U.S. papers of that era ran occasional photos of the latest Paris creations and counted on their society editors to report on who-wore-what to the local charity ball. There was little or no regard for the business of fashion, its sociological implications, or news from designers.

In 1943, the New York fashion publicist Eleanor Lambert, who represented many New York designers of that era, initiated "press weeks," inviting fashion editors from newspapers throughout the country to attend capsule presentations of her clients' collections—showings that took place in New York hotel meeting rooms months after those same collections had opened to buyers in Seventh Avenue showrooms. Similar "press weeks" were held in Los Angeles, sponsored by the California Fashion Creators, a loose coalition of designers there.

The general tenor of the fashion writing in the 1940s and early 1950s was a labored accounting of skirt lengths, jacket cuts, color choices, and fabric descriptions. In 1956, Eleanor Nangle of the *Chicago Tribune*, together with fashion editors from the *Milwaukee Journal* (now the *Milwaukee Journal Sentinel*), the *Buffalo News*, and the *Fort Worth Star-Telegram* decided that fashion should be covered as sports are covered—at the time the games are played, in this case, at the time the seasonal collections opened to buyers, and not from hotel suites months later. (New York papers had "always" covered the showroom openings, but the out-of-town press had not, as few newspapers considered fashion an important enough subject to justify the expense of a week in New York.)

Lambert's press weeks continued, but more and more fashion editors from metropolitan newspapers began to attend the buyer openings and report, on the spot, from New York. And as they came, their competitors followed. A few—the *New York Times*, the *New York Times Magazine*, the *New York Herald-Tribune*, the *Chicago Tribune*, the *Washington Post*, the *Boston Globe*, the *Chicago Sun-Times*, and the *Los Angeles Times*—also reported on the Paris haute couture openings, as did the trade publication *Women's Wear Daily*.

Eugenia Sheppard, then at the *New York Herald-Tribune* and later at the *New York Post* and *Women's Wear Daily*, was one of the first to make fashion writing entertaining. She also proved her resourcefulness as a journalist by once sneaking into a Balenciaga show as a buyer in order to get immediate coverage. (Balenciaga and Hubert de Givenchy showed one month after the other couturiers and put embargos on news coverage for a month after their openings.) Her coverage got her banned from the next season's show, but she managed to cover that one, and others from which she would eventually be barred, by interviewing buyers who were in attendance. Such ingenuity also made her one of the first to be a fashion journalist celebrity.

By 1969, Paris ready-to-wear was becoming more and more important to American retailers, and newspaper fashion editors gradually started reporting on these twice-yearly events, later expanding that coverage to include Florence, Milan, and London. One editor, Nina Hyde of the *Washington Post*, made an exceptional contribution to fashion journalism by her efforts to discover new talent.

Bill Cunningham, first a columnist for *Women's Wear Daily* and later a freelance contributor to the *Chicago Tribune*, *Los Angeles Times*, and *Details* magazine, was the first fashion photojournalist to point out design copying. His photos of original designs juxtaposed with his photos of the copies left readers of *Details*, the *Los Angeles Times*, and the *Chicago Tribune* with little doubt of the design's provenance, and his witty texts became classroom examples of how to make fashion writing interesting. Cunningham's photo essays of the New York fashion scene for the *New York Times* are a weekly documentary of what real people really wear on the streets and in the social arena.

That so much fashion coverage in the 1970s, 1980s, and 1990s centered on the seasonal shows in Europe was a reflection of the Eurocentric nature of fashion at that time. The news—the trends that set the scene for the direction of fashion—was, for the most part, coming from Paris, Milan, or London. Americans were generally known as fashion marketers or stylists. Europeans, especially Paris designers, were the *créateurs*. As some have said: Americans make clothes; Europeans make fashion.

Increasingly aware that a lot of the fashion space they usually garnered was being taken by the European coverage, New York designers began to join the trend to

more theatrical shows by leaving their showrooms in favor of larger hotel venues. Many upgraded their presentations from models instructed to bring their own shoes and the announcing of style numbers to buyers seated in rented-for-the-day little gold chairs to choreographed shows with music, never-seen-before, never-worn-before accessories crafted especially for the collection, hair and makeup professionals creating beauty looks, backstage booze, and, eventually, “supermodels.”

In 1980, television fashion coverage, which until then had been limited to an occasional fashion “special,” makeovers, and sixty seconds or so at the end of a morning show during collection openings, got its biggest boost when Elsa Klensch went on the air for CNN, her shows televised around the world. Given her international audience and her interviewing style—always respectful, never critical—Klensch was able to attract all the top designers for interviews and to gain access to their shows. For the first time, a viewer could watch the runway shows of all the major fashion players in New York, Tokyo, Paris, Milan, London, and Klensch's native Australia. *Style with Elsa Klensch* truly brought fashion to the masses. When the show was discontinued in 2000, it had an estimated 120 million viewers in 210 countries. *Edie Raymond Locke's Show* was another groundbreaking TV show from that time (1981–1986). The show was hosted by Edie Raymond Locke, who brought the magazine format she had pioneered as editor-in-chief of *Mademoiselle* magazine to USA Network. Her half-hour weekly shows concentrated on fashion, beauty, decorating, finances for women, makeovers, and model of the month. In the early 1990s, Geoffrey Beene became the first American designer to forsake the runway for the stage—first a *mise-en-scène* at Lincoln Center, then Broadway-type shows at the Equitable Building with elaborate stage sets, music created just for the show, and models interspersed with ballet dancers.

By 1993 the Council of Fashion Designers of America (CFDA) decided to try to compete with the European cities as a fashion capital by creating 7th on Sixth (7th on Sixth was the CFDA's way of saying Seventh Avenue—typically known as Fashion Avenue—had moved over a block to Sixth Avenue where Bryant Park is located) and producing shows under tents in Bryant Park. As the showmanship increased, fashion coverage increased, and designers attracted movie and rock stars to sit front row, some exchanging clothes for appearances. Journalists from Europe and Japan attended, providing a global audience for New York designers, a few of whom had begun to sell to European stores and open their own boutiques there. Madonna became a regular. Barbra Streisand, Whitney Houston, David Bowie, Mariah Carey, Lenny Kravitz—all brought their star power to the tents, juicing the entertainment element and thereby increasing newspaper readership and television viewers. The Bryant Park shows inspired a television show, *Full Frontal Fashion*, which went on the air with New York's Metro Channel in 1998, featuring footage taken during



the shows and designer interviews, many of them with the show's founder, Judy Licht. Producer John Filimon says the object of the show, which was being broadcast on the WE channel in the early 2000s, was, and is, to make the designer the star.

During the 1980s and 1990s, most newspaper fashion editors had a laissez-faire approach to their coverage, writing about trends rather than critiquing individual collections. The exceptions, notably Eugenia Sheppard, Hebe Dorsey of the *International Herald Tribune* and her replacement Suzy Menkes, and Amy Spindler and Cathy Horyn, the first and second fashion critics at the *New York Times*, treated (and treat) the subject of fashion, especially the openings, as critics covering other fields would do—with opinions as well as facts.

The role of fashion journalism has obviously changed with the times. It also changes with the type of medium involved. Most magazine fashion editors do not write. They cover markets, making recommendations to the top editors for specific garments for specific shoots, and they style photography. The oldest fashion magazines, *Vogue* and *Harper's Bazaar*, have traditionally defined their fashion coverage not only by their audience demographics—upper-income adults—but also by their conviction that fashion begins in Europe and is homogenized in America. By encouraging American designers to “adapt” the designs of Cristóbal Balenciaga, Jacques Fath, and Christian Dior, for example, editors in the 1930s, 1940s, and 1950s discouraged design innovation in America, effectively relegating the New York designer to the backrooms of Seventh Avenue. And until the mid-1980s and 1990s, before it joined Paris, Milan, and London as a fashion capital, New York was generally considered a digester of fashion, not a feeder. The media effect of those two magazines, plus the editorial slant of *Women's Wear Daily* during the years John Fairchild was publisher, was to place Europe at the top of the fashion chain and to convince many American designers that their role was to assimilate, not innovate.

In many respects, Fairchild revolutionized the way fashion was covered—with great irreverence. He and his staff mixed fact with opinion, encouraged controversy, baited designers, followed them, scared them, coined phrases (“the lunch bunch” was code for rich socialites), made some of them heroes and destroyed others. *WWD*, as it is known, even created a new syntax, using . . . as a way of separating thoughts instead of as an ellipse to indicate an omission.

Like magazine fashion coverage, television fashion coverage is more subject-friendly than confrontational or critical. The entertainment element is fundamental.

In many ways, the advent of television fashion coverage has influenced fashion in a way few predicted. As Malcolm McLaren was quoted as saying in the May 1995 issue of *W Magazine*: “Fashion is a television spectacle now. But at the same time, it has become voyeuristic. Be-

cause if people watch it enough, and read about it enough, to some extent they don't have to wear it. They've already consumed the idea.” This raises the question: Is the widely circulated immediate coverage of the seasonal openings giving people too much advance knowledge of the season and thereby making the clothes look old by the time they reach the stores?

The Internet's biggest impact on fashion journalism in the early twenty-first century is to enable users to see images of the collections here and abroad and read capsule reviews within hours after the runway show. For manufacturers inclined to copy, this is a great service. For designers eager to see what their competition is doing, it is far more valuable than an occasional photograph in a newspaper or trade publication. For consumers eager to see for themselves what lies ahead, and thereby help them plan their seasonal purchases, it is a boon. For someone hoping to see the season synthesized and trended, it is a boondoggle. For journalists who cover the shows and for stylists who will be responsible for accessorizing the clothes with the point of view of their magazine or their advertising client, it is a quick reference for planning future stories or avoiding the seasonal clichés. For magazine editors accustomed to making their own runway sketches as notes, it is a great backup.

With the beginning of fashion on television, some, like McLaren, were concerned with its potential long-term impact on the subject. The same questions are being asked now about the Internet. Fashion can now be conveyed in a variety of ways, from print to live satellite feeds to video conferencing with designers.

The question now remains: Why does a fashion journalist have to be there—wherever *there* is—to get the story?

See also **Fashion Advertising; Fashion Designer; Fashion Magazines; Fashion Models; Fashion Online; Fashion Shows; Fashion Television.**

#### BIBLIOGRAPHY

Wood, Dana. “Modus McClaren.” *W* (May 1995): 49.

Marylou Luther

**FASHION MAGAZINES** Fashion magazines are an essential component of the fashion industry. They are the medium that conveys and promotes the design's vision to the eventual purchaser. Balancing the priorities has led to the diversity of the modern periodical market.

Fashion, except in its lifestyle sense or as a byword for vanity, played no part in early periodical literature. In 1678, however, Donneau de Visé first included an illustrated description of French fashions with suppliers' names in his ladies magazine, *Le Mercure galant*, which is considered the direct ancestor of modern fashion reports. Thereafter, fashion news rarely reappeared in periodical literature until the mid-eighteenth century when it was

included in the popular ladies handbooks and diaries. Apparently in response to readers' requests, such coverage to the popular *Lady's Magazine* (1770–1832) was added to the genteel poems, music, and fiction that other journals were already offering to their middle-class readers.

By the end of the eighteenth century, *Lady's Magazine* had been joined by many periodicals catering to an affluent aspirational society. Interest in fashion was widespread and it was included in quality general readership journals such as the Frankfurt *Journal der Luxus und der Moden* (1786–1827) and Ackermann's *Repository of the Arts, Literature, Commerce, Fashion and Politics* (1809–1828) as well as those specifically for ladies. Despite the continental wars, French style was paramount and found their way into most English journals. Very popular with dressmakers was *Townsend's Quarterly (later Monthly) Selection of Parisian Costumes* (1825–1888), beautifully produced unattributed illustrations with minimal comment. The journals were generally elite productions, well illustrated and highly priced, though cheaper if uncolored. John Bell's *La belle assemblée* (1806–1821) was edited by Mary Anne Bell between 1810 and 1820, also proprietor of a fashion establishment. Dressmaker's credits are rare, perhaps because fashion establishments were dependent on personal recommendation and exclusivity.

By the middle of the nineteenth century, the magazine, like other popular literature, profited from improvements in printing methods, lower paper costs, and lower taxation. Literacy levels had risen and readership increased. Many new titles were produced and fashion for all types and ages were generally included in those for the women's market. Circulation figures were high; *Godey's Lady's Book* (1830–1897) issued 150,000 copies in 1861 and Samuel Beeton's *The Englishwoman's Domestic Magazine* (1852–1897) issued 60,000. Advertisement increased but the revenue rarely inhibited editorial independence. The key to circulation was innovation, and Godey and Beeton both added a shopping service and additional paper patterns to those already available within the magazine. Up-to-date fashion news was an essential and fashion plates as well as embroidery designs came direct from Paris sources, though in America they were often modified for home consumption.

The wide-ranging informative articles, typical of the "new journalism" were often written by women beginning to be well established in the newspaper profession. By the end of the century, there had been women editors at *Godey*, the Demorest publications, 1860–1899, *The Queen* (c. 1860s) and *Myra's Journal of Dress and Fashion* (1875–1912).

Entertaining and practical guides for the average family, this type of mid-market magazine had a long life, only recently losing its popularity. Its main competitors were shop catalogs and store magazines.

High-fashion Paris news was most easily accessible in the large format society journals, the weekly illustrated



**Former *Cosmopolitan* editor-in-chief Helen Gurley Brown.** *Cosmopolitan* was originally conceived for the whole family, but when Brown took the reins in 1965, she reformatted it into a woman's magazine. AP/WIDE WORLD PHOTOS. REPRODUCED BY PERMISSION.

newspapers, and *La mode illustrée* (1860–1914), of which there was an English edition. Semi-amateur fashion cum gossip columnists were a feature of Gilded Age society, but the couture concerned with their expanding international market were increasingly professional about their publicity, and well-kept house guard books were probably as useful for press promotion as they were to designers and clients.

Through its *Chambre Syndicale*, the couture was organizing its own fashion journal, *Les modes* (1901–1937). Its innovative and informative photographic illustrations made it an anthology of high status Paris design by the end of the century. In 1911 Lucien Vogel offered the couture an even more modern shop window in the elitist *Gazette du bon ton* (1911–1923), the precursor of the small *pochoir* (stencil) illustrated fashionable journals



**1929 *Vogue* cover.** Revamped by Condé Nast in the early twentieth century, *Vogue* is global in its coverage of the world of high fashion. © CONDÉ NAST ARCHIVE/CORBIS. REPRODUCED BY PERMISSION.

characteristic of the avant-garde press of the early twentieth century.

It is a tribute to their vision that a men's style publication was included. *Monsieur* (1920–1922) was a complete break with the stereotyped format and trade jargon of the tailoring journals. It was not followed until *Esquire* (1933–), described as the male counterpart to *Vogue* and *Harper's Bazaar*, updated the male fashion image, stressing a harmony between clothes and lifestyle.

High fashion was reinterpreted for the American market when *Vogue* was taken over by Condé Nast Publications in 1909. His publishing experience had shown that a rich and aspirational American society wanted practical fashion guidance and a direct line to Paris. *Vogue* coverage is global in the early 2000s, and foreign editions make their own assessments of the fashionable and the salable. Until his death in 1942, Condé Nast maintained meticulous control of the quality and service he believed were owed to his readers. *Vogue* archives provide insight into the management of quality fashion publication in a twentieth-century world. The contributors, editors, designers, photographers, and artists who have enriched the *Vogue* pages over the years add another essential layer of information.

As fashion pace increased, the fashion publication scene was stimulated by developments at *Women's Wear Daily* (*WWD*), after the Fairchild family purchased it in 1909 as a conventional trade paper for the garment trade. Its offshoot, *W* (1972–) was developed by John Fairchild, the son of the founder, to have “the speed of a newspaper . . . with the smart look of a fashion magazine” and significantly, its survival depended on advertisement. News “scoops” were competed for ruthlessly. *Vogue* secured the designs for Princess Elizabeth's wedding dress in 1947, *WWD* obtained Princess Margaret's in 1960, plus the annual Best-Dressed List. Assessment of style change was more problematic and it was the role of the fashion editor to balance designer's contribution and public acceptance. It was a tribute to both when magazines and public supported Dior's New Look in 1947, despite trade and government opposition.

Increasingly dependent on advertising, the conventional magazine is challenged if fashion deviates from established trends. The “lead in” time for a quality, full-color journal is generally two months—too long for the speed of street fashion and its high-spending, young, and trendy clientele. This readership was not targeted until 1976 when Terry Jones, originally from *Vogue*, developed the U.K. magazine *i-D*, with its apparently spontaneous fanzine look. Its original message, “It isn't what you wear but how you wear it,” had little appeal for the clothing trade but it has found its niche market in the early 2000s and is the prototype “young fashion” magazine.

Despite the number of fashion magazines currently available, it is probable that most people appreciate fashion through the daily press, the popular lifestyle and celebrity magazines, television, and the Web. With advertising pressures and the sheer volume of clothing choices in an affluent society, it is not unexpected that these popular magazines react by judging celebrities not by their designer clothes, but by the way that they wear them.

See also **Vogue; Women's Wear Daily.**

#### BIBLIOGRAPHY

- Breward, Christopher. “Feminity and Consumption: The Problem of the Late Nineteenth Century Fashion Journal.” *Journal of Design History* 7, no. 2 (1994): 71–89. Perceptive survey of late nineteenth-century editorial attitudes.
- Fairchild, John. *Chic Savages*. New York: Simon and Schuster, 1989. Personal account of *Women's Wear Daily* and *W*.
- Finley, Ruth E. *The Lady of Godey's: Sarah Josepha Hale*. Philadelphia and London: J. B. Lippincott, 1931. Useful for early American periodical publishing history.
- Seebohm, Caroline. *The Man Who Was Vogue*. New York: Viking Press, 1982. Full biographical account of Condé Nast.
- White, Cynthia L. *Women's Magazines 1693–1968*. London: Michael Joseph, 1970. Clear account based on U.K. sources.

Madeleine Ginsberg



**FASHION MARKETING AND MERCHANDISING** The goal of fashion marketing and merchandising, for both manufacturers and retailers, is to sell merchandise at a profit. This requires careful planning and coordination.

In ancient times, people “shopped” in open-air markets and bazaars, finding not only necessities but also products that were unique and gave excitement to their everyday lives. Today, we shop and buy in much the same way, but open-air markets and bazaars have evolved into department and specialty stores, discount outlets, and huge malls that continue to excite and entice the shopper. The difference is that fashion marketing and fashion merchandising are now the watchwords of successful fashion businesses. In the early twenty-first century, the customer has become the most important ingredient in successful fashion retailing. Determining the needs and wants of the targeted customer has become very important, and this challenge has led to the creation of specific goods and stores for specific categories of customers.

For many years, fashion producers were concerned only with what was economical and easy for them to produce. They would spend considerable time and money trying to convince the consumer that what they produced was what the consumer wanted. The fashion producer had little or no interest in the needs and wants of the consumer. However, marketing proved so successful in the growth of consumer goods such as automobiles, packaged foods, and health and beauty aids that it was eventually adopted by the fashion businesses. Under the classic definition of marketing, the key task of the organization is to determine the needs and wants of target markets and adapt the organization to deliver the desired satisfactions more effectively and efficiently to the ultimate customer.

Through the use of sophisticated marketing techniques such as focus groups, surveys, data mining, and market segmentation along with systematic approaches such as electronic data information (EDI), inventory tracking, and constant evaluation of advertising results for determining consumer tastes, the industry’s awareness of the importance of pleasing the target customer has greatly increased. Every step—design, production, distribution, promotion—is geared to consumer demand.

“Fashion marketing” includes all of the activities involved from conceiving a product to directing the flow of goods from producer to the ultimate customer. Activities of marketing include product development, pricing, promotion, and distribution. If a fashion retailer or manufacturer is to make a profit, the firm must have a product that consumers perceive as desirable, and the product must be presented to potential customers in a way that makes them want to buy it.

The first step in a fashion marketing approach is to define the company’s target customers, those persons the company most wants to attract as customers. Fashion

marketers determine their target customer’s needs and wants by examining various market segments, identified by geographics, demographics, psychographics, and behavioral studies. Fashion marketers also track trends in population growth and diversity. Changing patterns of immigration bring with them new influences from different parts of the world. Products that will meet the needs and desires of these customers are then developed or selected. Most fashion manufacturers and retailers recognize that following a consumer-marketing approach leads to a profitable business.

“Fashion merchandising” is defined as the buying and selling of goods for the purpose of making a profit. Merchandising is the planning involved in marketing the *right* merchandise at the *right* price at the *right* time in the *right* place and in the *right* quantities. Commonly known as the 5Rs, merchandising is concerned with all the activities necessary to provide customers with the merchandise they want to buy, when and where they want to buy it, and at prices they can afford and are willing to pay. This includes making buying plans, understanding the customer, selecting the merchandise, and promoting and selling the goods to the consumer.

Fashion merchandising is practiced by both manufacturers and retailers. For manufacturers, merchandising begins with estimating consumer demand in terms of styles, sizes, colors, quantity, and price. Merchandising also involves designing the goods and selecting the fabrics and findings, designing the packaging, pricing, advertising, and other sales promotion activities.

For fashion retailers, merchandising also begins with forecasting the needs and wants of their target customer. The retailer must first project sales in terms of dollars and units of merchandise. Just as the manufacturer must anticipate the needs of the retailer, the retailer must also anticipate the needs of the consumer by reviewing past sales, keeping up on trends, and knowing where on the fashion cycle their customer falls. The retailer must also know what colors, sizes, styles, and prices of merchandise that their target customers want to purchase. After planning what and how much to buy, merchandising for the fashion retailer includes determining resources from which to purchase, selecting from their assortments, and purchasing the goods for sale to the consumer. Another factor of merchandising is presenting the merchandise attractively and effectively to the consumer and promoting the merchandise so that the target customer will want to buy it.

In the early 2000s, technology has been a major factor in helping fashion manufacturers and retailers to successfully satisfy the needs and wants of the targeted customer, with body scanning being just one example. Body scanning software customizes patterns for an individual’s body. This results in the kind of fit previously available only to couture customers. As technology continues to improve and become less costly, scanning of the

entire body will become more common, resulting in the kind of fit previously available only in expensive made-to-measure fashion products.

The development of fashion marketing and merchandising as distinct professions with their own expertise, insights, and techniques, has made them the cornerstone of the modern world of fashion. The use of sophisticated marketing and merchandising methods and techniques has given rise to some of the most exciting and innovative strategies: among them are entertainment-oriented shopping malls, themed environments, designer and manufacturer retail flagship stores, brands, off-site retailing and e-tailing and packaging, now viewed as the science of temptation.

Fashion marketing and merchandising present a unique problem because of the ever-changing nature of fashion and the difficulty of predicting consumer demand. The fashion world is famous for its fast-moving, do-or-die success or failure rate. With a need to respond quickly to consumer purchasing, sophisticated processes are required for quick decision making that will support the fashion marketers and merchandisers in satisfying the customer.

See also **Fashion Industry; Retailing.**

#### BIBLIOGRAPHY

- Harris, Louis. *Merchant Princes*. New York: Harper and Row, 1979.
- Kotler, Philip, and Gary Armstrong. *Principles of Marketing*. 9th ed. Upper Saddle River, N.J.: Prentice Hall, 2001.
- Stone, Elaine. *The Dynamics of Fashion*. New York: Fairchild Publications, 2004.
- Traub, Marvin. *The Bloomingdale's Legend and the Revolution of American Marketing*. New York: Random House, 1993.

Elaine Stone

**FASHION MODELS** In the nineteenth century, the first living mannequins, or “manikins,” took their name from the static dummy or lay figure they were soon to replace as the principal form of display in the dressmaker’s salon. While the word “mannequin”—in French, *le mannequin*—described the woman, the word “model”—*le modèle*—designated the gown she exhibited in the salon. The model gown was a one-off that did not go into production; it was thus both an exclusive dress for sale to an individual client, and a prototype (hence the term model) sold to a fashion buyer for adaptation to the mass market. Both model gowns and model women were at the heart of the commercial development of the French couture industry and its global markets, and there was always some confusion in the terminology. The dual meaning of the word “model” also signals the ambivalent status of the earliest fashion models, hovering uneasily between subject- and object-hood. They invoked both admiration and disapproval, disconcerting their critics precisely be-

cause they wore fashionable dress in public for money rather than for its own sake.

#### Origins

Charles Frederick Worth is generally thought to be the first couturier to use live models. However, many nineteenth-century dressmakers had a young woman available to put on a dress for a client, although their primary mode of display was a wooden or wicker dummy. Indeed, Worth met his future wife, Marie, while she was employed to model shawls to customers on the shop floor of their mutual employer, the mercer Gagelin et Opigez. The couple set up their first *maison de couture* in 1858, and Marie modeled in the Worth salons until the 1870s, after which she remained responsible for training the house mannequins. Maison Worth’s real innovation was thus to institutionalize the profession within the increasingly bureaucratic structure of a couture house, having several trained house mannequins, rather than using the occasional *petit main*, or seamstress, as a model.

#### The Early Twentieth Century

Lady Duff Gordon, trading as Lucile, claimed to have started the first mannequin parades in London in the late 1890s. She trained her mannequins in carriage and deportment and gave them stage names such as Hebe, Gamela, and Dolores. Often six feet tall, they struck dramatic poses during the parades but barely smiled and never spoke. When Lucile opened in New York in 1910 and then Paris in 1911, she took with her four of her London mannequins whose glamour was widely reported in the press of both continents. Dolores later joined the Ziegfeld Follies, and there are many parallels between the fashion model and the chorus girl.

In the same period, fashion magazines began to use photography alongside fashion illustrations, but the women in these photographs were often actresses and, later, society women, rather than professional mannequins, and, with some notable exceptions, the two career paths—photographic and catwalk models—remained separate until well into the 1960s.

Catwalk modeling was always a specialist option. Mannequins were full-time employees of the house and sometimes even lived in. In Paris, both Paquin and Poiret were in the vanguard in showing their fashions on live mannequins, but between 1900 and 1910 most couture houses had their *cabine*, or studio, of mannequins. Although poorly paid and barely respectable, they were also considered exceptionally glamorous. From behind the scenes, they would be summoned several times a day to model gowns for private customers and professional buyers alike, under the direction of the *vendeuse*. Until approximately 1907, they wore a high-necked and long-sleeved black satin sheath, or *fourrure*, beneath the luxury gowns; although generally believed to designate their lack of respectability, the *fourrure* must also have facilitated the rapid costume changes required.

The appearance of three paid mannequins with an unnamed couturier at the Auteil racecourse in 1908 caused outrage, but the practice rapidly became common. In 1910, Poiret made a film of a mannequin parade, and in 1911 he toured Europe with a troupe of uniformed mannequins. In 1913, both he and Paquin undertook mannequin tours of the United States; in one town, the host department store responded to Paquin's mannequins with a matching parade of American male mannequins. Department stores in the United States were, if anything, ahead of Parisian couturiers in pioneering the use of models in dramatic fashion shows. In 1924, Jean Patou traveled to New York to recruit six American mannequins to model in Paris for his American customers whose physique, he claimed, was longer and leaner than that of the "rounded French Venus." Paquin, Poiret, and Patou understood the importance of showing on live models in the marketing of modern fashion. All were able to harness innovative publicity techniques to the early twentieth-century desire to see fashion in motion.

### The Mid-Twentieth Century

John Powers opened the first American model agency in 1923; the Ford modeling agency was founded in 1946. By contrast, the first French model agency opened only in 1959, perhaps because French fashion houses had always employed their own models. In New York in the 1920s, there was also a mannequins' school dedicated to teaching fashion modeling techniques.

By the 1920s, fashion journalists were beginning to report not only on the seasonal fashions, but equally on individual mannequins from the Paris "openings." Captain Molyneux's principal mannequin, Sumurun (Vera Ashby), was well known; in the 1930s, the in-house mannequins of the London department store Selfridges were popular figures, while Schiaparelli's mannequin Lud was reputed to be married to a lion-tamer.

After World War II, the profession of model acquired some respectability, perhaps due to cinematic representations of models in films such as *Cover Girl* (1944), *Funny Face* (1957), and *Blowup* (1966). The social status of models improved as several married into the aristocracy.

Modeling styles changed. From the early twentieth-century the mannequin had been required to move sedately in the salon, notwithstanding the risqué connotations of Lucile's "goddesses" and Poiret's undulating mannequins. By contrast, when, in 1947, Christian Dior showed his "New Look," he encouraged his models to do theatrical turns, knocking over ashtrays in the audience as their coats swung round. However, in general modeling styles remained staid and the 1950s' model was required to look haughty and disdainful. Paris fashion houses maintained a *cabine* of fourteen to eighteen models, and there tended to be a "house style" of modeling, although each model was a different physical type to represent the range of clients' looks. It was therefore, revolutionary when, in the

late 1950s, the British designer Mary Quant first showed on photographic mannequins who danced frenetically to jazz music and then froze in graphic, static poses on the catwalk.

### The 1960s to the Early 2000s

Quant laid the path for the innovations of the 1960s when the development of ready-to-wear required a different kind of presentation. Now models were required to dance, act, and clown on the catwalk. In Courrèges's futurist collection of 1965, grinning models danced in experimental kinetic movement to *musique concrète*. Marie Helvin recalled that haute couture modeling in the 1960s and 1970s was about contact with hand-made, one-off clothes, whereas showstopping modeling techniques, photogenic beauty, and the showgirl instinct were the prerequisites of the ready-to-wear show.

Until then, models had been poorly paid, but their compensation went rocketing up in this period; top models could command \$1,000 for a one-hour show in Milan and even a little more for one in Paris. The strict separation between house mannequins and photographic models began to be eroded and the proliferation of media images of the young, beautiful, and fashionable in the 1960s ensured that photographic models like Jean Shrimpton ("the Shrimp") and Twiggy became iconic figures of their times.

The rise of the supermodel in the early 1990s was followed by a fashion for more waiflike models with slighter frames and quirker looks. Their salaries, however, did not shrink correspondingly. By the end of the twentieth century, models were firmly established as the new celebrities. Feted in gossip columns and highly compensated, they were far removed from their early twentieth-century predecessors with their dubious status and poor pay. Nevertheless, and despite the high visibility of the black model Naomi Campbell, models of color continue to be underrepresented in the industry at the beginning of the twenty-first century.

See also **Mannequins; Patou, Jean; Quant, Mary; Twiggy; Worth, Charles Frederick.**

### BIBLIOGRAPHY

- Ballard, Bettina. *In My Fashion*. London: Secker and Warburg; New York: David McKay Company, 1960.
- Balmain, Pierre. *My Years and Seasons*. Translated by Edward Lanchberry with Gordon Young. London: Cassell, 1964.
- Bertin, Célia. *Paris à la Mode*. Translated by Marjorie Deans. London: V. Gollancz, 1956.
- Castle, Charles. *Model Girl*. Newton Abott, U.K.: David and Charles, 1977.
- De Marly, Diana. *Worth: Father of Haute Couture*. London: Elm Tree Books, 1980.
- Evans, Caroline. "Living Dolls: Mannequins, Models and Modernity." In *The Body Politic*. Edited by Julian Stair, 103–116. London: Crafts Council, 2000.



- . “The Enchanted Spectacle.” *Fashion Theory* 5, no. 3 (2001): 271–310.
- Etherington-Smith, Meredith, and Jeremy Pilcher. *The “It” Girls*. London: Hamish Hamilton, 1986.
- Gordon, Lucy Wallace Duff, Lady. *Discretions and Indiscretions*. London: Jarrolds, 1932.
- Gross, Michael. *Model: The Ugly Business of Beautiful Women*. London and New York: Bantam, 1995.
- Helvin, Marie. *Catwalk*. London: Pavilion Books, 1985.
- Kaplan, Joel H., and Sheila Stowell. *Theatre and Fashion: From Oscar Wilde to the Suffragettes*. Cambridge, U.K.: Cambridge University Press, 1994.
- Keenan, Bridget. *The Women We Wanted to Look Like*. London: Macmillan, 1977.
- Leach, William. *Land of Desire: Merchants, Power, and the Rise of a New American Culture*. New York: Vintage Books, 1994.
- Liaut, Jean-Noël. *Cover Girls and Supermodels 1945–1965*. Translated by Robin Buss. London and New York: Marion Boyars, 1996.
- Poiret, Paul. *My First Fifty Years*. Translated by Stephen Hayden Guest. London: V. Gollancz, 1931.
- Seebohm, Caroline. *The Man Who Was Vogue: The Life and Times of Condé Nast*. London: Weidenfeld and Nicolson, 1982.

Caroline Evans

## FASHION MUSEUMS AND COLLECTIONS

Clothing has been collected and exhibited by a variety of individuals and institutions. Already in the eighteenth century, Madame Tussaud of wax-museum fame, was acquiring and displaying the clothing of celebrities. Today, a wide variety of museums collect dress and textiles, including anthropological and ethnological museums, history museums, art museums, design museums, and specialized fashion and textile museums.

In Paris, still the international capital of fashion, there are two important fashion museums: the Musée de la Mode et du Costume at the Palais Galliera, which was formerly known as the Musée du Costume de la Ville de Paris, at 10 Avenue Piere-1<sup>er</sup>-de-Serbie in the 16<sup>th</sup> arrondissement; and the Musée de la Mode et du Textile at 107 Rue de Rivoli in the 1<sup>st</sup> arrondissement, which is affiliated with the Louvre. The former was founded in the 1920s and is funded by the city of Paris; it has been at its present location in the Galliera since 1977. The latter opened its doors in 1986 and is more lavishly funded by the state. For simplicity’s sake, we might refer to them, respectively, as the Galliera and the Louvre. The Galliera possesses an extensive collection of historical dress, while the Louvre is stronger in contemporary fashion. The Louvre also houses, but does not own, the collections of the Union Française des Arts du Costume. Among the Galliera’s best exhibitions was the late Guillaume Garnier’s *Paris Années Trentes* (1987). Pamela Golbin, one of several curators at the Louvre’s fashion museum, has organized innovative exhibitions, such as *Lumière*.

The fashion designer Yves Saint Laurent is organizing his own museum in Paris. Elsewhere in France, the Textile Museum in Lyons has an important collection, while nearby Romans is home to a small shoe museum.

In London, the most important collection of fashion belongs to The Victoria & Albert Museum, one of the world’s most important museums of the applied arts. As early as 1913, The V&A exhibited eighteenth-century fashions. In the 1970s Cecil Beaton obtained many examples of high fashion for the museum. A permanent exhibition of historic costume, arranged chronologically, has been on display for many years in the costume gallery. In 1994, the V&A mounted an important exhibition, *Streetstyle: From Sidewalk to Catwalk*, curated by Amy de la Haye, which compared subcultural styles such as punk with high fashion. Another curator, Claire Wilcox, has organized *Fashion in Motion*, a monthly event that includes a live fashion show. Wilcox also curated the 2001 exhibition *Radical Fashion*.

In 2002, after years of effort, the fashion and textile designer Zandra Rhodes opened the Museum of Fashion and Textiles in London. Judith Clark’s tiny eponymous gallery has also presented innovative fashion exhibitions. Elsewhere in Great Britain, there are a number of other fashion museums, which were founded by individual collectors. For example, Dr. and Mrs. C. Willett Cunningham created the Gallery of English Costume in Manchester, and Mrs. Doris Langley Moore created the Museum of Costume in Bath. Mrs. Hélène Alexander founded the Fan Museum in Greenwich.

Oddly enough, there exists no full-scale fashion museum in Italy, although the Galleria del Costume in the Palazzo Pitti (Florence) has a significant collection and mounts occasional exhibitions. There are also a number of private collections in Italy, such as that of Enrico Quinto in Rome. Many fashion designers have their own archives, as well.

In the United States, many art museums have important costume collections. The most famous is the Costume Institute of the Metropolitan Museum of Art in New York City. Diana Vreeland, formerly editor-in-chief at *Vogue*, became Special Consultant to the Costume Institute in 1972. She organized more than a dozen exhibitions on themes such as the *The 18th-Century Woman* (1981), *Romantic and Glamorous Hollywood Design* (1974), and *Yves Saint Laurent* (1983). Although subject to criticism on the grounds of commercialism and historical inaccuracy, Mrs. Vreeland’s shows were undeniably glamorous, and they succeeded in abolishing the aura of antiquarianism that had previously surrounded most “costume” exhibitions.

The Museum at the Fashion Institute of Technology is the only museum in New York dedicated primarily to fashion. It owns some 50,000 examples of clothing and accessories, with their greatest strength in modern and contemporary fashion. Richard Martin and Harold

Koda organized a number of important exhibitions at FIT, including *Fashion and Surrealism* (1987), before they moved uptown to the Costume Institute. Martin's premature death in 1999 at the age of 52 robbed the field of a brilliant intelligence. In 1997 Valerie Steele became chief curator of the Museum at FIT. Among her many exhibitions are *The Corset: Fashioning the Body* (2000), *Femme Fatale: Fashion and Visual Culture in Fin-de-Siècle France* (2002), and *London Fashion* (2001), which received the first Richard Martin Award from the Costume Society of America. The Brooklyn Museum of Art also has impressive holdings in fashion and has mounted exhibitions, such as *The Genius of Charles James* (1982). The Museum of the City of New York has another important collection, which focuses on clothing made and/or worn in the metropolis. It is especially strong in fashions of the Gilded Age and in theatrical costumes. Other North American museums with important fashion collections include the Boston Museum of Fine Arts, the Los Angeles Museum of Art, and the Royal Ontario Museum.

The Kyoto Costume Institute is a private museum in Japan founded by the Wacoal Company, which manufactures foundation garments. The chief curator, Akiko Fukai, has organized a number of important exhibitions, including *Japonism Fashion* (1994), which has traveled to museums worldwide. Fashion museums have recently been opened or are planned in many places around the world, including Belgium (the Moda Museum in Antwerp, curated by Linda Loppe), Chile, and Goa.

See also **Belgian Fashion; Cunningham, C. Willett and Phillis; Fashion Education; Japonisme; Moore, Doris Langley; Rhodes, Zandra; Saint Laurent, Yves; Vreeland, Diana.**

#### BIBLIOGRAPHY

- Ribiero, Aileen. "Re-Fashioning Art: Some Visual Approaches to the Study of the History of Dress." *Fashion Theory* 2, no. 4 (December, 1998).
- Steele, Valerie. "A Museum of Fashion Is More than a Clothes-Bag." *Fashion Theory* 2, no. 4 (December, 1998).
- Taylor, Lou. "Doing the Laundry? A Reassessment of Object-Based Dress History." *Fashion Theory* 2, no. 4 (December, 1998).

Valerie Steele

**FASHION ONLINE** Fashion was first propelled onto the Internet (c. 1994) by what María Contreras refers to in *Vogue España* as that old refrain "adapt or die." A decade into Web history, it has become clear the Internet is used for gathering information, communication, and entertainment. Rather than becoming a world, the Web has become an essential tool for living.

Theoretically, if not culturally, fashion is well suited to the new media. As the photographer and showStudio.com founder Nick Knight observes, "speed of change" is the essential nature of fashion and new

media. Both promote image in an era where perception (branding) is as important, if not more so, than the fashion object.

The Web does not threaten print media. Even the founders of the online zine, Itfashion.com, assert that "the existence of paper magazines is necessary." Vanity sites have, however, become an essential part of public relations and brand-building strategy. The primary purpose of a vanity site is to communicate the brand. Unlike a television or commercial, a Web site offers "bidirectional communications" (Deborah Kania) and invites dialogue between the brand and the consumer. Almost all sites have a "Contact Us" or e-mail function built into their architecture. Some sites integrate the feedback function into their content/identity. Thus on emilio-pucci.com users are encouraged to "sign in" on the guest book section where they are asked: "Do you have a Pucci story of your own?" and encouraged to share it, which maximizes the emotional bond that is unique to the brand. On johngalliano.com, users can "Whisper sweet words to John Galliano or confide in Miss Galliano" via the "Love Letters" section.

The vanity site provides the brand a means to create a multisensory experience that creates a bond between the brand and user resulting in "stickiness"—the desire to come back—and encourage consumer loyalty and possibly profitability.

Fashion is a hard sell on the Web, but not an impossible one. What we have learned so far is that e-commerce is more easily adaptable to certain sectors than others. Shopping at the Gap or Banana Republic online, for example, is essentially the same as ordering from the catalog, and these chain stores have the back-end operations already in place to support large-scale e-commerce ventures. Vintage clothing also sells well on the Web, because it provides unique accessibility to one-of-a-kind items (think ebay).

Gradually, shopping on the Web is becoming a desirable form of entertainment, not to mention convenience. (Colette.fr reports that one of their first orders came from a client who "lived but five minutes from the store.") Web demographics—above-average income and education—suggest that this is an area that will continue to be developed.

The most exciting, and potentially, revolutionary impact of the Web on fashion is its inherent democratic nature. Whereas high fashion is built upon exclusivity, the Web offers full-access, twenty-four hours a day, seven days a week: both grandma and Gucci have equal access to the virtual world. In the 1960s the legendary *Vogue* editor Diana Vreeland celebrated "youthquake," ostensibly the end of fashion dictatorship. The ingress of the Web beyond the velvet ropes into the theater of fashion—usually the bailiwick of international press and celebrities—is significant. It suggests that the Web might be the tool that incites a twenty-first-century

shake-up. In a virtual world, a camel can, in fact, pass through the eye of a needle.

See also **Fashion Advertising; Fashion Editors; Fashion Journalism; Fashion Magazines; Fashion Models; Vogue.**

#### BIBLIOGRAPHY

Borrelli, Laird. *Net Mode: Web Fashion Now*. London: Thames and Hudson, Inc., 2002.

Kania, Deborah. *Branding.com: On-line Branding for Marketing Success*. Lincolnwood, Ill.: NTC Contemporary Publishing Company, 2000.

*Laird Borrelli*

**FASHION PHOTOGRAPHY** A fashion photograph is, simply, a photograph made specifically to show (or, in some cases, to allude to) clothing or accessories, usually with the intent of documenting or selling the fashion. Photographs of fashionable dress, in existence since the invention of photography in 1839, are not fashion photography. The distinguishing feature—and the common denominator in the enormous diversity of style, approach, and content—is the fashion photograph’s intent to convey fashion or a “fashionable” lifestyle. At the end of the twentieth century, the Calvin Klein advertisement featuring only Calvin’s portrait changed the very definition of a fashion photograph from a picture of the featured clothing to the selling of a glamorous lifestyle identified with a specific logo.

Fashion photography has sometimes been called ephemeral, commercial, and frivolous, and its importance has been called into question. That fashion photography has a commercial intent implies to some that it lacks photographic and artistic integrity. In reality, it has produced some of the most creative, interesting, and socially revealing documents and revealed the attitudes, conventions, aspirations, and taste of the time. It also reflects women’s image of themselves, including their dreams and desires, self-image, values, sexuality, and interests.

The psychology behind a fashion photograph as a selling device is the viewer’s willingness to believe in it. No matter how artificial the setting, a fashion photograph must persuade individuals that if they wear these clothes, use this product, or accessorize in such a way, the reality of the photograph will be theirs. The fashion photograph can offer a vision of a certain lifestyle (from glamorous to grunge), sex, or social acceptance (via the most current, the most expensive, or the most highly unattainable), but it is the viewer’s buy-in that makes the photograph successful.

#### Early Fashion Photography

The earliest fashion photographs were made, probably in the 1850s and 1860s, to document fashion for Parisian fashion houses. Reproduction in fashion journals oc-

curred much later, between 1881 (with the invention of the halftone printing process by Frederic Eugene Ives) and 1886 (when the refinement of the process made it financially practicable). This breakthrough made it possible to reproduce photographs and sell to a large audience through the medium of the printed page.

In the late nineteenth and early twentieth centuries, distinctions between fashion photography, portraiture, and theater photography were often blurred. The idea of using professional models was initially considered shocking, and it thus became fashionable in the early years of the century for society celebrities, such as Gertrude Vanderbilt Whitney, to model. The result was that fashion photographs were strikingly similar to society portraits. The idea of using an actress such as Sarah Bernhardt is not unlike the vogue in the early 2000s for using Gwyneth Paltrow or Madonna or the tennis stars Venus and Serena Williams to model current fashion.

That nineteenth-century fashion photography did not exist is a misconception. Many believe that Americans were first in this field, perhaps based on Edward Steichen’s claim that he was the first fashion photographer. This has obscured the contributions of such important Parisian fashion photographers as Maison Reutlinger, Talbot, Felix, Henri Manuel, and Boissonnas et Taponnier as early as 1881. They worked in the studio, but charming outdoor fashion photography was also shot on the Parisian boulevards and at the races by the Seeberger Frères in the first decade of the twentieth century.

#### American Fashion Photography, 1900–1930

The first important American photographer of fashion was European-born Baron Adolf de Meyer, who had entered fashionable London society through his marriage to Donna Olga Alberta Caracciolo (the daughter of the duchess of Castelluccio and reputed to be the illegitimate daughter of King Edward VII) and was knighted by the king of Saxony. De Meyer changed fashion photography by disintegrating form and bathing his pictures in a limpid atmosphere and shimmering light, creating what *Vogue* in 1914 termed “artistic” photography. This approach changed the idea of what a fashion photograph should be, from an exacting depiction of a garment’s detail to an evocation of mood.

In 1924, Edward Steichen replaced the soft-focus effects of de Meyer’s style with the clean geometric lines of photographic modernism. Steichen rejected the rococo backdrops used by de Meyer in favor of unadorned, sleek settings and showed modern woman in the sports clothes that reflected a new, liberated sense of herself and her freedom from the corset. Many of Steichen’s most important photographs featured his signature model Marion Morehouse, who epitomized the look of the “contemporary” woman, the flapper. Other important photographers who benefited from and were influenced by Steichen’s innovations were George Hoyningen-





**Photograph of model at Lincoln Memorial.** The true fashion photograph is not one that simply records a clothing design, but one that conveys a desirable lifestyle suggested by that design. PHOTOGRAPH BY TONY TINSELL. THE LIBRARY OF CONGRESS. REPRODUCED BY PERMISSION.

Huene, known for his extraordinary use of negative space and passion for the Greek ideal, and his student Horst P. Horst, who used theatrical lighting and trompe l'oeil effects to great advantage.

#### **Realism and Surrealism**

Another startling change—and one that would have profound impact on future fashion photography—was the

1933 introduction of out-of-door realism by the Hungarian sports photographer Martin Munkacsi. Munkacsi's *Harper's Bazaar* photograph of the model Lucile Brokaw running down the beach—blurred, in motion, and possessing the naturalness of amateur snapshots—changed the course of fashion photography. The spontaneity was revolutionary, particularly when contrasted to Steichen's posed and static style that preceded it. Realistic fashion

photography offered the modern woman a vision that she could apply to her own life. Munkacsí's snapshotlike realism influenced a long line of photographers, including Toni Frissell, Herman Landshoff, and Richard Avedon.

The artistic ferment of Paris in the 1930s, particularly the fantastic, mysterious, and dreamlike aspects of surrealism, had a profound influence on fashion photography. The painter and photographer Man Ray produced fashion photography as a way of earning money that enabled him to pursue "serious" painting and experimental photography. He was able to chart a new direction for fashion photography because he disregarded the conventions of fashion depiction, instead producing elongations, double exposures, and a "fashion rayograph" that simulated what a fashion would look like when radioed from Paris to New York. Other fashion photographers who incorporated surrealist-influenced ideas in their work were Peter Rose-Pulham, André Durst, George Platt Lynes, and Cecil Beaton.

Constant experimentation and technical virtuosity marks the fashion work of Erwin Blumenfeld, who used solarization, overprinting, combinations of negative and positive images, sandwiching of color transparencies, and even drying the wet negatives in the refrigerator, resulting in crystallization, to achieve his extraordinary effects. Also important in the 1930s was the appearance of Kodachrome, which arrived on the market in 1935. Louise Dahl-Wolfe was one of the first and most important practitioners of color in fashion photography, creating striking photographs of American fashion with the new color technology.

### Fashion Photography after World War II

Fashion photography was severely affected at the outbreak of World War II in 1939, not only because of the lack of materials, models, and safe locations, but also because of a demoralization in attitude toward the medium: because fashion was seen as a frivolous and unnecessary form of luxury, fashion magazines stressed women's role in the war, rationalized fashion as morale building, published war reports instead of society columns, and featured the tailored, plain, and often drab clothing more suitable for a world subjected to daily reports of death and destruction. Studio photography with its complicated props and setups was almost eliminated. In general, photographers such as Lee Miller in Paris and Cecil Beaton in London turned to a straightforward documentary approach. Louise Dahl-Wolfe produced some of the most important American fashion photography of the 1940s using a clear, straightforward style.

With the end of the war, New York replaced Paris as the mecca of fashion photography. America's fashion design and ready-to-wear industry achieved its first international success in the postwar period. The time was thus ripe for the emergence of two young American talents who would dominate fashion photography for many years to come: Richard Avedon and Irving Penn.

The charming ease of Richard Avedon's fashion style of the 1950s was perfectly suited to a war-weary society. In this decade, Avedon staged his models as glamorous but "real" girls whose carefree exuberance was both sophisticated and appealing. Each was an actress of sorts, creating both a fashion look and a dialogue of emotions. By the 1960s, Avedon's fashion work had moved from the outdoor locations and softly beautiful natural light of this early work to his signature style of models running and jumping across a plain white background, illuminated with the harsh, raking light of the strobe.

The other major fashion leader whose work started in the 1940s is Irving Penn. Penn's work has no rival in terms of formal complexity, in the rich beauty of constructed shape, elegance of silhouette, and abstract interplay of line and volume. Compared with the white-hot moment of immediacy of Avedon's photographs, Penn's work aimed at the values of monumentality, formal clarity, and quiet truth. Perhaps his most extraordinary shots are those done in collaboration with his wife, the model Lisa Fonssagrives-Penn.

Both Avedon and Penn have each sustained careers over a period of five decades, a record of remarkable range and consistency. Avedon's ability to take inventive risks and his creative inspiration, with its kaleidoscope of techniques and ideas, are unequalled in the field of fashion photography. He always captures the "look" of the moment, in part because of his choice of the model who best epitomizes the time, from Dorian Leigh, Dovima, and Suzy Parker to Verushka, Twiggy, Jean Shrimpton, Brooke Shields, and Nastassja Kinski.

### Fashion Photography in the 1960s

Fashion photography in the 1960s yielded to more socially oriented and exotic themes. In part this was due to the fact that fashion design began to show the influence of many diverse sources, from peasant and "street" styles to the women's liberation movement, the space program, and pop art. There was a break with convention, both in social mores and fashion itself: outrageous, seemingly unwearable outfits were designed, models reflected a new diversity of "look" and race, and fashion was redefined toward a defiant market dominated by the youth culture.

The 1960s was also a time when certain fashion photographers, including Bert Stern and David Bailey, enjoyed high-voltage lifestyles, skyrocketing fees, and lavish studio setups. At the opposite extreme, the influence of Penn and Avedon continued to attract serious young photographers from the world over to New York. Yasuhiro Wakabayashi, known professionally as Hiro, developed a monumental, clear, and memorably vivid style while Bob Richardson's work flirted with social concerns such as lesbianism. Other photographers working in the field of fashion in the 1960s included William Klein, Art Kane, and Diane Arbus, whose photography for the *New York Times Magazine* was among the most disturbing and uncharacteristic children's fashion images ever published.

### Fashion Photography in the 1970s

In the 1970s, the tide again turned: Diana Vreeland resigned from her influential reign as editor-in-chief of *Vogue*, and in January 1977, American *Vogue* reduced the actual trim size of the publication. Meanwhile, French *Vogue* took the creative lead in fashion photography in this decade and offered their two leading photographers, Helmut Newton and Guy Bourdin, complete creative autonomy. Deborah Turbeville produced work that reflected psychological dislocation in the modern world, in part through her slouching and stylized poses. She was the first to use overweight and “ugly” models, pioneering a more diverse standard of model. Her “bathhouse” photographs published in *Vogue* (May 1975) created a furor by evoking the grisly aura of a concentration camp or the frightening vacuousness of drugged stupor.

### Fashion Photography in the 1980s

Some of the most important editorial and advertising fashion photography of the 1980s continued to be done by Richard Avedon. His brilliant advertising campaign “The Diors,” a story spun weekly in the pages of the *New York Times Magazine*, created the enduring vogue for narrative in fashion photography. Avedon’s shot of Nastassja Kinski, her nude form sensuously entwined with a gigantic snake, has become a classic. Women’s strength and independence was emphasized, from sporty and athletic to domineering and brutalizing. Numerous photographers, including Denis Piel, Bruce Weber, and Bert Stern pictured women threatening men with everything from pocketbooks to knives and chains. Fashion itself, particularly in the work of such designers as Jean Paul Gaultier, Azzedine Alaïa, and Issey Miyake (whose work was notably photographed by Penn), helped form the look of the decade’s photography

### Fashion Photography in the 1990s

In the last decade of the century, Herb Ritts, Steven Meisel, and Bruce Weber continued to produce some of the most interesting and innovative work, including Weber’s hilarious hip-hop version of a black Snow White and the Seven Dwarfs and his seminal spread dealing with the impact of grunge on fashion in the 1990s (including the first post-punk nose ring in a *Vogue* fashion spread). Two of the greats of fashion photography, Irving Penn and Helmut Newton, continued to dominate the field. Ellen von Unwerth’s romantic individualism and Sheila Metzner’s spare but sumptuous style were also widely evident. Models were increasingly racially diverse, with a number of black models, such as Iman, Naomi Campbell, and Karen Alexander, achieving the status of celebrity superstars. As to the early years of the twenty-first century, one must await the knowledge of hindsight to assess the importance of very recent fashion photography as well as the development of such young talents as Christophe Kutner, Glen Luchford, Javier Vallhonrat, and Craig McDean. What seems certain is that fashion

photography—whether published in *Vogue*, *W*, *Dazed and Confused*, or *Sleaze Nation*—will continue to reflect the society and the times in which it was made.

See also **Actors and Actresses, Impact on Fashion; Art and Fashion; Avedon, Richard; Beaton, Cecil; Hartnell, Norman; Hoyningen-Heune, George; Newton, Helmut.**

#### BIBLIOGRAPHY

- Brooke-Adler, Isabel. “Baron von Meyer.” *Art Journal* (1899): 270–272.
- Chase, Edna Woolman, and Ilka Chase. *Always in Vogue*. Garden City, N.Y.: Doubleday and Company, 1954.
- Edwards, Owen. “Blow-Out: The Decline and Fall of the Fashion Photographer.” *New York* 6, no. 22 (28 May 1973): 49–56.
- Ewing, William A., and Nancy Hall-Duncan. *Horst*. New York: International Center of Photography, 1984.
- Frenzel, H. K. *Hoyningen-Huené: Meisterbildenisse*. Berlin: Verlag Dietrich Reineer, 1932.
- Garner, Philippe, and David Alan Mellor. *Cecil Beaton, 1920–1970*. New York: Stuart, Tabori and Chang, 1995.
- Goldberg, Vicki, and Nan Richardson. *Louise Dahl-Wolfe*. Foreword by Dorothy Twining Globus. New York: Harry N. Abrams, 2000.
- Hall-Duncan, Nancy. *The History of Fashion Photography*. New York: Alpine Press, 1978.
- Harrison, Martin. *Appearance: Fashion Photography since 1945*. New York: Rizzoli International, 1991.
- Hayden-Guest, Anthony. “The Return of Guy Bourdin.” *New Yorker* 70, no. 36 (7 November 1994): 13–46.
- Kramer, Hilton. “The Dubious Art of Fashion Photography.” *New York Times*, 28 December 1975.
- Lehmann, Ulrich. *ChicClicks: Creativity and Commerce in Contemporary Fashion Photography*. Boston: The Institute of Contemporary Art in collaboration with Hatje Cantz Publishers, 2002.
- Liberman, Alexander. *The Art and Technique of Color Photography: A Treasury of Color Photographs by the Staff Photographers of Vogue, House and Garden, and Glamour*. New York: Simon and Schuster, 1951.
- Ray, Man. *Self-Portrait: Man Ray*. London: Andre Deutsch, 1963.
- Sargeant, Winthrop. “Profiles: Richard Avedon.” *New Yorker* 34 (8 November 1958): 49–50.
- Steichen, Edward. *A Life in Photography*. New York: Doubleday and Company, 1963.
- Thornton, Gene. “Turbeville Gives Fashion a Torture Treatment.” *New York Times*, 24 January 1977.

Nancy Hall-Duncan

**FASHION PLATES** Fashion plates are small printed images, often hand-colored, of people wearing the latest fashions and depicted in conventional minimally narrative social contexts. They flourished from the late eighteenth to the early twentieth centuries, and were usually



distributed with fashion magazines either as integral parts of the editorial content or as supplementary plates. The poet Charles Beaudelaire, in his essay *The Painter of Modern Life*, described fashion plates as an image of the “ideal self” and thus a reflection of the artistic, historical, moral, and aesthetic feeling of their time. He wrote in 1863, when fashion plates were reaching a peak in their development. Although the basic purpose of the fashion plate was to illustrate new styles and sell more clothes, their charm gives them an established place among the minor graphic arts. Sadly for the student, fashion plates are often removed from the magazines in which they appeared and sold as collectors’ pieces; divorced from their original context they lose much value as historic sources.

### Origins

People attractively or unusually dressed have been popular graphic subjects at least since the sixteenth century, when the *Costume Book* or *Trachtenbuch* brought them into popular publishing. By the middle of the seventeenth century, the graphic artist Vaclav Hollar had given such illustrations new artistic status and Bosse, Callot, and de Hooghe began to group their fashionables in suitable settings.

Not until the last quarter of the seventeenth century did the series of popular prints (usually termed *Les Modes*) of fashions and fashionable people appear. Published by the Paris print sellers, the Bonnarts, with plates by Saint Aubin, Bérain, and Arnoult, they promoted French taste to a wide international market. Nevertheless, such illustrations did not take on a commercial role as advertisements until Jean Donneau de Vizé introduced them into the *Mercure Extraordinaire* and the *Mercure Galant* of 1678 and 1681, noting suppliers as well as garments.

### The Eighteenth Century

Thereafter the fashion plate fell into disuse until the 1750s, reappearing in ladies pocketbooks, diaries, almanacs, and magazines. Occasionally credited to dressmakers, they were popular as fashion guides. The small monochrome plates were often by well-known artists and engravers.

By the last quarter of the eighteenth century, the ending of French Guild restrictions in 1777 made fashionable clothing available to many more consumers, and so opened the market to a flood of illustrated fashion material. The best known, an anthology of some 200 to 400 colored fashion plates compiled from several sources by the publishers Esnaut and Rapilly between 1778 and 1787, is the *Galerie des Modes et Costumes Français*, illustrated most notably by Watteau le Jeune and Desrais. The fine *Suite d’Estampes pour servir à l’Histoire des Mœurs et du Costume* (1778), drawn by J. M. Moreau, had as its stated aim the promotion of French taste. Though often regarded as the quintessence of French fashion, it is more a complete guide to the world of fashionable people in their material context.

### The Nineteenth Century

The publishing boom of the late eighteenth and early nineteenth centuries stimulated the flow of fashion illustrations. Despite the Revolution and the Napoleonic wars, French plates continued to dominate the market, though equally fine examples were produced in England and Germany. Le Brun Tossa in the *Le Cabinet des Modes*, 1785–1789, and La Mésangère in *Le Journal des Dames et des Modes*, 1797–1839, featured high-quality plates by excellent artists, as did John Bell in the English *La Belle Assemblée* 1806–1832, but Bell’s illustrations were often pirated and adapted to local taste.

La Mésangère extended the range of his artist illustrators by publishing them in a series of fashion and genre prints, such as Debucourt’s *Modes et Manières du Jour*, 1810, and the Vernets’ *Incroyables et Merveilleuses* and *Le Bon Genre*, 1818. They are a precedent for the more intimate picture series by Gavarni and Deveria, whose fashion plates were such a feature of the periodicals of the 1830s and 1840s. A successful formula, it was followed by the *pochoir* fashion illustrators of the twentieth century, most notably George Barbier.

The most prestigious early nineteenth-century British contribution to the art of the fashion plate was *Heideloff’s Gallery of Fashion*, 30 aquatint plates, 1797–1801, published by subscription to an aristocratic clientele. Focused on fashions worn by anonymous noble ladies, it also included the creations of named dressmakers. With the aquatint plates of British popular venues crowded with fashionable men, women, and children, published by London tailor Benjamin Read between the 1820s and 1840s, the fashion plate was decisively democratized. Prints and full-scale patterns were sold through Read’s establishments in London and New York, where American versions soon appeared.

By the mid-nineteenth century, with the expansion of popular and pictorial publishing as well as the clothing trade, the fashion plate proliferated. To satisfy demand, engraving establishments, especially in Britain and Germany, provided type images easily grouped and amended for the cheaper fashion and advertising market. The male fashion figure largely disappeared from fashion plates at this time; however arranged and accessorized, he lacked the vivacity of fashionable men as drawn by Paul Gavarni and the Vernets.

Quality fashion plates remained available through large-scale French publishers and agents for publications abroad, such as Goubaud and Mariton. The best documented and most prolific artists during the middle of the nineteenth century were the Colin sisters—Heloise Leloir, Anais Toudouze, and Laure Noel—who, together with their rival Jules David, were skillful in showing the requisite dress detail in conventional evocative settings. American fashion plates, sometimes modified from French originals, as in *Godey’s Ladies’ Book* and the publications of Mme Demorest, could be more practical, even featuring domestic appliances.

### The Artist and the Photographer

By the end of the century, the earlier romanticizing tradition was challenged by avant-garde black-and-white work, dramatic rather than representational. An idealized realism also became fashionable, and A. Sandoz, especially for the House of Worth, produced Tissot-like groupings set in the wider world of the modern woman of the twentieth century.

His source material probably included photographs from the house archives, but although promotional photographs had been occasionally used in fashion publications since the 1860s, and press pictures of fashionable scenes, such as those by the Seeberger brothers, were popular, the detailed color reproduction expected by the quality market was expensive. Retouching was easy but the photographs from *Les Modes*, their speciality, illustrate the problems. Idealization, the core of fashion illustration, was problematic, and fashion artists were available, adaptable, quicker, and cheaper.

Confronted by advances in printing and photographic technology and the easy availability of the conventional graphic image, in the early twentieth century the artistic avant-garde retreated to the craft technique of *pochoir* (stencil) printing and hand coloring, producing formal, modernist, *faux naïves* fashion plates in exotic or romantic settings reminiscent of the early nineteenth century. The genre was pioneered by Paul Iribe for Poiret's 1909 collection in *Les Robes de Paul Poiret*, 1909, and by Georges LePape in *Les Choses de Paul Poiret*, 1911. Their work and others of the group, such as Charles Martin and George Barbier, was brought to a wider public by the publisher Lucien Vogel, who launched the elitist *Gazette du Bon Ton* in 1911, the precursor of several similar art and fashion magazines. The general public became aware of the style and technique through prestige advertising, such as *Art Gout Beauté*, 1920–1936, published by the textile firm Albert Godde Bedin.

In general the advertising agencies were very open to modern trends. Not without reference to the cinema, by the early 1930s they had revived the male fashion image illustrating active realistic men in glamorized everyday settings. *Esquire* adopted this style in 1933 and subsequent men's fashion advertisements and magazines would continue it well into the 1960s.

By 1923, the *Gazette du Bon Ton* and its artists had been taken over by *Vogue*. Fashion narrative illustrations were not part of *Vogue's* format, and the work of the *Bon Ton* artists, like that of established *Vogue* artists such as Helen Dryden and Douglas Sutherland, was confined to the elegantly decorative covers. By the late 1920s and 1930s, a new generation of fashion artist, Eric (Carl Erickson), H. Bouet Willaumez, Bouché, and Christian Bérard had begun to convey the essence of style, scene, and above all movement, in vivid and impressionist plates, though occasionally their lack of detail was deplored.

It is the ability to convey the soul of the garment as well as the seams, the ambience and the dynamic of fashion, and the essence of its modernity, which keeps the fashion plate an element of publishing in the early twenty-first century.

See also **Fashion Illustrators; Vogue.**

### BIBLIOGRAPHY

- Cornu, Paul, ed. and preface. *Galleries des Modes et Costumes Français, dessinés d'après nature, 1778–1787*. New, collected edition. Paris: E. Lévy, 1911–1914.
- Gaudriault, Raymond. *La Gravure de Mode Feminine de France*. Paris: les éditions de l'amateur, 1988.
- Ginsburg, Madeleine. *An Introduction to Fashion Illustration*. London: V & A/Compton/Pitman, 1980.
- Hay, Susan. "Paris to Providence: French Couture and the Tirocci Shop." In *From Paris to Providence*. Edited by Susan Hay. Providence: Museum of Art, Rhode Island School of Design, 2000. An admirable study that illustrates the practical use of fashion illustrations.
- Packer, William. *Fashion Drawing in Vogue*. New York: Coward McCann, 1983.
- Steele, Valerie. *Paris Fashion: A Cultural History*. Oxford: Berg, 1998.

Madeleine Ginsberg

**FASHION SHOWS** The fashion show has evolved from an exclusive in-house presentation of haute couture held for a private clientele, to a biannual spectacle of both couture and ready-to-wear clothing that is seen by a vast cross-section of consumers, the mass media, and the fashion industry. A number of cultural and social forces are responsible for this evolution, including the increased consumer awareness of Parisian couture, the rise of the ready-to-wear industry after World War II, the growth of the modeling profession, and the increasing attention paid to the runway by the popular press. While the fashion show today is different from its early-twentieth-century incarnation, it does retain links to its origins in theatrical display and the couture salon shows of that period.

### Origins

In nineteenth-century Paris, it was common practice for dressmaker houses to use their assistants or saleswomen (*desmoiselles du magasin*) to wear the designer's creations while working at the shop. To reach a broader clientele, many couturiers extended this display to the public arena as well, with figures such as Charles Frederick Worth dressing his wife in the latest styles to promenade in socially important areas of the city such as the Bois du Boulogne. In the late nineteenth and early twentieth centuries in London and Paris, the custom-dressmaking trade also maintained important and effective links to the world of theater and advertised its wares by dressing famous actresses both on and off the stage. The couture



**Model backstage at a fashion show.** Since their inception in the early 1900s, fashion shows have evolved from relatively simple in-house events to highly publicized worldwide spectacles. © LANGEVIN JACQUES/CORBIS SYGMA. REPRODUCED BY PERMISSION.

houses of Doucet and Paquin, for example, were very successful promoters through this medium and their clientele included such popular stars as Sarah Bernhardt, Réjane, and Cecile Sorel. The theater, particularly in France and England, became a place to see the most avant-garde styles and eventually a “fashion play” genre developed that revolved around the presentation of the latest couture creations. Dressing members of the fashionable demimonde and house mannequins (the term for models in this period) for the races, opera, and theater premieres, and resort areas were another means of advertising up-to-the-minute designs.

In the first decade of the century, social display was supplemented by organized shows at a fixed time in the couture house. Although a number of designers and fashion personalities claim responsibility for the first fashion show, it was not one person who started the trend, but rather a gradual evolution toward more formal presentations of seasonal clothing lines. By the mid-1910s many designers, including Paul Poiret, Lucile, and Paquin, were using the fashion show as a promotional vehicle. In 1910 Lucile promoted the opening of her New York branch with a spectacular fashion show in a city theater. The presentation had an Arabian Nights theme inspired

by vaudeville revues. Lucile was one of the first to promote her mannequins as public personalities, giving them exotic names such as Dinarzade and Sumurun, and training them to walk with a distinctive gait.

For Paris haute couture, the shows were first presented in Paris or London and then sometimes traveled to America on well-publicized tours. Paul Poiret followed this pattern, organizing a tour in 1911 in which he and his mannequins showed his exotic creations in venues such as charity bazaars, theaters, and department stores throughout Europe. In 1913 he also conducted a heavily promoted tour of the United States with his mannequins, and other designers followed suit, including Jeanne Paquin in 1914 and Jean Patou in 1924. Another innovative mode of presentation in the 1910s was the organization of a *thé dansant*, a popular pastime that showcased new dances such as the tango and the fox-trot. Designers including Lucile and Paquin showed their new designs in such a context, often using theaters as a show venue.

In America, department stores, such as Wanamakers in Philadelphia, started holding regular fashion shows in 1910 and gradually broadened the audience for such fashion display. The advent of the fashion newsreel in the same period also served to bring the fashion show to a



wider clothes-buying public. Beginning in 1910, a number of French, English, and American film companies began to show fashion reels as part of their weekly newsreel production. In 1913 a New York-based film company started documenting the biannual fashion shows in New York that now took place in February for the spring-summer collections and July for fall-winter collections. At this point, modeling was not an evolved routine and both film and fashion magazines often used actresses, opera singers, and dancers as mannequins.

In the United States during World War I, a number of fashion shows were organized to benefit the war effort and toured across the country. In 1914, a Fashion Fête was organized by Edna Woolman Chase, the editor of *Vogue*, to showcase New York designers. Also in that year a number of couture houses banded together to form Le Syndicat de defense de la grand couture française with Paul Poiret as president. In an effort to fight design piracy, the organization charged a standard copyright fee for business customers who wished to reproduce couture designs. The syndicate also placed more stringent rules on who could attend the couture shows and wholesalers and retailers were barred from couture showings unless they were invited.

By 1918 the couture industry had fixed dates for two major shows per year for the foreign buyers that were coming to Paris. The shows were becoming organized presentations using in-house mannequins and by the 1920s, the House of Patou, for example, was employing 32 mannequins to model 450 dresses at each showing. Other contemporary references document between 7 and 15 mannequins regularly employed in the couture houses at this time. One 1920s commentator wrote that the mannequins were still considered “demimondaine” but they did have paid salaries, bonuses, and some had season contracts. In 1923 John Robert Powers established the first modeling agency in New York, which served to professionalize the industry and positioned modeling as a more socially acceptable career. In the 1920s designers also had a set routine and started by showing sports and day clothes, then evening wear.

In the 1930s Elsa Schiaparelli was the first to create themed collections, including “Circus,” “Commedia dell’Arte,” and “Astrology,” among others. These themes added a theatrical flair to her shows between 1936 and 1939 by incorporating music, special lighting, and dance into the presentation. Her 1938 “Circus” collection, for example, included circus performers who jumped, skipped, and flipped all over the couture house.

### The Postwar Era

An increasingly formal presentation style marked the postwar era and at this point the show evolved into the essential organization that is still associated with it in the early 2000s. The show took place in the couture salon, the crowded audience consisted of invited buyers with

important journalists at the front, and there was a specific sequence for the type of dress shown (for example, the wedding dress at the end). Fashion shows often lasted seventy-five minutes and approximately sixty ensembles were presented on between eight and ten models. This period also witnessed the association of particular mannequins with specific couture houses. Mannequins, such as Bettina at Jacques Fath or Praline at Pierre Balmain, with their distinctive saunters, visually represented the designer’s philosophy and often acted as the designer’s muse. While Paris had successfully reestablished itself as the style leader in the postwar era, countries such as the United States, England, and Italy also held regular fashion shows.

It was still common practice to hold fashion shows in department stores and hotels and the *Vogue* editor Edna Woolman Chase recorded in her 1954 memoirs:

Now that fashion shows have become a way of life, now that a lady is hard put to it to lunch, or sip a cocktail, in any smart hotel or store from New York to Dallas to San Francisco without having lissome young things in the most recent models, swaying down a runway six inches above her nose—it is difficult to visualize that dark age when fashion shows did not exist. (Chase and Chase 1954, p. 119)

By the mid-1950s, fashion shows were common in urban centers in semiannual department store displays and, at the local level, they were often incorporated into charity events.

### Ready-to-Wear Market

In the late 1950s the rise of the ready-to-wear market had a significant impact on the organization, number, and scale of fashion shows. In 1959 Pierre Cardin showed his ready-to-wear collection in the *Printemps* department store in Paris and by the mid-1960s, ready-to-wear was regularly included in the fashion calendar. The growth of the ready-to-wear market was also related to the decline in interest in haute couture by the younger generation, who did not want to follow the fashion dictates of Paris. New designers responded to this cultural phenomenon by adding a youthful energy to their fashion shows. The English designer Mary Quant, for example, presented her mod ready-to-wear designs to jazz music and her mannequins skipped and danced down the runway. Quant opted to use print models rather than runway models because she liked the way they moved and the fast pace allowed her to show forty garments in fourteen minutes. The distinction between the runway and photography model was on the wane.

This growth of the ready-to-wear market eventually changed the function of the haute couture fashion show, shifting its targeted audience from private clientele to one consisting mainly of press and buyers. The 1960s also mark the beginnings of the use of the fashion show as a marketing tool to promote the licensed products associated with the house.

### Fashion Show as Spectacle

In the 1970s and 1980s the public visibility and magnitude of fashion shows increased dramatically. In 1973 the designer Kenzo presented a large-scale ready-to-wear show on a stage rather than a runway, indicating a break with haute couture tradition and the increasing emphasis on spectacle. In the 1980s Thierry Mugler and Claude Montana staged theatrical events that further removed the fashion show from the couture salon. Mugler hired a rock impresario to stage his fashion show, an audience of six thousand people attended, and half of the show's tickets were available for purchase by the public. This was the first time that the public was allowed to attend a couture show and marks a trend toward the fashion show as mass entertainment. In the mid-1980s the regular broadcasting of the ready-to-wear shows on cable television further broadened the viewing public. The increased public awareness of the catwalk shows led to the promotion of "supermodels" in the early 1990s. By this time, modeling had long been a socially acceptable profession and the increasing cult of personality in various cultural arenas served to promote models as celebrities on a par with movie actors.

While the majority of fashion designers hold traditional runway shows during the fashion weeks in Paris, London, New York, and other cities, many now have specific themes, mood music, and special lighting and other effects. In the 1990s there were a number of designers, including John Galliano and Alexander McQueen, who became renowned for producing extravagant shows in unusual spaces with narratives and fictional characters. These theatrical stagings have pushed the fashion show beyond the garment and into the realm of the conceptual fantasy. These types of shows function primarily to promote brand recognition and to sell the ready-to-wear lines and the licensed products.

See also **Department Store; Fashion Designer; Fashion Models.**

#### BIBLIOGRAPHY

- Bertin, Célia. *Paris à la Mode: A Voyage of Discovery*. Translated by Marjorie Deans. London: Victor Gollancz Ltd., 1956.
- Castle, Charles. *Model Girl*. Newton Abbott, U.K.: David and Charles, 1977.
- Chase, Edna Woolman, and Ilka Chase. *Always in Vogue*. New York: Doubleday, 1954.
- Evans, Caroline. "The Enchanted Spectacle." *Fashion Theory* 5, no. 3 (September 2001): 270–310.

Michelle Tolini Finamore

**FASHION TELEVISION** Fashion television has revolutionized the dissemination of fashion information to a mass audience; it has become a major marketing vehicle, helping to launch fashion trends and enhance the cult of personality surrounding fashion designers and models. With immediacy that only television can offer,

following fashion has become a source of entertainment for millions. The evolution of fashion television into a distinct genre of broadcasting parallels, but is not limited to, the development of cable and satellite television.

Cable television was developed as a localized service in Pennsylvania in the late 1940s in response to a growing need for improved television reception and better access to existing channels in more remote geographical regions. Since then, it has expanded into a competitive, multibillion-dollar industry; pay television and the launch of satellite broadcasting, first used by the Home Box Office (HBO) network in the early 1970s, contributed to its rapid growth and popularity. Satellite broadcasting, which receives signals from space, transformed cable programming into a global, cost-efficient transmission system, and led to the creation of specialized cable networks that provide viewers with 24-hour news, weather, music, movie, sports, shopping, and entertainment channels.

The 1970s and 1980s saw a boom for cable and satellite broadcasting. It was during this time that fashion television emerged as a genre of broadcasting, with certain networks and television personalities becoming key players in its development. In 1976, Videofashion News, a video version of a fashion magazine, was created and has been produced continuously since, carried by a number of distributors internationally. The series provides viewers with a front-row seat and backstage pass to runway shows around the world, profiling designers, models, and celebrities and reporting on the latest trends.

Elsa Klensch, the preeminent television fashion journalist, got her start in 1980 on the newly created Cable News Network (CNN). Her daily segments and half-hour weekend program, *Style with Elsa Klensch*, which have been broadcast worldwide to millions of viewers, were the first regularly scheduled fashion reports on network television in the United States. *Style*, which continually ranked as one of CNN's highest-watched weekend shows, has covered designer collections from around the world, profiling both designers and models, and the latest trends in interior design.

Klensch's straightforward, comprehensive reporting on international fashion and design has earned the respect of those within the fashion industry as well as the viewing public. She has won numerous awards, including an honor in 1987 from the Council of Fashion Designers of America for bringing fashion to a mass audience; authored the 1992 fashion how-to book, *Style with Elsa Klensch: Developing the Real You*; and made a cameo in Robert Altman's 1994 fashion film *Prêt-à-Porter*. In 2001 and 2002, Klensch collaborated with Videofashion News to produce the hour-long segments, *Trio World Fashion Tour*, for the popular arts channel Trio, which featured top designer collections from the runways of the world's fashion capitals.

Another key personality in fashion television has been the Canadian journalist Jeanne Beker, who launched

Fashion Television (FT) on Video Hits One (VH1) in 1985, now a leading style program. Beker began her career as a music industry journalist in the late 1970s, which informed her approach to reporting on the fashion world. She considers herself an entertainment, not a fashion, reporter. FT started as an intermittent series of one-hour specials and grew into a full series of thirty-nine, half-hour shows a year, broadcast in over one hundred nations with numerous satellite providers, and has since become its own 24-hour network. FT has covered the latest runway collections from around the world, profiled designers and models, offered viewers a peek into post-fashion show parties, and presented FT through the eyes of a psychologist and a rabbi.

According to Beker, fashion executives in the 1980s wanted to add video to fashion coverage with the hope that it could do for fashion what Music Television (MTV) did for music. MTV, which premiered in 1981 as a 24-hour music video channel targeting young adults, has been a launching pad for celebrities and fashion trends. “Madonna wannabes” emerged after her appearance on MTV in 1984; retailers sold Madonna-licensed fashions and accessories. Designer Tommy Hilfiger dispensed his logo-laden sportswear to musicians, who became walking advertisements in music videos; he also collaborated on a fashion show and CD for MTV.

As part of its shift away from 24-hour broadcasting of music videos, MTV attempted to sell clothes in the manner of The Home Shopping Network; and in 1989, launched its fashion program, *House of Style*, with model-host Cindy Crawford, who accepted the position without pay in order to gain more exposure. The show has also helped the careers of subsequent model-hosts including Daisy Fuentes, Rebecca Romijn-Stamos, and Molly Sims. The show, resembling music videos with pumping sound tracks and quick splicing of images, has featured the latest fashions and youth trends. Regular features like “Todd Time” with fashion designer Todd Oldham helped boost designers’ profiles. *House of Style* has also hosted *Fashionably Loud*, a fashion show featuring top models walking the runway in the latest fashions to the beat of the newest music acts. The fusion of music, fashion, and celebrity spawned an awards show on MTV Network’s other music channel VH1; the VH1 Fashion Awards, in collaboration with *Vogue* magazine, first premiered in the mid 1990s.

In the 1990s E! Networks, arguably the largest distributor of entertainment news and lifestyle programming, became a leader in fashion television. By 1998, E! offered almost thirty half-hour fashion segments a week including “Fashion Week,” “Fashion File,” “Video Fashion Weekly,” and “Model TV.” The network also owns The Style Network—a 24-hour channel devoted to fashion, beauty, decorating, and entertaining. Their fashion programming includes makeover shows like “Fashion Emergency” and “Style Court” and covers celebrity fashion with special segments like the popular “Academy

Awards Pre-Show” and “Golden Hanger Awards” both hosted by Joan and Melissa Rivers.

Much of E!’s programming reflects the growing popularity in recent years of lifestyle and makeover shows and programs that focus on celebrity style. Programs such as “Full Frontal Fashion” on Women’s Entertainment (WE), much like the magazine *In Style*, show viewers who’s wearing what by which designers and how to get the look for yourself. Makeover shows like *What Not to Wear* on The Learning Channel (TLC) and *Queer Eye for the Straight Guy* on Bravo have been popular in 2002 and 2003. *The Isaac Mizrahi Show* on the Oxygen network helped put the network on the map while resuscitating designer Mizrahi’s fashion career.

Fashion television has had far-reaching effects on the fashion industry. Fashion reporting like that of Klensch and Beker has brought high fashion into the homes of millions and helped define it for the mainstream. Not only has fashion television launched trends, it has also made designers more attuned to the “telegenic” qualities of their runway shows. It has boosted the profiles of designers and models—even launching the acting careers of many models—putting greater pressure on both to perform well in front of a camera. The proliferation of fashion television programming that exists today attests to the immense appetite of the viewing public to follow fashion, particularly celebrity fashion, as entertainment.

See also **Film and Fashion; Hollywood Style; Music and Fashion.**

#### BIBLIOGRAPHY

- Agins, Teri. *The End of Fashion: How Marketing Changed the Clothing Business Forever*. New York: Quill, 2000.
- Gross, Michael. “Rock Videos Shape Fashion for the Young.” *New York Times*, 27 December 1985.
- Horyn, Cathy. “Vogue Paints a Face on VH1 Awards.” *New York Times*, 7 December 1999.
- Klensch, Elsa, with Beryl Meyer. *Style*. New York: Berkley Group, 1995.
- La Ferla, Ruth. “All Fashion, Almost All the Time.” *New York Times*, 29 March 1998.
- Menkes, Suzy. “Fashion’s TV Frenzy.” *New York Times*, 2 April 1995.
- Parsons, Patrick R., and Robert M. Friedman. *The Cable and Satellite Television Industries*. Boston: Allyn and Bacon, 1998.
- Sheehy, Maura. “No Frills, Meet Fashion Dancer.” *New York Times*, 19 July 1992.
- Spindler, Amy M. “Look Who’s Talking.” *New York Times*, 15 May 1994.

*Tiffany Webber-Hanchett*

**FASTENERS** A fastener is the essential part of a fastening system used to hold together at least two pieces of material. It is typically a single item (button) that often works in concert with another device (buttonhole).



Apparel fasteners may be permanent or temporary. Permanent fastenings, such as stitching and fusing, create form and shape in tailored garments. Temporary fasteners take many forms, including basting used to hold fabrics in place before permanent machine stitching is applied. Temporary fasteners, such as hook and eye closures for bras, can adjust garment size. Zippered fly front openings in men's trousers provide access for bodily functions. However, one most often thinks of apparel fastening as providing a method of "donning and doffing" garments for everyday dressing (Watkins 1995).

In physics terms, friction is the basis for holding solid materials together using one of two methods, applied force or restraining force (Kammermeyer 1967, p. 19). Applied forces are either bidirectional, like the two opposing threads of a lockstitch holding fabric layers together, or radial, like the circular pressure exerted by the female side of a snap fastener (or, in the United Kingdom, press stud). Restraining forces for apparel follow mechanical principals relying on either random surface texture as used in hook-and-loop tape, more commonly known as Velcro, or on functionally configured parts like the teeth of a zipper.

The earliest apparel fastenings can be traced to the Mesolithic era, when needles were used to stitch materials together, and to the age of metals, when evidence of bone buttons and a safety pin-like device are found. The Bronze Age introduced forerunners of the buckle with the brooch and pin concept and the penannular, a sliding pin on a U-shaped element. The first written record of buttons is from the twelfth century (Epstein and Safro 1991). Modern developments have improved on old concepts and added ease and efficiency in fastening garments. The sewing machine increased the speed of stitching fabric pieces together and facilitated production. The zipper, introduced in the late 1800s, has evolved from a bulky mechanism made of metal hooks and eyes, to interlocking metal teeth, to plastic coils, to extruded all-in-one devices. Velcro was invented after World War II and has applications in industry and fashion. New technologies in adhesives and fusibles have influenced the speed of apparel production and the appearance of apparel.

There are many fasteners used in clothing in the early 2000s. Garments are "stitched" together with thread, glue, or fusible substances. Lacing through grommets or eyelets is used in shoes and corsets. Tied or tucked-in fabric ends secure sarongs, saris, and wrap skirts. Clamping devices are used to fasten jewelry to the body. Hook and eye fasteners may be used to add an industrial look to outerwear. Fashion apparel borrows fasteners like C-clamps and D rings from industrial products. Zippers have metal, plastic, or cut-crystal teeth. Buttons, the long-standing epitome of the fashion fastener, provide function with unlimited options in form, color, and texture. Fasteners provide function in garments and often provide the finishing fashion touch.

See also **Closures, Hook-and-Loop.**

#### BIBLIOGRAPHY

- Epstein, Diana, and Millicent Safro. *Buttons*. New York: Harry N. Abrams, 1991.
- Kammermeyer, Michael. "Towards a Theory of Fastening Systems." Master's thesis, California State College at Long Beach, 1967.
- Watkins, Susan. *Clothing: The Portable Environment*. Ames: Iowa State University Press, 1995.

Karen L. LaBat

**FATH, JACQUES** A key figure in the revival of the Paris fashion industry after World War II, Jacques Fath (1912–1954) created colorful and inventive designs catering to a young and sophisticated international clientele who identified with the vitality of his label. Though Fath was regarded as one of the "big three" Paris designers in the early 1950s—along with Christian Dior and Pierre Balmain—his untimely death at the age of forty-two meant that the impact and importance of his work was often overlooked in comparison to that of his contemporaries. While Fath's designs were right on the mark of the glamorous postwar look, it was his attitude toward business and his understanding of the power of publicity and marketing that helped to place this charismatic and flamboyant designer apart from his peers.

Fath was born just outside Paris into an artistic family in 1912. His grandfather was a successful artist named René-Jacques Fath. Although Fath's great-grandmother had also been an artist who occasionally worked in fashion illustration, the designer did little to suppress the rumor that she had been a couturière to the Empress Eugénie. Encouraged by his family to enter the business world, Fath worked for a stockbroker for two years upon finishing his education. After completing a required year of military service, however, he realized that a more creative career lay in store. He spent some time in drama school and also took evening courses in drawing and pattern cutting. During this period Fath met Geneviève Boucher de la Bruyère, a photographer's model and fellow drama student, who became his wife in 1939. She modeled many of Fath's early creations and came to epitomize the elegantly finished style of the Jacques Fath woman.

At the end of 1936, Fath established a couture house in the rue de la Boétie and showed his first collection of just twenty garments in the spring of 1937. The collection was well received and enabled Fath to build up a steady clientele, although he still had something of a hand-to-mouth existence in the 1930s. Guillaume notes that in later years Fath recalled how he often used the money from a deposit on a garment to purchase the fabric to make it.

Fath served in the French Army during World War II. After he was demobilized following the fall of France to the Germans in 1940, however, he continued to run his house on a small scale. Having already moved once, Fath secured a permanent home for his label in an imposing eighteenth-century building on the avenue Pierre Premier de Serbie. In 1945 he created four designs for the Théâtre de la Mode, a traveling exhibition of fashion dolls that showcased the work of the top Parisian couturiers.

An astute businessman, Fath decided to add a line of perfumes to his fashions. He launched his first perfume, Chasuble, in 1945 and his second, Iris Gris, a year later. Recognizing the incredible potential to expand his business in the United States, he signed a contract with the New York manufacturer Joseph Halpert in 1948. Fath contracted to provide two collections a year, each comprising about twenty models to be marketed in large department stores throughout the United States. His popularity in America was further increased when Rita Hayward chose him to design her wedding dress and trousseau for her marriage to Prince Aly Khan in 1949. Fath had a loyal following in Hollywood, and designed the costumes for several movies both in the United States and Europe. His costumes for Moira Shearer in the celebrated film *The Red Shoes* (1948) were considered classics.

An attractive and gregarious person, Fath recognized the importance of associating his label with fantasy and marketing images of a lavish lifestyle that his clients could share. He was often photographed with his beautiful wife at evening events in Paris or basking in the sun on the Riviera. He threw large, sumptuous, themed costume parties at his château, inviting an international mix of socialites, actors, and fellow couturiers—which ensured maximum publicity in the press.

The year 1950 was eventful for the designer, with both the launch of his perfume Canasta and the opening of his boutique. Fath's boutique offered more affordable items, such as accessories, scarves, ties, and stockings. He was also chosen by the Chambre Syndicale de la Haute Couture to become one of five designers, alongside Carven, Desses, Paquin and Piguet, to make up a group of associated couturiers. Later that same year he set up a separate company, Parfums Jacques Fath, to market his growing line of scents. In 1953, preempting similar moves from other designers to target a larger market, Fath made the decision to launch a ready-to-wear collection. The Jacques Fath Université range was inspired by the fast and efficient mass-production methods that the designer had seen in the United States.

Fath's love of the dramatic was evident in his clothes. He drew much of his inspiration from historic costume, the theater, and the ballet. These influences are apparent in his use of the bustle and corsetry as recurring motifs, and in his playful and undulating lines. He perfected a clean and tailored hourglass shape, enhancing it with plunging necklines, sharp pocket details, or dramatic



**Jacques Fath altering dress.** Fath's designs, which frequently drew on historic costumes, were known for their youthful energy and touch of the dramatic. © GENEVIEVE NAYLOR/CORBIS. REPRODUCED BY PERMISSION.

pleats. Fath experimented with asymmetry, pleating, and volume, designing huge voluminous skirts for both day and evening attire. These skirts cascaded from beneath his signature constricted waistline, or appeared as explosions of fabric under large enveloping coats and jackets. Fath's clever use of color ran from discreet juxtapositions of soft colors to loud prints in strong shades. His designs often featured a tartan patterned fabric and a plain fabric combined in one garment and he was unafraid to use bold modern prints to add an extra dimension to the controlled lines of his tailored garments.

Fath's collections of 1948 were notable for rejecting the full New Look silhouette in favor of severe tubular skirts and dresses cut along diagonal lines. His spring collection of 1950 caused a sensation when it was displayed, with dresses featuring a plunging décolletage accompanied by starched wing collars fastened with a bow tie—a suggestive look that later became identified with Playboy bunnies. Fath was extremely fond of fine wool tweed and jersey fabrics for daywear, often draping these materials directly onto a mannequin to create a new design. Rich satins, taffetas, and fine chiffons were his fabrics of choice for evening gowns, and he often used fur, both in trimmings and as full garments, to dramatic effect.

In 1954 Jacques Fath died tragically early at the age of forty-two. He left behind him a fashion empire at the height of its success, with over six hundred employees.

Geneviève Fath valiantly took over the business for a few years, but closed the clothing line in 1957. The Fath name continued as a perfume label until 1992, when it was acquired by a succession of different companies. The most recent owner of the Fath label was the France Luxury Group, who resurrected the clothing line in 2002 in an attempt to restore the success of this once great house.

See also **Fashion Marketing and Merchandising; Film and Fashion; Haute Couture; New Look; Paris Fashion; Perfume; Tartan; Theatrical Costume.**

#### BIBLIOGRAPHY

- Balmain, Pierre. *My Years and Seasons*. London: Cassell and Co., 1964.
- Charles-Roux, Edmonde, et al. *Théâtre de la Mode: Fashion Dolls: The Survival of Haute Couture*. Portland, Ore.: Palmer-Pletsch Associates, 2002.
- Guillaume, Valérie. *Jacques Fath*. Paris: Adam Biro et Paris Musées, 1993.
- Lynam, Ruth, ed. *Paris Fashion, The Great Designers and Their Creations*. London: Michael Joseph, 1972.
- Millbank, Caroline Rennolds. *Couture: The Great Fashion Designers*. London: Thames and Hudson, 1985.
- Steele, Valerie. *Paris Fashion: A Cultural History*. 2d ed. Oxford, New York, and Tokyo: Berg/Oxford International Publishers, 1998.
- Watson, Linda. *Vogue: Twentieth Century Fashion*. London: Carlton Books, 2000.

Oriole Cullen

**FEATHERS** Feathers are the horny outgrowth of skin found on birds. They serve a protective function for birds similar to the scales for fish and hair for mammals. Protecting birds from temperature extremes, feathers also help them fly and differentiate between the sexes.

Feathers are made up of a spiny central structure called the axis and flat side branches called barbs. The axis consists of a quill and a shaft. The quill is the hollow, colorless portion rooted in the skin, from which the feather derives nourishment while it is growing. From the quill to the tip of the feather is the shaft. It is solid and serves as an anchor to millions of barbs or interlocking hooks. This is where most of the color is found.

Feathers come in two main types: contour and down. Contour feathers, the most conspicuous of these types, are found on the wings and tail. The down feathers, considerably softer and fluffier than the contour feathers, are located at the base of the contour feathers.

#### Uses of Feathers

Feathers have had a wide range of uses for thousands of years. Pillows have been filled with feathers and down since around 400 C.E. Until the advent of steel pens in

the mid-nineteenth century, the best writing instruments were made from the quill of goose feathers. Feathers have been used for toys for cats, magic, and medicine bags. But of most relevance to this volume is the use of feathers in personal adornment across time and culture.

**Feathers and symbolism.** In a number of cultures, feathers have assumed great symbolism, often being associated with spirituality. Feather bonnets have been worn in religious ceremonies and ritual dances since the sixteenth century in Brazil.

Feathered spirit masks, made by the Tapirapé of the Amazon, play an important role in dry-season ceremonies performed by the Bird Societies as they circle their village and sing the songs of their respective bird species. For Yanomamö men of the Amazon, their feathered armbands worn high on their upper arms gave them the appearance of having wings, thereby bringing them closer to bird spirits.

The Native American war bonnet was made out of feathers from a golden eagle's tail. This headdress was a symbol of honor, accomplishment, and bravery.

In ancient Egypt, the ostrich feather was a symbol of truth. It was often seen in depictions of Ma'at, the goddess of truth and justice, who passed judgment over the souls of the dead.

**Feathers and fashion.** The Chinese of 500 C.E. used feathered fans. Robin Hood of merry old England wore a feather in his hat. By the late nineteenth century, feathers had become a must-have fashion item around the world, primarily for muffs and hats. The demand for feathers seemed to know no bounds. In 1886, Frank Chapman, an American Museum of Natural History ornithologist, counted feathers or even whole birds adorning 542 out of 700 hats he observed being worn by ladies from New York City. An estimated 5 million birds were killed each year to supply feathers for fashion items according to the American Ornithologists' Union. Bird species were plundered in the United States, Burma, Malaya, Indonesia, China, Australia, New Zealand, and throughout Europe. As a result, some bird species were greatly threatened and several became extinct. The nineteenth-century popularity of the feather muff led to the extinction of the bittern. The huia of New Zealand was extinct by the early twentieth century as well. Populations of snowy egrets and other wading birds were greatly reduced.

#### The Future of Feathers

As a result of the decimation of bird populations all over the world, some environmental concern began to emerge and bird protection laws began to be enacted in the early twentieth century. Queen Alexandra of England made a statement by getting rid of all of her own hats with feathers on them in 1906. In 1918, the Federal Migratory Bird Treaty Act was signed between the United States and



Canada. This treaty limits sportsman to shooting migratory birds no more than three and a half months a year. In 1937 a similar treaty was established between the United States and Mexico. The Endangered Species Act of 1973 contains important provisions for the protection of migratory birds. In addition, international treaties between the United States and Japan and the former Soviet Union protect migratory birds that spend part of their year in the different countries. In the early 2000s most wild birds are protected. It is illegal to use feathers from songbirds (such as chickadees), marsh birds (such as egrets), and birds of prey (such as eagles) in the United States for clothing and accessories.

While the laws undoubtedly helped reduce the number of birds being killed for use in clothing and accessories, perhaps the biggest reason that birds on the endangered species list made a comeback was a change in fashion. In the 1920s, young women cut their hair so short that it could not properly support the large hats that had been decorated with many feathers just a few years earlier. Feathers did reappear on hats in the 1930s, 1940s, and 1950s. By the late 1960s, very few women wore hats on a regular basis. In the early 2000s, less colorful feathers from chickens and ducks are dyed vivid colors. Also, technology has allowed fake feathers and fur to look very realistic.

### Feather Purchase and Care

For those with a passion for feathers, there are many Web sites where customers can buy feathers that look like a golden eagle, which is illegal to kill, but are really dyed and trimmed from legal feathers. Other businesses assure their customers that the feathers were obtained by natural molting and not by killing of birds. The following types of feathers are generally available: duck, goose, guinea hen, macaw, pheasant, turkey, peacock, ostrich, and rooster.

Since cleaning feathers can be quite damaging to them, it is best to take preventive measures to ensure their longevity. Feathers should be stored away from dust, light, and insects in pH neutral boxes, which can be obtained from businesses that sell archival storage materials. Ideal temperature for storage is 60 degrees Fahrenheit to 75 degrees Fahrenheit, with a humidity of 45 to 55 percent. Handling of feathers should be kept to a minimum.

See also **America, North: History of Indigenous Peoples Dress; Fur; Inuit and Arctic Dress; Trimmings.**

### BIBLIOGRAPHY

- Braun, B., ed. *Arts of the Amazon*. London: Thames and Hudson, Inc., 1995.
- Callan, G. O. *The Thames and Hudson Dictionary of Fashion and Fashion Designers*. London: Thames and Hudson, Inc., 1998.
- Gillow, J., and B. Sentence. *World Textiles: A Visual Guide to Traditional Techniques*. Boston: Little, Brown and Company, 1999.

Thomas, N. *Oceanic Art*. London: Thames and Hudson, Inc., 1995.

Tortora, P. *The Fairchild Encyclopedia of Fashion Accessories*. New York: Fairchild Publications, 2003.

*Elizabeth D. Lowe*

**FELT** Felt is a fabric with a long history. It is a wonderfully versatile material. Felt with precise technical specifications is created in factories for industrial use, and yet the same material can be made by hand into beautiful clothing and exquisite works of art.

Felt can only be made from wool (the hair of sheep, camel and goat) or from fibers from the coats of certain other animals including beaver and rabbit. When these fibers are moistened, compressed, and agitated by rolling, beating, or rubbing, they move and become tangled together and form felt fabric. Scales on the outside of the fibers allow them to move in only one direction and prevent untangling. Hot water, soap, and various other chemicals speed the felting process—in fact, the reason why wool sweaters often shrink during washing is because the fibers become felted.

The origin of felt is unknown but is believed to date back to prehistoric times in Central Asia. Felt may have been discovered when wool, shed from wild sheep, was used to soften sleeping areas, and it formed a cohesive fabric, or when the wool on skins used for clothing became matted.

Felt is a good insulator. It is windproof and rain will run off it. It can be cut and will not fray because it has no yarns to unravel. Dense felt is remarkably strong and cannot be pierced by arrows. This property was appreciated by many warriors in the past, who used felt for lightweight shields and armor. Thin felt may tear when stretched, but dense felt can be stretched and molded into various shapes for uses such as hats, boots, and bags.

### The Land of Felt

As in the past, felt plays an integral part in the lives of Eurasian nomads, who live in lightweight felt tents, known in the West by their Turkish name, yurts, but called *gers* in Mongolia. Yurts are domed structures usually sixteen to twenty feet in diameter, made from a wooden framework covered with felt. A yurt can be erected or dismantled in less than an hour and can easily be carried by two camels or yaks. Nomads also use felt for clothing, boots, hats, bags, carpets, blankets, horse paraphernalia, idols, and toys. This practice continued as the nomads settled in villages, and in Mongolia, many nomads now settled in towns and cities still choose to live in yurts.

Traditionally, nomads make felt by spreading wool fibers on a yak skin and wetting them. The wool and skin are wrapped around a pole and rolled by hand or pulled across the ground by a yak or other animal. After the



### THE LAND OF FELT

From about 400 B.C.E., felt was used so extensively in Central Asia that the area was known to the Chinese as “the land of felt.” The goal of Genghis Khan was to unite “the people who live in felt tents,” and by 1206 he ruled the second-largest empire in human history.

wool has formed a cohesive sheet, it is removed from the mat and rolled further until a strong piece of fabric is created. Decorative designs may be added by appliquéing colored felt pieces or by the use of dyed wool in the felting process.

Before the time of the Roman Empire, felt was made in areas north of a line from Scandinavia, down to Italy, across Greece and Turkey, down the Persian Gulf, across Northern India, and up to the northeast tip of China. There is mention of felt in the works of Homer and pictures of felt production in the ruins of Pompeii. Felt was not known in Africa, Australia, or the Americas.

Until the 1960s, handcrafted felt continued to be used in many Middle Eastern areas for hats, boots, clothing, rugs, and wall hangings. The Turkish military wore felt boots until the 1950s. In Iran and Turkey, felt is now associated with an unsophisticated rural lifestyle.

#### Felt in the West

Little is known about felting in Europe prior to the Middle Ages. Felt was generally a low status fabric used for men’s hats, saddle covers, and the linings of helmets. When Charles VII of France wore a beaver felt hat in 1449 after defeating the English at the Battle of Rouen, such hats became so popular (and an indication of a wearer’s social status) that by the late 1500s beavers were extinct in Western Europe. This led to the development of the North American fur trade by British and French explorers and settlers.

To improve the felting properties of beaver fur, pelts were soaked with a mercury compound before the hair was cut from the skin. The mercury evaporated during hat making and was inhaled by the hatters, causing damage to their nervous systems that eventually resulted in madness. This is the origin of the term “mad as a hatter.”

Hats were so much a part of life that, by the 1820s, there were over 200 hat manufacturing companies in London alone. Beaver felt hats declined in popularity at about that time, but until the 1950s, fashion dictated that men should wear wool felt hats and caps outside, and even in many indoor situations.

#### Modern Felt

The development of felting machines in the mid-1800s increased the uses of felt as both a consumer and an industrial material. Machine-made wool felt has been used for hats, slippers, toys, the linings of silverware cases, carpet underlay, washers, gaskets, filters, polishing wheels, drum sticks, piano parts, and felt pens. It is not generally used for clothing in the West, because thick felt is stiff and does not drape well while thin felt will stretch out of shape. One notable exception is the circular skirts with appliquéd poodle designs that were popular in the 1950s. For crafts, ladies’ hats and many other uses, nonwoven fabrics made from synthetic fibers replaced felt in the late twentieth century.

As traditional felt-making is declining and commercial production of wool felt is decreasing, there has been a revival in interest in the study of traditional felt and the production of felt by hand as a craft or an artistic endeavor. Because of its unique properties and the way it can be made by hand, there will always be uses for felt.

See also **Appliqué; Nonwoven Textiles.**

#### BIBLIOGRAPHY

- Burkett, Mary E. *The Art of the Felt Maker*. Kendal, U.K.: Abbot Hall Art Gallery, 1979.
- Gordan, Beverly. *Feltmaking*. New York: Watson-Guption Publications, 1980.
- Laufer, Berthold. “The Early History of Felt.” *American Anthropologist*, n.s. 32, no. 1 (1930): 1–18.
- Sjöberg, Gunilla Paetau. *Felt: New Directions for an Ancient Craft*. Translated by Patricia Sparks. Loveland, Colo.: Interweave Press, Inc., 1996.
- Pufpaff, Suzanne, ed. *Nineteenth-Century Hat Maker’s and Felter’s Manuals*. Hastings, Mich.: Stony Lonesome Press, 1995.

*Julia Sharp*

**FELTING.** See **Felt.**

**FENDI** Fendi is a synonym of fur and revolution, two apparently contradictory concepts. Having accepted the idea of mass consumption, Fendi attempted to provide furs for women of every social position, or nearly so, demystifying the luxury connotations that have always characterized this type of garment.

The story begins at the corner of the Piazza Venezia in Rome in 1925, where there was a small Fendi boutique and, next door to it, a fur and leather workshop, owned by Edoardo and Adele Fendi. By the 1930s they had expanded the business considerably. But the true protagonists of Fendi’s success are their daughters—Paola (b. 1931), Anna (b. 1933), Franca (b. 1935), Carla (b. 1937), and Alda (b. 1940)—who made the Fendi label famous

throughout the world. All five daughters began working in the family business at an early age—between fifteen and eighteen—assuming different responsibilities as required. In 1964 they opened the office on the via Borgognona in Rome, with a large picture of their mother, Adele, in the entrance. In 1965 they began their collaboration with Karl Lagerfeld, the designer who, together with the Fendi sisters, helped develop a renewed interest in furs. During this time, the famous black and brown double “F,” one of the first company logos, was created.

During the second half of the 1950s, ownership of a fur garment was the dream of many women, but following the social changes that occurred in the 1960s and 1970s, fur came to be seen as old-fashioned and bourgeois. An illustration by the well-known painter Giuseppe Novello, outstanding illustrator of Italy’s postwar bourgeoisie, shows a woman at two different stages of her life. In the first image she is young and thin and wears a fitted coat. In the second she is weighted down by the years and stuffed into a large fur. The caption reads “When I first started wanting a fur coat . . . and when I finally had one” (Novello, p. 32).

Lagerfeld, under the sisters’ direction, experimented with materials, patterns, finishes, weight, tanning methods, and colors, so that furs would be seen as something completely new, supported by advanced technological craftsmanship, suited to the needs of a public that wanted more accessible and wearable fashion. In 1966 he scandalized the fashion world by introducing color as a design element: “A colorful fur coat that was not precious but original” (Aragone, p. 92).

One of the characteristics of the Fendi label is the company’s unusual way of working with traditional skins. Fendi designers were continually experimenting on furs and in 1969, with the introduction of their Pret à Porter line, besides the exclusively artisan manufacturing, Fendi succeeded in producing a product accessible to the ordinary consumer: beautiful furs at a limited price.

Fendi used furs that were considered to be of “poor” quality, which the company then reworked and reinterpreted, and expensive skins, such as fox, ermine, mink, and astrakhan, which it transformed using different finishes and colors, so that they no longer were seen as stiff and conservative but as fashionable outerwear.

The same approach was used in the treatment of leather, especially handbags, which although they were luxury items, were made more versatile through the addition of printed patterns, unusual colors, and new designs. In 1968 Classic Canvas was launched, an alternative to leather; then striped colored rubber—beige and black—that became Fendi’s classic colors.

In 1977 Fendi introduced a line of ready-to-wear, known as “365—a dress for every day of the year, for a woman who wants her fur and purse to match her dress.” (Villa). In 1978 they brought out a line of shoes, pro-



**Fendi advertisement.** Italian fashion-house Fendi is best known for bringing furs back into vogue and creating coveted handbags featuring the distinctive double “F” trademark. THE ADVERTISING ARCHIVE LTD. REPRODUCED BY PERMISSION.

duced by Diego Della Valle. In the 1970s Fendi also launched new artisan-made lines: Giano, Astrologia, Pasta, and Selleria, all in limited edition and numbered.

When Adele died in 1978, each of the five Fendi children took over a different part of the business: Paola was primarily interested in furs; Anna, in leather goods. Franca handled customer relations, Carla coordinated the business, and Alda was responsible for sales. In the 1980s, as was the case with many Italian fashion houses, Fendi underwent a period of considerable expansion, involving product diversification and especially licensing. A wide range of products now bore the Fendi label—sweaters, suits, jeans, umbrellas, clocks, ceramics, and household decorations. Stores and boutiques were opened around the world. In 1985 Fendi even produced the uniforms for the Rome police department. That same year they launched their first perfume. In 1987 they introduced the Fendissime line, conceived by the third generation of the Fendi family: Silvia, Maria Teresa, Federica, and Maria Ilaria Fendi. The new line included sportswear, furs, and accessories for younger buyers. In 1989 they opened their



first store in the United States, located on Fifth Avenue in New York City. The following year they introduced a men's perfume and ready-to-wear line.

In 1997 they began making a series of handbags that quickly became cult objects. The most famous is the Fendi "Baguette," inspired by the shape of French bread, and conceived by Silvia Venturini Fendi. A small, minimalist jewel produced in a wide range of materials from horsehide to pearls, in six hundred different versions, it was an extraordinary success, chosen by Madonna, Julia Roberts, Naomi Campbell, and Gwyneth Paltrow. A special baguette called Lision was produced in limited edition, embroidered with an eighteenth-century loom at the speed of only five centimeters per day. The Rollbag, which was wrapped in a transparent case, followed in 1999. The Ostrich bag appeared in 2002 and the Biga Bag, favored by Sharon Stone, in 2003.

Silvia Venturini Fendi, together with Karl Lagerfeld, pursued the Fendi tradition of research in furs. For their Winter 2003–2004 collection they launched, among other furs, the "Vacuum Persian Fur," that is, a fur put into a PVC packaging, a fox fur cut into small stripes and then reassembled with small rubber bands, and depilated mink coats.

Meanwhile a number of licenses that had weakened the company's image were sold and Fendi focused on its core business, leather and fur. The Dark Store is the Fendi concept store based on the company's realignment. Dark Stores could be found in Paris, on rue François 1er and in the Galeries Lafayette on boulevard Haussmann, and on Sloane Street in London in the early 2000s.

Also in the early 2000s Silvia Venturini Fendi, Anna's daughter, was in charge of the style department as creative director of accessories and Man's Line.

In 2001, after considerable legal maneuvering associated with the mergers and acquisitions that typified the fashion world early in the twenty-first century, Fendi became part of the LVMH group, a giant in the world of luxury goods.

Over the years Fendi has designed costumes for both cinema and theater and has worked with a number of directors, including Luchino Visconti (*Gruppo di Famiglia in un Interno* 1975, *L'Innocente* 1976), Mauro Bolognini (*La Dame aux camélias* 1980), Franco Zeffirelli (*La Traviata* 1983), Sergio Leone (*C'era una Volta in America* 1983), Lina Wertmüller (*Scherzo*), Marco Ferreri (*Futuro di Donna* 1984), Dino Risi (*Le bon roi dagobert* 1984), Liliana Cavani (*Interno Berlinese* 1985), Francis Ford Coppola (*The Godfather III* 1999), Martin Scorsese (*The Age of Innocence* 1993, a film that won the Oscar for costumes, in which Michelle Pfeiffer was wearing Fendi furs designed by the costumer Gabriella Pascucci), and Alan Parker (*Evita* 1996, starring Madonna). Wes Anderson's *Royal Tenenbaums* (2001) featured a fur coat worn by Gwyneth Paltrow, that became popular.

See also **Fur; Lagerfeld, Karl; Leather and Suede; Tanning of Leather.**

#### BIBLIOGRAPHY

- Arago, Bonizza Giordani, ed. *Moda Italia: Creativity and Technology in the Italian Fashion System*. Milan: Editoriale Domus, 1988.
- Bianchino, Gloria, ed. *La moda Italiana*. Milan: Electa, 1987.
- Laurenzi, Laura. "Fendi." In *Dizionario della moda 2004*. Edited by Vergani Guido and Gabriella Gregoriotti. Milan: Baldini and Castoldi, 2003.
- Novello, Giuseppe. *Sempre più difficile*. Milan: Mondadori, 1957.
- Villa, Nora. *Le regine della moda*. Milan: Rizzoli International, 1985.

Simona Segre Reinach

**FERRAGAMO, SALVATORE** Salvatore Ferragamo (1898–1960) was an artisan and an innovator during his fifty-year career in footwear design. His family name evokes beauty, traditional craftsmanship, and an assurance of quality and comfort. Born in Bonito, Italy, a remote hill town not far from Naples, Ferragamo was the eleventh in an agricultural family of fourteen children. Since poverty limited the resources needed to sustain a family, many Italians made their own shoes. Young Salvatore was determined to be a shoemaker and served an apprenticeship in a shop where each step was accomplished by hand. Intent on refining his knowledge and craftsmanship, he moved to Naples—at that time a hub for dressmakers, milliners, and shoemakers—in 1909, with the goal of learning accurate methods of measuring, fitting, and aesthetics. While still an adolescent, the imaginative and entrepreneurial Ferragamo returned to Bonito and set up a workshop with six assistants; under his leadership they produced custom-fitted, distinctively designed shoes.

#### Success in the United States

An older brother encouraged Salvatore to join him in Boston, where the Queen Quality Shoe Company hired him in 1914. Although modern technology mass-produced basic footwear, it was, in Ferragamo's opinion, heavy and clumsy. Subsequently he relocated to Santa Barbara, California, where he established a shoe-repair shop with the intent to create custom shoes by hand. Commissions included custom-designed boots and sandals for celebrities and silent film stars from 1914 to 1927.

In 1923 Ferragamo opened the legendary Hollywood Boot Shop in Los Angeles. Celebrities often commissioned outrageous footwear, such as pumps with appliqué patterns or sandals decorated with pearls or feathers. During the 1920s Ferragamo labels could be found in stores like Gimbel's and Saks Fifth Avenue. Ferragamo's standards for measuring and sizing, combined with his originality, influenced the entire industry. Although handmade shoes became an exclusive product for

discerning clientele, he collaborated with American manufacturers to design mass-produced shoes as well.

### Return to Italy

Following fifteen successful and creative years in southern California, Ferragamo returned to Florence, Italy, in 1927 to organize assembly-line production of handcrafted shoes. He took advantage of the inherent qualities of Italian craftsmen and the availability of superior materials to create legendary footwear. In 1940 he returned to his hometown to marry Wanda Miletti, the daughter of the village doctor. Their life together produced a family of six children, all of whom became involved in the family business.

The American stock market crash of 1929 devastated the Italian economy, resulting in Ferragamo's bankruptcy. An undaunted entrepreneur, he managed to reestablish himself in Florence, and by 1937 he was able to purchase the elegant thirteenth-century Palazzo Spini-Feroni, one of the most historic buildings of the city, which became his workplace and showroom. By 1939 four hundred employees produced two hundred pairs of handmade shoes per day. Florence was once again a popular tourist destination by 1950, and international clientele frequented the elegant Ferragamo shop on via Tornabuoni.

### A Family Business

Although Ferragamo's eldest daughter, Fiamma, had studied classics at the university, she observed all stages of her father's business from an early age. Following his death in 1960, she assumed responsibility for 700 workers who produced 350 pairs of shoes a day. The labor-intensive practice of making shoes by hand vanished by the end of the 1960s. Her sister Giovanna had studied fashion design in Florence, preparing for the eventuality of apparel as a new direction for the family business. Motifs from classic Italian art inspired her patterns and colors for an early signature collection of ready-to-wear for women in 1959. In the 1970s the company expanded into producing small leather goods, luggage, scarves, and perfume for the international market, in addition to footwear.

In the early twenty-first century the heirs continued to conduct business from the Palazzo Spini-Feroni. Wanda presided as chairman, and her son Ferruccio was the chief executive officer. Fiamma died prematurely in 1998 after almost forty years as the vice president responsible for product design. Her visionary initiatives built the company from a custom-made shoe business for the privileged few to a global, privately owned corporation. Today the company produces high-quality ready-to-wear and fashion accessories in addition to men's and women's footwear, all of which is available in exclusive and flagship stores around the world through joint ventures and licensing agreements. In addition the company subsidizes cultural restorations and sponsors international competitions for young shoe designers.

### Personal Image and Acknowledgments

Wanda Ferragamo recalled that her husband was motivated by faith in his abilities. He was strong-willed and optimistic, determined to prosper. His workers remember that he transmitted confidence, and although he demanded discipline, he also recognized merit. He did not sketch his ideas, but as a great improviser and engineer, he intuitively cut samples and draped materials on wooden shoe forms to convey original ideas to his production staff.

In 1948 an exhibit at the Palazzo Strozzi in Florence, displaying two hundred models of Ferragamo's footwear produced between 1927 and 1960, was installed. Each pair was presented as a work of art. The exhibition traveled internationally and became the foundation of the archives in the Museo Ferragamo at the corporate headquarters. In 1999 the company won the Guggenheim Enterprise and Culture Prize for its investments in the sphere of culture.

### Clothing Designs and Artistic Hallmarks

Ferragamo's autobiography, *Shoemaker of Dreams*, first published in England in 1957, details his career. As a true artist, Ferragamo found ways to create even under the most limited conditions. During World War II, restricted to using only the poorest of materials, he became known for his inventive use of what was at hand. Hemp cord and the strong, multicolored cellophane wraps of candy and cork were readily available in this region of wine making. He ingeniously placed the supportive metal shank precisely in the instep of the shoe, freeing the joints and heels from supporting body weight. Weightless qualities of both design and construction became Ferragamo's hallmark. He sculpted cork into wedge platforms and heels and dyed raffia to be woven for upper constructions. In 1947 he appropriated the clear filament wire used by fishermen to create straps around the foot and ankle to create the illusion of a seductive, feminine "Invisible Shoe."

In 1938 Ferragamo tapped into the allure of the prevailing theme of Orientalism. He created an upturned toe that he called the Oriental mule. He patented shoes with heels fabricated in steel. He coined the term *shell soling* for upturned soles. Narrow toes and slim high heels counterbalanced the voluminous gowns of designer Christian Dior, creator of the New Look of 1947. Ferragamo introduced a sculptural high heel carved into an F, his signature letter. In 1961 Fiamma collaborated with the up-and-coming Florentine noble, Emilio Pucci, on a display that accessorized colorful and vivacious garments with footwear. Fiamma Ferragamo is the creator of the most popular shoe style ever produced by the company: the *Vara*, a practical, midheel pump adorned with a signature metal buckle and stamped with the family signature and grosgrain bow, remains a wardrobe staple today.

Ferragamo stressed that his success was based in technical expertise and a discerning sense for materials,

combined with a knowledge of anatomy and his admiration for the allure of the female leg and foot. In the early 2000s the company continued to produce high-quality products made of superior materials with the same sophisticated standards originally established, sustaining the legacy of a truly unique man.

See also **Orientalism; Shoemaking; Shoes.**

#### BIBLIOGRAPHY

Angioni, Martin. *Fashion and Art Newspaper*, no. 76, December 1997, p. 21.

Ferragamo, Salvatore, Stefania Ricci, and Edward Maeder. *Salvatore Ferragamo: The Art of the Shoe, 1898–1960*. New York: Rizzoli, 1992. An exhibition catalog.

———. *Shoemaker of Dreams: The Autobiography of Salvatore Ferragamo*. New York: Crown Publishers, 1972.

Stengel, Richard. “The Shoes of the Master.” *Time* 139, no. 18 (4 May 1992): 72.

Gillion Carrara

**FETISH FASHION** Fetishism is a term with a long and complicated history, encompassing religious, anthropological, economic, and sexual meanings. Missionary tracts with titles such as *Fetishism and Fetish Worshipers* denounced the “barbarous” religions of “primitive” people who worshiped “idols of wood or clay.” The term fetish was then extended to refer not only to objects allegedly possessing magic powers, but also to anything that was irrationally worshiped. Karl Marx famously coined the term “commodity fetishism” to describe the way objects produced through human labor acquired an exaggerated exchange value. Sexologists and psychiatrists traditionally described fetishism as a sexual “perversion.” Today, fetishism is usually characterized as a type of variant sexuality, in which arousal is associated with a (nongenital) part of the body, such as hair, or an inanimate object, such as a shoe.

Experts tend to agree that the majority of sexual fetishists are men. Indeed, the psychiatrist Robert Stoller argued, “fetishizing is the norm for males, not for females.” However, the subject of female fetishism is of interest to cultural theorists. There are also thought to be degrees of fetishism. Many men may be sexually aroused by high-heeled shoes, for example, but only a minority require the presence of such shoes for sexual arousal—and even fewer women have such a directly sexual relationship with shoes. Fetishism has also been associated with sadomasochism and transvestism. Leather fetishists, for example, may be involved in sadomasochistic sexuality. Sigmund Freud argued that fetishism was caused by castration anxiety, but this theory is not widely accepted today.

High-heeled shoes, so-called “kinky” boots, corsets, lingerie, and garments made of leather or rubber are among the most common clothing fetishes. Sometimes



**Woman modeling Thierry Mugler rubber dress.** Rubber clothing is a standard of fetish fashion, as are kinky, extremely high-heeled shoes or boots. © PIERRE VAUTHEY/CORBIS. REPRODUCED BY PERMISSION.

individual clothing fetishes are combined; thus, a black leather corset might be worn with high-heeled boots and long rubber gloves. Fetishes are associated with particular sexual fantasies. Or as Stoller put it: “A fetish is a story masquerading as an object.” In the nineteenth and early twentieth centuries, fetish clothing was utilized in secret sexual scenarios; for example, in brothels or the staging of pornographic imagery. Since the 1970s, however, clothing fetishes have played an increasingly important role in fashion and popular culture. As early as the 1960s, the television program *The Avengers* featured a character, Mrs. Peel, who wore a black leather catsuit that was modeled on an authentic fetish costume. Mrs. Peel’s costume was a precursor of Michelle Pfeiffer’s latex catsuit and mask in the film *Batman Returns*.

Fetishism moved from the sexual underground into mainstream popular culture via subcultural groups such as punks and leathermen. A youth subculture associated with bands like the Sex Pistols, the punks appropriated fetish clothing as part of their own “style in revolt.” The fashion designer Vivienne Westwood, herself a punk,



opened a shop in London called Sex, where she sold bondage trousers, rubber stockings, corsets, and extreme shoes to a clientele divided between real fetishists and young people attracted by the idea of breaking taboos. Westwood herself wore “total S&M as fashion” in the early 1970s, not just in private or at clubs, but on the street, as a way of subverting accepted social values.

The 1970s saw the spread of sexual liberation, women’s liberation, and gay liberation—all movements that provided a context for the emergence of fetish fashion. Although many feminists regard fetish fashion as exploitative and misogynistic, the iconography of sexual fetishism unquestionably focused on images of powerful women. The image of the dominatrix or phallic woman was especially pronounced in the work of Helmut Newton, a very influential fashion photographer of the 1970s. As a result of his controversial pictures in magazines such as the French edition of *Vogue*, Newton is often credited with having made fetishism “chic.” One of his fashion photographs of 1977, for example, was titled “Woman or Superwoman?” It showed a woman wearing a leather trench coat by French designer Claude Montana, accessorized with riding boots to convey the image of an Amazon, a subcategory of the dominatrix.

Jean Paul Gaultier is another designer who pioneered fetish fashion in the 1980s. Gaultier has told interviewers that, as a child, his grandmother’s flesh-colored corsets fascinated him, and he describes the process of lacing a corset as ritualistic. Many of his designs for both men and women have featured corset-style lacing. He is probably most famous for the corset that he designed for Madonna’s Blonde Ambition tour, which helped launch the trend for underwear-as-outerwear. Lingerie, of course, has become a ubiquitous influence on fashion

Perhaps even more than Gaultier, Thierry Mugler has focused on corsetry and on fetishized materials such as rubber and leather to create costumes that evoke the image of “the phallic woman.” One of his couture ensembles was entirely handcrafted of leather, including a leather neck-corset. It resembled the carapace of an insect. Other hard-bodied styles include metal corsets and entire ensembles made of metal and plastic, which transform the wearer into a kind of armored cyborg. Indeed, there is virtually no fetish ensemble—from the clothing of the equestrienne to the military uniform—that has not appeared on Mugler’s runways.

Leather is the material most often utilized in fetish fashion. Claude Montana was among the first to become known for fetish leather, to be followed in the 1990s by the Italian designer Gianni Versace, who caused a sensation with his leather fashions. Is it “chic or cruel?” asked *The New York Times*. Similar styles had been pioneered by sadomasochists, especially gay leathermen. Designers such as Thierry Mugler and John Galliano for Dior have also incorporated other second-skin materials, such as latex, into high fashion. All of the designers mentioned are

also known for their “kinky” shoes and boots, which are the most important accessories in the wardrobe of fetish fashion. Fetish shoes typically feature extremely high heels and sometimes also high platforms and ankle straps or lacing that allude to bondage. Fetish boots tend to be either very high (to mid-thigh) or overtly aggressive-looking.

*See also* **Fashion and Homosexuality; Film and Fashion; Galliano, John; Gaultier, Jean-Paul; Madonna; Mugler, Thierry; Versace, Gianni and Donatella; Westwood, Vivienne.**

#### BIBLIOGRAPHY

- Gammon, Lorraine and Merja Makinen. *Female Fetishism*. New York: New York University Press, 1994.
- Kunzle, David. *Fashion and Fetishism*. Totowa, N.J.: Rowman & Littlefield, 1982.
- Lafosse-Dauvergne, Geneviève. *Mode et fétichisme*. Paris: Éditions Alternatives, 2002.
- Steele, Valerie. *Fetish: Fashion, Sex & Power*. New York: Oxford University Press, 1996.
- Stoller, Robert. *Observing the Erotic Imagination*. New Haven, Conn.: Yale University Press, 1985.

*Valerie Steele*

**FIBERS** According to the American Society for Testing and Materials (ASTM), a fiber is a unit of matter that has a length of at least 100 times its diameter. If fibers are to be used in textile products, they must have characteristics of fineness, strength, cohesiveness, and flexibility appropriate to the projected end use. Chemically, fibers are composed of long chains of molecules called polymers.

Fibers may be found in nature or manufactured. Fibers may be short and noncontinuous or of indefinite length, long and continuous. Short fibers are called staple fibers, while long, continuous fibers are called filament fibers. All natural fibers except silk are staple fibers. Manufactured fibers and silk can be filament fibers or can be cut into staple lengths.

Humans have used natural fibers since prehistoric times. Fibers are often classified according to their chemical structure. Natural fibers obtained from plants are generally made of cellulose. Others, generally obtained from animal hair, are protein. One mineral fiber, asbestos, is obtained from rock deposits. Asbestos products are no longer manufactured in the United States because the fibers can be carcinogenic if inhaled.

Natural cellulosic fibers are classified as seed hair fibers (cotton and kapok) because they grow on seeds. Bast fibers are obtained from the stems of plants (linen from the flax plant, ramie, jute, hemp, and kenaf). Fibers from plant leaves and other vegetable sources include agave, coir, henequen, sisal, yucca, piña, and sacaton. Many of these fibers, and others that are even more rare,

have only limited use for industrial products or for local crafts. Cotton, linen, ramie, and hemp are the cellulosic fibers most often used in apparel. Piña comes from the leaves of the pineapple plant and is used for traditional costumes in some Asian and Pacific areas.

Protein fibers are generally obtained from the hair of animals. Silk, another protein fiber, is extruded by the silkworm and obtained from its cocoon. Widely used animal hair fibers include sheep's wool, cashmere, camel hair, mohair, and alpaca. Other animal hair fibers have more limited use. Eskimo women knit qiviut, the soft, fine underhair of the musk ox, into very expensive accessories and garments, using patterns characteristic of their village. Llama and guanaco, Andean animals that are similar to alpaca, and *buarzio* and *misti*, cross-bred llamas and alpacas, produce hair harvested for textiles. Attempts to domesticate the vicuña, a wild Andean ruminant, have had limited success. Most of this very soft and costly fiber comes from animals that have been hunted, and strict limits are placed on the number that can be taken each year. In New Zealand, cross-breeding female cashmere goats and male angora goats has produced "cashgora," but marketing efforts for this fiber have had limited success.

Manufactured fibers (sometimes called man-made fibers) can be either regenerated fibers, those formed from natural materials that are not useable as fibers in their natural form, or synthetic fibers from chemical substances. Most manufactured fibers are formed either by melting or dissolving the polymer in a chemical solution, then forcing this solution through holes in a metal plate, called a spinneret, in order to form long, continuous fibers.

The manufacture of a regenerated fiber begins with such diverse substances as cotton fibers too small to be formed into a yarn, wood chips, corn or milk protein, or seaweed. These materials are subjected to chemical processing that allows them to be dissolved and then reformed into filament fibers. The most widely used regenerated fibers include rayon, lyocell, and acetate.

Synthetic fibers are created (synthesized) from chemical substances. The Federal Trade Commission classifies synthetic and manufactured fibers according to their chemical composition. Manufacturers may also give their fibers trade names. The most widely used synthetic fibers are acrylic and modacrylic, elastomers, nylon, polyolefins, and polyester.

Metallic fibers have been used in fashionable apparel for thousands of years, often to make lavish garments to display status. Thin sheets of metal can be cut into narrow strips or a thin filament of metal can be wound around a central core of another material. Except for gold, metal fibers are likely to tarnish unless provided with a protective coating.

Some high-tech fibers with limited use in apparel are aramid, PBI (Polybenzimidazol), melamine, and sulfur.

These are used for protective clothing or gloves. Bicomponent fibers are made from two different polymers, combined in various configurations in order to take advantage of the special characteristics of each fiber.

Fibers are made into textiles by techniques in which the fibers are held together or formed into a yarn and the yarns formed into a fabric by any of a number of techniques.

See also **Acrylic and Modacrylic Fibers; Alpaca; Camel Hair; Cotton; Elastomers; Hemp; Nylon; Polyester; Silk; Techno-Textiles.**

#### BIBLIOGRAPHY

*Annual Book of ASTM Standards*, Volume 07: *Textiles—Yarns, Fabrics, and General Test Methods*. (Standard Terminology Relating to Textiles.) Philadelphia: American Society for Testing and Materials, 2002.

Collier, B., and P. Tortora. *Understanding Textiles*. 6th ed. Upper Saddle River, N.J.: Prentice Hall, 2001.

Hongu, R., and G. Phillips. *New Fibers*. Manchester, U.K.: Woodhead Textile Institute, 1998.

Lewin, M., and E. Pearce. *Handbook of Fiber Chemistry*. New York: Marcel Dekker, 1998.

Moncrieff, R. W. *Man-Made Fibres*. London: Newnes Butterworth, 1975.

Tortora, P., and R. Merkel. *Fairchild's Dictionary of Textiles*. New York: Fairchild Publications, 1996.

Phyllis Tortora

**FILM AND FASHION** The couturier and designer of surreal hats, Elsa Schiaparelli once declared, "The film fashions of today are your fashions of tomorrow" (Prichard 1981, p. 370). Besides planning haute couture collections, Schiaparelli also designed costumes for such stars as Mae West (*Every Day's a Holiday* [1937]) and the British stars Margaret Lockwood and Anna Neagle (*The Beloved Vagabond* [1936], *Limelight* [1936]). Since then, the interrelationship between film and fashion has become more complex. Schiaparelli's belief in the direct influence of the "dream factory" on what ordinary people wore is borne out by a number of examples from the classical Hollywood period: one of Adrian's robes for Joan Crawford in *Letty Lynton* (1932) was widely copied, as was Edith Head's white party dress for Elizabeth Taylor in *A Place in the Sun* (1951). However, since then various factors have enriched and diversified fashion's interaction with film. First, there was—in the wake of Audrey Hepburn's successful collaboration with the then young and relatively unknown Paris couturier Hubert de Givenchy from *Sabrina* (1954) onward—the growing use of fashion as opposed to costume design on a number of key movies. Second, alongside this industrial shift and commensurate with the expansion within the couture industry into prêt-à-porter, there was an escalation of fashion's influence over film as well as the other way round. Third (and a

far more contemporary factor) is the rise in celebrity culture and a burgeoning interest in movie stars, what they wear both on and off the screen.

From the 1920s through the 1940s, relatively few fashion designers demeaned themselves by working for moving pictures. The most notable Parisian export was Coco Chanel who, in 1931, was lured to Hollywood by Sam Goldwyn for \$1 million, only to find that Hollywood costume design—because she was too meticulous, too precise—was not for her. When she returned to France, Chanel did return to costume designing, working on the films *Les Amants* (1958) and *L'année dernière à Marienbad* (1961). Despite the phenomenal impact on cinema as well as fashion of his New Look in 1947, Christian Dior lent his designs to a relatively small and eclectic series of films: René Clair's *Le silence est d'or* (1946), for example, some of the costumes for Jean-Pierre Melville's *Les enfants terribles* (1950), and Marlene Dietrich's costumes for Alfred Hitchcock's *Stage Fright* (1950). It was Givenchy's collaboration with Hepburn that changed everything.

Called in reputedly at Hepburn's behest, Givenchy's first film costumes were the ball gowns in *Sabrina*. The details of this story are muddled because Givenchy's account of his input in the film at times directly contradicts the version proffered by the film's overall costume designer, Edith Head. Head, who had designed the costumes for Hepburn's Oscar-winning role as the princess in *Roman Holiday* just the previous year, was clearly hurt by the star's—and director's—decision to acquire an actual Paris wardrobe for *Sabrina*. In *The Dress Doctor*, Head comments: "I had to console myself with the dress, whose boat neckline was tied on each shoulder—widely known and copied as 'the *Sabrina* neckline'" (Head and Ardmore 1959, p. 119). Elsewhere, Givenchy queried Head's claim to the *bateau* neckline design. Certainly it is a more eye-catchingly cut than one might expect from Head who, having found her so-called breadline, rationing-conscious costumes of World War II made to look *démodé* by the immediate impact of Dior's opulent New Look, declared herself to be a "fence-sitter" who would follow rather than lead fashion. This claim by Head that she intentionally occupied the middle of the road crystallizes the difference between the couturier and the straightforward costume designer. While the couturier might be more expressive and daring when designing for the screen, costume designers opted for safer styles that remained secondary to character and narrative and never, as the Hollywood director George Cukor commented, "knocked your eye out" (Gaines and Herzog 1990, p. 195). The inherently spectacular quality of Givenchy's designs for Hepburn is frequently accentuated by the nature of the narratives the costumes serve. In both *Sabrina* and later *Funny Face*, the story revolves around the Hepburn characters' Cinderella-esque rags-to-riches tales, transformed from a chauffeur's daughter to a millionaire's wife in one, bookshop assistant to an icon of glamour and

sophistication in the other. The joke in *Funny Face*—in which Hepburn's character models clothes on a Paris catwalk—is ultimately that, for all the appeal of high fashion, Hepburn is happiest (and most iconic) when dressing down in black leggings, turtleneck, and flats.

There have been other significant collaborations between stars and designers—Adrian's partnerships with Greta Garbo and Joan Crawford, or Jean Louis's designs for Doris Day's comedies of the late 1950s and early 1960s—and following these, couturiers contributed more regularly to film costume design. Hardy Amies (Queen Elizabeth's favorite fashion designer) designed the wardrobe for films such as *The Grass Is Greener* (Stanley Donen, 1960) and *2001: A Space Odyssey* (Stanley Kubrick, 1968). Giorgio Armani later became the most prolific couturier costume designer, working on a number of films, ranging from *American Gigolo* (1980) to the remake of *The Italian Job* (2003). However, the way in which Armani has approached costume design—and this holds for several classic designers such as Nino Cerruti, Yves Saint Laurent, Donna Karan, Calvin Klein—is in a likewise classic way. His costumes occupy a traditional, servile role in relation to the narratives and characters they serve; they remain stylishly unobtrusive and do not "knock your eye out," as arguably Givenchy's extravagant ball gowns for Hepburn do. Cinema's most popular couturier costume designers, it seems, are those who follow the underpinning conventions of costume design.

From the 1970s onward, a schism has become increasingly apparent between the classic and the spectacular look in film. Peter Wollen has argued that only the latter kind of extrovert costume design (such as those in William Klein's 1966 film *Qui êtes-vous, Polly Maggoo?*) can be considered art, thus echoing Saint Laurent's belief that "Art is probably too big a word for fashion. Fashion is a craft, a poetic craft" (Saint Laurent 1988, p. 20). The "art" of fashion in film would be exemplified by the film work of Jean Paul Gaultier, who has designed costumes for various art-house movies including *The Cook, the Thief, His Wife and Her Lover* (1989) and *Kika* (1993). In both, exaggerated versions of Gaultier's signature styles—his cone bras, his use of corsetry as outer clothing, his asymmetrical cutting, his persistent predilection for classic tailoring alongside much more radical designs—are evident with a pervasive, more nebulous interest in creating outlandish costumes in their own right. Gaultier's designs are intrinsically fashionable and extend the boundaries of costume and style (as Chanel once explained, there is an essential distinction to be drawn between "fashion," which is ephemeral, and "style," which endures). Although Gaultier trained with Pierre Cardin and Jean Patou (thereby explaining his residual interest in traditional tailoring), in *The Cook, the Thief* alone one can find a string of witty, audacious juxtapositions—there are echoes of Courrèges's space-age costumes (far more outlandish than Amies's designs for *2001*), the influence of the effete cavaliers and more than a whiff of seventeenth-century cardinals. In



*Kika*, the smooth surface of classicism—exemplified by Victoria Abril’s black bias-cut dress—is ruptured by radical flourishes, such as the prosthetic breasts bursting out of it.

The creation of self-consciously spectacular costumes (less “over the top” than drawing attention to themselves in whatever way) has persisted through a variety of eclectic movies. Gaultier’s own wardrobe for Luc Besson’s *The Fifth Element* (1997) is incontrovertibly spectacular; the clothes are ostentatious, wildly colorful, eclectic and, again, overtly sexual, as in Leeloo’s artful stretch-bondage gear. Once more, these costumes flagrantly come in the way of character identification as one cannot help but notice them, and in their very styles (asymmetric, clashing) and man-made fabrics, they proclaim their ephemerality. This is only one, obvious, use of the spectacular; other more subtle examples from within contemporary film of costumes that draw attention to themselves and so intrude upon the seamlessness of the classical narrative form would be *The Talented Mr. Ripley* (1999), *Far from Heaven* (2002), and *Dolls* (2002). Like Luis Buñuel’s *Belle de jour* (1967) before them, *Ripley* and *Far from Heaven* in particular make use of costumes that are only slightly out of the ordinary. The cardigan trimmed with thick, swirling braid that Cate Blanchett is wearing when she bumps into the only slightly less ostentatiously dressed Paltrow is a further example of a costume’s overt fashionableness being used to prevent the spectator’s unthinking identification with the characters and the scene. Fashion (and it is important that the character Blanchett plays here is a textiles heiress) creates an alternative dialogue between text and spectator.

However, it is perhaps not altogether surprising that the dominant tendency in cinema has been to follow the Armani route, using fashion to denote stylishness and class but not to be too spectacular and so interrupt the flow or balance of a scene. For *The Italian Job* (2003), Armani’s costumes are used, very traditionally, as a means of interpreting character. Essential differences between the principal characters are signaled through costume, in much the same way as Edith Head created a shorthand for understanding her characters through dress (a high-buttoned neckline for a repressed woman, a shimmering décolleté dress for a more sexually available one). So, Donald Sutherland’s sensuous, unstructured wool coat and warm turtleneck sweater serve as coded references to his innate charm and old-school heist-master values (he has had enough of the criminal life and the “job” at the start of the film is meant to be his last before going straight), while Mark Wahlberg’s tighter-fitting, slightly spivvy black leather jacket quickly makes him out to be eager and on the make. Armani had used a similar system of typeage for the four protagonists in *The Untouchables* (1987)—the friendly father-figure in chunky knits, the nerd in a coat slightly too big, the cop from the wrong side of the tracks in his rather-too-jazzy brown leather jacket, and the dependable leader (again) in his flowing Armani coat and tailored three-piece.

The dressing of Gwyneth Paltrow in many of her films conforms to a similar pattern. Apart from her period films (*Emma*, *Elizabeth*) and latterly *The Royal Tenenbaums* (2001), in which she appears to be signaling her desire to break free of her previous typecasting, Paltrow has exemplified a certain well-groomed, affluent but slightly frigid and repressed look, given to her in films such as *Sliding Doors* (1998) or Alfonso Cuarón’s modern-day *Great Expectations* (1998) by the elegant but unexceptional designs of Calvin Klein and Donna Karan respectively. These designers, like Ralph Lauren before them, exemplify a specific kind of safe but sophisticated New York fashion. Like costumes in Hollywood’s heyday, the clothes in these films accomplish the easy, unobtrusive creation of Paltrow’s characters’ social identity. The straight lines, modern fabrics, and neutral colors do more than suggest the characters’ fashionableness, they mark them out as coming from a specific milieu, in much the same way as Head’s costumes for Grace Kelly in her Hitchcock films of the 1950s (*Rear Window*, *Dial M for Murder*, *To Catch a Thief*) had done.

The refined, slightly aloof elegance of Grace Kelly could perhaps have been expected to make a bigger impact on fashion itself than it did. The relationship between fashion and film is a two-way process: fashion designers get involved in films in part to showcase their designs and perhaps influence fashion outside cinema along the way. Armani, for example, has denied that his film designs are product placement, although the association with movies is a tidy way of giving his designs exposure. Films, even the less clearly fashionable ones, have frequently influenced fashion. There are multiple examples throughout cinema history of items of clothing in films making a significant intervention into fashion on the street. Some films (such as Michelangelo Antonioni’s quintessentially 1960s’ *Blowup*) are notable as “time capsules” of the fashions of their times, while others might add a look, a garment, or accessory to the contemporary fashion scene. The latter are more intriguing, as they are actively rather than passively engaged with fashion. Sometimes, though, the precise reason for a film having a significant impact on fashion might remain elusive; it simply captures the zeitgeist.

An early example of a single garment changing the course of fashion occurs in *It Happened One Night* (1934) in which Clark Gable takes off his shirt to reveal that he is not wearing an undershirt underneath (reputedly because he felt that taking off another shirt would prove ungainly). Undershirt sales in the United States plummeted by 30 percent. Male underwear sales went up again in the 1950s when the white T-shirt became a fashionable item of male clothing, with Marlon Brando sporting one in *The Wild One* (1953) and James Dean another in *Rebel without a Cause* (1955). Later examples of films directly impacting on fashion are *Annie Hall* (1977) and *Out of Africa* (1985). Just months after the respective releases of both films, the pages of American and British

*Vogue* were awash with derivative images. The distinctive, ditsy look Ralph Lauren created for Diane Keaton as Annie Hall was swiftly mimicked in fashion magazines and in department stores as women were urged to mix up masculine and feminine styles as Annie had done—a big tweed jacket over a feminine shirt, or a waistcoat and tie over peg-top trousers to accentuate rather than obscure the feminine form. In the wake of *Out of Africa*, both in the pages of glossy magazines and on the street, the safari look dominated women's and men's fashions alike. Fashion shoots had safari settings and ensembles featuring billowing linen, cotton shirts, wide skirts, breeches, and leather riding boots. A clear reason for the fashion success of both these films was that their looks were easily attainable; the British store Top Shop tempted shoppers to its *Out of Africa*-inspired collection with the tag line "Out of Oxford Circus, into Top Shop." Likewise, women and girls could achieve the androgynous Annie Hall look by simply raiding the wardrobes of their older, more traditional male relatives or by visiting thrift shops.

Two issues emerge from the impact a film such as *Out of Africa* had on fashion: that it still, despite being a period film, exerted considerable influence on contemporary fashion and that its wardrobe manifestly illustrated the importance of accessibility and democratization when it comes to film's influence on fashion. Few costume films have influenced fashion—although Edward Maeder makes a case for the 1933 version of *Little Women* leading to the popularization of such items as the gingham pinafore, and John Fairchild, publisher of *Women's Wear Daily*, waged a personal crusade in the late 1960s to have hemlines drop after enjoying *The Damned* (1962), *Doctor Zhivago* (1965), and *Bonnie and Clyde* (1967) (Prichard, 216). It is tempting to presume that any period piece that influences fashion must contain elements of inauthenticity: Julie Christie's "swinging sixties" makeup and hair in *Far from the Madding Crowd* (1967) or the anachronistically colorful gowns Michelle Pfeiffer wears in *The Age of Innocence* (Hollander 1993). If such period films have affected contemporary fashion, there has tended to be a manifest overlap between the fashions of the historical period and the fashion trends at the time the film is made. This mutuality was evident in the safari clothes of *Out of Africa* and was logically the reason for *Moulin Rouge*, with its basques and retro-new romantic styles, having been readily emulated in shop windows. While costume films have indirectly influenced designers (Kubrick's *Barry Lyndon* [1975] has been cited more than once as an inspiration by modern couturiers), the films rarely impact upon clothes styles as a whole.

The accessibility of film fashion has become a hugely significant factor in their appeal. In the 1970s and 1980s, fashion had become about what people wear, not what they might fantasize about wearing, a transition that altered the relationship with film. Quentin Tarantino's *Reservoir Dogs* (1992), which inspired London department

store windows and led to an increase in the wearing of dark suits and shades amongst younger men, is just such an example of film's democratization of fashion; the costume designer Betsy Heimann had bought the suits cheaply. As *Reservoir Dogs* became successful as a movie, however, so did the clean-silhouetted French gangster look (Tarantino readily admitted to having emulated the look created by the French director Jean-Pierre Melville for his gangsters). By the time Tarantino came to make his second film, *Pulp Fiction* (1994), the idea that his films were trendy was cemented, and this time he bought suits for Samuel L. Jackson and John Travolta and Uma Thurman's black trousers and white shirt duo at *Agnès b.* Audiences now somewhat randomly scavenge films for fashion ideas, so Thurman's Chanel Rouge Noir nail polish in *Pulp Fiction* was much in demand, as earlier Tom Cruise's sunglasses from *Top Gun* (1986) had been. The overall attractiveness of the film is only partly responsible for its potential impact on fashion; sometimes just a single garment or accessory becomes popular, such as Keanu Reeves's mobile phone and long black coat in *The Matrix* (1999) or Nicole Kidman's half-fitted, half-loose teddy in *Eyes Wide Shut* (1999), which sold out everywhere. As Schiaparelli noted back in the 1930s, cinema is inevitably going to influence fashion. Since then, a more fluid, flexible interaction has emerged—sometimes fashion borrows from film, but often the exchange is reversed. Film actors are inevitably dressing up, and this use of clothes as fantasy comes out in audiences' acquisitions of particular on-screen looks, whether this be women using patterns to make up their favorite costume designs in the 1940s or their granddaughters going to Agnès b. in the 1990s to find Uma Thurman's trousers. Likewise, as Jean Paul Gaultier has remarked, film lets the designer's imagination run riot in a way fashion, because of its commercial constraints, does not. In the early twenty-first century, there is the added dimension of what stars wear off-screen becoming as important in influencing cinema audiences. Film and fashion will continue to serve each other.

See also **Actors and Actresses, Impact on Fashion; Celebrities; Hollywood Style.**

#### BIBLIOGRAPHY

- Bruzzi, Stella. *Undressing Cinema: Clothing and Identity in the Movies*. London and New York: Routledge, 1997.
- Gaines, Jane. "Costume and Narrative: How Dress Tells the Woman's Story." In *Fabrications: Costume and the Female Body*, 180–211. London and New York: Routledge, 1990.
- Gaines, Jane, and Charlotte Herzog, eds. *Fabrications: Costume and the Female Body*. London and New York: Routledge, 1990.
- Head, Edith, and Jane Kesner Ardmore. *The Dress Doctor*. Boston and Toronto: Little Brown and Company, 1959.
- Hollander, Anne. *Seeing Through Clothes*. Berkeley: University of California Press, 1993.
- Maeder, Edward, ed. *Hollywood and History: Costume Design in Film*. Los Angeles: Thames and Hudson, Inc., 1987.

Prichard, Susan Perez. *Film Costume: An Annotated Bibliography*. Metuchen, N.J., and London: Scarecrow Press, 1981.

Saint Laurent, Yves. *Yves Saint Laurent: Images of Design*. With an introduction by Marguerite Duras. London: Ebury Press, 1988.

Wollen, Peter. "Strike a Pose." *Sight and Sound* 5, no. 3 (March 1995): 10–15.

*Stella Bruzzi*

**FIRST LADIES' GOWNS** For over one hundred years, one of the Smithsonian Institution's most visited exhibitions has been a display of gowns worn by the First Ladies of the United States. An unofficial title, "first lady" has been in popular use since the 1860s to refer to the president's official hostess who is usually, but not always, the president's wife.

Many people think of the first family as the United States' version of royalty who are expected to fulfill ambiguous and evolving ideals of how to act and look. New first ladies have often discovered that they will have to learn how to dress to belong in this national spotlight. If a first lady fails to achieve this elusive goal, she is vulnerable to the political consequences of media criticism; but when a first lady does succeed, she may popularize a fashion.

### Political Implications

While Americans want their first lady to look as if she represents an affluent and powerful country, citizens do not want her to look too regal—spending excessive amounts on high-fashion clothing. For example, in the early 1860s the southerner Mary Todd Lincoln was severely criticized for her extravagant fashions and entertainment as the nation dealt with the horrors of the Civil War. A hundred years later, Jacqueline Kennedy's love of expensive clothes, particularly French couture, became a political liability during the 1960 presidential campaign between her husband and Richard Nixon. To avoid these hazards, attractive Pat Nixon restrained herself from buying anything too special. The fur coats she purchased in the past did not support the public persona of a "good Republican woman in a cloth coat."

Some presidents' wives have only slightly refined their wardrobe for their public role. For example, in 1998, self-assured Barbara Bush had no intention of becoming more concerned with her appearance while first lady; but she came to appreciate her American designers, Arnold Scaasi and Bill Blass. They transformed her into a glamorous grandmother who felt pretty even as she endured treatments for Graves disease.

As the first president's wife to have been born after World War II, Hillary Rodham Clinton was part of a generation who paid more attention to their achievements than to their appearance. She eschewed the fash-

ionable trappings of traditional "well-bred" ladies and focused on her education and professional career. Mrs. Clinton was first criticized for this lack of attention to her appearance and then judged for all the "fine tuning" she attempted, particularly changes in hairstyles. When a first lady's appearance is continually criticized, it seems more likely that she is being attacked because she acts different rather than just because she looks different. Never was this truer than for Mrs. Clinton—a lawyer, a public servant, and a new kind of first lady.

### Fashion Popularizer

Although a successfully dressed first lady is not a fashion innovator, a favorite color—Mamie (Eisenhower) pink—or accessory—Barbara Bush's three-strand imitation pearl necklace—or even a single dress style could become more popular because of her well-publicized role in the White House. In 1993, Mrs. Clinton wore to her first official White House event a Donna Karan turtleneck, long-sleeved, long black dress with cutouts that bared her shoulders. This glamorous dress was not a new style; it had already been seen on celebrities such as Liza Minnelli and Candice Bergen. Nevertheless, within a week of Mrs. Clinton's stunning appearance, manufacturers copied it by the thousands for the mass market.

Dolley Madison and Jacqueline Kennedy were two first ladies who popularized more than a dress style. They each embodied a unique way of dressing that influenced women in their own time. In the early nineteenth century, Dolley Madison's love of French fashions and elegant furnishings encouraged conservative American women to more fully embrace the latest foreign fashions. The popularity of the lively Mrs. Madison blunted the effect of the critics who accused her of aristocratic behavior unsuitable for the first lady of a republic. In contrast, two months before the election in 1960, Jacqueline Kennedy was directed by her husband's advisers to stop buying French couture. Taking into account the best of French fashions, she crafted a simple, youthful, made-in-America glamour. She exemplified a new, and soon-to-become classic, American look.

### Collection and Exhibition

In the early twentieth century, the Smithsonian Institution, along with other museums presenting American history, celebrated the accomplishments of notable people, most of whom were important white men. Intended as a way to educate the public in the values of hard work and good citizenship, the focus was on traditional masculine achievements. As Edith Mayo, curator emeritus First Ladies Collection, reported in her 1996 publication, *The Smithsonian Book of the First Ladies*, a volunteer supporter of the Smithsonian, Mrs. Cassie Myers James "introduced the idea of women as historical role models by building a collection of clothing that showed 'the fashions of the women of the United States from colonial times . . . and their sphere in home life'" (p. 279).





**Smithsonian exhibit of First Ladies.** First Ladies often walk a fine line when choosing their dress, as the public wants them to look sophisticated and elegant, but not extravagantly so. © RICHARD T. NOWITZ. REPRODUCED BY PERMISSION.

The inspiration to acquire and exhibit dresses of the first ladies came about when a descendant of President James Monroe, Mrs. Rose Gouverneur Hoes, was invited to contribute to the collection. In 1912 the success of this effort was assured when Mrs. William Howard Taft, the current first lady, and descendants of five other presidents, promised gowns for the collection. By 1915 the display of dresses in rows of cases was called “Historical Costumes, Including those of the Mistresses of the White House.”

These collections and the exhibition were radical innovations. For the first time, women were made visible in the nation’s museum, creating a precedent for future collections about women. Over time, the Smithsonian’s presentation of the first ladies has changed. In the 1950s the dressed mannequins were reinstalled in elaborate room settings resembling public spaces in the White House during different periods. In March 1992 a new exhibition, “First Ladies: Political Role and Public Image” opened. In a break with tradition, the first ladies are reinterpreted as historical agents in their own right within the context of the American presidency and the history of women in America. The continued popularity of the Smithsonian’s First Ladies Hall demonstrates both the

American fascination with first ladies and the power of dress to evoke the personality and life experiences of the wearers.

See also **Blass, Bill; Celebrities; Fashion Icons.**

#### BIBLIOGRAPHY

Mayo, Edith, ed. *The Smithsonian Book of the First Ladies: Their Lives, Times, and Issues*. New York: Henry Holt, 1996.

*Claudia Kidwell*

**FLANNEL** Flannel is a light to heavyweight fabric woven as a plain or twill weave that originated in Wales. Some sources claim the name is derived from the Welsh word “gwalen,” which means literally a piece of clothing or material made of wool. Another possible etymological origin of the word is from the Old French “flaine,” which refers to a blanket or coverlet. Flannel is finished with napping to increase its insulating properties. After the fabric is woven, it is brushed so that the staple fiber ends are loosened from the weave to form a fuzzy surface.

Napping also contributes to the soft hand of the fabric. Flannel may be made from wool, cotton, synthetic fibers, or blends that incorporate a synthetic fiber with a natural fiber to add to the overall strength of the fabric and increase resistance to abrasion. Flannel-back satin refers to a type of silk satin that has spun yarns in the weft (crosswise yarn) and is brushed or napped on the back.

Cotton flannel is made with loosely spun filling yarns to ensure a dense nap. It may be napped on one or both sides. After the untreated fabric or greige goods are napped, the fabric is dyed or printed and finished again by brushing or being run through the napping machine a second time to restore the nap. Variations of cotton flannel include outing flannel, Canton flannel, dommet flannel, flannelette, and suede cloth, which is shorn after napping. Outing flannel, which is heavier than flannelette, is used for lightweight jackets, shirts, dresses, and upholstery. Flannelette is used for bedding and sleepwear.

Wool flannel may be made of either worsted or woolen yarns, the latter producing a denser nap. It is typically napped on one side only. Flannels made of woolen yarns are usually plain woven, and those made of worsted yarns are usually twill. Worsted flannel is lighter and firmer than woolen and will wear better. Pure wool flannel is a favorable fabric for tailoring because it shapes easily with the use of steam and heat. Wool flannels are used to make trousers, skirts, suits, and coats. French flannel is a variation of wool flannel that has a more fluid drape.

*See also* **Napping; Worsted.**

#### BIBLIOGRAPHY

- American Fabrics Encyclopedia of Textiles*. 2nd ed. Englewood Cliffs, N.J.: Prentice Hall, 1972.
- Gioello, Debbie Ann. *Profiling Fabrics: Properties, Performance and Construction Techniques*. New York: Fairchild Publishing, 1981.
- Humphries, Mary. *Fabric Glossary*. 3rd ed. Upper Saddle River, N.J.: Pearson Prentice Hall, 2004.
- Kadolph, Sara J., and Anna L. Langford. *Textiles*. 9th ed. Englewood Cliffs, N.J.: Prentice Hall, 2002.
- Linton, George E. *The Modern Textile and Apparel Dictionary*. 4th ed. Plinfield, N.J.: Textile Book Service, 1973.

*Marie Botkin*

**FLAPPERS** The flapper was an important figure in the popular culture of the 1920s and helped to define the new, modern woman of the twentieth century. She was the embodiment of the youthful exuberance of the jazz age. Although she defied many of society's taboos, she was also seen by many as the ideal young woman and was described by author F. Scott Fitzgerald as "lovely, expensive and about nineteen."

It is commonly assumed that the term "flapper" originated in the 1920s and refers to the fashion trend for un-

fastened rubber galoshes that "flapped" when walking, an attribution reinforced by the image of the free-wheeling flapper in popular culture. Despite this potent imagery, the word has its origins in sixteenth-century British slang. Deriving from the colloquial "flap," the word indicated a young female prostitute and likely referred to the awkward flapping of a young bird's wings when learning to fly. By the nineteenth century the term had lost most of its lewd connotations and instead was used to describe a flighty or hoydenish adolescent girl. In the years following World War I, the word was increasingly used to describe a fashionably dressed, impulsive young woman and by the 1920s, it was used to describe "modern" young women who broke traditional rules of both appearance and behavior.

The "fast living" ethos of the 1920s was widely perceived to be a direct consequence of World War I. During wartime, many young women experienced freedoms previously unheard of, such as taking jobs, shortening skirts, driving cars, and cutting their hair. Competition for male attention was paramount since the pool of eligible men had been depleted during the war, and this probably contributed to the flashier fashions and aggressive behavior of many young women. Outrageous behavior and dress was seen as an investment against spinsterhood or, at the very least, boredom.

#### The Flapper Image

The common perception of the flapper had as much to do with behavior as it did with appearance. Flappers displayed a carefree disregard for authority and morality. They drank heavily in defiance of Prohibition, smoked, embraced new shocking dances like the Charleston, the Shimmy, and the Black Bottom, used slang, drove fast, and freely took lovers and jobs. Posture and motion were important elements of the flapper persona. The fast, jerky motions characterized by these popular dances emphasized bare arms, backs, and legs. The posture of the flapper was an affected "debutante slouch," often with hand on hip. This limp, listless pose was not possible on a traditionally corseted body and was meant to imply the aftereffects of the previous night's debauchery.

Accordingly, flapper styles blatantly disregarded established fashions in exchange for the new and daring. Popular styles of the 1920s focused on the display of the slim, youthful body through the use of short skirts and dropped waists. Gabrielle "Coco" Chanel and Jean Patou were particularly known for this youthful, sporty style. The flapper took this fashionable ideal to the extreme and wore the shortest skirts possible, low cloches, and negligible underwear. Evening dresses were sleeveless, flashy, and frequently featured slit skirts meant to enable active dancing. She bobbed her hair, wore obvious makeup, and sunbathed in skimpy, one-piece bathing suits.

A common element of the flapper style was the tendency to misuse clothing and accessories—a way of thumbing noses at high fashion and polite society. Ex-

amples of this phenomenon were the rolling of stockings below the knees, the wearing of unhooked rubber galoshes that “flapped” when walking, evening shoes worn with daywear, and occasionally even the natural waist worn in defiance of the dictates of high fashion. Flappers were also rumored to rouge their knees, and this is a part of the greater emphasis on legs crucial to the flapper persona. Besides the previously mentioned galoshes and rolled stockings, flappers were associated with elaborate garters and anklets. A daring minority rejected stockings altogether when the weather was warm, but many opted for stockings in fashionable “suntan” shades. Accessories that flaunted outrageous behavior, like the jeweled cigarette holder and ornate compact, were also popular.

### The Rise and Fall of the Flapper

The creation of the flapper image is largely credited to the writings of F. Scott Fitzgerald and the drawings of John Held Jr., which frequently featured skinny, stylized flappers in comical situations. Fitzgerald’s writings focused on the fast pace of modern life, but when he was given the credit for popularizing the movement, he responded, “I was the spark that lit up Flaming Youth and Colleen Moore was the torch. What little things we are to have caused that trouble.”

Fitzgerald shrewdly understood the power of the motion picture to spread the flapper image to a mass audience. Colleen Moore, Joan Crawford, Anita Page, and Clara Bow were some of the many actresses who specialized in flapper roles during this period. The flapper had been a popular screen type since the 1910s, and by the mid-1920s, films featured titles like *Flapper Fever*, *The Painted Flapper*, *Flapper Wives*, *The Perfect Flapper*, and *The Flapper and the Cowboy*.

Although viewers were unlikely to adopt the fast living and flamboyant dress seen on screen, it is quite likely that they incorporated elements into their lives. The 1928 film *Our Dancing Daughters*, which starred Joan Crawford and Anita Page, was particularly influential. The film was mentioned repeatedly in the Payne Fund Studies commissioned to determine the effects of film on the youth of the United States. One respondent claimed that after seeing *Our Dancing Daughters*, “I wanted a dress exactly like one she had worn in a certain scene. It was a very ‘flapper’ type of dress, and I don’t usually go in for that sort of thing” (Massey, p. 30).

As early as 1922, it was suggested that the term “flapper” be divided into three levels: the semi-flapper, the flapper, the superflapper. By the end of the decade, most young women could easily be classed as a semi-flapper since flapper styles and behaviors were gradually being adopted into mainstream life. Bobbed hair, lipstick, and short skirts no longer were the sign of a flapper, just that of a modern fashionable woman.

With the stock market crash of 1929, the frivolity and excess characterized by the flapper and the jazz age



**Joan Crawford models a flapper dress.** The emphasis of flapper fashion was on the feminine figure, and garments such as this showcased a woman’s bare arms, slim waist, and legs. © BETTMANN/CORBIS. REPRODUCED BY PERMISSION.

were replaced with frugality and a return to a more traditional view of feminine behavior and dress. Although the stock market crash signaled the flapper’s demise, she remains a potent symbol of flaming youth.

See also **Chanel, Gabrielle (Coco); Patou, Jean; Subcultures.**

#### BIBLIOGRAPHY

- Evans, Mike, ed. *Decades of Beauty*. New York: Reed Consumer Books Limited, 1998.
- Hall, Lee. *Common Threads: A Parade of American Clothing*. Boston: Little, Brown and Company, 1992.
- Hatton, Jackie. “Flappers” In *St. James Encyclopedia of Popular Culture* Vol. 2: E–J. Edited by Tom Pendergast and Sara Pendergast. Detroit: St. James Press, 2000.
- Latham, Angela J. *Posing a Threat: Flappers, Chorus Girls, and Other Brazen Performers of the American 1920s*. Hanover, Conn.: Wesleyan University Press, 2000.
- Massey, Anne. *Hollywood Beyond the Screen: Design and Material Culture*. Oxford: Berg, 2000.
- Rosen, Marjorie. *Popcorn Venus: Women, Movies and the American Dream*. New York: Avon Books, 1974.

Clare Sauro



**FLIPFLOPS.** See **Sandals.**

**FLOCKING** Flocking is a method to apply very short (1/10" to 1/4") fibers called flock to a substrate, such as fabric, foam, or film, coated with an adhesive. Flocking is an inexpensive method of producing an imitation extra-yarn fabric, flocked in a design, or a pile-like fabric where the flock has an overall pattern. Examples of end use of flocked fabrics for home furnishings include carpeting, upholstery fabrics, blankets, bedspreads, wall coverings, and window coverings. For clothing, flocked fabrics are used for shoes, hats, and apparel fabrics. Industrial uses include automotive fabrics, conveyor belts, air filters, books, and toys.

The flock is applied to the fabric using a mechanical or electrostatic process. Depending on the process and fibers used, the effect may be a velvety or suede-like appearance.

Natural or synthetic fibers such as cotton, rayon, nylon, and polyester can be used depending on the particular end use. There is an advantage to using first-quality filament synthetic materials, because the flock can be cut square and in uniform lengths. Cotton is the least expensive and the softest but does not have good abrasion resistance. Rayon has the advantage of being low cost and uniform, but also has low abrasion resistance. Nylon has the best abrasion resistance. Present-day adhesives, such as aqueous acrylic, polyester, and nylon, have excellent bond and usually have the same flexibility and wear resistance as the substrate. The high-quality adhesives have excellent fastness to laundering, dry cleaning, or both, but it is important that testing is conducted to ensure that the cleaning method listed on the label is accurate.

### The Processes

After the flock is cut, it is then cleaned. The fibers and the substrate are dyed if they are to be colored. The adhesive is applied to the substrate in the desired design. The flock is then prepared depending on what method will be used to apply the flock to the adhesive. In the mechanical process, a simpler and less-expensive means of flocking, the fibers are placed in a hopper and sifted onto the substrate where beater bars vibrate the flock. The vibration helps the fibers become erect on the adhesive. The fibers randomly adhere to the substrate at different depths forming an irregular surface. Shedding occurs because not all the fibers adhere to the adhesive.

In the electrostatic process the fibers are chemically treated to allow the fibers to receive an electrical charge. The moisture content is specified. Again the flock fibers are placed in a hopper where they are given an electric charge. A grounded electrode plate under the substrate orients the fibers in an upright position when they imbed into the adhesive. Electrostatic flocking is more expensive and slower, but the flock is more uniform and denser.

It is also possible to flock both sides of the fabric. Although there is a difference in the two processes, most consumers are unable to tell what method was used on the flocked fabric.

See also **Fibers; Yarns.**

### BIBLIOGRAPHY

- Carty, Peter, and Michael S. Byrne. *The Chemical and Mechanical Finishing of Textile Materials*. 2nd ed. Newcastle upon Tyne: Newcastle upon Tyne Polytechnic Products, 1987.
- Slade, Philip E. *Handbook of Fiber Finish Technology*. New York: Marcel Dekker, 1998.

*Robyne Williams*

**FLÜGEL, J. C.** John Carl Flügel (1874–1955) was an English academic psychologist, a prominent member of the British Psychoanalytical Society, and a leading figure in the movement for liberal social reform between the two world wars (1918–1939). A member of the Men's Dress Reform Party, in 1930 he published *The Psychology of Clothes*, the first Freudian-inspired analysis of dress and fashion. In this work he advances the idea that clothing is a "compromise-formation" that mediates between the desire of children to exhibit their naked bodies and the later social prohibition that the body be covered for the sake of modesty. For Flügel the story of clothing is the story of the relative strength of these two forces.

### Freud, Flügel, and Politics

Flügel makes little use of Freud's ideas of clothing as either fetish objects or as sexual symbols in dreams. Central to his analysis of clothing is the sociopolitical interpretation he gives to Freud's model of the human psyche. Freud argues for a three-part division of the mind into id, superego, and ego. The id is the dimension of primitive instinct and the ultimate propelling force of the organism. The superego is an equally primitive inhibitory mechanism that operates as a crude controller of the desires of the id. The ego has the difficult task of establishing a compromise between the demands of the id, the superego, and the outside world so that the individual can exist as a functioning entity. Flügel assigns a general political value to each of these dimensions of the mind. He relates his program of reform to lessening of the power of an overbearing superego, which he regards as the driving force of authoritarian conservatism. As he comments, "The troubles that we experience in adjusting ourselves to civilized social life seem to be due, not merely, as earlier moralists had supposed, to the strength of our a-social instincts [the id], but also, in no inconsiderable degree to the power of the primitive moral factors embodied in the superego" (Flügel 1934, p. 296).

Clothing, for Flügel, comes into being so as to reconcile the demands that these opposing forces place upon the human body and psyche. Dress, therefore, is a prime

area of dispute between political liberals and conservatives over what sort, and how much, clothing is appropriate in civilized society.

### The Psychology of Clothes

Flügel's theory of clothing attempts to answer two questions. First, why do human beings wear clothes at all? Second, why do the ways in which human beings dress vary so greatly?

The conventional answer given by European thinkers to the first question proposed the existence of three "fundamental motives" out of which clothing was thought to have arisen—bodily protection, modesty, and decoration. Flügel concentrates on the motives of modesty and decoration. Using a version of Freud's model of how the child becomes a socialized adult, he argues that we are born in a condition of narcissistic self-love. The consequence is a "tendency to admire one's own body and display it to others, so that others can share in the admiration. It finds natural expression in the showing off of the naked body and in the demonstration of its powers, and can be observed in many children" (Flügel 1930, p. 86).

This state of idyllic infantile nudity ceases with the arrival of the somatic prohibitions associated with the forces of modesty. The infant relinquishes its pleasurable self-absorption. The body is covered, and shame is triggered when too much of it is inappropriately revealed. However, neither of these tendencies is ever able fully to cancel out the other. As Flügel observes:

The exhibitionistic instinct originally relates to the naked body, but in the course of individual development it inevitably (in civilised races) becomes displaced, to a greater or lesser extent onto clothes. Clothes are, however, exquisitely ambivalent, in as much as they both cover the body and thus subserve the inhibiting tendencies that we call "modesty," and at the same time afford a new and highly efficient means of gratifying exhibitionism on a new level.

(Flügel 1932, p. 120)

Clothes simultaneously both hide and draw attention to the body.

### Variations of Dress

Flügel realizes that while all humans are dressed, the manner in which this is achieved varies greatly with time and place. His explanation of this is the following:

to understand the motives that lead to different kinds of clothing, to changes in our clothing and to the changes in our whole attitude towards clothes, we shall have to be constantly on the look out for changes in the manifestations of these two fundamental conflicting tendencies, the one proudly to exhibit the body, the other modestly to hide it. (Flügel 1928)

The most striking of these dress variations, certainly to Flügel and his contemporaries, are those between men and women. Indeed, contemporary European clothing presented Flügel with an added complication, in that it

seemed to run against the "normal" situation encountered in nature as well as the evidence of "primitive peoples." There the man "is more ornamental than the female" and almost always the most "adventurous and decorative" in his appearance. In explaining this anomaly, Flügel argues that a profound reorganization of masculinity took place during the political and economic revolutions of the late eighteenth and nineteenth centuries. The tendency to modesty increased at the expense of "male sartorial decorativeness," and the result was a set of simplified garments, less colorful and with a greater degree of uniformity than had existed in previous historical epochs. Flügel named this dramatic shift "The Great Masculine Renunciation" (Flügel 1930, p. 110ff). Against this, he greatly approved of the development taken by European female dress. Beginning with the extremely modest clothing styles of the Middle Ages, female dress had gradually reformed itself. Flügel claimed that female clothing now exhibited a more rational integration of the antagonistic forces operating on dress than was the case in male dress. Indeed, it was his respect for what he saw as the positive mental benefits provided by contemporary forms of female dress that lead him to advocate the reform of men's clothing.

### The Nude Future

Near the end of his book *The Psychology of Clothes*, Flügel speculates about a future in which clothing could become obsolete. He argues that, the three main reasons for wearing clothes—bodily protection, modesty, and adornment—will all be surpassed as humans evolve a more "developed" and "rational" way of life. The need for protection will diminish as the control of the environment—for example, by the heating engineer—increases (Flügel 1930, p. 235). The urge to cover our bodies out of a sense of modesty will evaporate once we understand how irrational our fears of nakedness are. Finally, decorative modification and alteration of our bodies would cease as we become reconciled more and more to the natural human form (Flügel 1930, p. 235). As a species we will achieve a "complete reconciliation with the body [which] would mean that the aesthetic variations, emendations, and aggrandizements of the body . . . produced by clothes would no longer felt [to be] necessary" (Flügel 1930, p. 235). Clothing would just fade away.

See also **Fashion, Theories of; Nudity.**

### BIBLIOGRAPHY

- Burman, B. "Better and Brighter Clothes: The Men's Dress Reform Party, 1929–1940." *Journal of Design History* 8, no. 4 (1995): 275–290. A fascinating account of the men's dress reform movement, in which Flügel was an important participant.
- Carter, Michael. "J. C. Flügel and the Nude Future." In *Fashion Classics from Carlyle to Barthes*. Oxford and New York: Berg, 2003. An examination of Flügel's ideas on clothing, particularly as they pertain to his liberal social beliefs.

Flügel, John C. Unpublished transcript of a talk given by Flügel on BBC Radio, 26 June 1928.

———. *The Psychology of Clothes*. London: Hogarth Press, 1930.

———. *An Introduction to Psycho-Analysis*. London: Victor Gollancz, 1932.

———. "A Psychology for Progressives—How Can They Become Effective?" In *Manifesto: Being the Book of the Federation of Progressive Societies and Individuals*. Edited by C. E. M. Joad. London: George Allen and Unwin, 1934.

Michael Carter

**FOGARTY, ANNE** Anne Fogarty is best remembered for designing quintessential 1950s fashions for young women that emphasized femininity and for espousing the concept of "wife-dressing," the title of her 1959 book. Born Anne Whitney in Pittsburgh, Pennsylvania, on 2 February 1919, Fogarty moved to New York City in her early twenties to pursue acting. While working as a fitting model for the dress manufacturer Harvey Berin, she decided to become a fashion designer. In the late 1940s and 1950s, she designed clothing for the teenage and junior markets, creating her signature "paper doll" dress while working at Youth Guild in 1948, for which she won



**Model in Anne Fogarty design.** Fogarty's fashions focused on femininity and the role of the woman in domestic life. AP/WIDE WORLD PHOTOS. REPRODUCED BY PERMISSION.

the Coty award in 1951 and the Neiman-Marcus Award in 1952. In 1954, while working for Margot Dresses, she introduced her "tea cozy" dress, a variation on the paper doll silhouette.

With its tight bodice, wasp waist, and full, ballet-length skirt supported by layers of stiffened petticoats, the paper doll dress was a simplified and inexpensive adaptation of Christian Dior's 1947 "New Look." Its silhouette was nostalgically romantic and playful and reflected Fogarty's first principle of wife-dressing: "Complete Femininity—the selection of clothes as an *adornment*, not as a mere covering" (p. 10). In her book, *Wife-Dressing: The Fine Art of Being a Well-Dressed Wife*, Fogarty instructed wives to wear their corsets and never to let their husbands see them in pin curls or dungarees. Wife dressing was about dressing to please husbands and aiding their social advancement; for Fogarty, a wife was an appendage and her marital roles were of foremost importance (Fogarty herself was married three times). The book also contains advice for husbands—"If you adore her, adorn her. There lies the essence of a happy marriage" (p. 9) and tips on pruning one's wardrobe, multipurpose dressing for day and evening, and how to be disciplined and discerning in creating one's own look—not unlike tips found in the pages of 1950s fashion magazines.

The ideas expressed in Fogarty's book reflect and reinforce the centrality of women's domestic lives just after World War II. Women were to be in character and properly outfitted, maintaining the feminine mystique as wife and mother. An emphasis on femininity, exemplified in fashions and accessories that exaggerated the female figure, emerged in the late 1940s and 1950s as many women returned to the home front after having worked during the war. Even successful career women like Fogarty maintained the centrality of home life.

As social norms and fashions changed in the following decades, Fogarty expanded as a designer. By the end of the 1950s, she was the exclusive designer for Saks Fifth Avenue, designing more casual, versatile styles. In 1962 she opened her own business, Anne Fogarty, Inc., which ran successfully for eight years. Throughout the 1960s and 1970s she experimented with different silhouettes (her favorite being the Empire) and targeted a more mature audience. After closing her business in 1970, she did freelance designing until her death on 15 January 1980.

Anne Fogarty was, at least in part, a woman and designer of her time. The fashions for which she is best remembered reflect the prevailing ethos of postwar femininity. Yet she was also part of a generation of American designers who tapped into the burgeoning youth culture of the 1950s and 1960s and whose fashions speak to a versatility and youthfulness that are part of a distinctly American vernacular of fashion.

See also **Dior, Christian; New Look; Paper Dresses.**



**BIBLIOGRAPHY**

- Fogarty, Anne. *Wife-Dressing: The Fine Art of Being a Well-Dressed Wife*. New York: J. Messner, 1959.
- Milbank, Caroline Rennolds. *New York Fashion: The Evolution of American Style*. New York: Harry N. Abrams, 1989.
- Steele, Valerie. *Women of Fashion: Twentieth Century Designers*. New York: Rizzoli International, 1991.
- Williams, Beryl. *Young Faces in Fashion*. Philadelphia: J. B. Lippincott, 1956.

*Tiffany Webber-Hanchett*

**FOLK DRESS, EASTERN EUROPE** Folk dress in eastern Europe distinguished shepherds and peasants from fashion-following townspeople and landowners. In regions where peoples of different ethnic origins coexisted, folk dress could also function as ethnic dress. The general characteristics of eastern European folk dress resembled those of western Europe. However, historical and cultural influences created some remarkable folk costumes and customs.

**Historical Overview**

Eastern Europe has experienced centuries of change as a result of shifting political boundaries. Tribal groups inhabited many northern and central regions until Germanic crusaders arrived during the Middle Ages. Thereafter, a landowning class developed that oversaw agricultural production by peasant-serfs. Ottoman Turkey ruled much of southeastern Europe, stretching as far north as Hungary. Russia, poised on the edge of Europe, melded ideas from both east and west. During the tumultuous twentieth century, eastern European countries became part of the Russian Soviet Federative Socialist Republic. The breakup of the Soviet Union in 1991 brought a period of ethnic conflict, still not fully resolved in the early 2000s.

For the study of folk dress, divisions are cultural rather than political. Distinctive styles for peasants appeared as early as the sixteenth century. Influences came from both Europe's fashion capitals and the Ottoman Turks. Several older tendencies already in clothing practices solidified. While some elements came and went, others continued in use and became long-standing components of regional folk dress. In the eastern- and southernmost regions, the wearing of folk dress lasted until the middle of the twentieth century.

As in western Europe, Romanticism and nationalism encouraged the early collection of folk material. Ethnographers carefully recorded facts about the costumes that they collected, including the many local names for the various components. State-run museums harbor rich collections of folk costumes and related textiles. Much of the literature published during Soviet domination is in Russian, although some texts are translated into two or three languages. With the breakup of the Soviet Union,



**Russian peasant girls.** Peasant clothing, which represented close ties to the land, remained popular in several eastern European countries until the end of the nineteenth century. © SCHEUFLER COLLECTION/CORBIS. REPRODUCED BY PERMISSION.

folk dress gained new status as a symbol of independent nationhood. The many active folk-dance troupes of eastern Europe and abroad maintain a lively interest in creating accurate replicas of costumes.

**Baltic Countries**

The three independent states that border the Baltic Sea—Estonia, Latvia, and Lithuania—display great affection for their folk dress. Ethnic celebrations, at which singing of folk songs is an important activity, provide opportunities to wear folk costumes.

Women's folk costumes consisted of skirts, white blouses, and vests; shawls with decorative borders; and headgear to distinguish young unmarried women from matrons. The latter wore crowns, coronets, or floral wreaths to signal their availability, while married women covered their hair with caps or cloths. Brooches and pins made with Baltic amber fastened blouses and shawls. Men's costumes included a shirt, breeches, coat, and hat. Men often secured their stockings with narrow sashes.

Baltic women excelled in weaving complex patterns for belts, sashes, and trims. The following Lithuanian folk song tells of dowry preparation:

Weave, dear mother, the finest linen cloth  
While I, still young, weave sashes.  
A young man from a distant land  
Is eager for my hand.



**Albanian women in native dress.** Heavy wool fabric is commonly used in the Balkans, as are linen, hemp, and cotton. Jewelry and headdresses made from metal coins are also prevalent. © LUCIEN AIGNER/CORBIS. REPRODUCED BY PERMISSION.

Women also knitted many pairs of patterned mittens and gloves. The motifs in the weaving and knitting are considered mythological signs by some authorities. Archaeological evidence from the eighth to the thirteenth centuries reveals that some of these costume features predate the arrival of Teutonic crusaders, and thus Christianity.

Some controversy exists about which are the “real” national costumes. In each of the Baltic countries, folk dress based on regional divisions went through several iterations. While some groups look to the ethnographic material collected in the nineteenth and early twentieth centuries, others propose going further back in time to the dress worn prior to foreign occupation. Folk dress in the Baltics continues to evolve.

### Russia, Belarus, and Ukraine

Western ideas about dress came to Russia, Belarus, and Ukraine rather late in history. In 1700, Peter the Great of Russia forced adoption of European fashions through imperial decree in an attempt to bring refinement to his court. Yet peasants continued to wear folk dress until the end of the nineteenth century. The late arrival of Chris-

tianity to this area, combined with the peasants’ connection to the land, preserved ancient agricultural beliefs evident in both style and embellishment of folk dress.

In both Russia and Ukraine, a woman wore a woolen back-apron over her chemise. Called a *plákhta* or *panjóva*, it signaled marital status. Another archaic dress form is a shirt with ultra-long sleeves. Worn by young girls during ritual dances, the fluttering sleeves helped them simulate bird maidens known as *vily* or *rusálki*. Embroidery motifs also link to pre-Christian beliefs. Predominantly geometric, the motifs include known fertility and protection symbols. One example is the hooked lozenge, said to represent a fertile field. The use of the primordial colors of red and black (blood and earth) further connect folk dress with pre-Christian religious practices.

Some dress traditions, such as the economical use of cloth, date from the Middle Ages. Lengths of wool and linen were joined with minimal piecing, not cut up for Renaissance-influenced tailored clothing. Both men and women wore linen shirts as the first layer of clothing. Men wore two shirts—the top one of better fabric—over trousers tucked into boots. The shirts were girdled at the

waist. In some areas of Russia, women wore a *sarafan*, a long overdress resembling a jumper. As elsewhere, young girls wore crowns, or diadems, while married women covered their hair. Caftans, capes, and furs provided warmth for both sexes during the cold winter months.

### Central Europe

The central European countries have a long, rich history of folk dress. The middle and upper ranks sometimes wore elaborate versions of what could be termed a national style in the seventeenth and eighteenth centuries. Such styles were influenced by European fashions as well as by Ottoman dress. Other components of folk dress in these regions have antecedents that stretch back hundreds, if not thousands, of years.

One such garment is the Hungarian *szűr*, a man's hooded or collared mantle with hanging sleeves. Scholars believed that it developed from the first sleeved coat—the Persian *kandys*—in the sixth century B.C.E. The Magyars, forerunners of the Hungarians, brought it with them to the central European plains in the ninth century where it developed and flourished as a man's outer garment. Made from coarse fulled wool in either black or white, the decorated *szűr* remained popular with peasants and herdsman into the early twentieth century. A related garment is the *suba*, a shaggy woolen cape favored by shepherds.

In Hungary, men's folk dress is just as ornamental as women's. Men wore jackets (*dolman*), overcoats (*mente*), fitted pants, and knee-high boots decorated with oriental patterns in embroidery or braid. Even the boot tops could be decorated. Women's dress, which depended heavily on Western fashion, featured Ottoman-influenced tulips and carnations. Frog closures are a design feature of Hungarian coats and jackets for both sexes. Hungarian dress was influential beyond its borders, reaching north to Poland and west to Austria and Switzerland.

Folk dress in the Czech Republic and Slovakia, called *kroje*, had many local variations. The most distinctive women's costumes are characterized by blouses with large extended sleeves, short full skirts, and prominent head-dresses. Lace, cutwork, and embroidery embellished both men's and women's folk dress. During the eighteenth century, the monarchy was charmed by peasant costumes and orchestrated court appearances of peasants in their local dress. The real flowering of folk dress occurred in the late eighteenth and early nineteenth centuries and lasted until 1848 when serfdom was abolished. Some of the older ritualistic uses of folk dress prevailed, specifically the capping of the bride in marriage ceremonies and the isolation of new mothers behind large linen shawls.

In Romania and Moldavia, embroidered linen blouses are among the most treasured components of folk dress. Two types exist based on cut. The first, which dates to the adoption of horizontal looms, has a T-shape and



### FUNCTIONS OF FOLK DRESS

In 1971, Petr Bogatyrev published his influential study *The Functions of Folk Costume in Moravian Slovakia*. A proponent of structuralism, Bogatyrev argued that peasant clothing may be interpreted as a language that communicates a number of functions. These functions express attitudes within the community regarding social, aesthetic, moral, and nationalistic ideals. His observations regarding the wearing of folk dress, some of which are summarized below, apply to all of eastern Europe.

- Folk dress signifies a special day, such as Sunday, holiday, or ceremonial day. Clothing for brides and grooms are among the most elaborate.
- Folk dress indicates the occupation of the wearer (for example, shepherd).
- Folk dress distinguishes wealth and social status, typically through the number and quality of clothing items.
- Components of folk dress have a “magical” function. For example, the ritual marriage cap placed on a new bride brought fertility and good fortune.
- Folk dress signifies regional and national affiliation.
- Folk dress may indicate religious affiliation.
- Age and marital status is communicated by folk dress. Contradictory situations in peasant society, such as single motherhood, are visible in a woman's appearance.
- Folk dress has approved aesthetic qualities that attract available members of the opposite sex.

no shoulder seams. The second type is gathered at the neck with a drawstring and has full sleeves. Its origins are in Renaissance shirts. The embroidery of these blouses is remarkable—sleeves are covered in geometric motifs of Slavic origin. Romanians wore a variety of outer woolen garments similar to those found in the Balkans: pieced trousers, vests, and coats.

Poland's folk dress is more like that of western Europe: women's outfits consist of white blouses, fitted vests, and full skirts, while men's ensembles include breeches, coats, and hats. Folk-dress traditions were formed in the early seventeenth century, appropriating the braiding and cording so popular among the Hungarians. Older folk beliefs about the allure of women's hair kept matron's heads covered with a variety of cloths and caps.





**Albanian boys.** White, full-sleeved shirts and felt hats such as those seen here are major components of the Albanian traditional dress for males, which is influenced heavily by Turkish fashions. © SETBOUN/CORBIS. REPRODUCED BY PERMISSION.

### Balkan Countries

The Balkan countries include Albania, Bosnia-Herzegovina, Croatia, Slovenia, Serbia, Montenegro, Macedonia, and Bulgaria. The former Yugoslavia is in the Balkan region. Mainland Greece belongs geographically to the Balkans, but the country was never part of Europe's Soviet bloc.

Competing ethnic and religious groups, whose clothing differs from one another in form or decoration, inhabit specific regions in the Balkans. Turkish influence is strong, as these countries were once part of the Ottoman Empire. Women of the Muslim faith wore Turkish-style trousers while Christian women wore ankle-length chemises. Fez caps identified Muslim males. Embroidery in curvilinear Islamic designs is seen on costumes in all the countries once ruled by the Turks. This work was done by professionals with couched threads of gold or black silk on fine wool or velvet.

Heavy woolen fabric known as *saya* or *tsocha* was common to both male and female costumes. Women spun the wool, which they collected from their flocks, then wove on simple two-harness looms. Sometimes they

dyed the fabric black or dark blue; other times it was left white. Then they sent the fabric to water mills near mountain streams for fulling. This process made the wool dense and thick, suitable for village tailors to cut and sew coats, trousers, vests, and jackets.

The women also wove linen, hemp, or cotton for men's shirts, women's chemises, and head cloths. They sewed them with a minimum of cutting and seaming so that no cloth was wasted, then embroidered them with silk or wool threads in dense geometric motifs, some of which are known fertility symbols. In some districts long red or black fringes protected brides and newly married women from the "evil eye," a malevolent force feared throughout the region. In western Macedonia, these fringes can be found on aprons, sleeves, jackets, belts, and headscarves. In her book *Women's Work*, Elizabeth Barber proposes that fringes on folk dress signaled a woman's availability for marriage just as they did in Neolithic times. Customs such as those in parts of Albania—where a woman who is divorced must cut the fringes from her garments to signify her changed social status—confirm this assumption.

A garment that interests dress historians is the Albanian *xhubleta*, a bell-shaped skirt constructed from narrow bands of homespun cloth that resembles Minoan women's dress. Another is the white *foustanella* costume of the Albanian resistance fighters, one of the few skirts worn by men in Europe. More often, men wore baggy pants cut in the Turkish fashion.

Another component common across the Balkan countries is the use of metal coins made into necklaces and headpieces. Large ornamental belt buckles are used for women's festival dress. Commercially printed yellow or white kerchiefs replaced the older white head cloths in recent years.

See also **Ethnic Dress; Folk Dress, Western Europe; Folklore Look.**

#### BIBLIOGRAPHY

- Barber, Elizabeth Wayland. *Women's Work: The First 20,000 Years: Women, Cloth, and Society in Early Times*. New York: W. W. Norton and Company, 1994.
- Bogatyrev, Petr. *The Functions of Folk Costume in Moravian Slovakia*. The Hague, Netherlands: Mouton, 1971.
- Burnham, Dorothy. *Cut My Cote*. Toronto: Royal Ontario Museum, 1973.
- Földi-Dózsa, Katalin. "How the Hungarian National Costume Evolved." In *The Imperial Style: Fashions of the Hapsburg Era*. New York: Metropolitan Museum of Art, 1980.
- Gervers-Molnár, Veronika. *The Hungarian Szür: An Archaic Mantle of Eurasian Origins*. Toronto: Royal Ontario Museum, 1973.
- Kennett, Frances. *Ethnic Dress*. New York: Facts On File, 1995.
- Paine, Sheila. *Embroidered Textiles: Traditional Patterns from Five Continents*. New York: Rizzoli International, 1990.
- Petrescu, Paul, and Elena Secosan. *Romanian Folk Costume*. Bucharest, Romania: Meridiane Publishing House, 1985.
- Snowden, James. *Folk Dress of Europe*. New York: Mayflower Books, 1979.
- Tilke, Max. *Costume Patterns and Designs*. New York: Hastings House, 1974.
- Turnau, Irena. "The Main Centres of National Fashion in Eastern Europe from the Sixteenth to the Eighteenth Centuries." *Textile History* 22, no. 1 (1991): 47–66.
- Welters, Linda, ed. *Folk Dress in Europe and Anatolia: Beliefs About Protection and Fertility*. Oxford and New York: Berg, 1999.

Linda M. Welters

**FOLK DRESS, WESTERN EUROPE** Folk dress in Western Europe refers to the clothing of rural populations engaged in farming, fishing, or herding. Various terms—peasant, rural, or regional dress, it may also be considered ethnic dress in regions with more than one ethnic group. In all cases, folk dress identified people with a place.



**Swedish couple in wedding finery.** Swedes, like all Scandinavians, still honor their country's traditional folk dress, donning it frequently for festivals and special occasions. © BETTMANN/CORBIS. REPRODUCED BY PERMISSION.

#### Historical Overview

From the fourteenth to the eighteenth centuries, the dress of rural dwellers reflected the fashionable styles worn by those from the middle and upper ranks of society, albeit in simplified form. In many parts of Europe, sumptuary laws limited decoration and restricted use of materials so that peasants would easily be distinguished from those of higher social standing. The elimination of sumptuary laws, combined with land reforms, brought about a true flowering of folk dress in some, but not all, Western European countries in the late eighteenth and early nineteenth centuries.

Around the same time, political changes in Europe spawned nationalist movements in many countries. Early ethnologists began systematically collecting songs, legends, myths, and examples of regional dress to bolster the argument for the existence of a national character in the "folk." The romanticism of the era contributed to the invention of traditions not based in historical fact.

#### British Isles

The concept of invented traditions fits easily with the so-called folk dress of Scotland, Wales, and Ireland. Scotland is known for the man's kilt made from clan tartans. Historically, the Celts in Ireland and Scotland wore shirts and plaid mantles, which they arranged on their bodies in various ways. Sometime after 1727, Thomas Rawlinson, an Englishman living in Scotland, separated the plaid



### GREEK CUSTOMS

Katerina Stamou, born in 1892 in the Greek village of Peania, spoke about the wearing of folk dress in her youth, underscoring the importance of signifying marital status through appearance: "The newly married ones wore their jewelry for about a week after the wedding to show it off. They went to pick olives with all that jewelry on. They held the *kordoni* [necklace of many chains with coins attached] with one hand and picked olives with the other. Now we laugh about these things, but then that's how things were." (Interview with Katerina Stamou, Peania, Attica, Greece. 29 June 1983)

into the pleated kilt, or *philabeg*, and shoulder wrap. It became so popular that the English banned it after the rebellion of 1745, which served to strengthen its association with Scottish culture. After 1780, the mythology surrounding the kilt expanded to include the assignment of certain "setts," or plaid patterns, to specific clans.

Wales and Ireland offer more recent examples of invented traditions. As Welsh language and culture faded in the early nineteenth century, intellectuals promoted the preservation of customs and traditions. This extended to dress. In 1843, Lady Llanover invented a Welsh "national" dress loosely based on rural clothing of the 1780s: short gown, petticoat, and cloak of checked or striped wool worn with a tall beaver hat. In actuality, no one had ever worn that type of hat. A similar situation occurred in Ireland in the late nineteenth century when cultural leaders proposed a tunic and mantle combination inspired by the "ancient" dress of *brat* and *léine*. It became more Irish by adding Celtic embroideries.

England did not suffer the same crisis of identity as did Scotland, Wales, and Ireland; thus it did not have a folk dress. Certain occupational dress styles, such as the farmer's smock, were worn over breeches or trousers in rural areas.

### Scandinavia

The Scandinavian countries of Norway, Sweden, and Finland have strongly developed folk-dress traditions encouraged by the Romantic revival. Denmark's folk dress is not so well known, because the Danes did not systematically collect folk material in the nineteenth century as did the Swedes and Norwegians. Today, all of the Scandinavian countries actively preserve their folk dress. In America, descendants of Swedish and Norwegian émigrés don folk dress for festive attire.

In Sweden, each local parish has its own costume, which is still worn as festival dress. The authors of *Folk Costumes of Sweden: A Living Tradition* identified over 400 local costumes in use in the 1970s. While the parish costumes of some provinces such as Skåne, Dalarna, and Hälsingland have a long history, others are "reconstructed" based on old costume material in museums. Local costumes are seen as an expression of identification with one's home community. Some of the jackets have features dating to c. 1600, such as shoulder wings and pickadils.

Norway was under Swedish rule until 1905. The country's mountains and fjords promoted the development of independent communities organized around church parishes, each of which had distinctive sartorial customs. Sunday and festival dress was decorative while everyday clothing was quite plain. During the nationalist movement of the late nineteenth century, the folk dress of the Hardanger region came to symbolize Norway. It consisted of a long skirt, embroidered vest, and cut-work linen blouse in the heraldic colors of black, red, and white. Hardanger brides wore elaborate crowns, which they exchanged for marital caps during the wedding ceremony. Around 1900, the bunad movement promoted the wearing of other regional costumes for folk festivals, thereby expanding the Norwegian folk-dress repertoire.

Lapland, an area north of the Arctic Circle, is an ethnic area rather than a political entity. Its people, known as the Saami, are reindeer herders who roam across northern Norway, Sweden, and Finland into Russia. Not surprisingly, their clothing is made from reindeer skins and the fur of the Arctic hare. The colorful dress of the Saami, still worn for festive occasions, consists of a wool tunic worn over trousers and ear-protecting caps. Curled boots made from reindeer hide and stuffed with straw keep feet warm during the cold winters. The dominant colors are rich blue accented with red. Braids, tassels, and pom-poms in red, green, and yellow further enliven this unique costume.

Common to all Scandinavian countries is the wearing of silver brooches and pins, believed to ward off evil. The shiny metal protected people of all ages from legendary supernatural forces such as trolls and gnomes.

### Northern and Central Europe

The Netherlands, France, Germany, Austria, and Switzerland have well-developed folk dress traditions. In the Netherlands, rural clothing from various districts is preserved in museums. Simplified versions are worn at events commemorating Holland's association with the sea, as well as in tourist areas such as Volendam and Marken. A typical man's outfit consists of blue woolen trousers and jacket worn with a flat cap and wooden shoes. Winged white caps are characteristic of women's dress.





**Tyrolean men in native costume.** While Austria has eight separate costume districts, Tyrolean clothing is often considered representative of its traditional dress, known as *tracht*. © TIZIANA AND GIANNI BALDIZZONE. REPRODUCED BY PERMISSION.

In France, the proximity of peasants to fashionable Paris stunted development of a folk dress with the exception of a few distinctive customs in distant regions based on long-defunct historical styles. In Brittany, women continued to wear stiffened high lace caps with lappets hanging down the back into the nineteenth century. In the Savoie region bordering Italy and Switzerland, women wore white fluted headdresses and ruffled collars. The women of Provence sported quilted petticoats made from beautiful hand-printed cottons manufactured in the region.

In Germany, Austria, and Switzerland, the folk dress of certain districts is better known than others, thanks to the Romantic movement. German societies formed in the 1880s revived the costumes of the Black Forest and Upper Bavaria. Bavarian costume is still worn today at Munich's Oktoberfest. Austrian folk dress, known as *tracht*, is often synonymous with Tyrolean costume, even though

Austria is divided into eight costume districts. The Tyrolean costume has influenced fashionable dress at various times. In Switzerland, the National Federation of Swiss Costumes was founded in 1926 to preserve regional dress. Swiss folk dress is categorized by canton (geographical division). In the fifth edition of *Ardern Holt's Fancy Dresses Described; or, What to Wear to Fancy Balls* (1887) the most characteristic Swiss dress was that of Berne. Holt recognized that Swiss costumes varied by canton, but dismissed some of them as “not picturesque” (p. 215).

In all three of these countries, women's costumes featured dirndl skirts, fitted vests, white blouses, and distinctive caps, while men's displayed colorful vests and coats worn with knee breeches or leather hose. The latter are known as *lederhosen*—short leather trousers with suspenders—and are worn in both Germany and Austria. A fulled woolen fabric known as *loden* was used for men's clothing in Austria. Woolen embroideries of hearts and



### GENERAL CHARACTERISTICS OF FOLK DRESS

Folk dress on the European mainland typically reflected fashionable dress from various historical periods. Specific features may be traced to medieval, Renaissance, baroque, rococo, neoclassic, or Victorian sources. A basic woman's outfit consisted of a white shift, tight-fitting vest or sleeved jacket, full skirt, apron, shawl, and headgear. Headgear was often the most distinctive part of the costume because it signified marital status; unmarried women wore wreaths or crowns, while married women covered their hair with caps or draped cloths. A typical male folk costume included a simple shirt, a pair of breeches or trousers, a vest or jacket, leather boots or shoes, and a hat. Folk dress varied locally, particularly that of women, depending on availability of raw materials and knowledge of specialized techniques of manufacture peculiar to a region. Most people in a particular district dressed alike because conformity was prized over individuality. Clothing signified membership in a community.

Home production of cloth was integral to folk dress. Both sexes were involved in flax and wool production. Women knew how to spin, weave, knit, and embellish the cloth peculiar to their region. They learned embroidery from pattern books featuring curvilinear patterns such as hearts and flowers. Occasionally special materials (silk ribbons and fabrics) were purchased to trim garments. Some regions specialized in particular textile

techniques, for example lace making or tablet weaving. Local tailors sewed garments of more complicated cut, that included vests, jackets, and coats, and hard-to-handle materials like leather and fur. Women sewed the garments cut from rectilinear pieces of cloth, such as shirts, shifts, skirts, and aprons.

Bast fibers such as flax and hemp grew easily in the moist cool climates of northern Europe; thus, they became the fibers of choice for shirts and cloths for the head and neck. Woolens in medium to dark colors were made into skirts, trousers, breeches, vests, jackets, and coats. In a few regions, leather was used for breeches or trousers. Shoes were of leather, too, although sometimes other available materials like bark or wood substituted for leather. Silk fabrics were a luxury, appearing only in accessories and trimmings.

The industrial revolution made commercially produced fabrics and clothing widely available for moderate prices, gradually replacing hand-woven fabrics and ultimately the homemade clothing itself. In most areas of Western Europe, people stopped wearing distinctive rural styles by 1850. In the early twenty-first century, some Europeans and European Americans wear folk dress to festivals and celebrations as "costume" to signify their affiliation with a particular country or region. The making of accurate reproductions is of great interest to these people.

flowers are common to both men's and women's folk dress in these areas.

#### Mediterranean Countries

One of the most distinctive ensembles of the Mediterranean area is the Andalusian dress of Spain. Situated in the southernmost region, Andalusia absorbed Moorish influence. In the eighteenth century, women began wearing *maja* (female dandy) and *gitano* (gypsy) costumes inspired by the region's machismo culture that glorified bullfighting. The *maja* look incorporated jackets and skirts trimmed with black lace or fringe, mantillas, and hair combs. The *gitana* outfit included ruffled skirts and Manila shawls with colorful embroidery. Men wore tight-fitting jackets and trousers, frilly shirts, and wide-brimmed hats. These popular outfits spread to Madrid and then to the rest of Spain. Eventually Andalusian dress came to represent Spain itself.

Neither Portugal nor Italy has a well-known folk-dress tradition, although regional styles existed in rural

communities in both countries. Portuguese folk dress is characterized by fine embroidery on linen garments.

Greek folk dress has more in common with the Balkan countries than with western Europe. Over the course of its long history, Greece has absorbed influence from Byzantine, Italian, and Turkish culture, resulting in great diversity in the form and decoration of its folk dress. After the Revolution of 1821, islanders and city dwellers abandoned traditional dress in favor of fashionable dress. Like their European compatriots, in the 1840s the bourgeoisie developed a national folk costume consisting of the skirted *foustanella* for men and a fitted jacket, skirt, and fez cap for women. These outfits remain popular to this day as a symbol of Greece and are worn by Greek schoolchildren in Greece and abroad for national celebrations. In the more geographically isolated farming and herding communities, the wearing of regional folk dress continued until the onset of World War II.

See also **Folk Dress, Eastern Europe; Folklore Look; Roma and Gypsy; Scottish Dress; Spanish Dress.**



**Women wearing Andalusian dresses.** In the eighteenth century, Andalusian fashion began to draw inspiration from gypsies and the bullfighting culture, creating a distinctive look that quickly spread across the country. © RICHARD KLUNE/CORBIS. REPRODUCED BY PERMISSION.



## BIBLIOGRAPHY

- Arnö-Berg, Inga, and Gunnel Hazelius-Berg. *Folk Costumes of Sweden*. Translated by W. E. Ottercrans. Västerås, Sweden: ICA bokförlag, 1975.
- Dunlevy, Mairead. *Dress in Ireland*. London: B. T. Batsford, Ltd., 1989.
- Fochler, Rudolf. *Trachten in Österreich [Costumes in Austria]*. Wels-München, Germany: Verlag Welsermühl, 1980.
- Kennett, Frances. *Ethnic Dress*. New York: Facts on File, 1995.
- Nelson, Marion, ed. *Norwegian Folk Art: The Migration of a Tradition*. New York: Abbeville Press, 1995.
- O'Kelly, Hilary. "Reconstructing Irishness: Dress in the Celtic Revival, 1880–1920." In *Chic Thrills: A Fashion Reader*. Edited by Juliet Ash and Elizabeth Wilson. London: Pandora Press, 1992.
- Sichel, Marion. *Scandinavia*. London: B. T. Batsford, Ltd., 1987.
- Snowden, James. *Folk Dress of Europe*. London and New York: Mayflower Books, 1979.
- Stevens, Christine. "Welsh Peasant Dress—Workwear or National Costume?" *Textile History* 33(1) (2002): 63–78.
- Trevor-Roper, Hugh. "The Invention of Tradition: The Highland Tradition in Scotland." In *The Invention of Tradition*. Edited by Eric Hobsbawm and T. Ranger. Cambridge, U.K.: Cambridge University Press, 1982.
- Welters, Linda, ed. *Folk Dress in Europe and Anatolia: Beliefs About Protection and Fertility*. Oxford and New York: Berg, 1999.
- Worth, Susannah, and Lucy R. Sibley. "Maja Dress and the Andalusian Image of Spain." *Clothing and Textile Research Journal* 12(4) (1994): 51–60.

Linda M. Welters

**FOLKLORE LOOK** A folklore look is a style inspired by peasant dress. The term "folklore look" came into use around 1970. However, fashions drawn from peasant costumes have appeared numerous times in the last one hundred years.

#### Antecedents in Exoticism

Fashion has a long history of borrowing from other "exotic" or "primitive" cultures to create new looks that perfectly express the moment. Western fashion's fascination with exoticism dates to the eighteenth century when wealthy Europeans and Americans donned Turkish-inspired ensembles for masquerade and to sit for portraits. The love of things oriental continued into the nineteenth century with the popularity of cashmere shawls, fez caps, and kimonos.

In the first decade of the twentieth century, exoticism found a new proponent—the Paris couturier Paul Poiret. Inspired by the Ballets Russes, he created widely copied ensembles based on middle Eastern and Asian prototypes, often shown with turbans. Soon several constituencies—intellectuals, designers, and politicians—borrowed clothing styles from rural communities to represent specific cultural ideals, thus ushering in the first peasant looks in fashion.



#### HOMEMADE CLOTHING

*Living on the Earth* (Random House, 1971) was written as a guide for those who had rebelled against industrial society by turning to self-sufficient communal living. Author Alicia Bay Laurel showed readers how to raise vegetables, build dwellings, and give birth at home. She also explained how to make clothes. Her hand-lettered book gave simple directions for making your own patterns, remaking secondhand clothes, tie-dyeing, and embroidering. Many of her patterns were based on the simple shapes of folk clothing including a burnoose, a smock shirt, a djellaba, and a Mexican blouse.

#### Early Peasant Looks

Artists, writers, and political activists who settled in New York City's Greenwich Village after 1910 adopted peasant blouses and farmer's smocks to signify their leftist sympathies. Embroidered blouses, sold in Hungarian and Russian shops, became almost a uniform for bohemian women. The city's fashion industry picked up on these new Greenwich Village styles, featuring them in *Women's Wear* (predecessor of *Women's Wear Daily*) and leading department stores like Bonwit Teller.

Similar peasant looks appeared in Paris following the 1917 Bolshevik Revolution, when aristocratic Russian émigrés arrived in the city. In need of money, they began to embroider traditional peasant designs for Kitmir, a company founded by Grand Duchess Marie Pavlovna, daughter of Grand Duke Paul Alexandrovitch. Kitmir's two major clients were Jean Patou and Gabrielle (Coco) Chanel, who produced simple tunics and waistcoats with Russian embroideries for their first postwar collections.

The trend for geometric embroideries on gauzy fabrics coincided with a period in fashion history of clothes with simple shapes and elaborate decoration. Many blouses, delicately embroidered with Slavic motifs, survive from this period in museum collections.

Folk-inspired motifs and shapes appeared in other apparel as well. Sweaters frequently took their inspiration from folk designs, such as the Fair Isle patterns popularized by the Prince of Wales in the 1920s. In the 1930s, skiwear designers looked to Scandinavian, Swiss, and Austrian models for trousers, jackets, sweaters, and caps to wear for this newly fashionable sport. The designer Elsa Schiaparelli included Austrian Tyrol looks in her collections. Peasant styles occasionally sprang from resorts frequented by the rich and famous, such as men's embroidered shirts from Mexico, or ponchos suitable for wearing as beach cover-ups or on board ship.

### Rise of the Hippies

After World War II ended, the popularity of clothing inspired by folk dress faded. The sophisticated lines and elegant fabrics preferred by the two leading postwar couturiers, Christian Dior and Christóbal Balenciaga, were the antithesis of folk looks. Peasant styles found a new home, however, among dissenters who rejected the blandness of the 1950s. Folk music aficionados wore rural-inspired ponchos and peasant shirts. Beatniks added eclectic elements from cultures around the world—Mexican shirts and huaraches, Peruvian vests, Indian sashes, and ethnic jewelry—to signal their marginal social position.

The folk and beat looks of the 1950s signified the beginnings of a rebellion against mainstream society that blossomed into the full-blown “flower power” of the later 1960s. This social transformation, fueled by the coming-of-age of the baby boomers, incorporated the antiwar movement and the new youth culture of sex, drugs and rock and roll. Hippies, as they were known, wore anti-establishment looks borrowed from India, Morocco, Mexico, and Native American communities. The hippie movement foreshadowed the ecology movement; once again the clothes of peasants seemed right for the time. In the 1970s peasant looks merged with ethnic looks, forming the immensely popular “folklore look.”

Authentic folk and ethnic patterns became available to home sewers in the mid-1970s, when three California women founded *Folkwear*. Their first two patterns were for a Syrian dress and a Turkish coat. In the early 2000s, the company offers patterns for smocks, various peasant blouses, shirts, vests, and dirndls.

### Designers and the Folklore Look

Designers inspired by street styles brought the folklore look to high fashion in the 1970s. The English designer Zandra Rhodes observed that in the late 1960s, with the Beatles in India and the Rolling Stones in Morocco, “folklore was appealing.” She found the peasant embroidery and the simple shapes of ethnic clothes “infinitely pleasing” and began creating dresses with ethnic shapes for her hand-painted textiles. Before long, the Paris couture got in on the act, particularly Yves Saint Laurent. His Russian collection of 1976–1977 featured rich peasant looks with full skirts, corselet-type bodices, and short decorated jackets in luxurious fabrics trimmed with fur. This collection introduced colorful scarves, shawls, ruffled skirts, and boots to mainstream fashion.

Since the 1980s any number of designers regularly revived the folklore look. Jennifer Craik describes this process as “bricolage”—the creation of new patterns and styles from a variety of sources, including non-Western dress. Mixing high fashion and everyday clothing is consistent with the postmodern, multicultural world that emerged in the 1980s. At the couture level, Christian Lacroix is known for incorporating peasant elements from Provence into his exotic outfits. John Galliano mixes



**Model in Yves Saint Laurent design.** The folklore look met high fashion in the 1970s, when several well known designers incorporated peasant dress into their clothing lines. © PIERRE VAU-THÉY/CORBIS. REPRODUCED BY PERMISSION.

historical and cultural influences to create innovative designs for Dior. The appropriation of themes from peasant cultures is characteristic of ready-to-wear collections from designers such as Anna Sui, Vivian Tam, Miu Miu, Arden B., and Dolce & Gabbana. Such looks are easily recognizable and move rapidly across the fashion landscape. Indeed, in the spring of 2002, the embroidered peasant blouse was featured by the fashion press as the “look of the moment,” and was soon copied at all levels. Donatella Versace was photographed for the March 2002 issue of *Vogue* wearing jeans and an embroidered peasant blouse purchased from The Ukrainian Shop in New York City. Barely a season later the look was declared passé.

See also **Chanel, Gabrielle (Coco); Ethnic Dress; Folk Dress, Eastern Europe; Folk Dress, Western Europe; Hippie Style; Lacroix, Christian; Patou, Jean; Rhodes, Zandra; Saint Laurent, Yves.**

### BIBLIOGRAPHY

Craik, Jennifer. *The Face of Fashion: Cultural Studies in Fashion*. London and New York: Routledge, 1994.

- Etherington-Smith, Meredith. *Patou*. New York: St. Martin's Press/Marek, 1983.
- Parker, Mary S. *The Folkwear Book of Ethnic Clothing: Easy Ways to Sew and Embellish Fabulous Garments from Around the World*. New York: Lark Books, 2002.
- Polhemus, Ted. *Street Style: From Sidewalk to Catwalk*. London: Thames and Hudson, 1994.
- Rhodes, Zandra, and Anne Knight. *The Art of Zandra Rhodes*. Boston: Houghton Mifflin, 1985.
- Saint Laurent, Yves, Diana Vreeland et al. *Yves Saint Laurent*. New York: The Metropolitan Museum of Art, 1983.

Linda M. Welters

**FONTANA SISTERS** Zoe (1911–1979), Micol (b. 1913), and Giovanna (b. 1915) Fontana were born in Traversetolo, near Parma, Italy. They learned sewing and tailoring from their mother, Amabile Fontana, who opened her own tailor shop in 1907. The three sisters became apprentices as soon as they were old enough to handle needles and scissors. Legend has it that the work was hard and unpaid and that the sisters worked Saturdays and Sundays. Despite the long hours, the sisters' memories of childhood are happy ones, and they look back with fondness on the years spent in the large, quiet house surrounded by greenery. Micol writes often of her childhood experiences in her memoir, *Specchio a tre luci*. "We were never alone, but always accompanied by our mother's love" (p. 20).

### Apprenticeships

In the 1930s Zoe, the eldest of the three, left Traversetolo to become an apprentice in Milan. Micol joined her there, while Giovanna remained in the countryside. Shortly after her marriage in 1934, Zoe moved with her husband to Paris, where she continued her apprenticeship in an atelier. After returning to Italy in 1936, Zoe, excited by her experiences in Paris, moved to Rome. In her memoirs she treats this major turning point in her life casually: "I took the first train that arrived. . . . It could have gone north or south. It happened to be going south, to Rome" (2001, p. 14). After her sisters joined her in Rome, Zoe went to work for Zecca and Micol for Battilocchi; Giovanna sewed garments at home. Based on their experiences in Milan and Paris, the sisters felt they were ready to go into business for themselves. Although French fashions were still dominant in the world of haute couture, the sisters opened their own workshop in Rome in 1943, changing the name from "Fontana" to "Sorelle Fontana" and leading members of the Italian aristocracy soon began patronizing it.

### International Fame

However, their Roman clientele would not have been sufficient to cement the Fontana sisters' reputation if Hollywood had not discovered Italy and *la dolce vita romana*

in the 1950s. One of the events that helped secure their international reputation was the marriage of the Hollywood actors Tyrone Power and Linda Christian, whose wedding gown the Fontana sisters designed. The ceremony was held in the basilica of Santa Francesca Romana in Rome in 1949. The gown was constructed of white satin, with a five-yard train, and was covered with embroidery; it resembled a dress that might have been worn by a fairy tale princess. The international press covered the event, and photographs of the ceremony and a radiant Linda Christian appeared in papers around the world. A magazine published for foreign tourists in the 1950s proclaimed, "Rome? Twenty minutes in St. Peter's, twenty in the Coliseum, and at least two days in the Fontana sisters' studio" (Soli, p. 75).

In 1951 the Fontana sisters participated in the first fashion show held in Florence, which was organized by Giovanni Battista Giorgini, the promoter of Italian fashion and organizer of catwalk shows at Sala Bianca, Palazzo Pitti. That same year Micol Fontana left for Hollywood, arriving in the United States as the guest and personal friend of Tyrone Power and Linda Christian. Power organized a show for her because he wanted to introduce other members of the Hollywood community to the Fontana sisters' designs. From that moment on, the Fontana sisters began designing for many of Hollywood's best-known stars, from Ava Gardner to Elizabeth Taylor, and started developing a varied international following as well. Margaret Trujillo (the Santo Domingo dictator's wife who ordered Sorelle Fontana's atelier 150 dress), Grace Kelly, Margaret Truman (President Harry S. Truman's daughter), Jackie Kennedy, Soraya Esfandiary, Marella Agnelli (of the family that runs the Fiat), and Maria Pia di Savoia (one of the daughters of last king of Italy, Umberto of Savoia) were some of their regular customers. From Linda Christian Marriage, they also specialized in celebrities' wedding dress: Margaret Truman (1956), Janet Auchincloss, Jacqueline Kennedy's sister (1966), Maria Pia di Savoia (1955), whose dress is now shown at the Museum of Art and Costume in Venice, and Angelita Trujillo, the daughter of the Santo Domingo dictator (1955), are some examples.

In 1957 the Fontana sisters were received by Pope Pius XII to mark fifty years of tailoring begun by their mother, Amabile. In 1958 they were invited to the White House as Italy's representatives to the Fashion around the World conference. In 1960, at the request of American customers, they introduced a line of ready-to-wear. This product launch was followed by a line of furs, umbrellas, scarves, costume jewelry, and table linen. Because of the careful division of labor among them, the three sisters were invincible: Micol traveled around the world—Japan, Europe, and ninety-four trips to the United States, Zoe handled public relations, and Giovanna monitored work in the studio.

In 1972, while continuing their work in couture and ready-to-wear, the sisters withdrew from most of the of-



ficial fashion shows. In 1992 the Fontana label and the company itself were sold to an Italian financial group. In 1994 Micol created the Micol Fontana Foundation, the mission of which is to promote fashion and the training of talented newcomers.

### Inspiration for Designs

The Fontanas' designs, although they referred to French models, were inspired by eighteenth-century modes of dress, which were based on designs of the early Renaissance. The sisters were able to navigate between Parisian haute couture, an essential reference point, and the originality of the Italian fashions with which American women had become enamored. The sisters' designs were known for craftsmanship and intuition. Embroidery, lace, and impeccable tailoring were characteristic of their garments. They specialized in formal wear and evening gowns and used the most precious materials, including silk and velvet. Their ideas came from a wide variety of sources, but their designs, for the most part, were Italian in inspiration. Quintavalle remarked that the Fontana sisters "redeemed the Italian culture that Fascism had disfigured, restricting it within the confines of a local culture" (Bianchino, p. 43).

### Innovations

The sisters' love for America continued to deepen. In her diary Micol writes that she felt more at home in America than in Italy and that public relations was not the only reason she traveled. Micol was a close observer of the way Americans dressed, and she tried to determine exactly what they wanted to wear. The sisters' relations with the international jet set, and especially with Hollywood and the film industry, were one of their strengths; in fact, Nicola White remarks that it is unlikely they would have been able to achieve such fame without their connection to Ava Gardner, as well as to other stars like Myrna Loy, Grace Kelly, Audrey Hepburn, and Kim Novak. However, their skill as couturiers, which allowed them to compete with Dior's Paris, cannot be overlooked. The clothing they created was designed for the individual client. Zoe, known as the "golden scissors," could cut and drape as well as the best designers in Paris.

Renato Balestra and Alain Reynaud, the creators of Biki, are among the designers who had worked with Sorelle Fontana. By presenting some of their designs in newspapers—an innovation resulting from their ability to intuit future developments in fashion—they took another step in consolidating their fame, completely altering their relationship with the public. Unlike other designers, their relations with their clients did not develop through frequent customer visits to their studio, which had typified the role of the designer until then. Most of their clients learned of them through the media and wanted to meet the sisters so they would design something for them. In this sense they helped lay the foundations for the star designers of the future.



**Woman modeling Sorella Fontana design.** The Fontana Sisters exported Italian fashion to the rest of the world, especially to the United States, where they designed clothing for some of Hollywood's most famous stars. AP/WIDE WORLD PHOTOS. REPRODUCED BY PERMISSION.

Italian cinema put the atelier of the Sorelle Fontana under the spotlights when it became the set for the film *Le ragazze di piazza di Spagna* by Luciano Emmer (1953). The Fontana sisters also designed the costumes for Ava Gardner in *The Barefoot Contessa*, a film released in 1954. One of their designs, the "cassock dress," which was made for Gardner in 1956, was used by the costume designer Danilo Donati for Anita Ekberg in Federico Fellini's film *La dolce vita*. The Fontana sisters' work has been presented in several exhibitions and designs are exposed in

the museums internationally: the Metropolitan Museum of Art in New York, the Metropolitan Museum of Art in San Francisco, the Museo d'Arte e Costume in Venice, and the private library of Harry Truman.

See also **Evening Dress; Haute Couture; Wedding Costume.**

#### BIBLIOGRAPHY

- Bianchino, Gloria. *Moda dalla fiaba al design*. Novara, Italy: De Agostini, 1989.
- Fontana, Micol. *Specchio a tre luci*. Roma: Rai Radiotelevisione Italiana, 1992.
- Gastel, Minnie. *50 anni di moda italiana*. Milan: Vallardi, 1995.
- Giordani Aragno, Bonizza. *900 Il Secolo Di Moda: Sorelle Fontana*. Roma: Fondazione Micol Fontana, 2001.
- , ed. *Storia di un atelier: Sorelle Fontana 1907–1992*. Rome: Logart Press, 1992.
- Pisa, Paola. "Sorelle Fontana." In *Dizionario della moda*. Edited by Guido Vergani. Milan: Baldini and Castoldi, 1999.
- Soli, Pia. *Il genio antipatico*. Milan: Arnoldo Mondadori, 1984.
- White, Nicola. *Reconstructing Italian Fashion*. London, New York: Berg, 2000.

Simona Segre Reinach

**FOOTBINDING** Footbinding was specific to and unique to traditional Chinese culture. Its various names conveyed its multifaceted image in Chinese eyes: *chanzu* (binding feet) called attention to the mundane action of swaddling the body with a piece of cloth; *gongwan* (curved arch) described a desired shape of the foot similar to that of a ballerina in pointe shoe; *jinlian* (golden lotus, also gilded lilies) evoked a utopian image of the body that was the subject of fantastical transformation. A related poetic expression of *lianbu* (lotus steps) suggested that footbinding was intended to enhance the grace of the body in motion, not to cripple the woman.

#### Body Modification

The much-maligned practice has often been compared to corsetry as evidence that women were oppressed in cultures East and West, modern and traditional. The comparison is apt albeit for different reasons. The goal of both practices was to modify the female figure with strips of carefully designed and precisely positioned fabric, and in so doing alter the way the wearer projected herself into the world. During its millennium-long history, footbinding acquired various cultural meanings: as a sign of status, civility, Han Chinese ethnicity, and femininity. But at its core it was a means of body modification, hence its history should be sought from the foundational garments of binding cloth, socks, and soft-heeled slippers.

The materials needed for binding feet were specialized articles made by women (binding cloth, socks, and shoes) together with sewing implements readily available

in the boudoir (scissors, needle, and thread). Alum and medicinal powder were sprinkled between the toes as an astringent. Women often wove the cotton binding cloth; its average width was three inches, and its length ranged from seven to ten inches. Skillful wrapping of the cloth allowed the woman to reshape the foot into desirable shapes in accordance to footwear fashion. The method and style of binding feet varied greatly with geography, age, and occasion. A moderate way involved compressing the four digits into a pointy and narrow tip; an extreme regiment required both the folding of the digits and the bending of the foot at midpoint into an arch. The tendons and extensors of the toes were stretched to the point of breakage, but the breakage did not, at least in theory, require fracturing the bones. The binding of feet altered the shape of the foot and the woman's gait. Slender slippers and dainty steps signified class and desirability.

Similar to tattooing, footbinding bespeaks an attitude that viewed the body as a canvas or a template—a surface or “social skin” on which cultural meanings could be inscribed. Yet the effect of binding was more than skin deep. It signaled an extreme form of self-improvement and mastery; the contemporary body-piercer's motto of “no pain, no gain” is equally apt for Chinese women.

Unlike tattooing and body-piercing, however, footbinding was only practiced by females, and its connections with the female handicraft traditions of textile, embroidery, and shoemaking rendered it a quintessential sign of feminine identity. It is paradoxical that footbinding, supposedly a signal of the woman's family status as “conspicuous leisure,” was in itself a result and expression of a strenuous form of female labor.

#### Early Beginnings

The earliest material evidence for the binding of feet is several pairs of shoes from twelfth- to thirteenth-century tombs in south-central China. Scholar Zhang Bangji (fl. 1147) provided the first known textual reference to footbinding as an actual practice: “Women's footbinding began in the recent times; it was not mentioned in any books from the previous eras.” By the twelfth century, footbinding was a common but by no means mandatory practice among the wives and daughters of high-status men, as well as courtesans and actresses who entertained this same group of privileged scholar-officials.

Song-dynasty China (960–1279) enjoyed a prosperous commercialized economy. The Northern Song capital of Kaifeng and the Southern Song capital of Hangzhou, with populations of over a million each, were the largest cities in the world at the time. Indeed, historians have suggested that the beginnings of Chinese modernity can be traced back to the Song. A taste for novelty, together with status-anxiety—the same factors that gave rise to fashion in early modern Europe—also facilitated the birth of footbinding. Adoration for small

feet ran deep in Chinese culture: the story of Ye Xian, China's Cinderella, appeared in a ninth-century story collection *Youyang zazhi* (Ko, pp. 26–27), and poets eulogized dainty steps and fancy footwear from the sixth to tenth centuries. But these fantasies gave rise to the actual practice of binding feet only in the urban culture that emerged after the fall of the Tang aristocratic empire.

The style of women's shoes from the twelfth to fifteenth centuries conforms to two subtypes: one is long and narrow with pointy toes, like a kayak; the other, with turned-up toes, is like a canoe with a high stem. These shoes are made of monochrome silk and decorated with embroidered abstract floral or cloud patterns. The length of archaeological specimens ranges from 5.9 inches to 9.4 inches (15 to 24 cm). Both styles feature flat fabric soles, suggesting that in this early stage women swaddled their four digits together with a binding cloth to achieve a sleek, pointy look.

Paintings show these pointy toes or the more dramatic upturned toes peeking out from long, flowing silk trousers, creating an aesthetic of subdued feminine elegance. The most credible origin myth attributes footbinding to Yaoniang, a dancer in the court of the last ruler Li Yu (r. 969–975) of the Southern Tang kingdom, who beguiled Li with her graceful dance and shoes that “curl up like the new moon.” In the beginning, footbinding was not meant to cripple.

### The Cult of the Golden Lotus

A more extreme regime of beauty arose around the sixteenth century with the invention of high heels. One type of shoes was elevated on a cylindrical heel; another featured a curved sole supported by a piece of silk-covered wood from the heel area to the instep. Not only did heels afford an optical illusion of smallness, they also enabled an extreme way of binding that pushed the base of the metatarsal bones and the adjoining cuneiforms upward, forming a bulge on the top of the foot. A crevice was formed on the sole due to the compression of the fifth metatarsal bone toward the calcaneus or heel bone. The high heel redirected the wearer's body weight into a tripod-like area consisting of the tip of the big toe, the bent toes, and the back of the heel. However unsteadily, heeled footwear provided better support for the triangular foot than flats.

This strenuous regimen bespeaks heightened female competition in a fashion-conscious society. In the sixteenth century, the Ming Empire (1368–1644) enjoyed the largest trade surplus in the world. Buoyed by a net inflow of New World silver, the money economy spread to the countryside. In a world of material abundance and social fluidity, there was intense pressure on women to display the status of their fathers and husbands. The incessant drive for small feet and their attendant eroticization in this atmosphere gave rise to a cult of the golden lotus.



**Silk Ginlein shoe.** Footbinding is a form of body modification mainly practiced by Han Chinese women. One of the two popular styles of shoes available to women with bound feet in the twelfth to fifteenth centuries was made of silk with embroidered patterns and pointed toes. Shoes in this style averaged in length between 15 and 24 centimeters. COURTESY OF THE BATA SHOE MUSEUM, TORONTO. PHOTO BY HAL ROTH. REPRODUCED BY PERMISSION.



**Cantonese boots.** High-heeled shoes were introduced to women's fashion in China during the Ming Dynasty. The heels created the illusion of smallness and, due to the shoes' design and the weight and balance modifications resulting from footbinding, they actually provided more support to women with bound feet than did flat shoes. COURTESY OF THE BATA SHOE MUSEUM, TORONTO. PHOTO BY HAL ROTH. REPRODUCED BY PERMISSION.

Female footwear—often store-bought—became fanciful. Some women hired famous carpenters to carve their heels, often of fragrant wood. Floral cutouts were made on the surface of hollowed heels; perfumed powder inside the heels would leave traces of blossoms on the floor as the wearer shifted her steps. The shoe uppers were fashioned from red, white, or green silk with increasingly elaborate embroidered motifs of auspicious symbols. The earlier flat socks evolved into contoured and footed soft “sleeping slippers” which women wore to bed on top of the binding cloth. The erotic appeal of the golden lotus





### THE FETISHISM OF BOUND FEET AND TINY SHOES

William Rossi has suggested the bound foot was “the organ of ultimate sexual pleasure”; the soft fleshy cleavage on the underside of the foot was “the equivalent of the labia” for men (pp. 29–30). Although this view is corroborated by Chinese erotic paintings from the nineteenth and twentieth centuries, no premodern Chinese sources depict footbinding in this light.

Novels, poetry, and prose by premodern Chinese male scholars suggest that embroidered slippers and partially undressed, but still concealed, feet served as the locus of their erotic imagination. The first credible connoisseur of bound feet was the Yuan dynasty scholar-poet Yang Weizhen (also known as Yang Tieya, 1296–1370), who in his later years retired from the court and dallied in the garden city of Suzhou. To add to the merry-making, Yang drank from wine cups fashioned from courtesans’ tiny shoes. Brothel drinking games involving the tiny shoe persisted and became more fanciful, as evinced by the connoisseur Fang Xuan’s (probably a pseudonym) treatises first published in the last decade of the Qing dynasty (Levy, pp. 107–120).

The connoisseur Li Yu (c. 1610–1680)—no relation to the Southern Tang ruler—described the sexual appeal of the bound foot in both visual and tactile terms. In a bedroom scene in Li’s erotic novel *The Carnal Prayer Mat*, the protagonist Vesperus removed all the clothes of Jade Scent but left her leggings on, because “in the last resort tiny feet need a pair of dainty little leggings above them if they are going to appeal” (p. 50). Li recounted his own experience of removing courtesans’ stockings to fondle feet so soft that they feel “boneless” in an essay collection, *Casual Expressions of Idle Feeling*. Presum-

ably the binding cloth was not removed. Li added: “Lying in bed with them, it is hard to stop fondling their golden lotus. No other pleasures of dallying with courtesans can surpass this experience” (Hanan, p. 68).

The most vivid Chinese account of the fetishism of shoes and feet during the height of the cult of the golden lotus is the erotic novel *The Plum in the Golden Vase*, first published in 1618. Presiding over a polygynist household, the protagonist Simen Qing is the paragon of male privileges and excesses. Females vie to get his attention, hence their heart’s desires, by a parade of tiny shoes they designed and assembled. Simen was partial to red sleeping slippers; his love for them—and their wearer—was transference for his own desire to wear red shoes (chapter 28). Simen, a merchant, personifies the commodity culture that enabled new economies of pleasure and desire in seventeenth-century China.

Chinese fetishism assumes different meanings than that which crystallized in Europe in the second half of the nineteenth century, in part because the association of pleasure and guilt is absent in Confucian morality. But in China as in Europe, the fetishism of the foot found its most graphic expression in the spectacular details lavished onto high heel shoes. As a vessel for wine, plaything, or token of exchange, embroidered slippers were receptacles of boundless fantasy.

The very subject of footbinding has been fetishized in the West. As a stand-in for the exotic and erotic Orient, footbinding has continued to fascinate modern observers and collectors after its demise in China as a social practice.

was wrought of layered footwear as instruments of concealment.

Even at the heyday of the cult, many women did not have bound feet. Footbinding was more a privilege than a requirement. Women of Manchu descent, an ethnic minority group, eschewed footbinding, as did Hakka women, who shouldered back-breaking manual labor. After the Manchus became the rulers of China in 1644, they issued prohibition edicts that only served to make footbinding more popular among the subjugated Han Chinese majority.

#### The Anti-Footbinding Movement

The decline of footbinding can be attributed to internal and external factors. Domestically, it became a victim of its own success. As footbinding spread geographically

outward and socially downward during the Qing dynasty (1644–1911), it lost its *raison d’être* and ceased to be a sign of exclusivity. Externally, Christian missionaries and merchants brought an imported concept of the natural God-given body as well as a new sartorial regime in the second half of the nineteenth century. Footbinding became so dated that it was synonymous with “feudal and backward China” in the Republican period (1912–1949). Although coastal women gave up the practice in the early decades of the twentieth century, girls in the remote southwestern province of Yunnan were forced to stop by the Communist regime only in the 1950s.

Ironically, on the eve of footbinding’s decline, the paraphernalia of footbinding reached the height of its glory, surpassing previous centuries in rapidity of stylistic changes and ornamental techniques. Each region de-

veloped its own distinct footwear styles. New genres of patterns, snow clogs, and rain boots served the growing number of working-class women with bound feet. Footwear innovation continued into the 1920s and 30s, when women with bound feet updated their wardrobes with such Western styles as the Mary Jane, fastened with buttons and flesh-colored silk stockings.

In sum, there is not one footbinding but many. During each stage of its development the way of binding, shoe styles, social background of the women and their incentives are different; the regional diversities are also pronounced. But in the final analysis, the binding of feet was always motivated by a utopian impulse to overcome the body and to elevate one's status in the world.

See also **China: History of Dress; Fetish Fashion.**

#### BIBLIOGRAPHY

- Feng, Jicai. *Three-Inch Golden Lotus*. Translated by David Wakefield. Honolulu: University of Hawaii Press, 1994. A realistic novella that explores the complex female psychology during the anti-footbinding period.
- Hanan, Patrick. *The Invention of Li Yu*. Cambridge, Mass., and London: Harvard University Press, 1988. An introduction to the life and times of Li Yu, maverick writer and connoisseur of bound feet.
- Ko, Dorothy. *Every Step a Lotus: Shoes for Bound Feet*. Berkeley and Los Angeles: University of California Press, 2001. Includes an illustrated chart of regional footwear styles and a discussion of shoemaking tools.
- Levy, Howard S. *Chinese Footbinding: The History of a Curious Erotic Custom*. Taipei: Nantian shuju, 1984. A convenient summary of the six-volume *Caifei lu*, a Chinese encyclopedia on footbinding, and early Japanese scholarship on the subject.
- Li Yu. *The Carnal Prayer Mat*. Translated by Patrick Hanan. Honolulu: University of Hawaii Press, 1990.
- The Plum in the Golden Vase, or Chin P'ing Mei*. Volume 2: *The Rivals*. Translated by David Tod Roy. Princeton, N.J.: Princeton University Press, 2001.
- Rossi, William A. *The Sex Life of the Foot and Shoe*. Ware, Hertfordshire, U.K.: Wordsworth Editions, 1989.
- Steele, Valerie. *Fetish: Fashion, Sex and Power*. New York and Oxford: Oxford University Press, 1996.
- Wang, Ping. *Aching for Beauty*. Minneapolis: University of Minnesota Press, 2000. A Chinese woman's poetic evocation of the male and female desires that sustained the thousand-year custom.
- Zhang, Bangji. *Mozhuang manli*. In *Congshu jicheng chubian*, nos. 2864–2866. Changsha: Shangwu, 1939.

Dorothy Ko

**FOOTWEAR.** See **Shoes.**

**FORD, TOM** In his role as creative director for the Gucci Group, designing collections for both Gucci and Yves Saint Laurent, Tom Ford was central to early twenty-first-century fashion. Under Ford's direction,



**Tom Ford.** Ford began designing for Gucci in 1990, rescuing the company from serious financial trouble partly by placing greater emphasis on its line of accessories. AP/WIDE WORLD PHOTOS. REPRODUCED BY PERMISSION.

creativity and innovation shared equal value with marketing and promotion in the positioning of the brands.

Born in 1962 and raised in San Marcos, Texas, and Santa Fe, New Mexico, Ford first began his career as a model for television advertisements before studying interior design at Parsons School of Design in New York City. In his final year of school, he changed his focus to fashion design. As a freelance designer on Seventh Avenue, he first worked for Cathy Hardwick and then in 1988 in the jeans department of Perry Ellis, under the short-lived direction of Marc Jacobs.

In 1990, the company's worst year financially, Ford was appointed womenswear designer at Gucci. Because of loss of strategic and creative direction and in-house family feuding, the company was losing 340 billion lire annually. In 1992 Ford was appointed design director, and in 1994, creative director; by the first six months of 1995, the company's revenues had increased by 87 percent. This financial turnaround was largely achieved by a consolidation of the company's product range, editing out weak licenses for vulgarly branded goods and re-designing core items, typified by the reappearance of the classic Gucci loafer in rainbow hues (1991) and the success of the Gucci platform snaffle clog (1992).

The international recognition of Gucci as a producer of prêt-à-porter collections was crystallized by the autumn/winter season of 1995–1996. From the prevailing aesthetic of pared-down minimalism and understated luxury, Ford presented a sleek, retro-inspired collection evoking a somewhat louche sexuality. The look was defined by velvet hipster trousers with a kick at the heel and a narrowly cut silk shirt, accessorized with a large, unstructured shoulder bag and matching platform court shoes in patent leather with a metallic shine normally associated with car chassis.

The collection was pivotal, as it established a trend for the consumption of seasonal fashion defined not so much by a total look as by how the look could be attained through buying the “must-have” accessory. As Ford later suggested, “You have to get the product right, it’s the most important aspect.” Much of this success was achieved through the advertising campaigns the company produced with fashion photographer Mario Testino, where the glamorous proposition of the dressed models was matched on the opposite side of the spread by an isolated close-up of the accessory. The close relation between the image of Gucci and its advertising campaigns eventually produced a lapse in confidence, when for the spring/summer collections in 2003 the company ran an image of a model who had her pubic hair shaved into the Gucci “G.” The image was widely criticized for being too blatantly sexual and in dubious taste. Meanwhile, the Gucci Group had acquired the Yves Saint Laurent (YSL) brand after the legendary designer retired from the couture. From an uncelebrated opening collection (largely due to the French press berating an American ready-to-wear designer for having the audacity to step into the most hallowed of shoes), the brand developed consistently and confidently, particularly from Ford’s gaining access to the YSL archive.

Through his close relation to Domenico de Sole, CEO of the Gucci Group, Tom Ford was central to the increasing dominance of the company in the designer fashion and luxury goods market, as Gucci acquired stakes in Balenciaga, Alexander McQueen, Stella McCartney, Bottega Veneta, and Sergio Rossi. The unexpected 2003 announcement of Ford’s departure from the Gucci group, effective in April 2004, shook the fashion world, and speculation immediately began about his successor as well as about his own future plans.

*See also* Gucci; Saint Laurent, Yves; Shoes.

#### BIBLIOGRAPHY

Ford, Tom, for Gucci. *Light. Visionaire* 24. New York: Visionaire Publishing, 1998. Unique, multiformat album of fashion and fine art published three times yearly in numbered, limited editions. Artists are given freedom to develop a theme. In issue 24 *Visionaire* and Tom Ford created the first such publication that is battery-operated. Only 3,300 copies were made.

Forден, Sara Gay. *The House of Gucci: A Sensational Story of Murder, Madness, Glamour, and Greed*. New York: Perennial, 2001.

*Alistair O'Neill*

**FORMAL WEAR, MEN'S** The quintessence of uniform elegance in men’s wear must surely be those nearly unchanging garments described as “formal.” The exact opposite of “casual” clothes, men’s formal garments are as curiously elevating and ennobling as they are utilitarian and leveling. This might seem a contradiction in terms at first, but one has only to think of a “black-tie” event to realize that at least en masse, the uniform nature of the clothes—coded and easily recognizable globally—places all men in the same category, much like a uniform does for the army, navy, or air force. But like the armed forces, which have panoplies of different ranks, a tangible difference in provenance can be evinced in evening or formal clothes. Is this suit custom-made? Is that rented? Is that a hand-me-down? Is this a lucky find in a vintage market?

A black-tie event is a sea of ebony and ivory—all men, although from different ranks in society, at least visually and superficially are united by convention. Formal wear not only functions as a social leveling device for the men at a gathering, but it also provides a uniform backdrop (or perhaps, “black-drop”) for the female guests who are of course, not restricted to the color black for their gowns. Formal clothes have an air of assured authority and confidence about them and are generally resistant to fashion, although of course some designers attempt to play with their strictures from collection to collection. But customers always seem to revert to the history, tradition, and timeless style of the unshakable classics.

The most recognizable formal wear costume is the black-tie—in the United States, usually referred to as the tuxedo and frequently shortened to “tux.” In 1896, a mischievous, iconoclastic dandy, Griswold Lorillard, wore a shorter, black formal jacket (without tails) to a country club in Tuxedo Park, New York—and the name was established. The jacket part of the black-tie ensemble is sometimes referred to as a “dinner jacket,” though that appellation is too limiting to encompass all its myriad social functions. Essentially, the terms all refer to the same costume, though some contend that the classic tuxedo jacket must have a shawl collar rather than peaked lapels, and many would permit no color other than black (some will allow cream). But these distinctions have more to do with the wearer’s upbringing and taste as opposed to the outfit itself.

There are generally five styles to choose from: single-breasted, double-breasted, peaked lapels (usually double-breasted) and single- or double-breasted shawl collared. Basically, it is a black suit but ennobled by a silk or gros-grain facing on the lapels, the better to provide a sug-



gestion of luxury and attention to detail. And black-tie is, and should only ever be, black—or perhaps midnight blue, which the late royal couturier Sir Hardy Amies always maintained looked blacker than black itself, under artificial light. A corresponding black silk or grosgrain stripe runs down the sides of the trouser—again echoing uniform pants.

The shirt is always white. It can be made in anything from the finest zephyr cotton to polyester—but it must always be white. Pearl buttons or studs are the norm and a wing collar a matter of choice and taste, although if one is sported it should be buttoned on or studded through—not ready-made. And the bow tie is not considered one if it is not hand-tied. Aficionados frown upon the ready-made examples with elastic and hooks. Cummerbunds are reserved for the most formal of occasions, but they do have a small function which rescues them from being pure items of conspicuous consumption; in their pleats is concealed a tiny pocket for small essentials.

While the basic elements of formal wear are conveniently precise, the wearer is able to exert his individuality through the sporting of discreet (or not so discreet) items of jewelry—these for the most part being concealed by the jacket cuff in the form of links or by the jacket itself if a spirited watch chain or fob is attached to a waistcoat.

The *luxe de luxe* of formal wear is white-tie, an ensemble that includes tails, wing-collared shirt, hand-tied white bow tie usually in a cotton pique or fine grosgrain, and corresponding white waistcoat—traditionally three buttoned and cut low to expose maximum shirt front. For the feet, nothing but glacé, glossy pumps will suffice, topped off with a pair of silk, decorative bows. And at the other end of the body, a top hat—in glossy black silk—is the point finale. This look was established as a sartorial must by the early 1920s. Whether formal or extremely formal, the basic sonorous quality of the ensemble is the color black. As the costume historian James Laver has pointed out, since the eighteenth century, all attempts to introduce color to male formal attire have failed or have been derided. A shiny, colorful, patterned male evening ensemble is unthinkable; such is the continuing power and influence of tradition.

Formal daywear is now found primarily in the world of sports, and especially of horse racing and boat racing. Royal Ascot, Goodwood, and Henley are social institutions where formal clothes are demanded and specific dress code requirements are imposed on all who attend. Formal wear for Royal Ascot would be full morning dress (dove gray or black); the groom or the bride's father at a formal daytime wedding would wear the same ensemble. The coat is sometimes referred to as a cutaway coat (being a frock coat with the corners removed), not to be confused with a tailcoat, which is cut to the waist in the front, and sports a pair of tails behind. A gray, buff, or for the more fashion conscious, brightly colored and pat-



**Man in formal attire.** Elegant and sleek, a man's Black Tie costume, or tuxedo, is comprised of jacket, pants with matching stripe, white shirt, and hand-tied bow tie. © JOSE LUIS PELAEZ, INC./CORBIS. REPRODUCED BY PERMISSION.

terned silk waistcoat, is worn beneath and teamed with a tie, cravat, or some other individualistic neck wear—but never a bow.

The origin of formal wear is open to discussion and challenge, but one name forever associated with formality, uniformity, and simplicity was Beau Brummell—king of the dandies and a one-time favorite of King George IV. He is often referred to as the “father of modern male formal costume” as he eschewed the brightly hued silken finery and powdered wigs generally worn at court for a sober suit of midnight blue-black with minimal jewelry (a signet ring was permissible), no wig, no perfume but plenty of shaving and washing—a well-scrubbed appearance being the natural partner to formal dress.

It is the Beau whom many think invented or at least popularized the under-the-foot strapped pantaloons (from the French—*Pend en talon*—to the heel) and set the standard for what would become the ubiquitous tailcoat. Brummell was belligerently exact when it came to matters of formal and what came to be “court dress.” To



**Men's formal wear.** Formal attire for men has seen little change since the nineteenth century. These men are modeling the fashions of 1932, ranging from the highly formal tuxedo on the right to less formal business attire at left. © BETTMANN/CORBIS. REPRODUCED BY PERMISSION.

a would-be dandy seeking sartorial approval he snapped, “Do you call that *thing* a coat?” Brummell made formality look simple—challenging the brightly colored costumes in feminine fabrics like silk and velvet for the sharp masculinity of well-cut wool and flannel. Thus formal wear showed and still does show its class by line, not content.

In the twenty-first century, the reduction of occasions on which to wear formal clothes has curiously thrown a sharper light on these style stalwarts. Not even a hundred years ago, BBC radio announcers were required to wear black-tie—the premise being that the stiff formality of the shirt, bow tie, and exact-fit jacket aided the gravitas of the voice and the assurance of the delivery. At weddings and funerals, formal clothes were obligatory and many other social situations demanded this “civilian uniform” as a means of maintaining a required ambiance, from balls and tea dances to memorials and visits to the opera. Just a hundred years ago, dressing for dinner in one’s own home could have meant having to wear full formal dress—even if it was just with family members. A visit to almost any vintage clothing fair or market will reveal several yesteryear formal garments for men—a clue as to how vital they were and perhaps how few the occasions for which they are needed in the early 2000s.

In the mid-1950s, everyone who could afford to have at least one formal outfit owned one, which would most often be mothballed until needed. Those who did not own formal wear relied on borrowing from relatives or renting. The formal rental market is still hugely successful with providing formal wear for weddings to royal garden parties and theatrical opening nights. The respect that formal wear lends to the occasion is thus implied—even if not required or requested—and many will opt for formality to suggest this. Those who have chosen casual attire will be thrown into sharp contrast. Perhaps formal wear represents the last bastion of constancy in clothing with a conspiratorial nod to time, not trend.

See also **Brummell, George (Beu); Tuxedo.**

#### BIBLIOGRAPHY

- Curtis, Bryan, and John Bridges. *A Gentleman Gets Dressed Up: Knowing What to Wear, How to Wear It, and When to Wear It*. New York: Rutledge Hill Press, 2003.
- Flusser, Alan. *Dressing the Man: Mastering the Art of Permanent Fashion*. New York: HarperCollins Publisher’s Inc., 2002.
- Hollander, Anne. *Sex and Suits: The Evolution of Modern Dress*. Tokyo and New York: Kodansha International, 1995.

*Robin Dutt*

**FORTUNY, MARIANO** Although Mariano Fortuny considered himself a painter, he pursued various critical and aesthetic interests. He is primarily remembered for remarkable layers of dyed and patterned fabrics, which he created between 1906 and 1949. Born in Granada, Spain, to an upper-class family of distinguished painters, Mariano Fortuny y Madrazo (1871–1949) is more often associated with the city of Venice, Italy, where he lived and worked most of his life.

As a child, Fortuny was surrounded by eclectic assemblages of ephemera: antique textile remnants, carpets, costumes, vestments, furniture, armor, and implements of war collected as art objects. Following the untimely death of his father, the painter Mariano Fortuny y Marsal, in 1874, young Mariano, his mother, and his sister moved to Paris in 1875. Although he considered himself self-taught, he was guided toward the arts by his uncle Raymundo, a painter, and informally by the sculptor Auguste Rodin. He later expanded his education in Germany, where he studied physics and chemistry. In 1889 the Fortuny family traveled to Venice; finding it a romantic and artistic center, they moved there permanently in 1890.

### Business Innovations

Fortuny's garments and textiles fuse history, anthropology, and art. By blending various dyes he achieved luminous, unique colors. Resurrecting the ancient craft of pleating fabric, artistically symbolizing a reflection of the sun's rays, Fortuny developed his own interpretation of this craft and registered his heated pleating device in 1909. Between 1901 and 1933 he registered twenty-two patents, all of which related to garments and printing methods. Prolific in artistic pursuits, he printed etchings, invented a type of photography paper, designed lamps and furniture, bound books, and maintained an extensive, private reference library. He displayed his own artistic creations in the ground floor showroom of his residential palazzo.

An interest in Richard Wagner's operatic productions drew Fortuny to Bayreuth, Germany, in 1892. Fascinated by the dramatic spectacle unfolding before him, he developed a revolutionary, indirect lighting system that transformed cumbersome stage scenery and obsolete gas lamps, significantly changing the atmosphere onstage. Commissioned by an art patron, he constructed two enormous, vaulted quarter spheres of cloth, expanded over a collapsible metal frame, which amplified color and sound. The spheres were 225 square meters (269 square yards) in area and 7 meters (7.6 yards) high. His first theatrical costume was a figure-enveloping, border-printed scarf titled the Knossos, presented in a private theater in 1907. Isadora Duncan was the first to wear the Knossos scarf. At the home of his patron Cotesse de Bearn in 1906 in Paris, his stage lighting system first appeared as well as his first textile creation printed with geometric motifs. This theatrical endeavor transformed his awareness and appreciation of materials into a tactile form, quite separated from his representational works.

Fortuny preferred working alone to avoid conflict, illustrating his theory that an artist must control all aspects of the creative act, but he did allow collections of his fabrics, gowns, and accessories to be sold in a Paris boutique operated by Paul Poiret. His gowns were also available at Liberty of London and his shops in Paris, London, and New York.

### Personal Image and Acknowledgments

Throughout his life Fortuny maintained a striking figure, dressing in artistic combinations, even regional and ethnic dress. He married Henriette Negrin, an accomplished French seamstress who designed patterns for his garments. Together, they developed methods and practices in the atelier of their Palazzo Orfei residence. Driven by spirited curiosity rather than training as a couturier, Fortuny depended on ancient and regional styles that became the foundation of his modern and comfortable styles for women, costumes for the theater, and yardage for interiors.

In an atmosphere of antiquated splendor, Fortuny dressed Venice's artistic community at the turn of the century, where Americans and Europeans—including the actress Sarah Bernhardt, the dancer Isadora Duncan, and the poet Gabriele D'Annunzio—were among those who sought cultural legitimacy with the notion that the classical and the beautiful were one. Artists of the theater and American travelers were the first to wear his gowns in public.

### Artistic Hallmarks

Among the garments viewed in museum collections, the loosely twisted, pleated gowns labeled Delphos and Peplos, of Greek origin, are exhibited more frequently than any others. His diagrams of the Delphos and the wooden structure fitted with ceramic tubes that heat-set his signature pleats are also popular museum exhibits. Similar avant-garde dresses, referred to as tea gowns, enhanced Fortuny's popularity with the wave of orientalism that dominated the arts in the years before World War I.

Echoing his knowledge of textile history, Fortuny produced his imaginative manipulations through printed and applied methods, freeing him to experiment. His vertical pleating and undulating silk and cotton yardage yielded natural elasticity, flowing effortlessly over the contours of female forms. Delicate Murano glass beads were laced onto silk cording and hand-stitched along hems, seams, and necklines, giving weight to an even edge, similar to the ancient Greek method of weighting fabric with metal. His method was to piece-dye cut lengths, frequently layering natural and, later, aniline dyes and occasionally incorporating agents to resist previously applied colors, which resulted in random, transparent irregularity. Clients were required to return the garment to the island factory of La Giudecca in order to clean and pleat the material.



For his imported silk, cotton, and velvet surfaces, Fortuny studied Japanese and Southeast Asian methods of hand-printing, including the *pochoir* method, for precise color transfer to cloth. Block printing and silk screening, positioned on seams in central areas of a garment and along edges, provided striking effects. Fortuny combined metal powder with pigments to simulate shimmering metallic thread, inspired by sixteenth-century velvets. On occasion, more than a dozen processes—including paintbrushes, sponges, and decolorization—were implemented on each unique length. The paintbrushes and sponges were used to create a marbled effect, already a method known in Lyon, to create the same effect of patchiness. Artisans were directed to incorporate various methods to correct or retouch the yardage. Textile patterns and motifs reflected his studies in the art museums of Venice, where he made note of the dress depicted in canvases. When he adapted the traditional practice of goffering, realizing a relief in velvet pile, he may have used block-printing methods and silk screening. His pattern adaptations of regional dress, hand-stitched with one of three labels (Mariano Fortuny Venise, Fabriqu  en Italie, or Fortuny de Pose), can be identified as variations inspired by ancient Greek dress for men or women, dress of the Renaissance and the Middle Ages, the Moroccan djellaba, North African *bournous*, Arabic *abaia* (a kind of caftan), Japanese kimono, Coptic tunic, and Indian sari.

### Fortuny in the Twenty-first Century

In 1922 Fortuny, Inc., was established in collaboration with the American interior designer Elsie Lee McNeill, later Countess Gozzi. Henriette remained in the palazzo to oversee the production of silk and velvet garments, while Fortuny moved production to a factory on the island of La Giudecca. After his death in 1949, garments were no longer produced. Gozzi continued to promote the mysteries of his textiles for almost forty years, until she sold her rights to printing yardage to her friend and attorney, Maged Riad, in 1998. In the early twenty-first century, Riad's children became responsible for the firm in New York, and his brother took over as the artistic director of production on La Giudecca. Appointments for research in the Palazzo Fortuny are limited, though the building is frequently the venue for art exhibitions, managed by the city of Venice.

The company's contemporary collection of yardage contains approximately 260 original patterns and color combinations printed on silk, velvet, and Egyptian cotton, including irregular application by artisans, who give each length an aged and artistic patina. Antique textile dealers and international specialists represent original yardage.

Since Fortuny creations were originally an attraction for travelers, interpretations of his artistry have been faithfully recovered by Venetia Studium, directed by Lino Lando and available to the visitor to Venice. Connois-

seurs, collectors, historians, and antique dealers agree that Mariano Fortuny achieved an elegant, impressive balance, fusing art and science. His legacy proves his relevance.

See also **Art and Fashion; Clothing, Costume, and Dress; Orientalism; Proust, Marcel.**

### BIBLIOGRAPHY

Deschodt, Anne-Marie, and Doretta Davanzo Poli. *Fortuny*. Translated by Anthony Roberts. New York: Harry N. Abrams, 2001.

D'Oasma, Guillermo. *Fortuny: Mario Fortuny, His Life and Work*. New York: Rizzoli International, 1980.

Fortuny, Mariano. *Fortuny*. New York: Fashion Institute of Technology, 1981. Published in conjunction with the exhibition *Fortuny*, shown at the Fashion Institute of Technology and the Art Institute of Chicago.

Fuso, Silvio. "Fortuny the Magician." *FMR* 120 (February/March 2003).

Steele, Valerie. *Paris Fashion: A Cultural History*. 2nd rev. ed. New York: Berg, 1998.

*Gillion Carrara*

**FULLING** Fulling, or milling, is a finish that produces a wool fabric softer, denser, heavier, and thicker than greige goods (fabric from the loom). Wool greige goods are reedy (loosely woven). Because fulled fabric is more compact, it has better cover and appearance. The fabric is shrunk under controlled conditions to make it compact. Shrinkage may be by as much as 50 percent, and it must be controlled or the fabric will become hard and harsh. Almost all wool woven fabric will be fulled to some degree; many knit fabrics will also be fulled. The amount of fulling will depend on the characteristics of the finished fabric.

Woolen fabrics, made from yarns with fibers that have been only carded are often heavily fulled. Carding and combing are yarn processes. Carding aligns the fibers somewhat where combing further aligns the fibers before spinning. Combed yarns have longer staple fibers and fewer fiber ends than carded yarns. Melton cloth is an example of fabric of such considerable fulling as to have a feltlike texture. Melton cloth is so heavily fulled that the warp and filling yarns are not seen. The fabric is smooth with a very short nap. Napping is a finishing process where the fiber ends are brushed to the surface of the fabric, producing a softer fabric. Melton and loden cloth are used for cold weather coating. Other fabrics that are heavily fulled are duffel—which is used in overcoats and blankets—kersey, and boiled wool. Boiled wool is not actually boiled but heavily fulled.

Worsted fabrics, made from yarns in which the fibers have been carded and combed, are lightly fulled. Since worsteds are firmly woven, they tend not to shrink as easily as loosely woven fabrics. The fibers in worsteds are less mobile and thus are unable to interlock as easily as soft, fluffy fabrics. Knitted sweaters are also lightly fulled.

### The Process

The fulling process takes advantage of the microstructure of wool fabric. The outer layer of the wool fiber consists of overlocking scales that can be seen under a microscope. The scales on the surface of the fiber point toward the tip and will move only in one direction. In the presence of moisture, heat, and friction, these scales will open up, move, and become interlocked. Once these scales interlock, the change is permanent and the fabric shrinks and thus becomes more compact.

The wool fabric is scoured to remove any processing oils that may be on the fabric. Then the fabric is placed in a rotary fulling or jig machine. The fabric is passed between stainless steel rollers pounded by clappers. Water with a mild alkaline soap and sodium carbonate or a weak acid dampens the fabric. Wool fibers need moisture, mechanical action, and heat for the scales on the fibers to interlock, and the friction from the pounding produces the necessary heat.

The fabric is carefully dried after the fulling process. To give it additional softness, the fabric may be brushed or napped.

See also **Wool**.

### BIBLIOGRAPHY

- Carty, Peter, and Michael S. Byrne. *The Chemical and Mechanical Finishing of Textile Materials*. Newcastle upon Tyne, U.K.: Newcastle upon Tyne Polytechnic Products, 1987.
- Slade, Philip E. *Handbook of Fiber Finish Technology*. New York: Marcel Dekker, 1998.

*Robyne Williams*

**FUR** Fur garments occupy a long and significant place in European history. From the fourteenth to seventeenth century, the kings and queens of England, for example, issued royal proclamations in order to regulate furs and fur apparel and, especially, to reserve the more exclusive furs of marten, fox, gray squirrel, and ermine for the aristocratic and clerical elite. These royal proclamations became part of what is known as “sumptuary legislation” in which everyday practices involving clothing, drinking, and eating were subject to public governance and scrutiny. Thus, from very early on furs and fur garments were regulated, not only in order to establish a hierarchy of desirable fur, but also to create recognizable codes of social status in the wearer of fur. While by law the most exclusive furs were reserved for the higher nobility, the middle class wore less costly furs such as beaver, otter, hare, and fox, and the peasantry wore the hardier, rougher furs of wolf, goat, and sheepskin.

Very little appears to have changed in six hundred years. In the global economy of the twenty-first century, the luxurious full-length fur coat is subject to various processes of identification, as a commodity and sign of elite standing and material wealth from England to Japan.

What is markedly different at the turn of the twenty-first century, is that fur garments, especially those worn by women, now come under intense scrutiny for the dangers and risks they pose to the planet’s ecological stability. Politics and fur fashions have become so intertwined in the contemporary setting that it is impossible to discuss fur fashions without reference to ecological struggles, not to mention the challenges faced by indigenous peoples in Canada, Greenland, and Alaska whose very livelihood, in some cases, still depends on the fur trade initially created by Europe’s early modern industrial economy and mercantile trade.

### Class, Gender, and Sex Distinctions

In the Middle Ages the exclusivity of some furs meant that they were used sparingly. The practice of “purfling” was invented in which the more expensive furs were reserved for decorative trim, while cheaper furs were used to finish the lining. There are some examples of excessive expenditures on the part of nobles such as Charles VI of France who apparently used 20,000 squirrel pelts to line a garment. It was not until the fur trade was established in the sixteenth century between France, and then England, and the New World (what is now Canada), that furs were available to European consumers in newer and larger supplies. Beaver fur was especially important to this new trade initiative and, in fact, became the primary economic unit from the mid-sixteenth century to the 1870s. In England, the technologically innovative process of felting beaver fur was used to produce the broad-brimmed beaver hats worn by the opposing religious and political groups of the seventeenth century, the Puritans and Cavaliers. One of the most significant promoters of the cavalier style of beaver hat was Charles II. With his restoration to the throne in 1660, the beaver hat emerged as a dominant fashion article supported no less than by Charles II’s incorporation of the Hudson’s Bay Company by royal charter. Thus, the English fur trade was firmly established and once again fur circulated in abundance among the nobility as well as among a rising mercantile class of consumers as a distinctive sign of class and imperial wealth.

In Russia, similar motivations to expand colonial governance and mercantile wealth were carried out through fur trading. From the mid-eighteenth century and throughout the nineteenth century, Russian frontier merchants traded in sea otter pelts from northern Pacific waters to fulfill the clothing demands of the Chinese elite. Competition from China and eventually the United States and Britain led to various economic and territorial accommodations that resulted in a treaty with the United States and the formation of the Russian-American company in 1824, and between the latter and the Hudson’s Bay Company in 1839.

The history of the fur trade and fur garments is in many ways a history of imperial class distinctions but one that is also marked by gender and cultural differences.

Influenced by the Russian fur market, in the earlier period in England the fur coat was worn both by men and women. The fur was mostly on the inside, visible as trim on the collar and cuffs. But during the late nineteenth century and throughout the twentieth century, fur became increasingly identified with elite women's fashions and the fur coat was "reversed" in the sense that fur was now worn almost exclusively on the outside.

The 1920s saw the image of the fur-clad woman emerge as a sign of unevenly distributed economic wealth. From debates in the British House of Commons in February of 1926 over the benefits of socialism in providing women with practical and affordable cloth coats against the excesses of capitalism represented by a luxury fur coat, to G. W. Pabst's brilliant silent film *Joyless Streets* (*Die Freudlose Gasse*, 1925) in which Greta Garbo plays the heroine who is offered a fur coat in exchange for her sexual services, the image of the fur-clad bourgeois woman not only signified material wealth; it also came to represent, in contradictory fashion, feminine passivity and female sexual power.

### Political Protests and Fur Fashion Design

The symbolic power associated with the fur garment in the Middle Ages ensured its value for contemporary fashion as a mark of distinction in the making of luxury commodities. Since the late nineteenth century and the publication of Leopold von Sacher-Masoch's novel, *Venus in Furs*, the fur coat's value increased with its strong identification with sexual fetishism. However, by the 1970s the fur coat was transformed from desirable female commodity to a symbol for animal rights' activism. Efforts to ensure that the international trade in specimens of wild animals, including fur by-products, did not threaten their survival resulted in the national and international legislation of the Endangered Species Act (1973) in the United States and the Convention on International Trade in Endangered Species of Wild Fauna and Flora (1975). The antisealing campaigns off the coast of Labrador in Canada in the 1970s anticipated the antifur protests of the 1980s and 1990s, headed by organizations such as People for the Ethical Treatment of Animals (PETA) in the United States and LYNX in England, which were successful, momentarily, in diminishing fur sales. More recently, the European Union tried to introduce a ban on the import of wild fur from countries using the leg-hold trap. The ban was temporarily postponed pending an international agreement on humane trapping standards among Canada, the United States, Russia, and the European Union. In response to the global politicization of fur garments, fur manufacturers developed new dyeing and tailoring techniques in order to change the conventional image of the elite fur-clad woman as well as to "disguise" fur, although the Federal Fur Products Labeling Act requires that all fur products bear a label indicating, among other things, whether the fur product was artificially colored. The fashion for fur knitting, popularized in the 1960s, was rejuvenated as a



### INUIT DRESS AND SOCIAL CLASS

Inuit now use combinations of traditional and southern-style garments to convey group affiliation, gender, age, role, status, social organization, interaction with neighboring groups, and changing technology. . . . Contemporary Inuit clothing provides an intriguing unwritten essay reflecting the social, economic, and technological changes to which Inuit have adapted over the last generation.

Judy Hall, Jill Oakes, and Sally Qimmiu'naaq Webster, eds., *Sanatujut, Pride in Women's Work: Copper and Caribou Inuit Clothing Traditions*.

result of these new design strategies. The synthetic textile manufacturers benefited from the antifur media campaigns and developed "fake fur" alternatives. In an interesting twist on the environmental implications of natural fur products, the Montréal-based fashion designer Mariouche Gagné recycled fur into fashion accessories, arguing that fur was a biodegradable product and, therefore, more ecologically friendly than the synthetic alternatives offered by the "green" marketplace.

In the early 1990s more established fashion designers such as Jean Paul Gaultier and Isaac Mizrahi tried to give their turn on fur fashion an edge of political correctness by creating designs that incorporated Inuit and First Nations motifs and images. First Nations and Inuit communities responded to this politics of appropriation, as well as to the economic devastation of their participation in the contemporary fur trade, by forming their own political organizations, for example, Indigenous Survival International. They also made use of public institutions—the British Museum in London, and the Canadian Museum of Civilization in Ottawa—to exhibit traditional as well as contemporary fur fashions in an effort to educate the general public about the symbolic and practical dimensions of fur in northern societies and economies.

See also **Muffs**.

### BIBLIOGRAPHY

- Emberley, Julia. *The Cultural Politics of Fur*. Ithaca, N.Y.: Cornell University Press, 1997. Comprehensive historical and cultural overview of the history of fur and fashion.
- Hall, Judy, Jill Oakes, and Sally Qimmiu'naaq Webster, eds., *Sanatujut, Pride in Women's Work: Copper and Caribou Inuit Clothing Traditions*. Hull, Quebec: Canadian Museum of Civilization, 1994. Excellent book on fur, clothing, and Inuit culture and society.
- Pelts: Politics of the Fur Trade*. Dir. Nigel Markham. Videocassette. National Film Board of Canada, 1989. An example



of the environmental movement's critique of fur fashion industry.

Steele, Valerie. *Fetish: Fashion, Sex, and Power*. New York: Oxford University Press, 1996. Authoritative text on fetishism and fashion, including fur fetishes.

*Julia Emberley*

**FUTURE OF FASHION** Predicting the future of fashion can be as analytical as market research and statistical analysis allow, or as speculative as the predictions William Norwich of the *New York Times* received when in April 2003 he playfully asked the fashion world's favorite psychic the question, "Where is the future of fashion?" Attempts to influence the future of fashion—made at times by dress reformers, moralists, and social thinkers—have invariably had little effect. Actual influences on fashion have typically stemmed from changing technologies, political events, and the creativity of certain individuals.

The manufacturing of clothes has always been affected by technological advances. The sewing machine revolutionized the clothing industry in the nineteenth century, and zippers altered clothing construction when they were perfected for use in the 1930s. In the early 2000s, technological innovations in fabrics influence how designers think about clothing, with textiles being developed that have properties unheard of in natural fibers. The abilities of these high-tech fabrics to stretch to overwhelming sizes or change their structure according to temperatures inspire clothing designers and blur the lines between fashion and industrial design. The Italian firm *Corpo Nove* designed a shirt woven with titanium that reacts to shifts in temperature. Wrinkles in the fabric are released when the shirt is exposed to hot air. Another item from the firm is a nylon jacket with a cooling system. The changing face of communications is also influencing styles of the future. A nylon jacket, manufactured by *Industrial Clothing Design*, a venture of *Philips Electronics* and *Levi Strauss and Company*, features a "fully integrated communications and entertainment system" (Lupton, p. 153).

Designers are also looking at ways of incorporating clothing with other functions of daily life. The *C.P. Company* has produced jackets that transform into chairs, tents or sleeping mattresses. *Ixilab*, a Japanese firm, designed plastic shorts with a cushion in the rear that inflates for the wearer to have a place to sit. New ideas for multifunctional clothing are also coming from industrial designers. A class called *Weaving Material and Habitation* at Harvard's Graduate School of Design "has been experimenting with Lycra-spandex type materials that can stretch out to four times their original size. A poncho or sweater might expand into a 7-foot-by-4-foot tarp" (Stevenson, p. 28).

Throughout fashion history, shifts in styles have been attributed to political and historical events. America's war with Iraq has elicited reactions from fashion designers ranging from antiwar sentiments to militaristic overtones. Proponents of various political and social issues attempt to influence what people wear and how clothes are produced. Antifur organizations frequently disrupt fashions shows featuring animal fur. The exploitation of labor is another controversial issue. Some politically minded consumers boycott clothes produced in factories and countries considered to have unfair labor practices. For some designers, these issues resonate; Katharine Hamnett has said that her goal is "the hope of making clothing that is environmentally friendly" (Jones and Mair, p. 209).

Primarily the fashion designers, in their roles as creators, determine the course of fashion. As a result, clothing designers are often asked to look into the future. Over time, their ideas and themes relating to these predictions remain almost constant. In 1968, André Courrèges described the future of fashion: "Women have become liberated little by little through thought, work, and clothes. I cannot imagine that they will ever turn back. Perhaps they will continue to suffer occasionally to be beautiful, but more than ever they seek to be both beautiful and free" (*Fashion, Art, and Beauty*, p. 140). He might have said the same in the early 2000s.

In her 1982 book *Fashion 2001*, Lucille Khornak asked fashion designers to each select a garment that would reflect fashions in 2001, and she interviewed them about how fashions would change by 2001. Many of the predictions made were unlikely to be achieved in that short period: "Paco Rabonne predicts that the clothes of the future will be premolded, bound or welded—no longer will they be sewn" (Khornak, p. 7). Issey Miyake is one designer rethinking how to make clothes for the future. Miyake's *A-POC* (A Piece of Cloth) features knitted tubes of fabric with markings for an outfit. When purchased, the fabric is cut by the wearer to make different articles of clothing. But ideas such as these are beyond the realm of mainstream fashion in the early twenty-first century.

One of the ongoing influences on fashion is the shift in women's roles in society. Fashion designers look at these changes from various angles and possibilities: the approach of unisex or androgynous clothing; the working woman's wardrobe as compared with men's wear; or the validity of femininity now that women are supposedly equal. The result is a spectrum of styles that caters to a diverse group of women, yet retains many stereotypes. Fashion continues to represent female sexuality as both demure, with pleats and bows and flowing chiffon, and as aggressive, with leather, corsetry, and body-revealing shapes. This dichotomy was featured in a 20 July 2003 *New York Times Magazine* fashion editorial of "good girl/bad girl" clothing.

The human body plays as integral a role as the clothes for many fashion designers working in the early 2000s. The idea of clothing as a “second skin” is often discussed when designers speak of the future of clothing. This concept has yet to be achieved with the wearing of only body stockings, or as Jean Paul Gaultier predicted in 1982 that we “spray on a latex body suit” (Khornak, p. 62). Yet this idea of a second skin continues to interest Gaultier and other designers. For his Fall 2003 collection, Gaultier created patterned bodysuits, worn under clothes, including one outlining the body’s arteries. More often fashion designers attempt to mold the body into other shapes. While the concept differs little from bustles of the nineteenth century, the results found in the early twenty-first century differ greatly. As Walter van Beirendonck, the Belgian designer for Wild and Lethal Trash, said, “the body of the future will be different” (Lupton, p. 187).

How fashion designers will manifest their ideas depends partly on the changing structure of the fashion industry and the evolving needs, and demands, of consumers. There remains the ongoing question regarding the demise of French couture and the stimulus to fashion from street styles. In *The End of Fashion*, Teri Agins argues that street style, consumer demands, and profit making have changed and will continue to alter the fashion industry. “In today’s high-strung, competitive marketplace, those who will survive the end of fashion will reinvent themselves enough times and with enough flexibility and resources to anticipate, not manipulate, the twenty-first century customer” (Agins, p. 16). While Agins’s theories apply to the marketplace, fashion in the twenty-first century still belongs to the elusive world of luxury, status, sex, and glamour. While fashion is known to be fleeting, many predictions about its future are slow to arrive.

See also **Fashion, Historical Studies of; Fashion Designer; Fashion Industry; Gaultier, Jean-Paul; Miyake, Issey.**

#### BIBLIOGRAPHY

- Agins, Teri. *The End of Fashion*. New York: HarperCollins, 1999.
- Braddock, E. Sarah, and Marie O’Mahony. *Techno Textiles: Fabrics for Fashion and Design*. New York: Thames and Hudson, Inc., 1999. Reprint 2001.
- Breward, Christopher. *The Culture of Fashion*. Manchester, U.K.: Manchester University Press, 1995.
- Fashion, Art, and Beauty*. *Metropolitan Museum of Art Bulletin* 26, no. 3 (November 1967).
- Jones, Terry, and Avril Mair, eds. *Fashion Now*. Köln, Germany: Taschen, 2003.
- Khornak, Lucille. *Fashion 2001*. New York: Viking Press, 1982.
- Lupton, Ellen. *Skin: Surface, Substance + Design*. New York: Princeton Architectural Press, 2002.
- Norwich, William. “Change Your Life, Boost Your Aura.” *New York Times Magazine*, 27 April 2003, 63–67.
- . “The Mirror Has Two Faces.” *New York Times Magazine*, 20 July 2003, 48–54.

Stevenson, Seth. “Gimme Temporary Shelter.” *New York Times Magazine*, 18 May 2003, 26–30.

Donna Gbelerter

**FUTURIST FASHION, ITALIAN** Futurism in fashion is not limited to the artistic movement alone. The pervasive conceptual and visual influence of futurist art at the beginning of the twentieth century accounts for the fact that the term “futurism” continues to be applied—in the case of fashion to designs that are made from unorthodox materials, demonstrate new technologies and shapes, and display colorful dynamism. Futurism as a modernist movement was born on 20 February 1909 when Filippo Tommaso Marinetti published his manifesto “Manifeste du Futurisme” in the Paris daily *Le Figaro*. His aim was to extol the shock of the new (as cubism had done previously). However, whereas the provocation had previously been limited to museums or books, Marinetti wanted to extend it to social and political life. While futurist paintings mixed stylistic idioms from cubism and divisionism, its poetry, music, photography, film, and drama expanded along more abstract principles like speed, novelty, violence, technology, nationalism, and urbanity, which were often expressed according to prior formulated declarations. For fashion the programs were written by Giacomo Balla in the form of the “Futurist Manifesto of Men’s Clothing” of 1914, followed by his “The Anti-Neutral Clothing: Futurist Manifesto” of the same year; in 1920 the “Manifesto of Futurist Women’s Fashion” by Volt (pseudonym of Vincenzo Fanni); 1932 saw the “Manifesto to Change Men’s Fashion” by the brothers Ernesto and Ruggero Michahelles; then Marinetti collaborated with Enrico Prampolini and a couple of second-generation futurists on “Futurist Manifesto: The Italian Hat,” and in 1933 the “Futurist Manifesto: The Italian Tie” was formulated by Renato di Bosso and Ignazio Scuroto.

The trajectory of these various programs can be constructed parallel to changes in futurist art from the avant-garde protest of its first generation, through the drama of World War I and sobriety of the time after the conflict, and the decorative subjectivism of the interwar years, to the rise in nationalist culture that would lead to the close association in the early 1930s between futurism and fascist Italy. The manifestos about fashion accordingly move from the direct intervention into culture by transforming the appearance of man—and to a lesser extent woman—in the street, where it was hoped that manners and mores would follow radical alterations in the bourgeois dress code, via a utilitarian attitude to dress as expression of communal principles, and the design of decorative and colorful costumes, to the fervent declaration of a nationalist dress. These various attitudes are not dissimilar to those that other art movements displayed vis-à-vis fashion, for example, aesthetic dress in Vienna or Proletkult clothing in 1920s U.S.S.R. Only futurism, however, ran through the entire range of oppositional

clothing, from radical individualism to collective uniform, from decadent subjectivity of sartorial expression to formal invention in the construction of clothes.

Despite the founding role of poetry (with its onomatopoeic “parole in libertà”) futurist aesthetics were disseminated markedly through painting. This implies a leaning toward decorative rather than structural solutions. And it favors the alteration of visual appearances and style (artistic, mode of living) rather than changing the sociopolitical foundation of artistic production proper. Similarly, fashion in futurism was often conceived as decorated surfaces of fabrics and textiles, where the introduction of color functioned as a novel element. An actual change in the cut and construction of clothes was comparatively rare.

From its very beginning futurism had a strong performative quality. Through the primacy of speed and dynamics, the representation of objects in movement became paramount. This was demonstrated not only through actual performances—although the poetry readings, musical soirées, and theater pieces, as well as demonstrative excursion in the motorcar, initiated an early concept of “performance art.” Significantly, futurist photographs and canvases aimed at showing successive stages of an object moving through space. This in turn accounts for the early significance of fashion, as an aesthetic expression that is directly—and almost exclusively—applicable to the active and activated body. Futurists like Balla and Fortunato Depero, who both designed costumes for the Ballets Russes in Paris, realized the opportunity of playing with volumes, density of material, and animated objects. Balla’s early designs between 1912 and 1914 show the attempt to break the surface of the body into fractions and lend movement to even heavy and static cloth. He hoped that the painted “speedlines” and colorful beams on the fabric would render even the most conservative and immovable individual a model of dynamism. Balla himself sported his designs well into the 1930s and conceived a rapid manner of walking and moving appropriate for the aesthetic principles of his dress. In contrast Marinetti, Depero, and others favored more staid sartorial expressions, wherein brightly colored waistcoats or ties offered the habitual outlet for individualism (1920s). Whereas men’s bourgeois suits, as the somber constructed mainstay of modernity, offered the most obvious target for a futurist reform of the dress-code, women’s fashion with its seasonal changes and decorated surfaces did not appear to require the same reformist zeal. Thus the futurist contribution to female dress is to be found outside Italy, in the “simultaneous” dresses by Sonia Delaunay created in Paris in the 1920s and the cubo-futurist costumes by Alexandra Exter and Liubov Popova made in Moscow from 1915 onward.

Balla had attempted to provide new patterns for the cut of shirts and suits that were based on geometric principles of nonobjective paintings, but it took Ernesto Michahelles, who worked under the pseudonym Thayaht,

to innovate a utilitarian and unisex dress that was based on the progressive notion that form and volume were to follow only inherent constructive principles. His “Tuta” of 1918 was designed as a cheap and uniform overall that due to its simple pattern could be tailored at home from a variety of fabrics. The aim was to provide “sportswear” that maximized freedom of movement for the body and directed an active lifestyle and corporeal ideal that would feed later into the fascist glorification of athleticism. In the early 2000s “tuta” is used in Italy to denote a track-suit and Thayaht, who went on to illustrate haute couture for Madeleine Vionnet, thus designed a template for the emancipation of the body in the time between the wars. More decorative solutions for the embellishment of dress came from Depero, whose contribution lies in the commercial viability of his designs for fashion boutiques, posters, and the theater, from Tullio Crali who continued Balla’s efforts to redesign the jacket and suit, and from Pippo Rizzo’s textiles.

Balla’s first Manifesto of 1914 had proclaimed: “We must invent futurist clothes, hap-hap-hap-hap-happy clothes, daring clothes with brilliant colors and dynamic lines. They must be simple, and above all they must be made to last for a short time only in order to encourage industrial activity and to provide constant and novel enjoyment for our bodies.” It was a sartorial call to arms that mixed progressive aesthetics in dress with a shrewd understanding of its commercial and industrial basis, thus perfectly fitting as a credo for the artist engaging in modernity.

See also **Art and Fashion; Theatrical Costume.**

#### BIBLIOGRAPHY

- Balla, Giacomo. “Futurist Manifesto of Men’s Clothing.” In *Futurist Manifestos*. Edited by Umberto Apollonio. London: Thames and Hudson, Inc., 1973.
- Crispolti, Enrico. *Il Futurismo e la moda*. Venice: Marsilio, 1986.
- Fiorentini Capitani, Aurora. “Tra arte e moda.” *Imago Moda* no. 1, Florence 1989.
- Hulten, Pontus, ed. *Futurism & Futurisms*. London: Thames and Hudson, Inc., 1987.
- Lapini, Lia, ed. *Abiti e costumi futuristi*. Pistoia, Italy: Edizioni del Comune, 1985.
- Lista, Giovanni. *Balla*. Modena, Italy: Galleria Fonte d’Abisso, 1982.
- . “La Mode Futuriste.” In *Europe 1910–1939*. Edited by Valérie Guillaume. Paris: Les Musées de la Ville de Paris, 1996.
- Ruta, Anna-Maria. *Arredati Futuristi*. Palermo, Italy: Il labirinto, 1985.
- Scudiero, Maurizio. *Fortunato Depero*. Trento, Italy: Il Castello, 1995.
- Stern, Radu. *Against Fashion*. Cambridge, Mass., and London: MIT Press, 2003.

Ulrich Lehmann





**G-STRING AND THONG** The G-string, or thong, a panty front with a half- to one-inch strip of fabric at the back that sits between the buttocks, became one of the most popular forms of female underwear in the early twenty-first century. Its sources are manifold; the thong bikini designed by Rudi Gernreich in 1974, launched with a matching Vidal Sassoon hairstyle, is one which in turn spawned the more popular Brazilian string bikini brief, or tanga, of the late 1970s. This tiny bikini—dubbed the *fio denta*, or dental floss—ensured that the buttocks achieved maximum exposure to the sun and openly displayed an erogenous zone that was a particular favorite in Latino culture.

The stripper's G-string is another influence and has been an important part of the striptease artist's—or, more latterly, lap dancer's—wardrobe since the 1950s, when the taboo of displaying the vagina or any degree of pubic hair was paramount. The G-string was comprised of an elastic string that went around the waist and up between the buttocks and is popularly believed to have been originally added to the stripper's accoutrements on the occasion of the 1939 World's Fair in New York when Mayor Fiorello La Guardia demanded that the city's nude dancers cover themselves as a mark of respect for the thousands of visitors thronging the city. However, these types of coverings could be described as derivations of male underwear or garments associated with sports, such as jockstraps, which tend to reveal the muscle power of the legs and buttocks. Posing pouches worn by nude models in life classes since the Renaissance and in the nineteenth and early twentieth century in magazines promoting "health culture" and featuring body builders could be seen as types of G-string in that they have a front part that covers the genitals and a string at the back that exposes the bottom.

The thong was incorporated into the vocabulary of women's underwear in the 1980s in response to tighter and tighter trousers, especially jeans worn by women to display more of their gym-honed bodies in an era that emphasized muscled body shape. Women demanded underwear that would remain invisible under outerwear and combat what became known as VPL, or Visible Panty Line. Frederick Mellinger, of popular underwear manufacturer Frederick's of Hollywood, realized the potential

of this form of underwear; Frederick's began to mass-market the thong, at first known as the "scanty panty," as an erotic item alongside crotchless or edible underwear. By the mid-1980s, however, the thong began to be appreciated as a practical garment in its own right. By 2003, it had become the fastest growing segment of women's underwear, making "full-bottomed" panties almost obsolete. In order to persuade the few reluctant women left to wear the thong, a "training" garment was invented called the Rio, or "starter" thong, which rose more sedately up the sides to expose less of the buttocks.

In the 1990s, the thong became a garment of folkloric proportions after the White House intern Monica Lewinsky's affair with U.S. president Bill Clinton was outlined in the Starr Report. Lewinsky admitted initiating her liaison with Clinton by flirtatiously lifting the back of her formal suit jacket to reveal the straps of her thong underwear. This indicated the irony of the thong for, in its original incarnation as underwear, it was designed to remain invisible so as to reveal the contours of a shapely bottom under the tightest of trousers. By the early 2000s, it became fashionable to wear low-cut hipster jeans that revealed the back of the thong, which became a focal point reinforced by diamanté-covered straps by such designers as Agent Provocateur and Frost French and the manufacturers Gossard. This fad, believed to be initiated by glamour model Jordan in England and singers Britney Spears and Mariah Carey in the United States, also showed a cultural shift in the sexual zoning of women's bodies. The prominent, fleshy bottom mythologized in African American culture by songs such as "The Thong Song" by American rhythm and blues star Sisqó, who exhorted, "Let me see that thong," and eulogized in the shape of actress and singer Jennifer Lopez, began to take over from the breasts as the primary erogenous zone. The popularity of the thong spread across all ages and sexes (although the man in the thong is mainly popular in certain gay circles), and by 2003, a moral panic had ensued as parents and the media saw the thong as responsible for sexualizing girls at too young an age. According to provisional figures compiled by manufacturers' sales of thongs to *tweenage* girls, the marketing definition of twelve- to fourteen-year-olds, jumped 33 percent from 2002 to 2003 in the United Kingdom. In 2003, an estimated ten million thongs worth about sixty-five million

pounds were sold in the United Kingdom. The British shop Tammy Girl came under particular fire for marketing thongs to pre-teenaged girls with logos such as “Cupid Rules” and “Talent” printed on them. A further attack on the thong came in 2002, when the authorities at Daytona Beach, Florida, using anti-nudity laws to dissuade the use of the thong, threatened to arrest anyone displaying more than a third of their buttocks in public.

See also **Lingerie; Underwear.**

#### BIBLIOGRAPHY

Cox, Caroline. *Lingerie: A Lexicon of Style*. London: Scriptum Editions, 2001.

Craik, Jennifer. *The Face of Fashion: Cultural Studies in Fashion*. London: Routledge, 1994.

Caroline Cox

**GABARDINE** Gabardine is a tightly woven warp-faced twill weave fabric. Warp-faced fabrics have more warp or lengthwise yarns on the surface of the fabric than filling or crosswise yarns. Twill weave fabrics show a diagonal wale, or raised line, on their surface. The fine wale is closely spaced, slightly raised, distinct, and obvious only on the fabric’s face. The wale angle in gabardine is 45 or 63 degrees. Gabardine always has many more warp than filling yarns, often twice as many warp yarns as filling yarns. Fabric weights range from 7 ounces per square yard to 11 ounces per square yard. Fabric density ranges from 76 warp ends per inch (epi) by 48 filling picks per inch (ppi) to 124 epi by 76 ppi. The combination of the weave structure, yarn size, and warp to filling ratio creates the wale angle. A steep (63 degree angle) twill gabardine is often used in men’s wear while a regular (45 degree angle) twill gabardine is often used in women’s wear. In the most common interlacing patterns the warp crosses two filling yarns before going under one filling (2 x 1) or the warp crosses two fillings before going under two fillings (2 x 2) to create right-hand twills in which the wale line moves from the lower left to the upper right.

Gabardine is a firm and durable fabric with a hard or clear finish. Singeing and shearing remove projecting surface fibers, fuzz, and nap and make the yarn and weave structure visible. Gabardine is available in several fiber types, weights, and qualities. Gabardine is usually made of wool. The best-quality gabardine uses two-ply worsted yarns, but single-worsted yarns, two-ply, and single woolen yarns are also used. Better quality fabrics are soft with a beautiful drape. Lower-quality fabrics are harsh, rough, and stiff. Two-ply worsted yarns, the warp-faced structure, and the fabric’s hard finish produce a long-wearing and durable fabric. Gabardine is found in medium (dress) to heavy (suiting) weights in all wools, wool and synthetic blends, and acrylics. Gabardines made of cotton or silk are strong, compact, and elegant, but not very common. Gabardine can also be 100 percent



#### GLOSSARY OF TECHNICAL TERMS

**2 x 1; 2 x 2:** The number of filling yarns crossed over by the warp is represented by the first digit. The number of filling yarns the warp passes under before returning to cross the filling again is represented by the second digit.

**Filling picks:** Textile industry term for a crosswise yarn in a woven fabric.

**Right-hand twill:** Twill weave fabrics in which the wale line moves from lower left to upper right.

**Wale:** A raised line visible on the face of the fabric.

**Warp-faced:** Fabric in which the lengthwise (warp) yarns predominate on the surface of the fabric.

**Warp yarns:** Lengthwise yarns in a woven fabric.

textured polyester or a cotton-polyester blend. Cotton and textured polyester gabardines are usually made with a left-hand 2 x 2 twill weave.

Gabardine has a dull sheen. It is usually piece dyed for solid color fabric. It also may be fiber (stock) dyed for heather fabrics or yarn dyed for stripe or plaid fabrics. Because of its compact structure and hard finish, it sheds soil and water and does not wrinkle easily. It works best with tailored designs that have clean and simple lines or gentle curves because the tight weave makes easing in large quantities of fabric difficult. Gabardine is used for such apparel as slacks, jackets, and suits for men and women, uniforms, skirts, raincoats and all-weather coats, sportswear, riding habits, skiwear, hats, and fabric shoes. Lighter-weight gabardine is used for sportswear and dresses while heavier-weight gabardine is used for slacks and more tailored suits. Excessive wear or overworking when ironing or pressing may produce a shine on the fabric.

An alternate spelling is gaberline. Gabardine is Spanish or French in origin. In the Middle Ages, gabardine described a loose mantle or cloak of a coarse woven twill.

See also **Weave, Twill.**

#### BIBLIOGRAPHY

Humphries, Mary. *Fabric Glossary*. Upper Saddle River, N.J.: Prentice Hall, 1996.

Parker, Julie. *All About Wool: A Fabric Dictionary and Swatchbook*. Seattle, Wash.: Rain City Publishing, 1996.

Tortora, Phyllis G., and Robert S. Merkel. *Fairchild’s Dictionary of Textiles*. 7th ed. New York: Fairchild Publications, 1996.

Sara J. Kadolph

**GALANOS, JAMES** Often hailed as one of the few American designers to rival the great French couturiers in craftsmanship and exquisite finish, James Galanos achieved his position as one of America's premier designers through his commitment to exquisite fabrics and perfect workmanship throughout his long career. An uncompromising individualist, he established Galanos Originals in Los Angeles rather than New York's Seventh Avenue and went on to create a successful ready-to-wear business, catering to a discerning clientele.

Galanos was born in 1924 in Philadelphia, the third child and only son of émigrés from Greece. He knew at a young age that he wanted to design dresses and was fortunate to have the support of his family throughout his early struggling career. After graduation from high school in 1942, Galanos enrolled at the Traphagen School of Fashion, one of the oldest schools of its kind in New York City. He lasted only two semesters, having grown bored with the curriculum despite coursework that included design, draping, and construction. Hoping to gain actual design experience, Galanos took a job at the firm of Hattie Carnegie. This turned out to be another disappointment, so he left and began selling his sketches to ready-to-wear firms on Seventh Avenue, with limited success.

Galanos's acquaintance with the entrepreneur Lawrence Lesavoy led to his relocation to Los Angeles in 1946. After his failed business venture with Lesavoy left him unemployed, he made sketches for Columbia Pictures' head designer Jean Louis. Lesavoy compensated Galanos a year later by offering to underwrite his study and travels in Europe. In 1947 Galanos went to Paris, where he secured a position as apprentice designer at the House of Robert Piguet. Galanos stayed for just one year, yet the lessons in French fabrics and couture construction he learned at Piguet had a lasting impact on his later career.

### Galanos Originals

Galanos returned to New York in 1948 and accepted a design position with another Seventh Avenue dressmaking firm, Davidow, but the venture was unsuccessful, and Galanos headed back to California. With the encouragement and financial backing of his former employer Jean Louis, Galanos designed a line of dresses, which was purchased by the Beverly Hills buyer for Saks Fifth Avenue, and thus Galanos Originals was launched in 1951.

From the start Galanos garments were unique. Although they were ready-to-wear garments, Galanos Originals included many features more commonly associated with custom dressmaking—hand embroidery, beadwork, rolled hems, tucking, piping, and luxurious fabrics. Integrally involved with all aspects of production, Galanos continued to run his design business through the years. Even into the twenty-first century he traveled twice a year to Europe, where he selected fabrics. He also designed the collection, consulted with technical assistants, oversaw the workroom, and had a hand in marketing the lines.



**James Galanos altering a dress.** Trademarks of Galanos's ready-to-wear collection include expensive, luxurious fabrics and meticulous details more often found in custom dressmaking. © BETTMANN/CORBIS. REPRODUCED BY PERMISSION.

Galanos designs range from meticulous day wear to exquisite evening dresses, but all feature fabrics of exceptional quality. His perfectly cut suits and day dresses, fashioned from expensive wools, silks, cottons, and linens, featuring such fine detailing as welted seams and tucking that produce a sculptural quality akin to the designs of Cristóbal Balenciaga, one of Galanos's favorite designers. His simple wool dresses appear to be carved out of the fabric through virtuoso pleating. Galanos also has distinguished himself with his copious and accomplished use of chiffon throughout his design career. Pleating, draping, and *bouillonné* gathering are some of the labor-intensive hand techniques he has employed with this fabric. At times using up to fifty yards of chiffon in a skirt, Galanos has been credited with contributing to the post-war revival of the chiffon industry in France.

Galanos's evening dresses have emphasized finesse and luxury rather than innovation. During his career he explored many different silhouettes, including full, bell-shaped skirts and dropped-waist "ballerina" dresses in the 1950s, miniskirts and caftans in the 1960s and 1970s, and off-the-shoulder sheaths in the 1980s and 1990s. His trademark silhouette, however, is a columnar sheath shape, featuring wide shoulders and a long,



slim skirt. This simple, understated form offers the perfect foundation for another of Galanos's trademarks—exquisite embroidery. In the mid-twentieth century, Galanos began to collaborate with the Los Angeles firm of D. Getson Eastern Embroidery in the creation of intricate, hand-applied beadwork, sequins, and embroidery. This collaboration produced some of the most elaborate, labor-intensive ready-to-wear garments on the market.

Despite the modest size of his business, Galanos's adherence to quality and detail always ensured him a devoted fan base. Nancy Reagan, who became a client when her husband was governor of California, is perhaps his most famous customer. She wore Galanos gowns to four inaugural balls and countless receptions. Her selection of a fourteen-year-old Galanos gown for the presidential inauguration ball in 1981 highlighted the timelessness of his designs while bringing Galanos a new level of national attention formerly accorded only by the fashion connoisseurs.

From fashion critics Galanos has received almost every possible award. He won his first Coty American Fashion Critics Award in 1954, followed by awards from Neiman Marcus, Filene's, the Fashion Group, the *Sunday Times*, and the Council of Fashion Designers in America. Galanos designs are represented in the permanent collections of many major museums, and he has been the subject of retrospective exhibitions organized by such institutions as the Los Angeles County Museum of Art (in 1975), the Fashion Institute of Technology in New York (in 1976), the Smithsonian Institution, the Metropolitan Museum of Art, the Brooklyn Museum, the Philadelphia Museum of Art, Ohio State University, the Dallas Museum of Art, and the Western Reserve Historical Society in Cleveland, in collaboration with the Los Angeles County Museum of Art (in 1996).

Galanos is considered one of America's great designers. His independent vision, rigorous work ethic, and continued insistence on preserving the use of quality fabrics and thoughtful cut and construction in his garments made him a unique living link between the French couture tradition and American ready-to-wear.

See also **Ball Dress; Balenciaga, Cristóbal; Beads; Embroidery; Ready-to-Wear.**

#### BIBLIOGRAPHY

- Bradley, Barry W. *Galanos*. Cleveland, Ohio: Western Reserve Historical Society, 1996.
- Diamondstein, Barbaralee. *Fashion: The Inside Story*. New York: Rizzoli International, 1985.
- Millbank, Caroline Rennolds. *Couture: The Great Designers*. New York: Stewart, Tabori and Chang, 1985.
- Williams, Beryl. *Young Faces in Fashion*. Philadelphia: J. B. Lippincott Company, 1956.

Lauren Whitley

**GALLIANO, JOHN** John Galliano (1960–) is widely considered one of the most innovative and influential fashion designers of the early twenty-first century. Known for a relentless stream of historical and ethnic appropriations, he mingled his references in often surprising juxtapositions to create extravagant yet intricately engineered and meticulously tailored clothes. His continual interest in presenting fashion shows as highly theatricalized spectacles, with models as characters in a drama and clothes at times verging on costumes, won him applause as well as criticism. With his respective appointments at Givenchy and Christian Dior, Galliano rose to international celebrity status as the first British designer since Charles Frederick Worth to front a French couture house. He has been a member of France's *Chambre Syndicale de la Haute Couture* since 1993 and is the winner of many prestigious awards, most notably British Designer of the Year in 1987, 1994, 1995, and 1997, and International Designer of the Year in 1997.

#### Education and Early Career

Galliano, christened Juan Carlos Antonio, was born in Gibraltar in 1960. He moved to Streatham, South London, with his Gibraltar father and Spanish mother at the age of six. Galliano had a brief period of work experience with Tommy Nutter, the Savile Row tailor, during his studies at St. Martins School of Art in London (since renamed Central St. Martin's), as well as a part-time position as a dresser at the National Theatre. He graduated from St. Martins with first class honors in fashion design in 1984. His hugely successful final collection, *Les Incroyables*, was based on fashion motifs of the French Revolution and was immediately bought by the London boutique Browns, where it was featured in the entire window display. Galliano launched his label in the same year and has designed in his own name ever since.

Despite Galliano's rapid securing of a cult following and critical acclaim with such collections as *Afghanistan Repudiates Western Ideals*, *The Ludic Game*, *Fallen Angels*, or *Forgotten Innocents*, the business part of his early design career was most challenging. With inadequate and unstable financial backing—the Danish businessmen Johan Brun and Peder Bertelsen were among his first backers—Galliano had to produce several collections on a limited budget; some seasons he was not able to show at all. Galliano's shows of this period sometimes relied on last-minute improvisations for the final effect—as in his *Fallen Angels* show when he splashed buckets of cold water over the models just before the finale. Galliano began to work with the stylist Amanda Harlech, who worked closely with him until 1997. Other long-term associates include the DJ Jeremy Healy, the milliner Stephen Jones, and the shoemaker Manolo Blahnik.

In 1990 Galliano designed the costumes for Ashley Page's ballet *Currulao*, performed by the Rambert Dance Company. In 1991 he launched two less expensive, youth-oriented diffusion lines, Galliano's *Girl* and *Galliano*

Genes. By the early 1990s, Galliano had become firmly rooted in London's club scene. This, combined with his first-hand knowledge of the theater, channeled his interests toward experimentation and rarefied eccentricity, while it also fed the self-styled reinventions of his personal image. Both remain Galliano trademarks.

### From London to Paris

Galliano moved to Paris in 1990, hoping for better work prospects. His acclaimed 1994 spring–summer collection, inspired by his personalized fairy-tale version of Princess Lucretia's escape from Russia, opened with models rushing down the catwalk, tripping over their giant crinolines supported by collapsible telephone cables. Thanks to the support of (U.S.) *Vogue's* creative director Anna Wintour and the fashion editor Andre Leon Talley, Galliano's breakthrough 1994–1995 autumn–winter collection was staged in an *hôtel particulier*, the eighteenth-century mansion of the Portuguese socialite São Schlumberger. The show re-created the intimate mood of a couture salon, with models walking through different rooms in the house that held small groups of guests. The interior of the house was transformed into a film set, evoking an aura of romantic decadence, with unmade beds and rose petals scattered about. Despite being composed of a mere seventeen outfits, the show used choreography and its exotic location to mark a momentous mid-1990s shift toward fashion shows as spectacles. A comparable mode of presentation was developed by Martin Margiela and Alexander McQueen around the same time.

In 1995 the president of the French luxury conglomerate LVMH, Bernard Arnault, appointed Galliano as Hubert de Givenchy's replacement as principal designer at Givenchy. Here Galliano had an excellent opportunity to study the archives of a major Parisian couture house. He developed his skill for merging—within one collection or a single outfit—traditional feminine glamour with a distinctly contemporary element of playfulness. He was also able to do justice to the breadth of his vision as one of fashion's most spectacular showmen. During and after Galliano's brief tenure at Givenchy, the house acquired an air of "Cool Britannia," and received unparalleled publicity. Alexander McQueen took over at Givenchy in 1996, while Galliano was installed as chief designer at another LVMH label, Christian Dior, as Gianfranco Ferré's successor. Four years later, Galliano's creative control over Dior's clothes was extended to the house's accessories, shop design, and advertising. Meanwhile, Galliano has continued to design under his own label. In 2003 he opened his first flagship store on the corner of the rue Duphot and the rue du Faubourg-Saint Honoré in Paris. The building's interior was designed by the architect Jean-Michel Wilmotte. Galliano launched his first signature men's wear collection since 1986 for autumn–winter 2004.

Galliano creates eclectic clothes, which are based on sources from fashion, film, art, and popular culture, and



**John Galliano.** Bold and imaginative, Galliano often presents his fashion shows as highly theatrical affairs, with models playing characters and clothing inspired by historical costumes. AP/WIDE WORLD PHOTOS. REPRODUCED BY PERMISSION.

modernizes his borrowings to varying degrees. Inspired by extensive travel experiences as well as thorough research in libraries, museum exhibitions, and archives, Galliano interprets not only exotic and historical looks but also construction techniques—most significantly the body-flattering elastic bias cut popularized by Madeleine Vionnet in the 1920s. His approach has been described variously as magpie-like, history-book-plundering, romantic escapism, and postmodern pastiche. Galliano's first haute couture Dior collection for spring–summer 1997, which coincided with Dior's fiftieth anniversary, juxtaposed quasi-Masai jewelry and quasi-Dinka beaded corsets with hourglass silhouettes reminiscent of the Edwardian era and Dior's own New Look. In the same collection, innocent white leather doily-like dresses and hats were shown alongside 1920s Chinese-inspired dresses styled with a menacing edge.

Unlike the androgynous creatures who paraded avant-garde shapes in Galliano's London shows of the 1980s, the heroines of his 1990s Paris period were luxurious icy divas by day and exotic opium-fueled seductresses by night—as represented in his Haute Bohemia collection for spring–summer 1998. For most of the decade he found inspiration in mysterious and sexually ambiguous women, ranging from real historical aristocrats, showgirls, and actresses to imagined characters and female stereotypes: Indian princess Pocahontas, Lolita (stemming from Vladimir Nabokov's fictional character), Edwardian demimondaines, the actress Theda Bara as Cleopatra, the artist and model Kiki de Montparnasse, the Russian princess Anastasia Nicholaevna, the Duchess of Windsor, the film character Suzie Wong, other prostitutes, and trapeze artists. Galliano's real clients in this period included Béatrice de Rothschild, Madonna, Nicole Kidman, and Cate Blanchett.

Since around 2000, in addition to Galliano's multicultural cross-referencing, he has placed new emphasis on shaking up the high and low of fashion. He has returned to the excesses of his earlier work and “dirtied” traditional elegance with over-the-top chaotic mixes of punk and grunge trashiness, 1980s–1990s street culture, clown-like infantilism, and spoofs of “rock'n'roll chic.” While the designer maximized the concepts of couture and ready-to-wear alike as a masquerade and “laboratory of ideas,” with clothes as “showpieces,” he has reinforced the identities of Givenchy and particularly Dior as leading luxury brands with a tongue-in-cheek twist. The creative identity of his own label, which makes up for two of the six collections he produces yearly, has been closely linked to that of Dior.

See also **Blahnik, Manolo; Dior, Christian; Givenchy, Hubert de; Grunge; London Fashion; Margiela, Martin; McQueen, Alexander; Paris Fashion; Punk; Vionnet, Madeleine.**

#### BIBLIOGRAPHY

- Arnold, Rebecca. *Fashion, Desire and Anxiety: Image and Morality in the Twentieth Century*. London and New York: I. B. Tauris, 2001.
- Barley, Nick, Stephen Coates, Marcus Field, and Caroline Roux, eds. *Lost and Found: Critical Voices in New British Design*. Basel, Boston, and Berlin: Birkhäuser Verlag AG and The British Council, 1999.
- Bradberry, Grace. “From Streatham to Dior.” *The Times* (London), 15 October 1997.
- Breward, Christopher. *Fashion*. Oxford: Oxford University Press, 2003.
- Evans, Caroline. *Fashion at the Edge: Spectacle, Modernity, and Deathliness*. New Haven, Conn., and London: Yale University Press, 2003.
- Frankel, Susannah. *Visionaries: Interviews with Fashion Designers*. London: V and A Publications, 2001.
- McDowell, Colin. *Galliano*. London: Weidenfeld and Nicolson, 1997.

Menkes, Suzy. “Dior's Aggression Misses the New Romantic Beat.” *International Herald Tribune*, 10 October 2001.

Tucker, Andrew. *The London Fashion Book*. London: Thames and Hudson, Inc., 1998.

Marketa Ublirova

#### GARMENTS, INTERNATIONAL TRADE IN

Garments have been perhaps the most international of consumer products dating back to the late 1800s when Paris couturiers—led by the House of Worth—dictated the styles that affluent women around the world wore. Those garments were composed of rich, imported fabrics and trimmings: silks from China, woolens and velvets from England, damasks and lace from Italy. Back then, representatives from the first department stores in the United States, Chicago's Marshall Field's, R. H. Macy's in New York, and John Wanamaker in Philadelphia, voyaged to Paris in order to purchase haute couture samples, that their workrooms translated into styles suitable for America's growing consumer society.

In the 1980s, the fashion boom popularized designer jeans and athletic shoes and accelerated the globalization of fashion, as licensing became a lifeline to the fashion business, especially couture fashion houses. In fashion licensing, a design house collects a royalty payment between 3 percent to 10 percent of wholesale volume, from an outside manufacturer who produces and markets the merchandise. Licensing enabled designers to put their trademarks on clothes, handbags, jewelry, shoes, and perfume quickly and relatively painlessly. Licensing turned designers like Pierre Cardin and Calvin Klein into household names as they built billion dollar empires marketing sofas, bedsheets, clocks, and even frying pans to an international marketplace.

Modern fashion houses have no national borders. For example, an outfit that carries an Italian fashion label might have well been created in Milan, by a team of British, French, and American designers, and manufactured by contractors from countries in China, Korea, and Mexico.

This shift toward globalization is evident in trade statistics. In 1999, the five leading exporters of clothing were China (\$30.08 billion), Italy (\$11.78 billion), Hong Kong (\$9.57 billion), the United States (\$8.27 billion), and Germany (\$7.44 billion). The five largest importers of clothing were the United States (\$58.79 billion), Germany (\$20.77 billion), Japan (\$16.40 billion), the United Kingdom (\$12.53 billion), and France (\$11.58 billion). France, despite the continuing prominence of Paris in the world of fashion design, had only \$5.69 billion in clothing exports in 1999 (International Trade Centre, World Trade Organization, 2001).

Like McDonald's and Starbucks, fashion marketers have been forced to think globally in order to cater to a



cross section of international shoppers whom they now serve directly. No longer do consumers have to travel abroad to find the top brands, as Giorgio Armani, Valentino, and Polo Ralph Lauren have blanketed the world with boutiques from Buenos Aires to Tokyo.

Thanks to the Internet, Hollywood, and cable television, there is not much difference between consumers in Spain and those in the United States, who are all exposed to the same trends, celebrity role models, and popular music simultaneously. Furthermore, globalization has leveled the playing field, enabling retailers from the Gap to Zara to Target to compete in the multibillion-dollar fashion game, as these discount chains have learned to master the mechanics of delivering fast fashion at rock bottom prices.

Fashion entered a new era in the 1990s, as the world's buoyant high-tech industries broke the pattern for formal dress codes. Jeans, khakis, and knitwear replaced suits as the new corporate uniform. Seeking higher ground, the high fashion industry could no longer bank on dress-up clothes. Marketers thus found a new hook to captivate consumers: accessories like handbags, shoes, and watches, which could be plastered with showy designer logos and coordinated with casual clothes. Furthermore, accessories delivered higher profit margins than apparel, making them even more attractive to fashion marketers.

Luxury accessories thus became the focal point of such European conglomerates as Gucci, Prada, and LVMH Moët Hennessy Louis Vuitton, which scooped up dozens of faded fashion brands like Givenchy, Yves Saint Laurent, and Fendi. By owning a roster of fashion brands, these clothing giants have benefited from economies of scale. The luxury fashion boom began in the late 1990s as women began collecting status trinkets, the \$1,000 Fendi baguette handbags, for example, that they wore to dress up their casual clothes. The accessories boom underscored how international fashion trends have become as shoppers in Tokyo, Paris, and New York all flocked to buy the hot designer handbags of the season.

Industry experts agree the next frontier is the Internet, which takes globalization to new heights. With the click of a mouse from their laptop computers, the world's consumers can conveniently shop the shelves of Harrods in London, L.L. Bean in Maine, Neiman Marcus in Texas, as well as Ebay, the auction Web site that features fashion merchandise offered by millions of individuals from around the world.

More than anything, the Internet has exposed the world's consumers to an infinite range of choices at all price ranges. It is the ultimate example of globalization, built on the back of rapidly changing media, which has further democratized fashion, shrinking the world into a single, accessible marketplace.

See also **Fashion Industry; Globalization.**

#### BIBLIOGRAPHY

- Dickerson, Kitty G. *Textiles and Apparel in the Global Economy*. 3rd ed. Englewood Cliffs, N.J.: Prentice Hall, 1998.
- Hyvarinen, Antero. "The Changing Pattern of International Trade in Textiles and Clothing." Geneva: International Trade Centre, World Trade Organization, 2001.

*Teri Agins*

**GAULTIER, JEAN-PAUL** Jean-Paul Gaultier was born in 1952 in the Paris suburb of Arcueil. An autodidact, he discovered fashion at a very early age. In childhood and adolescence, television and fashion magazines fed his imagination; he was particularly fascinated by the fashion features in *Elle*. He served his apprenticeship as a designer from 1970 to 1975 in the most innovative couture houses of the time: Pierre Cardin, Jacques Esterel, Jean Patou, and Angelo Tarlazzi. He soon struck out on his own and presented his first show of women's fashion in 1976.

Noticed and financed at first by the Japanese consortium Kashiyama, Gaultier established his own business in 1982, the success of which was continuous into the early 2000s. He developed a men's fashion line in 1984 and attracted a broader clientele through his Junior Gaultier collections, replaced in 1994 by a new JPG line. In 1992 he introduced Gaultier Jean's creations, and accessories and perfumes completed the lightning-fast rise of his business. Gaultier's fashion consecration arrived with his first haute couture collection in 1997. Investment support from Maison Hermès in 1999 enabled him to increase his reputation and his distribution, notably with the establishment of a network of boutiques bearing his name.

A Parisian designer, Gaultier was deeply attached to his city, which provided the backdrop to his inspirations. Neighborhoods such as Pigalle and Saint-Germain, monuments like the Eiffel Tower and the Moulin Rouge, and the most emblematic Parisians, from Toulouse-Lautrec to Juliette Greco, fueled his imagination. In the tradition of Chanel and Saint Laurent, his clothing has made it possible for women to assert their independence in an emancipated city.

From the beginning of his fashion career, London was Gaultier's second city. It very early became an immense source of inspiration, with the punk and ska movements, the allure of James Bond, and especially the flea markets and the eccentricities of Londoners. He felt a deep and enthusiastic admiration for his elder, Vivienne Westwood. The street fascinated him, providing him with the means of attaching fashion to the present and amplifying the echoes of the world around him. He has reinterpreted and made his own uses of the wardrobe of the past and its legacy in order to provide clothing for the future.

The Gaultier style of the 1980s was identifiable by the famous silhouette of broad and sloping shoulders and



**Jean-Paul Gaultier and Vivienne Westwood.** Gaultier's eclectic and often controversial designs found acceptance in pop culture, and in 1990 he designed for Madonna's *Blonde Ambition* tour. AP/WIDE WORLD PHOTOS. REPRODUCED BY PERMISSION.

narrow hips that emphasized stockinged legs. In the 1990s his palette of colors and materials was enriched by contact with many cultural worlds. The silhouette became more balanced, and comfort and protection took on added importance. His shows, with their exuberant and provocative staging, long obscured the fact that his clothes are designed to be worn. At the beginning of the millennium, he attained a certain classicism without renouncing the original image of his talent as the enfant terrible of fashion.

Gaultier's work has been characterized by a stylistic consistency since 1976: jacket and pants constitute the basic link between male and female wardrobes. The masculinity of double-breasted jacket, fitted coat, leather jacket, overalls, trench coat, smock, and down jacket is inflected by the femininity of corset, stockings, and garters, or is enriched by Eastern touches, by the influence of caftans and djellabas.

Mixtures and superimpositions make lingerie an item of clothing in itself, so that hybrid costumes like chemise-jackets and pants-skirts make up an unexpected wardrobe. Some accessories, such as ties and leotards, sewn together, become new textile materials. While women have adopted masculine attire, men are not far behind, and in Gaultier's shows they have worn skirts, corsets, and dresses with trains, increasing their masculinity. Gaultier has brought great care to textiles and employed the most luxurious materials; wool, taffeta, and velvet, for example, are blended with rayon, latex, imitation leather, and synthetic tulle. Lycra blended with traditional materials provides comfort in his designs. His designs often give fabrics a worn, faded look, as though they had already been worn. Knitwear in every form, always present, sea-

son after season, has been one of his distinctive signs. Precious fabrics enhance work clothes or military uniforms, and denim flourishes in evening dresses.

Navy blue, khaki, brown, red, and deep purple—Gaultier's original colors—have in the course of time been joined by salmon and powder pink, orange, turquoise, beige, and bronze. His motifs make up a distinctive repertoire: astrology, including the bull's head from his own sign; tattoos, writing, escutcheons, Celtic symbols, and faces; and religious themes like the cross, the star of David, and the hand of Fatima, all appear in a variety of forms on his fabrics, and are printed or sewn on accessories, particularly on jewelry. Stripes, plaids, and polka dots have been fetish designs for Gaultier. Certain details are trademarks, such as fastenings for his clothes: his designs feature distinctive zippers, laces, hooks, tortoiseshell buttons, or buttons with an anchor design.

A creator of images and atmospheres, Jean-Paul Gaultier could not avoid the cinema. He has created costumes for films of Peter Greenaway, Jean-Pierre Jeunet, Pedro Almodóvar, and Luc Besson. He has made stage costumes for Madonna and the dancer and choreographer Régine Chopinot. In 1993 he hosted a television show on Channel 5 in England.

Jean-Paul Gaultier's strong personality and his multifaceted universe have for decades influenced the worlds of both fashion and street clothes. He has enabled people to think about the place of clothing in contemporary society. Breaking the last taboos of the late twentieth century, his designs have exalted the theme of androgyny, brought men and women closer, moved to put an end to the prejudice against age, given sublime expression to the encounter between worlds and cultures, and associated memory with the strictly contemporary.

*See also* **Caftan; Corset; Djellaba; Extreme Fashions; Hermès; Punk; Unisex Clothing.**

#### BIBLIOGRAPHY

- Chenoune, Farid. *Jean-Paul Gaultier*. New York: Universe Publishers, 1998.
- McDowell, Colin. *Jean-Paul Gaultier*. New York: Viking Press, 2001.

*Xavier Chaumette*

**GENDER, DRESS, AND FASHION** Clothing for both men and women is culturally defined. Cultural norms and expectations are related to the meaning of being a man or woman and are closely linked to appearance. In Indonesia, parts of West Africa, and in traditional Scottish dress, men wear an article of clothing that closely resembles a Western definition of a skirt. In Indonesia, both men and women wear the sarong, a length of cloth wrapped to form a tube. The wrapper, a rectangular cloth tied at the waist, is worn by both sexes in parts of West

Africa. The Scottish kilt, still worn at many social gatherings to establish a social and cultural identity, represents the height of masculinity (Kidwell and Steele 1989). In North American culture, the sarong, wrapper, or kilt would rarely be seen on men except within the theater, film, or in the context of couture or avant-garde fashion. For example, the grunge style of the early 1990s had fashions for men designed to be worn with skirts. However, there was nothing particularly feminine about these styles; rather, they were purely a fashion statement.

### Sex, Gender, and Socialization

What is meant by the terms “sex” and “gender”? Although many people use the terms interchangeably, the two words do not have the same meaning. While gender is a social, psychological, and cultural construct, our reason to polarize gender is influenced by sex, that is, the biological dichotomy of male and female. The biological continuum of genes, chromosomes, hormones, and reproductive physiology helps produce a script for appearing and behaving male and female. Viewing gender as a fluid concept allows scholars studying clothing and appearance to understand gender relations as more than men and women “dressing their parts” (Michelman and Kaiser 2000). Gendered dressing is more than complementary role-playing; power relations are inextricably involved. Otherwise, women’s adoption of trousers represents an important readjustment of the definition of femininity, but not necessarily a change in the existing balance of power (Paoletti and Kregloh 1989).

A person’s sex is determined on the basis of primary sex characteristics, the anatomical traits essential to reproduction. One may assume that determining biological sex is a clear-cut process, but a significant number of babies are born intersexed. This is a generic term used by the medical profession to classify people with some mixture of male and female biological characteristics (Newman 2002). For example, a true hermaphrodite is a person born with ovaries and testes. Parents, with the help of professionals in the medical field, make the decision to assign their child to be recognized as either male or female. One of the critical cues that these parents would use is dressing the baby in clothing appropriate to its assigned gender.

Secondary sex characteristics distinguish one sex from another. These are physical traits not essential to reproduction (for example, breast development, quality of voice, distribution of facial and body hair, and skeletal form). Gendered appearance and how we construct our identity are closely tied to these sex characteristics. A body ideal is a size, age, and a combination of physical attributes that society deems to be the most desirable for each gender. For example the early-twenty-first century popular ideal for Western women emphasizes a youthful, slim, athletic, and well-toned physique. Fashion requires women to slavishly conform to this image despite the fact that recent studies have found that the



**Actress Marlene Dietrich in suit.** Women are often less limited than men in their clothing options, as it is generally acceptable for women to wear suits and pants, but not for men to wear dresses. © BETTMANN/CORBIS. REPRODUCED BY PERMISSION.

average American woman is 5 feet 4 inches tall, weighs 142 pounds, and wears a size 14.

Color is a cue that effects how people interact with a child. The response of others to gender-specific colors of attire encourage what is socially designated as gender-appropriate behavior by that child (Stone 1962). Stone observed that dressing a newborn in either blue or pink in America begins a series of interactions. Norms governing gender-appropriate attire are powerful. Gender-specific attire enhances the internalization of expectations for gender-specific behavior. Through the subtle and frequently nonverbal interactions with children regarding both their appearance and behavior, parents either encourage or discourage certain behaviors often related to dress that lead to a child’s development of their gender identity. When a boy decides he wants to play dress-up in skirts or makeup or a daughter chooses to play aggressive sports only with the boys, it would not be surprising to find the parents redirecting the child’s behavior into a more socially “acceptable” and gender-specific activity. Even the most liberal and open-minded parents can be threatened by their child not conforming to appropriate gender behaviors. Research has shown that children as young as two years of age classify people into gender categories based on their appearance (Weinraub et al. 1984).



A person or behavior that deviates from these scripts of gender can be defined as unnatural or pathological (Bem 1993, p. 81). For example, in the movie *Mrs. Doubtfire*, Robin Williams is discovered cross-dressing as a woman. It is at this point in the movie that he is regarded as being suspiciously deviant for such a behavior. What starts as a comedy quickly turns to more serious issues regarding his psychological stability. He is punished for his success at transcending proper gender appearance and behavior.

### Gender as a Social Construction

Gender is a socially constructed phenomenon, and not all cultures aspire to the same physical ideal for men and women as those in Western societies. Likewise, dress can symbolically convey meanings about gender specific to a culture. For example, research on the Kalabari people of Nigeria (Michelman and Erekosima 1992) found that indigenous Kalabari men's attire demonstrates social and political achievement and does not emphasize the procreative aspect of social development, as does women's dress. Men's dress emphasizes social power and responsibility, and women's dress draws attention to moral and physical development. An example of dress emphasizing power is shown by the vertical lines and emphasis on the head in men's dress. Kalabari females progress to full womanhood wearing distinctive styles of dress with ascending values of complexity that mark physical and social maturity. Also of note, is that the ideal adult Kalabari female body is substantial, thick, and plump (Daly 1999) in contrast to an American thin ideal. Researchers have used several critical frameworks to analyze body ideals and dress.

### Cultural Ideals of Body and Dress

One approach to critically analyzing gender and dress is to examine cultural ideals of beauty. In Western culture, a slim waist for women and men is emphasized, along with large breasts and hips for women and broad shoulders and slender hips for men. Greek ideals of beauty are still present in Western culture. The Greek ideal of perfect body proportions has stood the test of time in Western culture (Etoff 1999). Minoan artifacts, which date from 2900 to 1150 B.C.E., illustrate men and women with extremely tiny waists. Some scholars speculate that this was the result of artistic convention while other authorities suggest that young men around the age of twelve or fourteen wore belts that constricted the waist (Tortora and Eubank 1998, p. 48). There have been periods in history when men adopted the corset to achieve the fashionable silhouette of the time (Kidwell and Steele 1989). As a result, neither Western men nor women have escaped Greek beauty ideals.

Given this long-standing Western ideal of body proportions, the continuation of America's obsession with the body comes as no surprise. Common phrases regarding the body include: One can never be too rich or too thin;

no pain, no gain; thin-but-toned; and tall, dark, and handsome. Bodies depicted in magazines are often modified by using computers or airbrushing, allowing models to appear unrealistically beautiful and thin. Body doubles in popular movies mean that viewers might see two or more people standing in for an actor in a leading role. In magazines, the hand putting on the mascara of a beautiful model in an ad might be that of a hand model and not the model herself. The models themselves cannot attain the ideal, as can almost no one else. Some models have admitted to eating-disordered behaviors in the early 2000s. This is largely because clothing, in order to sell, must have "hanger appeal," and fashion models must be walking hangers. Many individuals try to approximate ideals through diet, exercise, and sometimes plastic surgery. Although these ideals are prevalent in American culture, at least one study has indicated that white and African American adolescent girls respond differently to these social pressures (Parker et al. 1995). African American girls get community feedback for developing a style of their own, while the white group gets support for their success in copying the unattainable ideal.

### Codes of Dress and Gender

Through an examination of historical changes in Western men's and women's dress during the twentieth century, it is possible to gain a greater understanding of the changes in the social meanings of clothing and its relationship to gender. Through the 1950s, men followed a restricted code for appearance, limited to angular design lines, neutral and subdued color palettes, bifurcated garments (for example, pants) for the lower body, natural but not tight silhouettes, sturdy fabrics and shoes, and simple hair and face grooming (McCracken 1988). This simple and restricted dress "code" related well to a focus on work and on social, economic, and political accomplishments rather than attention to changes in fashion (Davis 1992). Dress (except for the necktie) did not impede physical activity. The negative impact of this uniformity and conformity is that men may dress to conceal aspects of their identity, which Spindler feels is not always true of women (1994). Men's business attire has been linked to a display of power facilitated by the uniform nature of dress. Joseph (1986) pointed out that uniforms exert a degree of control over those who must carry out the organization's work, encouraging members to express the ideas and interests of the group rather than their own, thus promoting the group's ability to perform its tasks. The opportunity for men to relax at work on "casual Fridays" has not released them from burdens of conformity, as they frequently adopt a Gap or Levi's uniform of polo shirt and khaki pants. This symbolic allegiance to work and career also signals a privileged access to economic and political power in postindustrial society, namely, occupational success. Women's conservative dress-for-success appearance of the 1980s can be analyzed as an appearance cue that announced women's intention to ascend the corporate ladder.

Women, in contrast, have had a more elaborated fashion code, which meant that they could wear some of what men wore, and a lot more. For example, although men always wear pants, women wear both pants and skirts. They have an unlimited choice of fabrics, colors, design lines, and silhouettes. Women also have worn corsets, tight or flowing skirts, high heels, and nylons that have restricted their freedom of movement. Historically, women have been more engrossed than most men in an emphasis on beauty rituals, including fashion, hair, weight control, and makeup, although recent studies indicate that men are catching up with women in their overall concern with their appearance (Garner 1997).

As early as the turn of the twentieth century, both Simmel (1904) and Veblen (1899) noted that with the rise of the urban bourgeois, women without title or other claims to social status were denied access to business, politics, and government. They demonstrated their rising status through clothing, interior decorating, and other consumer activities (Davis 1992). In other cultures, layering of body supplements frequently can indicate an elaborated code related to gender, but it can also serve to demonstrate social rank (Eicher, Evenson, and Lutz 2000). For example, in India, most married women wear bangle bracelets on each wrist. The type of bracelet (plastic, glass, conch shell, silver, ivory, or gold) is appropriate gendered dress as well as an indication of that woman's place in the social hierarchy.

More recently this "code" for men and women was examined in an intra-societal and cross-cultural context (Lynch, Michelman, and Hegland 1998). This research explored the potential of using a system of visual analysis of dress (DeLong 1998) to explore social construction of gender. In three research projects, the investigators found relationships between aesthetic choices and culturally determined gender roles. Lynch found that form and meaning worked together to express either commitment to tradition or openness to change in dress worn by Hmong American women to the New Year's celebration. Michelman concluded that dress worn in the context of traditional women's societies of the Kalabari of Nigeria was linked to cultural ideals of beauty. In contrast, dress worn by women in Nigerian national and international organizations provided a visual challenge to women's constructed gender through the incorporation of visual effects typically found in Kalabari men's dress. Hegland was able to discern degrees of difference in dress among transvestites, transsexuals, and drag queens who are typically placed in one broad category.

### Historic Perspective

Historically, dress and gender have not always been fixed and have enjoyed some latitude. Researching dress and gender from a historical viewpoint stimulates awareness of the shifts regarding appropriate dress for males and females. For example, the expectation of blue is for boy babies and pink for girl babies has not always been the case.

Paoletti and Kregloh (1989) discussed how the color "rule" in 1918 was pink for the boy and blue for the girl. Pink was interpreted then as a stronger and more assertive color and blue as more dainty and delicate.

After World War II, the color preferences for boys and girls reversed. Parents often put elastic pink satin headbands on their hairless girl babies, so that no one is confused about their gender. Babies are also often "color coded" prior to their arrival. Once parents know the sex of their baby, nursery rooms are painted in blue colors for boys and pink for girls. If wallpaper is selected, the themes are often coded by gender, for example, frog, snake, and turtle designs for boys and flower, unicorns, and fairy princess designs for girls. Parents describe their newborns in terms of gender (Cahill 1989). In a study of girl and boy babies of the same weight and length, twenty-four hours after birth, parents were asked to describe the newest addition to their family (Rubin, Provenzano, and Luria 1974). Boys were described as strong, having large hands or feet, and demanding. Girl babies were described as sweet, cuddly, and cute.

In American culture of the twenty-first century, adolescents are often allowed leeway in experimentation with gender and dress, as some adolescent girls may shave their heads and some adolescent boys may have shoulder-length or longer hair. Adults are generally expected to adhere to their societies' rules regarding appropriate gender dress. But gender dress has not always been polarized. For example, during the seventeenth century, adult men's and women's dress shared many of the same elements. A painting of Henri, Duc de Guise by Van Dyck (c. 1634) gives us a glimpse of how aristocratic masculine dress was defined during the first half of the seventeenth century. De Guise's hair is past shoulder length and styled with a "lovelock." He is wearing a profusion of lace at the collar and cuff areas of his doublet and below the knee of his breeches, his doublet opening is held together with a bow, and he carries a wide-brimmed hat decorated with a large plume. His knee-high boots are also elaborately decorated. De Guise's portrait appears especially feminine when compared with contemporary American male dress.

Queen Henrietta Maria in a portrait by Van Dyck (*Queen Henrietta Maria with Sir Jeffrey Hudson*, 1633) has similar details to her costume as de Guise's in that she is wearing her hair in a "lovelock" style, a large brimmed, plumed hat, and her collar and three-quarter-length sleeves are decorated with a profusion of lace. However, Queen Maria's portrait in some respects is more streamlined and less fussy than de Guise's in that the line of her skirt is not broken up and her legs and feet are hidden while de Guise's lacy knee breeches and decorated boots break up the line of his lower body.

According to Davis (1992), the dress of the European aristocracy changed in the 1800s when men's dress became a means of communicating economic success and

women's dress continued to follow an elaborate dress code. As a result, men assumed a highly restricted dress code as the European aristocracy began to decline and the advent of industrial capitalism began. Therefore, we see fewer similarities between men's and women's dress in modern culture at the start of the twenty-first century compared with the seventeenth-century dress of European aristocrats.

### Gender, Dress, and the Self

Eicher (1981) proposed a model for viewing dress and the different aspects of the self. She stated that the public self is the part of the self we let everyone see, the private self is the part of the self we let only family and friends see, and the secret self we let no one or only intimates see. One hypothesized disparity between men and women in American culture is that dress for the secret self (what Eicher calls fantasy dress) is more restricted for men than women. In other words, women are allowed to purchase fantasy dress for the secret self more so than men. In order to test Eicher's hypothesis, Miller (1997, 1998) surveyed historic reenactors regarding their use of costume during living history events and reenactments.

In 1997, Miller found that women reenactors have more sexual fantasies about dress than men, supporting Eicher's (1981) hypothesis that American women feel more freedom to dress out fantasies than men. Female reenactors also reported more childhood memories about dress than men, indicating that boys and girls are socialized differently about dress (Vener and Hoffer 1965).

In 1998, Miller reported that among costumed reenactors surveyed, females dress in costume primarily to assume another persona, whereas males dress in costume primarily because of their love of history. In written responses to open-ended questions, male reenactors distanced themselves from such descriptions of their hobby as "fantasy," "costume," and "dress-up." Women on the other hand embraced these terms and indicated that people don't dress in costume only on the weekends (for reenactments), but for every day. As a result of these two studies by Miller (1997, 1998) and in collaboration with Eicher, a new grid model was developed for dressing the public, private, and secret self (Eicher and Miller 1994).

### Gender Markers

Some aspects of dress mark the gender of an individual more than others, for example, a corset, footbinding, interest in fashion, a codpiece, and maternity apparel. Corsets have been associated with female morality, with the tight-laced woman as moral and the unlaced woman as "loose" and immoral. In addition, corsets have been blamed for displacement of internal organs and disfigurement of the female body during the 1800s; however, these accounts are generally considered few in occurrence and possibly overstated (Steele 1999). One cannot deny the erotic appeal of corsets, and Steele (1999) has used representations of the corset in art, illustrations, and ad-

vertising to discover that the corset shares a close association with female erotic beauty.

Corsets have also been worn by men, although less frequently than by women. For example, during the nineteenth century, the ideal for a fashionably dressed male included a rounded silhouette. These illustrations show the areas of the body that were to be rounded by padding (shoulder, chest, hip, and calf). Tight corseting created a small waist and emphasized the padded areas of the body by contrast.

Footbinding, once performed in China, was a disfiguring and socially acceptable practice performed exclusively on females and was closely linked with eroticism (Jackson 1997). Women in China followed a centuries-old tradition of breaking and binding their feet to achieve a lotus bud shape. This shape was purportedly sexually attractive to males and created high social status while increasing the likelihood of marriage among Chinese women.

Women are often accused of being excessively interested in fashion. But throughout history one can find examples of men who were also extremely interested in fashion. During the late 1700s, the king of France, Louis XVI, was very interested in fashion; he wore hose and high heels to call attention to his calves, and he wore a high wig to increase his height. Attention to fashion among men reached its zenith between 1796 and 1816 when Beau Brummell became the undisputed arbiter of men's fashions in England: "Brummell was famous for his impeccable dress. . . . [H]e personified the Regency 'dandy,' a fashionable man who dressed well, circulated in the 'best' society, and who was always ready with a witty comment" (Tortora and Eubank 1998, p. 265).

The codpiece is one gender marker exclusively for men. In the sixteenth century, a small pouch of fabric was needed to join separate legs of hose to create trousers. This small piece of fabric was used to place emphasis on the male genitalia. From 1500 to 1560 the codpiece would grow in size, be padded, slashed, decorated, and used by men to carry coins, keys, and tobacco.

Maternity apparel, like the codpiece, is gender specific, and illustrations of pregnant women over time show that the public perception of pregnancy has greatly influenced the style of maternity apparel available. For instance, maternity career apparel became available during the last half of the twentieth century largely because popular opinion found it acceptable for women to work while pregnant (Belleau, Miller, Elliott, and Church 1990). This approach is in contrast to the Victorian era when pregnant women were said to be "in a family way" and were expected to remain at home and out of public view. Juxtapose the Victorian image of a pregnant woman with a more recent image of Demi Moore, nude and pregnant, on the cover of *Vanity Fair* in the early 1990s and you begin to see how society's perception of pregnancy has changed over time (Damhorst, Miller, and Michelman 1999).



### Social Resistance

Dress can be a powerful, nonverbal indicator of political beliefs. Examples demonstrating this relationship include uniforms, religious garb, and fashion. Political dress can convey a clear and positive message regarding the wearer's beliefs and affiliation. Sometimes this dress can also be closely associated with the "politics of gender." Feminism has challenged what is taken for granted about gender with a political goal of changing the world and transforming gender relations so that women and men alike can fulfill their human potential (Ramazanoglu 1989, p. 8). Feminists examine gender as a fluid concept that shifts in its meaning and expression according to time, place, social class, race/ethnicity, sexuality, age, and other variables. Issues of gender and power are part of the feminist analysis of dress and fashion. The fashion and image industries build their sales by playing with the boundaries of gender and power. For example, the semi-masculinized fashions designed for women by Ralph Lauren, Giorgio Armani, and Calvin Klein can be interpreted as sexy, assertive, urbane, and most decidedly upper class but never something that would be worn by a man.

**Athletic dress.** Dress can be an important way to express political resistance and frequently is associated with the power relations of gender. Examples can be found in many cultures around the world. The history of women's athletic dress from gym suit to the current athletic fashions provides a study in the power of the gendered resistance of dress. The early gym uniform was more than just attire for physical education; rather, it symbolized the long, slow process of adoption of the trouser form for women. Warner believes that the clothing for women's athletics has had a wider influence on women's clothing in the twentieth century than any other, except dance (1993, p. 191). In 1972, Title IX legislation demanded equal funding of athletic programs for females and males in schools across the United States. Since then, increasing numbers of girls and women participate in sports that have traditionally been seen as out of bounds for them, including lacrosse, wrestling, soccer, rugby, and ice hockey. As women's opportunities in athletics have multiplied, so has their chance to expand the "boundaries" of their dress. Serena Williams, the American tennis star, exemplifies resistance to the boundaries of gender and femininity. She is comfortable in designer dresses that display her muscular arms and legs as well as tennis clothing and a physical appearance that was once reserved for only the most accomplished male athletes. She is highly feminine and simultaneously supremely athletic, an appearance resistant to a frail, feminine ideal of beauty.

**Religion and resistance.** Recent events in other cultures provide examples of dress as resistance. From a Western perspective, Muslim women's veiling appears a form of great social repression. Indeed, in some cases, this may be true, such as the 1990s rules of public appearance for women under the Taliban rule of Afghanistan. The *burqa*,

a total body covering, clearly represents a type of oppression to many Afghani women, although its long-standing place in Afghan culture is complicated. What may have been more distressing were the Taliban rules that prevented women from working or attending school. In the Muslim countries of Algeria, Egypt, and Iran, the return to veiling practices indicates a return to more traditional values of modesty, religious values, family virtue, and an aversion to Western consumerism—that is, fashion. For many women, veiling is resistant to certain prevailing social norms and an assertion of their personal and social identity (El Guindi 2000).

Conservative Holdeman Mennonite women also use dress to combat patriarchal control. Young women are allowed some leeway when it comes to the strict dress code of the Mennonites, and the older women who police the behavior of the younger women often overlook deviations in young women's dress. Arthur (1993) found that young Mennonite women used lightly applied makeup, worldly clothing hidden in school lockers, and dyed high-heel shoes in black or brown to bend rules established by the male ministers. Even though Mennonite communities maintain strict dress codes, most men defer to their wives when raising daughters. Women help keep each other in line while overlooking some deviations. Both behaviors were considered "a double nature to the agency of Mennonite women" (p. 83).

### Conclusion

Clearly, gender as a social and cultural construction needs—demands—the appropriate props to successfully convince the audience that one's gender presentation is authentic. The dress we wear is layered with many meanings, such as culturally appropriate gender behavior, gender socialization via dress, codes of dress and gender, historical perspectives of dress and gender, dressing parts of the self, social resistance, and gender markers.

*See also:* **Codpiece; Cross-Dressing; Fashion and Homosexuality; Maternity Dress; Reenactors; Religion and Dress; Unisex Clothing**

### BIBLIOGRAPHY

- Arthur, L. B. "Clothing, Control, and Women's Agency: The Mitigation of Patriarchal Power." In *Negotiating at the Margins*. Edited by S. Fisher and K. Davis, 66–84. New Brunswick, N.J.: Rutgers University Press, 1993.
- Barnes, Ruth, and Joanne B. Eicher, eds. *Dress and Gender: Making and Meaning*. London: Berg, 1992.
- Belleau, B. D., K. A. Miller, P. Elliott, and G. E. Church. "Apparel Preferences of Pregnant Employed Women." *Journal of Consumer Studies and Home Economics* 14 (3): 291–301.
- Bem, S. *The Lenses of Gender: Transforming the Debate on Gender Inequality*. New Haven, Conn.: Yale University Press, 1993.
- Cahill, S. E. "Fashioning Males and Females: Appearance Management and the Social Reproduction of Sex." *Symbolic Interaction* 12 (1989): 281–298.

- Daly, M. Catherine. "Ah, a Real Kalabari Woman!": Reflexivity and the Conceptualization of Appearance." *Fashion Theory* 3(3) (1999): 343–361.
- Damhorst, M. L., K. A. Miller, and S. O. Michelman, eds. *The Meanings of Dress*. New York: Fairchild Publications, 1999.
- Davis, F. *Fashion, Culture, and Identity*. Chicago: University of Chicago Press, 1992.
- DeLong, M. R. *The Way We Look: Dress and Aesthetics*. 2d ed. New York: Fairchild Publications, 1998.
- Eicher, J. B. "Influences of Changing Resources on Clothing, Textiles, and the Quality of Life: Dressing for Reality, Fun, and Fantasy." *Combined Proceedings: Eastern, Central, and Western Regional Meetings of Association of College Professors of Textiles and Clothing* (1981): 36–41.
- Eicher, J. B., S. L. Evenson, and H. A. Lutz. *The Visible Self: Global Perspectives on Dress, Culture, and Society*. 2nd ed. New York: Fairchild Publications, 2000.
- Eicher, J. B., and K. A. Miller. "Dress and the Public, Private, and Secret Self: Revisiting a Model." *ITAA Proceedings*. Proceedings of the International Textile and Apparel Association, Inc. (1994): 145.
- El Guindi, F. *Veil: Modesty, Privacy and Resistance*. Oxford: Berg, 2000.
- Etcoff, N. *Survival of the Prettiest*. New York: Doubleday, 1999.
- Garner, D. M. "The 1997 Body Image Survey Results." *Psychology Today* 30 (1) (January/February 1997): 30–44, 75–76, 78, 80, 84.
- Jackson, B. *Splendid Slippers*. Berkeley, Calif.: Ten Speed Press, 1997.
- Joseph, N. *Uniforms and Nonuniforms: Communicating through Clothing*. New York: Greenwood Press, 1986.
- Kidwell, C., and V. Steele. *Men and Women: Dressing the Part*. Washington, D.C.: Smithsonian Institution Press, 1989.
- Lynch, A., S. Michelman, and J. Hegland. "Cross-cultural and Intra-societal Application of DeLong's Framework of Visual Analysis." *Clothing and Textiles Research Journal* 16(4)(1998): 145–156.
- McCracken, G. *Culture and Consumption*. Bloomington: Indiana University Press, 1988.
- Michelman, S., and T. Erekosima. "Kalabari Dress: Visual Analysis and Gender Implications." In *Dress and Gender: Making and Meaning*. Edited by R. Barnes and J. Eicher, 164–182. Oxford: Berg, 1992.
- Michelman, S., and S. B. Kaiser. "Feminist Issues in Textiles and Clothing Research: Working through/with the Contradictions." *Clothing and Textiles Research Journal* 18(3) (2000): 121–127.
- Miller, K. A. "Gender Comparisons within Reenactment Costume: Theoretical Interpretations." *Family and Consumer Sciences Research Journal* 27 (1) (1998): 35–61.
- Miller, K. A. "Dress: Private and Secret Self-Expression." *Clothing and Textiles Research Journal* 15 (4) (1997): 223–234.
- Newman, D. *Sociology: Exploring the Architecture of Everyday Life*. Thousand Oaks, Calif.: Pine Forge Press, 2002.
- Paoletti, J., and C. Kregloh. "The Children's Department." In *Men and Women: Dressing the Part*. Edited by C. Kidwell and V. Steele, 22–41. Washington, D.C.: Smithsonian Institution Press, 1989.
- Parker, S., M. Nichter, et al. "Body Image and Weight Concerns among African American and White Adolescent Females: Differences That Make a Difference." *Human Organization* 54 (2) (1995): 103–114.
- Ramazanoglu, C. *Feminism and the Contradictions of Oppression*. London and New York: Routledge, 1989.
- Roach-Higgins, M. E., and J. B. Eicher. "Dress and Identity." *Clothing and Textiles Research Journal* 10 (1992): 1–8.
- Rubin, J., F. Provenzano, and Z. Luria. "The Eye of the Beholder: Parent's Views on the Sex of Newborns." *American Journal of Orthopsychiatry* 44 (1974): 512–519.
- Simmel, G. "Fashion." *American Journal of Sociology* 62 (1957): 541–558 (originally published in 1904).
- Spindler, A. "Men in Uniformity." *New York Times Magazine*. *Men's Fashions of the Times* (1994, September 25): 16, 18.
- Steele, V. "The Corset: Fashion and Eroticism." *Fashion Theory* 3(4) (1999): 449–474.
- Stone, G. "Appearance and the Self." In *Human Behavior and Social Processes: An Interactionist Approach*. Edited by A. Rose, 86–118. New York: Houghton Mifflin, 1962.
- Tortora, P., and K. Eubank. *Survey of Historic Costume*. 3rd ed. New York: Fairchild Publications, 1998.
- Veblen, T. *The Theory of the Leisure Class*. New York: Mentor Books, 1953 (originally published in 1899).
- Vener, A. M., and C. R. Hoffer. "Adolescent Orientations to Clothing." In *Dress, Adornment and the Social Order*. Edited by M. E. Roach and J. B. Eicher, 76–81. New York: John Wiley and Sons, 1965.
- Warner, P. "The Gym Suit." In *Dress in American Culture*. Edited by P. Cunningham and S. V. Lab, 140–179. Bowling Green, Ohio: Bowling Green State University Popular Press, 1993.
- Weinraub, M., et al. "The Development of Sex Role Stereotypes in the Third Year: Relationships to Gender Labeling, Gender Identity, Sex-Typed Toy Preference, and Family Characteristics." *Child Development* 55 (1984): 1493–1503.

Susan O. Michelman  
Kimberly A. Miller-Spillman

**GERNREICH, RUDI** Rudi Gernreich was born on 8 August 1922 in Vienna and died in 1985. Gernreich's family came from the nonreligious Jewish middle class and had ties to the Social Democrats. One of his mother's sisters ran a fashion salon in Vienna where the newest French designs were translated with high-quality craftsmanship.

In 1933 Austria, having affiliated itself with Nazi Germany, became the scene of rampant anti-Semitic violence. Rudi Gernreich and his mother were able to flee to Los Angeles. Gernreich studied art for a few semesters and quickly made a connection in Los Angeles with The Modern Dance Studio of Lester Horton, whose choreography was concerned with antifascist themes and racial discrimination. In the mid-1940s, his first sketches for dance costumes appeared. For a few years, Gernreich

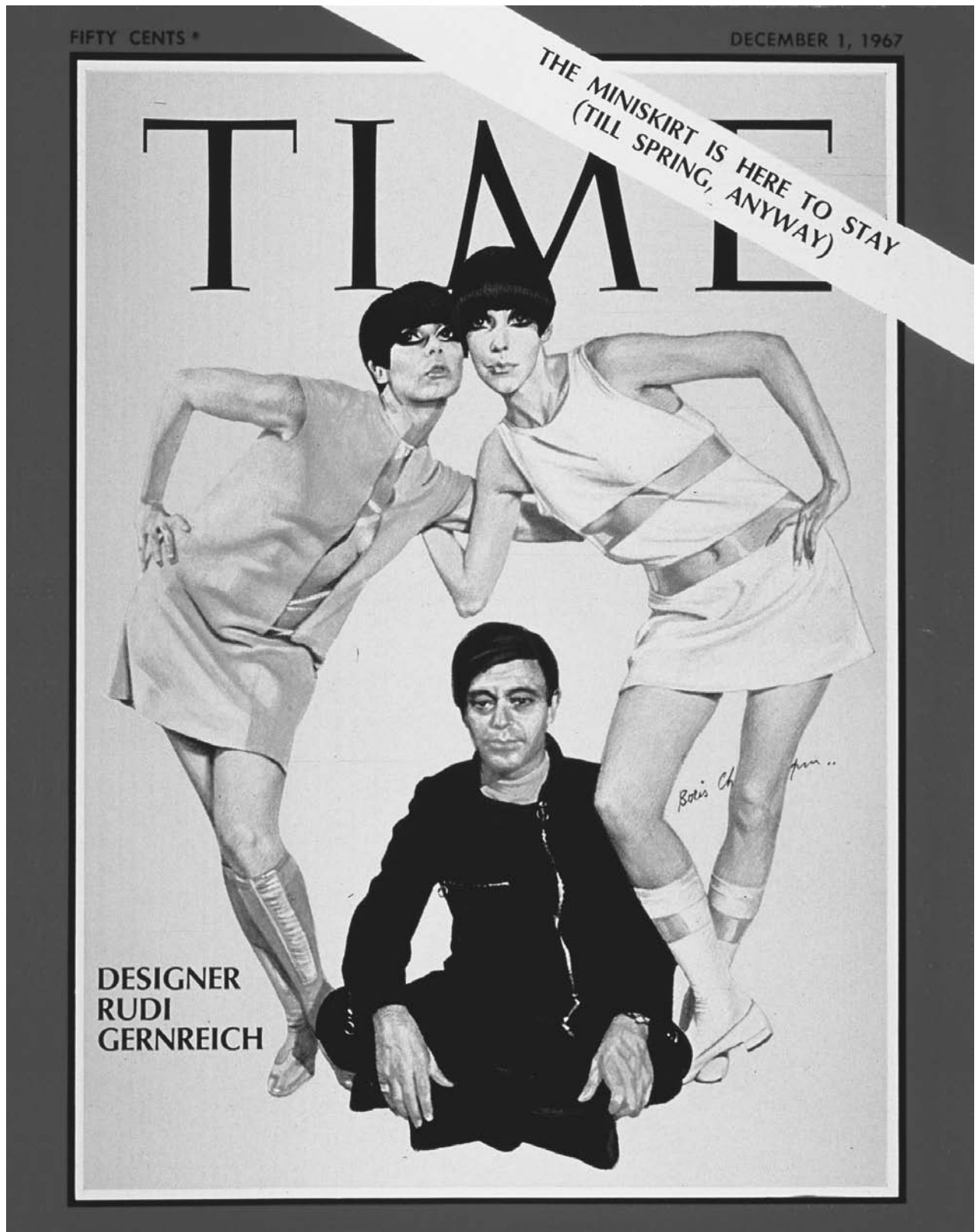

Rudy Gernreich on the cover of *Time* magazine, December 1, 1967. Born in Vienna, Austria, Gernreich was well known for using provocative fashion designs, such as the “monokini,” to express the 1950s and 1960s generations’ desire for freedom. TIME LIFE PICTURES/GETTY IMAGES. REPRODUCED BY PERMISSION.



was a fashion designer for Adrian and others before developing his first small collection in 1948. In the late 1940s he worked for a short time in the garment district of New York's Seventh Avenue, returning eventually to California. Around 1950 he developed a collection of sportswear for Morris Nagel, which featured interchangeable pieces. Hattie Carnegie engaged Gernreich for a few months during which he provided her with design sketches. In 1950 he met Harry Hay (1912–2002), who was a member of the California Communist Party and an activist union organizer. Hay and Gernreich founded the secret Mattachine Society, one of the first organizations to agitate for homosexual rights.

In 1952 Gernreich began work for Walter Bass, and his first designs were an immediate success. The newly founded Beverly Hills boutique, JAX, as well as department stores like Lord and Taylor in New York and Joseph Magnin in San Francisco, sold Gernreich's sportswear. Gernreich developed jersey tube dresses and printed nylon stockings and used synthetic materials. Starting in 1955 Gernreich also designed knitted bathing suits. In 1954 he met Oreste Pucciani, the future chairman of the UCLA French department, and began a relationship that would last until Gernreich's death in 1985. Finally in 1960, Gernreich established his own company: Rudi Gernreich Incorporated. In 1964, the monokini, or topless bathing suit, brought the name Gernreich into the headlines. In 1968 Gernreich closed his company but continued his work as a designer.

From the beginning of his career, Gernreich also designed costumes for various film productions, such as Eva Marie Saint's wardrobe in Otto Preminger's 1960 film *Exodus*. In 1970 he designed "Dress Codes" of the new decade for the January issue of *Life* magazine. Gernreich's fashion concept of the future was "unisex." In 1971 he presented an ironic military collection: jersey pieces in uniform colors, mounted pockets, and models armed with guns. In 1972 Gernreich developed a perfume, which came in a bottle shaped like a chemical laboratory beaker. Gernreich never thought of his activity as a designer as limited to fashion alone; clothing was only one possible expression of a freely chosen lifestyle.

Gernreich's 1950s bathing suits were influenced by the work of the American designer Claire McCardell. Gernreich's suits, conceived as an expression of a new body consciousness, were unstructured and emphasized the body's natural form. In 1965, Gernreich accessorized his bathing suits with visors, over-the-knee vinyl boots, and even fishnet stockings. In 1961 Gernreich's bathing suits and clothes featured cutouts, and in 1968 he used transparent vinyl inserts, which integrated the skin and silhouette of the wearer into the clothing.

The monokini, or topless bathing suit, first presented in 1964, finally made Gernreich internationally famous. Gernreich's monokini consisted of a rib-cage-height bottom, held up with shoulder straps. Gernreich had wanted

to liberate the bosom from its status as something that had to be kept concealed. He also used this idea in his underwear collection "No." The bras from the collection, the "no bra," the "maybe bra," or, later, the "almost bra," were distinguished by their transparency and lightness. The thong, presented in 1974, is part of the standard repertoire of clothing in the early 2000s.

Gernreich used patterns—bold animal skins or graphic decorations—in clothing, accessories, and even underwear. The body became, in the Total Look, an abstract, aesthetic element, and clothing became a conscious field of aesthetic experimentation, like architecture or furniture design. The fall collection of 1964 featured a suit of a top and skirt and matching stockings, with dark-blue and gray (oyster) vertical stripes, completed by garish green patent-leather pumps. In 1966, three models, Peggy Moffitt, Léon Bing, and Ellen Harth, appeared in William Claxton's short film *Basic Black*, which focused on Rudi Gernreich's fashions. All three mannequins wore suede suits, with dalmatian, giraffe, and tiger-skin patterns complete with matching patterned accessories: caps, gloves, pumps, stockings, and even underwear.

Gernreich's collections often featured uncommon color combinations, such as black and white, orange and yellow, or red and purple, and the juxtaposition of differing graphic motifs, such as stripes with polka dots, checks with diagonal stripes, zigzags with cubes. On the one hand, the influence of the Vienna Workshops is apparent, on the other hand, Gernreich was responding to the antifashion of the 1960s and 1970s, whose signals and messages he transformed. "Real T-shirts are worn with slogans or Mickey Mouse figures or letters. All of these deliver messages. I have abstracted these signals into symbols, conveying them by various inserts: panels, stripes, or circles" (*Topeka State Journal*, 23 February 1972). Instead of extravagant tucks, folds, or piping, Gernreich accentuated and molded particular body parts through the optical effect of colors and patterns. With refined trompe l'oeil effects, the illusion of a multiple-piece suit was created.

Gernreich's collections often included elements of folklore, quoted and freshly adapted: the pattern mixture of Austrian dirndl, the hussar's uniform with embroidery on black vinyl, or elements of Chinese and Japanese clothing, such as obis or colorfully patterned silks. The 1968 collection was criticized by the press at the time as not contemporary enough and seemed to many to even contradict Gernreich's modernism. But the designer had not intended to offer romantic dress-up as an escape from reality, but rather as a medium for a continual self-exploration or role-play. According to Gernreich, such a repertoire of historical and national style elements could only be successfully introduced in a free society whose members were capable of personal exploration and experimentation with a confident mastery of existing dress codes.

Gernreich always advocated the interchangeability of men's and women's clothes. In the Unisex Project of 1970, for example, Gernreich arranged for a woman and a man to be shaved completely of body hair. Then the pair modeled identical clothing: both in bikinis or miniskirts, both topless. In the conception of his unisex-style, Gernreich chose abstract, unromantic, democratic clothing which was intended to be available to all—in Gernreich's words: "an anonymous sort of uniform of an indefinite revolutionary cast" (*Michigan News*, 15 July 1971).

"We have to take this terrible world and make fun of it with fun clothes, functional clothes" (*Los Angeles Herald Examiner*, 29 September 1966). Already in 1954 Gernreich had used white vinyl for an evening dress. He tried to break through the traditional boundaries of clothing manufacture by using new materials. He was not only interested in the aesthetic characteristics of synthetic materials, but also in their manufacturing possibilities. He hoped to produce seamless clothing, but was frustrated due to the inability, at the time, to overcome technical problems. In addition to synthetic materials, Gernreich favored mechanical elements like zippers or metal fasteners, and he incorporated elements of both motorcycle clothes and dance leotards in his designs. He designed overalls with detachable pants legs, sleeves, or skirts, which could be altered at will.

"I consider designing today more a matter of editing than designing," said Gernreich describing his aesthetic method (*Los Angeles Times*, 30 January 1972). During the course of his career Gernreich utilized various styles, drawing upon austere secessionist patterns for casual slacks, reworking the simple cut of a sleeveless dress, season after season, with new materials and color combinations, introducing industrial materials like vinyl, or historical costumes for greater social flexibility. The exclusivity of expensive craftsmanship, the value of a particular material, or the refined solution to a particular technical sewing problem—be it sleeve holes or folds—would not have harmonized with Gernreich's design intentions. He reduced clothing to an inventory of functional pieces, which could be infinitely varied with colors, materials, or patterns.

Fashion magazines ignored, for the most part, his taboo-breaking, subversive fashion strategies. Gernreich, however, always saw his fashion concepts as carriers of a total, aesthetically formulated worldview. With the monokini he succeeded in pushing the fashion envelope. He utilized the success and fame awarded by his first collections in the 1950s to introduce his new aesthetic concepts about contemporary and futuristic clothing theory to the public eye. Art and fashion, thus, were never separated worlds for him. In the 1950s and 1960s, Gernreich was accepted in artistic circles because he had utilized fashion to radically question societal conventions. He rejected the idea of fashion as a corset of socially relegated hierarchy and rigid gender polarization. He used ironically provocative concepts such as the monokini, topless, uni-

sex, and the Total Look to articulate a generation's desire for freedom as program.

See also **Ethnic Style in Fashion; McCardell, Clare; Unisex Clothing.**

#### BIBLIOGRAPHY

- Faure, Jacques, ed. *Rudi Gernreich. A Retrospective*. Los Angeles: Fashion Group Foundation, Inc., 1985.
- Felderer, Brigitte, ed. *Rudi Gernreich: Fashion Will Go Out of Fashion*. Catalog for eponymous exhibition from Oct. 7 to Nov. 26, 2000. Künstlerhaus Graz, Cologne: Dumont, 2000.
- Lobenthal, Joel. *Radical Rags: Fashions of the Sixties*. New York: Abbeville Publishers, 1990.
- Moffitt, Peggy. *The Rudi Gernreich Book*. New York: Rizzoli, 1991. Photography by William Claxton. Essay by Marylou Luther.

Brigitte Felderer

**GIGLI, ROMEO** The designer Romeo Gigli was born in 1949 in Castelbolognese, near Faenza, Italy, into a family of antiquarian booksellers with a collection of more than twenty thousand volumes from the fifteenth and sixteenth centuries. The region of Faenza has a rich cultural and historical heritage. It was there, in the Byzantine mosaics of Ravenna and in the rare books in his family's library, that Gigli found the initial inspiration for his future art.

Gigli studied architecture in Florence. At the end of the 1970s, after ten years spent traveling around the world, during which time he collected objects, fabrics, and clothing, he began to take an interest in fashion. In 1979 he went to New York, where Pietro Dimitri, a tailor who made custom clothing for men, asked Gigli to design a line of women's clothing. It was a defining moment for Gigli, who, after returning to Italy and settling in Milan, decided to enter fashion on a full-time basis. In 1983 he launched the Romeo Gigli label, which was produced by Zamasport beginning in 1985.

Gigli broke with existing conventions, revolutionizing the approach to women's fashion common in the 1980s. During a period characterized by padded shoulders and aggressive sexuality, Gigli introduced a new look for women—one that was romantic and intimate. He turned away from the hard-edged contours that were then prevalent and based his designs on classic proportions, which he updated, sometimes radically. He made use of contrast and asymmetry and combined simplicity with luxurious fabrics, sometimes pairing smaller, microlength designs with long, full garments. He made use of unusual combinations of colors, such as sand and pink, dark blues, verdigris, saffron, red, and gold, and of fabrics, such as stretch linen, silk, chiffon, cotton gauze, wool, and cashmere. And he was one of the first designers to use Lycra.

The Gigli woman is ethereal and silent, fragile and poetic; her conical silhouette, with its long, narrow sleeves and layered overcoats, jackets, and scarves, emphasizes the sensuality of a woman's arms and shoulders, her gestures and bearing. Even Gigli's men's collection, begun in 1986, broke with the traditional schema and returned to classical proportions and uncommon pairings of materials. He reintroduced the three-button jacket and the natural, or Neapolitan, shoulder; his pants were narrow and his shirts colorful. The Gigli man is neither aggressive nor a dandy; he is an intellectual, casual in appearance only, careful in his choice of colors and fabrics.

In 1987 Gigli signed an agreement with Takashimara—the Japanese department store specializing in luxury and quality goods—for the exclusive production and distribution of the women's ready-to-wear collection and men's and women's accessories.

For several years Gigli showed his clothes in Paris, where he was received with considerable enthusiasm. In Milan his showrooms at 10 corso Como, Spazio Romeo Gigli, which opened in 1988 in a former automobile repair shop in the working-class Garibaldi neighborhood, have become a place of cult worship for intellectuals and fashion rebels, for whom Gigli is the undisputed leader.

One of his women's perfumes, Romeo di Romeo Gigli, received the International prize Accademia del Profumo for the best packaging of 1989 and the award of the American Fragrance Foundation for the best packaging of 1991.

In 1990, he launched the G Gigli line, produced by Stefanel for a younger market. From 1987 to 1996 he designed Callaghan for Zamasport, a collection of richly decorated ethnic clothing. In 1993 he started a cooperation with Christopher Farr's Handmade rugs for the carrying out of carpets in a limited edition.

Because of disagreements with his associates, Gigli decided to completely redefine his activity. He continued as the artistic director of Gigli Spa, a part of IT Holding, which was founded in 1999 and which produces and distributes products associated with the Gigli name. Romeo Gigli, considered Italy's poet-designer, has been a forerunner of minimalism and understatement in modern clothing design. His stylistic and conceptual innovations have been widely imitated.

See also **Elastomers; Ethnic Style in Fashion; Italian Fashion.**

#### BIBLIOGRAPHY

- Borioli, G. "Gigli." In *Dizionario della moda*. Edited by Guido Vergani. Milan: Baldini and Castoldi, 1999.
- Giordani Aragno, Bonizza. *Callaghan: 1966. La nascita del prêt-à-porter italiano*. Milan: Mazzotta, 1997.

*Simona Segre Reinach*

**GIRDLE** Mary Brooks Picken defined girdle as a "flexible, light-weight shaped corset, made partly or entirely

of elastic. Worn to confine the figure, especially through the hip line." Merriam-Webster's *Collegiate Dictionary* offered: "A woman's close-fitting undergarment often boned and usu. [*sic*] elasticized that extends from the waist to below the hips." Neither definition does full justice to the undergarment that changed shape, materials, and functions through its six decades of prominence in women's wardrobes, from the 1910s through the 1960s. Girdles evolved continuously to take advantage of new fibers and fabric structures and to respond to each new silhouette in women's outerwear. Pantie girdles came on the scene when substantial numbers of women began to wear pants. Initially, girdles appealed to younger women and teen girls, but women of all ages eventually wore some type of girdle, before control-top panty hose supplanted the girdle's functions for all but the most conservative women.

The modern girdle's origin may be traced to the short hip-confiners worn over corsets during the early 1900s, but the term itself began to assume its contemporary meaning in the mid-1910s. Treo, an early manufacturer, applied the term girdle to its flexible Para rubber corsets without laces. Competing terms to describe girdles included the French ceinture, belt, and sash. In 1916, Stanford Mail Order Company, New York, marketed girdles to "Misses and Small Women." At the outset, girdles were associated with youth and informality, in part because their light control suited the figures and activities of a younger clientele. However, rubber "reducing girdles" were sold to weight-conscious women of all ages.

#### Flappers and Girdles

In the famously unconstrained 1920s, teens and young women, collectively termed flappers, generally abhorred the heavy corsets on which their mothers depended for figure control. Fashionable young women often rolled their stockings and limited underwear to a wispy bandeau and step-in panties. By the mid-1920s, as a contoured silhouette began gradually to return to women's fashions, flappers and other fashionables accepted garter belts and light girdles. The advertising agency J. Walter Thompson reported the views of a Manhattan department store buyer thus: "widely talked of abandon [*sic*] of corsets was a myth. Even flappers wear something, if it's only a garter belt or corselette." Girdles of the 1920s usually extended from natural waistline to hipline, came in white or peach-tone knit elastic, and were worn over step-ins. More conservative girdles included woven brocade panels over the tummy and derriere. Generally priced from \$1 to \$6 dollars, girdles appealed to the budgets of young women.

#### Thriving During the Depression

In the 1930s, technology and fashion converged to produce styles of girdles that sold by the millions, despite the persistence of the business depression. Unit sales of girdles topped 20.6 million in 1935 alone ("The Corset," *Fortune*, March 1938). Technological innovation arrived



in the form of Lastex, an extruded (spun) rubber latex yarn covered by mercerized cotton. Put on the market in autumn 1931, Lastex made possible the lightweight two-way stretch girdles that gained wide appeal, especially with young customers, for their ability to move with the body. Lastex hand-washed easily and provided control without boning, though some girdles added a few bones and often had panels of woven fabric to tame front and rear bulges.

Warner made knitted Lastex girdles, whereas Kops Brothers specialized in woven two-way stretch fabrics. By the end of the 1930s, makers had devised tubular, seamless knitted girdles and knits of differential density and tension for molding different parts of the wearer's anatomy.

Fashion also contributed to the survival of girdles. Throughout the 1930s, dress silhouettes gradually became fuller in the bust, slimmer and higher in the waist, and gently curved and elongated in the hips. Compared with the changes in bust contours and bras, where aggressive uplift held sway by 1939, girdle shapes altered only subtly. Fashion's overall trimness of line meant that all but the very young and slender needed a girdle (or corselette) to wear a chic dress well.

Fashionable women's 1930s wardrobes began to include pants, primarily for active sports, gardening, and strictly informal social events. Enter the pantie girdle. Beginning about 1934, pantie girdles constituted a staple in the lines of many manufacturers. Most panties had garters, because stockings continued to be worn under pants, but a few styles featured removable garters or special leg bands to hold down the girdle when socks were worn or the woman went barelegged. Regular girdles were marketed for all purposes, from housework to evening parties, and at prices that ranged from 59 cents to \$15 dollars.

Like bras, girdles sold mainly in peach (like present-day nude) or white, but by 1939 at least a couple of makers offered black girdles. "Talon slide fasteners"—zippers—appeared in slightly heavier or fancier girdles. Talon argued that roll-on girdles caused frustrating tugging matches. A girdle could be as short as eight inches—like a glorified garter belt—but most came in ten-, twelve-, fourteen- and sixteen-inch lengths, varying with both the height of the wearer and her need for control at the hip and waist.

Girdle manufacturing was widely dispersed during the 1930s, with many of the 240 corset companies ("The Corset," *Fortune*, March 1938) producing some type of girdle. Some stores featured private-brand girdles, but generally the industry divided between prestige-brand makers and small, marginal firms. Even the better-known companies split between those grounded in corset-making, such as Maidenform and Formfit, and those derived from knit underwear makers, including Carter, Kayser, and Munsingwear.



**A 1920s girdle.** Girdles of the 1920s usually extended from waistline to hipline, came in white or peach-tone elastic, and were worn over step-in panties. Priced from \$1.00 to \$6.00, they appealed to young women shoppers. © HULTON-DEUTSCH COLLECTION/CORBIS. REPRODUCED BY PERMISSION.

### Wartime Retrenchment and Postwar Expansion

New fibers and innovative marketing might have constituted the core of the girdle story in the 1940s but for the hiatus of World War II. Nylon, introduced for hosiery in 1939, was offered in girdles in 1940; Formfit and other companies marketed all-nylon and blended-fiber girdles by that autumn. Nylon and Lastex created strong, light powernet, so effective in girdles for the junior market. Latex film Playtex all-way-stretch girdles offered another route to smooth control.

As war approached, the U.S. government took possession of strategic textiles, including nylon and latex. Regulation L90 stipulated allowable amounts of elastic in girdles and other undergarments; however, neither Lastex nor nylon wholly disappeared from girdles or bras. Small sections of elastic provided some relief from rigidity. Knitted fabrications helped too, but wartime girdles often looked and felt dowdy to young customers. Pantie girdle sales held up well, because women working in armaments factories often wore pants or coveralls, which looked better over a pantie girdle. Slim and fit girls just wore garter belts or inexpensive briefs with garters.



**Girdle displayed on a mannequin.** In the 1930s, technological innovations such as Lastex and other lightweight, easily washable stretch fabrics helped account for a boom in girdle production that, except for a brief period during World War II, lasted through the 1950s. © BETTMANN/CORBIS. REPRODUCED BY PERMISSION.

Late in the war, synthetic rubber neoprene appeared in girdles, but was overshadowed by the newly plentiful nylon and Lastex. With wartime seriousness forgotten, pink, blue, rose, black, and plaid girdles gladdened consumers' hearts. Embroidered touches, including custom sorority emblems from the new Olga Company, lent glamour to formerly stodgy foundations. The biggest news, however, came from the outerwear silhouette. American dress and girdle styles were moving tentatively toward fuller hips and smaller waists as early as fall 1945, but the 1947 French New Look took the trend much further, faster. Girdles rose in the waistline, swelled in the hip, and even returned to selective lacing to achieve the newly desired hourglass effect. American brands pursued a more moderate line, in order not to alienate customers—especially the all-important teenagers, who demanded comfort, easy care, and flexibility in their girdles.

Far longer-lasting than the New Look was the new marketing, presaged before the war by Playtex's packaging of its Living Girdles in tubes for self-service. Other

girdle and bra makers followed suit after 1945, and the old tradition of corsetieres fitting customers began a slow decline.

### 1950s' Heyday

Sheath dresses, popular periodically through most of the 1950s, kept various types of girdle in adult women's wardrobes. Many girdles sported waists as much as four inches above the natural line, supported by boning, wires, and Lastex reinforcements. Snug pants, a fashion of the mid- to late 1950s, augmented the need for long-legged pantie girdles. However, as early as 1952, hints of eased fit in some dress and suit styles foretold the coming of shift dresses in the 1960s. Blousons, Empire-waisted dresses, and the ill-fated chemise of 1957–1958 offered women escape from the stifling embrace of the sheath and its confining foundations.

During the 1950s, very short girdles and pantie girdles proliferated, designed for informal wear and appealing to older teens and young adults. Some merited the nickname "postage stamp" that Jantzen applied to its 1952 style. Some makers featured girdles proportioned for tall women. Companies tried to serve varied customers, though some, including Jantzen, Olga, and Hollywood Vassarette, specialized in a young clientele.

Young or mature, women made their complaints about girdles known, because companies repeatedly trumpeted improvements in comfort. Several firms began to cut the lower front edge in a high upward curve to reduce discomfort in walking. Sarong famously brought out a crisscrossed lower front to move with the wearer's stride. Legs of panties were redesigned for ease in wearing, and both top and bottom of the rear of the girdle were engineered to prevent riding up—a major lament. Removable, even disposable, crotches remedied the panties' laundry problems.

Throughout the decade, manufacturers trumpeted their girdles' lightness, at no sacrifice of shaping power. Girdles, like their wearers, seemed to be on a diet. Nylon in Powernet and woven materials subtracted ounces. Openwork fishnet improved ventilation—crucial in selling girdles for warm-weather wear. By 1954, Dacron polyester appeared in girdles, alone and in blends with cotton. Less-clammy textured nylon came to market under the brand names of Helanca and Ban-lon. Most successful of the weight-reducing textiles, however, was Dupont's Fiber K, which in 1959 produced a two-ounce girdle! Spandex was born.

Comfort alone did not suffice; beauty was also required. Colors proliferated—from subtle almond and pale gray to vibrant red, purple, and salmon. Individual styles came in as many as eight colors by 1957. Embroidery, lace, and appliqués gratified the desire for luxury. All of this cost money. Although \$2.95 could purchase a down-market girdle, typical prices ranged from \$5 to \$25 dollars.

Girdles reportedly contributed 39 percent to total 1956 sales dollars in foundation departments, but those sales were highly seasonal, peaking in April, September, and December, and hitting troughs in January, July, and August (*Merchants Trade Journal*, January 1957; *Merchants Trade Journal*, September 1955). Despite blandishments about comfort, women lost interest in girdles in hot weather.

### Surviving the 1960s

Like the 1920s, the 1960s had an exaggerated image of uncorseted, braless freedom. In fact, the early 1960s produced waist-hugging dresses and tight pants that drove some women to retain their girdles. Constraint was achieved by machine-washable powernets of Fiber K, christened Lycra in 1960, and joined by rivals Vyrene and Numa in the 1960s. Every girdle company used proprietary shaping in front and side panels to tame tummies and thighs. Derrieres, however, came into fashion, and girdles that uplifted the gluteus maximus moved from racy Frederick's of Hollywood into mainstream companies in the mid-1960s.

Other aspects of girdle shape evolved through the decade. Snug waists in the early 1960s were gradually replaced by dipped waists. By 1962, so-called "hip-hangers" or "hipbone pants" came into fashion, producing low-slung panty girdles. As skirts rose, girdles shortened, ending the decade at crotch level. Tights and panty hose drove girdle makers to promote their products as panty-hose mates. Taste ran to riotous colors in outerwear, and innerwear followed suit: Floral swirls, polka dots, checks, butterflies, and leopard prints enlivened girdles and coordinating innerwear.

Frantic pursuit of fashion and novelty availed little. A 1963 report showed that girdles constituted only 23.6 percent of foundation-department sales, compared with 71.8 percent for bras. Fashion reportage stressed the nude look, and played up Yves Saint Laurent's statement "underwear is dead." Despite howls from the trade press, girdles seemed to be in terminal decline. By 1970, a mere scattering of ads for panty-sized "smoothers" appeared. But fashion has taken many turns through the years, and in 2003 at least a few companies still produced nylon and spandex "body slimmers." Under such euphemisms, the girdle lives.

See also **Brassiere; Corset; Petticoat; Underwear.**

### BIBLIOGRAPHY

- "The Corset." *Fortune* (March 1938): 95–99, 110, 113, 114.  
*Corset and Underwear Review*, various issues, 1916–1969.  
*Dry Goods Merchants Trade Journal* (title varies), various issues, 1929–1959.  
*Field Sales Guide*. 1 May 1963. Maidenform Archives, Box 27, Folder 3. National Museum of American History.  
 "Girdles Contributed 39 Percent to 1956 Foundation Sales." *Merchants Trade Journal* (January 1957): 90.

*Harper's Baza(a)r*, various issues, 1935–1968.

"How Do Your Bra and Girdle Sales Compare?" *Merchants Trade Journal* (September 1944): 104.

Kops Brothers Account Record; transcript of Interview No. 6. J. Walter Thompson Archives, John Special Collections, Duke University.

*Mademoiselle*, various issues, 1940–1975.

*MaidenForm Mirror*, various issues, 1931–1966.

Picken, Mary Brooks. *The Fashion Dictionary*. New York: Funk and Wagnalls, 1957, p. 149.

*Vogue*, various issues, 1935–1975.

*Merriam-Webster's Collegiate Dictionary*. 10th ed. Springfield, Mass.: Merriam-Webster, Inc. 1980.

*Jane Farrell-Beck*

**GIVENCHY, HUBERT DE** Hubert de Givenchy was born on 21 February 1927 in Beauvais, France. The son of a prosperous family, he attended college at Beauvais and then moved to Paris. In 1944 he took a position as an apprentice designer at the couture house of Jacques Fath while studying at the École des Beaux-Arts in Paris. In the late 1940s and early 1950s he took a series of jobs as an assistant designer—first with Fath, then with Lucien Lelong, Robert Piguet, and Elsa Schiaparelli. Givenchy's years as an assistant designer encompassed the period of the New Look and perhaps instilled in him a sense of romanticism that was to characterize his work for over four decades.

Givenchy opened his own couture house in 1951 and made an immediate mark with his design of the "Bettina blouse," a simple white cotton shirting blouse named for Fath's favorite model, Bettina Graziani. Givenchy was quickly recognized as an innovative talent for his system of designing his creations—including evening gowns—as compositions of separate and interchangeable elements. In 1953 he met Cristóbal Balenciaga, who quickly became his mentor and lifelong friend. Givenchy moved his business in 1955 to 3, avenue George V, across the street from Balenciaga's atelier, and the two men were in almost daily contact thereafter. In 1954 Givenchy opened his fragrance business, Société des Parfums Givenchy. He designed his first outfits for the actress Audrey Hepburn that same year. She quickly became his most famous model and muse and looked so enchanting in his creations in a series of films—beginning with *Sabrina* in 1954 and continuing with *Funny Face* (1957), *Breakfast at Tiffany's* (1961), *My Fair Lady* (1964), and others—that she made Givenchy a household name. The designer was generous in acknowledging Hepburn's role in his career, remarking that "often ideas would come to me when I had her on my mind. She always knew what she wanted and what she was aiming for. It was like that from the very start." Givenchy also became known as one of Jacqueline Kennedy's favorite designers; he designed the dress that she wore to President Kennedy's funeral.



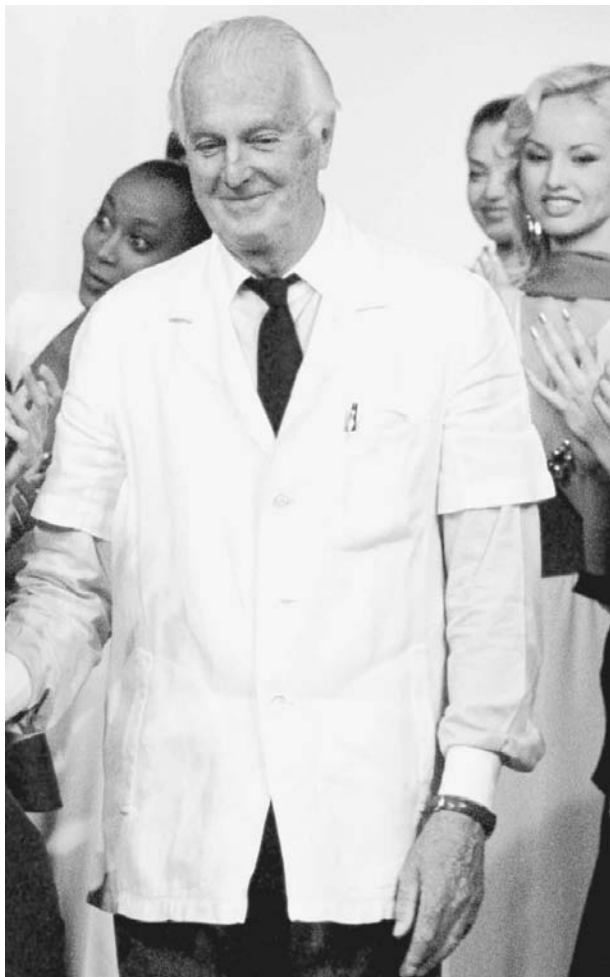

**Hubert de Givenchy at his last show, Paris, 1996.** De Givenchy was perhaps best known for designing dresses for Audrey Hepburn for a number of acclaimed film roles and for designing the dress that Jacqueline Kennedy wore to President John F. Kennedy's funeral. AP/WIDE WORLD PHOTOS. REPRODUCED BY PERMISSION.

Givenchy's style was characterized by bright cheerful colors and a youthful femininity. Yet his simple tailleurs, cocktail dresses, and evening dresses were also the height of chic, emphasizing line more than decoration. "You have to know when to stop," he once said. "That is wisdom."

Givenchy expanded his business in the late 1960s and into the 1970s to include women's ready-to-wear clothing as well as a line of menswear. He sold his company to the French luxury conglomerate LVMH in 1988 but continued to serve as head designer until his retirement in 1995. His first successor was John Galiano, who departed in 1996 and was replaced by Alexander McQueen. McQueen in turn left the company in 2001 and was succeeded as artistic director by Julien McDonald.

See also **Balenciaga, Cristóbal; Fath, Jacques; Galiano, John; McQueen, Alexander; New Look; Paris Fashion; Perfume; Schiaparelli, Elsa.**

#### BIBLIOGRAPHY

- Benbow-Pfalzgraf, Taryn, ed. *Contemporary Fashion*. 2nd ed. Farmington Hills, Mich.: St. James Press, 2002.
- Buxbaum, Gerda, ed. *Icons of Fashion: The 20th Century*. Munich, London, and New York: Prestel Verlag, 1999.
- Join-Diéterle, Catherine, Susan Train, and Marie-José Lepicard. *Givenchy: 40 Years of Creation*. Paris: Musée de la Mode et du Costume, 1991.
- Milbank, Caroline Rennolds. *Couture: The Great Designers*. New York: Stewart, Tabori and Chang, 1985.
- Mohrt, Françoise. *The Givenchy Style*. New York: Vendome Press, 1998.

*John S. Major*

**GLAZING** Glazing is a textile finish that adds luster and smoothness to the surface of the fabric. Many glazed fabrics are plain-woven cotton. A specialized calender (set of metal rollers) called a friction calender, literally rubs the fabric lustrous. Glazed chintz and polished cotton are examples of glazed fabrics.

#### The Process

The fabric is first impregnated with wax, starch, or a resin solution using a pad machine. The fabric passes through the solution in a bath, then through pad rollers. Pressure is applied so that the solution is forced into the fabric. The pressure on the pad roller squeezes the excess solution out of the fabric. The fabric is partially dried and passed through a friction calender. The friction calender is made up of three rollers. One roller is a padded roller that moves the fabric slowly between two metal rollers. As the fabric moves slowly between the rapidly moving heated metal rollers, the friction creates heat. The fast moving metal rollers polish the fabric. The glaze will be temporary if the fabric has been treated with wax or starch. The finish will be durable if the fabric has been treated with resins. The glazing will be durable on thermoplastic (heat sensitive) fiber fabrics because the friction rollers produce heat.

#### Ciré

A specialized finish, ciré (sometimes called the "wet look") is similar to glazing. The difference is that very hot rollers in the friction calender are used to add a highly lustrous surface. Again, waxes, starches, or thermoplastic resins are added to the fabric. When thermoplastic fibers are used in the ciré process the fibers slightly fuse, melt, and flatten. The ciré finish on thermoplastic fibers is permanent. When hydrophobic fiber fabrics are given a ciré finish the resultant fabric is water repellent. Typical fabrics that are ciréd are taffeta (a filament unbalanced ribbed fabric), tricot (a warp knit), and satin.

Glazing can occur accidentally when fabrics are over-pressed. Glazing occurs when a too hot iron is used on a fabric made from a fiber that is heat sensitive. The heat is not enough to melt the fabric completely but does slightly fuse and flatten the fibers. An undesirable sheen that may resemble an oil stain will appear. The damage will be permanent.

Another definition for glazing is the pressing of fur to develop a desirable sheen. The pressing aligns the hairs in the fur, thus generating a natural luster and additional softness to the fur. Often a glazing solution using a spray gun is applied.

See also **Chintz; Cotton; Fibers.**

#### BIBLIOGRAPHY

- Needles, Howard L. *Textile Fibers, Dyes, Finishes, and Process: A Concise Guide*. Park Ridge, N.J.: Noyes Publications, 1986.
- Slade, Philip E. *Handbook of Fiber Finish Technology*. New York: Marcel Dekker, 1998.

*Robyne Williams*

**GLOBALIZATION** In a certain sense, the Western economy has been “global” since the sixteenth century. After all, the African slave trade, colonialism, and the intercontinental trade in sugar and coffee made capitalism possible. But since the early 1980s, transnational corporations, cyber technology, and electronic mass media have spawned a web of tightly linked networks that cover the globe. Taken together, these forces have profoundly restructured the world economy, global culture, and individual daily lives. Nowhere are these changes more dramatic than in the ways dress and fashion are produced, marketed, sold, bought, worn, and thrown away.

For consumers in dominant Western countries, globalization means an abundance of fashions sold by giant retailers who can update inventory, make transnational trade deals, and coordinate worldwide distribution of goods at the click of a computer. It means that what people are consuming is less the clothing itself than the corporate brand or logo such as Nike, Victoria’s Secret, or Abercrombie & Fitch. Consumers are purchasing the fantasy images of sexual power, athleticism, cool attitude, or carefree joy these brands disseminate in lavish, ubiquitous, hyper-visible marketing on high-tech electronic media. But much less visible is the effect of globalization on the production of fashion.

As fashion images in magazines, music videos, films, the Internet and television speed their way around the world, they create a “global style” (Kaiser 1999) across borders and cultures. Blue jeans, T-shirts, athletic shoes and base ball caps adorn bodies everywhere from Manhattan to villages in Africa. Asian, African and Western fashion systems borrow style and textile elements from each other. Large shopping malls in wealthy countries

house all these styles under one roof. Like high-tech global bazaars, they cater to consumers of every age, gender, ethnicity, profession, and subculture.

According to Susan Kaiser, “This tendency toward both increased variety within geographic locations and a homogenizing effect across locations represents a global paradox” (Kaiser 1999, p. 110). On the one hand, shopping malls in every city have the same stores, and sell the same fashion items. Yet if we take the example of jeans, we find a seemingly infinite and often baffling array of cuts and fits: from stretched tight to billowing baggy, from at-the-waist to almost-below-the-hip; from bell-bottom to tapered at the ankle; from long enough to wear with stiletto heels to cropped below the calf. While a somewhat baggy, “relaxed” cut can signify dignified middle-aged femininity, a baggy cut taken to excess can signify hyper-masculine ghetto street smarts. Each variation takes its turn as an ephemeral and arbitrary signifier of shifting identities based on age, gender, ethnicity, or subculture.

While marketing campaigns encourage us to associate fashion consumption with pleasure, power, personal creativity, and individual fulfillment, business economists and corporate finance officers have a different view. Contrary to fashion magazines, business organs like *The Wall Street Journal* anxiously watch over consumer behavior as minutely measured by the Consumer Confidence Index managed at the University of Michigan (Weiss 2003). In this view, consumption is neither personal nor individual, but necessary for upholding a vast, intricate global capitalist economy. Dependent on massive fashion consumption in the wealthier countries, this economy depends equally on massive amounts of cheap labor in poorer countries.

#### The Global Assembly Line

No longer manufactured by the company whose label it bears, clothing from large retailers is manufactured through a network of contractors and subcontractors. Pioneered by Nike, the largest retailer of athletic shoes and fashions, the outsourcing or subcontracting system was quickly taken up by giant retail chains like Express and The Gap, and big-box stores such as Wal-Mart. These companies do not manufacture their own goods, but rather source and marketing goods produced on contract in low-wage environments. Because they make large profits, they can force manufacturers to contract with them at lower and lower prices. To reduce their costs, manufacturers subcontract much of the sewing, and even the cutting, to sweatshops in countries such as Mexico, China, Thailand, Romania, and Vietnam, where poverty is high and wages can be as low as 23 cents per hour. Manufacturers can also subcontract to sweatshops in the vast underground economies of immigrant communities in cities like Los Angeles, New York, or London. There is a huge contrast, but a tight relation, between production in sweatshops, where



**Employees making shoes at a Reebok factory, 1996.** Since the early 1980s, globalization has become an increasingly dominant force in the production of fashion goods. In the early twenty-first century, to take advantage of costs, fashion corporations outsourced much of their manufacturing to factories in countries such as China, Thailand, Mexico, and Vietnam. © MICHAEL S. YAMASHITA/CORBIS. REPRODUCED BY PERMISSION.

young women workers are often subjected to physical and sexual abuse, and consumption in retail chains filled with glamorous images. Jobs come without even the most basic worker safeguards and benefits.

Since retailers can lower their prices to consumers by lowering their labor costs, consumers have unwittingly participated in intensifying a system of competition among manufacturers that drives wages and working conditions downward. According to the World Bank, one of the most powerful institutions of globalization, “the competitive intensity of the U.S. retailing industry has increased significantly” (Biggs et al., p. 1). As a consequence, it says, “new emerging retail strategies” include “the drive to offer more value-oriented, low-priced goods to their customers, utilizing a global sourcing network that increasingly favors low wage, quota free countries,” and the “liberalization of labor regulations” (Biggs, p. 2). This “liberalization” means relaxing worker protections for health and safety, lowering and also enforcing less stringently the minimum wage, and prohibiting workers from organizing for better wages and working conditions.

### Immigrant Labor

By contrast to the World Bank’s optimism about globalization, in 1998, the California Labor Commissioner said: “Global competition results in a feeding frenzy in which local producers compete against one another and against foreign factories in a brutal race to the bottom” (Rabine, p. 118). Referring to one among countless examples of production on the global assembly line, he was speaking on the occasion of the closure of a garment factory in Los Angeles that owed its workers \$200,000 in unpaid wages. To meet a contract for T-shirts from the Disney Corporation, it had to reduce its profit margin and keep accelerating its production schedule in a downward spiral to closure.

One effect of globalization is increased immigration from third-world countries to all the countries of the world. Immigrants to the United States provide a labor pool for local versions of third-world sweatshops. In 1997, Southern California came to lead the nation in garment production. By 1999, hourly wages for garment workers in Los Angeles had dropped below minimum wage of \$5.75 to as little as \$3.00. Often workers



were not paid at all. The California Labor Commissioner estimated in 1999, right before a new anti-sweatshop law was passed, that the industry accumulated \$72,620,000 in unpaid wages to mostly immigrant garment workers.

### Responses to the Global Assembly Line

Until 1997, CEOs of the giant retailers, such as Philip Knight of Nike, claimed that they had no responsibility for the working conditions in the sweatshops because the owners were independent contractors. But by this time consumer groups, religious groups, and student groups, including the National Labor Committee in New York, Global Exchange in San Francisco, the Los Angeles Jewish Commission on Sweatshops, the national organizations of United Students Against Sweatshops and Sweatshop Watch, as well as garment workers' unions like Unite, began campaigning for reforms. By bringing publicity to the practices of the giant retailers, these groups persuaded corporations to pledge themselves to accept fair labor standards and to have independent monitors in the factories that supply their fashions. These groups have also promoted legislation in California and New York that aims to hold the retailers responsible for the wages and working conditions of the workers who produce the products they sell.

### Informal Global Networks

While the global assembly line and mass consumption form the dominant circuits of globalized fashion, other, less visible circuits span the globe. These shadow networks concern fashion production and consumption in third-world countries. The global economy of high-tech, large-scale networks also works by exclusion. In third-world countries, globalization has resulted in the destabilizing and dismantling of official economies, massive unemployment, and the rise of informal or underground economies. As part of the restructuring and deregulation of global capital, the World Bank and International Monetary Fund have imposed on debtor nations in the third world Structural Adjustment Programs. These programs dismantled state economic controls on basic necessities and social programs for health, education, housing, and sanitation, in favor of free-market strategies, austerity programs, and privatization of basic utilities like electricity and water. These measures have resulted in a disintegration of formal institutions of the government and economy. Out of desperation, people have devised means of surviving in informal economic networks. In Africa and Latin America, this has had two effects on fashion.

One is that the numbers of artisanal producers, especially tailors, dyers, weavers, and jewelry makers, have increased dramatically. In an alternative global network, suitcase vendors sell to tourists, or they travel to diasporic communities in Europe and the United States, where they sell their fashions in people's homes, at eth-

nic festivals, or on the street. They also sell in the boutiques and on the Web sites of nonprofit organizations dedicated to helping third-world artisans.

A second effect concerns global networks of used-clothing dealers and consumers. Large wholesalers buy masses of used clothing from charity thrift shops such as Goodwill in the United States, Canada, and Europe. In giant warehouses, dealers sort the clothes, bale them, and send them by container to smaller wholesalers in countries of Asia, Africa, and Latin America. Small retailers then sell the clothes for affordable prices at open-air stalls in cities and tiny rural towns. Jeans, T-shirts, and athletic shoes thus become the most visible symbol of globalization in virtually every corner of the world.

*See also* **Sweatshops; Textiles and International Trade.**

### BIBLIOGRAPHY

- Anderson, Sarah, John Cavanagh, and Thea Lee. *Field Guide to the Global Economy*. New York: New Press and the Institute for Policy Studies, 2000.
- Biggs, Tyler, Gail R. Moody, Jan-Henrik van Leeuwen, and E. Diane White. *Africa Can Compete!: Export Opportunities and Challenges for Garments and Home Products in the U.S. Market*. World Bank Discussion Papers, no. 242. Washington, D.C.: The World Bank, 1994.
- Bonacich, Edna, and Richard Appelbaum. *Behind the Label: Inequality in the Los Angeles Apparel Industry*. Berkeley: University of California Press, 2000.
- Brydon, Anne, and Sandra Niessen, eds. *Consuming Fashion: Adorning the Transnational Body*. Oxford: Berg, 1998.
- Hansen, Karen Tranberg. *Salaula: The World of Secondhand Clothing and Zambia*. Chicago: University of Chicago Press, 2000.
- Kaiser, Susan. "Identity, Postmodernity, and the Global Apparel Marketplace." In *Meanings of Dress*, edited by M. L. Damhorst, K. Miller, and S. Michelman. New York: Fairchild, 1999.
- Rabine, Leslie W. *The Global Circulation of African Fashion*. Oxford: Berg, 2002.
- Ross, Andrew, ed. *No Sweat: Fashion, Free Trade, and the Rights of Garment Workers*. New York: Verso, 1997.
- Stiglitz, Joseph E. *Globalization and Its Discontents*. New York: W. W. Norton and Company, 2002.

### Internet Resources

- Global Exchange. Available from <<http://www.globalexchange.org/campaigns/sweatshops.htm>>.
- Los Angeles Jewish Commission on Sweatshops. Available from <<http://www.pjalliance.org/SweatshopReport.pdf>>.
- National Labor Committee. Available from <<http://www.nlcnet.org.htm>>.
- Sweatshop Watch. Available from <<http://swatch.igc.org/swatch/industry/cal/.htm>>.
- United Students Against Sweatshops. Available from <<http://www.studentsagainstsweatshops.org>>.

*Leslie W. Rabine*

**GLOVES** Over time, shifts in production methods and patterns of consumption in relation to gloves have been paralleled by a shift in their primary role. Today, gloves may broadly be considered as a form of protective hand covering for use in cold weather. Within the context of fashion, gloves belong to the family of small accessories that includes fans, scarves, and hats. They are closely related to the mitten and muff. For several centuries gloves were highly symbolic garments, often worn for reasons other than protection. This changing conception illustrates the varied roles gloves have played within the discourse of fashion.

### The Origin of Gloves

Gloves have been made since ancient times. Over the course of history gloves have served both utilitarian and decorative functions. Early cave paintings depict people wearing primitive leather gloves, and gloves have also been recovered in the remains of ancient Egyptian tombs. In both instances gloves came to be out of a need for protection. Similarly, ancient Greek and Roman peoples wore gloves for protection in battle and agricultural work. Gloves have also been an indicator of social status and power. Traditionally, the clergy wore gloves while performing the sacraments. In this case they communicated the power of the church and its representatives.

The development of the European gloving industry did not begin until the tenth century, and it was not until the eleventh century that it extended throughout Britain. Originally, the use of gloves within Britain was confined to the realm of warfare. Gloves were typically made of local deer, sheep, or imported kidskins. Knights and military officials wore protective hand coverings fashioned out of linked iron. Women did not generally include gloves as part of their dress until the Reformation period. The widespread use of gloves as fashion accessories did not commence until the early seventeenth century.

### Seventeenth-Century Gloves

During the seventeenth century, fashion and status-oriented motivations for wearing gloves emerged. Within Britain the use of gloves was primarily confined to the elite social classes and signified the wearer's wealth and superior rank. Glove styles of the period were designed to complement the highly decorative and patterned styles of clothing that were in vogue. These gloves were not gender specific, and the styles worn by both sexes were almost identical in terms of shape, decoration, and color. They were typically made from deer, sheep, and kidskins in a natural color palette. As the century progressed, however, gloves became decorative garments in their own right. Gloves adorned with elaborate gold and silver silken embroideries, often bejeweled with precious stones, became popular, as did the attachment of a patterned and fringed gauntlet at the wrist. The seventeenth century also witnessed the birth of fabric and knitted gloves. However, fabric gloves did not communicate the

social status and prestige that highly decorated leather gloves and gauntlets did. These gloves were elegant, fashionable, and expensive objects of desire that often served little or no utilitarian or protective function.

This new perspective brought with it new conventions concerning the trade of gloves. The newly established connection between gloves and the social status of their wearers led to the practice of offering gloves as symbolic gifts and even methods of payment. Within courts of law judges and official dignitaries were often presented with gloves not only as payment for services but also as symbols confirming the power of the State. The value of the gifts was commonly increased by inserting gold coins into the body of the glove, or by perfuming the material.

New behaviors emerged concerning the correct etiquette for wearing and removing gloves. It was not considered appropriate, for instance, to be wearing gloves when accepting objects or in the presence of a judge. Institutions such as the courts and the church continued to regard gloves as symbolic garments. Indeed, gloves were not only worn by the clergy, but became an integral element of what was considered proper church dress.

The latter years of the seventeenth century saw the emergence of distinct men's and women's styles. Elbow-length versions in different colors became popular for women while men opted for more basic styles. It was at this time that the practice of wearing gloves began to extend to the middle classes as the range of materials and styles increased. The distinction between men's and women's gloves, the proliferation of styles, and their broadening social appeal continued into the eighteenth century.

### Eighteenth-Century Gloves

As a consequence of technical advances and new forms of fashionable dress, the consumption of fabric and knitted gloves began to increase during the eighteenth century. The lower cost of these materials meant that gloves soon became accessible to a wider section of the populace. Changing fashions, along with the high cost of elaborate gauntlet styles, led to the emergence of shorter, wrist-length gloves. Such styles were often constructed of finely embroidered and printed leather or multicolored woven cloth. Gloves of this type were designed to complement the popular fashions of long ruffled or lace-trimmed sleeves.

Toward the end of the eighteenth century, gloves no longer formed an essential part of the male wardrobe. Men's use of gloves was becoming confined to sporting pursuits. Gloves were thus employed only while riding, hunting, or driving, and styles emerged which catered specifically to these activities.

### Nineteenth-Century Gloves

The beginning of the nineteenth century saw men return to wearing gloves for reasons other than sporting. The established preference for simple, wrist-length styles for

both sexes continued throughout the early nineteenth century. Popular choices for men and women were generally constructed of pale-colored leather or white silk and cotton. The continued preference for short gloves was a consequence of the prevailing trend in clothing for long ruffled or lace-trimmed sleeves.

A clear dichotomy began to appear by the end of the century between the forms of gender-defined dress. As clothing became more elaborate for women and simplified for men, so too did the respective designs of their gloves. For women, gloves once again emerged as highly decorative fashion accessories, and specific styles were designated for day and evening wear. These were constructed either of white silk and knitted fibers or of pale-colored embroidered and finely printed leather. For men, styles became increasingly plain and well fitting. These gloves were designed to properly accompany the fine tailoring that came to dominate male dress during the early decades of the nineteenth century. For day gloves, yellow emerged as a popular color choice for men along with black, brown, and navy blue. White gloves remained de rigueur for evening wear.

By the end of the century, it became fashionable to wear tightly fitting gloves that were molded to the specific contours of the hand. Wrist-length gloves that fastened with buttons came to be worn by both sexes. For women, buttoned elbow-length evening gloves became available in a range of color and fabric variations.

The nineteenth century saw the development of social codes that prescribed the types of gloves to be worn during particular day and evening engagements. To appear in public without gloves in situations that called for glove wearing was to invite censure or ridicule. Maintaining one's gloves was also very important, as soiled gloves were reflective of poor etiquette. As pale-colored gloves were popular at the time, people had to purchase their gloves in multiple quantities and carry spare pairs with them on outings should one pair become soiled.

### Twentieth-Century Gloves

In sharp contrast to the preceding century, the twentieth century was marked by the gradual demise in the social importance of gloves. Although technological advancements made in glove production meant that greater varieties could now be made, the significant social upheaval following World War I profoundly affected the way they were consumed. After World War II, previously held standards of social etiquette concerning the wearing of gloves no longer seemed appropriate. Since clothing was rationed and became rather standardized in design, highly fashionable gloves were largely deemed unnecessary. As a consequence, gloves reverted to a more utilitarian role as garments to be used for protection against cold weather. Practical, durable styles were produced for both sexes in conservative color choices of black, brown, and navy. Leather versions were often lined with wool and fur for extra warmth.

Throughout the 1950s, however, something of a glove renaissance occurred within the realm of female fashionable dress. Styles gradually emerged that were constructed from synthetic fibers, such as satin and netting, in a wide range of colors. Women began to wear gloves that either sharply contrasted or closely matched the color of their clothing, jewelry, and other small accessories. This trend was short lived, and by the 1960s the use of gloves became increasingly less frequent, except as protection against cold weather or for work, such as gardening.

### Conclusion

The fact that gloves have been widely preserved within museum collections indicates our appreciation of the important role gloves have played throughout history. Gloves were once highly symbolic garments used to convey important social messages. Since the twentieth century, however, this has changed. Within the contemporary fashion discourse gloves assume a limited role and function. Their status has been reduced to utility and they are worn only as means of protection. It is highly unlikely that gloves will ever assume the symbolic significance they once had in the past.

*See also* Muffs.

### BIBLIOGRAPHY

- Boehn, Max Von. *Modes and Manners: Ornaments; Lace, Fans, Gloves, Walking Sticks, Parasols, Jewellery & Trinkets*. London and Toronto: J. M. Dent and Sons Ltd., 1929.
- Cumming, Valerie. *Gloves*. London: B. T. Batsford Ltd., 1982.
- Dent, Allcroft & Co. *A Brief Description of the Manufacture, History and Associations of Gloves with illustrations from Dent, Allcroft & Co's Manufactory*. Worcester, England: Worcester, Baylis, Lewis and Company.
- Ellis, Eldred B. *Gloves and the Glove Trade*. London: Pitman and Sons, 1921.
- Norton-Kyshe, J. W. *The Law and Customs Relating to Gloves*. London: Stevens and Haynes, 1901.

*Kristina Stankovski*

**GODEY'S LADY'S BOOK** *Godey's Lady's Book*, first published in Philadelphia in 1830 as *Godey's Ladies' Handbook*, was the leading women's magazine in mid-nineteenth-century America. Similar publications had been produced in Europe since the late eighteenth century and *Godey's* was closely patterned after its English and French counterparts. Several variations of the periodical's name occurred over time, including *Godey's Magazine and Lady's Book*, but the magazine is generally known by its most familiar title, *Godey's Lady's Book*.

The magazine's founder and first publisher, Louis Antoine Godey (1804–1878), provided his female audience with a wide range of articles designed to educate and entertain. *Godey's* topics included fashion, travel





**Fashion plate from *Godey's Lady's Book*, October 1852.** Founded by Louis Antoine Godey in 1830, *Godey's* was the leading women's magazine in mid-nineteenth-century America. It ceased publication in 1898. PUBLIC DOMAIN.

notes, exercise regimens, practical advice for the housewife on home decoration, recipes, gardening, and crafts, plus fiction, poetry and essays by celebrated nineteenth-century authors, such as Harriet Beecher Stowe, Edgar Allan Poe, and Nathaniel Hawthorne. In the 1850s,

*Godey's* had the highest circulation of any American women's magazine, reaching a peak of 150,000 subscriptions by the early 1860s. The periodical's success during these years was largely due to Sarah Josepha Hale (1788–1879), *Godey's* editor from 1837 to 1877. Before



coming to *Godey's*, Hale edited her own literary journal, an experience that influenced her work at *Godey's* and strengthened the magazine's content, making it more appealing than its competitors.

Fashion illustrations were part of *Godey's* from its first number. Single hand-colored fashion plates were issued until 1861, when folded double-page plates were introduced. The magazine also included descriptions of the outfits in the fashion plates, detailing fabrics, trims, and accessories. Additional uncolored plates illustrating accessories or individual garments were also found in most issues, along with needlework and craft projects, and occasionally, patterns.

*Godey's* was not the first American publication to use hand-colored fashion plates—that distinction goes to a competitor started in 1826, *Grabam's American Monthly Magazine of Literature, Art and Fashion*. The fashion plates in American magazines through the 1840s were generally inferior copies of designs that initially appeared in English or French periodicals. By the 1850s, the quality of the images improved because some of the metal engraving plates used in French publications were imported to the United States. The original captions on these plates were removed and new ones, such as “The Latest Fashions, only to be found in *Godey's Lady's Book*,” were substituted. While tactics like these obviously resulted in illustrated fashions some months behind the latest European modes, they did give *Godey's* subscribers direct contact with such styles.

Although homemakers were *Godey's* targeted audience, the magazine's fashion information and illustrations were invaluable tools for professional dressmakers in determining what was stylish and for tips in achieving the newest look. The resulting garments, however, were generally much less elaborate than those in the fashion plates. Beginning in 1870s, *Godey's* fashion influence was eclipsed by new publications like the high-style fashion magazine *Harper's Bazaar*, or others with a practical focus, such as *What to Wear and How to Make It: Madame Demorest's Semi-Annual Book of Instructions on Dress and Dressmaking*. It was also in the 1870s that *Godey* sold the magazine and Hale retired, accelerating *Godey's* decline as a quality publication. After passing through several owners, *Godey's Lady's Book* ceased publication in 1898.

See also **Fashion Illustrators; Fashion Magazines; Fashion Plates.**

#### BIBLIOGRAPHY

- Finley, Ruth Elbright. *The Lady of Godey's, Sarah Josepha Hale*. Philadelphia and London: J. B. Lippincott, 1931. Laudatory biography of the remarkable life of *Godey's* edited by Sarah Josepha Hale.
- Godey's Lady's Book*, 1830–1898. A full run of this title can be found at the Library of Congress.
- Holland, Vyvyan. *Hand Colored Fashion Plates, 1770 to 1899*. London: B. T. Batsford Ltd., 1955. A history of hand-colored fashion plates that details the uncredited use of European plates in American magazines.

Kunciov, Robert, ed. *Mr. Godey's Ladies: Being a Mosaic of Fashions and Fancies*. New York: Bonanza Books, 1971. A compendium of fashion illustrations and quotations from *Godey's Lady's Book* issues from 1830 to 1879, with an introductory history of the magazine.

Mott, Frank Luther. *A History of American Magazines*. 6 vols. Cambridge, Mass.: Harvard University Press, 1938–1968. Comprehensive history of American magazines.

Colleen R. Callahan

**GOLF CLOTHING** Although golf had existed in Scotland since the Middle Ages, as a popular game it dates to the end of the nineteenth century. The first North American golf club, founded by a Scot in Montreal in the 1870s, and soon followed by others in Quebec and Ontario, was the outcome of Scottish immigration. The earliest U.S. club was founded in Brookline, Massachusetts, in 1882. From the beginning, the clothing for golf was practical fashion wear, based primarily on the new men's sporting models appearing for use for bicycling or shooting at the time. It consisted of tweed suits with vests and, if knickers were chosen as trousers, knee-high stockings to complete the outfit. For women, who participated from the outset, a nod to practicality appeared in the slight shortening of skirts, some four to six inches off the ground, but dress for golf generally remained the clothing of the New Woman of the turn of the century: skirt, shirtwaist blouse, jacket, hat and gloves, and of course, a corset. The overall effect was conservative but comfortable for the time. It was clothing suitable for women to wear while interacting in public with men. This remained the model well into the 1920s, and indeed, given inevitable changes in design, the general tone for golf wear from that time on.

In the 1920s, Edward, Prince of Wales (later Edward VIII and duke of Windsor), influenced golf fashion with his dashing personal style, especially in his choice of traditional Fair Isle patterned knit pullover sweaters and argyle socks. The knickerbockers of the previous century were the preferred trousers at this time, but now were cut four inches longer than the older version, making them baggier at the knee; hence the name, “plus fours.” Two-colored shoes and soft-peaked tweed caps completed the look, which became the uniform of choice throughout the 1930s. Even in the early 2000s, knickers, though rare, continue to be worn. Cleated shoes then were often two-toned, much in the style of the saddle shoes that became the signature footwear of bobby-sox teenagers everywhere in the late 1930s. In addition, golf shoes often had a fringed kiltie flap that covered the laces. Bobby Jones, the Tiger Woods of his day and founder of the Masters, codified the fashion set by the Prince of Wales in the United States.

Throughout this time, women remained skirted. Tailored sports dresses that were the precursors to the shirtmaker dress emerged in the late 1920s and 1930s;

tailored separates alternated with the dresses into the post-World War II years. Skirts were in keeping with the fashions of the time, hovering around the knee in length, usually gored or relaxed with inverted tailored kick pleats front and back to allow movement and ease. They were coupled with tailored shirts and sweaters. Bermuda shorts, the sportswear darlings of the mid-1950s, hitting just above the knee and worn with knee socks, became preferred garments for both men and women at that time and continue to be worn for golf in the first years of the twenty-first century, though women usually wear them with short socks or sockees that come only to the ankle. Shorts and skorts (shorts with a skirt-like flap extending from the side seam three-quarters of the way across the front of the garment to give the appearance of a skirt) are also part of a woman golfer's wardrobe. Professional golfers, both male and female, wear long, loose, comfortable trousers or long shorts, with belt loops and belts. Most golf clubs have a policy of a collared shirt, whether woven or knit. Most frequently, these are polo shirt style. The club name or emblem is traditionally embroidered on the left breast, and it also appears on the baseball caps or sun visors that have been adopted for golf.

Most clothes for golf were practical cotton, particularly if worn in warm or moderate climates. Of course, golf fanatics who play as much as they can throughout the year, even in the north, wear layers that keep them warm, with sweaters and zipper-front waterproof jackets. With the introduction of manufactured fibers, notably polyester in the 1960s that spawned the ubiquitous "no care" polyester/cotton fabrics, golf clothes took on a more daring coloration in keeping with the fashions of the 1960s, giving golf clothing the reputation, that continues to linger, of colorful, often garish clothing that makes no attempt to be stylish. Even the greatest sartorial symbol of golf, the highly coveted Master's jacket, is a bright, unforgettable green that few would choose to wear off the links.

Overall, golf clothing might be termed fossilized fashion, becoming almost a parody of itself in its adherence to conventional forms. Golfers are stereotypically known to wear clothes that are codified by past traditions rather than new fashions. They choose outfits that are practical, loose, and pragmatic in keeping with long outdoor walks that are broken periodically by the need to swing a golf club.

Although stars such as Tiger Woods maintain a casual elegance in their golf dress, their choices still fall into the general categories of loose and comfortable. The contrast between dark conservative business suits worn during the workweek and the colorful, loose, and comfortable clothing worn for golf on the weekends has become, at the beginning of the twenty-first century, virtually a cliché.

*See also* **Sportswear.**

#### BIBLIOGRAPHY

- Armitage, John. *Man at Play Nine Centuries of Pleasure Making*. London and New York: Frederick Warne and Company, Inc., 1977.
- Chenoune, Farid. *History of Men's Fashion*. Paris and New York: Flammarion, 1993.
- Lee-Potter, Charlie. *Sportswear in Vogue since 1910*. New York: Abbeville Press, 1984.
- Tortora, Phyllis, and Keith Eubank. *Survey of Historic Costume*. 3rd ed. New York: Fairchild Publications, 1998.

*Patricia Campbell Warner*

**GORE-TEX.** *See* **Techno-Textiles.**

**GOTHS** Having emerged in the wake of punk during the 1980s, the contemporary goth scene has existed for more than two decades, as a visually spectacular form of youth culture, whose members are most immediately identified by the dark forms of glamour displayed in their appearance.

#### **Goth or Gothic Revival?**

Extensive links are sometimes drawn between goth style and various "gothic" movements and individuals throughout history associated with themes such as elegance, decadence, and death. Gavin Baddeley has detailed a linear progression of gothic culture that ends with present-day goths, having journeyed through twentieth century horror genres in television and cinema, through various examples of literature and fashion from the preceding two hundred years and finally back to the "grotesque" art and sculpture credited to the original fourth century goths. The notion that what is known as goth fashion in the early 2000s is merely the latest revival of a coherent centuries-old tradition has undoubtedly appeal and convenience, even to some enthusiasts for the subculture. The reality, though, is that they owe a greater debt to post-1960s developments in popular music culture than to literary, artistic, or cinematic traditions.

#### **Origins**

A selection of British bands that appeared prior to, during, and after the late 1970s punk era set the tone for the goth subculture that was to emerge. Crucial ingredients were provided by the deep-voiced feminine glamour of David Bowie, the disturbing intensity and eclecticism of late 1970s Iggy Pop, and the somber angst-ridden despair of Joy Division. The key direct founders of goth, though, were former punks Siouxsie and the Banshees, whose style began to take on a decidedly sinister tone toward the early 1980s, and Bauhaus, whose self-conscious emphasis upon funereal, macabre sounds and imagery was epitomized in the now legendary record "Bela Lugosi's Dead." As the dark, feminine appearance and imagery associated with such bands began to be taken up by their



fans, the new “scene” received extensive coverage in the music press. By the mid-1980s, the deep vocals, jangling guitars, and somber base lines of The Sisters of Mercy alongside black clothes, long coats, and dark shades, had established them as the archetypal “goth rock” band. A period of chart success for the Sisters, alongside The Mission, Fields of the Nephilim, The Cure, and Siouxsie and the Banshees, would ensure that toward the end of the 1980s goth enjoyed significant international exposure. Through the 1990s, however, the subculture existed in a rather more underground form, with occasional moments of mass exposure provided by high-profile artists such as Marilyn Manson and through the borrowing of goth style by emerging metal genres and, intermittently, by major fashion labels.

### Horror Fiction

Consistent with this emphasis upon sounds and appearances emerging from the music industry, the goth scene has consistently been focused, first and foremost, around a blend of music, fashion, pubs, and nightclubs. As such, it would be more usefully seen in the context of punk, glam, skate, and other contemporary style subcultures, than that of ancient tribes or nineteenth-century poets. Yet this should not be taken to imply that previous “gothic” movements are somehow irrelevant here. Most notably, it is clear that goth musicians and fans have drawn—sometimes “ironically,” sometimes not—upon imagery associated with horror fiction in both literary and cinematic forms. Beyond a general emphasis upon black hair and clothing, this has manifested itself, for both males and females, in the form of ghostly white faces offset by thick dark eyeliner and lipstick. As if the vampire link were not clear enough, some have sported even more overt signifiers, from crosses to bats, to plastic fangs. For others, there has been a tendency to adapt elements of the traditional bourgeois fashions associated with vampire fiction, something often mediated through the wardrobes of such cinema blockbusters as *Bram Stoker’s Dracula* (1992) and *Interview with the Vampire* (1994). Obvious examples here would include corsets, bodices, and lacy or velvet tops and dresses. Furthermore, although it is seldom regarded as pivotal to subcultural participation, many goths enjoy directly consuming and discussing horror fiction in both its literary and cinematic forms.

### Contemporary Influences

Yet there is more to goth fashion than this. The subculture’s emphasis upon the somber and the macabre has been accompanied by consistent evidence of other themes that fit rather less neatly with the notion of a linear long-term history of gothic. For example, an emphasis upon particular forms of femininity, for both sexes, goes far beyond the macabre angst and romanticism associated with vampire fiction. Notably, for some years, PVC skirts, tops, corsets, and collars have been among the most popular styles of clothing for goths of both genders, something that borrows more from the contemporary fetish scene



**Goth clothing.** Inspired by the somber and the macabre, goth fashion in the late twentieth and early twenty-first centuries owed much to horror fiction and punk/glam icons such as David Bowie, Joy Division, and Siouxsie and the Banshees. COPYRIGHT SARAH LOUISE HODKINSON, 2003. REPRODUCED BY PERMISSION.

than it does from traditional gothic fiction. Links with fetishism, punk, and rock culture more generally can also be demonstrated by the consistent display of facial piercing, tattoos, dyed hair, and combat pants by goths. Indeed, one of the most popular types of clothing among goths has consistently been T-shirts displaying band logos, something distinctive to the goth scene in the specific artist name and design, but otherwise comparable with other music cultures. During the course of the 1990s, another contemporary influence from music culture established itself as central to the evolving goth style, particularly in Europe. In search of new directions in which to take a well-established set of looks and sounds, bands and their fans increasingly began to appropriate and adapt elements of dance culture into the goth sound and appearance. In addition to the incorporation of mechanical dance beats and electronic sequences into otherwise gloom-ridden, sinister forms of music, “cybergoth” involved the juxtaposition of more established elements of goth fashion with reflective or ultraviolet-sensitive clothing, fluorescent makeup, and braided hair extensions.

### Distinctiveness and Identity

In spite of its variety of influences, goth fashion is a contemporary style in its own right, which has retained significant levels of consistency and distinctiveness for over two decades. Put simply, since the mid 1980s, goths have always been easily recognized as such, both by one another and by many outsiders to their subculture. Attempts to interpret their distinctive appearance as communicating a morbid state of mind or a disturbed psychological makeup are usually misplaced. What *is* symbolized,

GRÈS, MME.

though, is a defiant sense of collective identity, based upon a celebration of shared aesthetic tastes relating primarily to music, fashion, and nightlife (Hodkinson 2002).

See also **Occult Dress; Punk; Street Style; Subcultures.**

#### BIBLIOGRAPHY

- Baddeley, Gavin. *Goth Chic: A Connoisseur's Guide to Dark Culture*. London: Plexus, 2002.
- Hodkinson, Paul. *Goth: Identity, Style and Subculture*. Oxford: Berg, 2002.
- Mercer, Mick. *Gothic Rock Black Book*. London: Omnibus Press, 1988.
- . *Gothic Rock: Everything You Wanted to Know but Were Too Gormless to Ask*. Birmingham: Pegasus, 1991.
- Thompson, Dave. *The Dark Reign of Gothic Rock*. London: Helter Skelter, 2002.

*Paul Hodkinson*

**GRÈS, MME.** Madame Alix Grès is widely regarded as one of the most brilliant couturiers of the twentieth century. She employed innovative construction techniques in the service of a classical aesthetic, creating her hallmark “Grecian” gowns as well as a wide range of simple and geometrically cut designs based on ethnic costume. Her garments are noted for their three-dimensional, sculptural quality.

Mme. Grès’s life, like the creation of her gowns, was unconventional. Born Germaine Emilie Krebs on 30 November 1903 in Paris, France, she became a couturier after her bourgeois Catholic parents discouraged her desire to pursue a career first as a professional dancer and then as a sculptor. Around 1933, during a brief apprenticeship of three months at the couture house of Premet, she learned the basics of dressmaking and changed her first name to Alix. That same period she began to work for a couturier named Julie Barton, who renamed her house Alix to reflect the astounding success of her assistant.

On 15 April 1937 Grès married a Russian-born painter, Serge Anatolievitch Czerefkow. It was then that she became Alix Grès, Grès being an anagram of her husband’s first name, which he used to sign his paintings. In August 1939 their only child, Anne, was born. Months earlier, however, Serge had left France and relocated to Tahiti.

In the spring of 1940 the Nazis occupied Paris. After a falling out with Barton, Grès fled the city, like many other Parisians, and moved south with her infant daughter. The one enduring legacy of her exile was the donning of a turban; she took to wearing the headdress initially because she could not go to a hairdresser. It became her personal trademark.

In 1941 Grès returned to Paris and opened her own salon. After refusing to accommodate the Nazi’s insistence that she reveal her trade secrets and adhere to the

regime’s fabric restrictions, she was forced to close the shop in January 1944. Finally, in the early summer of 1944, she was authorized to resume her business in time to show a final collection before the liberation of Paris. This now legendary group of garments was made using only the red, white, and blue of the French flag.

The most famous and recognizable design of Mme. Grès was her classically inspired floor-length, pleated gown. In the 1930s these “Grecian” garments were primarily white in color, made from uncut lengths of double-width matte silk jersey, most often sleeveless, and cut to enhance the female body without physically restricting its movement. By the onset of World War II, because of textile restrictions, Grès focused on the manipulation of the bodices, sleeves, and necklines of much shorter garments.

In the late 1940s Grès resumed the use of larger quantities of fabric as well as a tighter and finer style of pleating. She also employed inner reinforcement or corseting. By the 1970s Grès has eliminated the corset and, simultaneously, cut away portions of the bodice, thus exposing large areas of the nude torso.

In the 1950s and 1960s Mme. Grès’s business and her designs thrived. She engaged in several licensing agreements, the most successful of which was her perfume, Cabochard, released in 1959. Literally meaning “pigheaded,” it describes the tenacity of the couturier. Madame Grès’s ethnic-inspired garments were an important part of her oeuvre during this time. Non-Western art was a major source of inspiration to her beginning in the 1930s, with the proliferation of exhibitions and expositions that displayed the products of France’s colonies. Although her output of such garments was to drop off significantly during the 1940s and 1950s, she responded to a strong revival of ethnic influences during the mid-1960s, creating caftans, capes, and pajamas for “couture hippies.” These gowns were different from her prewar creations in that Grès relied on construction techniques she observed in non-Western dress. This change occurred after a 1959 trip to India, where Grès studied ethnic costume and took note of Eastern cultures’ aversion to the cutting of textiles. She also experimented with fabrics, using faille and brocaded silks as well as more pliable materials such as fine wool knits and djersakasha, a cashmere jersey that could be woven as a tube, eliminating the need for seams.

In 1972 Mme. Grès was unanimously elected president of the *Chambre Syndicale de la Couture*. Four years later she became the first recipient of the *Dé d’Or* (Golden Thimble award), the highest honor given by the *Chambre Syndicale*. By the mid-1980s, however, the house of Grès had fallen into decline. After entrusting both her business and her trademark to a businessman-cum-politician named Bernard Tapie, Grès lost both. In April 1986 *Maison Grès* was expelled from the *Chambre Syndicale* for nonpayment of dues. Difficulties continued until the official retirement of Madame Grès, after the

presentation of her 1988 spring/summer collection. The exit of one of the greatest figures in the world of haute couture took place quietly, with no official press release from the house of Grès. She died in the south of France on 13 December 1994.

No figure in French couture used the elements of classicism so completely or so poetically as Madame Grès, who used this aesthetic in her creation of seemingly limitless construction variations on a theme. Often referred to as the great “sculptress” of haute couture, Grès used the draping method to create her most dramatic designs, often consisting of puffed, molded, and three-dimensionally shaped elements that billowed and fell away from the body. Examples included capes made with yards of heavy wool manipulated into deep folds, taffeta cocktail dresses that combine finely pleated bodices balanced with full balloon-shaped skirts puffed sleeves, and evening gowns with enormous circular sleeves and trains that could rise like sails. Although volumetric, her sculpted garments are supple and pliable and have no reinforcement such as an attached inner facing. The end result was sensual fashions that stood away from the body rather than falling next to it.

See also **Ethnic Style in Fashion; Haute Couture.**

#### BIBLIOGRAPHY

- Aillaud, Charlotte. “Legend: Madame Grès.” *Architectural Digest* (August 1988).
- Ardisson, Thierry, and Jean Luc Maitre. “The Greatness of Grès.” *Interview* (February 1981).
- Brantley, Ben. “Mme. Grès on Finely Chiseled Couture.” *Women’s Wear Daily* 7 (November 1979).
- Charles-Roux, Edmond. “Madame Grès, a Romantic View without Nostalgia.” *Vogue* (September 1964).
- Cooper, Arlene. “How Madame Grès Sculpts with Fabric.” *Threads Magazine* (April/May 1987).
- Hata, Sahoko, ed. *L’Art de Madame Grès*. Tokyo: Bunka Publishing Bureau, 1980.
- Hollander, Anne. “A Sculptor in Fabric.” *Connoisseur* (August 1982).
- “Madame Grès, Hellène de Paris.” *Jardins des Modes* (December 1980–January 1981).
- Nemy, Enid. “Timeless Styles by Madame Grès.” *New York Times* (10 October 1979).
- Villiers le Moy, Pascale. “The Timeless Fashions of Madame Grès.” *Connoisseur* (August 1982).

Patricia Mears

**GRUNGE** The term “grunge” is used to define a specific moment in twentieth-century music and fashion. Hailing from the northwest United States in the 1980s, grunge went on to have global implications for alternative bands and do-it-yourself (DIY) dressing. While grunge music and style were absorbed by a large youth



**Nirvana singer/guitarist Kurt Cobain, Seattle, Washington, 1990.** Fueled by a back-to-basics ethic, the grunge movement started in the Pacific Northwest in the late 1980s. Its simple way of dress became a fashion phenomenon after the multi-platinum success of bands like Nirvana, Pearl Jam, and Soundgarden. © S.I.N./CORBIS. REPRODUCED BY PERMISSION.

following, its status as a self-conscious subculture is debatable. People who listened to grunge music did not refer to themselves as “grungers” in the same way as “punks” or “hippies.” However, like these subcultures, grunge was co-opted by the music and fashion industries through its promotion by the media.

#### Grunge Music

The word “grunge” dates from 1972, but did not enter popular terminology until the birth of the Seattle sound, a mix of heavy-metal, punk, and good old-fashioned rock and roll, in the late 1980s. Many musicians associated with grunge credit their exposure to early punk bands as one of their most important influences.

Like San Francisco in the 1960s, Seattle in the 1980s was a breeding ground for music that spoke to its youth. The independent record label Sub Pop recorded



many of the Seattle bands inexpensively and was partly responsible for their garage sound. Many of these bands went on to receive international acclaim and major record label representation, most notably The Melvins, Mudhoney, Green River, Soundgarden, Malfunkshun, TAD, and Nirvana. Nirvana's second album, *Nevermind*, was released in 1991, making Nirvana the first of this growing scene to go multiplatinum and Kurt Cobain, Nirvana's lead singer, the reluctant voice of his generation.

### (Sub)Cultural Context

The youth movements most often associated and compared to grunge—hippie and punk—were driven both by music and politics. Punks and hippies used music and fashion to make strong statements about the world and are often referred to as “movements” due to this political component. While the youth of 1980s Seattle were aware of politics, grunge was fueled more by self-expression—sadness, disenchantment, disconnectedness, loneliness, frustration—and perhaps was an unintentional movement of sorts. There does not appear to have been a common grunge goal, such as punk's “anarchy” or the hippies' “peace.” Despite this lack of unifying intentionality, grunge gave voice to a bored, lost, emotionally neglected, post-punk generation—Generation X.

### Grunge Fashion

If punk's antifashion stance can be interpreted as “against fashion,” then that of grunge can be seen as “nonfashion.” The grunge youth, born of hippies and raised on punk, reinterpreted these components through their own post-hippie, post-punk, West Coast aesthetic. Grunge was essentially a slovenly, thoughtless, uncoordinated look, but with an edge. Iconic items for men and women were ripped and faded jeans, flannel shirts or wool Pendletons layered over dirty T-shirts with outdated logos, and black combat-style boots such as Dr. Martens. Because the temperature in Seattle can swing by 20 degrees in the same day, it is convenient to have a wool long-sleeved button-down shirt that can be easily removed and tied around one's waist. The style for plaid flannel shirts and wool Pendletons is regional, having been a longtime staple for local lumberjacks and logging-industry employees—it was less a fashion choice than a utilitarian necessity.

The low-budget antimaterialist philosophy brought on by the recession made shopping at thrift stores and army surplus outlets common, adding various elements to the grunge sartorial lexicon, including beanies for warmth and unkempt hair, long underwear worn under shorts (in defiance of the changeable weather), and cargo pants. Thrift-store finds, such as vintage floral-print dresses and baby-doll nightgowns, were worn with oversized sweaters and holey cardigans. Grunge was dressing down at its most extreme, taking casualness and comfort dressing to an entirely new level.

### Grunge Chic

The first mention of grunge in the fashion industry was in *Women's Wear Daily* on 17 August 1992: “Three hot looks—Rave, Hip Hop and Grunge—have hit the street and stores here, each spawned by the music that's popular among the under-21 set.” The style that had begun on the streets of Seattle had finally hit New York and was heading across the Atlantic. Later that same year, Grace Coddington (editor) and Steven Meisel (fashion photographer) did an eight-page article and layout for *Vogue* with the help of a Sub Pop cofounder and owner Jonathan Poneman: “Flannels, ratty tour shirts, boots, and baseball caps have become a uniform for those in the know, and their legions are growing” (p. 254). The fashion machine was drawn to the utilitarian aspects of grunge as well as the juxtapositions of textures and the old against the new. Marc Jacobs is credited with bringing grunge to the runway with his spring 1993 collection for Perry Ellis. He was later followed by such designers as Calvin Klein, Christian Francis Roth, Armani, Dolce & Gabbana, Anna Sui, and Versace who all came out with layered and vintage looks made out of luxury fabrics.

Ultimately, grunge failed as a high-fashion trend because its vitality came from the unique and personal art of combining clothes and accessories from wildly disparate and idiosyncratic sources. Grunge was not easily repackaged and sold to the people who related to it because it was out of their price range and the upscale consumer was not taking the bait. Where grunge worked well was at low to moderate price points as middle-class kids across America were buying pre-ripped jeans, beanies, and flannels all the while dancing to Nirvana.

### Post-Grunge World

Repackaging was also the fate of grunge music as every major record label tried to find the next Nirvana, and bands like Pearl Jam and Bush filled stadiums but paid little homage to grunge's punk roots. Nevertheless, grunge ultimately managed to revive rock and roll, redefine the music of the 1990s by bringing the focus back to the guitar, and make the word “alternative” meaningless in the twenty-first century as alternative music is now the music of the masses.

What grunge did for music it also did for fashion. Grunge opened the door to recycled clothes for everyone as a fashionable, and even a chic, choice. Grunge defined a new approach to dressing that included layering and juxtapositions of patterns and textures. The DIY approach to dress has become the norm, giving the consumer the freedom to choose, to not be a slave to one look or designer, and the confidence to create personal ensembles with the goal of self-expression through style.

See also **Hip-hop Fashion; Hippie Style; Punk; Street Style; Subcultures.**

## BIBLIOGRAPHY

- Coddington, Grace. "Grunge and Glory." *Vogue* (December 1992): 254–263.
- de la Haye, Amy, and Cathie Dingwall. *Surfers, Soulies, Skinheads, and Skaters: Subcultural Style from the Forties to the Nineties*. London: V&A Publications, 1996.
- Polhemus, Ted. *Street Style: From Sidewalk to Catwalk*. London: Thames and Hudson, Inc., 1994.
- Sims, Joshua. *Rock/Fashion*. London: Omnibus Press, 1999.
- Steele, Valerie. *Fifty Years of Fashion: New Look to Now*. New Haven, Conn., and London: Yale University Press, 1997.

*Shannon Bell Price*

**GUCCI** From modest beginnings at the end of the nineteenth century, the Gucci company became one of the world's most successful manufacturers of high-end leather goods, clothing, and other fashion products. As an immigrant in Paris and then London, working in exclusive hotels, young Guccio Gucci (1881–1953) was impressed with the luxurious luggage he saw sophisticated guests bring with them. Upon returning to his birthplace of Florence, a city distinguished for high-quality materials and skilled

artisans, he established a shop in 1920 that sold fine leather goods with classic styling. Although Gucci organized his workrooms for industrial methods of production, he maintained traditional aspects of fabrication. Initially Gucci employed skilled workers in basic Florentine leather crafts, attentive to finishing. With expansion, machine stitching was a production method that supported construction.

Together with three of his sons, Aldo, Vasco, and Rodolfo, Gucci expanded the company to include stores in Milan and Rome as well as additional shops in Florence. Gucci's stores featured such finely crafted leather accessories as handbags, shoes, and his iconic ornamented loafer as well as silks and knitwear in a signature pattern. The Gucci loafer is the only shoe in the collection of the Museum of Modern Art in New York.

The company made handbags of cotton canvas rather than leather during World War II as a result of material shortages. The canvas, however, was distinguished by a signature double-G symbol combined with prominent red and green bands. After the war, the Gucci crest, which showed a shield and armored knight surrounded by a ribbon inscribed with the family name, became synonymous with the city of Florence.



**Gucci clothing and accessories for sale.** The Gucci company, which began as a single Italian leather goods shop founded in 1920, expanded to become one of the most successful international purveyors of fashion © JACQUES M. CHENET/CORBIS. REPRODUCED BY PERMISSION.

Aldo and Rodolfo Gucci further expanded the company's horizons in 1953 by establishing offices in New York City. Film stars and jet-set travelers to Italy during the 1950s and 1960s brought their glamour to Florence, turning Gucci's merchandise into international status symbols. Movie stars posed in Gucci's clothing, accessories, and footwear for lifestyle magazines around the world, contributing to the company's growing reputation.

Gucci's distinctive lines made its products among the most frequently copied in the world in the early 2000s. Pigskin, calf, and imported exotic animal skins were subjected to various methods of fabrication. Waterproof canvas and satin were used for evening bags. Bamboo was first used to make handbag handles by a process of heating and molding in 1947, and purses made with a shoulder strap and snaffle-bit decoration were introduced in 1960. In 1964 Gucci's lush butterfly pattern was custom-created for silk foulards, followed by equally luxuriant floral patterns. The original Gucci loafer was updated by a distinctive snaffle-bit ornament in 1966, while the "Rolls-Royce" luggage set was introduced in 1970. Watches, jewelry, ties, and eyewear were then added to the company's product lines. A particularly iconic touch, introduced in 1964, was the use of the double-G logo for belt buckles and other accessory decorations.

The company prospered through the 1970s, but the 1980s were marked by internal family disputes that brought Gucci to the brink of disaster. Rodolfo's son Maurizio took over the company's direction after his father's death in 1983, and dismissed his uncle Aldo—who eventually served a prison term for tax evasion. Maurizio proved to be an unsuccessful president; he was compelled to sell the family-owned company to Investcorp, a Bahrain-based company, in 1988. Maurizio disposed of his remaining stock in 1993. Tragically, Maurizio was murdered in Milan in 1995, and his former wife, Patrizia Reggiani, was convicted of hiring his killers. Meanwhile, the new investors promoted the American-educated Domenico De Sole from the position of family attorney to president of Gucci America in 1994 and chief executive in 1995.

The company had previously brought in Dawn Mello in 1989 as editor and ready-to-wear designer in order to reestablish its reputation. Well aware of Gucci's tarnished image and the value of its name brand, Mello hired Tom Ford in 1990 to design a ready-to-wear line. He was promoted to the position of creative director in 1994. Before Mello returned to her post as president of the American retailer Bergdorf Goodman, she initiated the return of Gucci's headquarters from the business center of Milan to Florence, where its craft traditions were

rooted. There she and Ford reduced the number of Gucci products from twenty thousand to a more reasonable five thousand.

Tom Ford came to the foundering company with vision and style. Having the strong support of Domenico De Sole, Ford wished to maintain a sense of the company's history while updating Gucci's trademarks. In 1994 Ford became responsible for creative direction, and by 1996 he directed all aspects of the company—including ready-to-wear clothing, visual merchandising, packaging, interior design, and advertising. Ford and De Sole struggled to restore the former reputation of Gucci, while redirecting the growing brand to a new level for the market of the late 1990s.

There were seventy-six Gucci stores around the world in 1997, along with numerous licensing agreements. Ford was instrumental in the process of decision-making with De Sole when the Gucci Group acquired Yves Saint Laurent Rive Gauche, Bottega Veneta, Boucheron, Sergio Rossi, and, in part-ownership with Stella McCartney, Alexander McQueen and Balenciaga. By 2001 Ford and De Sole shared the responsibility for major business decisions, while Ford concurrently directed design at Yves Saint Laurent as well as at Gucci.

The French conglomerate Pinault-Printemps-Redouté, however, gained ownership of 60 percent of the Gucci Group's stock in 2003. *Women's Wear Daily* then announced the departure of both Domenico De Sole and Tom Ford from the Gucci Group when their contracts expired in April 2004. The last spring collection under the direction of Ford and De Sole was a critical and commercial success. Amid widespread speculation in the fashion press about Ford's heir, the company announced in March 2004 that he would be replaced by a team of younger designers promoted from the ranks of the company's staff.

*See also* Brands and Labels; Ford, Tom; Italian Fashion; Leather and Suede; Saint Laurent, Yves; Shoes.

#### BIBLIOGRAPHY

- Bianchino, Gloria, et al., eds. *Italian Fashion*. Vol. 1, *The Origins of High Fashion and Knitwear*. Milan: Electa SpA, 1987.
- Forden, Sara Gay. *The House of Gucci: A Sensational Story of Murder, Madness, Glamour, and Greed*. New York: William Morrow, 2000.
- Horyn, Cathy. "Tom Ford Goes Out with a Roar." *New York Times*, 26 February 2004.
- Steele, Valerie. *Fashion, Italian Style*. New Haven, Conn.: Yale University Press, 2003.

*Gillian Carrara*





**HAIR ACCESSORIES** Hair accessories are functional or ornamental objects wrapped, tied, twisted, inserted, or otherwise attached to the hair. Throughout history, types of ornamentation and the materials from which they were made indicated religious significance, social class, age group, and level of fashion awareness. Infinitely varied in shapes, sizes, and materials, examples of hair accessories include: hair rings or bands, ribbons and bows, hairpins, hair combs, barrettes, beads, thread or string, hair spikes and sticks, and other affixed miscellaneous objects (shells, jewels, coins, flowers, feathers) perceived to have aesthetic or social and cultural value. Hair accessories have been worn by people of all ages and by both genders.

Hair rings and hair bands are cylindrically shaped hair accessories wound around the hair, designed to hold hair away from the face, or otherwise confine strands of hair. Some of the earliest hair rings were found in Great Britain, France, and Belgium at the end of the Bronze Age. These objects were solid gold or gold-plated clay, bronze, or lead. Ancient Egyptians wore similar rings during the New Kingdom Dynasties 18–20. Examples have been found in Egyptian tombs. Worn in wigs rather than hair, these hair rings were made of alabaster, white glazed pottery, or jasper, and were a sign of social ranking or authority (*Antiquity* 1997). In North America, hair binders were made of pliable materials such as silk or cotton covering lead wire (Cox 1966). In the twentieth century, the use of rubber and other manufactured elastomeric fibers made hair rings (now called hair bands or ponytail holders) more flexible. They were covered with thread or fibers to make them less likely to break strands of hair. “Scrunchies” were some of the most popular hair bands during the 1980s. These fabric-covered elastic decorative bands were used to create ponytails in the hair of young girls and women (Tortora and Eubank 1998).

Ribbons and bows are narrow fabric strips of closely woven yarns or braid wrapped and knotted around the hair, also used to bind the hair. They were especially popular during the seventeenth and eighteenth centuries in Europe. In the 1600s in France, ribbons were worn by women of all ages, from young girls to elderly dowager duchesses, and were specifically chosen to color coordinate with their dresses (Trasko 1994). Fashionable men also adorned their long tresses with ribbons and

bows. A “love lock” was a lock of a man’s hair grown longer than the rest, and then accentuated with a ribbon (Tortora and Eubank 1998). During the 1700s in France and England, both a man’s queue (a lock or pigtail on a wig) and women’s elaborate coiffures were decorated with ribbons and bows. In Mexico in the early 2000s, women in Venustiano Carranza and San Pablito intertwine their hair with brilliantly colored rayon ribbons, woolen cords with pom-poms and beading, and hand-woven tapes (Sayer 1985).

Hairpins are single-pointed pins used to dress or fasten the hair. They serve both a functional and decorative purpose, as in central Africa where copper, wood, ivory, and bone hairpins are used to fasten the hair (Sagay 1983). The elaborate hairstyles worn by ancient Roman women were often set with long hairpins hollow enough to double as containers for perfume or even poison. In Japan, during the seventeenth century, hair ornaments of lacquered wood or tortoiseshell began to be used. The *kanzashi* (a hairpin with a decorative knob, tassel, or bead on the end) was worn by fashionable courtesans. In fact, a conspicuous mark of a courtesan during this time was her “dazzling array of hair ornaments, radiating like a halo from an often dramatically sculptured coiffure” (Goodwin 1986, Introduction). Other Japanese women wore hairstyles decorated much more simply, perhaps with a floral or pendant hairpin (Goodwin 1986). Hairpins were also necessary for maintaining a fastidious appearance in France during the late 1600s. The large “periwigs” worn by men required them to shave their head or pin their hair tightly to the head. The use of *bobbing pins* included both large, straight pins and U-shaped hairpins. The “bobbed” hair then allowed the wig to be donned more easily, as well as confined the underlying hair to present a neat, well-groomed appearance (Trasko 1994). Hairpins continued in popularity as a means of fastening long hair into chignons. According to Trasko (1994), it was considered indecent for Victorian women to be seen with an abundance of loose, streaming hair. She states, “Hairstyles continued to be as constrained as women’s lives” (p. 102). In the early twentieth century, hairpins were also necessary for creating waves in the hair (marcel waves during the 1920s) and pin curls in the 1940s. During the 1920s the bobby pin, with its tight spring clip, replaced the older style (open hairpins) allowing women to bob

their hair more effectively under tight-fitting cloche hats (Tortora and Eubank 1998).

Barrettes are metal pins approximately three inches long with a beaded head and guard cap, used to secure the hair. Some of the first barrettes were used during the mid-nineteenth century. This bar-shaped hair accessory typically has a decorative face with an underlying spring clip to fasten to the hair (Cox 1966). Often made of metal or plastic in a variety of colors, this hair clip could be viewed as a modified version of the bobby pin, combining the pin's functionality with a more decorative outer appearance. And the appeal is not solely Western. In Mexico, Totonac and Tzeltal girls who live near Papantla and Ocosingo, wear a colorful array of plastic slides and ornamental hair combs (Sayer 1985).

Headbands are hair accessories that also go back to ancient times, and combine aesthetics and functionality. As early as 3500 B.C.E., Mesopotamian men and women wore fillets or headbands to hold their hair in place. These circlets were placed on the crown of the head. In the Middle Ages, royal European ladies wore fillets of metal in the shape of a crown or coronet with various types of veils. Metal fillets gradually lost favor and were replaced by strips or bands of fabric (Tortora and Eubank 1998). During the neoclassical revival of the early 1800s, women imitated ancient Greek hairstyles by holding back their hair with fabric bands. As hats and bonnets became more fashionable in the mid-to-late 1800s, headbands lost popularity (Trasko 1994). It was not until the 1920s that headbands reappeared, when women began wearing headache bands for evening events. These bands were often ornamented with jewels or had tall feathers attached to them. Contemporary headbands often have a plastic U-shaped core covered in foam or fabric. These headbands fit closely over the top of the head and behind the ears. They emerged onto the fashion scene once again in the late 1980s and early 1990s, when the First Lady Hillary Clinton began wearing them during and after her husband's election in 1992 (Tortora and Eubank 1998).

Men as well as women wore headbands. During the Jin Dynasty (1139–1163 C.E.), Chinese men tied their long hair up with a silk band (Xun and Chunming 1987). In Mexico during the sixteenth century, priests on the Yucatan Peninsula wore bark cloth headbands. The practice continues in present-day ceremonies. Red bark cloth headbands, known as “god-hats,” are wrapped around the heads of worshipers (Sayer 1985). For everyday purposes, hair adornments are rare among male Mexicans, who have followed the Western lead for “civilized” haircuts (Sayer 1985, p. 204). However, there are exceptions. Older men from Amatenango occasionally wear factory-made bannanna handkerchiefs (known as *paliacates*) to tie back their hair from their faces. The Huichol wear a headband of purchased cotton cloth called a *coyera* to fasten their hairstyle in place. The narrow folded headband is wrapped about the head with the ends trailing and is often wound with ribbons or decorated with safety pins (Sayer 1985).

Hair combs have been used since the Stone Age to confine and decorate the hair. Boxwood combs, dating back to 10,000 B.C.E. have been found as some of the earliest hair ornaments (*Antiquity* 1997). Ancient Roman women set their hair with tortoiseshell combs. In China during the Tang Dynasty (621 C.E.–907 C.E.), women held their buns in place with decorative golden and emerald hairpins or combs made of rhinoceros horn (Xun and Chunming 1987). During the Song Dynasty (960–1279 C.E.), hairpins and combs were made into elaborate shapes of phoenixes, butterflies, birds, and flowers pinned on top of women's buns. Around the twelfth year of the Republic, Chinese women began wearing an extremely elaborate hair accessory called a “coronet comb.” The coronet was made of painted yarn, gold, pearls, silver, or jade, and had two flaps hanging over the shoulders. A long comb, nearly one foot long and made of white horn, was placed on top. The arrangement required the wearer to turn her head sideways if passing through a door or entering a carriage (Xun and Chunming 1987). During the seventeenth century in Japan, tortoiseshell or lacquered wood combs embellished with gold or mother-of-pearl were worn by fashionable courtesans, who often combined them with *kanzashi* (decorative hairpins). During the nineteenth century, women often used hair combs decorated with gemstones or “paste” (imitation) jewels. The twentieth century saw the continued use of hair combs for long hair, made of a variety of new manufactured materials such as celluloid and plastics. Hair combs also were used to attach small hats and veils to the head during the 1950s. The 1980s created new forms of hair combs, including a circular-shaped hair comb that acts like a headband and the large double-sided comb called a “banana clip” that fastened women's hair into a ponytail.

Beads used as a decorative means of accentuating plaited hair have long been worn by cultures in Africa. Cornrowing is a traditional West African method of arranging the hair into numerous small braids. It can take from two to six hours to arrange, depending on the complexity of the style. Beads were also used to accentuate the plaited strands (Sagay 1983). Used for hundreds of years in Africa, during the 1970s this African-inspired hairstyle penetrated the Western mass market when the movie actress Bo Derek wore her hair in cornrow braids in the movie *10* (Eubank and Tortora 1998). Decorating cornrow braids with beads is still an important part of West African hair traditions in the early 2000s.

Thread may also be used to wrap hair and is a more recent method of braiding used by men and women in the tropical areas of West Africa. The thread-wrapped hair causes the strands to raise from the head like spikes, creating a decorative hairstyle as well as keeping the head cool (Sagay 1983). The “trees” hairstyle is one style popular in West and Central Africa. The hair is parted into five sections, secured with rubber bands, and braided into cornrows. Each center section is wrapped with thread,

covering three-quarters of the entire hair's length. Different colored threads are sometimes used for an even more decorative effect (Thoman 1973). String has a similar decorative, fastening history. During the Ming Dynasty (approximately 1393 C.E.), Chinese women laced up their hair with gold and silver strings, decorated with emeralds and pearls (Xun and Chunming 1987).

Thread or yarns that are assembled into an open, gauzelike fabric creates a netting. Netting was used during the ancient Roman Empire and again during medieval times in Western Europe as a means to bind hair. In the middle of the nineteenth century, nets called snoods were a fashionable way for women to confine long hair at the base of the neck. They were revived once again during the 1940s. Older Chinese women also used netting during the Song Dynasty (960 C.E.–1279 C.E.) A black hair net covered their buns, and then jade ornaments were pinned in a random arrangement onto the net. It became known as *xiao yao jin* or “random kerchief” (Xun and Chunming 1987, p. 130).

Hair forks, hair spikes, and hair sticks have been used in diverse cultures, from Native Americans to Far Eastern nations such as China and Japan. Long hair was wrapped and knotted around the head, and then held in place by long hair spikes, sticks, or sometimes forks. The Native American hair forks or sticks were made from a variety of materials, but were often elaborately carved or polished (*Antiquity* 1997). Japanese women during the seventeenth century often fastened their buns with *kogai*, a straight bar used to pierce a topknot and hold it in place. During the twentieth century, mostly geisha and courtesans wore hair sticks, as most Japanese women had begun to adopt European costumes, hairstyles, and attitudes (Goodwin 1986).

Additional miscellaneous ornaments have been inserted into the hair over time and in numerous cultures, including (but not limited to): shells, coins, jewels, flowers, feathers, cow horns, bones, and sheepskin. In portions of North and West Africa, women would create intricate hairstyles that took three to four hours to decorate. If the woman's husband was away from home, hair ornaments were omitted as unnecessary. In South and East Africa, cow horns, bones, and sheepskin was used to adorn hair. Many of these totemic ornaments were worn by men rather than women (Sagay 1983).

During Egypt's New Kingdom, women typically plaited their hair rather than wearing wigs. These braids were then intertwined with colorful ribbons and flowers. The lotus flower was used frequently, as it symbolized abundance (Trasko 1994). In China during the Qin (221–207 B.C.E.) and Han (206 B.C.E.–7 C.E.) Dynasties, female dancers and aristocratic women alike adorned their buns with gold, pearls, and emeralds (Xun and Chunming 1987). In Western Europe during the medieval period, hairpieces and accessories were uncommon, due to strong Christian beliefs about covering women's hair for modesty and to indicate one's piety.

Adornments for the hair were discouraged, as they indicated an “unhealthy regard for personal vanity” (Trasko 1994, p. 27). In contrast, the Renaissance period focused on humanism rather than Christianity, prompting a renewed interest in hair ornaments. Women often adorned their hair to indicate their social status or for aesthetic purposes. Some of the more famous examples are the wigs worn by Queen Elizabeth in 1558. In portraits from this period, the queen visually portrays her power by wearing wigs adorned with large emeralds and rubies set in gold, as well as chains of large pearls. Women of lesser economic means wove flowers in their hair as a means of decorative ornamentation.

Perhaps the most fantastical hair arrangements for women in France, England, Spain, and Russia were found in the 1700s. During the rococo period, pink roses were desirable as hair accessories as they exemplified the graceful, feminine curves found in furniture and other decorative arts. Hair was accented with a *pompon*, or the placement of a few flowers or a feather amidst a hair arrangement (Trasko 1994). In Spain, women “fixed glow worms by threads to their hair, which had a luminous effect” (Trasko 1994, p. 66). These elaborate coiffures were status symbols in courts throughout Europe's fashionable cities, and were meant to be the “talk of the town” (Trasko 1994, p. 64). In the twenty-first century, most flower-adorned hairstyles for Westerners are worn only by brides on their wedding day. Real or artificial flowers may be used.

Native North American Indians often used feathers, as well as other parts of birds. In Mexico, colorfully feathered breasts of small birds were tied to the back of married Lacandon women's heads (Sayer 1985). The Minnesota Chippewa male Indians in the 1830s wore skins of birds as part of their “war bonnets.” The bird was associated with spiritual powers during wartime, and the men attached them to the “top of their heads, letting the beak bounce up and down on their foreheads. All kinds of accessories trim it so as to produce a general effect of hideousness likely to terrify the enemy” (Penny 1992, p. 215). In 1868, the Lakota recognized Sitting Bull as “head-chief” by presenting him with an eagle-feathered bonnet. Consisting of a beaded brow band, ermine pendants, and a double tail of black and white eagle tail feathers trailing down the back, each one of the feathers was a reward of valor, representing a brave deed performed by the Northern Teton Sioux warrior who had contributed it (Penny 1992, p. 215).

Lack of hair ornamentation seems to be the overall trend for the twentieth and twenty-first centuries. With the exception of the 1980s when hair accessories had a strong resurgence (Tortora and Eubank 1998), most modern styles seem to rely on haircuts and hair color to make visual statements rather than dressing coiffures with additional accessories. Perhaps this is best exemplified by the famous hairstylist Vidal Sassoon. In 1963, he told fashion press, “I'm going to cut hair like you cut mater-



ial. No fuss. No ornamentation. Just a neat, clean, swinging line" (Trasko 1994, p. 129).

See also **Costume Jewelry; Hairstyles; Jewelry.**

#### BIBLIOGRAPHY

- Anderson, Ruth M. *Hispanic Costume 1480–1530*. New York: The Hispanic Society of America, 1979.
- Antiquity*. Vol. 71. Gloucester, England: Antiquity Publications, 1997, pp. 308–320.
- Cox, J. S. *An Illustrated Dictionary of Hairdressing and Wigmaking*. London: B. T. Batsford Ltd., 1966.
- Goodwin, Shauna J. *The Shape of Chic: Fashion and Hairstyles in the Floating World*. New Haven, Conn.: Yale University Art Galleries, 1986.
- Penny, David W. *Art of the American Indian Frontier*. Seattle: University of Washington Press, 1992.
- Sagay, Esi. *African Hairstyles*. Portsmouth, N.H.: Heinemann Educational Books, 1983.
- Sayer, Chloe. *Costumes of Mexico*. Great Britain: Jolly and Barber, Ltd, 1985.
- Thoman, V. M. *Accent African: Traditional and Contemporary Gari Styles for the Black Woman*. New York: Col-Bob Associates, 1973.
- Tortora, Phyllis, and Keith Eubank. *Survey of Historic Costume* 3rd ed. New York: Fairchild Publishing, 1998.
- Trasko, Mary. *Daring Do's: A History of Extraordinary Hair*. Paris and New York: Flammarion, 1994.
- Xun, Zhou, and Gao Chunming. *5,000 Years of Chinese Costumes*. San Francisco: China Books and Periodicals, 1987.

*Julianne Trautmann*

**HAIRDRESSERS** Hairdressers seem to appear with civilization itself. Comparatively little is known about history's earliest coiffeurs, those who curled the beards of Sumerian princes and built the fabulous headdresses of Egyptian princesses, except that the Egyptian deities included a barber god. The market squares of ancient Greek cities included barbershops, where people could laze and gossip. Roman towns also contained hairdressing salons, visited mostly by the middle classes, while slaves dressed the heads of upper-class women. These practices survived in the Byzantine east, long after they had been destroyed in the Latin half of the empire.

The Viking hordes and Arthurian nobility of the Dark Ages doubtless continued to cut their hair and trim their beards, but hairdressers as such disappeared along with the cities where they had always practiced their trade. They return to recorded history with the revival of urban life and fashion in the Middle Ages. Medieval towns organized guilds of barber-surgeons who, in addition to shaving clients, lanced boils and pulled teeth. The hairdressing profession continued to develop during the Renaissance, particularly as women's headdresses became more popular and elaborate. More often than not, the ladies' hairdresser was principally a wig maker.

The modern era of splendid hairdos and celebrity coiffeurs, like "Champagne," who opened the first beauty salon in Paris, emerged with the development of court society in the seventeenth century. The courts of Charles II and Louis XIV were among the last places where men's coiffures were as important as women's, but as the elaborate headdresses of the era depended on the skills of wig makers—the French court contained more than forty of them in 1656—barbers became superfluous.

The eighteenth century belonged even more decidedly to the wig makers. While men's wigs generally took on more modest proportions, by the middle of the 1700s women's headdresses reached unprecedented dimensions and raised their architects to a new level of prominence. Léonard became the most famous of his peers, under the patronage of Marie-Antoinette. So much confidence did the queen place in her coiffeur that in 1791, as the royal family tried to flee Revolutionary France, she sent him ahead to Brussels with a collection of crown jewels—although she and the king were arrested before they could reach him there. The French Revolution hurt hairdressers by repressing extravagant coiffures and the taste for wigs and by hastening the destruction of the guilds that had protected barbers' monopoly on shaving and bleeding.

The fashions for clean-shaven faces for men and long, natural hair for women, made the century of industrialization and urbanization an unspectacular one for hairdressers. Barbers sunk to being among the poorest and worst paid of tradesmen. The appearance of King Gillette's remarkable safety razor in 1903 threatened them with the loss of much of their remaining business. As for ladies' hairdressers, the mass of working women in cities and on farms had neither need nor money for their services. Society dames might call on a hairdresser-*artiste* for a very special occasion, but most of the daily work of arranging hair fell to their ladies' maids.

It was only near the end of the century, with the appearance of the "marcel" wave, that the hairdressing profession began to take on its contemporary shape. The beautiful, long-lasting waves that Marcel and his imitators created attracted women to beauty salons in unparalleled numbers and gave hairdressers a huge new source of revenue. The success of "marcelling" also reflected important social changes, in particular women's growing independence and the expansion of the market for fashionable things among the popular classes, especially among young women. Ladies' hairdressers became pioneers on the frontier of mass-consumer society.

World War I further revolutionized the hairdressers' trade. First, by adding to women's economic and personal autonomy, it increased the market for hairdressers' services. Second, by pulling men out of the salons, it set in motion a process that feminized what had always been a predominantly male trade. The vogue for women's short hairstyles that swept through Western societies in the 1920s accelerated these developments. The majority

of ladies' hairdressers initially rejected what they considered a threat to their "art," but they soon came to embrace the radical new fashion for the revenue it brought. For short hair was not only cut, it was shampooed, "permed," and often colored, making salons more profitable even as they became more numerous. As the fashion for short hair spread beyond Europe and America, modern hairdressing salons began to open in Shanghai, Tokyo, and other major non-Western cities.

Although most shops remained very small, the number of large, chic salons multiplied. These usually belonged to the profession's luminaries and often were established in the more fashionable department stores. Antoine, the most luminous of all, expanded his operations to the United States through an agreement with Saks Fifth Avenue, which also sold a line of beauty products bearing his name.

In an era when new fashions and products gave ladies' hairdressers fresh business and artistic opportunities, barbers' fortunes continued to decline. Men's conservative haircuts proved barren ground for the sort of value-added services that fueled ladies' hairdressing, while, at least before the 1960s, the ethic of maleness sharply limited the market for cologne and cosmetics.

The consumer revolution that followed World War II carried more women than ever into the hairdressing salons. At the top of the profession, a host of new stars, led by Alexandre, the Duchess of Windsor's protégé, joined Antoine in the hairdressers' pantheon. Yet even as the trade became increasingly feminized, few women rose to the summit. The Carita sisters and Rose Evansky are rare exceptions.

In the 1950s, the modish styles of Vidal Sassoon and the "poodle cut" of the campy Raymond made London the second capital of hairdressing. Beginning with Jacques Dessange in 1976, the best-known coiffeurs began to attach their names not only to products but to salons, as well. In the 1980s and 1990s the practice spread rapidly, and in the early 2000s franchises bearing the names of Jean-Louis David, Jean-Claude Biguine, and others control a large portion of the hairdressing business all over the world.

Other fashion capitals turned out their own prodigies, who performed in international competitions and opened chic salons far from home in what by the end of the millennium had become an international society of hair fashion.

See also **Barbers; Hair Accessories; Hairstyles.**

#### BIBLIOGRAPHY

- Cooper, Wendy. *Hair: Sex, Society, Symbolism*. New York: Stein and Day, 1971.
- Corson, Richard. *Fashions in Hair: The First Five Thousand Years*. London: Peter Owen, 1965.
- Cox, Caroline. *Good Hair Days: A History of British Hairstyling*. London: Quartet Books, 1999.

Graves, Charles. *Devotion to Beauty: The Antoine Story*. London: Jarrold's, 1962.

Willet, Julie T. *Permanent Waves: The Making of the American Beauty Shop*. New York: New York University Press, 2000.

Steve Zdatny

**HAIRSTYLES** Standards of beauty have varied enormously according to time and place. Yet as long as people have ordered their social relations, hairdressing has had a role in the struggle for status and reproduction. "Humans," writes Robin Bryer, "are unique in two aspects of their behavior: wearing clothes and having their hair cut voluntarily" (p. 9). Hairdressing is part of the human condition.

One presumes that the first hairdos were long, scraggly, and filthy. Even given the general squalor atop primitive heads, however, it is likely that some hair was considered more attractive and admirable than others. What is certain is that wherever primitive society congealed into civilization, it produced a culture of hairdressing.

Archaeological evidence suggests that the early Egyptians wore their natural hair in tight braids. That changed with the discovery of the art of wig making. Hair was then cut short or shaved. Young boys retained their queues, but adults who could afford them wore wigs, especially for special occasions. Specialists made up elaborate head-dresses filled with jewels and expensive accessories and splashed with oils and perfumes. The Mesopotamian civilizations preferred heavy beards and long hair, often frizzed or waved. At Knossos, Cretan women wore elaborate coiffures, with golden hairpins, and lots of makeup. As always, different codes distinguished elites—kings, nobles, priests—from commoners.



In *Fashions in Hair: The First Five Thousand Years*, the author Richard Corson quotes a seventeenth-century source describing a teenage noblewoman attempting to turn her hair blonde. After exposing it to the hot sun for hours and anointing it with a coloring substance that seemed to produce the effect, she was afflicted with a near-daily nosebleed and

being desirous to stop the Blood by the pressing of her Nostrils, not farr from her right Eye toward her Temple, through a pore, as it were by a hole made with a needles point, the Blood burst out abundantly, and ... shee was diseased by the obstruction of her courses (p. 173).



**Advertisement for Solco Human Hair Products, 1924.** Since the dawn of civilization, hair styles have reflected every aspect of the human condition and often give important clues about the societies and cultures that spawned them. © CORBIS. REPRODUCED BY PERMISSION.

The ancient Greeks invented the beauty salon, where women had their cheeks blanched with white lead and their naturally blonde hair artistically dressed. Sometimes it was dyed red or blue. Spartan brides cropped their hair; Athenians wore veils over their dressed hair. They cut it as a sign of mourning. Beginning in the fifth century B.C.E., Greek men began to wear their hair short. It was Alexander the Great who insisted that his soldiers shave their beards in order to deprive their foes of a handle during combat.

Typically, the Romans at first copied the Greeks and then developed more elaborate hairstyles to match the imperial ethic. Men often wore their hair short, in what came to be called the “Titus,” after the Emperor. Attended to by the barbers who worked at the marketplaces and public baths, or by their slaves (who were shaved bald), both men and women curled their hair and dyed it red. They applied costly oils and pomatums or wore expensive wigs. The most extravagant powdered their hair with gold dust. In the East, Byzantine hairstyles

blended Greco-Roman culture with oriental. Men wore moderately short hair, mustaches, and beards. Feminine coiffures incorporated pearls and precious metals, which were also used for ecclesiastical costumes. Sometimes the fashion was for bare heads, sometimes for ribbons or ornamented turbans. Turbans became standard in Moorish culture—although the Islamic injunction against “graven images,” like that of the Jewish religion, means that documentation of Islamic hairstyles remains sparse before the Christian Middle Ages.

The paintings of the Pre-Raphaelites have provided a certain image of Arthurian damsels and knights. A small amount of evidence suggests that the period between the departure of the Romans and the arrival of the Normans in England favored flowing locks and facial hair for men. But, in fact, very little documentation about hairstyles during the Dark Ages survives.

The revival of European culture in the Middle Ages also brought back something like international fashion, of which coiffures were a part. Hairstyles differed between northern and southern Europe. And if the return of fashion meant anything, it was that coiffures popular at one moment became *démodées* in the next—although the fashionable “moment” in the Middle Ages could be rather long by later standards. The bobbed styles for men of the twelfth century were still around in the fifteenth, when smart Venetian gentlemen were also sporting yellow silk wigs. Depending on the time and place, women wore long braids or huge, horned headdresses. Or they packed their hair into a variety of bonnets and bags, often adorned with jewels and expensive knickknacks. The expanding middle class ordinarily adopted “quieter” versions of these noble styles. Poorer women wore their hair long and enclosed. Their men folk cut theirs short or shoulder length, while beards and mustaches came and went.

By the Renaissance, whatever the particular arrangement, hairstyles had become one of those idioms of international art that allowed fashion to circulate across the continent. Variety and inventiveness were the rules. Hair was frizzed, or not. Some women plucked or shaved their foreheads—thus becoming “highbrow,” in the manner of Elizabeth I, who was also reputed to own a hundred perukes. Blonde was the hair color of choice, and women bleached their hair by sitting in the sun and using saffron or medicated sulphur. Blonde wigs became the vogue in France and Italy, and nobles—Marguerite de Valois, most notably—would engage blonde maids in order to command their hair for wigs. Mary, Queen of Scots possessed many beautiful curled wigs and adorned her head with lace. Other ladies used pads and wire frames to give their coiffures volume.

Contemporary illustrations of the early sixteenth century depict Englishmen with long hair and clean chins. Beards were more popular on the Continent. By the end of the century, English courtiers had cut their hair and adopted stylish beards with precious names such as the “swallowtail” and the “spade.”



The portraits of the great Flemish painter Sir Anthony Van Dyke capture the Cavalier style that reached its height in the 1630s and 1640s, with men sporting long hair and neat, pointed beards under wide-brimmed hats. Hair became politicized briefly, during the English Civil War, when the more austere Protestant Roundheads battled the more elegantly coiffed forces of the English king, Charles I. The Pilgrims of the Colony of New Plymouth condemned long hair for men as prideful.

The Puritan position on hair must have softened, for later portraits of Cromwell depict him with longer hair, although not nearly as long as the styles coming out of the French court and brought back to England with the Restoration of Charles II in 1660. This was the great age of periwigs for men. Indeed, the French court imported so much blonde hair that Louis XIV's finance minister Colbert tried to ban wig making in France so as to stem the outflow of French gold.

The most popular women's styles of the period were the "hurluberlu"—unevenly cut and crimped, with two long curls over the shoulders—worn by Louis's favorite, Madame de Maintenon, and the "Fontange"—with its high curls secured by ribbon and bow—invented by the king's new mistress, the Duchess de Fontange. The fashions of Versailles traveled to all the other courts of Europe, and from there to the modish classes of every country.

In the eighteenth century, women's hair became the principal focus of art and conspicuous consumption. The massive headdresses of the middle decades serve as both the symbol of the Old Regime and the classic image of excess in fashion. It was in the 1770s that coiffures reached their most exaggerated form. Wendy Cooper describes "a certain Madame de Lauzun," whose "enormously high headdress," stuffed with the usual assortment of trash, was topped with "modeled ducks swimming in a stormy sea, scenes of hunting and shooting, a mill with a miller's wife flirting with a priest, and a miller leading an ass by its halter" (p. 95). Coiffures grew so immense that doorways had to be enlarged, and in two instances ladies were killed when their headdresses were set on fire by chandeliers. Men of weight and fashion in the Enlightenment wore modest, powdered wigs, although George III made enemies of English wig makers when he took to powdering his own natural hair.

The powdered look disappeared altogether in England when the Younger Pitt imposed a one-guinea tax on hair powder. Events in France had an even more revolutionary effect on hairstyles, as the fall of Louis XVI swept aside the fashion habits of the Old Regime. An era that admired the civic virtues of classical antiquity found men and women wearing their hair *à la Titus*. Those with a sharper sense of political irony adopted the mode *à la victime*, with their hair pulled up off the neck in imitation of those about to be guillotined. In the aftermath of the Terror, women wore their hair long and loose over di-



Billie Jones Kana describes her disappointing first trip to a beauty shop to have a "perm" in 1928:

As I recall, I couldn't have cared less about curls, but went along and was tortured beyond my wildest imagination ... first our hair was washed and cut, then we waited and waited. There were women everywhere in different stages of getting beautified. Everyone was waiting. My hair was wound up on spiral rods so tight that I thought I would never blink again [and] after the machine that looked like a milking machine was attached to the rods, I couldn't move. [Then] it began to steam and tears rolled down my cheeks.... Someone got a blower and cooled my head here and there, but my scalp was scalded (Willett, pp. 92–93).

aphanous dresses. No one in Revolutionary France wanted to look like an aristocrat.

In the nineteenth century, men's hairstyles tended to the short and simple. Common in one decade, facial hair vanished in the next, only to return thereafter. In mid-century Naples, the government so objected to mustaches that it instructed police to shave them off offenders. While men's hair became increasingly tame and standardized, women's coiffures retained their complexity, if not their old proportions. The early part of the century saw a vogue for concatenations of natural hair adorned with feathers, rich combs, and other items. Other moments featured puffs of curls or ringlets. Powder reappeared briefly on the hair of fashionable dames under the Second Empire. Chignons vanished in the 1870s; jeweled pins became popular in the 1880s. In general, the pace of fashion quickened, and intricate coiffures made ladies more dependent than ever on their hairdressers, even though the daily work of brushing and arranging a lady's hair fell to her lady's maid.

Wigs no longer played the dominant role in coiffure, as they had in the past. Still, the century admired long, luxurious hair, and since most women did not possess hair of sufficient quality or quantity, they made generous use of false hair. In fact, the taste for *postiches* (bits of false hair) drove the international market in hair to new heights. By the turn of the twentieth century, the United States was importing more than half a million tons of hair per year—a \$3 million business. Most of this stuff came from European peasant women in the poorer rural areas, who used their long tresses as a sort of cash crop.

The wheel of hair fashion took its next dramatic turn in the mid-1880s, when Marcel Grateau, a hitherto unknown hairdresser in Paris, perfected a technique for giving hair soft, beautiful, durable waves and thereby

launched the modern era of hairdressing. Replacing the nests of postiches and fancy bijoux, the “marcel” wave radically simplified ladies’ hairstyles. Many of the most celebrated coiffeurs hated the “marcel” for precisely this reason, but women loved it. An insatiable popular demand soon forced its opponents to capitulate, and the “marcel” wave became the basis of a fashionable coiffure for the next twenty-five years—although, to be sure, enterprising hairdressers found ways to dress “marceled” hair with the traditional assortment of feathers, flowers, and pricey doodads. The “négligé” styles of the Belle Époque, often colored with henna or dusted with white or gray powder, featured ribbons, enameled combs, and big chignons.

When the dean of French coiffeurs, Emile Long, complained about the cheap waves he saw on the *midinettes* (working girls) on the streets of Paris, he was pointing to the fact that the stunning success of “marceling” depended on a fundamental change in the social contours of fashion. It coincided with the early stages of a big expansion in the market for fashionable things in Western society.

In effect, three developments combined to create the modern beauty salon and the culture associated with it. First, rising wages gave women more disposable income, while greater autonomy freed them to spend it as they pleased. Second, a loosening of social constraints made it more acceptable for women to move in public spaces, that is, to take their toilettes out of the boudoir and into the hairdressing salon. Third, a critical series of technological developments expanded the services available in the salon.

New sensibilities about hygiene, combined with water heaters and hair dryers, encouraged women to have their hair shampooed. Non-toxic dyes helped dissolve old taboos about hair coloring. Most critically, the invention of the permanent-wave machine enabled women to alter their hair dramatically, while it brought hairdressers a huge new source of revenue. For a few hours hooked up to this contraption, a woman would pay anywhere from ten to fifty times the cost of an ordinary haircut. These new consumer habits were nourished by the growing number of magazines aimed at middle- and working-class women, and especially by the movie stars who were coming to dominate popular ideas of beauty and fashion.

All of this paved the way for the “bob,” which proved to be a seminal moment both for coiffure and for Western society more generally. From the lacquered “garçonne” of Josephine Baker to the more fluid “Eton crop,” the bob had many incarnations. Some of them had appeared on some stylish young heads before World War I, especially in the United States. But the vogue took off only in the 1920s, when it became part of the aesthetic turnabout associated with “flappers.” As the “androgynous” clothes of Coco Chanel surpassed the curvaceous styles of the great Edwardian couturiers, so the bob became the badge of the so-called Modern Woman.

No other hairstyle in history provoked so much comment and controversy. Cultural conservatives hated it for its challenge to inherited gender verities. Stories abound of outraged men locking up, even murdering, their newly shorn wives and daughters. On the other side, women endorsed it by the millions. Observers generally saw the short hairstyles and women’s spontaneous taste for them as evidence of a significant “emancipation” of women. It is true that the bob provided some relief from the arduous regimes of Edwardian coiffures. At the same time—permed, dyed, in need of frequent retouching, and often requiring a postiche for evening wear—it was hardly carefree or cheap.

At the end of the day, however, the bob was more fashion than political statement, and by the close of the Roaring Twenties, women had begun to tire of it. The hairstyles of the 1930s, created by such international stars as Antoine and Guillaume, were longer and more “feminine,” although there was no return to the massive, superfluous hairdos of the pre-bob era. The Platinum Blonde, curvy and sexy, defined the new “New Woman” of the depression decade. Men in the period between the wars continued to favor short, neat haircuts, accompanied sometimes by a thin moustache (never by a beard) in the manner of Rudolph Valentino or Clark Gable.

The war years, rich in misery, were poor in new hair fashions. *Haute coiffure* survived mostly in Hollywood, where, for example, Veronica Lake became famous for the silky blonde hair that fell across half her face in the “bad-girl” style that alarmed some moralists. More commonly, millions of women involved in the war effort tucked their short, simple hairdos under military caps or hard hats. If the war brought the world one distinctive hairstyle, however, it would have to be the shaved heads belonging to camp survivors and “horizontal” collaborators.

The consumer revolution, born out of the ashes of war, once again transformed hairdressing. Stylistically, the postwar years promoted the so-called petite tête, the compact hairdos that fit so well with Christian Dior’s fashion revolution, the New Look. Long styles made a partial comeback in the 1950s, led by the “artichoke” cut that Jacques Dessange created for the nubile Brigitte Bardot. The clear trend, however, was toward more compact coiffures. In the United States, ponytails became the classic expression of 1950s adolescence.

In the end, the 1950s may be less important for stylistic innovation than for the changes in the structures of consumption that occurred. While disposable incomes rose steadily, a growing mass media of movies, television, women’s magazines, and broadcast images of beauty and stimulated the demand for fashionable commodities. More and more women indulged themselves in a weekly visit to the beauty parlor. In the United States, this became one of the defining rituals of middle-class femininity and an important communal event. At the same time, new hair care products—“cold” perms, do-it-yourself hair

coloring, and setting—allowed women to exercise much of their expanding beauty regimen at home.

Men continued to provide a much poorer field for art and profit. Their haircuts became, if anything, plainer in the 1950s. Yet change was in the air. Rebellious teenagers began to turn away from crew cuts and flattops by wearing the “duck ass” cut associated with the likes of James Dean, Elvis Presley, and Johnny Halliday. In France, George Hardy achieved a small breakthrough in 1956 when he introduced the razor cut. Beards and mustaches turned up on the chins and lips of “beatniks” and other nonconformist types.

“Anti-fashion” hair spread over the next few decades, following the prominence of rock stars and hippies. Blacks in America and Europe put aside the hair-relaxing agents they associated with self-loathing and began to sport voluminous Afros. In the 1970s, “Mohicans,” dreadlocks, and the sinister skinhead became the protest hairstyles of choice. Throughout, sales of personal grooming products for men increased, and the men who visited the new “unisex” hair salons paid more than the proverbial “two bits.” But hairdressing remained an overwhelmingly female preoccupation.

The “beehive,” made possible by the invention of lacquered hairspray and the copious use of false hair, carried the 1950s ideal of femininity into the sixties. However, that raucous decade really belonged to the geometrical cuts that Vidal Sassoon created to fit the latest styles of Mary Quant, creator of the miniskirt. *Haute coiffure* survived, as the profession’s contemporary stars coiffed movie stars, society dames, and runway models. But the rule for the last quarter of the twentieth century was variety and innovation. Hairstyles were long or short, flowing or spiked, natural or tinted, straight or permed.

The diversity of coiffures also reflected a critical change in the trajectory of fashion. In the days of Marie Antoinette or Marcel, a small, privileged elite made the laws that ruled taste. In the twentieth century, the masses gained a larger and larger say in the success of this vogue or that. By the end, masses of women were not merely endorsing (or not) the choices made by a select group of the fashionable. “The street” produced its own styles, which then permeated the formal structures of fashion.

The ceaseless evolution of hairstyles has produced a lot of speculation, both casual and academic, on their etiology and meaning. Numerous speculations have linked coiffures, not coincidentally but organically, to their historical moment. The many observers who attributed the popularity of the bob to women’s emancipation provide the most pointed example of this. Others have gone further and tried to find the deeper meaning of forms. The French critic Roland Barthes offered an entire science, semiotics, dedicated to deconstructing those forms.

Hairstyles can unquestionably supply important clues about the societies that produce them. Once again, the bob is the perfect illustration. Permed, tinted, cre-

ated in commercial establishments with electricity and hot running water, and consumed by millions of women spending considerable sums of money, it has a lot to say about Western civilization in the 1920s. Sometimes the meaning of coiffures is not hidden at all, but openly proclaimed, as it might be in a punk band, a neo-Nazi rally, a hippies’ commune, or a lesbian rights parade.

Yet, in many ways, those who assert the free-flowing nature of fashionable “signifiers” have the stronger argument. After all, “liberated” women of the 1960s often sported long, straight hair, while the sainted defender of a medieval French king, Joan of Arc, wore a bob. It seems fair to say that in a historical world where Charles II and Cher look alike from behind, the forms of fashion obey an elusive logic of their own.

See also **Afro Hairstyle; Barbers; Hair Accessories; Hairdressers.**

#### BIBLIOGRAPHY

- Asser, Joyce. *Historic Hairdressing*. Bath: Pittman Publishing, 1966.
- Bryer, Robin. *The History of Hair: Fashion and Fantasy Down the Ages*. London: Philip Wilson, 2000.
- Cooper, Wendy. *Hair: Sex, Society, Symbolism*. New York: Stein and Day, 1971.
- Corson, Richard. *Fashions in Hair: The First Five Thousand Years*. London: Peter Owen, 1965.
- Cox, Caroline. *Good Hair Days: A History of British Hairstyling*. London: Quartet Books, 1999.
- Keyes, Jean. *A History of Women’s Hairstyles, 1500–1965*. London: Methuen, 1967.
- Louis, M. *Six Thousand Years of Hair Styling*. New York: M. Louis, 1939.
- McKracken, Grant. *Big Hair: A Journey into the Transformation of the Self*. Woodstock, N.Y.: The Overlook Press, 1995.
- Rambaud, Rene. *Les fugitives. Precis anecdotique et historique des coiffures feminines a travers les ages, des Egyptiens a 1945*. Paris: Rene Rambaud, 1947.
- Reynolds, Reginald. *Beards: Their Social Standing, Religious Involvements, Decorative Possibilities and Value in Offense and Defense through the Ages*. New York: Doubleday and Co., 1949.
- Severn, Bill. *The Long and the Short of It: Five Thousand Years of Fun and Fury over Hair*. New York: David McKay and Co., 1971.
- Trasko, Mary. *Daring Do’s: A History of Extraordinary Hair*. New York: Flammarion, 1994.
- Willet, Julie T. *Permanent Waves: The Making of the American Beauty Shop*. New York: New York University Press, 2000.

Steve Zdatny

**HALLOWEEN COSTUME** The wearing of Halloween costumes in America reaches back into the country’s cultural history. This shared American folk ritual is a window on the diverse ethnic and religious heritage of the people who settled the United States.





**Children trick-or-treat on Halloween.** The concept of the Halloween costume traces its roots back to the ancient Celtic festival of Samhain, during which revelers wore disguises to foil restless spirits. © ARIEL SKELLEY/CORBIS. REPRODUCED BY PERMISSION.

Halloween itself has deep folk roots. It originates with the Celtic Day of the Dead autumn festival of Samhain, celebrated by Celts throughout Europe in ancient times and celebrated still in northern France, Ireland, Scotland, Wales, and other regions where the Celtic heritage is preserved. The Celts used a lunar calendar and divided the year into two seasons. Winter, the season of the dying, began on Samhain (which roughly translates as “summer’s end”), which fell on the full moon closest to 1 November after the harvest was complete.

Samhain was the first day of the Celtic New Year, and it was believed that the souls of those who had died were extremely restless this night, which marked the porous border between the living and the dead, the old and new year, and summer and winter. At Samhain, people disguised themselves in feathers and furs so as not to be recognized by the spirits wandering the earth that night. When the Celts converted to Christianity, Samhain was amalgamated with All Hallows’ Eve, the evening before All Saints’ Day, the night that is now

called Halloween. (All Saints’ Day is followed by All Souls’ Day, 2 November.)

Originally a feast marking the departure of souls from the material world to the spiritual world of the dead, All Hallows’ Eve was widely celebrated throughout the European world, and particularly in countries with a Catholic tradition. In America, the seeds of the distinctively American festival of Halloween date back to the 1840s. The arrival in the country of large numbers of Irish immigrants, following the disastrous potato famine in Ireland, helped establish the feast in America. Their celebrations of All Saints’ and All Souls’ Days still preserved many of the ancient rites of Samhain. For example, the carving of pumpkins comes from the Irish legend of Jack, a man so evil that when he died he was rejected by both heaven and hell and was condemned to roam the countryside with nothing but a glowing turnip for a head.

Halloween in America became a folk holiday sanctioned neither by the church nor the state. Ancient roots in European culture, the arrival of many different groups

of immigrants, and the constantly evolving nature of U.S. culture have continued to shape this distinctly American celebration. Contemporary celebrations of Halloween reflect many different cultural traditions, such as England's Guy Fawkes Day and Mexico's *El día de los muertos*. During colonial times Americans gathered for harvest festivals that (like the Celtic Samhain) acknowledged the end of the bountiful summer; these festivals also gave rise to the distinctive American festival and rituals of Thanksgiving. At these harvest festivals, ghost stories were often told, a reminder of the bridge between the living and the dead. Divination games, often with unremembered but very ancient roots, were played; for example young women bobbed for apples to determine whom they would marry.

During Victorian times, Halloween began to become a quaint holiday with rituals that emphasized children's participation; the festival's folk and religious roots were downplayed. By the early twentieth century, Halloween had become a celebration for children. Community organizations arranged parades and haunted houses. During the 1940s trick or treat was added to the traditions; this custom of begging in costume had very old roots in European culture, and was explicitly transgressive, forgiving behavior that would otherwise be frowned upon. Children would sing or perform mimes in exchange for a treat; they also implicitly threatened to play tricks on householders if a treat was not forthcoming. Homemade masquerade costumes appeared as early as the nineteenth century. Women's magazines printed instructions for making costumes at home. Later these homemade costumes increasingly gave way to commercially produced costumes, a trend that began at the time of the industrial revolution. During the second half of the nineteenth century, advances in technology made commercially produced costumes cheaper, better made, and more varied. The earliest costume themes, all of which continue to the early 2000s, were ghosts, skeletons, devils, and witches. Otherworldly creatures such as Frankenstein, the Mummy, and Dracula are drawn from popular culture.

The Dennison Manufacturing Company in Massachusetts began making paper costumes in 1910. Collegeville, located in Pennsylvania, began as a company that produced flags and later used the scraps to create costumes around 1910 and continued to make early clown and jester costumes. Its namesake founded the Ben Cooper Company in 1927. Based in Brooklyn, New York, Cooper created theatrical sets and costumes for the Cotton Club and the Ziegfeld Follies, and expanded into Halloween costumes in 1937. The company later joined with A. S. Fishbach, a New York City-based costume company that held the license to Disney characters, such as Donald Duck, Mickey and Minnie Mouse, and the Big Bad Wolf, and packaged them under the name Spotlight. Cooper sold his company in the 1980s to Rubies, also in New York, which has become one of the largest producers of Halloween and Purim costumes in the United States.

Many of the masks for the early costumes were produced by U.S. Mask Company in Woodhaven, New York. Their earliest gauze masks, made of buckram, were sprayed with starch and steamed over a mold. Themes included witches, clowns, and animals. In the 1950s vacuum-formed latex masks appeared. Figures from popular culture, such as the Beatles and John and Jacqueline Kennedy, joined TV and film personalities such as Laurel and Hardy, and dolls and action figures such as Barbie and G.I. Joe, in being molded in latex. Other major costume companies in America included Halco, in Pennsylvania; Bland Char-nas Company on Long Island, New York; and E. Simons and Sons, in New Orleans, Louisiana.

The costumes produced in America are testaments to the creative powers of ordinary people. The makers demonstrate a technical and aesthetic skill that reflects the handmade techniques used in home production and in factories before mass-machine production took over. These costumes express the personal, social, and cultural identity of the people, and transcend the barriers of class and ethnicity. Halloween has become a uniquely American ritual, not only for children but for adults as well, and it grows in popularity from year to year. (Halloween has also become an important holiday for the gay community, with large, elaborate costume parades in San Francisco, New York's Greenwich Village, and other gay centers.) Halloween allows individuals to experience and explore the shared ethnic, cultural, and folk celebrations that have engaged diverse peoples since ancient times.

The Jewish festival of Purim, which commemorates the Biblical story of Esther, is celebrated on the fourteenth and fifteenth days of the twelfth month of the Jewish calendar, usually in March. In America, Purim celebrations have taken on many of the trappings of Halloween, with costumed children wielding noisemakers and giving gifts of food or donating to charity.

See also **Occult Dress**.

#### BIBLIOGRAPHY

- Galembo, Phyllis. *Dressed for Thrills: 100 Years of Halloween Costume and Masquerade*. New York: Harry N. Abrams, 2002.
- Rogers, Nicholas. *Halloween: From Pagan Ritual to Party Night*. New York: Oxford University Press, 2002.
- Santino, Jack. *Halloween and Other Festivals of Death and Life*. Memphis: University of Tennessee Press, 1994.

Phyllis Galembo

**HALSTON** The designer Roy Halston Frowick (1932–1990) was born in Des Moines, Iowa, and began his career as a milliner. He subsequently rose to become one of the most important American designers of the 1970s, whose influence was still being felt into the twenty-first century.



### HALSTON'S CLIENTELE

Halston's most famous saying was "You're only as good as the people you dress." If that is true, he was better than good. He was good enough, in fact, to win five coveted Coty Fashion Critics Awards, the Oscars of the fashion industry. Halston's clientele list reads like a who's who of celebrities and socialites: Lauren Bacall, Marisa Berenson, Candice Bergen, Princess Grace of Monaco, Katherine Graham, Margaux Hemingway, Bianca Jagger, Liza Minnelli, Jackie Kennedy Onassis, Elsa Peretti, Barbara Cushing "Babe" Paley, Lee Radziwill, Elizabeth Taylor, and Barbara Walters.

### Biography

While studying fashion illustration at the Art Institute of Chicago in 1952, Halston began designing hats in his spare time. Eventually, he started to sell his designs at André Basil's hair salon at the Ambassador Hotel. Halston moved to New York City in 1958 to design hats for the legendary milliner Lilly Daché and then began working in the custom millinery salon of the prestigious retailer Bergdorf Goodman in 1959. While there, he designed the famous pillbox hat worn by the First Lady Jacqueline Kennedy for the 1961 presidential inauguration of her husband, John F. Kennedy.

Moving beyond hats, Halston went on to design his first clothing collection for Bergdorf Goodman in June 1966. Two years later he left the retailer to form his own company, Halston Ltd. In December of 1968 Halston showed his first namesake collection in his new Angelo Donghia-designed showroom at 33 East Sixty-Eighth Street in New York City. As his business grew, Halston took over the entire building, creating a retail boutique in 1972 that took up three floors of the building, with each floor selling a different collection (and at a different price point). Later that year a ready-to-wear company, Halston Originals, was formed with two partners and headquartered on New York's Seventh Avenue.

In a first-of-its-kind deal for a fashion designer, Halston and his partners sold both the Halston businesses and the Halston trademark to Norton Simon Industries (NSI), a large multibrand corporation, in 1973. Halston's success soared during the mid-1970s, and so did his fame. An article in *Esquire* magazine asked the question: "Will Halston take over the world?" (p. 69).

As the success continued, NSI started signing a multitude of licensees—thirty existed at one point. In 1978 the company moved its design studio to a spacious venue on the twenty-first floor of the Olympic Tower at Fifty-

first Street and Fifth Avenue. With the bigger space once again came an increased workload. Eventually, Halston was designing four ready-to-wear, four sportswear, and two made-to-order collections per year. All this was in addition to furs, shoes, swimwear, robes, intimate apparel, men's wear, luggage, and uniforms for both Avis Rent A Car System and Braniff Airline employees. Halston also continued to design costumes for his celebrity friends, including the performer Liza Minnelli, and for Martha Graham's dance company.

By the early 1980s, however, Halston's influence was waning, and his social life began to garner more attention than his fashions. The beginning of the end, according to many, came when, in 1982, Halston signed a multimillion dollar deal with the J. C. Penney discount chain to create products under the Halston label. Many prestigious retailers voiced concern about the deal, and Bergdorf Goodman dropped the designer's ready-to-wear line from their store.

Before signing the deal with Penney's, things had started to unravel for the designer. Many cite the pressure of his workload and his inability to delegate responsibility as major faults. Others noted that as he spent more time socializing, allegedly using drugs, and as his increasingly difficult temperament became apparent, his business started to fail. In 1984, with tension mounting between the designer and NSI, Halston took a two-week vacation and never returned to Halston Enterprises. Until 1988 he kept trying to buy back a part of the company that bore his name from the various owners of the trademark, but he was unsuccessful. While negotiating one such buyback with Revlon, the owners of the trademark, in 1988, Halston tested positive for HIV. He died of complications from AIDS on 26 March 1990.

### Mr. Clean

Halston was known for his minimalistic approach to fashion, and his signature looks were spare, fluid, and often deceptively simple. He married the ease and comfort of sportswear with ready-to-wear and then raised the bar with luxurious fabrics and his distinct eye for cut and proportion. Halston has been credited with creating a unique new look, an original American way of dressing. His clothes were a representation of his own pared-down lifestyle. Many say that his life and his work were one and the same. In simplifying fashion for modern lifestyles without sacrificing glamour and luxury, he influenced many other designers. "Halston was one of the most influential designers of our time," said Donna Karan, quoted in Gross and Rottman (p. 225). "I say that on a personal level, because when I was young, he was the designer I aspired to be like. He understood luxury, glamour, simplicity, fit and the importance of uniform. To me, he represented all that was modern and pure. What more could a designer hope to be?" Narciso Rodriguez, also a fan, said, "Halston changed the face of fashion and the way women dressed with a clean and pure look. Within its purity there was extreme femininity and sexiness. His slink



dress as well as his doublefaced coats both maintained his clean, sensual line with brevity of construction. He is one of my heroes!” (Gross and Rottman, p. 225.)

In her book *The Fashion Makers*, Bernadine Morris wrote, “A nod from Halston and a fashion is flashed around the world” (p. 90). After Halston fell in love with Ultrasuede in 1971, he went on to use the fabric in everything from suits and coats to his famous shirtdress. As a result, Ultrasuede became as famous as Halston himself.

When he tied a sweater around his models’ shoulders, the look was adopted by fashionable women everywhere. Other designs also became Halston trademarks: the strapless dress, dresses made of draped rayon matte jersey, cashmere knits, caftans, one-shoulder and halter dresses, and asymmetrical necklines. He was well known for his love of the bias cut and his single-seamed spiral and wrapped dresses. In 1976 the designer created his first perfume, the enormously successful Halston. The Elsa Peretti–designed tear-shaped bottle was so recognizable that Halston insisted that it not be stamped with his name. The only branding was a small paper band with the name “Halston” that was wrapped around the neck. It broke off when the bottle was opened.

See also **Dance and Fashion; Flocking; Hats, Women’s; Ready-to-Wear; Retailing; Sportswear.**

#### BIBLIOGRAPHY

- Berkin, Lisa. “The Prisoner of 7th Avenue.” *New York Times Magazine*, 15 March 1987.
- Bowles, Jerry. “Will Halston Take Over the World?” *Esquire*, August 1975, p. 69.
- Gross, Elaine, and Fred Rottman. *Halston: An American Original*. New York: HarperCollins Publishers, Inc., 1999.
- Herald, Jacqueline. *Fashions of a Decade: The 1970’s*. New York: Facts on File, 1990.
- Milbank, Caroline Rennolds. *Couture: The Great Designers*. New York: Stewart, Tabori and Chang, 1985.
- Morris, Bernadine. *The Fashion Makers*. New York: Random House, 1978.

Fred Rottman

**HANDBAGS AND PURSES** The handbag is much more than a functional alternative to the pocket. In the course of time it has become a design object in its own right, a signature mascot for the major French couture houses (surpassing the role of perfume as a brand identity) and a powerful symbol of growing female independence. Until the late 1700s, both men and women carried bags. When the *directoire* fashions of 1800 streamlined the female silhouette, the need for an exterior pocket created a permanent role for the woman’s handbag.

In antiquity, bags were used to carry weapons, flint, tools, food, and eventually money. Egyptian burial chambers of the Old Kingdom (2686–2160 B.C.E.) contain



**Actress Charlize Theron holds a Fendi handbag, February 9, 2004.** Major fashion accessories in the late twentieth and early twenty-first centuries, handbags were originally conceived for very practical concerns, such as storing flint and money. © FRANK TRAPPER/CORBIS. REPRODUCED BY PERMISSION.

double-handled leather bags designed to be suspended from sticks, as well as bags made from linen and papyrus. The ancient Greeks used leather bags called *byrsa* as coin pouches; this is the source of the English word “purse.” The rise of coin currency gave birth to the drawstring purse, an item always worn close to the body and most often suspended from a belt or secreted within folds of clothing. Judas sealed the fate of Jesus with a purse full of silver coins. Roman women used net purses; the Latin term *reticulum* (meaning net) was revived in the 1790s. One of the earliest ornamented leather purses to be recovered from Anglo-Saxon Britain came from the burial mounds of Sutton Hoo in Suffolk, assumed to be the burial site of King Roewald, who died in 625 C.E. The leather body of the bag had deteriorated but its gilt ornaments remained intact. The purse had a lavish lid decorated with gold, silver, garnets, and millefiore glass. Containing forty gold coins and hung from hinged straps on a waist belt fastened by a large gold buckle, the purse was part of a suite of regal accoutrements.

The heraldic symbol for Saint Matthew, the tax-gatherer, was a rucked moneybag and this symbol was

emblazoned upon the crests of treasurers and titled families with large landholdings. Ritual contents also made bags precious and many trends for the ornamentation of secular fashion began with bags made for the church. A Byzantine relic pouch of the ninth century stored at St. Michaels in Beromunster, Switzerland, was lined in red silk and worked with intricately embroidered lions on a blue silk ground. By the thirteenth century, the popular term for a bag in Western Europe was an almoner. This term referred to an alms bag, that is, a purse to hold coins to be given as charity. Almoners lent a rather showy side to Christian charity; the richer the purse the more generous the social image of the Lady who carried it. Such pomp gave rise to thievery, the term “cut-purse” came into use in 1362.

The purse was also an important offering in the ritual of courtly love. The most amusing and sophisticated bags of the fourteenth and fifteenth centuries were made as gifts to lovers, decorated with allegorical scenes and mottoes alluding to the trials of romance. One bag dating from the mid-fourteenth century (housed in the Musée Historique des Tissus, Lyon) depicts a lady posing as a falconer and her lover as the falcon, a witty reversal of the roles of hunter and prey. On another fourteenth-century French bag (from the Troyes Cathedral Treasury) two female rivals are depicted sawing a human heart in half. The tradition of the wedding or betrothal bag originated in the medieval custom of a groom presenting his bride with a sack of coins. In art, the drawstring purse came to connote female sexuality. Albrecht Dürer, Lucas Cranach, and others depicted many a lascivious older man reaching for the drawstring pouch of a younger woman. Female genitalia were referred to in Shakespearean slang as a purse. The eroticism of the bag was heightened by the way almoners, purses, and “harmondeys” were worn, suspended from a girdle that tightly straddled the belly or swayed suggestively about the hips.

In the fifteenth century, large and elaborate bags with cast-metal frames became more common and were carried by men of the ruling class. In the late sixteenth and early seventeenth centuries, the size and shape of bags diversified, and the tiniest bags denoted the greatest status. Small, square embroidered “swete” bags containing perfumed pomanders, rose petals, rare spices, and oils were worn to scent skirts and cuffs and used as containers for personal gifts. Over time, swete bags and coin purses assumed increasingly ornamental shapes. One small purse from the Museum of London is a life-sized crocheted frog that fits snugly into the palm of the hand. Made of cream silk with silver mesh, the mouth of the frog forms the opening of the bag just large enough for a tiny coin. The Elizabethans had a taste for visual conceits and allegory. A bag in the shape of an acorn symbolized thrift, but was likely to be worn in the manner of a precious jewel, wound about the wrist or bouncing against full skirts. Satchels and sacks worn across the body were for peasants and pilgrims; often made from recy-

clad socks or scraps of cloth; these bags are now known mainly from paintings and etchings as few actual examples survived their heavy daily use.

The rise of the evening bag can be dated from the seventeenth century, when men and women used gaming bags to carry their chips and coins. Designed to sit flat upon a table, these bags reflected a new sophistication in form. With a shallow tightly ruched drawstring body attached to a circular base stiffened with cord or leather, the bases of these bags were often decorated with the initials or coat of arms of their owner to avoid any confusion over the night’s winnings. The square shape that had dominated bag design for two centuries or more was now sprouting into three dimensions. Bags were made of interlocking panels in the shape of crescents, shields, and pentagons and told little stories (of heroic colonial enterprise or secret love) on each individually embroidered panel. The idea of the bag as a narrative in itself or a formal social badge for its owner expanded in the eighteenth century when leather folding wallets featured one’s name and title boldly embossed on the front, usually in gold letters. By the middle of the seventeenth century, bags and purses for women became smaller and tended to be obscured within the folds of large skirts made even more voluminous by hoops and farthingales. Increasingly, the bag had to compete with its much more practical rival: the pocket.

At the beginning of the eighteenth century, the role of the bag for men and women began to divide. Men might resort to slipping a small, netted purse into their sleeve or slung over the belt buckle, but they no longer dangled leather or cloth bags from a long drawstring at the waist. The notion of an elaborate bag with a drawstring or handle became more and more feminized as the century progressed. As masculine fashion became even more streamlined with tight breeches and cutaway coats, men were forced to compress their needs into custom-made wallets that contained everything from a compass to nail scissors and a snuff bottle. Eighteenth-century women carried small purses on the wrist, toted large silk and cotton workbags for knotting and personal effects on the arm and had the additional storage space of large pear-shaped pockets worn laced around the hips beneath their petticoats.

All of this extra room gave birth to a culture of the handbag long before the handbag proper came into existence. Women grew accustomed to carrying their workbags about socially, slipping extra items in for evening such as fans, smelling salts, cosmetics, and opera glasses. In their dimity pockets they carried small leather-bound pocketbooks whose printed pages included calendars, recipes, songs, and Saint days as well as engravings of the latest dress and hat models. A precursor to the modern fashion magazine, the pocketbook added depth to the idea that a woman carried the world in her pocket.

Despite the capacious generosity of pockets and knotting bags, small purses for women remained popu-

lar, and their decorations reached a peak of worldly topicality. A woman could advertise her love of science or a political allegiance with the elegant flick of a wrist. The fine sable beaded bags produced in Paris from the 1770s on, wove up to 1,000 tiny glass beads onto each square inch of the bag's surface, lending a remarkable clarity to color, lettering, figures, and detail. One such beaded bag from 1784 was decorated with hot-air balloons and the face of Jean-François Pilâtre de Rozier, the French balloonist who made his maiden voyage the year before. Printed images on silk also offered swift production of commemorative and novelty bags.

By 1799, hand-netted bags were referred to in England as "indispensables" and in France as reticules, after the netted bag (*reticulum*) carried by Roman ladies. Handbags were in existence even before chemise-style dresses became fashionable, but bags became permanently established as a feminine accessory once the long, sheer and close-fitting dresses of the *directoire* eliminated the space for pockets altogether. As with all new fashions there was a period of adjustment, and fashionable women of Paris and London were reported to be secreting small coin purses into their décolletage or slipping important letters into the leaves of their fans. The need for an alternative to the pocket gave birth to early bags that looked very similar to the pear-shaped pockets of the late 1700s, simply grafted onto a silken drawstring. There was some social outcry at the notion of wearing such an intimate article in public but demand soon replaced dissent. The Parisian *Journal des modes* quipped, "One may leave one's husband but never one's bag."

The prevailing shape of the first decade of the nineteenth century was the drawstring reticule but frame bags began to come into use. Bag size is always contingent on the shape, cut, and proportion of clothes; as skirts grow larger bags tend to shrink. In the mid-nineteenth century, alternative containers such as muffs, link metal chain purses, knitted miser bags, and chatelaines (a range of miniature domestic trinkets worn hung from a belt) competed with the hand-held bag for carrying coins and small personal articles. Unlike the deliciously worldly style of the eighteenth century, the Victorian era idealized domesticity and sentimentality. Bags reflected these themes with hand-beaded patterns of home and hearth (bought commercially or made at home), hand-painted scenes of mourning on black satin, and arrangements of flowers encoded with private messages for loved ones. Bags made at home advertised the skill of their maker and were given to eccentric almost esoteric detail, commercially made leather frame bags for shopping and train travel were far plainer, designed for security, respectability, and privacy. These two trends were to echo the split identity in handbags into the next century and beyond. The idea became established that a woman could own several very different bags for different occasions and different personae.

By the 1880s the handbag had become a fashion fixture. Based on the design of much larger luggage and the

traveling carpetbag (first executed in tapestry fabric by Pierre Godillot in France in 1826), necessity had bred a very plain, useful bag that became the blueprint for all to come. Most of the classic bags known today were invented and developed by the great luggage and saddlery houses of Paris in the late nineteenth century. Louis Vuitton made traveling trunks for Napoleon III. In 1896 he had logos based on his initials hand-painted onto his trunks and hand luggage to defy counterfeiters. His steamer trunk of 1901, designed to hang on the back of a cabin door with a long canvas body and short, strong leather straps, is the precursor to the tote bag. Emile Maurice Hermès had the vision to transform feed and saddle bags into elegant travel accessories. The genesis of the Kelly and later the Birkin bags were in tall leather satchels designed to hold saddles: the Haut à Courroies. Hermès was also the first to apply the Canadian army cargo zipper as a modern fastening, bringing it back to Paris in 1923 to create the Bolide, a driving bag for his wife. Travel in the early years of the century was not about expedience but studied luxury, and the grand French houses created classics out of an ingenuity for stylish living. The Noe bag was designed by Vuitton in 1932 as a satchel to carry exactly five bottles of champagne. This design formed the basis of all shoulder strap bucket bags to follow. The Plume bag designed by Hermès in 1933 was based on a square horse blanket bag and updated with thin central straps and a zip that encircled the body of the bag. An heir to the Hermès Bolide of 1923, this simple square bag was the model for the gym bag including the Adidas tennis bag of the 1980s and the Prada bowling bag of the 1990s. The tote, the bucket, and the box are the geometrical foundations of twentieth-century design. Bags have gone to every extreme since but their origins always return to these three templates.

From 1900 to 1914 handbags swung like a pendulum between exotic fantasy and pragmatic reality. In one last nostalgic bid against the fully mechanized age, there was a brief vogue for tiny silver mesh bags, large velvet chatelaine bags with hand-carved silver frames, and elaborately beaded German and Italian bags depicting fairy-tale castles, Renaissance landscapes, and rococo ladies in hoop skirts. The influences of orientalism and art nouveau spread the desire for bags cut from antique textiles, ecclesiastic velvets, tapestry, and handmade lace. Leather shoulder bags were pioneered by the suffragette movement, and when war came in 1914 this style gained serious ground. During the 1920s there was a trend for bags that were androgynous, sleek, and held close to the body. The Exposition of Decorative Arts held in Paris in 1925 influenced every aspect of handbag design from the geometric abstraction of their hardware and decoration to the streamlining of their form and function. Lancel, the French luxury leather goods firm, presented a sleek purse in 1928 that included a mirror, makeup case, and minuscule umbrella. The mesh bags of the 1920s echoed perfectly the sinuous lines of the chiffon and net dresses worn





### HOW THE KELLY BAG GOT ITS NAME

A Hermès Kelly bag takes over eighteen hours to create and is hand-stitched by a single craftsman. Based on a bag originally designed to carry a saddle, the original name for the Kelly was the *Haut a Courroies* (meaning literally “bag with tall handles”), and the first model was refined for use in car and air travel in the early 1930s. Famous women who have carried the bag include Marlene Dietrich and Ingrid Bergman, but these are not the women who made it a household name. In 1956 Grace Kelly was photographed getting out of a limousine holding her Hermès bag in a white-gloved hand. In fact, she was using the bag to shield her pregnant belly from prying photographers. The image ran on the cover of *Life* magazine in 1956 making the Kelly the most famous bag in the world. Luxury accessories were slower to catch the public’s imagination in midcentury America than in Europe, where an expensive handbag was expected to last a lifetime. In France it has long been a bourgeois ritual to present a Kelly bag on a young woman’s twenty-first birthday. In America, the Kelly has also come to represent a treasured prize for a rite of passage and has remained the last word in conservative chic for almost half a century.

by the flappers, and were just large enough to contain a pack of cigarettes, a lipstick, and some coins. While the average office girl of 1930 was content with her enameled Whiting and Davis mesh bag decorated with a deco flower for \$2.94, socialites carried bags studded with pavé diamonds, jade, and emeralds by Cartier, or Van Cleef and Arpels minaudières, evening box bags made of solid gold.

By the late 1930s the spirit of surrealism and Hollywood screwball comedies infused handbag design with a last blast of witty sophistication before the war. Suddenly a bag could be shaped like a Daimler automobile, a Scotty dog, or a model of the SS *Normandie*, complete with miniature metal steam vents (this bag was sold as a souvenir aboard the ship in 1935). The designer who embodied this irreverent spirit best was Elsa Schiaparelli. She was the first designer to link the handbag to the concept of celebrity: She decorated a pochette in 1934 with a print of newspaper clippings about herself! Subsequent bags were shaped like bouquets and inverted balloons. During World War II, handbag design took a sober turn, with practical styles prevailing; the return of frankly masculine shoulder bags dominated the decade. Ingenuity and improvisation dominated this decade. Rationing saw women recycling nineteenth century bags for evening

and using everything from men’s suiting to crocheted wool and upholstery cord to craft their own handbags at home. Stealth influenced style and bags were designed with secret pockets, stacked compartments, sliding metal panels and riveted mesh clasps.

As if in reaction to the solidity of 1940s bags, 1950s bags were small, saucy, and (due to the development of plastic technology) quite often completely see-through. Transparent bags were made possible by a new form of hard plastic Perspex known as Lucite. But the lifespan of Lucite as a luxury item was cut short by the invention of injection molding, a process that could make hard plastic bags quickly and cheaply. By 1958 the Lucite bag was available at chain stores and no longer a coveted status symbol. Wealthy ladies had moved on to luxury bags made of crocodile and alligator. The next generation would care for neither.

The handbag in the 1960s seemed eager to shrug off the hang-up of structure and tradition. Bags were made in simple shapes and elaborate inexpensive materials such as wood, straw, cotton, and PVC. Bags could be whimsical, like Enid Collins’ sequined baskets, or psychedelic as in the case of Emilio Pucci’s patterned handbags, but they were rarely staid. Bonnie Cashin’s design mantra “make things as lightweight as possible—as simple as possible—as punchy as possible—as inexpensive as possible” summed up the spirit of the era. The American sportswear designer spearheaded a return to soft, unstructured bags. She coined the term “Cashin Carry” for her 1967 shopper with a coin purse self attached; she made a lunch-box shaped bag with pockets that flipped open on either end, and a hobo bag that included an extra pouch—just in case. She took the everyday tote and dolled it up in acid-bright leather piping and Harris tweed. Designing for Coach from 1962 to 1972, her ideas spawned the slouchy egalitarian style of the 1970s and continue to speak to the preppy elegance of contemporary sports bags. The handbag in the seventies was influenced by the divergent forces of feminism, global travel, status fashion and sport. Unisex styling gave the ‘man-bag’ its brief moment and many rough hewn embroidered denim and handtooled leather shoulder bags were worn by both sexes. Utility style had an impact on materials and both the rip stop nylon ‘Le Sportsac’ tennis bag and the canvas L. L. Bean tote were worn as badges of egalitarian chic and career equality. Designer status bags by Gucci, Dior, and Fendi established jetset style but over-licensing and widespread counterfeiting diluted the power and exclusivity of the logo as the decade progressed. Luxury evening bags of the late seventies and early eighties were exquisite and small. The disco bags by Carlos Falchi, Halston and Judith Leiber were worn almost like jewelry. Prada, the Milanese leather house, was substantially revived when Miuccia Prada introduced a simple leather and rip-stop nylon backpack to their line in 1985. Monochrome and subtly monogrammed, the bag and its’ practical accessories (small wallets and purses) gave the

designer bag a fresh dose of street credibility. The late eighties saw a return to the surrealist spirit in fashion with many French designers approaching the handbag as a witty found object or subverted status symbol. Jamin Puech suspended a marabou powder puff on a satin strap, Christian Lacroix fashioned a gold clutch into the shape of a Byzantine bible, and Karl Lagerfeld shrank the Chanel bag to the size of a bon bon to bounce off the hip. The nineties was perhaps the centuries richest decade for handbag design, almost every year saw the birth of an iconic new bag. In 1993 Lulu Guinness launched her flower pot, a surreal basket bag festooned with silk roses. The following year Kate Spade's top handled square tote became an instant American classic. In 1995 Madame Chirac presented Lady Diana with a small bag of embossed leather with loose gold letters hanging like a charm bracelet from its handles, the 'Lady Dior.' In 1996 Moschino dripped rich brown calfskin over a pristine white handbag, effectively dipping the bag like a strawberry in chocolate. The most famous bag of the decade was launched the following year. The Fendi baguette tucked under the arm (inspiring its title) and was made of rich and unexpected materials: tapestry, handloomed velvet, embroidered denim and exotic skins. The bag changed the fortunes of the company and the face of the handbag in fashion history, as the first bag since the Kelly to become a household name, a cult object and a celebrity in its own right.

Designers have tried to predict what the bag would look like in the twenty-first century. In 1999 Karl Lagerfeld designed the Chanel 2005 bag: a vacuum-formed ovoid handbag with a hard body flocked in neoprene. The all-in-one design of this bag with a handle punched out of its body like a doughnut hole resembled both a laptop case and a futuristic cartoon character. Houses such as Fendi, Prada, Gucci, and Vuitton created dramatic sequels to their best-selling bags.

The logo itself came up for review with aggressive revision and reinvention. Marc Jacobs's first contribution to his post as creative director at Louis Vuitton was to have the 1980s artist Stephen Sprouse tag the name of the house in graffiti lettering across a zip-topped structured bag. Released in 2000, this bag led the charge for staid houses to revise their image radically. John Galiano's designs for Dior from 2000 on, have evoked Cadillac dashboards, car headlights, punk rock kimonos, and miniature riding saddles in arresting materials like red patent leather and acid-washed denim.

The impetus behind the capital and artistic risk of issuing radical bags for the classic labels has been both prestige and money. When a label launches a successful bag the corporation's stock can rise dramatically in value. Handbags have also become the stylistic mascots for designer culture. In the 1940s one wore the perfume of Chanel; in the early 2000s one wears the bag to attain the same cachet. The quest for an "it" bag dominates the field. After the initial long-running success of the

baguette since its launch in 1997, Fendi presented the croissant (shaped like a crescent moon) in 2000, followed in 2002 by the Ostrich, a 1970s-inspired shoulder bag with zipped side panels and a beaten metal panel something like a Roman breastplate, and a succession of bags that mimicked the bouffant folds of a chef's hat or fanned outward in concentric tiers of leather, fabric, and skins. Outlandishly organic designs have vied for attention by creating a sexy alternative to the top handle bag. Tom Ford for YSL's "Nadja" bag (2003) resembled a massive suede rosebud or ruffled labia depending on your view. The studded Domino bag by Sonia Rykiel (2001) squashed under the arm like a comfortable designer dim sum, and Marc Jacob's "Venetia" with its massive buckles, chunky pockets, and top stitching set a powerful trend for utilitarian bags with cartoonish proportions in saturated colors.

The first four years of the twenty-first century saw the most intense diversity in handbag design and equally intense competition between designers. When Madonna, Gwyneth Paltrow, and Kate Moss began to carry the saddlebag designed by Nicholas Ghesquiere for Balenciaga, the rather plain distressed leather hobo with front zips and trailing tassels became a cult. When characters on the TV show *Sex and the City* obsessed about owning a red Hermès Birkin bag, the yearlong waiting list for the bag doubled and then tripled. In terms of fame, the Hermès Birkin bag has now eclipsed the Hermès Kelly or perhaps it has simply become the Kelly bag of its generation, being softer, larger, and slightly louder than its predecessor.

While famous designer label bags lead the trends for mass-market fashion, there is room for a backlash or a return to one-of-a-kind bags made by hand. In the Victorian era bags assumed a split identity. The formality of a leather shopping bag or traveling case and the eccentricity of a little silk evening purse stitched from remnants or decorated with a hand-embroidered poem struck the contrast between social duty and private pleasure, professional production and home crafts. As the handbag grows more and more commodified, streamlined, and hyped, a return to more individual shapes and materials seems increasingly possible. The bag began as a simple vessel for private needs. Despite the advances of technology and the far-reaching tentacles of advertising, this is where the handbag may return. A rejection of luxury culture might produce the most original bags of the twenty-first century, and the most personal.

See also **Cashin, Bonnie; Europe and America: History of Dress (400–1900 C.E.); Ford, Tom; Hermès; Pucci, Emilio.**

#### BIBLIOGRAPHY

- Ettinger, Roseann. *Handbags*. Atglen, Pa.: Schiffer Publishing, 1999.
- Hagerty, Barbara G. S., and Anne Rivers Siddons. *Handbags: A Peek Inside a Woman's Most Trusted Accessory*. New York: Running Press, 2002.

Johnson, Anna. *Handbags: The Power of the Purse*. New York: Workman Publishing Company, 2002.

Steele, Valerie, and Laird Borelli, *Handbags: A Lexicon of Style*. New York: Rizzoli International, 2000.

Wilcox, Claire. *Bags*. London: Victoria and Albert Museum, 1999.

*Anna Johnson*

**HAND SPINNING.** See **Homespun; Spinning.**

**HANDWOVEN TEXTILES** The category handwoven textiles encompasses a broad spectrum of woven fabrics formed by interlacing two sets of elements—warp and weft—with the aid of a loom, which is a device for maintaining tension on the warp elements. Whether the loom is primitive, mechanized, or computer-driven, it is considered a handloom if it is operated directly by the weaver. Even though various types of power looms have been developed since the industrial revolution, handweaving persists in many parts of the world as an expression of ethnic culture, as a cottage industry or small-scale artisan workshop, as an avocation, and as an art form.

#### Handwoven Textiles in Interior Design

Handwoven cloth contains irregularities not usually present in industrially-produced cloth—a quality often considered desirable by contemporary artists and designers. The rich colors and designs of traditional cultural textiles are appreciated by collectors and continue to provide sources of inspiration to handweavers and artists, as well as to designers in the textile industry. Noted textile designers such as Jack Lenor Larsen formed unique collaborations with traditional handweavers around the world to produce unique and distinctive fabrics for interiors, using traditional design elements and woven by traditional means. Such collaborations not only produce exciting new textiles; they also help the cultures involved to maintain art forms that are struggling to survive in the current global economy.

Handwoven rugs are popular items of interior decor that may be imported from traditional textile workshops in countries such as Turkey and China, or they may be unique works of art designed by contemporary artists. Liturgical fabrics specially handwoven to adorn houses of worship comprise a specialized market for this specialized group of artist-weavers. Other handwoven items created for interiors include afghans or throws, table linens, and wall hangings. A few handweavers specialize in reproducing historic fabrics for historic dwellings and reenactments.

Many artist-weavers are attracted to using hand-manipulated weaves, such as tapestry and supplementary-weft techniques, that allow for the creation of free-form and pictorial designs to create tapestries and wall hang-

ings for art galleries and collectors. A growing field for artist-weavers is the application of digital technology to handweaving to produce computer-generated designs on complex looms.

#### Traditions and Looms

Cultures with living traditions in handwoven textiles made on simple looms are numerous and can still be found in many parts of the world, including Mexico and Guatemala, Peru, Bolivia, Ghana, Nigeria, Morocco, Turkey, China, Burma, Japan, Thailand, Vietnam, Indonesia, and the Philippines.

Fabrics woven on simple two-bar looms such as the backstrap loom, tend to be narrow widths (12–14 inches) of warp-dominant or warp-faced plain weave, for ease in operating the loom. The so-called primitive fabrics produced on these looms, usually by women, are often decorated with elaborate supplementary-weft techniques (brocade) inserted between the rows of the plain-weave ground; or with supplementary-warp techniques (pickup weaves) worked in a similar manner. Such patterns involve hand-manipulating selected threads during the weaving, and their complexity is limited only by the weaver's patience and imagination.

Many cultures make use of simple, two-bar looms to create their traditional folk costumes. Such weavings are often pieced together from rectangles of narrow, four-selvage cloth and may be further embellished after assembly. Two-bar looms may also be used to create shawls, cloths for wrapping and carrying, bags, rugs, tent fabrics, and other utilitarian fabrics. From the brocaded huipil, or blouse, worn by indigenous women of Guatemala and Mexico, to the sarongs of Indonesia, traditional handwoven garments are associated with personal identity and cultural pride.

Weft-faced weaves such as tapestry can be woven on an upright version of the two-bar loom. Well-known products of upright looms include Turkish rugs in various weaves such as pile, kilim (tapestry), and soumak; and the Navajo rugs of the Southwest United States made in tapestry weave.

A simple foot-manipulated loom, the tripod loom, is used by men in West African countries such as Nigeria, Senegal, and the Ivory Coast, to weave narrow cotton strips for kente cloth. These strips are pieced together to make large cloths for men's ceremonial dress.

Handwoven fabrics created on mechanized handlooms such as treadle looms can range from simple, textured effects achieved with novelty yarns in plain weave, to fabrics with pattern repeats that become increasingly complex as the available number of loom shafts increases. India, China, Japan, and Thailand are well-known for their production of handwoven silks, cottons, and other natural fibers. Guatemala and Mexico produce handwoven cotton fabrics. Cottage-industry handweaving of woolens persists in Scotland and Ireland.





### CONTEMPORARY HANDWOVEN CLOTHING

Artists who create art-to-wear garments often prefer the distinctive texture and character that handwoven cloth adds to their expressive works. Contemporary handwoven clothing has undergone an evolution in sophistication since it became popular as an art form during the 1960s. As a greater variety of threads became available, and as handweaving equipment became more sophisticated, so did handwoven clothing design. Woven fashions in the 1960s and 1970s were inspired by ethnic clothing styles and were usually designed using rectangular shapes that could be put together with minimal cutting or sewing. Weavers at that time also challenged themselves to create garments “shaped on the loom” by weaving pattern pieces to shape according to a pre-drawn cartoon. By the 1980s, the increasing availability of fine yarns and luxury fibers combined with the increased availability of complex looms, inspired handweavers to create drapeable fabrics for fashionable, tailored garments and to explore the expressive possibilities of weave structures in fashion design and wearable art. Handweavers today create complex textiles through creative combinations of weave structure and use of textured yarns. They may also employ techniques such as warp painting or ikat dyeing of the threads before weaving, or may apply surface design techniques such as painting, printing, and foil transfer to embellish the finished fabric.

#### Markets for Handwovens

In addition to textiles produced for the interior design trade mentioned above, commercial markets for handwovens in the United States and Europe include folk art galleries, museum shops, craft galleries and art and craft fairs, wearable art galleries, and contemporary art galleries. In the many countries with cultural textiles traditions, sales are realized through tourist markets, specialty shops, and government-supported handcraft outlets. Artisan cooperatives may export textile products through fair trade markets, which guarantee the artisans a fair wage for their work. Export and import of handwoven yardage occurs through the international textile trade or through specialty importers.

See also **Ikat; Kente; Loom; Tapestry; Weave, Double; Weave, Pile; Weave Types; Weaving.**

#### BIBLIOGRAPHY

- Alderman, Sharon. *Handwoven Tailor Made*. Loveland, Colo.: Interweave Press, 1982.
- Brown, Rachel. *The Weaving, Spinning and Dyeing Book*, New York: Alfred A. Knopf, 1984.

Collingwood, Peter, and Ann Sutton. *The Craft of the Weaver*. Asheville, N.C.: Lark Books, 1983.

Hecht, Ann. *The Art of the Loom: Weaving, Spinning and Dyeing Across the World*. New York: Rizzoli International, 1989.

*Karen Searle*

**HARTNELL, NORMAN** Norman Hartnell (1901–1979) was Britain’s most successful and distinguished mid-twentieth-century couturier. He was the first in a wave of London-based designers to emerge in the 1920s and 1930s who offered wealthy British women an alternative to patronizing a court dressmaker or purchasing a Paris-designed model. His graceful, feminine designs, which combined dreamy nostalgia with fairy-tale glamour, appealed to English sensibilities. He excelled at making dresses for grand entrances and was equally at ease designing court-presentation dresses for debutantes and stage costumes for actresses. The latter were sophisticated and sexy as well as glamorous, but Hartnell is remembered for the romantic, quintessentially English gowns that he designed for the upper classes and the royal family. His role as dressmaker to Queen Elizabeth, consort of King George VI, and Queen Elizabeth II won him international recognition and honors. He was nominated an *officier d’académie* by the Institut de l’éducation nationale de France in 1939 and was given a Neiman Marcus Award for contemporary influence on fashion in 1947. In 1977 he became the first fashion designer to be knighted.



**Norman Hartnell.** Britain’s most successful mid-twentieth-century couturier, Norman Hartnell was best known for designing glamorous dresses for Britain’s upper class and royal family. He was the first fashion designer to be honored with knighthood, in 1976. © HULTON-DEUTSCH COLLECTION/CORBIS. REPRODUCED BY PERMISSION.

The theater, ballet, fine art, and the natural world inspired Hartnell. As an undergraduate at Cambridge University, he neglected his architectural studies to design for the university's amateur dramatic societies and then dropped out of school to try his luck as a dress designer. After working briefly as a sketch artist, he set up on his own in 1923 and in 1934 moved to 26 Bruton Street. He made his name designing for debutantes, society weddings, and charity galas, many of which required fancy dress and Hartnell's talents as a stage

designer. In 1942 he was a founding member of the Incorporated Society of London Fashion Designers and was named president several times. After World War II, Hartnell was the largest couture house in London, employing a staff of 385.

Hartnell designed clothing for members of the royal family from 1935. His most legendary commission was the all-white wardrobe he designed for Queen Elizabeth for her 1938 state visit to France, when she was still in mourning for her mother. Hartnell and the photogra-



Commenting on how the creative impulse is evoked, Hartnell remarked, "Who can say exactly . . . ? A wax-white magnolia in the moonlight is a debutante dancing at Hurlingham. Swans on the lake may turn into a young woman in white arriving to cut the cake at Queen Charlotte's Ball, and a farmyard is redolent of sporting tweeds." (Hartnell, p. 82)

pher Cecil Beaton created a lasting image for the queen that was fresh and feminine but unmistakably regal. In 1947 he designed Princess Elizabeth's wedding dress and, six years later, her coronation robes. Hartnell relished the symbolism and pageantry of British ceremonial and found embroidery, which had already become his signature, the perfect medium for conveying the gravity and glamour of monarchy.

Drama, color, and light suffused Hartnell's designs. He enjoyed working with soft, floating fabrics, particularly tulle and chiffon, and with plain, lustrous silks, which provided the perfect foil for his spectacular, eye-catching embroideries. He was the master of the special-occasion dress that flatters and dignifies both wearer and occasion with consummate tact. His legacy to the future lay in his Englishness, in his creative and romantic engagement with history and tradition, and in his love of spectacle.

See also **Court Dress; Embroidery; Fancy Dress; Royal and Aristocratic Dress; Theatrical Costume; Wedding Costume.**

#### BIBLIOGRAPHY

Brighton Art Gallery and Museums and the Museum of Costume. *Norman Hartnell*. Haslemere, U.K.: South Leigh Press, 1985. Well-illustrated and an excellent overview of Hartnell's career.

Hartnell, Norman. *Silver and Gold*. London: Evans Brothers, 1955.

McDowell, Colin. *A Hundred Years of Royal Style*. London: Muller, Blond and White, 1985.

*Edwina Ehrman*

**HATS, MEN'S** Protection, status, and vanity have always been the prime reasons for wearing hats. A hat is much more than a piece of clothing; it is a cerebral fashion accessory that can mark personality, social etiquette, and lifestyle. The twenty-first century is a relatively hatless age, with the exception of the baseball cap and modern hoods. This might be just a passing fad, but it is socially as significant as trends of the previous era, when men wore proper hats all the time.

There have been hatless periods in history before. Eighteenth-century wigs replaced hats and coiffeurs eclipsed the hatter, but the nineteenth century dictated hats for men again with many important styles still remembered with nostalgia. Post-World War I democratic ideologies, modern infrastructure, and, most importantly of all, the car, all caused the gradual demise of hats. World War II changed social values even more, resulting in youth's imperative right of wanting to look radically different from the previous generation. Yet fashion's pendulum never ceases to swing, and there might well be a time in the future when fashion will demand that heads need to be covered again. Why the fashion for wearing or not wearing a hat fluctuates at different times can only be explained with hindsight of historical and social developments.

The ancient Romans lived in a hatless age but showed their status by wearing metal fillets over their brows. The exceptions were military helmets, worn over a leather cap and held in place by a chinstrap. Northern European tribes wore leather caps before the Roman occupation. An eight-section leather cap, said to be over 2,000 years old, is preserved at the National Museum in Copenhagen, Denmark, which must be the oldest existing man's hat in history.

When Christianity arrived in Europe, the church demanded that the body be covered up with a hooded cloak called *bardocucullus*. Faces were overshadowed by all kinds of hoods as well as by beards, the fashion in England until the Norman conquests over the Saxons in 1066. The French invasion imposed a fashion for clean-shaven faces and short hair, which was often covered by a coif, a close-fitted linen cap, tied under the chin. A variation was the phrygian cap, a soft, close-fitting and pointed hat, inspired by the Phoenician fashion, brought into Europe by traders from the Mediterranean.

Early medieval pointed hoods and capes merged into gorgets (a hood and neckpiece) and coif-de-maille (a metal chain-mail hood). Professional people, such as doctors, wore richly decorated round skullcaps. The first hats with brims, made of straw or felt, were utilitarian and worn by field laborers, shading their eyes from the sun and rain. A soft linen coif, tied under the chin was usually worn underneath a hat, thus keeping long hair in place. In the late thirteenth century, the *chapeau a bec*, a brimmed hat, cocked into a beak shape pointing to the front, became the fashion for young men and was also always worn over a coif. Later on, the *chapeau de fer*, a divergence from the closed metal helmet, provided shade and protection with its cap, brim, and chinstrap.

Headwear became more eccentric in the fourteenth century, with meek and humble hoods developing ever-longer and longer drooping points. The soft lengthy tubes, worn over a gorget, were called liripipes and often matched the then fashionable four- or five-piece outfits. The tube could be up to two feet in length with a long





**Roman legionaire wearing helmet.** Hats, though rarely worn by ancient Romans, were used by the military. They were made of leather and held in place by a chinstrap. © BETTMANN/CORBIS. REPRODUCED BY PERMISSION.

ribbon added, which could be wound around the head in infinite variety. The coif, the gorget, and the liripipe were collectively called the chaperon. A round, stuffed band, called a rondelet, was sometimes added by fashionable jongleurs, the wandering musicians and medieval trend-setters. Further variations were achieved by rolling the gorget up over the forehead or by winding the liripipe around the head, creating a kind of turban style. Added to this complicated arrangement could be a felt bycock hat, a style worn by men and women, which allowed even more variations by splitting or slashing the brims, or by wearing the hat back to front. Diversification seemed infinite with soft tammy berets worn over coifs or draped over brims. Materials varied from robust leather and felt to furs and precious silk velvets in lush colors, matching or contrasting the extravagant medieval outfits.

Hoods and gorgets for warmth continued into the fifteenth century, with hat shapes adding personal identity. Occasionally, the soft gorget was replaced by a

houppeland, a stiff collar cradling the head and tucked under the liripipe or rondelet at the back of the head. The coif was relegated to be worn as a nightcap called cuffie, cappeline, benducci, or bendoni and replaced by close-fitting lined linen caps without chinstraps. Worn under expensive velour or plush hats, this was a practical solution for keeping the inside of a hat clean from sweat and grease. As hoods and liripipes could not be taken off in greetings, they had to be raised by two fingers while bowing, a gesture called "*riverenza di cappucino*." The Vatican influenced social etiquette and with it men's fashion. The becca replaced the liripipe and became a social attribute with its long and flat band, hanging down over the right shoulder, draped over the chest, or tucked into the belt. To greet a lady, a man had to raise his hat with his right hand, while holding the streamers of the becca with his left. The becca's practical advantage was in securing the hat when it was slung over a man's shoulder, a custom still used on ceremonial robes of the Order of the Garter.

Men's fashion changed from a slim, tall medieval silhouette to a short, stocky look in the sixteenth century, established in England by King Henry VIII. Flat, wide berets complimented the style best. Worn straight or at an angle with six- or eight-sided stiff brims underneath, they were known as "bonetes." Brimmed hats developed into quite flamboyant styles, generally called "beavers" after the fur used for felting. These felt hats were often trimmed with real fur, which was also used for rondelets and under brims.

Plumes of swan feathers and ornamental brooches, gold plaques and crests enhanced a look of prosperity. The coif changed to the caul, a wide-netted snood to be worn under the hat or inside the house. Young men liked hoods with very long points down to the floor, which could be wound around the head. Prosperous merchants wore cushion hats, stuffed berets with voluminous rondelets, while older men preferred high, flat birettas, usually in bright scarlet red.

During the Elizabethan era, men's hats changed to capotains, brims with high crowns, lavishly decorated with gold and silver braids, Vandyke lace, as well as exotic plumes from the newly discovered Americas. In England, all men above the age of six had to wear a hat by law. This court edict was proclaimed in order to foster the hat trade.

In the seventeenth century, hats diversified even more extravagantly. Wide cocked-up brims with diamond studded ostrich feathers drooping over the edges were the fashion for the new romantic male idol, "the cavalier," an image immortalized in numerous paintings. The cavalier's beaver hat, posed on long, flowing love locks was the perfection of elegance, a peacock look, that took time and wealth to perfect, which might possibly have been the reason why wigs came into fashion. Wearing a periwig, made of human or of horse hair under one's hat, was a simpler, less time-consuming option, allowing even

more variations in color and style. The perfect new stylish hat was the tricorne, which like wigs was in fashion up to the end of the eighteenth century. An individual note was achieved by wearing the hat either pointing to the front or to the side and by adding different decorations like feather fringes and cockades; very important in all military headwear.

Fashion in the eighteenth century was dominated by hair and wigs leaving hats to be carried in the hand and raised in greetings rather than worn. Coiffeurs created wigs of great varieties, powdered toupees or center-parted curls with queues and pigtailed hanging down at the back. The tricorne was still worn, but changed shape by being flattened or “pinched” at the front, which was a foretaste to the two-cornered “bycocked” hat. Beaver fur, (*castor* in French) was still used as the raw material for felting, but was often mixed for economical reasons with rabbit fur and then called “*demi-castors*.” Both tricorns and elaborate wigs lost their appeal at the end of the century. European fashion was influenced by the French Revolution, when men shedded notions of aristocracy in favor of egalitarianism. Round, small-brimmed and light-colored felt hats, trimmed with simple bands and buckles, worn over natural-colored hair were “*de rigueur*.”

Curiously, the start of the nineteenth century heralded a new age for men's hats in the Western world, which reached its zenith at the turn of the twentieth century, when no gentleman would ever step out of his house without wearing a hat. Men's clothing was dictated by sobriety and egalitarianism and hats fulfilled an important role in subtly marking differentials, personal and professional ones, as well as social class distinction. Top hats, bowlers, derbies, boaters, fedoras, panamas, and cloth caps were all created during this century and lasted well into the twentieth century.

The black silk topper was the first in line. Developed from the high felt stovepipe hat, it became the hat worn by postrevolution aristocracy and an emblem of conservative capitalism. Its origins were far less formal. Like many other hats in history, the topper, also known as “*chapeau haut de forme*,” was a French design, at first causing outrage and dismay in London in the 1790s. According to the *Mayfair Gazette*, this new tall black hat “frightened people, made children cry, and dogs bark.” John Heatherington, the London haberdasher who dared to wear it, was arrested and charged with “inciting the breach of the peace.” Despite this turbulent beginning, the high black hat was gradually adopted by gentlemen of distinction in the West.

The construction and making of the high topper was innovative, too. The hat was not shaped in beaver felt but constructed from stiffened calico, which was covered with silk plush fabric and brushed around repeatedly until smooth and shiny. Mercury was used to enhance the hat's blackness and was later discovered to cause mental disorder, hence the popular term “mad as a hatter.” The height and the shape of the crown varied, the tallest be-



**Stetson hats on display.** Established in the late nineteenth century, the well-known Stetson company produces hats that evoke a masculine feel and a sense of history in the wearer. © DAVE G. HOUSER/CORBIS. REPRODUCED BY PERMISSION.

ing the “kite-high dandy,” with a height of  $7\frac{3}{4}$  inches (21cm). The diameter of the flat top varied as well and with it the “waisted” shape of the chimney crown. Toward the end of the nineteenth century, a collapsible version of the hat was devised, known as “*chapeau claque*” or “*chapeau Gibus*,” after its French inventor. This ingenious design could be folded flat—concertina-fashion—and sprung back into shape by the flick of the fist, thus making storage much easier.

The bowler hat, called derby in the United States, was designed in 1849 at the height of the industrial revolution in Britain. Like the top hat, it quickly became a classic wardrobe item and a quintessential badge of Englishness. Named after John and William Bowler, hatters from Stockport, an industrial city in the north of England, it was to become the first mass-produced hat in history. A young English aristocrat who wanted a new hunting hat ordered the original design. Lock and Company, hatters of St. James's in London, since 1676, had been given a brief to supply a brown, round-crowned felt hat, practical and hard wearing, but also dashing and modern. Most importantly, the hat was to be hard and protective as it was to be used for riding. The making of felt hats was traditionally done by small factories in South London, who experimented with stiffening of felt in various ways. A substance called shellac was perfected by mixing a dark treacle-like extract from a parasite insect found in Southeast Asia with methylated spirit. The felt hoods were manually rolled and beaten in the hot and steaming mixture, before being blocked and dried on wooden hat blocks. The procedure was arduous and dirty, but the key to mass production, making the hat affordable to the middle-classes.

The industrial revolution in Britain and all over Western Europe brought important social changes and a shift from agriculture to factories. Factories needed not



**Actor Maurice Chevalier in Boater hat, ca. 1930s.** Men's hats have long served a variety of functions, from head protection to fashion statement. Their form and function have largely been determined by the age and culture in which they developed.  
© JOHN SPRINGER COLLECTION/CORBIS. REPRODUCED BY PERMISSION.

only workers but also managers, bookkeepers, and accountants, all new middle-class men who traveled on the newly invented railways wearing black bowler or "iron hats." With its sturdy, solid look the hat was the perfect fashion and style accessory for social climbers in Victorian Britain: a smart, discreet hat that turned every man into a gentleman. The earl of Derby introduced the hat to the United States, hence the name given to it there.

The bowler held its place in fashion for over one hundred years, its distinctive silhouette making it the most widely recognized hat image in history. The bowler hat was immortalized in art, comedy, and literature, and it is still exploited in advertising today. Charlie Chaplin made the hat famous in his satiric silent films of the early 1920s, a comedy act, which was followed by Laurel and Hardy a few years later. Samuel Beckett put bowler hats on the tramps in his famous play, *Waiting for Godot* ("He can't think without his hat," says one of the characters.) Bertolt Brecht's *Threepenny Opera* features bowler hats and Stanley Kubrick's anarchist in *Clockwork Orange* also wears a bowler. René Magritte's paintings are famous because of the bowler hats on his surrealistic figures. Sculpture has immortalized the hat's image too, in a famous bronze statue with a bowler hat called *The Man in the*

*Open Air* by Ellie Nadelman at the Museum of Modern Art in New York. It epitomizes the link between the Old and the New World, the transition between convention and modernity.

During the early twentieth century, a black bowler hat became synonymous with financial affairs and was the headwear for German businessmen during the years of the Weimar Republic (1918–1933), but the Nazi regime branded it "*Judenstahlhelm*," outlawed it, and used it in anti-Semitic propaganda. The bowler remained the recognizable attire of bankers in the City of London until the 1970s and is still worn by a few city lawyers today.

The homburg was a German hat, similar to the bowler, but with a higher and lightly dented crown and is named after its city of origin. It is said that King Edward VII of Britain saw the hat worn by his German cousin Kaiser William and thus started the fashion in England. British politicians like Winston Churchill and Anthony Eden also liked to wear this hat. The American fedora and the slightly smaller British version, the trilby, are felt hats with dented crowns and brims turned up at the back, and down at the front, shading the eyes. Soft felt hats brought a more casual look to men's fashion, which had changed from black frock coats to suits and raincoats. Franklin D. Roosevelt's fedora helped to change the image of his presidency after the assassination of President McKinley, who had always worn a black top hat. The soft felt trilby was originally a bohemian hat, worn by artists and modern thinkers who wanted to make a stand against the old conservative values of the previous century. In the 1930s and 1940s the hat took on a gangster role in the United States, which was exploited by many moviemakers and film stars. It was also the hat worn by newspapermen, crime reporters, and Mafia bosses, whose shady expressions were obscured beneath the stylish brim.

The panama hat was the summer hat for the modern man around the turn of the twentieth century. The hat was woven using the finest jipijapas straw, flexible enough to be rolled into a narrow tube for packaging and transportation. Panamas were handwoven in Ecuador and shipped through the Panama Canal, which gave the hat its name. Growing and preparing the straw was a lengthy procedure and so was the weaving of a hat, which could take a skilled worker up to four weeks. The finest and costliest panama hat is called a Montecristi fino-fino. With not many skilled hat weavers left in Ecuador, this hat has become a collector's item. Cheaper versions and paper panamas are very popular and commercially mass-produced in many other countries today.

The boater was another popular straw hat of the nineteenth and the twentieth centuries. The straw was plaited, sewn in a spiral, stiffened and blocked hard into its distinct shape of a flat crown and stiff flat brim. The design of the boater is derived from the shape of sailor's hats and suited to the debonair informal look men liked around the turn of the twentieth century.



The Stetson is a truly American hat, stylish, protective, and unmistakably masculine; a hat of the prairie and the most treasured possession of a cowboy, it evokes silver-screen bravery and passion of the Wild West. Its origins are in Philadelphia, where John Batterson Stetson established his first hat factory in the 1880s, which was to grow into one of the great American enterprises of the twentieth century. Having learned the principles of hat making from his father, John Stetson first sought fame and fortune by trekking 750 miles to the west, and felting and making hats by the campfire for his fellow travelers. He did not find gold, but his skills and tenacity helped him build the largest hat empire in the world. The making of a modern Stetson is still based on the old techniques of felting and blocking, requiring thirteen different stages in production, thus making the hat the costliest item of a rancher's clothing. The image of the battered cowboy hat has given way to a range of stylish models for Texan businessmen, topped by the famous "Boss of the Plains," as worn by J.R. of the famous 1980s TV series *Dallas*.

Cloth caps are flat hats with visors traditionally cut and sewn from woolen cloth. The image of the cap was a modest, practical one in keeping with a workingman's life. The saying, "cap in hand," illustrates the social position of the cap—as does the Russian poet Alexander Blok's verse, "Caps tilted, fag drooping, everyone looks like a jailbird on the run." The cap, like other hats, changed its image and is worn in the early 2000s by wealthy gentlemen when shooting grouse or playing golf rather than by laborers going to work at a factory. Cap-makers or cappers, also made livery caps, military caps, and various styles for sports caps, like the baseball cap, which has become the universal hat of youth culture in the twentieth and twenty-first centuries.

Finally, the beret, which was in existence long before the twentieth century, has evolved from a French Pyrenean shepherd's hat to the most widely worn military hat in the world. The colors and badges may vary, but the beret is now a universal soldier's hat as well as the favorite hat of revolutionary guerrilla groups. A French mountain regiment, *les chasseurs alpins* always wore dark red berets and presented one to the British Field Marshal Montgomery after World War I. He wore this beret, called "*tarte alpine*" during his command of the British forces during World War II.

See also **Hats, Women's; Headdress; Helmet.**

#### BIBLIOGRAPHY

- Amphlett, Hilda. *Hats, A History of Fashion in Headwear*. Mineola, N.Y.: Dover Publications, Inc., 2003.
- Hopkins, Susie. *The Century of Hats*. London: Aurum Press, 1999.
- McDowell, Colin. *Hats, Status, Style and Glamour*. London: Thames and Hudson, Inc., 1992.
- Robinson, Fred Miller. *The Man in the Bowler Hat: His History and Iconography*. Chapel Hill: University of North Carolina Press, 1993.

Whitbourn, Frank. *Mr. Lock of St. James's Street*. London: Frank Heinemann Ltd., 1971.

Susie Hopkins

**HATS, WOMEN'S** Hats are head coverings with a crown and usually a brim. They are distinguished from caps that are brimless but may have a visor. Hats are important because they adorn the head, which is the seat of human rational powers, and they also frame the face. Women's hats have often been differentiated from men's headwear, although in modern times, many women's hat styles have been copied from men's.

Hats are material communicators that indicate gender, age, social status, and group affiliation. They also serve as ceremonial symbols and enhancers of sexual attractiveness. As a sculptural art form, hats may be described and interpreted in terms of shape, color, textured materials, adornments, proportion, and scale to the wearer.

While hats have been universally worn, their historical development within the Western European fashion world will be the focus here. Women's hat fashions began in the Renaissance and grew dramatically with the nineteenth-century industrial revolution, sometimes called the "Golden Age" of millinery, which lasted until the mid-twentieth century.

#### Origins

The woman's hat may have its origin with a turbanlike head wrap or pointed cap as documented in Neolithic cave paintings at Tassili, Algeria (c. 8000–4000 B.C.E.) and later Mesopotamian sculptures (c. 2600 B.C.E.) Evidence for a variety of shaped hats comes from Crete (c. 1600 B.C.E.) via polychrome terra-cotta female figures wearing several types: the high sugarloaf style, the flat beret, and the tricorne with rosettes, curled plumes or ribbon decorations, which may have association with fertility rituals.

According to Classic, fifth-century B.C.E. painted vases, Greek women were more likely to wear their hair on top of the head secured by a bandeau or net caul. The Greek wide-brimmed straw petasos, worn by both women and men as a sun protector, was also adopted by Romans. Because of modesty and religious reasons stemming from Saint Paul's admonition to the Corinthians that women must cover their hair while praying, wealthy Christian women in the Middle Ages wore draped veils, hoods, or wimples indoors and practical wide-brimmed hats over the wimple for traveling. Peasants wore wide hats over skullcaps or hoods while working in the fields.

#### Renaissance Humanism: Fashion Begins

With the emergence of Renaissance humanism in fifteenth-century Italy came capitalism stimulated by overseas trade and increased bourgeoisie wealth accompanied by an appreciation of secular portraiture and clothing as art forms. Thus was born the phenomenon of Western

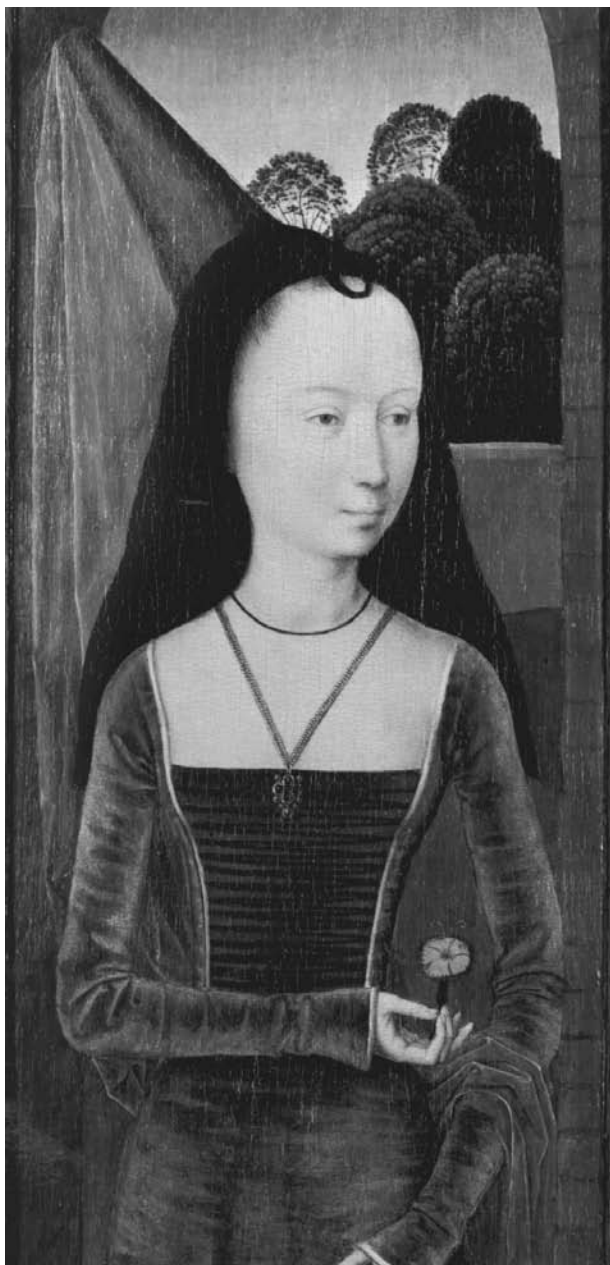

**Young Woman with a Pink**, by Hans Memling, 1485–80. Throughout history, women's hats have served numerous functions, including communicating gender, age, social status, and group affiliation. THE METROPOLITAN MUSEUM OF ART, THE JULES BACHE COLLECTION, 1949. (49.7.23) REPRODUCED BY PERMISSION.

fashion, whereby individuals aspiring to privileges enjoyed by nobles acquired clothing and hats, not just for functional reasons, but capriciousness. Within a short time, this emphasis on individual materialism spread to many regions of northern Europe.

Some of the most elaborate hats women have ever worn appeared in the late-medieval and Renaissance courts of France, Flanders, and Bavaria, including the tall

cone-shaped, silk-and-velvet steeple hat with draped veil (hennin), depicted in modern publications of medieval fairy tales, and the brocaded silk, stuffed bourrelet created into enormous horns, reproduced with proto-feminist writings by Christine de Pisan as *The Book of the City of Ladies* (1405). Other contemporary styles included the large, round, beehive-shaped hat popular in Germany and an English silk-gold braid with pearls covered by a wired gauze wimple. Scholars have noted the possible cross-cultural source for these excessive headpieces as coming from Turkish styles at a time when the Ottomans were expanding their control into eastern Europe not far from Vienna. In response to these feminine excesses, Catholic churchmen were known to encourage Christians to yell insults aimed at humiliating women wearing such outlandish headwear. In some places, sumptuary laws were issued limiting the size, number, and materials that could be devoted to women's hats in an effort to control excesses and maintain class social structure.

### Court Fashions

From the sixteenth century on, hat styles were largely influenced by royal tastes, from the English Tudor gable hood to the Elizabethan wigs and a wide variety of velvet, taffeta, silk, felt, leather, and beaver hats, many based on men's styles.

The seventeenth century saw a white lace wired or starched "Mary Stuart" hood as popular for indoors, and the wide-brimmed, plumed felt or beaver hat for outdoor riding associated with Queen Henrietta Maria. The English Restoration Queen Catherine of Braganza, Portugal, still wore this "cavalier" style for riding in 1666.

In portraits, court ladies during the reign of Charles II were frequently depicted in pastoral costume as "shepherdesses" holding contrived sun-protector hats made of heavy fabric, like velvet. A century later, the pastoral look was still in vogue, but the hats had changed to more realistic, broad-brimmed straw versions called bergère, decorated with ribbons, artificial flowers, and large plumes, reaching their zenith with Marie Antoinette as painted by Vigée Lebrun. Although many of these hats were made locally from country-style materials, the finest smooth straw was imported from Leghorn, Italy, to northern markets and widely used by fashion milliners.

During the late seventeenth century, France became Europe's fashion center under the leadership of Louis XIV. One of the most visually striking headpieces of this era was named for the king's mistress. Supposedly Mlle. Fontanges was out riding when her hair became caught on a tree branch. When she tied it up with ribbon (possibly her lace garter), the *fontange* was born. It metamorphosed into a complex tiered and ruffled architectural-like structure of muslin, lace, and ribbons built up onto a round wire base. Masked balls and carnival festivals provided a venue for women in Venice, Rome, France, and England to wear fantasy headwear, including tricorns, flower basket hats, and exotic Eastern tur-

bans. After living in Turkey for two years as wife of Britain's ambassador, Lady Mary Wortley Montagu was influential in popularizing the turban as an aristocratic women's style in England.

Throughout the eighteenth century, milliners competed with wigmakers for setting headwear fashions. This may be why in Georgian England, enormous crowned hats with stiff lining and gigantic plumes became the mode, copied from French styles set by Marie Antoinette. Some were associated with unusual events, such as the balloon hat, named for Vincenzo Lunardi who in 1784 ascended in a hot-air balloon. Nevertheless, interest in fashionable hats continued to be stimulated by the early hand-colored fashion-plate publications such as *The Lady's Magazine* (London, c.1760–1837) and *Galerie des Modes* (Paris, 1778–1787).

### Middle-Class Fashions

With the social upheavals of the French Revolution, aristocrats lost their political, social, and economic privileges; those who survived were careful to distance themselves from the wigs and extravagance of the *ancien régime*. New, simpler hats associated with prevailing middle-class values became popular, although exotic turbans continued, with possible influences from African head wraps.

Throughout the nineteenth century, reflecting ideals of Romanticism, the ubiquitous chin-tied bonnet, with its numerous variations prevailed, from the calash and its folding hoops like a covered wagon, to the poke bonnet that extended far outward. With elaborate silk, lace, floral, feather, and artificial fruit trimmings, bonnets by mid-century reflected the married woman's status as queen of her home and symbol of her husband's financial success. The man's top hat communicated the same message, and added social status. This fashion persisted through the remainder of the nineteenth century and into the twentieth.

Large emporiums such as Bloomingdale's in New York, Marshall Field's in Chicago, and Goringes in London began to spring up in cities providing ready-made and custom-designed hats in their millinery departments to a growing middle-class clientele. Rural dwellers in the United States could learn of new fashions from magazines such as *Godey's Lady's Book* (1830–1898) and obtain ready-made hats and bonnets at reasonable prices through mail-order catalogs, beginning with Montgomery Ward in 1872 and Sears Roebuck after 1886.

### Millinery Industry

Beginning in the sixteenth century, "millinery" referred to fine artifacts for women, such as ribbons, gloves, and straw hats sold by men around Milan, Italy. By 1679, milliners were dressmakers who also made or sold women's hats, bonnets, headdresses, and trims. Newspaper advertisements indicate that millinery shops abounded by the eighteenth century in European and American cities, although owners were usually only known locally.



**Jacqueline Kennedy in pillbox hat.** Jacqueline Kennedy made the pillbox hat famous during her brief tenure as First Lady, and its popularity swept across the country. © BETTMANN/CORBIS. REPRODUCED BY PERMISSION.

The first internationally recognized milliner was Rose Bertin (1744–1813), *marchande de modes*, whose luxurious salon, *Le Grand Moghul*, on rue Faubourg Saint-Honoré, Paris, became the focal place for attractive designs with ribbons, laces, and trimmings along with the latest social gossip. Her most important client was Queen Marie Antoinette until the royal execution in January 1793. Bertin's business records preserved at the University of Paris reveal clientele to include nobility from Russia and England.

The industrial revolution of the nineteenth century affected the millinery industry in many ways. A new sewing machine, introduced in America and sold abroad, meant large quantities of hats could be produced quickly at low prices. Manufactured hats could be stored and sent to wholesalers for sales in department stores or for overseas export. While trains and ships assisted mass-marketing distribution, overall Paris was still considered the center for elite, high-fashion hats. Wealthy women traveled to Paris for purchases, and store milliners from London and New York made annual pilgrimages to





**Marie-Antoinette.** This portrait of Marie-Antoinette by Elisabeth Vigée-Lebrun illustrates the pastoral “shepherdess” look of French court ladies during the eighteenth century. The look was typified by broad-brimmed straw hats decorated with ribbons, flowers, and large plumes. VIGÉE-LEBRUN, ELISABETH. MARIE-ANTOINETTE, TIMKEN COLLECTION, IMAGE © 2004 BOARD OF TRUSTEES, NATIONAL GALLERY OF ART, WASHINGTON. REPRODUCED BY PERMISSION.

bring back the “latest” modes and trimmings for their home customers. Millinery ideas and advice were also made available to wide audiences from subscription magazines as *Harper's Bazaar* (1867– ) in the United States, *Townsend's Monthly Magazine* (1823–1988) in England, and *Le Follet* (1829–1892) in France.

### Folk Costume Hats

Another clothing-and-hat trend took place in Europe outside aristocratic fashion circles during the nineteenth century. With the relaxation of sumptuary laws regarding clothing, particularly after the French Revolution, European peasant artisans, encouraged by nationalism, began to express their ethnic affiliation through elaborate outfits worn for Sunday religious services, dancing, and festivals. These colorful costumes and hats, still worn by villagers and townspeople, serve as visual representations of community and marital status to be worn on special occasions. The women's hats are usually straw, felt, or other natural materials, and because of their multi-colored festive styles, they have served as inspiration over decades for twentieth-century fashion milliners, who may

re-create the styles with new, synthetic materials. Occasionally referred to as “ethnic-chic,” examples include the bead-and-sequin velvet Basque beret, the Tyrolean felt sport hat, the “pakable” rayon knotted turban, Central Asian styled velvet-and-pearl pillbox, and the cellophane Breton.

### Unisex Sports Headwear

Beginning in the 1860s, as the middle class was growing and enjoying increased leisure activities, men's tailoring techniques were first applied to women's dress. Slightly flared skirts replaced the older crinolines and were complemented by formal suit jackets. Likewise, the fanciful, highly decorated bonnet of earlier decades gave way to more simple, masculine-style headwear. These styles represented for the “New Woman” a sense of physical freedom through sports and political independence via the suffrage movement.

For outdoor sports, women wore the white linen peaked cap while rowing and yachting; and the plain flat-top, hard straw boater for cycling and later automobile driving. Boaters could be adapted for formal wear embellished with bird feathers or plumes.

Other hat styles shared by both genders included the stiff felt, round-crown bowler, or derby, and black silk top hat for horseback riding; the woolen tam-o'-shanter for lawn tennis, badminton, or cycling; the fore-and-aft as a hunting cap; and the fedora for archery or golf. In winter, knitted stocking caps served for bobsledding, ice sailing, and skating. Indoors, the Breton was considered appropriate for bowling or roller skating, known as “rink-ing.” This trend of women's involvement with sports by wearing unisex hats or caps continues to the present. As spectators, they wear the contemporary baseball cap to league games, and as golfers, on the links.

### Twentieth Century

World War I (1914–1918) brought about dramatic changes in women's clothes, hairstyles, and hats, creating a lucrative environment for entrepreneurial designers. Throughout the 1920s, short skirts, bobbed hair, and the cloche, or bell-shaped hat, were the mode on both sides of the Atlantic.

Paris, however, remained the fashion center with trend-setting designers as Elsa Schiaparelli, Cristóbal Balenciaga, and Agnès introducing synthetic materials and abstract shapes. New York and Hollywood also began attracting millinery talent from Europe. Hattie Carnegie from Austria first worked in New York at Macy's before opening her own shop and eventually creating a millinery empire with a thousand employees. French-born Lilly Daché trained with Suzanne Talbot and Caroline Reboux in Paris before arriving in 1925 at New York, where she, too, worked for Macy's before opening her own salon, which led to a multimillion-dollar, international business and fame for her turbans, floral designs, and the “half hat.” John-Frederic's hats resulted from the partnership

of John Piocelle (who studied in Paris at École des Beaux Arts) and the businessman Frederic Hirst (1929–1947). Their designs gained notoriety through Hollywood stars like Marlene Dietrich, Gloria Swanson, and Greta Garbo who wore the slouch hat.

Oleg Cassini, son of a Russian count, first worked in Paris before a long career designing for Hollywood studios. While individual designers maintained their own salons for one-of-a-kind headpieces, they also mass-produced less expensive styles for sales through urban department stores.

Sally Victor also got her millinery start at Macy's and by the 1930s branched out into her own business with her husband, Victor Serges. Her hats combined fashion styling with modest pricing aimed at a wide middle-class clientele, including Mamie Eisenhower. A number of twentieth-century couturiers either began as milliners (Coco Chanel) or designed hats, purses, and handbags as complementary accessories to their clothing line (Christian Dior). Throughout much of the twentieth century, hats and gloves were required for attending social events.

During the World War II Nazi occupation of Paris (1940–1944), when rationing curtailed the fashion industry and sales abroad, French women boosted their morale by defiantly wearing outlandish structures on their heads made out of scraps. With the armistice came rebuilding and the renewed claim that Paris would again become the fashion center of the world. By the 1950s, a cadre of influential wholesale and retail millinery clients from abroad attended Paris fashion shows, purchasing rights to copy the latest hat designs for home markets at inexpensive prices.

In New York, Bergdorf Goodman was known to have the best millinery department; its custom-made Halston hats were top of the line. Roy Halston Frowick created the now-famous deep pillbox hat that Jacqueline Kennedy wore to her husband's 1961 inauguration. The hat, designed to be worn back on the head, accommodated the First Lady's bouffant hairstyle. Within months, the pillbox became the rage across America, boosting the millinery industry, and was thereafter known as Jackie's signature hat.

Some historians see President John F. Kennedy's predilection for hatlessness as leading the trend toward eliminating men's toppers for formal attire. Others see the civil rights movement also effecting this change since hats over centuries had served as visible symbols of the class system. Whatever the cause, in the late 1960s, the custom for both men and women of wearing hats to social events began to disappear. "Informality" became the key to clothing modes. Hats were seen as irrelevant, particularly to the younger generation bent on social change and personal independence. Milliners were replaced by professional hairdressers who created self-expressing new hairstyles such as the Afro and cornrows for African Americans. Simultaneously, middle-class women were in-

troduced to the comfort of pantsuits that had no precedents or hat-wearing fashion requirements.

In contrast to the white community, urban African American women never stopped wearing hats. They continue the African tradition that survived slavery of adorning the head for worship celebrations. Combining glamour and holiness, their Sunday hats are colorful, flamboyant, enormous, and plentiful (some own up to 100), made of straws, felts, furs, starched fabrics, adorned with plumes, sequins, artificial flowers, and rhinestones extending the head upward and outward. Their designers, such as Shellie McDowell of New York, whose clientele includes Oprah Winfrey, understand the tastes of black women and their desire for recognition. This unique tradition of black women in church hats has been documented in the book *Crowns* (2000) and an off-Broadway production of the same title.

In England, after a two-decade hiatus, Princess Diana helped to re-popularize the wearing of attractive hats in the 1980s. Her London-based milliner John Boyd and others (Simone Mirman and Graham Smith) continued designing hats for royal family members, while also producing popular ready-to-wear lines; and the talented Stephen Jones struck out into another surrealistic, trend-setting direction related to the shocking punk styles of colored Mohican-spiked hair and the rock generation.

Festivals have also helped popularize hats. From the 1880s to 1940s, supported by the millinery manufacturers, Easter Sunday parades were held in American cities. These encouraged American women to annually buy or re-trim their Easter bonnets, dress-up their daughters, and walk down main streets. The Hollywood film *Easter Parade* (1948) had Fred Astaire and Judy Garland participate in a re-enactment of this New York Fifth Avenue event.

In England, the historic Ascot, weeklong series of horse races, held annually in June and featured in the musical *My Fair Lady*, still reaches its peak of excitement on Gold Cup Day, known since 1807 as Ladies Day, when the men wear traditional top hats, and the Queen, along with hundreds of women from all classes wear spectacular chapeaux. Large picture hats (also called "cartwheels") are the most common, but what gets attention and appears in press coverage are photos of the most novel hats, featuring intriguing images, such as a dartboard, cellular telephone, flying saucers, Astroturf, or a birdcage.

Paris celebrates Saint Catherine of Alexandria, patroness of maidens and milliners, on 25 November. Unmarried women, especially those working in the millinery trade, who are known as "Catherinettes," wear extravagant hats to parties held in their honor. In earlier times, their goal was to catch a husband with the saint's assistance.

A notable effort at reigniting interest in millinery was the 1983 opening of the Hat Making Museum in Chazelles-sur-Lyon, France, center of the former hair felt hat industry. Its permanent exhibition presents a chronological display of hats from 1850 on, and temporary shows

include the results from its biennial International Contest of Hat Designers, which in 2003 drew 176 hats from 16 countries, including Canada, the United States, Australia, and Japan.

See also **Beret; Hairstyles; Hats, Men's; Headdress; Turban; Veils.**

#### BIBLIOGRAPHY

- Bates, Christina. "Women's Hats and the Millinery Trade, 1840–1940: An Annotated Bibliography." *Dress* 27 (2000): 49–58.
- Clark, Fiona. *Hats*. The Costume Accessories Series. London: B. T. Batsford Ltd., 1982.
- Daché, Lilly. *Talking Through My Hats*. New York: Coward-McCann, 1946.
- deCourtais, Georgine. *Women's Headdress and Hairstyles in England from A.D. 600 to the Present Day*. London: B. T. Batsford, Ltd., 1973.
- Ginsburg, Madeleine. *The Hat: Trends and Traditions*. Hap-pauge, N.Y.: Barron's Educational Series, 1990.
- Langley, Susan. *Vintage Hats and Bonnets, 1770–1970*. Paducah, Ky.: Collector Books, 1998.
- McDowell, Colin. *Hats: Status, Style and Glamour*. New York: Rizzoli International, 1992.
- Reilly, Maureen, and Mary Beth Detrich. *Women's Hats of the Twentieth Century*. Atglen, Pa.: Schiffer Publishing, Ltd., 1997.
- Stein, Gail. "Mr. John, 'Emperor of Fashion,'" *Dress* 27 (2000): 37–48.
- White, Palmer. *Elsa Schiaparelli: Empress of Paris Fashion*. London: Aurum Press Ltd., 1986.
- Wilcox, R. Turner. *The Mode in Hats and Headdress, Including Hair Styles, Cosmetics and Jewelry*. New York: Charles Scribner's Sons, 1959.

*Beverly Chico*

**HAUTE COUTURE** Historically, aristocratic and upper-class women's fashionable Western dress was created by an intimate negotiation between the client and her dressmaker. The investment in the design was principally in the cost of the luxurious textile itself, not in its fabrication. The origins of the haute couture system were laid by the late seventeenth century as France became the European center for richly produced and innovative luxury silk textiles. Thus the preeminent position of France's luxury textile industry served as basis and direct link to the development of its haute couture system. The prestigious social and economic value of an identifiable couturier, or designer's name, is a development of the late nineteenth and early twentieth centuries.

Beginning in the mid-nineteenth century, the Paris-based haute couture created a unique fashion system that validated the couturier, a fashion designer, as an artist and established his or her "name" as an international authority for the design of luxurious, original clothing.

Couturiers were no longer merely skilled artisans, but creative artists with identifiable names printed or woven into a petersham waist tape that was sewn discreetly into the dress or bodice. This was the beginning of designer labels in fashion. The client was required to visit the couture house where a garment was made to measure to high-quality dressmaking and tailoring standards.

The couture house workrooms are carefully distributed according to sewing techniques. The sewing staff are divided between two areas: dressmaking (*fleur*), for dresses and draped garments based upon feminine dressmaking techniques, or tailoring (*tailleur*), for suits and coats utilizing male tailoring techniques of construction. The staff work according to a hierarchy of skills ranging from the *première*, head dressmaker or tailor, to apprentices. The selling areas, salons, are equally controlled and run by the *vendeuse*, saleswoman, who sells the designs to clients and negotiates the fabrication and fittings with the workrooms.

The British-trained tailor and dressmaker Charles Frederick Worth is commonly credited as being the "father" of haute couture. What was radical in the mid-nineteenth century was that a male was creating women's fashion, a situation that required intimacy between a dressmaker and client, and had previously been a female-dominated profession. Worth's designs also commanded high prices that were a substantial investment in the garment itself and his associated and recognizable design style. This significant shift established the profession of fashion designer of women's garments as a suitable and profitable one for men. Worth worked directly with the French silk weaving industry to access and promote the original, luxury textiles that were a signature of his production. His clientele included the nobility of European courts as well as the new haute bourgeois who followed his advice on appropriate dress for day to evening wear. Worth and his contemporaries, particularly Doucet, introduced innovations that have become standards for haute couture establishments. They created luxurious Paris salons to which wealthy clients came rather than the couturier visiting his patrons at their homes; they created artistic designs from which clients could select and that were made to measure; they also employed live mannequins who modeled the designs for private individuals. Thus the haute couture system of luxury dressmaking production was created.

In 1868, Worth instigated a new group called *La Chambre Syndicale de la confection et de la couture pour dames et fillettes*. This body, an outgrowth of the medieval guild system, was formed as a collective or type of union that could lobby and deal with issues related to labor, taxes, administration, and production for dressmakers. At this time there was little distinction between *couture*, clothing made to measure, and *confection*, ready-made clothing. In 1910, the two activities were clearly divided and the nomenclature *la haute couture* was strictly reserved for couture salons that produced collections for private clients,



not solely for professional buyers. The newly named *Chambre Syndicale de la haute couture parisienne* outlined specific rules for membership that evaluated the creativity of designs and the quality of fabrication that had to be made to measure for the client, and also instituted regulations concerning the sale of designs and reproductions. The issue of copying and design piracy was of constant concern to the haute couture industry that relied upon exclusivity to retain design supremacy and its resultant high prices. The creation of PAIS (*L'Association de protection des industries artistiques saisonnières*) in 1921 by Madeleine Vionnet aimed to protect individual haute couture designs. Designs were photographed on a mannequin, front, back and side, and these documentary design records were registered with PAIS, thereby intending to discourage piracy and could be used as evidence if required. Allegations of design piracy were dealt with under the French penal code. This service was later taken over by the *Chambre Syndicale* in 1943. By 1930, the *Chambre Syndicale* established a formal calendar of fashion shows that were coordinated, consecutive, not concurrent, and able to accommodate the increasing numbers of foreign buyers and journalists to the collections.

In 1929, the *Chambre Syndicale de la haute couture parisienne* established vocational sewing and design training in its associated schools under the Ministry of National Education. The school offered an apprenticeship of three years that began with practical sewing skills in the first year, garment construction techniques in the second, and women's tailoring and draping in the third year. Two more years were available to a select few thought capable of working as first hands within a couture salon and who could train heads of workrooms and potentially be creative designers. These schools and courses continue to operate in the early 2000s.

In 1939, there were seventy haute couture salons. However, World War II (1939–1945) and particularly the German Occupation of Paris, created a crisis in the industry. The Nazis wanted to move the Paris haute couture industry to Berlin or Vienna, but the president of the *Chambre Syndicale*, the couturier Lucien Lelong, successfully negotiated to keep it in operating in Paris. After the Liberation of Paris the haute couture industry needed to recapture the North American buyers and manufacturers in order to reinstate France's historical position as the center of fashion design and also in order to rebuild a fragile economy and industry. Even before the war, the principal client was no longer the private client, but the commercial buyer and the attendant fashion press, and this situation was heightened after the war. This was clearly reflected in the schedule of showings of the collections set by the *Chambre Syndicale* that showed to the North American commercial buyers, then the European buyers, and finally to private clients. Postwar recognition of the importance of the Paris haute couture for fashion design leadership was internationally recognized after 1947 with the acclaim of the new house of Christian Dior



### THE USE OF TOILE

A couturier's design was usually first created in inexpensive muslin, called a *toile*, so as to perfect the design, cut, and fit. These *toiles* record the exact cut and sewing techniques, and include samples of the interlinings, linings, and fabric required in the final garment. Paper patterns were also used to replicate designs.

(founded in 1945) by Carmel Snow in the American fashion magazine *Harper's Bazaar*.

In 1945, the *Chambre Syndicale* introduced more rigorous regulations intended to further control the quality and prestige of the haute couture industry in the difficult immediate postwar years. Haute couture was divided into two classes: *Couture*, and the more prestigious *Couture-Création*. An haute couture house had to apply for membership that was reviewed annually. The application made by a couturier for the classification *Couture-Création* covered several areas: at least twenty-five designs had to be created in-house, spring and fall, and made up on a live mannequin. The collection was then to be presented on live mannequins, and in an "appropriate" setting in the haute couture house located in Paris. The rules also covered the technical execution of the original models, the repetitions to be made in-house to clients' measurements, the number of fittings required and at what stage in the making, and the sales of the designs.

The 1950s were years of huge profits and press and the continuation and emergence of new haute couture salons. The most important, and largest, houses in terms of production were those of Christian Dior, Pierre Balmain, and Jacques Fath. The postwar years continued and consolidated the prewar situation that was shifting the economic basis of the houses from private sales to the commercial buyers. The large market for haute couture was as a design source. Couture was copied and adapted to limited editions, or line for line copies, a process that began in the 1930s, as well as for mass-market fashions. Haute couture houses sold the original models as well as *toiles* (muslins) and paper patterns, all of which was regulated by the *Chambre Syndicale*.

This situation stimulated many new initiatives from the Paris couture to control their designs and for the design houses to directly profit from them. Christian Dior began his own licensing arrangements with Christian Dior, New York, and Jacques Fath entered into the American ready-to-wear market with Joseph Halpert. Increasingly couturiers opened boutiques within their cou-



**Haute couture evening dress, circa 1894.** Dresses designed by the House of Worth, one of the first couture houses, were known for their luxurious textiles and were worn by wealthy society ladies. This Worth dress was worn by the wife of renowned architect Stanford White. © MUSEUM OF THE CITY OF NEW YORK. REPRODUCED BY PERMISSION.

ture salons in order to sell less expensive versions of their haute couture lines as well as accessories, a development begun by Paul Poiret in the early twentieth century. The society *Les Couturiers associés*, founded in 1950 by Jacques Fath, Robert Piguet, Jean-Marc Paquin, Marie-Louise Carven, and Jean Dessès, was a precursor to the creation of prêt-à-porter designed by couturiers who sold ready-made designs to French department stores. A similar initiative, *Le Prêt-à-porter Création* (1958–1962) was directly aimed at international buyers and press. It ceased as ready-to-wear collections by couture houses became firmly established. However, the successful governance of the *Chambre Syndicale* over the couture houses, and its huge success during the 1950s is reflected in prosperity of the haute couture that in 1959 exported garments worth 20 million francs, and 3,000 workers were employed on a full-time basis, totaling 100,000 hours per week for most of the year.

The Paris haute couture system was such a successful formula for attracting sales, prestigious clients, commercial buyers, and international press that all other couture organizations were based upon this French

model. In 1942, the Incorporated Society of London Fashion Designers was formed in England; in Spain during World War II the *Cooperativa de Alta Costura* was formed in Barcelona; the first Italian couture collective was shown in Florence in 1951; and the Association of Canadian Couturiers was founded in 1954. However, no other nation managed to create a haute couture industry that was as prestigious or economically important as Paris. The French system was historically based on its luxury textile industry and its ancillary industries of beading, embroidery, ribbons, and lace as well as its highly skilled artisans

The craft base of haute couture was financially difficult to maintain in an increasingly industrialized society. The numbers of couture house fell from 106 in 1946 to 19 by 1970. The establishment of quotas and high custom duties resulted in radical declines of haute couture exports and served to intensify the commercialization of rights for reproduction and licensing agreements. In 1953–1954, Pierre Cardin presented his first prêt-à-porter collection and made it a separate department within the house in 1963. In 1966, Yves Saint Laurent created Saint Laurent Rive Gauche, the first freestanding couture boutique. Sociocultural shifts and an emphasis on youthful fashion instead of designs for mature women caused the breakdown of uniformity in the women's wear market, and resulted in the haute couture's departure as the only or leading source for international fashion design. The more profitable ready-to-wear market necessitated new initiatives for the haute couture houses, which began to create new, less expensive non-couture lines marketed with labels associated with the prestige of the haute couture house.

The 1970s and 1980s were years of crisis and reconstruction for the haute couture, as the United States was no longer the primary market that it had been since the 1930s. In 1973 the *Chambre Syndicale de la couture parisienne* joined with the Prêt-à-porter federation, and became *La Fédération française de la couture, du prêt-à-porter des couturiers et des créateurs de mode*, and in 1975 joined with the *Fédération de l'union nationale des artisanale de la couture et des activités connexes*. In the early 2000s the organization has approximately 500 members and promotes French fashion at home and abroad. The consortium of French luxury products led by the group LVMH (Louis Vuitton Moët Hennessy) created by Bernard Arnault, bought out the leading names of the haute couture. In the early 1980s, Christian Lacroix renewed the 1930s house of Jean Patou, where he was artistic director from 1981 to 1987, and Parisienne haute couture was front-page fashion news as it had been in the 1950s and early 1960s. Karl Lagerfeld designed for Chloé and resuscitated the house of Chanel by cleverly employing all the Chanel hallmarks of design (logo, chains, cardigan suit jacket, loose tweeds, and so forth) and updating them for a younger market. The designer signature and logo became ubiquitous and familiar on an enormous range of products from fashion

to home furnishings. Once again haute couture was worn and promoted by international celebrities and equally famous and highly paid super models. In 1987, Arnault invested millions in the new haute couture house of Christian Lacroix, which had a similar impact on the revitalization and public interest in the haute couture industry that Marcel Boussac's investment in the opening of the house of Christian Dior had immediately after World War II in 1946. During the 1990s, LVMH purchased Dior, Lacroix, Givenchy, Celine, Kenzo in a restructuring aimed at reclaiming French fashion design leadership, which had been overtaken by Italian and Japanese high-end ready-to-wear fashions. Celebrity designers were selected to design the Paris haute collections. Claude Montana worked for the house of Jeanne Lanvin from 1990 to 1992, and young, radical, Brits John Galliano and Alexander McQueen designed for Givenchy. In 1996, Galliano was placed as the chief haute couture designer for the most prestigious house of Christian Dior as a replacement for Gianfranco Ferré. Few couture houses have kept their independence in an increasingly global and conglomerate economy. The houses of Pierre Cardin, André Courrèges, Patou, and Philippe Venet all ceased haute couture production, leaving only eighteen haute couture establishments by 1996. The 2002 retirement of Yves Saint Laurent closed one more establishment, but the new couture collection of Jean Paul Gaultier resulted from success as a ready-to-wear designer, a twenty-first-century inversion of the couture tradition.

In the early 2000s the business of haute couture is viewed as a costly and luxurious design laboratory that attests to and sustains France's international cultural position as a taste leader. Though haute couture posts enormous financial losses and produces less than 10 percent of the French clothing industry, the salons garner fantastic international press and prestige for the house name, which fuels lucrative licensing agreements for ready-to-wear collections, perfumes, accessories, and domestic products.

See also **Balmain, Pierre; Cardin, Pierre; Courrèges, André; Dior, Christian; Doucet, Jacques; Lagerfeld, Karl; McQueen, Alexander; Patou, Jean; Worth, Charles Frederick.**

#### BIBLIOGRAPHY

- Antoine-Dariaux, Geneviève. *Elegance: A Complete Guide for Every Woman Who Wants to Be Well and Properly Dressed on All Occasions*. Garden City, N.Y.: Doubleday, 1964.
- Dior, Christian. *Dior by Dior*. Translated by Antonia Fraser. London: Weidenfeld and Nicolson, 1957.
- Fraser-Cavassoni, Natasha, and Jennifer Jackson Alfano. "Couture's Big Spenders." *Harper's Bazaar*, October 2002, pp. 88ff.
- Grumbach, Didier. *Histoires de la Mode*. Paris: Seuil, 1993.
- Lynam, Ruth, ed. *Couture: An Illustrated History of the Great Paris Designers and Their Creations*. New York: Doubleday, 1972.

- Palmer, Alexandra. *Couture and Commerce: The Transatlantic Fashion Trade in the 1950s*. Vancouver: University of British Columbia Press, 2001.
- Picken, Mary Brooks. *Dressmakers of France: The Who, Why and How of French Couture*. New York: Harper and Brothers, 1956.
- Steele, Valerie. *Paris Fashion: A Cultural History*. New York and Oxford: Oxford University Press, 1988.
- Troy, Nancy J. *Couture Culture: A Study in Modern Art and Fashion*. Cambridge, Mass.: MIT Press, 2003.
- Veillon, Dominique. *La mode sous L'Occupation: Débrouillardise et coquetteries dans la France en guerre (1939–1945)*. Paris: Payot, 1990.

Alexandra Palmer

**HAWAIIAN SHIRT** Hawaii's aloha shirt has become a visible manifestation of the state's multicultural population, and in Hawaii, wearing these shirts represents both an attitude and Hawaiian identity. The style lines and design motifs of the aloha shirt developed from the interaction of several of Hawaii's immigrant groups. The aloha shirt took its shape from the shirts worn by the first Caucasian men to appear in the islands—British and American sailors. In addition, the looseness of the shirts worn by Filipino men, the *barong tagalong*, was incorporated as a key element of the aloha shirt as an adaptation to Hawaii's tropical environment. The early aloha shirts (1920s–1930s) were made of Japanese kimono fabric by Chinese tailors, and the early customers were *haole* (Caucasian) residents and tourists, or *hapa haole* (part Caucasian) residents of Hawaii. It was not until World War II that the local population embraced the wearing of aloha shirts.

The early aloha shirts were made of silks and kabe crepe, with Asian design motifs. Ellery Chun trademarked the aloha shirt in 1935, and from that time on designs took on a tropical Hawaiian theme for quite some time. Rayon of good quality was not available until the early 1940s. When it was adopted for use, vibrant colors and designs were the result and these shirts were called "silbies" due to the feel of the fabric. Silbies are the most highly collectible of the aloha shirts, and were produced until the mid 1950s when they went out of style. The 1950s featured abstract designs and cotton fabrics, and in the 1960s the reverse-print aloha shirt was created to look like faded shirts worn by surfers. While tourists ignored these shirts, locals immediately adopted them as a badge of Hawaiianess. Synthetic fabrics with ethnic designs became popular in the 1970s aloha shirts. Tropical designs of flora and fauna have consistently been featured, and the 1990s favored retro styles in rayon and silk. Manufacturers have brought back some of the original designs of the famous "silbies" of the 1940s and 1950s.

The aloha shirt has had an impact on American business attire. The production of reverse-print shirts worn for work by most men in Hawaii have kept pace with more vibrant shirts that are worn for more casual occasions.



Hawaii's aloha shirt began America's movement toward business casual attire in 1962 when Hawaii's government required men to wear it throughout the summer, and then later on, Aloha Friday was declared, and workers were (and still are in the early 2000s) expected to dress in aloha attire every Friday. One could say that Aloha Fridays led to Casual Fridays on the U.S. mainland. Throughout the mid-twentieth century, tourists and soldiers brought the aloha shirt to the U.S. mainland but more importantly, the aloha shirt migrated to California on the backs of surfers who brought the relaxed shirt and lifestyle to the mainland. This was the beginning of the business casual movement, as many of the young California surfers grew up to become Silicon Valley executives who shed three-piece suits for more relaxed attire at work and instituted Casual Fridays into the world of business.

See also **Colonialism and Imperialism; Cotton; Rayon.**

#### BIBLIOGRAPHY

- Arthur, Linda. *Aloha Attire: Hawaiian Dress in the Twentieth Century*. Atglen, Pa.: Schiffer Publications, 2000.
- Brown, David, and Linda Arthur. *The Art of the Aloha Shirt*. Honolulu, Hawaii: Island Heritage, 2002.
- Hope, Dale, and Gregory Tozian. *The Aloha Shirt*. Hillsboro, Ore.: Beyond Words Publishing, 2000.

Linda B. Arthur

**HAWES, ELIZABETH** Elizabeth Hawes (1901–1971) belonged to the first generation of American designers who succeeded in making a name for themselves as individuals outside the sphere of the Parisian couture. In 1925 Hawes graduated from Vassar College, where she was an economics major sympathetic to socialism, but she pursued an interest in fashion by participating in school theatricals and making her own clothes. By graduation she had decided to go to Paris and learn fashion design. Hawes spent the next three years in various positions within the couture business: as a design copyist, journalist, and assistant designer. During this time she wrote a fashion column for *The New Yorker*, using the pen name “Parisite.” She also worked briefly for Nicole Grout, the sister of the designer Paul Poiret. Her life in Paris was divided between socializing with her wealthy Vassar friends and engaging in the bohemian life; she spent much of her time with an artistic crowd, including the sculptors Alexander Calder and Isamo Noguchi.

Hawes's Vassar education gave her the critical faculty to dissect the couture industry and the fashion press, while her social connections and her exposure to couture at the highest levels left her ambivalent about fashion, a feeling that grew all the stronger for her love of its creative potential. In 1928 Hawes returned to New York and started her own custom dressmaking business with a Vassar classmate, Rosemary Harden. Harden left the busi-

ness one year later, and Hawes decided to continue on her own as Hawes, Inc. Advertising, for which Hawes herself wrote the copy, helped business pick up significantly. Calder and Noguchi designed decorative objects for her New York showroom and influenced Hawes's own work. In 1930 Hawes married the artist Ralph Jester, whom she had known in Paris; they divorced in 1934.

#### Fashion and Politics

In 1932 Hawes and two other young American designers were promoted by the Lord and Taylor department store. This was one of the earliest attempts (if not the first) to prove that there was homegrown talent worthy of the public's notice. Hawes fully understood the power of publicity and exploited it. The ensembles in her collections were named according to themes: Spring/Summer 1933 was political, and the collection included such ensembles as “The Five Year Plan,” a cotton nightgown and bed jacket; “the Yellow Peril,” a silk afternoon dress; and “Disarmament,” an embroidered evening dress. Her work was characterized by a bold use of fabrics—wide strips and large prints were used in simple, comfortable silhouettes. Hawes was an early advocate of trousers for women and wore them often herself.

In 1935 Hawes traveled to the Soviet Union to explore her growing interest in mass-produced clothing; as part of this trip, she showed some of her designs to members of the Soviet State Clothing Production Board, known as the Soviet Dress Trust. During her trip to the Soviet Union, she was accompanied by the theatrical director Joseph Losey, whom she married in 1937. The next year brought the birth of their son, Gavrick, and the publication of her first major work as an author: *Fashion Is Spinach*. This was Hawes's manifesto, and in it she expounds on the difference between “style” and “fashion” and how women are manipulated by the fashion industry:

Style . . . gives you the fundamental feeling of a certain period in history. Style doesn't change every month or every year. . . . Fashion is that horrid little man with an evil eye who tells you that last winter's coat may be in perfect physical condition, but you can't wear it. (pp. 5–6)

Hawes's criticism was not limited to women's clothing; she maintained that men needed to be freed from their conservative attitudes toward clothing. She staged an all-male fashion show in 1937, showing brightly colored clothes of her own design. This led to her next book, *Men Can Take It*, published in 1939. She could be considered the Dorothy Parker of fashion criticism, with her snappy tone and tell-it-straight attitude.

#### Career Change

Hawes, Inc., closed early in January 1940. The onset of World War II had firmly awakened Hawes's social conscience, and she felt that being a fashion designer was not an appropriate career for her at that time. She became committed to her career as a writer, becoming involved

in writing for the new left-wing paper, *PM*. In 1943 she took a job in a munitions factory for three months and then relocated to Detroit to work for the United Auto Worker's Union, where she also wrote for the *Detroit Free Press*. The result of her war work was her fifth book, *Why Women Cry; or, Wenches with Wrenches* (1943).

In 1948 Hawes made a last attempt at the fashion business and reopened Hawes, Inc., for eleven months. To demonstrate the timelessness of her designs, she played a game at the inaugural show, making guests guess which designs were new and which were from 1930s collections. Hawes settled in Southern California in the early 1950s. While she experimented with the production of knitwear, creating simple shapes decorated with abstract patterns, she spent the majority of her time writing. Her most rewarding experience during this period was her association with the young designer Rudi Gernrieche, in whom she found a kindred spirit. In 1967 a retrospective of their work was mounted at the Fashion Institute of Technology.

Hawes moved back to New York in 1967 and lived in the Chelsea Hotel until her death on 6 September 1971. In total, she published nine books on fashion and culture as well as numerous articles in journals ranging from the left-leaning *PM* to the *Ladies' Home Journal*. In reality, her clothes did not appear radical for their time; it was her outspoken philosophy that set her apart.

See also **Fashion Designer; Fashion Journalism; Paris Fashion; Politics and Fashion.**

#### BIBLIOGRAPHY

- Berch, Bettina. *Radical by Design: The Life and Style of Elizabeth Hawes*. New York: E. P. Dutton, 1988.
- Hawes, Elizabeth. "The American Designer Has Not Yet Been Born." *Magazine of Art* April 1937.
- . *Fashion Is Spinach*. New York: Random House, 1938.
- Mahoney, Patrick. "In and Out of Style." *Vassar Quarterly* 82, no. 2 (Spring 1986): 8–10.
- Steele, Valerie. *Women of Fashion: Twentieth-Century Designers*. New York: Rizzoli International, 1991.

Melinda Watt

**HEAD, EDITH** Edith Head (1897–1981) was born in San Bernardino, California. In 1923, after a brief career as a schoolteacher, Head answered an advertisement for a sketch artist at Famous Players–Lasky (soon to be renamed Paramount Studios). Although she had very little artistic training, her versatility impressed Howard Greer, the chief costume designer, who hired her immediately. When Greer left Paramount in 1927, he was replaced by his assistant designer, Travis Banton. As chief designer, Banton costumed the stars at Paramount, while Head, who had been promoted to assistant designer, costumed the B-movie players and extras. When Banton left the studio in 1938, Paramount named Edith Head chief de-



**Edith Head tailors a dress for Sophia Loren.** Head was well known for her ability to work with difficult personalities and to camouflage figure problems. © BETTMANN/CORBIS. REPRODUCED BY PERMISSION.

signer; she remained at the studio in this capacity until 1967. That same year she received a contract with Universal Studios, where she worked until her death in 1981. From the 1950s on, Head became a media personality through her regular appearances on the television show *Art Linkletter's House Party*. She also published two books: *The Dress Doctor* (1959) and *How to Dress for Success* (1967).

During her fifty-eight-year career, Head received more than one thousand screen credits, garnered thirty-five Oscar nominations, and won the Academy Award for costume design an unprecedented eight times. She was legendary for her ability to please difficult personalities and to camouflage figure problems. She was considered particularly skilled at defining character through costume, and her "character" costumes were among her most successful, including those for *Double Indemnity* (1944), *The Heiress* (1949), and *Sunset Boulevard* (1950). Head was especially proud of her work on *The Heiress*, for which she had traveled to the Brooklyn Museum of Art to conduct period research, winning her the first of her many Academy Awards. Her collaborations with the director Alfred Hitchcock were renowned, since Head shrewdly understood the importance of costume to Hitchcock's creative vision in his films *Rear Window* (1954), *To Catch a Thief* (1955), and *Vertigo* (1958).

## HEADRESS

Head's designs were also occasionally responsible for influencing popular fashions. Her costumes for the Mae West film *She Done Him Wrong* (1933) reputedly set off a flurry of Gay Nineties-inspired fashions, while the sarong worn by Dorothy Lamour in the film *The Jungle Princess* (1936) continued to influence styles well into the next decade. Her costumes for Barbara Stanwyck in *The Lady Eve* (1941), which featured bare midriffs and fringed bolero jackets, are said to have popularized Latin American styles. Her most influential design by far was the lilac-strewn gown worn by Elizabeth Taylor in *A Place in the Sun* (1951). The dress was a sensation in the teen market, and thousands of copies were sold.

Throughout her career, Head was criticized for taking credit for costumes she did not design and for exaggerating her influence on popular fashion. Despite these flaws, Head was undeniably one of the hardest-working talents in costume design and certainly one of the most versatile. Her intelligence and dedication secured her position both in the Hollywood studio system and in the history of fashion.

See also **Costume Designer; Film and Fashion.**

### BIBLIOGRAPHY

- Chierichetti, David. *Edith Head: The Life and Times of Hollywood's Celebrated Costume Designer*. New York: HarperCollins Publishers, Inc., 2003.
- Epstein, Beryl Williams. "Edith Head." In *Fashion Is Our Business*. Philadelphia: J. B. Lippincott, 1945.
- Head, Edith, and Jane Kesner Ardmore. *The Dress Doctor*. Boston: Little, Brown and Company, 1959.
- Head, Edith, with Joe Hyams. *How to Dress for Success*. New York: Random House, 1967.
- LaVine, W. Robert. *In a Glamorous Fashion: The Fabulous Years of Hollywood Costume Design*. New York: Charles Scribner's Sons, 1980.

Clare Sauro

**HEADRESS** Headdress is an elaborate, ornamental, or practical covering for the head, as differentiated from the hat, which has a crown, and includes many varieties such as the hairnet, headband, head wrap, wreath or chapel, mantilla, turban, crown, and others. Headdresses incorporate complex meanings including religious symbolism, political power and affiliation, social status or rank, and fashion consciousness. Made of numerous materials, designs, shapes, and embellishments, headdresses can also serve practical purposes—protecting the head against natural elements, carrying objects like weapons, baskets, or water pots—and are often associated with ceremonies, particularly rites of passage.

### Hairnets

Hairnets may be the oldest headdresses worn by humans. A mammoth-ivory figurine dated circa 36,000 B.C.E. and

found at Brassempouy (Las Landes), France, shows a human face with hair possibly braided and covered with what appears to be a netting. Bronze Age second millennium B.C.E. hairnets of horsehair using the sprang or twisted-thread technique were found in Borum Eshøj, Denmark, and are preserved in the National Museum, Copenhagen. Complementing long, unfitted robes, a fashionable silk hairnet, known as a crespine, was worn with head and chin bands by upper-class women during the late thirteenth century C.E. in medieval Europe. By the 1500s, as Renaissance styles spread from Italy to northern Europe, ornate gold cord mesh, pearl-studded nets called cauls became fashionable. A modern version of the Renaissance-style silk-knobbed hairnet, Goyesca, which cascades down to a tassel is still worn at Spanish festivals. It commemorates Francisco Goya (1746–1828) who painted celebrating peasants of both sexes wearing tasseled hairnets. By the 1920s, new cropped and wavy hairstyles on European and American women led to the mass production and marketing of fine human hairnets, particularly for outdoor wear. Within a few years, international designers such as Elsa Schiaparelli (1930s) and Sally Victor (1940s) popularized the "snood" style hairnet, often made of chenille, cord, or ribbon and attached to a hat.

### Headband Bandeau

Modern headbands, originally made of knitted wool, cotton, and later of natural and synthetic fiber mixtures, have many functions besides holding the hair in place. Athletes such as marathon runners, skiers, basketball, and tennis players wear them across the forehead to absorb perspiration. Political advocates use them like earlier hatbands to make public statements. In 1893, native Hawaiians in Western clothing appeared on Honolulu streets wearing hatbands with the words Aloha Aina ("Love of Country") indicating their loyalty to Queen Liliuokalani and opposing U.S. annexation. World War II Japanese kamikaze pilots wore white samurai headbands (hachimake), with a red rising-sun emblem and the words "Absolute Victory" in black Japanese calligraphy, while participating in rituals before flying off on suicide missions against U.S. targets; and in 2003, exiled protesters demonstrating against their country's ruling military dictatorship wore red headbands with white stars, symbolizing the Burmese peoples, outside Burma's Embassy in Bangkok, Thailand.

Aesthetically, headbands are part of many ethnic costumes. On the Indonesian islands of Bali and Sulawesi, men wear cotton batik headbands (formed from a folded square of cloth) for everyday, ornamented brocades for festivals. Reflecting social rank, lace-edged cotton headbands were part of a maid's uniform in Europe and America, representing nineteenth- and twentieth-century middle-class gentrification, a carryover from earlier aristocratic livery customs.

Metal headbands worn across the top of the head hold earmuffs in place. Over centuries, in cold climates,



earflaps on fur hats could be tied over the head or let down as desired. By the early twentieth century, with outdoor recreational sports gaining popularity, mass-produced metal-headband fur earmuffs came to be marketed for adults and children. The industrial revolution had another impact on ear protection, namely, against noise. By the 1920s, pilots flew open-cockpit planes wearing cloth “helmet” caps designed with inner pockets over the ears to hold noise-absorbent material. More recently, responding to concerns for worker safety, industrial earmuffs were introduced for preventing hearing loss caused by loud machinery noises. In the early 2000s, there are noise-reduction, liquid-foam filled cushioned earmuffs, cap-mounted earmuffs, a Velcro-adjustable type, and three-position version (over-the-head, behind-the-head, and under-the-chin). Most contemporary flight or fire-fighting helmets are additionally equipped with wired earmuffs allowing communication between the wearer and coworkers. Cyclers, hunters, and other sports enthusiasts can enjoy musical CDs, tapes, and radio broadcasts through ear covers, computer designed for lightweight comfort, portability, and noise attenuation.

### Kerchief and Head Wrap

The kerchief, a cloth covering the head, from the French *couvrir* (to cover) and chief (head), is usually worn by women. Traditionally, European peasants wore a small cloth tied under the chin while working outside; thus, the kerchief became associated with rural women and later with lower-class city residents. As late as the 1950s, a domestic servant girl in Madrid, Spain, was considered breaking social barriers by wearing a hat rather than the kerchief assigned her class. Also called a bandanna, the kerchief did become a practical middle-class head cover used for riding in open automobiles.

The head wrap, a kerchief worn by tying over the forehead, is believed to have traveled with women from Senegal and Gambia (West Africa) along the slave trade routes to Caribbean Islands and ports in North and South America. The falla, a strip of cotton cloth tied around the head in eighteenth-century Gambia, may be the precursor to the head wrap later identified with adult female slaves. Imported into New Orleans possibly by way of the French colonies Martinique and St. Dominique, the head wrap when worn by free women of color, became a nineteenth-century fashion called Tignon, created from brightly-colored madras, occasionally adorned with jewels and feathers.

### Spanish Mantilla

Usually black or white, the mantilla may derive from *manton* (mantle or cape) worn both indoors and outdoors during the Muslim rule of Spain. Mantillas (small capes) were originally head coverings of handmade silk lace, often imported from Chantilly, France, and worn by aristocratic women, as documented in portraits by Velasquez (c. 1625) and Goya (1792). By the nineteenth century, a



**Yemenite bride in wedding finery.** Headdresses are part of the costume for special occasions in many cultures, such as this elaborately crafted bridal hood. © RICHARD T. NOWITZ/CORBIS. REPRODUCED BY PERMISSION.

popular hairstyle, the chignon, provided suitable positioning for high, decorative combs (tortoiseshell, silver, ivory) to support larger mantillas—some measuring 7 x 3 feet—which drape over the shoulders. This style is commonly worn for special events such as Holy Week processions and community fiestas. Red-silk knobbed mantillas are occasionally worn by unmarried young women to bullfights. Romantic myths transported to Spanish colonies in Latin America (Mexico) and the Philippines depict señoritas in white mantillas on balconies listening to guitar-playing suitors. Because of their cost, mantillas are often passed down from mother to daughter as family heirlooms. The lace mantilla, without a comb, was a French fashion during the 1920s and 1930s.

### Royal Headdresses

Since antiquity, rulers have worn impressive and costly headdresses, visible symbols of their power and claims to divinity. Prehistoric peoples stressed survival; their practical head coverings were made of animal skins in northern



**Masai woman with traditional headdress and jewelry.** Headdresses have many styles, including the headband, hairnet, headwrap, mantilla, and turban. They can serve various practical purposes, but also connote religious symbolism, political power, and social status. © YANN ARTHUS-BERTRAND/CORBIS. REPRODUCED BY PERMISSION.

regions, twisted straws in warm climes. With the evolution of complex population centers, textile production and class stratification emerged in Mesopotamia, which resulted in Sumerian turbans and head wraps (3000 B.C.E.), and later splendid regal twisted hair and headbands during the Akkadian era (2250 B.C.E.). Egyptian royal ceremonial headdresses of the New Kingdom (c. 1580–1085 B.C.E.) were extremely precious, some made of gold decorated with inlaid carnelian, colored glass, and ostrich feathers.

The Ancient Greek *korone* (crown), a golden circlet or gold wreath, symbolized political and military power during the fourth century B.C.E. Macedonian era, while Olympic champions were crowned with nature cult headpieces: laurel, olive, pine, or celery wreaths. Adopting Greek depictions of gods, especially Apollo, many Roman emperors were portrayed on coins wearing the laurel wreath. Christian monarchs since Charlemagne have worn bejeweled crowns with a cross symbolizing their power as God-given.

Gigantic turbans, three to four times the head size, usually wrapped around a tall hat, adorned the heads of Ottoman sultans including Süleyman I in early sixteenth-century Istanbul. For public occasions, Manchu royalty in China wore ornate cone-shaped, silk-covered headpieces, with imperial insignia above a tall gold finial intricately decorated with dragons, Buddhas, and pearls. But the nonofficial headdress worn by the Empress

Dowager Cixi and her courtiers (1903) was more striking. Bat-wing shapes of false hair and black satin were arranged over a wide frame with large artificial flowers and long silk tassels dangling from the sides.

For centuries, Japanese emperors have worn the black lacquered ceremonial headpiece (*kanmuri*) with a birdlike tail made of fine horsehair, associated with Shinto priests and courtiers. Because of his role as intermediary between humans and gods, only the emperor wore the tail vertically.

Glass beads, cowrie shells, and feathers are the precious materials used for elaborate headdresses of many African chieftains. A Yoruba king in Nigeria, who represents the collective destiny of his people, wears a tall conical beaded headdress asserting his authority in social, political, and religious matters. Numerous strands of beads hang from the royal headdress hiding his face, which is considered powerful and dangerous. The headdress, which represents the king, must be given reverence in his absence.

A 46-inch-high Aztec headdress (*kopilli ketzalli*), popularly called “Montezuma’s Crown” and adorned with over 400 Quetzal bird feathers, is exhibited at Vienna’s Hofburg Museum of Ethnology in the early 2000s. For Aztecs, the number 400 represented eternity; only the highest-ranking ruler could wear 400 feathers of this sacred bird, associated with wisdom, peace, and freedom. The headdress supposedly was taken by Spanish invaders under Cortez and sent in 1524 as a present to Hapsburg ruler Charles V, then Holy Roman Emperor and king of Spain. Since the early 1990s, Yankuikanahuak, an association fostering revival of native Indian cultures supported by the Mexican government, has been lobbying the United Nations and the Austrian government to return this sacred relic to its rightful homeland. Similar efforts have taken place in the United States. Under the Native American Graves Protection and Repatriation Act, an eight-foot-long war bonnet, made of thirty-five sacred bald and golden eagle feathers each measuring one foot, and claimed to have belonged to the renowned nineteenth-century Apache Chief Geronimo, came under government protection for return to tribal ownership.

### Wedding Headdresses

In many cultures and religious traditions, elaborate wedding headdresses become ritual objects. The Mien mountain tribal peoples of Laos and Thailand in the Golden Triangle emphasize a complex structure on the bride’s head. Her hair, coated with beeswax, is pulled through a tube projecting from a large board on her head above which a vault (like a roof truss) is created from bamboo sticks. A red-embroidered patterned fabric covers the whole ensemble. After two days of ceremonies, the headdress is removed indicating the bride’s acceptance as a full member of the groom’s household.

For festivals, including weddings, Hmong (Miao) women in China’s Yunnan Province wear an elaborate

black scarf measuring to 35 feet long that is wrapped around the head creating a plate shape. The headdress features an embroidered belt with dangling tassels or coins around its edge. Decorations include amuletic symbols: a spiral motif representing family; triangular patterns as “sacred mountains” protecting against evil spirits.

Traditional Japanese brides wear an elaborate hairstyle called Bunkin-Shimada. Hair decorations include a comb (*kushi*) and gold or silver multithreaded string folded in back in an elaborate shape. Hand-painted, lacquered floral-motif hairpins (*kanzashi*) may depict good-luck symbols such as pine trees for durability. Matching comb-and-hairpin sets are sold or rented in bridal stores. A white brocade band or hood (*tsuno-kakushi*), matching a white kimono, covers the elaborate bridal-adorned coiffure. White symbolizes the bride’s willingness to “color herself as the husband wishes.” The term “tsuno-kakushi” combines the words for “horn” and “concealer.” It is said the white hood hides horns of jealousy or hatred the wife might have toward her husband, in-laws, or neighbors. At ceremony’s end, the bride removes the white head-dress signifying she has left her family and adopted his.

In imitation of Ming empress crowns, Chinese brides wear an ornate phoenix headdress made of tiny gilded silver butterflies, flowers, and fruits dangling from wires, with inlaid kingfisher feathers (fertility and good-luck symbols) and embellished with strings of pearls hiding the bride’s face. A large red veil completely covers the bride’s head. Symbolism of the phoenix headdress and dragon motif on her robe associates the couple with the royal family, suggesting they are “emperor and empress” for the day.

Jewish wedding headgear incorporates local ethnic variations. One ornate example is the Yemenite bridal gargush, or hood, with its elaborate metallic ornamentation. Everyday gargushes are black cotton or velvet with a band of jewelry pendants (*agrat*), tiny silver rings, discs, and balls dangling over the forehead. Costly bridal gargushes are crafted from gold brocade decorated with golden agrats, golden chains (*kbneisbe*, *salsa*), valuable coins, and fine filigree pins (*koubleh*) of geometric shapes.

Crowns, wreaths, and veils are wedding head wear popularly used for Christian rituals. In Russian Orthodox ceremonies, ornate royal-style crowns with Christ and the Virgin icons are held over the bride and groom’s heads. The couple is recognized as ruling a new kingdom, the home, where they are urged to live together as moral Christians.

Throughout Europe, peasants held spring flower festivals (Christian substitutes for earlier pagan fertility rites) and some groups adopted them for wedding celebrations. The white lace veil with orange blossom wreath became a classic after Queen Victoria’s attire worn at her 1840 wedding to Prince Albert.

In the twenty-first century, Greek Orthodox couples wear wreaths of real, fabric, or artificial flowers joined to-

gether by a long ribbon representing their marital union. A similar practice of combining wedding headpieces is used by Buddhist couples in Thailand, where round white “Circles of Eternity” are joined by long strings.

See also **Crowns and Tiaras; Hats, Men’s; Hats, Women’s; Helmet; Turban; Veils.**

#### BIBLIOGRAPHY

- Arnoldi, Mary Jo, and Christine Mullen Kreamer. *Crowning Achievements: African Arts of Dressing the Head*. Los Angeles: Fowler Museum of Cultural History, University of California, 1995.
- Biebuyck, Daniel P., and Nelly Van den Abbeele. *The Power of Headdresses*. Brussels, Belgium: Tendi, 1984.
- Boucher, François. *20,000 Years of Fashion: A History of Costume and Personal Adornment*. New York: Harry N. Abrams, 1967.
- Cocuzza, Dominique. “The Dress of Free Women of Color in New Orleans, 1780-1840.” *Dress* 27, (2000): 78–87.
- Foster, Helen Bradley. *New Raiments of Self and African American: Clothing in the Antebellum South*. Oxford and New York: Berg, 1997.
- Garrett, Valery M. *Chinese Clothing, an Illustrated Guide*. Hong Kong: Oxford University Press, 1994.
- Kilgour, Ruth Edwards. *A Pageant of Hats, Ancient and Modern*. New York: Robert M. McBride, 1958.
- Lewis, Paul and Elaine. *Peoples of the Golden Triangle*. London: Thames and Hudson, Inc., 1984.
- Rubens, Alfred. *A History of Jewish Costume*. New York: Crown Publishers, 1973.
- Wilcox, R. Turner. *The Mode in Hats and Headdress*. New York: Charles Scribner’s Sons, 1959.

Beverly Chico

**HELMET** A helmet—a defensive covering for the head—is made of hard materials for resisting blows so as to protect ears, neck, eyes, and face. Helmets have been worn over centuries for military combat and ceremonies, later for hazardous occupations, and recently for sports. Helmet design fluctuated with changes in warfare and technology.

#### Ancient Helmets

Prehistoric peoples probably wore woven basketry or hide head protectors; ancient Ethiopians used horse skulls, manes, and tails. Archaeological evidence reveals that rawhide caps and copper helmets, protecting ears and neck nape—with chin straps and padded wool or leather lining—were worn by Sumerian, Babylonian, and Assyrian warriors during the third to first millennia B.C.E. Early Greek helmets were usually bronze hemispherical crowns. The Corinthian version incorporated a movable face mask; the Attic style had cheek guards (mentioned by Homer). Romans used Greek designs, including elaborate horsetail plumes; crested gladiator helmets were made of hammered bronze.



HELMET

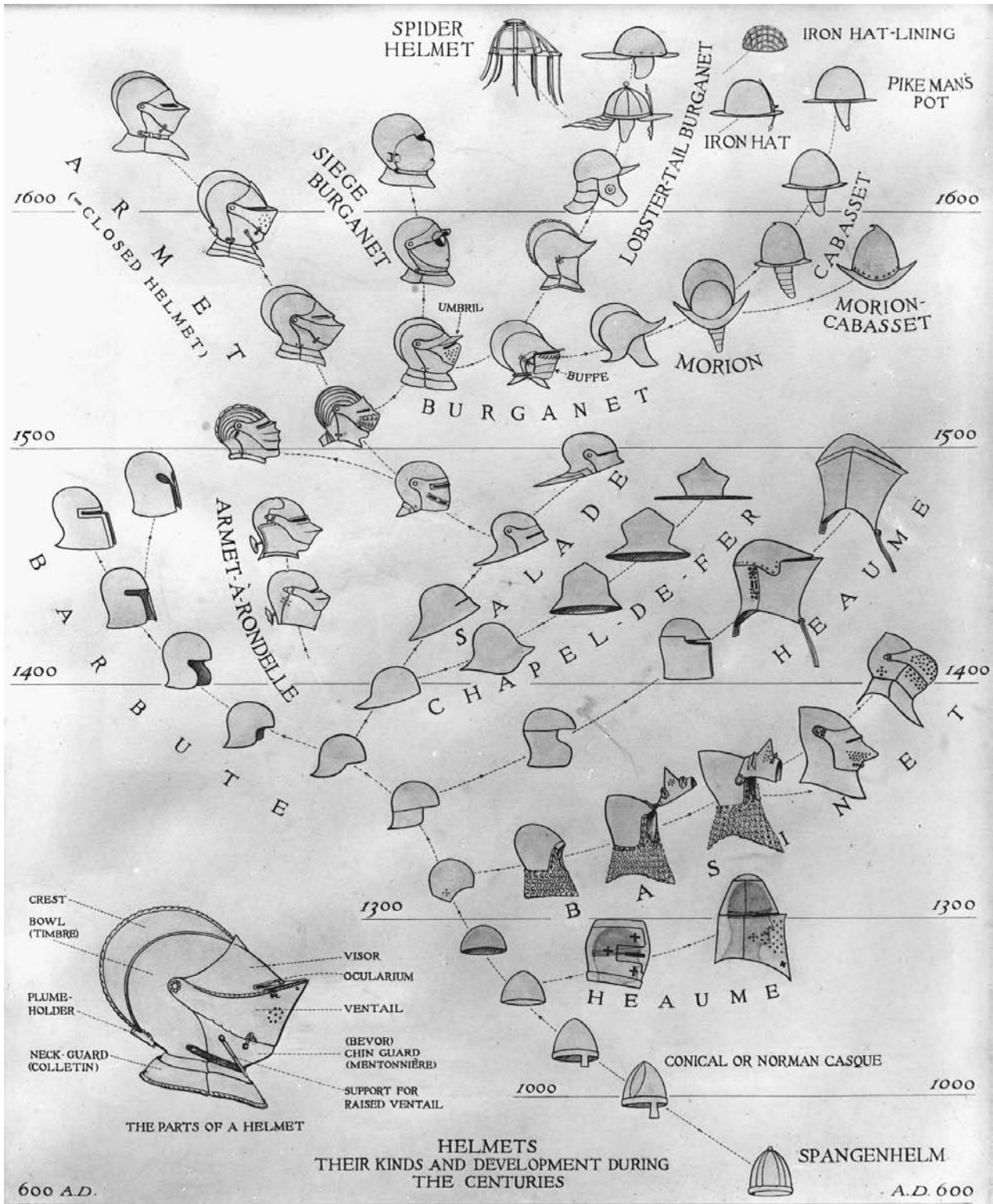

**Evolution of European medieval helmets.** Over the course of the Middle Ages, armored helmets became lighter and more flexible to adapt to different styles of warfare. THE METROPOLITAN MUSEUM OF ART. REPRODUCED BY PERMISSION.

### Middle Ages

European medieval helmets evolved from the seventh to seventeenth centuries as part of body armor, beginning with a boiled leather conical casque (*spangenhelm*) worn by tribal warriors over a hood of mail. During the feudal era, a large, heavy iron pot (*heaume*) protected the head from lances in chivalry tournaments, and the towering steel snouted visor (*basinet*) was worn in battle. Archers and pikemen used lighter, more flexible helmets with neck guards during the Hundred Years' War (c. 1337–1453).

By 1550, the Italian-invented *armet*, with its thin laminated iron or steel plates and joints providing ease of movement, was adopted by many armies in Europe. The crescent-shaped morion, copied from Moorish designs, protected sixteenth-century Spanish conquistadores in the New World against Indian bows and arrows.

Armor and helmet production reached its artistic zenith for knights and nobles during the sixteenth and seventeenth centuries; ornamental parade pieces often had embossed relief decorations reflecting Renaissance-style, Biblical, and mythological motifs, along with ostrich or peacock panaches. By the eighteenth and nineteenth centuries, when the ultimate weapon was a cannon, metal helmets were displaced by lighter, felt tricorne hats, lamb's fur busbys, and beaver-with-leather shakos.

Another head protector came into widespread use after the 1850s mutinies in Bengal, India, where British troops encountered light, strong helmets made from the dried pith of the solah or sponge wood plant. Subsequently, the "pith sun helmet" was adopted by England and other countries for overseas military campaigns and sports.

### Modern Military

World War I technologically revolutionized warfare and weaponry. Shallow-crowned, felt-padded steel helmets protected combatants in trenches against automatic machine guns, replacing earlier spiked and plumed headgear. M-1 steel helmets of World War II infantry were more comfortable with an internal sweatband liner that rested lightly on the soldier's head. Serving multiple functions for the troops, helmets were used as washbasins, eating bowls, and cooking pans. Throughout the twentieth century, at military funerals, a soldier's helmet often sits atop a rifle symbolizing personal heroism and patriotism.

From 1970 to 1997, the U.S. Army Natick Research, Development, and Engineering Center in Massachusetts developed the standard Personnel Armor System Ground Troops (PASGT) helmet; its shell is a one-piece composite molded structure made of multiple levels of Kevlar aramid fiber. Inside is a cradle-type suspension providing space between the helmet and head for ventilation and deformation during impact. Cotton and nylon twill camouflage reversible covers reflect different environments: woodlands, snow, and daylight desert.

Continuing innovation, the twenty-first-century U.S. Army incorporates the most advanced high-tech fea-

tures in its standard bulletproof Integrated Helmet Assembly Subsystem (IHAS). Its attachments, including night-vision goggles, allow for viewing the battlefield via digitized maps, messages, and sensor imagery generated from a personal computer and weapon sights, while receiving audio communications through a computer/radio subsystem composed of components embedded into the ballistic helmet shell. Defensively, the headgear also includes a chemical/biological protection mask and ballistic/laser eye protection.

### Occupation Helmets

With nineteenth-century urban growth, larger police and fire units wearing military-style uniforms and helmets including chin straps, badges, and spikes encouraged esprit de corps. In 1863, London's Metropolitan Police began wearing the high-crowned dark serge-covered cork helmet (called "bobby hat" after the Tory prime minister Robert Peel, founder of the Metropolitan Police), similar to the lightweight pith helmet. Around 1900, a more practical, modern peaked hat was adopted in many countries, complemented decades later by titanium or plastic helmets with transparent anti-riot shields. Despite the changes, the English bobby hat survived.

Parisian fire brigades in the 1830s were outfitted with metal, gendarmerie cavalry visor casques. Wide-brimmed leather fire helmets, which (unlike metal) resisted retaining heat, were first used in New York (1740s) and spread to many areas over the next century. By 1959, U.S. government safety regulations began requiring the use of polycarbonate-plastic helmets that are impact, penetration, and water resistant, insulated against electrical charges, and self-extinguishing. Fire helmets of 2004 have transparent plastic face masks.

Coal and ore mining, which grew exponentially during the nineteenth century, gave little attention to head protection for workers. Leather or cloth caps had dangerous oil wick lamps attached for lighting. They were replaced by tin and fiber-compound helmets with carbide lamp attachments, which sometimes still caused explosions. The safest contemporary helmets have battery-powered electric lamps. The U.S. Department of Labor's Occupational Safety and Health Administration (OSHA) establishes regulations for industrial workers' hard hats, which come in varying types for use in construction, welding, electrical work, and mining, with appropriate accessories.

### Sports Helmets

Protective helmets for sports were largely introduced in the twentieth-century Western world. Earlier, horseracing jockeys, polo players, and fencers wore head protectors. Advertisements for English bicycle manufacturers in the 1880s show cyclers wearing dark pith helmets. By 1915, bicycle racers wore heavy, round leather helmets, similar to those of aviators and American football players, although recreational cyclists went bareheaded. Af-

ter World War II, the “hairnet” made of leather strips attached to a round base became popular for racers; its style was later incorporated into Styrofoam and plastic headgear providing increased comfort and protection.

As bicycle technology and design produced faster, more efficient vehicles and the number of cyclers grew to the millions, issues related to safety came to public attention. Beginning in 1957, the nonprofit Snell Memorial Foundation promoted helmet safety after the head-injury death of internationally renowned car racer Pete Snell the previous year. This foundation developed car racing helmet standards and later bicycle helmet criteria, which are used complementing rules set by the American National Standards Institute (A.N.S.I.). Legislation followed that mandated government-approved, laboratory-tested, head-protecting helmets, effective since the 1990s in many countries including Australia, New Zealand, Canada, and the United States

Also in the 1990s, participants in other individual sports, such as motorcycling, skateboarding, and snowboarding, began adopting helmets. Ski helmet use proliferated in 1998 after the accidental deaths of the celebrities Sonny Bono and Michael Kennedy.

Design and durability for recreation sport helmets is usually classified by motorized and nonmotorized sports, including specifications for adults, children, and toddlers. Car racing helmets have neck braces, like those designed for pilots. Rollerblading helmets have ear covers but an open aerodynamic design for air circulation. Helmets for the more dangerous sport of skateboarding incorporate additional padding and snug fit, and bicycle helmets vary according to use—road racing, mountain biking, or touring.

Many ski helmets incorporate a plastic shell over an inner Styrofoam liner with venting system for thermal protection. A few are made from lighter carbon or platinum materials. In the early 2000s ski racer, hockey, and football helmets have large extending chin protectors. Accessories include headphones or built-in speakers for radio communication, CDs, tapes, MP3 or mini disc listening, and cameras. Appealing to youth, helmet manufacturers produce a wide range of helmet colors and novelty decals.

### Space Helmets

The most complex helmets ever created are for National Air and Space Administration (NASA) astronauts. They protect the wearer in alien environments against extreme temperatures (250° F to 250° below zero); micrometeoroids traveling up to 64,000 miles per hour; solar ultraviolet, infrared, and light radiation from the sun; and zero gravity conditions. The pressure helmet consists of a transparent polycarbonate (plastic) shell with aluminum neck ring that fits into and locks with the space suit neck ring. The helmet left side contains a feed port where water and food enter, and a purge valve. A vent port of synthetic elastomer foam is bonded in back with a ventilation

opening. The helmet functions as an integral part of the astronaut’s life-support system. Oxygen, warmed to avoid fogging the visor, enters the helmet rear and travels over the head downward to the front. Carbon dioxide exits, via a fan and tubing, along with respiration- and perspiration-caused humidity. These are also integrated with the Feed-water and Liquid Transport Systems, which cool the astronaut, and radio transmitter/receivers. Recent “micro display” technology provides a visual image inside the helmet allowing technical diagrams to be beamed the astronaut.

See also **Hats, Men’s; Hats, Women’s; Headdress; Military Style; Protective Clothing.**

### BIBLIOGRAPHY

- Alderson, Frederick. *Bicycling, a History*. New York: Praeger Publishers, 1992.
- Howell, Edgar M. *United States Army Headgear to 1854*. Vol. I (1969); *United States Army Headgear 1855–1902*. Vol. II (1976). Washington, D.C.: Smithsonian Institution Press.
- Les casques de combat: du monde entier de 1915 à nos jours*. Paris: Lavauzelle, Vol. I, 1984. (Paolo Marzetti, *Combat Helmets of the World*, 3 vols.)
- Nickel, Helmut, Stuart W. Pyhrr, and Leonid Tarassuk. *The Art of Chivalry, European Arms and Armor from the Metropolitan Museum of Art*. New York: American Federation of Arts, 1982.
- Reynosa, Mark A. *The Personnel Armor System Ground Troops (PASGT) Helmet*. Atglen, Pa.: Schiffer Publishing Ltd., 1999.

Beverly Chico

**HEMLINES** The term “hemline” entered fashion-speak in the 1930s. Prior to that time, the fashion press referred to skirt lengths and, since the 1920s, when hems first became a focus of fashion, slavishly reported on how many inches above the floor the latest season’s models were hemmed. While the press and fashionable women of the twentieth century obsessed about hemlines, throughout most of Western fashion history, skirt length was not an issue. Skirts reached the floor, except in clothing worn by members of the working class whose shortened garments facilitated their work, and, for brief periods of time during the 1780s and 1830s, when ankles were revealed. The history of the hemline is then one of twentieth-century dress, when the raising and lowering of women’s skirts made headlines, occasioned protest marches, and served as a symbol of revolution.

### 1915—Hemlines Rise

Designers and couturiers first raised hemlines several inches above the floor in 1915 when they created the wartime “crinoline” with a full, shortened skirt. Many women greeted this new look with pleasure and saw it as more practical and better suited to a time when women



were entering the workforce at unprecedented levels. After the war, as skirt lengths continued to rise—ten to twelve inches above the floor in 1925 to fifteen inches in 1927—so did the outrage against them by more conservative parties such as religious leaders, politicians, and university presidents, who tried to preserve the moral order of the previous century when women did not smoke or bob their hair and stayed at home to raise a family. The *New York Times* reported on 27 December 1925 that Mrs. John B. Henderson, a prominent Washington hostess announced the inauguration of a campaign to reform modern tendencies in dress and that, following the efforts of high dignitaries of church and education, her movement would frown on cigarette smoking by women and call on them to abandon immodest attire. However, changes in society accelerated by World War I fostered increasing economic independence for women and a focus on youth culture with which the shorter skirts became identified; thus the fashion for short skirts prevailed. In fact, attempts by designers to introduce longer skirts between 1922 and 1924 were met with protests by many women who felt the shorter skirts were more youthful and modern.

Skirts continued to rise until 1927, when they reached just below the knee. Not surprisingly, in the following year, designers began to lower hemlines, sensing that women were more amenable to change than they had been in the early 1920s. This news was a relief to textile manufacturers, to whom one inch of added skirt length meant they could sell millions of yards of additional cloth. While manufacturers heralded this change, consumers protested. The *New York Times* reported on 27 October 1929 that some women claimed that the effort to put them back in long skirts was “an insidious attempt to lure women back into slavery.” Other, more practical women refused to discard their current wardrobes in which their hemlines could not be lowered to the new fashionable standard, and buy new garments.

During the 1930s, hemlines did fall, but only for evening dress did they reach the floor. Women continued to wear shorter skirts during the day, now hemmed just above the ankle. This long, lean silhouette prevailed until the war years when regulations like L-85, issued by the U.S. government in April 1942, set skirt lengths at 17 inches above the floor and regulated other aspects of the cut of garments in an effort to conserve textiles. Evening dress remained more feminine, with floor-length full skirts made of tulle and marquisette that were not regulated under L-85. The “duration” silhouette survived throughout the war and suited women who, in even greater numbers than during World War I, entered the workforce and supported their families.

#### 1947—The New Look

Following the war, the French designer Christian Dior brought the focus of fashion back to Paris when he introduced his 1947 collection dubbed “The New Look”



**Christian Dior measuring a hemline.** Dior's New Look line, introduced in 1947, substantially increased the length of women's skirts. © BETTMANN/CORBIS. REPRODUCED BY PERMISSION.

by Carmel Snow, editor of *Harper's Bazaar*. The collection featured long, very full skirts that were a complete reversal of the wartime silhouette. While many greeted Dior's new look with pleasure and a chance to regain their femininity, others protested the profligate use of material after the deprivations of the war. Despite the protests, the New Look gained popularity on both sides of the Atlantic and helped revive the fashion industry in Paris. Dior became known as the tyrant of the hemlines, and he and his fellow couturier's collections were avidly followed and their efforts to raise and lower hems of singular importance to fashionable women.

By the beginning of the 1960s, couture's fashion dominance began to diminish. American and Italian designers had more prominence and the postwar, baby boom generation was beginning to reach their teen years and enjoy an independence and economic freedom not known in the past. Their rejection of their parents' look, exemplified by the Paris couture, led to an increasing interest in street fashion. Young designers, especially those in London, began to introduce clothes more suited to their generation. Mary Quant opened her own boutique on Carnaby Street in London in 1955, and when she couldn't find what she wanted wholesale, she began to design her own pieces, featuring short skirts worn with tights. Skirts continued to rise throughout the 1960s, and

by 1966, the miniskirt was at the height of its popularity with the young. By 1968, most established designers in New York and Paris showed short skirts as well.

Of course, as in the 1920s, this evolution in fashion caused an uproar among the more conservative members of society. Also, as in the 1920s, designers tried to reintroduce skirts with longer hemlines, the midi and the maxi, and met, this time, with fierce resistance.

### 1970—The Midi

In 1970, designers, along with manufacturers and retailers, introduced the midi-skirt, originally defined as anything hemmed below the knee or above the ankle. An intense marketing campaign was waged, in which retailers such as Bergdorf Goodman forced their salesgirls to wear the new-length skirt. Despite the effort, most women rejected the midi, refusing the dictates of fashion designers and retailers. Women organized into groups such as POOFF (Preservation of Our Femininity and Finances), FADD (Fight Against Dictating Designers), and GAMS (Girls Against More Skirt) to protest the new look and encourage others to not buy the midi.

Although longer skirts prevailed in the 1970s and shorter skirts in the 1980s, since the battle of the midi, the length of a women's skirt is no longer dictated by fashion designers but rather is a personal choice.

See also **Quant, Mary; Skirt.**

### BIBLIOGRAPHY

Most fashion histories do not address the story of hemlines in any depth. The best source of information is to be found in newspapers and magazines that covered its month-to-month and even day-to-day rise and fall. The source most easily searchable is the *New York Times*. Articles that proved particularly useful in writing this history are included below.

"The Day the Hemlines Went Down at Bonwit's." 4 August 1970.

"Dior, 52, Creator of 'New Look' Dies," 24 October 1957.

"Let the Hemlines Fall Where They May." 7 June 1967.

Morris, Bernadine. "The Rise of the Hemline Is Recounted." 5 April 1965.

Nemy, Enid. "Petitions and Parades: War of Descending Hemline Escalates." 28 April 1970.

Pope, Virginia. "Fashions for 1943 Feel War Effects." 2 January 1943.

"Society Women Hit at Immodest Dress." 27 December 1925.

*Pamela A. Parmal*

**HEMP** Hemp is a soft bast fiber from the stem of a plant, as are flax, jute, and ramie. Hemp plant fibers are three to twelve feet long and are made up of bundled cellular fibers. The plant itself, *Cannabis sativa*, is hardy and can be grown in most locations and climates around the world and requires moderate water. Its recorded use for

food, shelter, and fiber dates from at least 8000 B.C.E. Although ethnobotanists and others cannot be absolutely sure, it is thought that hemp was first grown in Asia.

Hemp can be fabricated for clothing, canvas, rope, and other uses. While hemp is not as soft as cotton, it is stronger than other cellulose fibers, such as flax, and more absorbent than cotton. Due to hemp's coarse and tough attributes it must be retted (rotted), a process by which the fibers are broken down microbially or chemically, decomposing the pectins that attach the bast fibers to the woody inner part of the stem known as the hurd or shive. Natural retting can be accomplished by simply allowing the cut stems to lie in damp fields for several weeks or by placing the stems in running water. The process of separating the bast fibers from the hurd is extremely difficult even when mechanized. The hurd is cleaned from the fiber by scutching (beating) and the fiber is further refined by hackling (combing). Thus, the retting, separating, and cleaning processes are lengthy and, therefore, expensive compared with other natural fibers. Overall, the production and processing of hemp is prohibitively expensive for routine consumer products.

Because hemp is naturally resistant to ultraviolet light, mold, and mildew, and to salt water, it has been used extensively for centuries by ships for sail canvas and rope. Farmers in the United States were encouraged to grow industrial hemp when, during World War II, the United States was denied access to abaca (called Manila hemp) from the Philippines. The U.S. Department of Agriculture produced a film titled "Hemp for Victory" and subsidized hemp cultivation by farmers. After World War II, industrial hemp cultivation was outlawed due to its association with marijuana hemp, a different variety of *Cannabis sativa*. In 1999, Hawaii became the first state since 1957 in the United States to plant hemp seeds legally. Hawaii's hemp project ended on 30 September 2003, when the Drug Enforcement Agency (DEA) ended Hawaii's attempt to grow industrial hemp. Industrial hemp is harvested in Canada, China, and most of Europe.

Hemp was reputedly used by Levi Strauss for the first Levi trousers sent to miners during the U.S. gold rush in the mid-1800s. Hemp fibers and yarns can be successfully combined with other natural fibers and yarns, including silk, and with synthetic fibers and yarns. Processed hemp is imported into the United States for use in industrial carpeting and upholstery as well as light supple dress weights.

In 2003, there were several businesses in the United States selling hemp fabrics or hemp blend fabrics for various uses. There were a large number of retailers who sold hemp and hemp blend products ranging from knitted T-shirts to woven and printed aloha shirts. Hemp fabrics become softer with repeated use and washing. Home products and accessories such as upholstery and table linens made from hemp are found to have strong market appeal to those seeking natural textile products.

At the turn of the twenty-first century, consumer use of hemp fabrics could be seen as a novelty touched by hemp's arcane association with forbidden marijuana.

See also **Hawaiian Shirt**; **Levi Strauss**.

#### BIBLIOGRAPHY

- Barber, E. J. W. *Prehistoric Textiles*. Princeton, N.J.: Princeton University Press, 1991.
- Blair, C. "Hemp Dies in Hawaii." *Honolulu Weekly*, 8 October 2003.
- Kadolph, Sara J., and Anna L Langford. *Textiles*. 8th ed. Upper Saddle River, N.J.: Prentice-Hall, 1998.
- Zimmerman, Malia. "Some See Profit in Hawaii Hemp." *Pacific Business News*, 9 July 1999.

Carol Anne Dickson

**HERMÈS** The world's most acclaimed maker and purveyor of status goods, Hermès has evolved from its days supplying harnesses to coach builders. The firm has been in family hands since it was begun in 1837, when Thierry Hermès (1801–1878), who had moved to France from Prussia in 1821, established his wholesale business near the old city wall on the rue Basse du Rempart in Paris.

In 1879 his son Émile-Charles Hermès (1835–1919) acquired the current flagship building at 24, rue du Faubourg Saint-Honoré and expanded the business into retailing by manufacturing and selling saddles along with related equestrian accoutrements. At the time the phrase "carriage trade" connoted the uppermost level of the haute monde: those who could afford to commission, equip, and maintain exquisite horse-drawn carriages, not to mention stables of purebred horses. Thus the Hermès clientele came to be composed of the upper crust of international society.

Somewhat unusually for a company associated with the stately past, Hermès adapted astutely to a rapidly changing world as the early twentieth century witnessed enormous changes in modes of transportation. Émile-Maurice Hermès (1870–1951), understood that people's preferred methods of travel had increasingly become an expression of their personae and position in society. Thus the company developed luggage, folding portable furniture, and other articles made specifically for travel by ocean liner, airplane, safari, or automobile. Nor was the world of the horse ignored, as riding became even more glamorous as a sport than it had been as a means of transportation.

Émile-Maurice's son-in-law Robert Dumas (1905–1978) was the next director of the company. Robert was succeeded by one of his sons, Jean-Louis Dumas (1938–), who held the reins after 1978. Numerous Hermès family members continued to be closely involved with the company, and the fact that it remained a family-run firm made all the difference in its continuing reputation for

superb quality. At Hermès tradition and innovation were almost paradoxically intertwined; what might have seemed like mechanical precision was achieved by carefully nurtured and trained artisans working entirely by hand. Besides a level of quality against which all other quality goods were measured, Hermès came to be best known for several of its products that progressed from practical items to best-sellers to classics to cultural icons.

#### Hermès Handbags

Few articles of women's attire carried the significance of a Hermès handbag in the early 2000s. The Hermès Kelly and Birkin bags entered modern consciousness as icons laden with status. As a plot element in Diane Johnson's novel *Le Divorce*, the Kelly bag was instantly recognizable to those conversant in the language of status and society as a sign that the American-in-Paris Isabel Walker had acquired a well-heeled older lover. And Martha Stewart's carrying two Birkin bags—not just a black bag but a brown one as well—received international attention at her 2004 trial and might have contributed to the distance the jurors perceived between her lifestyle and theirs.

The haphazard path of the Kelly bag's journey to icon status was part of its appeal. Originally a large bag for holding a saddle when it was introduced around 1892, the prototype of the Kelly bag was known as the Haut à Courroies, indicating that it had a high handle. During the 1930s the Haut à Courroies joined the Mallette and Bollide as roomy Hermès travel bags. An early depiction in the July 1937 issue of the French high-fashion magazine *Femina* showed two women waiting as a curved aerodynamic train pulled into the station. Both women were dressed in typically chic travel clothes of the period—sober and tailored. One carried a light-colored Mallette bag; the other, a dark and soft rather than stiff Kelly bag in dark leather. Both handbags represented a departure from the dominant purse of the 1930s, which was a simple flat small envelope.

The boxy Kelly bag got its nickname, famously, when Princess Grace of Monaco was shown on the cover of *Life* magazine in 1956 shielding her stomach with her handbag so as to ward off rumors (which would have been front-page news the world over) of her first pregnancy. In the 1950s Princess Grace was more than a fascinatingly beautiful style-setting woman; she was romance incarnate. She represented two types of American aristocracy—East Coast upper-class families and Hollywood celebrities—married to European royalty. Sales of the Kelly bag took off; it began to be used as a town bag, appropriate to wear with a tailored dress or suit.

Thirty or so years later, Jean-Louis Dumas chanced to sit next to the actress Jane Birkin on an airplane. Dismayed by the unkempt appearance of her straw carry-all, Dumas asked Birkin if she would help develop a new tote for the company. The much-coveted result was introduced in 1984. Like the Kelly, the Birkin bag had its origins in the world of luggage. An early version of the bag





### THE ORANGE BOX

Appropriately for a firm that can be said to have invented the nonprecious status object, the Hermès box itself became a coveted item, decorating glamorous foyers and boudoirs, and being auctioned off on Internet websites. The box's distinctive color and texture were originally designed to resemble pigskin, one of the most popular sporty materials used for Hermès products of the 1920s and 1930s.

had appeared in a 1963 advertisement on top of a stack of small Hermès suitcases. That women of the early twenty-first century required the equivalent of antique luggage to help contain a day's necessities spoke volumes about their lives having become more rather than less complicated.

Many of the hundreds of Hermès handbags became classics, including Jacqueline Kennedy Onassis's favorites—the casual Trim, the more formal Constance with its large H-shaped clasp, and the Mangeoire, made like a horse's feed bucket with holes through which a scarf could be threaded. The Bollide, however, deserves special mention for its use of zippers. While in Canada during World War I, Émile-Maurice Hermès was intrigued by the sliding fastener used to close the top of his Cadillac convertible. Although Elsa Schiaparelli usually gets the credit for having discovered zippers, Hermès used them throughout the 1920s for all sorts of sports clothes, luggage, and purses, including the zippered and padlocked precursors of the Bollide and Plume handbags.

### Hermès Scarves

The famous Hermès scarf, known as a silk carré or square, was launched in an advertisement in December 1936 as a coming attraction of 1937. Called "*Jeu des omnibus et dames blanches*," its pattern was based on a woodcut of an eighteenth-century game. Hermès scarves of the 1930s tended toward modernist geometric patterns. By designing a large square of silk printed with boldly scaled figural scenes, Hermès invented a whole new genre of fashion accessory, one that maintained its popularity for more than seventy years. Although all sorts of patterns came later—the stable of designs hovered around a thousand in the early 2000s—the typically bold scale of the patterns never wavered, and also influenced the design of high-fashion prints during the late 1980s. Besides the patterns, many based on Hermès's private museum holdings of art and antique objects, what made the scarves instantly recognizable as Hermès products was the quality of the

crisp silk twill, woven in Lyons from raw silk from China, and the precision printing. Each scarf design made use of as many as forty-five screens and 75,000 tones, resulting in unparalleled brilliance of color.

### Hermès Ties

The first Hermès ties for men were dark, with discreet geometric designs, and made their debut in 1953. After the 1960s Hermès ties were designed by Henri d'Origny. They typically featured small repeated equestrian or sailing-inspired patterns in dazzling colors not usually associated with menswear. Hermès ties were steadily popular for more than forty years, no small feat in the fickle world of fashion.

### Hermès Fashions

At the turn of the twenty-first century, the global brand conglomerates that dominated the market for luxury goods vacillated between emphasizing star designers and brand names. Hermès had offered clothes for sport, both custom-made and ready-to-wear, since the 1920s, but the firm's typical style was better known than the contribution of any particular designer. Since the 1980s, the names of designers associated with Hermès included Eric Bergère and Martin Margiela—whose most lasting contribution may have been an accessory rather than a line of clothing, namely a double-wrapped watch strap. Jean Paul Gaultier, who presented his first collection for Hermès in the fall of 2004, tapped a mien conspicuously lacking from contemporary fashion—the insouciance of the aristocrat born with a good seat. Designs in this mood included fringed cashmere coats fitted like horse blankets that had been thrown around the shoulders and belted, and a leather corset reminiscent of a saddle fastened with the famous Hermès padlock in the style of a chastity belt.

See also **Celebrities; Gaultier, Jean-Paul; Handbags and Purses; Leather and Suede; Margiela, Martin; Scarf; Schiaparelli, Elsa; Silk.**

### BIBLIOGRAPHY

- Nadelson, Reggie. "Out of the Box." *Departures* (May–June 2002): 142–178.
- Remaury, Bruno, ed. *Dictionnaire de la mode au XXe siècle*. Paris: Editions du Regard, 1994.
- Reynolds, C. P. "Hermès." *Gourmet*, February 1987, 42–122.

Caroline Rennolds Milbank

**HEROIN CHIC** At the U.S. Conference of Mayors on 21 May 1997, President Bill Clinton triggered a media furor on both sides of the Atlantic with his comments about the dangers of so-called heroin chic in contemporary fashion imagery. "You do not need to glamorize addiction to sell clothes," he asserted. "The glorification of heroin is not creative, it's destructive. It's not beautiful, it's ugly" (White House Briefing Room p.1). The pho-

tographs in question showed emaciated models, eyes half-closed, skin pale and clammy, heads twisted in apparent abandon against a backdrop of seedy, anonymous hotel rooms and dirty apartments. Clinton's fears had been heightened by fashion photographer Davide Sorrenti's death at twenty-one, from a drug overdose on 4 February 1997. The gap between image-makers' and models' real lives and constructed fashion photographs blurred. Since the 1970s fashion designers' struggles with drug addiction, for example, Yves Saint Laurent and Roy Halston, had been related alongside discussions of their work and influences. In the 1990s media coverage merged actual drug abuse and fashion scenarios created to suggest decadent and nihilistic rejections of conventional notions of beauty. Clinton decried what he saw as fashion's glamorization of heroin use, and his words were reinforced by fashion journalists such as Amy Spindler of the *New York Times*, who felt that fashion insiders were irresponsible, that they ignored drug use by models and photographers, and that they made images that spoke of dark addictions in order to promote clothing and fashion ideals.

The ensuing media debate was further fueled by revelations of heroin abuse within the fashion industry. It is notable, though, that heroin chic existed only at the level of representation, in photographs and in styling for catwalk shows, rather than in actual clothing. It was a conjuring of signifiers that were frequently intended to evoke a more realistic idea of beauty and which its creators felt linked to their everyday lives in a way that more traditional fashion photographs, which relied upon sanitized visions of artificially enhanced perfection, never could.

This realist aesthetic had evolved since the early 1990s, with the London-based photographers Corinne Day and David Sims, and German-born Juergen Teller highly influential in its formation. They worked with like-minded stylists, most importantly Melanie Ward (with Day) and Venetia Scott (with Teller), who sought out secondhand clothes to mix with designer and high street garments to create a mood or atmosphere that related to their own experiences. Their work responded to post-rave youth culture, disenchantment with politics, and the impact of the global recession. It drew upon the intensity and fluidity of the rave scene and the darker obsessions and sense of alienation of rock bands such as Nirvana.

They were influenced by 1960s and 1970s fashion photographers who had experimented with notions of morality and acceptability, such as Bob Richardson and Guy Bourdin, and combined their images' often jarring, filmic quality with the raw emotion and intimate expositions of Larry Clark and Nan Goldin. In the 1990s, fashion photographers locked into a tradition of documentary photography that drew significance from traces of the everyday and sought to express the intensity of the moment. Goldin and Clark had both photographed real scenes of sex and drug use. They used the camera as a visual record, an external memory of their lives, and that

is what 1990s photographers—Sorrenti, Teller, and Day—integrated into their own work.

They mainly worked for style magazines such as *The Face*, *Dazed and Confused*, and *i-D* in London, and therefore drew a young audience that responded to the stripped-down settings and light touch of Ward's and Scott's styling, which created outfits that seemed to have been thrown together from old favorites rather than crisp, new clothes. The models they chose, Emma Balfour, Rosemary Ferguson, and Kate Moss among them, were skinny and androgynous, and embodied a challenge to the more Amazonian physiques of previous models. However, their thinness at times seemed acute, and their glazed, Vaseline-lidded eyes and pale faces were jarring among glossier beauty ideals shown in advertisements in the same magazines.

Although other areas of culture were equally preoccupied by images of youthful rebellion, through drugs and partying, the models' fragile bodies appeared bruised and vulnerable. Their delicate features seemed blurred by smudged makeup and incongruous in the context of dirty rooms or overgrown countryside. They recalled the emaciated style shown in the 1981 cult film, *Christiane F.*, which depicted the life of a teenage heroin addict. Models were often shown lying prone, perhaps asleep, perhaps passed out.

Irvine Welsh wrote about heroin addiction in *Trainspotting*. Films, such as the one inspired by his book made in 1996; *Drugstore Cowboy*, 1989; *Pulp Fiction*, 1994; and *The Basketball Diaries*, 1995, were all far more graphic in their scenes of drug abuse; they were also able to show their protagonists' suffering and turmoil. Fashion images, however, presented snapshots that covered perhaps eight magazine pages, a mini-narrative that was ambiguous, with drugs never actually explicit but implied to some onlookers by gestures, settings, and facial expressions.

By the time Clinton spoke out about so-called heroin chic, a term that had been circulating, along with "junkie chic," in the press for the past year, many felt the style was over, and fashion had moved on. It had been a strand within fashion that had grown up over the previous years, coming to fruition in 1993, as evidenced by, for example, fashion shoots for *The Face* of that year, and it gradually shifted, into more straightforward documentary work for Day and Teller, into a darker, more erotic fantasy for photographers such as Sean Ellis, or into more explicit imagery for Terry Richardson. Camilla Nickerson and Neville Wakefield's book, *Fashion, Photography of the Nineties* (1996), brought together many of the key images of the period and showed the breadth of the realist style, of which heroin chic was only a part. The outcry came as mainstream labels appropriated the aesthetic, Calvin Klein included, adding an edge to their brand. As it shifted context, and therefore reached a wider audience, heroin chic's suggestions of internalized violence and illicit pleasures became increasingly controversial.

## HIGH HEELS

Heroin chic was a symptom of cultural anxiety, and fashion's contradictory position within Western culture meant that its exploration of uncomfortable themes of alienation, deathliness, and beauty were problematic, especially at a time when representations of reality and fiction were ever more blurred.

See also **Extreme Fashions; Fashion Photography.**

### BIBLIOGRAPHY

Arnold, Rebecca. "Heroin Chic." *Fashion Theory, The Journal of Dress, Body and Culture* 3, no. 3 (September 1999): 279–295.

———. *Fashion Desire and Anxiety: Image and Morality in the 20th Century*. New Brunswick, N. J.: Rutgers University Press, 2001.

Nickerson, Camilla, and Neville Wakefield, eds. *Fashion: Photography of the Nineties*. Zurich, Berlin, and New York: Scalo, 1996.

### Internet Resource

White House Briefing Room. "White House Press Release: Remarks by the President at the U.S. Conference of Mayors." Available from <http://www.treatment.org/news/mayors.html>.

*Rebecca Arnold*

**HIGH HEELS** High-heeled shoes, perhaps more than any other item of clothing, are seen as the ultimate fashion symbol of being a woman. Little girls, who raid their mother's closets for dressing-up props, gravitate toward them. A first pair of high heels was often a rite of passage into womanhood.

To be so fashionably shod is often detrimental to one's feet, but a high-heeled shoe is widely perceived as the sexiest, most feminine shoe a woman can wear. High heels have the ability to change radically the wearer's posture and appearance. Heels make the leg look longer, slimming calves and ankles. A woman's silhouette changes. Her breasts are thrust forward and her bottom pushed out to create a seductive S-shape that helps to create that sexy walk. These physical changes influence how a woman feels and often how she is perceived, so creating the paradox of wearing heels. On the one hand, high heels are all powerful. A woman becomes taller, striking a defiant pose that signifies sexuality and power. In heels she can take on the world. Yet, high heels can also create a helpless woman, teetering and unsteady, unable to run for the bus, passive and weak.

High heels have had a long association with sexual fetishism—from the dominatrix in black leather high-heeled boots to the submissive in bondage shoes.

### Origins

Heels were first introduced in the 1590s. In the 1660s Louis XIV of France made high heels fashionable for men. As a relatively short man he coupled high heels with tall wigs to create an illusion of height. Royal customization gave rise to red heels, a symbol of status and power, initially only worn by those in the royal court. High red heels continued to be fashionable into the 1770s.

### The Eighteenth Century

The French fashion of the 1770s and 1780s saw high heels placed under the heel arch of the foot, causing the wearer's toes to be crushed in the upturned pointed toe, yet tilting the wearer forward in a provocative manner.



The resulting pain was worth it for the very fashionable look. A satirical poem of the time says it all: "Mount on French heels/ When you go to a ball /'Tis the fashion to totter/ and show you can fall!" Toward the end of the eighteenth century, heels became lower or wedged, disappearing altogether by around 1810.

### The Nineteenth Century

From the 1850s women's heels began to make a comeback, and by the 1860s fashionable heels could measure 2.5 inches. In June 1868 the *Ladies Treasury* told its readers: "High-heel boots are universal, notwithstanding that medical men have been writing very severely against them. They say the fashion causes corns, cramps, lameness at an early age, lessens the size of the calf and thus makes it lose its symmetry" (Swann, p. 48). From 1867 there was also the introduction of a straight, slender high heel known as the Pined PINET, after the French shoemaker Francois Pinet.

In the 1890s some courtesans wore a style known as the Cromwell shoe, based on the Victorians' rather fanciful ideas of the shoes worn by Oliver Cromwell and his followers; this style had a heel of up to 6.5 inches.

Early heels were carved from wood and covered with leather or fabric used for the upper shoe. To strengthen the area between the sole and the heel the leather sole often ran down the heel breast.

### The Twentieth Century

The Cuban heel with straight sides appeared in 1904. It was usually constructed using pieces of leather stacked to create its height. The bar shoe was the classic style of the 1920s, sporting a high Louis or Cuban heel. Jewelled heels decorated with paste, diamante, and enamels were featured on evening shoes.

A significant development in the history of high heels came on the wave of Christian Dior's New Look in 1947. This style required a correspondingly slim and elegant high heel. Previously high slim heels were prone to breaking. The problem was solved when a steel rod was inserted through a molded plastic heel. Stilettos were first mentioned in the *Daily Telegraph* on 23 September 1953. Initially high fashion, made popular by the French shoe designer Roger Vivier, all women were soon wearing them until the early 1960s. Stilettos caused many practical problems, including the pitting of wooden floors and getting caught in street gratings.

It was also in the 1960s that for the first time since the 1720s, the high heel was reclaimed by men in the form of the Cuban heel on what were known as Beatle boots, a style made popular by the the Beatles. In the 1980s high stiletto heels made a comeback, as power dressing for women at work became de rigueur. Coupled with a shoulder-padded masculine tailored suit and red lipstick, the high heel symbolized sexual power and dominance, a "don't mess with me" visual attitude.

Since then the high heel has never really disappeared. Its resurgence in the early 2000s was reflected in the popularity of Manolo Blahnik's shoes in the TV show *Sex and the City*. Some women only wear high heels for special occasions as formal wear, while others wear them all the time. Whatever the preference is, the high heel will never go away.

See also **Blahnik, Manolo; Boots; Shoes; Shoes, Women's.**

#### BIBLIOGRAPHY

- McDowell, Colin. *Shoes: Fashion and Fantasy*. London: Thames and Hudson Inc., 1989.
- Pattison, Angela, and Nigel Cawthorne. *Shoes: A Century of Style*. London: The Apple Press, 1998.
- Pratt, Lucy, and Linda Woolley. *Shoes*. London: V&A Publications, 1999.
- Swann, June. *Shoes*. London: B.T. Batsford, Ltd., 1982. Excellent historical overview.

Rebecca Shawcross

**HIGH-TECH FASHION** High-tech fashion uses advances in science and technology to design and produce fashion products. Methods used in high-tech fashion borrow from technologies developed in the fields of chemistry, computer science, aerospace engineering, automotive engineering, architecture, industrial textiles, and competitive athletic wear. Fashion projects an image of rapid change and forward thinking—a good environment for use of the latest technologies in production methods and materials. As technology becomes more integrated with one's everyday life, its influence on the fashion one wears continues to increase.



**Airplane Dress.** Designed by Hussein Chalayan, the Airplane Dress is representative of how advances in science and technology are used to create fashion products. COURTESY OF CHRIS MOORE. REPRODUCED BY PERMISSION.



**High-tech fashion.** A Pioneer Corp. employee demonstrates the latest in Japanese streetwear—the wearable PC. In the early 2000s, Pioneer was attempting to showcase more functions to the heat-proof, fabric-like display on the sleeve. © REUTERS/CORBIS. REPRODUCED BY PERMISSION.

Historic technological innovations such as the development of the sewing machine, the zipper, and synthetic fibers have influenced how garments are made, how they look, and how they perform. Elsa Schiaparelli was a noted designer of the 1930s and 1940s who had an eagerness to experiment with synthetic fibers. She introduced the first zipper to Paris couture. World events delayed advancements in techno fashions until the race for space began to influence designers in the 1960s. André Courrèges's use of bonded jersey, Paco Rabanne's experimentation with metal-linked garments, and Pierre Cardin's pioneering vacuum-formed fabrics began to push the boundaries of fashion through experimentation with technology and innovative materials. Plastics, foam-laminated fabrics, metallic-coated fabrics, and a sleek fashion silhouette launched fashion into a new realm.

Technological advances continue to influence fashion with new developments in materials, garment structuring and sizing, methods of production, and the quest for fashion that reflects the look and lifestyle of the future.

### Techno Materials

Techno materials include fibers, textiles, and textile finishes engineered for a specific function or appearance. The U.K. designer Sophia Lewis believes that “the greatest potential for the future lies in experimental fashion using advanced synthetics to promote new aesthetics and methods of garment construction” (Braddock and O'Mahony, 1999, p. 80). While most synthetics of the twentieth century were developed to mimic natural fibers, the new synthetics are engineered to be strong and durable even when lightweight, transparent, or elastic. Blending natural fibers with synthetics in new ways to produce “techno-naturals” is adding to the aesthetic and performance advantages of textiles.

Recent fiber developments include microfibers, fibers regenerated from corn and milk proteins, metallics, and fiber optics. Microfibers can be produced at a thickness less than that of a silk filament to create fabrics that are soft and fluid with great strength and capabilities of performing under extreme environmental conditions.



New processes and experimentation have led to eco-friendly fibers made from renewable resources such as corn and soybeans. Another eco-friendly advancement is the genetic development of naturally colored cotton, eliminating the need to use caustic dyes. Shape memory alloys (SMAs) made of nickel and titanium can be produced in wire or sheet form to be incorporated into fabrics that retain memory of their original shape.

Holographic fibers can be used to reflect colors and images from the wearer's surroundings. Fiber optics incorporated into fabrics can be used to transmit messages.

While traditional fabrication methods of weaving and knitting remain, new fabric technologies are emerging. Knits are being fashioned to form seamless garments that are shaped to fit any figure. Nonwovens are inexpensive to produce and are adaptable to multiple end uses. Experimentation with a variety of finishing techniques for nonwovens has introduced a new aesthetic option for designers such as Hussein Chalayan, who fashioned dresses of Tyvek nonwoven fabrics. Foams give options of developing sculptural shapes for the body as well as providing insulation. Synthetic rubber allows garments to fit close to the body with freedom of movement in many applications, from wet suits to evening gowns.

Fabric finishes are providing new options for designers. Fabrics can be coated with microencapsulated substances such as vitamins, fragrances, insect repellents, or bacteriostats. As the tiny capsules burst, the substance is released onto the skin. Phase-change technology, originally developed by NASA, produces fabrics that adapt to changes in temperature with the potential of providing garments that heat and cool the body. Phase change materials (PCMs) can be incorporated into fibers or sandwiched between layers of fabrics. The PCM can absorb and distribute excess heat throughout the fabric before storing it. As the environment cools, the PCM solidifies and releases the stored heat to the wearer.

Textile designers have a heightened interest in combining both chemical and mechanical processes to develop beautiful and practical fabrics. Experimentation with high-tech interpretations of simple finishing techniques, such as calendaring or mercerization, can give fabrics a variety of textures, from smooth and lustrous to crinkled or sculpted. The finish can dramatically transform a fabric's visual and tactile qualities as well as performance characteristics like stain resistance, wind resistance, or permanent-press features. Thermoplastic fibers can be molded with heat to create permanent three-dimensional surfaces.

Printing is another method of transforming the surface of a textile that has been advanced through experimentation with new technology. Computer Aided Design (CAD) is a tool that enables textile designers to create modern print patterns, including the feeling of three-dimensional space. The computer has replaced many of the labor-intensive production demands needed to cre-

ate surface pattern. It provides flexibility and speed, and can be used with a range of printing options to create a new visual aesthetic. Ink-jet printing can move a design from the computer screen to the fabric with speed and flexibility. Heat-transfer allows for great experimentation by developing a design on special paper and then transferring it to a synthetic fabric with heat and pressure. Relief printing with synthetic rubbers and metallic powders creates textural surfaces that are modern and functional.

In addition to looking at technology for direction, many designers have a renewed interest in traditional finishing techniques such as pleating, shibori, and resist-dyeing. The strength of the pioneering Japanese textile industry is based on the combination of new technologies with traditional craft. Rei Kawakubo, Issey Miyake, Yohji Yamamoto, Junya Watanabe, and Michiko Koshino have been leaders in combining traditional craft techniques with cutting edge technology. These designers pioneered a trend toward cooperative partnerships between textile designers and fashion designers, enhancing the development of textiles and garments in a synergistic fashion. This is a model copied worldwide.

In contrast to the strong trend to use technological advances, a sentiment echoed by many designers worldwide is for a more balanced perspective. It is the belief that a design is enhanced by evidence of the hand that created it; thus imperfection, individuality, and an honest approach to materials is highly valued. In many respects, this effort to reject the uniformity of mass-produced garments has been attributable to rapidly evolving technology and move toward fashion that expresses individuality. The explosion of the Internet at the millennium added to this shift by presenting new possibilities in fashion.

### Garment Production

The last quarter of the twentieth century saw rapid development of computer technology. Computer-aided design and computer-aided manufacturing (CAD/CAM) dramatically changed the process of designing and manufacturing garments by reducing many labor-intensive processes, increasing speed and accuracy, and lowering costs. Garments can be developed with CAD from sketch to pattern and cutting, either locally or globally, in a fraction of the time it took.

Designers research trend and development information, communicate with clients and suppliers, and sell and market designs in a wireless Internet environment where yesterday is too late. Fashion news is available hours after an event occurs, and the Internet has even replaced some live fashion events. Walter Van Beirendonck, Helmut Lang, and Victoria's Secret have used Internet methods of showing designs. This rapid flow of information, an interest in individuality, and the technology to support rapid production have led to the development of mass customization.

Mass customization is a design, manufacturing, and marketing concept that allows a customer to order a gar-

ment to specifications for approximately the same cost as off-the-rack. Part of the specifications may include custom sizing that is achieved with the use of a body scanner, which records measurements that are translated to individualized patterns. This scanned measurement information, along with personal preferences and shopping history, can all be stored on a credit card to facilitate the shopping experience. There are many benefits to this method of operation, including a satisfied customer, less wasteful production, and sales made at full price.

Customization concepts may also support the development of new apparel production technology in molding materials, industrial fusing methods, and seamless knitting technology—providing a glimpse at forming garments without needle and thread. Hussein Chalayan's remote control dress uses composite technology borrowed from the aerospace industry to form molded panels that are clipped together and can move to reveal different parts of the body. The forerunner of this molding technology was the molded bra cup developed in the 1960s. Designers have worked with lasers for cutting patterns and creating intricate, cut designs, or ultrasound to fuse the seams of thermoplastic fabrics. New developments in circular knitting machines move from simple tube knits to entire garments shaped to the body on the machine. Industrial materials that include metals, glass, plastics, and industrial mesh are providing inspiration from architecture for many clothing designers. Traditional apparel production methods are revised or even abandoned according to the needs of the new materials and the way they interact with the body.

### Fashions for New Lifestyles

Sports and active lifestyles have influenced fashions of the early 2000s. Apparel technologies developed for competitive sports are incorporated into fashions for everyone. Research and innovative thinking have advanced sportswear with attention to both performance and aesthetics. Garments that maintain body temperature, cool the body, and improve performance are researched and engineered with a new aesthetic that has moved the garments out of the gym and into everyday life.

Current fashion is making accommodations for the consumer's changing electronic lifestyle, including garments with pockets for cell phones, jackets with connections for electronic music players, and stylish bags to tote laptops. Researchers are developing "intelligent" fashions incorporating wearable computers, communication systems, global positioning systems, and body sensors. Systems may have the capability to allow the wearer to surf the Internet, make phone calls, monitor vital signs, and administer medication. While much research remains to be done, initial exploration has begun at MIT's Media Lab, Starlab, Charmed Technology, and International Fashion Machines. The goal of these groups is to develop prototypes of wearable electronics and to explore the synergy required between computer science, fashion, health

care, and defense to produce marketable, user-friendly products. Advances and innovative thinking in the production of apparel and communication platforms and networks will be required to move these concepts forward.

The changing world political climate and the continuing challenges of world health present new opportunities for science to address wearable solutions. Development of protective apparel against bioterrorist attack and spread of infectious disease commands research dollars from governments worldwide. These investments will most likely lead to exciting new materials that ultimately result in new fashion.

Fashion is a reflection of the times, and thus incorporates current scientific and technological developments. Change is a constant in fashion, and one can look forward to ever-developing advanced materials and methods and perhaps even new purposes for fashion.

See also **Extreme Fashions; Futurist Fashion, Italian.**

### BIBLIOGRAPHY

- Braddock, Sarah E., and Marie O'Mahony. *Techno Textiles: Revolutionary Fabrics for Fashion and Design*. London: Thames and Hudson, Inc., 1999.
- O'Mahony, Marie, and Sarah E. Braddock. *Sportstech: Revolutionary Fabrics, Fashion and Design*. London: Thames and Hudson, Inc., 2002.
- Quinn, Bradley. *Techno Fashion*. Oxford and New York: Berg, 2002.

*Elizabeth K. Bye and Karen L. LaBat*

**HIJAB** Equating the terms *hijab* and "veil" is a common error. "Veil" is an easy, familiar word used when referring to Arab women's head, face, and body covers. *Hijab* is not the Arabic equivalent of veil—it is a complex and multilayered phenomenon.

"Veil" has no single word equivalent in Arabic. Instead many different terms refer to diverse articles of women's and men's clothing that vary by region, era, lifestyle, social stratum, stage in the life cycle, and gender. Adding to this complexity is the fact that some covers and wraps worn by both sexes have multiple usages and are manipulated flexibly to cover the face when socially required. For example, women use head covers or large sleeves to hide the face in ways that can communicate kinship, distance, or social stratum of a person they encounter. Men, as well, can use their head covers in the same way.

"Dress" is a more inclusive word and has an Arabic equivalent, *libas*, that in Arab-Islamic culture connotes meanings beyond material form and function. *Libas* extends conceptualization to notions of family and gender implying haven-shelter-sanctuary—a protective shield, as it were. Dress is integral to Islam's sacred beginnings and

explicit Qur'an references reveal a role for *libas* (dress) in Islam's conceptualizations.

Dress in Arab and Islamic culture can be viewed in two ways: the traditional-secular dress (clothing adopted through customary practices over time without religious connotation) and religious dress (clothing forms justified or believed to be justified or prescribed by religious sources or authorities). The Christian example of the latter would be the nun's habit. The Afghan burqa, the object of scrutiny and attack by some feminists preceding the Afghan invasion by the United States, exemplifies the traditional or secular form of dress. Hijab is the religious kind of cover in an Islamic context. The English word "veil" can apply to either secular or religious kind of cover. Hijab is more culturally specific than veil, but embodies multiple cultural levels of meaning and is better understood when embedded in wider sociocultural and sociopolitical contexts. Muslims use Qur'anic references to support their adoption of practices or in taking positions regarding related issues, and there are indeed some references to hijab in the Qur'an.

### Qur'anic References

In the Qur'an (considered the primary and divinely revealed source), but mostly according to the *Hadith* (Prophetic Narrative, a secondary worldly source), evidence suggests that the Prophet Muhammad had paid much attention to dress style and manner for Muslims in the emerging community, gradually developing a dress code. There was a specific focus on Muslim men's clothing and bodily modesty particularly during prayer, but reference to women's body cover is negligible.

Within the Qur'an's references to hijab, only one concerns women's clothing. Muslim men and women who argue in the early 2000s for the Islamic dress and behavioral code usually cite two chapters in support of modesty for women and for an Islamic basis for wearing the hijab.

As Islam gradually established itself in the Madina community, after it had been chased out of its place of origin in Makka, the interpretation of "seclusion" for Muhammad's wives originated from sura (chapter) 33, ayah (verse) 53 in which hijab is mentioned:

O believers, enter not the dwellings of the Prophet, unless invited. . . . And when you ask of his wives anything, ask from behind a hijab. That is purer for your hearts and for their hearts. (33:53)

Evidence suggests that this sura is ultimately about privacy of the Prophet's home and family and the special status of his wives in two ways—as Prophet's wives and as leaders with access to Islamic information and wisdom who are increasingly sought by community members. There was a need to protect their privacy by regulating the flow of visitors and the comportment of the men who entered upon the women's quarters. Here "hijab" refers not to women's clothing, but to its use as partition or curtain to provide privacy for women.

Sura al-Ahzab (33), ayah 59 enjoins the Prophet's wives, daughters, and all Muslim women to don their *jilbab* for easy recognition and protection from molestation or harassment:

O Prophet tell your wives, daughters and believing women to put on their *jilbabs* so they are recognized and thus not harmed (33:59).

*Jilbab* refers to a long, loose shirtdress, and does not connote head or face cover. This verse distinguishes the status of the Prophet's wives from the rest of the believers, and the other (33:53) protects their privacy from growing intrusions by male visitors.

Sura 24 refers to *khimar* (head cover) in the general context of public behavior and comportment by both sexes. In it ayah 31 (24:31) has been widely cited in scholarly works, often in isolation from the rest of the verse, distorting the meaning, implying that women are singled out for "reserve" and "restraint." Preceding it, ayah 30 addresses men first:

Tell the believing men to lower their gaze and conceal their genitals; for that is purer for them, God knoweth what they do.

Ayah 31 follows, continuing the same theme:

And tell the believing women to lower their gaze and conceal their genitals, and not reveal their beauty, except what does show, and to draw their *khimar* over their bosoms, and not to reveal their beauty except to . . . etc. (emphasis added).

Evidence from the usage of hijab in the Qur'an, from early Islamic discourse, and subjected to anthropological analysis, supports the notion of hijab as referring to a sacred divide or separation between two worlds or two spaces: deity and mortals, good and evil, light and dark, believers and nonbelievers, or aristocracy and commoners. The phrase "*min wara' al-hijab*" (from behind the *hijab*) emphasizes the element of separation and partition.

When referring to women's clothing, the terms often used are *jilbab* (long, loose-fitting shirtdress) and *khimar* (head cover). Neither hijab nor *niqab* are mentioned. *Niqab* and *lithma* are terms that unambiguously refer to face cover. Hijab, which only refers to head (shoulder) cover and to the general Islamic attire, is not mentioned in these two suras either. In other references to comportment and modest way of dressing appropriate to the new status of the Prophet's wives, hijab is not mentioned either. When it is used in other suras, the word conveys more the sense of separation than veiling or covering.

The Qur'an and the contemporary Islamic movement make clear that Muslim men and women are to carry themselves in public with a sense of reserve and restraint. Exhibitionist public comportment, through behavior, dress, voice, or body movement, is frowned upon, and becomes associated with *Jabiliyya* (pre-Islamic era) that is not confined to a historical moment, but rather becomes a state and a condition of society that can oc-





**Hijab.** The *hijab* is used as women's headcover in the Islamic world. Although it is commonly, and mistakenly, referred to simply as a veil, it serves the higher purpose of representing Islamic identity and morality. © JULIE PLASENCIA/SAN FRANCISCO CHRONICLE/CORBIS. REPRODUCED BY PERMISSION.

cur at any time when social and moral controls are abandoned. But overall the contemporary movement is not simply about clothing but about a renewal of a cultural identity and traditional ideals and values.

### Etymology and Meaning

The cultural and linguistic roots of “hijab” are integral to Islamic (and Arab) culture. “Hijab” translates as cover, wrap, curtain, veil, screen, partition. The same word is used to refer to amulets carried on one's person (particularly for children or persons in a vulnerable state) to protect against harm.

By the nineteenth century, upper-class urban Muslim and Christian women in Egypt wore the *habarab*, which consisted of a long skirt, a head cover, and a *burqa*, a long rectangular cloth of white transparent muslin placed below the eyes, covering the lower nose and the mouth and falling to the chest. When veiling entered feminist nationalist discourse during British colonial occupation, “hijab” was the term used by feminists and nationalists and secularists. The phrase used for the removal of urban women's face and head cover was *raf* (lifting) *al-hijab* (not *al-habarab*: the term used for cloak or veil

among upper-class Egyptian women up to the early 1900s).

### Three Arab Feminisms

Muslim and Christian women of the upper and middle classes described the Egyptian feminist movement at the turn of the century as a secular movement. Some observers linked European colonialism and feminism, distinguishing two feminist trajectories: a Westward-looking feminism and a more local one. In neither form have women made veiling or unveiling the central issue. Rather, some prominent men advocated feminist programs and called for reform centering on women's veiling. Removing the veil was not part of the official feminist agenda of the Egyptian Feminist Union. Importantly, when the most prominent Arab feminist, Huda Sha'rawi, “lifted the hijab” as the famous public gesture came to be described, she had only removed the face cover (*burqa* or *yashmik*), which was worn by upper-class women at the turn of the century, but kept the head covering. Technically, therefore, Huda Sha'rawi never “lifted the hijab,” since “hijab” refers broadly to the whole attire, but more commonly to the head covering. Some attribute her success in feminist

nationalist leadership, compared with other contemporaries, to the fact that she had respect for the traditional attire. In her memoirs she mentions being congratulated for “my success in . . . lifting the hijab . . . but wearing the *hijab shar’i* (lawful or Islamic hijab)” (Sha’rawi 1981, p. 291). This distinction is important and assumes special significance because the other prominent feminist, Malak Hifni Nasif, opposed mandatory unveiling for women. Her agenda in early 1900 stressed two elements absent in Sha’rawi’s feminist agenda: the opening of all fields of higher education to women and demanding space accommodation for public prayer by women in mosques. These local elements contrast to French-influenced agendas by other feminists. A third movement developed through the seeds sown since 1908 calling for the importance of Islam and the wearing of the hijab, formed under the initiative of Zaynab al-Ghazali in the 1970s espousing Islamic ideals and supporting family values. None of the three feminisms espoused calling for abandoning the hijab.

### Contemporary Movement

Beginning in the 1970s in Egypt an Islamic movement emerged. The Islamic movement reasserted a cultural historical identity and stood for resisting hegemonic colonial occupation. It centered initially on youth and college-level young adults and broadened across generations and social strata and spread throughout the region. The public appearance of an innovative form of dress for men and women without exact historical precedent characterized the movement. This new style was not a return to any traditional dress form, and had no tangible model to emulate, and no industry behind it—not one store in Egypt carried the new garb in the 1970s. In the early 2000s there are many stores that sell this outfit throughout the region, on the Internet, in Europe, and in the United States. The dress was referred to as “the Islamic dress,” in Arabic called *al-ziyy al-Islami* or *al-ziyy al-Shar’i*, or more commonly *al-hijab*.

This new fashion seemed incomprehensible and bewildering to observers. The strong, visible appearance of young Egyptian women going to college dressed in a manner unfamiliar to their own parents, completely “veiled” from head to toe, sometimes covering the face and hands as well, disturbed many. Some young women had switched almost overnight from wearing sleeveless dresses and miniskirts to becoming a “veiled” doctor, engineer, or pharmacist. Confused observers speculated about the cause. Was it an identity crisis, a version of America’s hippie movement, a fad, a youth protest, an ideological vacuum, an individual psychic disturbance, a life-crisis, a social dislocation, or protest against authority?

### Dress Code

The contemporary dress code translates materially this way: men and women wear full-length *gallabiyyas*, loose-fitting to conceal body form, in solid or otherwise aus-

tere colors made out of opaque fabric. The wearers lower their gaze in cross-sex encounters and refrain from body or dress adornment that draws attention to their bodies. The dress code for men consists of sandals, baggy trousers with loose-top shirts in off-white or, alternatively (and preferably) a long, loose white *gallabiyya* and a white or red-checked *kufiyya*. They grew a *libya* (full beard trimmed short). Women wear the hijab, which consists of *al-jilbab* (ankle-length, long-sleeved, loose-fitted dress) and *al-khimar*, a head covering that covers the hair and extends low to the forehead, comes under the chin to conceal the neck and falls down over the chest and back. During the first decade of the movement, women wore solid colors such as beige, brown, navy, burgundy, or black. The *mubajjabat* (women wearing hijab) engaged fully in daily affairs and public life. That is, austerity in dress and reserve in public behavior are not accompanied by withdrawal or seclusion and neither communicates deference nor sexual shame. Modern hijab is about sanctity, reserve, and privacy.

### Colonialism and Resistance

The role of the veil in liberating Algeria from French colonial occupation is popularly known. When the French landed in Algeria in 1830 most inhabitants were Arabic-speaking Sunni Muslims, with a large Berber population that was by then bilingual Berber Arabic speaking. Administratively, Algeria was a France populated by “the Muslims”—a majority of second-class citizens. France began a gallicization process on many fronts: French law was imposed on Islamic law, French social plan was imposed on local custom, French education substituted for Arab education, and the French language replaced Arabic. Many Algerians were excluded from education altogether. The French conquest of Algeria represented a deformation of the social, moral, legal, and cultural order. Economically the French monopolized the best land and the top jobs, exploited labor, harnessed local energies, and cultivated crops for French consumption (grapes for wine) while violating Islamic morality. Another strategy was to assimilate upper-class Algerians by gallicizing the woman and uprooting her from her culture. The target of the colonial strategy became to persuade the Muslim woman to unveil. Thus, Arabs and Muslims often link the deveiling of Muslim women with a colonial strategy to undermine and destroy their culture. The effect was the opposite: it strengthened the attachment to the veil as a national and cultural symbol, and gave it a new vitality.

Since 1948 Palestinian women who were uprooted from their homeland, particularly the older ones, wore a dress and head covering that communicated their rural origins and their contemporary status in refugee camps. After the 1967 Six-Day War, women wore white or black shawls (*shasha*) and had no access to their traditional fabrics and tools to embroider their clothing. In the late 1970s, as militant Islamic consciousness began to arise,

Palestinians attempted to restore the hijab. Women affiliated with the movement began wearing long, tailored overcoats and head covers now known as *shari'a* or Islamic dress. As in Egypt, the Islamic dress had no precedent in indigenous Palestinian sartorial history, but is an innovative tradition in form and meaning.

### Conclusion

The hijab worn by Muslim women in Arab, Muslim, European, or United States society is largely about identity, about privacy of space and body. In specific social settings, veiling communicates exclusivity of rank and nuances in kinship, status, and behavior and also symbolizes an element of power and autonomy and functions as a vehicle for resistance.

Hijab in the early twenty-first century is politically charged in France and Belgium, countries that are taking measures to ban the wearing of headscarves (hijab) to schools purportedly for maintaining the integrity of secularism, but the issue is considered to be fraught with anti-Islamic implications. To many young women the hijab represents an identity of choice and a freedom of expression they do not want to lose.

See also **Burqa; Djellaba; Islamic Dress, Contemporary; Jilbab; Kaffiyeh; Middle East: History of Islamic Dress.**

### BIBLIOGRAPHY

Sha'rawi, Huda. *Huda Sharawi: Muthakkirat Ta'idat al-Mar'a al-Arabiyya al-Hadiith* (Memoirs of Huda Shawari, Leader of Modern Arab Women). Introduction by Amina al-Said. Kitab al-Hilal, Silsilah Shahriyya. Cairo: Dar al-Hillal, 1981. In Arabic.

*Fadwa El Guindi*

**HILFIGER, TOMMY** The ubiquity of Tommy Hilfiger's fashions, particularly among urban youth, is a testament to the marketing and image branding that has characterized contemporary American fashion. Hilfiger was born in 1952, one of nine children raised by a jeweler and nurse in upstate New York; he described his childhood in his 1997 stylebook, *All American*, as living in "Leave it to Beaver-land" (p. 2). In his senior year of high school Hilfiger and two friends opened People's Place, a clothing shop in their hometown of Elmira that sold candles and bell-bottom jeans; Hilfiger enjoyed decorating the windows and designing in-store merchandise displays. People's Place thrived for nearly eight years, with additional stores opening in other towns, until it went bankrupt in the late 1970s.

In 1980 Hilfiger moved to New York City to pursue a career in fashion. He had a brief stint designing for Jordache jeans before joining forces with a woman's clothing manufacturer and starting 20th Century Survival, a junior-sportswear company that offered a variety of clothes in western and nautical styles, as well as Vic-

toriana dresses, khakis, and camouflage gear. In the mid-1980s Hilfiger contemplated job offers from Perry Ellis and Calvin Klein but instead accepted an offer from Mohan Murjani of Murjani International (the clothing manufacturer behind the fame of Gloria Vanderbilt jeans) to fund his own men's wear company. Murjani was looking to create a "name" designer like Calvin Klein and Ralph Lauren, and in 1985 Tommy Hilfiger was launched.

The building of Tommy Hilfiger was as much about marketing as it was about the clothes. Hilfiger embodied this approach, referring to himself in a 1986 *New York Times* article as a "natural, all-American-looking, promotable type of person with the right charisma. . . . I'm a marketing vehicle" (Belkin p. D1). Shortly after the debut of his first collection of preppy classics like chinos, oxford shirts, and polo knit tops and the opening of his Manhattan flagship store on Columbus Avenue, Murjani boldly put Hilfiger's name in lights. A billboard in Times Square read, "The 4 Great American Designers for Men Are: R—L—, P—E—, C—K—, and T—H—," referring to Ralph Lauren, Perry Ellis, Calvin Klein, and Hilfiger. Hilfiger's name did not appear in the ad, just his red, white, and blue flag logo and the address of his newly opened store. A 1987 advertising campaign for Tommy Hilfiger polo knit shirts pictured the Lacoste alligator, the Lauren polo player, and the Hilfiger flag logo type.

From the outset Hilfiger has been compared to Ralph Lauren. He has been criticized for copying Lauren's preppy style but gearing his signature red, white, and blue styles toward a younger market at more popular prices. Hilfiger, like Lauren, has appeared in advertisements for his clothing line; both men have used the American flag as an important marketing tool. Hilfiger has also replicated Lauren's business model, even employing former Lauren executives to help build Tommy Hilfiger, which Hilfiger, with backing from Silas Chou and Laurence Stoll of Novel Enterprises, bought from Murjani in 1989; Chou and Stoll then incorporated Tommy Hilfiger in Hong Kong. Following Lauren's lead in "lifestyle merchandising," Hilfiger expanded his franchise by opening a number of stores whose interiors reflect the all-Americanness of his clothing; by signing licensing agreements around the world; and by offering a range of lines, such as underclothing, accessories, fragrances, home décor, designer jeans, women's wear, children's wear, and a higher-end men's wear collection. Hilfiger spent \$15 million in advertising to launch his men's fragrance "tommy" in 1995, which, at the time, was the most money spent on a campaign for men's fragrance.

Unlike Lauren and other big-name American designers, Hilfiger tapped into hip-hop street styles, making him one of the hippest and wealthiest designers of the 1990s. Hilfiger had always been interested in music, and he saw the potential for musicians to dictate fashion trends. He sponsored a Pete Townsend tour; designed stage costumes for Mick Jagger and Sheryl Crow, among



others; and wrote the 1999 book *Rock Style: How Fashion Moves to Music* to accompany an exhibition cosponsored by the Costume Institute of the Metropolitan Museum of Art and the Rock and Roll Hall of Fame and Museum. However, Hilfiger's biggest coup in the music world occurred in 1994 when the rapper Snoop Doggy Dogg appeared on *Saturday Night Live* wearing a rugby shirt with the word "Hilfiger" running down the sleeve, which Hilfiger's brother Andrew had given the musician; the shirt sold out the next day at many New York department stores. Andrew, who worked in the music industry, acted as a goodwill ambassador for Tommy, handing out logo-embazoned shirts and bags to musicians when he arrived on sets for concerts and music videos.

Hilfiger's logo-laden street styles of the 1990s came about after he saw that counterfeiters were knocking off logos, enlarging them, and sporting them on oversized shirts, sweatshirts, and outerwear; they looked like walking advertisements. He also realized the huge possibilities in the status-symbol-conscious hip-hop movement that revolutionized the music scene in the 1990s. Hilfiger made regular in-store appearances, learning what young consumers wanted. Multiculturalism played a big part in his advertising campaigns; he employed stylists from hip-hop record labels, such as Rashida Jones, to appear in his ads and style his runway shows, which often featured such rappers as Treach, who mentioned Hilfiger in their songs.

In 1995 his once skeptical peers recognized Hilfiger with the Menswear Designer of the Year Award from the Council of Fashion Designers of America. Hilfiger made a name for himself by prominently putting his name and logo on his clothes and marketing them to urban youth in a way that other American designers had not done. He harnessed a diverse following of consumers with his oversized, street-style sportswear and his relaxed, all-American style of jeans, khakis, and polos that fit into the more casual approach to dressing that began to be taken at the end of the twentieth century. Hilfiger invested a great deal in advertising to keep his name and logo prominent; his packaging of the product has surpassed any originality in the clothes themselves. He has raised the bar for the fashion merchandising and image branding that have come to define American fashion.

See also **Fashion Advertising; Fashion Marketing and Merchandising; Hip-hop Fashion; Logos; Music and Fashion.**

#### BIBLIOGRAPHY

- Agins, Teri. *The End of Fashion: The Mass Marketing of the Clothing Business*. New York: William Morrow, 1999.
- Belkin, Lisa. "Big Campaign for Hilfiger." *New York Times*, 18 March 1986.
- Collins, Glen. "Campaign for Fragrance Plans to Assure That Men See It, Hear It, Sniff It." *New York Times*, 18 May 1995.
- Hilfiger, Tommy. *Rock Style: How Fashion Moves to Music*. New York: Universe Publishing, 1999.

Hilfiger, Tommy, with David A. Keeps. *All-American: A Style Book*. New York: Universe Publishing, 1997.

McDowell, Colin. *Fashion Today*. London: Phaidon Press Ltd., 2000.

White, Constance. "The Hip-Hop Challenge: Longevity." *New York Times*, 3 September 1996.

———. "If It Sings, Wear It: The Hilfiger Ploy." *New York Times*, 26 October 1997.

Tiffany Webber-Hanchett

**HIP-HOP FASHION** Hip-hop is both the voice of alienated, frustrated youth and a multibillion-dollar cultural industry packaged and marketed on a global scale. Hip-hop is also a multifaceted subculture that transcends many of the popular characterizations used to describe other music-led youth cultures. One of the important considerations about hip-hop is that since its conception in the early 1970s, hip-hop has arguably become more potent and efficient in galvanizing black social identity than the civil rights movement of the 1960s.

The evolution of hip-hop has developed from a self-conscious rumination of words and music to an obstinate expression of contemporary urban life through corporal gestures and apparel. From the beginning, hip-hop fashion has been on a trajectory of relentless flowering. Developments have been primarily in the men's wear sector; early clothes were functional and included conventional items—multicolored appliqué leather jackets, sheepskin coats, car coats, straight leg corduroy or denim jeans, hooded sweatshirts, athletic warm-up pants, mock turtle-necks, and sneakers and caps. Less functional items included designer jeans and moniker belts, gold jewelry, Kangol caps, Pumas with fat laces, basketball shoes, and oversized spectacles by Cazal.

Baggy apparel shapes that disguise the contours of the body were introduced in the 1980s. During the early 2000s, the archetypal hip-hop look consisted of baseball caps emblazoned with insignia from the Negro leagues and football teams and well-known fashion designers. Woolen beanie hats and bandannas were worn singularly or together. Goose down jackets or other foul-weather outerwear teamed with hooded sweatshirts. During the late 1990s the ubiquitous oversized white T-shirt, basketball vests, and hockey shirts became staples of the expression. Baggy denim jeans or camouflage cargo pants worn in a low-slung manner, backpacks, combat- or hiking-styled boots or sports shoes were complemented with tattoos and shaved, plaited, or dreadlocked hairstyles. Initially hip-hop women's wear consisted of inconsequential looks that reflected contemporary women's wear and were accompanied with items such as Gloria Vanderbilt jeans, bamboo earrings, Fendi and Louis Vuitton handbags, name chains, midriff tops, bra tops, short skirts, tight jeans, high boots, straight hair weaves and braids, tattoos, and false fingernails and oversized gold jewelry. In addi-

tion, some women wore apparel that consisted of items similar to those worn by men during the 1990s. Female rappers such as Lil' Kim and Foxy Brown displayed provocative apparel and outlandish sexual gesturing that would eventually become a *raison d'être* for hip-hop women's wear.

From within the postindustrial environment, hip-hop has emerged as an articulation of an affirmative "otherness," which is at times unpopular and misunderstood by politically conservative and socially moralistic groups, and especially by those who regard the modernist, anti-pluralist perspective to be sacrosanct.

Consequently, hip-hop tends to be unpopular with establishment agencies who wish to censor the expression and supervise the conduct and morals of the young; however, hip-hop is understood by mass media agencies and is exploited as a symptom of the volatility between the pull of materialism and the stagnancy of the urban underclass. The precarious state of this condition forces hip-hop to become a project concerned with the mastery of urban survival, and therefore has a global appeal that is demonstrated in hip-hop from New Zealand, Japan, Africa, France, and Great Britain.

A centrifugal force, hip-hop has contributed to the conceptualization of an alternative perspective in the wider society; this includes materialism, manners, morals, gender politics, language, gesture, music, dance, art, and fashion. Hip-hop music and fashion have attained an essential position in culture, though they oscillate on the periphery of conformity and general acceptability, but because of the notion of outsider status, and building upon the popularity of rock music, hip-hop has been admired and emulated by teenagers of most ethnicities and social classes.

### Where Hip-hop Began

Hip-hop has at times become synonymous with a constellation of products in the luxury goods market, though such a situation would have been absurd at hip-hop's genesis. Hip-hop was formed in the culture of the basement parties that took place in the Bronx in New York City. These parties became formalized when the DJs Kool Herc, Grandmaster Flash, and DJ Starski began to play at impromptu parties in parks, streets, and community centers. Jamaican DJ Kool Herc, the credited founder of hip-hop break-beats based his Herculords discotheque system on the Jamaican reggae sound systems that played in Jamaica and New York. The art form of rapping emerged as the way of communicating narrative to the audience. Rapping is similar to "toasting," a long-established feature of reggae music.

Toasting and rapping are delivered in the style of the African oral tradition. The DJ, or toaster in Dancehall, and the MC, or rapper, in hip-hop are the progeny of the African griot (storyteller), each offering a narration of everyday events.



### A NEW YORK HOME BOY IN THE MID-1990s

The wearer is dressed in iconic mainstream American classics, a white T-shirt, and Levi's 501 jeans. Either he is ignorant of that or his other clothes and the way he wears them are chosen to offset their status: Kangol golf hat, Nike sneakers, and the ubiquitous boxer shorts.

However, the key device of the display is achieved in wearing boxer shorts with jeans in a manner that the elastic edge of the boxer shorts peeps over the jeans waist causing the designer branded elastic to be visible. As a consequence the jeans are restructured, to the extent that the form of the pants begins to affect the wearer's stride. Bundles of fabric collect around the lower legs, causing bulk and restrictive movement. This precarious way of wearing jeans creates the foundation for the expression.

It is from rap and music video that followers are able to determine and validate their assumptions about their lifestyle decisions, including apparel expressions. Followers of hip-hop have created apparel expressions that are comparable to the utterances of hip-hop music. Hip-hop fashions reflect the energy and resonance of the urban experience while omitting illusory signs that demonstrate the metamorphosis of the subaltern individual into street luminary.

### Influence on Other Styles

"B-boy" and "Flyboy" were designations used to differentiate those focused on music and dance, and those who were focused on fashion. B-boys and B-girls were the former, and Flyboys and Flygirls the latter. B-boys have derived their designation from break-dancing. Break dancers dressed in sportswear like Puma sneakers, Adidas track pants, T-shirts, and padded nylon or leather jackets. They specialized in making poetic, gravity-defying acrobatic and explosive body-popping movements to the accompaniment of the interrupted, repeated, and overlaid phrasing of break-beat recordings.

The subtrends that followed break-dancing became the forerunners to rap-influenced fashion. For example, there are direct correlations to the fashion associated with hardcore rap, gangsta rap, and Afrocentric/cultural rap.

The B-boy expression has successfully crossed the subcultural divide. Skate boarders, who are predominantly white, also embraced much of the B-boy expression and have adapted it for their lifestyles. The Daisy Agers were exemplified by rappers De La Soul, who drew



**Rap star Lil' Kim wearing Chanel clothing and hat.** With hip-hop fashion a booming industry, many manufacturers are attempting to cash in, often using hip-hop personalities as spokespeople. © PACE GREGORY/CORBIS. REPRODUCED BY PERMISSION.

on the Afrocentric characteristics demonstrated by various black consciousness movements since the 1960s. Neo-Panthers, Afrocentrics, Sportifs, and Gangstas represent developments that enjoyed widespread followings. Indeed these characterizations contain apparel objects that demonstrate complicity in virtually every diaspora expression since hip-hop defined itself during the early 1980s. Many of the fashion objects utilized by the 1980s B-boy were affirmations of the pre-1980s. Much of the gangsta expression borrowed from the 1970s pimp style, while the mid-1980s look of the archetypal B-boy fused a Black Panther aesthetic with a sportswear look flavored by Jamaican Rude *Bwoys*. B-boys and Flyboys have succeeded as a result of the intercultural exchange between “the cultural imperatives of African-American and Caribbean history and identity” (Rose p. 21).

During the mid-1980s and early 1990s, hip-hop fashion gathered importance as hip-hop music became successful around the world. As a consequence, B-boys are no longer black and working class.

The genesis of fashion hip-hop had been skillfully articulated by the B-boys of the 1970s who created a path for subsequent hip-hop groupings (Daisy Agers, New Jaks, Sportifs, Nationalist [neo-Panthers]), who all added their own unique expressions to the fashion. As unofficial designers, such groups breached and corrupted many of the extant propositions about fashion and provided the template that a new generation of hip-hop fashion wearers should have committed. Like hip-hop music, hip-hop fashion edits, samples, repeats, unites, and creates new fashions—sometimes from nonsense and sometimes from deep-felt sentiment that defines the bona fide experiences of hip-hop wearers. In many instances B-boys are found to have enthusiasm for mainstream fashion labels. A feature of hip-hop fashion expressions is a predilection for American, Italian, and English designer labels such as Tommy Hilfiger, Ralph Lauren, Gucci, and Burberry. For the B-boy, consumption of clothes is part of a rite of consumption and exhibition which reaffirms the formula, “I am = what I have and what I consume” (Fromm p. 36).

The overstated stylization of the B-boy is articulated in humorous, exaggerated, and outlandish clothes that are sometimes similar to an animated cartoon character. This visual aesthetic replaces and dispels any idea that alienation renders individuals invisible. The “standardized” version of hip-hop fashions has become locked into parody. During the 1980s, fashion labels became ensconced in hip-hop culture. The adoption of counterfeit Gucci and Fendi apparel and bona fide Nikes and Timberlands represented attempts to create fashion that has resonance beyond the context of hip-hop community.

During the 1980s, the Harlem store Dapper Dan became renowned for the idea of exalting “exotic” conspicuous fashion labels such as Fendi and Gucci. Much of the appeal to consumers was in the distillation of the logotypes of these high fashion brands on to *their* clothing and on to the streets of Harlem. Typically, fabric printed with the logotypes of these brands would be made into apparel that would not be found in the bona fide collections of Fendi or Gucci. Ultimately Dapper Dan was a postmodern project that included the development of hip-hop fashion.

### Designers and Producers

In part, hip-hop fashion came about by default. Designers of active sportswear and sports shoes did not target the streets, nightclubs, or music videos as the primary location for their products. In particular, branded sportswear such as Adidas, Reebok, Nike, and British Knights had been appropriated by hip-hop and became precursors to the dedicated fashion sportswear hip-hop brands of Troop, Cross Colors, Mecca, Walker Wear, and Karl Kani. However, apparel companies have never surpassed the preeminence of the sportswear shoe brand. Nike and Adidas sneakers are indicators of hip-hop’s distance from the mainstream; for many wearers the sneaker and the



Nike Swoosh were potent objects in the urban rite of passage. Nike Air Force 1s and Air Jordans became iconic and fetishistic. The Nike logotype has been worn as jewelry, cut into hair, and tattooed onto skin.

Hip-hop has created its own trends and consumption patterns, with cultural networks that mutate at an intimidating rate. Its collusion with mainstream fashion is well established. Many of the raps by major hip-hop stars exalt the importance of wearing Gucci, Prada, Versace, Tommy, Earl, Burberry, Timberland, Coogi, and Coach. Such raps are usually arrogant brags condoning one-upmanship such as Lil' Kim's request on her song "Drugs" on the album *Hardcore*, "Call us the Gabbana girls, we dangerous, bitches pay a fee just to hang with us" or "Yes indeed, flows first class and yours is coach like the bag, the Prada mama."

Motifs, fabrics, color, and the drama of wearing apparel dramatically altered during 1998 when hip-hop leaders began to recognize the mainstream fashion quartet of Versace, Prada, Dolce & Gabbana, and Gucci as the ultimate in fashion expression. The materialist focus set by the hip-hop gangstas, players, and hip-hop celebrities populated the idea of "ghetto fabulousness" (the juxtaposition of "fabulously" expensive objects placed in the context of the impoverished ghetto) as a replacement for hip-hop fashions that did not rely upon endorsements of glamorous and expensive mainstream fashion brands.

Such new inflections prompted another revision of hip-hop fashion. Although branded performance sportswear was initially popular in hip-hop culture, its displacement was prompted when Lil' Kim—among other hip-hop stars—used important designer labels to create an image of privilege and status. Ordinary hip-hop fans and fashion companies alike understood this idea. The raps of Lil' Kim and other rappers have injected retail, advertising, and promotion strategies of fashion companies with a new thematic source and a previously unexploited marketplace. Hip-hop fashion represents a subversive discourse; fashion companies recognize this standpoint as being favorable if they wish to affect values and attitudes that are urban and therefore cool. However, some companies fail in this ambition and have all suffered from "myths" about consumers that are "incompatible" with the companies branding.

In their attempts to achieve postmodern relevance, fashion companies such as Asprey, Puma, Versace, and Iceberg have used the formal recommendation offered in strategies of cross-marketing. This can range from a celebrity appearing in an advertising campaign or just sitting in the front row of a designer's runway show.

To counter this, a number of hip-hop music moguls—Russell Simmons, P. Diddy, and Master P—have all owned apparel companies. Their companies produce creative fashion collections that are synchronized with the musical output of their recording enterprises. These companies separate into those that follow an ac-

curate rendition of hip-hop fashion and those companies that seek to cross over and produce designs that have broad mass fashion appeal rather than a specialist hip-hop appeal.

In attempting to model the direction and content of hip-hop fashion, hip-hop's moguls have disregarded the life experiences, economic means, and self-creative tendencies of hip-hop followers in favor of a personal ideology.

### How Hip-hop Crosses Boundaries

In the early 1990s, a group of Brooklyn hip-hop followers began to reuse Ralph Lauren garment labels, and to sew them on apparel not made by Ralph Lauren. The action of the Lo-lifer subculture was to challenge the commercially aggressive opposition of Ralph Lauren and to counteract the "antagonism" of the fashion label. The deconstruction of the fashion company's well-maintained branded image creates a reversal in hierarchy. When Ralph Lauren's Polo label is hand-painted onto a wall, or even a towel, as the Lo-lifers did, a question is asked about commercial branding and the mythological representation of the fashion logotype.

A characteristic of hip-hop fashion is the multiple themes that are filtered through the aspirations of wearers and designers alike. The American mainstream designer Tommy Hilfiger has successfully captured an understanding of hip-hop culture and has produced very specific fashion items, which fit the market place without being apologetic.

During the mid-1990s, new cuts of Hilfiger's jeans were given titles such as "Uptown," which refer to the geographical placements of Harlem and the Bronx, two New York districts with large African American populations. The Uptown cut of the jeans are ostensibly the same as extra-baggy, low-slung jeans manufactured by any other hip-hop designer or popular mainstream manufacturer addressing the hip-hop marketplace; however, the degree of hip-hop enthusiasm for Hilfiger made the brand very popular.

Hip-hop fashion is regarded as a delineator of "cool." Indeed aspects of hip-hop have become the characterization of dissonance; that is why British royal princes William and Harry were happy to adopt homeboy gestures while wearing baseball caps. Probably having never met a real live B-boy, cool gesturing postures are no doubt gleaned from music videos.

In one of the most informative studies of the cool expression, Majors and Billson suggest that cool adds value to the disenfranchisement of the individual. Its practice is constructed through attitude and implies status for the wearer through an attributed importance of fashion objects. The phenomenon of cool emerges as the compelling ingredient to hip-hop life; it is effected by the attachments of self. Cool, or to use other evocations, "fly" or—in Britain—"styling it out" is a creative procedure of

## HIPPIE STYLE

stealth serving as a badge of belonging, though it allows wearers the scope to make minor adjustments to their apparel configuration.

See also **Hilfiger, Tommy; Lauren, Ralph; Music and Fashion.**

### BIBLIOGRAPHY

- Fricke, Jim, and Ahearn Charlie. *Yes, Yes, Y'all: The Experience Music Project Oral History of Hip-Hop's First Decade*. Cambridge, Mass., Da Capo Press, 2002.
- Fromm, Erich. *To Have or to Be?* New York: HarperCollins Publishers, Inc., 1976.
- Lil' Kim. "Drugs." *Hardcore*. (Sound recording.) New York: Undeas/Big Beat, 1996.
- Lusane, Clarence. "Rap, Race and Politics." *Race and Class: A Journal for Black and Third World Liberation* 35, no. 1 (July–September 1993): 41–56.
- Majors, Richard, and Janet Mancini Billson. *Cool Pose: The Dilemmas of Black Manhood in America*. New York: Touchstone Books, 1993.
- Perkins, William Eric, ed. *Droppin' Science: Critical Essays on Rap Music and Hip Hop Culture*. Philadelphia: Temple University Press, 1995.
- Rose, Tricia. *Black Noise: Rap Music and Black Culture in Contemporary America*. Middletown, Conn.: Wesleyan University Press, 1994.

*Van Dyk Lewis*

**HIPPIE STYLE** In the mid-1960s, the hippies—the rebels and dropouts of the Haight-Ashbury community of San Francisco—generated one of the most influential of history's dress reform movements. Their style was so outrageous and anomalous that it alone could have made the hippie movement impossible to ignore. As did their lifestyles, their fashion built upon San Francisco and California's tradition of iconoclasm; important, too, was the precedent provided by the young ready-to-wear designers of London, whose international impact began in the late 1950s.

The hippies' protest against capitalist society informed their impunity to all received strictures or etiquettes about clothes. They coordinated garments so that harmonies and homogeneity were fractured. Mad, anarchic *mélanges* resulted. They simulated acid phantasmagoria in their color schemes and paraded recycled old clothes, proclaiming them not as cast-off rags but proudly worn pedigree. They disguised and revealed themselves in costumes that were avatars of theatrical or historical or mythological identities, rather than the easily legible roles recognized by contemporary society. Their clothes were a paean to sexuality and sensuality: texture and tactility were foregrounded in their favorite fabrics, which ranged from slinky satin and stretch to all variety of embroidered and figured surfaces. Sometimes their fashion became not a second skin, but the exposure of their own nude bodies, painted and pat-

terned in tribal fashion; this was a celebration of instinctual expression that they believed had been obliterated by industrialization.

### Ecological Fashion

The hippies built on the generic silhouettes that prevailed during the 1960s—the miniskirt, the pantsuit—but they transmogrified Mod fashion at the decade's midpoint by the way they put their clothes together, by their choices of fabric, and by the way they accessorized. Folkloric motifs, style, and fabrics were ubiquitous in hippie fashion. Their adoption of long peasant skirts helped move fashion back to longer hemlines. The generally loose and unconstructed silhouette of the 1960s became even more flowing with the adoption of mideastern tent shapes. The hippies' infatuation with the ensembles of Native Americans demonstrated solidarity with their plight as well as well an aesthetic appreciation.

Another prong of hippie fashion likewise proclaimed common cause with the workers of the world: this was the utilitarian fare that came to be known as "anti-fashion." It was fashion at its least overly decorative, most rugged, and basic: blue jeans worn with T-shirts, work shirts, and other commonplace attire. Decorative appeal was provided instead by the contours outlined by these body-clinging garments. Thus the youthful counterculture promulgated an allure that could not be achieved by expenditure alone.

The hippies generated an ecological consciousness of fashion by their recycling of vintage clothes as well as their cannibalizing of old fabrics and hangings, out of which they cut new garments. They drew attention to the way that all clothes costume the wearer into roles, some—businessman, housewife—so integrated into the warp of society that they were no longer recognized as constructed characterization. Their pacific appropriation of military uniform likewise showed a determination to mock and denature the pieties vented by the opposite side of the ideological divide.

Los Angeles, New York, and London also became important citadels for hippie fashion. On Los Angeles's Sunset Boulevard and in New York's Greenwich Village were clustered constellations of independent boutiques. London's contribution to hippie fashion was indebted to the art and crafts movement of a century earlier. More than San Francisco, the city's secondhand clothes stores and bazaars were more likely to be filled with heirloom couture. London raided its storage vaults, disgorging into the city's auction house fabulous caches of vintage clothing as well as theatrical and ballet costumes.

### The Rich Hippies

"We got pretty scathing about store-bought hip that didn't come from the soul," said Linda Gravenites (interview with the author, November 1986), who made clothes for many residents in the Haight-Ashbury com-

munity and the rock bands based there. Nevertheless the purists or the ideologues were powerless to stop the inevitable co-opting, the proliferation of hippie fashion within the mainstream fashion industry. From 1967 to 1971, the hippie's fashion was grist for the couture and upscale ready-to-wear mills. The "rich hippie" look upgraded hippie style into fabrics that were largely well beyond the economic reaches of the financially marginal denizens of Haight-Ashbury.

The fashion of the hippies was as much threat as influence to the fashion establishment. The hippie's open-ended pluralism threw down the gauntlet to the seasonable revisions proffered to women by the mainstream fashion industry. Savoring vintage garments established a continuum between past and present, a rejoinder to the forced amnesia of customers told that each year marked a *tabula rasa* of consumption.

Perhaps what above all made hippie fashion so subversive to the mainstream industry was its tacit message that the time had come to abolish the fashion designer. It resonated as well with the burgeoning women's liberation movement: women would no longer be told what to wear by a designer, who was usually male. After Rudi Gernreich decided to close his ready-to-wear business in 1968, he told reporters that he was now disenchanted by clothes that bore the imprint of the individual designer. The very act of designing, in fact, seemed to him to be an *a priori* dictate that no longer fit the needs and aspirations of the clothes-wearing public.

With every question of identity in Western civilization of the late 1960s being debated, fashion exploded with costume and fantasy, thanks in large part to the inspiration provided by the hippies. "Today nothing is out, because everything is in," Marshall McLuhan wrote in 1968. "Every costume from every era is now available to everyone." (*Harper's Bazaar*, April 1968, p. 164)

Hippie fashion continued to steep throughout fashion during the 1970s. Even as fashion retreated from the utopian threshold advanced during the late 1960s, the hippies' ideas were disseminated to many more people than they had been during the 1960s. By the end of the decade, it seemed to have become exhausted. But since the mid-1980s, hippie style has enthralled designers and the public again and again, becoming a recurrent influence in every echelon of fashion.

See also **Music and Fashion; Politics and Fashion; Social Class and Clothing.**

#### BIBLIOGRAPHY

- Lobenthal, Joel. *Radical Rags: Fashions of the Sixties*. New York: Abbeville Press, 1990.
- Reich, Charles A. *The Greening of America: How the Youth Revolution Is Trying to Make America Livable*. New York: Random House, 1970.

Joel Lobenthal

## HISTORICISM AND HISTORICAL REVIVAL

Prior to the rise of the bourgeoisie, historical revivals in dress were the preserve of the aristocratic classes, principally employed as costume either for masquerade and pageantry, portraiture or professional function (courtly and legal uniform), and always as a distinguishing mark of timelessness and status—of both power and beauty.

From the sixteenth to eighteenth centuries, fashions in the choice of historical focus were mainly informed by divisions between town (the urban powerful) and country (the Arcadian idyllic), and received ideas of morality and immorality. The meaning and embodiment of the latter coupling shifted most frequently—morality at some stages implied by Anglo-Saxon mythologies of status and structure. The body coverings most frequently represented by fashions were crinolines, hoops, bustles, and corsetry for women, and armor and padded upper bodies for men. In turn, however, the looser costume of Greco-Roman mythology and the reverence for the ideal physique, and the beauty of nature that they represented, were also held up as archetypes of morality in different periods—although they were usually quite swiftly decried for their immorality in openly revealing the female body. As with all the revivals to follow, these trends were rarely based on historical accuracy, relying primarily on a nostalgic imagination and secondhand source material.

### Gothic

The original fifteenth-century Gothic dress for women combined thirteenth-century ideals of fitness for purpose and an ecclesiastical sensibility (headdresses in particular bore direct reference to the wimple) with beauty of line and sumptuous fabrics (velvets and brocades). Gothic revivalism was already taking place in the mid-seventeenth century (the Puritans drew on the religious overtones of the Gothic in the face of Royalist decadence), and was popularized again in the mid-eighteenth century as a decorative and architectural movement (Gothick), its leading proponents including Batty Langley (1696–1751) and Horace Walpole, whose Strawberry Hill project (1750–1770) came to epitomize the period. The eighteenth-century revival was a movement driven by romance, and one that stood against the perceived rigidity and rules of the classical style; the medieval appeared more natural, fantastical, and foreign compared to the worlds of Greece or Rome. In dress, its expression was principally neomedieval, somber in tone and concentrated on flat, embroidered pattern on sleeve and bodice panels. It was notoriously inaccurate and widely ridiculed until the 1830s when A.W. N. Pugin (1812–1852) proposed an accurate and faithful return to Gothic style as a nationalist, moral, and spiritual bulwark in the face of advancing industrialization. Pugin's work heavily influenced the Victorian aesthetic and later, the flat printed pattern of William Morris (1834–1896) and the Arts and Crafts movement. In the late twentieth century, the Gothic style returned again as an addendum to punk,



drawing on but darkening the punk movement's oppositional stance and twisting the spiritual meaning of Gothic style to embody older, more mystical religions (such as Wicca, paganism, and Buddhism). But, as with previous Gothic revivals, 1980s' goths embraced the romanticism of the movement, combining the PVC and rubber of punk with the velvets and brocades of their eighteenth- and nineteenth-century predecessors.

### Neoclassicism

The taste for what became known as neoclassical style has its roots in the 1750s, emerging in opposition to the exoticism and opulence of the rococo (promoted by the launch of the Dilettanti Society in 1734 and the Society of Arts in 1754). Much of the literature (Rousseau) and painting (Gainsborough, Reynolds, and Hogarth) in the decades leading up to the neoclassical movement was directed toward proposing a romanticized classicism as a moral tendency linking the purity of nature with purity of spirit. It was possible for both the neoclassical and the Gothic to exist in much the same space, due both to the opening up of society to fashion and to the shared beliefs of each movement.

The movement achieved prominence in the 1780s and is most closely associated with Thomas Hope (1769–1831), whose *Costumes of the Ancients* (1809) and *Designs of Modern Costumes* (1812) were pivotal to popularizing the looser, unstructured Greco-Roman dress styles. Dresses were made principally from muslin with waistlines rising to the bust, which was still firmly secured by stays and highlighted by a sash and knotted scarf. The effect was naïve and childlike, best expressed in the popular 1880s' illustrations of Kate Greenaway. In keeping with antique statuary and notions of the ideal physique for men, tightly fitting breeches and cutaway jackets revealed more of the body.

Hope was also an exoticist and hosted Turkish-inspired parties at his home, similar to those favored by the Parisian designer Paul Poiret (1879–1944) in the early twentieth century. Poiret and two other designers of the period, Madeleine Vionnet (1876–1975) and Mariano Fortuny (1871–1949), were the principle players in the revival of the neoclassical in the 1920s and 1930s (also known as vogue gency).

### The Aesthetic Movement

As with neoclassicism, the aesthetic movement studied and celebrated beauty. The movement took hold in the United Kingdom in the 1870s. Its proponents in the decorative arts (William Morris), literature (Walter Pater, Charles Baudelaire, Oscar Wilde), and fine arts (James McNeill Whistler, Aubrey Beardsley, and the Pre-Raphaelite painters) proposed elegance in everything. Nature (flora, fauna, and the athletic human body) was eulogized in all its glory as the epitome of beauty, a manifestation of God on Earth. What separated Gothic and aesthetic was the latter's belief of "art for art's sake" as

shifts in understanding over the nature of morality gave rise to an intense dispute between the Philistines (art as a medium for social and moral purpose) and aesthetes (art as beauty and truth) that raged throughout the 1860s and 1870s.

The proponents of grace, athleticism, and activity for women had to wait for the Rational Dress Society, launched in 1881, to put forward their case. The Healthy and Artistic Dress Union swiftly followed it in 1889 pronouncing Victorian restraint unhygienic and spiritually detrimental. Women's clothing became looser, more opulent in texture and heavily influenced by medieval styling, folklore, fairytale, and Arthurian legend. The figure of woman as represented in painting was most commonly sleeping—a state of innocence and purity that also implied the awakening, or liberation (sartorial and sexual), into womanhood that was to follow in the fin de siècle era of decadence. The legacy of the aesthetic movement is most clearly seen in the artistic circles of the Bloomsbury Set in the early twentieth century and the hippie movement of the 1960s.

### Neo-Edwardianism

The Teddy boy (derived from the nickname of Edward VII) grew out of a sensibility fostered in post-World War II Britain that the shared hardships of war and rationing would result in a more egalitarian society (Polhemus, p. 34). The expectations of the young working class were manifested in the reworking of a neo-Edwardian style that had been pioneered by London's Savile Row tailors for their upper-class clients—single-breasted, long, and fitted jackets with velvet collars were worn with drainpipe trousers and brocaded waistcoats. Young men from the East End paired similar clothing with a cowboy's tie and the extravagant sentiments of American East Coast, black Zoot style. The adoption of these specific signifiers served to ally Britain's working classes simultaneously with the American Dream, and the outsiders who challenged it. In doing so, the Teds presented a challenge to establishment British society, particularly by subverting aristocratic dress codes, and this subcultural style served as blueprint for all the street style that followed in the latter half of the twentieth century.

### Retro

The fashion for retro styling had often left the industry open to accusations of moribund nostalgia. Both at street level—the Teds by the Edwardians, the mods by the Italians, glam-rock by the aesthetes, the casuals by the mods, the goths by the punks—and at the level of high design, the speed and influence of revivalism has increased incrementally over the last forty years, to the point that even futurism is retro. But critics ignore the importance of sociopolitical and cultural context in the process of selection. This is particularly apparent in high design. Walter Benjamin, in *Theses on the Philosophy of History*, speaks of the creative "tiger's leap" into the past, the aggressive

and specific selection of historical reference to serve contemporary comment. Historical revivalism is most often used as a tool to create a pervasive, and recognizable, environment for fashion that responds very pertinently to the times in which it is created. Arguably, there is nothing new to create, only creative ways of reinterpreting the past. As the designer John Galliano points out, “What’s modern? . . . Gucci? Or Prada? That’s just their interpretation of modern but it’s still an historical take. . . . I think reinterpreting things with today’s influences, today’s fabric technology is what it’s all about” (Frankel, p. 176).

See also **Aesthetic Dress; Goths; Retro Style.**

#### BIBLIOGRAPHY

- Burman Baines, Barbara. *Fashion Revivalism: From the Elizabethan Age to the Present Day*. London: B. T. Batsford, Ltd., 1981.
- Frankel, Susannah. *Visionaries: Interviews with Fashion Designers*. London: V and A Publications, 2001.
- Lambourne, Lionel. *The Aesthetic Movement*. London: Phaidon Press Ltd., 1996.
- Polhemus, Ted. *Fashion and Anti-Fashion: An Anthropology of Clothing and Adornment*. London: Thames and Hudson, Inc., 1978.

#### Internet Resource

- Benjamin, Walter. “Theses on the Concept of History.” Available from <<http://www.tasc.ac.uk/depart/media/staff/lb/WBenjamim/CONCEPT2.html>>.

Alice Cicolini

**HOLLYWOOD STYLE** In 1974, Diana Vreeland organized an exhibition at the Metropolitan Museum of Art, devoted to studio designs. The exhibition’s title, *Romantic and Glamorous: Hollywood Style*, sums up perfectly the way in which traditional “Hollywood style” is perceived. It is seen as synonymous with glamour and opulence. Vreeland emphasized this in the exhibition’s catalog: “Everything was larger than life. The diamonds were bigger, the furs were thicker and more luxurious . . . silks, satins, velvets and chiffons, miles and miles of ostrich feathers . . . everything was an exaggeration” (p. 5).

Certainly this is true of archetypal “Hollywood style.” But, arguably, there is another important factor—the way in which cinema can be used to sell most products and, in particular, to disseminate new fashions. As Charles Eckert argues, Hollywood gave consumerism its “distinctive bent”—it influenced the way men and women wanted to look, as well as the cars they chose to drive, and the cigarettes they decided to smoke. Gradually, this influence became globalized.

This potential power was not immediately perceived. However, as early as 1907 there was widespread public interest in the rumored disappearance of Florence

Lawrence, the “Biograph Girl.” A desire to know about the private lives and off-screen activities of the first identifiable stars was apparent at an early stage.

With the identification and growing popularity of stars such as Mary Pickford, Gloria Swanson, and Irene Castle before, during, and after World War I, women began to see the star “image” as something to emulate. During the radical sartorial changes that took place in the 1920s, Hollywood was a vital part of the process through which it became both desirable and socially acceptable for women to wear makeup, after a century of taboo. The carbon lighting of early films meant makeup was a necessity—pink cheeks became gray and skin bleached. Max Factor, a makeup artist for the Moscow State Theatre, arrived in Los Angeles in 1908, and by 1914 he had perfected a product called Supreme Greasepaint for all the studios, along with newly developed eye shadows and pencil liners. This product was packaged in a compact tube and manufactured in several colors, and in a very short time he was selling directly to the public, for it was the faces of the stars that had the most impact on the public at this early stage.

Clara Bow was the first star that women set out to imitate, copying her “Cupid’s bow” mouth and penciled brows. Furthermore, her bobbed hair made the new cuts desirable. Bow portrayed the sort of girl who, although unusually pretty, was not too far removed from the world of her female fans.

This kind of popularity with a female fan base meant that a star could popularize not one, but several fashions. Just as in the next decade Garbo would make berets, trench coats, and men’s pajamas simultaneously desirable, so Clara Bow persuaded women to shorten their skirts, bare their legs, and adopt the cloche hat, which had been in fashion for some time. And in 1928 Jean Harlow, the “Platinum Blonde,” prompted many women to experiment with peroxide; hence, safe home hair dyes were swiftly produced. Harlow also made a Paris fashion popular—the backless, bias-cut dress she wore in *Dinner at Eight* (1933) was instantly copied.

#### Retailing Tie-ins

Hollywood studios were beginning to appreciate their power. The studio system, which lasted until the 1950s, meant that stars and costume designers were under contract to a particular studio, which could profit from their work. The studios owned distribution rights in cinemas across America, and it was easy to export Hollywood films, first to Europe and later worldwide, despite the existence of national cinemas elsewhere. In the early 2000s, despite the vast size of the Hindi film industry, American cinema was still dominant.

The fashion industry had been swift to recognize the commercial possibilities of the cinema—in 1923 Salvatore Ferragamo, founder of the firm, provided every single pair of sandals for *The Ten Commandments*. Couture designers

became involved—Paul Poiret designed the clothes worn by Sarah Bernhardt in *Elizabeth I* (1912) and Sam Goldwyn lured Chanel to Hollywood. Meanwhile, the studios, becoming aware of the appeal of the costumes designed by Adrian and his peers, worked speedily to prevent unauthorized copying and to maximize profit.

In 1930 the Movie Merchandising Bureau was established, and Macy's had a Cinema Shop. During the 1930s different studios would issue their own licenses, so that by the end of the decade there were various different retail outlets within department stores across America. This was the age of the "tie-in," when promotional campaigns linked to particular films were highly successful—window displays featured not only clothes and accessories from a particular film but also other themed goods. *Queen Christina* (1933), for example, was used to promote "hostess gowns" and Swedish flatware.

The fan magazines were at the height of their popularity—and discussions raged in their pages. Dorothy Lamour conducted a dialogue with her fans as to whether or not she should make another "sarong" film. In fact, she would always be associated with this garment, designed for her by Edith Head—and now a wardrobe staple. At the same time, glossy magazines were debating the question of whether Hollywood could lead fashion, or merely follow Paris.

*Gone with the Wind* (1939) influenced bridal wear for decades—and it was suggested that Dior had the popularity of the film's costumes in mind when he created the New Look. The decade had also made lingerie an enormously profitable business through the slips, negligees, and marabou slippers seen on screen.

### The Postwar Period

The influence of Hollywood did not end in 1939—and included body shape. The busty stars of the 1950s meant enormous profits for the underwear industry, and Marilyn Monroe was arguably the most influential star of all time, as women sought the different components of her "look."

With the emulation of Marlon Brando and James Dean in the 1950s, and the gym culture, which resulted from the sight of well-muscled male bodies in the action pictures popular from the 1980s onward, it seems that men in the postwar period have been more influenced by Hollywood than ever before. Men's wear designers responded quickly, and continue to remain heavily involved. Ralph Lauren's designs for Robert Redford in *The Great Gatsby* (1974) were not as heavily covered in the press as his women's wear for Diane Keaton in *Annie Hall* (1977). However, it had been clearly demonstrated that a mainstream Hollywood film could be used to showcase clothes not unlike those in the designer's current ready-to-wear range, and Armani was the first to manipulate this opportunity by dressing Richard Gere for *American Gigolo* (1980); Cerruti followed his lead by dressing

Michael Douglas for a number of influential films in the 1980s, including *Wall Street* (1988). Much of what we wear is a legacy of Hollywood—trousers for women, tennis shoes for everyday, leather jackets, jeans, and T-shirts. Yet some designers were never convinced—Elsa Schiaparelli complained that Joan Crawford's shoulder pads were copied from her collections and that Adrian had simply stolen the concept. Vivienne Westwood's one foray into cinema—she designed the collection supposedly produced by Richard E. Grant in the box-office debacle *Prêt-à-Porter* (1995)—has obviously made some other designers wary of involvement. But attempts to use film as a way of presenting new ideas continue; Uma Thurman's yellow trainers for *Kill Bill* (2003) did not impress audiences, but Samuel L. Jackson's Kangol beret in the same hue, worn in *Jackie Brown* (1997) meant that their already buoyant sales figures virtually doubled.

See also **Actors and Actresses, Impact on Fashion; Film and Fashion.**

### BIBLIOGRAPHY

- Bruzzi, Stella. *Undressing Cinema: Clothing and Identity in the Movies*. London: Routledge, 1997.
- Eckert, Charles. "The Carole Lombard in Macy's Window." In *Fabrications: Costume and the Female Body*. Edited by Jane Gaines and Charlotte Herzog. London: Routledge, 1990.
- Fox, Patty. *Star Style: Hollywood Legends as Fashion Icons*. Santa Monica: Calif.: Angel City Press, 1999.
- Maeder, Edward. "Hollywood and Seventh Avenue." In his *Hollywood and History: Costume Design in Film*. Los Angeles: Thames and Hudson, Inc., 1987.

Pamela Church Gibson

**HOMESPUN** The word "homespun" connotes both a rough fabric worn by country people and the human qualities, good or bad, associated with it. In English literature, "homespun" can mean boorish behavior or wholesome simplicity. In Shakespeare's *Midsummer Night's Dream*, for example, Puck dismisses the comic bumpkins Bottom and Snout as "hempen homespun." Writing a century later, John Dryden contrasted "harlot-hunting" foreigners with an "honest homespun country Clown" of English make. In the eighteenth century, political writers on both sides of the Atlantic adopted the personae of a wise but plainspoken countryman or -woman, signing themselves "Dorothy Distaff" or "Horatio Homespun." In the nineteenth-century United States, poets, novelists, and preachers celebrated an idealized "age of homespun" that symbolized the virtues of self-sufficiency and egalitarian simplicity.

Because "homespun" had such a powerful literary existence, it is sometimes difficult to define its actual use in times past. Commercial production of cloth was well developed on the European continent and in Great Britain by the seventeenth century. Before industrialization, the opposite of homespun was not factory spun but market



spun. Most spinners did, in fact, spin in their own or their masters' homes, but merchant clothiers managed the steps in production. Spinning, weaving, and finishing sometimes took place in different regions or even in different countries, sometimes mixing wool from different colored sheep to produce the rough hodden, russet, or country gray that poets praised, but that fewer and fewer people actually wore.

In the earliest years of settlement, North American colonists had little incentive to spin. It made more sense to devote energy to developing crops for export. But as farms and plantations developed and as the population grew, more families began to raise sheep and sow flax for their own use. By the middle of the eighteenth century, in New England and in the Chesapeake, women took up weaving, an occupation that had belonged to men in commercial textile-producing areas of Europe. In Pennsylvania, high immigration from England, Scotland, and Germany kept looms in male hands. Rural families used locally made fabrics for towels, sheets, grain bags, everyday petticoats, work shirts, and aprons, but they were never self-sufficient. English woolens and Indian calico were prized for outer clothing, and in the plantation South, most slave clothing was still made from cheap imported linens like osnaburgs or from coarse Welsh woolens.

Homespun took on political connotations in the years leading up to the American Revolution. A writer in the 16 October 1769 *Boston Gazette* claimed that if "Hellen wrought the Fate of ancient Troy," then New England's daughters, through household industry, could "make us Blest and Free." As political leaders urged boycotts of British goods, New England women gathered in "spinning meetings" and southern planters like George Washington improved sheep herds and diverted some slave labor to spinning. Although true self-sufficiency was never a realistic possibility, the boycotts did for a time put pressure on Parliament.

Before a second war with England in 1812, a Rhode Island poet, nostalgic for revolutionary days, lamented in the 1 December 1810 (Providence) *Columbian Phoenix*:

There was a time—Columbia's gothic days—  
When maidens spun their wedding gowns and linen:  
But no, so tasty, so refin'd our ways—A homespun  
gown no wench will stick a pin in.  
The veriest dowdy now is too genteel,  
To waste a moment at the whirling wheel.

The poet was wrong in thinking American women had ever spun their "wedding gowns," though many women continued to spin a great deal of household linen, and newspapers once again reported patriotic spinning bees during this war.

The federal census of 1810 counted spinning wheels and yards of cloth as well as people. On average, Americans were making ten yards of cloth per capita, though the state averages ranged from twenty-eight yards in New Hampshire to five in Maryland and Delaware. The early

stages of industrialization actually stimulated household production. When water-powered carding mills assisted in the tedious task of preparing wool for spinning, housewives increased their output of spun yarn. They also learned to mix factory-spun cotton thread with homespun flax or wool. In much of the United States, though, household production declined rapidly after 1830. It persisted, however, in isolated pockets of the Northeast and South, in newly settled areas of the West, and in eastern Canada, where it was still an important part of the agricultural economy in 1870.

In the southern United States, homespun also had a brief revival during the Civil War. Again poets and politicians linked patriotism with female industry, as in the popular song "The Homespun Girl."

The homespun dress is plain, I know,  
My hat's palmetto, too;  
But then it shows what Southern girls  
For Southern rights will do.

Again, the mystique of homespun was probably more powerful than the reality. Women who already knew how to spin took their wheels out of the attic, but families with no prior experience found it difficult to take up cloth making. Furthermore, many white women refused to wear homemade fabric because it seemed too much like the rough “negro cloth” worn by slaves.

The United States was not the only place where homespun acquired political meaning. When Mohandas Gandhi returned to India from South Africa in 1914, he wore an approximation of peasant clothing. Soon he was preaching the gospel of *swadeshi*, or self-sufficiency, urging Indians to burn imported fabrics and adopt simple clothing made from *khadi*, or homespun. Ironically, there were so few peasants who still spun by hand that he had to search out those who could revive the dying craft, and because *khadi* was so much more expensive than industrially produced fabrics, it was difficult to persuade people to use it. Gandhi’s promotion of *khadi* had two objectives—to assert India’s economic independence and to unify the nation by establishing a national dress common to all classes. Gandhi wore a simple loincloth to demonstrate his solidarity with poor peasants who could not afford more elaborate clothing. Although few of his followers went to that extreme, the *khadi* cap he designed did become an emblem of national unity.

See also **Europe and America: History of Dress (400–1900 C.E.); Fashion and Identity; Handwoven Textiles; Politics and Fashion; Spinning.**

#### BIBLIOGRAPHY

- Baumgarten, Linda. *What Clothes Reveal: The Language of Clothing in Colonial and Federal America*. New Haven, Conn., and London: Yale University Press, 2002.
- Faust, Drew Gilpin. *Mothers of Invention: Women of the Slaveholding South in the American Civil War*. Chapel Hill and London: University of North Carolina Press, 1996.
- Inwood, Kris, and Phyllis Wagg. “The Survival of Handloom Weaving in Rural Canada, circa 1870.” *Journal of Economic History* 53 (2) (1993): 346–358.
- Tarlo, Emma. *Clothing Matters: Dress and Identity in India*. London: Hurst and Company, 1996.
- Ulrich, Laurel Thatcher. *The Age of Homespun: Objects and Stories in the Creation of An American Myth*. New York: Alfred A. Knopf, 2001.

*Laurel Thatcher Ulrich*

**HOOP SKIRT.** See **Crinoline.**

**HORST, HORST P.** Horst Paul Albert Bohrmann (1906–1999) was one of the most creative and prolific fashion photographers of the twentieth century. (He took the name of Horst P. Horst during World War II and was known professionally simply as Horst.) From the be-

ginning of his career in 1931 until 1992, when failing eyesight forced him to abandon his work, his photographs graced the pages of American, French, British, German, Spanish, and Italian editions of *Vogue*, *Vanity Fair*, *House and Garden*, and a host of photography magazines, books, and catalogs. Horst came to prominence in the 1930s, by which time the power unique to the medium of photography was dramatically apparent to promoters of fashion. He is appreciated in the twenty-first century not only for the spare elegance and refined glamour of his fashion work, which produced icons of the genre, but also for his myriad portraits, male and female nudes, flower studies, and pictures of homes and gardens.

#### Early Life and Training

Horst Bohrmann was born in Weissenfels-an-der-Saale, Thuringia, in 1906, the second son of prosperous, middle-class, Protestant parents. The family suffered financial hardships as a result of World War I but eventually recovered in the 1920s, enabling Horst to attend the Hamburg School of Applied Art, where he studied furniture making and carpentry. Exposure to Bauhaus principles and personalities led him to seek an apprenticeship in Paris with Le Corbusier. However, Horst was disappointed both with the projects and the great architect himself and soon quit. Wandering about Paris in search of something more vital, he encountered the fashion photographer George Hoyningen-Huene, by then well-established at Condé Nast. Soon Horst was a familiar figure at the studio, helping his older friend arrange sets and lighting, as well as serving as a male model for some of Huene’s most striking swimwear images, and even starring in a short film with Natasha Paley (now sadly lost).

#### First Photographic Assignments

In the spring of 1931 Horst was given a sudden chance to try his own hand at the métier. Dr. Mehemed Agha, American *Vogue*’s celebrated art director, was then visiting Paris and thought Horst might have the required talents. Horst passed his initial tests, which required still lifes of accessories and jewelry, with flying colors, these first photographs being published in the November and December issues of *Vogue*. An invitation to work from American *Vogue* soon followed, but the engagement was short-lived: he was sent back to Europe for insubordination. When Hoyningen-Huene later left Paris for an assignment for *Vanity Fair* in Hollywood, Horst shouldered his work, and when his friend and mentor left *Vogue* for good in 1935, it was Horst who inherited the mantle as photographer-in-chief. Almost immediately, Condé Nast recalled him to New York, though he was allowed to continue to photograph the Paris collections each season. By 1937 he was firmly established in New York.

In 1942 Horst volunteered to serve in the United States Army, and despite being initially classed as an enemy alien, he was called up in July 1943 as a photographer. His assignments, however, remained on American

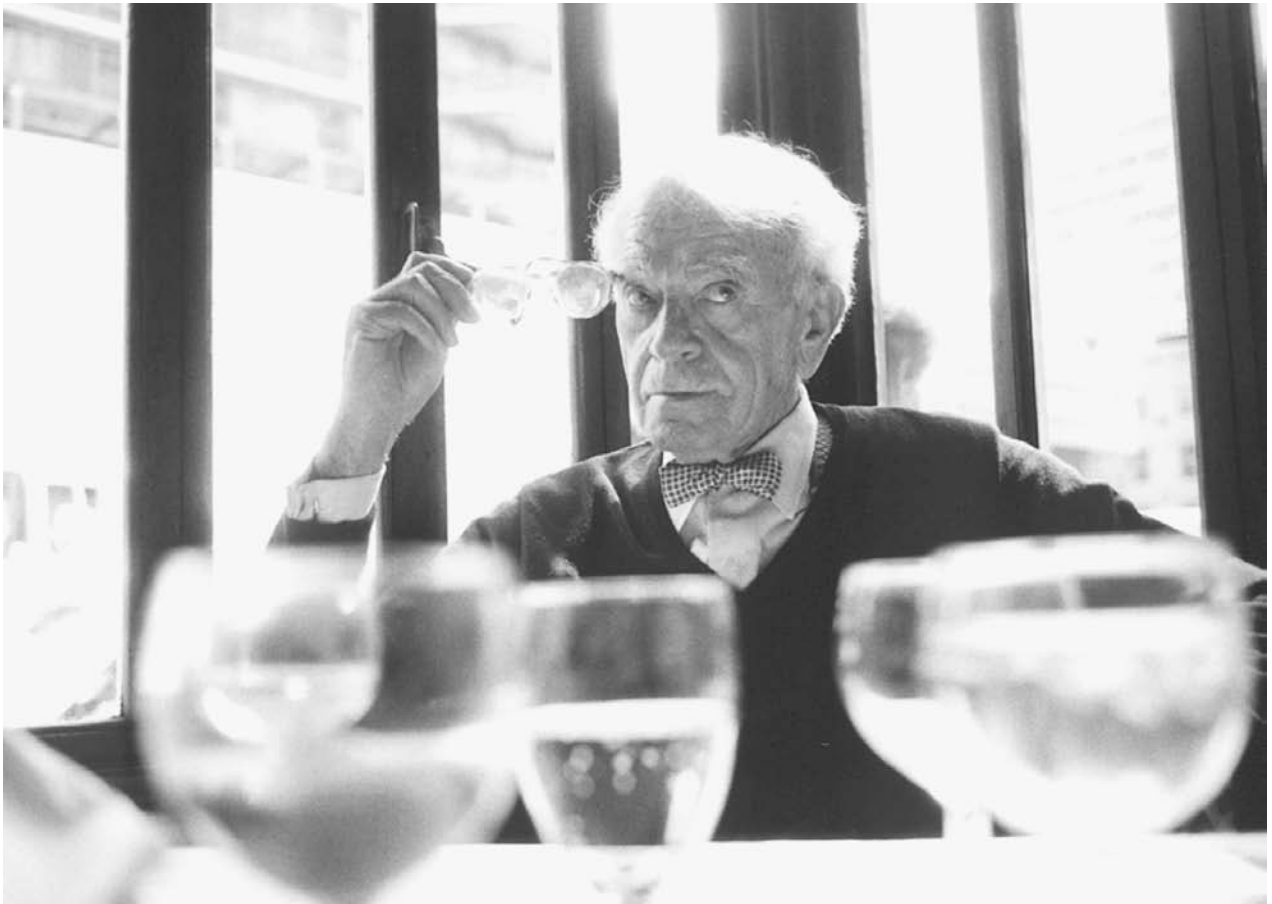

**Horst P. Horst.** One of the most prolific and inventive fashion photographers of the twentieth century, Horst P. Horst first came to prominence in the 1930s. During a sixty-year career in photography, his photographs appeared in numerous magazines, including *Vanity Fair* and *Vogue*. COURTESY OF FAHEY/KLEIN GALLERY, LOS ANGELES, @ WWW.FAHEYKLEINGALLERY.COM. REPRODUCED BY PERMISSION.

soil. At war's end he was invited to the White House for a portrait commission of President Truman.

### Postwar Life and Work

The postwar decades were filled with fashion and portrait assignments on both sides of the Atlantic, as well as trips to Mexico, Syria, Iran, and the new state of Israel. Moreover, he moved in the same circles as luminaries such as the film director Luchino Visconti, the artist Leonor Fini, Coco Chanel, Salvador Dali, Marlene Dietrich, Gertrude Stein, President and Mrs. Eisenhower, Gore Vidal, Yves St. Laurent, and Jacqueline Bouvier. He became close friends with a number of these people.

In 1952 Horst began to fall out of favor at *Vogue*, whose new editor, Jessica Davies, imposed rigid rules on the photographers. His fortunes were restored in 1962, however, when the much more supportive Diana Vreeland arrived to head the magazine. In 1971, on the latter's departure from *Vogue*, Horst gravitated to *House and Garden*, where he had occasionally worked beginning in

1947. He returned to Europe for an extensive cruise-wear assignment with French *Vogue*, which led to renewed work for the magazine.

### Notable Exhibitions and Publications

From the early 1930s Horst exhibited both his professional and personal work, at first in European galleries, then more gradually in museums, most of which were hesitant to accept fashion photography as a legitimate domain of art. Significant group exhibitions include *Fashion 1900–1939* at the Victoria and Albert Museum, London, 1975; *Fashion Photography* and *Fleeting Gestures*, at the International Center of Photography, New York, in 1977 and 1984, respectively; *Lichtbildnisse: Das Porträt in der Fotografie*, at the Rheinisches Landesmuseum in Bonn in 1982; and *Das Akfoto*, at the Fotomuseum in Munich in 1985. Major gallery exhibitions were held at the Galerie la Plume d'Or, Paris, in 1932; at the Germain Seligman Gallery, New York, in 1938; at the Sonnabend Gallery, New York, in 1974 and 1980; at Hamilton's



Gallery, London, in 1986 and 1999; at the Staley-Wise Gallery, New York, in 1984; and at the Galerie Thierry, Paris, in 1999.

Horst's major retrospective of his fashion work was organized by the International Center of Photography, New York, in 1984; it then traveled to the Fortuny Palace, Venice, in 1985. A retrospective look at his fashion photography was held at the Musée des Arts de la Mode, the Louvre, Paris, in 1991. A major retrospective of his portraits was shown at the National Gallery, London, in 2001.

Horst's own books include *Photographs of a Decade*, 1944; *Patterns from Nature*, 1946; *Salute to the Thirties*, 1971; *Return Engagement: Faces to Remember—Then and Now* (with writer James Watters), 1984; and *Horst: Images of Elegance*, 1993.

### Horst's Legacy

Most critics consider Horst's prewar fashion photographs, together with a select number of portraits from the same era, to be his finest work. His style, consistent across the various genres he explored, was characterized by a high degree of eclecticism. There are manifold references to art history, and he made liberal use of classical, baroque, and surrealist props and decor along with witty trompe l'oeil effects. Appreciative of historical precedents, he was as able to fabricate pictorial images in the style of Baron de Meyer as easily as he could cool modernist pictures in the style of Edward Steichen and Hoyningen-Huene. Horst's women subjects, in fashion studies or in portraits, project the power of their sex rather than the power of sex; they are bold, poised, and serene. Horst saw the body in architectonic terms, so that appendages of the body could be severed and reassembled to striking effect. Above all, he is known for his exquisite compositional sense, prompting an early admirer, Janet Flanner, to characterize his work as "a linear romance." His work influenced many younger photographers of fashion, portraiture, flowers, and the nude, including Robert Mapplethorpe, Bruce Weber, and Herb Ritts.

See also **Fashion Photography; Hoyningen-Huene, George; Vogue; Vreeland, Diana.**

### BIBLIOGRAPHY

- Deal, Joe. "Horst on Fashion Photography." *Image* 18 (September 1975): 1–11.
- Ewing, William A. *The Photographic Art of Hoyningen-Huene*. New York: Rizzoli International, 1986.
- Flood, Richard. "Horst." *Artforum* (October 1980): 81.
- Hall-Duncan, Nancy. *The History of Fashion Photography*. New York: Alpine Book Company, 1979. This publication gives an overall context for Horst's contribution to fashion photography.
- Horst, Horst P. *Photographs of a Decade*. New York: J. J. Augustin, 1944.
- . *Patterns from Nature*. New York: J. J. Augustin, 1946.

———. *Salute to the Thirties*. New York: Viking Press, 1971.

Lawford, Valentine. *Horst: His Work and His World*. New York: Alfred A. Knopf, 1984.

Liberman, Alexander. *The Art and Technique of Color Photography*. New York: Simon and Schuster, 1951.

Pepper, Terence. *Horst Portraits: 60 Years of Style*. New York: Harry N. Abrams, 2001. An exhibition catalog. This publication, accompanying the retrospective exhibition of Horst's photographs, *Horst Portraits: Sixty Years of Style*, includes a detailed chronology of Horst's life by Robin Muir.

Rose, Barbara. "Horst in Fashion." *Vogue*, May 1976, 175–176, 208.

William Ewing

**HOSIERY, MEN'S** The term "hosiery" in contemporary usage is generally defined as stockings or socks, more specifically as tight-fitting knit goods that cover men's feet and varying portions of the lower leg, or as knitted feet and leg coverings for women (such as pantyhose or tights). The related term "hose," while used synonymously, is even more specifically historically defined as a man's garment that fully covers the legs, like tights, and is tied to the doublet (a short, close-fitting jacket). The origin of the word "hose" is the Old English "hosa" or leg covering, or Middle English "hose" for stocking. A related German term, "hosen," is also often seen in historical use. In the history of Western dress, the term "hose" has been used to refer to a wide range of men's leg coverings, with or without a footed portion, from early centuries C.E. through the early nineteenth century. These include the Roman lower leg wrappings called *feminalia*, the early northern European footed or ankle-length woven trousers, and medieval criss-crossed leg wrappings sometimes referred to as *chausses*.

### Early Development

Men's hosiery is a garment in which technology and fashion are interlinked in terms of both meeting demand for and inspiring changes in styles. From the Middle Ages through the early Renaissance, there are numerous images in art that portray the bagginess, sagging, and wrinkling of ill-fitting hose worn under tunics or *houppelandes*. As clothing construction technology such as tailoring improved to allow a closer fit over the body, men's legs and leg coverings became more prominent, and hose were the predominant lower body garment for men throughout the fifteenth and sixteenth centuries. For instance, fourteenth- and fifteenth-century Italian tailoring techniques created full-length parti-colored hose for men from woven fabrics cut in panels on the bias. They were sewn with curved seams to tightly fit the leg and lower torso. These techniques also allowed hose to get longer, and by the last quarter of the fourteenth century the two separate legs of hose reached the waist and were joined into one garment, similar to what we today call tights. They were seamed up the back and closed over

the crotch with an overlapping panel or a codpiece. Various trends in color and patterning were seen in men's hose throughout each period of their predominance. Many fashionable hose in the seventeenth century were embroidered with gold and silver thread for a type of embellishment around the ankles called clocks or clocking. Early hose were sometimes constructed with leather soles on the foot that could be worn instead of shoes, and the fourteenth-century fashion for soled hose with long pointed toes is the best example of this.

### Knitted Hosiery

Knitted socks were recovered from Egyptian burial excavations dating to the fourth or fifth century C.E., the same period that knitting was introduced to Europe. Hand knitting of socks was an important industry in medieval Europe and by the sixteenth century had advanced to a fine craft. Silk hose for those who could afford them were hand knitted in the round on needles as fine as wire with very fine silk threads. Well-fitted hose were an important fashion item for men of the gentry and nobility during the sixteenth and seventeenth centuries. Hose worn by lower status men were coarser, knitted by hand in the round from wool or linen fibers, or still made from bias-cut woven fabrics. The production of hose to meet the demands of men's fashion sparked important innovations in knitting. The first knitting machine (called a flatbed frame) was invented in late-sixteenth-century England to make hose. It produced coarse, flat pieces of knitted cloth with eight stitches per inch. Although it could be knit ten times faster than by hand, the cloth was considered suitable only for peasant hose. By century's end this technology was refined to make silk stockings using approximately twenty stitches per inch, creating a very active industry and market for higher quality, high-priced hose that lasted until the end of the eighteenth century. Innovations to the knitting machine in the eighteenth century included refinements in shaping hosiery on the frame during the knitting process. Cotton, from India, was introduced for knitted hosiery in England in 1730. By the beginning of the nineteenth century, fashion changes in men's dress resulted in legs covered by long pantaloons or trousers instead of hose, and knitted hosiery industries declined.

### Later Development

Until the late sixteenth century, both woven and knitted hose were held up by being tied to the waist of a man's doublet with laces called points. By 1540, the full-length style of men's hose was broken up into two or three different sections up the leg called stocks. Each section was sewn or tied to the one above it in order to hold it up on the leg. The lower hose, from toe to knee, were predominantly held up by garters, and, after the 1540s, were almost exclusively knitted. Through the seventeenth and eighteenth centuries, knee-length hose or stockings were worn with breeches. Garters were the most popular method for holding up one's hose until new develop-

ments created highly elastic manufactured fibers in the mid-twentieth century. From the 1770s until into the 1820s, many men padded their hose with "artificial calves" strapped to their legs, if needed, to create the shapely leg demanded by fashion ideals.

By the early twentieth century, men's hosiery was a fully diversified industry, producing a wide range of knitted garments completely shaped and finished on the frame. In the apparel industry, the term "half-hose" refers to socks or stockings that end at mid-calf or lower, and the term "hose" refers to those that end above the knee.

*See also* **Breeches; Doublet.**

### BIBLIOGRAPHY

- Brackenbury, Terry. *Knitted Clothing Technology*. Oxford: Blackwell Scientific Publications, 1992.
- Chenoune, Farid. *A History of Men's Fashion*. Translated by Deke Dussinberre. Paris: Flammarion, 1993.
- Payne, Blanche, Geitel Winakor, and Jane Farrell-Beck. *The History of Costume: From Ancient Mesopotamia through the Twentieth Century*. 2nd ed. New York: HarperCollins Publishers Inc., 1992.
- Tortora, Phyllis G., and Keith Eubank. *Survey of Historic Costume: A History of Western Dress*. 3rd ed. New York: Fairchild Publications, 1998.

*Susan J. Torntore*

**HOSIERY, WOMEN'S.** *See* **Stockings, Women's.**

**HOSPITAL GOWNS.** *See* **Nonwoven Textiles.**

**HOYNINGEN-HUENE, GEORGE** George Hoyningen-Huene (1900–1968) is remembered as one of the finest fashion photographers of the 1920s and 1930s. He was born in St. Petersburg, Russia, to a Baltic nobleman, the chief equerry to Tsar Alexander III, and an American mother whose own father had been the United States Minister Plenipotentiary and Envoy Extraordinary to the Russian court. Huene's early upbringing was one of privilege, though the revolution brought those advantages to an abrupt end: the family's properties were confiscated, and they were forced to flee for their lives.

Huene settled in Paris. Dreaming at first of reclaiming his rightful heritage, he participated briefly in the British Expeditionary Force's disastrous campaign against the Reds in 1918. However, the fiasco taught him that there was no turning back the historical clock and that he would have to forge a new life for himself in the West.

While the family chose exile in London, Huene settled in Paris, where he supported himself with a series of odd jobs, the most interesting being the role of an extra

in cinema. Delighted to be in a city that so valued art, for which he had long harbored a passion, Huene decided to pursue drawing and painting, signing up for classes with the famed cubist instructor André Lohste. Huene was instinctively attracted to the world of couture, which he saw as another manifestation of art, and he was quick to grasp that a topflight fashion illustrator like Georges Lepape or Edouard Benito could command a high salary. Huene first put his drawing talents to work for Yteb, his sister Betty's dressmaking business, and by 1925 he had expanded his clientele considerably, selling illustrations to *Harper's Bazaar*, *Women's Wear*, and *Le Jardin des modes*.

Never one to be chained to a desk, Huene teamed up with his new friend, the photographer Man Ray, to produce a portfolio of "the most beautiful women in Paris." Huene's role had only been to recruit the women, but *Vogue's* Main Bocher (later the couturier Mainbocher) was impressed with the ambitious project, and while he didn't accept it for *Vogue*, he took it upon himself to introduce the young man to Edna Chase, the editor-in-chief of the magazine. This led to his "first real job," as he put it, as an illustrator, though Huene always suspected that Chase's decision had more to do with Huene's access to the world of glamorous women than it did with his drawing skills.

Huene fell into photography literally by chance, though in retrospect he seems to have been slowly gravitating toward the métier. He took every opportunity at the *Vogue* studio to help photographers with their sets and lighting, and when one of the photographers did not appear one morning in 1926, Huene stepped in. Thus began a ten-year photographic collaboration with *Vogue*.

Huene brought a neoclassical style, lightly inflected by cubism, to the magazine, a mix perfectly attuned to the zeitgeist. H. K. Frenzel's introduction to a slim volume of Huene's portraits, published in 1932, notes how

Ionic columns rose alongside factory smoke-stacks, Greek temples alongside railroad tunnels and depots . . . and the ladies and gentlemen of Paris, London, New York and Biarritz enjoyed the sunshine among pedestals from which the gods of ancient Greece looked down in naked silence, between snorting stallions and muscular heroes.

Greek columns, temples, and statuary were common motifs in Huene's imagery; thus ennobling the clothes. Not surprisingly, he admired the couture of Madame Grès ("fluid, harmonious and sculptural"), Madame Vionnet ("Her clothes were built like great architecture"), and Coco Chanel, whom he appreciated for her "absolute assurance of her own talent, competence and authority."

At *Vogue* Huene had the chance to study the contributions of his predecessors, and in the case of Edward Steichen—then chief photographer at *Vogue*—even to watch him work. From Baron de Meyer's early twentieth-century fashion photography he learned the power of suggestion, "the mysterious air of making every woman look

like a vision in a dream," and from Steichen he learned the importance of psychology:

In addition to directing the activities of his assistants the photographer plays the clown, the enthusiast, the flatterer. He acts and talks about other things while his mind is watching the building up of the picture—its lights, shadows and lines; its essential fashion photograph requirements—distinction, elegance, and chic.

Huene also absorbed a great deal from painters, and two friends made particularly strong impressions: the painter and fellow Russian Pavel Tchelitchev, who accepted commissions for magazine covers in addition to his own personal art work and could be as enthusiastic about workman's clothes and army surplus gear as he was about haute couture; and Christian Bérard, an artist famed for his Dionysian temperament that was poles apart from Huene's own more Apollonian sensibilities.

Huene also followed developments in cinema and photography. He rubbed shoulders with personalities as diverse as the French photographer Henri Cartier-Bresson, the American dancer Josephine Baker, and the Armenian mystic G. I. Gurdjieff. He played bit roles in movies and even tried his hand at making three films, all of which were subsequently lost. Although his fashion work has long been given its due, his exquisite portraiture has not received the attention it deserves. His photographs of his great friend and fellow photographer Horst P. Horst, the authors Jean Cocteau and Janet Flanner, the composer Igor Stravinsky, the photographers Baron de Meyer and Cecil Beaton, the actor Johnny Weismuller, the painter and sculptor Alexander Calder, Coco Chanel, and dozens of other celebrities of the day, never resort to formulaic poses or superficial flattery but always find a way of signifying their subjects' originality.

The second significant period of Huene's fashion photography (though it could never match his Paris output) was spent at *Harper's Bazaar* in New York, where he arrived in 1935. Although Huene continued to innovate, the magazine's art director, Alexey Brodovitch's, penchant for bleeding photographs off the page and overlaying graphic elements on the image undermined the integrity of Huene's exquisitely balanced compositions. Gradually he began to lose interest in his photographic work. American fashions could never match their French counterparts; the problem solving that had once given him so much pleasure no longer did so, and the business-is-everything climate of New York was increasingly discouraging.

Huene escaped, temporarily, to the ancient world of the Middle East, looking for spiritual renewal. He found solace on grand voyages across Africa and Arabia. One beautifully written book, *African Mirage, the Record of a Journey* (1938), came of his travels, and other journeys resulted in equally fine photographic albums (*Hellas* in 1943; *Egypt* in 1943; *Mexican Heritage* in 1943; and *Baalbek/Palmyra* in 1946).



In the mid-1940s Huene abandoned fashion photography, leaving it to a new generation less committed to his prewar ideal of elegance. He famously greeted the young Richard Avedon, just beginning his own career in photography, with the words, "Too bad, Too late!" His mind was increasingly set on travel—especially spiritual explorations—and he was willing to try new ways of earning a living. He taught photography at the Art Center School in Pasadena, California, experimented briefly with drugs under the guidance of Aldous Huxley, and served as a color coordinator for several filmmakers such as Jean Negulesco, Michael Kidd, Michael Curtiz, and most notably, George Cukor, who became a great friend.

Hoyningen-Huene first exhibited in a Parisian group show in 1928, in the *Premier Salon indépendant de la photographie*, and was invited to show several works at the seminal *Film und Foto* exhibition in Stuttgart in 1929. He did not show his work again until 1963, when he was selected for Cologne's influential *Photokina* exhibition. However, it was only after his death that he was acknowledged by two important collective exhibitions: *Fashion Photography: Six Decades*, shown at the Emily Lowe Gallery at Hofstra University, Hempstead, New York in 1975, and *History of Fashion Photography*, held at the International Museum of Photography in Rochester, New York, in 1979, and with a full retrospective, *Eye for Elegance*, at the International Center of Photography in New York. In the interim, fashion photography had been treated as a minor commercial vein, and books and exhibitions rare, though one exception should be noted: *Glamour Portraits*, held at the Museum of Modern Art in 1965.

George Hoyningen-Huene died of a heart attack at his home in Los Angeles in 1968. His outstanding contribution to fashion photography is unquestioned, and he broadened this field with his erudition and his flair. In the final analysis the full range of his photography must be considered in any appreciation. His legacy is as a coherent system of images, chiefly of fashion and portrait studies, which were characterized by precision, economy of means, harmony, elegance, and psychological acuity.

See also **Fashion Photography; Film and Fashion.**

#### BIBLIOGRAPHY

- Beaton, Cecil. *The Magic Image: The Genius of Photography from 1839 to the Present Day*. Boston: Little Brown, 1975.
- Chase, Edna Wollman, and Ilka Chase. *Always in Vogue*. New York: Doubleday, 1954
- Devlin, Polly. *Vogue Book of Fashion Photography 1919-1979*. New York: Simon and Schuster, 1979.
- Ewing, William. *Eye for Elegance: George Hoyningen-Huene* (exhibition catalog). New York: Congreve Press; International Center of Photography, 1980
- . *The Photographic Art of Hoyningen-Huene*. London and New York: Thames and Hudson, Inc.; Rizzoli International 1986

- Frenzel, H. K.. *Hoyningen-Huene: Meisterbildenisse*. Berlin: Verlag Dietrich Reineer, 1932
- Harrison, Martin. *Appearances: Fashion Photography since 1945*. London: Jonathan Cape, 1991.
- Horst, Horst P. *Salute to the Thirties*, foreword by Janet Flanner. New York: Viking Press, 1971
- Maloney, Tom. "Hoyningen-Huene." *U.S. Camera Annual*, 1950
- Pepper, Terence. *Horst Portraits, London, Paris, New York*. London: National Portrait Gallery, 2001
- Pucciani, Oreste, ed. *Hoyningen-Huene* (exhibition catalog). Los Angeles: Los Angeles University Press, 1970

William Ewing

**HUGO BOSS** At the start of the twenty-first century Hugo Boss AG was among the biggest companies producing menswear in Germany and, in the last decade of the twentieth century, dominated the German menswear designer market through the distribution of various lines and licenses. In 1923 Hugo Boss founded the clothing company in Metzingen, near Stuttgart in the south of Germany. At first the company specialized in the production of work clothes, overalls, raincoats, and uniforms. From 1933 onward it made uniforms for German storm troopers, Wehrmacht, and Hitler Youth. Boss brought forced laborers from Poland and France to his factory to boost output in the following years. When Boss died in 1948, the factory returned to making uniforms for postal and police workers. In 1953 it produced its first men's suits.

By the early 1970s, after several changes in the management and ownership since the founding of the company, Jochen and Uwe Holy, the grandchildren of Boss, took over work-wear manufacturing, and the duo started to manufacture fashion-conscious men's suits and sportswear. In the following years the new owners turned Hugo Boss from a work-wear manufacturer into a stylish clothes company for formal men's wear. Hugo Boss was the first German company to construct a brand identity within the men's wear sector.

After the relaunch of the Boss brand in the early 1970s, the company developed steadily into an international fashion designer house. In the 1980s, Hugo Boss constructed a high degree of brand awareness through the distribution of licenses and brand extension in fragrances, dress shirts, sportswear, knits, and leatherwear. Boss went public in Germany in 1985. Their formal menswear, in particular, became strongly associated with the Yuppie.

Family control ended in 1992, and since 1993 Mazzotto S.p.A. in Valdagno, Italy, has held majority control of Hugo Boss AG. The company operates in more than ninety countries with a product range including bodywear, cosmetics, evening wear, eyewear, fine clothing, formal wear, fragrances, hosiery, leisurewear, shoes, and watches. Since control by Mazzotto began, Hugo Boss

AG has applied a three-brand strategy for the men's wear market under the labels Boss Hugo Boss, Hugo, and Baldessarini. Boss Man, the company's core brand is divided into three subsidiary labels—Black Label (business and leisure wear), Orange Label (urban sportswear), and Green Label (outdoor activewear).

The Hugo brand encompasses an avant-garde collection, which is designed for business and leisure, and which combines unconventional details with new materials. The Baldessarini brand is the most sophisticated label, featuring the finest Italian fabrics and hand stitching. As a traditional men's wear manufacturer, Hugo Boss made an unsuccessful attempt to start a women's wear line in 1987. Eleven years later Hugo Boss successfully launched the female counterpart to the male Hugo label. In 2000 the designer brand introduced Boss Woman, designed for the sophisticated female businesswoman. The Hugo Boss brand is clearly defined by a dynamic design with an emphasis on functionality, clean lines, and attention to details.

The Hugo Boss collections are distributed on the international market through selected specialty stores and Hugo Boss monobrand shops. The collections are designed and managed according to a standardized concept that reflects the clean, stylish brand image applied at monobrand shops worldwide. Nevertheless, the company opened a 20,000-square-foot store in New York City in 2001 that presented all brands and collections under one roof for the first time.

*See also* **Formal Wear, Men's; Suit, Business; Uniforms, Military; Uniforms, Occupational.**

#### BIBLIOGRAPHY

Clark, Andrew. "Dressed for Success." *Guardian*, 24 February 2001. Available from <<http://guardian.co.uk>>. Interview with Werner Baldessarini, the chairman of Hugo Boss.

Givhan, Robin. "Fashion Firm Discovers Its Holocaust History: Clothier Hugo Boss Supplied Nazi Uniforms with Forced Labour." *Washington Post*, 14 August 1997.

*Thomas Hecht*



**IKAT** Ikat is a resist dye technique used to pattern textiles. The more common methods of resist dyeing involve covering parts of a fabric to shield the reserved areas from penetration of the dye, as in tie-dyeing, where threads are wound around the fabric, or in batik, where wax is applied to the surface of the cloth. The term “ikat” by contrast, is used for a process where prior to weaving, warp (lengthwise yarn) or weft (crosswise thread) or sometimes both are tied off with fiber knots that resist absorbing color and are then dyed. To facilitate the pattern tying, the threads are set up on a frame. They are then grouped into bunches of several threads to be tied at once; this results in the creation of knot units from which the overall pattern is built up. Resist ties are removed or new ones added for each color; their combinations create the design. After dyeing is completed, all resists are opened, and the patterned yarns are woven.

The word “ikat” comes from the Malay-Indonesian word for “tie”; it was introduced into European sources of textile technology and history in the early twentieth century when Dutch scholars began paying attention to the rich textile traditions of the Netherlands Indies, the present-day Indonesia. Depending on whether the tied fibers are applied to the warp or weft, the technique is identified as either warp ikat or weft ikat. A third variety, double ikat, combines both warp- and weft-tied resist. For the pattern to be visible, the resist-dyed thread system has to be the prominent one, so for warp ikat, the weave has to be warp-faced, and weft ikat needs a weft-faced structure, which means that either warp or weft is predominantly visible. Plain weave is especially suitable for showing the ikat’s design, but for weft ikat, a twill weave may also be used. Double ikat, where the design is built up from both systems, should ideally be woven in a balanced weave, with warp and weft equally visible. All textile fibers may be used for ikat, although silk and cotton are the most common ones. For the seminal study of ikat as a resist dye technique, its history and geographic distribution, see Alfred Bühler (1972).

### History of the Technique

While it is not known when and where the resist technique first developed, Asia has several cultural regions with a particularly strong ikat tradition. Maritime South-

east Asia, India, and Central Asia are all potential candidates for the origin of the technique, but it may also have evolved independently in several locations. Ikat may have spread at an early age through many parts of the Austronesian-speaking world, as technical similarities exist between Indonesian ikat production and that of Madagascar, which was settled by maritime Southeast Asians early in the first millennium C.E. As Malagasy weavers also use a distinctly Austronesian version of a horizontal back-strap loom, the technique may have arrived simultaneously with the spread of loom technology. Ikat patterning is probably represented in garments shown in the Ajanta cave paintings of India (from the fifth to the seventh century). A fragment patterned in the technique, kept for centuries in the Horyuji temple at Nara but now in the Tokyo National Museum, was apparently brought there from China during the Tang period (618–907 C.E.), but was probably produced in Central Asia. Cotton textiles with relatively simple warp ikat stripes were made in Yemen by the eighth or ninth century and were traded to Egypt, where they have survived.

Early ikat production is also testified for pre-Columbian South America, in particular Peru, where a few examples of ikat survive from before the common era. The Mapucha of Chile still produce indigo-dyed warp ikat textiles. Guatemalan ikat, on the other hand, may have been introduced originally as trade textiles brought by the Spanish from the Philippines and could ultimately have a Southeast Asian source. West African weavers also make use of the technique, in particular in Ghana, the Ivory Coast, and Nigeria. In the Mediterranean world and Europe, ikat apparently developed in response to Islamic textiles; it first appeared in Italy in the seventeenth century as an influence from warp-ikat striped *mashru* cloth (a warp-faced satin weave with silk warp and cotton weft) made in Syria and Turkey. For its spread through Europe, especially France, Majorca, and Spain, see Marie-Louise Nabholz-Kartaschoff.

Nineteenth- and twentieth-century evidence show that at least during the last two hundred years, Asia produced the most varied and highest quality ikat textiles, and a survey of the technique will inevitably have the continent as its main focus, although the occurrence of ikat worldwide needs to be acknowledged. Particularly fine





### GLOSSARY OF TECHNICAL TERMS

**Balance weave:** A textile structure in which the number of yarns in the lengthwise direction and the number of yarns in the crosswise direction are similar in size and number.

**Warp/warp yarn:** Lengthwise yarns in a woven fabric.

**Warp-faced:** Fabric in which the lengthwise (warp) yarns predominate on the surface of the fabric.

**Weft/weft yarn:** Crosswise yarns in a woven fabric. Synonyms: filling, woof.

**Weft-faced:** Fabric in which the crosswise (weft) yarns predominate on the surface of the fabric.

material survives from India, Central Asia, Southeast Asia, and Japan. China, otherwise of course a producer of quality textiles, apparently has not developed the technique to any degree, at least outside its Central Asian provinces.

#### Regional Characteristics in Asia

India and Southeast Asia are the geographical regions with the greatest diversity of ikat weaving, with all three technical versions present and developed to an unrivalled variety of designs. In India, Andhra Pradesh, Orissa, and Gujarat are best known for their ikat traditions, but Tamil Nadu in southern India also once had an active production. The most famous, and complex, of ikat textiles are the *patola* (sing. *patolu*) of Gujarat. These double-ikat, sari-length silk cloths are in the early 2000s only made by a small group of weavers in Patan. Their designs require great precision in planning and setting up of warp and weft, as the desired effect is a clear outline of patterns, rather than the softly blurred appearance characteristic of many ikat traditions. Patola are still worn as saris in India, but they also have ceremonial functions, such as at weddings, where they may be used to drape the bride and bridegroom.

For centuries, patola were not only made for an Indian clientele, but were also luxury trade items. Their international reputation as high-quality export textiles was already established in Southeast Asia when the first Europeans became involved with the maritime trade of Asia in the early sixteenth century. The Portuguese and later Dutch and English traders discovered that patola were essential exchange items for establishing local contacts in the lucrative spice trade. Patola made for the Southeast Asian market were usually smaller in size than the sari-

length textiles found in India, and they had distinctly different designs.

Patola imitations in weft ikat are produced in Rajkot in Saurashtra, western Gujarat; these use conventional patola designs but are garish in colors and technically less ambitious. Andhra Pradesh and Orissa produce both cotton and silk warp and weft ikat, sometimes using both in a single cloth, such as the *telia rumal* handkerchiefs made in Chirala, Andhra Pradesh. Warp and weft may be matched to create simple double ikat patterns, but more often warp and weft ikat are placed separately in different parts of the textile. Tamil Nadu and Karnataka in southern India formerly produced fine cotton and silk sari with very simple ikat bands.

Southeast Asia has a strong warp ikat tradition, usually worked on cotton. Particular highlights are found in Sarawak (Borneo) among the Iban, the Toba Batak of northern Sumatra, and throughout eastern Indonesia, specifically on Sumba, Roti and Savu, Flores, and the Solor Islands. Weft ikat is most commonly associated with silk weaving and is found predominantly in mainland and western maritime Southeast Asia; it occurs in Cambodia among the Khmer, in southern Sumatra, and (as a cotton version) on Bali. Double ikat is only found in Bali in the village of Tenganan, where the ceremonially important cotton *geringsing* cloths are woven. The designs used in Southeast Asian ikat combine indigenous motifs with outside influences, as they incorporate patterns that go back to the region's prehistory, with a response to Indian textiles. Particularly relevant are the patola formerly traded from Gujarat, which had a major impact on local ikat textiles.

Central Asia produces silk warp ikat garments, in particular coats worn by men and women until the early twentieth century. These were made by specialist weavers and dyers in the city-states along the Silk Road, often involving the local Jewish communities, and were worn as heavily quilted outer garments, as well as undercoats without cotton padding. These robes are characteristically dyed with vibrant colors and large-scale designs; unlike some other ikat traditions that may place importance on a precise outline of patterning (the patola of Gujarat and warp ikat textiles from Borneo and eastern Indonesia), the bold effect is the desired aesthetic achievement, rather than a clearly defined motif. In East Asia, ikat continues to be commonly produced in Japan. It was traditionally only dyed with indigo, although other colors have become used as well. One finds both warp and weft ikat, often combined into double ikat patterns.

While ikat production in India, Central, and East Asia is done in commercial or craft industry-oriented workshops and is mainly carried out by men, the tying and weaving of ikat in Southeast Asia is definitely a female activity. The textiles of the region are often associated with ritual and ceremonial functions that concern both individuals and the community. They may be pre-

sented as gifts at marriage and funerals, or may be essential paraphernalia for ritual cycles and ceremonies. Even when they are made to be used by men, their production is inevitably closely linked to the female aspect of society, both in mainland and maritime Southeast Asia.

### Production and Function

Ikat continues to be produced in the early 2000s, especially in Southeast and East Asia. It may also have a revival in India, as traditional crafts there experience a certain renaissance. Ikat textiles are used for both dress and display purposes. They can be appreciated for their decorative beauty alone, but because a complicated pattern is difficult to achieve in this technique, especially when several colors are part of the design, ikat garments may carry a high prestige value as well. This is apparent in the use of patola as costly sari fabrics worn by women in India; it also contributed to the local appreciation of ikat garments in Central Asia, where the robes were considered most prestigious if they included several colors, as this implied the repeated tying of the warp threads and further dyeing, which is both time-consuming and technically demanding.

Although most ikat textiles produced in Southeast Asia are used as garments, such as the wrap-around sarong or an open shoulder cloth, they may in addition acquire a considerable ceremonial importance. They are produced by women and therefore have become closely associated with the status females have in the region, which in general is high and inevitably is linked to concepts of fertility. The ikat textiles are frequently a prescribed part of elaborate gift exchanges accompanying a wedding. Textiles with a ceremonial function often use designs and color combinations that are considered traditional in the local context; comparing current patterns to those found in early museum collections can provide confirmation that designs have been established for several generations and continue to follow certain conventions. Ikat textiles made for daily wear, on the other hand, display local fashions in both design and color and may change relatively quickly.

See also **Dyeing; Dyeing, Resist; Weave, Plain; Weave, Twill.**

### BIBLIOGRAPHY

- Bühler, Alfred. *Ikat Batik Plangi*. 3 vols. Basel, Switzerland: Pharos Verlag, 1972.
- Bühler, Alfred, and Eberhard Fischer. *The Patola of Gujarat: Double Ikat in India*. 2 vols. Basel, Switzerland: Krebs Verlag, 1979.
- Crill, Rosemary. *Indian Ikat Textiles*. London: Victoria and Albert Museum, 1998.
- Fitz Gibbon, Kate, and Andrew Hale. *Ikat: Silks of Central Asia*. The Guido Goldman Collection. London: Laurence King, 1997.
- Gittinger, Mattiebelle. *Splendid Symbols: Textiles and Tradition in Indonesia*. Washington, D.C.: The Textile Museum, 1979.

Maxwell, Robyn. *Textiles of Southeast Asia: Tradition, Trade and Transformation*. New York: Oxford University Press, 1990.

Nabholz-Kartaschoff, Marie-Louise. *Ikatgewebe aus Nord- und Südeuropa*. Basler Beiträge zur Ethnologie Band 6. Basel, Switzerland: Pharos Verlag, 1969.

Tomita, Jun, and Noriko Tomita. *Japanese Ikat Weaving*. London: Routledge and Kegan Paul, 1982.

Zernnickel, Maria. "The Textile Arts of Uzbekistan." In *Uzbekistan: Heirs to the Silk Road*. Edited by Johannes Kalter and Margareta Pavaloi. London: Thames and Hudson, Inc. 1997.

Ruth Barnes

**IMPLANTS** An implant is the introduction of a material or object under the skin that changes the shape of the body in that area. Implants create temporary, semi-permanent, and permanent body modifications that transform the volume, space, and mass of a body area. Implants require an invasive procedure or surgery, often plastic or cosmetic surgery.

Plastic surgery refers to surgical techniques aimed at reconstructing, correcting, or modifying parts of the human body. Cosmetic surgery is a subdivision of plastic surgery, which refers to any surgery that modifies a person's appearance, but is not necessarily for a health-related reason. Cosmetic surgery makes it possible to replace, reconstruct, or reshape every external part of the body, from the cheeks to the buttocks. Examples of cosmetic surgery that utilize implants include facial, chest, buttock, and calf augmentations.

### Facial Augmentation

Changing of the facial structure can involve a wide variety of implant practices, such as soft tissue, cheek, dental, and chin implants. These implants are used for reconstructive and cosmetic purposes. A common facial augmentation is to remove or improve the appearance of existing scars and facial lines. In the latter part of the twentieth century, many rigid and injection implants were developed; the most successful and popular types were soft tissue implants.

### Soft Tissue or Injection Implants

Soft tissue implants include collagen, human fat and tissue, Botox, and Gortex. A common type of collagen implant is made from the deep surface of bovine skin. Bovine collagen implants consist of sterile, purified, reconstituted bovine collagen, which is injected into the dermal layers of the skin. The body absorbs collagen, resulting in a smoother skin surface. This type of implant lasts from four to ten months.

Excess fat removed from the body can be injected into areas with wrinkle lines to reduce their depth. This procedure is called "fat grafting," which utilizes a strip of a deep layer of underlying fatty tissue, which may be taken

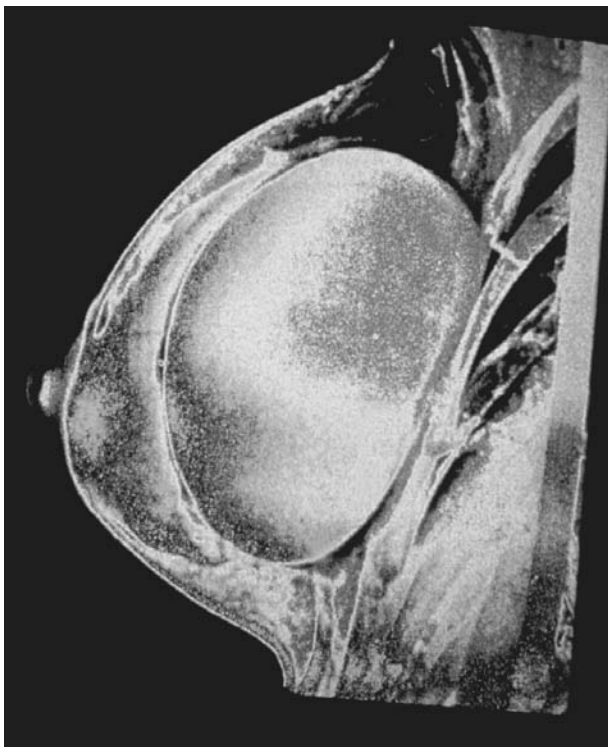

**X-ray of breast implant.** Silicone gel was used in breast implants until 1992, when medical concerns led to its replacement with water-filled silicon bags. © HOWARD SOCHUREK/CORBIS. REPRODUCED BY PERMISSION.

from any location on the body. The fatty tissue is then injected below or threaded into the wrinkle lines, where it may last for several years.

Botox is a safe liquid derived from botulism toxin. This type of implant paralyzes the muscles underneath facial wrinkles, thereby producing a smooth skin surface. Botox is effective for up to five months.

Gortex, a Teflon implant, is injected below wrinkle lines to produce a permanently smooth transformation of the skin's surface. This substance is nontoxic and does not need additional surgery. This type of implant does not need to be repeated, but it can be removed whenever desired or if complications arise.

Cheek and chin implants have been used to reconstruct and reshape the face since the mid-twentieth century. The most common implants for these augmentations include both injection and rigid implants.

Rhinoplasty is a surgical procedure that modifies the size or shape of the nose. Early records, from about 600 B.C.E., refer to Sushruta, an Indian surgeon who implanted necessary cartilage structures and reconstructed noses that were amputated as a result of punishment.

Dental implants are used to replace, reconstruct, or enhance teeth or the jawbone. There is evidence that den-

tal implants were used in early Egypt, where the upper classes replaced their teeth with those extracted from slaves, poor people, or animals. A wide variety of dental implants existed during the twentieth and early twenty-first century, and most involved surgical procedures.

### **Hair Grafts or Implants**

One type of hair replacement is to use small hair grafts or implants, which typically vary in size from two to ten hairs. The grafts are placed in the scalp according to the natural hair patterns. Originally punch grafts were used that placed about ten hairs with each punch. By the late twentieth century, mini- and micro-grafts placed groups of one to four hairs at a time.

### **Chest Augmentation**

While both males and females have chest augmentation, the primary difference is that female augmentations are referred to as breast implants, whereas males have pectoral implants. Breast implants typically replace or enhance and increase the size of a female's breast. Pectoral implants push the chest muscles outward, creating the appearance of a larger, more muscular chest.

Chest augmentation involves inserting implants into the chest. Silicone gel chest implants were invented by the plastic surgeons Thomas Cronin and Frank Gerow in the early 1960s. This silicone gel implant was developed into a commercial product by Dow Corning in 1962. Other manufacturers introduced chest implants in the late 1960s. Chest implants were once filled with silicone gel, but it was banned in 1992 due to health risks. The Federal Drug Administration (FDA) reported that silicone was linked to connective tissue diseases, such as arthritis and lupus. As a result, chest implants were modified to silicone bags filled with saline. Saline implants are shaped and sized according to the desired appearance, and the implant surface can be smooth or textured. Breast implants are either round or teardrop-shaped, while pectoral implants are more flat and circular. The type of implant used will usually depend on individual preferences.

### **Penile Implant**

First used in the 1950s, the penile implant or prosthetic is a treatment for impotence. The penile implant is a set of prosthetic tubes within the penis designed to mimic the creation of an erection. There are three types of penile implants: the semirigid implant, the inflatable implant, and a self-contained inflatable implant.

### **Calf Augmentation**

Calf augmentation enhances the calf muscle of the leg with the placement of a solid silicone rubber implant on the back of one or both calves. Men and women have calf augmentation to create more shapely calves or to produce symmetry, when one calf is significantly smaller than the other.



### Buttock Augmentation

Buttock implants augment a flat posterior. The implant is placed in between the gluteal muscles, increasing and changing the shape of the buttocks. There are two types of implants to be used for this procedure: solid and cohesive implants. The solid buttock implant is made from a dense silicone, which is uncomfortable and lacks a natural appearance. The cohesive implant is made from a lighter, less-dense silicone gel, with additional flexibility. Both types of implants resist rupture, but the FDA has approved only the latter.

### Teflon and Surgical Steel Implants

Teflon and surgical steel implants are primarily subcutaneous body art used by the Modern Primitive subculture. These implants take shape as horns, beads, gauged jewelry, organic shapes, and the like. Steve Haworth is a “3-dimensional body modification artist,” who invented the specialized instruments and procedures to place the Teflon implants just under the surface of the skin. The procedures used for these types of implants are invasive, but do not require any anesthesia (occasionally local anesthesia is used for more extensive implants). In 1999, the *Guinness Book of World Records* recognized Steve Haworth as the “Most Successful 3-Dimensional Artist” in the world.

### Health Risks

As with most body modifications that require surgery, implants have associated health risks. Common risks include pooling of serum or blood, blood clots, infection, prolonged swelling, rupture, and loss of sensation. Cosmetic problems can also occur, such as rippling of the skin or undesired settling.

See also **Body Building and Sculpting; Plastic and Cosmetic Surgery.**

### BIBLIOGRAPHY

- Babbush, Charles, ed. *Dental Implants: The Art and Science*. Philadelphia: W. B. Saunders, 2001.
- Camphausen, Rufus C. *Return to the Tribal: A Celebration of Body Adornment*. Rochester, Vt.: Park Street Press, 1997.
- Engler, Alan. *Body Sculpture: Plastic Surgery for the Body of Men and Women*. 2nd ed. New York: Hudson Publishing, 2000.
- Haiken, Elizabeth. *Venus Envy: A History of Cosmetic Surgery*. Baltimore: Johns Hopkins University Press, 1999.
- Mercury, Maureen. *Pagan Fleshworks: The Alchemy of Body Modification*. Rochester, Vt.: Park Street Press, 2000.

Theresa M. Winge

**INDIA: CLOTHING AND ADORNMENT** Contemporary Indian dress is based upon a rich history of fashion development through 4,000 years (Ghurye 1966). The country contains one-sixth of the world’s population, divided into three language families—Sanskrit, Dravidian, and Proto-Munda—each contributing its own

dress traditions. Dress varies by region, whether it is a difference in how a woman’s sari or man’s dhoti is wrapped; the cut of the design; the use of the headdress or hair dressing; or the use of temporary or permanent body markings. Caste, religious, regional, or ethnic identity of most rural dwellers and some urbanites is revealed in the design of their tattoos, jewelry, or headdress. Clothing style often communicates the same information. This entry focuses on popularly worn garments and major fashion trends of the recent era.

If an individual lives in rural India—particularly as a member of a low-income, minority, or low-caste group—choices will be smaller than those of urban, mainstream, or elite compatriots. Limitations in rural choice result, too, from a higher saliency of caste, ethnicity, and religion, and lower expectations of involvement in the fashion system.

In urban areas, comprising 30 percent of the population, and among elites, choices in dress are much greater. Though the dress traditions of minorities seeking upward mobility are giving way to the dress of dominant regional and national communities, the latter is developing into a fast-moving fashion industry. Regional and national styles of dress provide some anonymity to the wearer regarding social origins. Additionally, world dress provides further alternatives in cities to elite women and men of all classes.

### Wrapped Garments

Wrapped garments constitute the national wardrobe mainstay. Great complexity and varieties of garments and wrapping styles lie behind India’s stereotypic sari. Wrapped garments for the torso—primarily women’s sari and *veshti* and men’s dhoti, *lungi*, and *veshti*—include cloths 2.5 to 12 yards long, with women wearing the longer garments. Additional wrapped garments include shawls; veils for women, for example, *dupatta*, *chunri*, and *orbni*; 4–7.5-yard-long *pagri* turbans and shorter informal head wraps for men; men’s *kamar band* “waist ties”; and other items worn within minority groups, whose populations typically run to millions.

Wrapped garments are surface designed or woven to size on the loom with border designs on all four sides. The distinctive design of a garment, as wrapped on the body, results in the pattern of creases, pleats, and folds that the cloth makes. Women’s sari borders are wide. Their placement on the body defines the main lines of each wrapped style. With a glance at fabric characteristics and border placement, an onlooker can tell from which ethnic region an individual, or at the least, her sari originates.

### Preshaped Garments

Preshaped garments are not as ancient in India as wrapped forms of dress. Yet the *orbni* worn with *ghaghra* skirt and *choli*, a bodice front and sleeves secured across the back by ties, first appeared in pre-Muslim Gujarat in the tenth century (Fabri 1977). Both cut and sewn and



**Indian women in fashion show.** Wrapped garments such as these are the oldest form of clothing in India and are still considered the traditional dress. Fitted garments were not readily available until the 1970s. © REUTERS/CORBIS. REPRODUCED BY PERMISSION.

knitted garments are now broadly incorporated into Indian dress practice.

Women have largely retained wrapped forms of dress despite the move into fitted clothing by many rural and most urban men. Yet women combine their wrapped saris with cut and sewn blouses. Still, among the elder population in parts of the rural East and South and in minority rural communities in central and southern India, bare-chested female dress sporadically occurs. For example, very orthodox Brahmin women still cook meals for auspicious occasions wearing only their sari (Boulanger 1997).

The movement under Muslim rule, from the twelfth to nineteenth centuries, toward cut and sewn clothing was strongest in the North and West. Women wear ensembles of *salwar* (narrow-ankle loose pants), *kameez* (tunics fitted with darts and inset sleeves), and *dupatta*; or *ghaghra*, *choli*, and *orbni*. Men of these regions wear *salwar* and *kurta* tunics. Men, who did not adopt pants, still donned tunics of various styles for upper-body dressing. Well-to-do and formal men's apparel expand this variety in tunics with the knee-length *achkan* and other long tunics, coordinating them with a variety of drawstring waist pants—straight-legged *pajama*, *churidar pajama* and *sal-*

*war*—to create ensembles specifying the wearer's social identity and occasion of wear. In the North and West, turbans are broadly worn with these ensembles. Everywhere shawls are worn in winter.

British and European trade and rule, from the sixteenth to nineteenth centuries, introduced more styles of fitted clothing. Sari-wearing women added petticoat underwear and adopted British styles of fitting for their blouses. Men, no longer working in the agricultural or handicraft economy, adopted shorts or trousers and Western styles of shirts, including varieties of cotton knit under and outer shirts. Sweaters became popular—cardigans for women and pullovers for men.

### Jewelry

Typical locations for jewelry include the ears, neck, upper arms, wrists, and fingers. Women additionally wear jewelry on the hair, nose, forearms, waist, ankles, and toes. Turban-wearing noblemen include jewelry in their headdress.

Gold and silver jewelry are worn by both genders and by individuals of all ages, except for orthodox Hindu widows. Following the aesthetic of India's former colo-

nial rulers, strictly decorative jewelry is now worn almost exclusively by women; *raja* “kings” may wear rich jewels for formal appearances. Expensive jewelry is made from natural, polished, or carved items like pearls, coral, and ivory (now replaced with plastic) as well as local and imported diamonds, rubies, sapphires, and emeralds cut and set in India. Indeed, Indian kings and queens taught the European nobility to wear jewels.

In hotter regions of the country, a toddler may wear only a piece of jewelry, but one providing spiritual protection or marking entrance into community membership. Adults wear protective jewelry, too. Among urban middle and upper classes, jewelry has disappeared almost entirely from male dress, except for that which provides spiritual protection, such as rings with stones prescribed from horoscope readings. Women wear such rings as well, but they continue, like their rural sisters, wearing decorative jewelry. Upper-class women are now likely to wear styles of jewelry from a variety of regions. Their consumption of ethnic jewelry as changeable fashion items, not indicators of ethnic identity, marks them as members of the national upper class and global society.

### Scenting the Body

Essential oils for scenting the body are extracted in northern and western India from fragrant plant and animal sources. A broader proportion of women, particularly in southern India, scent themselves by wearing fragrant flowers like jasmine in their hair. The most common methods of scenting the body are daily bathing with fragrant soaps and application of scented bath powder. Middle-class and rural women use face powder to lighten the complexion, in pursuit of a wheat-colored appearance.

### Treatment of Head and Body Hair

Cultural norms of hair treatment stress uncut hair for women and global style short hair for men. Very orthodox high-caste Hindu men maintain one long uncut lock of hair from the crown. Long, thick, very black hair is a highly valued component of an attractive woman. Approaching puberty, if not before, a girl learns to take special care combing and oiling her hair to grow it into an asset as she approaches the marriage market. Women in southern India and girls throughout the country keep their hair in one or two braids, respectively. Northern Indian women usually tie their hair in a bun, with styles differing through history and across regions. Exceptions to these male and female practices are found in minority groups of central and far-eastern India. Among the Bondo of central India, for example, women cut their hair close to the scalp and wear a headband, while men grow their hair long and tie it up (Elwin 1950). Also, long, uncut and matted locks identify the holy man or woman who has given up worldly cares for a life of meditation. In the last twenty years, women in cities and wealthier classes have begun cutting their hair in neck- and shoulder-length styles.



**Indian musicians.** The most prevalent wrapped garment for Indian men is the *dhoti*. Turbans fashioned of varying lengths of cloth are also frequently worn. © LINDSAY HEBBERD/CORBIS. REPRODUCED BY PERMISSION.

Facial hair is treated in a variety of ways, depending on caste, religion, and region. Most men shave their beards, but Hindu men often maintain a mustache. Upturning mustaches are claimed by high-caste men; in rural areas a low-caste man who turns his mustache up may be severely beaten. Full, uncut beards and mustaches are a religious must for orthodox Sikhs, who usually roll the beard under the chin, securing it with a net. Sikh men and women both leave their hair uncut, the men tying it into a bun at the top of the head and covering it with a cloth and turban. Older Muslim men tend to grow a full beard and, if they have made the pilgrimage to Mecca, dye the beard red with henna.

Many Indian men shave their armpits as part of their regular grooming, but women’s body hair removal varies a lot by region and subculture. Some indigenous beauty saloons advertise thread work hair removal treatments as a bridal service. The goal is to make a woman’s skin as smooth as a child’s.



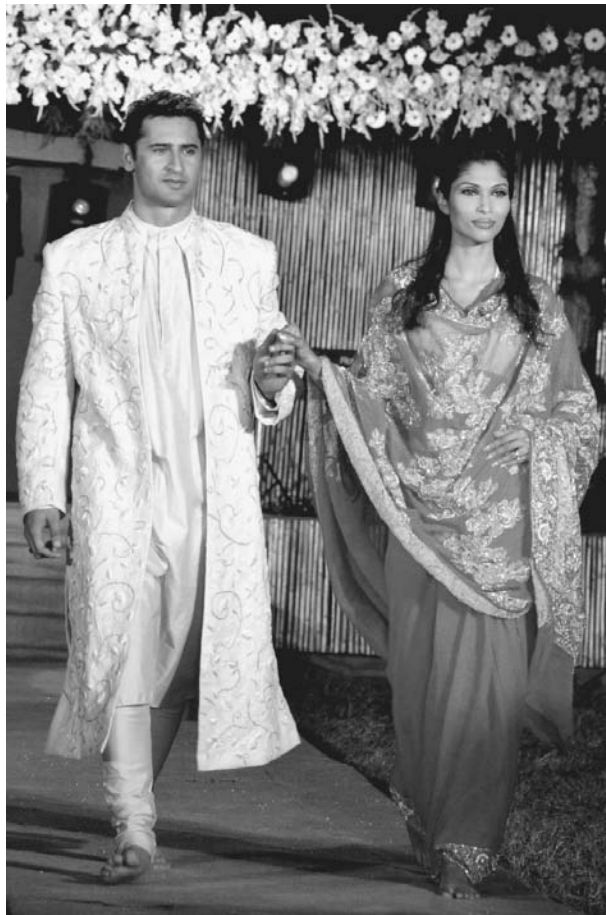

**Contemporary Indian wedding attire.** A male and female model, wearing contemporary Indian wedding fashion, show off the fashions of Indian designers Kalpesh and Purobi Dresswala in 2003. AP/WIDE WORLD PHOTOS. REPRODUCED BY PERMISSION.

### Application of Color to the Body

Adults and children across rural northern India wear *kajal* eyeliner. Users say the eye-black, made from the soot of burned camphor, is cooling and promotes eye health. Black-lined eyes are aesthetically appreciated, too, so *kajal* is not strictly medicinal. Exaggerated *kajal*-lined eyes are essential makeup for male and female classical Indian dancers.

A code of symbols marked on the foreheads of devout men and women in red *sindur* powder or pastes of saffron, rice, or sandalwood mark an individual not only as a Hindu, but also communicates the particular deity to which a person is devoted. Young women concerned with adornment in some fashion periods make the Hindu *bindi* dot on the forehead in a myriad of sari-matching colors and decorative designs. Some designs are available as stick-on *bindis*.

Brides and grooms are massaged with a mixture of oil and turmeric in preparation for marriage. In addition

to the benefits of purification and spiritual blessing, turmeric also makes the skin glow golden. Some southern women regularly apply turmeric facials to enhance beauty. The faces of brides, and some bridegrooms, are decorated with designs in sandalwood paste. Additionally, lyrical designs in reddish *mehendi* are painted on the bride's hands, and on the feet, even if only the minimal design of a red line around the outside edge of the foot. As long as her husband lives, a married woman of eastern India wears red *sindur* in the part of her hair.

### Age and Gender Differentiation

Babies and toddlers wear little or no clothing in rural areas, particularly when temperatures rise, but in urban areas and among the elite they are clothed in the full range of world dress garments for babies. Children under five years of age are dressed in bright, solid colors, especially red. Brighter colors continue for girls thereafter while boys begin dressing down in color. Girls wear dresses with a bodice, dropped waist, and skirt. Boys wear shirt and pants. Adolescent girls wear *salwar-kameez-dupatta* ensembles, though the short-sleeved top, long skirt, and half-sari veil tied over the developing chest continue in popularity in southern India. Adolescent boys wear shorts and later long pants, with a shirt. The clothing of children attending private schools is codified into uniforms.

Gender difference is boldly announced in Indian dress. In extreme western Gujarat, for example, women's blouse design draws attention to breasts, through embroidered circles or panels of bright cloth over the bosom. The tightly wrapped dhotis holding male genitalia in high relief in one region of western India perform a similar function. When outside the home, orthodox Muslim women always wear a two-piece *burqa* over their clothes, covering themselves entirely. Tinkling anklets and bangles, always worn in matched left-right pairs, audibly announce a woman's presence.

Yet even where gender is not so baldly announced, dress clearly distinguishes gender through a variety of means. These include major differences in garment form; the restriction of most of men's dress to somber and neutral colors—especially since contact with colonial dress norms; using rich color, texture, or surface design on every aspect of a women's clothing; and restriction of decorative jewelry to women.

A woman's marital and socially sanctioned reproductive status—unmarried, married, or widowed—is marked in dress. *Sindur* use was described above. Veiling practices vary by area. In some places all females cover their head; in others only married women cover up, and then only in the presence of their husband's senior relatives. Local and caste-specific designs of jewelry mark the status of a woman married to a husband who remains living. In each region, a loose code of garment colors communicates the marital and reproductive status and age of a woman. Absence of adornment in a woman's dress in very orthodox high-caste Hindu families indicates that



**Fashion show by designer J.J. Valaya.** Indian designer J.J. Valaya takes a bow after his runway show in 2003. A number of Indian designers create ensembles that blend traditional elements of Indian dress with modern fashion codas. AP/WIDE WORLD PHOTOS. REPRODUCED BY PERMISSION.

her husband is away or deceased or that she is menstruating (Leslie 1992). Widows wear white, or at least neutral colors.

### History and the Indian Fashion Industry

For 4,000 years India has exported elaborately designed apparel and houseware textiles to the world, especially cottons but also some wools and silks. Importing markets, following their own cultural aesthetic, requested particular patterns and colors, introducing into India new design ideas. Indian textiles also attracted travelers from Europe, middle and central Asia, and China, as well as conquering armies from those same quarters and tourists. Such intrusions also expose Indians to new designs. Under colonialism, British rulers even invented Indian dress traditions, for example, the codification of the Sikh head-dress (Cohn 1989).

At the end of the nineteenth century, the broad array of garments described above and rich textiles—everything from gold-embroidered velvets to transparent cotton

muslins and brocaded silks—were still being made by hand to dress the Indian elite. Middle and lower classes wore a decreasing number of indigenous hand-loomed cottons, favoring cheaper industrially produced cotton garments from British, European, and Indian mills.

During the struggle for liberation from British rule, nationalists abandoned industrially produced cloth and overtly European or luxurious forms of Indian dress. Mahatma Gandhi encouraged production of *khadi*—cloth hand-loomed from hand-spun yarn—and designed a nationalist garment ensemble sewn from *khadi*. This *pajama*, *kurta*, and Gandhian cap outfit communicated a unified identity, replacing the divisive caste and religious identifications of conventional dress. The less ardent continued wearing traditional ensembles, but made from *khadi*. India's luxurious textiles as well as conspicuous displays of jewelry fell out of fashion among urban educated elites and political leaders.

However, diversity in Indian dress continued after the 1947 liberation, in part because 75 percent of the

population still earned their livelihood in relatively unchanged agricultural villages. Government restructuring of the textile and apparel industry also played a major role. To keep employment high in the textile industry, the government developed a bifurcated policy. It facilitated mechanized spinning to feed the hand looms, which clothed the nation and supported revival of waning weaving traditions. Industrial weaving was reserved for export, and suffered severely, but bifurcation gave new life to local styles of hand-loomed saris.

Then in the late 1980s, the generation born after Independence came into power and reassessed its relationship to the global economy as well as sober forms of dress. Reversal of textile policies encouraged industrialization of both weaving and spinning, including production of synthetics. Cotton-polyester blends became popular among the working and middle classes. *Khadi*-producing societies now weave *polyvastra* cotton-poly *khadi*. Foreign-educated designers like Ritu Kumar (1999) began mining the luxurious clothes of Indian heritage for inspiration.

The government established a chain of National Institutes of Fashion Technology (NIFT) in seven of its major cities. NIFT students study local textile technology and design traditions and incorporate them into designs aimed at national and export markets, including the huge Indian diaspora ringing the globe. Richly embellished textiles and apparel are the mainstay of modern fashion design, drawing on India's wealth of skilled hand labor for block-printing, varieties of embroidery, beading, tie-dyeing, and other indigenous textile crafts.

Indian and foreign entrepreneurs and business owners are contributing to the growth of the Indian fashion industry. As late as the 1970s, wrapped forms of dress remained the only available ready-to-wear items. For fitted garments, individuals purchased yardage and had it tailored. Housewives began designing and manufacturing fitted and woven garments, eventually opening boutiques to retail them to urban elites (Castelino 1994). Fashion cycles of design development arose within various sari-weaving traditions (Nag 1989). In New Delhi and Bombay these small beginnings grew into destination shopping areas filled with designer boutiques.

NIFT and the growth in boutiques support a cadre of Indian designers who experiment with India's garment and textile traditions, particularly in surface design in the early 2000s. Even the *ghaghra-choli-orhni* ensemble worn by some women construction laborers has been gentrified into haute couture for a season of the Ethnic Chic trend. The industry has converted *salwar-kameez-dupatta* dressing into the national urban outfit for teenage girls. Women wear their first saris at graduation and marriage (Banerjee and Miller 2003). Ethnic Chic men's wear provides contemporary designs of heritage garments for elite and diaspora bridegrooms.

In the early twenty-first century, the *salwar-kameez-dupatta* ensemble has been globalized. Flared pants with

outside hem slits replace the *salwar*. The *kameez* is cut briefer and shorter. The *dupatta* has been altogether dropped. A stylish woman in an elite society anywhere in the world could wear this ensemble.

The boutique ready-made movement has developed into national chains of stores reaching into all the main cities of India, and into the Indian diaspora via foreign branches and Internet sales sites (Bhachu 2003). In 2004 Anokhi and Fab India occupied the middle rank providing designs for everyday wear in multiple sizes and colors. The Ensemble and Ritu Kumar chains straddled the haute couture and ready-made markets. For the first time, a variety of sized apparel were being retailed to Indian women. Haute couture customers found one-of-a-kind outfits designed, like the ready-made, in garment silhouettes drawn from both Indian heritage and world dress.

Foreign businesses are helping bring world dress to India. By 1995 at least thirty-five agreements between Indian and foreign textile and apparel-producing firms had been made, including Lee and Levi Strauss. These are deals to produce denim in India and sew it into apparel to reach the lucrative Indian jeans market. Several foreign retailers of men's wear have branches in all of India's major cities.

Indian fashion is falling in step with its Western counterpart. The lengths of women's *kameez* and end border of the sari have risen and fallen with Western skirt lengths. Trends in hairstyles started by Elvis Presley, the Beatles, and more recent global media heartthrobs have spread to India, popularized in film by heroes like Raj Kapoor, Rajesh Khanna, and Shah Rukh.

Television programs from the United States and Britain, Bombay films produced as much for the Indian diaspora as for national audiences, and Indians' active maintenance of ties with relatives settled abroad encourage growth in world dress among young women as never before. Young elite women are beginning to catch up with the world dress trend of their male peers. Fashionable young urban women in tight jeans and midriff-baring tank tops are challenging modesty norms requiring that a woman's lower torso be covered by loose clothing.

Changing economic realities and rural television and film viewing are eliciting fashion experiments outside cities, too. Young men are giving up dress that marks low caste, ethnic, or regional identity. Young women, who have been altering the designs of their embroidered trousseau skirts for two generations, are now abandoning them altogether for saris; lower-caste groups are taking up their skirt-embroidering traditions. In western Gujarat state, young women recombine garments from their own and neighbors' traditions to create astonishing *choli-salwar* outfits as revealing as those of their elite urban sisters. The supposedly tradition-bound dressers of rural India are as caught up in fashion changes as their urban compatriots.

See also **Nehru Jacket; Salwar-Kameez; Sari.**



## BIBLIOGRAPHY

- Abreu, Robin. "Weaving a New Survival Strategy." *India Today* 20, no. 23 (15 December 1995): 119.
- Bala Krishnan, R. Usha, and Meera Sushil Kumar. *Dance of the Peacock: Jewellery Traditions of India*. Mumbai, India: India Book House Limited, 1999.
- Banerjee, Mukulika, and Daniel Miller. *The Sari*. Oxford: Berg, 2003.
- Bhachu, Parminder. "Designing Diasporic Markets: Asian Fashion Entrepreneurs in London." In *Re-Orienting Fashion: The Globalization of Asian Dress*. Edited by Sandra Niessen, Ann Marie Leshkovich and Carla Jones, 139–158. Oxford: Berg, 2003.
- Boulanger, Chantal. *Saris: An Illustrated Guide to the Indian Art of Draping*. New York: Shakti Press International, 1997.
- Brij Bhushan, Jamila. *The Costumes and Textiles of India*. Bombay: Taraporevala's Treasure House of Books, 1958.
- Castelino, Meher. *Fashion Kaleidoscope*. Calcutta: Rupa and Company, 1994.
- Chishti, Rta Kapur, ed. *Saris of India: Bihar and West Bengal*. New Delhi: Wiley Eastern Ltd.; National Institute of Fashion Technology and Amr Vastra Kosh, 1995.
- Chishti, Rta Kapur, and Amba Sanyal. *Saris of India: Madhya Pradesh*. Gen ed. by Martand Singh. New Delhi: Wiley Eastern Ltd., and Amr Vastra Kosh, 1995.
- Cohn, Bernard. "Cloth, Clothes, and Colonialism: India in the Nineteenth Century." In *Cloth and Human Experience*. Edited by Annette B. Weiner and Jane Schneider, 305–353. Washington: Smithsonian Institution Press, 1989.
- Dasgupta, Sunil, and Sudeep Chakravarti. "On the Cutting Edge: New Players Are Coming in and Old Ones Are Reshaping Their Strategies." *India Today* 19, no. 9 (15 May 1994): 130.
- Dhamija, Jasleen, ed. *The Woven Silks of India*. Bombay: Marg Publications, 1995.
- Dhamija, Jasleen, and Jyotindra Jain, eds. *Handwoven Fabrics of India*. Ahmedabad, India: Mapin Publishing Pvt. Ltd., 1989.
- Elwin, Verrier. *Bondo Highlander*. Bombay: Oxford University Press, 1950.
- Fabri, Charles. *Indian Dress: A Brief History*. New Delhi: Sangam Books; Orient Longman Limited, 1977.
- Frater, Judy. *Tthreads of Identity: Embroidery and Adornment of the Nomadic Rabaris*. Ahmedabad, India: Mapin Publishing, Pvt. Ltd., 1995.
- Ghurye, G. S. *Indian Costume*. Bombay: Popular Prakashan, 1966.
- Kumar, Ritu. *Costumes and Textiles of Royal India*. Edited by Cathy Muscat. London: Christie's Books, 1999.
- Leslie, Julia. "The Significance of Dress for the Orthodox Hindu Woman." In *Dress and Gender: Making and Meaning*. Edited by Ruth Barnes and Joanne B. Eicher, 198–213. Oxford: Berg, 1992.
- Nag, Dulali. "The Social Construction of Handwoven Tangail Sari in the Market of Calcutta." Ph.D. diss., Michigan State University, 1989.
- Sahay, Sachidanand. *Indian Costume, Coiffure and Ornament*. New Delhi: Munshiram Manoharlal Pub. Pvt. Ltd., 1973.
- Singh, K. S. *The Anthropological Atlas: Ecology and Cultural Traits, Languages and Linguistic Traits, Demographic and Biological Traits*. People of India series, vol. 11. Delhi: Oxford University Press for Anthropological Survey of India, 1993.
- Tarlo, Emma. *Clothing Matters: Dress and Identity in India*. Chicago: University of Chicago Press, 1996.
- Untracht, Oppi. *Traditional Jewelry of India*. New York: Harry N. Abrams, 1997.

Hazel Lutz

**INDIGO** Indigo is a dyestuff known for its blue hue. The color comes from indigotin, a dye derived from the glucoside indican found in some fifty related plants, mostly in the leaves. Of these, *Indigofera tinctoria*, native to India, has the highest concentration of indican that makes deep, dark blues practicable. Less well-endowed varieties grow in Mexico and South America, Europe, Egypt, West Africa, Sumatra, Central Asia, China, and Japan where from ancient times they were used, it is thought, with varying degrees of influence from India.

**Woad and Indigo**

Woad (*Isatis tinctoria*) was used as a blue dye from as early as the fifth century B.C.E. in Europe where a textile fragment from a Celtic grave has been verified as having been dyed with this source of indigotin. The East India companies introduced indigo into Europe in the 1500s; although Europeans recognized its virtues, they outlawed it because it threatened economic disaster to their woad-based economies.

**Indigo Manufacture**

Separating indican, the basis of the dye, from the rest of the plant and changing it into indigotin, the dye, was a laborious undertaking begun by fermenting plant material in vats of water. One hundred pounds of plants yielded about four ounces of the insoluble, granular blue precipitate called "indigo," containing from 10 percent to 80 percent indigotin. The best came from Bengal.

Spices and calico were the focus of the India trade, but traders established hundreds of indigo plantations in the East Indies to supply the growing demand. The Spanish introduced indigo production to Central and South America and the West Indies, where it flourished. In America, the English colonists found indigo to be a lucrative crop, and during the difficult period of the Revolution, for lack of stable currency, lumps of indigo served the purpose.

Supplies of processed indigo dyestuff are nearly nonexistent in the early 2000s because its manufacture is labor intensive and expensive; there is little profit in it now that synthetic indigo prevails.

**Indigo's Distinction**

Unlike madder and most other natural dyes, indigo permanently attaches to fibers, particularly cotton, without

mordant (a chemical that fixes a dye). Silk, wool, linen, and cotton may be successfully dyed with indigo. The dyestuff, however, cannot simply be stirred into the vat because indigo is insoluble. This property confers permanence, but carries the challenge of getting it onto the cloth in the first place.

### Indigo Vats

Undissolved indigo does not adhere to fibers. The purchased chunk must be laboriously ground to a very fine powder and placed in a vat of water containing an agent to reduce, or chemically remove, oxygen molecules from the indican suspended in the liquid. The color of the indigo then changes from blue to a near white known as “indigo white.” In this state the indican may be dissolved, but only if the liquid is alkaline. The art of indigo dyeing lies in maintaining the vat in a state of balance between reduction and solution in such a way that the cloth is successfully dyed without suffering alkali damage.

The earliest method of reducing indigo was to induce fermentation by the introduction of vegetable matter such as seeds into the vat. Later, woad, bran, or madder were used, but the fermentation vat was slow to “come on.” Because it was effective and worked faster than fermentation, orpiment (arsenic trisulphide) came into favor although it was a deadly poison. When ferrous sulphate, or copperas, was found to work better and safely, it became the reducing agent of choice. Toward the end of the nineteenth century, a form of glucose was preferred. For all of these methods, lime was added to the vat to raise the alkalinity sufficiently to allow the white indigo to completely dissolve. The well-known urine vat was best suited to dyeing on a domestic scale; fermenting nutrients in the urine simultaneously generated a reducing and an alkaline solution.

As dyed cloth is removed from the vat, atmospheric oxygen immediately combines with the white indigo to restore the insoluble blue form again, thereby fixing the color mechanically within and upon the surface of the fibers and forming a weak chemical bond. If the dye is not completely reduced, it is not completely dissolved, and in that state cannot adhere to the fibers. An excess of undissolved—hence, unattached—indigo would crock, or rub off. The deepest shades of blue are achieved by successive dips so that the color will be even and rich.

### Patterned Indigo

The Indians are recognized as the originators of resist dyeing with indigo, accomplished by applying wax to protect the cloth wherever it was not to be colored blue, even if that meant most of the cloth. The Japanese and Indonesians employed tie-dye and clamping techniques to resist indigo.

Europeans developed a resist paste made of starch mixed with copper or lead salts that were best applied by block. Discharge pastes that bleached or removed the blue color to make white designs came into use on in-

digo in the 1820s. These were more suitable than resists for cylinder printing. Resist and discharge pastes bearing mordants or lead salts for chrome colors were later developed, permitting the incorporation of colored shapes neatly fitted into the blue ground.

Obtaining a white ground with fine or small blue designs posed a problem. To do so, “pencil blue”—indigo mixed with lime and orpiment—was applied like watercolor with a brush or “pencil.” Variations called China or Fayence blue were repeatedly revised for block and cylinder printing, but never produced a very dark or even color and usually gave trouble.

### Synthetic Indigo

Adolph von Bayer first synthesized indigo in 1880, but it was not until the end of the century that a commercially viable process became available. The synthetic indigo was chemically identical to the natural form, minus the organic impurities. It was very much cheaper and little reason remained to resist; by 1920, natural indigo was little more than a memory in commercial print works.

### Summary

The efficiently aggressive East India traders launched the final three hundred years of intensive commercial exploitation of all aspects of indigo production. By 1900, the venerable role of the “drug” that had shaped cultures and ages was usurped by a distinctly unromantic, synthetic replacement. The ubiquitous blue jeans of the early 2000s testify, undaunted, to the endurance of a global heritage called “indigo blue.” Natural indigo is used only by artisans producing special custom yarns and fabrics. Most distinctively, the Japanese continue to employ age-old tie-dyeing, resist, and stencil techniques to make masterful indigo-patterned fabrics for kimonos.

*See also* **Dyeing; Dyeing, Resist.**

### BIBLIOGRAPHY

- Irwin, John, and P. R. Schwartz. *Studies in Indo-European Textile History*. Ahmedabad, India: Calico Museum of Textiles, 1966.
- Liles, J. N. *The Art and Craft of Natural Dyeing*. Knoxville: University of Tennessee Press, 1990.
- Pettit, Florence. *America's Indigo Blues*. New York: Hastings House, 1974.
- Sandberg, Gosta. *Indigo Textiles: Techniques and History*. Asheville, N.C.: Lark Books, 1989.

*Susan Greene*

**INUIT AND ARCTIC DRESS** People throughout the circumpolar region, including Inuit and Inuvialuit in Canada, Yup'ik and Inupiat in coastal Alaska, Inuhuit in Greenland, Saami in northern Europe, and many groups from Siberia such as the Khanty, Nenets, Evenki, and Siberian Yupik, are recognized as the first people to

make tailored garments. In ancient times, rather than wrapping skins around themselves, pieces were cut and laced together to provide protection from the weather and from spirits, which enabled these northern peoples to thrive. Each region developed its own styles, and people could tell where someone was from by looking at their clothing.

Generally, children wore miniature versions of adult clothing styles. Clothing was beautifully sewn and elaborately decorated with light- and dark-haired skins, skin tassels, beading, hair embroidery, stained or dyed skins, and different types of animal skins. Decorative treatment reflected the individuality of each seamstress, the regional identity or group affinity, and it also helped women appease the spirits, enabling the animal spirits to offer animals to hunters. Hunters saw skin clothing as their most important hunting “tool,” without it they were unable to protect themselves from harm, bad weather, evil spirits, and show the respect needed for animals to wish to give up their lives to the hunter.

Inuit and Inuvialuit from Canada wore hooded pullover skin parkas. In the eastern and central Canadian Arctic women’s parkas had a sculptured hemline creating



**Inuit woman and baby.** In many Arctic regions, a pouch is sewn onto the back of a woman’s parka to hold her child. © RICK RIEWE. REPRODUCED BY PERMISSION.



**Inuit child.** The hooded pullover parka is probably the most basic component of Arctic dress. The hood is generally lined with fur, creating a sunburst effect. © RICK RIEWE. REPRODUCED BY PERMISSION.

front and back tongues or flaps. The length and silhouette of these pieces changed as a young woman entered puberty. A pouch-like area was sewn into the back of parkas worn by women of all ages and used to carry children. Parkas worn by women who were not carrying children had a much smaller pouch than those worn by mothers of young children. A small piece of polar bear or bull caribou skin was placed at the base of the pouch and cleaned when soiled by an infant. Men’s pullover parkas were usually about thigh-length and had either a center front or side splits to allow for extra maneuverability. Men and women wore skin pants; in the eastern Canadian Arctic women wore shorts with leggings.

In the western Canadian Arctic and coastal Alaska women’s parkas were much longer and had a relatively straight hemline. The back panel was cut extra large creating enough space to carry a baby; a sash tied around the waist of the parka prevented the child from falling out. Men’s parkas were shorter, often hip-length. Both men’s and women’s parka hoods were finished with a large “sunburst” ruff made from strips of wolverine and wolf.

Siberian Yupik women wore a pant-top combination suit, which they put on by slipping through the extra-large neck opening. In other areas of northern Siberia





**Inuit woman's parka with embroidery.** Inuit clothing is often elaborately decorated with beads, tassels, dyes, and colored thread. Styles vary from region to region, and often a person's locale can be deduced from details of their clothing. © ROB HOWARD/CORBIS. REPRODUCED BY PERMISSION.

and Europe, women wore unhooded parkas with center-front openings. Infants were bundled up separately and carried in carrying boards. Men wore hoodless parkas with distinctly styled hats.

Inuhuit men and women from northern Greenland wore short, waist-length pullover hooded parkas. Women's parkas had a small narrow tab or flap at the front and back and a pouch for carrying children. They wore skin shorts with long boots. Men wore polar bear skin pants.

In the early 2000s, people from each of these regions wear traditional styles made from contemporary fabrics. Some seamstresses have developed new styles, such as waist-length "packing" parkas made from lightweight fabric for carrying young children around modern homes. As transportation systems shift from dog sled to snowmobile to automobiles, styles used by women carrying children have changed so it is more comfortable to sit in a car seat. Hunters, herders, and other people who travel on the land extensively continue to wear traditional skin clothing as it provides the best long-term cold weather protection. They wear an inner parka with the fur next to their bodies and slip on an outer parka with the fur to the outside in extremely cold weather. Although the styles change regionally, each region's style works together with each of the components to trap warm air. For example, hot air rises up the pant legs, circulates around the torso, and exits at the face opening. When someone gets too warm, the outer parka is removed, along with the waist sash and hood to allow more hot air to escape.

### Materials

In the past and today, caribou and ringed sealskin are the most commonly used materials for skin clothing throughout the circumpolar region. Caribou skin is ideal for cold, dry weather as each hair has a honeycomb core that traps air, which is an excellent insulator. Sealskin is ideal for milder, damp weather as the hair provides very little insulation, however, sealskins are wind and water-resistant. Arctic hare, fox, muskrat, ground squirrel, birds, and other northern animals are used for parkas in areas where caribou is scarce. These skins are more fragile than caribou, but they are extremely warm and lightweight. Wolf, wolverine, and dog skins are preferred for hood ruffs; sometimes parkas that are only worn around the village are trimmed with fox. Fish skins and intestines are used for waterproof clothing in a few areas, especially in southern coastal Alaska. For example, commercial herring fishers from Tooksook Bay in Alaska still prefer intestine parkas to heavy-duty raincoats, as they are lighter and allow body vapor to pass through the skin membrane while preventing rain from entering.

### Technology

Most skins are dried, scraped, wrung and twisted by hand to soften, and then used for skin clothing. Skins are stained red with a variety of mixtures, including shred-



**Man in Arctic dress.** Most clothing in the circumpolar regions is made from animal skins. Depending on the relative dryness of the climate, caribou or seal is the most popular choice. © RICK RIEWE. REPRODUCED BY PERMISSION.

ded and boiled alder bark, powdered ocher (red clay), and, more recently, red dye leached out of wet crepe paper and concentrated red fabric dye. In northern Greenland, skins are de-haired and then painted with acrylic paints, creating a wide range of vibrant colors; plant dyes were used in the past. Special techniques are used for specific skins, for example, fat is sucked from bird skins to protect the quill end of each feather from being damaged by a scraper. Intestines are scraped to remove the inner layer, blown up, and dried before scraping and wringing them until soft. Fish skins are soaked in prepubescent male urine to remove some of the oils, dried, and then scraped until soft.

Skins are sewn together using sinew or connective tissue collected from caribou, muskrat, birds, and other animals. Sinew is cleaned, dried, rumbled by hand until soft, and then split into threads, which are either twisted or braided before being used. Today a synthetic waxed thread is often used as a substitute for sinew on most skins. Needles were made from bone or stone; today fine steel needles are commonly used with a metal thimble. A

few still use the skin thimbles, which were passed down from one generation to the next. A few seamstresses use sewing machines to sew their skin clothing today.

See also **Inuit and Arctic Footwear; Parka.**

**BIBLIOGRAPHY**

Oakes, Jill and Rick Riewe. *Spirit of Siberia: Traditional Native Life, Clothing, and Footwear*. Washington, D.C.: Smithsonian Institution Press, 1998.

———. *Our Boots: An Inuit Women's Art*. New York: Thames and Hudson, Inc., 2000.

Oakes, Jill, et al. *Pushing the Margins: Native and Northern Studies*. Manitoba, Canada: University of Manitoba, 2001.

*Jill Oakes*

**INUIT AND ARCTIC FOOTWEAR** Throughout the circumpolar region, from coastal Alaska, northern Canada, Greenland, and northern Europe to northern Siberia, people protected their feet with layers of inner and outer stockings, inner and outer boots, and inner and outer slippers. Customarily, these layers were made from skins, often with grass or skin insoles. Traditional northern people can identify where you are from and what you do by looking at your skin boots. The styles and materials used to make footwear changed seasonally, regionally, and from one usage to another. Many northern people see footwear as an extremely important part of their clothing because it is the one item that helps humans make the transition from earth to air, from the spirit world to the present world. For example, northerners who move into urban centers or move south often bring a pair of skin boots and carefully store them in the freezer compartment



**Yupik boots from Siberia.** In order to make their *kamik*s (boots) waterproof, Inuits scraped the hair from the animal hide before the tanning process. © RICK RIEWE. REPRODUCED BY PERMISSION.

of the refrigerator, even though these items might be impractical when used in centrally heated buildings and on paved sidewalks. People continue to use traditional footwear for ceremonial and other special occasions.

**Cross-Cultural and Historical Overview**

Arctic footwear generally includes a sole, vamp, and leg section. Soles are either flat or pleated. Pleated soles vary from fine, diffused pleating to one or two large, rounded pleats per centimeter. Vamp silhouettes range in breadth and length, as well as curvature. Leg sections can be a narrow strip only a few centimeters high up to a long, thigh-high panel. In addition, straps are used on some boots and range from narrow skin laces to broad bands; as well, decorative features range from skin embroidery, hair embroidery, beading, tassels, and much more. Each of these characteristics is distinct to individual seamstresses and specific regions. Men's and women's boots are often decorated differently; children's styles are miniature versions of adult styles.

Inuit from northern Quebec, and the eastern and central Canadian Arctic generally prefer flexible boot soles that extend well up over the heel and toe with fine, diffused pleating. Narrow strips of skins are sewn to the bottom of soles for extra traction on some boots. Leg sections are decorated with floral and geometric inlaid skin work. In general, men's boots are decorated with a center front vertical design; women's are decorated with a horizontal design that encircles the boot, possibly representing fertility. Men's and women's boots are usually shin- or knee-high.

In Greenland flexible boot soles wrap only slightly around the heel and toe with fine, diffused pleating. Leg sections are painted black or red, or bleached white. In western and eastern Greenland, men and widows generally use black leg sections; red leg sections are used for married women, and white leg sections with lace and floral embroidery around the top are used for unmarried women. In northern Greenland, women's leg sections are often thigh-high and stiffened. The upper edge is decorated with a narrow strip of polar bear skin. Men's boots are generally shin- or calf-high. In some areas of Greenland, both men's and women's boots are decorated with elaborate skin embroidery designs, which are traced back to specific families and communities. Undecorated boots are also used for kayakers and hunters. Indigenous Greenlanders wear their traditional footwear at special ceremonies such as confirmations, weddings, first day of school, and official community events.

In the western Canadian Arctic and coastal Alaska, stiff, boatlike boot soles are pleated with fine pleats in the northern communities and coarser pleats in the South. Some seamstresses manufacture many pairs of the finely pleated boatlike soles and sell them to seamstresses from other areas who use them for their own footwear. Leg sections are generally shin- or knee-high. Thigh-high boots are worn by trappers in areas where they might en-



counter deep water caught on top of the ice and covered by snow. Dance boots are decorated with red yarn, fur and yarn tassels, beaded panels, pom-poms, and strips of different-colored skins or bias tape.

The variety of styles used in each Alaskan community is exceptional. For example, over fifteen distinct styles are used in coastal Alaskan communities, while just a few miles away across the Bering Strait in coastal Siberian communities only a few styles are used. In Siberia, seamstresses were required to produce at least 100 pairs of skin boots per year for their collective reindeer farms; in Alaska, seamstresses produced footwear for their family and friends, their handiwork was recognized and appreciated by other community members, and occasionally purchased by tourists or cultural institutes. In Siberia, boots are made shin-, knee- or thigh-high from the skins of reindeer legs. Several panels are sewn together to encircle the herder's leg and then attached to a flat, unpleated sole, with a narrow strip of skin sewn in the sole seam. Boots worn by shamans have skeletal lines painted on them using ocher (red clay) mixed with fish eggs or blood. This helps the shamans communicate with the underworld, to show respect, and to appease the spirits thereby protecting people from danger and hunger.

In northern Europe, Saami footwear is unpleated with a firmly stuffed curved toe. The curvature, width, length, and overall shape of the toe vary regionally. Saami slip the toe extension under their ski strap, preventing the ski strap from slipping off their footwear. Leg sections usually extend up to just above the ankle and then a handwoven sash is wrapped around the ankle and up the leg. The sash is decorated with gender-specific designs passed along from one generation to the next. Footwear is decorated with narrow strips of red, yellow, blue, and green fabric sewn into the seams.

### Materials

Caribou, or reindeer (domesticated caribou), and ringed sealskins are the most common materials used for northern footwear. Caribou or reindeer skins are used for winter footwear; sealskins are used for summer. When bearded sealskin is available locally or through trade, this large, thick skin is often used for boot soles needed for all seasons. Caribou or reindeer bull skins are used for soles when extra insulation is needed. These soles are less durable than bearded sealskin but provide much greater insulation. For example, hunters or fishers wearing footwear with caribou or reindeer soles can stand all day on the ice waiting for a seal or fish without getting cold feet. Caribou- or reindeer-leg skins are sewn together to make leg sections for boots. These skins last many years, the soles are replaced as they wear out, and the leg sections reused.

Sealskins are either left with the hair on or de-haired by shaving (produces a black skin) or rubbing the hair off (produces a yellowish skin). Some skins are dried and hung outside in the early spring sun to be bleached white. Black



**Koriak fur boots.** Boots are worn year round by Inuits and are usually made from sealskin, with the hair left on in the winter for added warmth. © RICK RIEWE. REPRODUCED BY PERMISSION.

and yellowish skins are used for waterproof or water-resistant boots, white skins are used in the winter for cold, dry conditions. Some boots are made from sealskins, which are first made into a bag used to store seal fat. Once all the fat is used the bag is reused to store wild berries mixed with fat. Once that is eaten, the bag is fully impregnated with oils and used to make waterproof leg sections on boots used in unfrozen wet areas during the winter.

Other skins used in footwear include a wide variety of species used for the leg sections, including black bear, brown bear, polar bear, wolf, wolverine, fox-leg skins, sea otter, moose, elk, fish, bird, muskrat, beaver, musk ox-leg skin, mountain goat, and mountain sheep. In the early 2000s, some women also use fabric for leg sections.

### Technology

Footwear is made from pieces measured using a complex hand-span system passed down from one generation to the next. Pieces are cut out of skins in a preplanned manner that makes the best use of the skin grain, skin thickness, hair color, and hair direction. They are sewn together using animal sinew or artificial sinew and a steel needle and thimble. Traditionally, bone or stone needles and skin thimbles were used. In most cases an overcast or running stitch is used. On some seams a waterproof

stitch is used to ensure the boot stays waterproof. When sewing this stitch, the needle penetrates all the way through one skin and only partway through the other skin. The work is then turned over and reewn with the needle going all the way through the second skin and partway through the first skin, preventing the seamstress from making a hole through all layers in any one place.

In Greenland, elaborate skin embroidery is applied around the top of the leg section. This is done by removing the hair from sealskin, bleaching the skins, and then painting them with bright colors. These skins are then cut into very narrow, straight strips and stitched to the leg section. Once it is stitched in place, the strip of skin is cut, allowing the seamstress to sew much smaller pieces than if she had cut the pieces first and then tried to stitch them in place. Many different-colored skins are used for skin embroidery. Today few seamstresses make this type of footwear; they usually purchase these boots from a local business.

### Conclusion

Footwear and clothing used throughout the circumpolar region has several common characteristics in that it is generally made from caribou and sealskin, protects individuals from the weather and terrain, and enables seamstresses to communicate to their helping spirits. In addition, footwear and clothing depicts the relationship individuals and groups have to their local environment within the distinct cultural frameworks throughout the circumpolar region.

See also **Boots; Inuit and Arctic Dress.**

### BIBLIOGRAPHY

- Oakes, Jill and Rick Riewe. *Spirit of Siberia: Traditional Native Life, Clothing, and Footwear*. Washington D.C.: Smithsonian Institution Press, 1998.
- . *Our Boots: An Inuit Women's Art*. New York: Thames and Hudson, Inc., 2000.
- Oakes, Jill et al. *Pushing the Margins: Native and Northern Studies*. Manitoba, Canada: University of Manitoba, 2001.

Jill Oakes

## IRAN, HISTORY OF PRE-ISLAMIC DRESS

Our knowledge of dress in pre-Islamic Iran comes from pictorial depictions mainly on rock reliefs, metalwork (including coinage), seal impressions, and, from about the second century C.E., wall paintings. Information is fragmentary and episodic, and relates to the ruling households, the military, divinities, and occasionally priests; depictions of women (even female goddesses) are rare.

### Elamite Dress (c. 2750–653 B.C.E.)

In its heyday the Elamite empire controlled the region from eastern Mesopotamia to central Asia and Pakistan,

but after 1100 B.C.E. its political influence waned. Early Elamite cylinder seals show bearded men (possibly princes or priests), wearing multi-layered skirts—perhaps of hanging feathers, leather strips, or sheepskin—similar to those found in certain votive statues from Mari (an ancient Syrian city), and clay tablets reveal that wool and flax were being exported to neighboring lands. A few seals (c. 2200–1600 B.C.E.) include female figures wearing similar but fuller skirts. However, a bronze statue (now in the Louvre) of Queen Napirasu (d. 1333 B.C.E.) from Susa shows a diagonally necked bodice with elbow-length sleeves, a long, bell-shaped skirt with wide decorated bands around the hips and down the left front, fabric flaps on the right hip, and a deep fringe (possibly of sheep wool) around the hem. Later Elamite rock reliefs (e.g., Kuh-i Farah, c. 800 B.C.E.), although seriously eroded, record ankle-length, long-sleeved robes worn with projecting shoulder collars.

### Achaemenid Dress (c. 550–330 B.C.E.)

The Persian Achaemenid family triumphed over the Medes of northwest Iran, seizing land stretching from the Balkans to the Tian Shan mountains in central Asia and China, until its destruction by Alexander the Great. The ceremonial capital of Persepolis provides most costume pictorial evidence; scholastic opinion is divided regarding whether details on the so-called Oxus Treasure (British Museum) and surviving clothing from other central Asian sites such as Pazyryk should be considered Iranian Achaemenid or central Asian dress.

The Persepolis reliefs and the Susa tile revetments (Louvre) reveal nothing of women's and children's dress but show two distinct male costumes: the "Median" dress of long trousers tucked into ankle boots, a tunic under a knee-length, a long-sleeved coat (*kandys*) draped over the shoulders, and a rounded soft cap encircled by metal fillet; and the "Persian" dress of an ankle-length, draped skirt, a top with four deep pleats at the elbow, and a tall, fluted cap (possibly of feathers or padded felt). It is this latter garment that has provoked discussion. Rejecting a theory from the 1930s that the garment was made of an unseamed rectangle of fabric folded on the shoulders and belted to form drapery folds, Anna Roes argued for a sophisticated construction of two separate pieces: a waist-length cape with a triangular insert at the elbow creating four sleeve pleats, and a sari-like skirt with hanging fabric bands down the front, back, and sides. Two decades later, P. Beck (1972) proposed another structure based on two lengths joined at the shoulder, both differently cut to produce the curves and pleats of the distinctive sleeves. Neither theory is entirely satisfactory regarding the skirt as detailed on seated figures. At court, men's hair was worn behind the ears to shoulder-length, tightly curled, while the beards (which may have been false) were carefully arranged into ringlets, interrupted by rows of tight curls.

**Parthian or Arsacid Dress (c. 250 B.C.E.–224 C.E.)**

The various Silk Roads crossing Asia flourished in the Parthian period, bringing Chinese silk to the West in exchange for horses, wool, and linen. Short-staple cotton was perhaps being cultivated in eastern Iran but was available from east Africa and the Persian Gulf regions. Most detailed information about the dress from this period is gleaned from pictorial art from the ancient cities Palmyra, Dura Europos, Hatra, and Nimrud Dag—as well as from central Asian regions of ancient Syria, ancient Iraq, and ancient Anatolia—but modern specialists in these regions often evaluate such clothing as “national” rather than Parthian “imperial” dress.

The man of rank wore a hip- or thigh-length belted tunic with narrow, long sleeves, although the Palmyran sculptures show a long fabric tie, knotted and looped. There were various methods of fastening tunics, possibly denoting differences in rank, status, or, perhaps, office: wide diagonal openings right to left, small and deep rounded necks, square necks, and extended neck lapels fastening below the front left shoulder. The tunic sometimes had heavy drapery folds forming a U-shaped apron, and a long-sleeved, calf-length, narrow-fitting jacket was worn over this. Loose trousers, often heavily patterned and banded down the center of the leg, were gathered at the ankle or into calf-length boots. A long folded stole, or strip of silk, on the left shoulder, shown on figures in some images, may indicate priestly attire. Regarding head covering, gods, kings, and generals (as those at Hatra and Nimrud Dag) are shown with tall helmets with a narrow front profile, decorated with “pearl” beading.

Information regarding female attire is sparse. The Greek *chiton* is said to be the inspiration behind the Palmyran dress, but ladies’ bodices in Khaltchyan wall-reliefs are close-fitting with a deep or shallow neck, with additional material flaring from the breast band. Below this a trailing pleated skirt was worn, and a long, wide stole covered the shoulders or was draped over the arms.

**Sasanid Dress (224–658 C.E.)**

From the fifth century, Iranian cotton was being exported to China along with linen flax and wool. Chinese imperial histories record that silkworms were smuggled into central Asia in 419 C.E., but the Arab histories and Iranian poetry suggest sericulture was established in Sasanid lands around 300 C.E.. Draw-loom technology was known from eastern Mediterranean lands, but most dress fabrics were still made on the narrow back-strap loom. Tapestry (slit) weave and compound twill weave are mostly associated with Sasanid wool and silk dress fabrics, respectively.

The rock carvings near Shiraz show shahs in fitted bodices, perhaps of molded leather, together with full-length trousers or chaps with long wavy curls of either sheepskin or very fine fabric. By the mid-fourth century a draped apron-like tunic, reaching to the lower calf in

front, was worn, and some later silver dishes depict another type of tunic with stiffly pointed side corners. By the late fifth or early seventh century—depending on the date of a carving at Taq-i Bustan—the royal dress was a long-sleeved, knee-length tunic in heavily patterned woven silk, or decorated with padded appliqué forms; the belt had hanging lappets signifying status (the more numerous, the higher the rank). A double row of beading decorated the central front fastening, neck, cuffs, and hem edges. Underneath, ample trousers were gathered into soft ankle boots fastened with long ribbon ties. Each shah wore a distinctive crown often incorporating a large “balloon” (possibly of hair), while princes and generals had tall caps with a slight Phrygian curve ending in a bird or animal head, or decorated with a stylized emblem.

A few images of the Zoroastrian goddess, Anahita, and court entertainers provide most information about women’s dress. In a late-third-century relief at Naqsh-e Rostam, Anahita has an ankle-length robe, falling in diaphanous folds and girded by a creped ribbon belt. However, at Taq-i Bustan, carved at least 150 years later, her long-sleeved robe falls from a shoulder clasp with a sleeved coat (possibly felt) draped over her shoulders. Her tall, tasseled headdress is more elaborate than those of female musicians in the hunting compositions beneath. On Sasanid metalwork female dancers are noticeable for their long stoles draped across the front at hip level. In the rare depictions of royal ladies, the dress is similar to those of Anahita, while the children wear miniature versions of the regal ensembles.

In Sasanid times, Zoroastrianism was officially promoted, and Zoroastrian priestly dress was probably formalized in this period. Ritual regulations concerning the lambswool *kusti* (girdle) and cotton *sudra* (shirt), worn by all adult believers, were also probably codified during this period.

See also **Islamic Dress, Contemporary; Middle East: History of Islamic Dress.**

**BIBLIOGRAPHY**

- Beck, P. “A Note on the Reconstruction of the Achaemenid Robe.” *Iranica Antiqua* 9 (1972): 116–122. Refers to earlier garment-structure theories, with bibliography.
- Colledge, Malcolm A. R. *The Parthian Period*. Leiden, Netherlands: Brill, 1986. Best illustrative overview, with good bibliography.
- Fukai, S., and K. Horiuchi. *Taq-I Bustan*. Volume 2. Tokyo: Yamakawa Publishing Company, 1972. Detailed photographs but not comprehensive as it omits lower “hunting” reliefs carved in main grotto.
- Herrmann, G. “The Daragird Relief.” *Iran* 7 (1969): 63–88. Argument concerns identification of shahs and gives clear drawings of most Sasanid rock reliefs. Contains useful bibliography.
- Hofkunst van die Sassanieden*. Brussels: Koninklijke Musea voor Kunst en Geschiedenis, 1993. An exhibition catalog. Excellent illustrations of Sasanid art including helmets, textiles, metalwork, and full bibliography.



Potts, Daniel T. *The Archaeology of Elam: Formation and Transformation of an Ancient Iranian State*. New York: Cambridge University Press, 1999. Little accessible information on dress but comprehensive bibliography.

Roaf, M. "Sculptures and Sculptors at Persepolis." *Iran* 21 (1983). Entire issue devoted to this topic; good illustrations and drawings with thorough bibliography.

Roes, A. "Achaemenid Influence Upon Egyptian and Nomad Art." *Artibus Asiae* 15 (1952).

Patricia L. Baker

**IRIBE, PAUL** Paul Iribe (1883–1935) was born in Angoulême, France. He started his career in illustration and design as a newspaper typographer and magazine illustrator at numerous Parisian journals and daily papers, including *Le temps* and *Le rire*. In 1906 Iribe collaborated with a number of avant-garde artists to create the satirical journal *Le témoin*, and his illustrations in this journal attracted the attention of the fashion designer Paul Poiret. Poiret commissioned Iribe to illustrate his first major dress collection in a 1908 portfolio entitled *Les robes de Paul Poiret racontées par Paul Iribe*. This limited edition publication (250 copies) was innovative in its use of vivid fauvist colors and the simplified lines and flattened planes of Japanese prints. To create the plates, Iribe utilized a hand-coloring process called *pochoir*, in which bronze or zinc stencils are used to build up layers of color gradually. This publication, and others that followed, anticipated a revival of the fashion plate in a modernist style to reflect a newer, more streamlined fashionable silhouette. In 1911 the couturier Jeanne Paquin also hired Iribe, along with the illustrators Georges Lepape and Georges Barbier, to create a similar portfolio of her designs, entitled *L'Eventail et la fourrure chez Paquin*.

Throughout the 1910s Iribe became further involved in fashion and added design for theater, interiors, and jewelry to his repertoire. He continued to illustrate fashion, opened a store of decorative art on the rue du Faubourg St.-Honoré in Paris, and created textiles for the firm Bianchini Ferrier and for designer André Groult. His association with the theater resulted in several publications related to the renowned dancer Vaslav Nijinsky, including the album *Prélude à l'après-midi d'un faune*, which captured Nijinsky's choreography for the Claude Debussy composition in photography by Adolph de Meyer.

Iribe is perhaps best recognized for his contributions to the *Gazette du bon ton*. Started in 1912 by the publisher Lucien Vogel, the fashion journal featured the creations of the top couture houses illustrated by the leading visual artists of the day, including Iribe, Georges Barbier, Georges Lepape, A. E. Marty, and Charles Martin. Like Iribe's earlier work, the magazine was a deluxe limited-edition journal. The publication included between eight and ten *pochoir* plates in each issue and helped position fashion graphics as a modern medium. While the *Gazette*

*du bon ton* slowed its publication during World War I, it resumed putting out monthly editions from the end of the war until 1925, and a total of sixty-nine issues were printed. In 1925, the publisher Condé Nast purchased the *Gazette* and it merged with *Vogue*.

In 1919 Iribe moved to New York, and his art deco style was further disseminated to the American fashion-buying public through his continued work in fashion illustration and interior design. His work was published in seven issues of American *Vogue*, and he also opened a store on Fifth Avenue called Paul Iribe Designs New York–Paris. Iribe was one of the first French fashion figures to work in Hollywood. Cecil B. DeMille commissioned him to create clothing for Gloria Swanson in the 1919 film *Male and Female*. This film marked the beginning of a six-year collaboration with the Hollywood studio, during which Iribe acted as artistic director for eight DeMille films.

Iribe moved back to France in 1930 and became involved in numerous design projects, including the publication of *Choix*, a book that showcased his designs for furniture, decorative arts, and jewelry. He continued to design jewelry, working with Coco Chanel in 1932 to create a line that her couture house produced. In 1933 Iribe was awarded *la Légion d'honneur* for his work as an artist-illustrator. He died of a heart attack in 1935 at Chanel's villa in Roquebrune Cap Martin, France.

See also **Art and Fashion; Art Nouveau and Art Deco; Dance and Fashion; Fashion Illustrators; Fashion Magazines.**

#### BIBLIOGRAPHY

Lelieur, Anne-Claude. *Paul Iribe: Précurseur de l'art déco*. Paris: Bibliothèque Forney, 1983.

Mackrell, Alice. *An Illustrated History of Fashion: 500 Years of Fashion Illustration*. New York: Costume and Fashion Press, 1997.

Robinson, Julian. *The Golden Age of Style: Art Deco Fashion Illustration*. New York: Harcourt Brace Jovanovich, 1976.

Michelle Tolini Finamore

**ISLAMIC DRESS, CONTEMPORARY** For both insiders and outsiders, dress is often at the center of debates concerning how Muslims should live in the rapidly changing, globally interconnected world of the early 2000s. Should women cover their heads? Is the *hijab*, the veil, a sign of oppression or a symbol of liberation? Who decides what Muslims should wear? Are Western styles of dress appropriate? Are they necessary for modernization? And what is acceptable for Muslims living in the West?

Islamic dress is layered with overt and subtle symbolic meanings. Many individual men and women dress as Muslims for the purpose of showing their devotion to God. The word Islam means "submission"—not to the religion itself, but to the guidance and will of God. A

Muslim, therefore, is literally “one who submits,” and Islamic dress displays that commitment. At the same time, specific styles of dress have been shaped by other factors such as climate, cultural aesthetics, economics, trade patterns, and political ideologies.

The “five arkan,” or pillars, of Islam have fundamentally shaped what Muslims believe and practice, including how they dress. These pillars include the *shahada* (a declaration of faith that “there is no god but God and Muhammad is the prophet of God”), *salat* (five daily prayers), *zakat* (the giving of charity; which is sometimes regarded as a religious tax), *Sawm* (the annual month of daytime fasting known as Ramadan), and the *Hajj* (the pilgrimage to Mecca). Cleanliness of the body and clothing is highly valued. Muslims must wash their face, hands, and feet before prayer. Loose clothing makes it easier to bow and kneel. Men and women who have completed the *Hajj* are called “Hajji” or “el-Hajj” and frequently wear garments that display their new status. There is also a special form of dress called *ibram* that is worn during the pilgrimage. For men, this consists of two lengths of white cloth that are wrapped around the upper and lower body. Women on the pilgrimage are expected to wear a simple form of dress from their own culture. One of the major purposes of *ibram* is to eliminate the display of rank and wealth. This is a reflection of the philosophy that all Muslims are equal before God.

Detailed discussions about the five pillars are provided in the Qur’an (believed to be the literal word of God), the *hadiths* (sayings and traditions of the prophet Muhammad), and codes of *Shari’ah* (Islamic law). Unlike the Catholic church, there is no central authority in Islam. Muslims often follow the pronouncements of reli-



#### A COMMON INTERPRETATION OF ISLAMIC DRESS

- Men and women should not dress the same
- Clothing should not be tight or reveal the form of the body underneath
- The design, texture, or scent of clothing should not attract undue attention
- A man should cover his body from knees to navel
- A woman should cover everything except for her hands and face
- These rules for men and women apply in public places and private gatherings where both men and women are present; bodies are not for display
- Modesty is appropriate at any age, but particularly important after a girl or boy has reached puberty



#### DRESS AND THE REJECTION OF WESTERN INFLUENCES

“A Muslim who wears Western dress cannot but betray his preference for Western civilization and all it stands for. If a man truly loves Islam, is it not logical that he should express that love in his physical appearance?” (Samuillah, pp. 24–25)

gious scholars and leaders, but there is no barrier for individuals who want to study the religion for themselves. There are many different interpretations about the “correct” practice of Islam in everyday life, including how Muslims should be dressed. Many choose to adopt practices that are *sunna* (meaning “encouraged” in religious law as well as “following the path of the prophet Muhammad”) and avoid practices that are *haram* (“forbidden” or “dirty”). It is considered *sunna* for men to grow a beard and dye it with henna. Devout men avoid wearing silk and gold, including anything dyed yellow (because it might look like gold). Women avoid wearing perfume that contains alcohol, which Muslims are also not allowed to drink.

Often, these ideals are tempered by more worldly concerns. Although beauty is closely connected with *haya* or “modesty,” some simple forms of dress are actually very expensive. In oil-rich states around the Persian Gulf, women from wealthy families can buy a designer Islamic dress that looks modest but costs hundreds of dollars. Under these layers of clothing (or at private parties segregated by gender) they might also wear couture from Europe. Some fashion houses, such as Chanel and Dior, have many clients in the Middle East. In communities where people are not as wealthy, there are often other forms of dress—such as the *chaadaree*, or *burqa*, in Afghanistan—that can be worn to display a higher level of social and economic status. Clothing that covers a woman from head-to-toe is not only costly but makes it physically difficult for her to perform manual labor. Many families cannot afford the expense or loss of income. This is equally true in the United States and Europe, where discrimination against women who are visibly Muslim can make it difficult to hold a job outside of the home.

#### Forms of Dress

In the Middle East, the most common form of dress for men consists of several layers of clothing including trousers, a *disbdasha* (an ankle-length shirt that buttons down the front), and a cloak called an *aba* or *abaya*. This outermost layer is usually white or brown and is worn

with a close-fitting cap called a *kufi*. Over this, men wear a loose head covering known as a *ghutra* that is held in place with a thick cord called *agal*. The *agal* once had a functional purpose (used by Bedouins for tying the legs of camels together), but is now manufactured specifically as an item of dress. Women also wear the *abaya*, but this outer layer is frequently black or gray. Other items of dress vary depending upon the location. Since the Iranian Revolution in 1979, women in that country have been required to wear a head covering and are encouraged to wear the *chador*, a waist-length (or longer) tailored garment that fits closely around the face. In Saudi Arabia, many women wear a *niqab* (a kind of veil), along with dark gloves and socks, leaving only their eyes visible in public. In Oman and the United Arab Emirates, women traditionally wear a mask (also called *niqab*) that covers the face but leaves the hair and neckline showing. This practice is falling out of favor, as many young women prefer to wear the *chador* or the style of *niqab* that is common in Saudi Arabia. These forms of dress are generally made out of wool or cotton cloth and are not only modest but offer protection from the piercing sun and blowing sand.

In Palestine, Syria, and Turkey, many women wear a head covering called *kbimar*. This is simply a large triangle of cloth (or a square folded into a triangle) that covers the head and is wrapped around the neck or pinned under the chin. A new style of *kbimar* that is easy to wear (particularly for children) is sold in packages of two pieces. The first one covers the hairline; the second one fits under the chin and covers the head and shoulders. This head covering is often worn with a buttoned overcoat called the *jilbab*, or *jellabib*.

Among Muslim women in Malaysia, Indonesia, and East Africa (including immigrants from these areas who live in the United States and Europe), the *jilbab* is used as a plain, “Arab” style of dress that covers the entire body except for the feet and hands and fits closely around the face. For men, a garment that has spread from the Middle East to many parts of the world is the *kaffiyeh*, a black-and-white or red-and-white checkered shawl that can be draped over a shoulder, wrapped around the head as a turban, or secured over the head with an *agal*. In the West, the *kaffiyeh* is one of the most recognizable symbols of Islam, worn by many political leaders including Yassir Arafat.

In Pakistan and India, men and women wear *salwar kameez*, loose pants covered by a long shirt. This style of dress is originally from Persia. Women also wear the *dupatta*, a long piece of cloth that can be draped over a shoulder or wrapped around the head and body depending on the situation. Men cover their heads with a turban. Many of these items are lightweight and made out of silk, cotton, or a synthetic material like polyester—practical for a hot and humid climate. Unlike clothing in the Middle East, these textiles can be very colorful.

In North and East Africa, religious men often wear headgear, such as a turban or *kufi*, particularly for communal prayers on Friday. (In the United States, many African American Muslim men wear just the *kufi* along with more ordinary Western clothing.) Women in Tanzania, Kenya, and Somalia wear colorful cotton textiles imported from India. These are sold in lengths of six to ten yards that are later cut into pieces—one for a long, loose-fitting dress, and one that is draped over the head and around the shoulders (respectively called *dirac* and *garbasaar* in Somalia). In Morocco, Algeria, and Tunisia, men wear a *burnoose*, a loose cloak with a hood unique to that area. In West Africa, men and women both wear a long, simple gown known by various names including *boubou*, *bubu*, and *baba riga*. Women are not expected to cover their heads, but many do wear a piece of wrapped cloth to signify that they are married. Coverings similar to the *dupatta* and *garbasaar* are limited to use by women who have completed the *Hajj* or live in Niger, northern Mali, and Mauritania, or other areas where many communities have begun to enforce Islamic law. In rural areas of East and North Africa, southern Arabia, and Central Asia, where many people still live a nomadic or semi-nomadic lifestyle, it is also not uncommon for women to go without a head covering.

### Political and Economic Context

Over the last century, the Islamic world has gone through many dramatic changes—the discovery of oil (“black gold”) in the Middle East and Southeast Asia; the introduction (and sometimes rejection) of Western-style education, markets, technology, and dress; a series of revolutions and wars; and a rapid expansion in population. Although the Islamic religion began in the Middle East, in the early 2000s there are far more Muslims outside that area, in countries such as Pakistan, India, Indonesia, and China. The total number of Muslims has grown to more than 1 billion people.

The production and sale of oil has given some countries incredible wealth. In Brunei, Bahrain, Qatar, and the United Arab Emirates, there are no personal income taxes. Education and health care are provided free of charge. A number of governments have used oil money to build roads, irrigation systems, universities, and other public buildings—sometimes not just for the nation, but also for Muslims in other parts of the world. Farmers, laborers, teachers, and doctors from Egypt, East Africa, and South Asia have been drawn to the Middle East for jobs that pay much more than similar positions at home. Although the media is often closely monitored for sexual and political content, many people have access to videos, satellite television, and the Internet. The Arab television network Al-Jazeera competes with CNN and the BBC.

At the same time, there have been downsides to this economic windfall. Long-standing relationships and tensions that began when Great Britain and France colonized many parts of Africa, Arabia, and South Asia have



intensified. The United States has been involved in two wars with Iraq and built or used military bases in Kuwait, Saudi Arabia, Turkey, Afghanistan, and Djibouti. Oil money has brought a new wave of entrepreneurs and professionals from Europe and the United States. In Cairo, anthropologists Elizabeth and Robert Fernea have observed that colonization and contacts with the west have been accompanied by social changes that many Muslims (not only the fundamentalists) have found objectionable.

Along with our technology go our sales techniques, administrative methods, ideas about investment and economic growth . . . [as well as] rock music, bars and nightclubs full of alcohol and fashionably dressed women. . . . [This is often viewed as] the loss of Egyptian, Arab, and/or Muslim ways of life—a shameful loss of independence, respectability, and honor (p. 440).

In the early 1900s, many Egyptian feminists adopted Western dress and removed their veils as a sign of liberation. In the early 2000s, a new generation has returned to covering their heads. This practice offers some protection from sexual harassment on overcrowded city streets and buses, but it also signals a resurgence of pride in Islam and Islamic practices in everyday life.

In the late 1800s and early 1900s, people in many parts of the Islamic world turned to religion as a source of guidance and unification in their efforts to resist colonization. Remnants of these movements, such as Wahhabism in Saudi Arabia and Mahdism in the Sudan, still exist. Similar approaches are reemerging as a response to cultural and military invasion and to counteract the excesses of globalization. In Afghanistan, where the population has been involved in continuous warfare for more than two decades, the Taliban made an effort to establish order by imposing a very strict interpretation of Islamic law. Girls were forced out of schools; professional women were dismissed from their jobs, required to wear the *chaadaree*, or *burqa*, and could appear in public only if accompanied by a male relative. Many feminists in the West were horrified by these practices and circulated petitions over the Internet begging the Taliban to stop. During the invasion of Afghanistan after 11 September 2001, the United States government and media networks made use of these sentiments by citing the “liberation of women” as one justification for overthrowing that regime.

A more moderate version of political Islam is gaining support from both intellectuals and ordinary citizens in many countries. In Turkey, where the government has tried to “modernize” the nation by banning Islamic dress in public buildings, women who are sympathetic to the Islamist movement have been forced to leave universities and even elected positions in Parliament for expressing their religious and political beliefs through dress. In France, the children of immigrants from Turkey and North Africa have sometimes been expelled from public schools for violating a strict separation of church and state by wearing head coverings. Unfortunately, many

people view Islam (and Islamic dress) as being incompatible with democracy. This has become a very sensitive issue in Turkey as that country is trying to become part of the European Union.

Outside of the Middle East—in areas such as Malaysia, Indonesia, and Somalia—men and women are beginning to wear the *kaffiyeh* and *jilbab* to signal that they are looking to Islam for social and political change. In Malaysia and Indonesia, the government has provided money to build mosques and support religious education, but political Islam is forbidden. Approximately 15 percent of Indonesians are Hindu, Catholic, or Protestant (a designation that must be recorded on official documents such as a driver’s license), but there are also more than 180 million Muslims—the largest number of Muslims in a single nation (Farah, p. 273). Indonesia has oil resources and is a member of OPEC, but millions of people live in absolute poverty. Some would like to replace what they view as a corrupt government with one founded on Islamic principles. In East Africa, Somalia has been in a state of chaos since the last government collapsed during a civil war in 1991 without being replaced. Some Somalis would like to initiate a new government based on Islamic law. Others see this as “Arabization”—a non-Somali influence from the Middle East. The rebuilding of that government is complicated by internal differences as well as accusations from Ethiopia and the United States that Somalia is a harbor for terrorists.

The events following September 11th—including the passage of the Patriot Act and military action in Afghanistan and Iraq—have brought intense scrutiny to Islam and Muslims. The visibility of Islamic dress has led many women in particular to feel they must make a choice between personal safety and religion. A report by the Council on American-Islamic Relations notes that many Muslims have been effected by religious and ethnic profiling in public places and at airports, often based on their dress. “The experiences of Muslims in the post–September 11 climate have been unmatched by any previous period. . . . A Muslim woman from Lincoln, Nebraska, was ordered to remove her *bijab* [head covering] before boarding an American Airlines flight. She was frightened by the guard with a gun, so she complied” (pp. 4–5).

At the same time, the number of Muslims in the United States is continuing to grow through immigration as well as conversion. For many people, these difficult times have renewed their sense of commitment to the religion and religious dress. An awareness of Islam in the general public is also growing as more people than ever read books and attend lectures in an effort to gain a better understanding of what is going on in the world.

See also **Burqa; Ethnic Dress; Jilbab; Middle East: History of Islamic Dress.**

#### BIBLIOGRAPHY

Abbas. *Allah O Akbar: A Journey Through Militant Islam*. London: Phaidon Press Ltd., 1994.

- Arthur, Linda, ed. *Undressing Religion: Commitment and Conversion from a Cross-Cultural Perspective*. Oxford: Berg, 2000.
- El Guindi, Fadwa. *Veil: Modesty, Privacy and Resistance*. Oxford: Berg, 1999.
- Farah, Caesar E. *Islam: Beliefs and Observances*. 7th ed. Hap-pauge, N.Y.: Barron's, 2003.
- Fernea, Elizabeth W., and Robert A. Fernea. *The Arab World: Forty Years of Change*. New York: Anchor Books, 1997.
- Haddad, Yvonne Y., and John L. Esposito, eds. *Muslims on the Americanization Path?* Oxford: Oxford University Press, 2000.
- Khan, Maulana W. *Women in Islamic Shari'ah*. New Delhi, India: The Islamic Centre, 1995.
- Lindisfarne-Tapper, Nancy, and Bruce Ingham, eds. *Languages of Dress in the Middle East*. Surrey, U.K.: Curzon Press, 1997.
- Samiullah, Muhammad. *Muslims in Alien Society: Some Important Problems with Solution in Light of Islam*. Lahore, Pakistan: Islamic Publications, 1982.

#### Internet Resource

- The Status of Muslim Civil Rights in the United States*. Washington, D.C.: Council on American-Islamic Relations Research Center, 2002. Available from <http://www.cair-net.org/civilrights2002/civilrights2002.doc>.

Heather Marie Akou

**ITALIAN FASHION** During the Renaissance, Italian city-states such as Florence were centers of fashion innovation. For centuries thereafter, however, Paris dominated the world of fashion. Of course, fashions were produced in Italy during that time, but they were usually derivative of French styles. Only since the 1950s has Italy achieved its own independent identity as a source of fashionable clothing for the rest of the world.

The emergence of the "Italian look" drew on important historical advantages, such as the existence of fine craft traditions in textile production, luxury leather goods, high-quality tailoring, and other trades crucial to the fashion system. The artistic textiles and garments of Mariano Fortuny were well known internationally in the decades before World War II, as were the superb men's woolen suiting fabrics woven by Ermenegildo Zegna and fine accessories made by Ferragamo and Gucci. Still, it is symbolic of Italy's relative invisibility on the international fashion scene that Italy's most famous prewar designer, Elsa Schiaparelli, was based in Paris.

Modern Italian fashion first came to international prominence with the rapid post-World War II war reconstruction of the textile industry and the rise of ready-to-wear clothing production, as Nicola White documents in her important book *Reconstructing Italian Fashion*. The postwar rise of Italian fashion was not accidental. A number of Italian manufacturers, with the support of the Italian government, made a systematic effort to create an

export-oriented fashion industry that would play a significant role in Italy's postwar economic reconstruction. Beginning in 1949 fashion shows designed to emphasize Italy's heritage of art and culture were staged to capture the attention of foreign journalists. In July 1951 a pivotal fashion show in Florence attracted almost two hundred American buyers and journalists, along with another hundred from Italy and elsewhere in Europe. Soon journalists and department store buyers attending the Paris fashion shows began to take the train down to Florence. There, fashion presentations were conceived, in part, to cater to the demand for creatively constructed, well-made ready-to-wear combining distinction and informality, adapted to the American fondness for sunny weather and colorful, affordably priced garments. Originally, the Italian *alta mode* (couture) houses also showed in Florence, but soon the couturiers for a variety of reasons began to show instead in Rome, where many of them were members of Roman society. There they organized and presented their own singular creations for *la dolce vita*.

American journalists enthusiastically promoted "the Italian Look," identifying it with casual yet aristocratic elegance. Italian designers were said to have a special knack for resort wear; capri pants, sandals, gold jewelry, and chic sunglasses were essential elements of Italian style. Italian fashion offered an appealing (and less expensive) alternative to the more formal Paris couture.

The commercial and cultural relationship between Italy and America played an important role in the postwar development of Italian fashion. One manifestation of this was the close connection between the worlds of film and fashion. For example, the Fontana Sisters, who had opened their couture house in Rome in 1944, became closely associated with Hollywood glamour. Ava Gardner wore Fontana dresses in the 1953 film *The Barefoot Contessa*. Other film stars, including Audrey Hepburn, Elizabeth Taylor, and Kim Novak, wore Fontana Sisters evening dresses, and Margaret Truman was married in a Fontana Sisters wedding dress in 1956. Also important in the glamorous world of film was Emilio Schuberth, who was born in Naples in 1904 and opened a couture house in Rome in 1938. Among his clients were Gina Lollobrigida and Sophia Loren.

Emilio Pucci entered the fashion business in 1948 and quickly became known for his kaleidoscopic textile designs, which were made up into "featherweight" jersey scarves, shirts, and other separates. Pucci helped establish the reputation of Italian designers for easy, comfortable, body-conscious clothing. His brightly colored fashions were part of a broader range of Italian products, such as Vespa motor scooters and Olivetti typewriters, that became icons of modern style. By the early 1960s, it was clear that Italy had changed the way the world looked; the word "Italian" had become synonymous with "good design."

Another important Italian designer was Roberto Capucci, born in 1930, who opened his own atelier in Rome

in 1950 and quickly gained a reputation as a master of both silhouette and color. Capucci approached his work as an artist, pleating and manipulating fabric into fluid, sculptural forms. Probably the single most important and successful Italian designer to emerge during the 1960s was Valentino. Valentino Gavarri studied couture in Paris before opening his own *alta moda* house in Rome in 1960; his career now spans more than four decades. He designs both ready-to-wear and couture, and is known for his fondness for brilliant red fabrics. His opulent gowns have appealed to many celebrities, from Sophia Loren to Gwyneth Paltrow, but his most famous client was Jacqueline Kennedy, who wore a lace-trimmed Valentino dress for her marriage to Aristotle Onassis.

The Italian Look that had such a profound impact on women's fashions extended to men's wear as well. Even before World War II, Italy had an international reputation for the highest quality bespoke shirts and men's accessories. By the 1950s, tailoring firms such as Brioni created the "Continental look" in menswear. Italian tailors created luxurious, body-conscious suits that offered a clear alternative to the dominant Ivy League look of American men's wear and the traditional styles of London's Savile Row.

The persistent, unresolved competition between Florence and Rome, each with its own schedule of fashion shows, contributed to the rise of Milan, which emerged in the 1970s as the center of Italian fashion for both men and women. Some of the most innovative Italian houses, including Krizia and Missoni, shifted their collections to Milan, as did the influential stylist Walter Albini, who designed for several different firms that showed in Milan, as well as producing clothing for his own label.

A northern Italian industrial city, Milan lacked the historic allure of Rome and Florence, but was able to draw on the established Italian tradition of fine textiles. Textile producers in northern Italy provided financial backing to Italian clothing manufacturers who showed in Milan. Moreover, Milan was known for modern product design, and *Vogue Italia* had been published there beginning in 1961. The rise of a ready-to-wear clothing industry was a natural consequence of these circumstances. Two designers in particular rose to prominence and worldwide fame in this milieu: Giorgio Armani and Gianni Versace.

Armani revolutionized men's wear in the 1970s, creating unstructured jackets that were as comfortable as sweaters and that radiated an air of seductive elegance. Armani's clothes were prominently featured in the 1980 film *American Gigolo*; by 1982 his picture was on the cover of *Time* magazine. His women's wear was also characterized by an easy elegance and luxurious minimalism. Meanwhile other Italian firms long known for fine fabrics and superb workmanship, such as Ermenegildo Zegna, also benefited from the rise of Italian tailoring to

a position of world leadership from the 1970s onward.

Very different from Armani was Gianni Versace, who founded his own label in 1978. Where Armani emphasized understated luxury, his rival Versace grounded his designs in an aesthetic of flamboyance and display; he produced, for both men and women, some of the most sexually expressive clothing ever made within the mainstream of fashion. After Gianni Versace was murdered in 1997 in Miami, his sister Donatella became the company's head designer. Having collaborated closely with her brother for many years, she was able to build on his aesthetic, while also making her own contributions to the Versace style. Popular music, for example, had always been a passion of Gianni's, but became even more central to Donatella's style. Her body-revealing and consciously outrageous dresses, worn by top singers and actresses, became by the early 2000s an eagerly awaited feature of the annual Oscar and other entertainment business award ceremonies.

Franco Moschino was overshadowed commercially by Armani and Versace, but his witty send-ups of the fashion system were popular with women who wanted to be seen as stylish but not as "fashion victims." Other important Italian designers of the late twentieth and early twenty-first centuries include Romeo Gigli; Gianfranco Ferré; knitwear designer Laura Biagiotti; and Renzo Rosso, founder of the irreverent sportswear firm Diesel.

Among the most remarkable success stories of Italian fashion in the late twentieth century are the revival of Gucci under the direction of the American Tom Ford, the rise of the firm of Prada, and the impact of Dolce & Gabbana. After Miuccia Prada took charge of her grandfather's small, respected leatherwear firm in the 1980s, it burgeoned into an international phenomenon in accessories, shoes, and clothing. Her first big success was a black nylon backpack with a triangular silver label that became a must-have cult item among fashion-conscious women. By the mid-1990s, Prada bags and shoes were setting the international standard for cool. Meanwhile, Gucci, founded in the 1920s as a leather-goods firm, and famous among jet-setters in the 1960s, had lost prestige until its reinvention in the 1990s as a source of ultrasexy fashions and accessories. Domenico Dolce and Stefano Gabbana founded Dolce & Gabbana in 1982, and skyrocketed to fame with fashions that recall the sex-bomb stars of 1950s Italian cinema.

Italy's success as a center of modern fashion derives in large part from a uniquely Italian model of the fashion industry, quite different from that in other countries. It is immediately apparent, for example, that the family unit remains an important feature of the Italian fashion system. Craft traditions also remain strong. At the same time, the most up-to-date technology is readily available. While a handful of star designers from Milan and Rome attract public attention, hundreds of anonymous but highly trained creative talents work at family firms and



large companies throughout the country. A skilled workforce is available both for factory employment and in small-scale production by independent contractors. Florence, Rome, and later Milan have all been important fashion centers, but the geography of Italian fashion is widely dispersed, and different regions of Italy specialize in different materials and goods. In addition to the regional segmentation of production in specific geographic areas known as “the Districts,” the Italian fashion system is also characterized by the vertical integration of production from fiber to finished product.

The Italian fashion system in the early 2000s integrates state-of-the-art production of modern apparel, relaxed tailoring, luxury leather goods and knitwear, and research into new modes of design and production together with thread, yarn, and fabric innovations. Italian style is characterized by understated luxury and modernism, as well as glamour and sensuality. Fashion designers in Italy are not considered “artists” so much as skilled workers within an industrial system. One of the dominant characteristics of the Italian fashion industry is its interdisciplinary nature: the seamless blend of product development, new materials and technology, new communications methods, celebrity, tradition, and art.

Since the Biennale di Firenze in 1997, which included a city-wide exhibition that posed the relationship between art and fashion, further opportunities of this kind of convergence have been created; for example, the Fondazione Prada in Milan has an exhibition policy of promoting contemporary art. Nothing could be more representative of a designer’s aesthetic spirit than a flagship store. In 2000, Prada Group hired the eminent architect Rem Koolhaas

to conceive of new and technologically innovative retail spaces for the presentation of products in new and ultra-modern ways. And, as Guy Trebay wrote in the *New York Times*, Carla Sozzani, proprietor of Corso Como 10 in Milan, presents Italian and international luxury brands in a “true theater of commerce.”

Italian fashion has evolved to supply the market with styles based on both the latest technology and traditional craftsmanship. Designers concur that imagination, research and experimentation are the basis for the Italian Look.

*See also* **Armani, Giorgio; Capucci, Roberto; Dolce & Gabbana; Moschino, Franco; Prada; Pucci, Emilio; Valentino; Versace, Gianni and Donatella.**

#### BIBLIOGRAPHY

- Bianchino, Gloria, et al. *Italian Fashion*. Milan: Electa, 1987.
- Gastel, M. *50 anni di moda italiana*. Milan: Vallardi, 1995.
- Giacomoni, Silvia. *The Italian Look Reflected*. Milan: Mazzotta, 1984.
- Malossi, Gino, ed. *Il Motore della moda*. Florence: Monacelli Press, 1998.
- Menkes, Susy. “Are Italian Designer Brands Having an Identity Crisis?” *International Herald Tribune*, 1 March 2000.
- Steele, Valerie. *Fashion: Italian Style*. New Haven, Conn., and London: Yale University Press, 2003.
- Trebay, Guy. “Fashion Diary; A Model and Her Traitorous Stiletto.” *The New York Times*, 5 March 2002.
- White, Nicola. *Reconstructing Italian Fashion: America and the Development of the Italian Fashion Industry*. Oxford: Berg, 2000.

*Valerie Steele and Gillian Carrara*



**JACKET** A jacket is short coat, worn by both men and women. Apart from the suit, the jacket is one of the most important pieces in a man's wardrobe. If cut and styled well, and if made in a fairly neutral color palette, this versatile piece of outerwear is suitable for both formal and leisure activities. A jacket should never be exaggerated in the shoulder or tight-fitting in the body, but cut proportionately to a man's height and width in single- or double-breasted versions, with notched lapels or Nehru collar revers. There are countless styles and shapes of jackets through history, but each fits neatly into formal and semiformal styles.

#### History

In April 1857 the women's magazine *Corriere delle dame* announced the arrival of the jacket (a shortened version of the morning coat with shorter jacket skirts), a style that would go on to become an essential item for both men's and women's wardrobes. The *Adam Magazine* stated in its July 1935 issue "The jacket, a type of coat that is neither tail coat nor redingote, will be the general fashion in a single-breasted version with skirts that do not reach the knee." Adam went on to say how the jacket "barely covers the buttocks and is shaped like a sack."

The jacket seems to have originated during the Middle Ages or early Renaissance as the jerkin, a more fitted version of the older short tunic worn by working-class men. By the early eighteenth century, the jacket became standard working dress for those employed both in agriculture as well as by servants in urban settings.

From the late 1830s, fitted single-breasted lounge jackets (as opposed to more loosely cut jackets of the previous century), with darts beneath the arms, small revers, and waisted pockets became popular with middle-class men, with a double-breasted version appearing about 1862 (which would later become known as the reefer jacket). At that time the single-breasted Norfolk jacket, which buttoned high to the neck, became very fashionable, particularly for country sporting activities.

But by the end of the nineteenth century, only three-buttoned styles were deemed fashionable, with the lounge jacket remaining the most popular. One version, made with silk-fronted lapels, was often worn to dinner parties and would become known simply as a dinner jacket (part of the formal suit known as a "tuxedo").

Similar styles to those worn in the nineteenth century were worn for most of the twentieth century and into the present century as well. Sports jackets are still worn with flannels, the Norfolk remains a sporting favorite, and blazers with brass buttons are popular summer attire when worn with white pants. The upper garment of a man's suit is known as a jacket, and "dinner jacket" remains an alternative term for the ensemble known as "black tie."

#### Jackets in the Early 2000s

The term "jacket" has assumed a much wider meaning. No longer simply associated with more formal styles, "jacket" has become an umbrella term for many styles, including sports jackets, Harringtons, anoraks, blazers, and even bomber jackets. Originally cut in wool, tweed, and cotton, current styles incorporate nylon, leather, suede, and hemp.

See also **Blazer; Coat; Outerwear; Sports Jacket; Windbreaker.**

#### BIBLIOGRAPHY

Amies, Hardy. *A, B, C of Men's Fashion*. London: Cahill and Company Ltd., 1964.

Byrde, Penelope. *The Male Image: Men's Fashion in England 1300–1970*. London: B.T. Batsford, 1979.

Chenoune, Farid. *A History of Men's Fashion*. Paris: Flammarion, 1993.

De Marley, Diana. *Fashion for Men: An Illustrated History*. London: B.T. Batsford, Ltd. 1985.

Keers, Paul. *A Gentleman's Wardrobe*. London: Weidenfeld and Nicolson, 1987.

Roetzel, Bernhard. *Gentleman: A Timeless Fashion*. Cologne, Germany: Konemann, 1999.

Schoeffler, O. E., and William Gale. *Esquire's Encyclopedia of 20th Century Fashions*. New York: McGraw-Hill, 1973.

Wilkins, Christobel. *The Story of Occupational Costume*. Poole, U.K.: Blandford Press, 1982.

Tom Greatrex

**JAMES, CHARLES** Charles Wilson Brega James was born 18 July 1906, in Camberley, Surrey, England. He was described by a friend, Sir Francis Rose, as temperamental,



**Charles James fitting a dress for Mrs. Randolph Hearst.** Known for his obsessive attention to the fit of garments, James created gowns for several prominent socialites during his career. © JERRY COOKE/CORBIS. REPRODUCED BY PERMISSION.

artistic, and blessed even in childhood with the ability to escape the mundane chores of life like a trapeze artist. His mother's family was socially prominent in Chicago and his father was a British military officer, so young Charles experienced an international upbringing. He was educated at Harrow, a British public school, where he met the fellow fashion enthusiast and fashion photographer Cecil Beaton, whose images later defined James's work.

While still in his teens James initiated his design career in Chicago, where friends of his mother supported him. He began by making patterned scarves that he modeled and sold from his office desk at the architectural division of a utilities company, where he was employed. When he was fired from his job, he turned to millinery.

He sculpted hats directly on the heads of clients in the shop he had named after a school friend, Charles Boucheron. In 1928 James left Chicago in a swirl of financial confusion and relocated in New York City. He was there long enough for Diana Vreeland to observe and comment on his hats, to have his hats merchandised through a prominent department store of the time, and to begin designing dresses before heading to London in 1929. For the next ten years he divided his time between London and Paris, with brief promotional journeys to Chicago and New York. During this period he opened his first salon in London, located in Mayfair, but he quickly declared bankruptcy. In 1933 he reopened the business.

James, who was never afraid to try new materials, spiraled a zipper around the torso in 1929, thus designing his famous taxi dress. The taxi dress and several other of his designs were licensed in the early 1930s so that manufacturers in both England and the United States could copy them. Marketed in famous department stores of the day—most notably Best and Company, Marshall Field's, and Fortnum and Mason—these garments gave his designs, if not his name, wide visibility. Friends of James's mother on both sides of the Atlantic were counted among his most enthusiastic clients for his increasing output of couture garments, at least until her death in 1944. Additionally, his designs intrigued actresses such as Gertrude Lawrence and women with artistic leanings such as Anne, countess of Rosse, and Marit Guinness Aschan. By this time, however, the twin nemeses of James's career were obvious: his desire to receive outsized financial rewards for his designs, coupled with perfectionism and his insistence on total control, eventually destroyed him.

The late 1930s were a period of great and lasting creativity for James. He produced the Corsette or L'Sylphide evening dress (1937); the two-pattern piece halter gown (1937); La Sirène evening dress with a pleated front panel (1938); a raised, pouf-fronted gown (1939); and the Figure-8 wrapped skirt (1939). In 1937 James held his first showing in Paris; included among the garments were striking wraps made of old silk ribbons from the firm of Colcombet. For the remainder of his design career, James produced variants of the ribbon gowns he first fashioned for this Paris show. The gowns were initially in two pieces, bodice and skirt, with the winglike skirt featuring tapering tips of ribbon ending in infinity at the waistline; later examples featured one-piece skirts constructed of cut fabric terminating in a much less graceful manner. Indeed, James continually reused many of the designs that he first created in the 1930s. For example, the garment made for Austine Hearst that James himself identified as his thesis in dressmaking, the 1953 Clover Leaf or Abstract gown, actually evolved from a trilobed, skirted gown created in 1938 and a cloverleaf crown hat designed in 1948. Excluding mass-produced designs of the 1930s, for which no records are known to



exist, James created just over one thousand designs during his career. Only a few of James's designs are titled; those that generally identify a unique cut rather than a single garment.

Because of various financial escapades that skirted the limits of legality, James found himself in 1939 no longer welcome in England. The next year he opened Charles James, Incorporated, at 64 East Fifty-seventh Street, New York City. Virtually ignoring wartime rationing, he began designing collections for Elizabeth Arden and redesigning her couture collection in 1944; their relationship was severed in 1945 because of financial overruns. However, the Arden-James partnership spawned a Cecil Beaton drawing of several of James's greatest designs, including a variant of the *Sirène* gown, which is associated with the collaboration.

Following his year-long stint at Arden, James established himself at 699 Madison Avenue, the address where he remained longer than any other in his career. One observer quipped that it was James's perpetual house of torture, not couture. The majority of extant James couture creations came from the Madison Avenue workrooms. James did not let go of his creations easily. He made his clients pay, sometimes twice for the same gown, and sometimes for a garment he had also promised another client. He was notorious for not having garments delivered on time. He was known to cut completed garments off of clients because he was unhappy with either the product or the client. Despite his volatile and often outrageous behavior, his clients acknowledged his genius for cut and color, and many of them supported him financially until the end of his career.

James was obsessed with understanding exactly how clothes worked on the body. He spent thousands of dollars in 1950 and 1951 trying to understand how a sleeve worked. The result was an arced sleeve that drew an editorial observation that James's interest in a sleeve was equivalent to an engineer's interest in a bridge. The writer had it right, for James worked not only with tools associated with dressmaking but also construction tools like calipers, a compass, and a plumb line, among others. During his later years James tried teaching his theories, which related to the proportion of the female figure and how it intersected with apparel construction. In the end, some of his clients found his clothes a joy to wear, while others were tortured. One even bought two opera seat tickets, one for the skirt of her "Butterfly" gown, the other for its sweeping, layered tulle back panel.

So sure was James of the cut of his garments that only rarely does one find him using either patterned fabrics or surface embellishment. Indeed, one of the joys of looking at a James creation is following the flow of seams, seams that seem to go in previously unexplored directions. He made this indulgence easy by selecting contrasting fabrics, such as silk jersey, satin, and taffeta or velvet, organdy, and satin to meld in skirts of black, gar-

net, and tobacco brown or rose red, white, and ruby. He enjoyed blending cool celadon and celery greens, as well as contrasting warm moss and cool bottle greens. When combinations of purple, pink, and green were all the rage in the mid-1940s, James never blended such colors; rather, he would meld dusty rose and pale gold; mustard and maroon; and oranges and blacks in different materials. On a garment's surface he treated the two sides of the fabric equally, playing the color and texture of the one against the other.

For roughly a decade, from 1947 to 1954, James achieved success and recognition. His garments were acquired by many of the fabled socialites of the period, including Mrs. William (Babe) Paley, Mrs. William Randolph (Austine) Hearst Jr., Mrs. Harrison (Mona) Williams, Mrs. Cornelius Vanderbilt Whitney, Mme. Arturo Lopez-Willshaw; by fabled theatrical personalities such as Gypsy Rose Lee and Lily Pons; and by notable collectors of art such as Dominique de Menil. But the most important client of his career was Millicent Huddleston Rogers, a Standard Oil heiress. In her he found a perfect figure to dress, a client with whom he could discuss art and design. Moreover, she was able to pay his inflated prices. She arranged an exhibition of James's work at the Brooklyn Museum in 1948; the show featured the garments he had made for her during the previous ten years. These formed the nucleus of the unequalled collection of Charles James material at this institution, which includes not just garments but half and full toiles and card patterns. Of all James's clients, Rogers is the only one with whom he is known to have codesigned a garment, an eighteenth-century inspired, open-robe gown.

Even while the manager Kate Peil was keeping his dress salon on an even keel, James was becoming restless and demanding more recognition of his talents as well as increased financial reward. To this end he rapidly entered into contractual arrangements with a variety of manufacturers. In 1951 he began by working with the Cavanaugh Form Company, a mannequin manufacturer, to produce his uniquely proportioned, papier-mâché dress form that he called Jenny. In 1952 he began designing collections of dresses and separates for Seventh Avenue's Samuel Winston and suits and coats for William Popper that were retailed by Lord and Taylor. In 1953 James designed furs for Gunther Jaeckel and belts for Bruno Belt based on his "floating line" principle—that is, the waist is not a true oval but has depth as well as dimension. In 1954 he added a line of jewelry to be manufactured by Albert Weiss and agreed to design for another Seventh Avenue concern, Dressmaker Casuals. By the time this last contract was signed, however, previously signed agreements were unraveling due to James's inability to deliver designs on time and his convoluted business practices. Two Coty awards in 1950 and 1954 for "great mystery of color and artistry of draping" and "giving new life to an industry through his sculptural ready-to-wear coats designed for Dressmaker Casuals" did nothing for

the ensuing courtroom battles that effectively ended the most productive and potentially profitable period in James's career.

He tried in 1956 to design a line of Borgana synthetic fur coats with Albrecht Furs as well as a coat for off-the-rack distribution by E. J. Korvette. Most astonishingly, he designed a line of infant wear to be manufactured by Alexis Corporation of Atlanta. James married Nancy Lee Gregory in 1954 and soon had a young family. His success with the baby garments surely lay in the fact that once again he had at his disposal a live model on which to experiment, his son, Charles Junior. As with so many other early designs that evolved over the years, James transformed some of the baby clothes into adult attire.

By 1958 James was a beaten man, unwelcome on Seventh Avenue, and mentally, physically, and financially drained. His marriage ended in 1961, and in 1964 he moved into New York's bohemian hotel, the Chelsea. Here he worked with the illustrator Antonio to document his career. Old clients joined with his protégé Halston in 1969 in a bravely attempted salute to his career. James attempted to document the creations of a lifetime, whether they were in public or private holdings. He accomplished some design work with Elsa Peretti and Elizabeth de Cuevas. Above all, during those final years of his life, Charles James was fanatical about securing his proper place in the history of twentieth-century fashion.

His fellow fashion designers, potentially his most severe critics, left no question regarding their assessment of his talent. Poiret passed his mantle to James, and Schiaparelli and Chanel dressed in his clothes. Dior praised him for being the inspiration for the New Look, and Balenciaga saw James as the greatest and best American couturier; moreover, he believed that James was the only couturier who had raised dressmaking from an applied to a pure art form.

See also **Art and Fashion; Halston; Milliners.**

**BIBLIOGRAPHY**

Coleman, Elizabeth A. *The Genius of Charles James*. New York: Holt, Rinehart and Winston, 1982.  
 Martin, Richard. *Charles James*. London: Thames and Hudson, 1997.

*Elizabeth Ann Coleman*

**JAPANESE FASHION** The appearance of Western clothing and fashion during the Meiji era (1868–1912) represents one of the most remarkable transformations in Japanese history. Since the United States' 1854 treaty allowing commerce, negotiated by Commodore Matthew Perry, the Japanese have enthusiastically and effectively borrowed and adapted styles and practices from Western countries. Until then, Japan had isolated itself economically, politically, and culturally from the West as well as



**Children in traditional Japanese costume.** During the Meiji period, the T-shaped *kosode* became known as the *kimono*, and it is now recognized as the national dress of Japan. The *hakama*, as worn by the young boy, can be worn as an outer garment over the *kimono*. © JOHN DAKERS; EYE UBIQUITOUS/CORBIS. REPRODUCED BY PERMISSION.

neighboring countries for two hundred years. The new Meiji era heralded hope for the future, and government officials felt change necessary for the system to quickly convert Japan into a modern state. Emperor Meiji instituted a parliamentary form of government and introduced modern Western educational and technological practices. The Japanese were then exposed widely to Western influences, and its impact on people's lives has been impressive.

This new modern phenomenon encouraged and expedited the spread of Western clothing among ordinary people, and it became a desirable symbol of modernization. It was first adopted for men's military uniforms, with French- and British-style uniforms designed for the army and navy, as this style was what Westerners wore when they first arrived in Japan. Similarly, starting in 1870, government workers, such as policemen, railroad workers, and postal carriers, were required to wear Western male suits. Even in the court of the emperor, the mandate to dress in Western clothing was passed for men in 1872 and for women in 1886. The emperor and empress, as public role models, took the lead and also adopted Western clothing and hairstyles when attending official events, and

Japanese socialites were also participating in lavish balls in Western-style evening gowns and tuxedos.

By the 1880s, both men and women had more or less adopted Western fashions. By 1890, men were wearing Western suits although it was still not the norm, and Western-style attire for women was still limited to the high nobility and wives of diplomats. Kimonos continued to dominate in the early Meiji period, and men and women combined Japanese kimonos with Western accessories. For instance, for formal occasions, men wore Western-style hats with *haori*, a traditional waistcoat, *bakama*, an outer garment worn over the kimono that is either split like pants between the legs or nonsplit like a skirt.

Conversely, there was also a trend for Japanese goods in the West. The opening of Japan's doors to the West enabled the West to significantly come into contact with Japanese culture for the first time. New trade agreements beginning in the 1850s resulted in an unprecedented flow of travelers and goods between the two cultures. By the

end of the nineteenth century, Japan was everywhere, such as in fashion, interior design, and art, and this trend was called *Japonisme*, a term coined by Philip Burty, a French art critic. Western appreciation for Japanese art and objects quickly intensified, and World Fairs played a major role in the spread of the taste for Japanese things. In an age before the media, these fairs were influential forums for the cultural exchange of ideas: London in 1862, Philadelphia in 1876, and Paris in 1867, 1878, and 1889.

### Fashion after World War II

During the Taisho period (1912–1926), wearing Western clothing continued to be a symbol of sophistication and an expression of modernity. It was in this period that working women such as bus conductors, nurses, and typists started wearing Western clothes in everyday life. By the beginning of the Showa period (1926–1989), men's clothing had become largely Western, and by this time, the business suit was gradually becoming standard apparel for company employees. It took about a century for



**Western-style clothing for sale in Japan.** In the mid-nineteenth century, Japanese dress began to be influenced by the West, and by the late twentieth and early twenty-first centuries, most urban Japanese only wore traditional clothing on special occasions.

© MICHAEL S. YAMASHITA/CORBIS. REPRODUCED BY PERMISSION.



**Table 1: Japanese Designers' Year of First Collection in Paris**

Japanese Designers	First Collection in Paris
Kenzo	1970
Issey Miyake	1973
Kansai Yamamoto*	1974
Yuki Torii	1975
Hanae Mori	1977
Junko Koshino	1977
Yohji Yamamoto	1981
Comme des Garçons by Rei Kawakubo	1981
Junko Shimada	1981
Hiroko Koshino*	1982
Zucca by Akira Onozuka	1988
Mitsuhiro Matsuda*	1990
Trace Koji Tatsuno	1990
Atsuro Tayama	1990
Yoshiki Hishinuma	1992
Masaki Matsushita	1992
Junya Watanabe	1993
Shinichiro Arakawa	1993
Naoki Takizawa**	1994
Koji Nihonmatsu	1995
Miki Miyai	1996
Junji Tsuchiya	1996
Yoichi Nagasawa	1997
Keita Maruyama	1997
Oh!Ya? By Hiroaki Ohya	1997
Gomme by Hiroshige Maki	1997
Hirokichi Nakano	1998
Yuji Yamada	1999
Undercover by Jun Takahashi	2002

\*Hiroko Koshino, Kansai Yamamoto, and Mitsuhiro Matsuda are no longer showing their collections in Paris but continue to design in Japan.

\*\*Takizawa started designing for Issey Miyake's menswear in 1994 and, after Miyake withdrew from his women's wear in 1999, Takizawa took over the collection.

Western clothing to completely infiltrate Japanese culture and for people to adopt it, although women were slower to change.

After World War II, the strong influence from the United States caused Japanese ways of dressing to undergo a major transition, and people began to more readily follow the trends from the West. Japanese women were starting to replace the loose-fitting trousers called *monpe*, required wear for war-related work, with Western-style skirts. By the early 2000s, the kimono had virtually disappeared from everyday life in Japan. Kimonos were worn only by some elderly women, waitresses in certain traditional Japanese restaurants, and those who teach traditional Japanese arts, such as Japanese dance, the tea ceremony, or flower arrangement. Furthermore, special events at which women wear kimonos included *batsumode* (the new year's visit to shrines or temples), *seijinshiki* (ceremonies celebrating young people's reaching the age of twenty), university graduation ceremonies, weddings, and other important celebrations and formal parties.

Fashion information from Europe, such as Christian Dior's New Look, was disseminated by way of the United States. The new trends and fashion were generated pri-

marily from the American and European movies shown to the Japanese public. For instance, when the English film *The Red Shoes* was first screened in Japan in 1950, red shoes became fashionable among young people. Similarly, when the film *Sabrina*, starring Audrey Hepburn, was shown in 1954, young Japanese women became fond of tight-fitted Sabrina pants, and flat low-heel Sabrina sandals became trendy. After the mid-1960s, Japanese men adopted the new "Ivy Style," which paid homage to the fashions of American Ivy League university students. This style supposedly came from the traditional fashions of America's elite class and spread from young students to middle-aged Japanese men.

As Japan's economy prospered in the 1980s, the Japanese fashion and apparel industries expanded rapidly and became very profitable as consumers were becoming fashion-conscious. A new fashion movement called the "DC Burando" was focused on brands of clothing with insignia or with clearly identified styling of specific fashion designers. Famous brands, such as Isao Kaneko, Bigi by Takeo Kikuchi, and Nicole by Hiromitsu Matsuda, among many others, had cult-like followings. Some of the women's fashion trends diffused during this decade were *bodikon* (body-conscious) style, emphasizing the natural lines of the body, and *shibukaji* (Shibuya casual), originating among high school and college students who frequented the boutiques of Tokyo's Shibuya Ward shopping streets.

While Japanese create their own unique trends, they are at the same time voracious followers of Western fashion. They are eager to dress themselves in the latest designs from such names as Chanel, Yves Saint Laurent, Christian Dior, and Gucci. Even in the traditional corporate world, many companies implemented the trend "Casual Friday" that originated in the United States, allowing workers to wear casual clothing on Fridays.

**Japanese Youth Fashion**

In Japanese society of the early twenty-first century, the uncontested arbiters of fashion, street fashion in particular, were high school and junior high school students.



"The widespread popularity of the 'Japanese fashion' in the 1980s was a decisive factor in placing Tokyo on the list of international fashion capitals. A number of Japanese designers ... established the Tokyo Designers' Council in the early 1980s to handle the inflow of foreign editors covering the local collections."

Lise Skov, in "Fashion Trends, Japonisme and Postmodernism."

Among them, loose, baggy white knee socks deliberately pushed down to the ankles like leg warmers were all the rage. Fashion-conscious girls have taken the lead in setting fashion trends. Young Japanese embraced Western fashion in a unique Japanese way. While Japan produced its own distinctive fashion, it drew on a mix of the latest trends from the United States and Europe. They became the new breed of young Japanese who were not afraid to break and challenge the traditional values and norms.

In the early twenty-first century, it became common on the streets of Tokyo to see groups of young girls with long, dyed-brown hair, tanned skin, and miniskirts or short pants that flare out at the bottom. Their natural black hair was often replaced with hues of bleached-blond and red. It became fashionable to have a light suntan with heavy makeup. Many of them wore thick-soled mules in the summer and white boots with towering platform soles in winter. As in the West, tattoos were also part of the latest fashion. Previously, tattoos held a connection to the Yakuza, the Japanese mafia, who adorned themselves with elaborate tattoos as a badge of membership.

As Japan faced the worst economic recession in history, the younger generation's value system had become changed—the result of a deliberate move away from traditional ideology and ways of life. The previous generation's Japanese values, such as selfless devotion to their employers, respect for seniors, and perseverance, were breaking down. The decline of traditional way of thinking had accelerated in the teenage generation. Attending cram schools after their regular school hours was no longer the norm. The Japanese shifted from deeply disciplined, industrial attitudes to much freer consumerist ways. The doctrine of long study hours and single-minded focus on exams and careers that helped build Japan were disappearing and evaporating. The Japanese youth post-World War II became more hedonistic and wanted to have fun and live moment to moment, and their attitude was reflected in their norm-breaking fashion and styles.

### Designers and Their Influence

As Japanese began to consume Western fashion, Japanese designers were becoming prominent in the West, especially in Paris. They are said to have created the Japanese fashion phenomenon and influenced many Western designers. Kenzo in 1970, Issey Miyake in 1973, Hanae Mori in 1977, Rei Kawakubo of Comme des Garçons and Yohji Yamamoto in 1981, first appeared in the Western fashion world and have since solidified their positions. Fashion professionals recognize and accept their achievements because of their “Japaneseness” reflected on their designs, and many called it “the Japanese fashion” only because these clothes were definitely not Western in regard to constructions, silhouettes, shapes, prints, and combination of fabrics. The Japanese public is reminded of its racial and ethnic heritage every



“When I first began working in Japan, I had to confront the Japanese people's excessive worship of things foreign and fixed idea of what clothes ought to be. I began ... to change the rigid formula for clothing that the Japanese followed.”

Issey Miyake, quoted in *Issey Miyake: Bodyworks*.

fashion season with the references to Japanese cultural products and artifacts. Fashion journalists and critics in the West used everyday Japanese vocabulary familiar to Westerners to describe their designs. The source of their design inspiration undoubtedly came from symbols of Japanese culture, such as Kabuki, Mount Fuji, the geisha, and cherry blossoms, but their uniqueness lies in the ways they deconstructed existing rules of clothing and reconstructed their own interpretation of what fashion is and what fashion can be. These Japanese first proved to Paris, and then to the world, that they were masters of fashion design, prompting Western societies to reassess the concept of clothing and fashion and also the universalism of beauty. They shocked fashion professionals in the West by showing something none of them had seen before.

The Japanese designers were the key players in the redefinition of clothing and fashion, and some even destroyed the Western definition of the clothing system. Rather than being isolated as deviant and left outside the French fashion establishment, they were labeled as creative and innovative and were given the status and privilege that, until then, only Western designers have acquired. These Japanese managed to stay within the territory that is under the authorization of the system and the fashion gatekeepers.

After the first generation Japanese designers, other Japanese were flocking to Paris one after another. The second, the third, and the fourth generations were emerging in Paris. There were formal and informal connections among almost all the Japanese designers in Paris, some through school networks and others through professional networks. They can be traced back directly or indirectly to Kenzo, Miyake, Yamamoto, Kawakubo, and Mori as they have learned the mechanism of the fashion system in France.

These Japanese acquired the means to enter the French fashion system and at the same time used their ethnic affinity as a strategy. They achieved insider status in the realms where artistic power is concentrated and where gatekeepers, such as editors and critics, participate. The line between inside and outside the system is an issue about status and legitimacy, and the inside bound-

**Figure 1. Network Map of Japanese Designers in Paris: 1998–99**

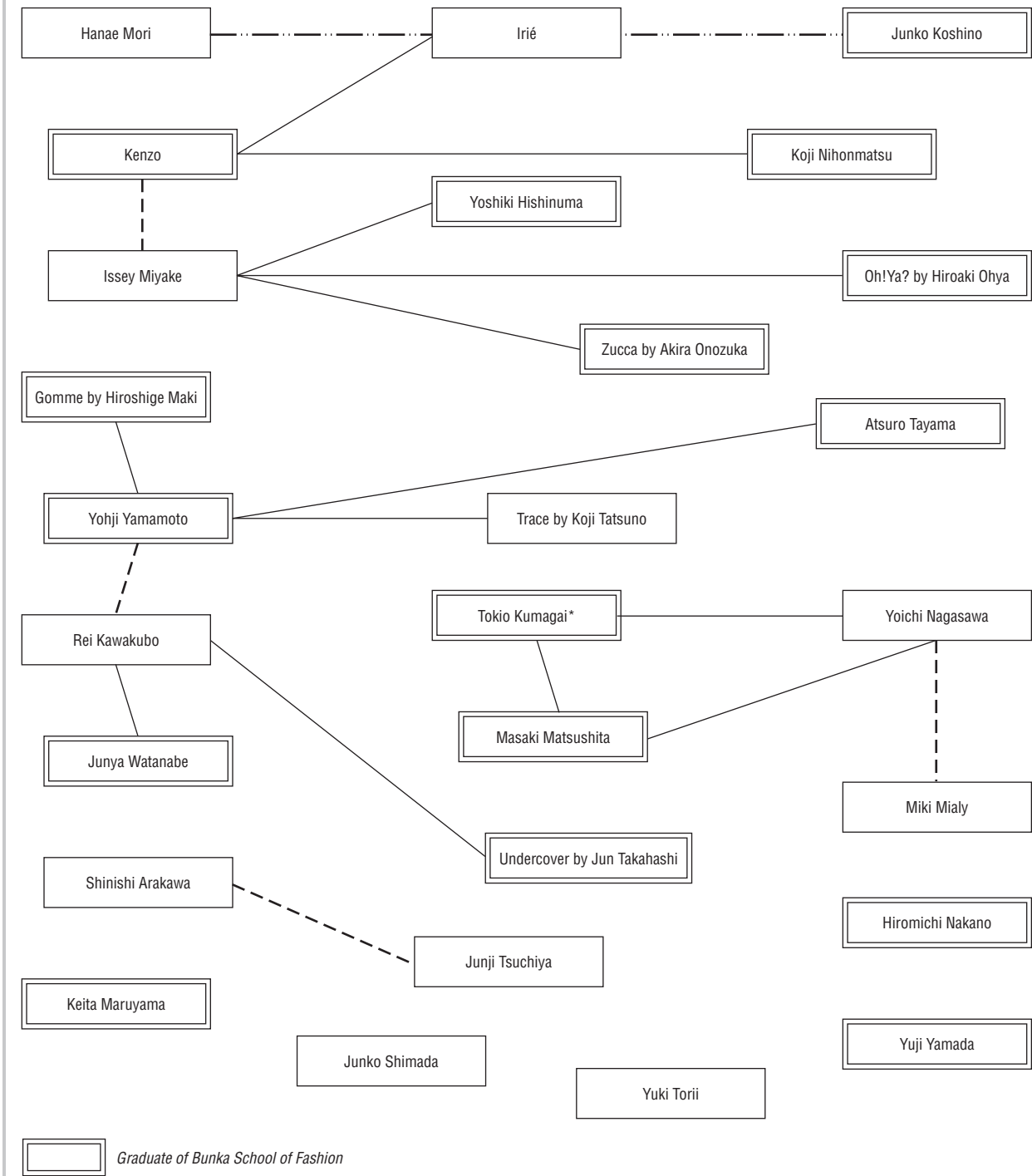

\* Tokio Kumagai set up his company in Paris in 1980 and died in 1987.

SOURCE: Compiled from *Modem* (1998, 1999) and various other documents.



aries provide privilege and status whose boundaries in the world of fashion can be expanded and manipulated through style experiments and innovation. Fashion professionals accept and welcome designers who push and test the boundaries, signs of creativity. Once the designers are acknowledged as insiders, although recognition is never permanent, they slowly gain worldwide attention. Fashion design is an occupation where prestige necessarily antedates financial success. Prestige, image, and name bring financial resources. Until designers reach that stage, they struggle to achieve it; once it is achieved, they struggle to maintain it.

Due to the structural weaknesses of the fashion system in Japan, Japanese designers have continued to mobilize in Paris, permanently or temporarily, to take part during the Paris Collection. Though Kenzo's appearance in Paris in 1970 through Yamamoto's and Kawakubo's in 1981 had some impact, in the early 2000s Tokyo still fell far behind Paris in the production of "fashion"—that is, setting the fashion trends, creating designers' reputation, and spreading their names worldwide. Tokyo as a fashion city lacked the kind of structural strength and effectiveness that the French system had. Thus, lack of institutionalization and of the centralized fashion establishment in Japan forced designers to come to Paris, the battlefield for designers, where only the most ambitious can compete and survive.

Acceptance of the new Japanese styles led to the success of a group of Belgian designers, who also utilized the French fashion system to their advantage. From the mid-1980s to the early 1990s, a group of radical Belgian designers trained at the Royal Academy of Fine Arts in Antwerp followed the path that the Japanese had taken: Dirk Bikkembergs in 1986, Martin Margiela in 1988, Dries Van Noten in 1991, and Ann Demeulemeester in 1992, among others. By tracing the success of new designers, such as the Japanese and the Belgians, in Paris, one can see whether they are promoting and reinforcing the existence of the French fashion authority and the system, or are impeding the stability of the system and proposing the emergence of a new institutional system.

### Influence in Western Fashion

Exhibitions such as *Orientalism* at the Costume Institute of the Metropolitan Museum in 1994, *Japonisme et Mode* at the Palais Galliera costume museum in 1996, *Touche d'Exotisme* at the Art Museum of Fashion and Textile in Paris in 1998, and *Japonisme* at the Brooklyn Museum of Art in 1998, show that Western designers have long been inspired by the Eastern textiles, designs, construction, and utility, including Japanese kimonos. For instance, Jeanne Lanvin's dress with its bolero jacket in the 1930s simulated kimono sleeves. Similarly, in the beginning of the twentieth century, as boning and corsetry were reduced to a minimum, a loose fitting kimono sleeve of Paul Poiret came in, and the high-neck collar was abandoned for an open V-neck resembling a kimono. Chrysanthemum

prints or the exotic fabrics were used by many couturiers, such as Charles Worth and Coco Chanel. Those fascinated by the kimono's geometry, such as Madeleine Vionnet, cut dresses in flat panels and decorated only with wave-seaming, a Japanese hand-stitching technique. The East remained a fashion influence through World War I. Western designers incorporated Japanese elements into Western clothing with Western interpretation while remaining within the normative definitions of clothing and fashion.

See also **Japanese Traditional Dress and Adornment; Kimono; Miyake, Issey; Mori, Hanae; Yamamoto, Yohji.**

### BIBLIOGRAPHY

- Dalby, Liza. *Kimono: Fashioning Culture*. New Haven, Conn.: Yale University Press, 1993.
- Kawamura Yuniya. *The Japanese Revolution in Paris Fashion*. Oxford: Berg Publishers, 2004.
- Kenzo. Tokyo: Bunka Publishing, 1995.
- Mendes, Valerie, and Amy de la Haye. *20th Century Fashion*. London: Thames and Hudson, 1999.
- Modem. Collections femme printemps-été, 1999 (Women's Spring-Summer Collection, 1999), 1998.
- . Collections femme automne-hiver 1999–2000 (Women's Fall-Winter Collection, 1999–2000), 1999.
- Mori Hanae. *Hanae Mori Style*. Tokyo: Kodansha International, 2001.
- Skov, Lise. "Fashion Trends, Japonisme and Postmodernism." *Theory, Culture and Society* 13, no. 3 (August 1996): 129–151.
- Steele, Valerie. *Women of Fashion: Twentieth-Century Designers*. New York: Rizzoli International, 1991.
- Sudjic, Deyan. *Rei Kawakubo and Comme des Garçons*. New York: Rizzoli International, 1990.
- Tsurumoto Shozo, ed. *Issey Miyake: Bodyworks*. Tokyo: Shogakkan Publishing Co., 1983.
- Wichmann, Siegfried. *Japonisme: The Japanese Influence on Western Art since 1858*. London: Thames and Hudson, Inc., 1981.

Yuniya Kawamura

### JAPANESE TRADITIONAL DRESS AND ADORNMENT

Japan, an archipelago consisting of four principal islands situated off the east coast of the Asian mainland, was a relative latecomer in terms of both receiving from the outside and nurturing at home a rich and sophisticated material culture. Whereas ample archaeological evidence exists in China of extant garments, ceramic sculptures, and tomb paintings, giving a credible view of Chinese costume history across several centuries before the advent of the Common Era, a verifiable history of Japanese dress does not begin until the eighth century C.E.

### Speculative Early History

Apart from its indigenous peoples, Japan was populated by successive waves of immigrants from China, Korea,



**Woman modeling Japanese formal court ensemble.** While it varied from period to period, female imperial court dress often featured voluminous sleeves, overlapping panels, and many layers of fabric. © REUTERS/CORBIS. REPRODUCED BY PERMISSION.

Southeast Asia, Central and North Asia, and possibly Polynesia. Native textile fibers were processed from the inner bark of trees and plants, and weaving was done on a backstrap loom. Textile technology continually advanced as the result of immigration, with the production of silk presumably established by the third century. Silk remains the fiber of choice for traditional Japanese dress.

The archaeological record in Japan yields little in the way of human imagery until the fifth century C.E. Prior to that time representations of stick figures found on pottery shards and bronze bells allow for the hypothesis that a long tunic-like garment, belted at the waist, may have been a common form of dress.

In the fifth and sixth centuries, large quantities of *haniwa*, terra-cotta tomb sculptures, were produced for important burials. Male figures are often depicted wearing tight, body-hugging, long-waisted jackets flared at the sides with long tubular sleeves and baggy pants secured with ties just above the knees. Such garb is reminiscent of the practical wear of horse-riding, nomadic steppe peoples from the Asian mainland. The horsemen required

full mobility of arms and legs to guide their mounts and tightly fit garments for warmth in the cold, wind-swept northern latitudes. Loose-fitting, wide-sleeved, floor-length Chinese robes, the other dominant elite mode of dress on the continent, were the antithesis of this kind of nomadic clothing.

Typical female *haniwa* figures wear an upper garment resembling the men's jacket and a skirt, rather than trousers. It is important to note that *haniwa* jackets tend to be fastened in a sequence that places the right front panel over the left panel, after which the ties are secured at the right side of the jacket. This was considered a barbaric practice by the Chinese, whose robes were closed left side over right. Japanese dress was to mimic the Chinese mode in this and in other ways soon thereafter.

It is doubtful that *haniwa* dress was widespread in Japan during the fifth and sixth centuries. Such dress would not be suitable for Japan's long months of warm and humid weather, and a life on horseback would have been unlikely in mountainous Japan. Judging from the large number of extant *haniwa* horse figures, a horse-riding elite may well have established itself in Japan during this period, perhaps after an incursion from the Asian mainland, but their way of dressing was not to prevail.

#### Asuka and Nara Periods

The year 552 is considered the official date for the introduction of Buddhism in Japan and marked the first year of the Asuka period (552–710). Buddhism had its origins more than a thousand years earlier in India, spread to China by the beginning of the Common Era, and finally reached Japan by way of Korea. One of the important cultural advances that arrived with Buddhism was literacy. The Japanese employed the Chinese writing system based on ideograms.

Japan's native religion, Shintoism, coexisted with Buddhism, in keeping with a continuous theme in Japanese history of borrowing from the outside while preserving the most valued native traditions and ultimately transforming foreign ways into something uniquely Japanese.

The history of Buddhist dress in Japan, as embodied in the religion's principal ritual garment, a patchwork mantle (*kesa*), illustrates the theme of importation and adaptation. *Kesa* are among the oldest extant garments in Japan. As the physical manifestation of Buddhist teachings, examples were brought from the Asian mainland in order to aid in the implantation of the religion on Japanese soil. In later times, certain *kesa* tested the limits of the garment's parameters in a uniquely Japanese way.

Another early group of costumes in Japan were used during performances and ceremonies commemorating an enormous bronze Buddha completed in 752, midway through the Nara period (710–794). Dignitaries from various Asian countries came to Nara, then the capital of Japan, to attend. These costumes, along with most of the

early *kesa*, have been preserved in the famous temple storehouse known as the Shōsōin.

The Shōsōin performance wear is mostly left-closing and includes both knee-length sleeveless vests and long-sleeved full-length robes. Collars are either narrow and round or V-neck, with front panels that either abut or overlap. Both figural and geometric decorations, in either woven or dyed patterns, are part of the rich legacy of this diverse group of silk robes. Also included are trousers and accessories such as leggings, socks, shoes, and aprons.

Other costumes in the Shōsōin include robes worn by craftsmen, similar in cut to the full-length robes with the round collars mentioned above, but in hemp rather than silk; robes with wide flaring sleeves; and even archaic, right-closing *haniwa*-style costumes.

The Shōsōin costumes are very likely representative of diverse types of Asian dress then in use, and any number of them may well have been made outside of Japan. In later Japanese traditional dress, several of these early modes of clothing were to be reflected in the costumes of the No theater.

According to period documents, dress at Japan's imperial court followed that of China's at this time, with rank indicated by color. Contemporary pictorial representations depict both male and female courtiers in long flowing robes with voluminous sleeves ample enough in length to cover the hands. A characteristic of male dress was a close-fitting, narrow, round collar, while female dress featured wide front panels that overlapped in the left-over-right sequence. Women's court dress also included one or more underrobes that closed in the same manner.

### Heian Period

Kyoto became the new imperial capital at the end of the eighth century, marking the beginning of the long and relatively peaceful Heian era (794–1185). Japan's previous periods of intensive cultural absorption from the Asian mainland was followed by the internal development and refinement of foreign ways combined with native sensibilities.

A costume history of this period cannot be based on extant garments, as extremely few examples have survived. Knowledge of Heian dress is largely derived from pictorial representations, wardrobe records, and two of the earliest novels in world literature—the *Tale of Genji*, by Lady Murasaki Shikibu, and the *Pillow Book* by Sei Shōnagon.

The novels describe the insular world of the imperial court and its daily life full of intrigue, poetry, wit, romance, and a remarkably refined way of dressing. Women wore layer upon layer of silk robes, with only the edges of individual robes being revealed at the sleeve ends, collar, and hem, and the outermost robe setting the overall tone for the color scheme. A woman's taste and sensitivity was displayed by her choice of color combinations in

selecting the various robes for the ensemble in accordance with the season, an occasion, or a prevailing mood. Further articles of clothing, such as a jacket, skirt-like pants (*bakama*), and an apron worn at the back completed women's court dress.

The robe, presumably worn closest to the body in this ensemble, is considered the precursor to the Edo period (1603–1868) *kosode* in terms of construction and shape. This innermost garment had an overall T-shape composed of square- or rectangular-shaped sleeves with narrow openings for the hands. These sleeves attached to long, straight lengths of cloth composing the body of the robe. A relatively wide, flat collar and lapels were sewn to the inner edges of the body panels at the front of the garment. This article of clothing conforms to the present-day kimono.

Male dress of the Heian period retained the narrow, round tunic-like collar reflecting the earlier period of influence from the Asian mainland, and men also wore a skirt-like trouser and an underrobe or two. Sleeve shape departed from previous mainland models in that a square or rectangular shape came to dominate, and a single sleeve could be as wide as the entire body of a garment. In the wearing of such a robe, the bottoms of the sleeves, which were unsewn at their extremities, could practically sweep the ground.

It is also during this period that family crests are thought to have first appeared on clothing. Some Heian costume types have persisted to the present day as seen in imperial court wear, religious dress, and costumes of the No theater.

### Kamakura Period

During the latter part of the twelfth century, the base of power in Japan shifted away from the increasingly decadent, self-absorbed imperial court in Kyoto to provincial military clans who chose the town of Kamakura as their headquarters. There are few extant garments from the Kamakura era (1185–1333), and the period literature is not very rich on the subject of costume. However, well-detailed surviving paintings do give an idea of dress at that time.

Women's clothing was less encumbered by exaggerated multilayering, and large-scale dyed patterns appear on some female outer robes. Pattern-dyed designs were to become one of the most important creative expressions in later Japanese dress. Expressions of originality in men's clothing also began to be manifest through the use of outscaled motifs and the splicing together of pieces from two completely different robes in order to create a startling new costume. Buddhist sects (such as Zen), previously unknown in Japan, were introduced from the Asian mainland, which resulted in the importation of *kesa* made from certain luxurious types of textiles otherwise unavailable to the Japanese. Earlier *kesa* were, on the whole, more humble in appearance.



**Nambokuchō, Muromachi, and Momoyama Periods**

The imperial city of Kyoto became the capital again with the advent of the Nambokuchō era (1333–1392), a period marked by clashes between rival military clans. Warfare continued during the subsequent Muromachi period (1392–1568). Since the advent of the Kamakura era, the imperial family had ruled in name only; the shogun, as the supreme military power, wielded the real power.

In regard to cultural matters, the imperial court ceased to be in the vanguard. Elite members of the military class and high-ranking Buddhist monks were the leading practitioners of the newly established and extremely aesthetic tea ceremony. The shogun Ashikaga Yoshimitsu (1358–1408) was the first important patron of the No theater.

Costumes of the No theater continued to exist in a wide variety of different types through the early twenty-first century. During the initial centuries of the all-male theatrical form, actors wore garments donated from the wardrobes of their elite patrons. By the Edo period (1603–1868), No costumes were being made specifically for use on the stage; however, for the most part the costume styles did not change and continued to reflect the clothing of earlier periods.

Within the broad category of No robes called *ōsode*, a term referring to tall and wide sleeves that are left unsewn at their ends, are certain types of robes long since obsolete in Japan, except within the most conservative and traditional spheres of Japanese life, such as imperial court rites and Shinto rituals.

Often making use of gold threads in the form of flat, gilded narrow strips of paper, along with silk threads, *ōsode* costumes always have woven designs. These designs can be quite bold in scale and composition, though their coloration is more reserved, usually limited to just one color for the silk. The No theater also preserves the skirt-like trousers (*bakama*) of earlier times, and the layered wearing of costumes, with an *ōsode* robe typically worn as an outer robe.

The other principal category of No costumes features robes with sleeves shorter in height and width relative to *ōsode* sleeves. The sleeves are also rounded off at their bottommost outer edges rather than having a right angle as in *ōsode*. Sleeve ends are sewn up, allowing just enough of an opening for the hands to pass through. The name for this general category of No costumes is *kosode*. The same term had been used for the plain silk robe worn next to the skin and under layers of voluminous garments in the Heian period.

During the Muromachi period, the *kosode* literally emerged as acceptable outerwear. What had previously been private intimate wear was now permissible outside of domestic interiors. This form of dress became the principal vehicle for the expression of changing fashions and styles.

During the Edo period, most *kosode*-category costumes still preserved Muromachi and Momoyama period styles. Archaic styles that persisted included the use of heavy, ornate brocade fabric, extensive gilding, the splicing together of two completely different kinds of fabric in one robe, and an empty-center composition that concentrates the design motifs at the shoulders and hem of the robe. Such costumes did, however, change their overall sleeve shape from oblong to squarish in response to an Edo period trend, and certain No robes with embroidered designs were occasionally influenced by contemporary fashion styles.

Extant No costumes date as far back as the latter part of the Muromachi period. No robes were still being made in the early twenty-first century, and some of the modern producers made use of traditional hand weaving and natural dyeing techniques.

For the purpose of providing comic relief from the tragedy and melancholy of No, *kyōgen* plays were traditionally performed along with No plays. Costumes for *kyōgen* reflect lower-class dress and are made of bast fibers (usually hemp or ramie) rather than silk, use no gold threads or gilding, and are patterned by means of dyeing—unlike No robes with their woven, embroidered, or gilded designs. Extant *kyōgen* costumes do not predate the Edo period.

In the 1540s, when the first Europeans reached Japan, the country was in the midst of protracted civil war. This combination of turbulent times and a new wave of foreign influence led to the creation of some astonishing examples of samurai-class dress. Western-style tailoring and the newly imported “exotic” fabrics of European woolen cloth, Indian cotton chintz, and even Persian silk tapestry can be seen in several extant *jimbaori* (a type of vest worn over armor).

Further creativity in male dress is evident in some short *kosode*-shaped garments (*dōfuku*) associated with the leading military figures of the sixteenth century. These robes exhibit unconventional motifs and surprising color combinations.

**Edo Period**

Three successive military leaders were to emerge as unifiers of war-torn Japan. An enduring peace was finally established by the last of the three, Ieyasu Tokugawa. A new capital was established in Edo (later known as Tokyo), and all of the subsequent shoguns were supplied by the Tokugawa clan ruling from Edo while the imperial court remained in Kyoto. Japan entered a period of isolation, during which time the new religion of Christianity was suppressed, travel to and from Japan was prohibited, and foreign trade came under strict controls.

Conservative dress became the norm for the samurai class. Men’s formal wear consisted of a short vest with winglike shoulders and the traditional *bakama*, with both



**Man in samurai clothing.** The traditional samurai costume consists of armor, *hakama* (skirt-like pants), and a short vest worn over the armor. The *hakama* and vest, both typically dyed blue, were made from a bast fiber. © HISTORICAL PICTURE ARCHIVE/CORBIS. REPRODUCED BY PERMISSION.

garments made from a bast fiber patterned with tiny repeat motifs and invariably dyed blue. The samurai had no more wars to fight, though armor and its associated vest continued to be made. Although creative examples of the vest were still produced, samurai were not encouraged to dress like dandies.

The greatest creativity in dress during the Edo period was manifest in the *kosode*. Much of the impetus for transforming this garment into such a fashion-conscious form of dress came from the newly rich merchant class, which was, nevertheless, at the bottom of the social hierarchy.

Whereas the No theater was the preserve of the upper classes, Kabuki theater was the performance art for the nouveau-riche merchants. Most Kabuki costumes have the standard T-shape of *kosode*; however, their coloration tends toward the garish and their design motifs can be overwhelming in scale. For example, a giant lobster might cover the entire back of a robe.

Leading Kabuki actors (also an all-male theatrical form) became wildly popular, their faces and dress disseminated in myriad woodblock prints. However, their costumes tended to be too outlandish to influence fashion, other than by popularizing a particular shade of a color or a certain motif. Kabuki costumes of the early twentieth century continued to resemble those of the Edo period.

Buddhist clergy ranked high on the social scale and were given administrative powers and official support under the Tokugawa government, enabling them to share in the general prosperity. The most unusual tendency seen in *kesa*, the patchwork garment, was a pictorial impulse that resulted in examples being woven, embroidered, or painted with such narrative representational imagery as birds and animals in landscape settings, gatherings of divinities, and even flower arrangements. Two of the methods used to satisfy token adherence to the patchwork tradition involved the stitching of cording or the drawing of lines onto the garment in order to create the impression of a pieced construction. As the *kesa* is a flat, wide, horizontal-oriented, usually rectangular-shaped garment, an inspiration for this new style in surface design was quite likely to have been the broad painted screens widely in use during the Edo period.

The *kesa* also reflected fashionable taste in a more indirect way as a result of the custom for lay Buddhists to donate valuable clothing to temples. The garments would be unstitched, cut up, and remade into Buddhist robes. Other *kesa* were assembled from rich brocades, which were being woven domestically, as the Japanese textile industry had, by this time, absorbed the foreign skills and technology necessary for the weaving of luxury textiles.

The extravagant tendencies in *kesa* led at least one Buddhist sect to make an austere, monochromatic, unpatterned vestment in a bast fiber. Although there were

no new innovative styles, *kesa*—in the early 2000s—reflected all of the variety seen in the Edo-period examples. However, several early twenty-first-century textile artists in the West have made creative works inspired by the traditional form of the *kesa*.

### Meiji Period

Japan was forced to end its isolation in the 1850s when Western powers with advanced military technology demanded trading concessions. The Tokugawa Shogunate collapsed, and power shifted to the imperial family, which moved the court to Tokyo in 1868 and proclaimed a new era, the Meiji (1868–1912). Once again, the Japanese realized the need to keep pace with more developed nations, and embarked upon a policy of rapid Westernization.

Western dress was adopted, with the emperor and empress helping to set an example for the rest of the country by occasionally wearing Western clothing. Buddhists and elite samurai families sold off quantities of *kesa* and No costumes, ultimately enriching museum and private collections in Japan and the West. For the more sophisticated urban population, and especially men, traditional Japanese dress ceased to be a part of everyday wear until eventually the use of traditional dress was relegated to Buddhist temples and monasteries; Shinto shrines; No, *kyôgen*, and Kabuki theater; tea ceremony and other traditional arts such as flower arranging; and the imperial court. Geisha, still an institution in Japan at the start of the twenty-first century, were still expected to entertain in kimono.

In the early 2000s, rites of passage such as children's coming-of-age ceremonies, school graduations, and weddings are occasions for members of the general public to wear traditional dress. A Japanese family also might don kimono when participating in special national and regional festivals or when relaxing after bath time at a traditional inn. It was not uncommon for a Japanese housewife to attend kimono school in order to better understand how to select and properly wear a kimono and its most important accessory, the obi.

During the Meiji period, terms were coined in order to distinguish the old Japanese way of dressing (*wafuku*) from the newly adopted Western dress (*yofuku*). Kimono (derived from the verb for wearing clothes and the word for “thing”) became the new term for the T-shaped garment formerly known as the *kosode*. The word has entered the dictionaries of languages the world over and commonly serves as the designation for the national dress of Japan, just as “sari” is universally recognized as the timeless Indian garment.

During the early Taishō (1912–1926) and late Taishō (1926–1989) periods, the *mingei* movement was founded by artists and intellectuals for the purpose of preserving and perpetuating the folk crafts of Japan, especially as practiced by farmers and ethnic minorities. Those who



championed the idea of *mingei* can be thought of as the East Asian inheritors of the Arts and Crafts movement, although they did not have to insist on the importance of handicraft, as did their Western predecessors, because in the traditional Japanese distinctions between fine and decorative arts were not emphatic. However, the elevation of handcrafted works made by simple-living country people and minorities on the fringe of Japanese society did not fit with conventional ideas of social hierarchy in Japan.

Examples of costumes collected and studied by *mingei* enthusiasts include the bast fiber and cotton robes of the indigenous Ainu tribe, specially dyed costumes from Okinawa, heavily stitched farmers' jackets, and fishermen and firemen's garb.

See also **Kimono; Japanese Fashion.**

#### BIBLIOGRAPHY

- Bethe, Monica, and Iwao Nagasaki. *Patterns and Poetry: Nô Robes from the Lucy Truman Aldrich Collection at the Museum of Art, Rhode Island School of Design*. Providence: Rhode Island School of Design, 1992.
- Bethe, Monica, and Sharon Sadako Takeda. *Miracles and Mischiefs: Nob and Kyôgen Theater in Japan*. Los Angeles: Los Angeles County Museum of Art, 2002.
- Dalby, Liza Crihfield. *Kimono: Fashioning Culture*. New Haven, Conn.: Yale University Press, 1993.
- Dusenbury, Mary. "Textiles." In *Kodansha Encyclopedia of Japan*. Vol. 8. Tokyo: Kodansha International, 1983, 16–20.
- Kennedy, Alan. *Japanese Costume: History and Tradition*. Paris: Editions Adam Biro, 1990.
- Kirihata, Ken. *Nob Costumes*. Kyoto: Kyoto Shoin, 1993.
- Liddell, Jill. *The Story of the Kimono*. New York: E. P. Dutton, 1989.
- Matsumoto Kaneo, ed. *The Treasures of the Shôsôin: Musical Instruments, Dance Articles, Game Sets*. Kyoto: Shikosha, 1991.
- Minnich, Helen Benton. *Japanese Costume and the Makers of Its Elegant Tradition*. Tokyo: Charles E. Tuttle, 1963.
- Noma Seiroku. *Japanese Costume and Textile Arts*. New York and Tokyo: Weatherhill/Heibonsha, 1974.
- Yamanobe Tomoyuki. *Textiles*. Rutland, Vt., and Tokyo: Charles E. Tuttle, 1957.

Alan Kennedy

**JAPONISME** Prior to the 1800s, Japan was a nation isolated from the West. The arrival of its wares in Europe and America in the second half of the nineteenth century precipitated a new creative surge in art and design that became known as *Japonisme*. While many scholars have studied the influence of Japonisme, or the assimilation of Japanese aesthetic principles on European painting and decorative arts, few have addressed its influence on Western dress. And yet fashion, which differs from traditional dress in that it stresses urbanity and constant change, eagerly absorbed the principles of Japanese design.

In the mid-nineteenth century, European and American garments were ornamented with Japanese motifs or made of fabrics exported from Japan while conforming to fashionable Western silhouettes. Later, in the early twentieth century, some costume items, ranging from tea gowns to opera coats, were constructed with elements adapted from the construction of kimonos. More recently, some of the world's most influential designers have emerged from Japan to redefine contemporary fashion.

Although some Japanese objects had been arriving in Europe since the 1600s, it was not until after the American commodore Matthew Perry opened this island nation to international trade in 1854 that Japonisme began in earnest. Its popularity accelerated when many Europeans and Americans saw Japanese artworks and design objects for the first time at the world's fairs of 1862 in London, 1867 in Paris, and 1876 in Philadelphia. These expositions exerted a profound influence on innumerable nineteenth-century artists, artisans, designers, and manufacturers. Everything from paintings to porcelain began to be produced in the Japanese manner. In the 1870s and 1880s, such designs—then considered *avant-garde*—developed into a distinctive style that came to be associated with the aesthetic movement.

While nineteenth-century critics had reservations about artists' adopting Japanese conventions in paintings and prints, this was not true in the arena of fashion. French textile designers in the 1890s, for example, readily appropriated new and "exotic" floral motifs from Japan, and these fabrics were readily used by couturiers like Charles Frederick Worth. The most popular item of dress exported to the West in the late nineteenth century was a modified version of the kimono, worn as a dressing gown. Both fully finished garments and unsewn components were sold at small boutiques and at large firms such as Liberty of London. Kimonos for export were often constructed with elements to suit the European market; these might include a set-in box pleat to accommodate the bustle; a collar lining instead of an under kimono; the addition of a knotted and tasseled trim; and a variety of sleeve styles.

In the decade prior to World War I, the construction of women's garments began to change dramatically. As early as 1908, revolutionary couturiers, such as Marie Callot Gerber and Paul Poiret, took inspiration from the drapery-like quality of kimonos. Loosely cut sleeves and crossed bodices were incorporated into evening dresses, while opera coats swathed the body like bat-winged cocoons.

One of the twentieth century's greatest couturiers, Madeleine Vionnet was inspired by the kimono, with its reliance on uncut lengths of fabric, and raised dressmaking to an art form. From the onset of World War I to the late 1920s, she abandoned the traditional practice of tailoring body-fitted fashions from numerous, complex pattern pieces, and minimized the cutting of fabric. A

“minimalist” with strict aesthetic principles who rarely employed patterned fabrics or embroidery, Vionnet relied instead on surface ornamentation through manipulation of the fabric itself. For example, the wavy parallel folds of a pin-tucked crepe dress evoked the abstracted image of a raked Zen rock garden, itself a metaphor for the waves of the sea.

Although the influence of the kimono on the construction of garments was extremely important in the 1910s and 1920s, surface ornamentation remained a vital force. During the art moderne, or art deco, era, French textiles in the Japanese style developed a more sophisticated use of both abstract motifs and recognizable images. Examples range from metallic lamé dresses that replicate the appearance of black lacquer inlaid with gold particles, to garments of brocaded silk woven with a pattern of crashing waves and fish scales. Also appropriated was the *mon*, or family crest. While the *mon* is usually an abstracted image drawn from nature, such as a bird or flower, it can also represent a man-made object, such as the *nara bi-ya*, or parallel rows of arrows; or celestial bodies such as the *mitsuboshi*, an abstraction symbolizing the three stars of Orion’s belt.

The influence of “exotic” cultures on fashion began to diminish in the late 1930s. Instead, American and European designers created modern versions of historical Western dress, and this trend dominated fashion from the late 1930s through the 1950s. The revival of historical styles offered an escape from the pressures of the Great Depression of the 1930s and helped assert the growing sense of nationalism in Europe at that time. Also a factor in the United States was strong anti-Japanese sentiment during and after the war. Nonetheless, some of this country’s most innovative designers remained open to Japanese influence. One of the best was Elizabeth Hawes, who designed a variety of Asian-inspired garments in the late 1930s and early 1940s using modern Japanese kimono fabric.

The use of Japanese elements became the cornerstone for another revolutionary American ready-to-wear designer, Bonnie Cashin. Born in California in 1915, Cashin was one of a handful of female American designers who made clothes for the modern and active woman. By using the loose construction of the *nakajuban*, or informal kimono worn by peasants, and discarding Western tailoring, Cashin created functional fashions that fit a broad range of sizes and later seemed decades ahead of their time. Not only were her garments in sharp contrast to the couture creations of her French contemporaries, they had little in common with the designs of her American counterparts. Cashin’s use of indigenous Japanese textiles, like double *ikat* silks with their subtle geometric designs, did much to advance the notion of modern luxury in American fashion.

Although by 2004 Japonisme was no longer a major force in fashion, the influence of Japanese design and aesthetics continued to be important. One of the main

reasons was the dramatic impact of creators such as Issey Miyake, Rei Kawakubo, and Yohji Yamamoto. Born just before and during World War II, they became some of the most important fashion figures to chart a new course since the 1970s. Their use of oversized silhouettes, cutting-edge textiles, and the appropriation of Japanese aesthetic principle like *sabi/wabi* have made them leaders of the avant-garde.

See also **Asia, East: History of Dress; Cashin, Bonnie; Europe and America: History of Dress (400–1900 C.E.); Kimono; Vionnet, Madeleine.**

#### BIBLIOGRAPHY

- Evett, Elisa. *The Critical Reception of Japanese Art in Late Nineteenth Century Europe*. Ann Arbor, Mich.: UMI Research Press, 1982.
- Fukai, Akiko, and Jun Kanai. *Japonism in Fashion*. Kyoto, Japan: Kyoto Costume Institute, 1996.
- Grand, France. *Comme des Garçons*. New York: Universe Publishing, 1998.
- Hiesinger, Kathryn B., and Felice Fisher. *Japanese Design: A Survey Since 1950*. New York: Harry N. Abrams, 1995.
- Issey Miyake: *Ten Sen Men*. Hiroshima: Hiroshima City Museum of Contemporary Art, 1990.
- Kirke, Betty. *Madeleine Vionnet*. San Francisco: Chronicle Press, 1998.
- Kondo, Dorinne. *About Face: Performing Race in Fashion and Theater*. New York: Routledge, 1997.
- Koren, Leonard. *New Fashion Japan*. Tokyo: Kodansha International, 1984.
- . *Wabi Sabi for Artists, Designers, Poets and Philosophers*. Berkeley, Calif.: Stone Bridge Press, 1994.
- Martin, Richard, and Harold Koda. *Orientalism*. New York: Metropolitan Museum of Art, 1994.
- Martin, Richard, Harold Koda, and Laura Sinderbrand. *Three Women: Madeleine Vionnet, Claire McCardell, and Rei Kawakubo*. New York: Fashion Institute of Technology, 1987.
- Sudjic, Deyan. *Rei Kawakubo and Comme des Garçons*. New York: Rizzoli International, 1990.
- Vreeland, Diana, and Irving Penn. *Inventive Paris Clothes: 1909–1939*. New York: Viking Press, 1977.
- Wichmann, Siegfried. *Japonisme: The Japanese Influence on Western Art in the 19th and 20th Centuries*. English translation. New York: Harmony Books, 1981.

Patricia Mears

**JEANS** “Blue jeans” are the archetypal garment of the twentieth century. They are traditionally ankle-length, slim-fitting trousers made of blue denim worn for labor and casual dress. The term “jeans,” or “blue jeans,” has been in widespread usage since the mid-twentieth century.

The word “jeans” comes from the word *Génes*, the French word for Genoa, Italy, where sailors were known

to wear sturdy pants of fustian, a sturdy twill of cotton, linen, or wool blend. By the sixteenth century, the fabric was being referred to as “Jene Fustyan.” By the eighteenth century, jean fabric was made entirely of cotton and was being used to make work clothes. Jean was available in many colors, but often dyed with indigo. Pants made from jean were often referred to as “jean pants,” the origin of the contemporary jeans.

Jeans, however, are made of denim. Denim is also a sturdy cotton twill, similar to jean, but even stronger. Denim is traditionally yarn-dyed and woven with an indigo-blue face and a gray or unbleached fill. This method of manufacture enables denim to develop distinctive areas of fading and wear with usage. It is commonly believed that the name “denim” is an Anglicised name for *serge de nîmes*, a French fabric dating back to the seventeenth century. While this attribution has been popular and widely disseminated, it has recently been called into question. *Serge de nîmes* and a second French textile known simply as “nim” were mainly wool, not cotton. The sturdy cotton twill now recognized as denim was originally given the name “denim” in eighteenth-century England. It has been theorized that the French name was given to an English product to add prestige.

To confuse the matter even further, jeans are sometimes referred to as dungarees. This term refers to a coarse calico fabric that was often dyed blue and used to make work pants. The word “dungaree” would later describe the pants as well.

### Miners and the Workingman

The first true “jeans” were created in 1873 by Jacob Davis, a Nevada tailor, who went in with Levi Strauss, a San Francisco merchant, for the patent. The pair received a patent for the addition of copper rivets at the pocket joinings of work pants to prevent tearing—a boon to the many California miners and laborers. The first jeans Levi-Strauss and Co. produced were available in brown cotton duck and blue denim and were known as waist overalls (the name jeans not adopted until the mid-1900s). In the late nineteenth century, Levi’s (as they became known) began to acquire their hallmarks: the leather “Two Horse Brand” patch, lot numbers, and back patch pockets with distinctive stitching. The Levi’s “501,” which originated in 1890, is considered by many to be the archetypal pair of blue jeans.

Levi-Strauss had cornered the market with their denim pants, but competitors moved quickly. Companies manufacturing similarly styled denim work pants entered the market. These included OshKosh B’Gosh in 1895 and Blue Bell in 1904, which later became Wrangler. The Lee Mercantile began production of their waist overalls in 1911 and enjoyed their first great success with the Lee Union-All in 1913. During World War I, Union-Alls were standard issue for all war workers, and the design was modified for the doughboy uniform.

### Hollywood, Cowboys, and Wartime

During the 1920s and into the 1930s, the image of the waist overall was given a glamorous spin by handsome cowboy movie stars like Tom Mix, John Wayne, and Gary Cooper. In 1924 H. D. Lee Mercantile Co. introduced their 101 cowboy pants, which were designed to meet the needs of cowboys, rodeo riders and others looking for authentic western garb. The 101 cowboy pant was given a facelift in 1941 when Sallie Rand, the wife of famous rodeo champion Turk Greenough, recut them for a tighter fit. These new and improved cowboy pants were then called Lee Riders. The romanticized view of the cowboy life seen onscreen brought about an enthusiasm for dude-ranch vacations, and tourists brought back comfortable waist overalls as souvenirs. This glamorous new image was reinforced by publicity photos featuring actresses like Ginger Rogers and Carole Lombard wearing the humble waist overalls while camping and fishing. Through these glamorous associations, the waist overall became associated with leisure and rugged individualism rather than manual labor. Young people began to adopt them into their casual dress, wearing them rolled up and baggy.

World War II would change the image of the waist overall forever. Raw materials were restricted for the war effort, and the general silhouette was slimmed down to reduce fabric consumption. As a result of these restrictions, Levi’s lost their back cinch and copper crotch rivet while the stitching on the back pocket was painted on to conserve thread. Denim began to be used as a fashion fabric by fashion designers like Claire McCardell, whose denim wrap dress, the “popover,” sold in the thousands.

American GIs brought jeans overseas with them to wear while off-duty. This had an important impact on the international reputation of jeans; they became associated with American leisure and abundance, especially in countries devastated by the war. To many, blue jeans were an important symbol of freedom and wealth.

### Post-World War II Leisure and Rebellion

Blue jeans would continue to be associated with leisure in the post-World War II period. The term “jeans” became widely adopted during this time, and jeans began to be marketed specifically to the youth market. In 1947, Wrangler introduced the slim “body fit” jeans, which emphasized fit and appearance over traditional qualities like durability. In 1949, Levi Strauss and Co. opened an outlet in New York, and began nationwide promotion of their waist overalls, which they grudgingly began to call “jeans” in 1960. In 1953, H. D. Lee (formerly Lee Mercantile Co.) began an advertising campaign aimed at teenagers. Lee Riders were transformed into a slimmer “drainpipe” style popular with teens.

Once again, Hollywood films had an important role in the reinvigoration of the image of the utilitarian waist overall. While young children continued to idolize the cowboy, teenagers found new denim-clad idols in Marlon Brando (*The Wild One*, 1953) and James Dean (*Rebel*



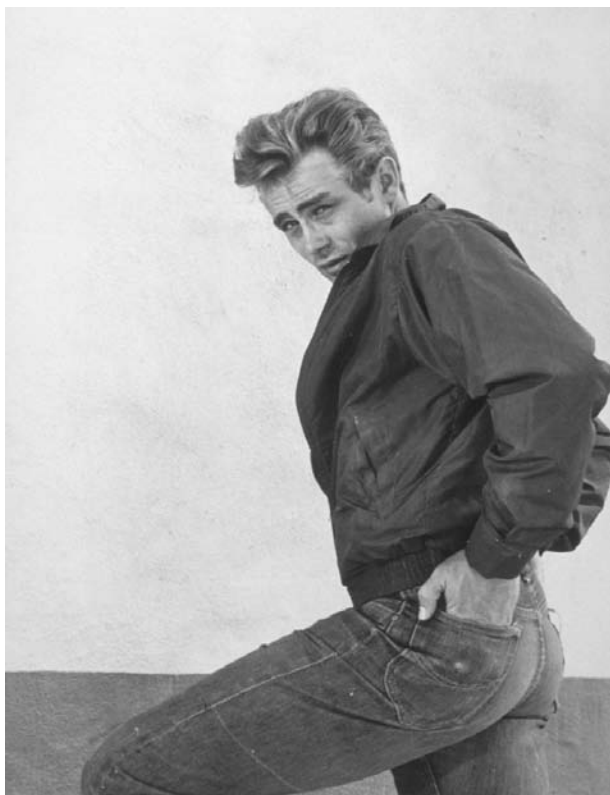

**Actor James Dean in jeans.** The entertainment industry did much to promote the popularity of blue jeans in the 1950s, associating them with rock stars and sexy film rebels. © SUNSET BOULEVARD/CORBIS SYGMA. REPRODUCED BY PERMISSION.

*Without a Cause*, 1955). Denim now had a dangerous element and a healthy dose of sex appeal. Exciting new rock'n'roll musicians like Eddie Cochran, a Levi's devotee, also played a role in the popularization of denim. This rebellious association caused jeans to be banned from many high schools throughout the 1950s, but this only strengthened their popularity.

The 1960s saw an explosion of the production and acceptance of jeans as leisure wear. Denim as a fashion fabric also became widely accepted, and the important contribution denim jeans had made to fashion and popular culture began to be acknowledged. In 1964, it was boldly stated in *American Fabrics* magazine:

Throughout the industrialized world denim has become a symbol of the young, active, informal, American way of life. It is equally symbolic of America's achievements in mass production, for denim of uniform quality and superior performance is turned out by the mile in some of America's ... most modern mills. (*American Fabrics*, No, 65, 1964, p. 30)

With this mass acceptance came the need for distinction. Early in the 1960s, slim-fitting styles dominated but were superseded by the well-worn bell-bottom styles popularized by the hippie movement. The wearing of

jeans was both a political and social statement and the baby boomers embraced the aesthetic of customized decorated denim. Embroidery, paint, and appliqué on faded bell-bottom jeans became a powerful symbol of anti-establishment ideals around the world.

### Designer Jeans

Since jeans and denim-inspired fashions were everywhere in the 1970s, this period has been called "the golden age of denim." The customization of jeans continued and reached its pinnacle with Levi's Denim Art Contest of 1973. Mass-produced jeans echoing the earthy styles worn by political activists and rock stars, and the traditional workingman's garb, the overall, became popular.

Increasingly though, denim jeans reflected a new sophistication. Early inroads were made by the Italian company Fiorucci with their Buffalo 70 jeans. Buffalo 70 jeans were skintight and dark, the opposite of the faded bell-bottoms worn by most consumers. Since they were also expensive and difficult to find, they became a status symbol among the Studio 54 set. Their success paved the way for the high-end designer jean market of the early 1980s. American socialite Gloria Vanderbilt introduced her jeans in 1979. Similar in styling to the Fiorucci Buffalo 70 jeans, they also featured dark denim, a slim fit that emphasized a woman's curves and a bold designer logo on the rear pockets. They were significantly more expensive than other jeans and were promoted as being "high fashion." The jeans used the glamour and celebrity of socialite Gloria Vanderbilt to promote them, rather than emphasizing their practicality or styling.

This type of marketing strategy would become increasingly important during the 1980s, since there soon was a deluge of similarly styled "designer" jeans on the market. Advertising had the ability to make or a break a brand's success, and this trend has continued. Designer jeans lines from this period included Jordache, Sassoon, Sergio Valente, and the legendary Calvin Klein Jeans. In 1980, Calvin Klein Jeans embarked on a now-legendary ad campaign featuring fifteen-year-old model Brooke Shields, who cooed provocatively, "Nothing comes between me and my Calvins." The public outcry was great, but Calvin Klein Jeans sales rose from \$25 million to \$180 million in the span of one year. During the next decade, sexy marketing campaigns became standard. Some of the most successful were advertisements for Guess? Jeans that featured sultry models like Claudia Schiffer in seductive poses.

The jeans market grew increasingly fragmented during the 1980s. What had been the uniform of youthful rebellion and social protest during the 1950s and 1960s was now seen as a wardrobe basic and worn by all age groups. The many different styles offered included pinstriped, acid-washed, stonewashed, cigarette cut, two-toned, stretch, and pre-ripped. With this focus on innovation and novelty, many traditional denim manufacturers languished. The designer denim movement continued into the 1990s when well-established fashion



**Advertisement featuring Brooke Shields in Calvin Klein jeans.** In 1976, designer Calvin Klein became the first fashion designer to showcase blue jeans on the runway. AP/WIDE WORLD PHOTOS. REPRODUCED BY PERMISSION.

houses like Versace, Dolce & Gabbana, and Donna Karan branched out into denim.

### Vintage Denim and Retro Styling

After more than a decade of designer jeans of various finishes, denim saw a return to classic styles, dark denim, and dangerous rebellion. Dark denim returned to mainstream popularity during the 1990s, a dramatic change from the pale, fluffy denim being produced throughout the 1970s and 1980s. Dark denim was stiff and was often worn with cuffed hems in the style of a 1950s bobby-soxer. Dark denim was seen as intellectual and ironic, a deliberate throwback to the essential elements of mid-century jeans. Traditionally styled dark denim was given an additional boost by the popularity of hip-hop. The hip-hop styles of the early 1990s were characterized by oversized, low-slung baggy jeans, associated with convicts forced to turn in their belts. Manufacturers like Ben Davis and Carhartt prospered since their no-frills, dark denim work clothes appealed to this hard-edged prison aesthetic and were prominently featured in music videos and lyrics by artists such as Dr. Dre and Snoop Dogg. Based on styles popularized by the hip-hop community, urban sportswear labels like FUBU, Rocawear, and Phat Farm

emerged. Mainstream labels like Tommy Hilfinger and Polo Jeans were also appropriated in this style.

At the same time, vintage denim was experiencing a renaissance. By the late 1980s, the simple garment of the mid-century had been bastardized by the glut of fashion jeans on the market. To many consumers, vintage denim symbolized strength and integrity, a direct challenge to the perceived corruption of the 1980s. Increasingly the wearing of vintage denim became popular, and prices for original Levi's, Wranglers, and Lees soared. Others turned to faithful modern renditions of vintage denim. Evis Jeans, a Japanese company, made their name during the early 1990s by producing modern versions of classic denim, like the Levi's 501 and the Lee 101 with a twist. In 1999, Levi Strauss and Co. launched the "Red" line, a successful series of high-priced reproductions of vintage styles. Likewise, Lee jeans produced a replica of their highly collectible "hair on hide" cowboy pants for the Japanese market. Jeans, at least for the moment, had returned to their roots.

During the 1980s, smaller, higher-priced lines began to experiment with vintage-styled denim, paving the way for the vintage-inspired denim explosion of the

1990s. Adriano Goldschmied, founder of the influential “genius group” of denim innovators, was an early proponent of sandblasted knees and painted on “cat’s whiskers” (the wear pattern at the crotch of vintage jeans). The genius group would become hugely influential, spawning many denim labels, such as Diesel and replay, whose higher priced lines provided finishes that the coveted striations and fading that characterized vintage denim. By the mid-1990s this aesthetic had gone mainstream as seen by success of “Dirty Denim” produced by designers such as Helmut Lang and Calvin Klein. The denim craze has continued into the twenty-first century with cult denim lines like Mavi, Paper Denim and Cloth, Seven, and Blue Cult all competing in the marketplace with perfectly faded, whiskered, and creased jeans.

Jeans, the ubiquitous twentieth-century garment, will undoubtedly continue to have a permanent place in twenty-first-century wardrobes around the world. Their iconic status will remain intact, largely since they will be reinterpreted by each passing generation. In 1983, legendary French couturier Yves Saint Laurent told *New York Magazine*, “I have often said that I wish I had invented blue jeans. They have expression, modesty, sex appeal, simplicity—all that I hope for in my clothes” (*New York Magazine*, November 28, 1983, p. 53).

See also **Denim**; **Klein, Calvin**; **Strauss, Levi**.

#### BIBLIOGRAPHY

- Downey, Lynn, et al. *This Is a Pair of Levi’s Jeans: The Official History of the Levi’s Brand*. San Francisco: Levi Strauss and Co. Publishing, 1997.
- Finlayson, Iain. *Denim: An American Legend*. New York: Simon and Schuster Inc., 1990.
- “The Genius of Yves Saint Laurent.” *New York Magazine* (28 November 1983): 53.
- Gordon, Beverly. “American Denim: Blue Jeans and Their Multiple Layers of Meaning.” In *Dress and Popular Culture*. Edited by Patricia A. Cunningham and Susan Voso Lab. Bowling Green, Ohio: Bowling Green State University Popular Press, 1991.
- Hall, Lee. *Common Threads: A Parade of American Clothing*. Boston: Little, Brown and Company, 1992.
- Harris, Alice. *The Blue Jean*. New York: Powerhouse Books, 2002.
- Hay, Ethan. “Jeans.” In *St. James Encyclopedia of Popular Culture*, vol. 2: E–J. Edited by Tom Pendergast and Sara Pendergast. Detroit: St. James Press, 2000.
- Marsh, Graham, and Paul Trynka. *Denim: From Cowboys to Catwalks: A Visual History of the World’s Most Legendary Fabric*. London: Aurum Press Limited, 2002.
- Musées de la Ville de Paris. *Histoires du jeans de 1750 à 1994*. Paris: Paris Musées, 1994.
- “Stretch Denim: Bright Star in the Modern Family of Stretch Fabrics” (Special merchandizing insert). *American Fabrics*, no. 65 (Fall 1964): 30.

Clare Sauro

**JERSEY** Jersey is a weft-knit fabric that is also called plain knit or single knit. Some sources claim the term “jersey” is used loosely to refer to any knitted fabric without a distinct rib. It is called jersey because it was manufactured on the island of Jersey off the coast of England. This early version of the fabric was used for fishermen’s clothing and was a heavier weight fabric than the jersey fabrics of the early 2000s. The related term in current usage used to describe athletic shirts is from a similar origin. The tight-fitting, knit tunic-style sweaters worn by seamen were also known as jerseys.

Jersey can be made by hand or on flat and circular knitting machines. Jersey knits are made from the basic knitting stitch, in which each loop is drawn through the loop below it. The rows of loops form vertical lines, or wales, on the face of the fabric and crosswise rows, or courses, on the back. Jersey knits are lightweight in comparison with other knits and are the fastest weft knit to produce. Jersey stretches more in the crosswise direction than in length, may be prone to runs, and curls at the edges because of the difference in tension on the front and the back.

Historically, jersey was used mainly for hosiery and sweaters. However, as early as 1879 the actress Lillie Langtry, “the Jersey Lily,” made jersey fashionable for daywear. Her costume was made up of a tight-fitting, hip-length jersey top that was worn over a pleated skirt. In the 1920s Gabrielle Chanel popularized the fabric for comfortable womenswear, constructing dresses and suits out of it.

Jersey may be finished with napping, printed, or embroidered. Variations of jersey include pile versions of the knit and jacquard jersey. Pile jerseys have extra yarns or sliver (untwisted strand) inserted to make velour or fake-fur fabrics. Jacquard jersey incorporates stitch variations to create complex designs that are knitted into the fabric. Intarsia fabrics are jersey knits that use different colored yarns to produce designs and are more costly to produce than printing the design as a finish.

Jersey is used to make hosiery, T-shirts, underwear, sportswear, and sweaters. It has also been incorporated into the home furnishings market and is used for bedding and slipcovers.

See also **Napping**.

#### BIBLIOGRAPHY

- American Fabrics Encyclopedia of Textiles*. 2nd ed. Englewood Cliffs, NJ: Prentice Hall, 1972.
- Calisbetta, Charlotte M., and Phyllis Tortora, eds. *The Fairchild Dictionary of Fashion*. 3rd ed. New York: Fairchild Publishing, 2003.
- Gioello, Debbie Ann. *Profiling Fabrics: Properties, Performance and Construction Techniques*. New York: Fairchild Publishing, 1981.



Jerde, Judith. *Encyclopedia of Textiles*. New York: Facts on File, 1992.

Kadolph, Sara J., and Anna L. Langford. *Textiles*. 9th ed. Englewood Cliffs, N.J.: Prentice Hall, 2002.

Wingate, Isabel, and June Mohler. *Textile Fabrics and Their Selection*. 8th ed. Englewood Cliffs, N.J.: Prentice Hall, 1984.

#### *Internet Resource*

“Plain Stitch.” *Encyclopedia Britannica*. Available from <<http://search.eb.com/eb/article?eu=61814>> (subscription required).

*Marie Botkin*

**JEWELRY** Jewelry is often associated with treasure—gold, gemstones, valuable materials—and is considered to be objects of intrinsic beauty, though the early beginnings were very different. In prehistoric times, long before humans worked metals, jewelry was made of non-precious materials. Burials of 30,000 B.C.E. in Europe show that at the time people used local materials available to them, such as shells and pebbles, and, in hunting societies, also animal teeth and claws, to make jewelry. Existing examples reveal that pieces were engraved with intricate geometric patterns and, later, zoomorphic images. Thus, jewelry was an early form of decorative art. The study of some primitive cultures gives evidence that organic materials, which have since disintegrated, would have also undoubtedly been utilized in the past. It was not until a later stage of human development that people chose precious and possibly scarce materials from far-away for jewelry.

Jewelry is as old as humankind. Whether coming from a primitive culture or modern civilization of the West or East, and regardless of material and style, humans of both genders and all age groups have the need for self-adornment. The significance of jewelry transcends time limits and geographic boundaries; similarities in the use of jewelry for personal adornment become apparent in the study of various cultures.

In prehistoric times, as well as in contemporary cultures, jewelry is not only ornamentation for the body, but also a means of communication. Hierarchy, prestige, and power are expressed through jewelry, which can affirm the status of an individual in society. What initially appears to be an ornament can mark allegiance to a society or individual. Men and women can impress each other through jewelry. Yet possibly the most powerful qualities attributed to jewelry are the amuletic and talismanic functions of warding off evil or giving luck. These properties go back to the origins of jewelry and continue well into the nineteenth century. Even in contemporary cultures people carry good-luck charms. Jewelry also played an important role in protecting against the dangers of life, and was given in burials for the afterlife of the deceased. In addition, jewelry was also worn as a sign of personal affection and fidelity, and marked special occa-

sions in life, such as coming of age, association to a religion through communion or confirmation, nobility, marital status, and motherhood. Jewels in their aesthetic expression are not only signs of wealth and taste, but also reflect—and communicate—the personal character and temperament of the wearer.

Throughout its history until about the mid-twentieth century, when jewelry experienced a radical change, it had been dependent on the fashions of the day, with the exception of finger rings. Varying necklines, sleeve lengths, hemlines, and fabrics determined the type of jewelry worn, while the choice of materials and symbolism determined its function and usage. The creativity of the goldsmith is boundless, as are the types and styles of wearable objects for the body.

If not passed on as a family heirloom or given for the person's afterlife and found in excavations of burials, many types of jewels that are known to have existed have not survived. Jewelry made of precious materials, regardless of century or culture, have been destined to be dismantled, the gemstones reused and the metals such as silver and gold melted down for bullion, either to become a financial resource or to be remodelled in a new fashion. Jewels with enamel have withstood this destiny, as it was too complicated and costly to remove the enamel, whereas golden chains with a considerable weight in metal were the first to be melted down. Few images of jewelry types and how they were worn survive from antiquity. Mummy masks and wall paintings of the ancient Egyptian era, ancient Greek statues of gods and vase painting, Etruscan tomb sculpture, Roman tombstones, and the informative mummy portraits of Fayum from the Roman period all give valuable evidence. In the Middle Ages, tomb effigies and even religious paintings of the Virgin Mary and saints illustrate jewelry of the time. More importantly, the development of portrait painting and the depiction of the individual from the fifteenth century onwards (supplemented after the mid-nineteenth century by photography) enables a comprehensive study of jewelry, and makes possible the reconstruction of many types that are no longer in existence.

In prehistoric times people chose materials from their immediate environment. A statuette dating back to 20,000 B.C.E., the so-called “Venus of Willendorf,” shows a fertility statue wearing a bracelet, and burials give evidence of the use of necklaces made of snails and shells—both fertility symbols and a sign of motherhood. Men wore animal teeth and claws to signify their strength over the animal kingdom and their ability to hunt and, in turn, feed and protect their families. Such objects would possibly have marked their position within the community. In its early stages, jewelry was predominantly amuletic—its function was to guard its wearers in a life of hardships.

Until recently, and even to a limited extent in the early 2000s, among traditional peoples who managed to resist the impact of Western religion and culture, it is

possible to discern elements of these more traditional attitudes toward personal adornment. Tattoos, makeup, and jewelry were in many cases, in such societies, not simply matters of personal adornment, but also conveyed specific messages about social and gender roles; they were used to ward off disease and other evils, and sometimes also to work magic against opponents; and as acts and signs of prayer and devotion to divinities. A widespread, if attenuated, example of the magical power of jewelry can be found throughout the Middle East and in parts of Africa, where the wearing of blue glass beads as a means of warding off the “evil eye” is very common.

In some societies, Western-style jewelry has still not completely effaced the wearing of more traditional forms of jewelry. The use of natural materials in jewelry in ways that probably preserve a very long continuous tradition of craftsmanship can be found, for example, among the highland peoples of New Guinea, where shell, bird-of-paradise feathers, boar tusks, and other animal products are commonly employed in personal adornment. Until the second half of the twentieth century these elements of jewelry were ubiquitous in the absence of alternative materials (for example, metal objects); in the early twenty-first century their continued use represents a choice among a wide range of possibilities.

In other contemporary non-Western societies, jewelry can still be seen as fulfilling another of its ancient functions, that is, it acts as a repository of wealth while also retaining its amuletic properties. Among pastoral nomadic peoples in the steppelands of Asia, throughout the Middle East, and in North Africa, women commonly wear very heavy silver jewelry, including headdress ornaments, earrings, necklaces, bracelets, belts, and frontlets, sometimes including actual silver coins (of many eras and many countries) worked into the jewelry. These coins also had an amuletic function, because their jingling sound was believed to ward off evil. Such jewelry not only displays the status of the family to which the woman belongs, but also acts as a highly portable form of wealth that can be converted to monetary use at any time it is needed. Likewise, in cities and agricultural regions of the Middle East, India, and Southeast Asia, gold jewelry acts as a repository of wealth as well as being beautiful and prestigious. In many Indian communities, for example, the conspicuous wearing of gold jewelry by a bride is an essential element of a wedding ceremony.

Jewelry found in western Asia in the cradle of civilization from about 5000 to 2500 B.C.E. illustrates a society with a taste for refined and decorative jewelry, as well as a trade network in supplying rare materials for their goldsmiths and differing local traditions. The earliest examples were necklaces made of obsidian from Turkey and cowrie shells with red stain from the nearby coastal areas. The most splendid jewels found in the area were from the royal graves of the Sumerian city of Ur in southern Mesopotamia, where the king and queen lay

buried accompanied by their soldiers and attendants. Men wore beads to keep their headdress in place, whereas women’s jewelry was more elaborate with dress pins, headdresses, and necklaces made of embossed and repoussé gold, probably from the areas currently known as Iran and Turkey. The motifs were stylized flowers and foliage, interspersed with beads in varying geometric shapes cut from lapis lazuli imported from Afghanistan and carnelian from India. The designs are intricate with signs of inlay, filigree, and the use of alternating colors.

Like the Sumerians, the ancient Egyptians from 3100 B.C.E. till the Graeco-Roman period in the first century B.C.E. showed a preference for lapis lazuli and carnelian, and typically, in Egyptian jewelry, turquoise is added to this combination. The resources in the area were vast and the choice of materials for the Egyptian jewelry-maker amazing as they also included a variety of organic materials. Gold and many other metals were found in the surrounding areas as were agates, amethysts, garnets, jaspers, malachite, and steatite, to name but a few. Glazed faience, and glass imitations in substitution, were applied to achieve colorful compositions, forming a contrast to the rather plain clothing the Egyptians wore, which was essentially made of white linen. Pectorals and necklaces were the most popular of jewelry types, but bracelets and head ornaments of all sorts are characteristic for the culture. The motifs ranged from the animal world (including fish and lions), the magical scarab, sphinxes, the *udjat* eye, and deities, either signifying rank or serving an amuletic purpose. Other designs are of a more decorative nature with vivid color combinations achieved through varied bead shapes and stones. Pharaohs, princesses, peasants, and artisans alike wore jewelry in life and in death, many surviving types were in fact funerary objects. The jewelry-making techniques were most sophisticated, such as inlaying in cloisons and granulation, and we even have pictorial records of craftsmen from ancient Egypt demonstrating technical processes in their workshops.

In the eastern Mediterranean of about 2500 B.C.E. there was the Minoan culture in Crete, which was taken over by the Mycenaeans in about 1450 B.C.E. The jewelry of that period and area is characterized by an abundance of gold; their styles were greatly influenced by the jewelry of the Babylonians and Egyptians. The Phoenicians were traders who colonized the eastern and western Mediterranean from Syria to Spain, and their choice of jewelry was influenced by the ancient Egyptians. Near Eastern designs also had influence on the later Greeks, as seen in the Orientalizing style of the Archaic period (700–480 B.C.E.), and in Etruscan jewelry (seventh to fifth centuries B.C.E.). The Etruscans were known for their technical perfection in goldsmithing and most of all for their outstanding technique of granulation with almost pulverized granules of gold. By the seventh century B.C.E., however, forms and decorative elements in jewelry were dominated by Greek designs and symbols.

Greek goldsmiths of the classical to Hellenistic periods were renowned for their technical skills and fine craftsmanship mainly in gold—a reputation that would be retained in future centuries. Greece was not rich in gold resources until its empire was extended as far as Persia in the fourth century B.C.E. In the classical period, from the Crimea to as far west as Sicily, Greek men wore more jewelry in some areas than others. In certain places it was even considered to be effeminate. Jewelry were gifts presented at birth, birthdays, and weddings, or even as votive offerings to cult statues. Rings and hair wreaths adorned men, both men and women wore rings, and the main forms of adornment for women were necklaces, earrings, bracelets on their upper arms or thighs, and diadems or golden nets in their hair. Fibulae were widespread and not only a decorative feature, but functional in as much as they held the drapery of the chiton on the shoulder. As the iconography of Greek jewelry confirms, it was intended for women, mainly to attract the opposite sex. This may explain the numerous images of Aphrodite, the goddess of love, in gold, as three-dimensional figures suspended from necklaces or earrings, possibly given at the birth of a child. Eros, symbolic of desire, was equally popular and given as a token of love. Deities such as Athena or Dionysus or other figures from mythology referred to religious beliefs and the power of the deities during life. Bracelets worn in pairs on the upper arm or rings with elaborately coiling snakes functioned as amulets, calling on the sacred creatures of the underworld to protect against evil. Antelopes and goats would attract the opposite sex, whereas lions were worn as emblems of fertility and royal power. These decorative motifs were all rendered in a naturalistic manner in gold sheet metal with intricate filigree wires and granulation, as were the interspersed motifs from nature such as seeds, nuts, and different shapes of foliage. Enamels, garnets, emeralds, and glass pastes became fashionable during the Hellenistic period as beads or inlay to add color to the previously predominantly gold jewelry.

With the loss of Greek independence and the victory of the Romans over Macedonia in 168 B.C.E, Rome became a strong military and political power. The wealth of the new empire attracted many Greek craftsmen to come to the capital, where they were most successful. Essentially the Romans followed Greek styles until about the first century B.C.E, when the aesthetics of their jewelry began to change. The jewelry became unpretentious, the gold techniques less elaborate, the designs simplified, and more emphasis was laid on the choice of stones and the use of color—a new taste had developed, it was the beauty of the material to which one aspired. Regional differences are evident: jet was fashionable in Britain, where it was found in Whitby, and amber from the Baltic Sea was cut in Aquileia in Roman Italy. Emeralds from the newly discovered mines in Egypt—what was then recently acquired Roman territory—became fashionable and their abundance led to the natural hexagonal crystal



**Bracelet by René Lalique.** Lalique began designing jewelry in the late 1880s and was known for his unique combinations of metals, glass, and gemstones. AP/WIDE WORLD PHOTOS. REPRODUCED BY PERMISSION.

shapes being drilled, strung on thread, or connected with simple gold links to be worn as necklaces. Garnets were imported from the Middle East, and sapphires from Sri Lanka. Pearls were considered to be an expression of luxury and indulgence. Apart from the Romans showing a preference for gemstones, each has a special significance, described in the *Historia naturalis* by Pliny the Elder (23–79 B.C.E). Specific gemstones were chosen for certain images, such as Bacchus on amethyst as a safeguard against drunkenness; the Sun god Sol is depicted on heliotrope; and Demeter, goddess of crops, on green jasper to symbolize growth and abundance.

Trade was flourishing in the vast empire with far-reaching provinces, and jewelry was being produced in Rome, Alexandria, and Antioch. Roman goldsmiths had guilds and rules existed about who could wear certain types of jewelry, but these soon diminished. During the Republic gold jewelry was reserved for the aristocracy, but by the first century C.E. its significance soon depreciated and by the second century gold was worn by those who could afford it. With adornment becoming socially acceptable for a wider public, even slaves were permitted to wear jewelry made of iron—it was mass produced, and thus plenty has survived from the Roman period. With a thriving economy by the second century, Roman jewelry became more elaborate, even heavy and gaudy—a sign of wealth and status—yet at the same time the iconography suggests the jewelry was full of symbolism and personal messages for the wearer. Deities became symbols of wealth and good fortune, the gorgon Medusa destroyed evil powers, the phallus was a popular good luck charm, and cupids with Venus or cupids riding on dolphins tokens of love. Images of clasped right hands or husband and wife facing each other alluded to the mar-





**Detail from Titian's *Girl in a Fur*.** The Renaissance lady in this painting wears pearls, which were a popular, if expensive, jewelry choice during the period. © BURSTEIN COLLECTION/CORBIS. REPRODUCED BY PERMISSION.

riage vows, and Latin inscriptions served as charms to protect life. Other types of jewelry such as the brooch were more decorative in character and, in fact, served a functional purpose of holding the drapery together.

By the fourth century the Roman Empire was in decline. With Christianity having been recognized by Constantine the Great, the iconography found in jewelry was relevant to the new religion, but often coded to protect the owner from being persecuted. The early Christians appear to have worn finger rings as a sign of their allegiance, and engraved on the bezels are symbols and ciphers of Christ the Saviour. In the fourth century the empire transferred to East Byzantium with its capital in Constantinople, which continued as an ecclesiastical and successful trading power until 1453 when the city fell to the Ottoman Turks. Greek goldsmiths were active there, and with their influence, despite the style being a continuation of late Roman jewelry with a love for gemstones and color, there was a greater emphasis on intricate goldwork with enamel or niello decoration. Except for bronze

gilt or gold rings, the laws were strict about who could wear jewelry. Emeralds, pearls, and sapphires were reserved for the emperor, and all the splendor of their richly embroidered and bejeweled fabrics is documented in the mosaics of the churches in Ravenna, northern Italy, as are the elaborate necklaces, earrings, and brooches. Nevertheless, the iconography was religious and the cult of saints is confirmed by the use of pectoral crosses with their images and relic inserts.

Mutual artistic influence between the Byzantine world and the expanding world of Islam is evident from the mid-seventh century onward. Byzantine and Islamic influence can also be seen in the jewelry of the Germanic tribes that occupied much of Europe after the fall of the western Roman Empire. Germanic tribesmen acquired gold from Byzantium. The jewelry of these nomadic tribes tended to be restricted to basic types and was more functional in its application, but nonetheless the jewels were a statement of status. Men wore belts, buckles, and sword harnesses; both men and women needed clasps for their dress, and these are found in the form of disc brooches or fibulae. The tribes show distinctive styles in their goldsmiths' work, but even they had many common elements, such as sophistication in the applied goldsmithing techniques, the lavish engraving, the use of garnet inlays, and the intricacy of patterns, including stylized animal themes.

During the Middle Ages cities were enlarging, the merchant classes were gaining prominence and becoming a new economic force, and with the church losing power, society became more worldly. With the rise of the middle classes and increase in wealth, sumptuary laws became necessary to restrict who was allowed to wear jewelry. Fashions determined the types of jewelry worn: with the sleeves becoming wider and more lavish, bracelets were unnecessary; high collars did not allow for earrings; cape-like coats required brooches; and the high waistlines of women's dresses made fancy belts necessary. Rings with signets or love messages were very popular.

By the twelfth and thirteenth centuries an international style in jewelry had evolved. Shapes of stone settings, designs, and decorations showed astonishing similarities in England, France, Denmark, Germany, and Italy. This phenomenon presumably can be explained by the trade routes and import of gemstones from the Near and Far East. Paris was trend-setting in the manufacturing of jewelry, whereas the ports of Venice and Genoa were influential in trade. The inscriptions on jewelry were mostly in Latin or French, the international language of the courts. The pointed arches and tracery of Gothic architecture, naturalistic rendering of foliage in sculpture, and the colors of stained glass were mirrored in the jewelry designs of the time. Devotional and secular iconography were often interlocked, gemstones in cabochon were amuletic or reflected divinity, and the images of saints had protective and healing powers, as did the emerging use of the bones of saints in reliquary pen-

dants. Flowers and animals decorate medieval jewels as a symbol of faith, and classical gems were given Christian interpretations. Medieval jewelry was largely heraldic, religious, or expressive of courtly love.

In Europe the transition to the Renaissance period differed according to country, beginning with Italy in the fifteenth century and spreading throughout Europe by the sixteenth century. Italy, with its discoveries of ancient monuments and sculpture, was all-important in the re-birth of the cultures of ancient Greece and Rome, whereas in northern Europe Gothic styles continued much longer. With an explosion of economic trade, in particular wool and banking, many wealthy families in Italy became patrons of the arts. Goldsmiths became known as individuals by name. In the fifteenth century, Florence and the Burgundian Courts established trends in dress and jewelry; by the sixteenth and seventeenth centuries Spain became a major European power with colonies all over the world, leading to a dominant Spanish style in dress and jewelry. Religious wars raged in Europe and, often due to the circumstances, artisans traveled from one country to another—at the same time following the wealth of emerging courts in Europe. Jewelry again developed into an international style with less regional distinctions. Another factor that led to this phenomenon was the newly discovered art of printing. Artists made ornamental drawings that were printed and distributed throughout Europe, and even as far as the Spanish colonies, where jewelry was made in the style of the day for trade with Europe.

Men, in fact, showed more adornment than women. However, the function of jewels was display, as the abundance of portraits of that period document. The merchant classes were following fashions of the aristocracy, the materials used, though, were usually less precious. The heavy and dark velvets or brocades with gold embroidery were covered with jewelry, either sewn on the fabric as ornaments, or worn on the body. Pendants were fashionable for all genders, and the images were either religious or from classical mythology; exotic birds, flowers, or marine themes were also displayed as symbols of status and new wealth. Gemstones were in open settings when on the body, so that the amuletic qualities would be more effective. Heavy gold chains worn by both men and women on the breast or across the shoulder and cascading in multiple strands were undoubtedly a sign of social ranking. Men wore hat jewels, belts with sword harnesses, and jeweled buttons. The custom of wearing bracelets in pairs was revived from antiquity, as was the fashion for earrings. Decorative chains encompassed ladies' waists, often from which pomanders or pendants were suspended. Dress studs ornamented the already elaborate fabrics. To add to the display of color, Renaissance jewels often had polychrome enamels in combination with gemstones, such as rubies from Burma, emeralds from the New World, pearls off the coast of Venezuela, and diamonds from India. In contrast to the



**Indian woman with nose ring.** Silver and gold are signs of prestige in India, and among nomadic tribes jewelry made from these metals functions both as adornment and as portable wealth. © BRIAN A. VIKANDER/CORBIS. REPRODUCED BY PERMISSION.

cabochon cuts of the Middle Ages, during the Renaissance table cuts were common. With the renewal of classical traditions the art of cameo cutting was revived and northern Italy was an important source for this form of lapidary arts.

In the second half of the seventeenth century while Spain was in decline, France became the most important economic and cultural center. All luxury industries flourished in the France of Louis XIV. French silks from Lyon and dress fashions were exported and, with these, styles for jewelry. It was also a period when women were playing an increasingly significant role in society. For their dress, heavyweight brocades had been replaced by light silks in various pastel shades. The splendor and bright colors of the fabrics required a decrease of color in jewelry. Portraits of the period illustrate a passion for pearls, strung as necklaces or worn as pearl drops suspended from earrings, or from brooches worn on the breast, sleeve, or in the hair. Pearls were very valuable, and while pearls often were ostentatiously displayed, it is likely



**Papua New Guinea native.** In some parts of the world, natural and unaltered materials such as shells, feathers, and the teeth, horns, and claws of animals are worn as jewelry. © WOLFGANG KAEHLER/CORBIS. REPRODUCED BY PERMISSION.

that most of them were fake; fake pearls are known to have been produced since about 1400. Diamonds were favored. French-style enamelled settings and decorations were equally subdued in their color scheme: opaque white enamel was outlined with black, and pale pink or turquoise enamel was applied as highlights of the decoration. A source for the naturalistic floral designs of enamel decorations was the study of botany, a new science. Jewelry had the tendency of being less figural and more decorative with bows and clusters of gemstones. However, the Thirty Years War that ravaged Europe between 1618 and 1648, as well as the plague, resulted in a new type of jewelry, *memento mori*. The wearer was reminded of his or her transience and mortality, and skull's heads and skeletons were featured in all types of jewelry, which lived on in mourning jewelry of the eighteenth and nineteenth centuries with funerary ornaments and weeping maidens as motifs.

Designs in jewelry were in general more playful by the eighteenth century and the grand elegant court style

of Louis XV of France was to influence the whole of Europe, even as far as Russia. The compositions of the jewelry were more naturalistic, and thus asymmetrical; flower sprays and baskets were gem-studded, as were feathers, ribbons, and bows. Eighteenth-century jewelry moved from monochrome to polychrome; metal foils placed under the gemstones enhanced their color. Indian diamond mines had been exhausted, but with new mines found by the Portuguese in Brazil the fashion continued, and by 1720 the rose-cut diamond had been developed, allowing more light reflections. Other fashionable stones were agates, mossagate, and marcasite. Pearl strands with ornate clasps were worn like chokers; large stomachers were attached to the narrow bodices, and aigrettes to the hair; and shoe buckles were also bejewelled. With the Industrial Revolution in its beginnings towards the end of the eighteenth century, new materials for jewelry had been discovered, including cut steel. This hard metal was faceted to look like diamonds. The industrialist, Josiah Wedgwood (1730–1795), the founder of Wedgwood pottery, designed porcelain cameos to be inserted into jewelry. A special formula for making glass paste was named after Georges Frédéric Strass (1701–1773). After Marie Antoinette of France wore strass at court, it became socially acceptable to wear paste jewelry, which would have shimmered splendidly in candlelight.

In 1789 the French Revolution had dramatic effects not only in the politics and life of France, but also on Europe as a whole. Outside France the market was flooded by the jewels and gemstones of those who managed to escape, and prices fell radically. In France anybody owning jewels of aristocratic origin faced death by guillotine; only jewelry made of base metals was permitted, and this jewelry had political and patriotic inscriptions or symbols.

Luxury was revived in France with Napoleon when he proclaimed his empire in 1804. His wife Josephine was a trend-setter and wore Greek fashion, which was reflected in jewelry. Cameos, the Greek key pattern, laurel wreaths, and filigree work were reminiscent of antiquity. However the Napoleonic Wars led to quite a different and innovative type of jewelry known as Berlin iron, first developed when ladies gave their golden jewelry to finance the wars and received iron jewelry in return. The fashion spread from Germany to Austria and France; the style of this jewelry was antique or Gothic, typical of the nineteenth century with its eclectic styles.

The effects of the Industrial Revolution and the rise of the middle class became particularly evident in Britain. The middle class imitated the jewelry of the aristocracy, but instead of diamonds, rubies, sapphires, and emeralds, gemstones such as amethyst, chrysoprase, tourmaline, turquoise, and many other colourful substitutes were applied. Seed pearls were labour intensive, but as an inexpensive material replaced opulent pearl jewelry. As in dress fashions, evening and day jewelry was differenti-



ated, the full parure consisting of necklace, bracelets, brooch, and earrings was intended for the evening, whereas the demi-parure, a brooch with matching earrings, for daytime wear. Sentimental jewelry was extremely popular: gifts with love or messages of friendship, and souvenirs of hair of the beloved or deceased were integrated in jewels. The newly acquired wealth of the middle class enabled travel, and souvenir jewelry was invented soon after, such as *pietra dura* work from Florence, coral from Naples, micromosaics from Rome, and the archaeological styles from Egypt, Assyria, and the Celtic lands. Not only were archaeological and exotic cultures reinterpreted, but so were the Middle Ages and Renaissance. By the second half of the nineteenth century the famous jewelry houses of today opened branches in the capital cities of Europe; jewelry became global.

The path to modernism in jewelry began around the turn of the twentieth century, during the *belle époque* when there was a mood for renewal and individually crafted luxury items. Paris with its exhibition of 1900 was predominant in the new aesthetic movement. The jewelry expressed emotions, and winged women were symbolic of emancipation; nature was metaphorically interpreted: themes such as birth, death, and rebirth were expressed through plants in varying stages of their life. René Lalique laid the foundation for artists' jewelry of the twentieth century and introduced novel material combinations, such as precious gold with non-precious glass. Diamonds were applied sparingly, *plique-à-jour* enamel allowed light to shine through, opals gave iridescence, and materials appeared to almost dematerialize. In contrast, silver with enamel and a few gemstones defined the Jugendstil in Germany and the Viennese Secession in Austria, both reducing nature to stylized geometric forms. Liberty of London chose Celtic inspirations, and Georg Jensen in Denmark a more sculptural rendering of nature. By 1910 platinum jewelry in the Louis XVI style with bows, tassels, and garlands enabled thin, almost invisible settings and linear designs. The costumes of the Ballets Russes in Paris were immensely inspirational for vivid color combinations in jewelry, such as emeralds with sapphires, turquoises, and coral.

Decisive innovations in jewelry were brutally interrupted by World War I. Many widows were obliged to gain employment to survive; dress and hair fashions became casual, and so did jewelry. In the golden twenties elegant lifestyle and lavish luxury prevailed again, mirrored in the jewels of the epoch. Diamonds and gemstones form stylized compositions in contrasting colors that are reminiscent of such art movements as Cubism, de Stijl and Futurism. The exoticism of Africa and Egypt attracted jewelers as well. Germany, struggling with political and economical concerns and following the artistic philosophies of the Bauhaus school of design, developed jewelry made of non-precious materials such as chrome-plated brass. Events such as the stock market crash on Wall Street in 1929 had a global economic effect in Europe, as

did World War II, when materials for jewelry were scarce, but the desire for jewelry never ceased.

In the aftermath of the wars in the twentieth century, jewelry experienced a departure from its traditional values due to radical changes in society: housewives could no longer afford staff, and young people learned to be self-sufficient. Like fashion, jewelry designs followed the movements of youth culture. Women became more independent, and began buying their own jewelry rather than traditionally having it given to them by their husbands as had been traditional. Never before had jewelry been so diverse and so independent of dress fashions.

In the 1950s and 1960s the desire for luxury was epitomized by Hollywood with its make-believe world, mink stoles, and diamonds galore. During this time jewelers in Europe were experimenting with gold surfaces, designing unconventional settings, and, thus, transforming jewelry into a free art form. After the 1960s jewelry took an almost revolutionary turn with the freelance artist jewelers in their studios boldly setting out on the path of the fine arts—by the 1980s they broke existing boundaries of dimensions and materials and used materials from gold to rubber to paper.

More than any other time in its history, by the early twenty-first century, jewelry reflected the wearers' moods and feelings, favorite colors, taste, understanding of the arts, and last, but not least, their individuality.

See also **Brooches and Pins; Earrings; Necklaces and Pendants; Rings.**

#### BIBLIOGRAPHY

- Andrews, Carol. *Ancient Egyptian Jewelry*. New York: Harry N. Abrams, 1991.
- Bury, Shirley. *Jewellery 1789–1910: The International Era*. 2 vols. Woodbridge, Suffolk, England: Antique Collectors' Club, 1991.
- Daniëls, Ger. *Folk Jewelry of the World*. New York: Rizzoli, 1989.
- Dorner, Peter, and Ralph Turner. *The New Jewelry: Trends and Traditions*. Revised edition. New York: Thames and Hudson, 1994.
- Lightbown, Ronald W. *Mediaeval European Jewellery: With a Catalogue of the Collection in the Victoria and Albert Museum*. London: Victoria and Albert Museum, 1992.
- Mack, John, ed. *Ethnic Jewelry*. New York: Abrams, 1988.
- Phillips, Clare. *Jewelry: From Antiquity to the Present*. New York: Thames and Hudson, 1996.
- Princely Magnificence: Court Jewels of the Renaissance, 1500–1630*. London: Victoria and Albert Museum, 1980. An exhibition catalog.
- Tait, Hugh, ed. *Seven Thousand Years of Jewellery*. London: British Museum Publications, 1986.
- Williams, Dyfri, and Jack Ogden. *Greek Gold: Jewelry of the Classical World*. New York: Abrams, 1994.

Anna Beatriz Chadour-Sampson

**JEWISH DRESS** Although no specific costume was ever mandated by Jewish law, and no universal Jewish costume ever evolved, certain dress codes have been clearly identified with the Jewish people throughout the ages. In addition to the influence of Jewish law and custom on the development of these dress codes, these codes were impacted by the geography and historical setting in which the costume developed, and the extent of integration in the wider, gentile community.

Several principal factors have determined Jewish dress throughout the ages:

1. Halachah: the whole legal system of Judaism which embraces all laws and observances, from the Bible henceforth, as well as codes of conduct and customs.
2. Restrictive decrees and edicts by non-Jewish authorities in countries where Jews lived, as well as Jewish inner-communal regulations.
3. Prevailing local sartorial styles and dress codes.

### Halachah

Halachah, the code of Jewish law, is based mainly on biblical precepts, which are considered the primary and most authoritative source for all Jewish laws. Since biblical precepts concerning dress are few, they determine only several aspects of Jewish costume. Later halakhic rulings regulated dress codes and interpreted the biblical injunctions.

The explicit biblical precepts refer to attaching fringes to men's dress and the prohibition of wearing a garment made of a mixture of wool and linen. Some rabbinical authorities and scholars deduce that the covering of women's hair and *peoth*—sidelocks (Leviticus 19:27) worn by Jews, which are today distinctive features of the Jewish male external appearance, were also biblical precepts. One should also mention the *tefillin*—philacteries: these are small leather boxes containing holy and protective texts which are attached to the forehead and the left arm during morning prayer (see Exodus 13:9, 16, and Deuteronomy 6:8; 11:18). Today these are ritual accessories to which utmost importance is attributed, but in Talmudic times some scholars wore them throughout the day.

**Tzitzith.** In biblical times, fringes were attached to outer garments, which were probably a kind of sheetlike wraps, which had four corners. In time, when dress styles changed, two separate ritual garments evolved to fulfill this precept. The *tallith*, the prayer shawl, is a rectangular fringed shawl worn for prayer and important events in the Jewish life cycle. The *tzitzith*, which literally means fringe, or *tallith katan* (literally "small tallith"), is a poncho-like undershirt worn at all times by orthodox Jewish men. According to the Torah, one tassel should be blue (Numbers 15:18), but as the process of production of the blue extracted from the *murex purpura* (a snail used for dyeing blue and purple in the Mediterranean) was lost, the fringes were usually white. The fringes consist of four

cords folded to produce eight ends, knotted in differing numerical combinations, equivalent to the numerical value of the letters of names of God. The religious, mystic-symbolic meaning attributed to these garments imbued them also with protective and magical powers.

**Sha'atnez.** Because it is not outwardly visible, *sha'atnez*, though kept to this day by certain observant Jews, is not a distinctive mark of Jewish dress. With mass-produced clothing, special laboratories are required to determine whether a particular garment contains the forbidden mixture. In the past, in many communities, tailoring became a prevalent Jewish occupation in order to be able to control the combination of fibers and textiles of clothes.

Two major tendencies direct halakhic rulings concerning dress. One is segregation from the gentile environment: "Nor shall you follow their laws" (Leviticus 18:3), as is stated generally in the Bible. More specifically relating to dress, Maimonides, the renowned medieval Jewish scholar, stated: "One must not follow in the ways of those who worship the stars nor imitate them either in dress or hairstyle" (*Mishneh Thorah, Hilkhos Avodas Kokhavim* 11:1).

### Modesty

Another major concern of halakhic rulings regarding dress are various issues of modesty—for instance, the requirement to be decently dressed and covered during prayer (Tosefta Brachot 2:14, second century C.E.). This attitude was later interpreted as the separation between the upper part of the body, considered spiritual and pure, from the lower part, considered mundane and impure. Among the Hasidim of Eastern Europe (from the eighteenth century on) this division of the body acquired a rich symbolical meaning and is fulfilled by the *gartle*, a belt donned ritually before prayer.

The equivalent item among women was the apron, the purpose of which was to cover and protect their reproductive organs. These aprons, worn either under or above the skirt or both, were considered a symbol of modesty and magically protective. The wearing of aprons persisted among Eastern European Jewish women and after having almost vanished, made a comeback among some of the ultraorthodox women who wear them while lighting Shabbat candles and during festive occasions. They regard them as charms that will bring them well-mannered children.

**Head covering for women.** The practice of women covering their heads became pervasive and universal throughout the Jewish world. In some communities, it became customary to cut the hair or even shave it shortly before or after the wedding. Some women attempt to leave no hair uncovered while others allow some parts to be seen as is customary in each community. The custom of wearing *sheytls*, wigs, was adapted by Jewish women in Europe in the sixteenth century, when it was fashionable for both

men and women, and it has lasted as an option for head covering among some Jewish orthodox groups into the twenty-first century. In several places in Morocco, in Bukhara and Georgia, Jewish women's coifs incorporated false hair that served as partial wigs. Such is the elaborate *mabdour* headgear of the Jewish women of the Sous region on the southern coast of Morocco. This is an intricate work of silver interwoven with the hair of a horse's tail, two locks of which frame the woman's forehead.

The wearing of wigs even in the twenty-first century is a highly controversial issue among the different orthodox groups. Some claim that the display of hair, even false hair, does not abide with the prohibition to conceal it, since the showing of any hair is considered erotic, and therefore immodest.

With the passing of time, both the manner and style of the head covering have taken many forms and differ immensely from place to place. In the past, prior to modernization, women's head covering attested both to her marital status as well as to her socio-economic status, her place of residence, and communal affiliation. In Sana'a, Yemenite Jewish women wore the distinctive *gargush*, a hoodlike headgear that concealed the hair, the forehead, and the neck. It identified the Jewish woman from the Muslim woman and the Jewish woman of San'a from Jewish women of other localities. Every woman had several hoods, the most sumptuous was the *gargush mezabhar merassaf* (the full golden hood), decorated with gilt, silver filigree pieces, and with several coins. All these riches formed part of the woman's dowry, which she received from her father and were used as her cash reserve.

In the early twenty-first century the distinction is less geographic and attests to religious group affiliation and degree of religiosity. Szatmar Hasidic women in New York and Jerusalem wear similar head coverings—a scarf covering their hair entirely, sometimes with a padding under it or a small piece of synthetic wig in front, or a synthetic wig worn under the scarf.

The women of the Neturei Karta, and the most extreme groups, shave their hair, and cover their head with a tight black scarf. Whereas the Belz Hasidic women wear a wig and a small cap on top of it, Sephardi-Oriental women in Israel do not wear wigs but fashionable hats and scarves.

**Head covering for men.** Unlike women's hair covering, men's head covering has only become obligatory in the last centuries. It is not mentioned in the Torah, and in the Babylonian Talmud it is only a custom practiced by certain people—Torah scholars—and at certain times, such as during prayers and benedictions. It is conceived as a sign of religious submission and respect to higher authorities and before God.

In the sixteenth century, when the Shulhan Aruch, the Code of Jewish Law, was written and accepted by all Jewish communities, men's head covering was not yet uni-



**Hasidic boy wearing phylacteries.** Small leather boxes called *tefillin*, phylacteries, are worn on the forehead and left arm during prayer. The boxes contain holy texts. © RICHARD T. NOWITZ/CORBIS. REPRODUCED BY PERMISSION.

versal or compulsory. The code stated that covering the head was a sign of a God-fearing Jew and especially important during study and prayer (*Orakh kbayyim* 2,2; 151.6). In Christian countries, the Jewish covering of the head in the synagogue evolved as contrary to the practice of uncovering one's head as a sign of reverence, while in the Muslim world, Jews were no exception to the general practice of covering their heads. In both Christian and Muslim lands, Jews were required to wear a hat, the shape and color of which would serve to identify them as Jews.

Well known in its time was the *Judenhut*, the medieval pointed Jewish hat by which Jews were identified, and which are clearly seen in both Jewish and Christian depictions of Jewish life. The wearing of a double head covering—a *kippab* or yarmulke (skullcap) and hat—among the ultraorthodox, or a skullcap only, by orthodox Jews, evolved in nineteenth-century Europe and became part of the controversy between reformists and traditionalist groups. Among some of the reformists, the skullcap is worn during prayer and other ceremonial occasions. As for the ultraorthodox, in order to express their opposition to the reform, they started to wear a skullcap and a hat on top of it. In the early twenty-first century, especially in Israeli society, covering of the head or not





**Jewish father and sons at prayer.** During prayer, rectangular fringed shawls, or *talliths*, are worn. Some Orthodox Jews also wear small fringed talliths under their clothing at all times. ©

DAVID H. WELLS/CORBIS. REPRODUCED BY PERMISSION.

distinguishes between secular and observant Jews. The type of covering indicates socio-religious and ideological, even political affiliation. For instance the *kippah sru-gab*, a crocheted skullcap, has become an identity mark of the National Religious community and political party.

### Restrictive Decrees and Edicts

Apart from the inner Halakhic rules, Jewish costume was determined by restrictive decrees issued by the gentile authorities in the countries in which Jews lived in the diaspora. These laws required Jews to wear special garment items, prohibited them from wearing particular fabrics and colors, and obliged them to mark their dress with badges.

In Muslim lands, the edicts began with the Laws of Omar (in the eighth century) that required that all non-Muslims be distinguished by their external appearance, by their clothing, the external manifestation of their lower legal status as “infidels.” This distinction had far-reaching legal and social implications, and it served as a tool for keeping ethno-religious hierarchies and boundaries. These laws were the conceptual guidelines for practical restrictions imposed by different rulers. The decrees

did not deal with entire outfits, but pertained mainly to the colors and quality of fabrics, and sometimes to particular components of dress such as head gear or footwear. In Bukhara, the Jews had to wear ropelike belts as a distinction mark.

Infidels were supposed to wear dark colors such as black or dark blue (some places had specific colors for Jews and others for Christians). Green was reserved for Muslims because it is the holy color of Islam. Jews were not allowed to use luxurious fabrics, as were enumerated in the edicts. There were restrictions pertaining to the cut and size of the garment. In Turkey, the size of the turban was of great significance—the larger the turban, the higher the rank of its wearer—thus the edicts restricted the length of the turban fabric and the width of the cloak permitted to Jews. In Afghanistan in the first half of the twentieth century, Jewish men could only wear gray turbans.

Similar restrictions were imposed in medieval Europe by the church councils. In 1215, the Lateran Council issued the well-known dress restriction as a reaction to the forbidden mingling of Christians with Jews and Muslims:

... [T]hey may not ... resort to excusing themselves ... for the excesses of such accursed intercourse, we decree that such [Jews and Saracens] ... in every Christian province and at all times shall be distinguished in the eyes of the public from other peoples by the character of their dress. (Rubens, 1973, p. 81)

These decrees also included the wearing of a badge. The badge differed in shape and color as well as in the place where it should be displayed, either on the right shoulder or on the hat. In the duchies of Italy, a yellow patch was worn. In England, its shape was of the Tablets of the Law, and in Germany, the badge was a ring-shaped sign. The Jews were also obliged to purchase these badges from the government. “Every Jew above the age of seven must wear a yellow or red and white badge. The royal tax collectors will collect the fee for the purchase of the badge” (France, 1217–1284).

These edicts and restrictions were intended to mark the Jewish population and set them apart from others, thereby aiming at degrading and humiliating them. The spirit of this distinction did not disappear altogether and was revived by Nazi Germany by imposing the yellow badge as a race discriminator. The reaction of the Jewish population to these laws took different forms. In many cases, as can be expected, it was resented, but in some instances, it was accepted positively as described by a traveler to the Ottoman empire in the seventeenth century: “As in religion they differ from others so they do in habit: in Christendom enforcedly, here in the Turkie voluntarily” (Sandys, p. 115).

Though this may not be accurate, it does acknowledge different reactions to the humiliating restrictions. These differentiating restrictions were accepted posi-

tively, as they met with the Halakha and the desire to differentiate themselves from others by their clothing. In some cases, these restrictions were given different explanations and an inner symbolic interpretation. For example, Moroccan and Tunisian Jews and the Jews of Sana'a in Yemen held that the wearing of black, adapted by the Jews themselves, was considered as a sign of mourning commemorating the destruction of the Temple. (There are several other signs commemorating the destruction that, according to Jewish law, one has to keep).

These restrictions were at times corroborated by inner communal regulations and sumptuary laws called *takkanot*. These regulations issued by Jewish communities referred mainly to women's attire, instructing them to refrain from wearing luxurious clothes—especially with gold decorations and opulent jewelry—mainly in the public domain. Their purposes were twofold: the first, to avoid arousing jealousy among non-Jews, as it was feared that excess finery in Jewish dress might bring about additional edicts by the authorities; the second, to avoid internal tensions between rich and poor families within Jewish communities. These regulations limited excessive finery in weddings and other festive occasions but allowed some exceptions.

Such rules and regulations provide very important historical sources for a meticulous study of dress codes in each community.

We have unanimously decided that from this day forward ... no woman, young or old, shall wear arm bracelets, or chains, or gold bracelets, or gold hoops, or gold rings, or any gold ornament ... or pearl necklaces, or nose rings ... [A woman] cannot wear any garment made of wool or silk, and [she] certainly [cannot wear] gold or silver embroidery, even if the lining is inside out, except for a head covering, which is all she is allowed to wear ... and as for children and infants, neither boys nor girls may [dress] themselves [in articles made] either of gold or of silver or of silk. (From regulations pronounced by the rabbis of the community of Fez, Morocco, 1613)

Velvet for dresses, even for linings, is forbidden to women and girls, with the exception of black velvet. The bride may wear any kind of velvet under the canopy during her wedding ... any type of skirt which is stiffened with a hoop of wire or ... other devices is forbidden to married and single women ... even small children. ... From today until further notice, no silk dresses of two colors should be made for women, with the exception of dark grey and brown. (Fine: 20 thalers). Whoever offends openly or in secret will be excommunicated and treated as someone who has sinned against God. (From the Jewish regulations for clothing and weddings, Hamburg, Germany, 1715)

### Sartorial Styles and Dress Codes

The great variety of Jewish traditional attire prior to modernization, attests to the marked influence of the surrounding culture on each Jewish community. One can



**Sephardic Jews in skull caps.** Covering of the head became mandatory for most orthodox Jews after publication of the *Code of Jewish Law* in the sixteenth century. © ALEN MACWEENEY/CORBIS. REPRODUCED BY PERMISSION.

safely say that the attire of the Jews resembled more that of their surrounding culture than that of Jews living in other places, notwithstanding the distinction marks imposed on them.

Yet costume was not only conceived as marking ethno-religious boundaries, but also as defining group identity within the Jewish communities; one example is the “great dress,” worn as a bridal and festive dress by urban Spanish Jewish women (descendants of the Jews expelled from Spain in 1492) in Morocco. This sumptuous outfit made of metal thread-embroidered velvet, was strikingly different from the local Muslim costumes. It strongly resembled Spanish costume of the sixteenth century and preserved many of its stylistic traits. In Morocco, this dress became an identity mark of the urban Spanish Jews vis-à-vis the local rural Jews; it was one of the symbols of the preservation of the Spanish heritage, which was a source of pride to this group. However, it is not certain that this dress was worn by Jews in Spain. Within Morocco, there were also variations of this dress each belonging to a certain town, Fez, Rabat, Mogador, and others.

This rare example of the preservation of sartorial styles by an immigrant group for over 400 years leads to another feature thought to be typical or recurring in Jewish costume in different places. It has been observed that

Jews in many communities had a tendency to retain dress styles long after they have been abandoned by the gentile society. After some time, these anachronistic clothes or items of dress were appropriated by the Jews and considered later to be exclusive to them and even an identifying trait. The best known example of this phenomenon is the Hassidic or ultraorthodox costume, derived from the Polish eighteenth-century dress of nobleman and appropriated and preserved by the Jews, which became a distinctive attire exclusive to them. Another example is the sheetlike wrap-and-veil street wear worn by Jewish women in Baghdad until 1952. The custom of veiling was a norm in Muslim society. Jewish women adhered to that norm. Veiling was the prerogative of Muslim women and was not imposed on low-status women such as servants and non-Muslims. Non-Muslim women are not required to veil themselves. The Bagdadi wrap covered the whole body, while the face was hidden by a square black veil. In this period, Bagdadi Jewish women's *izar*, veils, were made of pastel-colored silk interwoven with metal thread. Prevalent among Muslim women in former times, such dress came to be considered a distinctively Jewish outfit in the early twentieth century when the customary Muslim attire changed to a plain black wrap.

The conflict between the will to integrate and the will to isolate Jewish society from the gentile surrounding cultures was strongest in Europe in the period of emancipation and modernization during the nineteenth century. As European society enabled the Jews to become equal citizens, some of the Jews wanted to assimilate and not to be distinguished by their dress, while others saw this assimilation as a great danger to Jewish religion and culture. The reform Jews changed their traditional garb to fashionable modern costume. This change was accompanied by debates over head covering and other matters. These changes and reforms caused a strong reaction among some of the East European Jews centered in Hungary, who preached to cling more strongly to tradition. Every domain of life and dress was considered a central aspect of this tradition (under the *balachic* precept that anything new is forbidden by the Torah).

The wearing of better clinging traditional attire down to the minutest detail has turned the dress of the ultraorthodox Jews into a kind of uniform by which they are recognized. It is also considered a protective mechanism against sin.

Since there are few common features of Jewish costume across time and place, it is fundamental to study it in relation to surrounding historical and cultural setting. Yet, in the confines of a given society and the bounds of limited time, Jews could still be identified by certain particularities of their dress, which were often a combination of local dress with one or two sartorial elements that they carried with them throughout time.

See also **Religion and Dress**.

#### BIBLIOGRAPHY

- Bar'am, Ben Yossef No'am. *Brides and Betrothals: Jewish Wedding Rituals in Afghanistan*. Jerusalem: The Israel Museum, 1998.
- Carrel, Goldman Barbara. "Women's Head-Coverings: A Feminised System of Hasidic Distinction." In *Religion and Dress and the Body*. Edited by Linda Boynton Arthur. Oxford: Berg, 1999, pp. 163–180.
- Frankel, Giza. "Notes on the Costume of the Jewish Woman in Eastern Europe." *Journal of Jewish Art* 7 (1980): 50–57.
- Goitein, Shlomo Dov. *A Mediterranean Society*. Berkeley: University of California Press, 1983, pp. 150–200.
- Juhasz, Esther. *Sephardi Jews in the Ottoman Empire: Aspects of Material Culture*. Jerusalem: The Israel Museum, 1989.
- Krauss, Samuel. "The Jewish Rite of Covering the Head." In *Beauty in Holiness*. Edited by Joseph Gutman. Hebrew Union College Annual XIX, 1946. Reprint, Hoboken, N.J.: Katv Publishing, 1970, pp. 420–467.
- Muller-Lancet, Aviva. "Jewish Ethnographic Costume." In *Encyclopedia of Jewish History*. Israel: Masada, 1986.
- . *La vie juive au Maroc*. Jerusalem: The Israel Museum, 1973.
- Rubens, Alfred. *A History of Jewish Costume*. London: Weidenfeld and Nicolson, 1967, 1973.
- Sandys, George. *Travels Containing an History of the Original and Present State of the Turkish Empire*. London: Rob. Clavell, 1673.
- Schwartz-Be'eri, Ora. *The Jews of Kurdistan: Daily Life, Customs, Arts and Crafts*. Jerusalem: The Israel Museum, 2000.
- Slapak, Orpa, ed. *The Jews of India: A Story of Three Communities*. Jerusalem: The Israel Museum, 1995.
- Stillman, Yedida K. "The Costume of the Moroccan Jewish Woman." In *Studies in Jewish Folklore*. Edited by F. Talmage. Cambridge, Mass.: Association for Jewish Studies, 1981.

Orpa Slapak and Esther Juhasz

**JILBAB** A plain, ankle-length garment or set of garments, the *jilbab* is worn by Muslim women in many different countries for reasons that include modesty, religious devotion, and political activism. Several other words, including *jellabib* and *djellaba*, refer to the same or similar styles of dress. The *djellaba*, a long cloak with a hood, is worn in North Africa by both men and women. In Palestine, Jordan, and Syria, the *jilbab* is a long overcoat that buttons down the front and is worn with a headscarf called a *khimar*. In Southeast Asia and East Africa, the terms *jellabib* and *jilbab* refer to a set of simple, opaque garments that, except for the face and hands, cover the body from head to toe. This new style of Muslim dress is intended as a specific change from garments (such as a sarong or *garbasaar*, a traditional head and body covering) that are part of local culture. The *jilbab* has diffused from the Middle East in conjunction with the rise of Islamism (political Islam) following the Iranian Revolution



in 1979. It is also connected with more recent efforts to counteract some of the perceived negative effects of globalization such as materialism and the corruption of secular governments.

### Meanings

Along with *khimar* (a head covering) and *hijab* (a more general word for something that covers), *jilbab* is a special term because it appears directly in the Qur'an. Verse (33:59) briefly describes how the wives of the prophet Muhammad (and by extension, Muslim women) should be dressed: "O Prophet! Tell thy wives and thy daughters and the women of the believers to draw their cloaks [*jilbab*] round them [when they go abroad]. That will be better, so that they may be recognized and not annoyed" (Pickthall p. 449). This passage highlights several reasons for renewed interest in the *jilbab*. As more Muslims than ever have come into contact with non-Muslims or taken up residence in non-Muslim countries, many have wanted to make their status visible "so that they may be recognized." The *jilbab* marks a devout woman's need to pray regularly, to abstain from pork and alcohol, and to avoid compromising situations with unrelated men. For Islamist purposes, the *jilbab* speaks to an interest in "pure" Islam as exemplified by the prophet Muhammad. This is part of a pan-Islamic effort to find common ground between different sects and cultures in the Muslim world.

### Construction

Although the Qur'an does not specify the color, texture, or shape of the *jilbab*, a few basic styles have become commonplace and in the early 2000s are viewed as "authentic" dress for Muslim women. In the United States and parts of Europe, the *jilbab* is easily recognized as "religious dress" because it resembles the style of clothing worn by nuns before Vatican II. Some corporations, in an effort to comply with antidiscrimination laws, have adapted the *jilbab* as a Muslim version of their standard uniform.

Patterns for women who want to make their own Islamic clothing are widely available in books and even on the Internet. Somali women living in the United States, Europe, and Australia frequently commission or sew their own *jilbab* using cloth from local fabric stores. This requires at least four yards of material. Two yards are used for a skirt and the rest for a two-piece, tailored head covering that fits closely around the neck and hairline. Older and more devout women often prefer to have a longer head covering that extends to the waistline or even mid-calf. (This requires more fabric.) As an alternative, some women wear the button-down overcoat called *jilbab* in Jordan and Palestine. This garment has a longer history in Somali culture and is called "shuka," a word for something that conceals the body.

In Iran, women often construct these garments from heavy black, navy blue, or gray fabrics. As Faegheh Shi-



"In June 1992, when a delegation of twenty-two Islamist women . . . visited Baku, Azerbaijan, their heavily-covered figures in chadors in Baku's hot summer brought stares and disdainful reactions everywhere they went. They met with the same reaction in Tajikistan and the rest of Central Asia during visits in the early 1990s. On one occasion, a middle-aged Azeri woman asked me to translate a question. . . . "Don't you feel hot under this heavy black garment in this hot summer? . . ." "But the fire in hell is much hotter if one fails to follow Allah's orders," one of the Iranians replied. Baffled by her response, the Azeri woman mumbled, "What a cruel God you have! The Allah of Islam that I know of is much kinder to women" (Tohidi, p. 20)

razi notes in *Undressing Religion*, "Black, being a sign of mourning, carries a symbolic meaning in tune with the cause of the Revolution, the Iran/Iraq war and . . . those who lost their lives as martyrs [in the cause of establishing an Islamic state]" (p. 120). Women in other countries wear the *jilbab* in a variety of muted colors—white (for prayers), brown, green, and rose. Somali dress in the 1970s and 1980s was very colorful, and Somali women in the early 2000s sometimes wear the *jilbab* in brighter colors such as yellow, mint green, and magenta. They might also combine the plain *jilbab* with a few touches of more colorful printed fabrics at the hemline or on a scarf worn just underneath the tailored head covering.

### The Spread of Islamism

For many women, the decision to wear the *jilbab* is based on their own personal beliefs and convictions. At the same time, these garments are part of a global dialogue concerning how Muslims should live in the contemporary world. The Iranian Revolution of 1979 was an early success of Islamism, a movement to create social, economic, and political change through Islam and to establish new systems of power based on Islamic law. In the 1980s, Iranian activists who believed in Islamic dress as a symbol of this transformation traveled to parts of Central Asia, North Africa, the Persian Gulf, and Turkey to promote their ideas. The *jilbab* worn in Syria, Jordan, and Palestine is called "rupush-rusari" in Iran. There were limits to their success, however. In her essay in *Iran and the Surrounding World*, Nayereh Tohidi notes there were differences in language (Persian vs. Arabic), religious practices (Shi'a vs. Sunnī), and a general dislike for restrictive styles of dress based on the chador.

Since that time, ideas about these styles of dress have spread more indirectly through religious books and pamphlets, videos, television programs, and the Internet. In

the United States and Europe, Muslims from many different countries have been brought together to worship in neighborhood mosques.

See also **Djellaba; Islamic Dress, Contemporary.**

#### BIBLIOGRAPHY

- Arthur, Linda, ed. *Undressing Religion: Commitment and Conversion from a Cross-Cultural Perspective*. Oxford: Berg, 2000.
- Berns McGown, Rima. *Muslims in the Diaspora: The Somali Communities of London and Toronto*. Toronto: University of Toronto Press, 1999.
- El Guindi, Fadwa. *Veil: Modesty, Privacy and Resistance*. Oxford: Berg, 1999.
- Keddie, Nikki R., and Rudi Matthi, eds. *Iran and the Surrounding World: Interactions in Culture and Cultural Politics*. Seattle: University of Washington Press, 2002.
- Pickthall, Muhammad Marmaduke. *The Meaning of the Glorious Koran: Text and Explanatory Translation*. Mecca: Muslim World League, 1977.
- Tohidi, Nayereh. "The International Connections of the Women's Movement in Iran." In *Islam and the Surrounding World*. Edited by Nikki R. Keddie and Rudi Matthi. Seattle: University of Washington Press, 2002.

Heather Marie Akou

**JILLABA.** See **Djellaba.**

**JOCKEY SHORTS** The display of Jockey shorts in the window of Marshall Field's department store in Chicago on 19 January 1935 revolutionized the men's underwear market. Over the following three months, thirty thousand were sold, and Jockey began "Changing the Underwear Habits of the Nation."

The Jockey short's Y-front with overlapping fly was patented by Coopers Inc. in 1934. Unlike other underwear of the time, it provided men with "masculine support," then only available by wearing an athletic supporter or jockstrap. In order to reinforce the idea that this new underwear would provide support, it was discreetly called the Jockey (JOCK-ey). Advertising played a key role in the awareness and massive sales of jockey shorts, and an underwear-clad Jockey statue was used both in window displays and stores. The success of the Jockey short and its massive brand recognition led the company to change its name from Coopers Inc. to Jockey.

Until the advent of Jockey Y-fronts in 1934, men's underwear consisted of loose shirts, singlets, long johns, and drawers that revealed little of the body's form. Y-fronts were revolutionary in that, owing to the way the fly was angled for modesty when urinating in public, the seams drew attention to the male genitals.

Jockey shorts, however, were not the first revolutionary underwear idea that the company had introduced. In 1910, S. T. Coopers and Sons, as the company was then known, developed one of the first closed-crotch union suits. The "Kenosha Klosed Krotch" had a seat design of two pieces of fabric that overlapped in an X to allow access for hygienic purposes and it required no buttons or ties. This new underwear made history in 1911 after the oil paintings of men in their Kenosha Klosed Krotches by *Saturday Evening Post* artist J. C. Leyendecker became the first national print advertisements for men's underwear.

Brief-style underwear quickly caught on, and many other underwear manufacturers began to produce their version of the jockey short. Traditionally these shorts had been made of white cotton, but variety was introduced in the 1950s when manufacturers began to experiment with new man-made fibers such as rayon, Dacron, and Du Pont nylon.

However, it was not until after the menswear revolution of the 1960s, spearheaded by the boutiques in London's Carnaby Street, that colored and patterned briefs and Y-fronts became popular. The increasing popularity of tight trousers in men's fashion led to an increased demand for brief underwear that did not wrinkle under trousers. Skimpier brightly colored briefs began to be produced by the major underwear companies and were overtly promoted for their erotic connotations. Magazine advertisements of the 1970s marketed underwear as a means of sexualizing the body to attract members of the opposite sex.

In 1982, Calvin Klein used an enormous billboard in New York City's Times Square to advertise his men's white briefs. It was an overtly sexual image of a perfectly formed muscular man wearing nothing but white underwear. "Klein's billboard has been credited with heralding a new era in the imagery of men in advertising and with precipitating a new fashion in men's underwear" (Cole, p. 136).

By 2004, major designers had established underwear lines, ranging from thongs to briefs to boxer shorts. Traditional companies like Jockey reacted to the competition by producing new styles and "rebranding," marketing themselves using the now almost-clichéd images of muscular, hairless models in immaculate and revealing white jockey shorts.

See also **Boxer Shorts; Underwear.**

#### BIBLIOGRAPHY

- Carter, Alison. *Underwear: The Fashion History*. London: Batsford, 1992.
- Cole, Shaun. *Don We Now Our Gay Apparel: Gay Men's Dress in the Twentieth Century*. Oxford: Berg, 2000.
- Craik, Jennifer. *The Face of Fashion: Cultural Studies in Fashion*. London: Routledge 1994.

Griffin, Gary M. *The History of Men's Underwear: From Union Suits to Bikini Briefs*. Los Angeles: Added Dimensions Publishing, 1991.

Shaun Cole

**JUMPER.** See **Sweater.**

**JUMPER DRESS** As an item of dress, the word “jumper” has referred to various garments at different points in history and in diverse sectors of society. For example, in the United States, a jumper has been a loose jacket, a sailor’s overshirt, or middy blouse, a child’s garment or coverall with straight-legged pants, a hooded fur jacket, or a sleeveless one-piece dress usually worn over some type of upper garment. A British jumper is a pullover sweater, and the British refer to a U.S. jumper as a pinafore dress, a pinafore, or a “pinny.”

In mid- to late twentieth-century American English, a jumper is a woman’s or girl’s one-piece, sleeveless, dress-length garment with a low round, V, or square neckline designed to wear over a blouse, sweater, or shirt. Specific styles are described by adjectives such as “bib jumper,” styled with a biblike front inspired by bib overalls, or “horseshoe jumper” referring to the low horseshoe neckline in front and back.

The origin of the word is unclear especially since “jumper” refers to many different garments. It may have come from mid-nineteenth-century English dialect “jump,” meaning short coat; from Old French *juppe*, or Modern French *jupe*, meaning skirt; from Spanish *aljuba*, a Moorish garment; from Arabic *jubba*, a long garment with wide open sleeves, or *jabba*, to cut.

The evolution of the garment is also unclear. Historically, the jumper may have evolved from the fourteenth-century woman’s sideless *surcote* that was worn over a gown with tight-fitting long sleeves. The sideless *surcote* had a low neckline, giving the illusion of shoulder straps and deep oval armholes extending to the hips, so the tunic worn beneath could be seen. By the early fifteenth century, when other styles replaced it, the sideless gown identified the wearer as a French queen or princess.

References to jumpers in the early twentieth century often meant a two-piece dress with a long middy-style top designed for sports, a dramatic change in sportswear for women. Jean Patou, Paul Poiret, and Coco Chanel were leaders in replacing cumbersome garments with practical and convenient clothing for sports. Patou dressed Suzanne Lenglen, the 1920s champion tennis

player, in his hallmark short skirts and sleeveless long-waisted jumper blouses. Her athletic youthfulness captured the imagination of the fashion conscious (Lee-Potter), although it is unknown if this look was a predecessor to the American jumper.

While the jumper has not been at the forefront of fashion, its form has followed fashionable silhouettes such as the body skimming chemise or an exaggerated A-line resembling a tent or trapeze shapes in the 1960s. Jumpers seemed to evolve from function; and sportswear, separates, and layering are all concepts that apply to jumpers. Some jumper styles are reminiscent of children’s garments or school uniforms. The ideal body for women in the 1920s was straight, undeveloped, even childlike. The *garçonne*, or waif, look also was popular in the 1960s and again in the 1980s with many images of young women wearing short, mini-length jumpers. Functional, apron-like wraparound jumpers designed to protect clothing may have inspired Claire McCardell’s 1940s denim wrap-around coverall “popover dress.” McCardell was famous for her sportswear designs, including jumpers to wear over jersey leotards. Bonnie Cashin is another designer also known for designing jumpers as versatile and sophisticated sportswear.

See also **Cashin, Bonnie; McCardell, Claire; Sportswear.**

#### BIBLIOGRAPHY

- American Heritage Dictionary of the English Language*. 4th ed. Boston: Houghton Mifflin, 2000.
- Blair, Joanne. *Fashion Terminology*. Englewood Cliffs, N.J.: Prentice-Hall, Inc., 1992.
- Boucher, François. *20,000 Years of Fashion*. New York: Harry N. Abrams, 1987.
- Calasibetta, Charlotte, and Phyllis Tortora. *The Fairchild Dictionary of Fashion*. 3rd ed. New York: Fairchild Publications, Inc., 2003.
- Craig, Hazel T. *Clothing: A Comprehensive Study*. Philadelphia: J. B. Lippincott Company, 1968.
- Etherington-Smith, Meredith. *Patou*. London: Hutchinson, 1983.
- Lee-Potter, Charlie. *Sportswear in Vogue since 1910*. New York: Abbeville Press, 1984.
- Kirkland, Sally. “McCardell.” In *American Fashion*. Edited by Sarah Tomerlin Lee. New York: Quadrangle/The New York Times Book Company, 1975.
- Tortora, Phyllis, and Keith Eubank. *Survey of Historic Costume*. 3rd ed. New York: Fairchild Publications, 2000.
- Yohannan, Kohle, and Nancy Nolf. *Claire McCardell: Redefining Modernism*. New York: Harry N. Abrams, 1998.

Barbara Perso Heinemann





**KAFFIYEH** *Kaffiyeh* is used to refer to a large square head cloth, or a long rectangular head cloth, or neck scarf worn by men in the Arab world. The same term is used to refer to checkered red and white or black and white head cloths and to plain white ones. In Arabian societies all three colors are used: plain white, checkered red, and checkered black. On top of the kaffiyeh men place a band or circlet of twisted black cord made of silk or cotton thread known as *agal* (spoken Arabic for 'uqal).

Headgear for men in the Arab and Islamic East is variable in form, use, and terminology. Arab men of all persuasions and faiths distinctively covered their heads long before Islam. It is safe to distinguish three broad kinds of head cover for men: traditional secular, religious (Islamic or Christian), and revolutionary or resistance. These kinds not only refer to differences in form and appearance but also in function and meaning.

Historically in the region, there was as much head cover politics concerning men as concerning women. Turkey, after the fall of the Ottoman regime and the creation of a republican government, issued sartorial measures prohibiting traditional male headgear and encouraging Western hats. After the various revolutions in the Arab world in the 1950s and 1960s, particularly the 1952 Egyptian revolution led by Gamel Abdel-Nasser, the *fez* (*tarboush*) worn by men of the urban middle and upper classes, which had entered sartorial traditions with the reign of the Ottomans and remained, fell from favor. The *fez* became a symbol of classist, colonial interventionist messages which the antiroyal coups and revolutions were keen on removing. Many men who removed the *fez* went bareheaded permanently after that.

In the 1970s, when the Islamic movement began, urban middle-class men and college students who had until then been wearing jeans and slacks to college and work, began to wear a *gallabiyya* (*jellabib*) and a white kaffiyeh (pronounced *kufiyyah* in Egyptian Arabic). This new appearance marked a revitalization of Islamic identity and a desired return to forms of appearance that were innovatively envisioned, particularly by male and female college youth in urban Egypt, as reproducing historically Islamic clothing. The movement continues to this day and has spread throughout the Arab world.

The checkered kaffiyeh became internationally visible after the 1970s as a symbol of Palestine. Many people, especially students, around the world, including in Europe and the United States, showed their support for the Palestinian cause by wearing checkered kaffiyehs as neck scarves, which evoke images of Palestinian youth. The president of the Palestinian authority, Palestinian Liberation Organization (PLO), Yasir Arafat, always wears military fatigues with a checkered kaffiyeh as head cover, with a triangular fold at the center above mid-forehead. This fold is characteristic of the Palestinian style of wearing the kaffiyeh and can be seen also in Syria, Arabia, and the Gulf.

The style of solid long rectangular white kaffiyeh worn flat on the head and hanging down on both sides of the head, tends to be worn by pious Muslims or those in religious leadership positions. Seen throughout the Arab world, this style of wearing the kaffiyeh is understood as a symbol of commitment to religious values. The king of Jordan and his Hashemite royal men typically wear a kaffiyeh and *agal*. This communicates the king's identity as belonging to a long line of Hashemite bedouins indigenous to the region.

Like the "veil" or women's head cover, the kaffiyeh is not a fixed or static object of clothing. It can be manipulated to cover head or face. Thus a religious man may use the white kaffiyeh worn on his head to cover part of his face, including mouth and nose, in certain situations that need a symbolic separation in space, such as gender separation. Similarly, Muslim women in India, for example, manipulate their head covers to partially cover their faces in situations in which men who are their in-laws are nearby. In the case of Muslim Indian women, manipulating the head cover to partially veil the face communicates affinal kinship distance, whereas a Muslim man manipulating a head cover to partially veil his face communicates gender separation in public space.

Superficially resembling the kaffiyeh, the *'imama* (turban) is another kind of male headgear worn differently and is made of a much longer piece of cloth (118 inches, or 3 meters, or longer) wrapped around on top of one's head a number of times. It is predominantly white today, but a black *'imama* was worn by male members of the newly formed Islamic community in the seventh century in Arabia. This marker of male Arab identity that goes back before Islam, continues into the early 2000s.



**Jordanian man in kaffiyeh.** The *kaffiyeh* experienced a rebirth in the 1970s as a affirmation of Islamic identity and a symbol of piety. © PETER TURNLEY/CORBIS. REPRODUCED BY PERMISSION.

Early in the history of the Islamic community, the form of headgear distinguished Muslims from non-Muslims. While predominantly men's headgear, the *'imama* was worn by some women in Egypt to the consternation of religious authorities in the thirteenth century. While conservative religious authorities disapprove of sartorial gender crossing, ethnographic evidence shows that the borderline between genders in Arab clothing styles was fluid, and more importantly, the sharing of meaning and function of head covers of both sexes was often conceptually embedded in the culture.

The exact origins of the *kaffiyeh* are not clear. What is clear is that pious Muslims wear it as a secular head cover for marking Arab identity, as a symbol of nationalistic or revolutionary struggle, and as religious headgear.

See also **Djellaba; Hijab; Jilbab; Turban; Veils.**

#### BIBLIOGRAPHY

El Guindi, Fadwa. *Veil: Modesty, Privacy and Resistance*. Oxford: Berg, 1999.

Young, William C. *The Rasbaayda Bedouin: Arab Pastoralists of Eastern Sudan*. Case Studies in Cultural Anthropology. Fort Worth, Tex.: Harcourt Brace College Publishers, 1996.

Fadwa El Guindi

**KAIN-KEBAYA** The *kain-kebaya* is a jacket-blouse and wrapper ensemble that forms the basis of national dress for Indonesian women. The long-sleeved *kebaya* comes in two lengths, at the hip (*kebaya pendek*) and near the knees (*kebaya panjang*). The five-centimeter-wide collar-lapel runs from neck to bottom hem. The *kebaya* is closed in two ways—one (*Kartini kebaya*) in which the collar-lapels meet from breast to hip and are closed with broaches or concealed pins, and the second (*kebaya kutu baru*), in which the *kebaya* is open like a jacket, with a rectangular panel bridging the collar-lapels on either side to cover the breasts. The panel is closed at center with four small buttons, or at the side with snaps by the collar-lapel. The *Kartini kebaya* style of closure is found on short and long *kebayas*, while the *kebaya kutu baru* closure style is found on short *kebayas* only. The *kebaya* is made of light-weight material in lace, cutwork, or embroidery, in printed or solid silks, cotton, and synthetics. As Javanese wedding apparel, the *kebaya panjang* comes in velvet with gold embroidery.

*Kain* literally means “cloth”; a traditional Indonesian *kain* is approximately 87 inches (220 cm) long by about 40 inches (100 cm) high and, when wrapped at the hips, extends to ankle length. A *kain* can be batik, silk, or other cotton. A *kain panjang* (long cloth) refers to a batik, a cloth, traditionally cambric cotton, whose surface design has been created by means of wax and dye steps. The *kain panjang* ends could be pleated or arranged in a special drape for formal wear. The *kain* can also be a batik sarong, a rectangle, shorter in length than the *kain panjang*, around 100 inches (180 cm) to 87 inches (220 cm), whose end seams are sewn together to make a tube. A woman wearing a *kebaya* and a batik sarong would still be described as wearing a *kain-kebaya*.

The *kain-kebaya* is worn for both everyday wear and formal wear, distinguished by quality of material and addition of accessories. Central to the *kain-kebaya* is the “belt”—a corded cotton band, *stagen*, that is 40 feet (12 m) long by 5 inches (12.5 cm) wide, that is wrapped around hips to just under the breasts. For formal wear, a solid-colored stole, or *selendang* (88.5 inches [2.25 m] by 20 inches [.5 m] wide) is draped over the right shoulder, folded to a band of about 4 inches (10 cm) wide. In everyday use, the *selendang*, generally in batik, would be worn as a baby carrier in front, or to carry a basket of goods at the back. Hair would be pulled back into a large chignon (*konde*) at the nape of the head; low-heeled sandals, earrings, a necklace, and rings would complete the formal dress.

#### Origin of the Kebaya

The *kebaya* has its origins in a garment brought over by Moslem traders from India. Prior to Moslem influence,

women wore flat textiles wrapped about their body; Moslem influence required that women cover their arms and torsos. They brought over cut and sewn garments. The *baju panjang*, a long-sleeved, knee-length gusseted garment still worn in the early 2000s in the south coast of Sumatra, was the forerunner of the *kebaya* up until the late nineteenth century. The Moslem presence remained in the coastal regions of Java and nearby islands from the fifteenth century, but a central Javanese sultan was aggressive in his spread of Islam by the seventeenth. While no certain evidence exists, it's possible that the *baju panjang* was being worn even then.

As early as 1840, Eurasian women in the north coast of Java began designing and manufacturing batiks for sale to Europeans, Chinese, and other Eurasians. Their batiks made for sarongs were characterized by bold colors, an overall repeat punctuated by a wide panel of triangle border or floral bouquet. Eventually, as evidenced in late nineteenth-century photographs, the predecessor *baju panjang* shortened to the *kebaya pedek* (the short *kebaya* is the default *kebaya*) to better show off the vibrant north coast style of batiks.

The *kebaya kutu baru* (short *kebaya* with panel over the breast) seems to have developed in the late nineteenth century as well, though this subject deserves more research. Djumena states that the panel insert was an innovation developed in Yogya and Surakarta courts, but does not give a date. A photograph dated 1905 of a Javanese regent's family shows one woman in a *kebaya kutu baru* and four others in other styles of *kebaya*.

Taylor calls the kain-kebaya "a costume for all women" in the nineteenth century, because women in villages, royal courts, and European spouses of colonialists (though only at home, as morning attire) all wore them. The quality of the kain-kebaya linked women to the social status of their spouse.

### National Dress

Indonesia's first president declared the Javanese kain-kebaya as Indonesia's national dress for women. In the 1950s and 1960s, it consisted of a *kebaya kutu baru* (with the panel) in sheer floral or lace, with a brassiere visible underneath, the *stagen* exposed, and a central Javanese style batik with or without pleating, the hair in a large *konde* with a jeweled hairstick, low-heeled sandals, narrow, solid-colored *selendang*, pendant on a chain, and stud earrings. This style of dress would be worn for formal occasions.

In the 1980s and 1990s, the kain-kebaya as national dress included stylistic variations as Indonesian fashion designers incorporated textile traditions throughout Indonesia and fashion trends from the Western hemisphere. Iwan Tirta introduced several variations. His *selendang* and *kain pajang*s were matching *batiks*, and were draped on the arm like the 1980s' world fashion of wearing big scarves on the shoulder. His *kebayas* were

always a solid color, and when puffed sleeves were stylish in the mid-1980s, his *kebaya* had them. He popularized the *kebaya panjang* and *Kartini kebaya* that closed in front with ornate broaches. It became acceptable to wear other textile traditions besides batik as national dress. As late as the early 2000s, Indonesian fashion designers popularized the *kebaya*, creating a variety of styles and making it part of leisure world-dress ensemble, as worn with jeans, or skirts, or shorts for middle-class Indonesian women.

See also **Asia, Southeastern Islands and the Pacific: History of Dress; Islamic Dress, Contemporary.**

### BIBLIOGRAPHY

- Achjadi, Judi. *Pakaian Daerah Wanita Indonesia (Indonesian Women's Costumes)*. Jakarta: Djambatan, 1976.
- Djumena, Nian S. *Batik dan Mitra (Batik and Its Kind)*. Jakarta: Djambatan, 1990.
- Gittinger, Mattiebelle. *Splendid Symbols: Textiles and Tradition in Indonesia*. Washington, D.C.: The Textile Museum, 1979.
- Taylor, Jean G. "Costume and Gender in Colonial Java." In *Outward Appearances: Dressing State and Society in Indonesia*. Edited by Henk Schulte Nordholt. Leiden, The Netherlands: KITLV Press, 1997.

Heidi Boehlke

**KAMALI, NORMA** Considered one of America's most original fashion designers, Norma Kamali created innovative and influential garments during the 1970s and 1980s. In the early twenty-first century she continued to market forward-looking fashions. Born Norma Arraez in New York City in 1945, her fashion career might be said to have begun with her outrageous personal style of dressing during her teenage years. It was later refined through formal studies in illustration at the Fashion Institute of Technology (FIT) in New York. After graduating from FIT in 1964, Kamali took several jobs making sketches for Seventh Avenue buyers, only to leave in frustration



### STUDENT TEACHING

The Manhattan Chamber of Commerce gave Norma Kamali the 2001 *Business Outreach Award* for her outstanding work with public school students, particularly those at her alma mater, Washington Irving High School. There, in Room 741 (her former homeroom class), she has created a state-of-the-art design laboratory where she instructs students in fashion design every other week.





**Kamali-designed wedding gown of parachute nylon, 1998.** Norma Kamali's fashions have extended beyond clothing design to include skin care, cosmetics, and perfume. These new avenues, however, have not detracted from the popularity of her designs. AP/WIDE WORLD PHOTOS. REPRODUCED BY PERMISSION.

at the restrictive, stifling environment. Deciding that she wanted the freedom to travel, Kamali took an office position at Northwest Orient Airlines. The airline job allowed her access to cheap travel, a benefit she exploited with frequent weekend trips to London and Paris. There she enthusiastically explored the swinging fashion scene burgeoning in the 1960s.

Her friends and associates coveted the clothes that Kamali brought back from her travels in Europe, and provided the impetus for her to open a boutique in partnership with her husband, Eddie. The shop opened in 1968 on Fifty-third Street and was stocked with garments Kamali purchased abroad. Teaching herself to sew, cut, and make patterns in a very hands-on approach to her design business, she soon began supplementing the inventory with clothes of her own creation.

From the beginning her designs were fresh, original, and entertaining. Inspired by pop culture and street fashion combined with a sense of practicality, Kamali created bold pieces, such as hot pants and leotards. When the store moved to Madison Avenue in 1974, Kamali turned to designing more refined clothing, including tailored suits. Her divorce in 1977 and subsequent

opening of OMO (On My Own) on the Upper West Side marked her true emergence as a designer. Through OMO, Kamali revealed her interest in and identification with a newly independent and creative female customer base.

Kamali is credited with introducing some of the most recognized looks of the 1970s and 1980s. She became a household name after the success of her influential 1980 collection of day and evening wear made from sweatshirt fleece. Inspired by the sleeping bag she supposedly used after her divorce, her quilted down coat design has become a fashion standard. Especially notable is Kamali's drawstring parachute jumpsuit from the mid-1970s, which was included in the Metropolitan Museum of Art's exhibition *Vanity Fair: A Treasure Trove of the Costume Institute* in 1977. In the 1980s, Kamali stressed exaggerated shoulders in her garments and is widely acknowledged as a contributor to the revival of the big shoulder look of that decade.

Kamali has also been a pioneer in swimsuit design. Her earliest pieces were daringly revealing bikinis and gold lamé maillots (one-piece swimsuits for women). She is also credited (along with Calvin Klein) with introducing high-cut bathing suits in 1976, a look that dominated swimsuit styles in the 1980s. In 1985 Kamali introduced a Shirred, 1940s-inspired maillot, revealing her deep interest in retro fashions. Kamali's fresh, updated vintage styles, such as the "Ethel Mertz" wrap dress of the mid-1980s, anticipated the postmodern reprocessing of retro styles that occurred in the next decade. Even in the early 1990s Kamali was ahead of the retro curve, including flared trousers, reminiscent of those styles popular in the 1930s and 1970s, in her collection.

Kamali's creativity has been recognized through a number of awards from such fashion institutions as the Coty American Fashion Critics, Council of Fashion Designers of America, the Fashion Group, and the Fashion Walk of Fame, to name just a few. She remains in 2004 one of America's most inventive and witty designers.

See also **Retro Styles; Swimwear.**

#### BIBLIOGRAPHY

- Baker, Therese Duzinkiewicz. "Norma Kamali." In *The St. James Fashion Encyclopedia*. Edited by Richard Martin. Detroit, Mich.: Visible Ink Press, 1997.
- Diamonstein, Barbaralee. *Fashion: The Inside Story*. New York: Rizzoli, 1985.
- Lencek, Lena, and Gideon Bosker. *Making Waves: Swimsuits and the Undressing of America*. San Francisco: Chronicle Books, 1989.
- Milbank, Caroline Rennolds. *Couture: The Great Designers*. New York: Stewart, Tabori and Chang, 1985.
- Talley, Andre Leon. "True Wit: The Zany World of Norma Kamali." *Vogue* (November 1984): 430-435.

Lauren Whitley

**KANGA** Proverb cloths, called *leso*, *kanga* (*khanga*), or *lamba hoany*, are used and worn throughout coastal East Africa and Madagascar. Often worn in pairs, these lightweight cloths make a lasting impression not only for their brightly colored designs, but also for the messages that are emblazoned upon them.

### History

As early as the 1850s or 1860s, women in the coastal regions of Kenya and Tanzania (perhaps around Lamu or Pate, but most likely in Mombasa or Zanzibar) began buying uncut lineal sheets of six handkerchief squares, called *leso* in Portuguese, cutting the lengths in half and sewing them together lengthwise to create larger rectangular cloths with two rows of three pattern squares each. By 1875, enterprising merchants in Zanzibar began to import modified *leso* from England, Switzerland, India, and the Netherlands. *Leso* eventually also took the name of *khanga*, possibly because a popular early print included small spots similar to the coloration of the guinea fowl, called *khanga* in Kiswahili. Around the turn of the century, *leso/khanga* became especially popular in Zanzibar, appearing at the moment that many former slaves were intent on visually separating themselves from their past and redefining themselves as newly independent, and fashionable, individuals.

In the 1920s a merchant named Kaderdina Hajee Es-sak (nicknamed Abdullah) in Mombasa, Kenya, began adding Arabic script to the lower center section of these brightly colored rectangular cloths. Kiswahili or English phrases in Roman script appeared in the 1960s. Inscriptions incorporate proverbs, popular sayings, greetings, warnings, and political or religious slogans. Use of proverb cloths has since spread along the coast and to the island of Madagascar, with the accompanying text in the appropriate languages. In the middle of the century, textile factories in Africa and Madagascar also began to create proverb cloths for their own markets, although factories in India became dominant cloth-producers for all the regions. Misspellings frequently occur on proverb cloths, probably because many are made abroad for a foreign market in a foreign language. In Madagascar, it is said that *lamba hoany* must have misspellings to be considered true *lamba hoany*, suggesting that this is part of their mystique.

### The Cloths

Proverb cloths are traditionally cotton, but are also made of rayon, polyester, or a variety of blends. Generally three feet high by five feet wide, they have a patterned border (approximately five to nine inches deep) surrounding a patterned interior that usually includes a central design, often within a large circular orb, with four smaller versions of the central design in the four corners. Designs, in either bright and showy colors or quieter earthen tones, typically employ two to five colors upon a white base, and may incorporate virtually any-



In Tanzania, borders are called *pindo*, while the ground (or town) is *miji*, and the four corner motifs (guards of the town) are called *vilindo* (*African Textiles*, June/July and August/September, 1984).

thing, from genre scenes to a variety of objects from nature or images of technology, or food. Specific designs may or may not correspond to the accompanying text, which is located within a box just below the central motif if there is one and just above the patterned border of the long bottom edge.

Lightweight and versatile, proverb cloths are worn primarily by women, although men may also wear them, especially in Madagascar. Often worn in pairs, one may be wrapped around the upper torso and the other worn as a skirt. They can be worn singly as dresses: a girl wrapping the cloth around her body with the two ends overlapping in front and their upper corners tied behind her neck, a woman wrapping it around her body with the upper edge above her breasts and then either rolled under or over itself or the two upper corners tied in a knot. They can serve as an outer cape to protect one from cold or heat, with the top edge raised over the head to form a hood if necessary. Women often wrap proverb cloths around their waists as a protective layer over their other clothes while working. Proverb cloths can cradle a baby against one's back, with the ends either over both shoulders, under one's arms, or one over and one under an arm, the ends twisted, tied, or held in front. If twisted lengthwise and curled into a flat spiral or doughnut shape, proverb cloths make cushions when carrying a heavy or unwieldy load on one's head. They are often used to wrap objects or parcels, or to cover the contents in a basket. They are also increasingly used as wall hangings, bedspreads, curtains, or seat covers. Finally, in some regions, kangas are essential accessories when attending funerals or weddings.

### Communicative Tools

A person may communicate through a proverb cloth depending on how, where, or when it is worn, displayed, or given. A person can wear a cloth so that the intended recipient of the message may see it, by walking past their house or business, by visiting a neighbor, or by wearing it at home. Messages may warn a gossiping neighbor, a rival co-wife, or an erring husband, or may indicate one's friendship or love. For example, a woman may show her affection by wearing the cloth that her husband has just removed, or she may place her cloth on her husband's pillow to indicate that she would like his attentions. Proverb cloths can also be given as gifts, by one's mother,



### EXAMPLES OF PROVERBS

*Utabaki na chokochoko utaambulia ukoko.* "By continuing to create discord, all you'll end up with is just leftovers." Tanzania (Hassan).

*Kunisalimia tu haitoshi.* "It is not enough just to greet me." Kenya (Troughear).

*Fanahy tsara no maha olona.* "A good character makes the person." Madagascar (Green, personal translation).

spouse, parent, grandparent, lover, rival, or friend. Lovers may also send perfumed cloths to emphasize their romantic intentions.

Meanings behind messages, the identity of a message's recipient, as well as the intent of the sender can be ambiguous. However, a person can wear a proverb cloth without intending to send a message, or can wear it with a very specific person(s) in mind. Moreover, the symbolic proverbial sayings may have multiple interpretations or meanings. The responsibility of recognizing a communicative exchange, therefore, rests with the viewer, who must decide whether a message is intentional, and if so, if it applies to him or her. A woman can therefore send a rival or friend a message without risking the social stigma of inciting argument or confrontation, since she can always deny that a message was intended. The woman wearing or giving a cloth, who has the exclusive knowledge of its intent, is therefore in a position of power, and the recipient, who has the disadvantage of not knowing whether a message is intended, is disempowered (see Beck for an extended discussion). Proverb cloths, therefore, are a beautiful yet complex mode of communication and power.

See also *Africa, North: History of Dress; Africa, Sub-Saharan: History of Dress.*

#### BIBLIOGRAPHY

- Abdullah, Fatma Shaaban. *Kanga Textiles From Tanzania: 1 June–1 July 1984*. London: Commonwealth Institute, 1984.
- Anonymous. "Kanga Textiles from Tanzania." *African Textiles* (June/July 1984): 5.
- Anonymous. "Kanga Textiles from Tanzania." *African Textiles* (August/September 1984): 24–25, 27.
- Beck, Rose Marie. "Aesthetics of Communication: Texts on Textiles (Leso) from the East African Coast (Swahili)." *Research in African Literatures* 31, no. 4 (2000): 104–124.
- Fair, Laura. "Dressing Up: Clothing, Class and Gender in Post-Abolition Zanzibar." *Journal of African History* 39 (1998): 63–94.

Green, Rebecca L. "Lamba Hoany: Proverb Cloths From Madagascar." *African Arts* (Summer 2003).

Hamid, Mahfoudha Alley. "Kanga: It Is More Than What Meets the Eye—A Medium of Communication." *African Journal of Political Science, New Series* 1, no. 1 (1996): 103–109.

Ndwiga, Robert. "Be It Love or Sorrow, Say It With Khangas." *The East African (Nairobi)* 8, part 2 (2000).

Troughear, Tony. "Khangas, Bangles and Baskets." *Kenya Past and Present* 16 (1984): 11–19.

#### Internet Resources

Ali, Hassan. "Kanga Writings." 1995. Available from <<http://www.glcom.com/hassan/kanga.html>>.

Hanbys, Jeannette and David Bygott. 1984. "The History of Kanga." Available from <[http://www.glcom.com/hassan/kanga\\_history.html](http://www.glcom.com/hassan/kanga_history.html)>.

Rebecca L. Green

**KARAN, DONNA** Donna Karan (1948– ) was born Donna Ivy Faske in 1948 in New York City. Her father, Gabby Faske, was a custom tailor who died in a car accident when Donna was three years old. Her mother, Helen Faske, had been a showroom model turned fashion sales representative. Helen's second husband was Harold Flaxman, who was also involved in the garment business. The family moved to Long Island after the marriage. By the time Karan finished high school, she had already staged her first fashion show. She attended the Parsons School of Design for two years, leaving at the age of nineteen to work for the ready-to-wear designer Anne Klein. Klein fired Karan in short order, but rehired her two years later. When Anne Klein died of cancer in 1974, Karan was put in charge of Klein's Seventh Avenue sportswear company at the age of twenty-six, just days after having given birth to a baby girl.

During Karan's decade-long tenure as head designer, she built Anne Klein into the most profitable sportswear company in the United States. She launched Anne Klein II, a so-called bridge line of clothes priced slightly lower than the signature collection and meant for the working woman. So successful was the concept that the company's financial backers, Tomio Taki and Frank Mori, invested \$10 million in working capital for Karan to start her own collection. She turned over the reins at Anne Klein to her assistant, Louis Dell'Olio, in 1984.

Long since divorced from Mark Karan, the father of her ten-year-old daughter, and remarried in 1983 to her business partner Stephan Weiss, Donna Karan set out to "design everything I needed, so I wouldn't have to think about it anymore" (Agins, p. 145). To this end, she devised a sophisticated twist on the mix-and-match concept and called her line Donna Karan Essentials. It consisted of a bodysuit, tights, dress, skirt, jacket, pants, and accessories—"seven easy pieces" meant to be replaceable with minimal updating. It was a modern way of dressing de-



signed to go from day to evening, pack easily in a travel bag, and be ready to wear at a moment's notice.

"I don't like fashion," Karan once said. "To me, it's the woman, the body." She described herself not as a fashion designer but as a "doctor for women's problems." She added, "In all the chaos I live in, I always want to create calm." In the 1980s, a time when many professional women in the United States were dressing in pinstriped power suits and collared silk blouses with bows at the neck, Karan provided an attractive alternative. Her system of dressing was based on a cashmere bodysuit, on top of which could be layered silk body blouses, sweater-like jackets, unconstructed blazers, and easy-fitting skirts or trousers. "I have seen women transform themselves when they put on her clothes," said Kal Ruttenstein, fashion director of Bloomingdale's department store. "They make you look sexy and strong, a rare combination."

In addition to answering her own needs and those of many other women, Karan drew inspiration from the pace and attitude of New York City, naming her collection Donna Karan New York. Soon the label included fragrance and beauty products, a men's collection, a children's line, and a home furnishings collection. In 1989 she launched DKNY, a casual line of less expensive, more youthful fashions. Designed by Jane Chung but overseen by Karan, DKNY also quickly expanded to include a wide range of licensees.

The company was publicly traded on the New York Stock Exchange for the first time in 1996. In April 2001 Donna Karan New York was acquired for \$643 million by the French luxury goods conglomerate Moët Hennessy Louis Vuitton (LVMH). What was then known as Donna Karan International had over eighty freestanding Donna Karan and DKNY retail locations worldwide, including the original two stores in London and three in New York City. Karan has been a six-time winner of awards from the Council of Fashion Designers of America.

See also **Seventh Avenue; Sportswear.**

#### BIBLIOGRAPHY

- Agins, Teri. "Woman on the Verge." *Working Woman*, May 1993, p. 145.
- Horyn, Cathy. "Review/Fashion; Up Close and Personal: Karan, Kors, Rucci." *New York Times*, 25 September 2001.
- Karan, Donna. *DKNY: Soul of the City*. New York: Universe, 1999.
- Singer, Sally. "Love Story." *Vogue*, September 2001.
- Sischy, Ingrid. *Donna Karan: New York*. New York: Universe Books, 1998.

*Liz Gessner*

**KENTE** Kente cloth is probably the most universally recognized of all African fabrics. The word "kente" means basket, and the cloth is so-named because of its resem-

blance to a woven basket design. The Asante peoples of Ghana and the Ewe of Ghana and Togo weave it on horizontal, narrow-strip, men's treadle looms. Individual strips of kente typically feature alternating segments of warp-faced (yarn extended lengthwise in a loom) stripe patterns with weft-faced (yarn running crosswise) geometric patterns. The woven strips range from three to five inches in width and are sewn together edge-to-edge to produce men's cloths of approximately twelve feet by six feet (twenty-four strips) and women's cloths of six feet by three to four feet (nine to twelve strips). Men's cloths are worn toga style, draped around the body with the left shoulder and arm covered and the right shoulder and arm exposed. Women wear two cloths of different sizes as upper and lower wrappers and often have a third piece as a baby carrier. Queenmothers and more recently other women of stature may wear a single cloth like a man. Regardless, kente is primarily festive dress worn at a variety of annual festivals. It is also used in other traditional contexts as a drum wrapper, a palanquin liner, umbrella fabric, fan and shield covering, amulet casing, and even loincloths. More recently it has been used as a wall hanging in Ghana's Parliament House and in the United Nations. Traditional usage aside, some African and African American scholars still vehemently contend that the use of kente should be restricted to clothing for special occasions.

Weaving in what is now southern Ghana was certainly introduced from the north where strip-woven fabrics are known from at least the eleventh century in the Bandiagara escarpment region of modern Mali. There is considerable debate between the Asante and Ewe over the historical preeminence of their respective traditions. Since both are derived from more northerly practices, the argument is largely irrelevant, but for ethnic pride. Asante kente is held in high regard, and has had by far the more pervasive international significance. As the Asante kingdom rose to power in the late 1600s, the weaving of kente became the exclusive prerogative of the Asante king and his designates. Royal control of this elite fabric persisted for two hundred years, but toward the end of the nineteenth century, kente became increasingly accessible to those who could afford it. Beginning with the conquest of the Asante in 1874 by the British, the history of kente is one of increasing democratization.

Part of the appeal of Asante kente is not just visual. The Asante value the names of various cloths as much as they do their appearance. Cloths are named after their warp stripe patterns and may reference past kings, and queenmothers, historical events (for example, the "Queen comes to Ghana," commemorating Queen Elizabeth's visit in 1961), the plant and animal kingdoms ("little peppers," "guinea fowl feathers"), and other natural phenomena ("gold dust," "the rainbow," "the rising sun"). Traditional proverbs are among the most popular names. One pattern is titled "When you climb a good tree you get a push," that is, if your intentions are good people will help you. Another is called "Kindness does

not travel far,” referring to the idea that bad deeds attract more attention than good. The above aside, only rarely is there a visual correlation between the cloth’s name and its appearance. Although the overall cloth is named after the warp pattern, weft designs are also named. Here there is more visual correspondence with the name, with designs called “comb,” “hat,” “knife,” and “drum” being relatively descriptive. The narrative and indeed intellectual component of kente nomenclature is also undoubtedly important to its popularity in international fashion.

Kente cloth first gained exposure on the international scene with the rise of Kwame Nkrumah and the independence of Ghana in 1957. As the first sub-Saharan African country to regain its independence from colonial domination, Ghana, with Nkrumah as its first President, attained enormous symbolic stature for the rest of Africa and for African Americans—many of whom visited Ghana just before or after independence. This includes such renowned figures as Maya Angelou, Muhammad Ali, John Biggers, Ralph Bunche, W. E. B. Du Bois, Thurgood Marshall, Adam Clayton Powell, Roy Wilkins, Richard Wright, and Malcolm X, to name only a few. Most, if not all, returned with a piece of kente as a potent connection with their African heritage and identity.

Of equal or greater importance, Kwame Nkrumah visited the United States in 1958 and 1960 with an entourage of kente-adorned Ghanaian dignitaries, who appeared in photographs in many of the most important publications of the day, including *Life*, *Time*, and *Ebony* magazines, and *The New York Times* and *The Washington Post* newspapers.

Since Americans were unaccustomed to wrapped and draped clothing, kente was first used primarily as interior decoration—a furniture throw, wall hanging, or even a bedspread. But very quickly kente cloth was tailored into women’s blouses, skirts, and dresses and even men’s jackets, all of which otherwise followed styles prevalent in the 1960s and 70s. During this period kente wedding attire was especially popular.

The fact that handwoven kente was expensive, difficult to obtain, often uncomfortably warm and heavy, and hard to tailor led to the production of mill-woven roller-printed cloths in a variety of kente patterns beginning about 1960 and continuing into the twenty-first century. Asante and Ewe weavers naturally object to calling this material “kente,” but it has entered popular parlance as such.

Both hand- and mill-woven kente have entered the contemporary fashion world in a variety of forms. Kente-covered jewelry includes earrings, pins, and bracelets, and is still popular, as are a variety of hair ornaments such as headbands, barrettes, and scrunchies. Kente hats, purses, shoes, and sandals can still be purchased in Ghanaian markets, and kente backpacks and book bags are popular tourist items.

While kente fabrics and designs can still be found internationally in a number of contexts, the use of kente in the United States persists, especially at liturgical and academic events where the robes of choirs and church leaders, as well as graduation robes, either incorporate or are augmented by a single strip of kente called a “stole.” Since religion and education are of paramount importance to African American communities, it is fitting that kente still plays a profound role in these life-sustaining and family-centered institutions.

See also **Africa, Sub-Saharan: History of Dress; African American Dress; Kente; Weaving.**

#### BIBLIOGRAPHY

- Adler, Peter and Nicholas Barnard. *African Majesty: The Textile Art of the Ashanti and Ewe*. London: Thames and Hudson, 1992. Features a stunning collection of kente.
- Lamb, Venice. *West African Weaving*. London: Duckworth, 1975. Focus is on kente, but locates it in broader West African tradition.
- Menzel, Brigitte. *Textilien aus Westafrika*. 3 vols. Berlin: Museum für Völkerkunde, 1972 and 1973. Catalogue of Berlin collection; Volume 1 has extensive documentation of warp and weft names.
- Rattray, Robert S. *Religion and Art in Ashanti*. Oxford: Clarendon Press, 1927. First edition is remarkable for its color plates of warp patterns.
- Ross, Doran H., ed. *Wrapped in Pride: Ghanaian Kente and African American Identity*. Los Angeles: UCLA Fowler Museum of Cultural History, 1998. Comprehensive study, brings history of kente up to the twenty-first century.

Doran Ross

**KEVLAR.** See **Techno-Textiles.**

**KHAKIS.** See **Trousers.**

**KILT** The kilt has come to signify a natural and unmistakable masculinity, but it has a long history of outside intervention and deliberate reinvention. From its origins as the basic garb of the Highlander, Scotsmen and non-Scotsmen alike have embraced it as uniform, formal and semiformal wear, and casual, everyday wear. The kilt’s ability to remain recognizable while responding to changing circumstances and consumer demands has been instrumental in maintaining its popularity through successive generations and, increasingly, throughout the world.

#### Form and Evolution

The kilt as we know it today originated in the first quarter of the eighteenth century. Known to the Gaelic-speaking Highlander as the “little wrap” (*feileadh beag*), it evolved from the “big wrap” (*feileadh mor*), or belted

plaid, the first identifiably “Scottish” costume that emerged in the late sixteenth century. Earlier, the Scottish Gaels had worn the same clothes as their Irish counterparts, namely a shirt known in Gaelic as the *léine* and a semicircular mantle known in Gaelic as the *brat*.

The belted plaid consisted of a four- to six-yard length of woolen cloth about two yards wide. In *Highland Costume* (1977), John Telfer Dunbar explains how the belted plaid was arranged on the body. It was laid out on the ground and gathered in folds with a plain section left at each side. The man lay down on it with one selvaige at about knee level, and fastened it with a belt. When he stood up, the lower part was like a kilt, and the upper part could be draped around the body in a variety of different styles. Several dress historians, however, have discounted this method on the grounds of impracticality. They propose that the most pragmatic and time-effective method was to gather the pleats in the hand, pass the plaid around the body, secure it loosely with the belt, and then tighten it after a final adjustment of the pleats.

The kilt as worn in the early 2000s is the lower half of the belted plaid with the back pleats stitched up. Its invention is credited to Thomas Rawlinson, an English ironmaster who employed Highlanders to work his furnaces in Glengarry near Inverness. Finding the belted plaid cumbersome, he conceived of the “little kilt” on the grounds of efficiency and practicality, a means of bringing the Highlanders “out of the heather and into the factory” (Trevor-Roper 1983, p. 22). However, as Dorothy K. Burnham asserts in *Cut My Cote* (1973), it is more likely that the transformation came about as the natural result of a change from the warp-weighted loom to the horizontal loom with its narrower width.

### Romanticism: The Kilt as National Dress

Not long after the kilt’s invention, the Diskilting Act was passed in the wake of the Jacobite Uprising of 1745. This rebellion, organized by Prince Charles Edward Stuart (Bonnie Prince Charlie), marked the final attempt by the Jacobites to regain the British throne. As in the previous Jacobite risings, the “Young Pretender” sought and won the support of many Highland chiefs and their clans. When the Jacobites were defeated at the Battle of Culloden (1746) by the duke of Cumberland and his troops, a campaign of “pacification” of the Highlands was undertaken “beginning with fire and the sword, and leading on into social engineering of various kinds” (Chapman 1992, p. 125). The latter included the proscription of Highland costume, which was seen as a symbol of rebellion and primitive savagery.

The Diskilting Act made an exception for those serving in the armed forces. Originally, the Highland regiments were dressed in the belted plaid, but in order to conform to the other regiments of the British Army they wore a red coat cut away at the skirts to allow for its voluminous folds. Other distinctive Highland features of the uniform included a round blue bonnet, a small leather

sporrán, red and white knee-length hose, and black buckled shoes. By about 1810, however, the Highland regiments had replaced the belted plaid with the little kilt. At the same time, the small, practical leather sporran developed into a large, hairy, decorative affair. This early-nineteenth-century military style was to have a lasting impact on civilian dress. Several dress historians have claimed that Highland costume would not have survived in civilian form had the Highland regiments not been raised and uniformed in elements of their native dress.

In 1782, through the efforts of the Highland Society of London, the Diskilting Act was repealed. By the time of the repeal, the kilt had fallen out of use as an item of ordinary dress, allowing for what Malcolm Chapman in *The Celts: The Construction of a Myth* (1992) calls the “romantic rehabilitation of Highland dress.” The romantic gaze was a reaction against the urban and the industrial and a celebration of the untamed wilderness. No longer the threat from the North, the image of the Highlands could represent this wilderness within the bustling economy of the “new” Britain. Rather than dangerous, bare-legged barbarians, the Highlanders became admirable, a kilted version of the noble savage.

The romantic rehabilitation of the kilt reached its apotheosis with King George IV’s carefully stage-managed state visit to Edinburgh in 1822, during which he disported himself in full Highland dress. This “publicity stunt” promoted the kilt as fashionable wear among the Scottish nobility and, in so doing, helped establish the kilt as the national dress of Scotland. However, the king’s clothes, like those worn by Scottish noblemen, were far removed from those worn by the Highlanders of the previous century. Given the fact that they were largely designed for the levee, assembly, and ballroom, the emphasis was on the dramatic and spectacular. As Hugh Cheape points out in *Tartan* (1991), “‘Highland dress’ turned into ‘tartan costume.’ A practical dress with style became . . . a fashionable dress with little regard for function” (Cheape 1991, p. 52).

Throughout the nineteenth century, aristocratic patronage continued to provide cachet for this new urban-based national style, which began to have “correct” items and styles of wear for day and evening. From the 1840s, it was given new impetus through Queen Victoria’s cult of the Highlands. Queen Victoria shared King George IV’s romantic vision of Scotland, and in 1852 Prince Albert bought Balmoral Castle in Aberdeenshire. Parts of the interior, most notably the queen’s private suites, were decorated with tartan. Queen Victoria herself wore dresses made from “Dress Stewart” or “Victoria” tartan, sparking a trend for tartan fashions worldwide. It was not until the twentieth century, however, that women embraced the kilt as fashionable attire. After World War II, a simplified version of the kilt emerged in the form of a pleated, wrap-around skirt belted at the waist and secured near the hem with a large pin. Popular with middle- and upper-class women, it also formed a component of the



uniforms of private girls' schools in England and America, thus maintaining the kilt's connotations of wealth and class privilege.

### Re-contextualization

As Scotland gained a new level of cultural and political confidence toward the end of the twentieth century, "a new generation of [young] radical Scots . . . reclaimed the wearing of the kilt from the embrace of nearly two hundred years of establishment, commodified gentrification" (Taylor 2002, p. 220). The Victorian styles of day wear and evening wear gave way to contemporary usage. Many younger Scotsmen began to wear their kilts for everyday use with a T-shirt or sweater, a denim or leather jacket, sneakers or chunky, heavy-soled boots, and woolly socks falling around the ankles. As Lou Taylor observes in *The Study of Dress History* (2002), "Now young Scotsmen wear their kilts according to their own cultural codes and on their own national identity terms" (Taylor 2002, p. 220).

Recently, the kilt has become increasingly popular among non-Scotsmen wishing to project a self-confidently fashionable image. This can be attributed, at least in part, to the immense success of such films as *Rob Roy* (1995) and *Braveheart* (1995). In the tradition of the Romantic movement of the late eighteenth and early nineteenth centuries, these films portray the Highlander as "warrior hero," embodying timeless, masculine values. This image has been reinforced in the arena of sport, most obviously through the Highland Games, now broadcast around the world. In putting the shot, tossing the caber, and throwing the weight, men of obvious stamina are shown competing in kilts. Most recently, however, Scottish football supporters have promoted the Highlander as a beau ideal. Their tribal antics and kilted uniforms received widespread publicity in France during the World Cup in the summer of 1998. Through such images, the kilt has come to represent a ready access to Highland male sexuality. For non-Scotsmen, it provides the means of asserting a self-consciously yet unambiguously masculine persona.

Contemporary designers have drawn heavily on the kilt's hypermasculine connotations in their attempts to appeal to the young fashion-conscious male. At the same time, various designers have attempted to blur the lines between the "kilt" and a "skirt" by re-working elements of the kilt's design. Most typically they have focused their efforts on foregrounding the cut over the culturally specific tartan, employing nontraditional "street" materials like denim or leather, and even adapting its cut, length, and construction. These "skirt-kilts" offer men a means of expressing a frank masculinity while simultaneously projecting a self-confidently unconventional persona. As such, they have proved particularly successful among youth and countercultural movements such as punks in the 1970s and new romantics in the 1980s. Since the early 1990s, kilts and skirt-kilts have entered the lexicon of gay fashion. Worn by gay men as an expression of hyper-

masculinity and a flaunting of perceived femininity, the kilt has become a standard item in the masculinized gay wardrobe.

See also **Europe and America: History of Dress (400–1900 C.E.); Gender, Dress, and Fashion; Tartan; Uniforms, Military.**

### BIBLIOGRAPHY

- Burnham, Dorothy, K. *Cut My Cote*. Toronto: Royal Ontario Museum, 1973.
- Chapman, Malcolm. *The Celts: The Construction of a Myth*. London: Macmillan, 1992.
- Cheape, Hugh. *Tartan: The Highland Habit*. Edinburgh, U.K.: Weatherhill, 1991.
- Dunbar, John Telfer. *Highland Costume*. Edinburgh, U.K.: Laurier Books Ltd., 1977.
- . *The Costume of Scotland*. London: B. T. Batsford, Ltd., 1981.
- Scarlett, James D. *Scotland's Clans and Tartans*. Guildford, U.K.: Lutterworth Press, 1975.
- Taylor, Lou. *The Study of Dress History*. Manchester, U.K.: Manchester University Press, 2002.
- Trevor-Roper, Hugh. "The Invention of Tradition: The Highland Tradition of Scotland." In *The Invention of Tradition*. Edited by Eric Hobsbawm and Terence Ranger. Cambridge, U.K.: Cambridge University Press, 1983.

Andrew Bolton

**KIMONO** Around the world, the kimono is recognized as the national dress of Japan. Made from a single, long fourteen-inch-wide bolt of silk, the kimono has an overall T-shape, with its component parts joined mostly in straight, vertical seams. In contrast to typical Western garb, the kimono is flat rather than three-dimensional, and angular, not form-fitting. It is more an expression of surface design by means of dyed and/or embroidered patterns than a product of tailoring and weave.

The term "kimono" was coined during Japan's first era of modernization, the Meiji Period (1868–1912), in response to the heightened awareness of the Japanese to Western clothing, customs, and ideas. Japan had recently emerged from an enforced period of isolation with feelings of self-consciousness in regard to their dress as compared to that of occidentals. A dichotomy was established distinguishing Western clothing (*yōfuku*) from native dress (*wafuku*).

Kimono, the best-known article of traditional clothing, takes its name from the verb *kiru*, meaning "to wear," and *mono*, meaning "thing." In its narrowest sense, the kimono is the descendant of the *kosode*, a former undergarment that emerged prior to the Edo period (1603–1868) as the principal article of dress most sensitive to changes in styles and fashion. More broadly, kimono can refer to any traditional Japanese T-shaped garment, whether worn by men or women in any con-

text—sacred or secular, for weddings or funerals, onstage or at festivals, or simply for relaxing at home.

### Kosode/Kimono Parameters

The kosode takes its name from the adjective *ko*, meaning “small,” and *sode*, for “sleeve.” In that a kosode/kimono sleeve has the appearance of a large pouch, it is difficult to consider the kosode sleeve as being small. In fact, what is small relative to the overall sleeve size is the opening through which the hand passes. The kosode sleeve opening is so-named in contrast to the *ōsode* sleeve, which is entirely open and unsewn.

The kosode took precedence over the *ōsode* as the primary vehicle for fashion, while the *ōsode* was relegated to conservative milieus such as court rites, religious rituals, and the no theater. Other variations in construction include the absence or presence of a lining, wide lapels that overlap or narrow ones that abut, a flat collar, and the occasional use of padding. When the front panels of the robe are wide enough to overlap, the left front panel is always closed over the right side. The obi is a sash used to secure the robe around the body.

Distinctions existed among kosode of the past, some of which are still current in kimonos. One type of kosode, the *furisode* (literally, “swinging sleeves”) has sleeves especially long in their vertical dimension. The *furisode* is reserved for unmarried girls. The *katabira*, for which the nearest modern descendant is the *yukata*, was unlined and not made of silk, but rather of a bast fiber (usually hemp or ramie). Two other types of kosode, called *koshimaki* and *uchikake*, were worn as outer robes on top of another kosode. The *koshimaki* was densely embroidered with small auspicious motifs and draped around the hips while held in place by an obi. It became obsolete; however, the *uchikake*, worn like a cape and not fastened at the waist, had a thickly padded hem and was still being worn at marriage ceremonies in the early 2000s.

### Early Styles

After the kosode ceased to be the plain, unpatterned silk garment worn next to the skin under layers of voluminous robes, as in the Heian Period (794–1185), it served as outerwear, initially for the lower classes and eventually for the samurai class and the aristocracy.

One of the first discernible styles in kosode, *nuihaku*, featured decoration in embroidery (*nui*) and metallic foil (*baku*). In some examples, the robe’s markedly contrasting sections differ in both motifs and color schemes. Another early style, known by the poetic name *tsujigabana* (literally “flowers at the crossroads”), was technically exacting, involving careful tie-dyeing, delicate ink painting, and, occasionally, embroidery and applied metallic foil. Some kosode patterned in this fashion were only decorated at the shoulders and hem, with the midsection left empty.

### Kanbun Style

The earliest style for which there is considerable pictorial and written documentation, as well as extant garments, is known as Kanbun (1661–1673) after the Japanese era of that name. Order books from the Kariganeya clothing atelier in Kyoto, which catered to samurai class and aristocratic clients, reveal an exuberant asymmetrical style often featuring large-scale motifs in a sweeping composition extending from the shoulders to the hem, with the left body panel (as viewed from the back) mostly free of decoration in its midsection. The broad, flat expanse of surface area and the T-shape, two characteristics inherent in *kosode* construction, are exploited to their full design potential in such robes.

In Kanbun kosode, tiny tie-dye spots were used extensively in the creation of individual motifs, and in combination with embroidery in polychrome silk threads and gold and silver threads. Occasionally, written characters in a flowing script were incorporated into the design scheme, adding a literary aspect and creating deeper levels of meaning in the pattern by combining words with individual design motifs.

The two most elite (and, eventually, most conservative) levels of society, the aristocracy and the samurai class, were patrons of this bold and innovative style. The earliest published kosode design books (*hinagata-bon*), printed from wood blocks to allow for wide dissemination, also featured the Kanbun style, indicating there was also a popular audience for this new fashion. Members of the nouveaux riche merchant class had the money to afford such expensive robes, although they were at the bottom of the social scale, below farmers and artisans.

Kosode design books allowed a larger public to keep pace with changing fashions. A client would select a design from such a book, then choose colors from an album of dyed fabric swatches; after which a kosode maker, in collaboration with a dyer, would produce the finished product. The concept of ready-to-wear clothes for both Western-style garments and kimono did not have an impact in Japan until after World War II. Even as late as the early twenty-first century, most finer kimonos were still made to order, like haute couture in the West.

### Genroku and Yōzen Styles

The next dominant style is named for the Genroku years (1688–1704). During this time women’s obi grew wider, and therefore more prominent as a fashion accessory. Many different methods were invented for tying the obi, adding another element to the repertory of styles available to fashionable women. The obi was now usually knotted at the back.

As the obi widened, the sleeves of the *furisode*-type kosode lengthened even more and its unpatterned space diminished, although the shoulder-to-hem Kanbun-style sweeping design composition was more-or-less preserved. The overall effect was one of opulence, as the de-

sign filled up more space and the wider obi added a further expanse of decoration.

The Kabuki theater, a new and raucous form of popular entertainment, enjoyed a wide audience in the urban centers where the merchant class was based. Since women were banned from the Kabuki stage, male actors also played the female roles. They launched fashion trends in women's kosode, particularly by popularizing certain shades of colors and individual design motifs. Woodblock print publishers had eager urbanites lining up to buy the latest images of Kabuki stars, and also of geisha, who were the female trendsetters of the moment. By this time, men's kosode were no longer interchangeable with women's dress, except within the Kabuki and brothel demimonde.

Another style that emerged during the Genroku years was named after a Kyoto painter, Yōzensai Miyazaki, and is simply referred to as *Yōzen*. He is believed to have popularized a technique that combined freehand painting and paste-resist dyeing using a wide variety of colors and allowing for the production of highly pictorial imagery and unusual shading effects on kosode.

Yōzen kosode represented a uniquely Japanese achievement in the costume arts. Whereas technological advances in textile production had previously been initiated on the Asian mainland (especially in China) and were later copied and refined by the Japanese, a new means of decoration involving the skill of the dyer and the hand of the painter had been created in Japan itself. The nearest equivalent to Yōzen in textiles outside of Japan is Indian chintz, which, however, utilizes cotton fabric rather than silk and makes less use of freehand painting and shading effects. Yōzen remains a popular technique for the decoration of kimono in the early 2000s.

### Late Edo-Period Styles

Extravagance in Genroku and Yōzen-style kosode led the Tokugawa authorities to enact sumptuary laws from time to time, leading to restrictions on the use of certain colors for the lower classes and to controls on some of the more costly textile techniques. Apart from the sumptuary laws, which were randomly enforced, a reaction against flamboyance and excess became the underlying basis for a new style.

Esthetic terms such as *iki* and *shibui* were used by trendsetters who dressed in kosode with a simple striped pattern in subdued colors, or who chose a quiet ikat-patterned fabric for their robes. Other kosode were decorated only along the hem, with the remainder of the garment devoid of design except for traditional family crests arrayed across the shoulders. Subtlety, with a touch of luxury, could be conveyed by wearing a plain kosode with a richly decorated lining.

Excess was not completely forgotten during the late Edo period. The Bunka-Bunsei years (1804–1830) saw the production of many densely embroidered kosode rich

in gold thread and that were often chosen by brides for their weddings. Even Buddhist monks commissioned extravagantly woven ritual robes during this period.

A trend in kosode of the Samurai class played on the juxtaposition of certain design motifs alluding to literary works from Japan's medieval period. Another style, which continued into Japan's modern era, was based on the work of the Shijō-Maruyama school of painting, whose artists were influenced by Western painting techniques such as the use of perspective. Several of these painters were recruited to work on kosode designs, and were able to successfully adapt their landscape, bird, and flower themes to the T-shaped garment.

### Meiji Period (1868–1912)

In the 1850s, Japan was forced to end its policy of isolation when militarily superior Western powers demanded trading concessions. China, which had historically been the fount of culture for Japan, as ancient Greece and Rome had been for the rest of Europe, was then under the yoke of Western imperialism and was no longer considered to be a suitable role model for the Japanese.

When power was assumed by the Meiji emperor in 1868 after the shogunate collapsed, the elite of Japan embarked upon a serious program of studying and emulating Western technology and customs, including dress. In 1887, the Meiji empress issued a statement denouncing the wearing of kimono as harmful to the female body and advocated the Western blouse and skirt as a more practical form of women's wear.

However, only wealthy women who moved in international circles felt the need and had the means to dress Western style. The long kimono and its wide, tightly bound obi made chair sitting a challenge. In the traditional Japanese home, kimono-clad women sat on a tatami mat-covered floor with their lower legs folded under their thighs. Most women continued to wear kimonos, as they did not lead public lives and had no occasion to experience Western-style interior decor. The daughters of Meiji women did, however, improvise a sort of Western two-piece outfit to serve as school dress. They wore their kimonos tucked into *hakama*, the traditional skirtlike trousers, which had most recently served as part of formal dress for samurai-class men during the Edo period.

For urban men, whose lives were led in public while their wives stayed home, uniforms based on European models were worn in the exercise of certain professions. If a man had the means, he could visit a tailor and be fitted for a suit, which would invariably be made of wool, a fiber Japan itself never produced. Otherwise, at least a token article of Western dress would be worn in public, such as the bowler hat.

Meanwhile, in the West, kimonos appealed to certain sophisticates who developed a passion for things Japanese. Numerous portraits were painted of Western women in kimono during the latter part of the nineteenth



century. The kimono could add both an exotic and an erotic flavor to a painting. Puccini's *Madame Butterfly* and Gilbert and Sullivan's *The Mikado* put the kimono on stage in front of large audiences in Europe and the Americas. Fashion designers such as the Callot sisters and Paul Poiret were inspired by the kimono shape.

### Taishō Period (1912–1926)

Japan continued to modernize and prosper during this period. When a major earthquake seriously damaged Tokyo in 1923, much of the city was rebuilt in a more Western style, making Western attire more practical in the new modern interiors. The kimono and other traditional dress for women were further marginalized as female students started to wear blouses and skirts instead of kimono tucked into *bakama* (although such an outfit can still be seen at graduation ceremonies), and as more women entered the workforce.

### Shōwa Period (1926–1989)

Militarism came to the fore in 1930s Japan, eventually leading to the disaster and devastation of World War II. Rampant nationalism did not bring about a revival of the kimono. Women were needed to fill jobs abandoned by men in the armed forces, and kimonos were impractical as work clothes. Fabric was rationed, and the kimono was seen as wasteful, requiring more material than Western-style clothes. During the occupation period following Japan's defeat, many families were forced to sell or barter heirloom kimonos for daily necessities, causing yet another setback to the tradition of kimono wearing.

However, economic recovery and prosperity created a large middle class in Japan, resulting in an increase in disposable income and leisure time. Housewives now sought to cultivate themselves by engaging in traditional arts such as flower arranging and tea ceremony, for which kimono was the appropriate dress.

Department stores became major retailers of kimonos, which were still made to order from narrow bolts of silk. Brides continued to dress in kimonos for weddings (but would also change into a Western-style wedding dress for a portion of the ceremony), and might even enroll in a school at which the proper choosing and wearing of the kimono and obi were taught. Traditional annual events, such as New Year festivals and coming-of-age ceremonies, were further occasion for kimono wearing, although primarily for women and children.

Colors and patterns in kimono did change from year to year, but the burst of creativity in surface design and dyeing of the Edo period has yet to be equaled. The modern kimono represented a middle-class rediscovery of a traditional garment. Its role is minor, or nonexistent, in the lives of Japanese women in the early twenty-first century, with the exception of the geisha, who continued to wear kimono with a sense of style while entertaining men.

However, kimonos did experience another incarnation in postwar Japan as art objects. Certain artisans who

continued to practice traditional crafts, including textiles, were designated "Living National Treasures" by the Ministry of Culture. Two of the best-known Treasures in the field of textiles, Kako Moriguchi and Keisuke Serizawa, had some of their fabric production made into kimonos, which were subsequently shown at exhibitions and collected as works of art. Their work, and that of other artists of their caliber, has extended the creative life of the kimono.

The Art-to-Wear Movement led to kimono-inspired artistic production in the West. Such pieces have been worn as clothing or displayed on walls, illustrating that the scope of the kimono has broadened well beyond that of a national costume.

See also **Japanese Traditional Dress and Adornment.**

### BIBLIOGRAPHY

- Asian Art Museum of San Francisco. *Four Centuries of Fashion: Classical Kimono from the Kyoto National Museum*. San Francisco: Asian Art Museum, 1997.
- Dalby, Liza Carihfield. *Kimono: Fashioning Culture*. New Haven, Conn.: Yale University Press, 1993.
- Gluckman, Dale Carolyn, and Sharon Sadako Takeda. *When Art Became Fashion: Kosode in Edo-Period Japan*. New York: Weatherhill, 1992.
- Ishimura, Hayao, and Nobuhiko Maruyama. *Robes of Elegance: Japanese Kimono of the 16th–20th Centuries*. Raleigh: North Carolina Museum of Art, 1988.
- Kennedy, Alan. *Japanese Costume: History and Tradition*. Paris: Editions Adam Biro, 1990.
- Kyoto National Museum. *Kyoto Style: Trends in 16th–19th Century Kimono*. Kyoto: Kyoto National Museum, 1999.
- Liddell, Jill. *The Story of the Kimono*. New York: E. P. Dutton, 1989.
- Peebles, Merrily A. *Dressed in Splendor: Japanese Costume 1700–1926*. Santa Barbara, Calif.: Santa Barbara Museum of Art, 1987.
- Stevens, Rebecca A. T., and Yoshiko Iwamoto Wada, eds. *The Kimono Inspiration: Art and Art-to-Wear in America*. Washington, D.C.: The Textile Museum, 1996.
- Stinchecum, Amanda Mayer. *Kosode: Sixteenth–Nineteenth Century Textiles from the Nomura Collection*. New York: Japan Society and Kodansha International, 1984.

Alan Kennedy

**KLEIN, CALVIN** Calvin Klein was born in the Bronx, New York, on 19 November 1942. He attended the High School of Industrial Arts and the Fashion Institute of Technology in New York, where he studied fashion design.

Klein's first major position in the fashion industry was with Dan Millstein, a Seventh Avenue coat and suit manufacturer. He worked there from 1962 to 1964, starting as a pattern cutter and advancing to a full-fledged designer.



**Billboard featuring Calvin Klein underwear.** A visually striking and sexually charged advertising campaign helped make Klein's underwear line a huge success. © BETTMANN/CORBIS. REPRODUCED BY PERMISSION.

Klein's second position was with Halldon, Ltd., where he began to be recognized in the press for his designs.

Klein soon became frustrated by the design restrictions of moderate-priced fashion manufacturers. Encouraged by his parents and financed by his boyhood friend Barry Schwartz, Klein developed a collection of coats and suits under his own label.

Klein's first line was discovered by a buyer from Bonwit Teller, who was so impressed by the collection of finely tailored coats in fresh colors that he sent Klein to meet with Mildred Custin, then president of Bonwit Teller. Custin placed a large order with Klein, giving a jumpstart to the newly formed Calvin Klein Limited.

Early on, the savvy Klein developed relationships with fashion insiders, including the designer Chester Weinberg and *Vogue* fashion editor Nicolas de Gunzburg. The publicity agent Eleanor Lambert took Klein on as a client and was instrumental in guiding his early career. Klein's first *Vogue* cover was in September 1969, with his classically cut outerwear featured prominently in the New York fall preview editorial inside. Throughout the 1970s, Klein's designs were noted for their sportswear influence, muted pastel color palettes, and simplicity of design. Looks that are considered classic Klein were introduced at this time: the pea coat, the trench coat, the shirtdress, and the wrap blouse. Klein was also an early advocate of all-occasion or "day into night" dressing, with evening pajamas being his preferred form of formal wear.

As the decade wore on, Klein eased up his tailoring for a relaxed, sexy look. Klein also began to incorporate looks from active sportswear into his collection—

swimwear and tennis outfits that could be used off the beaches and tennis courts by pairing them with wrap skirts or pants. Corduroy cargo pants, flannel shirts, and elegant fur-trimmed parkas were shown on Klein's 1970s fall runways. For all his innovations, Calvin Klein won his first Coty American Fashion Critic's Winnie Award—as the youngest recipient ever—in 1973. He won again in 1974, and in 1975 he was inducted into the Coty Hall of Fame. In 1978 Klein began designing a menswear collection that was licensed to Maurice Biderman.

The most groundbreaking piece of sportswear Klein showed on the runway first appeared in spring 1976: a slim-cut pair of jeans with his name embroidered on the back pocket. Although the idea of logo-embellished jeans was not brand-new, this was the first time that jeans had shown up on a designer runway. By 1978, with Puritan Fashions as manufacturer, Klein was selling 2 million pairs of jeans per month. The phenomenal success that Klein had with his jeans line was due in no small way to a brilliant and controversial advertising campaign starring a young Brooke Shields.

### The 1980s

Klein's designs, even in the excessive 1980s, continued to evoke a minimalist aesthetic, with a relatively restrained use of embellishment and color. The core of the collection was, as always, made up of timeless pieces in good fabrics. The Council of Fashion Designers of America (CFDA) recognized Klein when he won designer of the year awards in 1982 and 1983 for his women's collection. Klein won a CFDA award in 1986 for both his men's and women's collections, the first time a designer had won both awards in the same year.

In 1982 Calvin Klein launched a men's underwear line. The collection revolved around a standard men's



"I didn't think I was doing anything different from what *Vogue* did when it used Brooke as a model. . . . *Vogue* put \$3,000 dresses on her, but it wasn't expecting to sell those dresses to 15-year-olds. It was using her as a model and I was using her as an actress" (Quoted in Plaskin, p. 4).

With the Brooke Shields ads, Calvin Klein forever changed television commercials. Klein spent an unprecedented \$5 million on marketing that year. Feminists were enraged by the jeans ads and felt that, rather than sales, the commercials—with slogans such as "You know what comes between me and my Calvin's? Nothing"—would provoke violence against women (Plaskin, p. 62).

brief, with Klein's name stamped on the waistband. Bold black-and-white photography on the packaging and an advertising campaign featuring celebrity models Antonio Sabato Jr. and Marky Mark in suggestive poses helped make the product appealing to both straight and gay men. The underwear line became a phenomenon when Klein took the same briefs and modified and marketed them for women. Warnaco purchased the underwear division in 1994.

By 1983 Calvin Klein, whose eponymous fragrance had produced a lukewarm reception four years earlier, was ready to give perfume another try. The result was *Obsession* and, again, with brilliant advertising—television ads directed by Richard Avedon and print ads shot by Bruce Weber—*Obsession* was a success. In 1986 Klein married Kelly Rector, one of his design assistants. The marriage, as well as the mid-1980s “return to family values” mood, inspired the designer's next fragrance, *Eternity*. A shared-gender fragrance, *cK One*, was launched in 1994.

### The 1990s

In the 1990s Calvin Klein's worldwide expansion into Asia, Europe, and the Middle East markets brought his name international consumer recognition. The decade also saw Klein revamp the jeans/sport division of the company, creating the *cK* collection, made to appeal to a younger, hipper customer. Klein had been farsighted enough to realize the importance of archiving his work, so a constant recall of his roots was readily available. The *cK* line, largely inspired by these vintage collection pieces, was recognized by the CFDA with an award in 1993.

Klein surrounds himself with people who share his aesthetic, and he is known in the fashion world for his intensely collaborative relationships with those who work with him. Most noteworthy is Zack Carr, who was Klein's creative doppelgänger for almost thirty years. Jeffrey Banks, Isaac Mizrahi, and Narciso Rodriguez are also notable Calvin Klein alums.

The twenty-first century began with litigation between Klein and Warnaco over underwear and jeans distribution. The case was eventually settled out of court. Klein and his partner Barry Schwartz sold Calvin Klein, Inc., to Phillips-Van Heusen in December 2002. Since that time Klein has stepped down as creative head of the company that bears his name and has assumed a consultant role.

The name Calvin Klein represents so many different things—controversial advertising campaigns, the leading name in the designer-jeans phenomenon, stylish boyish underwear for women, and brilliant and ruthless business practices. So much of what Klein designed has become fundamentally what Americans wear that his clothing can rightly be called an American uniform.

See also **Avedon, Richard; Brands and Labels; Vogue.**



**Calvin Klein.** Considered one of the most prominent American designers, Klein launched his own clothing company in 1968, and rapidly became known for his line of designer sportswear. AP/WIDE WORLD PHOTOS. REPRODUCED BY PERMISSION.

### BIBLIOGRAPHY

- Carr, George. *Zack Carr*. New York: Power House Books, 2002.
- Gaines, Steven, and Sharon Churcher. *Obsession: The Lives and Times of Calvin Klein*. New York: Carol Publishing Group, 1994.
- Horyn, Cathy. “The Calvinist Ethic.” *New York Times Magazine*, 14 September 2003, 64–69.
- Marsh, Lisa. *House of Klein: Fashion, Controversy, and a Business Obsession*. Hoboken, N.J.: John Wiley and Sons, 2003.
- Plaskin, Glenn. “Calvin Klein: The Playboy Interview.” *Playboy*, May 1984.
- Reed, Julia. “Calvin's Clean Sweep.” *Vogue*, August 1994, 236–241.

Gretchen Fenston and Beth Dincuff Charleston

**KNICKERS.** See **Panties.**

**KNITTING** Knitwear pervades people's everyday lives; it has been estimated that one in five garments worn worldwide are knits. While comprising an essential part





**Man in knitted hat.** Bolivian *chullos* (caps) such as this are knitted with a very fine gauge wool, allowing for very distinctive and intricate pattern work. © HUBERT STADLER/CORBIS. REPRODUCED BY PERMISSION.

of the industrial manufacture of clothing, knitting is also a widespread leisure practice with a burgeoning literature. The titles of some publications of the late 1990s and early 2000s on the subject—*Hip to Knit*, *Zen and the Art of Knitting*, *The Urban Knitter*, *The Knitting Sutra*—suggest that in addition to being a craft and an expressive art form, knitting is also a lifestyle.

### Techniques, Tools, and Materials

Knitting is the formation of a textile from interlocking loops (stitches) of yarn. Each stitch on a horizontal row is locked into the stitches above and below, creating a durable, pliable fabric that has been used for clothing across the world over centuries. Knitwear's elasticity enhances fit, and its structural properties of absorbency and insulation render it highly functional. Additionally, the fact that the knitter may choose from hundreds of stitches and work with multiple colors offers an aesthetic richness that has led to knitwear becoming a creative, expressive form of dress.

Knitting is formed by hand with needles or by machine. It can be created in flat-shaped pieces that are then sewn together, or worked in the round. Hand knitters have used a variety of needles, usually of metal, through sometimes of wood, bone, bamboo, ivory, and, in the twentieth century, plastic. Needles typically have pointed ends, though in some countries, such as Portugal, they are hooked. The circular needle became increasingly popular during the twentieth century. This double-ended needle with a flexible central section is used for knitting tubular pieces, but also affords greater comfort for flat knitting, as the weight of the fabric rests in the knitter's lap. Sets of smaller double-ended needles are commonly used for knitting socks or for areas with a small circumference.

Although some of the earliest knitted artifacts have been discovered in Egypt, knitting has predominantly been developed in colder climates. The most common yarn has been wool, though some exceptionally fine early pieces were knit in silk. Cotton as a less elastic yarn has not been as popular a choice for hand knitters. The explosion in availability of artificial yarns and blends during the twentieth century offered knitters unprecedented choice of materials, and some of the most innovative design has resulted from the exploitation of the structural properties of these yarns and the surface manipulation of knitted textiles.

The way the knitter holds the yarn varies by region. In America and Great Britain, the yarn is carried in the right hand and thrown over the right needle; the left is used in continental Europe. In some areas, such as the Shetland Isles off the north coast of Scotland, one needle is anchored in a sheath. In Turkey, Greece, Portugal, Peru, and Bolivia, the yarn is often looped around the neck to create tension.

### History

Knitlike structures dating from the later Roman period were long thought to be the earliest extant examples of hand knitting. However, it has been determined that these pieces were made by the nalbinding method, which was practiced in Scandinavia, Africa, and other areas to make socks, gloves, bags, and even dancers' costumes. Nalbinding produces a textile resembling a knit with a single sewing needle and short lengths of yarn.

The earliest surviving true knits are Islamic socks dating from 1200 to 1500, discovered in Egypt and often decorated with bands of ornamental Arabic script, and a meticulously crafted pair of thirteenth-century cushions recovered from a royal Spanish tomb. Medieval knitting was often associated with the church; there are even a number of late medieval and early Renaissance paintings that depict the Madonna knitting. In Britain, more utilitarian applications included cap-making—a flourishing and well-regulated industry.

The Englishman William Lee invented the first hand-operating knitting frame in 1589, in response to

consumer demand for imported silk stockings. He was denied a patent because of fears over the machine's impact on the hand-knitting trade. Subsequent advances enabled fabric to be produced in the round (early machines produced flat-shaped work requiring seaming), as well as with complex patterning, and use of multiple colors. But it took many centuries to produce on a machine what a skilled hand-knitter could produce on four or more needles. In fact, only as recently as 1998 was a completely seamless panty-hose product first produced.

In continental Europe, knitting guilds played an important part in regulating the industry, some of them surviving into the eighteenth century. Knits began to assume a significant role in import/export economies. During the sixteenth century, the male fashion for short full trunk hose inspired the import into Britain of expensive silk stockings from Spain, worn to display shapely legs to advantage. By the next century, wool stockings were exported from Britain to Germany, France, Italy, and Holland. While hosiery had been a mainstay of the knitting industry, other garments types such as shirts and jackets were being produced.

Despite mechanization, the hand-knitting industry continued to thrive; hand knitting could of course be executed with the minimum of equipment, at home, and between other work, and was a convenient means of supplementing income from rural industries. It was a craft practiced by women, men, and children, and could provide relief during periods of economic hardship.

Imperialism exported forms of European administration to the colonies, and also knitting. The example of Kashmiri weavers who adapted shawl motifs into knitted caps is a famous illustration of the hybridization of traditions. In America, schools were established to teach children to knit—for profit and to encourage probity—with hands and minds occupied in learning a craft, the apprentices were less likely to misbehave. By the American Civil War, knitting for soldiers became an expression of patriotism, repeated during both World Wars as well.

During the twentieth century, knitwear became an arena in which avant-garde designers experimented and excelled. It has also been a mainstay of street wear from the clinging garb of the 1950s' sweater girls to the puffed cardigans of the next decades, to the ubiquitous sweat suits of the early 2000s.

### Regional Traditions and Social Significance

Hand knitting has played an important role in regional economies, especially in Great Britain and Europe. Embedded as it is in the lives of local communities, the practice is rich in social significance. Many traditions have developed in response to the occupational and climactic needs of a region's inhabitants. The best known of these include the guernseys (or ganseys or jerseys), knitted for fishermen around the coasts of the British Isles. This piece of clothing is knitted in the round on the body and

sleeves and in rows on the upper torso to create a seamless garment. Typically dark blue, the guernsey makes virtuoso use of juxtapositions of knit and purl, creating rugged, utilitarian structures that aesthetically delight. Knit stitches are formed with yarn held to the back, and the loops are drawn upward, creating an appearance of vertical rows; purl stitch is created with the yarn held to the front, and the loops drawn to the face of the fabric, creating horizontal ridges. As fishing is a peripatetic occupation, and as fishermen took wives from different regions, it is fruitless to tie motifs to specific districts. What initially started as production for family consumption developed during the nineteenth century into a contract business for a much wider market, further disseminating motifs. The patterns of the guernsey reflect the inventiveness of the makers, as well as the non-local nature of the fishing industry and the role of contract work in the local economy.

An offshoot of the Guernsey tradition with a very different history is Aran knitting, produced on the three Isles of Aran off the Irish Atlantic coast. Aran sweaters are knitted in flat pieces, usually in creamy white wool, and make prodigious use of high relief cables whose boldly chiseled forms are reminiscent of ancient Celtic interlacing. It appears, though, that the Aran tradition is a relatively new one, possibly dating back no further than the early twentieth century, and more commonly produced as fashion wear than work wear.

Some regions in Spain, Russia, and the Shetland Isles became significantly known for lace knitting, and home production was often supported by philanthropic efforts to avoid displacement of rural workers. Lace knitting was practiced during the nineteenth century by the Shetland islanders after the decline in demand for mass-produced hand knitting. The fine, silky wool of the Shetland sheep benefited the production of lace shawls so delicate they could be drawn through a wedding ring. Although methods of distribution varied, home production throughout Britain was certainly assisted by the introduction of the Parcel Post in 1840.

Fair Isle, a tiny island to the south of Shetlands, became known for the production of intricate stranded-color knitting. First noted in the nineteenth century, Fair Isle knitting was absorbed into mainstream fashion when the Prince of Wales donned this style for the golf course in 1922. Many countries have stranded-color knitting traditions, and it is difficult to establish a history of precedent and derivative. Established trading between Scotland, Scandinavia, Western Russia, and the Baltic states, and the fact that all these regions have comparable knitting styles, suggests a vibrancy of cross-fertilization rather than the importation of a dominant tradition.

South American countries developed distinct styles of stranded-color knitting, often in imitation of indigenous woven textiles. Intricately patterned Bolivian *chullos*, or caps, knitted with a very fine gauge, are some of

the best known. As with the Shetland Isles, availability of fine wool—in this case alpaca, llama, and vicuña—stimulated this industry. Cooperatives continue to assist South American knitters in the marketing of their work, and it is common to see sweaters from Bolivia and other South American countries for sale in the high street.

A prominent twentieth-century example of the promotion of knitting as a means of economic stimulus was the Bohus Stickning collective, created in Sweden in the 1930s to provide work for the wives of unemployed stonemasons. This company was innovative in its use of trained designers to create garments targeted at a high-end market.

### Fashion Design for Hand Knitting

Despite mechanization of the craft, hand knitting continues to contribute to local economies and also functions as a fast-growing leisure pursuit. Since the 1970s, fashion designers, often trained in universities and art schools, have inspired hand knitters to take a more adventurous approach to texture, color, and construction.

Mary Walker Phillips has been at the forefront of the movement to promote knitting as a fine art, publishing books on innovative stitches and experimental structures. Patricia Roberts has revolutionized the way in which the leisure practice of hand knitting is marketed. Discouraged by the poor yarn selections in stores, she began in 1974 to sell mail-order kits with patterns and yarn. In 1976, she opened a specialized yarn shop in Knightsbridge, London—the beginning of an effort to market her line internationally. The format of her high-quality fashion publications for disseminating her designs has been much emulated.

The designer knitting boom has been fed by improvements in yarn availability for home consumption. In 1978, Stephen Sheard co-founded Rowan Yarns in Yorkshire, England, which in the early 2000s remains a prominent manufacturer of natural fiber yarn in exciting color palettes. Rowan works with some of Britain's most innovative designers such as Kaffe Fassett, originally of California, whose works inspired by Oriental ceramics, kilims, and Indian miniatures demonstrate that even inexperienced knitters may achieve results of lush, glowing color.

Many designers produce for the home knitter, as well as the fashion industry. Examples include Jean Moss, a virtuoso Fair Isle designer who has worked for Laura Ashley and Ralph Lauren; Susan Duckworth, a painter whose early clients included Joseph Tricot; and Martin Kidman, a designer of clever pictorial knits who has worked for Joseph as well.

### Couture and Ready-to-Wear Knits

Certain couturier knits have become design icons—for example, Chanel's jersey-knit suits and Schiaparelli's butterfly-bow trompe-l'oeil pullover. Some design houses have built their oeuvres on knitwear. Missoni, for in-

stance, created its unmistakable striped and zigzag motifs on the family's warp-knitting machinery, previously used for producing shawls. The Benetton company created a niche producing upliftingly colored sweaters and cardigans, often in lambswool, to a mass market.

Some designers have reinterpreted classic knitting traditions. Solveig Hisdal for Oleana transforms Norwegian folk traditions. Jean Paul Gaultier often manipulates the scale of Aran motifs, while Vivienne Westwood jests with argyles and knitted lace. The design house TSE is well-known for fine-gauge intarsia.

Perhaps the most innovative approach to contemporary knitted clothing lies in its construction. Some designers retain a couturier approach to knits, such as John Galliano, who cuts and seams with aplomb. Yohji Yamamoto manipulates garment shapes, playing with reversibility and layering. Hussein Chalayan is master of the trompe-l'oeil, creating garments that deliberately deceive as to their construction. Possibly the most radical in this field is Issey Miyake, whose concept A-POC (A Piece of Cloth) combines mass manufacture with mass customization—a potential revolution for clothing manufacture. A-POC, which has been featured in museum fine art exhibitions, creates clothing modules from enormous rolls of tubular knitted fabric.

The type of technological advance that allowed A-POC has provided fertile ground for fashion designers' experimentation. The mechanization of knitting is a complex and still-evolving subject. Developments in machinery and yarn have been symbiotic; machines are now capable of knitting "yarns" of metal wire and plastic. A further step has been the utilization of processes that permit the surface manipulation of knitted textiles—processes such as heat-bonding, laminating and rubberizing, that tend to explode the boundaries between knits as utility and art.

See also **Crochet; Knitting Machinery.**

### BIBLIOGRAPHY

- Black, Sandy. *Knitwear in Fashion*. New York: Thames and Hudson, Inc., 2002. A well-illustrated survey of knitwear in contemporary designer fashion.
- Keele, Wendy. *Poems of Color: Knitting in the Bohus Tradition*. Loveland, Colo.: Interweave Press, 1995. Explores one example of the role of hand knitting in a regional economy, and discusses a model of manufacture and distribution, in addition to providing much clearly written technical information.
- Macdonald, Anne. *No Idle Hands: The Social History of American Knitting*. New York: Ballantine Books, 1988. Explores knitting as a social practice from the Colonial period to the 1980s.
- Phillips, Mary Walker. *Creative Knitting: A New Art Form*. New York: Van Nostrand Reinhold Company, 1971. Influential argument for knitting as a fine art, with instructions for experimental stitches.



Rutt, Richard. *A History of Hand Knitting*. Loveland, Colo.: Interweave Press, 1987. A comprehensive history of hand knitting with particular emphasis on Britain.

*Vogue Knitting*. New York: Sixth and Spring Books, 2002. A definitive single source for stitches and techniques, and a good brief history.

*Lindsay Shen*

**KNITTING MACHINERY** Knitting machinery is the primary means of producing fabrics by the knitting process outside of the crafts businesses. Mechanical production of knitted fabrics began in England in the sixteenth century with the invention of the circular knitting machine by William Lee. In the 1700s knitting machines were attached to power drives moved by water or wind for the first time and the individual production of knits as a cottage industry began to decline.

The function of an automatic knitting machine is dependent on the design and function of the knitting needles the machine uses. The knitted stitches in the fabric body are identified by component rows of needles. The stitches formed along the yarn feed direction are courses. Those formed along the position of each individual needle are the wales. There are three major categories of knitting needles for automatic machines: spring beard, latch hook, and compound (or bipartite). Each of the needle types is designed so that when it is extended, it contacts a yarn on the lower, or shank, end of the needle. It is retracted to capture the yarn inside a hollow head formed by an outer hook, and forces a previously formed loop of yarn over the outer hook to hold and form a loop with the internally held yarn inside the hook head. As the needle is extended, the internal yarn slides out of the hook interior and the head of the newly formed loop relaxes so that it cannot return into the hook interior, but rather must slide along the shank and over the hook head to capture and form the next loop of yarn in the needle. With the spring beard and latch hook needles all of the actions are entirely passive and require no external activation. The compound needle is machine activated.

Machine knitted fabric types fall into two broad categories: weft knits and warp knits. Weft knits are characterized by the use of one set of feed yarns that form loops on each successive row of previously formed loops in rows that are known as “courses.” They may be produced in either circular or flat form, but require no manipulation of the weft yarns other than by the knitting needles themselves.

Warp knits are fed from warp beams very similar to those mounted on looms, but they do not require the interlacing of weft yarns for fabric formation. Like weft knits, they form interloopings of yarns in courses. Unlike weft knits, they do not interloop individually with themselves but rather require outside manipulation of their paths over or under neighboring knitting needles.

Manipulation of the warp knit yarns is effected by means of needle guide bars that hold eyelet guides used for the major motions of warp knitting—the swing (front to back) and the shog (left to right). The swing and shog motions combine to produce bindings among weft knit yarns in both the wale and course directions and may be altered to produce open, long shogs, tighter, short shogs, reverse side underlaps or looser overlap loops in the structures. These knits may have inlays of yarns that are orthogonal to the warp yarns that are known as weft yarns, but they do not act like the weft yarns in a woven fabric because they are not required for the structure to hold together.

See also **Knitting; Needles**.

#### BIBLIOGRAPHY

Brackenbury, T. *Knitted Clothing Technology*. Cambridge, Mass.: Blackwell Scientific, 1992.

Collier, B., and P. Tortora. *Understanding Textiles*. Upper Saddle River, N.J.: Prentice-Hall Inc., 2001.

Schwartz, P., T. Rhodes, and M. Mohamed. *Fabric Forming Systems*. Park Ridge, N.J.: Noyes Publications, 1982.

Spencer, D. J. *Knitting Technology*. Oxford: Pergamon, 1989.

*Howard Thomas*

**KNOTTING** Knots by themselves are any accidental or intentional entanglement of cord, braid, ribbon, beading, fabric or other material that will create a new shape or structure by forming loops, intertwining, and weaving of the base fabric. The new structure may be used to enhance or accessorize many forms of dress. Simple knots and complex knots can be created using a few simple instructions from craft books. Using cords, beading, braiding, trims, ribbons, or other appropriate flexible material, the knowledgeable designer can enhance the appearance of any simple fabric by forming knots.

Knots are made by folding or twisting the cord over and under the standing part of the original cord. The end used to form the knot is termed the working end and the other part of the cord is the standing part. Cord may be formed into bights (a 180-degree turn with no crossing), loops (a more than 180-degree turn with crossing of the standing part), or combined into more complex shapes (a knot, bend, hitch, weave, braid, or multiple loops and bights) depending on the desired look. Fabrics may be twisted into a rope prior to knotting, whereas when ribbon is used, it is typically formed flat into bows, using bights pulled through the knot instead of pulling through the ends. Beading uses knots between the beads, to ensure that they do not all fall off if the support cord is broken.

Knotting originated with prehistoric humans tying grasses and twigs, and later using sinews, into lashings used to hold together sticks and stones to make tools.

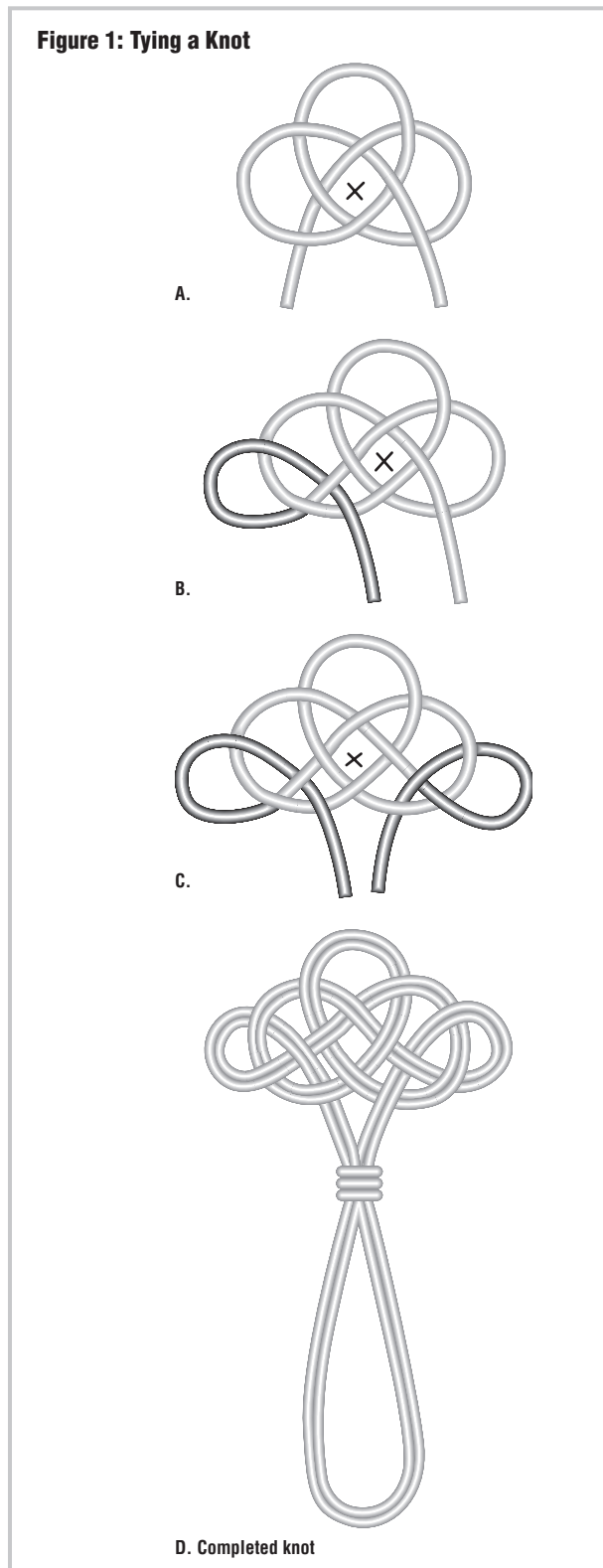

**Knot tying illustration.** Knots can be formed by a variety of materials, from cord to beading. Both simple and more complex knots can be created by referencing instructions in craft books.

Knotting also took on survival significance in the form of knotted garments and woven fencing and roofs to keep out the cold of the Ice Age. Knotting later took on religious and political significance and appeared throughout the world as carvings in stone and wood, in the shape of magical knots and heraldry symbols.

The most well-known form of knotting is macramé. Macramé (from *migramab* in Arabic, which means “coverlet,” or *magrama* in Turkish, which means towel), originated in the thirteenth century in what was then known as Arabia with the tying together of the cords that formed the foundation of the carpets, for which the region was already famed. Macramé work spread from there to Southern France in the fourteenth century, then fell into disuse for several more centuries, until the early part of the nineteenth century. A slightly different form of macramé was also known by sailors in the seventeenth and eighteenth centuries as McNamara’s Lace, a form of pulled-thread canvas work, in which silks and ribbon were fed through in place of the weft and in which the warp threads were knotted together to form patterns of knots, after the weft threads were removed. Warp threads are those that are parallel with the selvage, the vertical edges of a fabric; weft threads are those that cross the warp threads. Sailors would weave these pieces from scraps of twine, ribbon, silk, and rope that they carried in their ditty bags, which were often highly decorated canvas bags made of macramé and McNamara’s Lace combined.

Jewelry of woven gold and silver wire also produced rings, necklaces, anklets, and bracelets in adornment of simple medieval dress, while fancy knotted and braided leather belts were used to hold clothing in place, everywhere from Argentina to Canada and beyond. Knotting took on special significance in East Asian dress, where certain types of knots (usually rather elaborate ones) were considered charms capable of conferring health, wealth and well-being. Knots were used in Korea as adornments of wedding costume (*maedup*), and throughout the region as elements of Buddhist temple decorations and vestments. In Japan, special knots were used as ties to adorn gift-wrapping.

Knotting took the form of free interpretive art with the resurgence of macramé in the 1960s and again more recently with the use of macramé pieces added to enhance the look of retro fashions. European and American dress has moved beyond the look of mesh, netting, and knotted articles to a more demure and international look in knotted shoulder straps, scarves, sarongs, pareos, and sandals, imitating Grecian and South Pacific styles. The elegance of lace and tating also has not been lost to another age, but has seen recent moves to reintroduce these fine woven and knotted fabrics to enhance or highlight evening dress necklines and cuffs. Knots used in the early 2000s include the overhand knot, the Carrick bend, plaiting and braiding, the sheet bend, and the square knot. Knotting’s simplicity and its intrigue add a touch of mys-

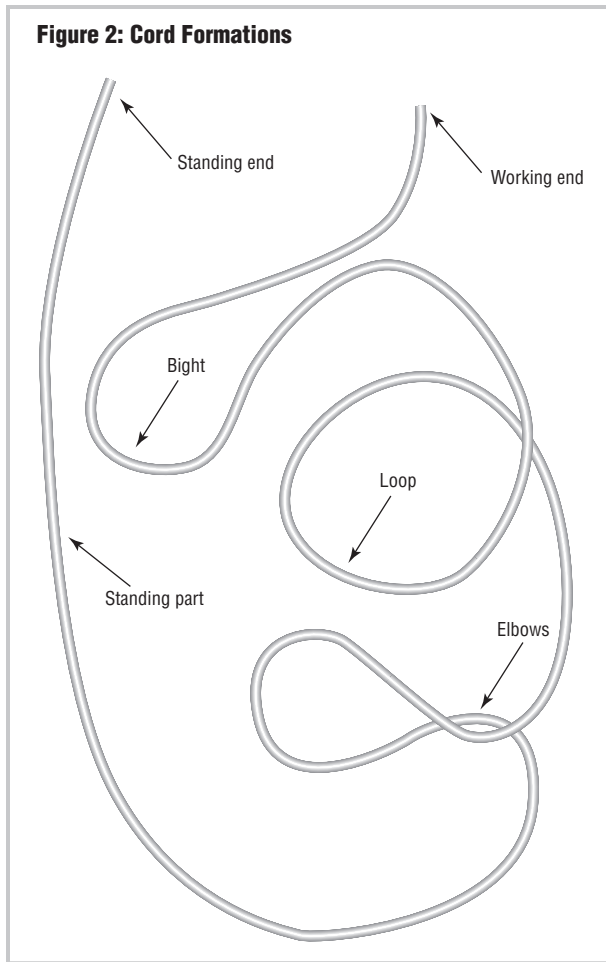

**Cord formations.** Cord can use several forms to create knots, including bights (180° turn, no crossing), loops (more than 180° turn, crossing the standing part), and multiple loops, as well as more complex shapes.

tery and insouciance to a wide variety of forms of modern dress, and accessories.

See also **Braiding; Weaving.**

#### BIBLIOGRAPHY

- L'art des noeuds maedup: Tradition de la parure coréenne dans l'oeuvre de Mme. Kim Hee-jin.* Espace Pierre Cardin, Paris, 10–30 April 1986.
- Ashley, Clifford W. *The Ashley Book of Knots*. 1st ed. Garden City, N.Y.: Doubleday, 1944.
- Budworth, Geoffrey. *The Ultimate Encyclopedia of Knots and Rope Work*. 1st ed. London: Anness Publishing Limited, 1999.
- Graumont, Raoul, and John Hensel. *Encyclopedia of Knots and Fancy Rope Work*. 2nd ed. Centreville, Md.: Cornell Maritime Press, 1939.
- Lammer, Jutta. *The Reinhold Book of Needlecraft*. New York: Van Nostrand Reinhold, 1973.

Rainey, Sarita R. *Fiber Expressions*. Worcester, Mass.: Davis Publications, 1979.

Walkley, Victor. *Celtic Daily Life*. Rowayton, Conn.: Doveetail Books, 1997.

Lindsay Philpott

**KOREAN DRESS AND ADORNMENT** The dress of the Korean people reflects the breadth and depth of their experiences and has resulted in a continuously evolving amalgamation that includes Korean traditions as well as borrowed elements. In the twentieth century, both North and South Korean societies have experienced immense change as a result of the Korean War and the division into South and North Korea. South Korea has experienced rapid industrialization, modernization, and population shifts from rural to urban areas. Provoked by invasions and foreign occupation, South Koreans forged a strong national identity.

During its thirty-five-year annexation, Japan attempted to assimilate the Korean people into the Japanese mainstream and destroy the Korean national identity. Freed from Japanese rule and distanced from their own heritage by almost two generations of occupation, South Korea embraced the culture of their new ally, the United States, following the Korean War, to the extent that any historical customs or ideas contrary to Western culture were seen as old-fashioned and out-of-date, and the traditional culture became the subordinate one. Modernization became the goal, but new values were not securely grafted to those of the traditional. Therefore, while modernization succeeded as an economic and manufacturing goal, it failed as the basis on which to create a new national identity.

In the 1970s, South Koreans realized the necessity of rediscovering their traditional culture to create a unified and identifiable future for their country. Since then, Koreans have been more aware of their traditional values and the symbols that reflect them. They have worked diligently to redefine and reinvent their traditions.

Hobsbawm uses the term “invented tradition” to include both traditions actually invented, constructed, and instituted formally, as well as those emerging in a less traceable manner, but nonetheless establishing themselves within a brief time period. Inventing traditions is a process of formalization and ritualization characterized by reference to the past. “Invented tradition” is defined as “a set of practices, normally governed by overtly or tacitly accepted rules and of a ritual or symbolic nature,” which seek to affirm certain values and norms of behavior by repetition, and automatically imply continuity with the past (Hobsbawm and Ranger, p. 1). In a society such as Korea’s, with so many rapid changes taking place, tradition had become a necessity to provide a sense of integration and unity for individuals.





**Korean women in traditional dress.** While the retention of traditional dress is seen as important to their culture, many Koreans are not averse to the addition of contemporary elements.

© ROBERT HOLMES/CORBIS. REPRODUCED BY PERMISSION.

Korean traditional dress helps Koreans define their traditional values, such as philosophy, religious attitude, and family relationships. But Koreans have not felt a contradiction in the coexistence of traditional values while adopting those of foreign cultures or searching through their own culture for new ways to express their past. The expressed need is to maintain a culture suitable to the Korean circumstance while continuing the rediscovery and rearrangement of the traditional culture. The valuing of tradition is considered not just sentimental but a necessary aspect of Korean culture.

Traditional dress has become a blend from both traditional Korean history and Western elements, and its form and definition are ever changing, but in an evolutionary process. This helps to interpret and enrich the statement of Linnekin that culture is passed on with each generation creatively adding to its construction.

### Traditional Dress Defined

The term Koreans use for traditional dress is *hanbok*, which means “dress of our race,” while *yangbok* is used to

refer to Western dress. These two categories are worn in Korea simultaneously. Though both *hanbok* and *yangbok* have influenced each other, they appear distinct from each other in Korean society.

Korean forms of traditional dress for females and males contain many similarities. When stored flat, the parts are basic rectangular shapes, such as the full skirt of the female and the trouser of the male. The prescribed direction and manner of fastening of the parts of the *hanbok* are very specific. Fabric textures are similar and may be a smooth linen or cotton for everyday and silk or silk-like fabric for ceremony and special events.

Female *hanbok* consists of two main pieces: the full, floor-length skirt, or *chima*, which covers the lower torso and legs, and the *chogori*, which covers the upper torso. The *chima*, made of three widths of fabric gathered onto a two-and-a-half-inch-wide band, wraps tightly around the body directly under the arms and fastens just above the breasts. The middle skirt panel is placed at the center front of the body and wrapped around to overlap and open on the back left side. The tie band is brought around and secured with a front knot to fasten the skirt. The skirt is fitted to the body at the chest area, and the gathers curve from the chest and then fall to the floor.

The *chogori*, worn on the upper torso, has a V-neck and is asymmetrical, with an overlap to tie on the wearer’s right side. The sleeve is a rectangular shape but with a slight curve on the underarm. The neckband, referred to as the *git*, began as a rectangle but has evolved to a curved line. The *dongjung* is a white detachable neckband made of stiff cardboard and wrapped in fabric. It is basted onto the neckband, making it both decorative and easy to replace when soiled. The *otgoreum* is a tie band that closes the *chogori* and, when fastened with a one-sided bow, results in a vertical asymmetric line that trails and extends onto the *chima*. The *norigae* is a hanging ornament, carefully selected as an accessory that attaches to the tie band. It often consists of beads, tassel, or fringe that swings freely when attached to the skirt band and *otgoreum*. A long coat, or *turumagi*, is worn over the *chogori* and *chima* in cold weather.

Traditionally the hair is arranged by pulling it back from the face, and secured in a low knot or chignon for married women or a braid for unmarried women. The resulting small, neat head shape is considered an appropriate and pleasing proportion in contrast with the voluminous skirt. A headdress, once an important aspect of traditional dress, is no longer worn. On the feet are worn padded white socks, referred to as *beoseon*. The padding provides a modified curve that relates to the gentle curves of the rest of the costume. The slipper shoe, *komusin*, is worn over the padded sock and repeats the gentle curve. Historically made of braided rice straw or silk, by the early twenty-first century the slipper was composed of rubber or leather.

Male traditional dress consists of two parts, *paji*, the trousers, and a top, *chogori*. The trousers are cut and sewn



**Korean family in the early twentieth century.** Korean involvement in several world conflicts helped foster a strong national identity, and traditional dress became an important factor in society. © CORBIS. REPRODUCED BY PERMISSION.

from rectangular and triangular shapes. They can be folded flat for storage but are shaped on the body by folding to the right side and fastened with a separate fabric tie. The man's *chogori*, while similar to that of the woman, is longer, with a wider neckband and shorter ribbon tie. It fastens on the right and has a V-shaped neckline, with a curved neckband and white, stiff detachable band similar to the one worn by the female. A vest of contrasting color is worn over the *chogori*, then a jacket over the vest to complete the ensemble. The vest and jacket are often of the same color, but contrast with the color of the *chogori*. A *turumagi* of dark or subdued color is worn outdoors, and a muffler added in cold weather.

Young males and females wear shapes similar to their adult counterparts, but the fabrics used are more intense primary colors and warmer in hue, such as yellow and red. Another age-based difference is seen on a young child who, for a special event such as a first birthday, wears a *chogori* with rainbow stripes on the sleeves.

Traditional colors in Korea are primary ones such as red and blue, but muted in intensity. In contrast to the West, white is the color of mourning, though it is also used for trimming the neck of the *chogori*. Traditional wedding costume is brightly colored, with red for the bride and blue for the groom.

The adoption of certain colors, such as fuchsia or hot pink, resulted from an interaction with Western culture. When Elsa Schiaparelli introduced the color in the 1930s, Koreans discovered that hot pink was flattering to their physical coloring, and thus hot pink was adopted for engagement garb of both young men and women. By the early 2000s, the use of hot pink had come to symbolize the special celebration of the engaged couple.

Some colors are traditionally worn by the elderly or by the married woman with a child, and therefore those colors have become recognized as reflecting the individual wearer and his or her respective status. The use of a color may be identified with a particular year because of

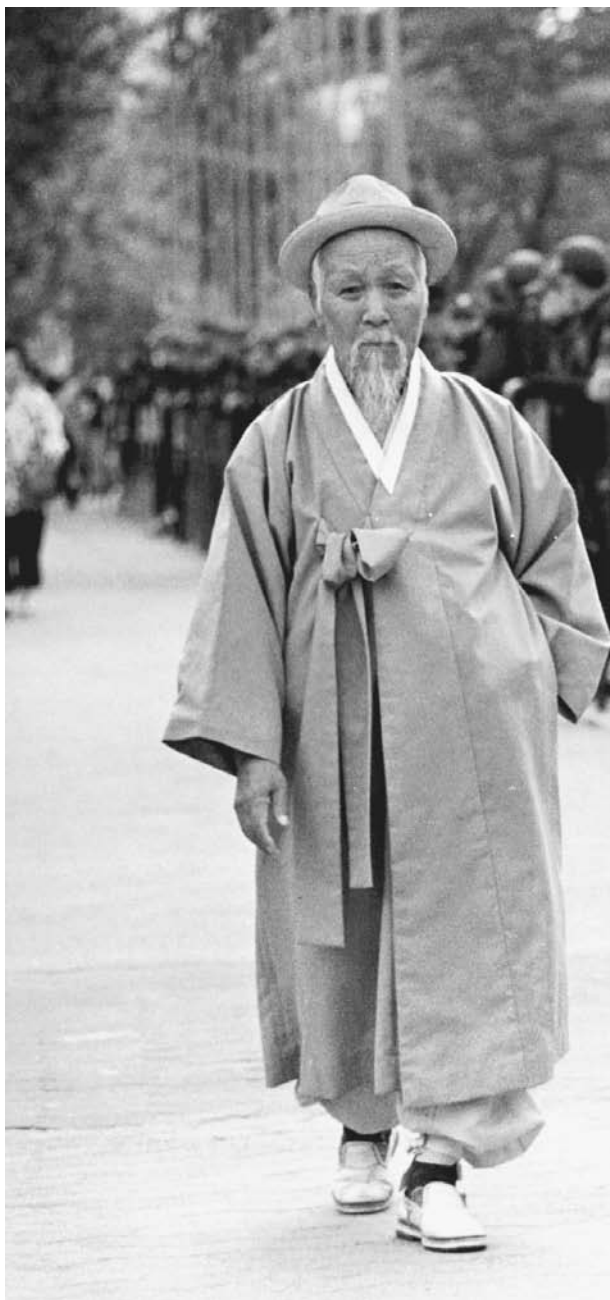

**Elderly Korean man.** Traditional dress in the twenty-first century is more frequently worn by older Koreans, who see it as a symbol of their heritage and value system. AP/WIDE WORLD PHOTOS. REPRODUCED BY PERMISSION.

its popularity. To be valued, Korean traditional dress must be constant in silhouette and details of layout, but have up-to-date colors and design motifs.

Intricately embroidered panels and motifs used on the elaborate wedding attire of the bride and groom are symbolic of Korean history. For example, the phoenix, a mythical bird, may be combined with clouds, animals

such as tigers and deer, or recognizable flower patterns, such as the chrysanthemum. Motifs may become symbolic of cultural values such as long life, or happiness. Many of these motifs originated in China but now have been thoroughly assimilated into Korean culture. Many traditional motifs embedded in Korean history and that were worn by royalty in the past have been adopted by the modern bride or groom and worn as a part of the wedding ceremony. Many ornaments have traditionally been designed to ward off the evil eye. For example, vials of perfume or certain colors have been worn to deflect attention of the evil eye, thus acting to protect the wearer in a symbolic way.

### The Role of Korean Traditional Dress

An observer walking on the streets of Seoul, South Korea, would discover that normal everyday dress is Western, or *yangbok*. There are a few differences when compared to Western dress of other cultures, especially a greater adherence to formality in the appearance of the Korean people. Both men and women in professional positions wear a coordinated suit ensemble, and men adhere to the dark formal business suit, white shirt, and tie for work. Also, because of the physical coloring of the Korean people, certain favorite colors, such as muted golds, browns, and blacks, are often worn. Because the average Korean is small-boned and between five-foot-three and five-foot-seven in height, fit is especially important in the sizing and scale of clothing.

The role of traditional dress in modern Korean society is primarily that of celebration and ritual, with traditional dress most often worn for special occasions such as birthdays, weddings, and other significant events. To serve in a celebratory manner, Korean traditional dress needed to be removed from daily use, as suggested by Hobsbawm. With its use for everyday seen as impractical and not conducive to modern life, historic Korean dress went from being a daily convention to a symbol of the traditional values of the Korean people. For those who continue to wear Korean traditional dress, such as a Buddhist monk or a waitress in a Korean folk restaurant, such modifications make it more wearable for daily use, such as shortening the skirt to ankle length or using washable and durable fabrics. However, some Koreans object to the modifications of traditional dress. Perhaps a modified Korean traditional dress doesn't function as well for celebration because it is more practical and thus loses some of that special celebratory quality.

Traditional dress is a sign and a symbol of Korean culture. To maintain its respected stature within Korean society, some changes in the formal properties of Korean traditional dress are permitted to evolve continuously and yet be perceptible to the informed eye. Shades and hues used for traditional dress may change, but these are not viewed as drastic alterations. Korea's history itself provides much of the justification for change.



Slight variations in detailing and coloration seem to be acceptable in Korean traditional dress, while changes in the silhouette are not so prevalent. The silhouette, shapes, and proportion of the *chogori* and *chima* are what make Korean traditional dress recognizable to Koreans. The neckband and asymmetrical tie are details that remain more fixed. Color is a characteristic that identifies Korean traditional dress with specific events and with an individual's selections. For example, pink is for an engagement dress and blue is a good choice for the mature woman. The use of color identification and change in some detailing does not alter the salient characteristics of silhouette, providing a clue to historical continuity and acceptance.

In Korea, traditional dress is worn to express the country's heritage and values. Korean females place importance upon their traditional dress and appearance and appreciate its symbolic nature. As in many cultures, women are usually the purveyors of culture, the arts, and traditions. The use of Korean traditional dress by females as a source of celebration is indicative of gender difference in upholding cultural traditions. Korean women wear traditional dress to show their love for their country and pride in its unique heritage. Korean males wear traditional dress more sparingly in celebration of life events, such as for a first birthday, weddings, or a sixtieth birthday.

An examination of the role historical dress plays in Korean society can illuminate those aspects that make for traditional character. To instill pride and continuity with the past, the traditional garments need to be perceived as stable, even though changes in color and surface motif do persist. Korean traditional dress changes in subtle ways, yet quite regularly, and thus is accorded a fashionable aspect. When questioned, Korean women will express the need to change their traditional dress every three to five years to keep it fashionable. However, this fashion is not determined by the United States, Paris, London, or Milan, but prescribed by Korean dressmakers and scholars of Korean traditional dress. Designers are constantly working on historic renditions of Korean traditional dress that help to interpret the past and then seem to trickle down from a couture house to being more widely available through a dressmaker or department store.

Perceptions of Korean traditional dress are a function of country of residence and age. For example, Koreans living in America have a somewhat different perspective about traditional dress than Koreans living in Korea. Age is a factor in defining perceptions of Korean traditional dress. The younger person is more accepting of modified forms and variety in wearing. These perceptions highlight the amount of change that had occurred in the late 1990s and early 2000s. However, changes in traditional practices of Koreans who live in both the United States and Korea do not seem to signify a lack of respect for traditional habits, but rather, a change in lifestyle.

Peoples of other countries use forms of traditional dress derived from their past that similarly communicate their unique history and culture. In a country where traditional and Westernized components can coexist within the same objects of tradition, its people can draw upon the influence of both. The resiliency of the Korean people has enabled a unique national character to remain paramount, while foreign elements simultaneously become deeply fused to a strong cultural base.

### Present Uses of Korean Traditional Dress

Korean traditional dress has been an enduring aspect of Korean culture, historically worn every day by men, women, and children. While it is not unusual to see the elderly man or woman in traditional dress on a daily basis, the younger man or woman restricts its use to more special occasions, and unmarried youths may not wear it at all. While most men rarely dress in traditional garb, the practice of wearing it is far more prevalent for Korean women; still, evidence exists that conventions and routines are changing based upon age and other cultural ties such as marital, economic, or maternal status. With its use primarily restricted to ceremonial occasions, Korean traditional dress is still surrounded by rules of etiquette: who should wear what, how to wear it, and when it should be worn.

Certain occupations require traditional dress for everyday wear, but usually as a symbolic gesture. Those who represent the Korean culture to foreign countries often wear traditional dress. The wife of the president, flight attendants, and even the elevator operator in an international hotel in Seoul may wear traditional dress as a symbol of their country's characteristic dignity and grace.

While traditional dress remains a valued part of Korea's history, to be highly valued it also must appear fashionable. Although traditional dress by definition would seem to demand invariance, in Korea, traditional dress changes quite regularly—but in subtle ways—and is thus accorded a fashionable aspect.

See also **Ethnic Dress; Ethnic Style in Fashion.**

### BIBLIOGRAPHY

- Cho, Kyu-Hwa. *Aesthetics of Costume*. Seoul: Soohack Sa., 1986.
- Covell, Jon Carter. *Korea's Cultural Roots* 3d ed. Salt Lake City: Moth House Publications, 1982.
- DeLong, Marilyn. *The Way We Look: A Framework for Visual Analysis of Dress*. New York: Fairchild, 1998.
- DeLong, Marilyn, and Key Sook Geum. "A Systematic Analysis of the Aesthetic Experience of Korean Traditional Dress." In *ITAA Special Publication Number 7*. Edited by Marilyn R. DeLong and Ann Marie Fiore. Monument, Colo.: International Textile and Apparel Association, 1994.
- Geum, Key Sook. "A Study of the Korean Aesthetic Consciousness through the Choson Costume." Ph.D. diss. Ehwa Women's University, Seoul, 1988.

- Geum, Key Sook, and Marilyn DeLong. "Korean Traditional Dress as an Expression of Heritage." *Dress* 19, no. 5 (1992): 57–68.
- Hobsbawm, Eric, and Terence Ranger, eds. *The Invention of Tradition*. New York: Cambridge University Press, 1983.
- Huh, Dong-Hwa. *Crafts of the Inner Court*. Seoul: The Museum of Korean Embroidery, 1987.
- Il-sung, Park, et al. *The Identity of the Korean People*. Seoul: Research Center for Peace and Unification, 1983.
- In, Dong-Hwan. *A Study on the Korean Folklore*. Seoul: Dongmyoung-moon-wha Sa., 1973.
- Kahng, Hewon, and AeRan Koh. "Effect of Design Modification and Color Scheme on Impression Formation of Traditional Korean Women's Clothing." *Journal of the Korean Society of Clothing and Textiles* 15, no. 2 (1991): 211–227.
- Kim, Jin-Goo. "Korean Costume: An Historical Analysis." Ph.D. diss., University of Wisconsin, 1977.
- Linnekin, Jocelyn. "On the Theory and Politics of Cultural Construction in the Pacific." *Oceania* 62, no. 4 (June 1992): 249–263.
- Morse, Ronald A., ed. *Wild Asters: Explorations in Korean Thought, Culture and Society*. Washington, D.C.: Asia Program, Woodrow Wilson International Center for Scholars; New York: University Press of America, 1987.
- Park, Kyoung-ja, and Soon-Young Im. *Korean Clothing Construction*. Seoul: Soohack Sa, 1981.
- Suk, Joo-Sun. *The History of Korean Costume*. Seoul: Bojinjae, 1971.

*Marilyn Revell DeLong and Key Sook Geum*



**LABELING LAWS** For thousands of years, people only had natural fibers to care for and use. But with the explosion of manufactured fibers, blends, and finishes after World War II came confusion. Manufacturers gave their own products trade names that meant very little to consumers. A real need for more information was provided in the form of a series of labeling laws.

#### **Ruling on the Weighting of Silk**

In its natural state, silk has a gummy feel, and it is usual practice to remove the gum. In so doing, however, the weight of the silk is greatly reduced. To counter that loss, in the late nineteenth century, manufacturers began the weighting of silk to counteract the weight lost by degumming raw silk. Silk was subjected to metallic salts, which could be absorbed in quantities greater than the weight of the silk itself. While the immediate result was a fabric with a heavier hand, the long-term effect was to create a fabric that tended to split into shreds. Since the consumer had no way of discerning this, the U.S. Federal Trade Commission (FTC) ruled in 1938 that silk weighted more than 10 percent and black silk weighted more than 15 percent must be labeled *Weighted Silk*. While this ruling remained in effect in the early twenty-first century, few silk items were weighted by then.

#### **Wool Products Labeling Act**

According to this act, most products that contain any amount of wool must be labeled by the name of the wool source and percentage weight, even if it is less than 5 percent. They must distinguish between wool (also known as “virgin wool” and “new wool”) and recycled wool, wool from a textile product that has been returned to a fibrous state and remade into a different product. The manufacturer’s name or number registered with the FTC must be on the label as well as (since 1984) the country of origin.

Some products, such as hats and slippers that contain some wool, must be labeled under this labeling act even though they are exempt under the Textile Fiber Products Identification Act (TFPIA). The following items, when made of wool, are exempt from the provisions of this act: carpets, rugs, mats (though these are covered by the TFPIA), upholsteries, and wool products destined for export.

In the early days of this act, the FTC assigned Wool Products Labeling (WPL) numbers to particular manufacturers or retailers of wool. Since each company would retain its number forever and some manufacturers have changed their products’ fiber content from wool to such nonwool fiber as polyester, some nonwool products have a WPL number.

#### **Fur Products Labeling Act**

Fur fibers that have been removed from the animal’s skin are subject to the rules set forth in the Wool Products Labeling Act and the TFPIA. Labeling of fur fibers attached to the skin is regulated by the Fur Products Labeling Act. The labels must contain the animal’s species and may include the adjective form of the country (such as *Russian Mink* or *Canadian Fisher*). Labels must also provide the name or registered number (RN or WPL) of the manufacturer, importer, or other distributor. The country of origin must be given. If the fur has been colored, pointed, or bleached, the label must state this. If the fur has not been so treated, it should be labeled as *Natural*.

#### **Flammable Fabrics Act**

The original act banned the use of highly flammable materials for clothing. In 1967, the law was amended to include highly flammable household textiles. Further amendments have banned the use of all flammable materials for carpets, draperies, mattresses, upholstery, and children’s sleepwear (sizes 0–14). Standards for each of these products may be found on the Web site of the Federal Trade Commission ([www.ftc.gov](http://www.ftc.gov)).

#### **Textile Fiber Products Identification Act**

The TFPIA requires that the name of the fibers (natural, such as cotton, or the generic name for manufactured fibers, such as nylon) be listed in descending order by percent weight of the total. If fibers are present in quantities of less than 5 percent, they should be listed as other fiber(s). If several fibers constitute less than 5 percent each, they should be combined and listed as other fibers, even if their combined total is greater than 5 percent. Two exceptions exist: because of the Wool Products Labeling Act, all products containing wool must be listed, even if the percentage is less than 5 percent. Also, those



products that provide a definite functional property in amounts of less than 5 percent may be listed as such without explaining what the functional significance is. Small amounts of spandex lend a good deal of stretch to a garment, for example.

Pile fabrics can list fibers by total weight only. However, if a label lists fibers as *100% nylon pile, 100% cotton back*, the label must also add the fibers by weight: *60% cotton, 40% nylon*; in other words, the back is 60 percent of the fabric and the pile is 40 percent. Those fibers composed of two or more chemically distinct fibers must be listed as biconstituent or multiconstituent.

The manufacturer's name or registered identification number (RN or WPL) must be given. Consumers can find out the name of the company by going to the FTC Web site ([www.ftc.gov](http://www.ftc.gov)), clicking on Business Guidance, and then RN Lookup Service.

The country of origin must be listed. Products made entirely in the United States of materials from the United States must be labeled *Made in USA*. Products made in the United States of imported materials must be labeled as such: *Made in USA of Imported Fabric*. The country name for imported items must be written in English, but may be written in additional languages as well. The country of origin information must always be on the front of the label.

All of the required fiber information may be put on one tag or several as long as the information is legible, conspicuous, and accessible to the consumer. All content information must be in the same size print. Other extraneous information may be included on the fiber label as long as it is not misleading to the consumer.

### Care Labeling Rule

The Care Labeling Rule of 1972 set down very specific requirements for manufacturers and importers to follow. In 1984, the rule was amended to provide a Glossary of Standard Terms. In 1999, the American Society for Testing and Materials developed care symbols intended to be understandable around the world, despite language differences. In 2000, the Care Labeling Rule was amended again. In the early 2000s the rule requires that care instruction apply to the entire garment.

According to the Care Labeling Rule, textile clothing and piece goods (fabric sold to home sewers) must carry a care label outlining safe cleaning procedures. In the case of clothing, a care label should be sewn into the garment and be easily viewed at the time of purchase. It should remain legible for the lifetime of the garment. For completely reversible garments with no pockets and for other garments where a label would ruin their appearance (such as a sheer blouse), care information may be put on a hang tag. For clothing sold to institutions such as hospitals, no label is needed, but care instructions must be given to the institution at the time of purchase. Textiles that can be cleaned safely in several ways are re-

quired to list only one method. For items that can be cleaned by the harshest methods, the label should read, *Wash or Dry Clean, Any Normal Method*. This means that the item could safely be machine-washed in hot water, bleached with any bleach, tumble-dried hot, and ironed at a hot setting. It also means that the item could be dry-cleaned using any solvent. For items that cannot be safely cleaned by any means, the label should read, *Do Not Wash—Do Not Dry Clean*.

Washing instructions include five elements, outlined below:

*Washing.* The label must say if hand-washing or machine-washing is recommended. Also, unless the product can be washed in hot water, a temperature must be specified.

*Bleaching.* If any available bleach can be used without harm, the label need not mention bleach. If chlorine bleach would damage the product, the label must say, *Only Non-Chlorine Bleach, When Needed*.

*Drying.* The label must indicate how the product should be dried: tumble dry, dry flat, or drip dry. If the product cannot be machine-dried at the hottest setting, then the proper temperature must be stated.

*Ironing.* Ironing information is required if ironing will be needed on a regular basis. If ironing cannot be done at the hottest setting, a proper temperature must be specified.

*Warnings.* Special warnings must be given if a consumer might reasonably use a care procedure that would result in damage. A delicate garment suitable for hand-washing might need a *Do Not Wring* warning. Products that might damage other items washed with them might need warnings such as *Wash Separately* or *Wash with Like Colors*. Warnings do not need to be used for alternative care procedures. If the label reads, *Machine Wash Cold*, it need not use the warning *Do Not Wash in Hot Water*.

If garments can be safely dry cleaned with any solvent and there are no special conditions that require warnings, then the label may say, *Dry Clean Only*. These garments can be put in a dry-cleaning machine by the consumer at a Laundromat or given to a professional dry cleaner. When a warning is needed, it should be stated after the words *Professionally Dry Clean*. For example, if steam would cause damage, the label should read, *Professionally Dry Clean—No Steam*.

See also **Dry Cleaning; Fibers; Fur; Silk; Wool**.

### BIBLIOGRAPHY

- Collier, Billie J., and Phyllis G. Tortora. *Understanding Textiles*. 6th ed. Upper Saddle River, N.J.: Prentice-Hall, 2000.
- Humphries, Mary. *Fabric Reference*. 3rd edition. Upper Saddle River, N.J.: Prentice Hall, Pearson Education, 2004.

### Internet Resources

- "Care Labeling of Textile Wearing Apparel and Certain Piece Goods, as Amended, Effective September 1, 2000." U.S.

Federal Trade Commission. Available from  
<<http://ftc.gov/os/statutes/textile/carelbl.htm>>.

“Clothes Captioning: Complying with the Care Labeling Rule.” U.S. Federal Trade Commission. Available from  
<<http://www.ftc.gov/bcp/conline/pubs/buspubs/comclean.htm>>.

“Threading Your Way through the Labeling Requirements under the Textile and Wool Acts.” U.S. Federal Trade Commission. Available from <<http://www.ftc.gov/bcp/conline/pubs/buspubs/thread.htm>>.

*Elizabeth D. Lowe*

**LABOR UNIONS** Clothing industry workers, severely exploited during most of the nineteenth century in countries at the forefront of the industrial revolution (such as Great Britain, France, Germany, and the United States), made powerful efforts to form effective trade unions during the latter part of the century. The initial stages of unionization saw the creation of numerous separate unions, which tended then to go through a process of amalgamation in order to increase membership and bargaining power. This process can be seen very clearly in the case of Great Britain, for example, where by the beginning of the twentieth century, clothing workers' unions included the Amalgamated Society of Journeymen Tailors, the Amalgamated Union of Clothiers' Operatives, the Amalgamated Jewish Tailors, Pressers and Machinists' Trade Union, the London Clothiers Cutters, the Shirt, Jacket and Overall Workers, and the Belfast Shirt and Collar Workers. These joined together to form the United Garment Workers' Union (UGWU) in 1912. The UGWU subsequently added other unions, including the Scottish National Association of Operative Tailors, the London Operative Tailors, and the Amalgamated Society of Tailors and Tailoresses. With the merger in 1931 of the UGWU with the United Ladies Tailors (London) and the Waterproof Garment Workers Union, the amalgamated union changed its name to the National Union of Tailors and Garment Workers. In the United States, The United Garment Workers of America (UGWA) was organized in 1891, incorporating several earlier independent unions; the more radical Amalgamated Garment Workers Union (AGWU) broke away from the UGWA in 1914. The International Ladies Garment Workers Union was founded in 1900. Textile workers, less concentrated in urban areas, were slower to unionize; the Textile Workers Union of America was organized in 1939, and later merged with the AGWU. Similar processes of organization and amalgamation marked the history of garment and textile workers unions in the countries of Western Europe.

Once a potent force in the textile and apparel industries, labor unions have been on the decline in the post-World War II period in many parts of the world, including Central and Eastern Europe, Central America, the United States, and Europe. Among the reasons for

this decline are employer resistance or anti-unionism, the increasing power of multinational corporations, inadequate statutory protection for unions and union organizing in developing countries, and the inadequacy of unions to respond quickly and efficiently to labor issues. The long-term history of the garment and textile industries has been for production to move from high-wage to low-wage (which usually means from union to nonunion) countries, or regions within countries; this poses a severe challenge to labor unions in the field.

Globalization of textile and apparel production along with the dislocation of workers from industrialized countries to developing countries have meant that unions have had to reach across national boundaries to create linkages among workers for this sector. For example, members of the Union of Needletrades, Industrial and Textile Employees (UNITE) have worked through its International Trade Secretariat to organize workers and to address basic worker rights and working conditions in Central America and the Caribbean.

Internationalization of the labor movement is not a new phenomenon; it began in the late nineteenth century in Europe. Stimulated by the economic and political conditions of various countries, such as industrial growth, increased international trade, and more competitive world markets, workers in industrialized nations became apprehensive about working conditions in developing countries and sought “to establish minimum labor standards by international agreement” (Lorwin, p. xii).

The demand for international labor standards after World War I resulted in the establishment of the International Labour Organization (ILO) in 1919 under the League of Nations. The ILO became a specialized agency in the United Nations in 1946. Through a series of conventions and recommendations, labor standards to be attained worldwide were set forth by this organization. In 1998, the ILO organized a tripartite meeting for government, employer, and worker representatives to exchange views on labor practices in the textile, apparel, and footwear industries. Its report addresses labor issues concerning workers' rights to freedom of association and collective bargaining, the elimination of child labor and forced or compulsory labor, and the end of gender discrimination with respect to employment and occupation. The representatives engaged in a social dialogue about these issues.

### **International Labor Organizations**

**ICFTU.** The International Confederation of Free Trade Union's regional organizational affiliates are found in Asia and the Pacific (APRO-Asia-Pacific Regional Organization), Africa (AFRO-African Regional Organization), and the Americas (ORIT-Inter-American Regional Workers' Organization). They act as channels of communication and maintain linkages with the European Trade Union Confederation and the Global Union Federation, of which the

International Textile, Garment, and Leather Workers Federation (ITGLWF) is one of ten members.

It brings together more than 200 affiliate organizations in more than 100 countries. Affiliates include UNITE in the United States and Canada, KFAT—the National Union of Knitwear, Footwear and Apparel Trades in the United Kingdom, and the BTGLWF—Bangladesh Textile, Garment and Leather Workers Federation.

Operating as an integral part of the ITGLWF are its regional organizations in Africa, Asia, Europe, and the Americas. The issues that are addressed with its regional organizations and affiliates include: (1) the elimination of forced and child labor; (2) the promotion of occupational health and safety standards; (3) the participation of women in worker-employer dialogues, especially home workers in the informal sector as well as workers in the export processing zones in different countries; and (4) the encouragement of social responsibility by multinational manufacturers, merchandisers, and retailers. It works closely with the ICFTU, the ITUs, and nongovernmental organizations (NGOs).

### UNITE Formed

In 1995, the International Ladies Garment Workers Union and the Amalgamated Clothing and Textile Workers Union merged to form the Union of Needletrades, Industrial and Textile Employees (UNITE) in the United States. They joined forces to provide strength for collective bargaining and a voice concerning domestic and international labor issues. Since its inception, UNITE has been involved with: (1) initiating “Stop Sweatshop” campaigns to bring attention to working conditions in New York, California, and South America; (2) assisting university students in forming United Students Against Sweatshops—an organization to keep universities from selling garments made under sweatshop conditions; (3) demanding that labor standards be enforced in global trade agreements with developing countries during trade talks; (4) challenging retailers to improve working conditions and observe workers’ rights in factories making their clothes; and (5) promoting the visibility of the “Made in the USA” label to help retain textile and apparel jobs in America. These and other activities help UNITE to fulfill its goals; that is, to bring workers together, to protect members’ work contracts, to prepare a workers’ agenda or a list of things to be accomplished, and advocate against sweatshops, nationally and internationally. In Canada, UNITE has more than 25,000 members and has called attention to its sweatshops and home workers which mostly employ women workers.

### Summary

Garment and textile workers unions have responded to changing economic, social, and political conditions throughout the world by emphasizing international organization and cooperation. The issues that led to the

formation of strong garment and textile workers unions in the industrialized world of the nineteenth century remain important throughout the world, and can only be addressed on an international level and with reference to the international labor standards promulgated and upheld by the ILO. In addition, NGOs, such as the Clean Clothes Campaign, the National Labor Committee, and the Women Workers Worldwide, have been established to draw further attention to labor issues worldwide. Unions face continuing challenges to organize industrial workers in developing countries, and to reach into informal sectors of production in many parts of the world, sectors in which women’s and child labor continue to be exploited.

See also **Globalization; Sweatshops.**

### BIBLIOGRAPHY

- Clete, Daniel. *Culture of Misfortune: An Interpretive History of Textile Unionism in the United States*. Ithaca, N.Y., and London: Cornell University Press, 2001.
- Gordon, Michael E., and Lowell Turner, eds. *Transnational Cooperation among Labor Unions*. Ithaca, N.Y., and London: Cornell University Press, 2000.
- Lorwin, Lewis L. *The International Labor Movement: History, Policies, Outlook*. New York: Harper, 1953.
- Nissen, Bruce, ed. *Unions in a Globalized Environment: Changing Borders, Organizational Boundaries, and Social Roles*. Armonk, N.Y., and London: M. E. Sharpe, 2002.
- O’Brien, Robert. “Workers and world order: The tentative transformation of the international union movement.” *Review of International Studies* 26 (2000): 533–555.
- Windmuller, John P. *International Trade Secretariats: The Industrial Trade Union International*. Foreign Labor Trends Report. Washington, D.C.: U.S. Department of Labor, Bureau of International Labor affairs, 1995.

### Internet Resources

- International Labour Office. *Business and Social Initiatives Database, 1996–2003*. Available from <[http://www.oracle02.ilo.org/dyn/basi/upisearch.first?p\\_lang=en](http://www.oracle02.ilo.org/dyn/basi/upisearch.first?p_lang=en)>.
- . *Codes of Conduct and Multinational Enterprises*. Available from <[http://www.ilo.org/public/english/region/europro/london/download/fp3\\_4.pdf](http://www.ilo.org/public/english/region/europro/london/download/fp3_4.pdf)>.
- . *Labour Practices in the Footwear, Leather, Textiles and Clothing Industries*. Report for discussion at the Tripartite Meeting. Geneva: International Labour Organization. Available from <<http://www.ilo.org/public/English/dialogue/sector/techmeet/tmlfi00/tmlfir.htm>>.
- International Textile, Garment and Leather Workers’ Federation. *About the ITGLWF*. Available from <<http://www.itglwf.org/displaydocument.asp?DocType=Background&Index=110&Language=EN>>.
- . *ITGLWF Affiliates*. Available from <<http://www.itglwf.org/displaydocument.asp?DocType=Background&Index=68>>.
- UNITE: *A New Union With a Long History*. Available from <<http://www.uniteunion.org/research/history/unionisborn.html>>.



United Nations Association of the United States of America.  
*Internet Resources: Worker Rights in the Global Economy, 1999–2000.* Available from  
 <<http://www.unausa.org/links/gpp99link.asp>>.

*Gloria M. Williams*

**LACE** Lace has played a role in fashionable dress ever since it was developed in the sixteenth century. Loosely defined, lace can be any nonwoven, light, openwork fabric, but in historical terms it was created using two tools: the needle and the bobbin. Both techniques were time-consuming and required great skill. As a consequence, lace was extremely expensive. During the seventeenth

and eighteenth centuries, when lace became an essential element of fashionable dress, the European courts spent great sums of money to acquire the finest examples. Because of this demand, new techniques were continually developed to make lace production less costly and time consuming. Unfortunately, when machine lace finally came into production in the nineteenth century, lace lost its allure and it developed into just another fashion fabric, often used in lingerie, bridal wear, and evening wear.

#### **Needle and Bobbin Lace Origins**

Before needle and bobbin lace developed in the sixteenth century, the term lace referred to the cords that laced sep-



**Lace flounce.** This lace piece was created using the needle and bobbin technique developed in the sixteenth century. Though this method produced lovely, unique garments, it was extremely difficult and time intensive. SECTION OF A BOBBIN-MADE LACE FLOUNCE. BRUSSELS, 1760s. LINEN. COOPER-HEWITT, NATIONAL DESIGN MUSEUM, SMITHSONIAN INSTITUTION. GIFT OF RICHARD GREENLEAF IN MEMORY OF HIS MOTHER, ADELINE EMMA GREENLEAF, 1950-121-45.



**Model wearing lace dress and cape.** While handmade lace continued to be produced in the twentieth century, machine lace was more widely available, and several famous designers of the period began to use it in their collections. © CONDÉ NAST ARCHIVE/CORBIS. REPRODUCED BY PERMISSION.



arate parts of a garment together, such as the sleeves to the shoulders, or to close the back of a bodice. The cords were made in a variety of methods, including the use of bobbins to braid the threads. The term also referred to braided tapes of metallic thread that often trimmed military uniforms. This use of the word “lace” in this context continued into the eighteenth century, when it also described the woven bands that trimmed servant’s livery and the furnishings found in coaches and other vehicles.

During the sixteenth century, the term “lace” found another meaning when it came to refer to bobbin-made insertions that were becoming increasingly fashionable for trimming the undergarments and household furnishings of the wealthy merchants and aristocrats of the renaissance. An insertion was a narrow band that seamed together two pieces of a garment. Like the cords or laces mentioned above, the insertions were placed between the shoulders and the sleeves, and at the shoulder seams. The bobbin technique was adapted to make these narrow flat bands with delicate openwork designs. While linen was often used to make the bobbin lace insertions, colored silk and gold- and silver-metallic thread were also employed.

Embroiderers also adapted their techniques to create insertions. Needle lace, which had its origins in cutwork, an embroidery technique in which a small square of cloth was cut away and the resulting hole filled with a structure created with needle fillings, or buttonhole stitches, became a popular technique for creating insertions. These insertions, constructed in between the grid left after square sections of the base cloth were cut away, had designs with snowflake delicacy and were referred to as *reticella* or *rosette*. *Reticella* insertions were often stitched between the seams of household furnishings, such as table covers, as well as linen undergarments that were becoming an increasingly important component of fashionable dress. *Reticella* and other forms of cutwork also stood alone or were worked into shirts and shifts, creating the elaborate cuffs, collars, and ruffs seen in portraits of the Elizabethans and their European counterparts. As fashions changed during the last decades of the sixteenth century, the rigid geometry of cutwork was replaced with more free-flowing designs. These were first created by cutting larger squares out of the base cloth and later by developing a new method of creating a base structure to hold the buttonhole stitches in place. Instead of cutting squares out of a ground cloth, narrow tapes or thread were laid on a pre-drawn pattern, and buttonhole stitches were then used to fill in the spaces between the tapes or thread, and thus true needle lace was born.

### Lace as Fashion Essential

As bobbin lace, cutwork, and needle laces became more sophisticated, they developed into essential fashion accessories. During the late sixteenth and two succeeding centuries, lace collars, cuffs, borders, ruffles, and headdresses were *de rigueur* for anyone with fashionable pretensions. While most European nations developed some

form of lace industry, the two most important early centers were Venice and Flanders.

Venice developed into one of the first great lace centers during the sixteenth and early seventeenth centuries. Free-flowing designs based on delicate floral vines became popular and were inspired by the textiles and other decorative arts of the countries with whom Venice traded, such as Turkey and China. The second important area for the lace trade was Flanders, where an important linen embroidery trade existed during the sixteenth century. The Flemish supplied small linen and metallic bobbin lace edgings, needle lace edgings, and cutwork, along with embroidered linens. By the seventeenth century, the Flemish became well known for their light, delicate bobbin laces.

Both the Venetian needle laces and the developing Flemish bobbin laces were well suited to new fashions of the seventeenth century that favored flat band collars instead of standing ruffs. Fashionable dress also began to feature softer, lighter fabrics, such as satins and taffetas, as opposed to the heavy velvets of the previous century. Dark colors predominated and provided a suitable surface on which to display the increasingly refined bobbin and needle laces.

In seventeenth-century France, lace became extremely important among Louis XIV’s courtiers and, because of France’s fashion dominance, thus all the courts of Europe. Courtiers wore flat band collars of heavy Venetian lace that showed off beautifully against the lavish fabrics then in fashion. French courtiers spent huge sums of money, most of which left France for Italy and Flanders, to prepare for obligatory visits to Versailles. Eventually Louis and his finance minister, Colbert, despaired of the large sums of money being spent on foreign lace, and they established a lace industry in France. They brought lace makers from Flanders and Italy to France and settled them in select towns including Sedans, Argentan, Valenciennes, and Alençon. These towns developed distinct styles of lace that are still identified by the names of the towns in which they were made.

By the end of the seventeenth century, fashion again impacted the lace industries as a preference grew for lighter, airier laces. The thicker needle laces of Venice went out of fashion and the bobbin laces of Flanders and the new French centers began to take prominence. One of the reasons for this change was the increasing importance of ruffles that were used to decorate the shirtfronts and cuffs of men’s clothing and the skirt fronts, necklines, petticoats, headdresses, and sleeves of women’s dress. Complete lace ensembles were made at extraordinary cost and worn by the elite of Europe into the eighteenth century. The 1764 probate inventory of Mme. de Pompadour, mistress of Louis XV, lists many lace accessories, including a set of Argentan-needle lace accessories for a *robe de chambre* that included dress trimmings, sleeve ruffles, stomacher, neck ruffles, and a cap. The set was



valued at 3,000 French pounds, more than a set of seven buttons set with yellow diamonds and rubies that was valued at 2,600 French pounds.

Lace remained an important fashion accessory throughout the eighteenth century, although by the last quarter, designs had begun to simplify and lace with simple net grounds patterned with small floral vines became particularly fashionable. This simplification in the design of lace occurred at the same time that changes in consumerism and technology impacted the fashion and textile trades. Increasing numbers of people aspired to fashionable dress and acquired the means to afford it. This increase in demand coupled with the simplification of design led to the exploration of techniques of production to bring down the cost and the time involved in its manufacture. Along with the development of new machines to spin yarns and weave fabrics, those at the forefront of the industrial revolution experimented with ways to create machine-made nets and laces.

While lace remained a luxury good, available to few men and women before the late eighteenth century, its subsequent history is one of expansion throughout the social classes and an increasing identification with femininity. As men's clothing moved away from the colorful fabrics and luxurious accessories of the previous centuries and democratized with the development of the three-piece wool suit, lace, ribbons, and trims became the purview of women's fashion. Lace developed into a purely feminine fabric that, because of advances in technology, became widely used in lingerie, evening wear, and as accessories. The invention of machine techniques, the increasing development of new hand techniques by which to create lacelike fabrics, such as embroidered nets, crochet, and tape lace, and decreasing expectations among consumers led to lace and lacelike fabrics' widespread availability. Fine laces continued to be made, especially in Brussels, where needle, bobbin, and combination laces and lace accessories were produced. Centers in France were also celebrated for their lace, especially Chantilly, which became famous for its fine black bobbin lace accessories, such as shawls, fan leaves, and parasol covers.

Despite the continued production of handmade laces, the real story of nineteenth-century lace is the development of fine machine laces that could compete with the handmade ones. The first lace machines, developed during the eighteenth century, actually produced fine net, which was then hand-embroidered to resemble lace. It was not until the early nineteenth century, when the jacquard was attached to the net machines, that patterns became possible. Improvements to the earliest lace machines, such as the Pusher and Leavers machines, continued throughout the century. Soon machine lace could compete with some of the finest handmade laces, and lace became available to almost anyone interested in wearing it.

By the middle of the nineteenth century, when lace became a standard fashion element and no longer a lux-

ury good, a renewed interest in historic laces began. Those who could afford to started to collect historic laces and put together large collections of examples dating from the sixteenth through the eighteenth centuries. Some, like Mrs. J. Pierpont Morgan, would use their historic laces to trim their Worth gowns and would have stood out from their peers who were wearing mechanically produced laces. Other women restyled historic laces and made them into collars, cuffs, and other fashionable nineteenth-century accessories.

The interest in historic laces at the end of the nineteenth century also led to a revival of handmade lace. Italy, in particular, became a center for training young girls in needle and bobbin techniques. Schools such as Amelia Ars and the Burano Lace School taught young women to reproduce many designs from the past, especially the Renaissance. Their work was so good, that it continues to fool collectors in the early 2000s.

### Lace in the Twentieth Century

Craftspeople and artists continued to make lace into the twentieth century. It was taught at art schools in Austria, Germany, Denmark, and Czechoslovakia, where designs followed the then current early-twentieth-century art movements, such as Wiener Werkstaette and the German Secession. By the middle of the twentieth century, artists began to explore the artistic potential of lace, and large hanging sculptures and hangings were made.

While artists and craftspeople continue to explore handmade lace techniques, the twentieth century is the time in which machine lace emerged as a true fashion fabric. Machine lace borders made with the Raschel, Leavers, and Pusher machines were incorporated into many fashionable dresses of the first three decades of the twentieth century. Floral and geometric designs were most common. However, novelty laces also became popular. Clowns, Greek maidens, and even one of Columbus's sailing vessels (used to commemorate the 400th anniversary of his voyage to the Americas) were incorporated into lace designs and could be found trimming women's skirts, bodices, and lingerie. During the 1920s and 1930s bolts of machine lace were produced and became a fashionable fabric out of which designers such as Gabrielle Chanel began to construct luxurious evening dresses. Lace continued to be used as a fashion fabric throughout the twentieth century, enjoying popularity during the 1950s, and again in the 1980s.

Lace continues to enjoy a place in fashionable dress and especially in lingerie. Its light, delicate, feminine qualities make it a fashion perennial, even into the twenty-first century, when the September 2003 issue of *Harper's Bazaar* proclaimed lace "fashion's most romantic fabric" (p. 364) and dedicated the fashion spread to current designs exploiting its seductive potential.

See also **Embroidery; Lingerie.**

## BIBLIOGRAPHY

- Levey, Santana. *Lace: A History*. London: Victoria and Albert Museum and W. S. Maney and Son, 1883.
- Levey, Santana, and Milton Sondag. "Contact, Crossover, Continuity: The Emergence and Development of the Two Basic Lace Techniques." In *Contact, Crossover, Continuity: Proceedings of the Fourth Biennial Symposium of the Textile Society of America*. Earleville, Md.: Textile Society of America, 1994.
- Pfannschmidt, Ernst-Eric. *Twentieth-Century Lace*. New York: Charles Scribner's Sons, 1975.
- Sondag, Milton. *Lace in the Collection of the Cooper-Hewitt Museum*. New York: Cooper-Hewitt Museum, 1982.

Pamela A. Parmal

**LACROIX, CHRISTIAN** The creations of Christian Lacroix embody in spectacular combinations his Provençal roots, his passion for folklore, and his fascination with the history of clothing. His artfully unexpected mixtures express a new form of luxury, simultaneously youthful, baroque, and sophisticated. Lacroix mingles bright tones and extravagant materials in creations that express a refined blending of different cultures; distant and forgotten costumes form the basis, if not the *raison d'être*, for his work.

Christian Marie Marc Lacroix was born in 1951 in Arles, France. In early childhood Lacroix showed a flair for design by putting together little albums on theater and opera, collages assembling family portraits, and reproductions by Christian Bérard. He left his native Arles to study the history of art in Montpellier, and then enrolled at the Sorbonne in Paris in 1973. He wrote a master's thesis on French costume in the paintings of the seventeenth century while at the same time taking courses at the École du Louvre to become a museum curator. It was at this time that he met his future wife, Françoise Rosensthiel; they married in 1974.

With the encouragement of his wife, he soon turned to fashion design. In 1978 he joined Hermès, where he learned the technical aspects of the profession. Two years later he was an assistant to Guy Paulin and then succeeded Roy Gonzales as a designer for Jean Patou in 1981. In 1986 he received the Golden Thimble award for dresses designed in honor of his native region of Camargue. In December 1986 Lacroix met Bernard Arnault, chief executive officer of the multinational luxury firm Louis Vuitton Moët Hennessy (LVMH), who offered him the financial support needed to open his own couture house.

The Christian Lacroix house was inaugurated in 1987 at 73, rue du Faubourg Saint-Honoré in Paris. On 26 July 1987 Lacroix presented his first collection under his own name, and that year the Council of Fashion Designers of America awarded him the prize for Most Influential Foreign Designer. Inspired by dresses in the style of the 1880s, he designed an off-the-shoulder dress

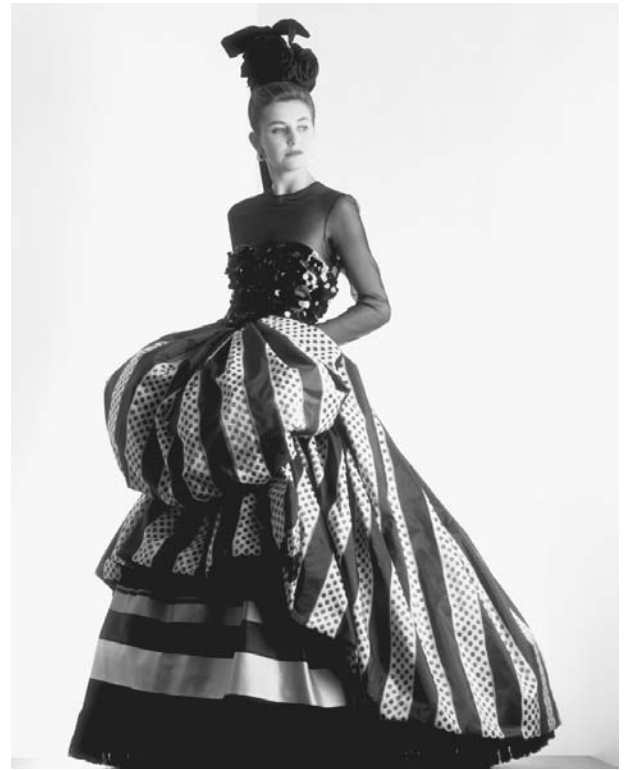

**Model in Christian Lacroix ensemble.** Lacroix's creations were full of whimsy and opulence, and they often featured his trademark pouf. © JULIO DONOSO/CORBIS SYGMA. REPRODUCED BY PERMISSION.

with a high waist, the miniskirt of which became the emblematic "pouf." Completed by a short bolero jacket, the ensemble was cut in highly colored and decorative fabrics inspired by Provence. Folk and traditional elements were set off by a certain French grandeur, coquettishness, and whimsy that reflected the desires of a new generation hungry for luxury. Lacroix's style thus confirmed the taste for a typically southern opulence, instilling new life into French haute couture, which had been stigmatized as a dying art. *France Soir* described Christian Lacroix as the "Messiah," and *Time* featured him on its cover. In 1988 the profession awarded him a second Golden Thimble. The dream collapsed with the stock market crash. The pouf soon became a metaphor for the excesses of the 1980s, which gave way to the minimalism of the 1990s.

In his designs, Lacroix nevertheless remained faithful to his roots and his history in a clothing collection where east meets west, the north basks in the southern sun, and the past blends with the future. The 1980s had allowed him to define and focus these influences, and over the years he continued to quote from and vary his sources of inspiration, as he developed and refined them.

Lacroix also carried on using a glittering palette of colors. "Colors I have always liked, so much so that when

I was a child, I dreamed of swallowing tubes of yellow and vermilion paint," he said (de Bure, p. 129). His designs became more abstract and the dresses more simplified, their architecture more apparent. Previously, the decoration had been designed before the dress; now it came into play only after the dress had been constructed. "In reality, I love only what veers off course, has a defect, is heterogeneous, transitory," he said. "I think I love everything and its opposite. That is probably the key" (du Bure, p. 130).

Lacroix has turned his fashion world into a stage, designing for more than twenty ballets, operas, and plays. In 1996 he was awarded the Molière for best costume design for the Comédie Française production of *Phèdre*. In 2000 he signed a new contract with LVMH, the owner of his couture house. He divides his time between his responsibilities as artistic director of this couture house and his own company, XCLX. The list of his projects is long and varied and his commissions ever more spectacular. Among his extravagant designs are eight carriages of the TGV Méditerranée (a high-speed French train), which he "dressed" and presented as haute couture creations. "This is what now interests me: going beyond fashion to participate in ways of living, in our global environment, with uniforms [for Air France], seats for the TGV, stage costumes. Each of these areas—clothing, theater, design ... helps me to express a facet of my personality" (Bréabant, p. 61). Spectacle is inherent to his vision: "The Lacroix woman is staged in a theatrical fashion. She is not afraid of being noticed; for her one can imagine nothing that is bland (Alessandrini, p. 22).

In 2002 Lacroix was named artistic director of the Florence ready-to-wear house Emilio Pucci. That year he was awarded the medal of Chevalier of the Légion d'Honneur. Lacroix describes French haute couture as "eternally dying and paradoxically constantly being reborn from its ashes" (Sausson, p. 6). A great defender of couture, Lacroix does not conceive of it as an art but rather as a service rendered to his clientele: "Art is something made for love. Art is what makes life more beautiful. Something that motivates and inspires. My work has a purpose; it is not just made for the sake of it" (Lowthorpe, p. 14). His creations, brought into being by a wide range of craftsmen, knitters, corsetieres, painters, and embroiderers, overwhelm and plunge the spectator into a world located between dream and reality, where fantastic textures rival embroidered materials in elegance, where fluid fabrics wedded to richly colored costumes speak in a flamboyant vocabulary signed Christian Lacroix.

See also **Art and Fashion; Ballet Costume; Haute Couture; Paris Fashion; Pucci, Emilio; Theatrical Costume.**

#### BIBLIOGRAPHY

- Alessandrini, Marjorie. "Christian Lacroix: La mode est un théâtre." *Le nouvel observateur*. 12–18 July 2001, p. 22.
- Bréabant, Frédéric. "Christian Lacroix relance la Puccimania." *Weekend le Vif/L'Express*, 28 February 2003, p. 61.

de Bure, Gilles. "Christian Lacroix, l'homme qui comble." *Tech-nikart* 28 (December 1998): 129.

Lowthorpe, Rebecca. "Christian Lacroix." *Independent on Sunday*, 1 July 2001.

Sausson, Damien. "Christian Lacroix, au-delà de la beauté." *L'œil*, September 2000, p. 6.

Pamela Golbin

**LAGERFELD, KARL** Karl Lagerfeld was born on 10 September 1938 to a wealthy family in Hamburg, Germany. He moved to Paris in 1952 and first came to the attention of the fashion world two years later when he won a competition prize for his design of a woolen coat. In 1954 he was hired as a design assistant by Pierre Balmain, one of the premier couture houses of the early post-war period. In 1958 he parted ways with Balmain and became art director at the House of Patou, where he remained until 1962. For most of the next fifteen years he designed for a number of companies and under a variety of contractual and freelance agreements.

He was associated especially with Chloë (1963–1983), where he created styles that simultaneously were elegant and focused on the young. Many of his most striking designs for Chloë had an art deco flavor, being very streamlined and body conscious. He also utilized prints to excellent effect. At the same time, he worked as a freelance designer for Krizia, Valentino, Ballantyne, and other companies. Beginning in 1965 he designed furs for Fendi. His ability to design simultaneously for several different houses has been a defining characteristic of his career; Lagerfeld became known as a man who was never content to do just one thing at a time.

In 1975 Lagerfeld formed his own company and in 1983 became artistic director of the House of Chanel. While continuing his responsibilities at Chanel and at Fendi, he formed Karl Lagerfeld S.A. and KL to market his own ready-to-wear lines. Karl Lagerfeld S.A. was acquired by Dunhill (the parent company of Chloë) in 1992, and Lagerfeld returned to Chloë at that time and held the post of chief designer until 1997, when he was replaced by Stella McCartney. When he left Chloë, he regained control of the company bearing his own name; in the early 2000s Lagerfeld was designing for Karl Lagerfeld/KL, Chanel, and Fendi. He has also designed costumes for many films and theatrical productions.

Lagerfeld probably is most admired for his work at Chanel, where in 1982–1983 he took over responsibility for a company that had become somnolent, if not moribund, and very quickly made it exciting again. Taking the basic vocabulary established by Coco Chanel, he modernized it, introducing new materials, including denim, and exaggerating such details as the "double C" logo. Remarkably, his work for Chanel has remained as vital in the twenty-first century as it was in the mid-1980s.



Karl Lagerfeld has had a wide-ranging career in the arts, achieving considerable success as a writer and photographer. Over the years he has produced many fashion photography spreads for his collections at Chanel and for his own labels and has published several books of his photographs. He also is well known as an aesthete and connoisseur of art and antiques. In 2000 he sold part of his antique furniture and art collection at auction for more than \$20 million. With his signature silver-white hair and newly slim figure, he is a familiar and iconic presence on the European fashion scene.

See also **Balmain, Pierre; Chanel, Gabrielle (Coco); Paris Fashion; Patou, Jean.**

#### BIBLIOGRAPHY

- Buxbaum, Gerda, ed. *Icons of Fashion: The Twentieth Century*. New York: Prestel, 1999.
- Lagerfeld, Karl. *Karl Lagerfeld: Off the Record*. Göttingen, Germany: Steidl, 1994.
- . *Dreams*. New York: Te Neues, 2002.
- Milbank, Caroline Rennolds. *Couture: The Great Designers*. New York: Stewart, Tabori, and Chang, 1985.

John S. Major

**LANG, HELMUT** Helmut Lang (1956–) was born on 10 March 1956 in Vienna, Austria. When he was three years old, his parents divorced; he then lived with his grandfather, who worked as a shoemaker in a village near Salzburg. Lang first took commercial courses at a local trade academy before he switched over to fashion design. Lang opened his first studio in 1977, when he was twenty-one years old, and designed T-shirts and jackets. He soon started to specialize in avant-garde fashion; by the mid-1980s, his women's ready-to-wear collections had become well known in his home country. He launched his first catwalk show in Paris in 1986, nine years after the opening of his first atelier. His minimalist approach was labeled as deconstructionist and avant-garde. In 1987 he also began to design men's wear, and promoted an essentially pure urban style. After Lang's success in Paris, he divided his time between his design studio in Vienna and his consulting agency in Paris. Lang was appointed professor of fashion design at Vienna's Universität für Angewandte Kunst, a college-level institution for the applied arts, in 1993.

Lang's core brand was the Helmut Lang Men's and Women's Collections. The brand was extended in 1995 with the addition of Helmut Lang underwear and shoes, followed by Helmut Lang jeans in the following year, as well as Helmut Lang protective eyewear and accessories. The designer achieved a high level of recognition through these extensions of his brand. He moved to New York in 1998 in order to get an international reputation in the fashion world and entered into a collaborative relationship with the Italian luxury brand Prada in 2000. Lang also launched his first perfumes in 2000.

Lang's minimalist approach was also apparent in his marketing strategy. The best example was the appearance of his Internet web page in the early 2000s. At first glance, a visitor might have thought that the designer's web domain was under construction. The page was almost completely empty; several small links provided access to his current ready-to-wear collections for women and men, accessories lines, store information, press images, and perfumes. Lang's marketing created a set of futuristic images. For example, his web page for women's perfumes featured a series of distinctive phrases in large capital letters that scrolled rapidly past the visitor's eyes: I walk in—I see you—I watch you—I scan you—I wait for you—I tease you—I breathe you—I smell you on my skin. His advertising was also minimal, with simple product shots that appeared surprisingly clean and therefore remarkable. Lang tried to make the reader "breathe" the fashionable quality in his advertising. The caption for an advertising campaign for Helmut Lang Eyewear read, "To promote an intellectual and fearless appearance," showing a "mug shot" of a model's face. While other brands put the designer himself in the foreground to promote collections, Lang avoided attracting attention to himself. When Lang was asked in an interview what his label represented, he replied, "It says Helmut Lang on it. Everything I know is in it." His catwalk shows were presented in a clean, urban minimalist style. In fact, his 1998 collection was shown only over the Internet instead of being displayed in a physical setting.

Claire Wilcox's introduction to *Radical Fashion* described Helmut Lang clothing at its simplest, as defined by a sophisticated interpretation of utilitarian wear. His clothes certainly resembled a uniform for urban living in the early twenty-first century. Lang had a preference for combining unusual materials: he blended cheap materials with expensive fabric, recycled fabrics with high technology. The fabric combinations varied from shiny to matte; they were often a mixture of natural fibers and synthetics. Lang sprayed silver and black varnish on denim in his 2000 collection, transforming basic utility into futuristic objects. His designs did not appear loud, but clearly reflected an androgynous style. A clinical look resulted from a mixture of deconstructionist and classicist forms that united contradictory elements. In "Imagining Fashion," Alistair O'Neill suggested that Lang's work could be understood as an attempt to liberate repressed attributes by concealing them under the supposedly unreadable surface of clothing. O'Neill took the advertising "Man in a Polyester Suit" as an example of Lang's suggestion that the surface of clothing is unreadable. O'Neill suggested that the phallic quality of the image reverberated in subsequent Lang campaigns, but it was the tension between the standard exterior and spectacular interior that came to the fore.

Although the era of minimalist fashion design ended in the early twenty-first century, Helmut Lang still used minimalist codes in his designs. His androgynous ap-

proach to fashion mirrored the clear distinctions between male and female dress in traditional clothing. Lang was stereotyped as the “King of Fashion Minimalism.” It is true that the concept was as important to him as the clothes themselves. This concept was also reflected in his color palette, which mixed noncolors with flashy shades to produce a futuristic effect.

See also **Brands and Labels; Fashion Advertising; Fashion Marketing and Merchandising; Jeans; Unisex Clothing.**

#### BIBLIOGRAPHY

O'Neill, Alistair. “Imagining Fashion—Helmut Lang and Maison Martin Margiela.” In *Radical Fashion*. Edited by Claire Wilcox. London: V & A Publications, 2001.

Wilcox, Claire. *Radical Fashion*. London: V & A Publications, 2001.

#### Internet Resource

Helmut Lang Website. 2004. Available from <<http://www.helmutlang.com>>.

*Thomas Hecht*

**LANVIN, JEANNE** Jeanne Lanvin (1867–1946) was born in Paris, France, and spent much of her youth as a seamstress and millinery apprentice. In 1883 she was employed to trim hats in the workshop of Madame Felix at 15, rue du Faubourg Saint-Honoré. Lanvin established her own millinery workshop at the age of eighteen in 1885. With just forty francs in cash and three hundred francs in credit, Madame Lanvin opened her millinery house in a modest apartment at 16, rue Boissy-d'Anglas in 1889.

Lanvin married the Italian aristocrat Emilio di Pietro in 1895. Although their marriage was brief, ending in 1903, the union produced a single child, Marguerite Marie-Blanche, who was born in 1897. This child inspired and supported one of the greatest design careers of the twentieth century. In 1907 Lanvin married Xavier Melet, a journalist. Lanvin's daughter married for the second time in 1925; her husband was the comte Jean de Polignac, and she became known as Marie-Blanche, comtesse de Polignac.

#### History of the House

In 1908 Lanvin opened a children's clothing department in the millinery shop, inspired by the wardrobe created for her own daughter, and just one year later she opened departments for ladies and girls as well. Becoming a full-fledged *couturière*, she joined the Syndicat de la Couture, the ruling body of the haute-couture industry. Her first dress designs followed the lines of the chemise frock, a long, slender, empire-waist design that offered ease of movement. By 1910, a mere two years after opening her children's department, her designs appeared in *Les modes*, a French fashion periodical.

By 1925 twenty-three ateliers operating under the Lanvin name employed up to eight hundred people. That year, branches of Lanvin were opened in Cannes and Le Touquet. Through the years the house continued to grow, with several other boutiques opening in foreign locales: In 1927 alone, additional shops were opened in Deauville, Biarritz, Barcelona, and Buenos Aires. Lanvin created departments for menswear, furs, and lingerie in 1926 and then launched several successful fragrance lines, including Arpège (1927), Scandal (1933), and Rumeur (1934).

When Jeanne Lavin died in 1946, her daughter, Marie-Blanche, became the chairman and managing director of Lanvin and Lanvin parfums; she remained at the helm of the businesses until her death in 1958.

In 1950 Marie-Blanche invited Antonio Canovas del Castillo to design the haute-couture collection. This position passed to Jules-François Crahay in 1963; to Maryll Lanvin, the wife of Jeanne Lanvin's nephew, in 1985; and, finally, to Claude Montana in 1990. He presented five haute-couture collections, two of which won the Golden Thimble Award from the Chambre Syndicale de la haute couture parisienne. By 1993 the House of Lanvin had withdrawn from haute couture to concentrate on their image as a luxury goods house.

The design career of Madame Lanvin survived sixty-one successful and productive years. Lanvin is the oldest surviving couture house in continuous existence, from 1909 to 1993. In the early 2000s, Lanvin continues to focus on ladies' ready-to-wear clothes and luxury accessories. Collections for men and made-to-measure sportswear are also produced. Fragrance remains part of the Lanvin offerings, releasing Oxygene to the masses. L'Oréal, the parent company, sold Lanvin to an unidentified Chinese owner in 2001 who focused on finding a designer who could put a modern edge on the historic, antiquated company; among designers employed during this period were Ocimar Versal Oto and Christine Ortiz. In 2003, Alber Elbaz began designing the luxury collection and has been making considerable progress in reviving the Lanvin name, gaining a more youthful clientele of models and celebrities.

#### Social Life

For the sole purpose of advertisement and publicity, Madame Lanvin employed the innovative technique of dressing the highly social demimondaines and actresses. Informally modeling the latest creations of the couture house, they created great interest among the social set. Demimondaines were a less respectable group of women who had lost their social standing—although they were highly social and extremely fashionable—due to sexual promiscuity or other ethically questionable activities (such as prostitution). Their male companions gave them the money to buy the finest fashions and accessories; in fact, demimondaines were notably the most fashionable women in town.



**Jeanne Lanvin et sa fille, 1907.** This photograph was the inspiration for the Lanvin insignia. PATRIMOINE LANVIN, DROITS RÉSERVÉS. REPRODUCED BY PERMISSION.





"The longevity of this couture house may be attributed to the untiring force and determination of a woman driven by the relentless need to create, succeed, and excel within her chosen field among many worthy, predominantly male, contemporaries."

*Dean L. Mercerom*

Unlike her successful contemporaries, Madame Lanvin shunned the spotlight. She avoided large social settings, preferring her small, creative circle of artists, musicians, designers, and writers. On rare occasions Madame Lanvin could be seen at horse races for the sole purpose of research. Her attendance at these events enabled her to see what women were wearing, what looked good and what did not, how fabrics moved, how silhouettes looked, what was cumbersome, and what was ridiculous. In addition, by observing what the women were wearing, she could deduce what they would next be desiring to add to their wardrobes. Lanvin downplayed her image and personality, maintained a discreet background position, and rarely socialized with her clients. These habits contributed to her anonymity in the years following her death.

### Inspiration

The originality of Lanvin garments, constructed in such a masterly fashion, lay in their surface detail and embellishment. Madame Lanvin extracted inspiration from various objects to be translated into viable, modern, functional design. For example, her signature color, "Lanvin blue," was inspired by the fifteenth-century Italian frescoes of Fra Angelico. Her desire to create the perfect colors for her designs prompted her to establish her own dye factories in Nanterre in 1923. This shrewd move ensured the originality and exclusivity of her colors, and, indeed, competitors who tried could never successfully duplicate them.

The beading and embroidery patterns on her designs were inspired by various exotic elements and destinations. Lanvin was an avid traveler and methodical collector of objects from various cultures around the globe; they later served as a personal library of inspiration.

### Versatility

The House of Lanvin was a fashion leader and innovator in the 1920s, utilizing extraordinary beading techniques; and in the 1930s, with technically innovative surface treatment ensuring the singularity of her creations. Versatility contributed to the longevity of the couture house, as the Lanvin image was clearly defined and

redefined from season to season. Marie-Blanche was her mother's muse and lent her youthful perspective to the designer's creative ideas. Consequently, the House of Lanvin forever maintained its image of youth, femininity, and beauty.

### Cientele

Lanvin women typically began their association with the house as debutantes and maintained their loyalty through their weddings, motherhood, and widowhood. The youthful silhouette of the *robe de style*, synonymous with Lanvin, experienced great success, as it was offered in every collection. It flattered every figure at every age for all occasions. The *robe de style* was inspired by eighteenth-century fashions and consisted of a quasi two-dimensional silhouette created by the use of a pannier, or basket-like structure on either hip. This silhouette achieved great success during the 1920s as an option to the slender, cylindrical silhouettes promoted by other couturiers.

Madame Lanvin successfully combined romanticism and historicism in the most modern way. "Modern clothes need a certain romantic feel," she remarked (*Vogue*, 1 June 1942, p. 66). The youthful, elongated torso and romantic full skirts created a large surface that served as a canvas for any tasteful combination of beading, embroidery, or appliqué.

While the success of the vast Lanvin empire was a substantial accomplishment in itself, Madame Lanvin applied her skills to other creative areas as well. Pooling her talents with Armand Albert Rateau, a great French architect, in 1922, she completed several interior design projects, including her own homes, shops, and the Théâtre Daunou. She also opened her first interior decoration store, Lanvin Décoration. In addition, she shouldered the enormous responsibility of organizing and executing the couture exhibits at many of the great world expositions. For these efforts she was created chevalier of the Légion d'honneur on 9 January 1926. In 1938 Madame Lanvin was made an Officier of the Légion d'honneur.

Lanvin's legacy to the world of fashion is youth, beauty, and femininity—modernity softened with romance; beautiful colors in feminine silhouettes that blur the lines of age. The *robe de style* was a dress that could be worn literally by everyone. Lanvin was primarily an artist, and a businessperson second. She was guided by her artistic sensibility and supported by her fair sense of business and strong work ethic. She was an innovator and a leader, working for the industry as a whole, not just for the house of Lanvin. As one who "had it all," she was a role model for women: She started her own business, married, and had a child. Even as a single mother, she continued to run her empire and raised her daughter to be an inspirational success.

See also **Color in Dress; Dyeing; Twentieth-Century Fashion.**

## BIBLIOGRAPHY

- Barillé, Élisabeth. *Lanvin*. London: Thames and Hudson, Inc., 1997.
- Picon, Jérôme. *Jeanne Lanvin*. Paris: Flammarion, 2002.
- Vial, Franck Olivier, and François Rateau. *Armand Albert Rateau: Un baroque chez les modernes*. Paris: Éditions de L'Amateur, 1992.

Dean L. Merceron

**LATIN AMERICAN FASHION** Latin American dress and fashion refers to the dress, body, and culture of a large and heterogeneous world culture region that includes Mexico, Central America, the Caribbean, and South America. Given that the nature of dress in Latin America is highly diversified, one can look to overlapping socio-historical influences that have shaped the pursuit of elegance and transformed the dynamics of everyday life to elucidate some general characteristics.

When Christopher Columbus claimed the islands of Cuba as well as the Dominican Republic and Haiti for Spain in 1492, he initiated the conquest of the indigenous populations living in the region that came to be known as Latin America and the Caribbean. The first images and accounts of American natives that circulated throughout Europe reveal much about a sense of awe experienced by the first colonizers. They view the natives' nakedness with bewilderment and marvel at the presence of material goods such as cotton cloth, intricate feather work, and weavings. This "New World" would provide Europe with material goods as varied as silver, gold, sugar, chocolate, textiles, and dye. Portugal, involved in its own push for colonial power, would successfully challenge Spain for the region that makes up the country of Brazil. As Spain and Portugal quickly established colonial governments, the native populations suffered the effects of brutal conquest, incurable disease, and forced conversion to Christianity. Friar Bartolomé de Las Casas harshly condemned the exploitative practices of conquistadors and settlers who had turned to slavery and other forms of systematic violence to establish ranches, mines, and textile industries.

To maintain a sense of hierarchy and respond to increasing *mestizaje*, or racial mixing, a caste system was established throughout the region. Prior to colonization, dress and textiles had often served as indicators of social and religious identity and as a medium of exchange. The caste system forced natives and African slaves to wear Western styles of dress, thereby reinforcing the authority of the Spanish and Portuguese, and over time, their Creole descendants. Some indigenous communities gave voice to their history and religious beliefs with the help of intricate color-coding systems, as found in woven textiles or compilations of strings. In this way, the *huipil* of Guatemala and the highlands of Mexico placed deities of

the sun and the underworld in dialogue with the Christian faith. Still worn today, this traditional blouse component of the Mayan *traje*, or dress, reveals information about a woman's village, status, heritage, and personal beliefs. Recent excavations in Argentina and Brazil point to the African as well as Islamic origins of some pieces of jewelry found near the sites of plantations and urban mansions, suggesting that accessories may not have been censored by colonial authorities in the same way as dress. As court records indicate, one could wear almost any design provided that it was gender specific. The selection of fabric, however, was a highly serious matter. Depending on her social status, a Mexican woman of the eighteenth century would have purchased either a silk or cotton *rebozo*, or scarf. Decrees prohibited the use of certain textiles by those who the caste system deemed as inferiors, thus leading to the prohibition of velvet or taffeta for specially fashioned Incan *unkus*, or tunics, in the Andean region.

By the early nineteenth century, the region experienced several calls for independence from Spain and Portugal that deeply affected the way people consumed fashion. For Cuba and Puerto Rico, this struggle for independence would not materialize until the end of the nineteenth century, although the description of fashion and dance in several literary works began to plot the demise of Spanish rule and to construct alternate political identities. In the visual imaginary of this period, Creole leaders such as Simón Bolívar (Venezuela) and José de San Martín (Argentina) appear in wind-swept capes and uniforms of their own design. Many women found themselves called upon to sew the accessories of war, their products in view and their identities concealed. A few, among them Juana Azurduy de Padilla (Bolivia) and Josefa Tenorio (Argentina), took on male uniforms in order to fight on the battlefield, later arguing that they merited equal status in postcolonial society. Distancing themselves from the customs of Spain, fashionable women of Buenos Aires transformed the Spanish *peineta*, or hair comb, into the three-foot-by-three-foot Argentine *peinetón* in order to assert their presence and at times obstruct the very public sphere that professed independence from oppression but which, ironically, had not yet granted all the privilege of citizenship. In satirical caricatures from the period, the enlarged crests of women's combs take to downtown Buenos Aires and quickly overpower the top hats of men.

Following the retreat of Spanish colonialism, the rhetoric of fashion provided a forum for discussions on the configuration of national identity. In some cases, fashion writing allowed intellectuals to disseminate important political agendas and evade censors. In the Southern Cone region, the regime of Juan Manuel de Rosas sought to eliminate the political opposition by requiring a scarlet insignia on a *chaleco*, or men's vest, of all citizens. In a violent push toward homogeneity, a decree prohibited light blue, the identifying color of the opposition, and green,

a well-known symbol of hope. In this challenging climate, socialites introduced a secret language of fans, coded inserts for top hats, and message-revealing gloves, to state what was on a wearer's mind. Appropriating metaphors from the realm of fashion, in 1837, a group of Argentine intellectuals founded a fashion magazine, entitled *La Moda* after the audacious *La Mode* that had served as a force of violent opposition in revolutionary France. Using female pseudonyms and taking advantage of the fact that few associated fashion writing with politics, these founding fathers of modern Argentina asserted their urban, democratic ideals before seeking exile in neighboring Chile and Uruguay to avoid persecution. In an exploration of the dynamics of civilization and barbarism in his native country, Domingo Faustino Sarmiento, one of *La Moda's* founders and a future Argentinean president (1868–1874), advocated a consolidation process that shed the nation of its traditional rural values, epitomized by the lawless poncho-clad gaucho who had long upheld Rosas's power; Sarmiento's goal was for the country to embrace an urban, and therefore more "civilized," lifestyle more conducive to the government's goals for economic growth and modernization. Economic booms at the end of the nineteenth century would earn Argentina the reputation of the Paris of South America, as its cityscape stood transformed into an allusion of luxury, consumerism, and international capitalism.

With the massive influx of European immigrants to Latin American cities at the turn of the century, luxury took on a fraudulent role. Members of the nouveaux riches and new arrivals began to imitate the styles of the upper classes in order to find work, holding in high esteem the novelties of Paris. With the emergence of the fashion lithograph, *modistas*, or tailors, copied European designs (sometimes appropriating styles for the climate of a particular region) and then commissioned seamstresses who, enduring miserable working conditions, pieced garments together with the help of sewing machines. While women's dress had become a bit more flexible, it still incorporated the corset and layered skirts and trains that required bustles. As sewing machines became more affordable, many women opted to purchase ready-made clothing or to fashion their own, more comfortable, styles at home. Encouraging readers to consider individualized designs and the prospect of female emancipation, Juana Manuela Gorriti (Argentina) and Clorinda Matto de Turner (Peru) used the language of fantasy and self-transformation, or fashion writing, to enter a public debate on materialism and female economic autonomy.

During the twentieth century, Latin American dress would inspire several fashions in Europe and the United States, from the blouse with lace ruffles inspired by the Afro-Cuban rumba, to the well-known Mexican *huaraches*, or woven leather sandals, to the straw Panama hat actually created in Ecuador. *Vogue* and *Look* turned attention to trendsetting Latin American women whose visions of

haute couture, as in the case of Eva Perón (Argentina), and native designs, bringing to mind the surrealist painter Frida Kahlo (Mexico) who incorporated folkloric *china poblana* costume in bright colors and with a full skirt in her self-portraits and in real life, would continue to resonate in the popular imaginary until the present day. Other, more contemporary, fashion statements have tended to revisit the past for a retro effect, such as the young Cuban American donning the *guayabera*, a lightweight, embroidered cotton shirt worn untucked throughout the Caribbean; or the Chicano zoot-suiter, whose wartime appropriations of his father's suits inspired ethnic pride in the face of racism and brutality; or the teenage club kid wearing Inca-techno styles while discotheque dancing.

The latter part of the twentieth century witnessed a horrifying backlash against democratic values when countries such as Argentina, Chile, and Uruguay installed military governments. Strict gender codes imposed clean-cut looks for men and feminine styles for women. Responding to human-rights abuses and the plight of the "disappeared" (which refers to the tens of thousands of victims who were killed or whose whereabouts still remain unknown), the Mothers of the Plaza de Mayo in Argentina began to protest near important national monuments in their morning robes and house slippers, as if to state visually that they had no one at home to care for, as the regime had taken away their sons and daughters. The Mothers wear a white scarf, embroidered with the names of their missing loved ones, during their weekly marches. Serving as living monuments for the victims of repression, mother's groups in El Salvador and throughout the world have appropriated this same white scarf in their struggles against social injustice.

The revolutionary movements of Cuba (1959–) and Nicaragua (1979–1990) signaled a turn toward socialist antifashion, which associated the elitist pursuit of luxury with the kind of capitalist domination that created dependencies on foreign goods and exploited the working classes. Indeed, much of Latin America had experienced uneven economic development throughout the twentieth century. In the garment industry, multinationals relied on the cheap labor of native workers for the weaving, assembly, and sewing of garments. But in more recent years, even revolutionary Fidel Castro (Cuba) occasionally shed his camouflage for the sartorial pleasures of a dark-blue designer suit. A heightened awareness of the sweatshop conditions of the *maquiladora*, the export-processing zones established in 1960s that continue to operate under the North American Free Trade Agreement (NAFTA), sometimes led consumers to boycott specific collections and push for a more socially conscious fashion system. Some designers, such as Carlos Miele (Brazil), have worked with women of the *favelas*, or shantytowns, and various indigenous communities to establish cooperatives that will ensure fair-trade wages for their creations.



Responding to the possibilities offered by a global marketplace and Internet connections, Hispanic designers Carolina Herrera (Venezuela), Oscar de la Renta (Dominican Republic), together with Beth Sobol (United States) and Victoria Puig de Lange (Ecuador), formed the Council of Latin American Fashion Designers in 1999. An affiliated Fashion Week of the Americas established an international platform for Latin American fashion and culture. In newspapers, a new word surfaced in popular culture that combined *fashion* and the Spanish suffix *-ista* (implying, with a tinge of sarcasm, a devotee). The dress-conscious *fashionista* scoured the ever-expanding style pages of newspapers and e-zines for information about new talents like Narciso Rodríguez (United States), the famed designer of Carolyn Bessette Kennedy's bridal gown, and faced the proliferation of fashionable identities with gusto. In the urban centers of São Paulo, Buenos Aires, and Bogotá, supermodels such as Gisele Bündchen (Brazil) and Valeria Mazza (Argentina) promoted national fashion events with international appeal. At the same time, free-trade agreements between countries, such as the Mercosur block of the Southern cone region, have enabled fashion designers to create transnational organizations, such as *Identidades Latinas*, to tap into new markets. Among others, the houses of Laurencio Adot (Argentina), Alexandre Herchcovitch (Brazil), Ronaldo Fraga (Brazil), Rubén Campos (Chile), Silvia Tcherassi (Colombia), Sitka Semsch (Peru), and Angel Sánchez (Venezuela) earned strong reputations in the category of women's wear. Lina Cantillo and Ricardo Pava (both of Colombia) seemed best known for their men's collections. Fraga and Sylma Cabrera (Puerto Rico) were noted in fashion circles for their attention to children's wear. Into the twenty-first century, the reputation of Latin American fashion designers continued to rise on the world fashion stage.

See also **Latino Style**.

#### BIBLIOGRAPHY

- Bauer, Arnold J. *Goods, Power, History: Latin America's Material Culture*. Cambridge and New York: Cambridge University Press, 2001.
- Holland, Norman. "Fashioning Cuba." In *Nationalisms and Sexualities*. Edited by Andrew Parker, Mary Russo, Doris Sommer, and Patricia Yeager. New York: Routledge, 1992.
- Masiello, Francine. *Between Civilization and Barbarism: Women, Nation, and Literary Culture in Modern Argentina*. Lincoln and London: University of Nebraska Press, 1992.
- Meléndez, Mariselle. "La vestimenta como retórica del poder y símbolo de producción cultural en la América colonial: De Colón a El lazarillo de ciegos caminantes." *Revista de Estudios Hispánicos* 29 (1995): 411–439.
- Root, Regina A. "Tailoring the Nation: Fashion Writing in Nineteenth-Century Argentina." In *Fashioning the Body Politic*. Edited by Wendy Parkins. Oxford: Berg, 2002.
- , ed. *Latin American Fashion*. Oxford: Berg, 2004.

Regina A. Root

**LATINO STYLE** Latinos are people of Latin American ancestry in the United States. "Latino" is a term that embraces cultural differences among Spanish-speaking people and persons with indigenous and/or African American roots with ancestry from Latin America and the Caribbean. Thus, Latino or Latina style is a collective phrase that expresses group style for a diaspora of people.

In its broadest sense, Latino style is a contemporary manner of dressing by Latinos who pay particular attention to personal, fashion, or ethnic style that sets them apart from other ethnic groups in the United States. It is difficult to specifically characterize Latino style because Latinos as a group are not homogenous. However, Latinos tend to have high fashion interest, be brand conscious and loyal, and devote a larger percentage of household income to clothing purchases than other ethnic groups.

#### Latino Celebrities and Magazines

A rising Latino population and an increasing number of Latino celebrities are kindling interest in Latino cultures. Selena, the Tejana songstress, is credited with sparking widespread attention to the Latino market in the 1990s. In the early 2000s, actress and singer Jennifer Lopez (J.Lo) has influenced fashion with her clothing line and personal style. Contemporary Latina celebrities reflect strong personal styles and high fashion orientation, but minimize ethnic style compared with stereotyped Latina actresses of the past, such as Carmen Miranda.

Latino celebrities, including Jimmy Smits, Antonio Banderas, Ricky Martin, and Oscar de la Hoya, exude handsome masculinity. Latino actors are often portrayed as the "Latin lover" stereotype or a power figure. Latinos reflect less risk-taking in their appearance than Latinas, but certainly a strong sense of personal style and high fashion interest are evident.

Latina style is often illustrated as sexy, fashionable, and urban in contemporary magazines such as *Latina* and *Urban Latino*, by featuring longhaired models wearing body-revealing fashion clothing and emphasizing makeup wear. Other magazines, such as *Latina Style*, portray Latinas as educated professionals who are family-oriented and style-conscious. There is clearly an attention to appearance by the businesswomen featured in *Latina Style* that encompasses polished hair, makeup, and clothing styles.

#### Fashion

Latino style and mainstream fashion have also been shaped by noncelebrities, such as working-class Latinos. For example, in the 1980s, *cholas*, female gang members, began wearing a distinct dark lip liner and lighter lipstick that became a popular mainstream fashion.

A new phenomenon is the growth of Internet sites and product lines devoted to Latino style. Patria, a fashion house in New York City, offers fusion fashion inspired by the Latino experience. The Havanera Co. is a "Latin inspired brand" by Perry Ellis International.



### CHICA, INC.

Founded by Helen Martinez, a Latina and a University of Southern California graduate, Chica, Inc. clothing company ([www.chica1.com](http://www.chica1.com)), targets Latinas from ages twelve to forty. Chica consumers are characterized as having ethnic pride, being self-assured, and connecting with the Spanish language. The company advertises its T-shirts as “having attitude.” Presently, Chica clothing is sold in high-volume department stores, such as Macy’s and Mervyn’s.

Zalia Cosmetics promotes makeup for Latinas, and Web sites sell Latino-inspired merchandise. Increasingly, Latino youth act as fashion trendsetters, sporting branded clothing, and fueling fashion. In fact, this bi-cultural Latino population is becoming known as the “J.Lo generation.” Moreover, institutions are highlighting Latino fashion contributions to the larger United States society.

#### The Quinceañera

Particular manifestations of Latino dress include special-occasion dress, costume for performance, unique day wear, and group dress. A *quinceañera* is a celebration for young girls of fifteen as an initiation into adulthood. With origins in pre-Columbian cultures, *quinceañeras* have spread to many Latino cultures and religions. The celebration often includes a mass followed by a reception. The *quinceañera* wears an elaborate floor-length ball gown of white, cream, or a pastel color. The ensemble can include a train, headpiece, gloves, high-heeled shoes, and elaborate hair and makeup. The celebrant is accompanied by a similarly dressed female court and male attendants wearing tuxedos.

#### Mariachi

Another familiar dress is that of mariachi, the “uniform” of musicians who perform a specific type of Mexican folk music. The contemporary ensemble was borrowed from the elegant suits worn by *charros* (Mexican horsemen) and gentlemen ranchers that include a close-fitting short jacket, close-fitting pants, shirt, belt with large, ornate belt buckle, wide bow-tie, boots, and sombrero. The sombrero, jacket, and pants are elegantly embroidered and may include extensive silver ornamentation.

#### Guayabera

A guayabera is a men’s shirt style that signals Latin American heritage and is worn by men of all ages. Originating in Cuba, the guayabera is the quintessential shirt worn

in hot climates. Made of lightweight fabrics, it is usually white, cream, or pastel colored, and is worn untucked. The guayabera is distinguished by its vertical rows of pin tucks or embroideries on the front and back, four symmetrical pockets, straight hem, and side vents.

#### Pachuco Style

In the twentieth century, group style emerged among Latino youth. The “pachucos” of the 1940s surfaced in the barrios of Los Angeles and the southwest. Pachucos were recognized by their distinct dress, mannerisms, and language. Dress for males was the adopted zoot suit, consisting of baggy, pleated pants with pegged legs and cuffs, elongated, padded shoulder jackets, long watch chains, hats, and thick-soled shoes. Hair was worn long and slicked back in a ducktail style. Females, “pachucas,” wore tight, short skirts, sheer blouses, long hair, and heavy makeup. The Zoot Suit Riots of 1943 took place in Los Angeles and were the result of bias against Latinos; there was not any real provocation.

Pachucos are thought to be the precursors of low riders and of the *cholos* who emerged in the latter half of the twentieth century with their own distinct dress styles. Low riders are largely Chicano car-club members whose vehicles have been heavily customized and ride low to the ground. Multiple generations of low riding may exist within a family. Low-rider culture, cars, and persons are featured in *Lowrider* magazine, which first appeared in 1977.

#### Cholo Style

*Cholos* are urban youth who may be gang members, car-club members, or simply influenced by the *cholo* lifestyle. Gang members are called gangsters. They are identified by their unique style of dress, speech, and gestures. Although *cholo* style varies from group to group, khaki pants, white T-shirts, plaid long-sleeve shirts, and bandanas are included. *Cholas* are usually gang members who wear khaki pants, T-shirts or tank tops, plaid long-sleeve shirts, flat black shoes, extensive makeup, and long hair. Makeup includes heavy eyeliner and brown lipstick. Both *cholos* and *cholas* may signal gang membership through tattoos and the use of unique hand gestures specific to a group.

See also **Latin American Fashion; Zoot Suit.**

#### BIBLIOGRAPHY

- Castro, Rafaela G. *Chicano Folklore: A Guide to the Folktales, Traditions, Rituals and Religious Practices of Mexican Americans*. Oxford: Oxford University Press, 2001. An excellent resource for understanding Latino terms, with an extensive bibliography.
- Harris, Mary G., ed. *Cholas: Latino Girls and Gangs*. New York: AMS Press, 1987. Illustrates the importance of appearance within gangs.
- Plascencia, Luis F. B. “Low Riding in the Southwest: Cultural Symbols in the Mexican Community.” In *History, Culture and Society: Chicano Studies in the 1980s*. Edited by Mario T.

Garcia et al. Ypsilanti, Mich.: Bilingual Press, 1983. Scholarly understanding of the appropriation of symbols and terms to promote low-rider activities. Excellent references.

Rodríguez, Clara E., ed. *Latin Looks: Images of Latinas and Latinos in the U.S. Media*. Boulder, Colo.: Westview Press, 1997. Good overview of issues about Latinos celebrities.

Salcedo, Michele. *Quinceañera!: The Essential Guide to Planning the Perfect Sweet Fifteen Celebration*. New York: Henry Holt, 1997. Provides planning guide and traditions of quinceañeras.

Sands, Kathleen Mullen. *Cbarrería Mexicana: An Equestrian Folk Tradition*. Tuscon: University of Arizona Press, 1993. Excellent book that includes the foundations of mariachi dress.

Solomon, Michael R., and Nancy J. Rabolt. *Consumer Behavior in Fashion*. Upper Saddle River, N.J.: Prentice Hall, 2004. Brief but valuable segment devoted to Hispanic consumers.

#### Internet Resource

Cihlar, Kimberly. "The Good Life: Totally Shirttious." *Cigar Aficionado Magazine*, May/June 1999. Available from <[http://www.cigaraficionado.com/Cigar/CA\\_Features/CA\\_Feature\\_Basic\\_Template/0,2344,618,00.html](http://www.cigaraficionado.com/Cigar/CA_Features/CA_Feature_Basic_Template/0,2344,618,00.html)>. Good resource for history of the guayabera.

Josephine Moreno

**LAUNDRY** The French word *laver*, meaning "to wash," derives from Latin. It came into English usage (*lavendry*) in the twelfth century. By the sixteenth century, "laundry" and its associated terms were commonly used to describe dirty clothes in need of washing, the place they would be washed, and the individual whose task it was to wash them.

The history of laundry, however, is much older. Ancient civilizations were familiar with many "modern" laundry practices. Archaeological evidence survives of Babylonian soap-making in 2800 B.C.E. and Egyptian laundries from around 2000 B.C.E. During the Chinese Han Dynasty (206 B.C.E.–220 C.E.) delicate silk was washed with a natural soap, probably derived from the Soapberry tree (*sapindus saponaria*), which was known in China as well as on the African coast at that time.

In Europe, from the classical Greek era through the time of the Roman Empire and into the Dark Ages, laundries were used by the prosperous to clean clothes, and soap-making had become a craft by the seventh century. Urine, dung, and lye formed the basis of common cleaning substances, and a variety of domestic methods, utilizing streams, tubs, or troughs, were used to clean clothes and other household items. Laundresses are regularly mentioned in records from the Middle Ages, as washing was seen as women's work, but the majority of households would have used neither soap nor laundresses. Cleanliness was still an attribute of wealth.

Lye, made by passing water through ash (potash), appears to have been the most common washing substance

**SILKS—SATINS—LACE**  
Kept dainty and new through the longest vacationing

MADAME has given instructions to pack only the finest, the flimsiest. The silk and Valenciennes underthings and the shimmest of the stockings. The gorgeous frocks with their extravagantly simple size. Two favorites negligees and the loveliest of the blouses.

Always Madame refuses to be bothered with the great number of fat pouffes—only the most slender. For with Lux these few can be kept in fresh, no expense.

At the first speck of dinginess in flat collar or cuff, Marie traces the lintless one into a big handful of Lux soap. The foamy bubbles cover it. The rich lather passes through and through it. Every tiny thread is washed out and cleaned away when.

In half an hour the pretty thing will be bright and sweet and summery again, looking so daintily new as if it had just come out of the specialty shop's tissue wrapping!

The old way of washing was as heartless. Many a fragile blouse had Madame weep over in the old days—actually scrubbed to death! But the Lux way is so different. It is so gentle, so careful with her flat things.

There's never a bit of nasty cube soap to stick to the silk thread and be teased into it! Never a thought of a cruel suds! The pure suds just whisks the dirt away and leave the fabric white and new, the color clear. The grocer, druggist or department store has Lux always ready for Madame. Laver Bros. Co., Cambridge, Mass.

How to launder silks  
Which a tablespoonful of Lux soap which lather in half a bucket of very hot water. Add cold water and detergent. Dip the garment up and down in the rich lather. Squeeze the suds through it and use cold water in three successive washes. Roll in a towel. Then squeeze dry and press with a warm iron. Finally, the garment's crease should be gently pulled over flat on one dry, and should also be shaped as you wear.

If you see wet stain or color in fabric  
If possible, first wash it simply and dry it. If the stain runs are in silk, or delicate fabric, use hot and cold water to remove it. Use hot water to remove it. For blue use half a cup of vinegar. For laundry, use one tablespoonful of sugar of lead. Wash for half an hour and then iron thoroughly before washing. Colors must be set before each washing.

**LUX**  
For all fine laundering

Copyright 1925, by Laver Bros. Co.

**Advertisement for laundry soap.** In the early 1900s, several delicate new fabrics such as rayon, nylon, and acetate were introduced, creating a need for less harsh laundry detergents. © BETTMANN/CORBIS. REPRODUCED BY PERMISSION.

for clothing made of materials such as flax, hemp, cotton, and wool. The alkali in lye helped release the dirt and clean water helped restore the clothes that were later laid out in sunlight to dry and bleach. Many different types of lye mix, some made with ferns, could be found across Europe. Soap, made by heating a mixture of fat and oil with lye and salt, was known in the ancient world but later was largely forgotten. Soap reappeared in Europe again from the seventeenth century onward, but for many years to come it was regarded as a luxury item; in England there was a luxury tax on soap from 1712 to 1853. Soap thus did not begin to supplant lye as the primary cleaning substance for laundering until the late eighteenth century.

By the seventeenth and eighteenth centuries, many households had rudimentary washing equipment. Stronger materials such as wool or linen were pounded against rocks or wooden blocks with smooth or ridged implements called "bats," "beetles," or "battledores." Lye, the washing substance, was produced from a lye dropper—a wooden box with holes in the bottom fitted over the washtub. Washing "dollies"—poles with ends shaped like a cone—were used to plunge washing around in tubs of boiling water and became popular in the nineteenth century.



● *These women tried some of those no-rinse chemicals. Here's what they say—*

**FOR WHITE  
WHITE  
WASHES**



"I wash 20 shirts a week!" says Mrs. L. H. Willey of Bangor, Maine. "I tried several of those no-rinse chemicals and went right back to Duz. Duz gives me snowy white washes without making my hands rough and red."



"Common-sense tells you," says Mrs. B. W. LeFave of Spokane, Wash., "that a soap so kind to hands must be safe for colored things in my machine! I've gone back to Duz—for clean, white, safe washes every time!"



**WITHOUT  
RED  
HANDS**



"My hands are in water so much," says Mrs. E. E. Watson of Kansas City, Kans., "I've got to give them a break! I tried some of those no-rinse chemical suds—but went back to Duz in a hurry!"

**"I'VE GONE BACK  
TO DUZ!"**

**ONLY DUZ**—of all leading washday products—gives you this great combination of rich, real soap and two scientifically-tested detergents for dazzling clean, white washes!

**ONLY DUZ**—of all leading washday package soaps or "suds"—is so kind to your hands, so safe for colors! Yet no soap known gives you a cleaner, sweeter-smelling wash!

**DUZ DOES EVERYTHING**

*Works Wonders Even in Hardest Water!*

OCTOBER, 1950

Advertisement for Duz laundry detergent. Early twentieth century advertising for laundry soaps emphasized the importance of cleanliness in middle-class society and advocated doing laundry as appropriate feminine behavior. © BETTMANN/CORBIS. REPRODUCED BY PERMISSION.

However, until the eighteenth century, laundry methods and equipment remained largely unchanged. In the eighteenth century, early washing-machine design was underway as well as laundry recipes and equipment, including handmade mangles and scrubbing boards. Washboards were becoming more popular and were used with wider bath-shaped tubs. These devices were quicker and easier to use than the dollies. Eighteenth-century chemical discoveries and nineteenth-century advances in mechanization spurred the development of improved laundry processes and services.

During the early part of the nineteenth century, laundry work remained a small-scale, technologically unsophisticated trade, often performed by women in their own home or their employer's home. Toward the end of the nineteenth century, cities and services expanded, and women's employment outside the home increased, as did the size of the "middle classes" with substantial laundry needs. The diffusion of fashionable clothing to a larger segment of the population in the nineteenth century expanded the demand for laundry services. The growth of office employment—classic "white collar" work—led to increased demand for laundry services, as clean clothes were seen as a sign of status for such workers. Other workers (such as women in domestic service) also were increasingly expected to wear clean uniforms and aprons so that by the late nineteenth century, washing expenses incurred by laboring families were sometimes equal to half the sum they spent on rent.

These social developments, and the emergence of effective machinery, improved bleaching agents, and color-fast synthetic dyes led to the increased industrialization of laundry services. By the middle of the century, laundry had become a large-scale modern industry. In Great Britain public laundries came into being in the mid-nineteenth century; in the 1890s there was a sharp increase in power laundries. By the 1890s mechanized steam, gas, and electricity helped to fuel the service-sector growth of laundries. From 1890s to World War I, there was a move toward large steam laundries in Britain and America.

Economic relations, of course, determined not only what, but *who* washed the clothes. Laundry work historically had been primarily the work of poor women, and this remained true with the industrialization of laundry work in the nineteenth century. In the United States from around 1850, Chinese men also became associated with laundry, and by the 1880s, for example, 10 percent of the men in San Francisco's Chinese community worked in the laundry trades. By 1900, when piped water became more commonplace in many parts of the United States, most large American towns had a Chinese laundry, which offered both cleaning and pressing services. Both European-style steam laundries and Chinese hand laundries in the United States were associated with poor employment conditions, and pioneering social reformers pro-

duced studies that revealed long hours and arduous labor demands in the industry.

By the nineteenth century, chlorine, detergent, water starches, and blue bleaches were in use. Around 1850–1880 hard bars of soap (brands such as *Sunlight*) became more popular. Soap was still expensive, and it was not yet differentiated into "laundry soap" and "hand soap;" one bar would be used for all cleaning purposes. Soap flakes, pioneered in 1830, became ubiquitous from the turn of the century, culminating in the introduction of Persil (1906/07) in England. Persil offered a combination of washing and bleaching agents in one powder, and was followed by Hudson's new range including Omo (1908) and Rinso (1910).

The idea that new types of gentle but effective cleaning products were needed, coincided with the emergence of new fabrics, such as rayon (1910), acetate (1927), and more significantly, nylon (1939). New materials transformed the lingerie and fashion industries, but could be neither dry-cleaned nor roughly pounded during washing. The development of easy-to-wash, stable, "drip dry" contemporary fabrics, such as polyester and nylon and so many derivatives (bri-nylon, nylon chiffon, leather-look simplex, fake fur, and more), saw the reduction of demand for public laundries, along with the expansion of the dry-cleaning industry. Dry cleaning was inadvertently invented in 1849 when Parisian tailor Jolly Bellin accidentally spilled turpentine and learned to remove stains from a table cloth. By 1866, dry cleaning was a growing business. Pullars of Perth was offering a postal dry cleaning service anywhere in the British Isles and had developed advanced cleaning methods using petroleum and benzene, as well as specialist skills to deal with unstable fabrics. Dry cleaning, as compared with laundry work, demanded new kinds of expertise about volatile materials—not just dyes, but also finishes, interfacing, linings, buttons, trims, and threads now being used in contemporary fashion.

From 1914 onward, advertisements in newspapers, magazines, and journals linked cleaning products to female users, modernity, and social improvement. More women again were doing the washing at home. Cleanliness was a sign of gentility and respectability. Middle-class anxieties about dirt brought a new focus on "hygiene" at home and in the colonies; the phrase "the great unwashed" equated dirt with lower-class status or foreignness. Unilever's advertising slogan linked cleanliness to more than godliness, declaring that "soap is civilization."

The first electric washing machine was introduced in 1906. After World War II, radio and television promotions for soap and detergent, pioneered in America by Procter & Gamble, coincided with the expanded use of washing machines; General Electric introduced a fully automatic model for home use in 1947. The rise of self-service laundrettes or Laundromats in the 1950s also contributed to the laundry industry's decline and

refocus on the hotel and business sector of the market. A century after it had become industrialized in the public realm, laundry moved back to the privacy of the home, where automatic washing machines became the standard way of dealing with the family wash and fueled the market for effective but clothing-friendly detergents. While the chemical dry-cleaning industry continued to prosper, industrial laundries in Britain and America continued to serve commercial clients, but no longer the family.

Postwar detergent and appliance advertising that also covertly promoted doing the laundry as appropriate and stereotypical “feminine” behavior increasingly legitimated women washing clothes at home. Toward the end of the twentieth century, major detergent and soap-powder brands owned by soap conglomerates such as Procter & Gamble and Unilever, even targeted “new” men and women without families, suggesting it is easy/sexy/enjoyable to wash clothes. These advertisements, often for phosphate-based cleaning brands, mean certain washing products continue to dominate the international supermarket shelves, with little choice between brands. The irony is that many laundry-product advertisements convey doubtful social messages, and the products themselves contribute to environmental problems; the desire for clean clothing has been largely solved in the early 2000s, but not without creating other social costs.

See also **Distressing; Dry Cleaning.**

#### BIBLIOGRAPHY

- Davidson, Caroline. *A Woman's Work Is Never Done: A History of Housework in the British Isles, 1660–1950*. London: Chatto and Windus, 1982.
- Gamman, Lorraine, and Sean O'Mara. *Dirty Washing: The Hidden Language of Soap Powder Boxes*. Catalogue to Design Museum Exhibition, July–September 2001. London: The London Institute, 2001.
- Malcolmson, Patricia E. *English Laundresses: A Social History, 1850–1930*. Urbana and Chicago: University of Illinois Press, 1986.
- Mohun, Arwen P. *Steam Laundries: Gender, Technology and Work in the United States and Great Britain, 1880–1940*. Baltimore and London: Johns Hopkins University Press, 1999.

*Lorraine Gamman and Sean O'Mara*

**LAUREN, RALPH** An argument can be made that Ralph Lauren is the most successful and influential designer of his time, though he is known less for the creativity of his designs than for being an astute marketer and image maker. His fascination with style began in early childhood. He was born Ralph Lifshitz in the Bronx, New York, in 1939, the fourth and last child of Frank and Frieda Lifshitz, both Jewish refugees from Eastern Europe. He was educated in both public schools and strict yeshivas and raised with high expectations.

#### Early Interest in Fashion

Even as a boy Lauren loved to dress well and was always a sartorial step ahead of his peers. He liked to try on his dapper father's jaunty hats, and he wore his older brothers' hand-me-downs with a notable sense of style. Even if his clothes were not expensive, he distinguished them with an unusual drape or combination. He knew how to tie a Shetland sweater around his shoulders just so and rolled the cuffs of his jeans in a particular and unique way. When he fantasized about being a teacher, he imagined himself wearing a tweed jacket with suede elbow patches. Ralph and his brother Jerry often went shopping together where they discovered thrift-shop clothing. The memories of those hunting expeditions still inform Lauren's collections: it was in thrift shops that he discovered the joys of rugged military clothes, the integrity of British tweed suits, the thrilling transformation that could take place when a socially backward Jewish kid donned a cowboy shirt and a pair of jeans and imagined himself at home on the range.

#### Early Career

Once out of school he became a furnishings buyer for Allied Stores, and then (having changed his surname to Lauren) a tie salesman at Brooks Brothers. After a brief stint as a supply clerk in the U.S. Army, Lauren spent the 1960s pounding the New York pavement selling gloves, men's fragrance, and ties. More importantly, however, he was refining his personal style, designing his own custom-made suits, haunting great men's stores like Paul Stuart, and gaining inspiration from custom-made suit makers like Roland Meledandri.

Lauren grew frustrated with his conservative bosses in the tie business, since they seemed unaware of the oncoming peacock revolution in men's fashion. Secretly, he designed a line of wide ties, inspired by ones made in England by the brand Mr. Fish. He sought out a backer to finance the line and others to produce it. In 1967 he launched Polo as a division of the tie-maker Beau Brummel. Soon Bloomingdale's, then America's most cutting-edge department store, discovered Ralph Lauren. Thus began an intense and mutually advantageous relationship that still thrived in the early 2000s.

#### Polo Brand

In 1968 Lauren left Beau Brummel, taking the name Polo with him, and went into business with the suit maker Norman Hilton. Lauren began expanding, first into a full range of clothing and furnishings for men, and then, in 1971, into women's fashions. Even in those early days, he displayed characteristics that defined his career: an innate understanding of branding (he embroidered his polo player logo on the cuffs of his first women's shirts, creating one of the most singular brand identities in the history of marketing); a fearless refusal to be reined in by finances or expectations; and a recklessness (doing too much too soon with insufficient capital and staff) that soon led to the first of several financial crises. Later crises were caused by Lau-



ren's fierce—but never entirely realized—desire to be as successful in women's fashions as he was, almost immediately, in men's wear. Still, he produced iconic clothing for both sexes after those first wide ties: his famous polo and oxford shirts, khakis, perfect Shetlands, prairie skirts, Navajo blanket coats, and men's wear-inspired women's suits. Over the years, despite nagging fit and delivery problems caused by his insistence on dressing only a certain body type and an almost paralyzing uncertainty over what to include in his lines, those styles won him a grudging respect. Clothing from his collections, which appeared in two acclaimed films from the 1970s—*The Great Gatsby* and *Annie Hall*—helped promote his name.

### Print Advertising

In the late 1970s, when Lauren formed a fragrance company with Warner Communications, money began pouring in, earning him serious commercial power and financing his next and perhaps greatest innovation. In partnership with the photographer Bruce Weber, who also worked for Calvin Klein, Polo began producing extraordinary print advertisements that served as mini-movies, advertising the myriad, linked product categories Lauren produced. More significantly, they hammered home Polo's most potent product, the idea that clothes not only make the man and woman, but make them whatever they want to be, whether that is a New England patrician or a Colorado cowgirl.

### Retailing Legacy

In the late 1980s Lauren and his creative services department unveiled the extensive renovation and preservation project that is the Rhineland Mansion, long one of New York's architectural treasures, and now the backdrop to Lauren's ultimate Polo retail store. It has forever redefined fashion retailing. He had become, as a biographer called him, the personification of "the commodification of status, of the democratization of symbols of the haute monde, of the perfection of luxury merchandising and the rise of 'lifestyle' marketing, and of the globalization of branding and the simultaneous Americanization of international fashion" (Gross, 2003).

Though Lauren still did not always receive the approbation of fashion editors and his peers in the fashion design world, he went on to win every award that could be bestowed on designers, as well as worldwide fame and enormous wealth. Polo grew so large that in June 1997 it became a public corporation, listed on the New York Stock Exchange.

At age sixty-five Lauren, one of the greatest businessmen-designers in fashion history, remained driven and unsatisfied, still struggling to prove himself. His attempt to reposition Polo as a premium luxury brand was a troubled one. In 2004 Polo's stock price still languished below the highs it hit the day it was first offered to the public, and investors and financiers remained skeptical not just of Polo's position in the market, but also of

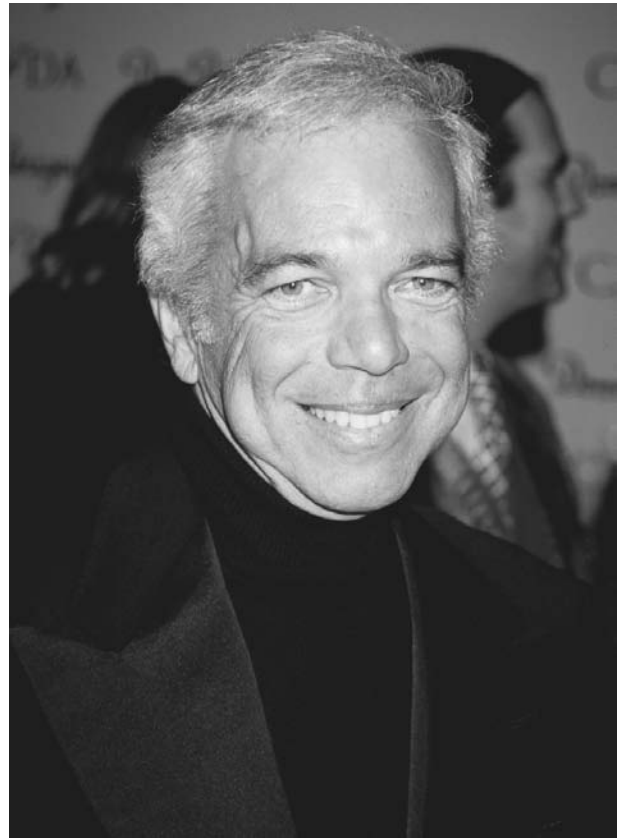

**Ralph Lauren.** Much of Lauren's success came from his canny understanding of the importance of marketing, illustrated through his creation of instantly recognizable brands. © MITCHELL GERBER/CORBIS. REPRODUCED BY PERMISSION.

its future. As head of a company heavily dependent upon his design and marketing skills, his style intuition, and his personality, Ralph Lauren showed no signs, however, of climbing off his polo pony.

See also **Fashion Advertising; Fashion Marketing and Merchandising; Perfume.**

### BIBLIOGRAPHY

- Gross, Michael. *Genuine Authentic: The Real Life of Ralph Lauren*. New York: HarperCollins, 2003.
- McDowell, Colin. *Ralph Lauren: The Man, the Vision, the Style*. New York: Rizzoli International, 2003.
- Trachtenberg, Jeffrey A. *Ralph Lauren: The Man Behind the Mystique*. Boston: Little, Brown, 1988.

*Michael Gross*

**LAVER, JAMES** Born in Liverpool, England in 1899, James Laver was a dress historian who worked at the Victoria and Albert Museum in London as a curator from 1922 to 1959. His initial interest in dress grew out of the



Laver wrote or edited seventy books between 1921 and 1972, at least twenty-seven of which had to do with dress or costume. He explored a variety of topics, from poetry to art to the theatre. He was also the author or coauthor of seven plays.

Contemporary Authors Online

need to date accurately the pictures in his care. His instrumental relationship to costume quickly changed, and, as he writes in his autobiography, “Having studied the What and the When, I began to wonder about the How and the Why” (1963, p. 240). Laver became one of the most prolific authors in the English-speaking world to write on the history of dress and fashion as well as on the sociology of those topics. Not only did he recast the conventional narratives of European high fashion, but he also wrote about nonfashionable forms of attire, such as school and military uniforms, children’s dress, and sporting clothes. He died in 1975.

### Dress and Time

Laver was fascinated by the effects that the passing of time has upon people and their works. He was greatly influenced in his theory of time by a notion of *zeitgeist*, or “time spirit,” a concept taken from nineteenth-century German philosophy. *Zeitgeist* proposes the existence of a collective psychological, or spiritual, entity that imparts a distinctive pattern of aims and emphases to a culture, nation, or historical epoch. Drawing on this idea of cultural unity, Laver concluded that every aspect of social life is permeated by the emotional and intellectual dispositions lodged within the *zeitgeist*. He broadened the scope of the original idea of the “time spirit” by aligning it to a theory of modernity, arguing that all things human are increasingly subject to dictates of “time consciousness.” Clothing is one of the things most sensitive to changes in the *zeitgeist*. In dress is found an immediate physical manifestation of the patterns of the time spirit (style), while in their rapid changes (fashion) can be observed the ever widening influence of the modern form of time. As Laver observes, “Nothing illustrates the Triumph of Time more clearly than the growing dominance of fashion” (1933, p. 132).

### Clothes and Style

Laver’s approach to the forms of clothing was based upon his belief that there are “no accidents in the history of dress” and that “all clothes are inevitable” (1949, p.6). He explains this assertion so:

In every period costume has some essential line, and . . . [when examining previous fashions] . . . we can

see quite plainly what it is, and can see . . . that the forms of dresses, apparently so haphazard, so dependent on the whim of the designer, have an extraordinary relevance to the spirit of the age (1945, p. 250).

The task is to understand the meanings of this “essential line” as it insinuates itself into the dress styles of a culture or epoch. Some of Laver’s most controversial assertions are to be found in the connections he makes between the social and political structures of an age and in the details of its dress, as indicated in *Taste and Fashion from the French Revolution until To-day*:

The aristocratic stiffness of the old regime in France is completely mirrored in the brocaded gowns of the eighteenth century. . . . Victorian modesty expressed itself in the multiplicity of petticoats; the emancipation of the post-War flapper in short hair and short skirts (1937, p. 250).

Laver wrote a book about the French physician and astrologer Nostradamus (1942) and also *A Letter to a Young Girl on the Future of Clothes* (1946). At times, he came close to seeing the interpretation of clothing and its changes as being akin to clairvoyance. He names this apparent ability of clothing to anticipate the future “the wisdom of forms.” When, later in life, he became a media personality, he would shock audiences by asserting that links exist between the fluctuations of the stock market index and a propensity for women to abandon corsets. In his book *Style in Costume* (1949), Laver describes his method for drawing these conclusions as “to take some dominant shape of dress—a hat, a trouser-leg, or whatever it may be—and to place it beside some form of architecture or interior decoration of the same epoch, and to note the parallelism, if such exists, between them” (p. 7).

### Clothes and Fashion

Laver stressed that in modern life things are increasingly subject to change, and the existence of dress fashions is evidence of the extent to which *time* has displaced *place* as the major influence on clothing. He saw the process of fashion as having two aspects. There are the broad, objective rhythms of style change in dress and the subjective, but shared, aesthetic dispositions (taste) that incline groups to prefer one type of clothing to another. Laver was convinced that neither of these sorts of change is accidental or arbitrary, and in his book *Taste and Fashion: From the French Revolution to the Present Day* (1945), he attempted to describe and explain the regularities he noticed in both these areas.

Laver’s approach to taste is novel because, rather than focusing on why certain types of clothing are deemed fashionable, he instead asks the question: How can it be that what was thought of as fashionable becomes grotesque and can then start to appear charming as time passes? The answer is his list of the stages (*Taste and Fashion*, p. 258) undergone in the decay of chic.

Indecent: 10 years before its time  
Shameless: 5 years before its time

Outré (daring): 1 year before its time  
 Smart  
 Dowdy: 1 year after its time  
 Hideous: 10 years after its time  
 Ridiculous: 20 years after its time  
 Amusing: 30 years after its time  
 Quaint: 50 years after its time  
 Charming: 70 years after its time  
 Romantic: 100 years after its time

Laver encountered more serious intellectual difficulties in explaining the objective shifts in dress styles. As he investigated forms of attire such as uniforms and professional dress, he realized that not all clothing changed at the same rate. To explain these different rates of change or, in some cases, their complete absence, he began to supplement his ideas about the relation between zeitgeist and dress with those of Thorstein Veblen and J. C. Flügel.

When Laver published his book *Dress* in 1950, he explained changes in dress styles using a version of the “three motives” model of the nineteenth century. Laver argued that clothing both expresses and is shaped by three fundamental principles: the hierarchical principle, the attraction or seduction principle, and the utility principle. The seduction principle plays the most significant role in fashion change, particularly as it affects women’s clothes. Laver theorizes that the seduction principle is the most important because “our clothes are dictated by the fundamental desires of the opposite sex.” (1950, p. 15). He goes on, “Men still choose their mates by their physical allure; that is why women’s clothes follow what might be called the Attraction Principle; they are designed to make their wearers as physically attractive as possible” (1950, p. 15).

Women, according to Laver, have to compete with one another through their appearance, and wherever there is sartorial competition there will also, he argued, be fashion.

See also **Fashion, Historical Studies of; Fashion Museums and Collections; Flügel, J. C.; Veblen, Thorstein.**

#### BIBLIOGRAPHY

- Works by James Laver*  
 “Triumph of Time.” In *Contemporary Essays: 1933*. Edited by Sylva Norman. London: Elkin Mathews and Marrot, 1933.  
*Nostradamus; or, The Future Foretold*. London: Collins, 1942.  
*Taste and Fashion from the French Revolution until To-day*. London: G. G. Harrap and Company, Ltd., 1937. New revised edition titled *Taste and Fashion from the French Revolution to the Present Day*, 1945.  
*A Letter to a Girl on the Future of Clothes*. London: Home and Van Thal, 1946.  
*Style in Costume*. London: Oxford University Press, 1949.  
*Dress: How and Why Fashions in Men’s and Women’s Clothes Have Changed during the Past Two Hundred Years*. London: John Murray, 1950.

*Museum Piece; or, The Education of an Iconographer*. London: Andre Deutsch, 1963.

#### *Works about James Laver*

Carter, Michael. “James Laver: The Reluctant Expert.” In *Fashion Classics from Carlyle to Barthes*. New York and Oxford: Berg, 2003.

Michael Carter

**LAWN.** See **Cambric, Batiste, and Lawn.**

**LEATHER AND SUEDE** Leather is animal skin that has been processed in various ways (generically known as tanning) to preserve and soften it for use in clothing, accessories, and other applications. Suede is a special type of leather in which the inner surface of the skin is processed to produce a pleasing texture.

#### History

Leather as a medium to create clothing dates back to Cro-Magnon man some 50,000 years ago. Around that time, early humans began to migrate from relatively warm regions of the earth to the more northerly and colder parts of the northern hemisphere. Although prehistoric people learned that animal skins could be used to keep warm, they would have encountered difficulties in using untreated skins: when dried, animal skins get stiff. Among the many discoveries made by our ancient ancestors, the preservation (tanning) and processing of animal skins was one of the most important to their survival. They did this through a variety of means, such as boiling the skins in tree bark and then salting them. Almost all preservation techniques concluded with rubbing the skins with animal fat to soften them, and bending and working the skins (or chewing them) until they became soft. This would render the skins soft enough so that they could be comfortably worn and tied around the body. Later, bone tools (such as needles and awls) were developed so that skins could be sewn together to create clothing.

As far back as the fifth to the third millennium B.C., there is evidence that women wore garments made of leather in Sumeria and Mesopotamia. An almost perfectly preserved gazelle skin loincloth dating from 1580–1350 B.C.E. was found in Egypt. There are also numerous references to leather found in the Bible. Tanneries were uncovered in the ruins of Pompeii.

While animal skins were usually tanned for the purpose of showing off the skin’s “grain” (outer) side, eventually it was discovered that otherwise unusable skins (e.g., grain sides were scratched) could be salvaged by processing the inside of the skins. Such “inside-out” leather was the forerunner of suede.

Over time, many countries, such as Spain, England, and France, began to perfect their own tanning tech-





**Versace leather dress.** In the 1980s, many top designers began working with leather, and it has become a lucrative industry, garnering over \$14 million a year by the early 2000s. © VAUTHEY PIERRE/CORBIS. REPRODUCED BY PERMISSION.

niques. These sometimes included novel refinements; for example, during the seventeenth century, the French would cover up the disagreeable odor left on skins after tanning by bathing the skins in perfume.

In North America, Native Americans introduced early European settlers to the technique of oil tanning. American Indians made tepees out of leather and decorated their leather clothing with beads, bones, porcupine quills, and feathers. They also painted their garments with elaborate battle scenes. Through their exceptional tanning skills, they were able to produce white leather, a particularly difficult color to achieve.

During the nineteenth century, Augustus Schultz, an American chemist, invented a newer, faster method of tanning using chromium salts. This innovation made it possible to reduce the tanning process from weeks and months to hours. Engineers in America and Europe began to invent special machines and processes that further increased tanning productivity. By 2004, tanneries around the world closely guarded proprietary techniques to give themselves a competitive advantage. Many tanneries are

exploring the eco-friendly method of vegetable tanning, using extracts from quebracho wood and chestnut.

Designers throughout history have regarded leather as having a certain allure. From the earliest decorated ceremonial garments worn by tribesmen to high fashion couture collections, the wearing of leather has been synonymous with status. Because of the high cost and craftsmanship involved in the processing of leather, leather represents “luxury.”

Leather has also been used for thousands of years to make sandals and shoes. In addition, it has had important industrial uses, for example to make drive belts for industrial machinery.

### The Processing of Leather

Leather, for the purpose of apparel manufacturing, is a byproduct of food consumption. The animals that are consumed for food and that are most often used for clothing are: cow, goat, sheep, lamb, pig, and deer. Leather is processed by a tannery. A tannery is a factory that buys raw skins from an abattoir, makes the skins into leather, colors them, and then sells them to manufacturers. Animal skins come from all over the world and tanneries are located worldwide.

“Hides” (the pelt of large animals such as pig, deer, and cow) and “skins” (smaller animals such as goat, sheep, and lamb) are delivered to the tannery de-haired, either in a preserved dried state or in a preserved “pickled” state (i.e., chemically treated with various salts, water, and sulfuric acid). These treated hides and skins are referred to as crusts. Crusts, which are dried to a boardlike state, can be stored for several months before tanning.

Tanning is a process that is dependent on several factors: the type of skin, the desired end use, and the price the buyer is willing to pay. By using specific amounts of fat liquors, chromium salts, and other chemicals or vegetable tannins, tanneries can formulate a recipe that can create a soft, subtle expensive skin. Or by cutting out certain steps, they can produce a less expensive skin. Color can be added to skins by either adding it to the drum after tanning to produce aniline skins, or for skins of lesser quality, color can be sprayed onto the surface of the skin to produce semi-aniline skins. In the case of extremely poor quality skins, color can be applied in heavier concentrations in an attempt to hide imperfections. These are called pigmented skins. Pigmented skins are generally hard to the touch.

Leather skins can be processed utilizing different sides of the skin. When a leather skin is de-haired and tanned with the grain side out, it produces a smooth finish known as nappa. When the underside of a leather skin is buffed, it produces a velvety nap known as suede. In 1809, a leather-splitting machine was invented that could split heavy leathers to any desired thickness, producing skins known as splits, which are sueded on both sides. Cow and pig splits are less expensive than processing single-

sided lamb and goat suede. The grain side of leather can also be processed to create a napped finish known as nubuck, however, this is not considered true suede.

At the tannery, skins are sorted to choose which skins will be made into suede and which will be chosen for nappa. Suede can be made from relatively lower-quality skins than nappa; however suede requires several more processing steps. The animals most often used to create garment weight suede are: lamb, sheep, goat, pig, and cow. Suede produces a nap similar to velvet and corduroy, therefore care must be taken when cutting suede into garments as color shading will occur if not properly cut. While nappa skins are generally more expensive than suede, the higher material consumption, due to cutting loss while shading, usually results in equal pricing at the retail level.

### Leather Innovation

Tanneries throughout the world are constantly inventing new recipes to tan and color skins to achieve a competitive advantage over their peers. Tanneries guard their recipes and special techniques for processing leather. By working together with fashion designers, tanneries often create many innovative production techniques. Stamping, embossing, distressing, tie-dyeing, pleating, printing, beading, flocking, perforating, and embroidery are only some of the special techniques that designers have created to make leather skins even more spectacular.

Designers throughout the years have used leather much the same as they would cloth. From its main use in outerwear and sportswear, to the most elaborate evening-wear, designers have always appreciated the uniqueness of leather. Leather items such as the aviator jacket worn by General Patton in World War II and the black leather jacket worn by James Dean in the 1950s have created important trends in the fashion world. From the 1960s through the 1970s, American designer Bonnie Cashin worked extensively in leather. European designers such as Claude Montana, Versace, Armani, Ungaro, Fendi, Gucci, Alaïa, and Hermès took the lead in leather apparel design through the 1980s. By the mid- to late 1980s, many of the top American designers also discovered leather's limitless possibilities, such as Ralph Lauren, Calvin Klein, Geoffrey Beene, Donna Karan, and Bill Blass.

In 2004, leather garments could be found at all price points, from the most expensive leathers used in couture to skins used in the production of mass-market clothing.

### Suede Innovation

Clothing made of suede is more fragile and harder to keep clean than non-suede leathers. This is because suede tends to absorb stains. Wearing suede is considered a luxury and a symbol of status. Designers throughout history have used suede for its beauty. Many designers prefer suede to work in, especially when they are designing soft, drapey, fluid styles. Suede is used much the way a designer would use cloth. Suede can be draped, pleated, gathered, and fluted. In 1930, the French designer Paquin

created a suit using goat suede and wool. Cow-slit was used by Hermès in 1957 to create a coatdress and also by Bonnie Cashin in her suede ensemble from the 1960's. Suede is also a favorite among couturiers, as demonstrated in Givenchy's suede patchwork suit from Couture Collection 1992 and Jean Paul Gaultier's suede-draped tunic from his Couture Autumn/Winter Collection 2002.

Designers often work with tanneries to develop innovations in suede such as reversible and double-faced skins, embossing to resemble hides of endangered animals, and in the creation of new perforating techniques.

### Social and Political Issues

The animal-rights organization known as People for the Ethical Treatment of Animals (PETA) has a history of attacking the leather apparel industry as well the fur industry. Though they acknowledge that most leathers used in apparel are made from the byproducts of food consumption, they have accused manufacturers in developing countries of inhumane slaughtering processes as well as using toxins in the tanning of leather.

The Leather Apparel Association (LAA) is a trade association representing leather manufacturers, cleaners, suppliers, tanners, and retailers nationwide. The mission of the LAA is to continually monitor and improve the health and future of the leather apparel industry and provide support against PETA. The Leather Industries of America (LIA) is another organization that represents tanneries, sellers, and other leather-related companies. The LIA provides technical, environmental, educational, statistical, and marketing services to its members and the public.

Even with numerous attacks by PETA, the leather apparel industry remains a \$14.5 million global industry. As appeal for leather clothing continues, the leather industry seeks new eco-friendly methods to process leather. Although leather apparel experiences trend cycles, it most definitely remains in 2004 a desirable commodity in the world of fashion.

See also **Cashin, Bonnie; Handbags and Purses.**

### BIBLIOGRAPHY

Sterlacci, Francesca. *Leather Apparel Design*. New York: Delmar Publishing 1997.

#### Internet Resources

Leather Apparel Association. 2004. Available from <<http://www.leatherassociation.com>>.

Leather Industries of America. 2004. Available from <<http://www.leatherusa.com>>.

PETA. 2004. Available from <<http://www.peta.org/mc/facts/fsveg.html>>.

Worth Global Sourcing Network. 2004. Available from <<http://www.WGSN.com>>.

*Francesca Sterlacci*

**LEGAL AND JUDICIAL COSTUME** Legal and judicial costume is defined as special occupational dress worn by judges and members of the legal community to mark their membership in this professional group.

### Dress in the Early Modern Period

Legal and judicial dress has its origins in royal and ecclesiastical history. Prior to the early modern period, monks and other ecclesiasts were responsible for the administration of justice in the European territories. By the fifteenth and sixteenth centuries, this group was replaced by lesser nobility appointed by European sovereigns. As direct servants of the monarch, they were charged with the administration of sovereign law, and it was important for their clothing to reflect the legitimacy and authority of the sovereign's rule. Therefore, early judicial and legal dress borrowed heavily from the styles of the church's legal representatives, while reflecting the new era now defined by royal rule.

### Judicial Dress

During the fifteenth and sixteenth centuries, judicial dress varied considerably between nations due to the decentralization of ownership and rule in Europe. Ecclesiastical costume history, however, assured some general similarities in basic judicial and legal dress among European nations. Judges of the early modern period wore sleeved tunics, and over this, wide-sleeved pleated gowns or robes made from cloth, wool, or silk. This garment, previously worn by monks, was sometimes referred to as a *supertunica*. High judges might wear tabards (essentially, a sleeveless version of the supertunica) instead. Judges also wore closed mantles covering the shoulders to the middle-upper arm, and rolled hoods or casting hoods of the same fabric, lined with miniver. For ceremonial occasions, some judges wore a shorter cloak, called an *armelausa* (in France, called a *manteau*), made from the same fabric.

Despite this basic attire, there was little consistency in color of judicial uniform. James Robinson Planché summarizes this point well in his *Cyclopaedia of Costume*: "Information respecting the official costume of the Bench and the Bar is abundant; but, unfortunately, the descriptions are not so clear as they are copious" (Planché, p. 426). Royalty frequently dressed judges in ornate, regal costumes of scarlet and black, although vibrant hues of pink, violet, and royal blue were also common. Color reflected royal taste, but also judicial rank or position, and lower judicial officials wore different colors than presiding judges. Justices of the peace, appointed on a local basis to police the king's laws and manage local affairs, wore lay dress associated with their middle-class rank.

Upon the head, members of the early modern judiciary typically wore a coif, a white circular lawn or silk cap, along with a black silk or velvet skullcap on top. Such head coverings bore resemblance to academic dress, which signified the possession of a doctorate degree. In

fact, "The Order of the Coif" was a name given to a group of British sergeants-at-law, a special legal class who comprised the body from which high judicial offices was chosen. Judges often wore another hat on top of the coif and skullcap, particularly in France and Germany.

### Early Legal Dress

Early costume for lawyers, also known as barristers, solicitors, advocates, or councillors, depending on the country, bore strong similarities to that of judges. During the Middle Ages, lawyers were considered to be apprentices to the judiciary, which explain the likeness in dress. Like their judicial counterparts, barristers in Britain also wore closed gowns made of cloth or silk. These garments, however, had raised, stuffed shoulders and elbow-length glove sleeves. Even before Queen Mary's death, these gowns were predominantly black, in accordance with the rules of the Inns of Court that organized barrister education and membership. Like judges, barristers also wore coifs and skullcaps, as well as white ruff-like bands around the neck. Solicitors, who unlike barristers, did not have the right to present in court, wore long, open black gowns with winged sleeves, although by the seventeenth century, they had lost their special dress and instead wore common business attire. French advocates wore wide, colored, bell-sleeved gowns, often in scarlet, with shoulder pieces and chaperons like their judicial counterparts. They also wore white bands and stiff black toques called *bonnets carrés*.

### Regulations of the Seventeenth Century

Historically, monarchs set out complex dictates on judicial and legal dress, which reflected that individual sovereign's taste. By the seventeenth century, as countries continued to centralize and codify legal order, it became important to systemize the mélange of customs and traditions relating to legal and judicial dress. This did not, however, result in a simple, concise, framework for dress—in fact, the exact opposite! In 1602, France regulated, by royal mandate, the dress of its judges and lawyers of all ranks. Although scarlet still predominated, the monarchy dictated the specific robe fabrics, colors, and lengths for its judges, advocates, and clerks. It even made distinctions for colors by seasons and days of the week.

Britain had similarly intricate legislation, which resulted in complicated and confusing dictates. According to the 1635 Decree by Westminster, the monarch became the exclusive administrator of judicial dress. From spring to mid-autumn, it was mandatory for judges to wear a taffeta-lined black or violet silk robe with deep cuffs lined in silk or fur, a matching hood, and a mantle. Judges were also required to wear coifs, caps, and a cornered cap on top. During the winter months, the taffeta lining was replaced with miniver to keep judges warm. Special scarlet dress replaced this standard costume on holy days or the visit of the Lord Mayor.

There was no parallel code for barristers' dress at this time, and the Inns of Court governed bar costume.





### WHY JUDGES WEAR BLACK

Free use of color in judicial dress lasted in European countries until the late seventeenth century, when the black robe, which many consider to be the traditional judicial color, became the preferred color for daily judicial dress. France adopted black as the color of undress for its judges, and historians believe that the British tradition of black robes began when barristers and judges adopted mourn-

ing dress for Queen Mary II in 1694. Although high court judges eventually reverted back to colors of scarlet and violet, it remained for barristers, lower-court judges, and court clerks in Britain. By the eighteenth century, American judges had followed suit, though as a symbol of liberty from British control over the American colonies, and an affirmation of Victorian values of dignity and propriety.

During the same time, Britain also regulated the judicial dress of the American colonies. Settlers followed codes and ceremonies of British law, and while little has been written on judicial and legal dress in the colonies, scarlet, which was the ceremonial and traditional color for British judges, was *de rigueur* for the colonial bench. American dress, however, did not mirror the same level of British complexity, given the puritan and austere circumstances and culture of the region.

#### Adoption of the Wig

Even the dignified and traditional dress of the legal and judicial system has not been isolated from whims of popular fashion. The wigs worn by members of the British bench and bar are perfect examples of this idea. Fashion has always influenced its styles, from changes in sleeve to ruffs and sashes. Charles II imported the wig from France in 1660, and during the seventeenth century, they were a fashionable item for all gentlemen of wealthy and established social classes. Made from human or horsehair, they sat very high at the crown, and cascaded in curls over the shoulders. Judges and barristers took to wearing these fashionable full-bottomed wigs with their robes, no doubt under the recommendation of Charles II. By the middle of the eighteenth century, wigs fell out of favor with the general public, but legal professionals adopted the wig as a vital part of the legal and judicial uniform. In the early 2000s, high-court judges and the Queen's Counsel in Britain and the Commonwealth continue to wear full-bottomed wigs for ceremonial occasions, and shorter bench wigs are customary for daily courtroom proceedings. Barristers wear an even more abbreviated version of the seventeenth-century wig, known as a tie-wig, which sits back from the forehead to expose the hairline.

#### Legal Dress in the Early 2000s

The styles put into place in the seventeenth century for the legal and judicial community have persisted in their basic form, although styles for sleeves, collars, and accoutrements like wigs and bands have changed, accord-

ing to lay fashion and monarchial taste. Central governments rather than monarchs regulate legal and judicial dress, and complex and confusing directives, in principle, continue to exist. In Britain, judges, barristers, and court clerks sitting in high courts are generally required to wear black silk or stuff gowns over suits, and a short bench or tie-wig and bands. Black robes for judges account for more of their dress than in previous times, and high court, district, and circuit courts prescribe their use all or much of the time.

More frequently, colored mantles or sashes denote the type of case and court a judge presides over. Scarlet robes remain reserved for ceremonial occasions, as well as for some high-court criminal cases in winter. Violet is also used for certain cases according to season and court. Judges may be called to add or remove cuffs, scarves, mantles, and hoods of varying color and fabric at different times and seasons. These rules, however, are frequently amended and discarded in practice by judges in particular, who may dispense of their wigs or robes, either due to weather or due to special circumstances, such as cases involving children. Barristers' dress remains more clear-cut, and in court they continue to wear black silk or cloth gowns, tie-wigs, and bands, depending on the seniority of their position. Solicitors and lower court officials do not wear wigs. Justices of the Peace, now predominantly confined to name only, do not wear any special dress.

Like Britain, France has also retained its complex guidelines for members of the legal profession. French high court judges traditionally wear bell-sleeve cloth or silk black gowns and heavy draped manteaus lined with rabbit fur. Over the coat, they also wear fur shoulder pieces upon which they hang national medals. Like Britain, this full dress is not always abided by in daily practice. For ceremonial occasions, high-court judges may wear scarlet robes. Lower-court judges wear similar robes in black or scarlet with black satin cuffs. Unlike their British or American peers, these robes button down the front, and have trains that can be tucked up inside the robe. Additionally, they wear black moiré belts and

*epitoges*, or shawls tipped in ermine or rabbit, along white cloth fichus. They also continue to wear black toques. Although French advocates wear business attire outside of the courtroom, they still wear black robes like their lower court judicial counterparts in court trials. They can, but rarely do, wear toques as well. French court clerks wear dress similar to advocates, but this depends on the formality and level of the court.

Other European countries follow similar national judicial-costume history, and even the European Community's high judges wear distinctive scarlet or royal blue judicial robes, although this is governed by tradition rather than written statute. Lawyers and advocates presenting at the European Courts of Justice wear their national legal costume, whether it be plain dress or robe.

Unlike in Europe, both national and local governments regulate judicial and legal dress in the United States, and American legal costume is confined only to judges. All levels of the judiciary wear long, black, cloth or silk gowns with bell-sleeves and yoked necklines. They wear no wig, special headdress or collar, although male judges are expected to wear a shirt and tie underneath their robes. There is no specific dress code for court clerks appearing in courts, although professional dress is assumed or required. Justices of the Peace, now largely succeeded in authority by organized lower-level courts, wear lay dress as well.

### Production and Retailing

Legal and judicial dress is produced by specialized manufacturers and sold through specialty legal retailers or by companies that also cater to academic and religious vestments. Legal dress can be quite expensive, and in Britain, a black judicial gown may cost between £600 (\$960) and £850 (\$1,360), and a full-bottomed judicial wig, £1,600 (\$2,560). Such expenses have actually resulted in a thriving market for used wigs in Britain. Some high-court judges in Britain and other European countries are given a stipend for their judicial attire, but lower-court judges, barristers, and advocates, must provide for their own. In America, judges are expected to pay for their judicial dress, but pricing is far more moderate.

### Modernization

There has been considerable debate since the mid-1980s about the relevance of traditional legal and judicial dress in modern society. The United States and many European countries have relaxed regulations regarding such attire, particularly for judges, and judges have had the ability to exercise their individual judgment in such matters. Judges in Britain have chosen to disband with wigs and robes upon certain situations when they want to convey a feeling of equality to laypersons, and Muslim and Sikh judges wear their turbans instead of wigs.

Modernization has also included the exercise of individual judicial tastes as well. In 1999 American Supreme

Court Justice William Rehnquist chose to wear a robe decorated with gold stripes on each sleeve at the Impeachment Trial of President William Jefferson Clinton in 1999. Justice Byron Johnson of the Idaho Supreme Court in the United States chose to wear a blue robe, rather than a black one when he sat on the bench. Although both examples are American, they reflect the questioning of relevance of judicial and legal dress in the early twenty-first century, and how it relates to the role of judges and lawyers in community organizations.

Another example of modernization is the ongoing debate regarding the relaxation of legal and judicial garb in the United Kingdom, and specifically the abolishment of wigs. In 1992, and again in 2003, the judicial system in Britain debated the redesign of judicial and legal dress in order to be more relevant to society. With this has come the question of whether to retain the wig.

In addition to being a visual guide for members of the legal profession to that of their peers, the image of judges and barristers in their traditional occupational dress for society reminds the public of the dignity and gravity of the law, and the impartiality of the judicial system. It also acts as a disguise to protect judges and barristers outside of the courtroom, as well as a tool for downplaying differences in age and gender. Hence, the decision to retain, relax, or disband with legal and judicial dress, extends beyond a discussion of the physical garments. Current debates about judicial dress are also deliberations over the function of governments and tradition in the structure of civil life, and the role of a judicial representative in the modern execution of justice.

See also **Royal and Aristocratic Dress.**

### BIBLIOGRAPHY

It should be noted that there are very few books devoted to legal and judicial dress, and even fewer incorporating issues of modernization. Information can often be found in the occupational dress section in general costume histories, but books specifically dedicated to the history of judicial and legal practice too often omit dress from discussions. History journals and legal journals have been the most helpful sources, and information covering Britain and America are most predominant. Journals documenting parliamentary discussions and debates are also useful as primary source material.

Hargreaves-Mawdsley, W. N. *A History of Legal Dress in Europe until the End of the Eighteenth Century*. Oxford: Clarendon Press, 1963. An indispensable authoritative book of European legal dress before the eighteenth century.

MacClellan, Elisabeth. *Historic Dress in America, 1607–1870*. Philadelphia, Pa.: George W. Jacobs and Co., 1904. Good for judicial dress and history in the American colonies.

O'Neill, Stephen. "Why Are Judges' Robes Black?" *Massachusetts Legal History: A Journal of the Supreme Judicial Court Historical Society* 7 (2001): 119–123. Very useful for American dress.

Planché, James Robinson. *Cyclopædia of Costume or Dictionary of Dress*. Volume 8: *The Dictionary*. London: Chatto and Windus, Piccadilly, 1876. Very helpful as a detailed source of

early legal garments, given the confusing nature of the dress. Extensive reference to primary sources.

Webb, Wilfred M. *The Heritage of Dress*. London: E. Grant Richards, 1907. Good discussion about the history and vestiges of early legal dress.

Yablon, Charles M. "Judicial Drag: An Essay on Wigs, Robes and Legal Change." *Wisconsin Law Review*. 5 (1995): 1129–1153. Lively, entertaining article encompassing the history, political and sociology behind judicial dress. Worth tracking down.

Leslie Harris

**LEIBER, JUDITH** Judith Peto was born in Budapest, Hungary, where she and her family survived World War II and the Holocaust. In 1946 she married Gerson Leiber, a Brooklyn-born American soldier serving in Budapest, and returned with him to the United States the following year. (He later became well known as an artist of the New York school.) She spent the next sixteen years working for several handbag companies, moving up the ladder from machine operator to designer, before she and her husband founded Judith Leiber, Inc., in 1963. The company became highly successful, and Mrs. Leiber's bags were avidly sought after by a growing list of clients. They sold the company in 1993, with Mrs. Leiber remaining as president and chief designer for several years thereafter; later she became a consultant to the company. She retired in 1998.

Judith Leiber's name is synonymous with a particular type of evening bag known as a minaudière. Minaudières (the name comes from a French word that means "to be charming") are small evening bags made of metal or other rigid materials and that usually have highly decorated or bejeweled surfaces. They often are fanciful or whimsical in design and can take the form of plants, animals, or trompe l'oeil objects. Minaudières, which first appeared as fashion accessories in the 1930s, have been made by a number of designers, but Judith Leiber is by far the best-known designer and manufacturer in the field. Her company has produced minaudières in hundreds of different designs, usually in very limited editions.

One of Leiber's best known designs is a bag in the shape of a ripe, red tomato, covered with thousands of hand-set red and green crystals. Each bag is handcrafted and requires several days to complete. A model is sculpted in wax and then cast in metal using the *ciré-perdu* process. The bag is then gold-plated, painted with a surface design, and covered with rhinestones, crystals, or other hand-set, faux gemstones. Other typical designs have included a white, pearl-beaded teddy bear, a slice of watermelon, and a variety of eggs.

Though Judith Leiber is best known for minaudières, she has also designed and produced a wide range of other luxurious bags. She is well known to her wealthy clientele for both day bags and evening bags, fashioned in al-

igator and other leathers, as well as in velvet, silk, and other fabrics, and often graced with crystal-encrusted metal handles and closures. Minaudières and other handbags by Judith Leiber are avidly collected by connoisseurs. They have been widely imitated and counterfeited, but the craftsmanship and art of the originals remain unmistakable.

See also **Handbags and Purses**.

#### BIBLIOGRAPHY

Nemy, Enid. *Judith Leiber: The Artful Handbag*. New York: Harry N. Abrams, 1995.

#### Internet Resource

Judith Leiber. Website 2004. Available from <<http://www.judith-leiber.com>>.

Valerie Steele

**LEOTARD** In January 1943, *Harper's Bazaar* hailed the leotard as "a new idea, leading toward the twenty-first century and the cosmic costumes of Flash Gordon's supergirl" (p.35). That same year's August issue urged college girls to "be the first to wear the leotard under your wool jersey jumper, a silhouette new from the ground up, a fashion so honest and sound it's bound to be a classic" (p. 65). In September of that year, *Life* magazine featured these "strange-looking garments" on its cover, declaring that "'Leotard' is a new word in fashion parlance" (p. 47).

The leotard may have been new to fashion, but it had been pioneered some eighty years before by Jules Leotard, a French gymnast who invented the flying trapeze in 1859. To show off his figure during daring aerial performances, he wore a short, close-fitting garment, cut low in the neck and gusseted between the legs. By the late nineteenth century, the worsted-wool or silk garment that acquired his name was standard wear for acrobats and gymnasts. In the early twentieth century, the leotard with tights was also the traditional rehearsal costume for ballet dancers and increasingly preferred as modern dance-performance costume. This stylized form of nudity—starkly anonymous or with minimal accessories—accentuated the line of bodies in motion in works by innovators such as Serge Diaghilev, Martha Graham, and George Balanchine.

As wartime fashion for co-eds, the leotards designed by Mildred Orrick and Claire McCardell could be snug, two-piece, wool-jersey garments with long legs, long sleeves, and high necks. Made in many colors or vividly striped, they were worn with sleeveless jumpers, skirts, or evening pants; underneath, according to *Harper's Bazaar*, went a brassiere and garterless pantie-girdle—or nothing at all.

The freedom given by leotards was appreciated in the 1960s by hip young women and by designers includ-



ing Rudi Gernreich, a former dancer, as the modern concept of “body clothes” emerged. By the late 1970s, advances in technology gave active sportswear maximum comfort and fit. Made of stretchy nylon and spandex, a leotard and tights became the basic fitness fashion, sanctioned by Jane Fonda in her influential *Workout Book* of 1981. By 1985, comedian Dave Barry, in *Stay Fit and Healthy Until You’re Dead* could joke that this outfit encouraged women to exercise extra vigorously since it “shows every bodily flaw a woman has, no matter how minute” and to refrain from drinking, since “there is no way to go to the bathroom in a leotard and tights.”

In the body-conscious late 1970s and 1980s, many forms of the leotard—also known as the bodysuit, mail-lot, catsuit, unitard, body stocking, or bodytard—were everywhere or the disco or roller disco; according to the 1980 book *Sportfashion*, leotards “stretching and moving to the beat of the music” (p. 137) adopted shimmering fabrics, Day-Glo colors, sequins, and rhinestones. The versatile garment was also seen as perfect on the beach, in town, and at the office, as dancewear companies Danskin and Capezio and designers such as Betsey Johnson made the leotard the basis of a wardrobe of separates that were “interchangeable, washable, packable, seasonless, timeless, ageless” (p. 142). To the late twentieth century, the leotard still seemed “the first dressing concept worthy of the twenty-first century” (p. 116). In the new millennium, now sometimes simply called a “body,” it continues to be a streamlined second skin.

See also **Ballet Costume; Elastomers.**

#### BIBLIOGRAPHY

- Adler, France-Michèle. *Sportfashion*. New York: Avon Books, 1980.
- Strong, Roy et al. *Designing for the Dancer*. London: Elron Press, 1981.

H. Kristina Haugland

**LESAGE, FRANÇOIS** François Lesage, a French embroiderer born in Chaville in 1929, is the son of Albert Lesage (1888–1949), founder of Albert Lesage and Company in 1924, and of Marie-Louise Favot, known as Yo, a designer for Madeleine Vionnet. After an apprenticeship in the family firm in Paris, François Lesage went to the United States in 1948 and opened a shop on Sunset Boulevard, Los Angeles, where he embroidered for dressmakers and Hollywood studios, but the death of his father the following year put an end to his American adventure. François Lesage returned to Paris to assist his mother in managing the renowned company.

#### History

At the time of his father’s death, the embroidery house that Lesage inherited was among the most important and prestigious specialty companies of its type in the world.

In 1924 his father, Albert, had taken over the business of the embroiderer Michonet. Michonet’s venerable firm, which was founded in 1858, had supplied the great names of couture of the belle époque (Charles Frederick Worth, John Redfern, Jacques Doucet, Callot Soeurs) with beautiful embroidery to decorate their creations. The firm had also supplied the imperial court of Napoleon III with embroidery and had succeeded in establishing new connections with the talented generation of couturiers between World War I and World War II. François Lesage was thus familiar from a very young age with the technical and aesthetic feats accomplished by his parents for the original collections of Madeleine Vionnet and Elsa Schiaparelli, among others.

When he took charge of the firm, which possessed tens of thousands of samples, the young François continued the craft tradition and created his own collections of samples, which were immediately admired by such designers as Pierre Balmain, Cristóbal Balenciaga, Robert Piguet, Jacques Griffe, and Jean Dessès. For the *jolie Madame* (the trade name of Pierre Balmain), full of grace and delicacy expressed in muted tones, he updated the rococo ribbon. The artificial flowers, straw spangles, and planished sequins to be found in the work of several couturiers of the time are early examples of the style of the young Lesage, a subtle mixture of tradition, novelty, and a bold approach to every challenge.

#### Innovations

François Lesage freed himself from the weight of tradition in the 1960s. He successfully experimented with new materials, including patterns of plasticine and cellophane, bold treatments of classic materials, and uncommon arrangements that revealed a different approach to relief. Embroidery had become fabric, and fashionable dresses, cut straight and not fitted to the body, offered an ideal setting for Lesage’s graphic compositions, which covered the entire surface of the design. Lesage acquired new clients, including such stellar names as Lanvin, Givenchy, Dior, Grès, Patou, and Yves Saint Laurent.

#### Work with Haute Couture

In the 1970s Lesage designs returned to the thematic collections that had been favored by Schiaparelli. Yves Saint Laurent was the first designer to recognize the aesthetic potential of this change. The entire industry, stimulated by lavish orders from Arab princesses, followed Saint Laurent’s lead and kept the embroidery workshops operating overtime. Lesage developed embroidery on jersey and new techniques, such as precut designs attached by thermoplastic films to fabrics. In 1977 he embroidered the court dress of the wife of Jean Bedel Bokassa, which was ordered from Lanvin on the occasion of the coronation of Bokassa to the office of emperor of the Central African Empire.

In 1982 Lesage began to collaborate with the American designers Calvin Klein, Bill Blass, Geoffrey Beene,

and Oscar de la Renta. Throughout the decade thematic collections provided opportunities for creation and innovation. Lesage established fruitful dialogues with Yves Saint Laurent; as well as with Karl Lagerfeld, the new artistic director of Chanel and Christian Lacroix, with whom he collaborated from the opening of his couture house in 1987. While Lacroix was still at the house of Patou, he met Lesage, whom he considered his “godfather in fashion.” For all these designers, who competed with one another in erudition and historical references, Lesage revisited the entire history of art, producing masterpieces for each of them that required hundreds of hours of work. Among the most famous of his productions transposed Van Gogh’s irises and sunflowers onto Yves Saint Laurent jackets in 1988, a feat requiring no fewer than six hundred hours per jacket.

### Accessory Line

Encouraged by this infatuation with the magic of embroidery, Lesage launched a line of embroidered accessories in 1987, created by Gérard Trémolet and sold in the Lesage boutique opened that year on the Place Vendôme on the former site of Schiaparelli’s business. After the shop closed in 1992, the accessories were sold in department stores around the world.

### Legacy

In 1990 Lesage joined the Comité Colbert; in 1992, in order to perpetuate his art and transmit his skill, he opened the Lesage School of Embroidery at the address of his workshop, 13 rue de la Grange Batelière in Paris.

Having attained the summit of his art, Lesage became the subject of several one-man shows: at the Fashion Institute of Technology in New York (1987), at the Musée de la mode et du costume Palais Galleria in Paris (1989), at the Fashion Foundation Hanae Mori of Tokyo (1989), and at the Los Angeles County Museum of Art (1991).

With the 1990s came an influx of new orders from creators such as Thierry Mugler and Jean Paul Gaultier, who launched their own haute couture activities. But also, paradoxically, orders for ready-to-wear clothes from houses and designers such as Chanel, Dior, and Yves Saint Laurent added to the work of the embroiderers working under Lesage.

In addition to the work done for designers, Lesage has carried out many special orders. For example, on the occasion of the World Youth Days in Paris (1997), he embroidered the chasuble and miter of Pope John Paul II. Additionally, he embroidered the costumes of Erik Orsenna and Roman Polanski for their entry into the Académie française (1999) and costumes for the new revue at the Moulin Rouge (1999). Lesage followed the long tradition of the house in working for royalty when he collaborated with Moroccan craftsmen and designed costumes for the trousseau of the bride of Mohammed VI in 2001. In 2002 the Lesage company was acquired by

Chanel as part of its Paraffection group, bringing together craftsmen of elegance who possess exceptional skill.

*See also* **Beads; Embroidery; Spangles.**

### BIBLIOGRAPHY

- Kamitsis, Lydia. *Lesage*. (Paris: Editions Assouline; New York: Universe/Vendome, 2000).
- White, Palmer. *The Master Touch of Lesage: Embroidery for French Fashion*. Paris: Chene, 1987.
- . *Haute Couture Embroidery: The Art of Lesage*. New York: Vendome Press, 1988.

*Lydia Kamitsis*

**LEVI STRAUSS & CO.** The name Levi Strauss is indelibly linked with a quintessential American fashion—blue jeans. The original riveted work pants, called “waist overalls,” were patented by Levi Strauss in 1873 and became staples of quality, durable workingmen’s garments for more than fifty years. In the 1950s blue jeans, particularly Levi Strauss classic riveted “501’s” emerged as fashion statements, anticipating the skyrocketing popularity of denims worldwide in the following decades. The dominance of Levi’s in this fashion phenomena transformed Levi Strauss & Co. from a successful regional company into one of the world’s largest clothing brands, with \$4.1 billion in total sales in 2002.

While Levi Strauss & Co. has aligned itself more closely with style and fashion in the twenty-first century, its origins were humble and rooted in the dry goods trade. Its founder, Levi Strauss, was born “Loeb” Strauss in Buttenheim, Bavaria, in 1829, one of seven children of Hirsch Strauss. In 1847, Loeb Strauss emigrated to the United States to join his stepbrothers, Jonas and Louis, owners of a dry-goods business in New York City. Loeb quickly learned the family trade and by 1850 he had changed his name to Levi.

The discovery of gold in California and the subsequent Gold Rush of 1849 brought throngs of fortune hunters west in the hopes of striking it rich. In 1853, Levi Strauss headed to San Francisco, too, not to pan for gold, but to establish his own dry-goods business catering to this new workforce.

Levi Strauss set up his wholesale business selling bolts of cloth, linens, and clothing at 90 Sacramento Street, close to the waterfront for convenient access to goods coming off ships. In the late 1850s and early 1860s, his enterprise, known merely as “Levi Strauss,” profited, and its steady expansion forced him to relocate several times to other waterfront addresses. In 1863 his brother-in-law, David Stern, joined his firm, and the company was officially renamed Levi Strauss & Co. By this time, Levi Strauss was in his thirties and the firm was a profitable entity providing a variety of goods. The next decade, however, would assure Levi Strauss his place in fashion history.

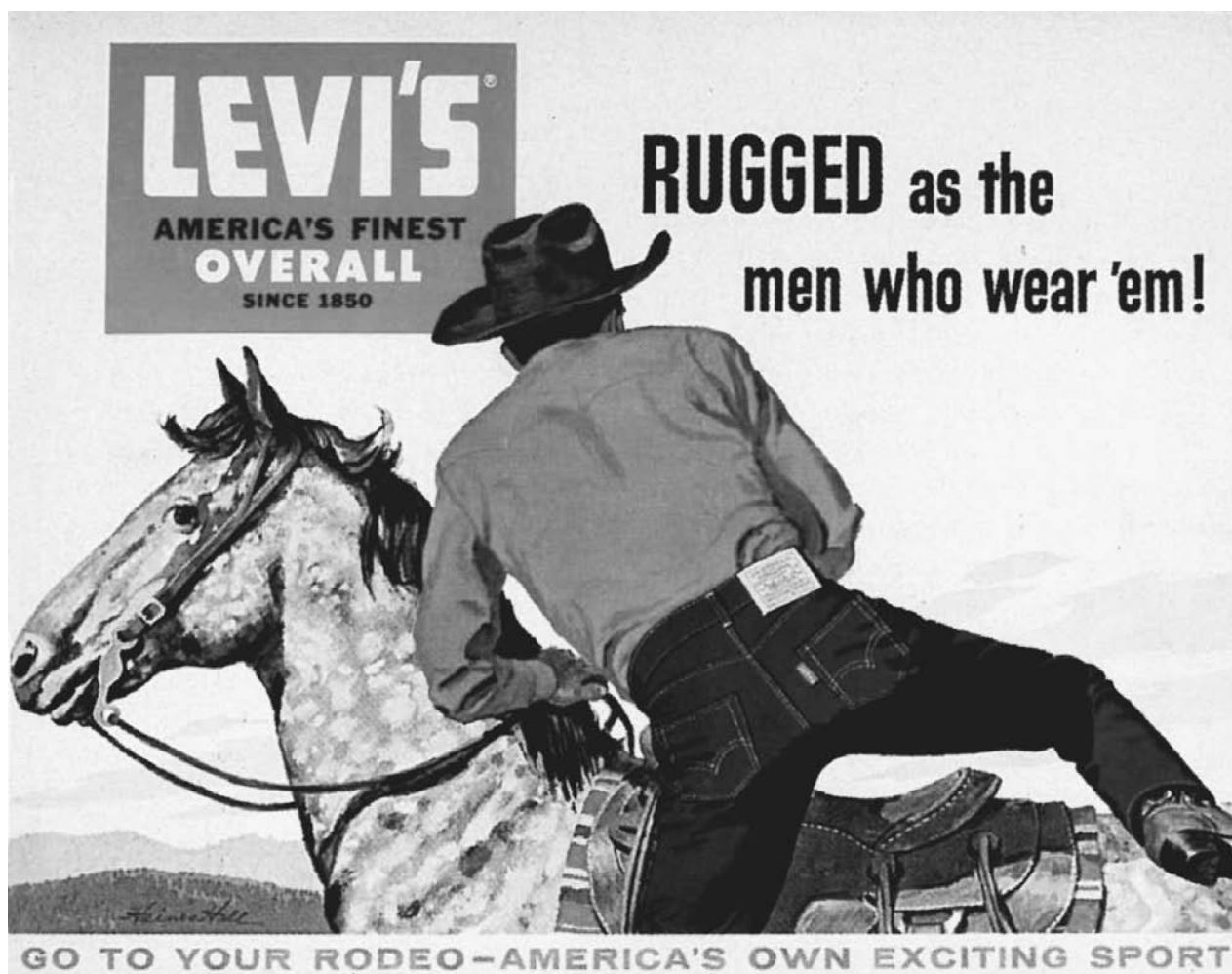

**Levi's advertisement, circa 1950s.** Levi's gained popularity as a fashion item as Western movies romanticized the straightforward and rugged cowboys who wore the jeans. THE ADVERTISING ARCHIVE LTD. REPRODUCED BY PERMISSION.

In 1872, Levi Strauss was contacted by one of his customers, Jacob Davis, a tailor in Reno, Nevada. Davis had discovered a practical and ingenious way to make work pants stronger by adding metal rivets to the weak points at the pocket corners and the base of the fly. Davis's rivets proved successful and his new reinforced work pants became popular among his local clients. Fearful that his idea would be copied, Davis wanted to secure a patent, but did not possess the \$68 necessary to file for a patent. Instead, he turned to Levi Strauss, a successful wholesale goods purveyor from whom he often purchased fabric, and offered to share the patent if Levi Strauss & Co. would underwrite the expense.

Levi Strauss recognized the potential in this endeavor and agreed to share the patent. In 1873, Davis and Strauss received patent #139,121 from the U.S. Patent and Trademark Office for an "Improvement in Fastening Pocket-Openings." The riveted "waist overalls" (as work pants were then known) quickly achieved a reputa-

tion for strength, quality, and durability among working men. For twenty years Levi Strauss & Co. held the patent on riveted waist overalls, thereby curbing competition from other manufacturers. In 1890 the lot number 501 (which it would thereafter retain) was first used to designate the riveted waist overall. The following year, the patent expired and went into the public domain, where riveted waist overalls were quickly copied by other firms. However, the demand for Levi's waist overalls continued to grow, forcing Levi Strauss & Co. to open several manufacturing plants of its own in San Francisco.

By the turn of the century, Levi Strauss was in his early seventies and highly regarded as a successful businessman and philanthropist. He died in September 1902, a lifelong bachelor, leaving the bulk of his \$6 million estate to relatives and to his favorite charities. With his four nephews running the company, Levi Strauss & Co. continued to thrive and became one of the leading companies producing work pants in the 1920s.



The company's market, however, was still restricted to predominantly western states and to the niche of work clothing. In the 1930s and 1940s, Levi Strauss & Co.'s sphere of influence got a boost from Hollywood through western movies. Popular westerns mythologized cowboys and cowboy dress, including the waist overalls. It was during this period that denims became associated with the ideals of honesty, integrity, and rugged American individualism.

After World War II, Americans enjoyed a level of prosperity marked by greater leisure time. Denims, including Levi's, began to lose their connection with manual labor and emerged as appropriate casual dress. Pivotal to the acceptance of denims was their adoption by teenagers, an increasingly vocal and important market group. When the actor James Dean wore blue jeans in the film *Rebel Without a Cause*, denims attained a completely new status as cool fashion. By this time, the term "waist overalls" was no longer used; denims were known as jean pants or simply as "Levi's."

In the 1960s denims continued their evolution as acceptable leisure wear. As a result, denim producers such as Levi Strauss & Co. and Lee (another former working-pant manufacturer) continued to expand. The 1960s was an important decade for fashion—one which witnessed challenges to the traditional haute couture system and the rising popularity of more democratic, street-inspired fashions. Denims emerged as a symbol of individualism and anti-establishment fashion, much to the benefit of Levi Strauss and its competitors. During the height of the hippie era, Levi Strauss & Co. even sponsored a competition to promote the personalized decoration of Levi's jeans.

Founder Levi Strauss could never have foreseen the meteoric rise of Levi Strauss & Co. in subsequent decades. As tastes changed in the 1970s, denims were transformed from leisure wear to high fashion at the hands of designers such as Calvin Klein. Denims now became acceptable dress for all occasions. In the 1970s and the 1980s, Levi Strauss & Co. dominated the market for blue jeans, which became a de facto uniform for youth in America and abroad. Demand for American Levi's in Europe and around the globe was widespread. In Eastern block countries American Levi's jeans even attained the status of black-market cash in the early 1980s.

The importance of the Levi Strauss brand name in the denim market has been enormous. Through clever marketing and hip advertisements, Levi's capitalized on the revival in popularity of the "classic" 501 button-fly jeans in the mid 1980s. By 1990, Levi Strauss & Co. was an international manufacturer with a global market, selling under the brands Levi's, Dockers, and Slates. Only in the late 1990s and early years of the twenty-first century has Levi Strauss & Co. seen a slight reversal of fortune. Changes in taste, from traditional blue to other colors and the revival of retro-1970s flared leg and baggy, hip-hop silhouettes has worked against Levi's classic-cut jeans in

favor of trendy styles marketed by new competitors such as Tommy Hilfiger and Guess. Since the 1990s, Levi Strauss & Co. has been forced to restructure its company to remain competitive. Ironically, Levi's "classic" denims are no longer manufactured in the United States, the production having been entirely shifted to overseas manufacturers with cheaper labor.

Despite competition from the Gap, Tommy Hilfiger, and Guess jeans, Levi Strauss & Co. remains the standard bearer in the denim world. With roots in the settling of America's west, Levi Strauss & Co. has come full circle achieving (and retaining) iconic status as the maker of the quintessential American garment, still popular throughout the world.

See also **Cowboy Clothing; Denim; Jeans; Klein, Calvin.**

#### BIBLIOGRAPHY

Cray, Ed. *Levi's*. Boston: Houghton Mifflin, 1978.

"Custom Fit." *W Magazine* (December 2003): 54–62.

Hambleton, Ronald. *The Branding of America: From Levi Strauss to Chrysler, from Westinghouse to Gillette: The Forgotten Fathers of America's Best Known Brand Names*. Dublin, N.H.: Yankee Books, 1987.

#### Internet Resources

Downey, Lynn. "Invention of Levi's 501 Jeans." About L S & Co. Available from <<http://www.levistrauss.com/about/history/jeans.htm>>.

"Founder Biography." About L S & Co. Available from <<http://www.levistrauss.com/about/history/founder.htm>>.

Lauren D. Whitley

**LIBERTY & CO.** In 1875, Liberty & Co.'s first small shop opened on Regent Street in London's emergent West End. It grew into a showcase for cosmopolitan goods, and the company became synonymous with exotic and avant-garde design. In particular, Liberty garments were associated with the Aesthetic movement.

Arthur Lasenby Liberty (1843–1917), the company's founder, was the son of a small provincial draper. From 1862 his formative business and aesthetic experiences were at Farmer and Rogers' Oriental Warehouse, Regent Street, specializing in fashionable Kashmir shawls and oriental goods.

At Liberty's, Middle Eastern and Asian goods determined the character of the store. Sympathetic to Arts and Crafts ideals, which rejected factory production in favor of hand craft and sought to beautify everyday things, Lasenby Liberty's ambition became the reform of dress and home furnishings along "artistic" lines. As an entrepreneur, he found ways of supplying an expanding market with exotic, handmade goods in a retail environment evoking an oriental *souk* rather than a conventional department store.

### Textiles

Liberty's early catalogs, published from 1881, featured silks remarkable for their variety of color, print, and weight. By the 1880s Liberty's name had become a trademark. "Liberty Art Fabrics" were sensuous and subtly colored, widely admired and imitated. Fashionable aniline dyes were rejected in favor of natural colorings; lack of chemical adulteration, antiquity of design, and irregularity of weave, indicating hand production, were also emphasized.

Initially, dyed and printed silks were imported from India; later, silks were dyed and hand-printed in England, often by Thomas Wardle. Other companies used by Liberty include G. P. and J. Baker; David Barbour; Arthur H. Lee and Sons; Alexander Morton and Co; Turnbull and Stockdale; and Warner and Sons. Leading designers were used anonymously by Liberty. Textile printing was done increasingly by Edmund Littler at Merton, just upstream from Morris and Co.'s workshops. In 1904 Liberty bought the business; until the 1960s, the emphasis was on hand printing with wooden blocks.

Early Liberty textiles were inspired by the Middle East and Asia; by the 1890s, they had a more contemporary look. Although Lasenby Liberty expressed dislike for its more extreme forms, Art Nouveau was dubbed *Stile Liberty* in Italy. "Oriental" designs continued to sell well in the 1920s and 1930s, when small floral patterns also became associated with Liberty fabrics, which then included a huge variety of natural and synthetic materials.

### Cloth and Costume

Liberty fabrics were renowned for their softness. Artists appreciated their draping qualities, and Liberty's early dress designs exploited this tendency to follow the contours of the body. This could be perceived as a challenge to propriety, particularly when used in at-home garments such as the tea gown, pioneered by Liberty and others. Early catalogs are illustrated with vignettes of women in exotic or classical costumes. Some assistants in the shop wore unusual dress; even in the 1930s, shopwalkers wore mediocrally inspired velvet gowns. Liberty's "artistic" styles were imitated and caricatured, notably by the cartoonist George du Maurier.

A Costume Department was established in 1884 to design and make garments suited to the fabrics; eclecticism predominated over fashionable dress. It reflected Lasenby Liberty's determination to control the entire process of design, production, and retailing. The architect E. W. Godwin was consultant designer until his death in 1886. While his earlier designs were notably Japoniste, classical models and the principles of dress reform inspired Godwin's later ideas about dress.

Liberty resisted the dominance of Paris-led styles, although a successful branch was maintained there from 1890 to 1932. Instead, the company pioneered the unstructured cut of Asian clothing as a means of liberating

women from their corsets. *Tokado* was described in the company's 1884 catalog as a "Japanese robe arranged as a tea gown." Other popular garments included the *burnous* cloak, derived from North Africa, and the Greek-inspired tea gown (*Hera*, 1901–1909) was an example of Liberty's attempt to promote classical "Greek" dress well after Godwin's death. As fashion absorbed dress-reform principles, Liberty designs appeared less eccentric. By 1925, a "kimono" style floral-print coat, reminiscent of designs by the French couturier Paul Poiret, appeared highly fashionable. Poiret even used Liberty fabrics in his couture business and, following its demise, designed four collections for Liberty in the 1930s. From the 1880s, Liberty also promoted "Artistic Dress for Children," inspired by the drawings of Kate Greenaway; the "Liberty Smock" was a notable example.

### The Liberty Home

Liberty also developed a reputation for furnishing fabrics, curtains, bedspreads, and upholstery. A furniture department, supported by its own workshops, opened in 1880 under the direction of Leonard F. Wyburd. At first Liberty imported goods from countries seen as "exotic" and pre-industrial, producing handmade, but relatively inexpensive, furniture and artifacts. Lasenby Liberty traveled widely, notably to Japan, to observe their production firsthand. Shrewd business instincts drove him to innovate however, and he had no scruples about modifying designs for the home market, developing hybrid, Anglo-oriental artifacts and other ersatz styles, incorporating Arts and Crafts, "Celtic," "Tudor," Art Nouveau, and oriental elements. He also invested substantially in small companies producing ceramics, metalwork, and jewelry.

During the 1920s and 1930s, Liberty goods changed little, although after both World Wars, traditional, "English" values were favored. In the 1950s and early 1960s, the company redefined itself as contemporary and European, commissioning work from world-class designers. From 1962, Bernard Nevill directed a new era of distinguished textile design; dress reflected the exuberance of the fabrics. When "ethnic" and revivalist styles became fashionable in the late 1960s and 1970s, Liberty acknowledged the exotic and Art Nouveau heritage it had earlier rejected.

The company remained in family ownership until 2000. Subsequently, the store was modernized, and fabrics and oriental goods became less prominent, while greater emphasis was placed on luxury accessories, furnishing, and "idiosyncratic" fashion by international designers.

See also **London Fashion**.

### BIBLIOGRAPHY

Aldburgham, Alison. *Liberty's: A Biography of a Shop*. London: Allen and Unwin, 1975. Commissioned by the company for its centenary.

Ashmore, Sonia. "Liberty's Orient: Taste and Trade in the Decorative Arts in Late Victorian and Edwardian Britain, 1875–1914." Ph.D. diss., The London Institute/The Open University, 2001.

Calloway, Stephen, ed. *The House of Liberty: Masters of Style and Decoration*. London: Thames and Hudson, 1992.

Morris, Barbara. *Liberty Design: 1874–1914*. London: Pyramid Books, 1989.

Okabe, Masayuki et al., eds. *The Liberty Style*. Tokyo: Japan Art and Culture Association, 1999.

Victoria and Albert Museum. *Liberty's 1875–1975*. London: V & A Publications, 1975. Exhibition catalog.

*Sonia Ashmore*

**LINEN** Linen (flax) is considered to be one of the oldest textile fibers. Linen, the commonly used term for flax, a bast fiber, comes from the stem of the flax plant. Flax plants are either raised for their fiber or for the linseed oil harvested from flax seeds. Scientists have traced linen textiles to prehistoric times. Linen cloth was found among the artifacts of Swiss Lake Dwellers dating from 8000 B.C.E. When Tutankhamen's tomb was opened, linen curtains placed in the tomb circa 1250 B.C.E. were still identifiable. Linen was introduced to the Roman Republic by Phoenician traders who originally came from the eastern Mediterranean region. As the Roman Empire spread, so did the use of linen textiles. By the Middle Ages, German and Russian regions were major sources of fiber, while Northern Ireland, Belgium, England, Scotland, and the Netherlands established industries well known for production of linen textiles. It is from this historical development that Irish Linen became a household name and continues in 2004 as a label associated with genuine linen fiber content.

Linen production in North America, and then in Europe, became less important due to an emphasis on producing cotton that began in the eighteenth century. Argentina and Japan joined in production of linen midway into the twentieth century and production in the early twenty-first century extends to New Zealand and China. Russia, Poland, Northern Ireland, Egypt, France, and Belgium are the key producers of linen for the global marketplace. The limitation of requiring hand labor to produce linen fiber, compared to the ongoing mechanization of cotton, also contributed to limited production of linen goods.

### Processing Flax Fiber

Linen is cellulosic and thus has aesthetic, comfort, and performance characteristics reminiscent of cotton and rayon textiles. These include high absorbency, low insulation, a tendency to be cool in hot temperatures. Linen textiles are additionally famous for their ability to "wick," a form of moisture transport known for providing a cooling effect in hot temperatures via drying quickly. Linen



**Irish Linen handkerchiefs.** Ireland was one of a handful of countries producing large amounts of linen by the Middle Ages, and the name Irish Linen remains synonymous with quality.

© GERAY SWEENEY/CORBIS. REPRODUCED BY PERMISSION.

is not subject to linting, the shedding of fibers that can result in bits of fiber lying on the surface of the textile. It is therefore ideal for drying dishes and for appearance retention in apparel. While twice the strength of cotton, linen is highly subject to wrinkling and thus is reputed to produce "prestigious wrinkles." Wrinkling is diminished when fibers are long and fine, and yarns are flexible. Wrinkle-resistant finishes have been applied to many cellulosic fibers as another way to reduce this tendency to wrinkle.

Natural colors for linen fibers include buff and gray. White and pure colors are obtained through bleaching. Highly bleached textiles have lower strength and durability than those with natural color or tonal variations of color resulting when linen is not heavily bleached before dyeing. Dyeing linen is challenging because fibers resist absorbing dyes and fade easily. It has become a tradition that linen textiles are quite often in the buff, tan, and gray colors associated with the look of linen.

Dirt and stains are resisted by flattened smooth surfaces. Linen has high heat resistance, is stronger wet than dry, and withstands cleaning, pressing, and creasing very successfully. Abrasion can break fibers on creases due to low resiliency. Linen textiles are flammable and are subject to damage from mildew, perspiration, bleach, and silverfish.



### Linen in Fashion Across Time

Knitwear has considerable design potential for linen apparel. The flexibility of the knit structure compensates for linen's tendency to wrinkle, yet the textile retains all the comfort factors of natural linen.

Many fabrications appear to be linen. By achieving the visual effect of linen, many textiles are called linen even when fiber content includes little or no linen fiber. For example, textiles labeled linen are often actually either rayon or polyester, or a blend of both fibers. These two fibers that have great propensity to imitate the prestigious look of linen while lowering the cost and sometimes increasing performance in terms of wrinkling and shrinkage without losing the "look of linen." Rayon textiles come a close second with regard to the absorbency, feel on the skin, and similar tendency to wrinkle. Polyester textiles can eliminate the need for ironing. Raw silk and linen suiting textiles can have a quite similar visual aesthetic, yet touching either textile reveals that linen will always have a crisper and dryer feel than silk. Linen supports keeping the body cool, while raw silk is known for keeping the body warm.

Another fiber that has been widely used in imitating linen is ramie. Ramie (also known as China grass due to its origin in China and Asia) has much of the look of linen but is not subject to import quotas, as is linen. Therefore, it is commonplace to find ramie instead of linen as the fiber content for a great many "linen" textiles. Ramie is naturally white so can be dyed a broader range of colors more easily than linen, and thus the products can be stronger since less processing is needed to reach the final product. There is a tendency for these relatively shorter fibers (from 6–8 inches) to produce textiles that have an inherent scratchiness rather than the smoothness of linen. Thus, ramie products tend to be more successful as interior textile products. With the end of fiber quotas, it is expected there will be a moderation in the use of ramie in linen-like products as designers seek creation of high-quality goods.

See also **Ramie**.

#### BIBLIOGRAPHY

- Collier, B., and P. Tortora. *Understanding Textiles*. 6th ed. New York: Macmillan Publishing, 2000.
- Hatch, K. *Textile Science*. Minneapolis: West Publishing, 1993.
- Kadolph, S., and A. Langford. *Textiles*. 9th ed. New York: Prentice-Hall, 2002.

Carol J. Salusso

**LINGERIE** The term "lingerie" is derived from the French *linge*, or linen, and thus makes direct reference to the material from which underwear was traditionally made. By the late nineteenth century, lingerie had become a generic term commonly used to describe under-



**Heidi Klum in Victoria's Secret fashion show.** In the 1990s, California-based Victoria's Secret became one of the most popular and successful lingerie companies. © PETRE BUZOIANU/CORBIS. REPRODUCED BY PERMISSION.

wear that had moved beyond practical function to become a tool of erotic pleasure used for the display of the body during sexual play. The notion that women, other than prostitutes, could use underwear to designate specific occasions as sexual was particularly popularized during the Edwardian era. Under the relatively austere "tailor-made" suit, women were prepared to wear sensual camisoles and petticoats of lace, chiffon, and crepe de chine, offsetting the accusations of "mannishness" directed by the conservative press at the New Woman, a product of the suffragette movement. Lingerie was a symptom of conflicting gender relations at the turn of the century, on the one hand, the suffragette movement promoted a sea change in sexual politics, while lingerie evoked a more traditional brand of femininity, which objectified the female body. Underwear became deliberately branded as either male or female, feminine or masculine, determined by the use of delicate fabrics and applied decoration for women and practical wool and cotton for men. However, as the twentieth century progressed, the increase in the popularity and use of lingerie mirrored women's gradual freedom from the constraints of Victo-

rian morality and notions of what constituted an appropriate femininity as they emerged as more sexually and socially independent beings. Lingerie was also set apart from the rationalist and unashamedly moralistic undergarments advocated by the Victorian Dr. Jaeger, who espoused the use of wool next to the skin for reasons of hygiene and health—lingerie was unashamedly erotic. However, caution was advocated at first: Lingerie should only be used by women within the confines of a happily married life. One female fashion journalist wrote in 1902, “‘Lovely lingerie’ does not belong only to the fast. . . . dainty undergarments are not necessarily [**sic**] a sign of depravity. The most virtuous of us are now allowed to possess pretty undergarments, without being looked upon as suspicious characters” (Steele, p. 194).

At first, handmade lingerie was a sign of social status, afforded only by the very few. Of note were those designed by English couturiere known as Lucile (Lady Duff-Gordon), who fashioned camisoles, peignoirs, and petticoats using lace, chiffon, and crepe de chine—materials that mirrored the feel of idealized flesh, deliberately appealing to the sense of touch, and evoking a new sensuality for the twentieth-century woman. Although artificial fibers such as rayon were marketed in the 1920s as a luxury fabric through the use of the name “artificial silk,” their development led to a democratization of lingerie. The more body-conscious fashions of that decade also led to a new item of lingerie, the teddy, named after its inventor Theodore Baer, who combined a chemise with a short slip or attached panties. The camisole, originally derived from a decorative waist-length garment with an embroidered and pleated front and shoulder straps that were worn over the corset for warmth and modesty, became a staple garment of lingerie, eventually becoming an item of outerwear by the 1970s. Similarly the slip, a standard piece of lingerie from the 1950s and produced by the company La Perla, founded by Ada Masotti, in 1954, was used by a number of fashion designers as outerwear in the 1990s, most notably John Galliano, Dolce & Gabbana.

Sales of lingerie declined in the 1960s as the new silhouette defined by the miniskirt needed a more practical combination of matching polyester bra and panties with tights to replace stockings and suspenders. In the 1970s, however, a lingerie revival was led by the English designer Janet Reger, whose company became one of the most renowned lingerie names of the late twentieth century. Reger was even the object of an essay by the English journalist and cultural commentator Angela Carter, who described her ranges of lingerie as “part of the ‘fantasy courtesan’ syndrome of the sexy exec, a syndrome reflected admirably in the pages of *Cosmopolitan* magazine. Working women regain the femininity they have lost behind the office desk by parading about like *grande horizontale* from early Colette in the privacy of their flats, even if there is nobody there to see” (Carter, p. 97). Carter was prescient in her comments, as with the rise of women entering the executive arena in the 1980s

came an exponential rise in the sales of lingerie and the power suit with a lacy camisole peeping through the jacket became the staple of many a working wardrobe. In the 1990s, a lingerie revival, attracting both male and female consumers, was led by Californian companies Victoria’s Secret and Frederick’s of Hollywood. Victoria’s Secret was estimated in 2000 to be selling six hundred items of lingerie per minute while the simple Egyptian cotton camisole made by the Swiss firm Hanro and worn by Nicole Kidman in Stanley Kubrick’s film *Eyes Wide Shut* (1999) was a major lingerie bestseller. The British company Agent Provocateur, founded by Joseph Corres and Serena Rees in 1994, has successfully integrated the glamour of 1950s underwear with the catwalk, recreating seminal garments like the baby-doll nightie and matching puff panties worn by Carroll Baker in the 1956 film *Baby Doll*. Sourcing vintage undergarments and amalgamating them with new fabrics, such as Lycra, and high-fashion design concepts, they have redefined lingerie as a luxury item with a strong appeal for a young fashion-oriented consumer. Dorothy Parker’s well-known remark, “Brevity is the soul of lingerie,” invokes the appeal of these most personal of undergarments.

See also **Embroidery; Lace; Lucile; Pajamas.**

#### BIBLIOGRAPHY

- Carter, Angela. “The Bridled Sweeties.” In *Nothing Sacred: Selected Writings*. London: Virago, 1982.
- Saint Laurent, Cecil. *The Great Book of Lingerie*. London: Academy Editions, 1986.
- Steele, Valerie. *Fashion and Eroticism: Ideals of Feminine Beauty from the Victorian Era to the Jazz Age*. New York: Oxford University Press, 1985.

Caroline Cox

**LIPSTICK** In many cultures, red lips are an important component of feminine beauty, and this has often prompted women to augment the redness of their lips through artificial means. The modern use of lipstick in Western society has been part of a more general development of makeup for women, one often unstated, and possibly the unconscious goal of which is the emulation of the clear skin, good blood circulation, and sexual fecundity associated with youth and good health.

Lipstick, a cosmetic product used for coloring the lips, and now usually made in the form of a cylindrical stick of waxy material encased in a metal or plastic tube, has a very long history. In ancient Egypt, powdered red ocher in a base of grease or wax was used as a lip coloring. During the time of the Roman empire, henna and carmine, in various preparations, were used for the same purpose. Other ancient lip coloring preparations were made with vermilion or mulberry juice.

Queen Elizabeth I of England made her lips crimson by using a concoction of cochineal blended with gum

Arabic and egg white; her red lips made a striking contrast with her pale powdered face. In the seventeenth century artificially colored lips were denounced as immoral by the Puritan clergy; stained lips were sometimes referred to as “the devil’s candy.” During the eighteenth century, a moderate use of makeup was regarded as normal and attractive for members of the upper classes, but frowned upon for people of more humble status; thus the use of lip color was involved in distinctions of social class. During the nineteenth century, however, in both Europe and America, social commentators generally frowned upon the use of any cosmetics (referred to as “paint”) at all; women who resorted to the conspicuous use of makeup, including lip coloring, invited social criticism. By the end of the century, in turn, many younger women rejected this socially conservative attitude and began to use cosmetics openly. The use of lip coloring came to be one of the beauty secrets of the New Woman.

Until the early twentieth century, lip coloring was often made in the form of a salve, packaged in small jars and applied with a fingertip or small brush. Lipstick as such probably derived from theatrical makeup (“grease-paint”), which was often produced in the form of a waxy crayon or pencil. The term “lipstick” itself dates from the late nineteenth century. Maurice Levy designed the first lipstick in a sliding tube in 1915. Soon thereafter, both Helena Rubinstien and Elizabeth Arden followed his lead and produced lip salve, rouge, and later lipsticks to respond to popular demand.

The influence of movie stars, heavily made up for the screen, may have prompted a shift to stronger colors of makeup, including lipstick, by the 1920s. At that time also, new clothing styles and shorter hairstyles, both of which promoted an image of fashionable youthfulness, led to new styles of makeup and more conspicuous use of lipstick and other cosmetics. By the 1920s also, cosmetic companies relied heavily on advertising to introduce new products, stimulate demand, and promote brand loyalty.

Lipstick came to be associated with other closely related products that were promoted as aids to health and good hygiene. Lip salve and lip balm, designed to protect against sunburn, dryness, and chapping, were introduced around the time of World War II and won widespread consumer approval.

Modern lipsticks typically are made from waxes (beeswax, carnauba wax, palm wax, candelilla wax), oils (olive oil, mineral oil, castor oil, cocoa butter, and others), and chemical dyes. These basic ingredients are supplemented by a range of moisturizers, vitamins, aloe vera, collagen, and other enhancers.

Recent improvements in lipstick have included lip glosses, which give the lips a moist appearance, lipstick with improved adhesion that avoids unsightly lipstick-stained cups and glasses, a wide range of colors keyed to the individual complexions of wearers, and lipsticks that

also contain sunscreen. The palette of fashionable lipstick colors changes from year to year, varying from bright and vivid reds to soft pastels. Lipstick in unusual colors, such as black and dark green, is made for niche markets, such as goths and punks. In the mainstream, the continuing allure of red lips seems to assure that lipstick will be part of the beauty and fashion scene for a long time to come.

See also **Cosmetics, Non-Western; Cosmetics, Western.**

#### BIBLIOGRAPHY

Corson, Richard. *Fashions in Make Up: From Ancient to Modern Times*. London: Peter Owen Limited, 1972.

Ragas, Meg Cohen, and Karen Kozlowski. *Read My Lips: A Cultural History of Lipstick*. San Francisco: Chronicle Books, 1998.

*Elizabeth McLafferty*

**LITTLE BLACK DRESS** At once demure and daring, the little black dress conjures up a host of images and associations. Consistently a symbol of elegance and chic, it is an international fashion icon capable of being interpreted in myriad different styles. Since the late 1920s, some of the world’s most elegant women, including Audrey Hepburn, Marlene Dietrich, Maria Callas, and Edith Piaf, have been photographed wearing a version of the little black dress. Coco Chanel claimed to have “invented”



#### FAMOUS CHARACTERS IN THE LITTLE BLACK DRESS

The little black dress has long been a star of page and screen, its ability to convey meaning a powerful tool. Edith Wharton’s Ellen Olenska in *The Age of Innocence* wore black and shocked New York’s high society when she decided to get a divorce. Majorie Morningstar, the eponymous heroine of Herman Wouk’s novel, wore black, as did Mrs. Danvers of *Rebecca*. Jeanne Moreau was an image of perfection in her Chanel little black dress, chignon, and pearls in Louis Malle’s *The Lovers*. But in *The Bride Wore Black*, Moreau, also in a Chanel little black dress but now a murderess, was anything but perfect. Anouk Aimee wore her signature dark glasses and little black dress in *La Dolce Vita*. Catherine Deneuve’s little black dress was detailed with white in *Belle de jour*, creating an image that was at once pure and corrupt. And perhaps the most famous of all little black dresses was Audrey Hepburn’s Givenchy in *Breakfast at Tiffany’s*.



the little black dress, and that claim has found its way into fashion mythology. But although Chanel greatly influenced the status of the little black dress as a classic fashion item, beginning with her 1926 introduction of a simple black jersey day dress, many other designers were experimenting with the same look at the same time, and black as a fashion color has a long history.

Historically, black has been associated with mourning and asceticism. By the fourteenth century, however, black was being used to create a dramatic effect in one's appearance. In the fifteenth century, Philip the Good, duke of Burgundy, dressed exclusively in black. He was second to none in the luxury of his dress, but in black this magnificence was conveyed with much greater discretion. Black, expensive to produce with natural dyes and thought to convey an air of refinement, became the color of choice for the fifteenth-century Spanish aristocracy, and connoted wealth and social status among the Dutch commercial middle class.

By the eighteenth century black clothing was considered respectable, even dowdy, as it was associated with mourning and the dress of the clergy. Black was revived as the color of elegance, especially for men, by the dandies of the early nineteenth century. The introduction of aniline dyes later in the nineteenth century created a new vogue for bright colors for fashionable women's clothing; black clothing for women signified mourning, or was a badge of middle-class respectability. When fashionable women did wear black it was to make a statement. One of the most memorable, if controversial, examples of this was John Singer Sargent's 1884 portrait of "Madame X," Virginie Gautreau, dressed in a form-fitting black evening gown. Conventional portraiture employed colorful frilly, even demure dress that all but obscured the subject. That Mme. Gautreau, a socialite of the day whose improprieties were hardly secret, appeared in a seductively form-fitting black gown with deep décolletage was quite a departure, underscoring the subject's decision to play by a different set of rules.

In the early 1900s, black "widow's weeds" were still being sold in department stores, but black was beginning to make appearances on other occasions as well. Paul Poiret made vivid colors fashionable between 1908 and 1914. Chanel claimed to be "nauseated" by Poiret's colors and favored instead black, beige, and navy blue. Her 1926 showing of the little black dress was a milestone in the creation of this fashion icon. However, she was hardly alone. The House of Premet had already had a great success with a little black dress. Indeed, the terrible death toll in World War I had resulted in a plethora of fashionable black dresses.

The little black dress was the ideal mix of elements. It was easy, versatile, and practical; it was also chic, elegant, and sophisticated. Capable of embodying many meanings, the little black dress's chameleon-like quality enabled it to evolve with the trends, but never to be beholden to them.



**Actress Audrey Hepburn in black dress.** By the mid-1940s, the versatile little black dress was considered an essential part of every fashion-conscious woman's wardrobe. © SUNSET BOULEVARD/CORBIS SYGMA. REPRODUCED BY PERMISSION.

Of the little black dress, *Vogue* declared in 1944, "Ten out of ten women have one" (MacDonell Smith, 2003, p. 14). Fashion magazines everywhere featured the new phenomenon. By 1948 Christian Dior's groundbreaking New Look was calling for hem- and necklines to drop and skirts to be fuller. The little black dress obliged. As Dior said in 1954, "You can wear black at any time. You can wear black at any age. You may wear it on almost any occasion. A little black frock is essential to a woman's wardrobe" (MacDonell Smith, 2003, p. 14).

The little black dress's versatility ensured its immortality. Parisian Left Bank intellectuals wore it for its associations with creativity and rebellion. Paired with black tights and black eyeliner, it was the uniform of the beatnik generation. Audrey Hepburn wore black in *Funny Face*, and a little black dress by Givenchy in *Breakfast at Tiffany's*.

The 1960s marked a low point in the life of the little black dress. Not only did one of its masters, Cristóbal Balenciaga, retire in 1968, but it was an era focused on a

youthful sense of color and fun rather than sophistication and elegance. But a decade later, a new generation of designers began to make it once again the uniform of the modern woman. From Claude Montana's versions in leather to Azzedine Alaïa's in stretch fabric, the little black dress took on a more aggressive edge during the late 1970s and 1980s. Showcased at the groundbreaking New York store Charivari, the status of the little black dress was underscored by Helmut Newton, the German-born, Australian photographer, known for his blatantly provocative erotic, sometimes violent images of women. The evolution continued and by the early 1980s a new breed of Japanese designers led by Rei Kawakubo and Yohji Yamamoto reinterpreted the little black dress according to new somber, intellectual criteria.

At the turn of the twenty-first century, the little black dress remains a mainstay of the clothing industry and a must in the wardrobe of every woman. At once impervious to and accommodating of the vicissitudes of fashion, the little black dress has become a lens through which to view the evolution of fashion and dress, since at least the late 1920's.

See also **Balenciaga, Cristóbal; Chanel, Gabrielle (Coco).**

#### BIBLIOGRAPHY

- Hollander, Anne. *Seeing Through Clothes*. New York: Viking Press, 1978.
- Ludot, Didier. *The Little Black Dress: Vintage Treasure*. New York: Assouline Publishing, 2001.
- MacDonell Smith, Nancy. *The Classic Ten: The True Story of the Little Black Dress and Nine Other Fashion Favorites*. New York: Penguin Books, 2003.
- Mendes, Valerie. *Black in Fashion*. London: Victoria and Albert Museum Publications, 1999.

*Liz Gessner*

**LOGOS** The logo (logotype) is the emblem or device used to identify a particular company or organization. The design of a logo may be based around the name or initials of a company using a distinctive letter form, such as Coca-Cola (first used in 1887). It may also be a visual symbol of abstract or figurative design, such as the Nike swoosh (designed 1971). In order to function effectively a logo must be easily recognized in a variety of forms—on products, packaging, and advertising.

The logo is the modern equivalent of the maker's stamp; the hallmark or trademark that indicates the authenticity of a product. Logos, like monograms, heraldic devices, flags, and crests, are forms of graphical devices that have been used to indicate the origin, ownership, and status of property and people.

Law protects modern logos, so that the form, color, shape, and graphical detail of any mark cannot be copied or closely imitated without legal redress. This legisla-

tion was put into place in the mid-nineteenth century in Europe and America, and is now effective across national borders.

The logo is central to any company's concept of its brand. As the graphic designer Milton Glaser once said, "The logo is the point of entry to the brand" and is used to encapsulate all that a brand may stand for. A logo with a high recognition factor can be a major financial asset to any business, and therefore it sits at the heart of any corporate identity policy. A manufacturer's product range may change from season to season, but successful logos are rarely tampered with and, when design changes are made, they are usually subtle rather than radical. Logos also need to be adaptable to a variety of uses. The interlocking CC logo of Chanel, like many logos used by the garment industry, work well as both a repeat pattern on fabric and as an embossed button on a coat or jacket. The "Medusa head" logo used by Versace was adapted from a classical architectural motif. It can be used in print or relief, and appears on stationery, packaging, buttons, cosmetics containers, and tableware.

The use of the logo as a decorative element was traditionally the preserve of the luxury goods sector (rather than the clothing industry). Leather goods (luggage and saddlery) companies have exploited the familiarity of their logos and signature patterns as they compete in the high-fashion market. The French luggage company Louis Vuitton (founded 1854) first used its monogram in a repeat-patterned canvas in 1896, and the monogram fabric has been a staple of its collections ever since. The monogram pattern has been reinterpreted by a succession of designers from the mid-1990s, including Marc Jacobs and Stephen Sprouse. Gucci's monogrammed fabric, using the GG logo adopted in the 1960s, appeared for many years on handbags and as linings before being used for clothing.

One key factor in the development of fashion branding has been the shift of the "signature" or logo from the inside to the outside of the garment. Conventionally, the designer or manufacturer's label would be sewn inside a garment, originally to guard against the illegal copying of fashion house models. In the field of sportswear, logos began to be more prominent in the 1940s, when the brand named after the tennis star Fred Perry borrowed the idea of the team or club crest, displayed on the breast of shirts and sweaters. In the 1970s, when sportswear was worn increasingly off pitch, court, or course as leisurewear, brands such as Lacoste and Fred Perry used their logos to brand generic garments like the polo shirt. This first wave of fashion sports brands was eclipsed by the phenomenal rise of global sports corporations such as Nike in the 1980s and 1990s.

The "designer decade" of the 1980s introduced many more designer logos to the mass market, where they became adopted as part of street culture. Logos associated with status and expense, such as BMW and Mercedes car mascots in the shape of corporate logos, were worn as jew-

elry by American rap artists. Heavily branded sportswear by Nike and Tommy Hilfiger (where the logos became increasingly prominent) was worn with a brash, competitive attitude and an emphasis on “box-fresh” products. Between 1995 and 2000, several high-fashion brands including Gucci, Fendi, Dior, and Louis Vuitton produced collections almost entirely focused on the repeat use of the logo (dubbed “logomania” by the style press).

Reaction to this visibly over-branded culture has been strong. One economic and legal side effect has been the flourishing of a counterfeit trade in clothes and accessories where fake logos are applied to unlicensed and inferior goods. The other effect is cultural and political. Global brands have come under attack by the so-called “No Logo” generation (named after Naomi Klein’s 1999 book of that title), who reject overtly branded goods as symbols of late capitalist economic exploitation and social inequality.

See also **Brands and Labels**.

#### BIBLIOGRAPHY

Clifton, Rita, and John Simmons, eds. *Brands and Branding*. Princeton, N.J.: Bloomberg Press, 2004.

*Jane Pavitt*

**LONDON FASHION** In the twenty-first century London ranks highly amongst the world’s cities as a distinctive fashion center. Its characteristic products and sense of style compete with and complement the fashion values of other global fashion capitals including Paris, New York, Milan, and Tokyo. In the popular imagination, which is fed by the stereotyping tendencies of fashion journalism, London has become most associated with the traditional handcrafts of tailoring, shirtmaking, hat-making, and shoemaking that underpin the image of the English gentleman, a vibrant subcultural club and street scene, and the nurturing of eccentric and innovative design talent in its famous art schools. These are largely phenomena that blossomed during the twentieth century, but London’s fashion history is as old as the city itself and closely related to its economic, social, and cultural development over time.

With its thriving docks and strong mercantile economy, London operated as a natural hub for trade and cultural exchange in the late medieval period, building on a heritage that stretched back to its status as an important port on the western fringes of the Roman Empire. By the fifteenth century, it was already one of the largest cities in the world, though it could not compete with smaller European centers such as Paris, Florence, and Rome as a focus for the production and display of fashionable commodities. London operated more as a transit point in an international fashion system, exporting primary or unfinished products like wool and metal and importing

luxuries such as fur and embroideries. But in a national context, the city began to exert a formidable political and cultural pressure over the rest of the country as parliament, law courts, and the crown established permanent bases there. This process drew the rich and influential into London and helped to ensure that fashionable trends originated in its streets, markets, and great houses. The palaces of Henry VIII, Elizabeth I, and Charles I at Hampton Court, Greenwich, and Whitehall thus operated as forcing houses for a very English sense of sartorial style, which nevertheless still relied largely on the pattern books, fabrics, and craftsmanship of Spain, France, and Italy for its luxurious impact.

By the early eighteenth century, the political stability afforded by the accession of the Hanoverian line of monarchs and a prosperous professional class, together with the increased income that attended London’s rise as the capital of a widening network of colonies, meant that the city entered a new phase of development during which its growing confidence and urbane sophistication produced the distinctive sartorial identity that would influence world trends for the next three centuries. After the Great Fire of 1666, London’s developers and architects had shifted their attention westward and the arising geography of graceful squares and parks encouraged the aristocracy to base their domestic and business affairs in the West End during those periods of the year (later known as the Season) when Parliament was sitting or the royal family was in residence. The flurry of social activity that followed, with its balls, theater visits, and court presentations, offered great incentives to entrepreneurs in the clothing trades, and it was on this basis, from the 1740s on, that the craftsmen of Savile Row, Jermyn Street, and St. James’s established themselves as producers of a home-grown masculine style of dressing, replete with the genteel codes and sporting influences that have bracketed the idea of London with the identity of the dandy. The methods of tailoring developed in Savile Row in the eighteenth century also went on to inform the design of women’s wear in the capital, producing the severe “tailor-mades” of the late nineteenth century and the artfully restrained creations of Norman Hartnell, Hardy Amies, and Victor Stiebel in the mid-twentieth century.

Through the nineteenth century the range and organization of the clothing industries in London expanded considerably, augmented by successive waves of immigration. As the West End became increasingly associated with the consumption of high quality, locally produced bespoke goods, so the East End or working-class districts of Aldgate and Bethnal Green played host to other, less prestigious forms of manufacturing. In the eighteenth and early nineteenth centuries, the French Huguenot community had woven high-quality figured silks for gowns, waistcoats, and ribbons in the upper floors of their tall Spitalfields houses, but by the 1870s, when the fashion for brocades had passed, the sewing of shirts and ready-made suits provided one of the few opportunities



for employment in an area bedeviled by poverty and overcrowding. Even then, the infamous practice of sweating ensured that clothing production was a profession of poor pay and low esteem, associated with the exploited labor of women and Jews.

Some aspects of Victorian London's fashion scene maintained a positive gloss. In line with the city's entrepreneurial spirit, the capital witnessed several pioneering inventions such as William Perkin's discovery of synthetic (aniline) dyes in the late 1850s or Thomas Burberry's experiments with waterproofing later in the century. Perhaps the most lasting innovations to come out of London in the period were in the realm of fashion retailing. By the 1830s the West End had been transformed by the architectural renewal set in place by the Prince Regent and John Nash. The new arcades leading off of Piccadilly and the majestic sweep of Regent Street offered a fresh conception of shopping as a modish leisure activity for the middle and upper classes, where emphasis was placed on spectacular display, comfort, and escapism. Unsurprisingly the first great couturier Charles Worth learned his trade in a Regent Street emporium, and two decades later in the 1870s and 1880s Arthur Liberty perfected the selling of a lifestyle nearby, in a store that provided all the exotic accoutrements for the aesthetic movement. Napoleon's dismissive take on the English as a nation of shopkeepers would find further resonance in the development of the great London department stores such as Harrods, Selfridges, and Harvey Nichols from the Edwardian period on, and the emergence of the "happening" fashion boutique in Chelsea and West Soho in the 1950s and 1960s.

These London traits of tradition, innovation, and a certain sense of theatricality continued to inform the development of fashionable style in the city in the twentieth century. In the late 1940s and 1950s young men from chic Mayfair and working-class South and East London, with seemingly little else in common than a passionate interest in style as a means of subverting the stultifying status quo, resurrected Edwardian notions of elegance in a shocking manner of dressing that soon became associated with the "Teddy Boy" craze. Their velvet-trimmed draped jackets, drainpipe trousers, and extravagantly combed hairstyles presaged a succession of teenage poses whose influence was felt worldwide. The Mods of 1960s Carnaby Street and the Punks of 1970s King's Road all earned London a certain notoriety as the breeding ground for revolutionary acts of sartorial rebellion.

Various London designers have found their inspiration in this street-level creativity. In the 1960s Mary Quant, Barbara Hulanicki (of Biba), and Ossie Clarke were closely associated with the phenomenon of "Swinging London," famously promoted to America by *Time* magazine in 1966; while in the 1970s Zandra Rhodes and Vivienne Westwood offered a more astringent and eccentric take on contemporary mores. By the 1980s and 1990s a generation brought up in the hedo-

nistic, post-punk environment of neo-romanticism and the commercial club scene, seemed more adept at selling their London-honed individuality abroad. Central Saint Martins-trained John Galiano, Stella McCartney, and Alexander McQueen, and the Royal College protégé Julien McDonald have thus famously risen to supplant local talent at the creative helms of the great Parisian fashion houses. But behind the famous names, the studios and warehouses of London continue to support an active and influential local economy of young independent designers, stylists, photographers, publishers, and journalists (London has nurtured a wide-range of edgy fashion magazines including *The Face*, *i-D*, *Sleaze Nation*, and *Dazed and Confused*). Though there has been little concrete state support for the growth of a British fashion industry, the sheer size, diversity, and chaotic energy of the British capital still seems to foster a productive and adventurous sartorial spirit in the early twenty-first century.

See also **Amies, Hardy; Biba; Clark, Ossie; Europe and America: History of Dress (400–1900 C.E.); Galiano, John; Hartnell, Norman; McQueen, Alexander; Paris Fashion; Rhodes, Zandra; Royal and Aristocratic Dress; Westwood, Vivienne.**

#### BIBLIOGRAPHY

- Breward, Christopher. *Fashioning London: Clothing and the Modern Metropolis*. Oxford: Berg, 2004.
- Breward, Christopher, Edwina Ehrman, and Caroline Evans. *The London Look*. New Haven, Conn., and London: Yale University Press, 2004.
- Tucker, Andrew. *The London Fashion Book*. London: Thames and Hudson, Inc., 1998.

*Christopher Breward*

**LOOM** Although the process of weaving has been modified and adapted to every technological advancement known to humanity, including that of computers, when one watches a contemporary weaver working at a loom in the early 2000s, what is being observed is essentially a process, and equipment, that goes back thousands of years. The loom was invented as a means to hold one set of elements, the warp (yarns extended lengthwise on the loom), under tension so that the second set of elements, the weft (yarns running crosswise), could be inserted and interlaced with the warp, to form cloth. The loom that most contemporary weavers use is called a floor loom (or a treadle loom, a shaft loom, or a harness loom). There are numerous companies making these looms in the early twenty-first century, each with its own modifications, but the essentials of the shaft looms are the same.

#### Elements of a Shaft Loom

The essential parts of a shaft loom are illustrated in the given diagram. The loom has a frame with both a front

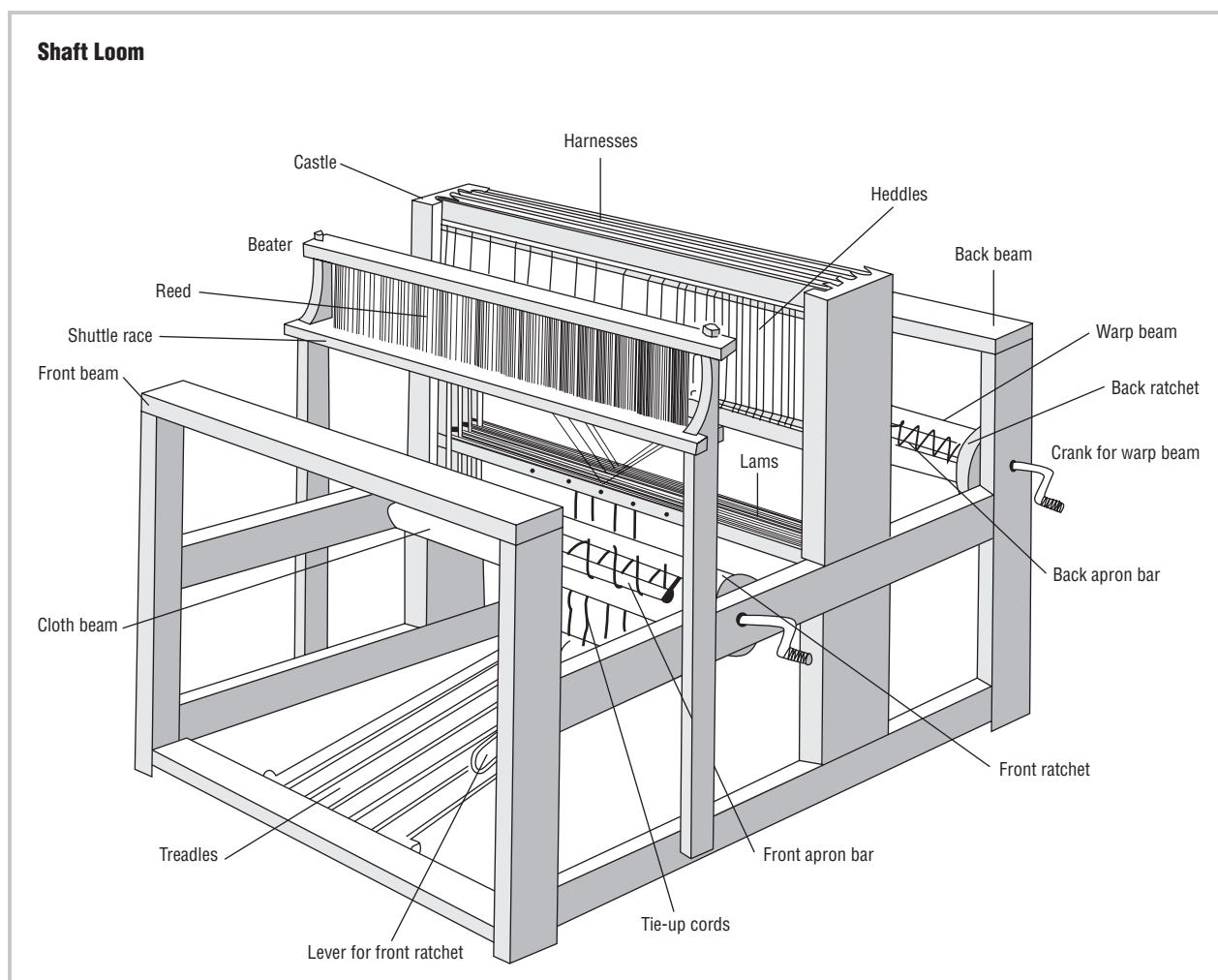

**Shaft Loom.** Also known as a floor loom, the shaft loom is the loom used most often by contemporary weavers.

beam and a back beam. Below the back beam lie one or two warp beams, which hold the warp or warps threads. Each warp beam will have a crank attached to it that is used to turn the beam as the warp is wound on to it. Below the front beam is the cloth beam, which holds the finished cloth as it is woven. The warp is tensioned between the back and cloth beams; the tensioning of these threads is one of the essential reasons for having a loom.

The castle is in the middle of the loom; it can be high or low, depending on the manufacturer, and the shafts (sometimes called harnesses by weavers in the United States) are seated within it. The shafts can be suspended from chains or ropes attached to levers or pulleys, or they may be riding in slots at the side of the castle.

Floor looms are generally built with anywhere from 2 to 24 shafts, though the majority of looms are 4-, or 8-, or 16-shaft looms. Shafts are movable frames that hold heddles. Heddles have eyes (holes) in their center through

which individual warp ends are threaded. In the space between the shafts and the front beam, a loom has a beater, which may be suspended from a high castle or pivoting from the bottom of the loom. The beater has a furrow in its frame in which a reed is placed. Reeds are flat metal or steel combs, with evenly spaced teeth. The spaces of a reed are called dents, and these are manufactured with different specifications. A weaver will usually have a number of different reeds (perhaps one with 8 dents per inch; one with 12 dents per inch; maybe one with 20 dents per inch). Depending on the sett (the density) of their warp, the weaver will insert the appropriate reed into the beater. When the beater is brought forward during weaving, the reed passes smoothly between the warp ends that are threaded in it, and then pushes the weft into the web of the cloth. More than one warp end can pass through a dent of the reed, as long as they are adjacent ends. The front of the beater usually extends a bit under the threads, and is called the shuttle race. When the shuttle (the device that

holds a bobbin wound with the weft yarn) is thrown from edge to edge, it slides smoothly along the shuttle race.

Floor looms have treadles (pedals) that are attached to the shafts, so when a treadle is depressed the shaft will raise or lower. Lamms are the horizontal levers that reside between the treadle and the shaft and they help with the mechanics of the lifting of the shafts. Looms are usually equipped with the same number of treadles as shafts, plus two; but some four-harness looms have only four pedals. Since a weaver needs to change which shafts are tied to a pedal fairly often, the ease of changing the connection (the tie-up) is very important. Some manufacturers use string devices to make the tie-up; others use metal hooks.

At the front side of the loom, usually the right side, is another pedal, called the brake pedal. When the weaver depresses the brake pedal, it releases the ratchet that is holding the cloth beam tight, and allows the warp to be moved forward. There is a lever attached to the front ratchet, which is attached to the cloth beam, and the weaver can move this ratchet to roll the cloth forward onto the cloth beam. A weaver needs the ratchet on the warp beam to fall back into place as soon as the brake pedal is released, so she can use the front ratchet and tension the warp so weaving can proceed.

Most looms also have cloth aprons attached to both the warp beam and cloth beam. They act as extensions for the warp so there won't be too much yarn wastage at the beginning and end of the weaving. Strings can be used instead of cloth aprons.

When a loom is "dressed" with a warp, the warp is wound evenly on the warp beam, passes over the back beam, through the eyes of the heddles on the shafts, through the dents of the reed in the beater, over the front beam, and then is tied to the cloth beam. Each individual warp end passes through a different heddle, and its path should be straight from back to front. The reed not only acts as a comb to beat the weft into the cloth, it also acts to keep the warp threads in order and spaced out to their required width.

### Jack-type looms

Card weaving, also known as tablet weaving, is a very ancient process. Here square cards have holes near each corner, and a warp end is threaded through each hole. When the weaver puts tension on the threaded warp, a shed forms between the ends on the two top holes and those in the bottom holes. After a weft is inserted, the cards are turned, either forward or backward, and a new shed is created. Amazingly intricate narrow bands have been woven with tablets (sometimes they are triangular or hexagonal), including Buddhist prayer bands that were woven in Burma until the early twentieth century. Card weaving can also be done using an inkle loom (band loom, a small loom that allows for a tubular warp that can be moved as weaving proceeds), or just tensioning the warp between two stationary posts or C-clamps.

### Horizontal ground-loom

A dobby loom is a modified shaft loom, which uses a sequence of pegged bars to make the lifts for weaving. When the textile industry embraced the industrial revolution, electrical dobby looms and cam looms wove most of the simple fabric. These looms have now given way to computerized versions of them that can weave more than 750 picks per minute. Many handweavers also use computerized dobby looms for their weaving.

See also **Weave, Jacquard; Weaving; Weaving, Machinery.**

### BIBLIOGRAPHY

- Barber, E. J. W. *Prehistoric Textiles*. Princeton, N.J.: Princeton University Press, 1991.
- Broudy, Eric. *The Book of Looms*. Hanover, N.H.: Brown University Press, 1979.
- Chandler, Deborah. *Learning to Weave*. Loveland, Colo.: Interweave Press, Inc., 1984.
- Fannin, Allen A. *Handloom Weaving Technology*. New York: Van Nostrand Reinhold Company, 1979.
- Hecht, Ann. *The Art of the Loom*. New York: Rizzoli, 1989.
- Roth, H. Ling. *Studies in Primitive Looms*. McMinnville, Ore.: Robin and Russ Handweavers, 1981. Reprint of original edition published in 1918.
- Ziek de Rodriguez, Judith, and Nona M. Ziek. *Weaving on a Backstrap Loom*. New York: Hawthorn Books, 1978.

*Bhakti Ziek*

**LUCILE** Although many of Lady Duff-Gordon's claims to originality and innovation are now discredited, her high-end dressmaking firm Lucile remains a potent example of early British couture. Although at the forefront of designing and merchandising clothes for society women at the turn of the twentieth century, these skills were eclipsed by her talent for literary biography demonstrated by the entertaining autobiography *Discretions and Indiscretions* (1932) that was intended to cement her reputation with a light, literary style of prose.

Divorced from an alcoholic husband and with little formal education, Lady Duff-Gordon persuaded her mother in 1889 to save her reputation by financially backing her as a dressmaker, capitalizing on her only practical skill of sewing. Her first design was based on a tea gown, inspired by a dress worn by an actress on stage. It became her calling card for society ladies and was worn by the Hon. Mrs Arthur Brand on the occasion of her staying with a society hostess.

The tea gown originated as a garment worn by society women when in the country, after they had de-robed from their shooting tweeds and before donning evening dress for dinner. This practice is considered to have followed on from them being solely worn for the purpose of taking tea. Set between function and formality the loose and un-corseted style of the garment implied, if not



a state of undress, then at least a private and introspective state on the part of the wearer. Duff-Gordon seized on the risqué potential of the tea gown as a way of challenging late Victorian London's views on modesty and morality in women's dress, while championing her own cause for notoriety. This led her to be accused of peddling the cult of immoral dressing (Etherington-Smith 1986, p. 73).

The association of the tea gown with refreshment and sociability between women became actively embedded in the business, most notably at Maison Lucile, her Hanover Square shop at no. 17 opened in 1897 (no. 23 opened in 1901).

Duff-Gordon's belief that "nobody had thought of developing the social side of choosing clothes, of serving tea and imitating the setting of a drawing-room" informed her idea of a commercial space for the selling of clothing appearing as a space of leisure and, to some degree, domesticity. However, it was her skill in innovative sales techniques that helped to establish a glamorous cult of personality for both the designer and her committed clients.

Lucile's business was unusual in that it also was well known for designing theatrical dress for the stage. Many of the features of dress design that Lucile became renowned for, such as the delicate layering of fabrics, fusions of color, and use of filigree and trim, were very much learned from the traditions of theatrical dress design that were engineered to catch the floodlights and project the performer.

Yet it was in her efforts to create a theatrical setting in her own salon for the presentation of her latest designs for the fashionable woman that Duff-Gordon excelled. From a small stage hung with olive-colored chiffon curtains, she presented collections on models that she personally trained in deportment, each one bearing a dress with a literary title rather than a number. Duff-Gordon termed them "Gowns of Emotion," also referred to at the time as personality dresses. This oddity began in her wish to promote the idea that the clothes she made in her early career were individual to each client. As a working practice, this went against the model of practice for a couturier established by Worth, who always decided the blueprint of what all fashionable woman should wear. Duff-Gordon's approach suggested that the inspiration of what could be termed fashionable was drawn from the

innate quality of each of her clients individually; a dress that could suit their personality rather than their needs.

Lucile's Gowns of Emotions were given titles such as *The Captain's Whiskers*, *The Sighing Sound of Lips Unsatisfied*, and *Twilight and Memories*. In associating the appearance of a dress with an inner state of mind, the disassociation of dress from social hierarchy and towards signifying a psychological state began.

What is also notable about Lucile's titles is their similarity to the themes of love found in the salacious novels written by Duff-Gordon's sister, Elinor Glyn, who also wore her sister's designs. Many of Glyn's fashionable works featured well-dressed women with descriptions that faithfully aped the latest designs of Maison Lucile. Duff-Gordon's last epic was not to be literary invention. In 1912 she survived the inaugural trip of the *Titanic*. For her husband, who also survived after joining her in a rescue boat intended for women and children only, it led to the end of his reputation. For Duff-Gordon it was the final chapter in a sensationalized career. To distance herself from the tragedy of the *Titanic*, Lady Duff-Gordon moved her career to New York where her models came to the attention of Florenz Ziegfeld in 1916. Ziegfeld persuaded Duff-Gordon to let her models wear her creations in his current Follies. She designed the costumes until 1920.

See also **Haute Couture**; **Tea Gown**; **Theatrical Costume**.

#### BIBLIOGRAPHY

- Beaton, Cecil. *The Glass of Fashion*. London: Weidenfeld and Nicolson, 1954.
- Duff-Gordon, Lady. *Discretions and Indiscretions*. London: Jarrolds, 1932.
- Etherington-Smith, Meredith, and Jeremy Pilcher. *The It Girls: Lucy, Lady Duff Gordon, the Couturière 'Lucile' and Elinor Glyn, Romantic Novelist*. London: Hamilton, 1986.
- Glyn, Elinor. *Three Weeks*. London: Duckworth and Company, 1907.

Alistair O'Neill

**LYCRA.** See **Elastomers**.

**LYOCELL.** See **Rayon**.



**MACARONI DRESS** “Macaroni” was a topical term connoting ultra-fashionable dressing in England circa 1760–1780. First use of the term appears within David Garrick’s play *The Male-Coquette* (1757) that includes the foppish character the Marchese di Macaroni. Although used occasionally to refer to women noted for their conspicuous gambling—described, like fashion, as a form of ephemeral expenditure—the term generally referred to the styling of men. The famous observer of manners Horace Walpole makes numerous reference to these figures. In the first relevant letter, dated February 1764, Walpole discussed gambling losses amongst the sons of foreign aristocrats at the “Maccaroni [*sic*] club, which is composed of all the traveled young men who wear long curls and spying-glasses” (Lewis 1937, p. 306). The “Macaroni Club,” was probably the Whig venue Almack’s in St. James’s, the court end of London.

Macaroni dress was not restricted to members of the aristocracy and gentry, but included men of the artisan and servant classes who wore examples or cheaper versions of this visually lavish clothing with a distinctive cut. To wear macaroni dress was to wear the contemporary continental court fashion of the male suit, or *habit à la française*, which consisted of a tight-sleeved coat with short skirts, waistcoat, and knee breeches. At a time when English dress generally consisted of more sober cuts and the use of monochrome broadcloth, macaronis emphasized pastel color, pattern, and textile ornamentation which included brocaded and embroidered silks and velvets, some encrusted with chenille threads and metallic sequins. Fashionable men in the late 1760s and 1770s replaced the small scratch-wig of the older generation with elaborate hairstyles that matched the towering heights of the contemporary female coiffure. For men, a tall toupée rising in front and a club of hair behind required extensive dressing with pomade and white powder. This wig was garnished with a large black satin wig-bag trimmed with bows. The use of a pigtail and wig-bag was viewed as a Francophile affectation; so much so that the visual shorthand for Frenchmen in caricature imagery was this device.

Macaroni men deployed a number of accessories that characterized court society. These included the hanger sword, which was traditionally the preserve of the nobility, and which in England was fading from general use.

Other Macaroni features include red-heeled and slipper-like leather shoes with decorative buckles of diamond, paste, or polished steel; a tiny *nivernais* or *nivernois* hat named after the French ambassador resident in London; large floral corsages or nosegays; chateleines or hanging watches, and seals suspended around the waist; decorative neoclassical metal snuffboxes; and eyeglasses feature in descriptions of macaronies. These objects contributed to an emphasizing of courtly artifice in posture, gesture, and speech further underlined by the use of cosmetics such as face-whiteners and rouge. According to contemporary reports, there was even a highly mannered macaroni accent and idiom, captured in popular ditties of the period. Colors particularly associated with the macaroni include those used in the contemporaneous interior design of Robert Adam: pea green, pink, and deep orange. Striped or spotted fabrics on stockings, waistcoats, and breeches appear to have been popular fashions, sometimes worn in contrasting arrangements.

### Macaroni Motives

Macaroni identity was not a peripheral incident in eighteenth-century culture but a lively topic of debate in the periodical press. Motives for retaining elaborate dress requisite at court but not necessary in the streets of commercial London was various, inflected by the class interests and personal motivations of the wearers. Macaroni status was attributed to such famous figures as the Whig politician Charles James Fox (1749–1806), “the Original Macaroni;” the botanist and South Sea explorer Sir Joseph Banks (1743–1820), the “Fly Catching Macaroni;” the renowned miniature painter Richard Cosway (1742–1821); the famed landscape garden-designer Humphrey Repton (1752–1818); the St. Martin’s Lane luxury upholsterer John Cobb; Julius “Soubise,” the freed slave of the duchess of Queensbury, the “Mungo Macaroni;” and the Reverend William Dodd (1729–1777), the extravagantly-dressed Chaplain to George III. Aristocratic Whig adherents emphasized a version of ultra-fashionable court-dress in order to assert their preeminent wealth and privilege in the face of Tories, the English court, and its more modest Hanoverian monarchy. French and Italian goods and manners had added appeal in that travel to the Continent had not been possible and the importation of French textiles had been banned during the Seven Years War



### HISTORICAL DEFINITION

"Macaroni [sic], An Italian paste made of flour and eggs; also, a fop; which name arose from a club, called the Macaroni [sic] Club, instituted by some of the most dressy travelled gentlemen about town, who led the fashions..."

Pierce Egan. *Grose's Classical Dictionary of the Vulgar Tongue*. Revised and corrected, with the addition of numerous slang phrases, collected from tried authorities. London, for the Editor, 1823 [revised ed. of work published 1785], n.p.

(1756–1763). Alleged macaroni status was used to attack the professional credentials of Joseph Banks within the scientific community; Cosway was similarly ridiculed as an absurd-looking parvenu. Dodd, the "Macaroni Parson," in becoming the subject of a forgery trial resulting in his execution, further highlighted the potency of the macaroni label.

### Historiography

Macaroni dress was lampooned as excessive and bizarre in numerous caricature prints, plays, and satirical texts. The macaronies form the largest subset within the English graphical social satires produced in abundance from the early 1770s. The catalogers of the British Museum caricature collection, Frederic George Stephens in 1883 and Dorothy George in 1935, published a wealth of primary material relating to macaronis that has formed the basis of all further studies. Aileen Ribeiro wrote the first article devoted to them in 1978, and has included them in subsequent studies of eighteenth-century costume, where they are discussed as an amusing episode in the sartorial folly of young men. In 1985 they formed the subject of an article by Valerie Steele that broadened awareness of their social and political influence and helped lift them from the



"Such a figure, essenced and perfumed, with a bunch of lace sticking out under its chin, puzzles the common passenger to determine the thing's sex; and many a time an honest labouring porter has said, by your leave, madam, without intending to give offence."

"Character of a Macaroni." *The Town and Country Magazine* vol. IV, May 1772, p. 243

taint of triviality. Diana Donald's study of caricature indicates that a reading of the macaroni type provides important insights into eighteenth-century English society. She highlights their role in defining the English character as sane and measured in contrast to the reign of folly experienced across the Channel. Represented in a wide range of verbal and visual sources, from the press to the theater, the macaronis provided the perfect frame for critique regarding consumption and emulation, as they suggested wild expenditure, the spread of fashionability, and even the cult of gambling in late-eighteenth-century English society.

The commonly held explanation for the title "macaroni," that it was derived from a fondness for that Italian dish, may be supplemented in that "macaronic" refers also to a type of mixed language poetry known for its wit, a hallmark of the macaroni stereotype. "Macaroni" thus also suggested the world of the medieval carnival, burlesque, carousing, and excessive food. The macaroni was regularly connected with a slavish and shallow love of things continental and Catholic. The amused suspicion of the English toward these supposedly uncritical followers of fashion is linked to a hostility toward fashionable dress that had colored British life since at least the seventeenth century. This censure had generally been more strongly directed at women, and the macaroni episode shifted much of this attention toward a redefinition of effeminate men. In occasional prints, plays, and satires the macaroni was cast as an indeterminate figure who did not fit normative stereotypes of gender and sexuality. Sometimes the macaroni stereotype took on sodomitical suggestion. Fictional descriptions of "Lord Dimple," "Sir William Whiffle," and "Marjorie Pattypan" deployed the notion of a neutral or unnatural gender in which "inappropriate" feminine attributes were grafted onto male appearance, dress, and behavior. The attributes of the Regency dandy (circa 1800)—deviant masculine consumption, nonreproductive irresponsibility, a rejection of middle-class gendering, a creation of the male body and home into a work of art—are firmly evinced in the macaroni type. As a foppish type, the macaroni also shares characteristics with the precursor, the seventeenth-century Restoration fop. The macaroni fashion preferences, however, were quite different and the two should not be conflated. The macaroni remains commemorated within the song *Yankee Doodle* (1767)—"Yankee Doodle Came to Town/Riding on a Pony./Stuck a feather in his cap/And called it Macaroni"—in which the appearance and masculine identity of the American troops is ridiculed within the theater of war.

See also **Dandyism; Europe and America: History of Dress (400–1900 C.E.); Fashion, Historical Studies of.**

### BIBLIOGRAPHY

Donald, Diana. *The Age of Caricature: Satirical Prints in the Reign of George III*. New Haven, Conn., and London: Yale University Press, 1996.



- George, Mary Dorothy. *Catalogue of Political and Personal Satires Preserved in the Department of Prints and Drawings in the British Museum*. Vol. 5, 1771–1783, London: Trustees of the British Museum, 1935.
- Lewis, Wilmarth S. *The Yale Edition of Horace Walpole's Correspondence*. Vol. 38. New Haven, Conn.: Yale University Press, 1937.
- McNeil, Peter. "‘That Doubtful Gender’: Macaroni Dress and Male Sexualities." *Fashion Theory. The Journal of Dress, Body & Culture* 3, no. 4 (1999): 411–447.
- Ribeiro, Aileen. "The Macaronis." *History Today* 28, no. 7 (1978): 463–468.
- . *Dress in Eighteenth-Century Europe, 1715–1789*, London: B. T. Batsford, Ltd., 1984.
- Steele, Valerie. "The Social and Political Significance of Macaroni Fashion." *Costume*, no. 19 (1985): 94–109.
- Stephens, Frederic George, and Edward Hawkins. *Catalogue of Prints and Drawings in the British Museum. Division I. Political and Personal Satires*. Vol. 14, A.D. 1761–A.D. 1770, London: Trustees of the British Museum, 1883.

Peter McNeil

**MACKIE, BOB** Bob Mackie was born in Monterey Park, California, on 24 March 1940. He attended Chouinard Art Institute in Los Angeles, but left after only two years to begin his career in costume design. In 1963 he teamed up with the costume designer Ray Aghayan for the television series *The Judy Garland Show*. For this project Mackie received his first screen credit and established a long working relationship with Aghayan. Mackie went on to design all the costumes for *The Carol Burnett Show* (1967–1978), while continuing to work on other television projects, such as *The Sonny and Cher Comedy Hour* (1971–1974). Throughout his career Mackie specialized in designing wardrobes for TV specials. His celebrity clientele brought him to Las Vegas, where he designed costumes for headliners and showgirls alike. Mackie has also provided costumes for numerous theater productions. His distinguished career has included seven Emmys and three Academy Award nominations. Over the course of four decades, he has dressed a dazzling array of celebrities including Diana Ross, Tina Turner, Madonna, and RuPaul.

### Costume Design

Two pervasive elements in Mackie's work are glamour and humor. His costumes for *The Carol Burnett Show* were instrumental to the program's character-driven comedy sketches. A perfect example of this is the "Starlett O'Hara" gown made of green velvet drapes—complete with curtain rod—which played a pivotal role in the "Went with the Wind" skit. The script had not called for the curtain-rod sight-gag, but the result was pure comedy genius and undoubtedly led to the skit's designation as one of "TV's Fifty All-Time Funniest Moments" by *TV Guide*. *The Carol Burnett Show* also provided Mackie



**Designer Bob Mackie with Cher.** Mackie's collaboration with Cher began in 1971 when he was hired to design the costumes for *The Sonny and Cher Comedy Hour*. © DOUGLAS KIRKLAND/CORBIS. REPRODUCED BY PERMISSION.

with the opportunity to dress an impressive array of guest stars, including Ethel Merman, Bernadette Peters, and Sonny and Cher.

In 1971 Mackie began work on *The Sonny and Cher Comedy Hour*, a series that amply displayed his distinctive design vision. Cher had met Mackie in 1967 when she was a guest on *The Carol Burnett Show* and asked him to provide costumes for her that would create a more mature, glamorous image. Cher's physical presence and her persona enabled Mackie to showcase his flamboyant designs without seeming too extreme. About her remarkable ability to wear his designs, Mackie once remarked: "There hasn't been a woman in the limelight since Garbo or Dietrich who could pull off such outrageous visual fantasies while maintaining her individual beauty" (Mackie, p. 176). *The Sonny and Cher Comedy Hour* proved to be a ratings bonanza, since viewers tuned in weekly to see what Cher was wearing. Using nude soufflé, a soft spongy fabric and strategically placed beads, Mackie's designs drove network censors and viewers wild by showcasing her long, slender torso with cropped tops and low-slung beaded

skirts. Her costumes were dripping with beads, feather, and fur, but Cher wore them with graceful nonchalance, as easily as if she were wearing a pair of blue jeans. With tongue firmly in cheek, she gamely accepted being dressed as a harem girl, an Indian princess, and even a snake. Cher is credited with making the “Mackie look” famous when she appeared on the cover of *Time* magazine in his nude soufflé gown in 1975.

Bob Mackie’s collaboration with Cher continued over the decades, and his designs for her became an integral part of her image. He has provided the memorable wardrobes for her many public appearances, including her 2002 Living Proof—The Farewell Tour. Tending toward the outrageous, he dressed her as Cleopatra for the launch of her fragrance, *Uninhibited*, and a “Mohawk Warrior” for the 1986 Academy Awards he provided the sheer catsuit worn in her infamous “If I Could Turn Back Time” music video. This ensemble, which gave viewers a good look at Cher’s tattooed derriere, was criticized as too risqué for daytime television, appearing on MTV only after 10 P.M. and sparked a national debate about decency standards. The “Mohawk Warrior,” with its bare midriff and high-feathered headdress, shocked many at the Oscars presentation, but for Cher, who felt snubbed by the Academy for not being nominated for her role in the film *Mask*, it pushed all the right buttons. Creating controversy through her choice of costume, Cher stole the show. Of Mackie’s designs she once remarked, “After we started working together, he just knew what I’d like. He walked the line between fashion and costume and that’s my favorite place to go” (Decaro, p. 67).

### Fashion Design

Mackie made the natural evolution into fashion design in 1982 when he launched a line of high-end ready-to-wear; today his empire includes furs, home furnishings, fragrance, a line of clothing sold on the cable shopping channel QVC, and a thriving made-to-order business. In 1990 Mackie began designing a highly successful line of collectible Barbie dolls for Mattel featuring his trademark style.

In 2001 Bob Mackie was honored with a special award for his “Fashion Exuberance” by the Council of Fashion Designers of America (CFDA). This was a particularly apt tribute, since Mackie’s lighthearted design philosophy has often run counter to the prevailing whims of fashion. Shrewdly understanding that the public associated his name with outrageous luxury and opulence, Mackie remained true to his aesthetic even at the height of early 1990s grunge. The beads, feathers, and furs that had been such an important part of his costume designs were translated into high fashion with heavily beaded evening dresses and dramatically draped chiffon gowns. His irreverent sense of humor, seen in so many of his costume designs, is also an important element in his fashion designs. This humor has translated into bugle-beaded wetsuits and jackets adorned with miniature racing cars.

Mackie’s whimsical approach to fashion is particularly apparent in a beaded minidress from 1988, which featured a trompe l’oeil beaded “bandana” at the halter-style neck. Never afraid to push a design concept to the limit, the cowboy-inspired dress was accessorized with a ten-gallon hat, boots, and gauntlets.

In 1999 Cher was honored with a CFDA award for her influence on fashion, an influence created largely by Mackie’s extraordinary vision. Through the power of television, Bob Mackie has made an important contribution to popular culture and helped to keep old-fashioned Hollywood glamour alive into the twenty-first century.

See also **Celebrities; Fashion Designer; Theatrical Costume.**

### BIBLIOGRAPHY

- DeCaro, Frank. *Unmistakably Mackie: The Fashion and Fantasy of Bob Mackie*. New York: Universe Publishing, 1999.
- Mackie, Bob, with Gerry Bremer. *Dressing for Glamour*. New York: A & W Publishers, 1979.
- McConathy, Dale, with Diana Vreeland. *Hollywood Costume: Glamour, Glitter, Romance*. New York: Harry N. Abrams, 1976.
- Morris, Bernadine. *The Fashion Makers*. New York: Random House, 1978.
- Reilly, Maureen. *California Couture*. Atglen, Pa.: Schiffer Publishing, 2000.
- Stegmeyer, Anne. *Who’s Who in Fashion*. New York: Fairchild Publications, 1996.

Clare Sauro

**MADONNA** Whether she is wearing navel-baring miniskirts, cone bras, or Gap jeans, Madonna has been a fashion leader since she became famous in the mid-1980s. As an icon of popular culture, she has set fashion trends and boosted the careers of established as well as up-and-coming designers. She has appeared on numerous fashion-magazine covers and has been a fixture at runway shows around the world. Her chameleonlike ability to regularly transform her look reflects both the ephemeral nature of fashion and Madonna’s redefinition of femininity; her styles have encompassed everything from punk to androgynous, s-m, hip-hop, geisha, western, and military looks.

### Early Life and Career

Born Madonna Louise Veronica Ciccone in Bay City, Michigan, in 1958, Madonna was one of six children raised in a strict Catholic home by her father; her mother died when Madonna was only five years old. Madonna was a cheerleader in high school. She acted in school plays and trained as a dancer. She attended the University of Michigan at Ann Arbor on a full dance scholarship but dropped out to pursue a professional dancing career in New York City in the late 1970s, where she studied with choreographer Alvin Ailey. Realizing that she instead wanted to

pursue a career as a singer and actor, she worked as a model, sang in the band The Breakfast Club, and starred in low-budget films such as *A Certain Sacrifice*. Her first success on the music scene came in 1983 with the release of her self-titled solo album; she released over a dozen full-length albums through 2003's *American Life*. Although best known as a singer, the multifaceted entertainer has also starred in numerous films, including the 1991 documentary *Truth or Dare*, and *Evita*, for which she won a Golden Globe in 1996; has been featured in Broadway productions; and has authored several books, including the controversial 1992 coffee-table work *Sex*.

Madonna's highly individual style was apparent in her debut on Music Television (MTV) in 1984. In her videos for "Lucky Star" and "Borderline," she wore her own version of punk—black miniskirt rolled down to expose her navel, mesh knit tank tops with her brassiere peeking through, black lace gloves, stiletto heels, a "Boy Toy" belt, rubber bracelets, teased hair with an oversized bow, and heavy makeup. Madonna's look spawned "Madonna wannabes"—legions of mostly young girls who copied her early style. The craze only heightened with her appearances in the 1985 movie *Desperately Seeking Susan* and on the MTV Music Awards ceremony the previous year, when she wore a white lace corset and "bridal" ensemble accessorized with her "Boy Toy" belt and strands of pearls, writhing onstage and singing the title track from her second album, *Like a Virgin*. Retailers like Macy's created "Madonnaland" and other Madonna-themed boutiques that sold Madonna-licensed clothing and accessories. Her look pervaded street styles of the mid-1980s and appeared in advertisements for fashion brands such as Benetton. The influence of this early look was still evident in the 1980s-inspired styles that appeared on runways almost two decades later; the popularity of navel-baring garments has only increased with the rise of young performers like Britney Spears and Christina Aguilera donning the look.

### Use of Past Fashion Icons

Madonna has looked to fashion icons of the past to create a persona. In her 1985 video for "Material Girl," she copied Marilyn Monroe's look from the film *Gentlemen Prefer Blondes*, in which Monroe wears a strapless, pink evening gown with matching long gloves, adorned with a lavish diamond necklace and earrings. She again resembled Monroe at the 1991 Academy Awards in her strapless, white, sequined Bob Mackie dress and Harry Winston diamonds. In the early 1990s Madonna imitated the androgynous look of the 1930s screen siren Marlene Dietrich, wearing menswear-inspired suits both in her videos, such as "Express Yourself," and while promoting her book *Sex* and her film *Truth or Dare*. For her 1990 video "Vogue," she mimicked the famous 1939 Horst P. Horst photo of the back of a woman in a loosely laced corset.

The corset became a dominant fashion theme in Madonna's look of the early 1990s. Madonna collabo-



**Madonna.** Since her appearance on the pop culture scene in the 1980s, Madonna has had an impressive influence on fashion, pioneering many eclectic styles. © STEVE GRANITZ/WIREIMAGE.COM. REPRODUCED BY PERMISSION.

rated with the controversial couturier Jean Paul Gaultier for her 1990 *Blonde Ambition* world tour. Known for his fetishistic fashions, Gaultier designed Madonna's memorable pink corset with cone bra for her 1990 tour. Not only did Madonna's wearing of exaggerated foundation garments (sometimes worn under menswear-inspired fashions as in the "Vogue" video) toy with accepted notions of femininity, it also launched the trend of underwear as outerwear still prevalent today, seen on celebrities and in street fashions alike.

### Collaborations with Designers

Madonna is known for befriending designers and for wearing and promoting the fashions of established as well as lesser-known designers. In addition to her collaboration with Gaultier, who also designed the neo-punk fashions she wore for her 2001 *Drowned World* tour, Madonna has worked with the Italian designers Dolce & Gabbana, who designed her clothing for the 1993 *Girlie Show* tour; she also wore their western styles in the videos and performances for her 2000 album *Music*. She was a





**Madonna on tour, 1990.** For her *Blond Ambition* tour performance in London, legendary music icon Madonna wears a white belted corset featuring a cone-shaped bustier, with black leggings. Rather than using the typical microphone, she employs a headset, making it easier for her to dance while singing. AP/WIDE WORLD PHOTOS. REPRODUCED BY PERMISSION.

friend to the late Gianni Versace, in whose 1995 advertising campaign she appeared, and she has often been seen in the front row of his sister Donatella's runway shows. Another close friend, the designer Stella McCartney, created a wedding ensemble for Madonna's 2000 marriage to the film director Guy Ritchie. Madonna has worn Azzedine Alaïa, Gucci, Givenchy, Alberta Ferretti, and Badgley Mischka, among others. She has also worn the fashions of designers before they were well known, such as Olivier Theyskens and Rick Owens, helping to boost their careers. In the fall of 2003 Madonna went from haute couture to mainstream, appearing in an advertising campaign for the Gap with the rapper Missy Elliot and wearing a white men's tank top, a newsboy cap, and Gap corduroy jean capris and a large amount of diamond jewelry.

Madonna's influence as a fashion leader has been consistent from the beginning of her career. Her style has been watched and followed from the moment she first ap-

peared on MTV. She has launched style trends such as wearing navel-baring fashions and underwear as outerwear, affecting the clothing choices both of other celebrities and the public at large. Her continual repackaging of herself has reflected her evolution as a woman and a performer. She has worn haute couture, supporting both known and unknown designers, and marketed mainstream fashions, with her looks encompassing different personas. The ubiquity of her unique and highly individual style makes Madonna an icon of modern fashion.

See also **Celebrities; Gaultier, Jean-Paul; Music and Fashion.**

#### BIBLIOGRAPHY

- Craughwell-Varda, Kathleen. *Looking for Jackie: American Fashion Icons*. New York: Hearst Books, 1999.
- Faith, Karlene. *Madonna: Badwy and Soul*. Toronto: University of Toronto Press, 1997.
- Hilfiger, Tommy, with Anthony DeCurtis. *Rock Style: How Fashion Moves to Music*. New York: Universe Publishing, 1999.
- McDowell, Colin. *Fashion Today*. London: Phaidon, 2000.
- Rubinfeld, Jenny. "Madonna Now." *Harper's Bazaar* (September 2003): 304.
- Steele, Valerie. *The Corset: A Cultural History*. New Haven, Conn.: Yale University Press, 2001.
- Taraborrelli, J. Randy. *Madonna: An Intimate Biography*. New York: Simon and Schuster, 2001.

*Tiffany Webber-Hanchett*

**MAINBOCHER** Main (after his mother's Scottish maiden name and pronounced like the New England state) Rousseau Bocher (his French Huguenot surname was pronounced Bocker) was born in 1891 on Chicago's West Side. Artistically inclined from childhood, he attended the Chicago Academy of Fine Arts and had moved to New York City by 1909 to study at the Art Student's League. Broadening his pursuits to include classical voice training as well, he departed for Paris and Munich, where he celebrated his twenty-first birthday. While studying music, he began sketching dresses for fashion designers to help support his mother and sister, who had joined him abroad. They returned to America at the onset of World War I in 1914, but not before three of Main Bocher's drawings were included in an exhibition at the Paris *Salon des artistes decorateurs*. In New York he financed his studies with the career-building vocal coach Frank LaForge through the sale of his sketches to another Chicago transplant, ready-to-wear manufacturer Edward L. Mayer. This marked the true beginning of his fashion career.

#### Editing Career

Back abroad in 1917 with a volunteer hospital unit, Bocher enlisted in the United States Army in the Intelligence Corps. Demobilized in France in 1918, he remained there and returned to singing. A vocal failure

during a pivotal audition finally forced him to abandon his operatic aspirations and to focus all of his creative attentions on fashion. He applied to the Paris office of *Harper's Bazaar* as a sketcher, then joined French *Vogue* in 1923 as the Paris fashion editor, became editor-in-chief in 1927, and resigned over a salary dispute in late 1929. With the financial backing of a discreet group of compatriots that included Mrs. Gilbert Miller, daughter of the American banker and art collector Jules Bache, he now turned his seasoned eye and editing skills toward the realization of his own fashion vision.

### Paris Salon

At a time when American designers had yet to establish credibility on their native soil, Mainbocher, his name now contracted in the manner of Paris-based couturiers Louiseboulanger and Augustabernard, opened his salon at 12, avenue George V. The impeccable designs and pristine dressmaking of this American-in-Paris proved irresistible, especially to the coterie of international hostess and taste arbiter Elsie de Wolfe. Through her influence Mainbocher was introduced to the most celebrated client of his young career, Mrs. Wallis Warfield Spencer Simpson. The international publicity surrounding the austere classic dress he devised for her Château de Cande wedding to the Duke of Windsor in June 1937 catapulted him to celebrity status, spawning a frenzy for "Wally" dress copies and the color "Wallis blue." His couture models were imported into the United States by elite establishments, including Hattie Carnegie, I. Magnin California, Saks Fifth Avenue's Salon Moderne,



**The Duke and Duchess of Windsor at their 1937 wedding.** Mainbocher designed the wedding dress for the duchess, which earned him instant popularity and inspired many imitations. © BETTMANN/CORBIS. REPRODUCED BY PERMISSION.



### DESIGN PHILOSOPHY

Throughout his forty-year career, Mainbocher's beliefs regarding the purpose and nature of clothing were inseparable from his work and were routinely incorporated into press coverage, providing a running philosophical commentary on his collections:

Between the beautiful classical that has proved its worth and some new stunt, I always choose the tried and true. I like persuasive dresses that have manners and I hate aggressive ill-bred concoctions (Bocher, 1938, p. 102).

A woman who has to remember to arrange any part of what she is wearing, simply cannot be smart. A well-dressed woman always appears to have forgotten what she is wearing.... To me, repose and natural ease are among the inimitable and essential attributes of the well-dressed woman (Bocher, 1950, p. 1).

and Jay Thorpe. By decade's end Mainbocher had become a pillar of the world of couture and in the process secured the adoration of a clientele who followed him back across the Atlantic upon his departure from occupied Paris in 1939.

### World War II

The fashion press celebrated the opening of Mainbocher's reincarnated salon at 6 East Fifty-seventh Street and his first American-designed collection late in 1940. The November 1941 *Harper's Bazaar* applauded his rigorous attention to maintaining all the traditions of his Paris house. Innovating ingeniously around daunting governmental restrictions (his invoices stating that his designs met with L-85 standards), his work remained fresh and appealing throughout the balance of World War II. During this period he featured glamour belts, aprons, and overskirts to vary the look of concise short or long black evening dresses. He launched a sensation for plunge-backed evening gowns and "Venus pink" with his Grecian designs for the 1943 Broadway production of *One Touch of Venus* starring Mary Martin. His surprising English cashmere sweaters, lined either in fur or coordinating silk, or jeweled, elegantly addressed wartime fuel conservation.

### Trademark Vision

The steadfast loyalty of his patrons and press withstood the challenge of the postwar return of French fashion and Christian Dior's triumphant "New Look" (a silhouette Mainbocher himself had presaged with his 1939 Victorian cinch-waist.) Mainbocher was as passionate about fabric as he was fastidious about craftsmanship and design. The opulent simplicity of his clothes weathered the ephemeral. His silhouettes nodded to trends yet remained true to Mainbocher. His archetypal vision of pedigreed, meticulous clothing was as readily transcribed into his polished 1950s designs as it was interpreted in architectural fabrics to relate his minimalist eloquence to the space-aged spirit of the 1960s.

### Famous Clients

Mainbocher's society client list included Daisy Fellowes, Diana Vreeland, Millicent Rogers, the Duchess of Windsor, Barbara Paley, C. Z. Guest, and Gloria Vanderbilt. He designed on and offstage wardrobes for Mary Martin, Katharine Cornell, Ethel Merman, Rosalind Russell, and Ruth Gordon.

Mainbocher closed the doors of his salon at 609 Fifth Avenue in 1971. Returning to Europe, he alternated his final years between Paris and Munich, where he died in 1976.

### Innovations

Although a self-described quiet innovator, Mainbocher succeeded in incrementally altering the complexion of contemporary fashion. As a fashion editor he initiated the "Vogue's Eye View" feature and introduced the terms *spectator-sports clothes* and *off-white*. As a couturier he promoted the nontraditional use of cotton gingham and lingerie crepe and glamorized cloth coats for evening use. His was the first strapless evening dress, which he executed in black satin in 1934. His wartime civilian and military contributions included "day length" evening dresses and adorned sweaters as well as uniform designs for the WAVES, the women's auxiliary of the Marine Corps, and the American Red Cross. In 1948 he designed the intermediate Girl Scout uniform.

See also **Evening Dress; Fashion Magazines; Uniforms, Military; Windsor, Duke and Duchess of.**

### BIBLIOGRAPHY

- Bocher, Main, "Mainbocher by Main Bocher," *Harper's Bazaar*, January 1938, 102–103.
- Carter, Ernestine. *Magic Names of Fashion*. Englewood Cliffs, NJ: Prentice-Hall, 1980.
- Lambert, Eleanor. *Quips and Quotes about Fashion: Two Hundred Years of Comments on the American Fashion Scene*. New York: Pilot Books, 1978.
- Lee, Sarah Tomerlin. *American Fashion: The Life and Lines of Adrian, Mainbocher, McCardell, Norrell, and Trigrère*. New York: Quadrangle/New York Times Book Company, 1975.

Milbank, Caroline Rennolds. *Couture: The Great Designers*. New York: Stewart, Tabori and Chang, 1985.

———. *New York Fashion: The Evolution of American Style*. New York: Harry N. Abrams, 1989.

Morris, Bernadine, "Mainbocher, Fashion Designer for Notables Since the 1930's, Is Dead in Munich at 85," *New York Times*, 29 December 1976, sec. A, p. 14.

*Phyllis Magidson*

**MAKEUP ARTISTS** In the media industries of fashion, film, television, and theater, an increasing number of runway shows, photographic shoots, and film and theater productions rely on the specialized skills of the makeup artist to communicate style and image.

When Maurice Levy designed the first retractable lipstick in 1915, no one could have guessed how popular cosmetics would become or how significant the role of the makeup artist would be in such emerging new fields as fashion photography and cinema production. Indeed, the concept of "makeup artist" hardly existed at the time. Until well into the twentieth century, theatrical performers were expected to do their own makeup, as they were expected to supply their own stage costumes. The professional makeup artist, like the theatrical or cinematic costume designer, is a modern phenomenon.

For much of the twentieth century, the role of the makeup artist remained a largely anonymous one, as audiences focused on the face of the model or actor rather than the makeup techniques that enhanced it. But makeup artists in fact have a great deal to do with how an actor or model looks in any given performance or production. The looks created evoke a theme, and it is important that the makeup be correct or else the artistic theme will be obscured or inaccurate, particularly when the makeup artist's task is to evoke a particular historical era or setting. While the image created by the makeup will always be paramount, by the early twenty-first century the makeup artist's expertise was receiving greater cultural recognition, and the role of the professional makeup artist had become a more conspicuous one.

Spaces where the made-up face is viewed include theaters, films, and photographs; the makeup artist's workplace is the dressing room, the film set, and the photographer's studio. The techniques of makeup used in these spaces are quite different from those of cosmetic makeup, and the professional makeup artist's skills are typically acquired over the course of a long period of training and practice. The heavy greasepaint and panstick used for theatrical makeup require special techniques for effective use. They are designed to work in harmony with strong lighting, which the makeup artist must anticipate while doing the makeup under weaker light. What might appear exaggerated and excessive in normal lighting will appear natural to a theatrical audience watching a performance on a lit stage. The applied shading and highlighting may be deliberately over-



emphasized by the makeup artist to increase the impact of the designed look for stage, screen, or catwalk.

Makeup artists build on their training, technical skills, and personal experience to develop an individual style. For example, Serge Lutens, who worked for many years with the Japanese cosmetics company Shiseido, prefers to be acknowledged as an artist who uses makeup. His style has been inspired by the cultures of China and Japan, and particularly by the highly artificial makeup of the Japanese *geisha*. He is famous for creating a geisha-like oval facial effect on the models he uses for photographic shoots. Lutens dramatically changes the faces of his models, and it is often impossible to recognize even the most famous models when he has made them up. Topolino is also recognized as an innovator in professional fashion makeup. Since the 1980s his work has broken the mold of established practice in fashion makeup, and he is known for his ability to create new looks every season for designers. Another makeup artist who has raised the prestige and visibility of the profession is Sarah Monzani, who designed the looks for the 1996 film *Evita*, starring Madonna. Some makeup artists have achieved star quality in their own right; some, such as Laura Mercier, have built upon their artistic success to become entrepreneurs in the cosmetics business. These successes have helped to establish a healthy reputation for expertise and creativity for the profession of makeup artist as a whole.

Makeup artists in the fashion industry have used conventions and techniques drawn from theater and film to expand their individual styles. The result has been a change in the face of fashion, on catwalks, in magazine editorial content, and in advertising. Prosthetic and special-effects products are used to adorn the face and the body. Feathers and crystals are used to morph the body from its human form and re-create it in statuesque or animal proportions. Makeup artists create ghostly or ghoulish looks that reference the horror film genre, and film noir is a fertile source used to create the femme fatale often seen in the pages of monthly fashion magazines.

The makeup artist today is not bound by traditional materials, styles, and conventions, but is able to call upon a wide range of techniques to create innovative effects. While new materials and techniques expand the range of possibilities available to the makeup specialist, the success of performed roles in theater, film, and fashion will continue to depend heavily on the skill and artistic vision of makeup artists.

See also **Cosmetics, Non-Western; Cosmetics, Western; Theatrical Makeup.**

#### BIBLIOGRAPHY

- Aucoin, Kevin. *Making Faces*. New York: Little, Brown, 1999.  
 Delamar, Penny. *The Complete Make-up Artist: Working in Film, Television, and Theater*. 2nd edition. Evanston, Ill.: Northwestern University Press, 2002.

Kehoe, Vincent. *The Technique of the Professional Make-up Artist*. New York: Focal Press, 1995.

*Elizabeth McLafferty*

**MALLARMÉ, STÉPHANE** The French poet and critic Stéphane Mallarmé was born in Paris in 1842 into a bourgeois family of civil servants. He was expected to follow into his father and grandfather's profession but, influenced by Charles Baudelaire and Théophile Gautier, he turned to writing poetry. After leaving school he went to England, and while in London, he married Marie Gerhard. They had two children, Geneviève and Anatole, who died at the age of eight.

Mallarmé taught English in Tournon, Besançon, and Paris until his retirement in 1893. Throughout Mallarmé's life his literary output was sparse and deliberate. His first poem was published when he was twenty-four. The famous "L'après-midi d'un faune" appeared in 1865, but between 1867 and 1873 his principal poems were left unfinished. From the 1880s he was at the center of a group of French artists that included Édouard Manet and Paul Valéry. Mallarmé died in Valvins, Seine-et-Marne, in 1898. His modernist masterpiece, "Un coup de dés jamais

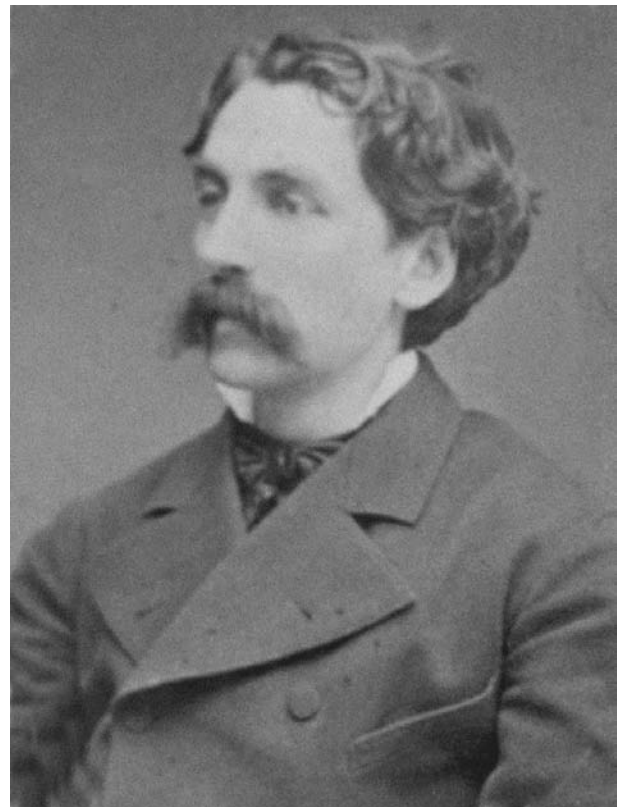

**Stéphane Mallarmé.** In his works, Mallarmé treated fashion as a unique and ever-evolving art form on the same level of importance as theater, writing, or painting. THE LIBRARY OF CONGRESS. PUBLIC DOMAIN.

n'abolira le hasard" (A throw of the dice will never abolish chance), was published posthumously in 1914.

### Unique Approach to Fashion

Mallarmé's relationship with fashion is marked by his association with the exponents of two literary movements of the late nineteenth century, the Parnassians and the symbolists. However, his is not the use of clothing or accessories as mere metaphors or symbols for character or sentiment, which occupied the literary output of his contemporaries. Mallarmé's singular contribution lies in his recognition of fashion as a social, cultural, psychological, and economic force in itself, and in the way in which this recognition finds poetical expression in different forms of writing, from occasional quatrain, via complex prose poem, to journalism.

### *La dernière mode*

Mallarmé's artistic expression found its most potent voice in journalism. In the autumn of 1874 he single-handedly wrote and edited a magazine entitled *La dernière mode* (The latest fashion). It was composed of a number of stylistically well-defined columns on such topics as couture, accessories, and hair and makeup. The poet wrote each of these columns under different female pseudonyms, slipping easily into each mode and adopting, with a mixture of reverence and irony, various poetical voices as well as mannerisms of the commercial prose of the Second Empire.

Albeit short-lived—only eight issues were published before it went into receivership—the richly illustrated *La dernière mode* became a *gesamtkunstwerk*, a total work of art on fashion and style, crossing and quoting artistic disciplines in the spirit of the *fin de siècle*.

### Fashion as Cultural Form

Mallarmé's development from a symbolist poet to a modernist writer, from an esoteric style to pared-down aesthetics, finds its unique expression in his attitude to fashion, to a mode dressing as well as sociocultural existence. There are, of course, a number of central subjects around which he built respective works, but fashion—with its haptic qualities, its shaping of the human form, and its metaphoric potential—appears as one of the most significant themes in Mallarmé's oeuvre. In what proved to be the last issue of *La dernière mode* (20 December 1874), he concluded, "No! for a compendium that intends to view fashion as art, it does not suffice to say 'this is what is worn'; one has to state 'this is the reasoning behind it'" (p. 2).

Here is Mallarmé's credo in regard to fashion. It is not simply an industry that creates material objects, nor is it a medium for a merely typified, gendered, or socialized representation. Fashion is a cultural form that demands critical investigation on a par with other artistic media, like plays, paintings, or novels. Moreover, it possesses a unique structure that lends itself to a redefinition of habitual rules and expressions. Mallarmé realized

that, just as he used and reused a hermetic, musical vocabulary, where words take on very different meanings or are brought into an alternative syntax, so fashion invents its own forms anew each season. The look of a familiar piece of clothing is changed beyond recognition, or its use is radically redefined. As a structuralist before the advent of structuralism, Mallarmé found in fashion a willful and skillful reshaping of formal appearances, and thus a technique that he himself pursued from his early, fragmentary poems (such as "Hérodiade" of 1869) to the open spaces of his late, formal experiment, "Un coup de dés jamais n'abolira le hasard."

### Fold and Word

Mallarmé's work is characterized by a quest for pictorial composition and at the same time by a forceful rejection of the subject. In fashion he found both his visual stimulus, through the colorful, sweeping fabric of French couture between the 1850s and 1890s, and a subject matter that was regarded as marginal within the contemporary cultural hierarchy. The topic of fashion allowed Mallarmé to work against narratives, to remain resolutely subjective within the nonlinear, associative rhythms of his verses, but, simultaneously, to remove himself from the sublime, weighty subjectivism that was considered necessary for symbolist poetry.

*La dernière mode* ran a dialogue with imaginary correspondents, where the poet celebrated the "profound nothingness" that pervades the life and sartorial consumption of the bourgeois female. Unlike Gustave Flaubert, Mallarmé used the seemingly empty existence and ennui of a female readership not for narrative drama, as Flaubert did with the character of Emma Bovary, but for a concentration on formal questions. Fashion, seen as insignificant and ephemeral by the cultural status quo, thus becomes a *carte blanche* for a poetically elaborate, yet curiously precise, description of fabrics, ribbons, pleats, and folds, as the journal aimed at fulfilling its commercial function as a source of sartorial information.

The fold in particular operates, as *pli modal*—an abstract fold that primarily exists in semantic form—in a material analogy to syntactic or stylistic innovation. Thus, a notion is either hidden within the surface of a specific word, or else one word refers to another unknown one and needs to be drawn from the depth of the linguistic fabric through combinative or connotative efforts. Fellow poets credited *La dernière mode* with the "invention of the word" (Burty, p. 587); indeed, the vocabulary in the journal surpasses the mere description of clothes or accessories and moves to constitute fashion in the abstract, as a verbal equivalent of sartorial innovations in contemporary haute couture.

### Female Voices

The professed independence from the material aspect of clothing, and the deliberate ignorance vis-à-vis stylistic minutiae, rendered *La dernière mode* less than commer-

cially viable among competitive fashion journals. However, the formal yet radical nature of its prose (such as the metaphysical musings of Marguerite de Ponty in her column, “La Mode”) and the irony of its stylistic quotations (repeated references by Miss Satin to Charles Frederick Worth and Émile Pingat) create a unique and extended text that floats unconstrained by a specific stylistic period. Indeed, the prose speaks as eloquently of the sartorial as of the literary form.

A further removal from the habitual approach of the artist to fashion, whether critical or celebratory, occurs through the exclusive choice of female pseudonyms. This technique was not new in itself. Honoré de Balzac and Jules Barbey d’Aureville, for example, preceded Mallarmé as “female” fashion journalists in the 1830s and 1840s. Yet Mallarmé does not hide behind or subsequently disavow his feminine personae but becomes them. A mental cross-dressing allows the poet to indulge in the transitory and ephemeral, unobserved by the patriarchal mainstream, and thus free to subvert a commercial medium for the dissemination of formal experiments to a readership hitherto unaccustomed to such an approach.

### Personal and Historical Impact

At the end of his life Mallarmé reminisced about the literary significance and the personal impact of the autumn of 1874. “I tried,” he said, “to write up myself clothing, jewelry, furnishings, even columns on theaters and dinner menus, a journal *La dernière mode*, whose eight or ten issues still, when I undress them from their dust, help me to dream for a long time” (Correspondence, Vol. 2: Paris: Gallimard, 1965, p. 303). Such remembrance, aided by fashion’s mode of existence in modernity as quotations from a past source book, prepared the ground not just for Marcel Proust’s literary form, but also for Walter Benjamin’s philosophy of history. The view of fashion in Mallarmé’s writing, therefore, accounts for the coming hallmarks of modernity itself.

See also **Baudelaire, Charles; Benjamin, Walter; Proust, Marcel.**

### BIBLIOGRAPHY

- Brown, Peter. *Mallarmé et l’écriture en mode mineur*. Paris: Lettres Modernes Minard, 1998.
- Burty, Philippe. Undated letter. In *Stéphane Mallarmé: Correspondence*. Vol. 4: 1890–1891. Paris: Gallimard, 1973.
- Deleuze, Gilles. *Le pli: Leibniz et le baroque*. Paris: Minuit, 1988.
- Dragonetti, Roger. *Un fantôme dans le kiosque: Mallarmé et l’esthétique du quotidien*. Paris: Éditions du Seuil, 1992.
- Faye, Jean-Pierre. “Mallarmé: L’Écriture, la mode.” *Change* 4 (1969): 56–57.
- Fortassier, Rose. *Les Écrivains français et la mode: De Balzac à nos jours*. Paris: Presses Universitaires de France, 1988.
- Kleinert, Annemarie. “La Dernière Mode: Une tentative de Mallarmé dans la presse féminine.” *Lendemain* 5, nos. 17–18 (June 1980): 167–178.
- Lecerle, Jean-Pierre. *Mallarmé et la mode*. Paris: Séguier, 1989.

Lehmann, Ulrich. *Tigersprung: Fashion in Modernity*. Cambridge, Mass.: MIT Press, 2000.

Lewis Shaw, Mary. “The Discourse of Fashion: Mallarmé, Barthes, and Literary Criticism,” *Substance* 68 (1992): 46–60.

Mondor, Henri. *Vie de Mallarmé*. Paris: Gallimard, 1941.

Nectoux, Jean-Michel. *Un clair regard dans les ténèbres: Peinture, musique, poésie*. Paris: Editions Adam Biro, 1998.

Peyré, Yves, ed. *Mallarmé, 1842–1898, un destin d’écriture*. Paris: Gallimard/Réunion des musées nationaux, 1998.

Thibaudet, Albert. *La poésie de Stéphane Mallarmé*. Paris: Gallimard, 1912.

Ulrich Lehmann

**MANNEQUINS** There are several historical strands that led to the development of the modern female fashion-display mannequin. From the fifteenth century, the miniature fashion doll (known as a “milliners’ mannequin”) was sent by dressmakers to wealthy customers, or exhibited for money by dressmakers to customers who wanted to copy the fashions. Other precursors of the fashion-display mannequin include artists’ lay figures (life-sized wooden dolls used by artists); anatomical wax models, used for teaching medicine; and, finally, tailors’ dummies. These examples utilized expertise in modeling representations of the human figure in wood, cane, papier-mâché, and/or wax.

The first wickerwork mannequins appeared in the mid- to late-eighteenth century and were made to order. In 1835 a Parisian ironmonger introduced a wirework model, and it was in France in the mid-nineteenth century that the first fashion mannequins were developed. Among the first mannequins to be patented were those designed by Professor Lavigne. He had begun manufacturing tailor’s dummies, but won a medal in 1848 for his patented trunk mannequin, and opened a mannequin house in France in the 1850s. He went on, together with a student of his, Fred Stockman (who founded Stockman Brothers in 1869, later Siegel and Stockman’s) to develop mannequins with legs and realistic heads and hands made from wax, improving on the earlier and cruder papier-mâché ones. When clothed, these wax mannequins appeared strangely lifelike, with features detailed down to individual hairs and glass eyes. The market for fashion mannequins quickly opened up with the department stores built in Paris in the 1850s and soon after that in America and Britain.

### The Fashioned Body

It was Paris that defined fashion from the mid-nineteenth until the mid-twentieth century, and the French mannequin manufacturers were able to exploit this reputation. Not only were French mannequins technologically advanced—fueled by the investment in shops and display in France—but notions of what was fashionable at any one point were centered on France, so French mannequins were considered the apex of fashion. Their new





**Mannequin in Indian clothing store.** As department stores opened in France, Britain, and the United States in the late nineteenth century before expanding worldwide, the fashion mannequin saw a rise in popularity. © DAVID H. WELLS/CORBIS. REPRODUCED BY PERMISSION.

designs were also regularly exhibited at the international expositions, with French models usually winning prizes, thus enhancing their fame and desirability.

The arrival of electricity was important to the appearance of the mannequin, as the faces of wax models would suffer in the heat of the window. It was imperative that new materials be found. In the 1920s, the French firm of Pierre Iman's perfected a lighter and heat-resistant material, "Carnasine," a plaster composite which would take the mannequin into a new, faster phase of change and mass production. By 1927 the French firm of Siégel and Stockman had some 67 factories in New York City, Sydney, Stockholm, and Amsterdam and had acquired agents in other parts of the world. They also employed the architect-designer René Herbst as an artistic advisor, and under his aegis the mannequin became an icon of the moderne style.

### The Artistic Body

At the end of the nineteenth century, the female mannequin had become a silent muse for artists and photographers who were appropriating mass culture as subject matter. The photographer Eugene Atget photographed shop windows, and later Erwin Blumenfeld photographed mannequins as though they were human. These images resonated with the Surrealists who would use mannequins as subjects: from Man Ray's photograph of a Siégel mannequin at the 1925 Paris Exposition des Arts Décoratifs, published in the *Révolution Surréaliste* magazine, to the sixteen mannequins dressed by different artists and writers (including Salvador Dalí, André Masson, and Eileen Agar) that were used as the central motif in a room at the Parisian Exposition Internationale du Surréalisme in 1938. The mannequin even became the subject of a film, *L'Inhumaine*, designed by artist Fernand Léger in 1924.

On the other hand, mannequin designers drew on ideas in works by artists such as Pablo Picasso, Marcel Duchamp, and Jean Cocteau, modeling mannequins with abstracted features and dislocated figures. The aesthetic that these extreme mannequins, usually French in origin, represented was one which appealed in particular to the elite boutiques, and it began to look outdated, as a new popular aesthetic swept in from America.

### The Iconic Body

In the 1920s and 1930s the American film industry was providing an international visual language that would influence both the design of window displays and the appearance of mannequins. By the 1930s American mannequin designer Lester Gaba had produced mannequins of the film stars Marlene Dietrich and Greta Garbo, and a Shirley Temple mannequin produced by Pierre Iman's was sold on both sides of the Atlantic. Film stars imparted glamour to the window display, which was itself looking more like a film set than ever. While World War II halted mannequin production in Europe, in

America production increased, and mannequins continued to reflect the American mass aesthetic. In their expansion, American firms like D.G. Williams and Lillian Greneker were aided by a material new to mannequin production—plastic.

In the 1950s, mannequins represented a sophisticated and grown-up glamour. It wasn't until 1966, when mannequin designer Adel Rootstein produced models of Twiggy and Sandie Shaw, that the emergent youth culture was reflected in shop windows.

### Mannequins Now

In the late-twentieth century, supermodels and television stars served as models for fashion mannequins. Conversely, the mannequin again became a subject for artists as fashion photographer Deborah Turbeville featured mannequins extensively in her work, and fashion illustrator Ruben Toledo designed a plus-sized mannequin for manufacturer Pucci. Mannequins have also captured the interest of designers like Alexander McQueen, whose innovative shop windows provide alternatives to the ubiquitous visual merchandising of the large fashion chains.

See also **Fashion Advertising; Fashion Dolls.**

### BIBLIOGRAPHY

- Adburgham, Alison. *Shops and Shopping: 1800–1914*. London: Allen and Unwin, 1964.
- Gronberg, Tag. *Designs on Modernity: Exhibiting the City in 1920s Paris*. Manchester: Manchester University Press, 1998.
- Parrot, Nicole. *Mannequins*. New York: St. Martin's Press, 1982.

*Jane Audas*

**MANTUA** The following definition of mantua was published in a book that recorded symbols for coats of arms and was compiled in 1688 by Randle Holme, a third-generation craftsman in that field. It is the earliest known definition of the style:

A Mantua is a kind of loose Coat without any stays in it, the body part and sleeves are of as many fashions as I have mentioned in the Gown Body; but the skirt is sometime no longer than the Knees, others have them down to the Heels. The short skirt is open before, and behind to the middle: this is called a Semmer, or Semare: have a loose Body, and four side laps or skirts; which extend to the knee, the sleeves short not to the Elbow turned up and faced.

The mantua style was introduced in the 1670s and remained fashionable until the beginning of the eighteenth century. Distinctive features of the mantua are its loose-fitting unboned bodice and the fact that it was cut in one length instead of cutting the bodice and skirt as two separate pieces. The loose-fitting over robe with a train was draped up and pulled back to reveal the petticoat. It was unboned but worn with a corset. The mantua is thought to have originated as informal dress to

provide relief from the heavily boned bodices of the *grand habit* that was the style at court. The mantua had a kimono-like construction inspired by imported Indian robes worn as dressing gowns in Europe. In its earliest form, the mantua was constructed of two long pieces of fabric that ran from the front hem over the shoulders and down the back to the hem of the train. The textile was cut only minimally—at the neck and under the arm to the waist. It was recognized that styles would change and it was advantageous to have as much fabric available to convert it to the new style. Its one-piece construction formed the basis of much of women's clothing in the eighteenth century. Sack gowns of the early eighteenth century directly evolved from the mantua style.

Its loose fit and reference to dressing gowns gave the mantua an air of undress that Louis XIV considered too informal to be worn at French court functions. The mantua was supposed to be worn only in one's own chamber or at specific country residences of the court. Despite royal disapproval of the style, the mantua was the height of fashion in town and became the dominant fashionable garment for women through the beginning of the eighteenth century. Another important distinction from the *grand habit* of the court was that the mantua covered the shoulders. Ladies appreciated the warmer, more comfortable style over the off-the-shoulder cut of the *grand habit* which had to be worn no matter what the temperature.

As the mantua evolved it became more formalized and was accepted at court. The loose folds of the bodice were stitched down into pleats for a closer-fitting shape. Eventually it was allowed for all but the most formal occasions at court, and even crystalized in varied forms as court dress in England through the eighteenth century.

The overall appearance, textile, trimmings, and accessories of a mantua were far more important than the fineness of its construction. The largest portion of the cost of any new garment in that period was the fabric. Careful consideration was given to the cutting of the textile and placement of dominant motifs, but the inside stitching was sometimes quite coarse and uneven. Distinctive brocaded silk damasks now known as *bizarre* silks, fashionable from circa 1695 to 1720, were often used for the mantua. Characterized by elongated, asymmetrical patterns that combined natural and abstract motifs, *bizarre* silks used bold color combinations and textured gold and silver metallic threads. The combination of textures and colors of these textiles created spectacular effects in a mantua's flowing appearance. The surface of gold and silk threads change with movement, casting light and dark within the free folds of the draped train.

The interest in scientific and technical experimentation, and the influence of exoticism from imported goods from the East, coupled with the increasing demand for luxury and change of the late seventeenth century, came together to create free and dazzling *bizarre* silk designs. The vertical lines of the mantua complemented the long, flowing lines and large repeats of the *bizarre* silks. An av-

erage vertical repeat of a *bizarre* silk at the height of the movement was nearly 27 inches, 10 across (69 centimeters and 26 centimeters across). Commonly, the design repeated across the width of the textile twice.

Mantua makers used a combination of flat cutting and draping. First, the pieces of the garment were cut from the fabric according to measurements taken from the client. Second, the long center back seam was sewn with close stitches in the bodice, and long loose stitches below the waist. The bodice area that fits more closely and takes more stress with movement than the lower parts requires closer stitching. Side gore pieces would have been added to the sides of the main panel to make the dress wider below the waist. These seams were sewn in two different ways depending on whether the mantua was of the lined or unlined style. If the mantua was lined, the seams were sewn in the conventional manner of placing the right sides together leaving the outside with a clean finish. If the robe was unlined these seams would have been sewn wrong sides together so that the seam allowances were on the outside of the dress. The draping back of the front edge of the mantua positions the inside of the mantua to the outside in this area. Fabrics that were attractive on both sides were joined with special mantua-makers seams giving both sides a clean finish for the draped arrangement of the skirt of the mantua.

See also **Coat; Europe and America, History of Dress (400–1900 C.E.)**.

#### BIBLIOGRAPHY

De Marly, Diana. *Louis XIV and Versailles*. New York: Holmes and Meier Publishers, Inc., 1988.

*Dennita Sewell*

**MAO SUIT** This suit comprises a front-fastening jacket, buttoned to the neck, and a pair of trousers in matching material. Its main association is with communist China. It is named in English after Mao Zedong (1893–1976), the leader of the People's Republic of China from 1949 to 1976. Its salient features are a high, turned-down collar that fits the neck closely, and four patch pockets, two large ones at waist level and two smaller ones on the breast. A classic Mao suit has expandable lower pockets, and both the top and bottom pockets close with a buttoned-down flap. The trousers have a waistband, with a fly-front fastening for men and a side fastening for women. The suit can be made from a variety of materials with cotton, polyester, or a mix of the two being the most usual. It is almost always blue, though within that spectrum the colors range from pale gray to dark blue-black. The suit is often teamed with a matching worker's cap. Mao suits can either be purchased off-the-rack or tailor-made.

Despite its name, Mao was not the first person to wear such a suit. Its precise origins are hard to pin down.



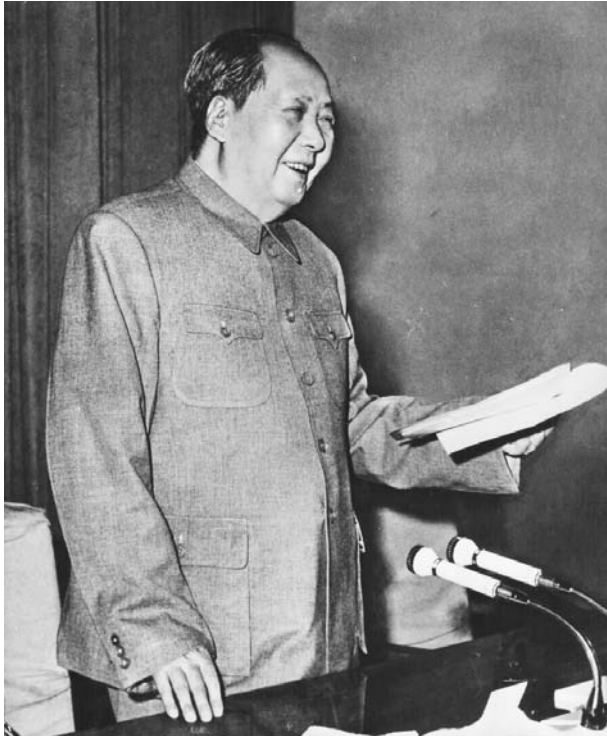

**Mao Zedong.** Mao wears the suit named after him. The Mao suit was nearly always a shade of blue-grey and was the preferred ensemble of government officials. HULTON/ARCHIVE. GETTY IMAGES. REPRODUCED BY PERMISSION.

In the early years of the twentieth century, as an alternative to both the long gown and the western suit with collar and tie, several different styles, similar to the Mao suit but with a high-standing collar and no patch pockets, began to be worn by Chinese men. These have been viewed as precursors of the Mao suit and are called student suits because they were first adopted in Japan by Chinese studying there. The student suit, which had derived from European, probably Prussian, military dress, became linked with those urging political and economic reform for China. Another famous Chinese leader, Sun Yat-sen (1866–1925), revered by Chinese the world over as the “Father of the Nation” for his part in creating a Chinese Republic in 1911, is credited with making adaptations to the student suit, although it still did not look like the Mao suit we know today. It was in the 1920s that Sun himself appeared in what we now perceive as a fully fledged version of the Mao suit with patch pockets. This followed on a more overt link with Soviet communist advisors, who also wore this type of suit.

See also **China: History of Dress; Politics and Fashion.**

#### BIBLIOGRAPHY

Roberts, Claire, ed. *Evolution and Revolution: Chinese Dress, 1700s–1900s*. Sydney: Powerhouse Publishing, 1997.

Steele, Valerie, and John S. Major, eds. *China Chic: East Meets West*. New Haven, Conn.: Yale University Press, 1999.

Verity Wilson

**MARGIELA, MARTIN** Martin Margiela (1957– ) was born in Hasselt, Belgium. He studied fashion design at the Royal Academy of Fine Arts in Antwerp—at the same time as Ann Demeulemeester—followed by a three-year apprenticeship with Jean-Paul Gaultier (1984–1987). He established the Maison Martin Margiela in Paris in 1988, together with Jenny Meirens, a boutique owner. Margiela was categorized more than once as the deconstructivist par excellence in a period when the term was applied indiscriminately to designers whether or not it was appropriate. Margiela was probably one of the few designers in the early 2000s whose work could be fairly described as deconstructivist. His investigation into the different aspects underlying any article of clothing, such as form, material, structure, and technique, were central to his entire body of work. His work was deconstructivist because he took not only the garment itself into consideration, but also the system that produced it. Ideas about haute couture, tailoring, high or low fashion, innovation, and commercialism do not arise from any apolitical standpoint, nor are they formulated as criticisms of established fashion assumptions. Margiela’s work began from a set of analyses questioning the established theories of what already exists in order to search for alternatives that can be brought to life, both within and outside the system.

Margiela’s attention to tailoring often exposed the production process behind the clothing, or revealed techniques that traditionally remain hidden in its production. The experimental aspect of his clothes in fact did not take place at the expense of ease in wear or aesthetic considerations. Margiela’s summer collection for 2004 included blouses and dresses whose forms were no longer determined by classic lines or cut, but rather by small black stitches that stood out sharply against the fabrics he selected. The pleating and folding techniques that formed the starting point for his 2002 and 2003 collections were further developed in the 2004 garments. The tiny stitches were applied with surgical precision in order to achieve the correct fit. The result was elegant, slightly aggressive, yet simultaneously a tribute to the work of the many professionals in the field of fashion who remain literally unseen.

The study of form was equally central to Margiela’s 1998 summer collection, which was a series of “flat garments.” When the pieces are not being worn, they seem to preserve the two-dimensional structure of the paper pattern. The armholes were not placed at the sides of these garments, but rather cut out of the front section. Only when the flat garments are put on does their actual three-dimensional form appear. A second collection worthy of note in this regard was Margiela’s summer 1999

collection. The basic idea was to reproduce a series of doll clothes enlarged to human size. The designer retained the disproportions and finishing details, however, resulting in rather alienating pieces with giant buttons and zippers.

In 1997 Margiela based two successive semi-couture collections on an old Stockman tailor's dummy. Various elements that pointed to subsequent stages of the production process, such as the sections of a toile, for example, were permanently pinned to the bust as part of a jacket. Other jackets assumed a masculine shoulder line, with the inside of the prototype replaced with a second structure and with a feminine shoulder line. Removing the sleeves revealed both the masculine and the feminine tailoring. Shoulder pads were sometimes placed on the outside of the garment or used as a separate accessory: the inside became the outside.

This process of reversal also applied to other aspects of the designer's work. The use of recycled materials was particularly evident in Margiela's early collections. In his first winter collection, displayed in 1988, shards from broken plates were worked into shirts. Plastic shopping bags were cut to form tee-shirts and held together with brown cellophane tape. In the summer 1991 collection, secondhand ball gowns from the 1950s were dyed gray and given new life as waistcoats; old jeans and denim jackets were reworked to become elegant, full-length coats.

Margiela's reversals were more frequently a source of confusion. In his 1996 summer collection, photographs of garments, knitted goods, sequined evening wear and different fabrics were printed onto lightweight cloth with a subtle fall, which was in turn worked into simply cut designs. The very realistic printing created a trompe-l'oeil effect or optical illusion and suggested tailoring that the actual pieces did not have. The models wore cotton voile during the show to cover their faces and hair. Hiding the physical features that make a person unique increases the desire for identity and uniqueness evoked by the clothing itself.

The most noteworthy detail in Margiela's clothing was the nameless, somewhat oversized white label, identifiable on the outside of the garment by four white stitches attaching its corners. The label itself carried neither brand identification nor size indication, and therefore seemed utterly extraneous. The conspicuousness of the white stitches increased the visibility of something that at first did not seem intended to attract attention. The phenomenon of merchandise branding was thus referenced in all its complexities and ambiguities. Margiela's refusal to supply his designs with a brand name produced the opposite effect, a select in-crowd who recognized his "brand." In similar fashion, Margiela the designer wished to disappear behind his work in a decade characterized by extreme narcissism, in which other designers attained superstar status. No photographs of the designer were distributed. Communications concerning the collections consistently took place only through Maison Margiela.

Interviews were allowed only by fax, and were always answered in the first person plural. This created an ambiguous result as well. Margiela's refusal to appear in person resulted in the creation of a personality myth.

Maison Margiela seemed to rebel against the rhythm of production that the economic system imposes on designers, not by radically rejecting the system but by filling it in with its own table of contents. In the strictest sense, the house's collections and its various sideline activities are not bound to trends or seasons. Consequently, the tabi boot—a Japanese-inspired shoe in the form of a hoof—reappeared with each new season, albeit in slightly modified form. Moreover, not only were existing garments reworked into new creations, but also the "success items"—or favorite pieces from previous collections—were repeated. This method led to the evolution of different lines, each of which was given a number that referred to differences in content, working method, and technique. All the lines except 1—the main line for women—bore labels printed with a line of numbers from 0 to 23 and the relevant number was circled.

Margiela was engaged in 1997 as the in-house designer for Hermès, one of the greatest luxury houses of France, with an established reputation for quality and finishing. Here, too, Margiela succeeded in further developing the achievements of his characteristic investigations into tailoring, although he worked entirely within the Hermès atmosphere and tradition. The interpretation that Margiela contributed to Hermès was a guarantee of absolute quality and excellence in luxury productions in leather and cashmere. No busy prints were to be found, but rather a return to the article's essence, and the core of true luxury, that is, the stripping away of everything that is not essential.

Where the inside was brought outside in more experimental fashion in Margiela's own collections, the inside was also central to flawless finishing in his work for Hermès. Maison Margiela introduced line 4 in 2004, which appeared to be an in-between collection that bridged Margiela's work for his own house and his work for Hermès. Collection 4 represented a reworking of a number of pieces from line 1, with inside finishing placed on the outside of the garment but now executed in more traditional and luxurious form, as was customary in the Hermès tradition. Only the neck and shoulders of these garments were provided with a lining. Margiela left Hermès after the 2004 spring–summer collection.

See also **Belgian Fashion; Brands and Labels; Demeulemeester, Ann; Gaultier, Jean-Paul; Grunge; Hermès; Recycled Textiles.**

#### BIBLIOGRAPHY

Evans, Caroline. "The Golden Dustman: A Critical Evaluation of the Work of Martin Margiela and a Review of *Martin Margiela: Exhibition (9/4/1615)*." *Fashion Theory* 2 (1998): 73–93.

Gill, Alison. "Deconstruction Fashion: The Making of Unfinished, Decomposing and Reassembled Clothes." *Fashion Theory* 2 (1998): 25–49.

Street Editorial Office. *Maison Martin Margiela Street Special Edition*. Vols. 1 and 2. Tokyo, Japan: 1999.

Te Duits, Thimo, ed. *La Maison Martin Margiela: (9/4/1615)*. Rotterdam, Netherlands: Museum Boijmans Van Beuningen, 1997.

Vinken, Barbara. "Mannekin, Statue, Fetisch." *Kunstforum International* 141 (Juli–September 1998): 144–153.

*Kaat Debo and Linda Loppa*

**MARIMEKKO** Marimekko, the textile, apparel, and interior design company, was founded in Helsinki, Finland, in 1951 by the husband-wife team, Armi and Viljo Ratia, as an outgrowth of Printex, their oilcloth manufacturing company purchased in 1949. As the artistic director, it was Armi's decision to use the colorful, nonfigurative patterns designed by Finnish artist Maija Isola, which were silk-screened by hand on cotton material. It was difficult to get consumers to understand these new types of designs, as they were completely different from the traditional floral fabrics. Armi came up with the idea of using the fabrics in a collection of dresses, whose bright colors and simple style were warmly embraced in post–World War II Finland.

The name Marimekko, which translated means "little dress for Mary," comes from two words: *mekko* meaning a peasant woman's simple dress and *Mari*, the Finnish form of Mary or Maria, which is the eternal name for the eternal woman. The essence of Marimekko from the beginning was a certain way of dressing—a simple, comfortable, cotton dress that exemplified the Finnish ease of lifestyle.

One of the psychological factors behind the popularity of Marimekko design is its elemental diversity. Marimekko has offered the possibility of totally contrasting associations and identifications. It has fused traditionalism and radicalism, decorativeness and asceticism, anonymity and difference, the ordinary with the festive, and pure Finnish rural with international city style. At its peak, the design managed to appeal equally to young radicals and old intelligentsia, to a new breed of career woman as well as old-school housewives.

### Marimekko in the United States

Marimekko soon found a large, enthusiastic audience in the United States. Architect Benjamin Thompson, founder of Design Research (D/R) in Cambridge, Massachusetts, saw Printex fabric and Marimekko dresses at the Brussels World's Fair of 1958. When D/R prepared for an American exhibit of Finnish design in 1959, Armi Ratia arrived with two cardboard boxes of dresses and fabrics, that were an immediate hit. Ben Thompson's reaction to this was: "Marimekko certainly belonged at Design Research. Nothing like it had been seen in America.

It matched the mood of the times" (*Subonen*, p. 110). When Jacqueline Kennedy purchased seven Marimekko dresses to wear during the 1960 Presidential campaign, it was reported in 300 U.S. newspapers, making Marimekko a household name. In the 1960s, Marimekko was celebrated worldwide for its apparel and textiles that reflected the events and current trends of the decade: Op and Pop Art, flower power, student revolts, and the conquest of space.

### Marimekko Since 1979

With Armi Ratia's death in 1979, the future of Marimekko seemed uncertain. In 1985 Marimekko was sold to Amer Group Ltd., and later was acquired by Kirsti Paakkanen in 1991. By 2004 Marimekko had become a public company with some 800 retailers around the world, and was experiencing a revival with a new generation of consumers.

### Designers

**Maija and Kristina Isola.** Maija Isola (1927–2001) started working for Printex in 1949 and for Marimekko in 1951, where she continued to design fabrics until 1987. One of her most popular designs is *Unikko*, the large and colorful flower originally designed in 1965. In more recent years, it saw a huge revival and its popularity has made it an inadvertent trademark for Marimekko. Maija's daughter, Kristina Isola, joined Marimekko in 1964 and worked with her mother until 1987. She has updated some of her mother's original designs with new adaptations and colors, as well as creating new designs of her own. In 2000, *Pieni Unikko* was created using the original flower in a smaller scale in new colorways.



### ARMI RATIA AND MARIMEKKO

Armi Ratia (1912–1979) was the driving force behind the early success of Marimekko. The combination of her education as a textile artist and her work experience in public relations was a definite advantage to the company. At first Armi served as the Artistic Director, but eventually she became Marimekko's Managing Director. An idealist and a visionary, Armi was unafraid of taking risks. These assets combined with intelligence and a forceful personality made Armi capable of making Marimekko a successful business, but also of shaping it to become a cultural phenomenon. She served as an unofficial ambassador for Finland through worldwide representation of the company and by entertaining clients and guests lavishly at her summer manor house, Bökars.





**Striped Marimekko cosmetic bags, 1996.** Marimekko, a famous Finnish textile company, is known for having introduced modern patterns, beyond traditional floral prints, into the world of fashion. © STEVE RAYMER/CORBIS. REPRODUCED BY PERMISSION.

***Vuokko Eskolin Nurmesniemi.*** Vuokko Eskolin Nurmesniemi (b. 1930) became Marimekko's chief clothing designer in 1953 and worked for the company until 1960. Vuokko's design concept for Marimekko remained into the twenty-first century: easy-to-wear clothing that has a minimum of buttons, darts, and detailing. In 1953 she designed *Piccolo*, a striped fabric that was produced in 450 colorways. A few years later, it was used in the creation of *Jokapoika*, or "Everyboy," a plain Finnish farmer's shirt, commonly known in the United States as the Finn Farmer shirt. In 2004, the *Jokapoika* shirts were still in production.

***Annika Rimala.*** Annika Rimala (b. 1936), the main clothing designer at Marimekko from 1959 to 1982, wished to produce clothing that was timeless, that represented ease in lifestyle, that was available from one year to the next, and that was suitable for men, women, and children alike. Inspiration for her famous *Tasaraita*, "even-stripe," cotton jersey T-shirts came in the 1960s when Levi Strauss blue jeans, formerly work clothes, became that of casual, everyday wear. Hence, the colorful even-stripe T-shirt replaced that of the classic solid color

T-shirt of the miner, and was worn by the "younger generation" worldwide. It has been among Marimekko's top sellers since 1968.

***Fujiwo Ishimoto.*** Fujiwo Ishimoto (b. 1941) began working as a textile designer for Marimekko in 1974, after first working for the company Decembre, set up by Risomatti Ratia, son of Marimekko's founders Armi and Viljo Ratia. Inspired by both Asian art and culture and Finnish traditions and nature, Fujiwo's abstract designs for textiles led the Marimekko line in the 1970s and 1980s, a change from the playful designs of the 1960s that had made Marimekko famous. Among his designs licensed for production in the United States is *Kukkaketo* (1975), a flower print used in bed linens.

***Katsuji Wakisaka.*** Katsuji Wakisaka (b. 1944) worked as a textile designer for Marimekko from 1968 to 1976. Among his best-known designs is *Bo Boo*, a children's pattern designed in 1975 and composed of cars, buses, and trucks printed in primary colors that became an immediate Marimekko classic. Although originally designed for printed fabrics, *Bo Boo* provided the basis for a wide se-

lection of articles ranging from towels, sheets, and bags to glassware, ceramics, and toys. It became the most popular Marimekko pattern used in licensed production in the United States.

**Risomatti Ratia.** Risomatti Ratia (b. 1941), son of founders Armi and Viljo Ratia, worked for Marimekko from 1973 to 1977 and its subsidiary, Marimekko Inc., from 1977 to 1984. In 1971 he designed *Olkalaukku*, one of the most beloved and widely sold canvas bags in Marimekko history. From this design came a collection of bags made in a firm cotton canvas available in the timeless colors of black, navy blue, bright red, and khaki gray. The line comprises several types of carryalls, briefcases, shoulder bags, purses, coin purses, and cosmetic cases.

See also **Art and Fashion; Traditional Dress; T-shirt.**

#### BIBLIOGRAPHY

Suhonen, Pekka, and Juhani Pallasmaa, eds. *Phenomenon Marimekko*. Porvoo, Finland: Marimekko Oy, 1986.

*Marilee DesLauriers*

**MARKS & SPENCER** One of the best-known United Kingdom chain stores selling its own-brand merchandise, Marks & Spencer (M&S) made a substantial contribution to the democratization of fashion in the twentieth century: the provision of competitively priced, quality clothing. Before a downturn in the company's profits at the end of the 1990s, M&S's share of the U.K. clothing market stood at 14.3 percent with a turnover of £8.2 billion and nearly 300 stores in Britain alone.

#### Early Development

The company's founder, Michael Marks (1863–1907) was a Jewish immigrant who left Bialystok in Russian Poland in the 1880s for England and began work as a licensed hawker selling his wares in the Yorkshire countryside. Marks then opened market stalls selling a diverse range of household and personal items, all at the uniform price of a penny (1d). Marks went into partnership with Tom Spencer and together they formed a limited company in 1903 (hence Marks & Spencer). By the eve of World War I, there were more than 140 branches of the Marks & Spencer Penny Bazaar Chain.



**Marks & Spencer, November 2001.** Shoppers emerge from the Marks & Spencer store on Oxford Street in London, carrying their purchases. The chain store was one of the pioneers in the democratization of fashion, with its moderately-priced, own-brand quality clothing. AP/WIDE WORLD PHOTOS. REPRODUCED BY PERMISSION.

### The Launch of Clothing

During the interwar period, with the declining importance of market stalls, shops became the preferred retailing outlet. Influenced both by a fact-finding trip to the United States, and by the increasing demand for ready-made clothing from a working-class market, Michael Marks's son, Simon Marks (now leading the M&S business), concentrated on building a direct relationship with U.K. clothing manufacturers and cutting out the wholesaler in order to reduce prices and have greater control over the quality of goods. At the head office (London), a Textile Laboratory was established in 1935, followed by Merchandise Development and Design Departments in 1936 to improve the quality and design of garments. By 1939 the company was selling excellent quality underwear and an expanding range of clothing for men, women, and children.

Following World War II, M&S's emphasis was on retailing easy-care and stylish clothing manufactured from the new synthetic fabrics (for example, Nylon, Terylene, Orlon, and Courtelle). More focus was placed on design by employing designers as consultants, such as the Paris-based Anny Blatt in the 1950s (for women's jersey wear) and Italian Angelo Vitucci in the 1960s (for menswear). The company began a major phase of international expansion in the 1970s by opening stores in Europe, Canada, and later Hong Kong. For a short time, it acquired the well-known Brooks Brothers chain (1988).

### Marketing and Advertising

In 1928, M&S registered the St. Michael brand name, probably the company's most successful single marketing decision. For the next 70 years, only goods with the St. Michael label would be sold in M&S stores. Advertising in the modern sense began in the 1950s. For a short time in the 1990s the company used supermodels to sell its clothing. The optimism of the early to mid-1990s and the praise M&S received for the quality and design of its clothing ranges at this time soon disappeared in the context of competition on the high street from companies with narrower and more clearly defined markets such as Gap and Jigsaw on the one hand, and the discount retailers such as Matalan on the other.

### Recent Developments

Led by chairman Luc Vandeveld into the twenty-first century, and with the injection of design talent into womenswear via George Davies's Per Una range (launched autumn 2001), Marks & Spencer made a substantial recovery. Nevertheless, it is the opinion of some that "however well the company does, it will be a long time, if ever, before it regains its past reputation for unassailable excellence or is, once again, regarded as the benchmark of retailing standards" (J. Bevan, *The Rise and Fall of Marks & Spencer*, p. 262).

See also **Department Store; Fashion Marketing and Merchandising.**

### BIBLIOGRAPHY

- Bevan, Judi. *The Rise and Fall of Marks & Spencer*. London: Profile Books, 2002. Good on the particular circumstances leading to Marks & Spencer's fall in profits at the end of the 1990s.
- Rees, Goronwy. *A History of Marks & Spencer*. London: Weiderfeld and Nicholson, 1969. Good overview of Marks & Spencer's early development from a business history perspective.
- Worth, Rachel. "Fashioning' the Clothing Product: Technology and Design at Marks & Spencer." *Textile History* 30, no. 2 (1999): 234–250. Concentrates on the clothing aspect of the business with particular focus on the role of design and technology.

Rachel Worth

**MARX, KARL** Karl Marx was the major critic of capitalism in the nineteenth century, and he proposed, in its place, a society organized around need rather than profit. One of his main works is a three-volume study called *Capital*, which is a study of the political economy of capitalism. Fashion is at the core of Marx's political economy. Marx identified "modes of production." These are successive epochs of technical and social arrangement, which alter the organization of production and consumption. These modes have something of fashion's logic about them, if fashion is taken to be the latest trend, against which all else is considered outmoded. More specifically, in Marx, fashion's rhythms equate with the breakneck pace and whimsicality of industrial capitalist production, which *Capital* indicts: "The murderous, meaningless caprices of fashion" (1976, p. 609), employing and dismissing workers at whim, are linked to the general "anarchy" of capitalist production. Marx mentions "the season," with its "sudden placing of large orders that have to be executed in the shortest possible time" (1976, p. 608). This phenomenon intensified with the development of railways and telegraphs. Marx quotes a manufacturer on purchasers who travel every two weeks from Glasgow, Manchester, and Edinburgh to the wholesale warehouses supplied by his factory. Instead of buying from stock as before, they give small orders requiring immediate execution: "Years ago we were always able to work in the slack times, so as to meet demand of the next season, but now no-one can say beforehand what will be in demand then" (1976, p. 608). Employment and livelihood are dependent on fashion's vagaries.

Not simply analog to the rhythm of the capitalist mode of production, fashion—or clothing—was, for Marx, the very generator of the Industrial Revolution. The textile industry inaugurated the factory system of exploitation. In the cotton mills of the mid-nineteenth century, men, women, and children labored cheaply, six days per week, spinning materials harvested by slaves in the United States. In the silk mills child labor was even more grinding: ten-hour shifts and exemption from otherwise compulsory education. The need for a light touch when



working with delicately textured silk was apparently only acquired by early introduction to this work.

In another vein, Marx deployed fashion metaphorically. Discussing the first French republic, he noted how it “was only a new evening dress for the old bourgeois society” (1992, p. 48). Elsewhere, Marx described the reactionary nature of the French politicians who were establishing modern bourgeois society. They adopted “Roman costume” and “Roman slogans” (1992, p. 147). These are “self-deceptions” necessary “to hide from themselves the limited bourgeois content of their struggles and to maintain their enthusiasm at the high level appropriate to great historical tragedy” (1992, p. 148). Here costume is suspect, donned to dissimulate.

Marx’s thoughts on fashion as motor, product, and metaphor of the capitalist system are echoed in the work of the German cultural critic Walter Benjamin (1892–1940). Benjamin analyzed modernity, focusing on how technology and urbanization alter experience, and, specifically, how cultural forms are affected by mechanization, industrialization, and capitalism. According to Benjamin, fashion’s tempo is driven by capitalism. Capitalism needs constant novelty in order to keep sales buoyant. Benjamin named this tempo the “eternal recurrence” of the “new” (2003, p. 179). Simultaneously, Benjamin observed a modern drive toward uniformity and mass reproduction, exemplified by the standardization of women in the song-and-dance revues. Here rows of girls were identically dressed and made up, and they danced in formation. Such cabaret entertainment was extremely popular in Weimar, Germany, and along with fellow critic Siegfried Kracauer, who wrote of such shows as a cultural equivalent to the predictable and mechanistic movements of the Fordist conveyor belt, Benjamin regarded such presentation of women as socially significant. Likewise, a vignette in *The Arcades Project* noted a 1935 fashion craze: women wore initial badges made of metal, pinned to jumpers and coats. The fashion accessory signified both the alienating reduction of self to alphabetic cipher and the loss of privacy in a crowded world. Developing Marx’s notion of commodity fetishism, Benjamin also analyzed fashion as a seducer of living humans into fashion’s dead, inorganic world of materials and gems. Capitalism makes people increasingly thinglike; fashion dramatizes this transformation.

Peter Stallybrass’s essay “Marx’s Coat” develops Marx’s theory of commodity fetishism in relation to the coat as useful object and as commodity or “exchange-value.” He recovers the “use-value” of a coat through an examination of Marx’s frequent pawning of his own overcoat, an event that prevented Marx’s research in the British Library, as he could not gain entry without such a garment testifying to his respectability. Significantly, Marx called the poorest class the *lumpenproletariat*; *lumpen* means cloth rags. As Stallybrass shows, for the poor, even the shirts off their backs had to be exchanged for a few

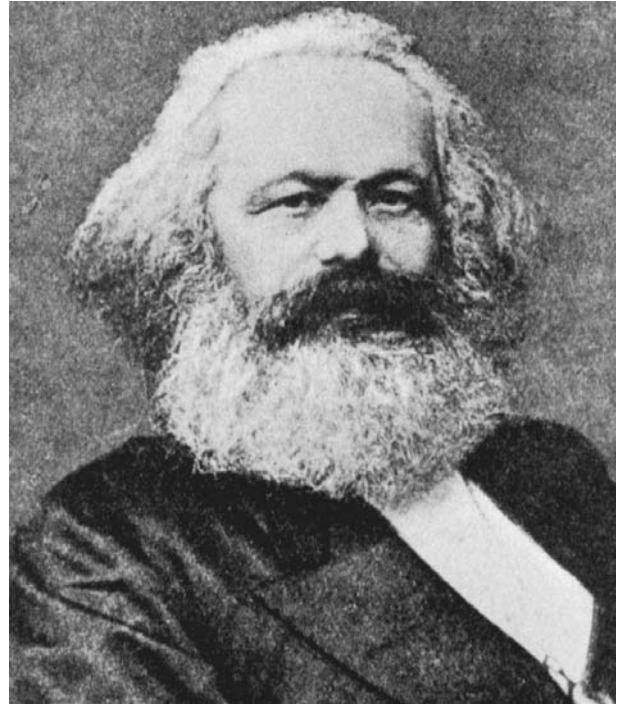

**Karl Marx (1818–1883).** The greatest nineteenth-century critic of capitalism, Karl Marx referred to the “murderous, meaningless caprices of fashion.” Marx considered the ever-changing trends of fashion to be wasteful and, combined with sweat shop-style industrialization, they epitomized for him the culture of capitalism. PUBLIC DOMAIN.

pennies at the pawn shop, however essential for living these shirts were or however sentimental their value. Marx’s attack on a system that made this sort of exchange necessary, notes Stallybrass, is an attempt to stand up for human dignity and memory as it is embodied in material. Indeed, Marx’s materialism can be, in this way, quite concretely linked to questions of cloth material, its mode of production, and its human meaning.

See also **Benjamin, Walter; Politics and Fashion.**

#### BIBLIOGRAPHY

- Benjamin, Walter. *The Arcades Project*. Translated by Howard Eiland and Kevin McLaughlin. Cambridge, Mass.: The Belknap Press, 1999.
- . “Zentralpark.” In *Walter Benjamin, Selected Writings, Vol. 4: 1838–1940*. Translated by Edmund Jephcott, et al. Edited by Howard Eiland and Michael W. Jennings. Cambridge, Mass.: The Belknap Press, 2003, pp. 161–199.
- Marx, Karl. *Capital: A Critique of Political Economy*. Introduction by Ernest Mandel. Translated by Ben Fowkes. Hammondsworth, Middlesex, U.K.: Penguin Books, 1976.
- . “Class Struggles in France.” In *Surveys from Exile*. Edited by David Fernbach. Translated by Paul Jackson. London: Penguin, 1992.

———. “The Eighteenth Brumaire of Louis Bonaparte.” In *Surveys from Exile*. Edited by David Fernbach. Translated by Ben Fowkes. London: Penguin, 1992.

Stallybrass, Peter. “Marx’s Coat.” In *Border Fetishisms: Material Objects in Unstable Spaces*. Edited by Patricia Spyer. New York and London: Routledge, 1998.

*Esther Leslie*

**MASKS** Masks, which function to conceal a person’s face, occur in a variety of forms and can be made from numerous kinds of material, including wood, cloth, and vegetable fiber (the three most common) as well as paint, metal, clay, feathers, beads, bark cloth, and plastic. Masking is an ancient tradition, dating back to the Paleolithic sculpture and cave painting of southwestern Europe (30,000–15,000 B.C.E.) and to rock paintings from the Tassilli area of northern Africa (4,000–2,000 B.C.E.). The Tassilli masks appear very similar to types that are still being worn in West Africa. Additional examples of early masking can be found in rock painting located in parts of Asia and North America.

Masks cover all or part of the face and have been used for many reasons. Some masks function to protect an individual. In the fifteenth and sixteenth centuries, Japanese, European, and Middle Eastern armor included a helmet that safeguarded the head and, in some examples, also frightened an enemy. Numerous other kinds of protection masks exist including gas masks, hockey masks, and space helmets. Yet masks usually imply a type of disguise or transformation in which a person’s identity or appearance is clearly altered. Anonymity is often desired when a person acts in an antisocial or criminal manner and does not wish to be recognized. This would include bank robbers, members of terrorist organizations—including the Ku Klux Klan—and revelers that appear on festive occasions, such as Halloween, Carnival, or Mardi Gras.

In a number of examples, a mask may allow the wearer to transcend his—or in some cases her—ordinary physical nature and take on the identity of another creature, ancestor, or supernatural force. In fact, the majority of masks are associated with ceremonial or ritual activity of a social, religious, economic, or political nature. In a performance context, they often express the otherworldliness of the spirits and make visible what is invisible. Such masks tend to act dynamically when they appear either to a few initiated individuals or to a larger segment of the population—moving, speaking, or gesturing in a dramatic fashion. When considering masks of this category, it is best to employ the more inclusive concept of masquerade, since a masquerade involves more than concealing the face of a person. In most cases, it consists of a total costume functioning within a performance context. The costume may also include objects held or manipulated by the masquerader, which function

as props in the performance or help clarify the character’s nature. The creation of a masquerader can require the specialist talent of many individuals, and the actual performance requires the involvement of additional people, such as dancers, musicians, masquerade attendants, and audience members. The exact function and meaning of every mask is culturally determined. A mask may have different functions through time or it may have two or more functions at any given time. The focus of this entry is on what masks do and what they mean in different sociocultural systems. The structure presented below suggests one way that masks can be organized into functional categories.

### Entertainment and Storytelling

In both Europe and Asia, there is a tradition of covering the face with a mask for theatrical productions. Festivals in ancient Greece used masks, made from linen, cork, or lightweight wood, for both dramas and comedies. For tragedies, masks depicted highborn men and women as well as gods. Animal, bird, and insect masks were only found in comedies. Roman culture continued to utilize theatrical masks and from the sixteenth to the eighteenth centuries, Italian and French touring troupes employed masks or half masks to exaggerate the traits of stock characters in popular theater (*commedia dell’arte*). The improvised performances were never subtle but usually quite bawdy. Satire or social commentary is a feature commonly associated with masking traditions.

A connection between ritual and theater is strongly evident in Asia. Indonesian face masks are used widely for dramatic performances honoring ancestors and telling stories with a moral or historical reference. A spectacular example can be seen with the Barong-Rangda dramas of Bali that depict the age-old conflict between the forces of good and evil. These masks have sacred power and when not in use must be stored in a temple. Rangda, the queen of the witches, represents the forces of evil and both her mask-image and costume are viewed as frightening. She has a long mane of hair with flames protruding from her head and a fierce face with bulging eyes, gaping mouth, huge teeth or tusks, and a long tongue. Around her waist is a white cloth, an important instrument of her magic. Rangda’s opponent in the play, Barong—a defender of humanity, can be presented in a range of animal forms. The most sacred type of Barong is called Barong Ket, a shaggy-haired creature with large eyes, grinning mouth, and a huge curved tail embellished with a red flap and tiny bell. His face is overwhelmed by a huge headdress with large earflaps.

In Japan, *No* developed from rice planting and harvest rituals to theatrical performances that deal with social issues that spotlight past events, supernatural beings, and contemporary concerns. Men wearing lavish costumes and small wooden face masks with serene, neutral expressions perform all the roles. *No* masks, carved from Japanese cypress wood, represent young and old men,

young and old women, deities, and demons. The specific character is brought to life through subtle movements of the actor's body. Actors have a long period of training, wearing their first mask—in a supporting role—as an early teenager. By the time he is sixty years old, an actor is permitted to play a major character that may wear more than one mask during a single performance.

Halloween has evolved from an Anglo-Saxon and Celtic ritual, to become a major American masking event involving both children and adults who wear costumes that depict aspects of popular culture, political issues, cross-dressers, social transgressions, or personal fantasies. In some communities adults have organized elaborate street fairs and parades to celebrate the holiday. For many college towns, Halloween has become a major public event associated with revelry.

### Nature

Among a number of cultures, masquerades are seen as the embodiment of the vital powers of the wilderness and its inhabitants. A major concern of the Baining of New Britain (Papua New Guinea) is the transformation of the products of nature into social products through collective human activity. Baining masks, representing spirits, usually consist of a variety of large bamboo frames covered with beaten tree bark and decorated with leaves, feathers, and elaborate patterns, painted red and black against a white background. All of the designs are named, usually after different types of trees, plants, or creatures of the bush. The mask ensembles refer back to the natural domain and during the dances they mediate between the bush and community. The masks in part derive their importance from the fact that they are made out of bush material that has been transformed by human work into finished products. Although there are many types of masquerade, all can be organized into two broad categories: day dances and night dances. Day dances are associated with females and the gardens while night dances relate to males and the bush; not every village has both. These night masks, consisting of a wide variety of plank and helmet types, are named after products of the bush, especially those that men hunt and gather. The day masks, on the other hand, are usually tall, vertical structures up to forty inches high. The designs on these masks relate to the growth of domesticated plants.

The Kalabari Ijo of the delta area of Nigeria believe they share their environment with water spirits (Owu) who play an important role in providing benefits to the community. Throughout West Africa, spirits of the water are seen as more positive and more helpful than spirits associated with the forest or wilderness. For the Kalabari, wooden masks are used in the ritual cycles that honor these spirits associated with a body of water, usually a creek. Although each water spirit has its own costume, music, and dance, and appears at different points in the festival, they all dance together at the end of the ritual cycle. Water spirit masks, in the form of fish or other

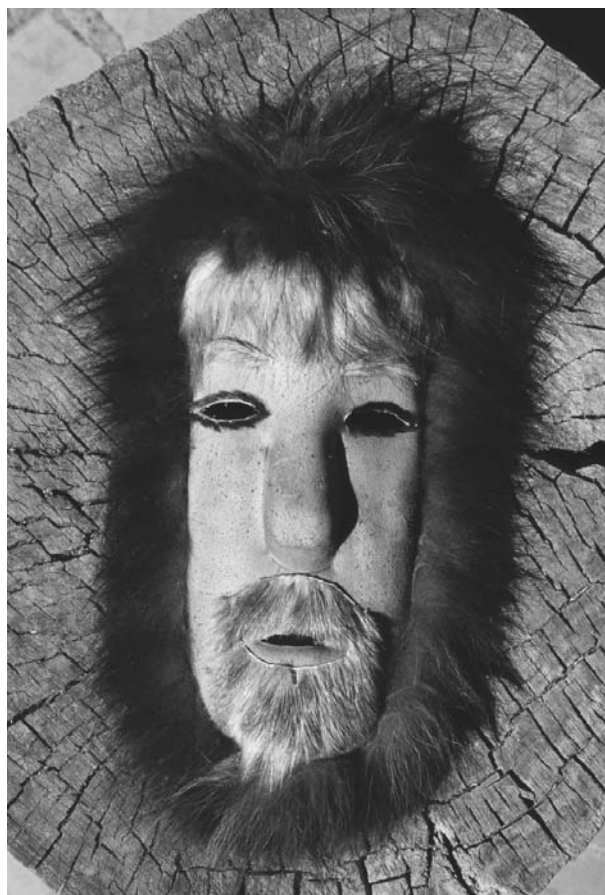

**Traditional Eskimo mask.** Masks are often worn by shamen during dances performed to influence spirits of nature in blessing the tribe with good hunting conditions. © DANNY LEHMAN/CORBIS. REPRODUCED BY PERMISSION.

aquatic creatures and humans, are worn horizontally on the head and are characterized by a swollen forehead, a long nose, and a projecting mouth. The masqueraders also wear a costume made from different layers of cloth.

The masks of the Alaskan Eskimo populations function to provide protection from potentially dangerous nature spirits and to ensure successful hunting. For the Eskimo, animals are not just food products but spiritual beings that must be treated with respect. They believe that all natural forms have a soul (*inua*) that will usually reveal itself to a person in the form of a small, human-like face on the back, breast, or in the eye of a creature. Masks represent supernatural beings who control the forces of nature, the spirits of particular mammals and fish, or natural phenomena such as air bubbles, a particular season, or even the wind; their specific form is based on the dream or trance of a shaman (religious leader who has an extraordinary ability to intercede with the spirits). Masks, normally made from driftwood, are created by shamans or by carvers working under their direction; they are found in a variety of shapes including a basic human





**Japanese Noh mask.** Noh is a form of stage art that combines elements of dance, drama, music, and poetry. It is performed by men wearing lavish costumes and expressive, wooden Noh masks. © REUTERS/CORBIS. REPRODUCED BY PERMISSION.

face, an oval form with some facial features, or abstract forms full of distortions and additive features. Twisted mouths, eyes of different shapes, peg teeth, encircling hoops, feathers, miniature legs, arms, small animal forms representing the shaman's spiritual helpers, sometimes frame the face and project outward into space. Masks are used in dances and elaborate winter ceremonies, which take place in the men's house and the ceremonial center of a village. A mask is usually worn by the shaman or by someone he selects and, in large part, is designed to appease the animals killed and to ensure that they continue to reproduce.

### Healing and Community Well-Being

Among the Bamana of Mali, the powerful Komo association is a high-level institution, under the leadership of blacksmiths. It functions to protect the community against sorcerers and other malicious beings. The Komo horizontal helmet mask is carved and worn by a blacksmith at special secret night ceremonies. The Komo mask is a conglomerate medicinal assemblage that moves swiftly and aggressively like a wild beast. It essentially functions as a wooden support for many different kinds of power substances. Protective amulets and feathers that

symbolize the celestial realm, antelope horns that symbolize the power and mystery of the wilderness, and porcupine quills that symbolize knowledge are added to the Komo mask as they are believed to constitute the necessary ingredients to effectively combat sorcery. Moreover, the surface of the mask is impregnated with kola juice, millet, and chicken blood, all of which contribute to the awesome power and frightening appearance.

The girl's four-day puberty rite of the Apache is more than an initiation ritual as it is significantly concerned with the well-being of the entire community. This ceremony invokes the benevolence of the deity, Changing Woman, to bring good fortune to everyone in the community. On the second night of the puberty ritual, Gan masqueraders, wearing plank headdresses made of slats of yucca or agave stalk and a black cloth hood (originally buckskin), impersonate mountain spirits who bless the area and help protect the community from dangers and disease. Originally the mountain spirits lived with ordinary people, but in order to avoid death, they fled to the mountaintops to seek a world of eternal life. Before departing, the mountain spirits taught the Apache how to conduct the curing ceremonial and how to construct the appropriate costume. The headdresses are painted with black, blue, yellow, and white with patterns that protect the dancer from evil forces. During the curing ceremony, both the Gan spirits and the initiate are able to purify the community and expel illness.

The Society of Faces of the Iroquois (New York and Ontario) use masks in the communal longhouse during the mid-winter ceremonies to drive away disease and to cure those who are sick. Private curing ceremonies can also be performed in the house of a sick person. Once someone is cured by the masks, he is able to join the society. Most masks portray humanlike spirits that reveal themselves to people in dreams or by suddenly appearing in the forest. These medicine masks also participate in seasonal renewal ceremonies held in the spring and fall. At this time they run through the village, shaking rattles, to cleanse the community from all afflictions. The masks are empowered to heal an individual and to protect an entire community from the evil that supernatural powers could inflict upon it.

The carved masks are usually made from basswood, but other soft woods can be used. Ideally, a mask should be carved from a living tree. Only men are permitted to carve and wear the False Face masks. Horsehair, paint, and metal to surround the eyes are applied to the wooden face. Most masks depict capricious forest spirits that have come to serve human beings with their medicine power through gifts of food and burnt tobacco offerings. Corn-husk masks, on the other hand, worn by either men or women, are used in curing ceremonies, which follow those of the wooden masks. Iroquois women create them by sewing together coils of braided husks; they represent vegetation spirits responsible for the renewal of growth from season to season.

### Agricultural Fertility

The Hopi of northern Arizona have established a yearly ceremonial cycle divided into two parts. The first from the winter solstice in December to mid-July is marked by kachina ceremonies. Five major and numerous one-day ceremonies are held during this time. The purpose of a kachina performance is the bringing of clouds and rain but it also includes promoting harmony in the universe in order to ensure health and long life to the Hopi. Kachinas, who are invisible forces that reside in the San Francisco Mountains, are associated with clouds and rainfall. All in all, there are about 250 kachinas, but only 30 are major ones. During the winter, kachinas participate in rituals held in the ceremonial center (kiva). When spring arrives, kachina dances are held in the village plaza. In the intervals between dances, when the main kachinas are resting, clown kachinas enter the plaza and afford comic relief. The cycle ends with the home dance (Niman), a sixteen-day ritual that begins just before the summer solstice. Although any kachina can participate, it is normally performed by a group of Hemis kachinas, characterized by an elaborate wooden tablita (crest form) depicting rainbow, cloud, sun, and phallic images. The tablita surmounts a case mask, usually half of it painted green while the other half is pink. The body of the impersonator is painted black and decorated with light-colored half moon motifs.

The best-known mask type of the Bamana of Mali is the Chi Wara, a graceful and decorative carved antelope, which appears when the fields are being prepared for planting. The primary purpose of the Chi Wara association, also concerned with the training of preadolescent boys, is to encourage cooperation among all members of the community to ensure a successful crop. Always performing together in a male and female pair, the coupling of the antelope masquerades speaks of fertility and agricultural abundance. The antelope imagery of the carved headdresses was inspired by a Bamana belief that recounts the story of a mythical beast (half antelope and half human) that introduced agriculture. The male antelopes are decorated with a mane consisting of rows of openwork zigzag patterns, and gracefully curved horns, while the female antelopes support baby antelopes on their backs and have straight horns. These headdresses are then attached to a wicker cap, which fits over the head of the masker, whose face is obscured by black raffia coils, hanging from the helmet.

### Initiation and Coming of Age

Many societies in different parts of the world institutionalize the physical and social transformation that boys and girls undergo at the time of puberty in order to ritually mark their passage from childhood to adulthood. In the West African country of Sierra Leone, Mende girls begin an initiation process into the female Sande association where they learn traditional songs and dances and are educated about their future roles as wives and mothers. After successfully completing all initiation obliga-



**Antelope masks.** A Bambara man and woman in Mali dance to Chi Wara, a half man, half antelope spirit believed to bring good luck to farmers. © CHARLES & JOSETTE LENARS/CORBIS. REPRODUCED BY PERMISSION.

tions, the girls dress in fine clothing, form a procession, and parade back to town led by Sande members and a masked dancer who represents a water spirit and symbolizes the power of the Sande association. In Africa, the Sande is unique in that it is the only documented association in which women both own masks and perform masquerades. The Sande masked dancer wears a costume of black raffia and a carved helmet-type mask. The masks—characterized by fleshy neck rolls, delicately carved features, a smooth, high forehead, and an elaborate coiffure—is seen as expressing a Mende feminine ideal. The shiny black surface of the mask alludes to the flowing river, the water spirit's home when the Sande association is not in session.

Variations of *mukanda*, a male initiation association, are found in the western Congo and Angola. Here, masks are worn by both initiated novices and senior officials for final initiation celebrations and during the period of seclusion when boys are socialized into men. Taken together the initiation masks symbolize the authority of males, including the ancestors. Among the Yaka people,

one type of *mukanda* mask is associated with elaborate headdresses surmounting a human face which is either naturalistic or, more commonly, a schematic interpretation where the features are abstracted and enlarged. A large and distinctive turned-up nose resembling a beak is frequently found. Lines may be incised into each cheek and refer to tear marks associated with the pain of the initiation. The headdress sometimes presents ribald sexual imagery with didactic and proverbial meaning. Worn by camp leaders these masks are said to protect the fertility of the *mukanda* members and to both demarcate and elucidate gender differences

As part of the puberty ceremony carried out among Sepik River peoples in New Guinea, boys undergo a period of seclusion during which masks depicting bush spirits appear. After appropriate training, the newly initiated boys enter a men's meetinghouse, the political and religious center of the community, and in the open space in front of the meetinghouse, initiation dances are held. Various mask types appear at this time, ranging from face masks to large fiber costumes to which wooden faces can be attached. Leaves and large orange fruits can also be attached to a costume. Most of these masquerades impersonate clan or bush spirits.

Among the Kwakiutl of the northwest coast of America, male initiation rituals take place in large ceremonial houses during the winter months. The most important Kwakiutl initiatory society is *hamatsa*, the cannibal society, which cuts across family and clan ties. After spending time in the forest and being introduced to the spirit world, a young man must be formally reintroduced back into society. This reentry is a four-day public event featuring dancing, singing, and masquerading. Masked dancers of animal and human form represent spirit beings associated with particular kinship groups or with the wilderness. The most theatrical of masks are those capable of transforming into another form. In this case, a single mask will have more than one identity. This feat is accomplished by the dancer who manipulates strings to open the outer mask to reveal another face within. An important component of this event is the appearance of large mythical cannibal bird masks, such as Raven and Crooked Beak of Heaven, who reside in the north end of the world. These enormous masks with a movable mouth are worn on the dancer's forehead at an upward angle. Kwakiutl masks, which have large bulging eyes, heavy curved eyebrows, and flat, rectangular drawn-back lips, are often embellished with broad geometric painted patterns. The most frequently used colors are black and red; blue-green and yellow are also found.

### Social Control and Leadership

Masks from the Dan, a politically noncentralized group in southeastern Liberia, function primarily as agents of social control. In the nineteenth century, these masks provided the only unifying structure in a region of autonomous communities. Dan masks, known as *gle* (spirit),

derive their authority from the possession of supernatural power. For the Dan, a spirit will select a man to be its owner by coming to him in a dream or vision, instructing him to have created a specific style of mask and costume. Stylistically these masks can be divided into two basic types. The first type, called Deangle is an oval face form with recognizably human features, representing a female spirit. These masks portray a gentle, peaceful spirit whose attributes of behavior are seen as feminine. The costume of the Deangle mask normally consists of a conical headdress, a commercially made cloth draped around the shoulders, and a raffia skirt. A second type of mask, Bugle, which represents male forest spirits, is grotesque and enlarged with tubular features and angular cheek planes.

In general, Bugle masks are responsible for important social control functions such as judicial decisions, law enforcement, criminal punishment, fine collection, and military supervision. Although a Deangle mask may begin its life history in an initiation camp or as an entertainment mask, its status can become elevated to that of a more powerful judge mask. Moreover, any Dan mask can function as the powerful great mask, which settles important matters like stopping wars between villages. When a mask assumes greater social control responsibility, its costume will change to reflect a new status and personality.

The Bamilike and Bamun kingdoms of the Cameroon grassfields perform masquerades owned and danced by men's regulatory associations responsible for maintaining social order. The most important regulatory society of the Bamilike is Kwifyon, which serves to support the royal establishment, but also counterbalances the power of the king by playing an important role in government, judicial administration, and policing activities. Grassfields wooden masks depicting human beings are characterized by rounded faces, prominent cheekbones, bulging almond-shaped eyes, and semicircular lateral ears. They exhibit considerable variation in form, ranging from a crest worn on top of the head to helmet forms with carved elaborate headdresses revealing symbols of authority. Attached materials, such as shells, beads, and brass, indicate high status. Animal masks symbolize important attributes of leadership and power, particularly the leopard and elephant.

The Kuba kingdom located in the Democratic Republic of the Congo has developed a masking tradition to function in a leadership context. The three principal royal masks, Mashambo, Ngaddy a mwaash, and Bwom, may dance separately at royal initiation and funeral ceremonies or perform together when portraying the mythological establishment of the Kuba nation. Mashambo, the most important royal mask, represents the legendary ancestor who founded the ruling Kuba dynasty. The mask's structural frame is made of wicker, covered with leopard, and cowrie shells. The second mask (Ngaady a mwaash), which symbolizes the sister-wife of



the legendary ancestor, is a more naturalistic wooden face with slit eyes. It is decorated with an overall pattern of painted striped and triangular motifs, seeds, beads, and shells. The third mask (Bwoom) represents a person of modest means or the nonroyal members of the society symbolically balancing the royal establishment. The Bwoom mask is a wooden helmet decorated with sheets of copper, hide, shells, seeds, and beads. Although the added materials enhance the mask, the carved form itself makes a powerful aesthetic statement.

See also **Carnival Dress; Ceremonial and Festival Costumes; Masquerade and Masked Balls.**

#### BIBLIOGRAPHY

- Cole, Herbert, ed. *I Am Not Myself: The Art of African Masquerade*. Los Angeles: Museum of Cultural History, 1985.
- Colleyn, Jean-Paul, ed. *Bamana: The Art of Existence in Mali*. New York: Museum for African Art, 2001.
- Corbin, George. *Native Arts of North America, Africa, and the South Pacific*. New York: Harper and Row, 1988.
- Fienup-Riordan, Ann. *The Living Tradition of Yup'ik Masks*. Seattle: University of Washington Press, 1996.
- Jonaitis, Aldona, ed. *Chiefly Feasts: The Enduring Kwakiutl Potlatch*. New York: American Museum of Natural History, 1991.
- Mack, John, ed. *Masks: the Art of Expression*. London: British Museum Press, 1994.
- Napier, David. *Masks, Transformation and Paradox*. Berkeley: University of California Press, 1986.
- Perani, Judith, and Fred T. Smith. *The Visual Arts of Africa: Gender, Power, and Life Cycle Rituals*. Upper Saddle River, N.J.: Prentice-Hall, 1998.
- Pernet, Henry. *Ritual Masks: Deceptions and Revelations*. Columbia: University of South Carolina Press, 1992.

Fred T. Smith

**MASQUERADE AND MASKED BALLS** Masquerades and masked balls are linked to the celebration of Carnival and *mardi gras*. Originally part of a cycle of pagan festivities celebrating the advent of the spring planting season, in the Middle Ages, Carnival began after the winter solstice as part of the Feast of Fools, for which the congregation elected abbots and bishops from among the junior clergy who masked and dressed in women's clothes and performed a mock Mass that ended with dancing in the church and streets, and the coronation of an Abbot of Misrule. With the Reformation, Protestant countries banned Carnival, while the Feast of Fools moved into the street. The result was that in Catholic countries, Carnival revelry and masking took over the streets of towns and cities between Twelfth Night and Ash Wednesday, in anticipation of giving up all *carne*—meat and sex—for Lent. Carnival thrived in Paris, Venice, and Rome, among other cities. The last six days of Carnival were called *les jours gras* (fat days) last-

ing from *feudi gras*, the Thursday before Ash Wednesday through the night of *mardi gras*. *Les jours gras* were celebrated with masked balls, obscene dancing, and eating, drinking, and sex. On the morning of Ash Wednesday, this orgiastic explosion ended in a parade of exhausted, masked revelers.

Masquerades also existed in eighteenth-century London, but it is Parisian Carnival and its masked balls in the nineteenth century that have produced the most commentary, gossip, and visual images. Many European and American observers published memoirs describing their experiences at the masked balls in Paris, while lithographs of the masked balls at the opera and at other Parisian theaters and dance halls proliferated during the nineteenth century, producing countless imitations. Indeed, in popular culture masked balls and the French were so closely linked that an early American silent movie (1908) is titled *At the French Ball*—the story, of course, of adultery at a masked ball.

Court theatricals with masks and a ballet were initially introduced at the French and English courts in the seventeenth century. By the early eighteenth century, masquerades and *bals masqués* (the French term for masked balls) were attracting large crowds at the newly opened public dance halls in London and Paris, at the aristocratic balls at the Paris opera (as of 1715), and in private Parisian mansions that welcomed the masked public during Carnival. During the eighteenth century, the masked balls in public dance halls were the height of English fashion, while the French celebration of Carnival was increasingly politicized and used to attack the monarchy. In this world turned upside down, women dressed as men, frequently as soldiers, sailors, or stevedores; men as women; the poor disguised themselves as bishops, lawyers, and aristocrats; and the rich disguised themselves as beggars, peasants, fishmongers, in Oriental masquerade, and *in domino*, the classic Venetian costume of a hooded black cape and mask. Regardless of a person's gender and class, sexual license was tolerated at masked balls so that men and women were free to indulge their sexual proclivities with persons of whatever sex and class they chose. With the French Revolution, Carnival and masking were temporarily banned, while in England such permissiveness died. In 1800 Napoleon reintroduced Carnival, although by 1830 Parisian Carnival was said to be a thing of the past.

Nonetheless, from a mere three authorized public masked balls during Carnival in 1830, by 1831 Parisian Carnival exploded in the aftermath of the July Revolution (1830). The combination of a new revolutionary generation disaffected with the conservative government of the July Monarchy and the spread of romanticism infused new life into Parisian Carnival. The fashion press and the new satirical dailies, benefiting from the introduction of cheap lithographs illustrating the masked balls at the opera and at other theaters. The introduction of gossip columns and cheap newspapers, paid for by advertising

instead of subscription, provided Parisians and readers everywhere a blow-by-blow account of the masked balls during Carnival after 1830. The satirical daily *Le Charivari* coined the catchwords of Carnival, “Down with the Carnival of our ancestors! Hooray for the carnival of romanticism and politics,” and published lithographs by Honore Daumier and Paul Gavarni depicting the Carnival masked balls in all their glory. Hundreds of pamphlets, satires, illustrations, and fashion magazines supplied a running commentary on the pleasures to be found at the Carnival masked balls at their height in the 1830s and 1840s, including the masked balls that took place in the middle of the Revolution of 1848. It is not surprising, then, that although these balls continued until the end of the century, it was this period in the 1830s and 1840s that was mythic and that was depicted in Edouard Manet’s famous painting *Le Bal masqué de l’Opéra* (1873).

What made this Carnival and its masked balls so remarkable was the confluence of political discontent and the emergence of a consumer society that fanned the flames of pleasure and desire. Many of the costumes reflected a rejection of traditional roles and a yearning for the exotic, suggesting a widespread ambivalence about the values of emerging capitalist society and its imposition of middle-class culture and domesticity. The most chic costumes of the moment worn to masked balls in eighteenth-century London were Oriental masquerades, while in nineteenth-century Paris, Spanish dancers, or couples dressed as stevedores were the most fashionable. None of these fashions lasted beyond their moment, although designers in the early twenty-first century have looked at illustrations from the masked balls of nineteenth-century Paris as an inspiration for clothes.

However, what is significant about Parisian masked balls in the nineteenth century are the technological inventions that made the balls fashionable and accessible to an expanding literate public. The introduction of the lithographic process and the rotary press made it possible for newspapers and magazines to print more newspapers with cheap illustrations, while advertising, a new capitalist invention, reduced their cost. The preeminence of Paris fashion, made more accessible through beautifully illustrated fashion magazines and the introduction of department stores and costume warehouses, offered this new consuming public fashionable disguises and cheaper clothes. Serialized novels in newspapers and gossip columns fed the aspirations and desires of increasing populations and an expanding middle class, especially the women, who now had more money to spend and places to spend it, including the masked balls during Carnival. Most of these elements already existed in England in the eighteenth century, when masquerades were the height of fashion. Missing was the French genius for publicity and seduction, which made the special pleasures and intensity of Parisian masked balls legendary and guaranteed their immortality in print and visual culture, both high and low.

See also **Carnival Dress; Ceremonial and Festival Costumes; Masks.**

#### BIBLIOGRAPHY

- Alter, Ann Ilan. “Pursuing Pleasure at the Masked Balls at the Opera during the July Monarchy.” *Laurels: The Magazine of the American Society of the French Legion of Honor* 60, no. 2 (1989): 101–118.
- . “Parisian Women at the Opera Balls.” In *Masquerade and Identities: Essays on Gender, Sexuality and Marginality*. Edited by Efrat Tseëlon. London: Routledge, 2001.
- Burke, Peter. *Popular Culture in Early Modern Europe*. New York: New York University Press, 1978.
- Castle, Terry. *Masquerade and Civilization: The Carnavalesque in Eighteenth-Century English Culture and Fiction*. Stanford, Calif.: Stanford University Press, 1996.
- Cohen, Sarah R. “Masquerade as Mode in the French Fashion Print.” In *The Clothes That Wear Us: Essays on Dressing and Transgressing in Eighteenth-Century Culture*. Edited by Jessica Munns and Penny Richards. Newark: University of Delaware Press, 1999.
- Flaubert, Gustave. *L’Éducation Sentimentale*. Paris: Éditions Garnier, 1984.

Ann Ilan Alter

**MATELASSÉ.** See **Weave, Double.**

**MATERNITY DRESS** Throughout most of history, all over the world, women’s attire has of necessity been designed to adapt to the needs of pregnancy and breast-feeding, which were likely to take up a large percentage of women’s lives between puberty and menopause. Before the industrial revolution, the making of fabric and clothing was labor-intensive enough to preclude the making of garments exclusive to pregnancy.

Thus, in Western Europe since medieval times, regular dress of all classes has been easily adapted for pregnancy. Laced bodices, frequently involving center panels to cover expanding waistlines, were prevalent. Petticoats, separate or integral with bodices, were tied at both sides, equally adaptable. Women appeared not to mind the rising hemline in front that resulted from the use of a normal wardrobe during pregnancy.

Beginning in the sixteenth century, styles became more restrictive. Bodices were reinforced with boning, but they were still most often laced. Writers scolded women for wearing these styles during pregnancy, accusing them of putting vanity above the health of their unborn child. But it is possible to rest the bodice or corset on the pregnant belly without constricting it, and this was probably common. Women did not abandon corsets during pregnancy, at least in public. Women of all classes wore corsets during pregnancy, tilted across their stomachs, aprons worn high to conceal the gap at the bodice’s front.

Some women did contrive garments specifically for pregnancy, as a surviving set of eighteenth-century quilted garments in the collection at Colonial Williamsburg attests, in which a waistcoat expands over the belly to cover the gap in the jacket front. Possibly this sort of individualized contrivance occurred more often, at least among members of the upper class who could afford it, than surviving examples can document.

Privately, fashionable women in the seventeenth and eighteenth centuries could wear loose “wrapping gowns,” popular at-home wear, worn by both sexes. Women of all classes also donned unboned sleeveless bodices, quilted or corded to support the belly and breasts. Working-class women had the added choice of loose, unconstructed jackets called “bed gowns” over a petticoat.

The sack or sacque gown, introduced in the early eighteenth century, can apparently be credited to the marquise de Montespan, mistress of Louis XIV, who strove to conceal her pregnancy to remain longer at court. This was reported at the time and may be credited more than most such anecdotes deserve. Falling loose both front and back, the sacque later became fitted in front, and thus no more suited to pregnancy than other styles.

At the turn of the nineteenth century, high-waisted styles were well suited both to pregnancy and breast-feeding. Not until waists returned to their normal level in the 1830s did pregnancy require more careful wardrobe planning.

By 1830, most dresses hooked in back; center front openings, and a “drop-front” skirt, were still occasionally used, suggesting wear during pregnancy. In the 1840s and 1850s, the “fan pleated” bodice was popular, partly because it was easily adapted. In surviving examples, gathers beginning at the shoulders extend to the waist and are gathered on drawstrings, allowing expansion and access for breast-feeding and gradual tightening as the body returned to pre-partum shape. Other innovations also existed, such as expansion of the gathers found in the era’s ample skirts. Some nineteenth-century maternity garments contain linings intended to lace over the belly, providing support without constricting it, since the period’s more curvilinear corsets were likelier to cause harm than earlier styles. Less constrictive corsets—less boned, or with expandable lacings over the belly—were also available.

Victorian women did not, as popular myth says, stay at home during pregnancy. Fashion magazines, with typical reticence, fail to identify maternity styles, but they can be detected by careful reading: pregnancy corsets are called “abdominal corsets,” and phrases such as “for the young matron,” “for the recently married lady,” reveal maternity styles. An alert modern reader can easily find them, although pregnant figures are not depicted.

The 1860s brought the use of separates to aid pregnant women. For the rest of the nineteenth century, both at-home and fashionable dress offered styles that worked



**Maternity wear.** Fashion designer Liz Lange stands between two mannequins displaying her designs at her store on Madison Avenue, New York, in 2003. More stylish maternity clothes became available in the late twentieth century. AP/WIDE WORLD PHOTOS. REPRODUCED BY PERMISSION.

during pregnancy. Boxy jackets and amply gathered center bodice panels, for example, seen in the 1880s and 1890s, are among the obvious styles to choose.

In the twentieth century, the ready-to-wear industry strove to cater more to women by adapting current fashions to pregnancy. When catalogs finally identify maternity fashions (about 1910), they still refrain from depicting the pregnant form, revealing old discomfort with the issue but suggesting that the styles were the same as others of the time, albeit with specialized construction. Often this meant a series of fasteners at the sides, so that the dress need not be any larger than necessary in the earlier stages of pregnancy.

After World War II, specific maternity styles developed more markedly. Designers made pencil-thin skirts with elastic panels to cover a pregnant belly. Still, the tops often were made unnecessarily full, unlike regular fashions. Typical of postwar maternity fashion were oversized collars and buttons, an infantilizing effect possibly meant to balance the scale of the garment, although one may see in them a condescending attitude to women. Lucille Ball, star of *I Love Lucy*, exemplified the maternity fashions of the early 1950s, and at the time influenced many women during her 1952–1953 televised pregnancy, seen weekly by millions.

In the early 1980s, Diana, Princess of Wales’ two pregnancies influenced maternity styles. Dropped-waist dresses, then in fashion, were well suited to pregnancy and a favorite of Diana’s. Dresses dropping straight from the yoke with no waist at all, one of the styles favored in the



1950s and 1960s, were also worn. Long tunics and sweaters over stretchy leggings became a popular casual choice.

In the 1980s, styles for working pregnant women also emerged as a category of fashion, as garment makers, and would-be mothers, struggled to find styles apt for women in the workplace. Styles based on men's business suits still dominated, suggesting unease with the notion of women in business; pregnancy required even more cover-up. Maternity versions of masculine business suits resulted, with boxier jackets and expanded skirts. Since then, both office wear and maternity wear have developed away from closely copying men's business wear.

The 1990s saw an end to the customary attempt to conceal pregnancy. The emphasis on fit, athletic bodies, and the culture's comfort with revealing the human form, have led to adopting clinging maternity styles in place of centuries of draping and concealment, and even bare-midriff shirts are worn by pregnant women. Feminism and a body-conscious culture have taken maternity fashion in new directions.

See also **Empire Style**.

#### BIBLIOGRAPHY

- Baumgarten, Linda. "Dressing for Pregnancy: A Maternity Gown of 1780–1795." *Dress: The Journal of the Costume Society of America* 23 (1996).
- Hoffert, Sylvia D. *Private Matters: American Attitudes Toward Childbearing and Infant Nurture in the Urban North, 1800–1860* (Women in American History). Urbana: University of Illinois Press, 1989.
- Leavitt, Judith Walzer. *Brought to Bed: Childbearing in America 1750–1950*. Oxford and London: Oxford University Press, 1986.
- Poli, Doretta Davanzo. *Maternity Fashion*. Drama Publishers, 1997.

*Alden O'Brien*

**METALLIC FIBERS.** See **Fibers**.

**MCCARDELL, CLAIRE** Claire McCardell was one of the most influential women's sportswear designers of the twentieth century. Best known for her contributions to the "American look," she was inspired by the active lifestyle of American women. Known for casual sportswear, shirtwaist dresses, and wool jersey sheaths, as well as practical leisure clothing and swimwear, which she liked to refer to as "playclothes," McCardell designed for working women who wanted stylish, well-made clothing in washable fabrics that were easily cared for.

McCardell was born in Frederick, Maryland, in 1905, where she attended Hood College for two years in the mid-1920s before earning a degree in fashion design at the Parsons School of Design in New York City in

1928. In the course of her studies she spent one year in Paris. Working after graduation as a fit model for B. Altman and Company, McCardell later obtained a job as a salesperson and design assistant with Emmet Joyce, an exclusive, made-to-order salon on Fifth Avenue. Within a matter of months, she was lured away by the knitwear manufacturer Sol Pollack to design and oversee his Seventh Avenue cutting room, where she stayed for less than a year. By late 1929 McCardell was working as a design assistant to Robert Turk, an independent designer and dressmaker, who later took her along with him when he was employed as chief designer at Townley Frocks in the early 1930s.

Turk died unexpectedly in a boating accident in 1932, and McCardell was promoted to chief designer at Townley. McCardell remained with Townley throughout her career, with the exception of a brief hiatus in the early 1940s, and eventually became a partner. During the time that Townley's partners restructured their business, McCardell worked at Hattie Carnegie; however, Townley soon rehired her as their head designer.

#### Innovation

While most of McCardell's contemporaries followed the long-standing tradition of copying Paris fashion, McCardell looked instead to the lives of American women for her inspiration. Insisting that "clothes should be useful," McCardell became one of the first designers to successfully translate high-styled, reasonably priced, impeccably cut clothing into the mass-production arena. Proudly American and rebelliously innovative, McCardell (who, as a student in Paris, had admired the work of Vionnet, Chanel, and Madame Grès) turned her back on the expensive, handmade confections of the haute couture and instead promoted American mass production, readily available materials, and the form-follows-function approach to design. Insisting that heavily decorated, padded, and corseted French fashions often sacrificed comfort to style, McCardell designed clean-lined, comfortable clothes that proved such a sacrifice was not only unacceptable; it was also unnecessary.

The retail magnate Stanley Marcus once described McCardell as "the master of the line, never a slave to the sequins ... one of the few truly creative designers this country has ever produced." Shunning shoulder pads, back zippers, boning, and heavily constructed looks, McCardell became known for her self-tailoring, wrap-and-tie styles, backless halters, hook-and-eye closures, coordinated separates, racy bathing suits, and boldly printed, cotton plaid, shirtwaist dresses cut from men's shirting fabrics. Often referred to as "America's most American designer," McCardell's fresh, youthful designs were founded on logic, informed by comfort, and replete with a common sense, entirely undecorated look. As the veteran fashion model Suzy Parker once described them, McCardell's designs were "refreshingly 'unFrench.'" McCardell's first commercial hit came in 1938 with the "Monastic" dress, an



**American Swimwear, 1946.** Models showcase Claire McCardell's "Pantung Loincloth" (left) and Joset Walker's "Hug Me Tights" (right) swimsuits. Crafted to show off the female body, these styles were considered racy during their time. © GENEVIEVE NAYLOR/CORBIS. REPRODUCED BY PERMISSION.

unfitted, waistless shift, cut on the bias, that hung straight from the waist and was belted in any way the wearer chose. The Monastic was so resoundingly popular that it was copied by competitors into the next decade and remained in her own line in updated versions for almost twenty years. Another McCardell success story was "capsule dressing," or four- and five-piece, mix-and-match separates groups in supple wool jersey, cotton, denim, and even

taffeta. These stylish, well-edited groupings offered women a convenient travel wardrobe that sold altogether for about one hundred dollars and could be tucked into a handbag. An avid champion of pants and wool jersey for both day and evening wear, McCardell's forward-looking designs and fabric sensibility provided American women with multiseasonal clothing that was easily cared for, comfortable, and stylish, but never conspicuously chic.





**American designer Clare McCardell, 1940.** With an eye to providing American women with comfortable, casually elegant clothing to match their active lifestyles, McCardell works at her studio in New York City. McCardell's work was essential to defining and establishing American fashion. © BETTMANN/CORBIS. REPRODUCED BY PERMISSION.

### The "American Look"

McCardell's pared-down, casual American style was the hallmark of what came to be hailed as the "American look," the name under which the work of McCardell and several of her like-minded contemporaries, such as Tina Leser and Tom Brigance, was marketed at Lord and Taylor during the late 1930s and early 1940s. During World War II, McCardell's designs earned further credibility, as they reflected an acute awareness of the evolving roles of mid-century American women. Offering sportswear and daywear that were at once appropriate for the office, cocktail hour, and leisure, McCardell eliminated the fuss, decoration, and strict categorization so often encountered in women's apparel of the time. Answering practical needs, McCardell's 1942 blue denim "Popover" dress, which sold for only \$6.95, was made specifically for at-home domestic work or gardening and even included an attached oven mitt. True to her problem-solving approach to fashion design, McCardell used humble fabrics such as cotton calico, denim, jersey, and even synthetics, effectively ennobling everyday materials by way of thoughtful design and deftly executed construction. And while restrained and disciplined, McCardell's work was hardly devoid of details: Her signature, even idiosyncratic, "McCardellisms"

included severe, asymmetrical, wrap necklines, yards-long sashes, spaghetti-string ties, double-needle top stitching, metal hook-and-eye closures, and even studded leather cuffs. With their sleek lines and "no-price look," McCardell's clothes became a mainstay in the wardrobe of college girls, working women, and housewives alike.

Claire McCardell achieved international fame during her lifetime, appearing on the cover of *Time* magazine and authoring a book on her fashion philosophy, *What Shall I Wear?* in 1957. In 1943 she married the architect Irving Drought Harris. McCardell was diagnosed with cancer in 1958, at the height of her success. The disease claimed her life that same year.

Looking at her own life as a starting point for her line, McCardell's casually elegant, pared-down minimalism and lifestyle-driven sportswear of the late 1930s and 1940s helped forge and define what came to be known as the "American look" and heralded the beginning of a new appreciation for American fashion. As fashion historian Valerie Steele points out in *Women of Fashion*, "without McCardell it is simply impossible to imagine a Donna Karan, Calvin Klein or a Marc Jacobs."

See also **Casual Business Dress; Ready-to-Wear; Sportswear.**

### BIBLIOGRAPHY

Kirkland, Sally. "Claire McCardell." In *American Fashion: The Life and Lines of Adrian, Mainbocher, McCardell, Norell, Trigère*. Edited by Sarah Tomerlin Lee for the Fashion Institute of Technology. New York: Quadrangle/New York Times Books, 1975.

McCardell, Claire. *What Shall I Wear?* New York: Simon and Schuster, 1956.

Milbank, Caroline Rennolds. *New York Fashion: The Evolution of American Style*. New York: Abrams, 1989.

Steele, Valerie. *Women of Fashion: Twentieth Century Designers*. New York: Rizzoli International, 1991.

Yohannan, Kohle, and Nancy Nolf. *Claire McCardell: Redefining Modernism*. New York: Harry N. Abrams, 1998.

*Koble Yohannan*

**MCFADDEN, MARY** Born in New York City in 1938, Mary McFadden spent her childhood on a cotton plantation outside Memphis, Tennessee. She moved to Paris to study at the École Lubec from 1955 to 1956 and the Sorbonne from 1956 to 1957, returning to New York to study fashion at the Traphagen School of Design in 1956. McFadden went on to study sociology at Columbia University and the New School for Social Research from 1958 to 1960.

In 1962 McFadden began working as the director of public relations for Dior New York, until 1965 when she married Philip Hariri. He was a diamond merchant, so the marriage meant a move to South Africa, where McFadden worked as a journalist for *Vogue* South Africa and the *Rand Daily Mail*.



As special projects editor for American *Vogue* in 1970, her individual and idiosyncratic style and love of handcrafts made McFadden an influential figure. She initially designed clothes for herself, which were made to her own specifications from fabrics she had found during her extensive travels, creating an eclectic look that combined designer pieces with “ethnic” garments. When *Vogue* featured McFadden’s tunic ensembles, simple shapes showing her characteristic love of color and print, Geraldine Stutz, president of Henri Bendel, bought them for the store. It was possible at that time for designers to launch their careers by creating a tiny collection and selling it to a single store, and this initial success prompted McFadden to start her own designing and manufacturing business in 1973. She formed Mary McFadden Inc. in 1976 and began designing evening gowns in pleated silk using a unique “Marii” technique, resembling that used by Mariano Fortuny, which she patented in 1975. She combined this innovation with elements of hand-painting, quilting, beading, and embroidery, culling ideas and inspiration from diverse ancient and ethnic cultures. Details of the clothes were handcrafted and used passementerie and beaten brass for fastenings. Since they were made with satin-backed polyester and did not crease, these dresses were ideal for her wealthy, much-traveled customers. Her less expensive clothes, produced in the late 1970s, were still noteworthy for their use of embellishment and mix of luxurious fabrics. Later she marketed her designs on QVC, the shopping channel, where she experienced particular success with accessories. She oversaw numerous licenses of her designs for womenswear, sleepwear, footwear, eyewear, neckwear, and home furnishings.

McFadden’s many career accolades include two Coty Awards and induction into the Coty Hall of Fame in 1979. In 2002 she received a Lifetime Achievement Award from Fashion Week of the Americas. She was the first non-Hispanic recipient of this tribute.

Mary McFadden has always designed her clothes to be relatively independent of trends. Her designs are concerned with an eclectic appropriation of the past and decorative elements from other cultures, which she transforms into “wearable art.”

See also **Afrocentric Fashion; Fortuny, Mariano.**

#### BIBLIOGRAPHY

Milbank, Caroline Rennolds. *New York Fashion: The Evolution of American Style*. New York: Harry N. Abrams, Inc., 1989.

Marnie Fogg

**MCQUEEN, ALEXANDER** Born Lee McQueen in the East End of London in 1969, Alexander McQueen was the youngest of six children to a taxi driver and a social history teacher. He left school at the age of sixteen and started an apprenticeship with the Savile Row tailors



“He takes ideas from the past and sabotages them with his cut to make them thoroughly new and in the context of today.... He is like a Peeping Tom in the way he slits and stabs at fabric to explore all the erogenous zones of the body.”

Isabella Blow, quoted in Sarajane Hoare, “God Save McQueen.” *Harper’s Bazaar* 30 (June 1996): 148.

Anderson and Sheppard. From there McQueen moved to the tailors Gieves and Hawkes, the theatrical costumers Bermans and Nathans, the designer Koji Tatsuno in London, and (at age twenty) to Romeo Gigli in Milan. Returning to London in 1990, he sought employment teaching pattern-cutting at Central Saint Martins College of Art and Design; instead, despite his lack of formal fashion training, he was offered a place in the fashion design course as a graduate student. He was awarded the master of arts degree in 1992. After leaving college, McQueen claimed unemployed social security benefits and feared criminal prosecution if caught working for money. He then began designing under the name of Alexander McQueen, continuing to claim benefits as Lee McQueen. His graduate collection was bought in its entirety by the influential stylist Isabella Blow, at that time a *Vogue* fashion editor, who went on to promote and encourage his work over several years.

As Alexander McQueen he immediately started his own label, first showing in autumn-winter 1993. His early collections, such as Nihilism (spring-summer 1994) and Highland Rape (autumn-winter 1995) relied on shock tactics rather than wearability, a strategy that helped him establish a strong identity. With their harsh styling, the designs in these collections explored variations on the themes of abuse and victimization. They frequently featured slashed, stabbed, and torn cloth, as well as McQueen’s brutally sharp style of tailoring. He introduced extraordinary narrative and aesthetic content to his runway shows. Styling, showmanship, and dramatic presentation became as important as the design of the clothes; models walked on water, were drenched in “golden showers” on an ink-flooded catwalk, or were surrounded by rings of flame. The shows were put together on minimal budgets, assisted by models, makeup artists, stylists, and producers prepared to work for nothing. His creative director, Katy England, played an important role in both the development of his aesthetic and the design and styling of his shows. At this stage McQueen began collaborations with designers such as Dai Rees and the jewelers Shaun Leane and Naomi Filmer, whose accessories and jewelry he used in his shows. Besides these activities, he also worked with innovative film, video, and pop producers.

McQueen played up to his bad-boy reputation, opening himself to accusations of misogyny in his Highland Rape collection, which featured apparently bruised and battered models staggering along an apocalyptic, heather-strewn runway, and baring his backside to the buyers at the New York version of his Dante show (autumn-winter 1996). His commercial sense, however, was as sharp as his tailoring, and his antics and anecdotes were always to a purpose, be it to attract press, buyers, or backers. The Dante show in New York, for example, elicited an order from Bergdorf Goodman. From the start McQueen understood the commercial value of shock tactics in the British fashion industry, which had almost no infrastructure despite its reputation for innovation. After he had acquired his first backer, he toned down, while not entirely losing, the outrageous content of the shows. Other important developments for McQueen occurred in 1996. Late in that year he changed his backer to the Japanese corporate giant Onward Kashiyama, one of the world's biggest clothing production houses; it also backed Helmut Lang and Paul Smith. Its subsidiary, Gibo, produced the McQueen line. In October he was appointed designer in chief at Givenchy in Paris, replacing John Galliano, who went to Christian Dior. Also in 1996 McQueen was named the British Designer of the Year—a success he repeated in 1997 and 2001.

McQueen and Galliano thus spearheaded an assault on Paris-based fashion by young British designers in the 1990s, and their iconoclastic imagery and show techniques did much to boost a flagging French business. The appointment to Givenchy brought with it the backing of the conglomerate LVMH (Moët Hennessy Louis Vuitton), which allowed McQueen to continue his uncompromising design style for his own label. While he toned down the rougher edges of his style for Givenchy, in both the Givenchy and McQueen collections he continued to develop themes that had been with him since graduation. Darkly romantic, with a harsh vision of history and politics, McQueen's approach differed from the more straightforwardly romantic output of Galliano or Vivienne Westwood. His inspirations were as likely to be cult films by Stanley Kubrick, Pier Paolo Pasolini, or Alfred Hitchcock; seventeenth-century anatomical plates; or the photographs of Joel-Peter Witkin, as his predecessors in the pantheon of fashion design. His early designs included the low-slung and cleavage-revealing "bumster" trousers; he maintained a fascination with highly structured corsets and tailoring, as well as with historical cut and detailing. However, in the late 1990s the victimized look of his early models gave way to an Amazonian version of female glamour as a form of terror. Growing up with an older sister who was a victim of domestic violence, McQueen has said that as a designer he aimed to create a vision of a woman so powerful that no one would dare to lay a hand on her.

In tandem with his commercial work, McQueen continued to collaborate with photographers such as Nick

Knight and Norbert Schoerner in publishing projects, and to work with those outside the fashion world, such as the artist Sam Taylor-Wood and the musician Björk. Whereas his sharp tailoring was sold in shops, his dramatic, unique showpieces that never went into production were in demand from art galleries and exhibitions across the world.

McQueen sold a controlling share in his business to Gucci in December 2000 and left Givenchy early in 2001, continuing to show under his own name in Paris rather than London. His role as creative director of the company permitted him to retain creative freedom as a designer, while the backing of Gucci—owner of Yves Saint Laurent, Stella McCartney, and Balenciaga—facilitated the transition of his business from a small-scale London label to a global luxury brand. In March 2001 he launched his custom-made menswear line in collaboration with the Savile Row tailors Huntsman. That year McQueen also opened a flagship store in New York and, in 2003, two more in London and Milan. He launched his perfume, Kingdom, in 2003 as well, the same year that the Council of Fashion Designers of America named him International Designer of the Year and that Britain awarded him a CBE (Commander of the British Empire) for his services to the fashion industry.

See also **Fashion Shows; London Fashion.**

#### BIBLIOGRAPHY

- Arnold, Rebecca. *Fashion, Desire, and Anxiety: Image and Morality in the Twentieth Century*. London and New York: I. B. Tauris, 2001.
- Barley, Nick, ed. *Lost and Found: Critical Voices in New British Design*. Basel, Switzerland: Birkhäuser, 1999.
- Evans, Caroline. *Fashion at the Edge: Spectacle, Modernity and Deatbliness*. New Haven, Conn.: Yale University Press, 2003.
- Frankel, Susannah. *Visionaries: Interviews with Fashion Designers*. London: V & A Publications, 2001.
- Tucker, Andrew. *The London Fashion Book*. London: Thames and Hudson, 1998.
- Wilcox, Claire, ed. *Radical Fashion*. London: V & A Publications, 2001.

Caroline Evans

**MEISEL, STEVEN** Born in 1954, Steven Meisel became arguably the most important and prolific fashion photographer of his generation. In a body of work notable for its imaginative range and diversity, he has achieved dominance in both editorial and advertising fashion photography. He is the primary photographer for the American and Italian editions of *Vogue*, where his covers and fashion pages have regularly appeared since the late 1980s, and he has produced some of the most memorable fashion advertising ever created, including campaigns for Versace, Dolce & Gabbana, Prada, Valentino, and Yves Saint Laurent, among a long list of advertising

clients. In fact, when Meisel's work for the fall 2000 Versace advertising campaign was shown at London's prestigious White Cube Gallery, it significantly bridged the gap with fine art photography, a question that had plagued fashion photography since its inception.

As a child Meisel was fascinated with fashion magazines, from which he developed an abiding love of the clothing and photographic styles of the 1960s. As a fifth grader Meisel supposedly went to the studio of fashion photographer Melvin Sokolsky and demanded to meet the famous model Twiggy, and during his high school years he photographed models he saw on the streets of New York, including Loulou de la Falaise and Marisa Berenson. After graduating with a degree in fashion illustration from the Parsons School of Design, he immediately went to work as an illustrator, first for Halston, and then for *Women's Wear Daily* (*WWD*). Since he did not want to stay at *WWD*, he got a camera, taught himself how to take photographs, and took test shots on weekends of various young models and actresses, including Phoebe Cates. Some of these shoots—on which he was responsible for the hairstyles, makeup, clothes, and photography—attracted the attention of editors at *Seventeen* magazine, resulting in work for *Mademoiselle* and, eventually, for *Vogue*. Introduced to *Vogue's* editor-in-chief Alexander Liberman and its fashion editor Grace Mirabella, Meisel was asked to style hair, apply makeup, and take photographs, first for the French and Italian collections, and then for the New York collections.

### Influences

Unlike many fashion photographers who base their work on a signature style, the character of Meisel's work is intriguingly diverse. "Inspiration comes from all over the place," the photographer said. "I'm eager to soak up new information—it can be from the nineteenth century as long as it's new to me. It can come from going to the grocery store or looking at an artist from a million years ago" (Meisel interview, 2003; as are all subsequent quotes). His influences range from 1960s fashion, Los Angeles's architecture, Nan Golden's photography, Alex Katz's paintings, and many types of film, from work by Federico Fellini, Woody Allen, and Michelangelo Antonioni to *They Shoot Horses, Don't They?* and *Blow-Up*, with David Hemmings and Verushka. "My style changes constantly," Meisel started. "Fashion is about change. In order to stay current and excited, I try new and different approaches."

Meisel is also inspired by certain women and has been credited with discovering such supermodels as Iman, Linda Evangelista, and Kristin McMenamy. "My pictures are the result of my fantasies projected onto the girl and of me trying to get the girl into my brain," Meisel said. The photographer also feels he has changed fashion photography by using models of different ethnic types, such as the African Americans Naomi Campbell and Beverly Peele, and older models such as Marianne Faithful, Benedetta Barzini, and Lauren Hutton. "I have

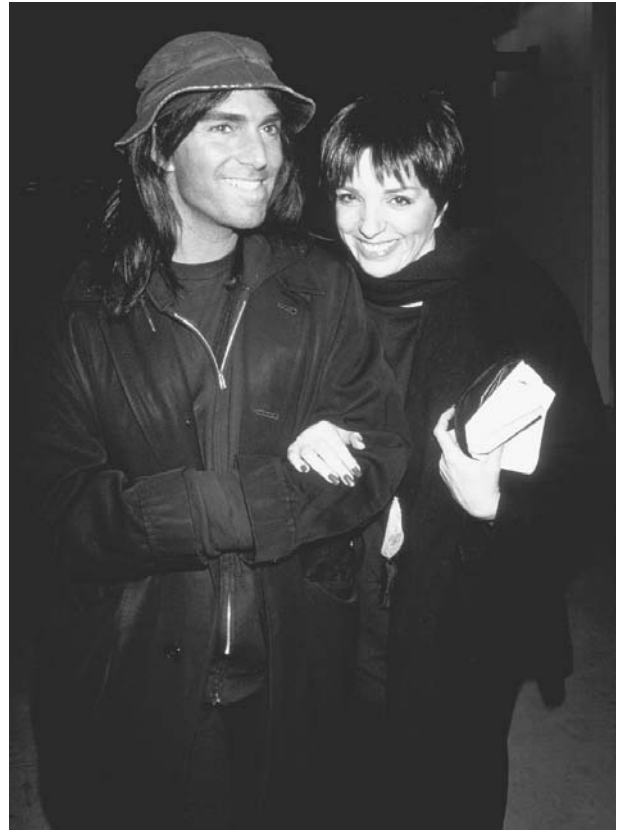

**Steven Meisel with actress Liza Minnelli, 1991.** Celebrated for producing artful and original fashion photography, Meisel has also garnered controversy for his Calvin Klein underwear advertising campaigns and for photographing pop star Madonna's *Sex* book. TIME LIFE PICTURES/GETTY IMAGES. REPRODUCED BY PERMISSION.

the greatest respect for women of all ages. The Barney's ads with Lauren Hutton made a big impact, and I used Benedetta (an Italian beauty who was an internationally-known model in the 1970s) for the Gap campaign." Meisel, like Richard Avedon before him, chooses his models to reflect the zeitgeist. Meisel's work for Calvin Klein, for example, captures the glazed-over disconnect between people of the 1990s, which is why, in the words of one critic, they "feel so subversive." Meisel's Fall 2000 advertising campaign for Versace, which features models Amber Valetta and Georgina Grenville as pill-popping, blue-eye-shadow-wearing Hollywood housewives, affectionately scrutinizes American-style luxury of the late twentieth century.

Controversy seems to swirl around Meisel, to the point that he has himself become a celebrity. "People get interested in me," he said. "In the mid-80s there was a hubbub about me." The fact that he was Madonna's choice to photograph her 1992 book, *Sex*, further fanned the flames of Meisel's notoriety. "I knew Madonna from the clubs in New York. The content was entirely her fantasies ... from her thoughts." Equally shocking to some



were the so-called “kiddie porn” advertisements Meisel created for Calvin Klein, which in the photographer’s words “got so much grief from conservatives. I did a story for *L’Uomo Vogue* using bathing suits on young boys. Calvin came to the studio, saw those pictures and wanted it done like that.” In 1999 Meisel produced an Opium perfume campaign featuring model Sophie Dahl wearing nothing but diamonds and shoes, and in January 2002 he took fashion photography close to the realm of soft porn in a twenty-two-page story for Italian *Vogue*, which featured Russian model Natalia Vodianova.

Steven Meisel’s prodigious talent and extraordinary creativity, coupled with an unerring sense of the zeitgeist, make him the most important fashion photographer to have emerged in the late twentieth century. Like the greatest fashion photographers who have preceded him, Meisel continues to merge his own inventive range of ideas with an extraordinary ability to capture the moment in order to produce fashion photographs of importance and interest.

See also **Fashion Magazines; Fashion Models; Fashion Photography.**

#### BIBLIOGRAPHY

- Klein, Rebecca. “Steven Meisel.” *American Photo* 14 (May/June 2003): 58.
- Lehrman, Karen. “Beyond Fashion? Steven Meisel: From the Collections to the Collectors.” *Art and Auction* 22 (June 2001): 96–104.
- Meisel, Steven. Telephone conversation with author, 5 September 2003.
- Sischy, Ingrid. “The Shattered Bug.” *New York Times Magazine* 150, (19 August 2001 Supplement): 148.
- Spindler, Amy M. “Tracing the Look of Alienation.” *New York Times*, (24 March 1998): Fashion section.

*Nancy Hall-Duncan*

**MICROFIBERS** Microfibers are very fine fibers manufactured by special processes. Developed to exhibit the drape and softness of silk in fabrics, microfibers are less than 0.00004 inches in diameter, about one-tenth the size of silk fibers. Technological improvements have made it possible to produce smaller and smaller fibers, into the range of ultrafine fibers that have diameters of less than 0.000004 inches.

The first microfibers were made by using the traditional melt-spinning process of melting a polymer, such as nylon or polyester, and extruding it through very fine holes. The disadvantage of this direct spinning method was that the filament fibers were so fine they would break during the extrusion process or during subsequent conversion into yarns and fabrics. Consequently, special manufacturing techniques are used. The most common is to spin bicomponent fibers composed of two different polymer types (for example, nylon and polyester). The

bicomponent fiber may have either a citrus or an islands-in-the-sea configuration. The citrus structure has wedge-shaped segments of one polymer held within a star-shaped core of a different polymer. In the islands-in-the-sea configuration, tiny “islands” of one polymer are dispersed in a “sea” of another polymer.

For both structures the bicomponent fiber as spun is thick enough to withstand the processing. After the bicomponent fibers are spun, they are made into yarns and woven or knitted into fabrics. After the fabric is formed, one of the polymer components is dissolved, leaving the other component as microfibers.

Because they are so fine, microfibers are flexible and bend easily, so that fabrics made from them are soft and drapable. In addition, microfiber fabrics are dense, because the small fibers are able to pack closely together. This gives the fabrics a degree of water repellency, since water cannot as easily penetrate the small pores between the fibers. These properties have dictated the types of apparel in which microfibers are used.

Polyester microfiber fabrics are often seen in all-weather coats, sports coats, and soft caps for men and women. Outerwear that has a comfortable feel and also repels moisture has made these microfiber garments popular. Further, the low moisture absorbency of the polyester fibers enhances the water repellency. Nylon microfiber fabrics on the other hand are used for underwear, lingerie, and hosiery. Nylon fibers have the stretch and recovery, as well as strength, often desired for these end uses. The very fine microfibers are soft and comfortable next to the skin, and nylon has higher moisture absorbency than polyester.

The aesthetic and functional advantages of microfibers are well recognized. They are, however, more expensive than their normal-size counterparts. This is because of the more complex manufacturing processes needed to produce them. Making the precursor bicomponent fibers requires specialized equipment, and dissolution of one component after the fabric is constructed is an additional finishing step that must be conducted under carefully controlled conditions.

See also **Nylon; Outerwear; Polyester.**

#### BIBLIOGRAPHY

- Hongu, Tatsuya, and Glyn O. Phillips. *New Fibres*. Chichester, U.K: Ellis Horwood, 1990.

*Billie J. Collier*

### MIDDLE EAST: HISTORY OF ISLAMIC DRESS

Dress in the Islamic world has historically conveyed the wearer’s rank and status, profession, and religious affiliation. Official recognition of loyal service was expressed in gifts of dress fabrics and clothing (in Arabic, *kabilca*; Turkish, *bilat*; Persian, *khalat*) until the late nineteenth century.

Wearing clothing of one's social grouping signified contentment, whereas to be seen publicly in dress worn by a higher class proclaimed dissatisfaction with the prevailing order. Likewise the refusal to don the color or headwear associated with the controlling authority, whether imperial or fraternal, formally demonstrated the withdrawal of allegiance.

The ruling household was presumed to be both arbiter and custodian of "good taste," and any deviant behavior could be used to legitimize rebellion to restore "order." The theologian/jurist constantly reminded the authorities to uphold dress standards to guard against serious social repercussions; thus the 1967 Israeli occupation of Egyptian Sinai was understood by some to be a consequence of Egyptian young women adopting Western fashions. The numerous legal edicts regarding dress (such as the prohibition of cross-dressing, ostentatious female attire, and non-Muslim clothing) were difficult to police, but market regulations (*bisba*), concerning weaving, tailoring, and dyeing practices, were easier to enforce.

The Qur'an contains few details concerning "proper" dress; most guidance is contained in the Hadith (sayings of the prophet Muhammad) literature, an important component of Islamic law. However, it is concerned primarily with certain Muslim rituals, such as the *hajj*, or burial, rather than with everyday wear. Each major grouping and sect of Islam relies on its own Hadith compilation for legal guidance, and over time and in response to regional requirements historic judgements were clarified or superseded. So there is no universal ruling regarding the nature and character of "proper" dress, including female veiling. Maliki law, for example, permitted one finger's width of pure silk for (male) garment trimming, while pure silk outer garments were acceptable in Hanafi circles. All theologians, whether Sunnī or Shīcī, preferred the devout Muslim male to dress austerely in cotton, linen, or wool, and Muslim mystics were known as *sufīs* "wearers of wool." However, it was generally agreed that the prosperity and power of the Islamic state was best demonstrated through ostentatious dress and ceremonial; Muslim philosophers, such as Ibn Khaldun (d. 1406), acknowledged that cultured societies were recognized by their tailored garments, and not by simple Bedouin wraps.

Personal wealth was expressed by ownership of textiles and dress as recorded in the eleventh and twelfth century Cairo Geniza trousseau lists. Certain Muslim festivals were celebrated with gifts of new clothing, while other periods (e.g., the month of Muharram in Shīcī communities) were associated with mourning dress, the color of which depended on regional conventions. Cutting and tailoring of court clothing were undertaken on auspicious days determined by the royal astronomer. In the general belief that spells were more effective when secreted in clothing, the protective formula *bismillab* ("in the name of God...") would be uttered when dressing to deflect any evil. As further protection, many wore items decorated with talismanic designs incorporating Qur'anic verses and



**Medes and Persians at Persepolis, ancient Iran.** Ancient Persian soldiers dressed in *qaba*, a short, close-fitting robe, with trousers or leggings. PHOTO BY JOHN S. MAJOR. REPRODUCED BY PERMISSION.

associated symbols. Clothing of saintly persons, especially those of the prophet Muhammad, was understood to be imbued with *baraka* (divine blessing), and so the master's cloak (*kbirqa*, *burda*) was publicly draped over the initiate's shoulders in Sufi and guild rituals.

Textile processing and production formed the mainstay of the Islamic Middle Eastern economy until the nineteenth century, so, unsurprisingly, Arabic, Persian, and Turkish literature contain numerous references to fabrics and clothing. However, meanings are imprecise and, until recently, many scholars assumed that repetition of a specific garment term over centuries and across regions signified that its meaning and appearance remained unchanged and universal; this assumption has not fostered academic interest in the subject.

Most pictorial evidence is found in post-twelfth-century manuscripts, metalwork, and other artwork, but it rarely relates to family or working life. The advent of photography in the nineteenth century resulted in valuable insights into village and rural dress, but records contain few details of the wearers' ages and social placing, and of garment and fabric structure. Textile finds have rarely been recorded in archaeological reports of excavations, and few museum pieces have been published with full seaming and decorative details.

The basic garment structure was very simple: the loom width formed the main front and back panels, with additional fabric inserts to create extra width and shaping where required, even on many Ottoman and Iranian court robes. Drawstring waists created gathers and unsewn pleats. It was not until the nineteenth century and the introduction of European fashions that shaped armholes, padded and sloping shoulders, darts, and so forth were used in garment structure.

### Umayyad and Abbasid Dress

After Muhammad's death in 632 C.E., Islam spread across North Africa and into Spain, through Syria to southeastern Anatolia and Central Asia, reaching the boundaries of Imperial China and India by around 750. Chroniclers wrote extensively about such conquests, but little on dress matters. Some information is contained in Hadith compilations and in later criticisms of earlier regimes—for example ninth-century disapproval of the trailing robes of perfumed yellow silk worn by the Umayyad caliph Walid II (r. 743–744) as demonstrating a dissolute lifestyle, and the excessively large wardrobe of Hisham (r. 724–743).

With the establishment of the Islamic state, there was no immediate change in dress if only because non-Muslims, then the majority of the population, were required not to dress like Arab Muslims, and it is known that Egypt paid its annual tribute in Coptic garments. The simple wrap (*izar*, *thawb*) of pre-Islamic Arabia, along with a sleeved, collarless *qamis* (shirt) probably came to be recognized as “Muslim” dress for both genders. On top was worn a mantle (*caba*) formed from wide fabric, folded twice into the center along the weft and sewn along one selvage (forming the shoulder), and slit in both folds (armholes). At least six other terms for mantles were in use at this time, indicating that each differed in some way. By the eighth century the turban (*cimama*) of rolled, wound fabric became the acknowledged sign of a Muslim male, and at least sixty-six different methods of winding are mentioned.

As Muhammad disliked the color red and richly patterned fabrics, finding them distracting during prayer, devout Muslim men were advised to avoid such fabrics and colors along with green, the dress of angels. Such recommendations did not apply to Muslim women, but they were enjoined not to parade jewelry, to “cover” (*hijab*, meaning curtain or drape) themselves modestly, and to wear *sirwal* (drawers) of which, the Hadith records, Muhammad approved. Various footwear terms are mentioned, but the camel leather *nacl* sandal, worn by the Prophet, with two straps, one across the foot, the other encircling the large toe, became an enduring favorite and was required men's footwear for *hajj* pilgrims.

In his lifetime Muhammad honored certain individuals by giving an item of personal clothing or fabric length, and this became established court custom (*kbilca*) in the Umayyad period from 661 to 749. An additional honor

was an embroidered or tapestry band (*tiraz*) bearing the caliph's name and other details, sewn or woven near or on the dropped shoulder positioning of the *caba* and of the *jubba*, a long centrally-fastened garment with fabric rectangles joined at right angles to form sleeves. The earliest known *tiraz* fragment in red silk (in the Victoria and Albert Museum, London) records the name of the caliph Marwan I (r. 684–685) or Marwan II (r. 744–750).

Decorative collar and cuffs were features of kingly dress and possibly formed part of the caliphal insignia. The plaster statuary depicting the ruler in Sasanid regal dress (e.g., Khirbat al-Mafjar, Qasr al-Hayr al-Gharbi) perhaps records actual Umayyad caliphal dress, but possibly it merely utilizes a recognizable regal imagery. The Umayyad dynastic color was probably white, worn with a white *cimama* for the Friday prayer, but otherwise, as depicted on coins, the “crown” was similar to the Sasanid crown (*taj*) or a tall sugar-loaf cap (*qalansuwa*).

In this period depictions of women's dress are limited to female entertainers and attendants, with few exceptions. As noted above, *sirwal* were often worn along with a *qamis*, but whether or how these differed from the male garments is unknown. The early eighth century Qusayr Amra murals show half-naked entertainers in checkered skirt wraps, but the ladies in the enthronement composition have long garments with wide necks, and head veils. The Hadith disapproves of artificial tresses, indicating a seventh- and eighth-century fashion, but these entertainers have kiss-curls and ringlets.

A favorite dress fabric at court, especially during the reigns of Sulayman (r. 715–717) and of the Abbasid caliph Harun al-Rashid (r. 786–809), was *washi* from Egypt, Iraq, and Yemen—probably a weft-ikat (tie-dyed) silk because examples, albeit in cotton, have survived. However, the man and woman of fashion avidly sought garment fabrics from across the empire: Egyptian linens, silks from Iraq and the Caucasus, Adenese mantles, Iranian silk and cotton mixtures, and so on, avoiding, if possible, noticeable textural contrast (e.g., cotton and linen) and vivid, contrasting dye shades.

With Iranian support the Abbasid family, proclaiming the right of the Prophet's family to the caliphate, seized control from the Umayyad house in 749. Within decades Spain, North Africa, and then Egypt and southern Syria broke away from direct Abbasid control while hereditary governorships in the eastern regions had virtual independence, provided they paid tribute promptly to the Baghdad court. From 945 if not earlier, the overriding cultural influences in Abbasid court ceremonies and dress were Iranian (the bureaucrats) and also Turkic (military).

As Ibn Khaldun explained, the Abbasid dynastic color was black, commemorating the violent deaths of Muhammad's son-in-law and grandsons. Failure to wear black robes at the twice-weekly audiences demonstrated the wearer's dissatisfaction with the ruler and regime. On



ceremonial duty, the caliph usually wore black, with the Prophet's mantle over his shoulders (signifying his blessing) and carrying other relics associated with Muhammad, or he sometimes wore a monochrome overgarment embroidered in white wool or silk. The *qalansuwa* was still perceived as the "crown," but individual caliphs preferred one model over others.

As court ceremonial became more complex, the main professions of bureaucrat, army officer, and theologian had distinctive dress. The vizier (minister) was recognizable by his double belt, and his colleagues were known as the *ashab al-dararic* (literally, men of the *durraca*) because of their long woollen robes, buttoned neck to chest, probably with long ample sleeves. Army officers (*ashab al-aqbiyya*) wore the shorter, close-fitting *qaba*, probably introduced from Iran by Caliph al-Mansur (r. 754–775), with trousers or leggings. Its exact structure is debatable, but perhaps it was like the tailored eighth- and ninth-century silk robe, patterned with Sasanid motifs from Mochtshevaya Balka, Caucasus. The highest ranks wore black, an honor not permitted to lower ranks, but the caliphal personal guard dressed in patterned silks with gold belts. The military were allowed a form of *qalansuwa*, although by the late twelfth century the highest ranking officers displayed their Turkic origins—and indeed support for Saladin—by donning the *sharbusb*, a fur-trimmed cap with a distinctive triangular central plaque. The theologian on the other hand was identifiable by his voluminous outer robe of black cotton, linen, or wool, decorated with gold-embroidered *tiraz* bands. When giving the Friday sermon, he wore a black turban, but various thirteenth-century *Maqamat al-Hariri* illustrations show him on less formal occasions in a white turban, covered by a shoulder-length black *taylasan* hood.

A lady's ensemble still consisted of *sirwal*, *qamis* under a long robe belted with a sash or cummerbund, and a similarly-colored head covering, all covered by one or more long head- and face-veils for outdoor wear. White was worn by divorced women, and blue and black were reserved for those in mourning. Multi-colored and striped fabrics were best avoided for street wear while bright monochrome colors were associated with female entertainers. Theological criticisms reveal that royal ladies spent wildly on clothing for special occasions, a single robe sometimes costing more than sixteen hundred times a doctor's monthly salary. Unfortunately, specific descriptions of such costly garments are never included.

The *Maqamat al-Hariri* illustrated manuscripts, probably produced in northern Syria or Iraq, contain valuable visual information, and occasionally peasant and working classes are shown in other illustrated works. For the earlier Abbasid period, pictorial evidence is more or less limited to early-twentieth-century archaeological drawings of excavated mural fragments from the palace complexes at Samarra. The painted ceiling of the Capella Palatina (Palermo, Sicily) is more closely related to Fa-

timid (Egypt and North Africa) dress, while wall-paintings in the Xinjiang region (western China) and Lashkar-i Bazar (Afghanistan) depict regional costume styles.

### Dress of the Mamluk Sultanate

With the Mongol capture of Baghdad in 1258, the Abbasid caliph fled to the Mamluk court at Cairo, where he was accorded respect but no power. It has been usual for Western historians to consider the sultanate in two periods: Bahri military rule (c. 1250–c. 1293), and Burji rule (c. 1293–1516). In the Bahri army there were at least five main ethnic groupings, and three divisions, each with distinctive dress, which were fiercely protected, as well as a special uniform for attending the sultan, and another for royal processions. At least six different types of military *qaba* are named, but none can be securely assigned to the various military garments shown in late-thirteenth-century depictions. The *sharbusb* and the *sarajuq*, favorite military headgear until the late thirteenth century, were replaced by the *kalawta* or small fabric cap, sometimes costing almost two months of a doctor's salary, worn with or without a turban cloth. Army and court officers were allowed to display their own blazon (rank) on their belongings, whether shoes, pen cases, or servants' clothing; several, made of appliqué felt, have survived (for instance, those in the Textile Museum, Washington, D.C.).

As the Abbasid caliph was still theoretically the head of Muslim Sunnis, black robes and head coverings were retained as "official" theological dress although Sultan Barquq, tiring of it in 1396 and 1397, ordered the wearing of colored woollen outer garments. Highest-ranking *qadis* (judges) wore the *dilq*, while other magistrates had the *farajiyya*, a garment term in use since 1031; the precise characteristics of either robe are not known. That said, it is evident that there were regional differences, though undefined, as provincial theologians were recognized by their dress, perhaps in the manner of today's foreign tourists visiting another country.

Certain sultans had highly individual fashion tastes, such as al-Nasir Nasir al-Din Muhammad (r. 1294–1295; 1299–1308; 1309–1340), of Mongol parentage, who shocked court circles by wearing Arab bedouin dress. To proclaim the legality of Mamluk authority, the sultan was invested with Abbasid black by the caliph, but generally for court audiences he wore military dress, acknowledging his debt to his fellow Mamluk officers. The *kbilca* or system of honorific garments, described by al-Maqrizi, offers an insight into Mamluk court complexities. Highest-ranking commanders were awarded, among other things, garments of red and yellow *Rumi* (possibly Anatolian) satin, lined with squirrel and trimmed with beaver, with a gold belt and *kalawta* clasps. A white silk *fawqani* robe, woven with gold thread and decorated with silk embroidery, squirrel, and beaver was given to chief viziers while less-costly fabrics of other colors, only hemmed in beaver, were presented to lower-ranking bureaucrats. Such *kbilca* was presented to mark a new appointment, an individual's

arrival and departure from court, the successful conclusion of an architectural project or medical treatment, and similar occasions.

In 1371 and 1372 the sultan ordered members of the prophet Muhammad's family, men and women, to wear a piece of green fabric in public so that due respect could be paid to them. From then on, the leaf-green color, obtained by dyeing first in blue then yellow (thus more expensive than single-dyed fabrics), was formally restricted in Sunnī circles to this grouping. In Mamluk society a bright red worn in public denoted prostitutes, although elsewhere in the Islamic Middle East it was the ceremonial color for the highest-ranking Mongol ladies, and for bridal apparel.

By this time tailored garments were the norm, formed from ten or more shaped units sewn together, as seen in garment fragments in museum collections; regrettably none has been published adequately. Many "Mamluk" dress-weight fabrics have patterns based on foliated teardrop motifs, sometimes edged with Arabic inscriptions blessing the wearer, or lobed rosette shapes surrounded by running animals.

### Dress in the Ottoman Empire

From a small Anatolian principality, the Ottoman family quickly extended authority into most of Anatolia and the Balkans. In 1453 the court moved for the last time to Constantinople (Istanbul), continuing its territorial expansion into central Europe, Egypt and North Africa, the Arabian Peninsula, and western Iran.

Within the Topkapi Saray Museum (Istanbul) collections, there are more than two thousand dress items associated with the Ottoman sultans and their household; few are linked with the royal ladies and children. This source is augmented by numerous manuscript and album paintings, and other items.

Even the sultan's robes were essentially simple in construction, with shaping achieved through joining inserts to the main front and back panels. The central fastening of thread buttons with fabric loops was accentuated by horizontal lines of *chaprast* braiding, the number of rows denoting the wearer's higher status. The typical ceremonial garment, fashionable from the mid-fifteenth century to the mid-sixteenth century, was the ankle-length, elbow-length sleeved *kaftan* worn over another sleeved garment, collarless shirt, and trousers; a calf-length version was also available. A similarly tailored robe but with wide sleeves tapering sharply to a buttoned wrist-cuff was the *dolaman*, a seventeenth-century style. Over these garments, the sultan and high-ranking officials wore a long, ample mantle (*kapaniche*) with a fur-covered, shoulder-width, and shoulder-length square collar flap; for the sultan's investiture mantle, the fur was black fox, while the grand vizier, chief eunuch, and *bostanci bashi* (commander of personal guard) usually had sable. Sleeves were often extra long and worn loose to al-

low lower ranks to kiss the edge. The arm had access through a slit at the elbow or shoulder-sleeve seam. High office was also shown by excessively tall or wide headwear in various shapes, made of padded fine muslin cotton over a balsa-wood form. Breeches with drawstring waists were generously shaped, presumably to allow extra padded linings for winter wear.

There was no noticeable difference between the Ottoman ceremonial garments of the chief bureaucrat and army commander, but there were various distinct regimental uniforms, which became more ornate and less functional over the centuries. The *bostanci* was recognizable in his red, calf-length, long-sleeved outer garment worn with either a red felt cap, drooping over the right ear, or a tall, brown conical cap (perhaps denoting rank). The ceremonial archer *solak* corps wore tight-fitting *shalvar* (trousers) or hose with ankle boots, over which was worn a filmy underskirt and an elaborately patterned sleeved outer garment; an asymmetrical conical headdress with a wide gold headband completed the ensemble. The *peyk* troop of court messengers had a distinctive rounded "helmet" of gilded and incised copper, while the other Janissary regiments demonstrated their association with the Bektashi Sufi order by wearing the *keche*, a white felt "tube" rising some twelve inches from a stiff gold-embroidered band, then falling down the back; it symbolized the garment sleeve worn by the order's founder.

Muslim theologians continued to wear ample outer robes, the *cube* (in Arabic, *jubba*), sweeping the floor and buttoned from the waist, with very wide sleeves. The chief theologian was permitted a sable lining, but urban mullahs were restricted to ermine. In early-eighteenth-century *Sur-name* illustrated manuscripts, lower-ranking jurists are identifiable by their conical "lamp-shade" turbans, but important theologians wore the *wrf*, an enormous spherically shaped rolled turban, white in color, while from the 1590s the *nakib ul-eshrarf* (in Arabic, *naqib al-ashraf*), leader of the prophet Muhammad's descendants, had his in green like his outer robe. Thereafter, Europeans wearing green risked physical attack. Also depicted in various manuscripts are various Sufi (mystic) orders, whose garments and, especially, headgear had specific symbolic connotations according to the order.

There were four main grades of court honorific garments (in Turkish, *bilat*), costing the treasury each year half of what was spent on clothing the ninety-nine Janissary regiments: "most excellent," "belted," "variegated," and "plain." As the terms imply, the difference lay in fabric quality, fur lining or trimming, coloring, and number of items offered. Presentations were also made to provincial and regional governors and to visiting foreign delegates.

Status through dress was also found in the harem, conveyed in the type of fur trimming and lining, and the richness of the bejeweled "marital" belt. European reports regarding female private dress probably relate to

entertainers and women in similar occupations, and to non-Muslim women, as access into the harem by a non-Muslim male was strictly curtailed. Similar constraints applied to Ottoman court painters before around 1710, so it is unclear how accurate these dress representations are. Even with the detailed album paintings of Levni (flourished 1710–1720s), there is little indication of fabric texture and seaming. The late-sixteenth-century street clothing was a long-sleeved, voluminous *ferace* (in Arabic, *farajiyya*) with its long *yaka* back-collar and two-piece *mabrama* face covering, worn with a black oblong horsehair *peche* over the eyes. This garment covered various robes, including underdrawers, ample trousers, and a fine chemise. The main visual difference between female and male attire was not the direction of fastening as in later European dress, but the revealing necklines of women's dress. Various headdresses are depicted, but it is unclear whether these were exclusive to court ladies and whether they indicated ranking. One had a tall, waisted cylindrical form, similar to that worn by fourteenth-century Mongol princesses in Iran and Mamluk ladies in Cairo. Another two frequently illustrated were a small cap with an oval metal plate placed like an angled mirror, and a truncated conical form, sometimes four inches high covered with luxurious fabric.

The choice of fabrics was staggering. Fine wools were manufactured domestically along with choice water-marked silk-mohair mixtures and printed cottons, often used for linings. Sericulture had been in full operation in Anatolia since 1500, producing superb fabrics, often with large pattern repeats highlighted in woven gold and silver thread. As yet, the fabrics manufactured elsewhere in Ottoman territories—for example the Balkans, North Africa, Syria, and Iraq—cannot be securely identified, and there are no detailed descriptions of regional dress outside eastern Europe until the late eighteenth century. The favorite sixteenth-century patterns, often in four or more colors, were based on geometric compositions, meanders, and ogival lattices, formed by or infilled with stemmed flowers, such as the carnation, rose, and tulip, perhaps reflecting the contemporary court interest in gardens; inclusion of figural representations probably denotes non-Ottoman manufacture. Plague outbreaks in the eighteenth century with subsequent loss of skilled weavers perhaps led to the increased use of embroidery and small pattern motifs carried in stripes, as in contemporary French silks.

### Dress in Safavid Iran

Ismail of the Safavid family, relying on the support of some ten tribal clans (*qizilbash*), assumed control of Iran, eastern Turkey, the Caucasus, and present-day Afghanistan, sweeping aside the remnants of Timurid and other regimes. Although the majority of Iranian Muslims were then Sunnī in belief, Ismail ordered that the state religion be henceforth Shīcī Islam of the Ithna Ashari branch, which held that the twelfth descendant (Imam

of Muhammad would return to prepare the community for the day of reckoning. Accordingly early Safavid shahs required their supporters, especially the *qizilbash* (Turkish for “red head”) to wear a distinctive bloodred cap (*taj*) with twelve vertical padded folds ending in a baton-like finial, usually wound with a white turban cloth, symbolizing devotion to twelve Imams and willingness to die for the Safavid cause.

The typical early Safavid court garment retained the simple structure worn in fifteenth-century Iran under a similarly structured outer robe with loose hanging sleeves; both had horizontal chest braiding for fastening. By the 1570s, it was fashionable to don a heavier outer garment, again simply tailored but with the front left panel extended to fasten diagonally, with three or four fabric ties, under the right arm. Neither style was apparently the exclusive prerogative of any office or rank, as probably court and military officers carried identifying wands of office. As the *qizilbash* lost position to Caucasian Georgian mercenaries during the early seventeenth century, so the court turned to Georgian-styled garments with a more fitted line, still achieved by fabric insertion rather than by darts and pleats, accentuating the waist and hips with a calf-length, bell-shaped skirt and central fastening. Likewise, the *taj* was replaced by a fur-trimmed cap with a deep, upturned rim, or by various flamboyant turban forms.

As in the Ottoman court there was a rich variety of silks and velvets, many incorporating metal threads creating a shimmering background for twill weave patterns of isolated floral sprays. Unlike their Sunnī counterparts, Shīcī theologians were not overly concerned with the presence of figural representations on textiles, so motifs of people, animals, and birds were often incorporated into the pattern. Tailored within the palace, the honorific *khalat* garments were graded, according to a court administrator, on the percentage of gold used in silver-gilt metal thread. However, such rich clothing was set aside for black or dark garments during the Muslim month of Muharram, to commemorate the tragic death of the Prophet's grandson, Husain (Third Imam in Shīcī belief).

Examples of mid-seventeenth-century garment styling were described and drawn by Engelbert Kaempfer, John Chardin, and other European visitors, but without precise details of profession and status, and the pictorial accuracy of women's dress is questionable, as access would have been limited to Christian, Jewish, and Zoroastrian females. Iranian album paintings of the mid-seventeenth century depict languidly posed ladies, their heads covered by various patterned and shaped kerchiefs, and the whiteness of their faces emphasized by double strands of pearls draped over the head and under the chin. Their robes are narrow-fitting, full length, and sleeved, with fitted trousers patterned in diagonal stripes, whereas the dancing girls with their multi-plaits shown in contemporary “palace” paintings (e.g., Chihil Sutun,



Isfahan) wear hip-length, sleeved tunics and jackets over bell-shaped, calf-length drawstring skirts.

### Early Ottoman and Iranian Dress

Both the nineteenth-century Ottoman sultanate and the Qajar regime in Iran from 1775 to 1924 decided that military reorganization and reequipment on European lines were vital to counter European and Russian expansionist policies. Theological antipathy was immediate, proclaiming that Islam was being betrayed, and that the wearing of European-styled uniforms signified nothing less than the victory of Christianity; a peaked army cap prohibited proper prostration required in Muslim prayer ritual, while ornate frogging on Austrian-styled military jackets signified belief in the crucified Christ. Both regimes resorted to drastic measures to achieve military reequipment, and then initiated other dress reforms alongside major changes in criminal and civic law, education, and religious endowment management.

The 1839 Gulhane edict removed legal and social differentials between Ottoman Muslim and non-Muslim subjects, including sumptuary legislation relating to non-Muslims. Thirteen years earlier, all adult males, except theologians, had been ordered to wear clothing based on European styling: straight trousers, collared shirts, cravats, and the fez, instead of multicolored long, loose silk robes and turbans. Women were not included, but by the mid-nineteenth century Ottoman ladies of status were eagerly ordering copies of the fashions worn by visiting European ladies.

After World War I Mustafa Kemal “Ataturk” undertook further dress reforms as an integral part of his modernization programs, secularizing the new Turkish Republic and linking it politically with Europe rather than the Middle East. Viewing the fez as the symbol of allegiance to Ottoman values, he ordered the wearing of brimmed hats and Western-styled suits for men, with harsh penalties for noncompliance. Once again women’s clothing was not included; however, salaries were not paid to female government and public employees (for example, teachers, nurses, lawyers, and clerks) unless they dressed in European style and abandoned any face or head veiling.

In nineteenth-century Iran, similar policies were followed by the Qajar shahs. Fath Ali Shah (r. 1797–1834) had introduced a new type of *kulab* headgear of astrakhan lamb in an obliquely-cut conical form, eighteen inches high, and a close-fitting, narrow-sleeved, full-length garment designed to accentuate his height and slender form, which was worn with a dazzling array of jewelry. However, by the late 1840s, the shah’s ceremonial dress was military in style with straight European trousers and shoes and a long buttoned jacket with high “mandarin” collar, embellished with gold frogging including epaulettes. Court officials followed suit. A fur-trimmed open over-jacket of Kirman wool and white gloves completed the outfit.

Court ladies posed for oil paintings in richly patterned, full-length, wide “culottes” (*zir-jamah*), and a fine, filmy sleeved *pirahan* undershirt often slit vertically over each breast (symbolizing fecundity). Over this a short, hip-length jacket (*chapkan, kurdi*), richly patterned, was worn. All this finery was concealed outdoors by a voluminous full-length dark-colored head veil (*chador*) and a fine, waist-length, white cotton or silk face veil (*ruband*). A radical change resulted from the shah’s state visit to Europe in 1873. Seeing the calf-length ballerina skirts and white stockings of the Paris opera chorus, he ordered similar garments for his *anderun* (harem) which, over the years, became markedly shorter, about twelve inches.

In 1924 the military commander Reza Khan (d. 1941) took control and listened sympathetically to Iranian intellectuals, increasingly questioning the relevance of women’s veiling and of social discrimination. Theological hostility erupted with the official abolition of the veil in Afghanistan in 1928, and was fanned in December that year by Reza Shah’s Uniform Dress Law, which required all Iranian men, including nomadic communities but excluding licensed theologians, to wear Western suits, shirts, ties, and brimmed hats or the peaked Pahlavi *kulab*, similar to the French Foreign Legion’s *kepi*. In 1934 female university students and teachers were ordered to wear hats, and by August 1935 women had been unveiled for renewal of identity documents. The Iranian queen appeared in public unveiled in early 1936, and in February of that year the *chador*, the *ruband*, and *pichab* (in Turkish, *peche*) were officially banned.

### Rural and Tribal Dress

Before the 1930s, some 55 percent of the population throughout the Middle East were ruralist, and a further 25 percent were pastoralists (“nomads”), but centralized government, land legislation, economic development, and ecological changes resulted in massive migration from the land to the cities; in Iran and Turkey less than 5 percent lead a “nomadic” life in the early 2000s. Generally speaking, nineteenth- and early-twentieth-century European and Russian studies of nonurban communities were subjective, romanticizing the societies as “unchanging” and “unpolluted,” although knowledge of nonurban and ethnic dress (such as Iranian Kurdish or Bakhtiari) before photography was negligible. Since the 1970s, the anthropological approach has resulted in markedly more objectivity.

Generally, after the 1930s, legislation required men to wear Western dress except during communal celebrations, but occasionally a “national” or “community” emblem was adopted, such as the distinctive felt cap of the Qashqaci (Iran) tribal subclan, introduced in 1941, or the Palestinian *kufiyya* headdress. Most married women over the age of forty continue the dress conventions of their mothers while adopting the required outer wraps for town visits but, as Shelagh Weir concludes, styles and fashions within the community are constantly changing,

albeit less overtly than in the West. The variety of garment structures and dress conventions are as numerous as the clans and ethnic groups within each region.

See also **Islamic Dress, Contemporary; Religion and Dress.**

#### BIBLIOGRAPHY

- Ahsan, Muhammad M. *Social Life under the Abbasids, 170–289 A.H.*, 786–902 A.D. London: Longman, 1979.
- Almegro, Martin, et al. *Qusayr Amra*. Madrid: Instituto Hispano-Arabe de Cultura, 1975. Good photographs.
- Atil, Esin. *Levni and the Surname: The Story of an Eighteenth-Century Ottoman Festival*. Istanbul: Kocbank, 1999. Excellent illustrations with detailed identification of Ottoman court officials, with good bibliography.
- Baker, Patricia L. "The Fez in Turkey: A Symbol of Modernization?" *Costume* (Journal of Costume Society, London) 20 (1986): 72–84.
- . *Islamic Textiles*. London: British Museum Press, 1995. Useful survey and bibliography.
- . "Politics of Dress: The Dress Reform Laws of 1920/30s Iran." In *Languages of Dress in the Middle East*. Edited by Nancy Lindisfarne-Tapper and Bruce Ingham. London: Curzon, 1997. Based on British government Foreign Office records.
- Baker, Patricia L., et al. *Silks for the Sultans: Ottoman Imperial Garments from Topkapi Palace*. Istanbul: Ertug and Kocabiyik, 1996. Superb photographs with three useful essays.
- Bier, Carol, ed. *Woven from the Soul, Spun from the Heart*. Washington D.C.: The Textile Museum, 1987. Excellent textile survey.
- Chardin, John. *Travels in Persia, 1673–1677*. Reprint, Toronto: Dover, 1988. Informative eyewitness report.
- "Clothing: XV, XVIII, XX–XXVI." *Encyclopaedia Iranica*. Costa Mesa: Mazda Publishers, 1992. Costume survey of ethnic groups in Iran, with useful bibliographies.
- Dozy, Reinhart Pieter Anne. *Dictionnaire détaillé des noms des vêtements chez les arabes*. Amsterdam: Jean Muller, 1845. Reprint, Beirut: Librairie du Liban, 1969. Needs revision but shows wealth of terminology.
- Golombek, L., and Veronika Gervers. "Tiraz Fabrics in the Royal Ontario Museum." In *Studies in Textile History*. Edited by Veronika Gervers. Toronto: Royal Ontario Museum, 1977. Thorough specialist survey.
- Graham-Brown, Sarah. *Images of Women*. London: Quartet, 1988. Excellent study of nineteenth- and twentieth-century photographic images across Middle East.
- Haldane, Duncan. *Mamluk Painting*. Warminster, U.K.: Aris and Phillips, 1978. Best available study of Mamluk manuscript painting.
- Levy, Reuben. "Notes on Costumes from Arabic Sources." *Journal of Royal Asiatic Society (of Great Britain and Ireland)* (1935): 319–338.
- , trans. *The Macalim al-Qurba fi abkam al-bisba ... ibn al-Ukhuwwa*. London: Cambridge University Press, 1938. Early fourteenth-century Egyptian *hisba* regulations.
- , trans. and ed. *The Macalim al-Qurba fi abkam al-bisba ... ibn al-Ukhuwwa*. London: Cambridge University Press, 1938.
- Lindisfarne-Tapper, Nancy, and Bruce Ingham, eds. *Languages of Dress in the Middle East*. London: Curzon, 1997. Articles concerning Caucasus, Iran, Turkey, and Arabia with useful bibliographies.
- Mayer, Leo. *Mamluk Costume: A Survey*. Geneva: Albert Kundig, 1952. Based on literary accounts.
- Rosenthal, F., and N. J. Dawood, trans. and eds. [*Ibn Khaldun*] *The Muqaddimah*. London: Routledge and Kegan Paul, 1978.
- Rugh, Andrea B. *Reveal and Conceal: Dress in Contemporary Egypt*. Syracuse, N.Y.: Syracuse University Press, 1986. Informative study of late-twentieth-century town, village, and tribal dress styles.
- Scarce, Jennifer. *Women's Costume of the Near and Middle East*. London: Unwin Hyman, 1987. Contains some drawings of garment structure.
- Serjeant, Robert Betram. *Islamic Textiles: Material for a History up to the Mongol Conquest*. Beirut: Librairie du Liban, 1972. Informative literary extracts on textiles and garments, but confusing arrangement.
- Sims, Eleanor. *Peerless Images: Persian Figural Painting and Its Sources*. New Haven, Conn.: Yale University Press, 2002. Contains many color illustrations, by a leading authority.
- Spring, Christopher, and Julie Hudson. *North African Textiles*. London: British Museum Press, 1995. Textile-oriented but with dress information.
- Stillman, Yedida K., and Nancy Micklewright. "Costume in the Middle East." *Middle East Studies Association Bulletin* 26, no. 1 (July 1992): 13–38. Informative survey of modern scholastic approaches.
- Weir, Shelagh. *Palestinian Costume*. London: British Museum Publications, 1989. Excellent study.

Patricia L. Baker

**MILITARY STYLE** "Uniforms are the sportswear of the twentieth century," Diana Vreeland said once. Strolling through the streets of any cities in the world, one may add that military dress will be an important part of the twentieth-first-century look as well.

Teenagers in cargo pants, men in flight jackets and hooded parkas, and women in safari jackets and sailor pants are common sights on the everyday scene. Fashion runways have featured seasonal flurries of camouflage: print chiffon evening gowns, multipocket vests in bright satin, white leather cinched trench coats, and armies of military cashmere greatcoats with gilded buttons where the initials of famous fashion designers and the logos of powerful brands have taken the place of the insignia of royal families, dictators, and military empires. In the distant aftermath of the great wars, as real soldiers begin to look more and more like civilians—consider the Hollywood icon of the American soldier in plain khaki shirt, tie, and pants—"the imitation of the military uniform has triumphed over the original prototype." This was the comment of Holly Brubach in the *New York Times* on the decision of the American Navy to eliminate the bell-bottomed sailor

trousers just when the fashion designers and the club kids were eager to wear them again.

The formal and technological evolution of uniforms lies at the origin of modern dress; standard military issue consists of a system of industrially produced garments in different sizes and qualities, which change according to social and weather conditions, and communicate belonging or rejection values. We may say that military uniforms are the first ready-to-wear garments, with standardized sizes and proportions to adapt to men and women with different physiques.

In a continuous process of osmosis, military uniforms and civilian dress have influenced each other over the years. An early documented case of this is, after the French Revolution, when the leg-wear of the *sans-culottes*, in revolt against the monarchy, became the model for the practical, clinging trousers worn by Napoleon and his army. The same thing happens with the new fashions of the century: the practicality of civilian clothing is continuously incorporated into military uniforms. And the garments perfected and idealized in military iconography make a triumphant return in everyday civilian dress.

The hunting dress of English country gentlemen—the Norfolk suit—is the prototype for combat gear, the fatigue jacket with deep convenient pockets and a reversible collar. The khaki color—from the Persian word *khak*, meaning dust, earth or mud—of uniforms all over the world, was borrowed from the personal wardrobe of Indian soldiers who dyed their clothing with natural pigments to disguise dirt. Perhaps the most telling of all examples is the continuous and repeated passage of the trench coat from the military to the civil sphere. Created in England, probably by the manufacturer Burberry as a garment for shepherds, farmers, and country gentlemen for protection from rain and wind, this coat became such a common feature among soldiers in the rainy trenches during World War I that it took the name “trench coat” and became a standard garment in the uniforms of many armies around the world. The practicality of this belted raincoat in certain weather conditions justified its utilization even before it became a part of the uniform. Then, between the two world wars, the trench coat returned to everyday closets and became the uniform of adventurers, spies, and rebels without a country, perfectly worn by Humphrey Bogart in *Casablanca* (1942). After being worn again by generals and colonels during World War II, the trench coat returned as the uniforms of intellectuals, writers, and journalists all over the world. It later wound up, on and off, in fashion shows, from Yves Saint Laurent to Giorgio Armani, down to the monogrammed GG, LV, and DG—Gucci, Louis Vuitton and Dolce & Gabbana—versions of recent seasons.

Dozens of familiar, common items in our everyday wardrobe have shared a similar fate: the wool pea coat of sailors, the leather flight jacket of pilots, the fur-edged hooded parka of explorers, safari jackets and cargo pants, multipocket vests, and backpacks.

The short coat known as an Eisenhower jacket is a perfect example of the way national borders become useless against the power of fashion. This garment—Wool Field Jacket M1944—was originally a combat jacket cut short at the waist for comfort and to save on fabric. First worn by the English troops during World War II, was so admired by General Eisenhower, the head of the Allied Forces in Europe and future president of the United States, and so popular among American soldiers that it became Eisenhower’s most famous outfit, the most known uniform of the U.S. Army and the most common piece of sportswear in the male wardrobe. In the modern version, the buttons have been replaced by zippers, and a designer logo has taken the place of the decorations, but the proportions remain the same: wide around the chest and narrow at the waist with broad shoulders.

Soldiers in every war have come back from the front with new experiences and terrifying tales, but also with military garments that silently became a part of everyday dress. The functional quality and the comfort tested in combat, the technology used to create new, more resistant fibers and fabrics, and the economy of resources and materials represented a legacy, which the clothing industry ably transferred from military to civilian production.

While the more theatrical characteristics of uniforms are just a memory in the technologically advanced equipment issued to modern soldier, the 1990s and 2000s have seen an increase and refinement of the political, revolutionary, or conservative use of those same details. In the uniforms from the 1930s, as in the outfits of rock stars or runways models fringed epaulettes on capes, silver buckles on shiny high boots, hussar braiding on riding jackets, coats of arms, decorations, metal eagles, and gold buttons are all defining elements. Freed from their practical function—the epaulette was created as protection against blows of the sword—these elements have assumed a symbolic and at times ideological value, but increasingly serve just a decorative purpose. These include the Armani eagle, the Versace medusa head, and the crossed C’s of Chanel.

See also **Camouflage Cloth; Uniforms, Military; Unisex Clothing.**

#### BIBLIOGRAPHY

- Brubach, Holly. “Running a Fever.” *New York Times Magazine*, 13 July 1997: 45.
- Edwards, T. *Men in the Mirror: Men’s Fashion, Masculinity and Consumer Society*. London: Cassel, 1997.
- Greco, L. *Homo Militaris: Antropologia e letteratura della vita militare*. Milan: Angeli, 1999.
- Finkelstein, J. *The Fashioned Self*. Cambridge, U.K.: Polity Press, 1991.
- Nathan, J. *Uniforms and Non-Uniforms: Communication through Clothing*. New York: Greenwood Press, 1986.

Stefano Tonchi



**MILLINERS** Milliners create hats for women; hat makers make hats for men. This is the nineteenth- and twentieth-century differentiation of the two trades, which, although related, require very different technical skills and working practices.

The term “millinery” is derived from “Millaners,” merchants from the Italian city of Milan, who traveled to northern Europe trading in silks, ribbons, braids, ornaments, and general finery. First chronicled in the early sixteenth century, these traveling haberdashers were received by noble aristocratic households, passing on news of the latest fashions as well as selling their wear. News of the latest styles and variations on dress was as important to men as it was to women, and milliners often acted as much sought-after fashion advisers to nobility all over Europe. One such milliner is mentioned by William Shakespeare in the historical drama *Henry IV* part 1, written in 1597, when the gallant warrior Hotspur refers to his encounter with a “trimly dress’d lord” as:

Fresh as a bridegroom; and his chin reap’d  
Show’d like a stubble-land at harvest-home;  
He was perfumed like a milliner;  
And ‘twixt his finger and his thumb he held  
A pouncet-box.

Milliners would also have traded in fine Florentine straw hats, a trade that might have been the reason for some of them to settle down as hat makers. Creating extravagant hats as well as having a flair for fashion and finery were, and still are, the trademarks of successful milliners.

The first celebrated “Marchande de Mode,” or “modiste” as they were later called in France, was Rose Bertin (1744–1813). Her name is linked with Queen Marie-Antoinette of France, the most extravagant and ill-fated fashion icon of the eighteenth century. It could be argued that Marie-Antoinette and her “Ministre de Modes,” Rose Bertin established haute couture in Paris and thus made it the capital of fine fashion. Elaborate hats, demure straw bonnets, and extravagant headdresses, called “poufs” were the height of fashion in the last quarter of the eighteenth century. Rose Bertin’s witty creations were perched high up on the coiffure and featured rising suns, miniature olive trees, and, most famously, a ship in full sail. Her fame was enhanced by her notoriety and attracted an array of ladies of European nobility. Her salon survived the French Revolution but sadly all her hats, just like her famous clients, have disappeared and can only be traced in copies of the *Journal des modes*, which according to the custom of the period, never mentioned or credited the designer or creator of model hats.

The fashion for straw bonnets spread to the newly independent America and with it the millinery trade. Betsy Metcalf of Providence, Rhode Island, was one of the first milliners in the United States. She is said to have invented a special way of splitting locally grown oat straw, which she bleached in sulfur fumes, plaited, and sewed



**Lady's portrait of gown and elaborate straw hat, 1796.** Straw bonnets were popular fashion accessories throughout the eighteenth century. © HISTORICAL PICTURE ARCHIVE/CORBIS. REPRODUCED BY PERMISSION.

in spirals, creating straw bonnets intersected with fine lace and lined with silk. Having started to make hats at the age of twelve, she set the trend for new straw weaving techniques and became the founder of American millinery. The production of straw hats became an important home industry and rivaled the expensive imports of Florentine (Leghorn) straw from Italy. A bonnet that is said to be one of Betsy Metcalf's is in the collection of Rhode Island's Literary and Historical Society.

During the nineteenth century, bonnets and hats were not only fashionable, but essential in any woman's wardrobe. Bonnets were romantic and coquettish and thus the perfect accessory for women of the era. Millinery flourished, led by a strong force of Parisian “modistes,” who set the tone for high fashion and demanded to be addressed reverently as “Madame.” Famous names were Madame Herbault, Madame Guerin, and Madame Victorine, who created Queen Victoria's bonnets. Society ladies expected milliners to create unique models and jealously kept their sources secret. Sadly, not many hats survived, as they were often restyled or the trimmings



**Milliner Frederick Fox, March 9, 1993.** This famous hatmaker, shown in his studio, was a royal milliner for Queen Elizabeth II. Based in London, Fox's career peaked during the 1970s and 1980s. © TIM GRAHAM/CORBIS. REPRODUCED BY PERMISSION.

reused. Testimony of some exquisite creations can only be found in illustrations and pictures without the mention of the relevant designer or maker. However, as millinery thrived on both sides of the Atlantic, millinery designers established their personal creed and reputation.

Caroline Reboux, at the Maison Virot, was the first legendary Parisian couture modiste, making hats for the French Empress Eugénie in 1868. She reputedly created individual designs by cutting and folding felt or fabric directly on the customer's head. Her famous salon in the rue Saint Honoré survived until the 1920s. Her pupil Madame Agnes became equally sought after for her experimental surrealistic styles. Elsa Schiaparelli, the Italian-born couture designer and friend of Salvador Dali, also created surreal hats in the 1930s. She unleashed her artistic talents by creating hats using newspapers, seashells, and birdcages with singing canaries. Her Shoe Hat designs of 1937, famously worn by Daisy Fellowes, editor of *Harper's Bazaar*, made headlines on both sides of the Atlantic.

Gabrielle (Coco) Chanel was a milliner before she started her couture career. She established her first salon in the elegant apartment of her lover in Paris in 1910. An avant-garde fashion trend leader of her time, she created

simple shapes and decorated sparingly to compliment her vision of modern dress. She is credited with the creation of the cloche hat, which, pulled down low over the new short hairstyles, was to become an all-time classic.

Other famous Parisian modistes of the 1930s and 1940s included Maria Guy, Rose Valois, Suzanne Talbot, Rose Descart, Louise Bourbon, and Jeanne Lanvin, who like Chanel expanded her millinery salon into haute couture. Most couture houses, like Dior, Jean Patou, or Nina Ricci, had their own millinery ateliers, all headed by a "Premiere" (Designer), a "Seconde" (Head of Workroom), with several workrooms full of "Petites Mains" (workers). Millinery hierarchy had strict rules of etiquette, with La Premiere and La Seconde always addressed as "Madame" and the inferior workers given diminutive names like Mimi, Gigi, and Flo-Flo. Milliners working in couture houses considered themselves superior to their dressmaking colleagues. The girls had a reputation for being pretty and coquettish, were always meticulously groomed, and spent more money on lipsticks and powder than on food and rent. The industry had economic importance, with top ateliers employing up to 300 milliners each.

Parisian milliners not only created hats for a selective private clientele, they also supplied a thriving wholesale export business to many stores in the United States. Lilly Daché, a Viennese-born, Parisian-trained milliner, settled in New York and led the way for talented American designers. Having opened her first tiny studio in 1926, Lilly Daché built a millinery emporium, taking over a whole building of seven floors, with a silver room for her blonde clients and a gold one for brunettes. Her devotees included the Hollywood stars Carmen Miranda, Betty Grable, and Marlene Dietrich, who all loved her chic toques, demure snoods, and stylish “profile hats,” which were her trademark.

Sally Victor and Mr. John of New York later took over the reign of Lilly Daché and maintained the importance of American millinery design. Mr. John had been in partnership with Frederic Hirst since 1928 and established his own business in 1948. His famous clients included Marilyn Monroe, Lauren Bacall, and Mrs. Simpson, the future Duchess of Windsor. Toward the end of his career Mr. John of N.Y. collaborated with Cecil Beaton on the extravagant costumes for Audrey Hepburn in *My Fair Lady*.

In Europe, the most notable milliner of the interwar years was Adele List in Vienna, whose hats were an expression of aesthetics and art. She was a highly disciplined, austere-looking figure and created hats with masterly craftsmanship. Using felt, straws, silks, and feathers, she combined shape, proportion, and texture in a unique harmonious way, which never looked dated. Some of her intricate pieces took over fifty hours to make and had detachable necklaces built into the shapes. One devoted client collected and preserved 248 model hats created by Adele List, all preserved in individual hatboxes. After her death, the collection was donated to the Museum of Applied Art in Vienna, Austria, in 1983.

Aage Thaarup was a Danish milliner established in London and the first in a line of male milliners who were to dominate the second half of the twentieth century. He was self-taught and broke the established French rules of apprenticeship and gradual mastery of millinery. Having charmed the core of his high-society clientele on a voyage to India, his reputation spread quickly, and drew in ladies of the British Royal family, including the duchess of York and her daughters, Elizabeth and Margaret. When the duchess became queen of England in 1936, Aage Thaarup was officially “appointed by Her Royal Highness” and later created hats for the young Queen Elizabeth as well as for the Queen Mother.

Paris still dominated the millinery scene until the 1960s, when London took the lead with Otto Lucas, who established a most successful model wholesale business in Bond Street. His designers and ideas still came from Paris, but his flair for style created a chic, modern look much praised by millinery buyers on both sides of the Atlantic. Madame Paulette, his favorite designer, was the last of the



**Headdress by Philip Treacy, 2001.** Emblematic of Treacy's flamboyant style, this headdress-style hat formed part of his 2001 couture collection, shown in Paris on July 10, 2001. AP/WIDE WORLD PHOTOS. REPRODUCED BY PERMISSION.

*grandes modistes* of the Parisian school. With Claude Saint-Cyr, Jean Barthelet, and Jean-Charles Brosseau, she was part of an era sadly in decline during the 1970s. At the height of her career Paulette had reigned over a much admired hat salon, with workrooms of 125 milliners and 8 *vendeuses mondaines*, society ladies with personal relations to important clients. Paulette created twice-yearly collections of 120 hats, presented to powerful foreign buyers as well as to her distinguished high-society clientele. Paulette's trademark was *le chapeau mou*, her draped soft turban, a sophisticated headwear for “bad hair days,” popular during the 1940s and 1950s. Few of her clients knew that Algerian soldiers had inspired Paulette's original turban design during the liberation parade on the Champs Elysées in 1944.

Youth culture and the social liberation during the 1960s and 1970s brought a demise in the fashion for hats and with it a steep decline in business for milliners. The 1980s heralded a brief revival, which was partly due to Princess Diana, a fashion leader and icon of the British hat industry. London held on to its lead in millinery design, supported by royal patronage and social summer events like horse racing at Royal Ascot and Garden Parties at Buckingham Palace. John Boyd, Graham Smith, and the royal milliners Frederick Fox and Philip Somerville, a quartet of hat designers during the 1970s and 1980s, managed very successful model millinery as





**Crimson hat and suit by Philip Treacy, 2000.** Created for the annual London Fashion Week and modeled on September 23, 2000, this crimson hat and matching suit reveal Treacy's skill of creating art from fashion. © AP/WIDE WORLD PHOTOS. REPRODUCED BY PERMISSION.

well as wholesale businesses in London. Small factories in Luton, Bedfordshire, U.K. supported manufacture, which, historically had been the center for straw hat production in the nineteenth century. Some factories, millinery supply businesses, and block makers are left in the early 2000s, but a museum has a rich collection documenting the importance of the hat trade in the past.

During the 1980s, a new generation of millinery designers graduated from London's Fashion and Art Colleges, creating hats as pieces of art. David Shilling was the first, gaining notoriety and much press coverage with striking Ascot creations he designed and made for his mother. Mrs. Gertrude Shilling's entrance, wearing yet another extraordinary hat, was much anticipated and celebrated every year at Royal Ascot.

Patricia Underwood was a star milliner in New York during the 1980s and 1990s, with her unmistakable style of pure shape and simplicity. New York also had Eric Javits, a very successful millinery designer, who built a multimillion-dollar business and was voted Hat Designer of the Year by the Millinery Institute of America. Millinery has also declined in the United States, but the Headwear Information Bureau (HIB) founded in New York in 1989, promotes millinery with public relations and competitions for young designers.

Stephen Jones, a New Romantic of the 1980s, included men among his devoted clients, and created hats for the pop stars Boy George and Steve Strange, as well as for the Spandau Ballet. His hat salon in London's Covent Garden district was designed to be full of fun, wit, and unexpected details. Stephen Jones is a rebel with a romantic streak and designs an eclectic mix of very wearable fabric hats, which reflect his original training as a tailor. Apart from creating diffusion ranges under the label "Miss Jones" and "Jonesboy," Stephen Jones works with many of the new top designers, such as Jean-Paul Gaultier, Claude Montana, and John Galiano, creating headpieces for cutting-edge catwalk shows.

Philip Treacy, an internationally awarded accessory designer, graduated from London's Royal College of Art in 1990 and immediately hit the headlines with his flamboyant and unmistakable hat creations, lifting millinery to an even higher level of art and design. The meteoric rise of the Irish-born young designer was also much celebrated at Parisian catwalk shows, staged by top couture houses like Dior, Chanel, and Givenchy. Philip Treacy even created his own millinery show in 1993, when supermodels paraded wearing show-stopping creations, acclaimed by the fashion press. One of his famous, much-photographed pieces was a hat with a black sailing ship, which might have been inspired by Rose Bertin's design in the late eighteenth century. A true and devoted lover of his craft, Philip Treacy personally makes many of his masterpieces. His label has become a status symbol and some of his celebrated hats are collector's pieces, treasured by museums, like the Victoria and Albert Museum in London.

During the twentieth century, women's lives changed drastically and imposed a fast-living lifestyle not compatible with the ethos of beautiful hat creations. The twenty-first century has become a bare-headed era and glamorous hats have become "special occasion wear," only worn for weddings and high-society horse races. However, it is conceivable that the next generation of young designers might reinvent millinery with a new concept and purpose.

See also **Chanel, Gabrielle (Coco); Hats, Men's; Hats, Women's; Lanvin, Jeanne; Schiaparelli, Elsa; Treacy, Philip.**

#### BIBLIOGRAPHY

Buxbaum, Gerda. *Die Hute der Adele List*. New York: Prestel Munchen, 1995.

Ginsburg, Madeleine. *The Hat, Trends and Traditions*. London: Studio Editions, Ltd., 1990.

Hopkins, Susie. *The Century of Hats*. London: Aurum Press, 1999.

McDowell, Colin. *Hats, Status, Style and Glamour*. London: Thames and Hudson, Inc., 1992.

Muller, Florence, and Lydia Kamitsis. *Les chapeaux, une histoire de tête*. Paris: Syros Alternatives, 1993.

*Susie Hopkins*

**MINISKIRT** The debut of the miniskirt in the early 1960s can be compared to the birth of rock'n'roll music. When rock'n'roll took hold in the 1950s, parents and clergy were up in arms, railing against it. They were hopeful that it was a fad that would play itself out and fade away. Neither the miniskirt nor rock'n'roll has faded away. They have both endured and continue to serve as chief symbols of youthful rebellion.

Fashion history is characterized by the shifting focus on one female "erogenous zone" of the body to another. The fashionable Victorian silhouette focused attention on the waist, bosom, and hips through the use of corsetry. By the beginning of the twentieth century, the "mono-bosom" was prominent. During the 1920s, the flapper-style dress, which was based on a loose tunic or tubular shift, dared to reveal more of the female leg than ever before in modern Western history. However, fashion reverted to longer hemlines by the 1930s. Just as Art Deco set the stage for modern art, so did the fashions of the Jazz Age pave the way for the miniskirt.

While the decade of the 1950s embraced prescribed rules of dressing for special occasions and time of day, there was a new freedom in the area of casual clothing. The ideal fashionable woman was a statuesque adult, and young women were expected to imitate adult styles when it came to dressing. Teenagers tended to wear grown-up versions of clothing, except for casual wear. But rumblings of change were in the air.

### Mary Quant

American teenagers of the 1950s and 1960s, later dubbed baby boomers, were taking note of each other on television dance party shows spawned by Dick Clark's "American Bandstand" in Philadelphia, especially after it went nationwide in 1957. Great Britain, which lagged behind the United States in recovering from World War II, was also giving birth to its own baby boomers. Among them was the intrepid Mary Quant, whose name is forever linked with the creation of the miniskirt.

Quant was part of the restless youth culture in the Chelsea section of London. Along with her friends Alexander Plunkett Green (who later became her husband) and Archie McNair, Quant felt that clothing for her age group did not really exist, so they opened their own shop called *Bazaar* in 1955. Quant infused her de-

signs with a fresh, youthful energy, and even appeared at Buckingham Palace in a miniskirt to receive the Order of the British Empire in 1966. Along with the Beatles, Quant reinvigorated British culture, helping to launch the phenomenon known as "swinging London." Quant once noted, "London led the way to changing the focus of fashion from the Establishment to the young. As a country we were aware of the great potential of these clothes long before the Americans and the French."

Short skirts were incompatible with garters and stockings, making tights a vital new option. Already in the early 1940s, American designer Claire McCardell had presented her tunic-jumpers with dance leotards. However, the relatively high cost of producing tights kept them a novelty until the 1960s, when colored tights diffused some of the overt sex appeal of the miniskirt. Soon panty hose had largely replaced stockings and garter belts.

### André Courrèges

By 1960, more than half of the world's population was under the age of 25, but it took some time before the Paris haute couture recognized the emergence of youth style. By the early sixties, however, even couture-trained designers, such as Pierre Cardin and André Courrèges, began designing youthful styles.

When Courrèges presented his autumn 1964 collection, it affected fashion as dramatically as Christian Dior's "New Look" had done in 1947. Courrèges' 1964 collection included stark, modern designs that were futuristic and electrifying. In addition to carefully sculpted tunics and trousers made out of heavy wool crepe, Courrèges created his version of the miniskirt. He paired his shorter skirts with white or colored leather, calf-high boots that added a confident flair to the ensemble. This look became one of the most important fashion developments of the decade and was widely copied. Scores of other designers embraced the miniskirt concept and strove to adapt the look for clients of various ages.

While the miniskirt did not always complement each and every figure, almost every Western woman eventually tried some version of the style during the 1960s. Young women were the first to embrace it, despite resistance from parents and school administrators. The miniskirt became a symbol of the sexual revolution, as the contemporaneous invention of the birth control pill liberated women from the specter of unplanned pregnancies.

Whereas during the early twentieth century short hemlines were associated with prostitutes and theatrical performers, by the 1960s short hemlines were also adopted by "respectable" women. The miniskirt was synonymous with Mod style. By 1969 the miniskirt evolved into the "micro-mini." As Mods gave way to hippies, however, subcultural styles increasingly emphasized long, romantic skirts. By 1970, the fashion industry had launched "midi" and "maxi" skirts, which dominated the following decade.

In the early 1980s, the miniskirt made a comeback, linked again with the power of music and the rise of MTV. Music videos promoted highly charged, sensual images of female performers wearing skimpy clothing. Rap and hip-hop performers have promoted their music by using miniclads in their videos. The miniskirt, first unleashed by Mary Quant and André Courrèges, has come and gone every few seasons on the fashion runways, but it has become a mainstay of popular culture.

See also **Courrèges, André; Quant, Mary; Youthquake Fashions.**

**BIBLIOGRAPHY**

- Bond, David. *The Guinness Superlatives Guide: 20th Century Fashion*. Middlesex: Guinness Superlatives Limited, 1981.
- Buxbaum, Gerda, ed. *Icons of Fashion: The 20th Century*. Munich, London and New York: Prestel, 1999.
- Ewing, Elizabeth. *History of 20th Century Fashion*. 3rd ed. Lanham: Barnes and Noble Books, 1992.
- Glynn, Prudence. *Skin to Skin: Eroticism in Dress*. New York: Oxford University Press, 1982.
- Lehnert, Gertrud. *A History of Fashion in the 20th Century*. Cologne: Köneman, 2000.
- Lobenthal, Joe. *Radical Rags: Fashions of the Sixties*. New York: Abbeville Press Publishers, 1990.

*Myra Walker*

**MISSONI** Since it was established in 1953, the Missoni company has been associated with expertly produced, lightweight, delicate knit separates. The company quickly established its image by combining innovative and fractured stripes, plaids, patchworks, ethnic effects, mosaics, zigzags, and flame stitch patterns in vivid and striking color combinations.

Young Ottavio (Tai) Missoni, a former athletic sprinter, and Rosita Jelmini, a language student, first conceived the company in 1953. Tai's workshop initially produced track suits. Through Rosita's family of manufacturers, knitting machines became available at a time when patterns were knitted only in horizontal and vertical stitches. The pair had the machines reconfigured for more modern alternatives. After the couple married, Rosita chose to become the firm's business manager. With his extraordinary eye for color, Tai focused his efforts on arranging color palettes.

Beginning with their first runway presentation in 1967, at the Pitti Palace, in Florence, the Missonis attracted attention. Fashion writers and arbiters of style such as Diana Vreeland and Bernardine Morris were the first to publicize the Missoni style. By the 1970s the rust-brown Missoni cloth label was recognized worldwide as a status symbol. Along with their artisanal approach and spirited color combinations, the Missonis developed their expertise in striping, scalloping, waves, prints, and jacquard dots. They used as many as twenty different ma-

terials, combining wool, cotton, linen, rayon, and silk in forty color selections.

In the mid-1990s Angela Missoni initiated a reinterpretation of the company's image, making her mark on her parents' label. Her intent was to update the Missoni line by creating redefined and edited collections of bright and sporty garments. Since 1998 Angela has held the position of design director, responsible for developing advertising campaigns with Mario Testino, the noted fashion photographer, in addition to retail sales and the interior design of retail stores. Her revised approach to marketing the brand emphasizes promoting the image of a more youthful, urban clientele. Her daughter, Margherita, serves as her assistant. Her brothers also are active in the family company: Vittorio is responsible for marketing and sales, and Luca directs research in fabric developments and computer technology. In 2003 he was made responsible for the development of the men's wear collection.

In the early 2000s the company employed about 250 craftspeople and technicians, designers, and administration staff at its Sumirago, Italy, enclave outside Milan. Displays of experimental knitting methods and scraps of fabric and yarn lie in a profusion of color on the factory floor. New materials and ideas are posted on the studio walls. The Missonis describe themselves as a working team of artisans and nurture that image.

The Missoni firm is identified with their collaging of unusual color combinations, patterns, and weights of sumptuous yarns. Layered knit patterns emerge from modern, computerized jacquard looms. Early in the twenty-first century the firm was producing about 150 new textiles and designs every year. The Missoni name can also be found on original collections of home furnishings, accessories, swimwear, cosmetics, and perfume.

The company owns more than twenty licensing agreements for men's wear, women's wear, accessories, children's apparel, linens, and furnishings, but the owners have been cautious about extending licensing agreements too far. The firm has ventured into fabrics for automobile interiors and also into theatrical costuming. Angela Missoni, her brothers, and their children seem eminently poised to proceed with the family love of color and their commitment to the continued success of the Missoni label.

See also **Color in Dress; Knitting Machinery.**

**BIBLIOGRAPHY**

- Arte, Leonard, and Samuele Mazza. *Missoni (Made in Italy)*. Corte Madera, Calif.: Ginko Press, 1997.
- Missoni, Ottavio, et al. *Ottavio e Rosita Missoni Story*. Milan, Italy: Skira, 1995. An exhibition catalog.
- Vercelloni, Isa Tutino, ed. *Missonologia: The World of Missoni*. New York: Abbeville, 1995. An exhibition catalog.

*Gillion Carrara*



**MIYAKE, ISSEY** Issey Miyake was born in Hiroshima, in the southern part of Japan, in 1938. In 1965 he graduated from Tama Art University in Tokyo, where he majored in graphic design. Following graduation, he went to Paris just three months after Kenzo Takada, the first Japanese designer to become successful in France, arrived there. Miyake and Kenzo had known each other in Tokyo, and they studied together at a tailoring and dressmaking school, l'École de la chambre syndicale de la couture. In 1966 Miyake worked as an apprentice under the French couturier Guy Laroche, and two years later he apprenticed at Givenchy.

He then went to New York to work with the American designer Geoffrey Beene before returning to Tokyo, where he founded the Miyake Design Studio in 1970. One of Miyake's New York friends took some of his design samples to *Vogue* magazine and a major department store, Bloomingdale's. Both *Vogue* and Bloomingdale's were enthusiastic about his work, and Bloomingdale's was so im-

pressed that Miyake got a small section in the store. His first small collection in New York included T-shirts dyed with Japanese tattoo designs and *sashiko*-embroidered coats (*Sashiko* is a Japanese sewing technique that gives strength to the fabrics used in clothing designed for workers). In 1973, when French ready-to-wear was institutionalized for the first time as prêt-à-porter, Miyake was invited to Paris to join a group show with such other young designers as Sonia Rykiel and Thierry Mugler. He opened a boutique there two years later and continued to show his collection in Paris. Miyake later became an official member of the French prêt-à-porter organization.

#### **Founded Japanese Avant-Garde**

Miyake laid the foundation in Paris for avant-garde designers worldwide, the Japanese ones in particular. He was showing in Paris long before other Japanese designers, and his presence was further pronounced by the emergence of two influential, norm-breaking designers.



**Issey Miyake fashion show.** Models for avant-garde designer Issey Miyake show off his Japanese-inspired fashions. Bold fabric patterns and unusual shapes and lines typify Issey's quest to fuse his Japanese heritage with modern, Western clothing styles. AP/WIDE WORLD PHOTOS. REPRODUCED BY PERMISSION.



"I am neither a writer nor a theorist. For a person who creates things to utter too many words means to regulate himself, a frightening prospect."

Issey Miyake quoted in *Issey Miyake Bodyworks* 1983, p. 99.

Rei Kawakubo, working under the label Comme des Garçons, and Yohji Yamamoto began to present their collections in Paris in 1981 along with the already-established Miyake, who is considered the founding father of the new fashion trend. These three effectively started a new school of Japanese avant-garde fashion, although it was never their intention to classify themselves as such. Kawakubo said in an interview with Olivier Séguret in *Madame Air France*, "We certainly have no desire to create a fashion threesome, but each of us has a strong urge to design new, individual clothes which are recognizably ours" (pp. 140–141). Similarly, Miyake is quoted in Dana Wood's article in *Women's Wear Daily* as follows: "In the Eighties, Japanese fashion designers brought a new type of creativity; they brought something Europe didn't have. There was a bit of a shock effect, but it probably helped the Europeans wake up to a new value" (p. 32).

Miyake was the first to redefine sartorial conventions. His clothing patterns were very different from the Western styles in that he restructured the conventional construction of a garment. As the *Time* magazine writer Jay Cocks observed:

"Issey," asks one of his friends, standing in the middle of a bustling hotel lobby, "how do I work this?" . . . "I made it like this," says the designer . . . He unbuttons a half-cape that spans the sleeves, and puts the loose ends around his friend's neck. (p. 46)

A student who worked as a dresser backstage at one of Miyake's show in the late 1980s recalled the intricate construction of his garment:



"When I first began working in Japan, I had to confront the Japanese people's excessive worship for foreign goods and the fixed idea of what clothes ought to be. I wanted to change the rigid formula of clothing that the Japanese followed."

Issey Miyake quoted in *Issey Miyake Bodyworks* 1983, p.103.

There was a garment that was totally out of shape and had four holes. You could hardly tell which holes are supposed to be for the arms to go in or the neck to go in. During the rehearsal, Issey's patternmakers would be going around the dressers making sure we knew which hole was for which part of the body. Models usually come running back from the stage to get changed to the next outfit, and it is our job to help them get dressed as quickly as possible with the right shoes, the right accessories and so on. It's a mad house at the back during the show. At that point, you have no time to think which hole goes where! Some dressers couldn't match the neck to the right hole. It was totally wrong. But who can tell?

In other words, it is up to the wearer to be creative and decide how to wear it. Miyake claims that simplicity is often the key to wearing his clothes, which are versatile enough to be worn in a variety of ways.

Western female clothes have historically been fitted to expose the contours of the body, but Miyake introduced large, loose-fitting garments, such as jackets with no traditional construction and a minimum of detail or buttons. His dresses often have a straight, simple shape, and his large coats with sweepingly oversized proportions can be worn by both men and women. He challenged not only the conventions of garment construction, but also the normative concept of fashion. All of this came at a time when women's clothes by most traditional Western designers were moving in the opposite direction, toward a tighter fit and greater formality. The avant-garde Japanese view of fashion was opposed to the conventional Western fashion. It was not Miyake's intention to reproduce Western fashion, as he pointed out in his speech at the Japan Society in San Francisco in 1984:

I realized that my very disadvantage, lack of western heritage, would also be my advantage. I was free of Western tradition or convention . . . The lack of western tradition was the very thing I needed to create contemporary and universal fashion.

### Sculptor of Fabric

Miyake is best known for his original fabrics. He collaborates with his textile director, Makiko Minagawa, who interprets his abstract ideas. With Minagawa and the Japanese textile mills, he introduced his most commercially successful collection, Pleats Please, in 1993. Traditionally, pleats are permanently pressed before a garment is cut, but he did it the other way round. He cut and assembled a garment two-and-a-half to three times its proper size. Then he folded, ironed, and oversewed the material so that the straight lines remained in place. Finally the garment was placed in a press between two sheets of paper, from which it emerged with permanent pleats (Sato 1998, p. 23).

As early as 1976 Miyake began his concept of A-Piece-of-Cloth (A-POC), or clothes made out of a single piece of cloth that entirely cover the body. He introduced the line, which evolved from his earlier concept, in 1999.



**Issey Miyake and Dai Fujiwara exhibit in Berlin, 2001.** Japanese designers Issey Miyake and Dai Fujiwara show their A-Piece-of-Cloth (A-POC) designs at the Vitra Design Museum in Berlin, Germany. Each garment item is fashioned from one single piece of fabric. © SEIMONEIT RONALD/CORBIS SYGMA. REPRODUCED BY PERMISSION.



The A-POC clothes consist of a long tube of jersey from which individuals can cut without wasting any material. A large variety of different clothes can be made in this manner; the tubes are manufactured with an old knitting machine controlled by a computer and can be made in large quantities. His objective was to minimize waste by using all leftover material. These garments allow the buyer to size and cut out a small hat, gloves, socks, a skirt, or a dress. Depending on the way the dress is cut, it may appear in two or three pieces. In addition to Miyake's A-POC project, new techniques of sewing garments, such as heat taping and cutting by ultrasound, were also featured in his *Making Things* exhibition at the Fondation Cartier pour l'art contemporain in Paris in 1999.

### Place in History

No history of fashion is complete without the mention of Issey Miyake, as he has made a major contribution to the world of fashion. Miyake retired from the Paris fashion scene in 1999, when Kenzo also decided to withdraw from his own brand. The Issey Miyake brand was taken over by Naoki Takizawa, who had been designing Miyake's Plantation Line since 1983 and Issey Miyake Men since 1993. Many of Miyake's former assistants, such as Yoshiki Hishinuma and Zucca (Akira Onozuka), now participate in the Paris Collection.

Every convention carries with it an aesthetic, according to which—what is conventional becomes the standard by which artistic beauty and effectiveness is judged. The conception of fashion is synonymous with the conception of beauty. Therefore, an attack on a convention becomes an attack on the aesthetic related to it. By breaking the Western convention of fashion, Miyake suggested the new style and new definition of aesthetics. It could have been taken as an offense not only against the Western aesthetic, but also against the existing arrangement of ranked statuses, a stratification system in fashion, or the hegemony of the French system.

Miyake's cutting-edge concept that there is beauty in the unfinished and the neglected has had a major influence on today's fashion. Miyake says, "I do not create a fashionable aesthetic . . . I create a style based on life" (Mendes and de la Haye 1999, p. 233). He is opposed to the words "haute couture," "mode," and "fashion," because they imply a quest for novelty; he stretched the boundaries of fashion, reshaped the symmetry of clothes, let wrapped garments respond to the body's shape and movement, and destroyed all previous definition of clothing and fashion. His concepts were undoubtedly original, especially when compared to the rules of fashion set by orthodox, legitimate Western designers such as Coco Chanel, Christian Dior, and Yves Saint Laurent. It was Miyake who set the stage for the Japanese look in the fashion establishment.

See also **Japanese Fashion; Trendsetters.**

### BIBLIOGRAPHY

- Cocks, Jay. "A Change of Clothes: Designer Issey Miyake Shapes New Forms into Fashion for Tomorrow." *Time*, January 27, 1986, 46–52.
- Holborn, Mark. *Issey Miyake*. Cologne, Germany: Taschen, 1995.
- Koike, Kazuko, ed. *Issey Miyake, East Meets West*. Tokyo, Japan: 1978.
- Mendes, Valerie, and Amy de la Haye. *20th Century Fashion*. London, New York: Thames and Hudson, Inc., 1999.
- Miyake, Issey. Speech delivered at Japan Today Conference in San Francisco, September, 1984.
- . *Issey Miyake and Miyake Design Studio: 1970–1985*. Tokyo, Japan: Oubunsha, 1985.
- Sato, Kazuko. "Clothes Beyond the Reach of Time." *Issey Miyake: Making Things*. Paris: Fondation Cartier pour l'art contemporain 1998, 18–62. An exhibition catalog.
- Séguret, Olivier. "Les Japonais." *Madame Air France* no. 5 (1988): 140–141.
- Tsurumoto, Shogo, ed. *Issey Miyake Bodyworks*. Tokyo, Japan: Shogakkan, 1983.
- Wood, Dana. "Miyake's Lust for Life." *Women's Wear Daily*, December 18, 1996, p. 32.

Yuniya Kawamura

**MODACRYLIC.** See **Acrylic and Modacrylic Fibers.**

**MODERN PRIMITIVES** The Modern Primitive subculture exists primarily in North America and Europe. Members are known for their use of body modifications, such as blackwork tattoos (i.e., heavy black ink applied and reapplied until the color of the skin is completely obscured), three-dimensional implants, scarification, and brands. Utilizing both modern and ancient technology, members often participate in culturally authenticated rituals to achieve the desired body modifications. The subculture's basic ideology is to return to a simpler way of life, which they believe they can achieve through their body modifications.

### Modern Primitive History

Modern Primitive subculture members were first evident in the latter half of the 1960s. A self-proclaimed Modern Primitive and body artist, Fakir Musafar, originally named this subculture "Modern Primitive" because "modern" represents this subculture's connection to and place in the contemporary (urban) world, and "primitive" represents the primary or initial (non-Western) cultural groups.

Fakir Musafar is one of the most recognized and publicized members of the Modern Primitive subculture. Naming himself after a nineteenth-century Sufi who wandered through India for nearly two decades with heavy metal objects hanging from his torso's flesh as a spiritual sacrifice, Musafar has numerous body modifications, such

as septum, ear, and chest piercings, and blackwork tattoos. Articles in *National Geographic* and other such ethnographies about non-Western cultures, as well as personal visions, inspired many of his body modifications.

### Body Modification Technology

Modern Primitive subculture members have distinct appearances because of their extreme body modifications, achieved by a variety of both modern and ancient methods. Not only do members research the design, but some also research the techniques and tools to be used for their body modification. Steve Haworth invented instruments and techniques to insert transdermally or subdermally three-dimensional Teflon and surgical steel implants (for example capture jewelry).

### Body Modification Rituals

Some Modern Primitives acquire body modifications by participating in rituals, often inspired by non-Western cultures. For example, Musafar has acquired some of his most notable body modifications from participating in rituals, such as the Kavandi-bearing ceremony, where spears of Siva are placed through the skin to achieve spiritual transcendence; the Hindu Ball Dance, a ritual in which a Sadhu (i.e., an Indian holy man) is pierced by weight-bearing hooks as proof of religious fervor; and the Sun Dance, a Native American ceremony in which a participant is bodily hung from chest piercings as a token of personal sacrifice and endurance. Often the chosen rituals are modified to utilize a chosen technology, to incorporate the participant's spirituality and ideology, and to create the desired body modification. The result is a unique Modern Primitive body modification ritual.

### Ideology

Modern Primitives acquire body modifications as rites of passage, spiritual transcendence, and autonomy. Members of this subculture wear their body modifications as evidence of their experiences, often in an attempt to mimic non-Western cultures. Some subculture members claim that participation in these rituals allows spiritual transcendence via enduring the associated pain. Modern Primitives believe that pain is the key to connecting the real truth and the self in the modern world. Body modifications are the link between the contemporary world and the desired "tribal," "pagan," or "primitive."

See also **Branding; Goths; Punk; Scarification; Street Style; Tattoos.**

### BIBLIOGRAPHY

- Mercury, M. *Pagan Fleshworks: The Alchemy of Body Modification*. Rochester, Vt: Park Street Press, 2000.
- Musafar, Fakir. "Body Play: State of Grace or Sickness?" In *Bodies Under Siege: Self-Mutilation and Body Modification in Culture and Psychiatry*. Edited by A. R. Favazza, M.D. Maryland: Johns Hopkins University Press, 1996.
- Vale, V. and Juno, A. *Re/Search: Modern Primitives*. Hong Kong: Re/Search Publishers, 1989.

Winge, T. M. "Constructing 'Neo-Tribal' Identities through Dress: Modern Primitives Body Modifications." In *The Post-Subcultures Reader*. Edited by D. Muggleton and R. Wienzeirl. Oxford: Berg, 2003.

Theresa M. Winge

**MOHAIR** The Angora goat produces a long, lustrous white fiber called "mohair." The goat originated in the Angora province of Turkey, where it has been raised for thousands of years. The word mohair stems from the Arabic word for goat's-hair fabric, *mukbayyar*. In medieval times the fabric was called *mockaire*.

Mohair varies in length depending on the number of times per year that the goats are sheared. Mohair measuring 4 to 6 inches is sheared twice per year, and 8-to-12-inch mohair fiber is sheared once per year. It grows in uniform locks, but is relatively coarse compared with sheep's wool, making it less comfortable when worn next to the skin. Unlike wool it has no crimp or waviness in the fiber length. When mohair is obtained from Angora goats less than one year old, it is called "kid mohair" and is softer and finer than fiber from adult Angora goats.

Mohair fibers have a circular cross-section, which makes them lustrous to the eye. Mohair is much smoother than wool because of its faint scale structure, making mohair more resistant to dirt than sheep's wool. The fine scales do not allow mohair to be felted. The fiber has microscopic air ducts running through the cells, giving mohair a light, airy quality. Mohair fiber is very strong and has a superior affinity for dyes.

Mohair is used in knitted sweaters, upholstery pile fabrics, summer apparel, linings, coats, and imitation furs. It is a durable, long-lasting fiber. In the twenty-first century, Turkey, Texas, and South Africa provide the majority of mohair fiber for the world market.

See also **Angora; Dyeing; Fibers.**

### BIBLIOGRAPHY

- Hunter, L. *Mohair: A Review of Its Properties, Processing and Applications*. West Yorkshire, England: International Mohair Association, 1993.

Ann W. Braaten

**MOORE, DORIS LANGLEY** Doris Langley Moore was one of the foremost scholars and collectors of historic dress in the twentieth century, a cofounder of the Costume Society, and the founder of the Museum of Costume, Bath. Born in Liverpool, England in 1902, Doris Elizabeth Langley Levy spent her youth in Johannesburg, South Africa, where her father worked as a newspaper editor. She returned to England in the early 1920s and published her first book in 1926, the same year in which she married Robin Sugden Moore.

In addition to her significant work in the field of historic clothing, Moore had a long and varied career. She was a successful designer for stage and film; a television commentator; a well-known author of fiction and non-fiction, including biography; and a Byron scholar (in 1962 at Bowood House, Wiltshire, she discovered the Albanian ensemble worn by the romantic writer in a portrait of 1814 by Thomas Phillips). Moore's many achievements were recognized during her lifetime. She was made a Member of the Order of the British Empire in 1971; a Fellow of the Royal Society of Literature in 1973; and she was awarded the Rose Mary Crawshay Prize by the British Academy in 1975. Moore died in London in 1989.

Moore's enduring contributions to the field of costume history include her outstanding collection of men's, women's, and children's dress and accessories, primarily English and Continental, dating from the sixteenth through the mid-twentieth century, and amassed over four decades beginning around 1930; her numerous books, articles, and related publications both on her collection and on the wider subject of dress; and her establishment of the Museum of Costume in 1963, and of the Costume and Fashion Research Centre (a part of the museum) in 1974. At the time of its opening, the Museum had the largest collection of fashionable historic dress on view in Britain. Both the museum and the Research Centre remain important educational and study facilities for scholars, students, and the general public.

Moore's impressive and rigorous connoisseurship encompassed all aspects of dress history, including surviving garments, visual and literary source material, display, and fashion theory. *The Woman in Fashion* (1949) and *The Child in Fashion* (1953), in particular, attest to her detailed knowledge of the silhouette and its evolution, acquired by years of close observation of objects in her own and other collections. Beyond clothing itself, Moore's expertise included the mechanics of the fashion industry and representations of costume in portraits, prints, and fashion plates. In *Fashion through Fashion Plates* (1971), Moore examined both the history of the fashion press and the nature of the plate as an idealized image.

Although she would later change her mind about the appropriateness of using live models for historic dress (as she did in *The Woman in Fashion* and *The Child in Fashion*), Moore felt strongly about presenting the totality of a given period silhouette, without which she felt the main garment would be meaningless and misunderstood. Her displays at the museum in Bath featured realistic, fully accessorized mannequins, complete with real or simulated hair, set in lively vignettes.

Moore was a pioneer in the study of costume history and instrumental in bringing appreciation of the subject to a popular audience. The perceptive, inquiring, and far-ranging approach of her scholarship laid the foundation for future dress historians. Moore's publications are still considered important sources of information, and her ex-

emplary costume collection constitutes one of the most important in public institutions worldwide.

See also **Fashion, Historical Studies of; Fashion Museums and Collections.**

#### BIBLIOGRAPHY

- Byrde, Penelope. "Doris Langley Moore, 1902–1989." *Costume* 24 (1990): 149–151.
- Moore, Doris Langley. *The Woman in Fashion*. London: B. T. Batsford, 1949.
- . *The Child in Fashion*. London: B. T. Batsford, 1953.
- . *The Museum of Costume Assembly Rooms, Bath: Guide to the Exhibition and a Commentary on the Trends of Fashion*. Bath: Museum of Costume, [1969?].
- . *Fashion through Fashion Plates, 1771–1970*. London: Ward Lock, 1971.
- Taylor, Lou. *The Study of Dress History*. Manchester: Manchester University Press, 2002.

Michele Majer

**MORI, HANAE** Hanae Mori was born Hanae Fujii in Shimane, a prefecture in the southern part of Japan, in 1926. Immediately after graduating from the Tokyo Women's Christian University in 1947, she married Ken Mori, a textile executive. She was bored by fulfilling the role that was expected of most women in Japan at the time, which was being a wife and a mother to her two sons, Akira and Kei. Consequently, she enrolled in a dressmaking school to acquire the skills that led her to establish her first shop in 1951 in the center of Tokyo. A movie theater that showed the latest films from the West was located directly across the street from her shop. Movie director Sotojiro Kuromoto noticed the window display of her store one day, walked in, and asked Mori to design costumes for his films. As a result of this chance occurrence, her career was launched, and she became Japan's first internationally known designer.

After the defeat in World War II, Mori wanted to introduce to the world the positive and beautiful aspects of the country and used fashion as the means to give Japan a new image. Mori's fashions are especially noteworthy for their use of vibrant color and lustrous textiles. She designed costumes for the opera *Madame Butterfly* at La Scala, in Milan in 1985; the ballet *Cynderella* for the Paris Opera in 1986; and the opera *Electra* at the Salzburg Music Festival in 1996, among many others. She also designs costumes for the traditional Japanese theater, Kabuki. She has also made a contribution to the area of uniforms, such as the Japanese Olympics team in 1994 and the flight attendants in 1970.

In 1977 Mori was admitted to the exclusive French fashion circle of la Chambre Syndicale de la haute couture parisienne, the first Asian couturiere to be so honored. Admission to the organization is the ultimate title





For Hanae Mori, a suit made by Coco Chanel was a source of inspiration: "I was fascinated by the impeccable tailoring often found in men's suits. But it also looked elegant. . . . That experience motivated me to continue as a designer" (Mori, pp. 72–76).

that many prêt-à-porter designers aspire to achieve, though few realize their goals. In January 2003 the organization had only eleven members.

Mori introduced Japanese high culture, with its luxury and great beauty, to the West. She featured Japanese cultural products—such as cherry blossoms, Mount Fuji, Kabuki, and Japanese calligraphy—and applied them to Western aesthetics. One of her most famous trademarks is the butterfly, and she is therefore known as Madame Butterfly. Unlike Kenzo or the other avant-garde Japanese designers who used unconventional styles and fabrics, Mori did not attempt to break the system of Western fashion or alter its concept of clothing. What she challenged was the stereotypical, inferior image of the Orient and Japanese women that was current in the 1960s.

Mori remains exclusive among all the Japanese designers in Japan and in France because of her status as a *Couturiere*, the title that no other Japanese designers had attained in the early twenty-first century. She has received many prestigious awards, including the *Croix de chevalier des arts et lettres* (1984) and *chevalier of the Légion d'honneur* (1989), both from the French government. In 1989 the Japanese government designated her a *Person of Cultural Merit*.

Mori's enterprise was privately owned and managed by her husband, Ken, until his death in 1996, and later by her elder son, Akira. However, as the structure of the haute couture system began to change, the company was forced to go through an organizational transition. In 2001 the company announced that Mori's prêt-à-porter and licensing divisions had been sold to a British investment group, Rothschild, and a major Japanese trading company, Mitsui. Her haute couture division was sold in 2002. While Mori now designs only for her haute couture collection, which is shown biannually in Paris, her family members have completely withdrawn from her business.

See also **Costume Designer; Japanese Fashion; Textiles, Japanese.**

#### BIBLIOGRAPHY

Brabec, Dominique. "Hanae Mori." *L'Express* 10 (January 1977): 7.

Menkes, Suzy. "Hanae Mori: The Iron Butterfly." *Hanae Mori Style*. Edited by Yasuko Suita. Tokyo: Kodansha International, 2001.

Mori, Hanae. *Fasshon: Chou wa Kokkyou wo Koeru* (Fashion: A butterfly crosses the border). Tokyo: Iwanami Shinsho, 1993; reprint, 2000.

*Mori Hanae to Pari: Pari Oto Kuchuru Nijunen Tenran Kai* (Hanae Mori and Paris: Twenty years of Paris haute couture). Tokyo: Ginza Matsuya, 1998.

Suita, Yasuko, ed. *Hanae Mori Style*. Tokyo: Kodansha International, 2001.

*Yuniya Kawamura*

**MOSCHINO, FRANCO** Franco Moschino was born in Abbiategrasso, Italy, in 1950. He attended art classes at the *Accademia di Belle Arti di Brera* in Milan until 1969. Although he expected to be a painter, he pursued opportunities as a fashion illustrator for a variety of periodicals. He was a keen observer of the current art phenomena, from avant-garde to contemporary styles. Until 1983, Moschino collaborated with other manufacturers as a creative consultant with Aspesi, Blumarine, and Cassoli. Rather than inventing new styling, he combined existing elements in unexpected ways. His expertly tailored and classic styles, punctuated with whimsical detailing, were already apparent at the inception of his company, Moschino S.n.c., which became Moon Shadow S.r.l. in 1983. In 2000, the company was again renamed as Moschino S.p.A.

Moschino, a fashion show produced by the highly regarded Aeffe SpA, attracted media attention for the designer's persistence in appropriating garments as sign boards of irreverence and irony. In 1989, Moschino's signature line, *Couture*, was introduced during the "XX Olympics of Fashion." His second line, labeled *Cheap and Chic*, was introduced in 1988. During that unforgettable runway presentation, safety pins adorned evening clothes and garbage bags replaced woven fabric, reflecting surrealism and dadaism. Moschino previewed his *Uomo* menswear in 1986 and followed it with his *Diffusion* line in 1999. Superbly cut styling for *Jeans Uomo* arrived in 1996.

#### Business Innovations

The introduction of each of Moschino's lines featured accessories, fragrances, swimwear, eyewear, men's and women's clothing, and most notably jeans. Designs were provocatively and playfully posed in artistic vitrines, store interiors, showrooms, and even a corporate office. *Vignettes* are still represented as formidable instruments of communication for Moschino's acerbic wit, passions, and politics.

Theatrically dressed troubadours and character actors heralded the opening of Moschino's first boutique in Milan, in 1989. At the opening of the *Cheap and Chic*

store, canvases painted by Moschino transformed the retail space into a fine art gallery, Una Galleria d'Arte Finta. By 1991 he had opened boutiques in Rome, Los Angeles, and New York City. The displays that launched his New York store and his Milan store, with its controversial windows, in 1992 brilliantly expressed his opinions on environmental issues, drug addiction, racism, animal causes, and violence. Stores in Bangkok and Osaka opened in 1997.

In 1999, skilled designers and artisans revisited Moschino's iconographic themes; using unorthodox methods, they updated the decor of the original showroom and the retail store. Aware of the company's historic sense of humor and irreverent approach to design, designers enlarged and renovated the Milan office space—including the corporate office, showroom, and design studios—and installed amusing sculpture and artistic, structural detailing.

Since Moschino's death in 1994, due to complications from AIDS, the company's creative force, Rossella Jardini, has preserved the Moschino traditions and message in the global market, with an emphasis on trade. In 1999, ownership of the company was transferred to the manufacturer Aeffe SpA.

### Personal Image and Acknowledgments

Moschino called himself half tailor, half artist; although he did not cut or sew, he drew frequently, quickly, and spontaneously. His cuts were meticulously constructed and traditional, as well as sexy and flattering to the wearer. Yet he claimed he was in conflict with the system that produced fashion because it shamefully disregarded modern society. Moschino chose a life surrounded by mere essentials, while he provided financial support to his favorite charities, including drug rehabilitation programs and a pediatric hospice for children suffering with HIV/AIDS. In 1995, Fondazione Moschino established an organization called Smile, which offers assistance to children in developing countries.

### Clothing Designs and Artistic Hallmarks

Zany theatrics have always distinguished Moschino's memorable fashion presentations, events, performances, and happenings. He produced wildly imaginative seasonal presentations, radically changing how fashion shows are conceived. The designer once bounded on stage to interrupt a runway show, exclaiming that fashion was over, although a videotape of the show kept running, all to the bemusement of journalists and buyers. On another occasion, he displayed garments on easels and orchestrated a party inspired by the atmosphere of an open-air market. Once, he paraded models on their hands and knees down the runway, all featuring his unconventional ideals of beauty, such as a crooked nose or frizzy hair. Many Moschino models have assumed the roles of clowns, madonnas, nuns, and fairies in his unusual shows.

In 1985, a sampling of his defining silhouettes was the subject of *Italia: the Genius of Fashion* exhibit at the Fashion Institute of Technology in New York. Moschino's impassioned messages appeared printed, embroidered, and otherwise stitched on garments. The strategy behind his activism can also be regarded as an ingenious ploy to motivate the customer to buy. Advertising campaigns throughout the 1990s proclaimed "Stop the Fashion System," while the clothes were brazenly printed or otherwise appliquéd with hilarious slogans and resonant symbols, including peace signs, hearts, spaghetti stains, and bar codes. Moschino's clothing has always reflected a sense of humor together with a strong sense of social justice through words and iconic patterns such as mortar and bricks, exotic opera characters, or cowboy stereotypes. In his Ecouture line he labeled fake fur as ecological and promoted "friendly garments," colored with natural dyes, since he was concerned that dress was becoming detached from humanity and nature.

Throughout the 1990s, Moschino used an abundance of props to make statements and visual puns. In his store windows he displayed mannequins in straight jackets bearing the stenciled text "For Fashion Victims Only." He posed a regal figure regally, wearing a crown fashioned from dried macaroni, illustrating his distrust for authority. Another window featured models posed among open, suspended scissors, making scraps of glamorous materials. Once he embellished a gown with the silhouette of a duck bubbling a balloon message from its beak, "I love Fashion," and through fishnet-draped windows, Venus on a Half/Shell revealed a white bathing suit stenciled with the words "Save Our Sea." A retrospective exhibition, titled XX Years of Kaos, at the Museo della Permanente, exhibited the enterprising history of Moschino. The pages of the 1993 publication, including a video, opened with an acerbic quote describing the designer's "ten years of stupidity, fantasy and me."

The city of Milan paid tribute to the designer through an exhibition titled *Moschino Forever* in 1995. Universally recognized trademark symbols, including a cow, a heart, the peace sign, and a happy face, were placed all over the city. In 1996, the *New Persona, New Universe* exhibition featured a larger-than-life, heart-shaped labyrinth created for the occasion by the design studio within Moschino's company. This exhibition formed part of the *Biennale di Firenze*, a celebration that combined art and dress for the first time in the galleries, museums, and alternative spaces of the city of Florence, Italy. A selection of Moschino designs was included in the 1998 *Fashion and Surrealism* exhibition by Richard Martin, guest curator, at the Victoria and Albert Museum in London.

Throughout his life Moschino exhibited a remarkable ability to laugh at himself. He delighted in appropriating universal symbols, playing with them as elements of dress design, and simply having fun with fashion. He claimed fashion did not exist, and if it did, its true significance would embody the freedom to wear anything.

See also **Fashion Designer; Fashion Shows; Italian Fashion; Politics and Fashion.**

#### BIBLIOGRAPHY

- Casadio, Mariuccia. *Moschino*. Translated by Steve Piccolo. Milano: Skira, 2001.
- The Fashion Book*. London: Phaidon, 1998.
- Steele, Valerie. *Fashion, Italian Style*. New Haven, Conn.: Yale University Press, 2003.
- Mazza, Samuele, and Mariuccia Casadio. *Moschino*. Milan: Leonardo Arte s.r.l., 1997.

*Gillion Carrara*

**MOURNING DRESS** In the twenty-first century, when family funerals are private and black is worn as a fashion color, it is rarely possible to recognize that a person is in mourning. But in the past, family bereavement involved a series of highly visible public rituals. The use of mourning ceremonial and dress was originally a privilege of the royal courts of Europe from the Middle Ages and was regulated by court protocol through sumptuary laws. Over a period of five hundred years, however, the use of mourning dress spread outward to the rest of society.

#### Court and National Mourning

At royal funerals, the hearse was accompanied for burial by a vast procession of representatives of the nation's power: the bereaved family, the aristocracy, military, church, and merchants—their mourning dress carefully coded to indicate their gender and social rank. The highest in the land, both men and women, wore the longest mourning trains and hoods in expensive dull black wool, with black or white crape or linen trimmings. Lengths of mourning and details of the requisite dress followed strict royal protocol. Widows, always deeply veiled in public, wore mourning for the longest periods.

National mourning was declared on the death of a sovereign or key political figure. This indicated that black clothing had to be worn for a specific period by established society on formal occasions and whenever royalty was present. In the eighteenth century, this could be as long as a year. After the death of Queen Elizabeth the Queen Mother, on 30 March 2002, Buckingham Palace announced ten days of national mourning in Britain.

#### Eighteenth Century

Efforts to restrict the use of mourning dress to court use had to be abandoned from the late seventeenth century because wealthy European merchant families, determined to copy aristocratic etiquette, defied sumptuary restrictions, paid any fines imposed, and wore versions of court mourning dress as they pleased. Mourning dress for the wealthy became increasingly fashionably styled,

with black coats and breeches for men and mantua dresses for women, in black and half-mourning mauve.

The use of mourning dress, also for reasons of social ambition, next spread slowly to the growing middle classes. Demand across Europe thus expanded and was met through the extensive manufacture of dull black mourning wools, black and white silk mourning crapes, and jewelry. Mourning dress was made up by court and private dressmakers and tailors to suit the specific styles required by these widening consumer groups.

#### Mourning Dress 1850–1914

By the middle of the nineteenth century, the correct fulfillment of the minutiae of family mourning became a coded and very public sign of middle-class social respectability. Etiquette rules escalated. Queen Victoria, widowed at the age of 45 in 1861, wore mourning until her death in 1901. Many other widows and families followed her example, including those of the rising industrial middle classes of Europe and North America.

The weight of participation still fell heavily on widows. A respectable widow wore mourning dress for at least two and a half years after her husband died, while a widower was required only to do so for three months. Other family bereavements were mourned for specific, graduated periods.

#### Widening the Market

Another reason for this rising tide of mourning wear was its successful commercial exploitation by astute manufacturers who produced etiquette-coded goods priced to suit a wide range of consumers. Thus, from the 1840s, family-mourning dress was provided by couture salons, private dressmakers working at every social level, new department stores, wholesale ready-to-wear manufacturers, and by homemade provision. Speed of supply was essential, encouraging new and well-organized wholesale manufacturing and delivery methods. Advertising struck a balance between enticing wealthy clients and encouraging the less well off. Thus, *Myra's Journal* of March 1876 reassured middle-class customers that “these extremely cheap clothes will look and wear well, a consideration for those whose means are not unlimited.” This heavily feminized cult reached a peak between 1880 and 1900.

#### Commodification Processes

The vast array of products included widow's weeds (crape-laden bodice, skirt, and cape, with black outdoor bonnet and crape veil), indoor caps, fans, underwear, gloves, black-edged handkerchiefs, and a huge array of mourning jewelry, including black jet and “in memoriam” rings, brooches, and lockets. All of these came in three styles for use in first, second, ordinary, and half mourning. The complexities are epitomized by the finesse of descriptions for half-mourning mauve—“violet,” “pansy,” “scabious,” and “heliotrope,” none of which were to be confused with



the bright purple fashion shade of “Parma violet.” For wealthy women, all mourning dress also had to follow the seasonal shifts of fashion set by Paris. Styles thus went rapidly out of date and had to be replaced.

### Etiquette Anxieties and Errors

Advice on all of this was offered to the anxious through books and magazines. *Sylvia's Home Journal* in 1881 advised, for example, that mothers should wear black without crape for six weeks after the death of the mothers- or fathers-in-law of their married children. Aristocratic families were advised always to travel with complete sets of mourning clothes, because they might be required to wear complementary court mourning if a death occurred in any European royal family. This practice is still maintained by the British royal family.

### Altering and Making Do

At the other end of society, from the 1840s, many women purchased simpler and secondhand mourning dress. Many dyed and altered garments. Styles were modified in conformity with the less fashionable expectations of local communities. By 1900, through the growth of ready-to-wear production of women's woolen costumes, black clothing was also directed at the better-off working-class consumer. For the poorest the provision of any sort of mourning dress remained a trauma. Many, unable to afford it, even had to rely on the help of neighbors to avoid the public disgrace of a pauper funeral.

### Decline of Mourning Dress

The use of black mourning crape declined steadily from the 1880s, and by the 1930s, widows' veils were already out of use except in Catholic countries and royal circles.



### COURT MOURNING, FRANCE, FROM *ORDRE CHRONOLOGIQUE DES DEUILS DE LA COUR*, 1765

Widower for wife: total 6 months: first 6 weeks in black wool suit with deep weepers on cuffs; 6 weeks in black suit with silver buckles.

Widow for husband: total 1 year and 6 weeks; first 6 months in black wool trained robe with white trimmings; 6 months in black silk with white crape trimmings, 6 weeks in black and white.

First cousin: total 8 days of ordinary mourning—5 in black and 3 in white.

Translation from Mercier, 1877.



### FAMILY MOURNING, FRANCE, 1876

Widower for wife: total 3 months: black suit with black trimmings.

Widow for husband: total 2.5 years: 1 year and 1 day, black wool and crape; 9 months in black wool with less crape; 3 months in black silk; 6 months in half mourning.

First Cousin: total 6 weeks to 6 months: 3 weeks to 3 months in black silk; 6 weeks to 3 months in half mourning.

Translation from Mercier, 1877

After World War II, the provision of mourning dress was no longer a specific branch of the ready-to-wear industry. By the early 2000s family funerals had become so discreet that death barely interrupted the routine of life for both women and men alike. There are no longer “norms” of mourning dress—even among royalty. In 2002, Princess Anne's break with correct royal funeral etiquette was extreme and is so far unique. Taking on a male rather than a female role at her grandmother's funeral, she strode in the funeral procession behind the coffin, alongside the male royal mourners, wearing male military uniform complete with trousers and sword.

### Conclusion

The cultural functions of mourning dress as well as the styles thus varied across society. Although Fred Davis writes that “the democratization of fashion was furthered, of course, by major technical advances in the late nineteenth and early twentieth centuries in clothing manufacture” (p. 139), the widening commodification of mourning dress by 1900 in fact reinforced existing social differences through the provision of different qualities of mourning garments and the inability of the poor to afford them at all.

Mourning dress did, however, significantly influence modern processes of garment manufacture, retailing, and consumption. The need for a rapidity of supply helped found department stores and encouraged the wholesale manufacture of women's wear. It enhanced the commercial implementation of the use of sewing machines and early forms of mail order. Mourning etiquette also contributed to the development of early forms of plastic used in imitation of jet jewelry, and finally, the careful niche marketing of mourning dress contributed to the development of modern mass-advertising techniques.

See also **Royal and Aristocratic Dress**.

## BIBLIOGRAPHY

- Davis, Fred. *Fashion Culture and Identity*. Chicago: University of Chicago Press, 1992.
- Mercier, Louis. *Le Deuil, sous observation dans tout les temps et dans tous les pays comparée a son observation nos jours*. London: P. Douvet, 1877.
- Taylor, Lou. *Mourning Dress: A Costume and Social History*. London: Allen and Unwin, 1983.

*Lou Taylor*

**MUDCLOTH.** See Bogolan.

**MUFFS** The muff, a cylindrical accessory, usually furred, into which the wearer's hands are placed on either side, was called *manchon* in French, *mouffe* in Flemish, and *manicone* in Italian, and was first called snuffkin, skimskyn, and snoskyn in England. Francis Weiss cites the first mention of a snuffkin in 1483 but the earliest image is in the illustration of L'Angloyse in *Recueil de la diversité des habits*, 1567, a small tube attached to the girdle by a cord. Furs per se were not fashionable in the English or French courts in the last thirty years of the sixteenth century, but imported skins for trims and accessories had cachet, and the muff was to prove a popular means of displaying furs and status; in 1583 a skinner named Adam Blande trimmed a velvet snuffkin with five "genette skins." Imported from Africa via Italy, the genet was exotic and expensive. The quantities of skins used suggest that the snuffkins were furred inside and out.

The rich source of fur-bearing animals inhabiting colonized Newfoundland, Canada, and North America provided quantities of beaver for hats and marten, mink, lynx, otter, and fox for dress and what were, by 1601, called muffs (also a double entendre for the female genitalia). Furs provided decoration and interest, contrasting with the undecorated silks worn following sumptuary legislation controlling the use of gold decoration in fabric. In Wenceslaus Hollar's *Winter*, 1641–1644, an English lady of fashion carries a sable or marten fur muff as befits her station, decorated with a ribbon to tie at the waist: "The cold not cruelty makes her weare/In Winter, furs and Wild beasts haire/For a smoother skinn at night/Embraceth her with more delight." Not all muffs were fur, but this contrast between smooth and hairy skins belies the notion of function over fashion and the frisson of sex; Hollar's later studies of muffs show an almost fetishistic interest in the look and feel of furs. Antoine Furetiere in his *Dictionnaire universel*, 1690, defined a muff as a fur object, "originally used only by women; at present, however, men also carry them. The finest muffs are of marten, the less expensive ones of squirrel. The muffs for horsemen are of otter or tiger." Ladies would also carry lapdogs in their *manchons*. The engrav-



**Actress Ethel Barrymore with a fur muff.** Fur muffs received a revival in popularity during the early twentieth century, but were then overshadowed by the fur coat. THE ADVERTISING ARCHIVE, LTD. REPRODUCED BY PERMISSION.

ings of Bonnard and Jean de St. Jean show men of fashion carrying large muffs in lynx and otter furs suspended from the waist on a belt.

The Hudson's Bay Company was formed in 1670 and provided a supply of furs to a burgeoning middle-class consumer base. In *Mundus Muliebris*, the lady has "three Muffs of Sable, Ermine, Grey (squirrel)," from the most expensive to a cheaper but pretty fur. The rococo period saw delicate muffs in sable, skunk, squirrel, and sea otter, small and barrel-shaped or large and baglike; in 1765 William Cole noted with disapproval that in Paris "all the world got into Muffs, some ridiculously large and unwieldy." The *Gallerie des modes et costumes français* showed large muffs worn by men and women of fashion in the 1780s, one style, worn to the opera, 1784, called "*d'agitation momentanee*." More prosaic is Thomas Gainsborough's portrait of the actress Mrs. Siddons depicting a large fox muff, matching the trim of her silk mantle. As a supporter of Charles James Fox, Siddons is showing her political affiliations—as well as being fashionable. The wearers of the light dress fabrics of the revolutionary and

early nineteenth century required warm muffs and fashion plates depict ones made from bearskins. By the 1820s and the Romantic period, faux medieval muffs in ermine or the more luxurious chinchilla were imported from Chile and Peru. In the 1860s, the fur coat, the ultimate in conspicuous consumption, became fashionable and muffs were less prominent. Muffs enjoyed revivals in the early twentieth century, when Revillon stocked over a million muffs in their shops and *Vogue* wrote of chinchilla, sable, leopard, mole, ocelot, and monkey muffs (Sears and Roebuck advertised coney, meaning rabbit); but muffs were less of a focus. The all-important fur item, because fur now meant status, was the coat. During World War II, there was a brief return of the accessory, which added a touch of glamour, often reworked from an old fur. American *Vogue* described muffs in 1940, being in skunk, Persian lamb, blue fox, broadtail, mink, and leopard. The muff, however, did not survive the war. They were unsuited to modern women who drove cars, traveled on planes, lived in heated houses, and earned their own living.

See also **Europe and America: History of Dress (400–1900 C.E.); Fetish Fashion; Fur.**

#### BIBLIOGRAPHY

- De Monvel, Boutet. "What's in a Muff?" *Vogue*, 1 November 1916.
- Evelyn, Mary. *Mundus Muliebris, or The Ladies Dressing Room Unlock'd*. London: J. Costume Society, 1977. Published privately in 1690.
- Ribeiro, Aileen. "Furs in Fashion, the Eighteenth and Nineteenth Centuries." *The Connoisseur*, December 1979.
- Uzanne, Octave. *L' Ombrelle, Le Gant, Le Manchon*. Paris: A. Quantin, 1883.
- Weiss, Francis. "Furred Serpents, Snuffskins and Stomachers." *Costume* (1973).

*Judith Watt*

**MUGLER, THIERRY** Known for spectacular runway shows and fetishistic fashions, Thierry Mugler came to his career in fashion design via dance and photography. Born in Strasbourg, France, in 1948, he studied at the Lycée Fustel de Coulange in Strasbourg from 1960 to 1965 and at the School of Fine Arts in 1966 and 1967. He performed as a dancer with the Rhine Opera Ballet in the 1965–1966 season. He moved to Paris and began working as a professional photographer while simultaneously freelancing as an assistant designer for a number of fashion houses in Paris, London, and Milan. Mugler showed his first ready-to-wear collection (using the brand name Café de Paris) in 1973 and obtained financial backing to open his own company, Thierry Mugler, in 1974. In 1986 he bought out his investors to obtain full ownership of the company. He opened a fragrance company in 1990 and scored considerable success with the perfume



**Thierry Mugler, spring-summer haute couture collection, 1999.** Reflecting Mugler's use of sexual fetishism in designing fashion, this model displays a black leather outfit consisting of a halter top, mini-skirt, and choker, as well as leather wrapped around the lower thighs and knees. © PIERRE VAUTHEY/CORBIS. REPRODUCED BY PERMISSION.

Angel in 1992. In that same year he showed his first couture collection.

Mugler's characteristic style draws heavily on the iconography of sexual fetishism, and his models frequently resemble dominatrixes, from their towering high-heeled boots and corseted curves to such accessories as neck corsets and riding crops. Among his most notorious ensembles are a hot-red "cowboy" outfit consisting of hat, corset, chaps, and heels, modeled by a black transvestite, and his famous motorcycle bustier inspired by Detroit car styles of the 1950s. Mugler frequently made garments of leather and rubber, some of which make their wearers resemble giant insects drawn from science fiction. Examples of his less-theatrical outfits, such as his colorful and sharply tailored suits, were extremely popular, especially in the 1980s. As of 2004 Mugler suspended designing both couture and ready-to-wear, although he continued to produce special costumes.



See also **Costume Designer; Cross-Dressing; Dance and Fashion; Fetish Fashion; Rubber as Fashion Fabric.**

#### BIBLIOGRAPHY

- Baudot, François. *Thierry Mugler*. New York: Universe/Vendome, 1998.
- Buxbaum, Gerda, ed. *Icons of Fashion: The Twentieth Century*. New York: Prestel, 1999.
- Mugler, Thierry. *Thierry Mugler: Photographer*. New York: Rizzoli International, 1988.
- . *Fashion, Fetish, and Fantasy*. London: Thames and Hudson, Inc., 1998.

John S. Major

**MUIR, JEAN** Born in London, England, in 1928, Miss Muir (as she liked to be called) started her career at Liberty in Regent Street. She worked in sales and as a sketcher (1950–1954) at Liberty, followed by a brief spell at Jacqmar, before joining Jaeger, Ltd., as a designer (1956–1962). She was then invited to design a range of garments in woolen jersey for David Barnes, a collection that was so successful that he formed the company Jane and Jane for her (1962–1966). With her husband, Harry Leuckert, whom she married in 1955, she launched Jean Muir, Ltd., at 22 Bruton Street, London, in 1966. She described herself as a “dressmaker” and acknowledged no influences.

From its inception, the Jean Muir label became associated with virtually timeless designs that flattered but never dominated the wearer. The collections evolved subtly but remained true to Muir’s basic ethos: to create clothing that was feminine without being fussy, and classic but devoid of nostalgia. In a 1985 article in *British Vogue*, Muir stated that her style of dressmaking had been developed through an adherence to the anatomy and techniques of dressmaking:

On that, one diverts, exaggerates, pares down the lines to make the kind of shape and movement one wants. Then it’s a natural eye in terms of shape and colour, a sense of evolving while never losing sight of the structure (p. 118).

Muir’s signature fabrics were matte wool crepe and jersey, buttery-soft suede, and ultrasoft leather, which was invariably punched with small holes in decorative borders. Her fluid jersey garments were accented with precise rows of stitched or pin tucks, pleats, smocking, and shirring. Hemlines were determined by proportion rather than fashion. Although she was best known for her dark and neutral palettes, Muir was also a superb colorist. She adored beautiful buttons; for example, her tubular Perspex buttons, which were dyed to match the fabric of the garment they adorned and featured notched sides, were exquisitely restrained.

In addition to her mainline collections, Muir presented “JM in Cotton” from 1978 until about 1985 and

“JM in Wool” from 1978 to 1995. In 1986 she launched her lower-priced Jean Muir Studio line, and within this, from the early 1990s, she introduced a capsule collection of well-priced separates in washable jersey called “Jean Muir Essentials.” She was an ardent supporter of the United Kingdom’s clothing industry.

Muir shared her knowledge of fashion and design by teaching and was a vocal spokesperson for the need to raise standards in education, training, manufacture, and design. Not surprisingly, her contribution to the catalog that accompanied a 1980 traveling exhibition of her designs was an entirely practical essay aimed at students, outlining every stage of the production process. Her many honors include the following: Royal Designer for Industry (1972), Fellow of the Royal Society of Arts (1973), and Fellow, Chartered Society of Designers (1978). She was appointed a Member of the Design Council in 1983; made a Commander, Order of the British Empire in 1984; and received a British Fashion Council Award for Services to Industry in 1985. Muir was inducted into the British Fashion Council’s Hall of Fame in 1994.

Following Muir’s death in 1995, the company amalgamated the Main and Studio lines under the Jean Muir label. The label’s design team, in the early twenty-first century—Sinty Stemp, Joyce Fenton, Angela Gill, and Caroline Angell—jointly have some forty year’s experience working with Miss Muir. Since the founder’s death they have continued to evolve the line while retaining Miss Muir’s signature.

See also **Jersey; Leather and Suede.**

#### BIBLIOGRAPHY

- Bleichroeder, Ingrid. “A Certain Style: Jean Muir.” *Vogue* (U.K.), August 1995, 118–119.
- Miller, Beatrix. “Obituary: Jean Muir.” *Vogue* (U.K.), August 1995, 98–101.
- Muir, Jean. *Jean Muir*. Leeds, England: Leeds Art Galleries, 1980. An exhibition catalog.

Amy de la Haye

**MUSIC AND FASHION** The relationship between fashion and popular music is one of abundant and mutual creativity. Reciprocal influences have resulted in some of the most dynamic apparel visualizations ever created in popular culture. Some exist as memorable creations for the stage and music video; others become long-lasting fashion trends, which settle in the culture to become noteworthy, referential, and lasting.

Three collaborations exist. One is when fashion designers and entertainment celebrities engineer fashion to fit a declared project. Another collaboration occurs when youth subcultures articulate themselves through fashion. The third is when the fashion industry interprets a music-led theme or trend.

Music celebrities and designer collaborations have altered the course of fashion, though good examples of this relationship are few. The affects of these unions have been very significant. Outcomes include Jean Paul Gaultier's whirlpool corset dress worn by Madonna on her 1990 *Blonde Ambition* tour, which subsequently contributed to the trend for wearing bra tops and less clothing. Grace Jones's collaborations with the art director Jean-Paul Goude, who in the 1980s rendered Grace Jones's body a fashion object, made groundbreaking music videos and advertisements for various products. However, Grace Jones's haircut became a major trend; it became known as a "high top" when copied by young black youth.

Both Madonna and Grace Jones acted as muses for creative designers; their musical representations became reference points for widespread interpretations. The images produced by these collaborations were decisive, especially in the way they altered conceptions of traditional beauty and gestures.

The outcome of many associations of the performer and the designer or stylist is usually a confirmation of the extant youth subcultural fashion. Rather new perspectives, new methods, and new resonances of fashion are made when fashion and music are linked to subcultural expression.

Consider the partnerships of Kurt Cobain and Grunge, Marilyn Manson and Goth, and Avril Lavigne and Skater. Designer interpretations of performer and subculture expression include Jean Paul Gaultier's facsimile Marilyn Mason (Summer 2003) and Belgian designer Raf Simons's continual referencing of music-led subcultures. Simons's collections have included T-shirts emblazoned with images of the missing Manic Street Preachers guitarist Richey Edwards and a joint effort with Peter Saville, the graphic designer of Factory Records.

This article non-chronologically highlights the main collaborations since the inception of popular music. It is not a comprehensive review; Goth, Skinheads, Northern Soul, Funk, Independent Music, Rock, Grunge, Soul, Dance, and Drum & Bass cultures and collaborations are not considered. Nevertheless, it does demonstrate how innovative music and fashion expression are rooted.

### Music's Influence on Fashion

**Bobby-soxers.** With the birth of rock'n'roll in 1951, youth culture and popular culture gained impetus. In the 1940s, American teenage girls known as bobby-soxers, became famous not only for their fashions, but for their fanatical adulation of male crooners such as Frank Sinatra. Bobby-soxers wore ankle socks, hair ribbons, denim rolled-up jeans, felt poodle skirts with an embroidered and appliquéd French poodle, and blouses with small flounced edging, sloppy sweaters, and saddle shoes. Bobby-soxers were rare in music fashion cultures because males usually led most innovations.

**Mods.** The idea of intra- and inter-group identification was also important to the Mods, who formed in Britain around 1965 and had a resonant influence on fashion and menswear. They sited themselves in an urban backdrop of espresso bars, Vespa scooters, the mini motorcar, and an image backdrop of Perry Como and the French look, which was influenced by the movie *Shoot the Pianist* (1960). They wore American army parkas over imported American shirts and their suits were tailored. A small number of Mods altered off-the-peg suits or tailored their own suits. Much of the allure of Mod was that fashion designers such as Mary Quant and Pierre Cardin had the term applied to their work. Graphics symbols such as targets, Union Jacks, horizontal color stripes, and cycling images were appealing to the Mods, fashion designers, and artists. Although Mods were a fusion of teenage groups that had different interests, they were sound sophisticates who had rejected the wooliness and unhewn skiffle and trad music for the poise of modern jazz, and later rhythm and blues, blues, and bluebeat. Mods were fanatical stylist who understood that nodes of change already existed and if they connected them they would become distinct from the rest of society.

In the 1980s, the new wave band the Jam illustrated the divergence of old and new Mod. The music became trashy and aggressive while the look drew on the stereotypical apparel items that already had been diluted by other Mod bands.

During the 1980s and 1990s the legacy of Mod continued in bands such as the Style Council, Blur, and Oasis though the fashion trend had begun to assume cross-cultural references. Sojourns to Ibiza and Morocco, references to Northern soul, and 1970s Regency Mod provided the visual vitality for bands such as the James Taylor Quartet, Brand New Heavies, D'Influence, and Galliano, whose clothes fused with the "ethnicity" of Mod. The new guise, Acid Jazz, became synonymous with the urban modern menswear that included formal and sportswear items.

### Retro-Futurism and Neoclassicism

The German band Kraftwerk had underwritten the creative disposition for a number of British bands and the musical styles of Electro, Techno, and Rave. Kraftwerk were influenced by Stockhausen and Italian futurism. Their music encapsulated a metronomic electronic minimalism. Its austere, almost uniformed and metered beats defined a musical soundscape that challenged the conception of music in the way John Cage's ideas about music, noise, and silence did.

During the early 1980s Gianni Versace, Thierry Mugler, and Claude Montana used motifs that included asymmetry, stark bicolouration, and monochromatic uniformity. Fashion shops such as PX and Plaza in London were good examples of how fashion synchronizes with music.



**Grace Jones's "hightop," 1983.** A designer's "muse" and fashion trendsetter, musician Grace Jones displays her "hightop" haircut while being interviewed by nighttime television host David Letterman. © CORBIS. REPRODUCED BY PERMISSION.

Designer Anthony Price's close-fitting uniforms worn by Kraftwerk were indivisible from Price's menswear. Price's London shop, Plaza, was one of the most innovative retail concepts of its day. Price clearly referenced the Retro-Futuristic trend. From outside, neon signage was juxtaposed onto a stark white storefront, and a waist-up view of two android-like shop dummies standing behind the shop window.

These were references to Retro-Futurism and Neoclassicism that were the zeitgeists of that period. Album covers by New Order, Joy Division, and Roxy Music referenced Neoclassicism. Artists such as Gary Numan, Ultravox, and David Bowie were influenced by Kraftwerk and styled themselves in celebration of the Futurist, the Suprematist, and German and Russian Modernist.

The fashions worn by these artists varied from Numan's asymmetric all-in-one uniforms, to Bowie's mid-1970s foray in to monochromatic plain black pants and white shirt, his loose peasant shirts, pants tucked into riding boots, and exceptionally broad leather belt. Ultravox's Midge Ure captured a romantic kitsch-heroic characterization that was suitable for inclusion in a Tyrolean peasant painting by Franz von Defregger.

### Rave

Techno music was an inheritor of Kraftwerk's music. Techno became a cornerstone of British Rave in the late 1980s. Rave, a loose symbiosis of Chicago House, Electro, and Balearic Beat, started as Acid House in Manchester during 1987, which became known as the second "summer of love." The label was applied to a frenetic period that ushered in the drug Ecstasy (MDMA), the ascendant of the band the Stone Roses, and Manchester's Hacienda Club, which had become acknowledged as the center of British club culture.

Known for impromptu "happenings" at motorway service stations and on farmland, raves were notorious for the popularization of the drug Ecstasy, which became the essential accompaniment to the movement.

Techno's hypnotic digitized bleeps and sampled hooks drew diverse followers from across the social and racial spectrum. Despite an indefinable constituency, Rave began to define itself as a fashion expression.

Girls wore tight leather or denim pants, waistcoats, fitted T-shirts, and long-sleeved jerkins. Accessories included large silver rings often worn on the thumb and index finger, masses of silver bracelets, and friendship



bracelets and leather wristbands like those that hippies wore. Long, lank hair became de rigueur.

Boys were less definable, though many wore fashions by leading designers such as C. P Company, Stone Island, Paul Smith, John Richmond, Nick Coleman, and Armand Basi. Their clothes consisted of Polo shirts, T-shirts, jeans, anoraks, and reflected the current mood of menswear. Certainly, the “clubwear” designer label came of age between 1987 and 1993. However, these labels tended to be cheap, poorly made clothes, although they were perfect for Rave followers who were accustomed to wearing different clothes to “party” in each weekend. Rave personalities, such as Keith of the band Prodigy, communicated a visual sensibility that the second phase (mid-1990s onward) of Rave in Europe, America, and Britain continued. Rave’s second phase improved on the intense colorations, silly costumes, and computer graphics that had featured Rave’s first phase. Events like Berlin’s annual Love Parade, which started in 1992, and designer Walter van Beirendonck’s W&LT collection demonstrate how Rave has evolved into a lifestyle form.

### Hip-hop and Rastafarians

Occasionally fashion draws directly on music culture for inspiration. Rastafarian music has provided popular culture with an aesthetic that is applicable in a number of forms. Fashion has been a consistent interpreter of Rastafari’s fashion iconography. Fashion companies like Complice, Jean Paul Gaultier, and Rifat Ozbek have used the Rastafarian iconography such as the red, gold and green symbolism of Rastafarianism, dreadlocked hair, and khaki uniforms, in what the fashion press had called “international ethno-chic.” This term could also be applied to the collections of Owen Gaster and John Galliano who in 2000 appropriated Jamaican Dancehall and America Fly Girls as the themes for their respective collections.

The summer 2000 advertisements by the Italian fashion label “Versace Jeans Couture,” show white models wearing multiple heavy, gold neck chains, a male model wearing a stocking hat, a gold tooth, and low-slung jeans. Here the grittiness of hip-hop fashion is reconstituted, sanitized, and made accessible for the mainstream.

### New Romantics

In his 2003 spring/summer runway presentation for Dior, John Galliano referenced New Romantic personalities such as Leigh Bowery and Trojan.

The New Romantics were the most outré fashion-obsessed youth subculture London had ever witnessed. Youth subcultures tend to be motivated by class conflict and evolve fashions to counteract their position; the New Romantics lacked those anxieties. They were “Posers” who did not accept the limited propensity of glamour offered by the Punk movement. The New Romantics were led by Rusty Egan and Steve Strange, who in the late 1970s ran Billy’s—A Club for Heroes—, and later Blitz,

a wine bar in London’s Covent Garden, where they danced to Roxy Music, David Bowie, and Kraftwerk. They developed a series of looks based on romantic themes; in fact, almost any theme was possible if the wearer made the appropriate changes to create an outlandish and weird look. Dressing themes included Russian constructivism, Incroyables, Bonny Prince Charlie, Pirates, 1930s Berlin cabaret, and Hollywood starlet, puritans, and clowns, all heavily and inventively made-up. This alternative fashion expression became tangible and important once designers such as Vivienne Westwood, Stephan Linard, Helen Robinson, Richard Torry, Melissa Kaplan, Bell and Khan, and Rachel Auburn took notice. There were no references for this type of dressing, and no magazines except for *i-D*, *The Face*, and *Blitz*, which featured a review of what people wore in the clubs three months ago. The subculture became the catalyst for a number of new bands. In 1982 two new bands emerged, looking distinctly less weird than many die-hard New Romantics. Spandau Ballet and Duran Duran commercially crossed and became accepted by the radio stations, newspapers, and television as the palatable faces and sounds of New Romanticism.

### Fashion’s Influence on Music

When the British band Wham wore Katherine Hamnett’s “Choose Life” T-shirts—a prompt for self-preservation in the middle of the 1980s AIDS crisis—a subtext of protest was being enacted. This call to “revolt into style” was analogous to the Hepcat’s bewilderment about society’s ordinariness (Cosgrove 1984, pp. 77–91).

African American youth were the first to wear zoot suits and to adopt a number of bodily gestures appropriate to the wearing of a suit, which took five yards of cloth to make. The idea of the revolt into style in youth culture is well founded (Melly 1970). Interpreters of the zoot suit were the early rock’n’roll fans from America, the Caribbean, and Europe. The drape shape of the zoot suit transferred in Britain via photographs of American rock’n’roll stars on albums and other publicity, and through the West Indian migrants who arrived at London’s Tilbury Docks in 1948. West Indian migrants to Britain were mainly young people who were influenced by American movies, music, and fashion. They wore clothes that were more vivid in shape and color than anything the British had been accustomed to. Fashion and music melded together in attempts to disengage its participants from the procession of tradition. A small number of Savile Row tailors had reintroduced the Edwardian look in 1948; it became popular with young upper-class men Londoners called *Guardees*. Subsequently, working-class youth groups, the *Cosh boys* and late in the 1950s the *Teddy Boys*, began to indicate their discontent with society’s norms by adopting dandies narcissistic tendencies. They copied the style of the *Guardees* by wearing long jackets that were cut in a drape shape with velvet collars and cuffs, bright ankle socks, slim ties, and drainpipe



### REBELLIOUS FASHION

In 2001 the Belgian designer Raf Simons paid homage to the Welsh band the Manic Street Preachers. The menswear collection feature oversized shirts and sweaters adorned with marxist slogans. The manics were not the first music group to wear political iconography (the Sex Pistols wore Lenin) but Simons's adoration of the Manics and of the politics of rebellion was a first in *high* fashion. (Porter, 2001)

trousers that were similar to those worn at the time of Edward VII (1901–1910). The clothes of early American rock stars such as Bill Haley, Gene Vincent, Little Richard, and Elvis Presley drew from and exaggerated the prevailing fashion aesthetic of black America, the drape silhouette. Also from the Mississippi riverboat gambler, blue-collar worker styles that included youth culture's omnipresent blue denim jeans with rolled cuffs, leather biker jackets, biker boots, a chain, and a white T-shirt were evident. Detractors labeled the status of the rock'n'roll musicians to being outside of the mainstream and to label the fashion adoptions, music and dance moves as being aligned to “the devil.”

#### Punk

Punk rock was of the most influential and stimulating collaborations of fashion and music. It served as a pivotal catalyst for the way people in the 2000s think, create, and comment on fashion, music, and design.

Punk started in London during the 1970s and almost simultaneously became a musical genre, a fashion expression, and a way of life. Although bands such as the Slits, the Dammed, the Clash, and the Banshees were important, the Sex Pistols became the preeminent band of the genre. The fashions and the attitude of punk were on display in Malcom Maclaren's Kings Road store called Sex, and later, Seditonaries. Maclaren and his partner, Vivienne Westwood, sold clothing that was dislocated from the accepted idea of what fashion should be. The spectacle of the punk was attained by using forthright images out of context, thereby creating a distortion. Consequently, punk fashions shocked and intimidated. Punk's iconic fashion items included Maclaren and Westwood's replica of the Cambridge rapist mask, T-shirts emblazoned with corny playing card pin-up girls, homosexual cowboys, shirts with a Nazi swastika, and T-shirts of the Queen of England's face corrupted with a safety pin through her nose. All of the punk bands wore similar clothes with images that were taboo; this included

torn clothes, fetish clothes, and even clothes with simulated bloodstains.

#### Hippies

Punk was a reaction against the hippie culture, which became accepted as the pinnacle of youth rebellion.

The hippies were a 1960s folk- and rock-led movement that propagated an alternative perspective for living. According to one hippie commentator, “Hippy fashions originated from used-clothes bins, army/navy stores, and handmade clothes from scraps. In other words, whatever was cheap and available...” (New York Sun: 25, July, 2002). Clothes also originated from the Hippie trail, which passed through Turkey, Iran, Afghanistan, and Pakistan to India and Nepal.

During the 1980s and the 2000s, mainstream fashion design and rock music youth cultures adopted the hippie look. In the 1980s, the Italian designer Romeo Gigli used rich Indian embroideries and delicate prints and handwork to create soft and romantic themes that are seen in hippie dress. Marni, another Italian design company, has used the hippie theme exclusively in a brand that is elite and expensive and is therefore the antithesis of hippie ideology.

#### Fashion Catalysts

Music offers fashion more than a theme or a movement. Occasionally, a performer possesses fashion awareness that directly influences fashion.

As catalysts of fashion change (1973–1980s), David Bowie and Bryan Ferry experimented with new themes, beliefs, and values. Bowie's alter ego, Ziggy Stardust, wore elaborate costumes designed by avant-garde designer Kansai Yamamoto. The garments were not made exclusively for Bowie; they were simply part of Yamamoto's ready-to-wear collection. Bowie's fans reinterpreted the Ziggy look by wearing street clothes of the period. The ensemble consisted of high-waist pants, platform shoes, and brightly colored shirts and tank tops, which were occasionally bought from women's stores for their colors and tight fit. Ferry's various costumes included a Cosmic rocker look of a metallic leopard-skin bomber jacket and black silk trousers; the 1950s Rocker with black pants, dark blue T-shirt, and neck chain; and the lounge lizard clad in a white tuxedo, black bow tie, white shirt, and red cummerbund. He also dressed as an Army G.I., wearing khaki shirt and pants; a Neoclassic storm trooper; a gaucho, complete with gaucho pantaloons, a vest and shirt with wide sleeves and a black hat; and a 1960s soul singer, wearing a three-buttoned suit in various colors and materials, including leather and shark-skin. In many ways, 1970s disco provided exception of a music-led movement that comprehensively affected fashion. Existing at the same time as glam rock, disco had spread through much of the West. In America and Britain it had achieved the alliteration of a spectacle that fluently

## MUSLIN

contorted across the age gap and from stage to the dis-cothèque to the street.

Fashion and music proficiently and often independently create similar themes, yet the dynamic interaction between them motivates reactions that might not have otherwise occurred. The mistlike phenomenon of sub-cultural fashion holds apparel and popular music in totemic significance, creating fantastic fashion objects and moments from these restless forms. Formalized fashion is bound by an emphatic trepidation and terror. Its praxis and natural impulse is to conduct the activity of objectifying popular music, youth subcultures, and other “sexy” forms. This is why developments away from orthodox or formalized fashion customs can only be made when the agenda is no longer centered on the commerce of fashion, but is concerned with the irreverence and irrationality of making fashion images.

See also **Hippie Style; London Fashion; Punk.**

### BIBLIOGRAPHY

- Conrad, Peter. “Tommy, We Can Hear You.” *Independent On Sunday*. (30 March 1997).
- Cosgrove, Stuart. “The Zoot-Suit and Style Warfare.” *History Workshop Journal*. 18 (Autumn 1984): 77–91.
- de La Haye, Amy and Cathie Dingwall. *Surfers, Soulies, Skinheads, and Skaters: Street Styles from the Forties to the Nineties*. Woodstock, N.Y.: Overlook Press, 1996.
- Graev, Nicole. “What’s Next: MTA-Chic? Talks to the True Originators of Today’s Fashions.” *New York Sun*, (25 July 2002).
- Haug, W. F. *Commodity Aesthetics, Ideology and Culture*. International General, 1987.
- Lusane, Clarence. “Rap, Race, and Politics.” *Race and Class: A Journal for Black and Third World Liberation* 35, no.1 (July–September 1993): 41–56.
- Melly, George. *Revolt into Style: The Pop Arts*. Doubleday and Company, 1971.
- Polhemus, Ted, and Lynn Procter. *Pop Styles*. London: Vermilion, 1984.
- Porter, Charlie. “What a Riot.” *The Guardian*, (6 July 2001).

*Van Dyk Lewis*

**MUSLIN** In the early twenty-first century muslin is an inexpensive, bleached or unbleached cotton plain-weave cloth. There is no direct connection of the name “muslin” to the earlier thin silk cloths of Mosul; rather, the name arose in the eighteenth century from the French word for foam (*mousse*), which seemed to convey the feel and texture of India’s filmy cotton product. When introduced into Europe in the 1600s by the English and Dutch East India Companies, “muslin” denoted a soft, white, plain-weave cotton cloth produced in India, notably around Dacca where the constant, intense humidity eased the stress of the spinning and weaving processes on the fibers.



**Muslin dress.** This girl’s dress, featuring a simple, princess-style cut and embroidered leaf vines, is made from sheer Indian cotton muslin fabric. AMERICAN COSTUME STUDIES. REPRODUCED BY PERMISSION.

Some muslins—their degrees of delicacy graphically identified in terms of spider webs, woven wind, and evening dew—were made from particularly fragile yarns. Less ethereal versions like *mulmul*, or mull, were sometimes embellished with embroidered and drawn-thread floral designs.

The classically-inspired white muslin dresses of the early nineteenth century are well-known, but during the eighteenth century, ladies wore muslin in the form of petticoats, aprons, and kerchiefs. French reformers like Jean-



Jacques Rousseau urged parents to dress their children in unrestrictive, washable cotton clothing better suited to their ages than the customary miniature-adult styles. Girls who grew up wearing loose muslin dresses became women who considered the *ingénue* habit worth continuing—undoubtedly encouraged by Marie Antoinette’s scandalous example.

Although silks and heavier fabrics reclaimed fashion dominance by 1825, muslin continued in favor for young women’s and children’s dresses. Embroidered muslin accessories made pretty foils to mid-century wool, silk, and printed cotton garments. The first decade of the twentieth century saw a resurgence of enthusiasm for fine cotton dresses like those of a hundred years earlier—equally likely to be called muslin, mull, longcloth, nainsook, dimity, organdy, batiste, cambric, or lawn.

India muslins proceeded to undermine the dominance of domestic linen manufactures. At the end of the eighteenth century, European manufacturers were imitating the medium-weight India cottons and moving on to master fine ones. Delicate linen favorites like cambric and lawn increasingly came to be made of cotton instead, mainly because cotton was cheaper. In the 1830s the English exported striped and checked “muslin” for cheap clothing worn by American sailors who almost certainly would have disdained the dainty kind—an indication that

utility weight domestic cotton cloth was already usurping the exotic name. By the 1870s, “muslin” was being touted for ladies’ underwear, still the hard-wearing, sturdy item it had been when made of linen. Muslin has become known as a cheap, durable cloth suitable for pattern draping, upholstery, stage scenery, drop cloths and dust covers.

The world-changing influence of these imports culminated in a legacy of a few thin cotton fabrics, some of which bear names originally assigned to European linens. The once-evocative word “muslin” is now attached to an opaque, utilitarian cotton cloth that first entered the West simply designated as “calico,” a name that now specifies a fairly substantial cotton fabric printed with tiny motifs.

*See also* **Cambric, Batiste, and Lawn.**

#### BIBLIOGRAPHY

- Irwin, John, and P. R. Schwartz. *Studies in Indo-European Textile History*. Ahmedabad, India: Calico Museum of Textiles, 1966.
- Montgomery, Florence. *Textiles in America*. New York: W. W. Norton and Co., 1984.
- Paine, Sheila. *Chikan Embroidery: The Floral Whitework of India*. Aylesbury, U.K.: Shire Publications, Ltd., 1989.

*Susan W. Greene*



**NAIL ART** Beautiful nails are considered to be a precious gift to be treasured and cared for. In Greek mythology Eros is identified as the first manicurist. He cut the goddess Aphrodite's fingernails while she was sleeping and scattered them on the beaches of the earth. Seeing what had transpired, the fates collected the clippings and turned them into the semiprecious stone onyx—that is Greek for fingernail. In fact, human nails—the convex, hard horny plates covering the dorsal aspect of the fingertips and toes—have evolved from the primeval claw. In folkloric beliefs, the nails are often said to continue growing after death, temporarily evading mortal decay. Thus, long nails are characteristic of vampires, revenants, and others of “undead” status. The phenomenon is in fact due to the dehydration of the corpse which causes the skin around the nails to retract and shrink back, but the alarming effect of this particular aspect of decomposition has inspired countless morbid horror stories where sorry individuals who have been buried alive attempt to scratch their way out of the tomb. Nails, along with bones, hair, and teeth of the dead were, as Sir Thomas Browne noted in the seventeenth century, “the treasures of Old Sorcerers” and one of the oldest forms of poisoning was grated nail, which was slipped into an unsuspecting victim's food or wine. Even today people take care to disinfect a human scratch, perhaps because nails actually do contain a small percentage of arsenic.

### **The Origins of Manicuring**

The practice of manicuring is itself extremely ancient. There is evidence that as far back as 4,000 years ago, manicures took place in southern Babylonia, and manicure instruments have been found in Egypt's royal tombs. The Romans painted their nails with a mixture of sheep fat and blood. Turkish women created a pink tint for the nails from boiled rose petals. Women in biblical times not only dyed their hair but also painted their fingernails and toenails as well as hands and feet with henna juice (as mentioned in the Song of Solomon), a practice that still forms part of Middle Eastern culture today. The custom of growing long nails relates to status, since it can preclude certain forms of manual labor. Chinese noblemen and women of the Ming Dynasty (1368–1644) were well known for their extraordinarily long fingernails, which were sometimes protected with gold and jewel-

encrusted nail guards. Servants were required to feed, dress, and perform other personal chores for them so that they did not break a nail. The Chinese also used nail polish made from egg whites, beeswax, vegetable dyes, and Arabic gum.

In the Western Hemisphere colored nail polish was uncommon until the twentieth century. Instead, unstained hands with white and regularly formed nails were esteemed as part of a dominant aesthetic linking physical hygiene and moral purity. Etiquette guides from the 1800s recommend a little lemon juice or vinegar and water to whiten the nail tips and commercial products available at this time included nail polishers or buffers, crystal stones, emery boards, hand and cuticle creams, pearly white liquid, and several kinds of bleaching powders for the hands and nails. This apparent lack of adornment was an obvious indicator of wealth and enforced leisure. Emma Bovary's nails for instance are “scrubbed cleaner than Dieppe ivory and cut almond shape.” Such fastidious treatment of the nails was in keeping with the anti-cosmetics stance, which professed a belief in the transparency of inner beauty and continued well into the early 1900s.

### **The Innovation of Nail Polish**

Hollywood film did more than any other visual medium to popularize the wearing of nail polish in the West. Film actresses of the 1920s looked exotic, symbolized modernity, and flaunted nails that were painted with colorful glossy enamel that soon became commercially available. In a literal sense, the new lacquer was derived from the movies since cinematic film and nail polish originate from the same primary ingredient—nitrocellulose. One early method of making nail polish was to mix cleaned scraps of film with alcohol and castor oil and leave the mixture to soak overnight. The first tinted nail lacquers were produced in subtle shades of pink and had names like “rose,” “ruby,” “coral,” and “natural” in an attempt both to downplay the chemical origins of the product and to overcome the monochrome format of contemporary advertising.

Deep color polishes like cardinal red were unavailable until the 1930s, when Charles Revson and his partners developed a method to add opaque pigments (rather than dyes) to polish so that it would coat the nails evenly.

# "cute tomata"!

by **CUTEX**

**NEW...the FRESHEST, RIPEST RED ever Cultivated...  
Prettiest Pick for Lips and Fingertips!**

Warning to bachelors! Here comes the gayest, brightest, cutest breath of spring that ever breezed into town! It's *YOU* . . . flaunting this season's fresh and flirty new red . . . "CUTE TOMATA" by Cutex . . .

*a stop, look and whistle red . . .  
that's just your dish for spring!*

Separates by Cole of California;  
Fabric by A.R.C.;  
Look for "Cute Tomata" fashions when you shop!

Help Yourself to "Cute Tomata" . . . in  
**Chip-Pruf Cutex**, America's best-wearing nail polish, 25¢  
**Pearl Cutex**, new iridescent polish—the last word in luxury, 39¢  
**Cutex Stay Fast**, creamiest, longest-lasting lipstick ever created, 59¢  
**Cutex Duo Vanity Stand** with Pearl Cutex and Stay Fast Lipstick, 98¢.

*Prices plus tax*

Cutex brand advertisement. This "cute tomata" poster advertises a red nail color by Cutex. AP/WIDE WORLD PHOTOS. REPRODUCED BY PERMISSION.



Their company, Revlon Inc., still one of the leading producers of nail polish, became particularly famous for its legendary 1950s “Fire and Ice” advertising campaign. These ads for a range of matching nail enamels and lipsticks were groundbreaking in their use of dramatic visuals and clever text and are considered to be among the first to overtly link cosmetics with sexuality. A typical headline ran “For you who love to flirt with fire . . . Who dare to skate on thin ice.” Like much cosmetic advertising of the period, Revlon’s marketing exploited a range of connotations of nail decoration. Painted nails were part of the self-scrutinizing feminine masquerade that was dependent on male approbation, but they were also associated with increasingly liberal ideas about a pleasure-seeking modern woman.

### Nail Art Today

The last few decades have seen further innovations and fashions in Western nail art. Manufacturers have created quick-drying polishes targeted at women with active lifestyles, and the range of colors available has multiplied. From the 1980s onward brightly colored polish has been available in unusual colors ranging from ice-cream pastels to gunmetal gray, along with polishes that contain built-in decorations such as glitter or tiny metallic stars. In 1995 Chanel brought these colors firmly into the mainstream when it launched a deep black-red polish. “Vamp” continued the Hollywood connection when the actress Uma Thurman in the film *Pulp Fiction* wore it that same year. Priced at \$15 a bottle, Chanel’s polish helped to create a market for high-priced nail products and paved the way for the success of companies like Urban Decay and Hard Candy—which made huge profits from manufacturing odd experimental colors for nails. In 1998 the American Jenai Lane created “mood nail polish” which is designed to change color according to body temperature—in reflection of one’s mood.

Over \$6 billion is spent on services in American nail salons every year and the art of the manicurist has become increasingly prized worldwide. Men as well as women are now regular clients since well-kept hands are considered to be an important part of a professional image. New technologies have also resulted in more realistic-looking acrylic nails and nail extensions, which are attached with glue adhesives and glue tabs. At the fantasy end of the market, fingernails and toenails have become a natural canvas for the expression of creative imagination. Nail art is often stunningly elaborate—nails can be sculpted, stenciled, pierced, and of course painted with intricate designs. Competitions such as the Nail Olympics held annually in Las Vegas honor the art of the manicurist—as a latter-day miniaturist painter—and indicate the growing professionalization of the industry. In Britain and the United States, contemporary nail art resonates particularly with black culture. In this context elaborately painted nails are seen to offer a highly decorative alternative to Eurocentric ideals of beauty.

See also **Cosmetics, Western**; **Cosmetics, Non-Western**.

### BIBLIOGRAPHY

- Blackmore, Colin, and Sheila Jennett. *The Oxford Companion to the Body*. Oxford: Oxford University Press, 2001.
- Browne, Thomas. *Urne Buriall and The Garden of Cyrus*. Edited by John Carter. London and New York: Cambridge University Press, 1958 (originally published in 1658).
- Corson, Richard. *Fashions in Makeup from Ancient to Modern Times*. London: Peter Owen, 1972.
- Flaubert, Gustave. *Madame Bovary*. London: Penguin Books, 1985 (originally published in French, 1856).
- Mulvey, Kate, and Melissa Richards. *Decades of Beauty: The Changing Image of Women 1890s–1990s*. London: Hamlyn, 1998.
- Peiss, Kathy. *Hope in a Jar: The Making of America’s Beauty Culture*. New York: Henry Holt and Company, Inc., 1998.
- Sherrow, Victoria. *For Appearance’s Sake: The Historical Encyclopedia of Good Looks, Beauty and Grooming*. Westport, Conn.: Oryx Press, 2001.
- Tobias, Andrew. *Fire and Ice: The Story of Charles Revson—The Man Who Built the Revlon Empire*. New York: William Morrow and Company, Inc., 1976.

Katherine Forde

**NAPPING** Napping is a raised surface on a textile that is a result of brushing loose staple fibers out of the fabric structure. It may also refer to the surface texture on pile-weave fabrics. The nap makes the fabric feel softer and traps air that serves as insulation. The nap is typically brushed in one direction on fabrics such as corduroy, velvet, velveteen, and flannel. Light reflects off the surface of the fabric according to the direction of the nap and produces unique aesthetic qualities on pile-weave fabrics. This aspect is important in garment construction, because if the garment pattern pieces are not laid out correctly, the end product will appear to be constructed out of fabrics of different colors.

Napping is the finishing process that raises the fibers on a fabric to produce a mat of fiber ends, or nap. It may be used on knit or woven textiles made of staple fibers, such as wool and cotton, or with fibers cut to staple length and spun into yarns such as silk, rayon, and polyester. Napped fabrics are usually made with loosely spun yarns in the filling direction so that the fibers can easily be pulled out to form the nap. Historically, napping was done with teasels—the flower heads of thistlelike plants that have many sharp, hooklike ends. Except in the case of some fine wools that are still napped by hand, napping in the early 2000s was executed with machines that mimicked the early process. The early twenty-first century napping machines involve feeding the fabric through rollers that are covered with heavy fabric that is embedded with small, brushlike wires.

Napping can be done on one or both sides of the fabric. Napping may improve durability, hide defects, or

obscure the weave of the cloth. Napped fabrics may also have increased pilling, abrade more easily even with care, or flatten with wear. Common fabrics that are napped are wool and cotton flannel, flannel-back satin, polyester fleece, flannelette, and outing flannel. Sueded fabrics are also napped through a process that includes an additional step to shear the nap close to the surface of the fabric to produce a smooth, soft finish.

See also **Corduroy; Flannel; Jersey; Velvet; Wool.**

#### BIBLIOGRAPHY

- American Fabrics Encyclopedia of Textiles*. 2nd ed. Englewood Cliffs, N.J.: Prentice Hall, 1972.
- Emery, Irene. *The Primary Structures of Fabric: An Illustrated Classification*. Washington, D.C.: The Textile Museum, 1966.
- Gioello, Debbie Ann. *Understanding Fabrics: From Fiber to Finished Cloth*. New York: Fairchild Publishing, 1982.
- Humphries, Mary. *Fabric Glossary*. 3d ed. Upper Saddle River, N.J.: Pearson Prentice Hall, 2004.
- Kadolph, Sara J., and Anna L. Langford. *Textiles*. 9th ed. Englewood Cliffs, N.J.: Prentice Hall, 2002.
- Linton, George Edward. *The Modern Textile and Apparel Dictionary*. 4th ed. Plinfield, N.J.: Textile Book Service, 1973.
- Simpson, John A., and Edmund Weiner. *Oxford English Dictionary*. 2nd ed. Vol. 3. Oxford: Clarendon, 1989.
- Wingate, Isabel, and June Mohler. *Textile Fabrics and Their Selection*. 8th ed. Englewood Cliffs, N.J.: Prentice Hall, 1984.

Marie Botkin

**NATIVE AMERICAN DRESS.** See *America, North: History of Indigenous Peoples' Dress.*

**NAUTICAL STYLE** Nautical refers to the sea and to ships. There is a romantic image of life on the sea reflected in a navy jacket with brass buttons, a crisp white sailor's uniform, a sou'wester hat and yellow slicker, or a fisherman's sweater. All sailors and those whose occupation depends on the sea deal with the unpredictable nature and allure of the sea. Protection from the salt water, wind, and sun is a primary consideration along with allowing the mobility needed to perform the duties of their job on a ship among the ropes, nets, and sails. Historic traditions in nautical dress continue to influence modern nautical apparel.

#### Occupational Sailing

The "Jack-tar" describes a sailor of sixteenth century Europe who wore a waist-length tarred leather jacket and hat for water protection. To facilitate movement on the ships, loose breeches called "slops" and tunics of canvas or coarse linen were worn. The slops were often striped or red in color. In addition, a tar-coated canvas petticoat called a tarpaulin was often worn over the slops during

rough weather. A neckerchief and knitted woolen cap provided additional protection for the head. The tarred jacket has evolved into the classic pea coat of today, while the tarpaulin remained prevalent with fishermen through the nineteenth century.

With the birth of an official Navy uniform in England during the mid-eighteenth century, there was a more noticeable distinction between the occupational dress of a sailor and a fisherman. Blue and white with gold and silver trim for officers was the designated color palette for the Navy. This was the origination of the term "navy blue." Later in the century, American-tar wore a short blue or black-tarred jacket, cropped trousers with a knitted striped shirt, and neckerchief. Sailor hats were now made of oilcloth, a recent innovation in waterproofing that treated cotton or linen with boiled linseed oil. The oilcloth was also used in bib trousers and jackets, their yellow color serving as a safety feature for sailors who were blown overboard. A knitted wool gansey or jersey became popular during the mid-eighteenth century. These tightly knitted sweaters button on one shoulder and were patterned to represent the town of the sailor. Solid colors were reserved for naval officers, while the sailors wore stripes. The jerseys were often embroidered by the sailors with the name of the ship on the front chest.

Naval uniforms continued to evolve during the nineteenth century with the use of the sailor collar and black neckerchief that mimicked the wide collar points and black cravat worn by fashionable gentlemen. Sailors maintained variations of the blue waist-length jacket and white trousers while officers wore a gold-trimmed coat that was short in the front with tails in the back. Twenty-first-century naval officers have a white dress uniform of jacket and trousers with brass buttons and epaulets, while their service uniform is built of a navy blue jacket and pants with white shirt and black tie. The enlisted sailor wears white trousers and a tunic with a sailor collar and black tie. It is affectionately referred to as a "monkey suit" (Wilcox 1963, p. 82). Present-day commercial fishermen consider function and safety with their use of insulated layers of fleece and waterproof hooded-jackets and pants. Orange and yellow gear provides good visibility in case of a water rescue.

#### Recreational and Competitive Sailing

Traditional sailing garments have had a large influence on recreational and sport sailing apparel. Sailing as a competitive sport is marked by the first international yachting event, the Hundred Guineas Cup, in 1851, and its Olympic debut in 1896. The term yacht evolved from the Dutch "jagtschiffs," which were boats designed to chase pirates. Yacht clubs developed to encourage and support the sport of sailing. Dress for most active recreational sailors needs to provide the same function and mobility required of professional sailors. Navy blue, white, red, and yellow are garment colors associated with both pro-

fessional and recreational sailors. Navy jackets with brass buttons are a popular image, borrowed from the Navy, for the more social yacht-club member.

Traditional sailing garments have also been a popular influence for generations of children's garments. Sailor suits are a classic design for both boys and girls that began during the mid-nineteenth century when Queen Victoria began dressing her children in the style. It spread quickly through Europe and America, continuing to be a classic children's style in the twenty-first century along with the middie blouse.

### Women in Sailing

Women have historically been on shore professionally until 1942 when the U.S. Navy began to allow women to serve in positions on ships. Their uniforms were similar in style to the men's with the addition of a skirt. A 1931 *Vogue* cover shows a woman in full bell-bottom navy slacks with a red, white, and blue striped top designed for lounging rather than rough seas. A later 1956 image shows a woman on a small dinghy wearing cropped denim jeans, a white "sloppy joe," white deck shoes, and red bandanna on her head. This outfit is intended to be comfortable and functional, but designed only for good sailing conditions. Women have dramatically increased their skill and participation in competitive sailing. Dawn Riley led the first all-women's America's Cup team in 1995 and was the first female member of the winning America's Cup team in 1992.

### New Developments in Sailing

The garments worn by competitive sailors in the twenty-first century have the same requirements of protection from the elements and good mobility. However, innovative fiber and textile developments can now better protect the body, increase health and safety, and improve the wearer's sailing efficiency. Though wool has traditionally been the fiber used for insulation and water protection, apparel-layering systems take advantage of new fiber technology to help maintain the body's thermal balance. The first layer uses olefin to wick away moisture from the skin, while polyester fleece acts as an insulating layer to trap body heat. The outer-layer fabrics, such as Gore-Tex, provide a waterproof, yet breathable barrier from water and wind. The use of spandex, a fiber with stretch, in the first two layers allows for garments that fit closer to the body while allowing a greater freedom of mobility.

See also **Jacket; Military Style; Rainwear.**

### BIBLIOGRAPHY

- Cunnington, Phillis, and Catherine Lucas. *Occupational Costume in England from the Eleventh Century to 1914*. New York: Barnes and Noble, 1967.
- Lee-Potter, Charlie. *Sportswear in Vogue since 1910*. New York: Abbeville Press, 1984.
- Wilcox, R. T. *Five Centuries of American Costume*. New York: Charles Scribner's Sons, 1963.

### Internet Resources

- Naval Influences on Boys' Clothing*. Naval Uniforms and Boys' Clothing. Available from <<http://histclo.hispeed.com/youth/mil-navy.html>>.
- Olympic History: Sailing*. Available from <<http://cbs.sportsline.com/u/olympics/2000/history/sailing.htm>>.

Elizabeth K. Bye

**NECKLACES AND PENDANTS** A necklace is a form of jewelry worn suspended around the neck. It is most commonly made in flexible forms such as a chain, as a string of beads, pearls, gemstones, or other natural materials, or made of a more inflexible band of metal embellished with gemstones, pearls, beads, or other techniques such as engraving, filigree, repoussé, granulation, for example. Lengths of necklaces vary, and specific types related to extremes in length range from a short choker or dog collar necklace that fits right around the main portion of the neck to a longer neck chain or string of beads called a *sautoir*, sometimes worn hanging down to or past the waist.

As with other pieces of jewelry, the necklace has been an important site of decoration for the body but also of communication for the person. As valued material culture, necklaces communicate wealth, power, affiliation, prestige, levels of resources and skill, and elements of identity and position. The durability of jewelry like necklaces made of metal, glass beads, or gemstones provides an opportunity to appreciate and understand the technology, cultural practices, artistry, and aesthetics of other cultures and distant time periods.

A simple necklace made from a string of local organic materials such as shells, teeth, or bone beads is one of the forms of jewelry adopted by early cultures around the world. More precious materials from farther away were also valued for early necklaces, frequently in the form of beads, such as those of Mediterranean red coral found in a Neolithic burial in the Alps (circa 4200–3400 B.C.E.). Other early types of necklace included the torc or torque, an ancient Celtic neckpiece made of twisted metal, and the *lunula*, a flat, crescent-shaped and engraved variation of the torc found in Bronze Age Ireland and Scotland (circa 1800–1500 B.C.E.).

Necklaces were made to display appropriate decorative and stylistic features through each period and from region to region. Each period also has some influence upon those following, and revivals of styles, such as classical Greek and Roman necklaces or Egyptian beadwork collars, are prevalent. During the Middle Ages, jewelry became a more integral element of dress, and necklaces replaced brooches as the primary form of jewelry in the late Gothic and early Renaissance periods. Necklaces set with gemstones and heavy gold chain necklaces with pendants were in style as a distinction of wealth and social





**Remembrance locket.** The heart-shaped locket holds a small piece of ribbon from a September 11, 2002, remembrance ceremony. Lockets carry personal mementos and are usually worn for sentimental reasons. AP/WIDE WORLD PHOTOS. REPRODUCED BY PERMISSION.

status from the fourteenth and fifteenth centuries through the sixteenth and early seventeenth centuries.

Trends for wearing necklaces have for the most part followed the style of necklines in European and American fashionable dress. In other words, as necklines were lowered, more, as well as more elaborate, necklaces were seen. But this does not necessarily mean that necklaces were not worn when necklines were high. For example, a carcanet is a type of wide, bejeweled or enameled gold link necklace that resembles a collar. It was worn by men as a status symbol in the fifteenth through seventeenth centuries, encircling the base of the neck over a man's doublet and under the elaborate lace ruff, or worn with gold chains wrapped around the neck, or hanging over the shoulders down the front of bodices and doublets.

The necklace was a central piece in the eighteenth-century parure or matching set of jewelry for a woman, which also included brooch, earrings, bracelets, and a pendant or tiara. The necklace was meant to be worn as evening wear with a lowered décolletage bodice, while higher necklines of daywear included the brooch or the pendant instead. This concept of a matching set lasted through the early twentieth century until dress became more casual and when affordable but still attractive costume jewelry became widely available. New materials such as plastic and new technologies related to mass production and mass media have greatly expanded the social repertoire. Necklaces in the late twentieth century were

styled to follow both fashion and popular culture trends, but also to meet various needs for women's dress based on occasion, taste, or preference, and levels of fashionability and affordability.

Certain materials have long held reign for necklaces throughout the Western history of dress, including gold, diamonds, and pearls. The diamond necklace is one of the most expensive symbols of wealth, glamour, and prestige throughout history. Pearls were the material of choice for Roman women, and revivals of Classical period details seen in Renaissance or early-eighteenth-century neoclassical dress have included strings of pearls. The pearl was also beloved by Elizabeth I in the sixteenth century, sparking a trend for long pearl necklaces draped and pinned over elaborate stomachers. In the mid-twentieth century, the short strand of pearls became a classic gift for young American and British women on their sixteenth birthday, and it remains a popular choice for women's professional and business dress ensembles and bridal costume. The creation of imitation and synthetic diamonds and cultured pearls equalizes to some degree the concept of preciousness in jewelry and makes the look of these prestigious materials available to a wide and diverse audience today.

Both men and women throughout Western history wore necklaces until the eighteenth century, when they became primarily a feminine purview. However, American popular culture influences such as the 1960s hippie "love beads" and the 1970s disco dance craze made it more fashionable for European and American men to wear necklaces as part of popular fashion. These include gold chains, some strung with amulets or charms like the gold Italian horn or a gold cross. This trend became very prominent in the late twentieth-century hip hop music scene, when ostentatious platinum and gold chains hung with diamond-encrusted pendants displayed, as conspicuous consumption, the newly acquired wealth for African American men. Necklaces for men in certain occupations never went out of style, and higher ranks of clergy, such as Roman Catholic or Anglican bishops and cardinals have, since the Renaissance, continued to wear elaborate and expensive neck chains with large hanging pectoral crosses or crucifixes as part of their ecclesiastical regalia.

Within the broad style category of ethnic jewelry, necklaces have today transcended their original or traditional use by ethnic groups around the world and are collected and worn by European Americans of both genders as fashion or adornment regardless of, or perhaps even in reference to, their original indigenous functions or meanings. However, throughout history, the necklace as indigenous tribal or non-Western ethnic jewelry has been and continues to be a significant expression of all of the uses and meanings of jewelry outlined in this volume. In many cultures, the necklace has taken precedence over other forms of jewelry as the most important piece for adornment and communication in expressing identity or position. In addition, ethnic necklaces made from pre-

cious materials such as gold and silver, or precious organic materials like coral are frequently the repositories of a woman's or family's wealth. For example, in many nomadic cultures around the world, particularly in Central Asia, North Africa, and throughout the Middle East, heavy silver necklaces, perhaps including expensive elements such as amber or coral beads and incorporating silver coins, are portable "savings accounts" or forms of wealth and currency that could be converted to money when required. The heavy silver collar-type necklaces of the Hmong and Hmong-American ethnic group, originally from Southeast Asia and now predominantly living in the United States as political refugees, may include hundreds of silver coins and several pounds of silver metal. These necklaces serve a primary function of displaying the family's monetary wealth when worn by young women in courting rituals at Hmong New Year's celebrations. Gold necklaces, among other items of jewelry such as bangles or earrings, are purchased by women in Asia and India, for example, as their income warrants. These are put aside for future needs as investment and savings and brought out for display at weddings, for instance, especially when worn by the daughter of the family as a bride. In many instances, gold or silver jewelry is the only form of wealth that a woman may have access to. In another example, expensive Italian coral beads are collected and made into necklaces by ethnic groups in West Africa, such as the Kalabari Ijo in the Niger River delta. Worn by both men and women at ceremonial functions, these necklaces are important markers of identity but also a significant vehicle for displaying family wealth and prestige.

### Pendants

A pendant is an ornament that is suspended from another piece of jewelry such as a necklace, neck chain, ribbon, brooch, bracelet, or earring. Pendants take many forms including large gems or pearls, cameos, crosses, locket, amulets, or watches. Amulets as pendants have been most significant as one of the first forms of prehistoric jewelry. As pendants, amulets retain an unprecedented popularity in the early twenty-first century as good luck charms, as talismans, and as protection from the evil eye or any number of other perceived disasters or supernatural forces. Pendants are frequently made to be detachable so they might be used on different necklaces, or made with a pin-back so they might also be worn as a brooch.

The cross or cruciform shape is an important type of pendant in religious and amuletic categories of jewelry that has been worn since the development of early Christianity. It can carry ornamental, protective, and devotional or religious meanings. Wearing a cross can visually signify a person's religious affiliation, and different shapes of crosses can symbolize different branches or subcults of Christianity. A crucifix is a type of cross showing Christ's crucified body, worn predominantly today by religious clergy. Crosses have been made from



**Amulet pendant, Thailand.** This rectangular Thai amulet serves as a prayer box. Amulets as pendants were very popular in the early twenty-first century. © DAVE G. HOUSER/CORBIS. REPRODUCED BY PERMISSION.

various precious and nonprecious materials to suit a wide range of styles, tastes, and economic standings. Crosses in the Middle Ages and Renaissance were made as reliquary pendants to hold what was believed to be a relic of the true crucifix. In contemporary Western Christianity, small gold crosses on a chain are important gifts for a child's christening or first communion. Crosses have also been worn as charms or amulets to ward off evil or to protect the wearer from disease. For example, small gold crosses made with coral beads are worn in southern Italy today as an amulet that combines the amuletic protection of red coral against the evil eye with the symbolism of Christianity. This cross is seen as more socially acceptable than wearing the red or gold horn amulet called a *cornio*. In the late twentieth century the cross has been appropriated as a trendy sub- or popular culture motif worn without religious overtones or with a sense of defiance against its traditional symbolism. Other types of personal pendants that might be worn to signify religious affiliation include the Roman Catholic saints' medals, the Jewish Star of David, the Islamic Hand of Fatima, the Hindu Om mantra symbol, or the phylactery or amulet case worn in Jewish, Islamic, and Tibetan Buddhist religions. This last example is a small decorated metal box enclosing a prayer or scripture passage written on paper.

A locket is a small pendant in the form of a flat, round, or oval case with a hinged cover, worn usually on a neck chain or suspended from a necklace of various styles. It is worn as a sentimental piece, meant to hold a memento such as a lock of hair, a photograph, or, before the invention of photography, a miniature portrait painted on ivory. They are made from various metals and with diverse techniques, often set with gemstones and engraved or enameled. Early lockets were worn as devotional or reliquary jewelry, made in the Middle Ages and



**Edith Gould wearing strands of pearls.** Necklaces are made out of many materials, from the pearls shown here to beads and gemstones, and vary in length from the short choker to a longer strain called a *sautoir*. © CORBIS. REPRODUCED BY PERMISSION.

Renaissance to hold a saint's relic. In the sixteenth century, monarchs like Elizabeth I often presented gifts of lockets holding their portrait to favored courtiers. One famous example of a commemorative type of locket is Elizabeth's "Armada Jewel" (circa 1588) with a cast gold and enameled profile portrait of her on the front and an enameled depiction of Noah's Ark on the back, made to celebrate England's victory over the Spanish Armada. Locketts were very popular in the eighteenth and nineteenth centuries, and this continued into the twentieth after photography was developed. Nineteenth-century Victorian lockets were an important betrothal gift or sentimental gift of personal devotion. Locketts were frequently made as watchcases for men and worn suspended on a watch chain or fob.

See also **Brooches and Pins; Costume Jewelry; Jewelry.**

#### BIBLIOGRAPHY

- Borel, France. *The Splendor of Ethnic Jewelry: From the Colette and Jean-Pierre Ghysels Collection*. Translated by I. Mark Paris. New York: Harry N. Abrams, 1994.
- Evans, Joan. *A History of Jewellery 1100–1870*. London: Faber and Faber, 1970.

Gregoriotti, Guido. *Jewelry Through the Ages*. Translated by Helen Lawrence. New York: American Heritage Press, 1969.

Kuntzsch, Ingrid. *A History of Jewels and Jewellery*. Leipzig: Edition Leipzig, 1979.

Mack, John, ed. *Ethnic Jewellery*. New York: Harry N. Abrams, 1988.

Mascetti, Daniela, and Amanda Triossi. *The Necklace from Antiquity to the Present*. New York: Harry N. Abrams, 1997.

Newman, Harold. *An Illustrated Dictionary of Jewellery*. London: Thames and Hudson, Inc., 1981.

Tait, Hugh, ed. *Seven Thousand Years of Jewellery*. London: British Museum, 1986.

Susan J. Torntore

**NECKTIES AND NECKWEAR** Though the origins of wearing cloth tied around the neck lie embedded in antiquity (Chaille 2001), most scholars concur that it was the Thirty Years' War (1618–1648) that cemented the practice within European cultures. Fought between Sweden and France on one side and the Hapsburg Empire on the other, the conflict introduced French soldiers to the loose-tied neckerchiefs of Croatian soldiers, which some continued to wear once they had returned home.

Nevertheless, disagreement shrouds the etymology of the word "cravat," a derivative of the French *cravate*, which denotes modern neckties, men's scarves, and neckbows. While some sources—including the Oxford English Dictionary—make a direct link between *cravate* and *croate*, others are more circumspect, looking instead to the Turkish *kyrabâc*, the Hungarian *korbâcs*, and the French *cravache*, all of which relate to long, slender or whiplike objects (Mosconi and Villarosa 1985).

Linguistic roots aside, there is consensus that 1650 was the key point at which neckwear became a distinctive feature of western men's dress. It has been suggested that its popularity was further enhanced by a climatic factor known as the "Maunder minimum," which saw temperatures dip especially low between 1645 and 1705 (Chaille 1994).

The Battle of Steinkirk in 1692 introduced the "Steinkirk" to fashionable Europeans. Consisting of a long scarflike cravat with ends of fringe or lace that were looped through the buttonhole of the jacket (Fink and Mao 1999), it was also popular with women who would sew buttonholes into their gowns to accommodate the loose ends, or simply tuck them into the laces of their corsets (Chaille 1994). The Steinkirk had a continuing presence in portraiture long after its real-life popularity had waned, for artists such as Joshua Reynolds and Thomas Gainsborough often painted their subjects wearing the attire of their predecessors (Gibbins 1990).

By the early eighteenth century the soft flamboyance of the Steinkirk was replaced by yet another style with military origins. Popularized by French and German foot



soldiers at the end of the seventeenth century, by 1700 the stock had been adopted by civilians (Colle 1974). Originally consisting of a piece of white muslin folded into a narrow band, wound once or twice around the neck and fastened at the neck with tapes, buttons, or a detachable buckle (Hart 1998), the stock developed into a simple high collar stiffened with horsehair, whale-bone, pig bristle, card, or even wood covered in cloth (Gibbings 1990). While it did impart a stiff, formal posture, it was ultimately an uncomfortable and unhealthy style because it restricted the throat (Gibbings 1990). However, stylistic formality evolved into a softer, more decorative style when black ribbons used to tie the hair back were brought to the front and tied in a bow known as a *solitaire*, creating a contrast with the white stock beneath it (Fink and Mao 1999).

The next significant development came in the 1770s, championed by a group of young English aristocrats dubbed the *Macoronis*. Influenced by styles they had seen while travelling in Italy, they took to wearing white cravats with voluminous bows (Chaille 1994). In France, in the 1790s, young men known as the *Incroyables* (or Unbelievables) displayed their contempt for sartorial conventions by wearing clothing with exaggerated proportions, including huge cravats consisting of fabric wound around the neck up to ten times (Fink and Mao 1999).

The extravagance of the late 1700s gave way to a quest for simple elegance in the early nineteenth century, exemplified by dandyism in general and George Bryan Brummell (1778–1840) in particular. The key to “Beau” Brummell’s style lay in understatement. Though decidedly middle-class in origin, he attained an aristocratic air through an obsessive emphasis on the cut, detail, and refinement of his clothing. Immaculate, starched cravats were central to his self-presentation and he is said to have spent hours perfecting the art of knotting, pleating, folding, and arranging them (Gibbings 1990). The popularity of cravats at this time gave rise to publications that detailed ways of tying them. Published in 1818, *Neckclothitania* presented 12 styles, *L’Art de se mettre sa cravate* described 32, and *L’Art de la toilette* outlined 72.

Around the time of Brummell’s death in 1840, cravats became politicized as proponents of white cravats—affiliated with traditionalism—took on those who favored black cravats, which were associated with liberal politics (Chaille 1994). Ultimately, it was the black stock and cravat, made popular by the English monarch George IV (who reigned from 1820 to 30) that triumphed, although red ones—briefly fashionable with French and German revolutionaries in 1848—never gained much of a following in English society (Chaille 1994).

As the nineteenth century progressed, high-buttoned jackets became popular, making large, complicated cravats difficult to accommodate. Moreover, as increasing numbers of men joined the office-based workforce, few had the time to spend on the knotting and arranging of

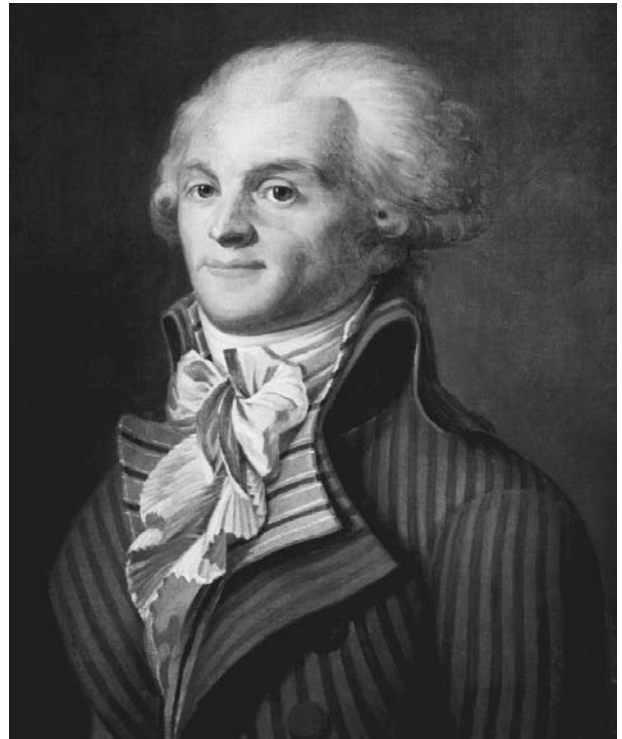

**Portrait of Robespierre wearing cravat.** In the 1770s, English and French aristocrats began wearing extravagant neck bows and voluminous cravats. The trend died out by the early nineteenth century. © ARCHIVO ICONOGRAFICO, S.A./CORBIS. REPRODUCED BY PERMISSION.

neckwear. While ready-made neckwear may have offered convenience, the higher echelons of English society remained disdainful of such practices (Hart 1998). Yet the growing diversification of the workforce, prompted by the industrial revolution, fostered a proliferation of neckwear styles by the late 1800s.

Ultimately, the cravat of the nineteenth century gave rise to four main styles: the bow tie, scarves and neckerchiefs, the Ascot, and the four-in-hand or long tie (Hart 1998). Developments in photography since the mid-nineteenth century have allowed costume historians to examine neckwear from this period onward in detail, and nineteenth-century visiting cards—often showing just the head and shoulders—have proved an invaluable resource to researchers (Ettinger 1998).

Evolving from some of the popular Regency styles, the bow-tie diminished in size so that by the end of the nineteenth century, two dominant shapes were recognizable: the butterfly and the bat’s wing (Fink and Mao 1999), both of which have an ongoing presence in men’s attire even today, but especially in the context of formal wear.

Scarves and neckerchiefs, by contrast, tend to be associated with the working classes who originally wore them out of necessity. Popular with both men and women



**Neckties on display.** A woman arranges U.S. Polo neckties at a shop in Shengzhou, China, in 2003. While not as popular as they once were, neckties are still a common sight at the office and on formal occasions. Hundreds of millions of neckties are produced in Shengzhou every year to help feed this demand. AP/WIDE WORLD PHOTOS. REPRODUCED BY PERMISSION.

and typified by a square shape folded into a triangle, scarves may be knotted in dozens of ways to protect and decorate the throat (Mosconi and Villarosa 1985).

Similar to the Gordian cravat of the early nineteenth century, the Ascot became popular in the 1880s when the upper middle classes of English society started to wear it to the Royal Ascot race and other outdoor events (Hart 1998). Initially made of plain silk, the Ascot had square-ended blades that were crossed over the shirtfront and held in place with a cravat pin. Many were sold ready-made in very bright colors (Gibbins 1990).

The long tie or vertical tie originated as young men's sporting attire in the 1850s, but became widespread within a decade (Fink and Mao 1999). More than one explanation is given for its alternative name, the four-in-hand. Some believe it to be a reference to the Four-in-Hand Club, a London gentlemen's club whose members tied their neckwear using the four-in-hand knot (Fink and Mao 1999), while others suggest that its knot and trailing ends resembled the reins of four-horse carriages driven by members of the English aristocracy (Chaille 1994). Early versions of this style of tie were sim-

ple rectangular strips of material with identical square ends that reached no lower than the sternum as waistcoats were usually worn (Chaille 1994). Practical because it neither impeded movement nor came undone, it was adopted both by workers and by the leisure classes as high, stiff collars gave way to soft, turned-down ones.

As the Victorian middle class grew and male attire became increasingly homogenous (dark, somber coat and jacket and trousers in a limited range of cuts), ties became a signpost of social status (Gibbins 1990). Evolution of the club, school, and regimental ties meant that those in the know were able to identify a man's social ranking based primarily on the color and pattern of the tie they wore. Even in the twenty-first century, some sectors of British society still believe that the stripes on one's tie define an individual to himself and to others (Sells 1998), and the expression "old school tie" persists, reflecting membership of a specific, privileged class.

Although women had worn cravats and scarves in various forms alongside their male contemporaries primarily out of coquetry (Chaille 1994), it was in the late nineteenth and early twentieth century that neckwear took

on a politicized significance. The evolution of Rational Dress encouraged women to adopt attire that not only allowed greater freedom of movement but also was essentially more masculine in appearance (Gibbings 1990). As the women's suffrage movement gained momentum, the tie—when worn by women—became a symbol of independence and feminist convictions (Chaille 1994).

Already established as the most popular form of men's neckwear in the early part of the twentieth century, the four-in-hand's success was cemented commercially by an American named Jesse Langsdorf. He improved the drape, elasticity, and wear of ties by cutting them diagonally (at 45 degrees) on the bias instead of cutting the fabric conventionally in an up-and-down direction. The process of constructing a tie from three separate pieces of material, known as Resilient Construction, was patented by Langsdorf's company, Resilio, in 1924 (Ettinger 1998). Though knitted ties, or Derbys, attained a degree of popularity in the early part of the twentieth century, Resilient Construction essentially brought the evolution of the modern necktie to a halt (Chaille 1994). Since then tie widths have fluctuated from two to five inches, although the usual width continues to be three to three-and-a-half inches (Fink and Mao 1999).

With shape and dimension more or less fixed since the 1920s, mass-production methods ensured that ties were readily available to men from all socioeconomic groups. With the onset of the Great Depression in the United States during the late 1920s and early 1930s, business slowed down; however, the widespread popularity of cinema contributed to a boom in tie sales as Americans sought to emulate their film idols (Ettinger 1998). Images of actresses such as Marlene Dietrich and Katharine Hepburn wearing ties remain some of the most iconic and memorable in cinematic history, demonstrating the potent impact of a woman wearing what had become a quintessentially male item (König 2001). In the United Kingdom, meanwhile, society figures such as the Duke of Windsor were influential, and the Windsor Knot became a popular method of tie-knotting (Chaille 1994).

As the twentieth century unfolded, variety in neckwear continued primarily through the changing use of fabric and color. Developments in textile technology, particularly throughout the 1930s and 1940s, meant that traditional fibers such as silk, wool, and cotton gave way to synthetic yarns including rayon, nylon, and polyester as they were cheaper and therefore well-suited for mass production (Goldberg 1997). Yet tie aficionados would argue that woven silk, possibly blended with wool, continues to be the most suitable fabric for a tie because of the “hand” that it gives (Chaille 2001).

Though wartime rationing in Europe during and after World War II (1939–1945) put a hold on nonessential manufacturing, in the United States, the tie market flourished with stripes, plaids, and other patterns making an appearance (Ettinger 1998). In the postwar years, how-

ever, men on both sides of the Atlantic sought flamboyance, leading to a proliferation of brightly colored ties known as the Bold Look (Goldberg 1997). Popular designs in the 1950s included those with an Art Deco influence, flower and leaf prints, wildlife themes, and “Wild West” designs (Ettinger 1998).

In the latter half of the twentieth century, ties ceased to be an essential component of everyday menswear, and were no longer seen as the definitive signifier of respectability. As youth culture liberated young men from the sartorial conventions of their parents, the tie became an occasional item to be worn at school (by girls as well as boys), work, and formal events (Chaille 2001). Having said this, distinctive styles, such as skinny “mod” ties and wide “kipper” ties of the 1960s, have earned their place in fashion history, complementing the stylistic characteristics of the suits they accompanied (Goldberg 1997). Despite a global drift toward casual dress, it seems likely that neckwear, and specifically the tie, will continue to have a presence in men's dress.

See also **Dandyism; Europe and America: History of Dress (400–1900 C.E.); Military Style; Sports Jacket.**

#### BIBLIOGRAPHY

- Chaille, François. *The Book of Ties*. Paris: Flammarion, 1994.
- . *The Little Book of Ties*. Paris: Flammarion, 2001.
- Colle, Doriece. *Collars, Stocks, Cravats: A History and Costume Dating Guide to Civilian Men's Neckpieces, 1655–1900*. London: White Lion Publishers Ltd., 1974.
- Ettinger, Roseann. *20th Century Neckties: Pre-1955*. Atglen: Schiffer Publishing Ltd., 1998.
- Fink, Thomas, and Yong Mao. *The 85 Ways to Tie a Tie: The Science and Aesthetics of Tie Knots*. London: Fourth Estate, 1999.
- Gibbings, Sarah. *The Tie: Trends and Traditions*. London: Studio Editions, 1990.
- Goldberg, Michael Jay. *The Ties That Bind: Neckties, 1945–1975*. Atglen: Schiffer Publishing Ltd., 1997.
- Hart, Avril. *Ties*. London: V&A Publications, 1998.
- König, Anna. “Tie Me Up, Tie Me Down.” *The Guardian* 31 (August 2001).
- Mosconi, Davide, and Riccardo Villarosa. *The Book of Ties*. London: Tie Rack Ltd., 1985.
- Sells, Christopher. *Ties of Distinction*. Atglen: Schiffer Publishing Ltd., 1998.

Anna König

**NEEDLES** The needle is the distinctive tool of the Upper Paleolithic period that began about 40,000 years ago. The oldest known needles with eyes date from the Gravettian period, about 25,000 years ago. The needle is one of the earliest survivors of the explosion of invention that the textile archaeologist Elizabeth Wayland Barber called the String Revolution. Paleolithic needles made of



animal bones, antlers, and tusks helped make possible the extension of human settlement into cooler regions after the Ice Age (until about 10,000 to 12,000 years ago), and they also were used for fashioning fishing nets and carrying bags. There is evidence that by the Gravettian, needles were used not only to stitch hides together for warmth but also for sewing and decorating textiles for social and erotic display. The needle was associated thus closely with humanity's new conceptual skills and expressions, including fashion itself.

Paleolithic needles had grooves rather than eyes to hold sinew or fiber. Some cognitive psychologists have suggested a progression in thought and design from the awl to the needle with an eye at its midpoint to the familiar form with a hole for the thread at the end opposite the point. It is much more likely that each form of needle, as today, was fashioned according to materials available for tools and sewing and the work to be done. Styles coexisted. Ancient Egyptians made ceramic double-pointed needles with an eye at each end; Heinrich Schliemann found six bone needles at Troy, most of them notched but one with an eye opposite the point. Roman needles were made of bronze and iron, with the eye on top.

The history of the needle reminds us of how recently the West achieved its technological lead. The medical texts of the Vedas—ancient and sacred Hindu texts first written about 3,500 years ago—prescribe straight and curved high-quality steel needles with today's familiar oval eyes and call attention to their care. While German cities had specialized guilds of needlemakers dating from the fourteenth century, the Persian theologian Ghazali, writing about 1100 C.E., praised as an example of human cooperation the division of the work of making a needle into twenty-five stages. Spain inherited the secrets of Islamic steel needlemaking; refugees brought these skills to England. Even in the London of Henry VIII (r. 1509–1547), the only needlemaker who could draw his own steel wire was a Spanish immigrant. Other masters imported coils from Germany and Spain. Needles were among a household's valuables, protected in special cases that women attached to their belts. Only in the eighteenth and nineteenth centuries did large needlework boxes become common, even among the affluent.

Between the death of the London master in the sixteenth century and the publication of the *Encyclopédie* in the eighteenth century, British and French needlemakers made great but largely undocumented progress in their craft. Needles were supplied for many trades outside of fashion and medicine, including clock making and goldsmithing. To escape guild restrictions on machinery in the seventeenth century, many needlemakers relocated to Redditch, England, in the Midlands, where the industry has remained ever since, with ample water power (from the Red Ditch that gave it its name) and proximity to both metalworkers and crafts using needles. While the *Encyclopédie* of 1762 illustrates a variety of stages in a single

workshop, the Redditch industry remained a network of families, each specializing in one or more stages of the process.

Eighteenth-century needlemakers developed a system of production that is still the basis of today's automated factories. (Surgical needles are still made by hand.) Steel was heated, shaped into a cylinder, and drawn through a number of dies to achieve the proper gauge, then cut into needle lengths. The end was hammered flat, the wire heated, and an eye punched and—often—grooved for easier threading; then the eye was filed smooth and the other end sharpened by filing. The needles were hardened by heating and cooling, then tempered for strength and straightened with a hammer and anvil. Up to 15,000 needles were polished by enclosure in a bag with emery dust and olive oil—a package moved back and forth between planks under a heavy weight for as long as two days—after which they were washed with hot water and soap and dried in a bran-filled box, then sorted and repointed manually with an emery stone. The water-powered scouring mills of Redditch produced such an excellent finish that the town attracted most of England's needlemakers.

During the eighteenth century, workshops grew as the operations were divided among workers of different skills. Craftsmanship may have reached an all-time peak in supplying needles for the finest embroidery and other luxury work. The Forge Mill Needle Museum in Redditch has needles from the time with hand-punched eyes so small they are visible only with a magnifying glass. Thread fine enough to pass through them is no longer made, except for some specialized sutures.

In the early industrial revolution, needle workers were both aristocrats and casualties. In the final stage, a pointer held up to 100 needles at a time against a grindstone and could finish as many as 10,000 an hour. If a grindstone broke and flew apart, it could be fatal, but the most serious threat was inhalation of tiny particles of stone and metal, which caused Pointer's Rot, an occupational pulmonary disease. Surviving pointers—their life expectancy was under thirty-five years—earned a guinea a day, and long resisted not only mechanization but also dust exhaust equipment that would have reduced their wages as well as their mortality. Nor were risks limited to the needle workshops and factories. To inhibit rust, eighteenth-century needles were (at least in France) sometimes packed in asbestos powder before the mineral was known to cause lung cancer.

The nineteenth century was the golden age of needle production. Higher disposable incomes, the new profusion of textiles, the introduction of the sewing machine, and the rise of world trade with the steamship and the British Empire all expanded markets as new machinery expanded capacity. The rule of thumb was that a nation bought three to four hand-sewing needles per year per household. Needles were now cheap enough to be lost

in great numbers. By 1906, *Scientific American* reported an annual production of 3 million needles per day worldwide, with 300 million purchased each year in the United States alone. Most hand-sewing needles sold in the United States were British-made; Americans never attempted to challenge British dominance of needlemaking.

The needle industry shared the nineteenth century's enthusiasm for variety and details of finish, including gold-plated grooves. Tailors, seamstresses, and home sewers could choose from twelve sizes of "sharps," the most common style, which generally had grooved eyes to keep protruding thread from damaging fabric. There were also nine sizes of "blunts," short and thick needles for fast, uniform stitching by tailors, and a range of "betweens." Crewel needles had larger holes for stranded thread, and other styles were designed for easier work with other yarns and fabrics. For most styles and sizes there was also a range of quality and packaging. On better grades, grooved eyes were gold plated.

Threading (along with corrosion and injury risk) has long been the Achilles heel of needle design. Major nineteenth-century patents attempted to substitute tactile cues for visual hit-or-miss. The Calyx-Eye was open at the top, with two angled prongs that yielded temporarily to gentle pressure on the thread but retained it securely thereafter. Other innovations, like the Eigo and the Filtenax, guided users in threading from the side of the needle or opening the top with the thumbnail. "Primary" needles extended ease of use to schoolchildren, as sewing was still an essential skill for girls of all social classes.

At its peak in the late nineteenth century, the Redditch needle industry was producing fully 90 percent of the world's needs. But challenges were growing. German needlemakers began to assert technological leadership as early as 1850, when the Schumag company of Aachen introduced a machine that stamped and eyed needles in one operation. Even in the early 2000s, German manufacturers dominate sewing machine-needle production. With their concentration on hand sewing, British producers were also hurt by the skill's decline in the household and the school curriculum later in the century, and the factories that British firms built abroad during the empire to serve local needs with inexpensive labor have more recently come back to haunt these firms' successors with low-cost imports. Over generations, the Redditch industry has consolidated into a handful of firms producing premium hand-sewing needles for the world market.

While much of needlemaking has been a mature industry for over a century, the technological frontier continues to move in heavy industrial sewing, where stronger thread and faster machine speeds can heat needles to the point that thread and fabric are damaged. Textile engineers have been using computer models to predict these problems, and their studies are likely to lead to innovations not only in sewing procedures but in the metallurgy, production, and geometry of industrial sewing needles themselves.

See also **Pins; Sewing Machine.**

#### BIBLIOGRAPHY

- Dennell, Robin. "Needles and Spear-Throwers." *Natural History* 90, no. 10 (October 1986): 70–78.
- Gloger, Jo-Ann, and Patrick Chester. *More to a Needle than Meets the Eye: A Brief History of Needlemaking, Past and Present*. Redditch, U.K.: Forge Mill Needle Museum, 1999.
- Rollins, John G. *Needlemaking*. Aylesbury, U.K.: Shire Publications, 1981.

Edward Tenner

**NEHRU JACKET** The Nehru jacket worn by men in the United Kingdom, United States, and Europe differs from the upper-body garments worn by Jawaharlal Nehru, independent India's first Prime Minister (1947–1964), after whom the Western garment is named. The Nehru jacket is similar to a Western man's tailored suit jacket, but with a difference. The collar and lapels are replaced by a front-button closure rising to a high, round neckline surmounted by a narrow stand-up collar. The stand-up collar may be cut with a slight curve to set it into a well-cut neckline, evidencing the transformative effect of Western tailoring on the Indian men's collar from which it is derived. When popular in the late 1960s and early 1970s, the Nehru jacket was paired with trousers and one of several choices for shirts—turtleneck, mock turtleneck, or tunic. The design of the jacket facilitated the display of bead necklaces, a new element in the dress of male youth in that period.

The eponymous upper-body garments worn by Nehru during his public life are three in number: a *kurta* (tunic), and worn over it a *bundi* (vest) in summer or an *achkan* in winter, variously also called *jama* in Indian languages, and in Colonial English, *Pharsi-fashion coat*, or long coat (Ghurye 1996, pp. 168, 176, 188). Each of the three sports a stand-up collar atop a front-button closure, though kurta collars are optional.

In most other respects Nehru's Indian garments differed significantly from the Nehru jacket of Western men's fashion that they inspired. The kurta is a cotton or silk shirt with a broad flowing A-line silhouette, side slits, uniquely Indian inseam side pockets, inset long sleeves, stand-up collar, and a front-buttoned placket that reaches down to the wearer's lower chest. Nehru wore his kurta at below-knee length, ensembling it with *churidar payjama*—a bias cut, drawstring waist pant cut narrowly over the leg from knee down to ankle, with additional length added to the garment so that the fabric forms gathers at the ankle, mimicking the narrow *churi* glass bracelets that Indian women wear on their wrists. The churidar payjama is the ancestor of jodhpur riding pants.

Nehru's Indian bundi is a front-buttoned, high hip-length sleeveless vest with stand-up collar and three front pockets—two below and one above. It is made from cot-



**Nehru with U.S. President Nixon and the First Lady.** As Nehru gained prominence on the world political stage, his Indian long coat took on more Western design features, such as the besom breast pocket and vented buttoned cuff. It did retain the distinctive Indian features of A-line silhouette, below knee length, side seam slits, in-seam pockets, front buttoned closure to the neck, and standup collar. AP/WIDE WORLD PHOTOS. REPRODUCED BY PERMISSION.

ton, silk, or wool *khadi* (homespun) fabrics. Nehru wore his bundi with a knee-length kurta and churidar payjamas.

Nehru's long coat extends below the knee, and has a front opening down through the hem but closed with buttons only from neck to waist; stand-up collar; and inset long sleeves with straight hem at the top of the hand. Unlike the aristocrats of pre-Nationalist Indian society, Nehru made his long coats from khadi fabrics, abstaining from the luxurious silk and gold brocades (*kimkhabs*) from which the Indian nobility usually made theirs. The long coat is worn with a kurta and churidar payjamas, with all its buttons closed, presenting a very finished look.

The manner in which the Western men's garment gave up its lapels and took on the stand-up collar and "Nehru jacket" name is a history of global dimensions in fashion and politics that begins before Nehru was born. Both the long coat and the kurta gained their style of inset sleeves and the kurta gained its front-button placket under European and British colonial influence. Long coats also became more tailored under the British, both during the early colonial era and, after a hiatus of rejection of western dress influence during the independence struggle, as the public officials of the new nation took their places on the global political stage.

Nehru came into public consciousness in Britain from the early decades of the twentieth century during India's long political struggle. In the United States, popular attention focused on Nehru from the mid-twentieth century, when in 1962 China attacked newly independent India. U.S. leaders courted Nehru and Pakistani leaders as allies against the spread of communism. Nehru visited Presidents Truman, Eisenhower, and Kennedy in 1949, 1956, and 1961, respectively. Jacqueline Kennedy visited Nehru in 1962. As Americans watched the first lady's dress, they also learned what Nehru wore.

Experimentation with and rejection of suit dressing for men (Bennett-England 1967) was occurring in Western fashion during this same political period. Cinema idols, such as Marlon Brando, appearing in T-shirts and black leather jackets, popularized nonsuit dressing and valorized the classes of men who could ill afford the expense of suit dressing. Inspired by advances in space travel, Pierre Cardin offered his Space Age line in 1964. The most influential piece was his collarless, lapel-free suit jacket (McDowell 1997, pp.144–145). It buttoned all the way up the front ending in an unadorned round neckline that revealed the collar of a dress shirt. Though not widely accepted, Cardin's garment found favor with the Beatles and other early 1960s British rock groups who wished to remain respectable through suit dressing, but wanted to cut an independent image. While collarless suits gained only limited popularity, Cardin's rejection of vestigial aspects of men's dress encouraged further experimentation with the suit jacket, such as the use of innovative fabrics like denim and velvet, or bright colors and prints for men's suits. A general narrowing of the entire men's suit—leg, torso, sleeve, lapel, and its accompanying necktie—also occurred. This fashion threatened to make parts of the suit disappear. It simultaneously made the suit even more uncomfortable to wear. Formal dressing in tunics à la Yves Saint Laurent and others provided nonsuit alternatives for formal male attire. After the release of the Beatles' *Sgt. Pepper's Lonely Hearts Club Band* album, stand-up collar military uniforms as featured on the album cover—with or without gold braid—as well as second hand navy pea jackets (double-breasted with lapels) became an additional popular alternative to suit dressing for youth. Within this climate of broad attack on and experimentation with suit dressing, a new type of designer arose in Britain to serve the youth who were its primary proponents in dress practice. These British boutique designers offered innovative clothing in successions of quick fads popular among youth.

The Nehru jacket appeared as one of these brief fads after George Harrison and the Beatles went to India in 1966 to learn meditation and music. They brought into fashion not only Ravi Shankar's sitar music and incense, but also paisley prints, bead necklaces (originally Indian meditation beads) for both men and women, Kolhapuri sandals, white-on-white Lucknow *Chikan* embroidered cotton kurtas, and the stand-up collar of the Nehru jacket.



Whether worn on a vest or jacket, the stand-up collar joined in the general experimentation with men's suit dressing. Marly (1985, p. 134) reports Simpson's of the United Kingdom offered a velvet lapel-free suit with Indian style stand-up collar in anticipation of a popular market they forecast with the opening of the movie *The Guru*, in 1969.

American youth were not as cognizant as British youth of Nehru and India, but they were very involved in British popular music. The Nehru jacket crossed the Atlantic and was briefly worn in the United States, too. Several entertainers, including Johnny Carson and Sammy Davis, Jr., made it a regular part of their wardrobe. However, military-style stand-up collar jackets were also redesigned and worn by youth in this period. Not all stand-up collar jackets from this period strictly trace their origins back to India via Nehru or the Beatles.

Though considered a short-lived fad on both sides of the Atlantic among sectors of Western society deriving from European roots, the Nehru jacket has achieved classic status in those sectors of global society—especially British Commonwealth countries—with significant Indian diasporas. Their tuxedo-rental agencies now routinely provide Nehru jackets with matching suit trousers as one of their options for formal attire. Conversely, the several garments that Nehru wore remain in fashion among urban upper- and upper-middle classes in India for bridal and special occasion wear. The humbler versions of these garments also continue in use in the regions of rural India whence they originated.

See also **India: Clothing and Adornment; Sports Jacket.**

#### BIBLIOGRAPHY

- Bennett-England, Rodney Charles. *Dress Optional: The Revolution in Menswear*. London: Peter Owen, 1967.
- Ghurye, G. S. *Indian Costume*. 2nd ed. Bombay, India: Popular Prakashan, 1966.
- Marly, Diana de. *Fashions for Men: An Illustrated History*. New York: Holmes and Meier, 1985.
- McDowell, Colin. *The Man of Fashion: Peacock Males and Perfect Gentlemen*. New York: Thames and Hudson, Inc., 1997.

Hazel Lutz

**NEW LOOK** The New Look was the name given to a style of women's clothing launched by Christian Dior in his first haute couture collection presented in Paris on 12 February 1947. The styles that made up the look corresponded, according to the show's program, to the shapes "8" and "Corolla," respectively described as "clear, rounded, bust emphasized, waist indented, hips accentuated," and "dancing, very full-skirted, tight-fitting bust, and narrow waist" (Musée, p. 131).

At the end of the show, Carmel Snow, editor in chief of *Harper's Bazaar*, is said to have inadvertently named



**Women model Christian Dior dresses.** Dior's New Look designs drastically lowered hemlines and emphasized the body's contours, frequently utilizing heavy, multilayered fabrics. AP/WIDE WORLD PHOTOS. REPRODUCED BY PERMISSION.

the style by saying to Christian Dior: "Your dresses have such a new look" (Cawthorne, p. 109). The English term was then adopted without translation by the designer himself and by many commentators in the form "New Look" or "New-Look." Christian Dior used it to define his own style between 1947 and 1952: "1952 began in solemnity ... the euphoria of the New Look was finished" (Dior, p. 178–179). However, the term is more broadly applicable to all the creations inspired by Christian Dior's first collections, both his own and those of his famous or anonymous imitators. This is true regardless of the date. The New Look, a watchword in the 1950s, particularly in haute couture, had striking stylistic repercussions at least into the 1960s. It was not until 1970 that Yves Saint-Laurent dismissed the style as a thing of the past with his fall-winter 1970–1971 "Liberation" haute couture collection that celebrated the aesthetic of the World War II years that the New Look had fought against. Thereafter considered a historical style, it still inspires contemporary work that periodically quotes it (Jean-Paul Gaultier in particular) or pays it true homage (Yohji Yamamoto, "homage to French couture" collection for spring-summer 1997).

The New Look had multiple origins: the collections of the period immediately before World War II already hinted at a return to fullness in Balenciaga, Mainbocher, Lelong, and Piguet, which returned beginning in 1946; theater and film during the war revealed a clear taste for the Belle Époque and long dresses in general. The basque created by Marcel Rochas in 1942 finally opened the way to emphatic stylization of the torso. But Christian Dior was responsible for the formal, structural, and stylistic definition of the New Look, and for its economic and social impact.

In terms of form, the New Look was constructed with reference to the individual garment as a reaction against wartime style. The voluminous and composite hats in fashion in Paris under the Occupation were supplanted by those with a “deliberately simple” silhouette (Musée, p. 131). Broad shoulders were replaced during the day by the sloping profile of raglan sleeves, and in the evening by bustiers. The loose-fitting style was rejected in order to reveal the structure of the breasts.

The waist remained fitted, very often belted, to emphasize the contrast between the new width of the hips and the flare of the skirts that, “definitely lengthened” (Musée, p. 131) in the spring of 1947, and by the following fall “reached unlikely dimensions and this time went down to the ankles” (Dior, p. 49). From the spring 1947 collection, the history of fashion has preserved the styles of the “Bar” suit and the “Corolla” dress as manifestos of the New Look, reminding us that the style affected suits constructed by tailors as well as looser garments draped by dressmakers.

For the wardrobe, the New Look marked the triumphal return of the long evening dress, which the war had replaced with short formal dresses. By restoring very visible gradations between daytime clothing and evening dress, the spotlight thrown on evening gowns lastingly reestablished the fashionable dress code.

Structurally, the New Look was built on choices of material and technical procedures aimed at sculpting contours: “I wanted my dresses to be ‘constructed,’ shaped on the curves of the feminine body and stylizing those curves” (Dior, p. 35). Fabrics were chosen for their solidity, accentuated by lining them with percale or taffeta. In 1952, for example, *Harper’s Bazaar* saw the “Cigale” style as “a masterpiece of construction” and described its watered ottoman fabric as “so heavy that it looks like pliant metal” (Martin, p. 107). Dresses were conceived as multilayered compositions supported by underpinnings, including underwired bustiers and tulle and horse-hair skirts. The body itself was, if necessary, artificially shaped by the use of girdles and basques, or by recourse to flattering padding. These artifices, modifying shape as well as bearing, characterized the fashion of the 1950s with an ultra-feminine and affected aesthetic.

In counterpoint to the tendency toward simplification and lightening, which sums up the evolution of fash-

ion from the 1910s to the 1940s, the New Look seemed in 1947 to be an anachronism. Of his second collection (fall-winter 1947–48), even more emblematic than the first, Christian Dior conceded that the “sumptuous fabrics, velvet and brocade, were heavy, but who cared!... Abundance was still too much of a novelty for people to reinvent a snobbism of poverty” (Dior, p. 49).

Considered backward-looking and extravagant, the New Look offended popular sensibility in the immediate postwar period. While the French press was indifferent or favorable to the style, it found enthusiastic support in the United States (*Life*, *Vogue*, *Harper’s Bazaar*). For his very first collection, its creator was given the Neiman Marcus Award, indicating the serious commercial involvement of American buyers. A segment of the Anglo-American press, however, conducted a kind of populist anti-New Look campaign. Leagues were established in the United States against the lengthening of skirts, such as WAWS (women at war against the style) and the “little below the knee club.” In England, the opposition took on a political flavor: “The long skirt is a caprice of the idle rich” (Braddock, Bessie, quoted in Steele, p. 20). These unexpected repercussions of the New Look testify to the rigor of clothing restrictions during the war. Imposed more or less drastically as part of the war effort on the American and English populations in order to contribute to victory, privations were experienced in France as despoilment by the occupying forces and had nothing of the character of patriotic sacrifice. The postwar period saw the victory of the independence of the New Look over the morality of the allies. Both liberating and respectful of custom, the style surprised and comforted bourgeois conventions. Thus, it quickly made headway in all social circles in Latin and Anglo-Saxon countries to become an international style, the popular interpretation of which was summed up in the ensemble of pleated skirt, belt, and blouse. Its diffusion was then the consensual expression of the construction of a new transatlantic social order on the ruins of European urbanity: “If I dare to refer to the style of 1947, which was called the New Look, it was successful only because it fit in with a time that was trying to escape from the inhuman in order to rediscover tradition” (Musée, p. 14).

See also **Dior, Christian; Haute Couture; Paris Fashion.**

#### BIBLIOGRAPHY

- Cawthorne, Nigel. *Le New-look / la révolution Dior*. Paris: Celiv, 1997.
- Dior, Christian, ed. *Christian Dior et moi*. Paris: Amiot-Dumont, 1956.
- Martin, Richard, and Harold Koda. *Christian Dior*. New York: Metropolitan Museum of Art, 1996.
- Musée des Arts de la mode. *Hommage à Christian Dior 1947–1957*. Paris: Union centrale des Arts décoratifs, 1986.
- Remaury, Bruno. *Dictionnaire de la mode au XX<sup>e</sup> siècle*. Paris: Éditions du Regard, 1994.

Steele, Valérie. *Se vêtir au XXème siècle*. Paris: Adam Biro, 1998.  
 Veillon, Dominique. *La Mode sous l'Occupation*. Paris: Payot, 1990.

Eric Pujalet-Plaà

**NEWTON, HELMUT** Helmut Newton (1920–2004) was arguably the single most inventive and influential photographer working in the realm of fashion in the second half of the twentieth century. Yet it would be selling him short to label him a fashion photographer. While he proved himself a master at this métier, his talents went far beyond the eloquent depiction of fashionable clothes. Newton's oeuvre constitutes a richly layered document of social and cultural history, intensely personal, often autobiographical, but always engaged with the world as he saw and knew it. Newton's curiosity was wide-ranging and insatiable. Within the sphere of fashion, he was instrumental in greatly extending the possibilities of what a magazine editorial photograph might be, as he wove into the equation the subtexts of his endless fascination with women and the way they lived, with status and power, and with the environments and protocols of the rich and sophisticated people who were his principal subject matter. And of course he injected sex into the mix, exploring the often-perverse erotic codes and narratives that are as integral to the processes of fashion as to life itself.

### Photographic Style

Helmut Newton became an exceptional social anthropologist, constructing images that were always based on his close observations. His was a documentary project that involved reconstructing the essence of what he had seen, and doing so with the mordant wit of a satirist. While his pictures can have a theatrical extravagance of gesture or context, their incisiveness, credibility, and substance derive from their being always grounded in the realities of the worlds that he illustrated. Newton was not happy working in a studio. Like the photojournalists or documentary photographers he admired, like his heroes Dr. Erich Salomon or Brassai, he found energy and inspiration in the world around him, on the streets, in hotels, in parks, on trains. He greatly respected the paparazzi, valuing the immediacy and energy in their way of working. Newton created a unique meld of cool, polished stylishness with authentic frontline reporting. His pictures are carefully prepared, minutely controlled and crafted, with every detail of hair, makeup, props, and accessories meticulously overseen, but they work because, however contrived and extreme, they are ultimately believable.

### Early Experiences and Influences

Helmut Newton was born in Berlin into a Jewish family that enjoyed the prosperity generated by their button-manufacturing business. The pampered child of loving parents, Newton enjoyed a charmed childhood, from which date his tastes for grand cars and hotels, for elegant

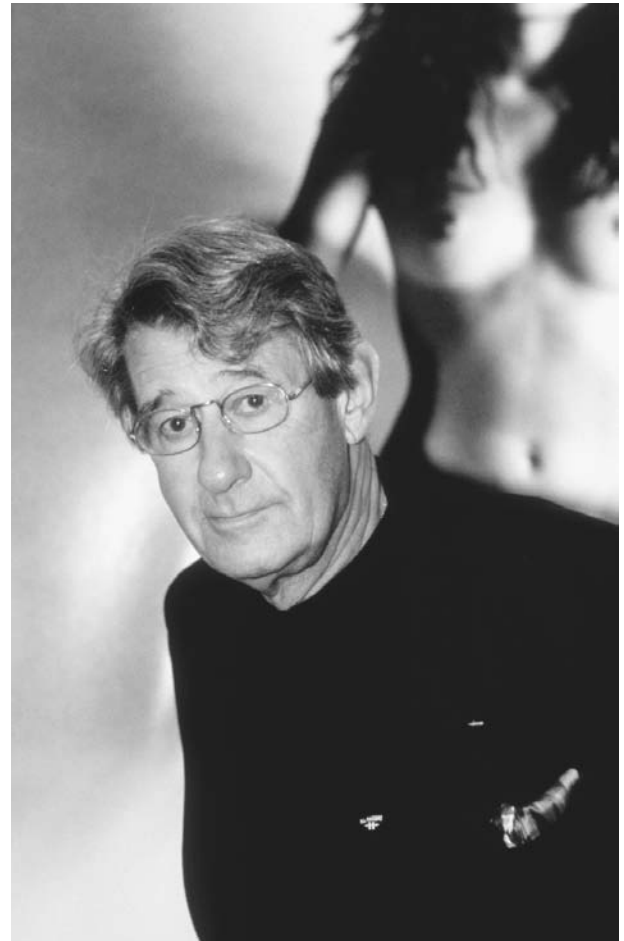

**Helmut Newton, 1995.** Renown for his erotic black and white photography, Helmut Newton's career garnered fans, critics, and controversy. © SIEMONET RONALD/CORBIS SYGMA. REPRODUCED BY PERMISSION.

fashions and other symbols of the privileged lifestyle of the old European bourgeoisie. His youthful passions were swimming, girls, and photography; he single-mindedly turned these interests into a way of life. He had little interest in academic studies and eventually persuaded his parents to allow him to abandon school in favor of an apprenticeship in the portrait and fashion studio of the Berlin photographer Yva (Elsa Simon). Newton's idyllic Berlin years were undermined by the rise of the Nazi party and the incremental persecution of Jews. In due course he had no option but to flee. Leaving his family and home in December 1938, he sailed for the Far East. He spent time in Singapore where he worked briefly, but unsuccessfully, as a photographer on the *Straits Times* and lived self-indulgently as a gigolo. In 1940 he made his way to Australia. After the war Newton set up a studio in Melbourne and worked hard towards his ambition to live by his photography. In 1948 he married June Browne, an actress he met when she visited his studio looking for modeling work.



June played a crucial role in Newton's life through more than fifty years, supporting, encouraging, editing, and protecting her husband.

Occasional assignments for the Australian supplement to British *Vogue* led to an invitation in 1957 to work for a year in London. Newton was unhappy there and found Paris far more to his liking. Work for *Jardin des modes* provided his first involvement with the world of Paris fashion. He returned to Melbourne to work for Australian *Vogue*, but he knew his destiny was to work in Europe. The big opportunity came with the offer of a contract from French *Vogue* in 1961, and his return to Europe at this date marks the beginning of his mature career. This relationship between Newton and French *Vogue* lasted until 1983. "For twenty-three years," he has said, "I did my best work for French *Vogue*." He created some of his most celebrated and admired images—such icons as the androgynous model in a Saint Laurent trouser suit in the rue Aubriot at night (1975), *Sie kommen*, naked and dressed (1981), or the first *Big Nudes* (1980)—for this magazine. Newton lived to work, and he made fashion pictures at every opportunity for numerous other magazines besides French *Vogue*, including *Elle*, *Queen*, *Nova*, *Marie-Claire*, and *Stern*.

### Mature Work

If the 1961 French *Vogue* contract was a turning point, so too was an unanticipated trauma ten years later. In 1971 Newton suffered a major heart attack on the street in New York. Medical assistance was close by and he recovered, but he was severely shaken by this brush with death and determined from that moment not to waste a single day of his life. He knew he must abandon any inhibitions and concentrate on making only the pictures that he wanted to make, pushing his ideas and instincts to the limit. From this time on, he extended his range to include what he at first called his *portraits mondains* and his *sujets érotiques*. He proved himself immensely skilled in probing the boundaries of acceptability and in creating the strange mood of disquiet that pervades his pictures. Newton drew on his memories of the Weimar Berlin of his childhood and on his nostalgia for prewar Europe. He flirted with the pornographic, challenged conventions, and created a provocative, hybrid photography that embraced fashion, erotica, portrait, and documentary elements, producing a highly stylized exposé of elegant and decadent ways of life. Newton turned his attention to making powerful, confrontational nudes. He conceived witty, erotic picture stories for the American magazine *Oui*, and he gave his unique twist to the creation of pictures for *Playboy*.

Newton's portraits of celebrities became an ever-more important aspect of his work, and while these were at first mostly related to the worlds of fashion, over the years he broadened his portfolio to include countless people who intrigued him—artists, actors, film directors, politicians, industrial magnates, the powerful and the

charismatic from all spheres. Many of these photos were published through the 1980s in *Vanity Fair*.

Newton staged his first one-man exhibition in Paris in 1975. The following year he published his first book, *White Women*. Over the next twenty-five years he worked steadily and productively, publishing a series of books and creating countless exhibitions, the most impressive of which was surely the large-scale celebration of his career at the Neue National Galerie in Berlin on the occasion of his eightieth birthday in 2000, accompanied by the simply titled book, *Work*. His last major project before his death in 2004 was the planning of a foundation devoted to preserving and promoting his archive and that of his wife in his native Berlin.

See also **Fashion Magazines; Fashion Photography; Vogue.**

### BIBLIOGRAPHY

- Blonsky, Marshall. *Helmut Newton: Private Portraits*. Shimer/Mosel, 2004.
- Felix, Zdenek, ed. *The Best of Helmut Newton*. New York: Thunder's Mouth Press, 1996.
- Newton, Helmut. *Autobiography*. New York: Nan A. Talese/Doubleday, 2003.
- . *Helmut Newton's Illustrated: No. 1–No. 4*. New York: Thunder's Mouth Press, 2000.

*Philippe Garner*

**NIGHTGOWN** Nightgown, now the term for women's or girls' garments worn to bed, is historically a somewhat confusing term. From the sixteenth through eighteenth centuries, it was a man's loose gown. In the seventeenth and eighteenth centuries, it was a woman's informal day dress—which was, as the name implies, originally an evening dress—hence women might quite modestly go to church in their nightgowns. While authorities believe that for much of Western history no specialized clothing—and sometimes no clothing—was worn for sleep, by the sixteenth century, nightclothes closely related to basic daywear had been adopted by both sexes.

For centuries, nightwear was cut like the male shirt and female smock or shift, with rectangular pieces for the body and sleeves and gussets under the arm, to avoid wasting fabric. It thus resembled what Lawrence Langner, in *The Importance of Wearing Clothes* of 1959 (p. 232), called "a bulky shapeless shirt hanging from the neck like a deflated balloon." As with underclothes, nightclothes absorbed perspiration, so needed to be washable; white linen, which could be boiled and bleached, was long the preferred fabric for all classes, with the quality of the linen denoting economic status.

In the nineteenth century, nightgowns became increasingly distinguishable from other feminine undergarments, featuring collars, yokes, and cuffs. *The Workwoman's Guide*, published in London in 1838, gives

directions (pp. 56–57) for economically cutting out and making several types of nightdresses, and notes that the high-collared style is neater in appearance, but that nightgowns with wide necklines waste less fabric and are particularly convenient for the ill, since they are easy to don and doff and allow “blisters, leeches, &c.” to be applied.

Ready-made nightwear became available in the mid-nineteenth century, but not until late in that century did nightgowns become more elaborate. Still cut loose and long, embellishment on the yoke, front placket, and cuffs could include all manner of ribbon, beading, lace, insertions, pin tucks, embroidery, and ruffles. Now usually of cotton, white remained the standard color, although the turn of the century saw occasional use of washing silk and colors, such as pink, which was said to wash well.

Pajamas entered the feminine wardrobe in the late nineteenth century, but long nightgowns remained popular, even after women’s skirts shortened in the early twentieth century. During the twentieth century, glamorous and luxurious lingerie grew ever more accessible and affordable. By the twenties, straight-cut silk and rayon nightgowns in delicate colors such as “flesh,” orchid, and green were popular, while the mid-century favored gowns with strappy bosom-hugging bodices above sinuous skirts. The advent of nylon allowed women to have—as the slogan for Chemstrand of the mid 1950s said—“all the luxury but none of the fuss,” (*Harper’s Bazaar* ad, 1956) with easy-care yet washable nightgowns and peignoirs that elegantly enhanced their femininity. Nightwear, however, became increasingly more colorful and diverse, responding to new fashion impulses. Young women’s “nighties” could be anything from men’s pajama tops to shortie “baby-doll” gowns, sometimes with matching panties.

In the late twentieth and early twenty-first centuries, nightgowns offered by companies such as Victoria’s Secret included romantic old-fashioned white cotton “nightdresses,” comfortable oversize knit sleep shirts, and sexy polyester satin baby dolls, reflecting the many roles and moods of modern women.

See also **Nylon; Pajamas.**

#### BIBLIOGRAPHY

- Cunnington, C. Willett and Phillis Cunnington. *The History of Underclothes*. London: Michael Joseph Ltd, 1951. New edition revised by A.D. Mansfield and Valerie Mansfield, published in London by Faber and Faber, 1981.
- Ewing, Elizabeth. *Dress and Undress: A History of Women’s Underwear*. London: B. T. Batsford, Ltd., 1978.

H. Kristina Haugland

**NONWOVEN TEXTILES** Nonwoven fabrics are made directly from fibers, bypassing both yarn-spinning and weaving, or knitting. Although technically fitting this

description, the age-old fabric, known as felt, is not considered to be a nonwoven fabric. Specific definitions of materials that can be termed nonwovens are given by the Association of the Nonwoven Fabrics Industry (INDA) in the United States and the European Disposables and Nonwovens Association (EDANA). Nonwovens must have a fabric density of less than 0.4 grams per cubic centimeter. Felt, made from wool fibers that are entangled by heat and moisture, is usually much heavier. Another property of a nonwoven textile is that over 50 percent of its weight must be fibers with a length-to-diameter ratio of at least 300. This eliminates paper, which is made of very short fibers. Nonwovens are often called fiber webs to distinguish them from these other materials.

Properties of nonwovens are particularly dependent on the fibers and processes used. General properties are a lack of drape and an inability to shear where yarns cross over, as in woven fabrics. This often makes them stiffer and less stretchable. They are also weaker than woven and knitted fabrics.

#### Production Processes

Nonwoven fabrics are often classified by the production processes used to make them. The two major steps in production are web formation and bonding. Each step has a number of variants, and the combination of web forming and bonding method determine a nonwoven’s properties and ultimate end-use.

There are several ways to form a fiber web. The traditional method is carding (also called dry laying), in which short, discrete, length (staple) fibers are pulled through wires to align them. This is the same process that is one of the steps in spinning yarns from staple fibers. Staple-fiber webs can also be made by air laying, where the fibers are suspended in air and collected on a moving belt; and by wet laying, a process similar to paper-making, where a mixture of fibers in water is collected on a screen, drained, and dried.

Webs can be formed from long continuous (filament) fibers as well. In these processes, spunbonding and



#### WHAT’S IN A DIAPER?

A disposable diaper comprises several different nonwoven fabrics. The inner liner is a spunbonded web, the outer layer is a dry-laid web bonded to a plastic film that prevents liquid from flowing through. The interior layer is a web of wood pulp and a super-absorbent fiber. There are also stretchable nonwovens in the tabs and other sections of the diaper.

meltblowing, melted polymers are extruded through many small holes and cooled and collected on a belt. The fibers in meltblown nonwovens are finer than those in spunbonded fabrics because high-velocity air is blown on the fibers as they are extruded, drawing them down to a smaller diameter.

Most webs formed by the methods described have little structural integrity, being a collection of fibers with mainly physical entanglement to hold them together. Subsequent bonding of the fibers is therefore necessary to provide that integrity. Bonding techniques used for dry- and wet-laid webs are adhesives, solutions, or heat, needle-punching, spunlacing, and stitching. Adhesives are glues that are sprayed or padded onto the webs. Alternatively, substances that dissolve the surfaces of the fibers can be applied, and when the dissolved surface areas dry, the fibers bond. A similar type of bonding can also be induced by heat if the web is composed of fibers that melt. The heat melts the fiber surfaces producing "thermal" bonds upon cooling that hold the fibers together. Spunbonded and meltblown nonwovens thermally bond when the fibers cool after being extruded. Passing the web through heated cylinders, called calendar rolls, bonds them more completely.

Needle-punched nonwovens have been subjected to a process in which a set of barbed needles moves in and out of the web, entangling the fibers. Spunlaced nonwovens have a distinctive, almost lace-like, appearance because they are produced by passing the web over a set of high-force water jets to entangle the fibers. Small holes are produced where the water penetrates the web and fibers become knotted and entangled around the holes. A final method that has been used to bond fiber webs is simple stitching through them with thread.

### Nonwoven Products

Many nonwoven textiles are destined for industrial uses, such as geotextiles for road reinforcement and ground and soil stabilization, roofing and insulation, dust cloths and wipes, home furnishings, and filters. They appear in garments and other wearing apparel as either durable or disposable products. One of the highest-volume disposable products is diapers, which have all but replaced cloth diapers in many countries. Nonwoven textiles are also used in other disposable items such as wipes, feminine-hygiene products, incontinence pads, surgical and medical examination gowns and masks. Surgical and other health-protection masks are often made with meltblown nonwovens that have good filtration properties due to the very fine fibers. An issue with all these disposable nonwoven products is lack of biodegradability and build-up in landfills. Some can be recycled; but, as can be imagined, recycling many of these items presents significant problems. In addition, since they are low-value, high-bulk, recycling is usually not economical.

While a great number of nonwoven textiles are disposable, there are end-uses in which a certain degree of

durability is desired. An early and continuing use of such nonwovens in clothing was as interfacings and interlinings. Interfacings are placed within garments to stiffen areas such as collars, cuffs, lapels, waistbands, and parts with buttons and buttonholes. Nonwovens, due to their resistance to shearing and stretching, help to stabilize these areas. In many cases the nonwoven interfacings have heat-activated adhesives on their surfaces so that they can be thermally bonded to the outer fabric. Non-adhesive nonwovens can be included in garments to provide insulation. New stretchable nonwoven textiles are being made for use in foundation underwear and some sportswear.

*See also* **Felt; Yarns.**

### BIBLIOGRAPHY

Oldrich, Jirsák, and Larry C. Wadsworth. *Nonwoven Textiles*. Durham, N.C.: Carolina Academic Press, 1999.

*Billie J. Collier*

**NORELL, NORMAN** The work of Norman Norell belongs within the exciting forefront of American fashion. From his first Traina-Norell collection in 1941 to the designer's death in 1972, Norell worked within a design vocabulary that presented his vision of the well-heeled American woman. While other American designers such as Claire McCardell presented an American sensibility primarily by redefining sportswear, Norell took a different approach in his career. He is credited with appropriating the quality and workmanship of French couture and applying these features to clothes produced on Seventh Avenue. Norell put an American twist on his highly sophisticated suits and dresses by adding polka dots, sailor collars, and schoolgirl bows. Fashion reports during Norell's career often claim that as an American designer Norell created certain styles, such as culottes and high-waisted dresses, ahead of his French contemporaries. Norell was a masterful fashion designer who used Seventh Avenue as the unlikely venue for his precisely made and wildly expensive clothes.

Norell was born Norman David Levinson, in Noblesville, Indiana, on 20 April 1900, the son of Harry and Nettie Levinson. As a child his attention to fashion derived from his mother's style of dress and her collection of fashion magazines; his father's haberdashery store in Indianapolis; and his early interest in clothes, interiors, and the theater. At the age of eighteen Norell went to New York City to attend the Parsons School of Design. Whether Norell actually attended Parsons or not for the year he claimed (Parsons cannot find any record of his enrollment), Norell's relationship with the school developed with his success, and Parsons claimed Norell as one of its illustrious graduates. Following a year spent back in Indianapolis opening a batik shop, Norell returned to New York to study at Pratt Institute in Brooklyn. At this



time Norell created a new name for himself by combining the first syllable of his first name with the sound of the initial letter of his surname.

From his studies of fashion illustration, drawing, and painting, Norell eventually discovered his *métier* in fashion and costume design. After finishing his studies at Pratt, Norell held a progression of jobs. In 1922 he worked for the film industry in Astoria, Queens, designing costumes for Rudolph Valentino in *The Sainted Devil* and for Gloria Swanson in *Zaza*. His career in theatrical costume design continued with stints designing for the Ziegfeld Follies and the Greenwich Village Follies, and at Brooks Costume Company, where he created costumes for burlesque, vaudeville, and nightclub revues. Norell's shift to women's clothing occurred in 1924, when he was hired by Charles Armour, a manufacturer of women's apparel. During the years that Norell worked for Hattie Carnegie (1928–1940), he had the invaluable opportunities of traveling to Europe, studying the construction of French couture dresses, and working with Carnegie's glamorous clients. Following a disagreement with Hattie Carnegie over a dress for Gertrude Lawrence in *Lady in the Dark*, a Broadway production, Norell left the firm and joined Anthony Traina, owner of A. Traina Gowns. Norell is often quoted as saying, "Mr. Traina called me and asked me to join him. He offered me a larger salary if my name were not used, a smaller amount if it was" (Morris, p. 46). Norell chose recognition over financial gain. Name recognition also served Norell in 1968 when he launched his perfume, "Norell."

From its inception in 1941 to Traina's retirement in 1960, Traina-Norell produced dresses, suits, and evening wear that combined an up-to-date sensibility with a feeling of timelessness. The label of Traina-Norell was formed with Anthony Traina as businessman and Norell as his employee, solely responsible for the designs of the collections. Of the first Traina-Norell collection, Bonwit Teller declared in *Vogue*, "The House of Traina-Norell comes on the season like an electrical storm. Its designer, young Mr. Norell, creates a collection so alive that everyone's talking" (*Vogue*, 1 October 1941, p. 5). Women purchasing a Traina-Norell garment were buying, at great cost, an American-made status symbol that would likely remain in their closets for decades. The high-class status of a Traina-Norell dress is invoked in the 1957 film *Sweet Smell of Success*, a reference known to audiences of that time but likely lost on most viewers today.

During the heyday of Traina-Norell, Norell established the basic designs that carried him through his career. The designer's body-fitting, sequined gowns, known as "mermaid dresses," were first shown in the 1940s. His chic shirtwaists, suits and chemise dresses, beautifully tailored coats, and clothes featuring polka dots, white schoolgirl collars, and oversize bows all became signatures of Norell's style. A *Harper's Bazaar* caption (March 1951) to a Norell ensemble captures it well:

"American Style—sharp and clean, a parlormaid's collar and cuffs of snowy organdie on a fitted jersey top, a snowy skirt, a streak of patent leather, and a red, red rose."

Following Traina's retirement in 1960, Norell opened his own firm, Norman Norell, New York. For its first collection Norell took his inspiration from the 1920s and his favorite designer, Chanel. Slinky, spangled evening dresses combined 1920s straight silhouettes with modern opulence. Also included in this premier collection was the wool culotte suit, considered revolutionary when it appeared. *Vogue* proclaimed (1 September 1960), "Now, for the first time in the history of modern fashion, a first-rank designer has based an entire suit-collection on the divided skirt" (p. 187).

Through the 1960s until his death in 1972, Norell continued to present elegant clothes of exemplary quality. His classics of sweater tops with evening skirts, chemise dresses, sequin-paved dresses and blouses, the sailor look in various guises, and ensembles mixing dressy satins with menswear flannel, had an ongoing prestige and allure that catered to his wealthy clientele.

Norell's talents were recognized in the early years of Traina-Norell. In 1943 he was the first designer to win the Coty American Fashion Critics' award; he won it again in 1951, and in 1956 was the first designer to earn a place in the Coty Hall of Fame. Norell was a founder and first president of the Council of Fashion Designers of America in 1965. His clothes have been featured in numerous exhibitions, most recently *Norman Norell* at the Fashion Institute of Technology (1998) and *Architects of American Fashion: Norman Norell and Pauline Trigère* at the Wadsworth Atheneum (2002). Norell suffered a stroke on 15 October 1972, only one day before his retrospective at the Metropolitan Museum of Art. He died days later on 25 October 1972. A statement made by Norell in the early 1960s encapsulates the designer's career, "To qualify as a designer one should not be afraid to repeat a good design, and certainly must have his own signature" (Kellen Archive Center, Parsons School of Design, Alumni Scrapbook 5). Norell followed these maxims to great success.

See also **Chemise Dress; Film and Fashion; Shirtwaist; Spangles.**

#### BIBLIOGRAPHY

- Baker, Therese Duzinkiewicz. "Norell, Norman." In *Contemporary Fashion*, edited by Taryn Benbow-Pfalzgraf. Detroit: St. James Press, 2002.
- "Break-Through in Fashion: The Culotte Suit for City Wear." *Vogue* (1 September 1960).
- Jacobs, Laura. "No One But Norell." *Vanity Fair* (October 1997): 356–367.
- Lambert, Eleanor. *World of Fashion: People, Places, Resources*. New York and London: R. R. Bowker Company, 1976.
- Lee, Sarah Tomerlin, ed. *American Fashion: The Life and Lines of Adrian, Mainbocher, McCardell, Norell, and Trigère*. New

- York: Quadrangle/New York Times Book Company, 1975.
- Levin, Phyllis Lee. *The Wheels of Fashion*. Garden City, N.Y.: Doubleday, 1965.
- Milbank, Caroline Rennolds. *Couture: The Great Designers*. London: Thames and Hudson, 1985.
- . *New York Fashion: The Evolution of American Style*. New York: Harry N. Abrams, Inc., 1989.
- Morris, Bernadine. "Norman Norell, Designer, Dies; Made 7th Ave. the Rival of Paris." *New York Times*, 26 October 1972.
- Roshco, Bernard. *The Rag Race: How New York and Paris Run the Breakneck Business of Dressing American Women*. New York: Funk and Wagnalls, 1963.
- Williams, Beryl. *Fashion Is Our Business*. Philadelphia and New York: J. B. Lippincott Company, 1945.

Donna Gbelerter

**NUDISM** Nudism is the practice of nonsexual social nudity, usually in mixed-sex groups, often at specially defined locations, such as nude beaches or nudist clubs. Nudism can be differentiated from the practice of spontaneous or private nude bathing ("skinny-dipping") in that it is an ongoing, self-conscious and systematic philosophy or lifestyle choice, rather than a spontaneous decision to disrobe. Nudists believe in the naturalness of the naked body, and in the medicinal, therapeutic, or relaxing properties of unself-conscious social nudity. They believe that modesty and shame are socially imposed restrictions on the freedom of the naked body, and that eroticism is not a necessary condition of nakedness. They frequently emphasize the importance of *total* nudity, arguing that partial concealment is more sexual than total exposure.

### Early Nudism

Nudism arose in Germany at the turn of the twentieth century, and spread through Europe, the United States, and Australia. The so-called "father of nudism" was the German Heinrich Pudor (real name Heinrich Scham), who coined the term *Nacktkultur* ("naked culture") and whose book *Nackende Menschen* (Naked man [1894]) was probably the first book on nudism. Richard Ungewitter (author of *Die Nacktheit* [1906]) is more widely known as the founder of nudism, his reputation having survived Pudor's accusations of plagiarism.

Nudism flourished in Germany, France, England, elsewhere in Europe, and in the United States, but its advocates often had to fend off legal challenges or accusations of depravity. While nudism had distinctive national flavors, and there was occasionally some rivalry (especially between the French and the Germans), there was also considerable communication, influence, and overlap between nudist cultures. Nudism was known by many names: in Germany, as *Nacktkultur*, *Freikörperkultur* (free-body culture), or *Lichtkultur* (light culture); in

France as *nudisme*, *naturisme*, or *libre-culture* (free culture), and in England as Gymnosophy or naturism.

Germanic nudism was a proletarian movement, mostly communitarian and ascetic in style. Its constituency was largely the unemployed and the working poor. By and large however, nudism was a movement endorsed and organized by educated people—physicians, scientists, lawyers, clergy, and, in France especially, occasionally by members of the aristocracy. Nudism produced an extensive proselytizing literature. Key nudist figures or writers of the 1920s and 1930s included: in Germany, Adolf Koch, Paul Zimmerman, and Hans Surén; in France, Marcel Kienné de Mongeot, the Durville brothers, and Pierre Vachet; in the United States, Maurice Parmelee and Frances and Mason Merrill; and in England, the Reverend Clarence Norwood, John Langdon-Davies, and William Welby. Nudists often met with religious opposition, but there were also many openly Christian nudists, who argued that it was time for Christianity to rid itself of superstition.

Early nudism was a medical, philosophical, and political movement. Its key contentions were the therapeutic benefit of unhindered access to sun and air, and the psychological benefit of an open relation to the naked body. Nudist writing commonly begins with cross-cultural and historical examples demonstrating the relativity of shame and modesty, before proceeding to expound the psychological, moral, social, and physical benefits of nudity. Clothing was considered to be both an instrument of class oppression and a major cause of ill health. Nudists claimed that an excess of shame and modesty bred psychological complexes, unhealthy relations between the sexes, and produced bodies that were both unhealthy and an affront to beauty.

The contribution of nudism to the aesthetics of the race was regularly cited as one of its benefits. Maurice Parmelee, for example, argued that nudism would contribute to a more "beautiful mankind" (p. 179). Some nudist clubs banned the disabled and the corpulent as a punishment for unhygienic lifestyles, but other nudists were troubled by too strong an emphasis on the aesthetic:

While extreme cases of deformity and mutilation can be so distressing and painful to view that there may be some justification for such exclusion, it is of supreme importance that the gymnosophy movement be maintained on a lofty humanitarian plane (*Parmelee*, pp. 179–180)

The relation between nudism and eugenics was complex, and use of an aesthetic discourse is no simple marker of eugenic thought or of fascism. Although Pudor, for example, was overtly anti-Semitic, Karl Toepfer warns that there was no "deep, inherent connection" between Germanic body culture and Nazism (p. 9).

Nudism was neither simply reactionary nor progressive. On the one hand, it was a trenchant critique of modernity. Nudist physicians lamented the soot-choked

air of industrial cities and the lack of exposure to fresh air and sunlight of most working people. Socialist accounts argued that this physical malaise was compounded by the role of clothing in effecting oppressive social stratification; clothes were seen as masking the innate equality of all people. Some nudist writing is characterized by a romantic and nostalgic evocation of nature, a conception no doubt aided by the use in England and France of the euphemistic alternative “naturism” (a term that, incidentally, appears to be gaining some favor in contemporary nudism as a more “acceptable” term than nudism). For many writers, however, nudism was emphatically *not* a return to nature. As Parmelee put it, the idea that nudists want to discard anything artificial or man-made was “manifest folly” (p. 15). Scientists and physicians saw nudism not as a return to Eden (although this trope certainly occurred in nudist writing), but as a path forward to a shining new modernity in which science, rather than superstition, would lead the way.

Nudism was thus not (only) nostalgic but also saw itself as *modern* and *rational*. Nudist writing intersected with a raft of other modern discourses—heliotherapy (sun-cure), sexology, socialism, feminism, and eugenics. Caleb Saleeby, for example, was a fervent advocate of nudism, heliotherapy, and eugenics (he was Chairman of the National Birthrate Commission and author of a number of books on eugenics). Sexologist Havelock Ellis considered nudism to be an extension of the dress reform movement for women, and Maurice Parmelee saw it as a powerful adjunct to feminism. Ennemond Boniface was a socialist nudist, who fervently believed that nudism was an alternative to bloody socialist revolution, and would bring about a new naturist era in which all would be equal under the sun (see sidebar). For many, nudism was not just a therapeutic practice; it was a revolutionary plan for an egalitarian utopia.

### Contemporary Nudism

There are a number of forms of contemporary organized nudism, each with a somewhat distinct culture: nude beaches, nudist resorts, nudist clubs, and swim-nights. “Clothes optional” resorts are becoming more common in some countries, as part of the growth of naturist tourism.

The utopian and political underpinning of early nudism has largely disappeared. Nudism has remained a minor practice, and it has by and large mutated into a “lifestyle” chosen by individuals rather than either a medical practice or a program for social reform. Contemporary nudists tend to be more private and less evangelical about their practice, and they are unlikely to see it as connected to any form of radical philosophy or politics. The major benefits are, they believe, a relaxed lifestyle and a healthy body image.

Body image is, in fact, the one social issue around which nudists are likely to be united in their opinion. Whereas for the early nudists, one of the prime benefits of nudism was that it would promote healthy, beautiful



### NUDISM AND CAPITALISM

The French socialist Ennemond Boniface predicted that nudism would bring about the end of capitalism:

“[T]here will be an exodus . . . from the cities, and the willing return . . . to the good nourishing earth. Little by little, men will desert the monstrous, nauseating agglomerations [of our] towns, in order to found . . . new and increasingly numerous naturist towns. Then . . . the factories, those places of hard labor where decent folk are imprisoned, will progressively become empty. The ferocious reign of the industrialist and his accomplice the banker will be over” (Salardenne, p. 93).

bodies and, by social selection, contribute to the elimination of unhygienic or unappealing bodies, contemporary nudists see nudism as a way of escaping the debilitating effects of the modern obsession with the body beautiful. They believe that nudism teaches one to be comfortable with one’s body, whatever it looks like.

See also **Nudity**.

### BIBLIOGRAPHY

- Barcan, Ruth. *Nudity: A Cultural Anatomy*. Oxford: Berg 2004.
- . “‘The Moral Bath of Bodily Unconsciousness’: Female Nudism, Bodily Exposure and the Gaze.” *Continuum: Journal of Media and Cultural Studies* 15.3 (2001): 305–319. On contemporary female nudists’ accounts of the benefits of nudism.
- Clapham, Adam, and Robin Constable. *As Nature Intended: A Pictorial History of the Nudists*. Los Angeles: Elysium Growth Press, 1982. Useful history.
- Clarke, Magnus. *Nudism in Australia: A First Study*. Victoria: Deakin University Press, 1982. A comprehensive study.
- Merrill, Frances, and Mason, Merrill. *Nudism Comes to America*. New York: Alfred A. Knopf, 1932.
- Norwood, C. E. (Rev). *Nudism in England*. London: Noel Douglas, 1933.
- Parmelee, Maurice. *Nudism in Modern Life: The New Gymnosophy*. London: Noel Douglas, 1929. An account of the benefits of nudism by a nudist physician, with an introduction by Havelock Ellis.
- Pudor, Heinrich [Heinrich Scham]. *Naked People: A Triumph-Shout of the Future*. Translation by Kenneth Romanes. Peterborough: Reason Books, 1998 [1894]. Earliest nudist text; little read.
- Salardenne, Roger. *Le nu intégrale chez les nudistes français: Reportage dans les principaux centres*. Paris: Prima, 1931.
- Saleeby, C. W. *Sunlight and Health*. London: Nisbit and Company, 1923. A eugenic view.



Toepfer, Karl. *Empire of Ecstasy: Nudity and Movement in German Body Culture, 1910–1935*. Berkeley: University of California Press, 1997.

Ruth Barcan

**NUDITY** Nudity is paradoxical—a bodily state that is seen as so banal or matter of fact that it is rarely given sustained conceptual or academic treatment, while all the while most societies subject it to intense regulation via customs, taboos, and laws. Nudity is customarily imagined as a “natural” state—since we are all born naked—and yet its powerful social and cultural regulation means that it is anything but simple or natural.

Nudity might seem so uncomplicated as to need no definition; it is simply the state of being without clothes. But this is too simple. In the past, the word *naked* could mean clad only in an undergarment. In fine art, the term “nude” almost always includes semiclad or lightly draped bodies. So too, in some legal jurisdictions, the erect penis is legally “nude” even when covered in an opaque fabric. Conversely, some uncovered parts of the body—an elbow, a nose, a wrist, a face—are unlikely to be considered naked. Definitions of nudity, which are subject to historical and cultural variation, rely on assumptions about what counts as clothing. Defining nudity can also be an ideological or political matter. Are ornamentation, tattooing, feathers, skins, jewelry, or even hairstyles forms of clothing? This can matter greatly, as in the colonial context, where nudity was often seen as a sign of savagery.

#### Nakedness versus Clothing

Nakedness and clothing help define each other. They can function as “nuclei” of humans’ “sense of order” (Clark, p. 4), as in the following sample list of fundamental sense-making oppositions in the Western tradition:

- nakedness vs. clothing
- natural vs. cultural
- unchanging vs. changeable
- invisible vs. visible
- truth vs. lies
- pure vs. corrupt
- human nature vs. human society
- pre-, non-, anti-social vs. social

These terms are valued according to context, blurry at their edges, and occasionally reversible. Thus, nakedness has been able to be imagined as both an indecent state needing to be covered by “culture” (clothing) and a pure state far superior to the indecent cultural masquerade of clothing. The nakedness of “savages,” for example, has been imagined as evidence of their inferior humanness—but it has also been subject to romanticization (the “naturalness” of the “noble savage”).

#### Metaphorical Meanings of Nudity

In the Western tradition, nudity can, broadly speaking, attract both positive and negative metaphorical meanings.



“It is widely supposed that the naked human body is in itself an object upon which the eye dwells with pleasure and which we are glad to see depicted. But anyone who has frequented art schools and seen the shapeless, pitiful model which the students are industriously drawing will know that this is an illusion” (Clark, p. 3).

Mario Perniola has argued that these opposing meanings arise from the different metaphysics underlying the Greek and the Judaic traditions. In the Platonic tradition, he argues, truth was understood as something to be unveiled. Nudity, therefore, accrued metaphorical meanings of truth, authenticity, and innocence. Moreover, in sculptural and athletic practice, the ideal human figure was naked. In the Judaic tradition, however, in which the Godhead was imagined as gloriously *veiled*, nakedness was more likely to signify degradation, humiliation, or loss of personhood. It is important to stress that this is a simplification; there was internal complexity within, and interchange between, the two systems of meaning. In any case, metaphorical meanings and lived practice did not always match up; nor were the idealized meanings of nudity open to all types of naked bodies (for example, those of women, older men, or slaves).

#### The Naked and the Nude

English has two major terms for the state of undress: nakedness and nudity. Nakedness is the older word, coming from the Germanic family of languages. Nude is of Latin origin, entering the language in late Middle English. The original connotations of these terms persist—nakedness tends to suggest a raw, natural state, while nudity suggests a state of undress refined by culture into an aesthetic state.

Within fine arts, this etymological nuance has been elaborated into a full-fledged aesthetic distinction between the naked and the nude, a distinction most famously articulated by Kenneth Clark. Put simply, Clark’s opposition is this: nakedness is the “raw” human body, the human body without clothes. Nudity results when the artist works on that raw material. Thus, the nude is not a subject of art but a form of art (p. 3). John Berger glosses it thus: nakedness is a starting point and the nude is “a way of seeing” (p. 53). Nakedness is imperfect and individual; the nude is ideal and universal. Nakedness is nature; nudity, culture. The artist’s work de-particularizes the model’s nakedness, lifting it into ideality.

Conceptually, the difference relies on the myth of an unmediated original bodily state—as though there were in the first place some raw “nature” untouched by cul-



"[I]n our Diogenes search for physical beauty, our instinctive desire is not to imitate but to perfect. This is part of our Greek inheritance ... 'Art,' [Aristotle] says, 'completes what nature cannot bring to a finish'" (Clark, p. 9).

ture. The opposition also depends on underlying value judgments that have made it politically unpalatable to some. Some feminists, for example, have seen much to criticize in Clark's denigration of the naked as a pitiful state. We are, says Clark, "disturbed" by the natural imperfection of the naked body, and we admire the classical scheme that eliminates flaws, wrinkles, and signs of organic process: "A mass of naked figures does not move us to empathy, but to disillusion and dismay. We do not wish to imitate; we wish to perfect" (p. 4). For many feminists, such unabashed idealism is not only conceptually untenable, it is politically suspect, since it denigrates the (traditionally feminized) body.

Clearly, the idealizing processes Clark describes are not limited to classical art. They are the backbone of the glamorizing tendencies of contemporary consumer culture, as critics such as John Berger first pointed out. Contemporary advertising favors smoothed, youthful surfaces, and it employs its own techniques, including image manipulation, to ensure that bodily ideals do not "disturb" us with signs of imperfection. It is not hard to see why feminists have by and large been less than enthusiastic about the distinction between the naked and the nude, since they are critical of the pressures that such idealization puts on women, especially, and argue that dissatisfaction with the "natural" body is a major cause of psychological and cultural malaise.

See also **Nudism**.

**BIBLIOGRAPHY**

Barcan, Ruth. *Nudity: A Cultural Anatomy*. Oxford: Berg, 2004.  
 ———. "Female Exposure and the Protesting Woman." *Cultural Studies Review* 8 no. 2 (2002): 62–82.  
 Berger, John. *Ways of Seeing*. London: BBC; Harmondsworth: Penguin, 1972. Explores the naked/nude distinction in art and advertising.  
 Clark, Kenneth. *The Nude: A Study of Ideal Art*. Harmondsworth: Penguin, 1956. Classic discussion; source of naked/nude distinction.  
 Hollander, Anne. *Seeing through Clothes*. Berkeley: University of California Press, 1993.  
 Miles, Margaret R. *Carnal Knowing: Female Nakedness and Religious Meaning in the Christian West*. Boston: Beacon Press, 1989.

Nead, Lynda. *The Female Nude: Art, Obscenity, and Sexuality*. London: Routledge, 1992. Feminist text that includes an extended critique of the naked/nude distinction.

Perniola, Mario. "Between Clothing and Nudity." Translated by Roger Friedman. In *Fragments for a History of the Human Body. Part Two*, pp. 236–265. Edited by Michel Feher, with Ramona Naddaff and Nadia Tazi. New York: Zone, 1989. Outline of nakedness in Greek and Judaic traditions.

Ruth Barcan

**NYLON** Nylon was the first fiber to be synthesized from petrochemicals and became known as the "miracle fiber." Its inventor was American chemist Wallace Carothers of the DuPont Company. Introduced in 1931, it was first called "66." By 1938 Paul Schlack, a German chemist from the I.G. Farben Company, created a different form of the fiber known as nylon 6. In 1941, British Nylon, Inc. began nylon 6 production in Great Britain. Invented two decades after rayon and acetate, nylon opened the door for synthetic fiber inventions that revolutionized the global textile industry.

DuPont began commercial production of nylon in 1939 by featuring women's hosiery at the San Francisco Exposition. It was one of the most exciting fashion innovations of the age, and women were intrigued by the strength, beauty, and low cost of nylon stockings compared to silk stockings. World War II diverted production of nylon to the war effort as it was used in products like parachutes, ponchos, tires, ropes, tents, and even U.S. currency. When commercial production resumed after World War II thousands of women lined up in New York City to purchase nylon hosiery.

Neil Armstrong planted a nylon flag on the moon in 1969 while wearing a nylon and aramid space suit, symbolizing the futuristic aura of the "miracle fiber." Synthetic fibers can be produced in various modifications. Throughout its history special-purpose nylon fibers have been developed. The Japanese company, Kuraray, began developing leather-look microfiber nylon in 1964, which is used for high-fashion apparel, sportswear, and luggage. A lustrous and luxurious-appearing Qiana nylon was introduced in the early 1970s as an innovation with the triangular cross-sectional shape of silk. It is no longer made. Antron nylon had similar properties and continues to be produced.

Consumers found nylon to be less comfortable than natural fibers. One solution was to blend nylon with other fibers to enhance strength and improve comfort. Modifications produced Hydrofil nylon, which was engineered for increased absorbency. Recent development of microfiber nylon (fibers with exceptionally fine diameters) added a comfort dimension first appreciated in active sportswear, such as athletic wear made of Tactel microfiber nylon produced by DuPont. Designer and consumer-level fashion acceptance of microfiber prod-

ucts continues to grow and with it may come a resurgence of nylon in apparel fashion.

Research into possible innovations for nylon continues. One frontier is micro-encapsulation in medical applications, in which nutrients and supplements encapsulated in the apparel are released as therapy to the body. Encapsulation appeared in interior textiles as perfume in furnishings used to set the mood of a room. Nylon is produced in Asia, North America, Western Europe, and Eastern Europe, with production growth showing a marked shift to Asia. Nylon's share of fiber production has decreased from 20 percent in 1982 to 11 percent in 2002. Polyester at 58 percent has clearly become the dominant synthetic fiber.

### Production of nylon

Nylon is chemically synthesized from petrochemicals by reacting an acid with an amine. The variant of amine and acid determines the resultant type of nylon (e.g. 66 or 6). The compounds form a nylon salt that is dried and heated under a vacuum to eliminate water and form a polymer known as polyamide. In the technical textile literature nylon may be referred to as polyamide. The polyamide is melted, passed through a spinneret with holes, and drawn in long continuous filaments. Variations in the steps of this process allow producers to engineer specific properties. Often yarns are texturized (treated to change the surface texture) in order to add character, stretch, or bulk. Fibers are then processed into yarns relative to use.

### Characteristics of nylon textiles

Nylon is known for its high strength, abrasion resistance, durability, elongation, and versatility. These properties make nylon highly suitable for heavy poplin and taffeta upholstery and luggage fabrics. The versatility of nylon allowed for creation of the aesthetics of natural fibers with far better performance. Because of excellent elongation, nylon has been particularly well suited for knitwear. Comfort has been a challenge, though, given low absorption and a medium heat retention that contribute to sweating when physically active. Hydrophil has been engineered to provide absorption and wicking (moisture transport). Nylon taffeta has been used extensively for rainwear, umbrellas, and wind-resistant garments. Static is another outcome of low moisture absorption that can be uncomfortable and possibly unsafe in some environments. Antistatic variants have been developed to manage this problem in garments and in carpeting in which finishes or small amounts of metallic and carbon fibers are used. Nylon can be heat set, making it highly resilient and shrink resistant at normal temperatures; however, at very high heat it can wrinkle, shrink, and even melt. Nylon resists damage from chemicals and is also resistant to mold, mildew, and insects. It is less resistant to damage

from sunlight. Nylon attracts oil-based stains and performs best if treated with stain-release finishes. This is particularly needed for carpeting and upholstery.

### Nylon in fashion across time

Introducing nylon through women's nylon hosiery created a fashion frenzy never seen for any other manufactured fiber. The momentum of this introduction made nylon the leading synthetic fiber until 1969 when polyester consumption overtook nylon. One major feature of these new textiles that had great appeal was "wash and wear," in which ironing became a seldom-or-never kind of expectation for relatively wrinkle-free textiles. Growth in popularity of knitwear, particularly sportswear, contributed to the fashionability of synthetic apparel. Yet, attempts to make nylon appealing in apparel have met with numerous comfort issues for typical clothing, leading to a perception that nylon is uncomfortable when worn. With ongoing innovations in sportswear and high fashion, nylon continues to be a fiber with a bit of "miracle" pending.

### Common nylon textile uses

The primary demand for nylon is for carpeting; 80 percent of carpeting is nylon. Other interior-textile uses include bedspreads, window treatments, and upholstery. Within apparel, nylon is used in hosiery, particularly women's sheer hosiery, lingerie, foundation garments, raincoats, linings, windbreakers, and a wide array of athletic wear in which the stretch of nylon is an asset. Industrial uses are extensive and include tire cord, car headliners and trunk liners, car trims, clutch and brake pads, radiator and other hoses, car airbags, conveyer and seat belts, parachutes, racket strings, ropes and nets, sleeping bags, tarpaulins, tents, thread, fishing line, brushes, sports gear, luggage, and dental floss.

See also **Acrylic and Modacrylic Fibers; Rayon.**

### BIBLIOGRAPHY

- Braddock, Sarah, and Marie O'Mahony. *Techno Textiles: Revolutionary Fabrics for Fashion and Design*. New York: Thames and Hudson, Inc., 1998.
- Collier, Billie, and Phyllis Tortora. *Understanding Textiles*. New York: Macmillan Publishing, 2000.
- Hatch, Kathryn. *Textile Science*. Minneapolis: West Publishing, 1993.
- Kadolph, Sara, and Anna Langford. *Textiles*. 9th ed. New York: Prentice-Hall, 2002.

### Internet Resource

- "Fibersource." American Fiber Manufacturers Association/Fiber Economics Bureau. Available from <<http://www.fibersource.com>>.

Carol J. Salusso





**Top: Fan painted with *The Toilette of Cupid*.** During the seventeenth century, European fans saw a great increase in quality of design and technique. (See Fans) © V&A Picture Library, Photographer: Sara Hodges.

**Middle: Reverse of fan depicting *The Toilette of Cupid*.** Fans of the seventeenth century often featured scenes from works of art created during the baroque period, and both sides of the fan were generally painted. (See Fans) © V&A Picture Library

**Bottom: Mid-eighteenth-century French fan.** France was the primary producer of fans in the eighteenth century. The rococo style had a profound effect on fans during this time, and the decorations became lighter and more graceful. (See Fans) © V&A Picture Library, Photographer: Sara Hodges.





---

**Top: Felt saddle covering, Russia, 400 B.C.E.** Made mostly from wool, felt is a good insulator and a remarkably strong and versatile material that can be stretched and molded for various uses. (See Felt) © The State Hermitage Museum, St. Petersburg. Reproduced by permission.

**Bottom: Machine for producing synthetic fiber.** Synthetic fibers, including nylon and polyester, are created from chemicals substances. Synthetic fibers and regenerated fibers are known as manufactured, or man-made, fibers. (See Fibers) © John Madere/Corbis.

---

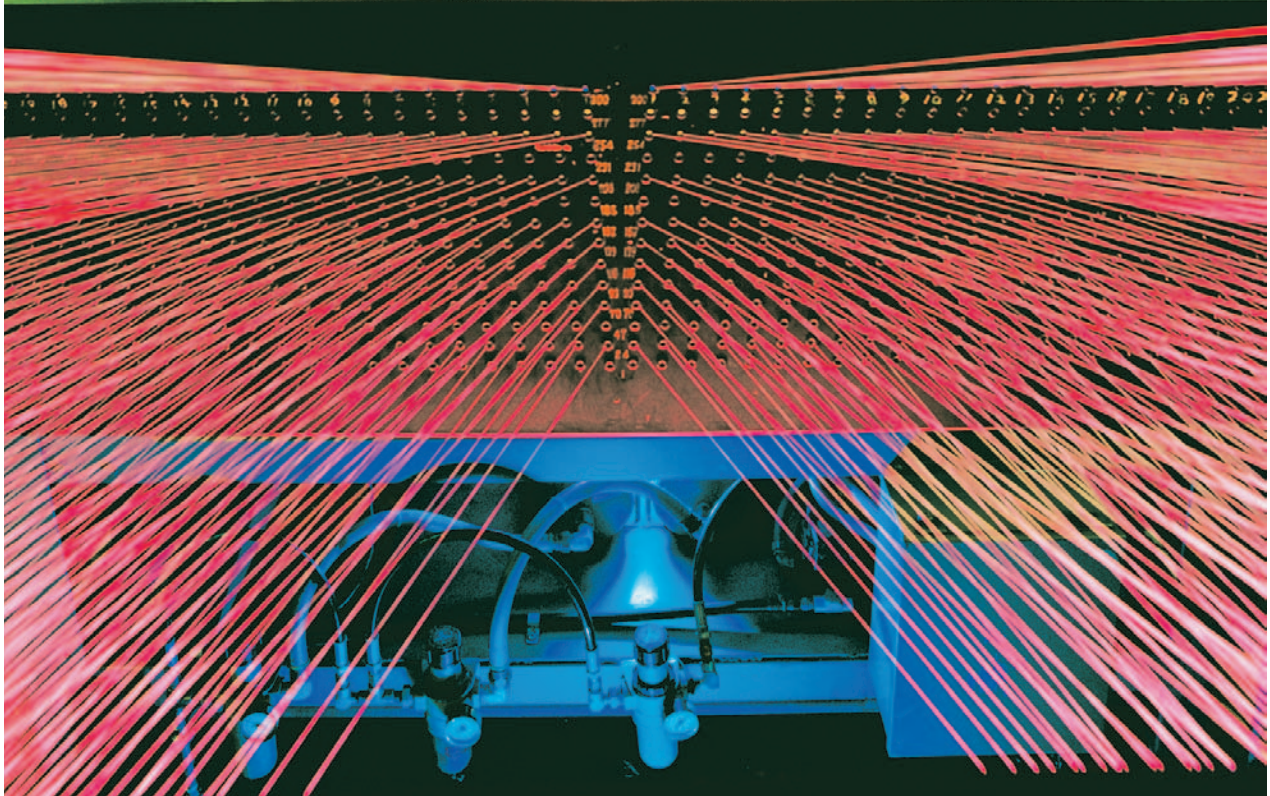
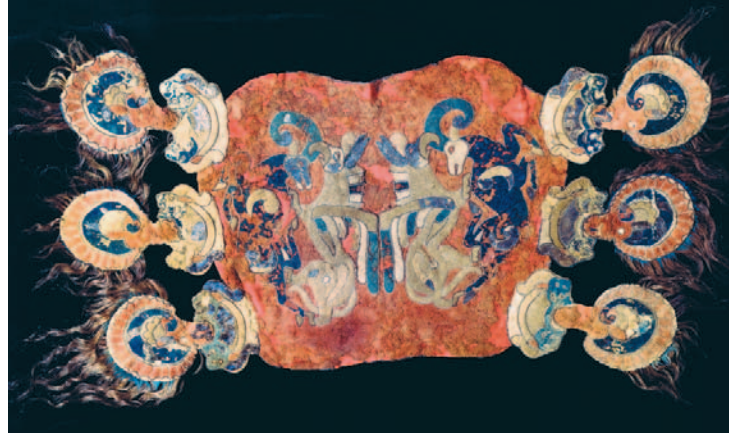





---

**Below: Thierry Mugler 1997–1998 fall/winter haute couture collection.** The Paris haute couture system, which garners international attention and prestige, generates profitable deals on ready-to-wear clothing, perfume, and more. (See Haute Couture) AP/Wide World Photos.

**Inset: Roberto Capucci with one of his designs, 1993.** Capucci began his career early, opening his first *atelier* when he was not yet twenty years old. His designs often exhibited unusual structure and volume. (See Haute Couture; Capucci, Roberto) © Vittoriano Rastelli/Corbis.

---







**Top, right: African women wearing headdresses.** Headdresses are worn for both decorative and practical purposes. Depending on design, they can indicate religion, social rank, political affiliation, or a combination of all three. (See Headdress) Hulton/Archive by Getty Images.

**Below: Performers at Aztec dance.** Feathers from birds such as the quetzal and the eagle have long been used in the tribal headdresses of the Aztecs. (See Headdress) © Wolfgang Kaehler/Corbis.





---

**Top, left: Central Asian ikat coat.** All three varieties of *ikat* dyeing techniques were prevalent in India, and the garments featured an extensive array of designs and colors. (See *Ikat*) Ashmolean Museum, Oxford. Reproduced by permission.



**Middle, left: Sari designer Paul Satya with customers.** The *sari*, a wrapped garment, is among the most prevalent form of dress in India. Wrapping methods and decorative embellishments can vary widely from region to region. (See *India: Clothing and Adornment*) © John Van Hasselt/Corbis Sygma.

**Below: Indian designer Seerat Narindra.** Narindra worked together with Indian women whose lives had been devastated by a 1996 earthquake to bring their traditional handiwork to her contemporary fashion designs. (See *India: Clothing and Adornment*) © Lindsay Hebbert/Corbis.

---







**Top, left: Portrait of a Gentleman, by Bartolomeo Veneto.** In the sixteenth century, round brooches called *enseigne* were pinned by Italian men on the upturned brim of their hats. (See Jewelry; Brooches and Pins) © Massimo Listri/Corbis.

**Below: Indian woman wearing elaborate jewelry.** By the beginning of the twenty-first century, decorative jewelry was worn almost exclusively by Indian women, although men from royal families sometimes wore jewels for special occasions. (See Jewelry; India: Clothing and Adornment) © Robert Holmes/Corbis.







---

**Top, left: South Korean model in Swatch ensemble.** By the late twentieth century, the materials that could be used to create jewelry knew little boundary, and items such as watches were not restricted to the traditional placement on the wrist. (See Jewelry; Korean Dress and Adornment) Getty Images.

**Below: Korean baby in traditional clothing.** Korean children's clothing is similar to that of adults, except that the colors may be brighter and warmer. For special occasions, children may wear a rainbow-striped *chogori*. (See Korean Dress and Adornment) © Nancy Brown/Corbis.

---





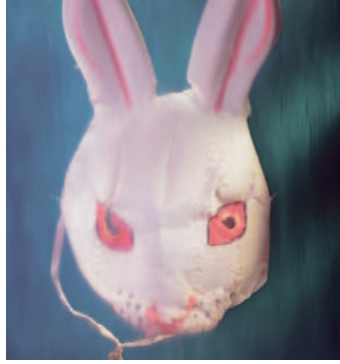

**Above: Evil-bunny Halloween mask.** Despite being sanctioned by neither church nor state, Halloween is a major holiday in the United States. It has its origins in the ancient Celtic tradition of Samhain, a day in which it was believed that the souls of the dead were especially restless. (See Masks; Halloween Costume) Photo by Phyllis Galemba.

**Right: Indian "Elephant March" mask.** A man wears an intricate mask during the Great Elephant March, a celebration that takes place each January in India. (See Masks) © Hans Georg Roth/Corbis.

**Below: Masked revelers.** The emphasis of carnivals is on spectacle, and the more eye-catching the costume, the better. Many festivals even feature competitions, with judges awarding prizes for the most inventive costumes, many of which include masks. (See Masks; Carnival Dress) AP/Wide World Photos.



SCRIBNER LIBRARY OF DAILY LIFE

---



# ENCYCLOPEDIA OF CLOTHING AND FASHION

*Valerie Steele, Editor in Chief*

---

VOLUME **3**



SCRIBNER LIBRARY OF DAILY LIFE



**ENCYCLOPEDIA OF  
CLOTHING  
AND FASHION**





## EDITORIAL BOARD

---

***Christopher Breward***

London College of Fashion

***Joanne B. Eicher***

University of Minnesota

***John S. Major***

China Institute

***Phyllis Tortora***

Author of *Understanding Textiles*, *The Fairchild Encyclopedia of Fashion Accessories*, and *The Fairchild's Dictionary of Textiles*

SCRIBNER LIBRARY OF DAILY LIFE



ENCYCLOPEDIA OF  
CLOTHING  
AND FASHION



VOLUME 3:  
Occult Dress to Zoran, Index

*Valerie Steele, Editor in Chief*

**CHARLES SCRIBNER'S SONS**

*An imprint of Thomson Gale, a part of The Thomson Corporation*

**THOMSON**  
—★—™  
**GALE**





## Encyclopedia of Clothing and Fashion

Valerie Steele, Editor in Chief

© 2005 Thomson Gale, a part of the Thomson Corporation.

Thomson and Star Logo are trademarks and Gale and Charles Scribner's Sons are registered trademarks used herein under license.

*For more information, contact*

Thomson Gale  
27500 Drake Rd.  
Farmington Hills, MI 48331-3535

Or you can visit our Internet site at  
<http://www.gale.com>

**ALL RIGHTS RESERVED**

No part of this work covered by the copyright hereon may be reproduced or used in any form or by any means—graphic, electronic, or mechanical, including photocopy-

ing, recording, taping, Web distribution, or information storage retrieval systems—without the written permission of the publisher.

For permission to use material from this product, submit your request via Web at <http://www.gale-edit.com/permissions>, or you may download our Permissions Request form and submit your request by fax or mail to:

*Permissions Department*  
Thomson Gale  
27500 Drake Road  
Farmington Hills, MI 48331-3535  
Permissions Hotline:  
248-699-8006 or 800-877-4253 ext. 8006  
Fax: 248-699-8074 or 800-762-4058

While every effort has been made to ensure the reliability of the information presented in this publication, Thomson Gale does not guarantee the accuracy of the data contained herein. Thomson Gale accepts no payment for listing; and inclusion in the publication of any organization, agency, institution, publication, service, or individual does not imply endorsement of the editors or publisher. Errors brought to the attention of the publisher and verified to the satisfaction of the publisher will be corrected in future editions.

### Library of Congress Cataloging-in-Publication Data

Encyclopedia of clothing and fashion / Valerie Steele, editor in chief.  
p. cm. — (Scribner library of daily life)

Includes bibliographical references and index.

ISBN 0-684-31394-4 (set: hardcover: alk. paper) — ISBN 0-684-31395-2 (v. 1) —  
ISBN 0-684-31396-0 (v. 2) — ISBN 0-684-31397-9 (v. 3) — ISBN 0-684-31451-7 (e-book)

1. Clothing and dress—History—Encyclopedias. I. Steele, Valerie II. Series.

GT507.E53 2005

391'.003—dc22

2004010098

This title is also available as an e-book.

ISBN 0-684-31451-7

Contact your Thomson Gale Sales representative for ordering information.

Printed in the United States of America

10 9 8 7 6 5 4 3 2 1



**OCCULT DRESS** Occultism is any nonmainstream Western system of spirituality that uses magic, the definition of magic being the way in which internal thoughts are used to effect changes in the outside world. Occultists, such as northern European Pagans (e.g., Wiccans, Druids, and witches) and ceremonial magicians (Cabalists, hermetics, and the like) practice magic as part of their religions. Occult dress is used when participating in magic rites, rituals, or ceremonies. Western occult dress has three primary functions: (1) to psychologically place the wearer in an extraordinary sense of reality; (2) to identify the status of the wearer within a social group; and (3) to indicate the beliefs of the wearer.

### **Clothing**

Occult beliefs promote nudity as occult dress, because clothing is believed to impede the flow of magical energies through the body from the surrounding environment. Wicca practitioners and witches have traditionally performed rites in the nude to show their devotion to the Wiccan goddess. Due to modesty or weather, some occultists wear robes or tunics with bare feet and no undergarments. This latter dress is believed to still allow the flow of magical energies. Many covens and magical groups have set occult dress guidelines, using tradition or personal tastes as a basis for these guidelines. Occult dress, especially nudity, is not a common Western mode of dress, therefore it psychologically alerts and reinforces the awareness of special occasions and presence of magic for occultists. Each magical group sets the guidelines for occult dress. There is not a specific literature, although a magical group may draw inspiration from books, movies, or even more mainstream cultural practices.

Some occult groups don garments symbolically colored according to a ceremony or rite. For example, a Northern European Pagan coven may don white clothes to celebrate Yule rites and green clothes to celebrate Beltane festivals. Ceremonial magic groups, such as the Hermetic Order of the Golden Dawn, have an extensive magical color symbolism, and thus certain colored clothing is worn for a specific ritual. This is done in order to mentally link the practitioner to the rites being performed, raising awareness and effectiveness of the spiritual ritual.

Occult dress is also used to indicate status within a group. Wiccan high priestesses of Alexandrian lineages indicate status to other initiates by a colored leg garter. Also, a waist cord may be worn in the same group to indicate the wearer having taken oaths pertaining to a level of initiation. Other occult groups, such as the Order of Bards, Ovates, and Druids, who originated in England, wear colored robes denoting rank during some occult ceremonies.

Cultural disposition is another motivation for specific occult dress. For example, Asatru practitioners may don tunics and mantles of historic Germanic styles to denote their affiliation to the ancient Teutonic religion. Celtic knotwork designs on clothing and jewelry may be worn to show an affiliation to Druidism and other ancient Celtic spiritualities.

Western occult dress tends to be self-manufactured (sewn by the practitioner or by a fellow occult member), or if technical skills are lacking, utilizes existing everyday clothing for a magical purpose such as a silk bathrobe purchased at a department store that could be worn in ritual as magical raiment.

### **Jewelry**

Jewelry is used to indicate occult status or beliefs. A Wiccan priestess may don a silver tiara or crown emblazoned with moon-phase symbols, while a Wiccan practitioner or a Witch may wear a necklace with a moon or feminine symbol. Both silver metal and the moon symbolize the Goddess and feminine energies. A Wiccan priest may wear a headdress of antlers to symbolize fertility, fecundity, and the God of Wicca. A high priest or other practitioner may wear a necklace or torc decorated with appropriate spiritual symbols.

The pentacle, a disk emblazoned with a five-pointed star known as a pentagram, is commonly worn by many occultists as a token of affiliation to a nature-based pagan religion. The pentagram's points symbolize the elements of air, earth, wind, fire, and spirit, important concepts in northern European paganism. Another common indicator of a belief in a nature-based religion, especially witchcraft, is the Egyptian ankh pendant, worn as a symbol of eternal life.

Practitioners of Teutonic religions may wear an upside-down T-shaped "Thor's hammer." This symbol is

used as an overall indicator of Asatru, a name sometimes used for the Teutonic pantheon-based religion.

### Tattoos

Tattoos may be used to indicate Pagan spiritual beliefs. Celtic knotwork and swirls are common designs employed as indicators of a nature-based religion. Tattoos can be utilized as proof of initiation or devotion. For example, some worshippers of Odin may get a tattoo of three interlocking triangles as a sign of their devotion to that Teutonic deity.

### Contemporary Occult Stereotypes

The media generally depicts occultists wearing all-black clothing, especially black robes or cloaks, and having pentacles as jewelry. This stereotypical dress perpetuates the erroneous belief that the occultist is sinful or “evil.”

**“Witch” stereotype.** The “witch” is an enduring stereotype of female occult dress, exemplified by the Wicked Witch of the West from *The Wizard of Oz* and the witch antagonist from various Grimm’s fairy tales. The witch stereotype consists of ragged, all-black clothing, cape, conical wide-brimmed hat, and facial deformities. This stereotype originated in medieval Christianity’s attempt to denigrate practitioners of Western Pagan religions. The color black and physical deformities are associated with the concepts of evil and sin, hence the witch stereotype is “covered” in sin—black clothing and warts. Around the turn of the twenty-first century, the popularity of the *Harry Potter* book series by J. K. Rowling helped to alter the stereotype of the witch, replacing it with more diversified images and connotations.

**Warlock/Satanist stereotype.** The “warlock/Satanist” from cinema, such as those in the 1970s’ *Hammer* horror films, is another Western occult dress stereotype. The male and female Satanist stereotypes typically wear pentacle jewelry, black robes, black hair, and black eyeliner; similar dress is used for the (male) warlock. Since Western cinema has historically dressed the villain archetype in all-black clothing, dressing the occultist in black visually communicates a sinister character to the audience.

### Influences on Contemporary Dress

In the late twentieth century, some occultists wishing to be recognized in mainstream religious and cultural arenas adopted stereotypical occult dress—black robes, pentacle jewelry, black hair, and black eyeliner. While controversial among occult communities, they visually publicized and communicated occult membership and beliefs by wearing this type of dress.

Occult dress has also influenced subcultures. The dark-romantic Goths, some heavy metal music fans “head-bangers,” and a variety of vampire subcultures utilize elements of occult dress, especially stereotypical components, such as black clothing and pentacles. Occult dress styles are more commonly worn by these subcultures as a sym-

bol of subculture affiliation, rather than as an indicator of religious or spiritual beliefs and practices.

See also **Ceremonial and Festival Costumes; Religion and Dress.**

### BIBLIOGRAPHY

- Buckland, Raymond. *Buckland’s Complete Book of Witchcraft*. St. Paul, Minn.: Llewellyn Publications, 1998.
- . *The Tree: The Complete Book of Saxon Witchcraft*. York Beach, Me.: Samuel Weiser, 1985.
- Campanelli, Pauline. *Rites of Passage*. St. Paul, Minn.: Llewellyn Publications, 1995.
- Fitch, Ed. *The Rites of Odin*. St. Paul, Minn.: Llewellyn Publications, 2002.
- Raven Wolf, Silver. *Solitary Witch: The Ultimate Book of Shadows for the New Generation*. St. Paul, Minn.: Llewellyn Publications, 2003.

Thomas A. Bilstad and Theresa M. Winge

**OILSKINS** Oilskin is a heavy cloth that has been made waterproof by being impregnated with a hot solution of oil, gum, and wax to ensure maximum protection under extreme conditions. It has traditionally been made into the foul-weather apparel worn by sailors and fishermen.

Like many pieces of outerwear, the oilskin was born out of necessity. Life upon the high seas was never easy for those on board ship, and sailors devised a number of protective garments to deal with extreme conditions. During the early nineteenth century, it became common for sailors to smear themselves and the clothes they were wearing with oil for protection from the cold and the continuous ocean spray. One sailor at the time, Edward Le Roy, discovered that worn-out sail canvas could be recycled as outerwear. He devised a method of painting the fabric with a mix of linseed oil and wax so that it would become waterproof and suitable to be worn on deck in foul-weather conditions. By the 1830s, the oilskin had become established as essential attire for rough weather at sea for sailors, fishermen, and lifeboat men. The oilskins appeared to have a yellowish hue owing to the linseed oil used to treat them. Overcoats, hats, jackets, and trousers were also produced in this manner. When sailors came to shore they would often still be sporting their oilskin attire, and the wearing of oilskins was adapted for use by people on land. As news of the effectiveness of Le Roy’s new discovery spread, oilskin coats were soon being made by colonists in Australia, and by members of the British army to protect their rifles during rainstorms.

The oilskin coat is often known as a “slicker” in the United States. Oilskin coats and trousers, now made of rubberized or plastic-coated fabric, are still widely worn by fishermen and those in other maritime occupations, and have become standard rainwear for young children. They typically are made in a bright yellow color, echoing the original linseed-oil hue of oilskin itself.



Cattle drovers in Australia developed a version with a fantail to protect the seat of the saddle and leg straps to prevent the coat billowing out or blowing off while riding in the harsh conditions of the outback. The coat, that would become known as the Driza-Bone (the name recalls the dried-out bones of animals often found in the deserts of the outback) also had extended sleeves to protect the wearer's arms when they were extended. Oilskins of this style are still worn by motorcyclists, fishermen, and water-sports enthusiasts alike; the Driza-Bone has become one of the iconic garments of Australia.

The Barbour is another version of an oiled and waxed jacket, the use of which has filtered through to the mainstream. Established in 1894, the Barbour Company's eponymous lightweight coats have become a byword for traditional British oilskins. Ideal for walking, yachting, and fishing, Barbours come in three different weights. The Barbour has also become synonymous with agriculture, owing to its durability, functionality, and most importantly, its warmth and protection from the rain.

Not only do oilskins work as functional pieces of outerwear, they also look as good with a pair of jeans and loafers as they do with working overalls, heavy-duty boots and other protective dress.

See also **Parka**; **Rainwear**.

#### BIBLIOGRAPHY

- Byrde, Penelope. *The Male Image: Men's Fashion in England, 1300–1970*. London: B.T. Batsford, Ltd., 1979.
- Chenoune, Farid. *A History of Men's Fashion*. Paris: Flammarion, 1993.
- De Marley, Diana. *Fashion For Men: An Illustrated History*. London: B.T. Batsford, 1989.
- Schoeffler, O. E., and William Gale. *Esquire's Encyclopedia of 20th Century Fashions*. New York: McGraw-Hill, 1973.
- Wilkins, Christobel. *The Story of Occupational Costume*. Poole, Dorset: Blandford Press, 1982.

*Tom Greatrex*

**OLEFIN FIBERS** Polyethylene and polypropylene are familiar to consumers who recycle as PP, HDPE, and LDPE in disposable plastic items. As fibers, the Federal Trade Commission classifies them as “olefins”; this is also the chemists' term for the ethylene and propylene used to make them. Depending on the way the polymer is made, polyethylene melts at 110° to 135°C (240° to 275°F), while the usual polypropylene melts at around 165°C (330°F). For this reason, the vast majority of olefin fibers are based on polypropylene, and even then, the low melting point is a limitation. Gel-spun polyethylene fibers are distinctly different and are discussed below.

Olefin fibers are cheap. The polymer is melted for extrusion through a spinneret into fiber. Olefin production is a relatively simple operation that small companies

can undertake. Most olefin fibers have a round cross-section. They have strength comparable to nylon and polyester with a fiber tenacity of 5–7g/d (grams per denier). If olefin fibers are stretched or crushed they bounce back well; they have good resilience and recovery properties. Olefin also doesn't absorb moisture, and the fiber is the lightest of all the common fibers. Its g/cc density is 0.92 (grams per cubic centimeter). This means that fabrics of a given bulk are lightweight, and olefin materials float in water. Weather resistance is limited, but stabilizers are added to render this deficiency unimportant in practice. The fiber is undyeable, and while much research has been undertaken to achieve dyeability, few of these modifications have proved commercially successful. For this reason, most colored olefin fibers are produced by the inclusion of pigment in the melt before spinning, in a process commonly called “solution-dyeing” (although it is technically neither a solution nor a dyeing process). The undyeability can also be viewed as inherent stain resistance, and together with the good resilience, abrasion resistance, low density (i.e., good cover for a given weight), and low cost make olefin a realistic alternative to nylon for carpet fiber, and olefin is widely used in upholstery fabrics for the same reasons. The strength is sufficient to make olefin ropes and cords useful, and coupled with low biodegradability and low cost, makes olefin fibers a good choice for geotextile applications.

The lack of moisture absorption translates into “wickability,” and olefin fibers have thus been used for athletic and hiking socks, cold weather underwear, and diaper liners. In many instances, polyester, which also has a very low moisture retention but is dyeable, has taken over those end-uses. Low cost renders the material disposable, and olefin has been used for disposable surgical gowns. It has tended to replace cellulosic fibers such as jute in carpet backing and in sacking.

The technique of gel spinning has been used to produce polyethylene fibers in which the polymer chains are highly aligned along the length of the fiber. One commercial example is sold as Spectra. The excellent alignment gives the material a very high strength, some 3 to 4 times stronger than polyester, and of the same order as para-aramid fibers such as Kevlar. Like Kevlar, it is thus useful in cut protection, ballistic protection, and sailcloth. While the lower weight of olefin is an advantage, the low melting point may be considered a limitation.

See also **Acrylic and Modacrylic Fibers**; **Fibers**; **Techno-Textiles**.

#### BIBLIOGRAPHY

- Adnaur, Sabit. *Wellington Sears Handbook of Industrial Textiles*. Lancaster, Pa.: Technomic, 1995.
- Cook, J. Gordon. *Handbook of Textile Fibers, Part 2: Man-Made Fibers*. 5th ed. Durham, U.K.: Mellow, 1984.
- Moncrieff, R. W. *Man-Made Fibres*, 6th ed. London: Newnes-Butterworth, 1975.

*Martin Bide*



**Women wearing dresses by Japanese designer Chiyo Tanaka.** After World War II, the West showed a re-emergence of interest in other cultures, and Asian designers began to make an impact in the fashion world. © BETTMANN/CORBIS. REPRODUCED BY PERMISSION.

**ORIENTALISM** The Orient has been a source of inspiration for fashion designers since the seventeenth century, when goods of India, China, and Turkey were first widely seen in Western Europe. While the use of the term “Orientalism” has changed over time, it generally refers to the appropriation by western designers of exotic stylistic conventions from diverse cultures spanning the Asian continent.

Though luxury goods have been filtering into Europe from countries like China since ancient times, it was not until the great age of exploration that a wider array of merchandise from cultures throughout Asia found their way to the west. For example, the importation of Chinese ceramics exploded in the seventeenth century. Not only did these wares remain popular for centuries, they also inspired the creation of stellar ceramic compa-

nies like Sevres in France and Meissen in Germany. Even plants, like the legendary flower from Turkey that led to the “tulipmania” craze in Holland and the brewed leaf that became the status drink of the well-to-do and evolved into the ritualized “high tea,” fueled the love of all things from Asia.

It was in the realm of fashion that the impact of “Orientalism” could also be profoundly felt. Platform shoes from central Asia led to the creation of the Venetian chopine in the sixteenth century. Textiles from all over Asia, primarily China, India, and Turkey, inspired the creation of fashions like the *robe à la turquerie* in the eighteenth century. This was a more extraordinary phenomenon since the fear of Turkish Islamic invaders was a constant and imminent threat. Coupled with the threat of an invasion was a diametrically opposed view: the ro-

romantic notion of a far-distant land, such as Cathay (or China), filled with genteel philosophers and lovers of art. This idealized impression of China would continue until the rise of the industrial revolution and European colonialism in the early nineteenth century. The gritty reality of ever-increasing business transactions between East and West, as well as the ever-encroaching military dominance by European powers in Asia was firmly cemented by the middle 1800s.

As Queen Victoria ascended the throne of England 1837, then the most powerful empire in the world, she oversaw an eclectic art style that would come to dominate the remainder of the nineteenth century. The Victorian era brought together many historical European styles of the past, Gothic and Rococo for example, which were sometimes surprisingly combined with elements from cultures like Japan. The end result of one amalgamation, Gothic and Japanese, led to the creation of the Aesthetic Movement. Fashion gowns reflected this blend: smocked robes like medieval chemises were embroidered with asymmetrically placed floral motifs of chrysanthemums, two distinctly Japanese design elements.

The influence of Orientalism on fashion could be seen in many other ways, both frivolous and profound. For example, the fad for harem pants from Turkey appeared in the form of fancy dress costume at balls, just as the Zouave costume of North Africa found its way into the wardrobes of some Southern soldiers fighting in the American Civil War and the closets of European ladies. On the other hand, items of dress from Asia would become essential for women through the mid-nineteenth century. Kashmiri shawls, originally woven in India then exported to the west in the late eighteenth century, became a ubiquitous part of the neoclassical costume. The shawl was often paired with a white columnar dress made of diaphanous, finely woven Indian cotton. Its popularity inspired many weaving companies in Europe to create their version of this essential nineteenth-century wrap, later known as the paisley shawl.

The Orientalism trend reached an apex in the early twentieth century, and the sources for this mania for “all things oriental” ranged from nostalgia for the legends of Persia and Arabia, as popularized by “A Thousand and One Nights,” to the Paris debut of Sergei Diaghilev’s Ballet Russes in 1909. This burst of Orient-inspired creativity in the realm of fashion also had lesser-known sources, including the avant-garde art movement Fauvism and Japanese kimonos made expressly for the western market.

French couturiers, such as Paul Poiret and Jeanne Paquin, were inspired by the Ballet Russes’ performances of “Cléopâtre,” “Schéhérazade,” and “Le Dieu Bleu.” This Russian dance company took Paris by storm with their revolutionary choreography, music, and costume and set designs by the Russian artist Leon Bakst (1866–1924). In addition to these fantastic costume



**Model in Scherrer 2004 haute couture design.** Asian and other ethnic influences began finding their way back into fashion lines in the 1960s and continued to make an impact into the early 2000s. AP/WIDE WORLD PHOTOS. REPRODUCED BY PERMISSION.

shapes and opulent decorative elements, couturiers incorporated the vibrant color palette of Fauve artists such as Henri Matisse. Not only did designers create garments with Orientalist influences, so did the modistes: turbans topped with aigrette or ostrich plumes and secured with jeweled ornaments were paired with either neoclassic columnar gowns or fantastical lampshade tunics.

Clothing created more in the realm of craft by artists such as Mariano Fortuny and Monica Monaci Gallenga also fused historical European and Asian styles into cohesive aesthetic statements. Using silk velvet as a base, both Fortuny and Gallenga precisely incorporated textile patterns from East Asia and the Islamic world for their creations. The importance of craft also fueled the European and American fad for batik cloth. Both the technique for making resist-dyed fabrics like batik and the motifs perfected in cultures like Indonesia were created by artisans on both sides of the Atlantic Ocean in the 1920s.

Marie Callot Gerber (1895–1937), the venerable head of the leading couture house Callot Soeurs, was



another innovator who readily embraced Orientalism. She was inspired by the kimono and created some of the earliest versions of harem pants. From 1910 to the outbreak of World War I, acclaimed beauty and woman of style, Rita de Acosta Lydig, worked with Gerber to create versions of Oriental costumes that were composed of vests made from seventeenth-century needle lace that topped trousers or one-pieced garments that were full and loose over the lower part of the torso before tapering over the calves. Often called the tango dress, after the dance craze imported from Argentina, this style was popularized by couturiers like Lucile (Lady Duff Gordon, 1863–1935) and by fashion illustrators. The house of Callot would go on to lead the 1920s trend for embellishing the columnar dresses of the era with rich embroideries that readily copied Persian and Chinese design elements.

Also influential were exhibitions and expositions geared specifically to exhibit products of France's colonies. One of the first was a major exhibition of Moroccan art installed at the Pavillion de Marsan in March, 1917. The exhibition also forecasted far larger things to come: the Exposition Coloniales, held in Marseilles in 1922 and in Paris nine years later. These shows not only generated public interest in non-Western cultures, but also projected France's commitment to imperialism. According to art historian Kenneth Silver in his publication *Esprit de Corps*, the exposition of 1922 expressed a "less than covert sense of racism." The French were still recovering from the devastating effects of World War I as late as 1925, and there is little doubt that these exhibitions and expositions allowed them to publicly display not only their high position in the modern world, but also their dominance over a vast array of Third World cultures.

Many of the centuries most noted couturiers in France were readily absorbing the influences of the Colonial Expositions of 1922 and 1931. It was the first time that many had direct access to art from such remote countries. This exposure to ethnic dress gave them a far more profound understanding of non-Western dress, primarily objects from Asia. This understanding would enable a few enlightened couturiers to create both new fashion silhouettes as well as imbue their designs with a fundamentally different construction that emphasized the textile rather than complex tailoring.

Marcel Rochas, for example, was directly inspired by dance costumes from the Balinese court, as seen in his broad-shouldered garments of the season immediately following the 1931 Exposition. His "robe Bali," a black silk dress with a broad and square collar trimmed in white pique, is interesting in that it follows the silhouette of a non-Western garment but uses typical European colors and fabrics. Madame Alix Grès also created her version of a Balinese costume in 1937. Jacques Heim designed a sarong-style bathing suit inspired by the Tahitian exhibits in the 1931 Exposition. These sarong suits, in a radical departure from contemporary bathing-suit construction, were made not of knitted wool but with draped woven

cotton. *Harper's Bazaar* made mention of these sarongs and his *pareos* from later collections. By the mid-1930s, Hollywood costumer Edith Head designed a version of the sarong for actress Dorothy Lamour in a series of comedic films starring Bob Hope and Bing Crosby. As noted earlier, all these designers' ethnic-inspired work of this period was not based on non-Western construction techniques, but rather their inspirations came from overall cultural impressions.

The output of "ethnic" garments by fashion designers was to drop off significantly during the 1940s and 1950s as the influence of exotic cultures on fashion had already begun to diminish around 1934. Inspired by the play "The Barrets of Wimpole Street" and the Hollywood film version, couturiers like Madeleine Vionnet, to cite but one of many examples, began to create modern versions of nineteenth-century Western dress. This trend dominated fashion from the late 1930s through the 1950s. The revival of historical styles offered an escape from the pressures of the Great Depression of the 1930s and helped assert the growing sense of nationalism in Europe at that time. Also a factor in the United States was strong anti-Japanese sentiment during and after World War II.

Fashion periodicals of the 1940s, 1950s, and early 1960s seem to indicate only a minimal interest in foreign dress for most designers, as compared with earlier decades. However, a strong revival of ethnic influences arose during the mid-1960s, as the fashion world responded to the purposeful rejection of standard, mass-produced fashion by young people. The young people known as "hippies" ushered in a style noted for its free-form mix of fashion elements from around the world, particularly the Middle East, India, and Native American cultures. Coupled with this renewed interest in non-Western cultures was the emergence of Asian designers. For the first time, Japanese creators like Hanae Mori not only made fashion, they began to influence the work of western designers.

After World War II, other Asian garments began to find their way into the fashion mainstream. One example is the quintessential twentieth-century Chinese dress—the *qipao* or *cheongsam*. This figure-revealing garment worn by a range of urban Chinese women since the mid-1920s has become known in the Western world as the "Suzie Wong" dress, deriving its nickname from the infamous, fictional prostitute in Richard Mason's novel, *The World of Suzie Wong*, published in 1959. Born in the tumultuous years of early Republic China, the *qipao* (meaning "banner gown" in Mandarin) or *cheongsam* (meaning "long dress" in Cantonese) is a true fashion hybrid that fused the elements of traditional Qing Dynasty court dress, Han Chinese costume, and the modern European silhouette. Despite its respectable status in China, Taiwan, and Hong Kong, the *qipao* came to represent in the Occidental mind a two-pronged, stereotypical view of Asian women—subservient, obedient, traditional, on the one hand, and exotic, sexual, even menacing, on the

other. Films such as *Love Is a Many Splendored Thing* (1955) and *The World of Suzie Wong* (1960) are tales filled with textual excess whose narratives featuring Asian-Caucasian sexual liaisons use the *qipao* to uphold and sometimes subvert culturally accepted notions of race.

Perhaps it is those provocative elements of the *qipao* that have made contemporary reinterpretations of it so prevalent in the early twenty-first century. European or American designers, along with Chinese transplants like the New York-based Hong Kong native Vivienne Tam, have been creating their popular versions of Chinese-inspired fashions since the late 1990s. Examples range from the lavishly embroidered Neo-Chinoiserie gowns by John Galiano for Dior, Miuccia Prada's minimalist remake of the Mao jacket, and the body-revealing corseted mini *qipaos* by Roberto Cavalli. It is clear that the continued fascination with Orientalism continues into the twenty-first century.

See also **Japanisme; Qipao.**

#### BIBLIOGRAPHY

- Ames, Frank. *Kashmir Shawl and Its Indo-French Influence*. Woodbridge, U.K.: Antique Collectors Club, 1988.
- Barbera, Annie. Interview by author, Musée de la Mode et du Costume, Palais Galliera: Paris. January 1992.
- Battersby, Martin. *Art Deco Fashion: French Designers 1908–1925*. New York: St. Martin's Press, 1974.
- Beer, Alice Baldwin. *Trade Goods: A Study of Indian Chintz*. Washington, D.C.: Smithsonian Institution Press, 1970.
- Burnham, Dorothy. *Cut My Cote*. Toronto: Royal Ontario Museum, 1974.
- de Osma, Guillermo. *Mariano Fortuny: His Life and Work*. New York: Rizzoli, 1980.
- Druessedow, Jean. Interview by author, Costume Institute, Metropolitan Museum of Art, New York. 18 December 1991.
- Garnier, Guillaume, et al. *Paris Couture Années Trente*. Paris: Musée de la Mode et du Costume, 1987.
- Jon, Paulette. Interview by author. Paris: January 1992.
- Kirke, Betty. *Madeleine Vionnet*. San Francisco: Chronicle Books, 1998.
- Koda, Harold. Interview by author, Fashion Institute of Technology, New York. January 1991.
- Levi-Strauss, Monique. *The Cashmere Shawl*. New York: Harry N. Abrams, 1987.
- Martin, Richard, and Harold Koda. *Orientalism*. New York: Harry N. Abrams, 1994.
- Poix, Marie-Helene. Interview by author, Musée des Arts de la Mode: Paris. January 1992.
- Steele, Valerie, and John S. Major. *China Chic: East Meets West*. New Haven: Yale University Press, 1999.
- Tiel, Vicki. Interview by author: Paris. January 1992.
- White, Palmer. *Poiret*. New York: Studio Vista, 1973.
- Wichmann, Siegfried. *Japanisme: The Japanese Influence on Western Art in the 19th and 20th Centuries*. New York: Harmony Books, 1981.

Patricia Mears

**OUTERWEAR** Outerwear attire is worn over other garments and is generally designed to protect wearers from inclement weather or other adverse environmental conditions, although some outerwear is primarily ceremonial in function. Humans have worn outerwear garments since prehistoric times, but the word “outerwear” has been in use only since the early twentieth century as a general term for this type of clothing. Any garment worn over the day, evening, or work attire of a given period is technically an outerwear garment, with styles ranging from simple shawl-like drapes to jumpsuits that cover the entire body. Fashionable outerwear, however, does not include protective work garments, so this entry focuses only on those outerwear styles worn with regular day or evening clothes.

Although there is no definitive evidence, it seems probable that the first outerwear garments were fur skins used as final body wrap. By the late Paleolithic period (c. 40,000 B.C.E.), skins were being cut and sewn together using bone needles and thread made of animal hair or ligaments. The first sewn outer garments were probably fur capes, designed to fit over the shoulders. This assumption is supported by the existence of wooden “toggle” pieces discovered in European graves of the Magdalenean period (15,000–8,000 B.C.E.), positioned to act as the front closures for a garment worn over the shoulders. In outerwear intended for warmth, the fur was worn next to the body, whereas if the garment's function was primarily ceremonial, the fur was worn outside, as in the leopard skins seen much later in depictions of Egyptian priests of the eighteenth dynasty (1580–1350 B.C.E.).

Just as wraps of fur had done in the earliest societies, lengths of cloth draped or wrapped around the body served as outerwear garments in the early Middle Eastern, Egyptian, Greek, and Roman civilizations. In Greece, both men and women draped a length of fabric called a himation over their tunics. Soldiers wore a short cape called a chlamys, made from a fabric rectangle wrapped around the left arm, and clasped by pins at the right shoulder, leaving the edges open along the right arm. In Rome, the himation became the pallium, and semicircular as well as rectangular fabric pieces were used for capes, as in the *paenula*, which also had a hood. Another ancient outer garment was a poncho-type cape, in which a slit was cut as an opening for the head; the Roman version was called a *casula*.

As noted, capes—sleeveless garments hanging from the shoulders—date back to prehistory with various styles developing over time. In European countries, from the time of Christ to the eighteenth century, capes, cloaks, or mantles—the words are generally used interchangeably—were the primary outerwear garments for both sexes and for all ages and economic classes. These garments were variations on the forms worn since antiquity, and of different lengths and styles depending on the era and/or their



**Frock coats and top hats, ca. 1916.** The men depicted in this poster are wearing frock coats and suits designed by the American Century Clothing Company. Various styles are shown here, including double- and single-breasted “Prince Albert,” as well as one- and two-button frock coats. © HISTORICAL PICTURE ARCHIVE/CORBIS. REPRODUCED BY PERMISSION.

wearers’ rank. For example, wealthy people wore capes lined and trimmed with fur both for extra warmth and as a status symbol. Outerwear garments were also sometimes worn indoors as well as outside, for added protection against the cold in unheated buildings. Ceremonial outerwear, robes of state, and robes for chivalric orders were impressive mantles made of luxurious fabrics and furs.

Occasionally, new garments came into fashion that were part of stylish daywear with an outerwear character, such as the coat-like over-gowns worn by aristocratic men and women in the fifteenth and sixteenth centuries. The men’s gown developed from the long gowns worn by men in the Middle Ages and, by the 1490s, versions were being worn over the new short doublets. The gown was open in front to show the doublet and was typically sleeveless or with short sleeves to reveal the doublet’s sleeves. Portraits of Henry VIII from the 1530s show him wearing flaring, knee-length examples over elaborately slashed doublets. Like the male version, the women’s over-gown was usually open in the front and sleeveless or with short sleeves so that the under-gown and its sleeves would show from beneath. The women’s style was worn in the third quarter of the sixteenth century and originated from the Spanish *ropa*, which itself may have had Oriental origins. Because these gowns were part of current fashion, they were not outerwear in the same sense as capes. The gowns certainly provided additional warmth for their wearers, but, unlike capes, did not afford overall protec-

tion from the elements. For men, the gowns went out of fashion by the 1570s and for women by the 1580s.

Modern fashion trends toward complex clothing styles and rapid style changes, which were set in motion during the Renaissance, did not affect outerwear to any extent until much later. The most significant changes for outerwear took place during the eighteenth and nineteenth centuries, with sleeved coats and jackets slowly superseding capes as the primary outerwear garments for both men and women.

In men’s fashion, this progression begins in the late seventeenth century with a new outerwear garment, the greatcoat, also called a surtout. The origins of the greatcoat are unclear, but it is generally thought that it developed from workmen’s clothing, possibly the *hongerline*, an overcoat worn by French coachmen in the late 1600s. It was the English, however, who popularized the greatcoat, obscuring its working-class beginnings and tailoring it into a fashionable garment. Greatcoats were worn over men’s suits and were cut fuller, looser, and longer than the suit coats they covered. Over the century, as suit coats lost fullness in their skirts and sleeves, so too did greatcoats become more streamlined in cut. By mid-century, greatcoats had also acquired their most distinctive feature—tiers of two or three wide cape-like collars. Although many men still wore cloaks, greatcoats had definitely become the more stylish outerwear option by 1800.

Informal short outercoats, or jackets, were the other important development in men’s outerwear in the eighteenth century. These garments, which had many style variations, also originated from working-class clothing and resembled sleeved waistcoats. Because of their obvious working-class associations, jackets did not become popular among the upper classes until the century’s end. By the 1790s, however, fashionable young men were wearing jackets for hunting. One such style was the spencer, probably named after George John Spencer, second Earl of Spencer, who first sported one of the fitted, waist-length jackets.

Women’s outerwear coats and jackets have their roots in the seventeenth century, when women first adopted elements of male dress for riding. In the late 1600s and early 1700s, the style of women’s riding habit coats and waistcoats were taken directly from men’s suit coats and waistcoats, except that the women’s garments were cut to go over full skirts instead of breeches. At the beginning of the eighteenth century, women’s riding coats were slightly above knee-length and when open, revealed a waistcoat of almost equal length. By mid-century, riding coats had shortened to about hip length, becoming fitted jackets, and riding habits were regarded as outerwear suitable for both riding and traveling. Women also wore a variety of jacket-style bodices for informal daywear; however, unlike riding habit jackets, these garments were not considered outerwear.



Another garment patterned after menswear, in this case the greatcoat, came into fashion for women in the late 1770s. Called a riding greatcoat or redingote, this garment was a floor-length coatdress with a fitted bodice and long, fitted sleeves. Many variations of this style were worn into the 1790s, some with the skirt attached only at the bodice back or to its sides, revealing a decorative petticoat in front. In spite of its name, the redingote was not intended for riding; it was an informal day dress that was also acceptable as outerwear for walking or traveling. At the end of the century, shawls, especially fine woolen examples imported from India, came into vogue as decorative indoor-outdoor accessories. Despite these innovations, capes persisted as the main outerwear garment for women, especially during very inclement weather.

In the nineteenth century, rapid changes in women's dress determined whether capes, coats, jackets, or shawls were the fashionable outerwear choices at any given time. While capes continued to be worn throughout the century, shawls, coats, or jackets were sometimes more in vogue than the time-honored cape. This was especially true in the early nineteenth century when shawls and innovative jacket and coat styles predominated over capes. The most important new fashions were the spencer jacket, charmingly adapted from menswear for the narrow, high-waisted dresses of this period, and long overcoats, called pelisses, that mimicked the neoclassical silhouette of the dresses beneath.

Capes resumed their former importance by 1830 because capes were more accommodating than jackets or coats over dresses whose sleeves had ballooned into the leg-of-mutton style. Even after sleeves deflated in the mid-1830s, capes, styled in a myriad of new designs, continued as the dominant women's outerwear garments for the next thirty years. Shawls were also popular for daywear into the 1860s, especially large ones with paisley designs. Jackets again came into vogue in the 1850s and 1860s, including fashions with fur-trimmed, fitted bodices and knee-length full skirts for winter and short summer styles that flared out over hooped skirts. It was also in this period that fur garments with the fur on the outside, not as a lining, were introduced. Another jacket fashion, the dolman, was cut to accommodate the bustles of the 1870s and 1880s. Although not as popular as jackets, full-length coats were worn from the 1870s to the early 1890s, later losing favor to capes during the mid-1890s revival of the leg-of-mutton sleeve. Throughout the century, muffs and tippets, fur or fur-trimmed neck wraps, accessorized stylish outerwear.

For men, the greatcoat continued as the most fashionable outerwear option until the 1840s. New styles appeared in mid-century, including the Inverness coat, a loose coat with an arm-length cape; and the paletot, a boxy, thigh-length jacket. From the 1830s to the 1890s, when men wore suits consisting of a skirted frock coat, a waistcoat, and trousers, the frock coat, although it was technically daywear, could also serve as outerwear except

in severe weather. By the 1890s, the sack suit was replacing the frock suit for daywear and the sack suit jacket (the forerunner of modern men's suit jackets) was effective as lightweight outerwear. The winter overcoat of choice over both frock coats and sack suits was the Chesterfield, a topcoat cut similarly to a frock coat but longer, looser, and without a waist seam. Capes went out of style early in the century for daywear but endured as outerwear over formal evening wear.

Wool or fur outerwear provided significant protection from the cold for centuries, but similarly effective protection from rain was only made possible by technological advances in the nineteenth century. In 1823, Charles Macintosh, a Scottish chemist, patented the first viable waterproof fabric, consisting of two pieces of wool cemented together by rubber dissolved in coal-tar naphtha. This invention had great potential but had the serious drawbacks of becoming stiff in cold weather and sticky in hot. These problems were resolved when vulcanized rubber was invented in 1839 and Macintosh produced the first practical raincoats; in England, Macintosh or "Mac" raincoats are still worn today. From the mid-nineteenth century to today, further technological developments have led to man-made materials with increasingly effective waterproof and heat-retention properties, such as vinyl rainwear and acrylic furs.

Many forces shaped twentieth-century outerwear fashions. As in earlier centuries, the day and evening attire worn under the outerwear affected the look and cut of the overgarments, but sports, ethnic influences, the development of unisex styles, and new materials also played important roles. After centuries of predominance, capes were no longer the most ubiquitous outerwear garments. Men continued to wear capes for evening wear until mid-century, and women's capes were produced for both day and evening wear, but by the 1920s, capes constituted only a very minor part of the outerwear market. Throughout the century, the most basic outerwear options for both sexes were single- and double-breasted overcoats with notched collars. The men's versions often resembled their nineteenth-century precursors, while women had more diverse choices—coats fashioned in bright colors, new materials, and with contemporaneous style details such as padded shoulders.

Primarily worn by women, twentieth-century fur outerwear had a checkered record. Fur was a luxury item in the early 1900s, but fur and fur-trimmed garments became more affordable by mid-century due to the mass marketing of cheaper furs. In the 1960s, there was a fad for "fun furs"—inexpensive pelts, made up into a variety of trendy jackets and coats. However, escalating labor and material costs, plus the concerns of animal-rights activists, led to price increases and lessened popularity of real fur garments by the 1990s. Fortunately, refinements in man-made furs have allowed fur to continue its long-standing role in outerwear fashion.

## OXFORD MONK'S CLOTH

The proliferation of new jacket styles for both sexes was the most significant outerwear development during the twentieth century. Whether ethnic-influenced anoraks and parkas, military-influenced pea and bomber jackets, or tailored blazers derived from men's suits, jackets are indispensable and versatile additions to everyone's outerwear wardrobe.

See also **Blazer; Coat; Duffle Coat; Jacket; Parka; Rainwear; Windbreaker.**

### BIBLIOGRAPHY

There are no definitive secondary sources focusing on outerwear in all its forms. For a study of outerwear, general histories of dress plus histories of clothing in specific periods must be consulted. Some of the more helpful texts are included below.

Ashelford, Jane. *The Art of Dress: Clothes and Society, 1500–1914*. London: The National Trust Enterprises Limited, 1996. History of fashionable dress in which outerwear is regularly mentioned and illustrated.

Ashelford, Jane, ed. *The Visual History of Costume: The Sixteenth Century*. London: B.T. Batsford, Ltd., 1993.

Boucher, Francois. *20,000 Years of Fashion: The History of Costume and Personal Adornment*. New York: Harry N. Abrams, 1987. General history of costume in which outerwear garments are mentioned for each period from prehistory to 1947.

Ewing, Elizabeth. *Fur in Dress*. London: B.T. Batsford, Ltd., 1981. Provides a good overview of fur and fur-trimmed outerwear from prehistoric times to the 1970s.

The Visual History of Costume Series: *The Nineteenth Century* (Vanda Foster, 1984). London: B.T. Batsford, Ltd. Presents images with commentary on the clothing of the people in the pictures. Several images in each book depict outerwear.

Colleen R. Callaban

**OXFORD MONK'S CLOTH.** See **Weave, Plain.**



**PAGNE AND WRAPPER** The wrapper, called by the French word *le pagne* in Francophone West African countries, is a cloth about 59 inches by 98 inches (150 cm by 250 cm). In its main use, it is wrapped around the hips and rolled over on itself at the waist to form a skirt. Worn throughout West and Central Africa, it belongs to that large class of clothing that is not sewn but wrapped around the body. Found the world over, this class includes the sarong, kain, kanga, sari, shuka, and toga. Although traditionally made of strip or broadloom handwoven cloth, wrappers can also be made of hand-dyed or factory-printed cotton, as well as silk and rayon.

#### Gendered and Ethnic Styles

In the seventeenth and eighteenth centuries, men wore wrappers, but by the twentieth century, they became, with a few notable exceptions, exclusively women's wear. Exceptions to this gender rule are certain ethnic groups, including the Kalabari, of Nigeria. Here men's formal dress includes an ankle-length wrapper worn with a long or short shirt, depending on one's rank. The outfit is topped with a bowler hat.

As women's wear, the wrapper usually comes to the ankle, but is worn with different upper garments in Francophone and Anglophone countries of West Africa. In Senegal and the neighboring Francophone countries Mali, Guinea, and Benin, the *pagne* is worn with elegant long garments, the *grand boubou* or a long, loose dress called the *ndoket*. A head-tie finishes the outfit. While these long garments hide most of the *pagne*, it is also worn with short garments: a loose blouse with puffed sleeves called the *marinière*, or a fitted top with a flounce at the hip and puffed sleeves called the *taille basse*. One graceful style in these countries is the two wrap or *deux pagnes*. With a *marinière* and one *pagne* worn as a long skirt, the second, matching *pagne* is wrapped tightly around the hips and tied.

#### Historical Changes in Style

In the early part of the twentieth century, when Senegalese women wore their *boubous* hip or knee length, the *pagne* was a stronger visual focus for both the aesthetics and the symbolism of dress. Cloth was a major form of wealth, as well as a principal medium of artistic expression. In order to show their status and taste, Senegalese

women wore three *pagnes*, layered in three different lengths. The three contrasting *pagnes* were made of handwoven, hand-dyed, and factory-printed fabrics. After World War II, the *grand boubou*, reaching almost to the ankles, came into fashion for women. The *pagne*, almost hidden, became less of a focal point. In the latter part of the twentieth century, elegant fashion demanded a single *pagne* of the same fabric as the boubou and head-tie, either richly dyed or in Holland wax.

#### Differences in Use of the *Pagne*

In Nigeria, where the upper garments are usually short, and where weaving and dyeing are complex arts, the wrapper has retained its strong visual focus in the over-all outfit. Luxurious, handwoven either on strip looms or broad looms, intricately dyed with resist patterns, or in solid colors of rich silk, wrappers, called *Iro*, can be used in many styles. For elegant occasions they can be worn with a short overblouse of rich fabric, often of lace. In several ethnic groups, women dress for ceremonial occasions in a style called "up and down." For this outfit, two matching cloths are wrapped around the body, one at the waist, the other under the arms. They can also be wrapped at the waist, one knee length and one ankle length. In addition, urban women in Nigeria can adopt a style in which a handwoven wrapper is gathered around the middle of the body over a Western dress. The outfit is topped with a matching head-tie.

This overwrapper style differs from the *deux pagnes* in a way that epitomizes the differences in culture, nationality, and age. The overwrapper is a form of elegance worn by older married Nigerian women to demonstrate their wealth and social position, and is tied loosely around the waist to show off the expensive, heavy cloth, woven in stripes. The *deux pagnes* or two wrapper, by contrast, is made of either dyed or factory-printed cotton cloth that is lightweight, more supple, and clings to the body. The style is worn in West and Central Africa by younger women, whose body contours, graceful carriage, and swaying gait show themselves to good advantage in the tightly wrapped second *pagne*.

#### Cultural and Sexual Symbolism of *Pagnes*

In Senegal, a second, knee-length *pagne*, called in Wolof a *bethio*, is worn as an underskirt and seen only in intimate



meetings with a lover or husband. A focus of erotic fantasy and innuendo, the *bethio* plays a strong role in the art of seduction, for which Senegalese women are famous. It is also a product of women's craft. Usually in solid colors, and often white, the *bethio* is made of various hand-worked fabrics. One such fabric is a factory silk, or more often polyester, with hand-cut eyelet patterns and silver or gold embroidery. Another fabrication is made of percale, hand embroidered with heavy thread in bright colors. For a third fabrication, women crochet the *bethio* in fine yarn.

But most important, the *pagne* or wrapper, as an endlessly versatile piece of cloth, is symbolically fundamental to human culture itself. In Wolof, the principal African language of Senegal, the word for *pagne* is *séru*, which means simply "cloth." When a child is born, it is immediately wrapped in a *pagne*, and as an infant it is carried on its mother's back in a *pagne* wrapped around her upper body. When a woman in Senegal marries, her friends veil her head in a *pagne* before they take her on her journey to her husband's house. When a person dies, he or she must be wrapped in a white percale *pagne*. A symbol of wealth, sexuality, birth, death, and marriage, the *pagne* is a rich focus of visual aesthetics and multiple meanings.

See also **Africa, Sub-Saharan: History of Dress; Boubou.**

#### BIBLIOGRAPHY

- Boilat, P.-David. *Esquisses sénégalaises; physiologie du pays, peuplades, commerce, religions, passé et avenir, récits et légendes*. Paris: P. Bertrand, 1853.
- Eicher, Joanne Bubolz. *Nigerian Handcrafted Textiles*. Ile-Ife, Nigeria: University of Ife Press, 1976.
- Eicher, Joanne Bubolz, and Tonye V. Erekosima. "Why Do They Call It Kalabari? Cultural Authentication and the Demarcation of Ethnic Identity." In *Dress and Ethnicity: Change across Space and Time*. Edited by Joanne B. Eicher. Oxford: Berg, 1995.
- Heath, Deborah. "Fashion, Anti-Fashion, and Heteroglossia in Urban Senegal." *American Ethnologist* 19, no. 2 (1992): 19–33.
- Mustafa, Huda Nura. "Sartorial Ecumenes: African Styles in a Social and Economic Context." In *The Art of African Fashion*. Edited by Els van der Plas and Marlous Willemsen. Eritrea: Africa World Press (1998).
- Perani, Judith, and Norma H. Wolff. *Cloth, Dress and Art Patronage in Africa*. New York: Berg, 1999.
- Picton, John, and John Mack. *African Textiles*. New York: Harper and Row, 1989.
- Picton, John, Rayda Becker, et al. *The Art of African Textiles: Technology, Tradition, and Luxe*. London: Barbican Art Gallery; Lund Humphries Publishers, 1995.
- Rabine, Leslie W. "Dressing Up in Dakar." *L'Esprit créateur* 37, no. 1 (1997): 84–107.
- . *The Global Circulation of African Fashion*. Oxford: Berg, 2002.

Leslie W. Rabine

**PAILLETTES.** See **Spangles.**

**PAISLEY** The paisley pattern, though derived from Kashmir shawls and their European imitations, is a variant of an ancient and versatile design theme. The teardrop, or elongated oval with one end tapering to a point, can be traced back to Pharaonic, Chaldean, and Assyrian stone carvings, ancient Greek ceramics, and medieval Coptic, Central Asian, and European textiles. It features variously as lotus bud, tree-of-life, ivy or acanthus leaf, cone, palm frond or cypress, occasionally with the bent-over tip that is the paisley's defining characteristic.

As we know it today, however, the paisley emerged much later, in the shawl design of Kashmir, and perhaps contemporaneously in Persia, in the *termeh*, the woven shawls of Meshad, Kerman, and Yazd. It developed out of the single, somewhat naturalistic bloom, a restrained and graceful form that in the seventeenth century became the favorite motif of Mughal courtly art. Applied to the shawl fabrics for which Kashmir and Persia were already famous, the single flower evolved into a bush, or a bouquet of flowers, growing ever more elaborate and stylized. By about the second half of the eighteenth century, it assumed its characteristic shape, becoming, in myriad variations, the predominant motif of shawl design. In Kashmir it is usually called *buta* (Persian *boteh*, a shrub); and one version is still called *shah-pasand*, or "emperor's favorite," indicating that royal patronage may have played some part in popularizing it. It was quickly incorporated in textile design elsewhere in India, where it is known as *kalgi* or *kalga* (plume), *badam* (almond), or *ambi* (mango).

By the end of the eighteenth century, imported Kashmir shawls had become high fashion in Europe—as accessories to women's attire rather than shoulder mantles for men, Indian-style. British entrepreneurs started experimenting with "imitation Indian shawls" in the last decades of the century, first in Edinburgh, then in Norwich, copying or adapting the Kashmir designs.

As demand grew, Edinburgh shawl manufacturers started outsourcing work to Paisley which, as home to a long-established textile industry, had a pool of skilled weavers capable of drawing on the experience of Norwich, Edinburgh, and various shawl-manufacturing centers in France, and could take advantage of technological developments, particularly the Jacquard loom. This adaptability, together with good management and easy access to imported raw materials through the ports of the Clyde made Paisley shawls so competitive that in time they eclipsed those of the other British centers. By the mid-nineteenth century, in the English-speaking world, the term "paisley" had become synonymous with shawls, and by extension with the *buta* design, whether used on shawls or elsewhere.

The paisley retained its popularity even after the shawl fashion came to an end in the 1870s, partly due to

the famous London store Liberty's, many of whose trademark printed fabrics used designs derived from shawl-pattern books. In the twenty-first century, it features textiles destined to be made up into clothes—from saris and shawls in India to dresses, ties, and scarves in the West—as well as on furnishing materials, bone china, and indeed almost any item that calls for a “traditional” form of decoration. Its popularity has endured across the board, from high fashion to high-street kitsch (especially in Scotland). But it does seem a pity that it has come to be known by the name of a town whose weavers—though responsible for popularizing it—made no significant contribution to its development, rather than by any of the names indigenous to the region where it originated.

See also **Asia, South: History of Dress; Cashmere and Pashmina; Shawls.**

#### BIBLIOGRAPHY

- Ames, Frank. *The Kashmir Shawl*. Woodbridge, U.K.: Antique Collectors' Club, 1986; 2nd ed., 1997.
- Claburn, Pamela. *Shawls*. Risborough, U.K.: Shire Publications, 2nd ed., 2002.
- Falke, O. von. *Decorative Silks*. London: B.T. Batsford, Ltd., 1922.
- Reilly, Valerie. *Paisley Patterns: A Design Source Book*. London: Studio Editions, 1989.
- Rosbach, Ed. *The Art of Paisley*. New York and London: Van Nostrand Reinhold Company, 1980.
- Skelton, Robert. “A Decorative Motif in Mughal Art.” In *Aspects of Indian Art*. Edited by P. Pal. Leiden: Brill, 1972.

*Janet Rizvi and Jasleen Dhamija*

**PAJAMAS** Pajamas are a garment for sleeping or lounging worn by men, women, and children. Pajamas may be one-piece or two-piece garments, but always consist of loosely fitting pants of various widths and lengths. While pajamas are traditionally viewed as utilitarian garments, they are often a reflection of the fashionable silhouette and the image of the exotic “other” in popular imagination.

The word pajama comes from the Hindi “pae jama” or “pai jama,” meaning leg clothing, and its usage dates back to the Ottoman Empire. Alternate spellings include: paejamas, pajamas, pyjamas, and the abbreviated pj's. Pajamas were traditionally loose drawers or trousers tied at the waist with a drawstring or cord, and they were worn by both sexes in India, Iran, Pakistan, and Bangladesh. Pajamas could be either tight fitting throughout the entire leg, or very full at waist and knees with tightness at calves and ankles. They were usually worn with a belted tunic extending to the knees. Although the word is Hindi, similar garments are found in traditional costume throughout the Middle and Far East.

Pajamas were adopted by Europeans while in these countries, and brought back as exotic loungewear. Although the wearing of pajamas was not widespread until

the twentieth century, they were appropriated as early as the seventeenth century as a signifier of status and worldly knowledge.

#### Pajamas as Sleepwear

Pajamas are generally thought to have been introduced to the Western world about 1870, when British colonials, who had adopted them as an alternative to the traditional nightshirt, continued the practice upon their return. By the end of the nineteenth century, the term *pajama* was being used to describe a two-piece garment: both the pajamas (trousers) and the jacket-styled top worn with them.

By 1902, men's pajamas were widely available alongside more traditional nightshirts and were available in fabrics like flannel and madras and had lost most of their exotic connotations. Pajamas were considered modern and suitable for an active lifestyle. The advertising copy in the 1902 *Sears, Roebuck Catalogue* suggested that they were: “Just the thing for traveling, as their appearance admits a greater freedom than the usual kind of nightshirts” (p. 966).

The streamlined, often androgynous fashions during the 1920s helped to popularize the wearing of pajamas by women. While men's pajamas were invariably made of cotton, silk, or flannel, women's examples were often made of brightly printed silk or rayon and trimmed with ribbons and lace. Early examples featured a raised or natural waist with voluminous legs gathered at the ankle in a “Turkish trouser” style, while later examples featured straight legs and dropped waists, a reflection of the 1920s silhouette. Throughout the century, pajamas would continue to reflect the fashionable ideal. The 1934 film *It Happened One Night*, which featured a scene in which Claudette Colbert wears a pair of men's pajamas, helped to popularize the menswear-styled pajama for women.

By the 1940s, women were wearing “shortie” pajamas, which would later develop into the “baby doll” pajama. The typical baby-doll pajama consisted of a sleeveless smock-style top with a frill at the hem, and balloon panties frilled at the leg openings. By the mid-1960s, baby-doll pajamas were standard summer nightwear for millions of girls and women.

With the popularity of unisex styling during the 1970s, pajamas were often menswear inspired. Tailored satin pajamas had been popular since the 1920s but were rediscovered during this period by both men and women. In this decade, ethnic styles based on the traditional dress of Vietnam and China were worn as antifashion and a statement about the wearer's political views. This trend toward unisex and ethnic remains to this day and is particularly apparent in women's fashions, where the division between dress and undress has become blurred.

#### Pajamas as Fashion

This blurring of these boundaries began long ago. Women had begun experimenting with the adaptation



**Claudette Colbert in men's-style pajama, 1934.** In the 1934 film comedy *It Happened One Night*, actress Claudette Colbert dons a pair of men's-style pajamas in a bedroom scene with Clark Gable. This famous scene popularized the men's pajama look among women. © BETTMANN/CORBIS. REPRODUCED BY PERMISSION.

of pajama-style trousers since the eighteenth century, but this was associated with masquerade costume, actresses, and prostitution, not with respectable women. In 1851, Amelia Jenks Bloomer (1818–1894), an American feminist, adopted voluminous “Turkish trousers” worn with a knee-length skirt as an alternative to fashionable dress. The response to her appearance was overwhelmingly negative, and the “Bloomer Costume” failed to gain acceptance.

Pajamas began to be adapted into fashionable dress in the early years of the twentieth century when avant-garde designers promoted them as an elegant alternative to the tea gown. French couturier Paul Poiret launched pajama styles for both day and evening as early as 1911, and his influence played a large role in their eventual acceptance.

Beach pajamas, which were worn by the seaside and for walking on the boardwalk, were popularized by

Gabrielle “Coco” Chanel in the early 1920s. The first beach pajamas were worn by the adventuresome few, but by the end of the decade had become acceptable dress for the average woman. Evening pajamas, intended to be worn as a new type of costume for informal dining at home, also became widely accepted during this decade. Evening pajamas would remain popular throughout the 1930s and would reemerge in the 1960s in the form of “palazzo pajamas.”

Palazzo pajamas were introduced by the Roman designer Irene Galitzine in 1960 for elegant but informal evening dress. They greatly influenced fashion during the 1960s and continued into the casual 1970s. Palazzo pajamas featured extremely wide legs and were often made of soft silk and decorated with beading and fringe. During the 1970s, eveningwear and loungewear merged, as evening styles became increasingly simple and unstructured. Halston was particularly known for his bias-cut



pantsuits of satin and crepe, which he referred to as “pajama dressing.” In light of this, popular magazines suggested readers shop in the lingerie departments for their eveningwear.

This increased informality of dress has made the evening pajama a staple in modern fashion, and the Asian influence on designers like Ralph Lauren and Giorgio Armani has blurred the boundaries between dress and undress even further. It is likely that this trend will continue well into the twenty-first century.

See also **Lingerie; Trousers; Unisex Clothing.**

#### BIBLIOGRAPHY

- Calasibetta, Charlotte. *The Fairchild Dictionary of Fashion*. New York: Fairchild Publications, 1983.
- Ewing, Elizabeth. *History of Twentieth Century Fashion*. Lanham, Md.: Barnes and Noble Books, 1992.
- Gross, Elaine, and Fred Rottman. *Halston: An American Original*. New York: HarperCollins Publishers, 1999.
- Kidwell, Claudia Brush, and Valerie Steele. *Men and Women: Dressing the Part*. Washington, D.C.: Smithsonian Institution Press, 1989.
- Probert, Christina. *Swimwear in Vogue since 1910*. New York: Abbeville Press, 1981.
- Sears, Roebuck Catalogue, 1902 Edition*. New York: Gramercy Books, 1993 (reprint).
- Wilcox, R. Turner. *The Dictionary of Costume*. New York: Macmillan Publishing Company, 1969.
- Yarwood, Doreen. *The Encyclopedia of World Costume*. New York: Charles Scribner's Sons, 1978.

Clare Sauro

**PANNIERS.** See **Skirt Supports.**

**PANTIES** Underpants or drawers, known colloquially as “panties,” were first worn during the Renaissance for function but were also used as a chastity device. They were described at the time as “helping women keep clean and protecting them from the cold, they prevent the thighs being seen if they fall off a horse. These drawers also protect them against adventurous young men, because if they slip their hands under their skirts they can't touch their skin at all” (Saint-Laurent, p. 65). As a result of their direct contact with the female genitals, underpants were considered the most risqué of garments, so much so that it was considered almost more immodest to wear them than not, as they not only concealed but also drew attention to the vagina. Thus, until the mid-nineteenth century, they were primarily worn by prostitutes and by little girls.

By 1841, however, *The Handbook of the Toilet* suggested that French drawers were “of incalculable advantage to women, preventing many of the disorders and

indispositions to which ... females are subject. The drawers may be of flannel, calico, or cotton, and should reach as far down the leg as possible without their being seen” (Carter, p. 46). Underpants were variously known as drawers, knickers (derived from the original knickerbocker), smalls, britches, and step-ins. Nineteenth-century drawers were designed so that each leg of the garment was separate and the crotch was either open or sewn closed. By the end of World War I, as skirts became shorter, underpants became scantier. Thus in the 1920s, underpants were much smaller than in the nineteenth century.

Outside the realm of erotica and the burlesque theater, underpants were intended to be hidden garments. During the Wimbledon Tennis Championships in 1949, tennis player Gertrude Moran took to the court wearing a short tennis dress, designed by Teddy Tinling, that revealed a pair of ruffled lace-trimmed knickers. This apparel made headlines around the world as a very daring fashion statement. One of the seminal panty moments of post-World War II film saw Marilyn Monroe revealing her underpants when a draft from a subway grating blew up her skirt in the film *The Seven Year Itch* (1955).

The 1960s saw the development of matching bra and brief sets, disposable paper panties, and the bikini brief. In the 1990s, a new fashion for thong underwear became popular. More recently, boy-style underwear briefs have come into fashion for women. By the 1990s the meaning of panties had completely changed. Previously they had to be hidden at all costs but in this decade it became fashionable to wear big waist high pants under the transparent outerwear designs of Gianni Versace or Dolce & Gabbana. The deliberately non-sexual look of the pants diffused the potential vulgarity of the clothes above.

See also **Brassiere; Lingerie; Underwear.**

#### BIBLIOGRAPHY

- Carter, Alison. *Underwear: The Fashion History*. London: B.T. Batsford, Ltd. New York: Drama Book Publishers, 1992.
- Chenoune, Farid. *Beneath It All: A Century of French Lingerie*. New York: Rizzoli, 1999.
- Saint-Laurent, Cecil. *The Great Book of Lingerie*. London: Academy Editions, 1986.

Caroline Cox

**PAPER DRESSES** The paper dress enjoyed a brief but lively vogue in the late 1960s as a novelty fashion item. A simple, above-the-knee length chemise, constructed from nonwoven cellulose tissue reinforced with rayon or nylon, the inexpensive “paper” garment featured bold printed designs and was meant to be discarded after a few wearings.

Individual paper clothes and accessories existed as early as the nineteenth century, when paper was especially popular for masquerade costumes. The first modern paper

dress is credited to the Scott Paper Company of Philadelphia, which introduced it as a 1966 mail-in promotion. Consumers were invited to send in a coupon from a Scott product, along with \$1.25, in order to receive a “Paper Caper” dress made of Dura-Weve, a material the company had patented in 1958. The dress boasted either a striking black-and-white Op Art pattern or a red bandanna print. Scott’s sales pitch underscored its transience: “Won’t last forever...who cares? Wear it for kicks—then give it the air.”

The campaign was unexpectedly successful, generating 500,000 shipments and stimulating other manufacturers to promote paper garments. Within a year of Scott’s promotion, paper fashions were on sale in major department stores. Some, such as Abraham & Strauss and I. Magnin, created entire paper clothing boutiques. At the height of the craze, Mars Hosiery of Asheville, N.C., was reportedly manufacturing 100,000 dresses a week.

A big factor in the appeal of the dresses was their eye-catching patterns—daisies, zigzags, animal prints, stripes—that suggested Pop Art. Some imagery made the dresses akin to walking billboards, showcasing ads for *Time* magazine, Campbell’s Soup cans, political candidates, and poster-sized photographs. Fun and fashion-forward, the dresses could be hemmed with scissors or colored with crayons. And, at about \$8 apiece they were affordable, inspiring *Mademoiselle* magazine editors to exclaim in June 1967: “The paper dress is the ultimate smart-money fashion” (p. 99).

Modern, whimsical, and disposable, paper garments captured the 1960s zeitgeist. It was a time when new industrial materials like plastics and metallic fibers were making inroads, Rudi Gernreich and Paco Rabanne were pushing the limits of clothing design, and the post-World War II baby boomers were in the throes of a vibrant youth culture centered on fashion and music. Consumers accepted the notion of cheap, throwaway clothing as they embraced disposable cutlery, plates, razors, napkins, lighters, and pens. The fashion press even predicted that paper garments might take over the marketplace.

Instead, by 1968 paper dresses had lost their currency. Wearers found they could be ill-fitting and uncomfortable, the printed surfaces could rub off, and there were concerns about flammability and excessive post-consumer waste. Plus, they had simply lost their cutting-edge appeal due to overexposure.

However, the dresses’ paperlike cellulose fabric was adapted as a practical and lightweight material for disposable garments for hospital and factory workers. And the legacy of the 1960s paper dress continues to inspire contemporary fashion designers like Yeohlee and Vivienne Tam, whose spring 1999 collection featured a line of clothes constructed from DuPont Tyvek, the reinforced paper used in overnight mail envelopes.

See also **Fads; Gernreich, Rudi; Rabanne, Paco.**

#### BIBLIOGRAPHY

Palmer, Alexandra. “Paper Clothes: Not Just a Fad,” In *Dress and Popular Culture*. Ohio: Bowling Green State University Popular Press, 1991, pp. 85–105.

“Paper Profits.” *Mademoiselle* June 1967, 99–101.

Szabo, Julia. “Pulp Fashion Continues to Inspire,” *New York Daily News*, May 30, 1999.

#### Internet Resources

“Paper Dress, 1966.” Available from <<http://www.consumerreports.org>>.

Kimberly-Clark. “1966, The Paper Caper Dress.” Available from <[http://www.kimberly-clark.com/aboutus/paper\\_dresses.asp](http://www.kimberly-clark.com/aboutus/paper_dresses.asp)>.

*Kathleen Paton*

**PAQUIN, JEANNE** Jeanne Paquin (1869–1936) was the first woman to gain international celebrity in the fashion business. Her design career spanned the three decades from 1891 to 1920. She was born Jeanne Marie Charlotte Beckers in l’Ile Saint-Denis, on the outskirts of Paris. As a young girl she was employed at a local dressmaker’s shop and then became a seamstress at the distinguished Parisian firm of Maison Rouff. In February 1891 she married Isidore Rene Jacob *dit* Paquin (legally changed to Paquin in 1899), a former banker and businessman. One month before their marriage he founded the House of Paquin at 3, rue de la Paix, where for two years prior he was a partner in a couture business under the name of Paquin Lalanne et Cie. Creating a new business model, with Madame as head designer and her husband as business administrator, the couple built a couture business whose worldwide scope and stylistic influence were unparalleled during the early years of the twentieth century. Their innovative approaches to marketing and youthful yet sumptuous design aesthetic attracted fashionable women of the world who were poised for a new fashion image at the end of the Victorian era. The diverse and prestigious client list included famous actresses and courtesans, European royals, and the wives of American business tycoons such as Rockefeller, Astor, Vanderbilt, Ballantine, and Wannamaker. At its height the house employed more than two thousand workers, surpassing even the house of Worth. In 1907 Isidore Paquin died suddenly, leaving Jeanne Paquin to head their fashion empire alone. Her half brother, Henri Joire, and his wife, Suzanne, joined her as partners in 1911. She retired in 1920 and eleven years later married Jean-Baptiste Noulens, a French diplomat. The House of Paquin remained open under a series of designers, until it merged with Worth in 1954. Worth-Paquin closed in 1956.

#### Business Innovations

Astute and inventive in their approaches to doing business, the Paquins originated practices that later became standard operating procedures in the fashion world. Most

sweeping was the concept of international expansion through opening foreign branches. In 1896 the house opened a full-scale branch in London, the first of its kind, where designs from the Paris house were produced in ateliers on the local premises. A branch in Buenos Aires and a fur establishment in New York followed in 1912, and a final branch opened in Madrid in 1914.

The Paquins also took bold initiatives in the areas of client relations and marketing. From the very beginning, in contrast to the aloof approach of their contemporaries, the Paquins developed personal relationships with their clients that addressed their individual personalities and scheduling needs. Harnessing from the outset the power of glamour and entertainment to promote clothing, they sent beautiful young actresses to the opera and the races dressed in their newest models, several often wearing the same dress. Later, Madame introduced all-white ballet finales at her fashion shows, and in 1913 produced “dress parades” of dresses designed specifically for dancing the tango at the popular “Tango Teas” held on Monday afternoons at the palace in London. In 1914 she sent her entire spring collection on an American tour, which included New York, Philadelphia, Boston, Pittsburgh, and Chicago. The fashions were modeled by Paquin’s own mannequins who astonished the public by wearing mauve and pink wigs on the street.

### Personal Image and Acknowledgments

Beautiful, chic, intelligent, and charismatic, Paquin was herself the best publicist for her own style. She always wore her own designs, and, widely admired by the public, was the first woman to become a fashion icon, establishing the precedent for Gabrielle Chanel. Equally acclaimed for her business skills, she received numerous awards and appointments, all firsts for a woman in her time. In 1900 her fellow couturiers selected her to head their first collective public display of couture at the great Paris Universal Exposition. She was awarded the Order of Leopold II of Belgium in 1910 and the prestigious Légion d’honneur in the field of commerce in 1913, and was elected president of the *Chambre syndicale de la couture*, the official organization of Parisian couturiers, in 1917.

### Clothing Designs and Artistic Hallmarks

The house offered a full range of garments that included fashions for all occasions—chic *tailleurs* (suits) for day wear; extravagant outerwear, especially evening wraps; and sporting clothes, which were sold in a special department opened in 1912 at the London branch. Opulent furs and fur-trimmed garments were always a specialty. Paquin clothes were renowned for their imaginative design, superb craftsmanship, and incomparable artistry. A brilliant artist and colorist, Paquin created breathtaking visual effects with color, light, texture, and tonal nuance that ranged from an ethereal luminescence in the filmy, pastel dresses fashionable from 1900 to 1910, to a bold vibrancy in the Oriental-inspired creations that

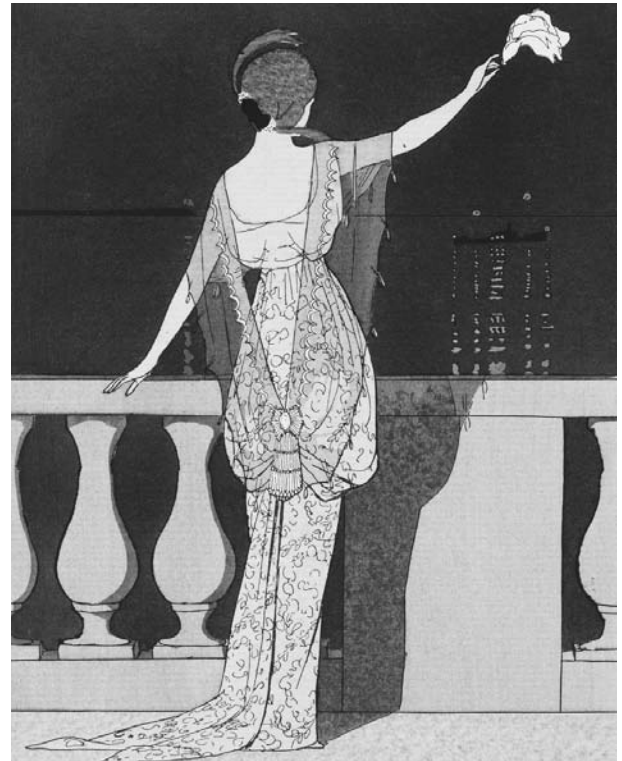

**Illustration of woman wearing Paquin evening dress.** Jeanne Paquin’s imaginative and striking designs, coupled with her savvy business acumen, made her the first female couturier to gain international renown. © STEPLETON COLLECTION/CORBIS. REPRODUCED BY PERMISSION.

followed. Extant examples of these clothes are some of the most stunning works of art in fabric ever created. Signature techniques to achieve these effects, especially in the earlier pieces, included layering, blending, and veiling filmy and textural materials of subtly varying hues; orchestrating the play of light on a garment’s surface by juxtaposing trims and fabrics having differing light-reflective qualities, often outlining them with contrasting piping or chenille; and building up surface design



[Sometimes] ... it is the material that inspires me. But I get inspiration everywhere. When I am travelling or walking in the street, when I see a sunset with beautiful blendings of colour, I often get an inspiration that helps me to evolve new combinations.... Our work in some respects resembles that of the painter.

Jeanne Paquin in *Designs and Publicite*, 1913.





**Woman in a day dress by Jeanne Paquin.** As the fashion capital of the Western world through the eighteenth century, Paris drew wealthy foreigners who came to have their clothes tailor made to copy the latest Paris fashions. COURTESY SPECIAL COLLECTIONS, FASHION INSTITUTE OF TECHNOLOGY. REPRODUCED BY PERMISSION.

motifs with dense encrustations of the smallest possible decorative elements, paying minute attention to size gradation and variation of placement. Endless varieties of gleaming paillettes, beads, and sequins; finely worked shirring and ruching box-pleated ribbon trim; padded appliqué; silk-wound beads; and spotted net were some of the favorite materials used to imbue the gowns with the uniquely Paquin visual quality. Other hallmarks were unorthodox combinations of materials, such as chiffon with serge in a tailored suit and strips of fur on a filmy, pastel evening gown. Always seeking novelty and individualism for her designs, Paquin frequently incorporated elements from other eras and cultures into her contemporary designs, as in a 1912 opera coat fashioned from fabric derived from the eighteenth century and draped like a Roman toga. Her signature accent color was a brilliant pink, and she was famous for her dramatic use of black, both as an accent and as a chic color in its own right. Neoclassicism was a favorite design motif.

While her artistry in visual effects and composition was unsurpassed, Paquin also designed for function and comfort. Through her promotion of these principles, she was a significant force in moving fashion towards the modern style that took hold in the 1920s. She herself frequently wore a practical, ankle-length, blue serge suit for work. By 1905 she was already aggressively promoting the more natural and less restrictive empire line that established the context for Paul Poiret's radical versions of 1908. Between 1912 and 1920 she designed clothes for the active woman, such as a gown that combined tailoring with draping, so that it could appropriately be worn from day into evening, and a version of the hobble skirt that kept the narrow line but allowed for ease of movement with the invention of hidden pleats.

Paquin's contributions in the areas of business, public persona, art, and design firmly establish her place in fashion history as the first great woman couturier.

See also **Fashion Designer; Paris Fashion; Spangles; Worth, Charles Frederick.**

#### BIBLIOGRAPHY

- Buxbaum, Gerda, ed. *Icons of Fashion: The Twentieth Century*. Munich, London, and New York: Prestel Verlag, 1999.
- McAlpin, W. L. "Mme. Paquin Honoured. A Famous Dressmaker and Her Methods." In *Designs and Publicite*. By Jeanne Paquin. Volume 336. Unpublished scrapbook, 1913.
- Reeder, Jan Glier. "The House of Paquin." *Textile and Text* 12 (1990): 10–18.
- . "Historical and Cultural References in Clothes from the House of Paquin." *Textile and Text* 13 (1991): 15–22.
- Sirop, Dominique. *Paquin*. Paris: Adam Biro, 1989.
- Steele, Valerie. *Women of Fashion: Twentieth-Century Designers*. New York: Rizzoli International, 1991.
- Troy, Nancy J. *Couture Culture: A Study in Modern Art and Fashion*. Cambridge, Mass.: The MIT Press, 2003.

*Jan Glier Reeder*

**PARIS FASHION** Paris has been the fashion capital of the Western world from the seventeenth century to the twenty-first century, although other cities, such as New York, London, and Milan, also have become important centers of fashion. The clothes we wear today owe a great deal to Paris, even if they were designed (and almost certainly manufactured) elsewhere in the world.

Prior to the rise of the modern nation-state fashions were geographically dispersed, with loci in Florence and other powerful Italian city-states as well as at the courts of Burgundy and Spain. But France emerged from the end of the Thirty Years' War, in 1648, as by far the largest, richest, and most powerful state in Europe, and the rulers of France—most notably Louis XIV (reigned 1643–1715)—understood that fashion was a potent weapon in establishing France's cultural preeminence. Louis XIV exercised control over his aristocrats by requiring that all who were in attendance at his new court at Versailles be dressed in appropriate fashions. At the

same time the king's chief minister, Jean-Baptiste Colbert, recognized the growing economic importance of textiles and clothing and harnessed the power of the state to France's fashion leadership.

By the eighteenth century, wealthy foreigners were traveling to Paris to have their clothes made, or they employed seamstresses and tailors to copy the latest Paris fashions (which were described in the newspapers of the day), exclaiming all the while at how quickly the fashions changed, how expensive everything was, and how outré the fashions had become. These intertwined themes—eagerness to follow the latest Paris fashions, and outrage over their extravagance, expense, and immorality—were to characterize foreigners' attitudes toward Paris fashion for centuries. Meanwhile, the high-quality tailoring of London (where men's dress was increasingly based on country and sporting clothing, rather than on "Frenchified" court fashions) began to make its influence felt on the continent, and men of fashion throughout the Western world began to dress in English style.

The leadership of Paris in women's fashions accelerated during the nineteenth century, with the rise of what became known as the haute couture. It was not merely that the arts of fine sewing, cutting, and the myriad other techniques necessary for the production of fine garments flourished in Paris. The structure of the industry also evolved, as dressmaking moved from being a small-scale craft to a big business. Prior to the middle of the nineteenth century there were no fashion designers, as such. Dressmakers, assisted by specialized skilled workers, collaborated with their clients to produce garments in the latest styles (which were widely publicized in the burgeoning fashion press). The first true couturier was the Englishman Charles Frederick Worth, a dynamic and enterprising man whose skills at clothing design and dressmaking were matched by his skills for merchandising and self-promotion. He portrayed himself as an artist and an arbiter of taste, whose function was to understand what his clients should wear and to dress them accordingly—a far cry from the old system under which dressmakers basically executed their customers' orders. Meanwhile, the new Paris of grand boulevards shone even more brightly as the setting for fashionable display.

Worth was the first of many designers who took Paris fashion in the direction of the haute couture, the pinnacle of custom dressmaking. But fashion also evolved simultaneously toward the production of *confection*, ready-made dresses, and other garments made for sale in the innovative department stores where items were attractively displayed and clearly marked with fixed prices. In these stores, shopping became a form of recreation that made affordable versions of fashionable dress available to a broad segment of the city's population. By the late nineteenth century, the garment industry, embracing both couture and *confection*, and including ancillary activities such as distribution, merchandising, journalism, and illustration, was one of Paris's most important industries,



**Paquin day dress, 1903.** Jeanne Paquin established a successful couture business that enjoyed unparalleled influence during the first half of the twentieth century. COLLECTION OF VALERIE STEELE. PHOTOGRAPH BY JOHN S. MAJOR. REPRODUCED BY PERMISSION.

employing tens of thousands of workers and making a major contribution to the French national economy. This was recognized in French government backing for efforts to publicize Paris fashions in world markets; for example, fashion was prominently featured in numerous international exhibitions held in Paris.

Paul Poiret was the most influential fashion designer of the early twentieth century, to be followed in the 1920s by Gabrielle (Coco) Chanel, whose dresses redefined elegance as understatement. Chanel had many competitors, however, including Madeleine Vionnet, Jeanne Lanvin, and Elsa Schiaparelli. In the years between the two wars designers (mostly women) created styles that were feminine and body-conscious, and imitated all over the world.

New techniques contributed to the rapid dissemination of Paris fashions throughout the world. Whereas in the nineteenth century clients were shown sample dresses and fitted for their own garments in the privacy of couturier's showrooms, by the early twentieth century the fashion show, with its now-familiar parade of models

wearing the season's new outfits, had become the standard means by which designers introduced their new collections. News of the latest fashions was quickly relayed to magazines and newspapers abroad, and copyists worked overtime to sketch the new designs for production in less expensive ready-to-wear versions. Fashion photography, which by the end of the 1930s had decisively displaced fashion illustration as the preferred means of representing fashion in editorial and advertising copy, also gave rapid publicity to new designs.

World War II and the German occupation of Paris dealt a severe blow to Paris's fashion leadership. Many couture houses shut down for the duration of the war. Those that remained in business found both materials and customers in short supply. Even worse, the vital American market threatened to go its own way, as sportswear designers such as Claire McCardell made a virtue of "the American Look" during this hiatus in Parisian fashion leadership. With the end of the war, the reestablishment of the fashion industry was one of the top priorities of the new French government. With Christian Dior and the creation of the New Look in 1947, Paris found its champion of reasserted fashion leadership.

Dior and his contemporaries, such as Jacques Fath and Hubert de Givenchy, represented a new development in the fashion business. Unlike many of the women designers of the between-the-wars years, whose companies were often very small, these male designers (and a few women, most notably Chanel) were at the helm of large, well-funded corporations, equipped to compete in a new climate of international trade and finance. In addition to their couture collections, they also licensed their names to American manufacturers who produced less expensive lines and ancillary products.

The new reign of Paris did not last long, however. In the early 1960s the "Youthquake" fashions of Carnaby Street turned all eyes on London. Self-taught English designers such as Mary Quant popularized the miniskirt and other "mod" styles. Since the French lacked a youth culture comparable to that of England and America, French couturiers, such as André Courrèges, had to develop a stylistic equivalent. At first, the future served as a metaphor for youth, in the space-age styles of Courrèges and Pierre Cardin. Ultimately, however, the most successful designer to emerge in Paris was the young Yves Saint Laurent, who had formerly worked for Dior.

Saint Laurent was attuned to influences coming from "the street" and from popular culture. Over the next decade, he introduced a number of radical styles, including trouser suits for women, pop-art dresses, safari jackets, pea coats, and other styles derived from vernacular clothing, and, perhaps most importantly, ethnic styles, which drew on the antifashion sensibility of the hippies. Saint Laurent also recognized that many of the women who most appreciated his clothes were too young (and not rich enough) to buy couture, so he also launched a

ready-to-wear line called Rive Gauche (Left Bank). At the same time, however, he reinvigorated the French couture at a time when it seemed to many to be increasingly irrelevant. The 1970s also witnessed the flourishing of Paris *Vogue*, which published controversial fashion photographs by Guy Bourdin and Helmut Newton.

Nevertheless, both New York and Milan became increasingly important centers of fashion during the 1970s. French fashion was regarded as creative and prestigious, but many international consumers preferred the luxurious sportswear created by Italian designers such as Giorgio Armani and the minimalist styles associated with Americans such as Halston. Meanwhile, new subcultural styles—notably punk—developed in London, where Vivienne Westwood dressed bands like the Sex Pistols in deliberately aggressive styles. Paris began to seem a little old-fashioned.

Yet Paris came to the forefront again in the 1980s and 1990s, both because of the revival of famous French brands, and because designers from around the world chose to show their collections in Paris. The house of Chanel, which had been in the doldrums even before Chanel herself died in 1971, became fashionable again in 1983, when the owners hired the German-born designer Karl Lagerfeld. Lagerfeld irreverently revised Chanel's iconic images, exaggerating details and introducing new materials, such as denim and chiffon, to a house long associated with proper tweed suits. Simultaneously, Paris witnessed the invasion of avant-garde Japanese designers such as Yohji Yamamoto and Rei Kawakubo of Comme des Garçons, who launched a radically new style, featuring oversized, asymmetrical, black garments, which were enthusiastically adopted by an influential minority of men and women, mostly associated with the arts. Christian Lacroix launched a new couture house in 1987, showing pouf skirts inspired by Westwood's mini-crisis.

Similarly, in the 1990s, houses such as Dior and Givenchy imported designers from London. John Galiano almost single-handedly transformed Dior with his wild yet commercially successful styles. Alexander McQueen, on the other hand, left Givenchy to establish his own company (backed by Gucci). Significantly, however, McQueen almost always chose to show his collections in Paris, because the Paris fashion shows attracted more journalists than the shows in New York or London. After Saint Laurent retired, the American Tom Ford briefly took artistic control at the famous French house, while also maintaining control at the Italian fashion company Gucci. A host of Belgian designers also showed in Paris, and even many Italian designers, such as Versace and Valentino, moved back and forth between Milan (or Rome) and Paris. As fashion becomes ever more international, the Paris shows now include increasing numbers of designers from countries as diverse as Brazil and Korea.

The globalization of textile and garment manufacturing is changing the economics of the entire fashion system, but the couture, which really exists only in Paris,



retains its prestige and helps to drive an array of luxury goods from perfume to handbags and ready-to-wear lines. Continuing a tradition established many years ago by the Englishman Charles Frederick Worth and the Italian Elsa Schiaparelli, many of the most influential designers in Paris (such as Karl Lagerfeld and John Galliano) are not French. But whatever their country of origin, these designers live and work in Paris. Fashion journalists today have become accustomed to making an exhausting round of fashion shows in New York, Milan, Paris, and London. Even though another city might become paramount during some seasons, Paris remains generally acknowledged as the most important fashion city.

See also **Haute Couture; Italian Fashion; London Fashion; New Look.**

#### BIBLIOGRAPHY

- Milbank, Caroline Rennolds. *Couture: The Great Designers*. New York: Stewart, Tabori, and Chang, 1985.
- Steele, Valerie. *Paris Fashion: A Cultural History*. 2nd ed. Oxford: Berg, 1998.

*Valerie Steele and John S. Major*

**PARKA** A parka is a loose-fitting hooded piece of outerwear invented in prehistoric times by the Inuit people living near the Arctic Circle. Traditionally, and most commonly, made from caribou and sealskins, parkas are also known to have been made from polar-bear fur, bird skins, fox fur, and salmon skins. Today, parkas worn in the non-Inuit world are usually made of nylon, polyester/cotton blended fabric, cotton, or wool, and given a water-repellent coating. The parka has become an item of fashionable winter wear.

#### History

Although the design is of Inuit invention, the word *parka* is of Russian derivation, meaning “reindeer fur coat.” With the Inuit people of Canada’s Arctic region living in some of the planet’s most extreme climates, the parka, like many pieces of outerwear, was originally designed to provide warmth for its wearer. Often two parkas would be worn together (one with the fur facing outward, the other, fur inward) to allow for better insulation and air circulation even in the coldest of temperatures. But although several layers may be worn, the parka remains a fully functional garment, as Betty Kobayashi Issenman explains in *Sinews of Survival*:

The cut and tailoring of Inuit costume create garments that are loose yet fitted when necessary and that admirably meet the requirements of hunter and mother. Hood construction with its close fit and drawstring, ensures clear peripheral vision. Capacious shoulders allow the wearer to carry out complex tasks (p. 40).

It was this ease of movement and the ability to withstand subzero temperatures that led the U.S. army to adopt and adapt the Inuit-styled parka to suit its own needs during World War II.

The prototype field cotton parka was a long skirted, hooded jacket that formed the windproof outer shell for severe conditions. The field parka . . . was standardised after shortening to raise the lower closure to waist level. The longer version was modified by adding fur trimming to the hood (p. 188).

The later nylon-cotton mix M1951, available in olive and white colors, was developed to include a removable mo-hair liner, snap-fastened fly front, adjustable cuffs, and split lower-back sections, and was filled with quilted nylon.

In the mid-1960s, benefiting from fabric developments initiated by the U.S. Army, the nylon parka, worn with tapered stretch pants, became a fashion staple on European ski slopes. Parkas with reversible quilting, corduroy, leather trims, and leather shoulders were all available in a multitude of colors and patterns. Some skiers went for the longer parka while many preferred the shorter version as it was more versatile on the slope as well as for après ski.

During the early to mid-1960s, some of the pioneers in the mod subculture adopted the original army parkas as protection for their much-prized bespoke suits while on their scooters. This helped to move the parka off the ski slopes and into the conventional wardrobe. The parka has remained a winter-fashion constant since the 1960s.

See also **Coat; Inuit and Arctic Dress; Outerwear; Windbreaker.**

#### BIBLIOGRAPHY

- Amies, Hardy. *A, B, C of Men’s Fashion*. London: Cahill and Company Ltd., 1964.
- Byrde, Penelope. *The Male Image: Men’s Fashion in England, 1300–1970*. London: B.T. Batsford, Ltd., 1979.
- Chenoune, Farid. *A History of Men’s Fashion*. Paris: Flammarion, 1993.
- De Marley, Diana. *Fashion for Men: An Illustrated History*. London: B.T. Batsford, Ltd., 1985.
- Issenman, Betty. *Sinews of Survival: The Living Legacy of Inuit Clothing*. Vancouver: University of British Columbia Press, 1997.
- Schoeffler, O.E., and William Gale. *Esquire’s Encyclopedia of 20th Century Fashions*. New York: McGraw-Hill, 1973.
- Stanton, Shelby. *U.S. Army Uniforms of World War II*. Harrisburg, Penn.: Stackpole Books, 1991.

*Tom Greatrex*

**PASHMINA.** See **Cashmere and Pashmina.**

**PATOU, JEAN** Jean Patou (1880–1936) was born in Normandy in northwestern France in 1880. His father was a prosperous tanner who dyed the very finest leathers for bookbinding, and his uncle, with whom he went to work in 1907, sold furs. In 1910 Patou opened a dress-making and fur establishment that foundered, reportedly



**Jean Patou, 1926.** Patou opened his first dressmaking shop in 1910. Though the shop failed, within a few years Patou's designs became popular on both sides of the Atlantic, and he was a leading courtier into the 1930s. © HULTONARCHIVE/GETTY IMAGES. REPRODUCED BY PERMISSION.

due to insufficient funding, although he was able to open a tailoring business in Paris the following year. In 1912 he opened Maison Parry, a small salon located at 4, Rond-Point des Champs-Élysées, which offered dressmaking, tailoring, and furs. Patou's designs were striking for their simplicity in comparison to the prevailing fashions, although his biographer quoted him as stating that this change was the result of ignorance rather than any great fashion instinct. In 1913 a major New York City buyer known as the elder Lichtenstein praised Patou as an innovator and purchased the designer's entire collection, presaging his future popularity in the United States.

### Early Career

In 1914 Patou established a couture house at 7, rue St. Florentin, near the rue de la Paix. Although his first collection was prepared, it was never shown, as he went to serve as a captain in a French Zouave regiment during World War I. Following the cessation of hostilities Patou became a leading international couturier. He commissioned his fellow officer Bernard Boutet de Monvel, who was working for several fashion magazines, to illustrate many of his advertisements. Patou's salon was dec-

orated by the leading art deco designers Louis Süe and André Mare, who painted the interior and upholstered the furniture in a color described as ash-beige, and installed huge mirrors to accentuate the building's elegant eighteenth-century proportions. At the same time that Patou was a shrewd businessman, however, he was also a playboy and a heavy gambler.

Patou did not regard himself as a skilled draftsman; he claimed that not only could he not draw, but also that a pair of scissors was a dangerous weapon in his hands. Each season he provided the designers in his "laboratory" with various antique textiles, fragments of embroidery, and documents annotated with special instructions for the styles and colors he wanted to develop. His staff would then develop these ideas and present him with *toiles* (sample garments made using inexpensive fabric to check cut and fit), which Patou modified until he was satisfied. At the height of Patou's career in the mid-1920s, he made around six hundred models each season, which he refined down to some three hundred. A collection of this size would be considered enormous by contemporary standards, as the *Chambre Syndicale de la Couture Parisienne* specifies that a couture collection must comprise a minimum of only fifty models.

### The Early Twenties

Patou's early 1920s garments, like those of his archrival Chanel, were embellished with colorful folkloric Russian embroidery. His bell-skirted, high-waisted evening dresses, often made in georgette crêpe, were beaded—he particularly liked *diamanté*—delicately embroidered, or embellished with fine lace, which he felt was more youthful than heavy lace. Beige was Patou's primary color for spring–summer 1922, and his collection was received with acclaim. A gown of beige kasha cloth featured a deep V-neckline that was emphasized by a lingerie-style collar, while beige chiffon was combined with kasha to form pleated side panels and full undersleeves that were finished with a tight cuff. Patou was an exceptional colorist, and this season he offered a high-collared evening cape in an unusual shade of beige verging on green; its sole trimming was twisted silk openwork. A beige jersey costume was self-trimmed with bias-cut bands around the collar, cuffs, and hem of the hip-length coat.

Patou and Chanel were the leading exponents of the *garçonne* look that dominated the fashions of the 1920s. Patou was particularly well-known for his geometric designs. Most famous are the sweaters he designed from 1924 with cubist-style blocks of color inspired by the paintings of Braque and Picasso. This ultramodern motif was then applied to matching skirts, bags, and bathing costumes. Although Patou was influenced by the fine arts, he was emphatic that he himself was not an artist, and that a successful couturier did not have to be one. "What is needed is taste, a sense of harmony, and to avoid eccentricity" (Etherington-Smith, p. 38). His eminently wearable sweaters, with horizontal stripes in contrasting

colors teamed with box-pleated skirts, were regularly featured in *Vogue* magazine.

Although Patou was renowned for his smart daywear, his *robes d'intérieur* (negligées) were unashamedly romantic. In 1923 he offered a design in rose-pink satin draped with silk lace dyed to match, and trimmed with clipped brown marabou. British *Vogue* described the gown as shown with “sabot” slippers with upturned toes in white glacé kid, decorated with red leather cutwork and red heels. Another robe was of crystal-embroidered satin worn with Turkish trousers, a “Capuchin hood” and fringed mules of orange and gold brocade. Patou’s shoes were made by Greco (January 1923, p. 45).

**Patou’s sportswear.** Patou’s brother-in-law Raymond Barbas introduced the designer to the world of sport and many of its champions. On meeting the androgynous, smartly elegant tennis star Suzanne Lenglen, Patou recognized instantly that she personified the fashionable “new woman.” In 1921 Lenglen appeared on court at Wimbledon wearing a white pleated silk skirt that skimmed her knees (and flew above them when she ran, revealing her knotted stockings), a sleeveless white sweater based on a man’s cardigan, and a vivid orange headband—she was dressed head to toe by Patou. The audience gasped at Lenglen’s audacity, but the women attending were soon to appropriate similar styles of dress for themselves. Lenglen may have been the first sports champion to endorse the look of a specific fashion designer.

By 1922 Patou had introduced sportswear styles for his fashionable clientele, who wanted to look sporty even if they did not undertake any form of exercise. The same year he introduced his “JP” monogram on his garments; he was the first fashion designer to exploit the cachet of a well-known name. He has also been credited as the originator of the triangular sports scarf worn knotted at one shoulder. In 1924 Patou opened additional branches of his house at the fashionable French seaside resorts of Deauville and Biarritz to sell his ready-made sportswear and accessories. The following year he opened a specialized sportswear boutique called “le coin des sports” within his couture house. This boutique consisted of a suite of rooms, each devoted to a different sport, including aviation, yachting, tennis, golf, riding, and fishing. Patou worked closely with the French textile manufacturers Bianchini-Ferrier and Rodier to develop functional sportswear fabrics.

Patou’s fashions always appealed to the American market, and he brought himself plentiful publicity through his regular contributions to News Enterprise Association (N.E.A.), the nationwide syndication service. To highlight the fact that his designs were as well suited to the “American Diana” as the “Parisian Venus,” the couturier brought six American models to Paris in 1924 (Chase, p. 163). Patou had placed an advertisement in which he advised aspiring applicants that they “must be



**House of Patou, 1955.** This two-piece ensemble worn by a French model is made from chalk white shantung, or orlon-acrylic fiber and silk. Its elegant yet simple lines are typical of early twentieth-century French couturier Jean Patou. © BETTMANN/CORBIS. REPRODUCED BY PERMISSION.

smart, slender, with well-shaped feet and ankles and refined of manner” (Chase, p. 164). Five hundred women responded, of which six were chosen by a committee consisting of society interior decorator Elsie de Wolfe; fashion photographer Edward Steichen; Edna Woolman Chase, the editor of *American Vogue*; *Condé Nast*; and Patou himself. The successful applicants were Josephine Armstrong, Dorothy Raynor, Carolyn Putnam, Edwina Prue, Rosalind Stair, and Lillian Farley. The French couture industry was fiercely nationalist, however, and Patou’s action caused a furor.

**Patou’s perfumes.** Patou developed his first perfumes in collaboration with Raymond Barbas. In 1925 he introduced three fruit-floral fragrances—Amour Amour, Que sais-je?, and Adieu Sagesse—each designed for a different feminine profile. Downstairs in his couture house he installed a cubist-style cocktail bar complete with a “bartender” who mixed special perfumes for his clients. Other fragrances that Patou introduced include Moment Suprême (1929), Le Sien and Cocktail (both 1930), Invitation (1932), Divine Folie (1933), Normandie (1935), and Vacances (1936). The most famous of all, however,



was Joy (1930), which required 10,600 jasmine flowers and 336 roses to make just one ounce of perfume, and which was promoted even during the Great Depression as the costliest fragrance in the world.

### The Later Twenties

For spring–summer 1927 Patou presented knitted sweaters in bois-de-rose wool and jersey with wide and narrow horizontal stripes, and a two-piece costume in palest green whose matching kasha coat was lined in very faint mauve and collared with lynx. All-black and all-white evening dresses were in vogue this season—Patou’s collection included a white gown fashioned from crêpe Roma, with a graceful fluid cut, an uneven hemline, and rhinestone trimming running in diagonal lines across the front. This was also the year he introduced the first suntan oil, called Huile de Chaldée (which was relaunched in 1993).

By winter 1928 Patou was anticipating the silhouettes of the 1930s: his skirts were slightly fuller, there was an impression of length, and his garments were generally more body-conscious. *Vogue* described as “ideal for days on the Riviera” a three-piece ensemble with a coat and skirt with godet of black asperic (a lightweight wool) and a sweater of gray jersey with tiny black diamonds. An evening gown made in a rich caramel-beige crêpe featured a draped bodice that created a higher waistline, while winglike draperies provided extra length.

Edna Woolman Chase recalls an evening in 1929, when after staring across a room at a group of women clad in short dresses and suits designed by Chanel, Patou rushed to his workroom and started feverishly making frocks that swept the ground with natural waistlines. Fashion usually evolved gradually in the 1920s, so when one designer with international influence suddenly presented a new silhouette, it caused a sensation. Patou’s sports costumes were worn four inches below the knee; woolen day dresses worn a little longer, and afternoon dresses a little longer still. His evening gowns—there were several in red with gold lamé—touched the floor on three sides and just skimmed the top of the wearer’s feet at the front. Many items had lingerie details, and Patou’s new color, “dark dahlia” (a red so deep that it was almost black), often replaced black for evening dresses. Other designers immediately followed suit.

### The Thirties

Although Patou was to remain a leading couturier during the 1930s, he was no longer an innovator. A long white evening dress with a print of huge pink and gray flowers for spring–summer 1932, featuring a striking diagonal cut and fabric that trailed over the shoulders and down across the bare back, was perfectly in tune with current fashion trends, but was not instantly identifiable as a Patou model. Where the designer continued to make his mark was in sportswear. He showed a day dress for the same season in thin white woolen crêpe, with a cardigan in navy-blue jersey and a scarf in red, white, and blue

tussore. *Vogue* singled out the ensemble as perfect for summer life in the country, for tennis, boating, and spectator sports. Likewise a navy-blue flannel suit, consisting of a semi-fitted jacket with brass buttons, a straight-cut skirt, and a white crêpe blouse was considered correct for yachting, while looking equally proper on shore. In tune with the fashionable neoclassical styles of the mid-1930s, Patou presented asymmetric evening gowns in white romaine. For fall–winter 1935, dinner suits were important fashion news for semi-formal wear, and Patou offered them stylishly tailored, with one featuring a fantail.

Patou had been renowned for his dramatic openings and first-night parties, but his presentation of his spring–summer collection for 1936 was reported to be strictly businesslike. His new colors were tones situated between violet and pink as well as a clear lime green; several of his evening gowns featured fine shirring and tucking, and his stitched taffeta hoop hats with great bunches of flowers tumbling over one eye.

The 1936 presentation was Patou’s final collection. Later the same year he died suddenly and unexpectedly. Various reasons were given for his death, including apoplexy, exhaustion from work and frenetic gambling, and the after-effects of a car wreck.

### Recent History

Following Patou’s death, Raymond Barbas became chairman of the House of Patou. Barbas had been particularly involved with the designer’s perfumes since the mid-1920s, and the company went on to launch several new perfumes after 1936, including Colony (1938), L’Heure Attendue (1946), and Câlina (1964). Designers for the House of Patou have included Marc Bohan and his assistant, Gérard Pipart (1953–1957); Karl Lagerfeld (1958–1963), Michel Goma and his assistant, Jean-Paul Gaultier (1963–1974); Angelo Tarlazzi (1973–1976); Gonzalés (1977–1981); and Christian Lacroix (1981–1987). The last fashion collection to be offered under the Patou label was shown for fall–winter 1987.

Since then the company has focused upon fragrances, continuing to produce new ones for both the American and European markets, and since 1984 on recreating a dozen of Patou’s original fragrances under the direction of Jean Kerléo at the request of longstanding clients. As of 2004 Jean Patou was run by P&G Prestige Beauté, a division of Procter and Gamble.

See also **Chanel, Gabrielle (Coco); Gaultier, Jean-Paul; Haute Couture; Lacroix, Christian; Lagerfeld, Karl; Paris Fashion; Perfume; Sportswear; Swimwear; Vogue.**

### BIBLIOGRAPHY

Chase, Edna Woolman, and Ilka Chase. *Always in Vogue*. London: Gollancz, 1954. Fashion memoirs of the editor of American *Vogue*. Includes accounts of the competition for editorial space between Chanel and Patou, rival houses that copied Patou’s clothes, and the designer’s recruitment of American models.

Etherington-Smith, Meredith. *Patou*. London: Hutchinson, 1983. Includes biographical details and major design achievements. Illustrated in black and white. Line drawings from *Vogue* magazine and the Patou archive are not attributed or dated.

*Amy de la Haye*

**PATTERNS AND PATTERN MAKING** Clothing production was originally the responsibility of women. After the advent of form-fitting clothing in the thirteenth century, the responsibility expanded to include professional tailors and dressmakers. From the mid-fourteenth century, tailors authored published works on methods for cutting and constructing clothing. “How-To” books for the home dressmaker were published by the late eighteenth century and by the 1830s, small diagrams of pattern shapes appeared in various professional journals and women’s magazines. Full-size patterns as free supplements with fashion periodicals emerged in the 1840s in Germany and France. In the United States, fashion periodicals introduced full-size pattern supplements by 1854. Unlike their European contemporaries, American pattern manufacturers produced patterns for the retail and mail-order market, thereby establishing the commercial pattern industry.

The earliest surviving tailors’ patterns appeared in Juan de Alcega’s *Libro de Geometria pratica y trac a para* (1580). Garasault’s *Descriptions des arts et métiers* (1769), and Diderot’s *L’Encyclopédie Diderot et D’Alembert: arts de l’habillement* (1776), played a crucial role during the Enlightenment to disseminate practical knowledge (Kidwell, p. 4). Intended for the professional tailor, the pattern drafts were the first that were generally available to the public. A number of publications, such as the American *The Tailors’ Instructor* by Queen and Lapsley (1809), and other journals specifically for the professional tailor proliferated in the nineteenth century. These included tailored garments for both sexes.

For the home dressmaker, manuals with full-size patterns and pattern drafts written for charitable ladies sewing for the poor included *Instructions for Cutting out Apparel for the Poor* (1789) and *The Lady’s Economical Assistant* (1808). These featured full-size patterns for caps, baby linen, and men’s shirts. *The Workwoman’s Guide* (1838) contains pattern drafts, drawings of the finished piece, and pattern drafting instructions.

Small pattern diagrams became a popular method of promoting the latest women’s and children’s fashions. Appearing in *Godey’s Lady’s Book* and *Peterson’s Magazine* in the early 1850s, these were unsized with no scale given for enlarging the diagram. Full-scale, foldout patterns were issued as supplements in periodicals as early as 1841 in France and Germany, and in England in *The World of Fashions* (1850).

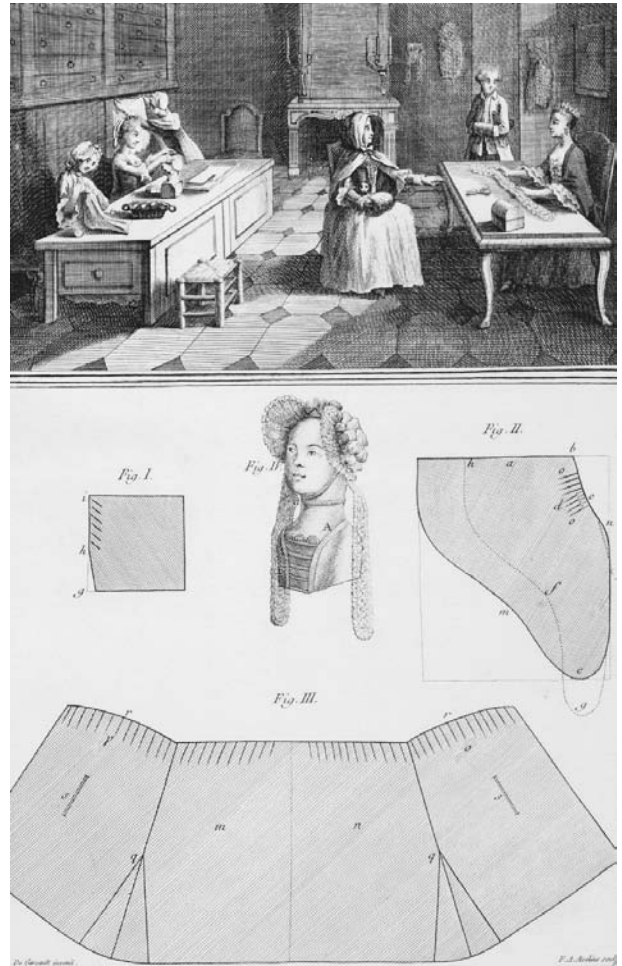

*Dictionary of Sciences*, ca. 1770. This image from the classical eighteenth-century French reference guide illustrates an embroidery workshop along with a contemporary dressmaking pattern. © HISTORICAL PICTURE ARCHIVE/CORBIS. REPRODUCED BY PERMISSION.

### First Generation

In the United States, Godey’s sold full-scale patterns by Mme Demorest through mail order in 1854. *Frank Leslie’s Gazette of Fashions* included full-scale, foldout Demorest patterns in the monthly periodical as well as offering patterns by mail. The patterns were one size only. Because they were offered through retail or mail order, Demorest patterns were the first commercial patterns in the United States (Emery, p. 1999). They offered a wide range of ladies, children’s, and men’s tissue-paper patterns, either plain or trimmed.

Ebenezer Butterick began to make patterns for children’s clothing and men’s shirts in 1863. He expanded the line to include ladies’ garments in 1866 and incorporated Butterick & Company in 1867. A former tailor, he was familiar with graded sizes and offered patterns in a range of sizes from the beginning. The competition expanded in 1873 when James McCall began to manufac-



**A tailor traces a pattern.** Patterns have been used in constructing garments for hundreds of years. The earliest surviving pattern was made in 1580. © ROYALTY-FREE/CORBIS. REPRODUCED BY PERMISSION.

ture McCall's Patterns, offering a range of sizes for all patterns.

Even though varying sizes had a strong appeal, two imports—German and French—were competing for the market. *Harper's Bazaar*, an American version of *Der Bazar* of Berlin, introduced a weekly periodical with a pull-out pattern supplement sheet with 24 or more patterns printed on two sides. The one-size-only patterns are defined by different line codes for each piece superimposed on each other. By 1871, *Harper's* was offering cut-paper patterns, although they continued the overlay pattern sheets until the early 1900s. From France, S. T. Taylor Company imported and marketed full-scale tissue patterns as supplements to each issue of *Le Bon Ton*, beginning in 1868. Taylor also offered made-to-measure patterns.

Two more companies joined the competition in 1873, Domestic and A. Burdette Smith. Domestic was a subsidiary of the Domestic Sewing Machine Company, and their patterns were available in a variety of sizes. Smith's patterns offered a cloth model to facilitate the fitting process.

### Competition and Mergers

The success of the pattern industry encouraged new competitors. In 1887 Frank Keowing, a former Butterick employee, formed Standard Fashion Company and sold Standard Designer patterns through leading department stores. Between 1894 and 1900 several noteworthy pat-

tern companies were formed: New Idea (1894), Royal (1895), Elite (1897), Pictorial Review (1899), and Vogue (1899). Subsequently, these were joined by Ladies' Home Journal (1901), May Manton (1903), and Peerless (1904). Competition was keen, and each company touted the superiority of their patterns and the excellence of fit.

Demorest was the first to go out of business after Mme Demorest, née Ellen Curtis, retired in 1887. Domestic ceased pattern production in 1895; Smith in 1897, *Le Bon Ton* in 1907 and *Harper's* in 1913. Further realignment of the companies occurred through mergers. For example, Butterick acquired Standard Fashion in 1900 and New Idea in 1902, although each retained its identity until 1926. Royal merged with Vogue in 1924.

### The New Generation

Joseph M. Shapiro formed the Simplicity Pattern Company in 1927. Depending on the pattern manufacturer, patterns in 1927 sold for 25¢ to \$1.00. Shapiro's approach was to produce a less expensive pattern. Simplicity patterns sold for 15¢. In 1931 Simplicity formed a partnership with the F. W. Woolworth Company to produce DuBarry patterns, initially selling for 10¢. The company thrived and in 1936 acquired Pictorial Review and Excella, founded in 1922.

Condé Nast, publisher of Vogue patterns, introduced Hollywood patterns for 15¢ in 1932 to appeal to the mass market and the national fascination with the movies. Hollywood patterns ended production in 1947. Advance Pattern Company produced another 15¢ pattern. Established in 1932, evidence suggests Advance was affiliated with J.C. Penney Company (Emery 2001). Advance ceased production in 1964.

Syndicated pattern services such as Famous Features and Reader's Mail flourished in the 1920s. These companies produced inexpensive patterns for sale through newspapers. Mail-order patterns were a popular editorial feature, drawing the homemaker's attention to the paper's advertising pages. Patterns such as *Anne Adams*, *Sue Brunett*, and *Marion Martin* continued to be sold outright to the newspaper as a loss leader. Designs were targeted specifically for families in the middle-income and lower brackets.

### Fashion Periodicals

Patterns were first advertised in existing periodicals such as *Godey's Lady's Book* and *Peterson's Magazine*. In 1860, Demorest introduced its own publication, *The Mirror of Fashion*. It was first offered as a quarterly and later was incorporated in *Demorest's Monthly Magazine*, which established publication practices for subsequent pattern manufactures. The history of U.S. fashion magazines is inextricably linked to the history of the U.S. pattern companies. The advantage of owning and publishing their own periodical was economically sound. Subscriptions were profitable. Extensive portions of the magazines of-



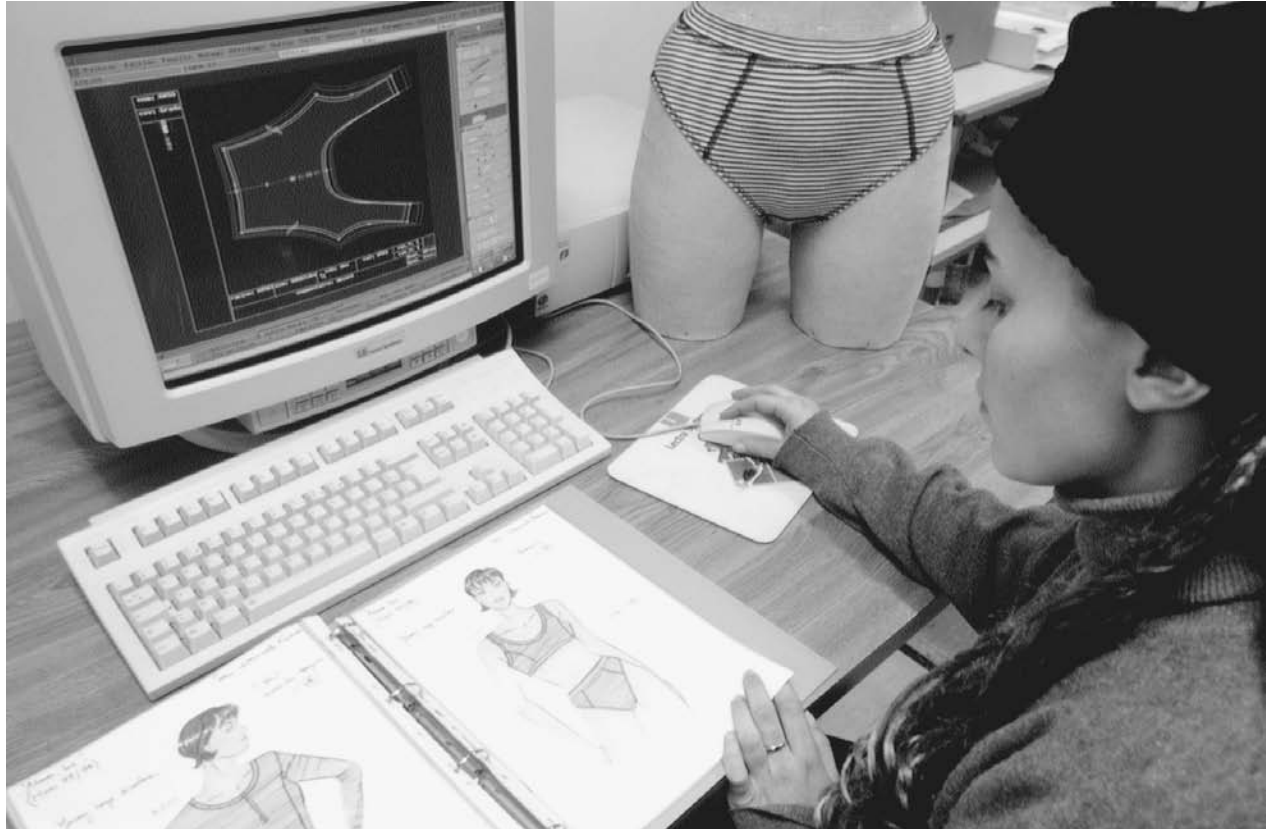

**Computerized pattern-making.** The use of computers in producing patterns has reduced the amount of time for a new pattern to be placed in stores. © ANNEBICQUE BERNARD/CORBIS SYGMA. REPRODUCED BY PERMISSION.

ferred ample coverage of the patterns available as well as articles extolling the virtues of the pattern styles. Further in-house production of give-away flyers and pattern catalogs were cost-efficient.

Such periodicals as Butterick's *Delineator*, McCall's *Queen of Fashion*, and Standard's *Designer* were house organs to promote the patterns with additional editorial features, short stories, and essays on various women's issues. Other established periodicals such as *Ladies' Home Journal* and *Vogue* incorporated sections on their patterns when these lines were established. Pattern companies produced fashion periodicals until the 1930s. These were gradually phased out or purchased by other publishers and the companies concentrated on catalogs to promote their fashions.

#### Technology and Pattern Production

Four key factors supported the development of the pattern industry: the inch tape measure, c. 1820; the availability of the sewing machine by the 1850s; the expansion of the U.S. Postal Service in 1845; and availability of dress forms for the home sewer by the 1860s. These elements were essential components for the proliferation of pattern sales.

#### Making a Pattern

The pattern-making process is virtually unchanged from that developed by Demorest. Once approved, the designer's sketch is drafted to size by the pattern maker in muslin and fitted for an average size—usually size 36 for women. The line and fit of the mock-up is checked before being sent to the grading department for translation to various sizes and transferred to master pattern blocks. The blocks include darts, seams, notches, and other pertinent information. Until McCall introduced the printed pattern in 1921, tissue-paper patterns were made with a series of perforations cut into each piece. The perforation system was partially derived from tailor's markings. The process for making cut and punched patterns remained unchanged and was still practiced by Famous Features Pattern Company until 1996. When McCall's patent for all-printed patterns expired in 1938, other companies converted to printing, although *Vogue* retained perforated patterns until 1956. With the introduction of computerized-design systems, the time for a new pattern to reach the market has been reduced from 2.5 months to as little as four weeks (Chatzky, p. 154).

Early patterns had scant information on how to cut the garment and little instruction on how to make it.

**Table 1: Typical Sizing**

Years	Size 14	Size 18
1920s	Bust 32", Waist 27", Hip 35"	Bust 36", Waist 28", Hip 39"
1940s	Bust 32", Waist 26.5", Hip 35"	Bust 36", Waist 30", Hip 39"
Late 1950s	Bust 34", Waist 26", Hip 36"	Bust 38", Waist 30", Hip 40"
1967 (new sizing)	Bust 36", Waist 27", Hip 38"	Bust 38", Waist 31", Hip 42"
1970s	Bust 36", Waist 28", Hip 38"	Bust 38", Waist 32", Hip 42"
1980s-2000	Bust 36", Waist 28", Hip 38"	Bust 40", Waist 32", Hip 42"

**Sizing Shift.** Pattern companies use similar but not standard sizing systems, the proportions of which have shifted over time.

Initially patterns were folded and pinned together with an attached label to identify the garment and the number of its pieces. Demorest introduced pattern envelopes in 1872. By 1906, pattern layouts were included on the envelopes by many pattern companies. Instructions for making up the garment were introduced by Butterick in 1916. The instruction sheet was called the Deltor, named for the first and last three letters from Butterick's magazine, *The Delineator*. Both the pattern layouts and instruction sheets, which are now standard practice, were done by hand for each pattern style. Today layouts and instruction sheets are done on computer. For the latter, templates such as how to insert a zipper or set in a sleeve, are plugged into the instructions. Most illustrations, which were originally done by hand, are now done on computer, as are the paste-ups for counter catalogs and other promotional materials.

### Fitting Everyone

Proportional systems based on bust or chest measurements combined with height for adults or age (girls and boys) are the foundation for sizing patterns. Developed by tailors, the systems assume that all human bodies are shaped according to common geometric or proportional rules. Thus the patterns are made for an idealized figure. Early pattern diagrams and full-size patterns such as Mme Demorest and Harper's Bazar in the 1850s and 1860s, and Vogue as late as 1905, were not available in a range of sizes. Women's patterns were usually made for an idealized figure of 5' 5" with a 36" bust. Fitting was done by pinning the pattern on the body or form to adjust it to the individual's proportions. Alternatively, the customer could send in detailed measurements to special order a pattern made-to-measure from the pattern company. (Butterick still offers this service.)

Current fashions and undergarments influence proportional systems. As explained in Butterick's *The Metropolitan* in 1871, a lady with a bust measure of 32" usually has a waist of 24", or 8" less than the bust; but a girl of 10 years usually has a bust measure of 27", with the waist usually 24". By 1905 when the flat-front corset was in vogue, the proportion for the 32" bust changed to a 22" waist.

Each company uses its own proportional system; they are similar but not standardized. By the 1920s, sizes

for misses generally dropped the age reference and kept the sizes. Data compiled from the Commercial Pattern Archive digital database (CoPA) illustrate the shifts in typical sizing for size 14 and 18 from the 1920s through 2000 (see Table 1).

Each company continues to offer a wide range of sizes including misses, women's, half-size, petite, junior petite, maternity, toddler, girl/boy, child, men, and infant. Teenage fashions were introduced by Simplicity in the 1940s. In the 1980s Butterick instituted letter-coded sizes called *Today's Fit*, which are designed for the changing proportions of today's figure of about 5'5" with slightly larger waist and hips than misses' sizes. A full range of current size charts can be found in the catalogs and the Web sites of the pattern companies.

### Realignment: 1960–2003

Four major companies currently produce patterns. Butterick acquired Vogue in 1961 producing patterns under both signatures. McCall acquired Butterick and Vogue in 2001 but is producing patterns under all three imprimaturs. Simplicity joined Conso Products Company in 1998.

Diversity is a major incentive. The companies have developed global markets, producing patterns in multiple languages. African American models were included in promotional materials in the 1960s. The style lines have been expanded to include more emphasis on crafts, patterns for period costumes, children's costumes, and vintage reproductions of previous eras.

Patterns are a valuable historical reference for everyday clothing, American ingenuity, entrepreneurship, and the democratization of fashion.

See also **Godey's Lady's Book; Sewing Machine; Tailoring.**

### BIBLIOGRAPHY

- Alcega, Juan de. *Tailor's Pattern Book, 1589*. Translated by Jean Pain and Cecilia Bainton. Bedford, U.K.: Ruth Bean, 1979.
- Arnold, Janet. *Patterns of Fashion: 1560–1620*. London: Macmillan Publishing Company, 1985. One of three in the *Patterns of Fashion* series. Introductions in each contains an excellent overview of clothing production.
- Burman, Barbara, ed. *The Culture of Sewing: Gender, Consumption and Home Dressmaking*. Oxford: Berg, 1999. Excellent

- series of essays covering a breadth of topics related to clothing production.
- Chatzky, Jean Sherman. "Reaping from Sewing." *Forbes* 25 (May 1992): 154–158. Informative article for the pattern business in the early 1990s.
- Emery, Joy S. "Development of the American Commercial Pattern Industry, 1850–1880." *Costume* 31 (1997): 78–91.
- . "Dress like a Star: Hollywood and the Pattern Industry." *Dress* 28 (2001): 92–99.
- Kidwell, C. B. *Cutting a Fashionable Fit: Dressmakers Drafting Systems in the United States*. Washington D.C.: Smithsonian Institution Press, 1979. Concise introduction on the origins of clothing production.
- Mott, Frank L. *A History of the American Magazines*. 5 vols. Cambridge: Harvard University Press, 1938–1968. Thorough coverage of fashion periodicals, especially volumes 3–5.
- Ross, Ishbel. *Crusades and Crinolines: The Life and Times of Ellen Curtis Demorest and William Jennings Demorest*. New York: Harper and Row, 1963. The only full-length bibliography on Mme. Demorest.
- Seligman, Kevin L. *Cutting for All!: The Sartorial Arts, Related Crafts and the Commercial Paper Pattern*. Carbondale, Ill.: Southern University Press, 1996. A comprehensive bibliographical reference related to clothing production.

*Joy Spanabel Emery*

**PENIS SHEATH** A penis sheath is a supplement to the male body enclosing the glans and penis, leaving the scrotum uncovered. Sometimes the term "phallocrypt" is used as a synonym, but Peter Ucko observes that "phallocrypt" refers to dress supplements that cover both the penis and scrotum, whereas the penis sheath conforms and is attached to the penis only. Archeological evidence suggests the practice of applying a penis sheath dates to the prehistoric Near East, Minoan Crete, archaic Greece, and Roman Italy. In the early 2000s, people living in small-scale tribal societies all around the world, including Africa, the Pacific Islands, North and South America, and the Himalayas, still used penis sheaths. Isolated examples have been documented in Japan and among the Inuit and Eskimo American Indians.

Penis sheaths are constructed of a wide variety of materials, including gourds, leaves, grass, raffia, bamboo, netting, basketry, shell, cocoons, ivory, horn, metal, leather, tapa cloth, and woven cotton trade cloth, depending on the culture. The sheath is attached to the body in a variety of ways depending on the style of sheath. The sheath can be shaped to cover and adhere to the penis; it can be attached directly to the glans; or it can be fastened to the end of the foreskin. Sometimes a cord or cloth wrap is used to hold the penis sheath on or at a particular angle. The sheath might be carved, painted, and/or tasseled. It can be as small as five or six centimeters or extend up to the ear of the wearer. The sheaths are not time consuming to make. Even a carved bamboo sheath will require only thirty to forty minutes to complete. The sheath is

part of a whole ensemble of dress that can range from body painting and bead necklaces to shirt and trousers.

The function of the penis sheath in any society is the subject of some debate among scholars and requires more research. What tribal men report and what ethnographers interpret can differ. However, some anthropologically sound functions of the penis sheath can be identified, such as it acting as a carrying pouch, protection, display, or a marker of age, status, or tribal identity.

Informants report that the sheath protects their genitals from the natural environment, particularly bugs and insects when sitting on the ground. Since some sheaths are open at the end, do not cover the scrotum, and are not worn by all groups in the same geographic area, physical protection is not the only function. The penis sheath and its wrappings can serve as a place to store dry tinder and tobacco. Sheaths also act as spiritual protection from evil influences that can enter body orifices, particularly through the genitals. Some scholars suggest the penis sheath functioned as a threat or dominance display in battle. As threat displays became more symbolic than practical, some societies have developed penis sheaths for different occasions, from ceremonial use to everyday wear.

In the early days of anthropology, modesty was considered a function of the sheath. This idea has fallen to the wayside because human groups vary in their ideas of what is "naked" and "shameful." For many men, wearing the penis sheath is part of their definition of being dressed appropriately for interaction with others. A comparable example is the codpiece, which was fashionable in the sixteenth century, and part of the well-dressed European man's ensemble. In any case, one can see by looking at various examples of the penis sheath that it both conceals the penis and draws attention to the genital region. The codpiece and the twenty-first century men's Speedo or thong swimming-suit function the same way. The act of revealing while concealing appears to be a panhuman use of dress in general.

The age when a boy begins wearing a penis sheath varies from society to society. In some cultures, when the boy has his first semen emission, there is a ritual donning of his first sheath. In other cultures, the first sheathing is part of the process of coming of age from youth to adult. Throughout life, a change in style of sheath may mark achieved status from child to warrior to husband to elder. For example, in A. F. Gell's study of penis sheathing in a West Sepik village spanning the border of New Guinea and West Irian, there were both secular and ritual penis sheaths called *pedas* used across the lifespan, and the pattern of their use is cyclic in opposition to each other. Peter J. Ucko points out that in some groups the youth wear penis sheaths at a time in their lives when virility is alluring and the elders are freed from the responsibility of this signal. By contrast, in other groups the older men wear penis sheaths and the young do not,



denoting changing times. Often, the morphology of the penis sheath will differ from place to place, so the individual can be visually identified as a member of one group or another. In Gell's study, we can see that in one part of the valley, egg-shaped penis sheaths were used in the north and elongated sheaths in the south.

Even though different groups may have a general style of penis sheath unique to them, there may be little standardization within the group, allowing the individual the opportunity for aesthetic expression. Similarly, absence of a penis sheath communicates state of mind. For some groups, not wearing a penis sheath means the man is an adulterer (implying one function of the penis sheath as contraception by inconvenience), feeble minded, or in mourning and temporarily withdrawing from social life.

With a handful of exceptions, the penis sheath is exclusively a masculine symbol. It is more than a covering or a display. It is a unique form of material culture that draws one in to an understanding of the physical, social, and aesthetic life of people.

See also **Cache-Sexe**; **Codpiece**.

#### BIBLIOGRAPHY

- Gell, A. F. "Penis Sheathing and Ritual Status in a West Sepik Village." *Man* 6, no. 2 (June 1971): 165–181.
- Heiser, Charles B., Jr. "The Penis Gourd of New Guinea." *Annals of the Association of American Geographers* 63, no. 3 (September 1973): 312–318.
- Ucko, Peter J. "Penis Sheaths: A Comparative Study." *Proceedings of the Royal Anthropological Institute of Great Britain and Ireland* (1970): 24A–67.
- Wickler, W. "Ursprung und biologische Deutung des Genitalpräsentierens männlicher Primaten." *Z Tierpsychol* 23: 422–437.

Sandra Lee Evenson

**PENN, IRVING** Irving Penn, who was born in 1917 in Plainfield, New Jersey, is considered one of the great American photographers of the mid-twentieth century, not solely one of its masters of fashion photography, in which he initially made his name. His reputation might equally have been secured by a command of portraiture and austere still life. In a career spanning six decades, he has had success too with botanical studies, the beauty photograph (most markedly for advertising purposes), ethnographical documents of cultural types, studies of voluptuous nudes, and with his book *Dancer* (2001), meditations on movement and the body. He disallows any of these disciplines from taking precedence in his oeuvre, but his name is inescapably synonymous with fashion photography. Since 1943 Penn's photographs have appeared regularly in *Vogue*, where his career was nurtured by Alexander Liberman, the magazine's art director from 1943 to 1962.

#### Beginnings at *Vogue*

Penn studied at the Philadelphia Museum School of Industrial Art (1934–1938). Alexey Brodovitch, art director of *Harper's Bazaar*, whose design seminars Penn attended, introduced him to fashion magazines; moreover, he hired Penn to be his assistant during two summers. Brodovitch published some of Penn's illustrations in 1937. In the same year, Penn undertook a series of street photographs of the shop signs and facades of New York, where he was laying the groundwork for a career in the fashion world by working as a freelance graphic designer and consultant art director for Saks Fifth Avenue.

By 1942, having spent a year painting in Mexico, Penn recognized that his future lay elsewhere. In 1943 Liberman hired him as a creative assistant in the art department of *Vogue*. Penn found *Vogue's* photographers mostly ambivalent about his ideas for the magazine's cover artwork and instead put them into practice himself. His first *Vogue* cover, a still life composition of accessories, was published in October 1943. Over the next sixty years he photographed nearly 170 more. Shortly after his 1943 debut, he embarked on the photography of clothes. He followed this with a short-lived but inventive series, *Portraits with Symbols*, a stylish fusion of still life and portraiture in which well-known figures posed with objects that evoked aspects of their personalities.

#### Portraits

Between 1944 and 1950 Penn completed more than three hundred portrait sittings for *Vogue*, the subjects for which ranged from the Spanish artist Salvador Dalí to Senator Hubert Humphrey. He rarely photographed outside the formal confines of the studio during this period and approached these sessions as he did his still life studies that punctuated *Vogue's* pages at this time: his models faced the lens in carefully arranged poses against the simplest of studio backdrops, where nothing was left to chance. His intention was to eschew artifice and flattery in favor of a timeless clarity. His celebrated "corner portraits" date from this period (1948–1949), too. Placing two studio flats at an acute angle to create a confining space for his sitters, Penn recalled that "the walls were a surface to lean on or push against. . . . [L]imiting the subjects' movement seemed to relieve me of part of the problem of holding on to them" (Penn, 1991, p. 50).

#### Apogee at *Vogue*

Penn's *Vogue* fashion photography reached its apogee with his coverage of the Paris collections of 1950. Stripped bare of props and artifice, the results appeared monumental in their simplicity, in the light of which the tableaux of Horst, Cecil Beaton, and Erwin Blumenfeld, his contemporaries in the pages of *Vogue*, suddenly seemed as overdressed as stage sets. Penn's uncluttered compositions against seamless gray paper, as taut and as concentrated as his portraits, remain unsurpassed as documents of haute couture at its zenith. For many of these

fashion photographs he collaborated with the model Lisa Fonssagrives (1911–1992), whom he married shortly after their completion. His most famous cover for *Vogue*, a monochromatic study of the model Jean Patchett in fashion by Larry Aldrich, dates from 1950 and marks the first occasion *Vogue* ran a black-and-white photographic cover.

### Ethnographic Photography

Besides his important work for *Vogue* at mid-twentieth-century, Penn began pointing his camera in new directions. In 1949, while on a fashion story for *Vogue* in Peru, he found a nineteenth-century daylight studio in the town of Cuzco. There, over three days, he photographed the town's residents (wearing their exotic clothing) and visitors against a painted cloth backdrop, thereby initiating a regular series of portraits documenting different cultures. This pursuit led him far afield in later years, to such locales as Dahomey, Nepal, Cameroon, New Guinea, and Morocco. He brought the same spirit of wonderment to chronicling these exotic dresses as he brought to his photographs of ethnic types and his celebrated series of tradespeople in Paris, London, and New York, which he also initiated in 1950.

### New Directions

Penn embarked on his nude studies in 1949, continuing to work on them intermittently between *Vogue* fashion assignments, to which they stand in stark contrast. His subjects were in his own words "soft and fleshy, some very heavy." But he required the same of them as he did his fashion models: it was "more important [that] they were comfortable with their bodies" (Penn, 1991, p. 66). *Vogue* commissions and other commercial work, mostly advertising, occupied Penn for the remainder of the 1950s. In 1960 he published his first book, *Moments Preserved*, which contained the best of his fashion photography of the previous decade. The following year, in tandem with his *Vogue* duties, he began a series of annual photographic essays for *Look* magazine (1961–1967).

In 1964 Penn began to experiment with printing in precious metals, most notably platinum, palladium, and iridium. He continued refining these processes for exhibition pieces, which have included fashion masterworks such as *Lisa in Harlequin Dress* by Jerry Parnis (1950) and *Sunny Harnett in Ben Reig Silk-Chiffon Blouse* (1951). Penn became increasingly disenchanted with fashion photography in the 1960s and from then on his photographs in *Vogue's* fashion pages became something of a rarity. "Nowadays," he told one commentator, "all that is required is a banal photograph of a girl in a dress." From the mid-1970s Penn regarded original work for exhibitions and books as more creatively fulfilling than editorial commissions. However, his beauty and still life compositions, and occasionally fashion pictures, continue to be published by *Vogue* almost on a monthly basis; thus, with more than sixty years contributing to the magazine,

he is its longest-serving photographer. With an undeniable imprimatur on *Vogue*, he is one of the most influential fashion photographers of the twentieth century.

See also **Beaton, Cecil; Fashion Photography; Horst, Horst P.; Vogue.**

### BIBLIOGRAPHY

- Fielden, Jay, ed. *Grace: Thirty Years of Fashion at Vogue*. Paris: Edition 7L, 2002.
- Fraser, Kennedy. *On the Edge: Images from 100 Years of Vogue*. New York: Random House, 1992.
- Hall-Duncan, Nancy. *The History of Fashion Photography*. New York: Alpine Books, 1979.
- Hambourg, Maria Morris. *Earthly Bodies: Irving Penn's Nudes, 1949–1950*. Boston: Little, Brown, 2002.
- Harrison, Martin. *Appearances: Fashion Photography since 1945*. New York: Rizzoli, 1991.
- . *Lisa Fonssagrives: Three Decades of Classic Fashion Photography*. New York: St. Martin's Press, 1996.
- Howell, Georgina. *In Vogue: Six Decades of Fashion*. London: Allen Lane, 1975.
- Kazanjian, Dodie, and Calvin Tomkins. *Alex: The Life of Alexander Liberman*. New York: Alfred A. Knopf, 1993.
- Liberman, Alexander. *The Art and Technique of Color Photography*. New York: Simon and Schuster, 1951.
- Penn, Irving. *Moments Preserved: Eight Essays in Photographs and Words*. New York: Simon and Schuster, 1960.
- . *Worlds in a Small Room*. New York: Grossman, 1974.
- . *Inventive Paris Clothes 1909–1939: A Photographic Essay*. New York: Viking, 1977.
- . *Irving Penn: Photographs in Platinum Metals: Images 1947–1975*. New York: Marlborough Gallery, 1977. An exhibition catalog.
- . *Flowers: Photographs*. New York: Harmony Books, 1980.
- . *Recent Still Life: Negatives 1979–1980, Prints in Platinum Metals 1980–1982*. New York: Marlborough Gallery, 1982. An exhibition catalog.
- . *Issei Miyake*. New York: New York Graphic Society, 1988.
- . *Passage: A Work Record*. New York: Alfred A. Knopf, 1991.
- . *Irving Penn Photographs: A Donation in Memory of Lisa Fonssagrives-Penn*. Stockholm: Moderna Museet, 1995.
- . *Irving Penn Regards the Work of Issey Miyake: Photographs 1975–1988*. London: Jonathan Cape, 1999.
- . *Irving Penn*. New York: Pace/MacGill Gallery, 1999.
- . *Drawings*. New York: Apparition, 1999.
- . *The Astronomers Plan a Voyage to Earth*. New York: Apparition, 1999.
- . *Irving Penn: Objects for the Printed Page*. Essen, Germany: Museum Folkwang, 2001.
- . *Dancer*. Tucson, Ariz.: Nazraeli Press, 2001.
- . *Still Life: Photographs 1938–2000*. New York: Bulfinch Press, 2001.
- Szarkowski, John. *Irving Penn*. New York: The Museum of Modern Art, 1984.

Westerbeck, Colin, ed. *Irving Penn: A Career in Photography*. Boston: The Art Institute of Chicago in association with Bulfinch Press/Little, Brown, 1997.

*Robert Muir*

**PERFORMANCE FINISHES** Performance, or functional, finishes are treatments that are applied to woven, knitted, or other textiles to modify their chemical or physical properties. Fabrics can be made to resist shrinking, fading, wrinkling, and soiling. Antimicrobial, antistatic, and water-repellent properties can be added and fabrics can be made more resistant to burning. Most fabrics (or in some cases garments) are treated after dyeing or printing, so that the finish will not interfere with the application of color.

### Shrinkage Control

A textile property of significant consumer interest is the ability of fabrics to maintain their dimensions, whether the textile is used in apparel or home furnishings. Shrinkage is a reduction in fabric length or width; growth is a term used for an increase in a fabric dimension. A fabric that neither shrinks nor grows is said to be dimensionally stable. When one considers that a garment with a 25-inch waist will decrease by 1¼ inches if it shrinks only 5 percent, it is understandable that controlling shrinkage has been a goal of textile producers and finishers for many years. Such control has usually involved submitting the fabric to conditions such as moisture or heat that might induce shrinkage, before it is sewn into garments.

Fabrics most susceptible to shrinking during laundering are those that have high moisture absorbance. These include cotton, rayon, linen, and wool. Most synthetics (polyester, nylon, acrylic, and olefin) do not absorb water to a great extent and have higher dimensional stability. Manufacturing of woven or knitted fabrics imposes stresses in the materials as they are stretched and held taut. When the tension is removed and these fabrics are subjected to wetting during laundering, the yarns relax, moving closer together. The amount of relaxation depends on the degree of stretching the fibers underwent during manufacturing and the propensity of the fibers to absorb water and to stretch. Wool and rayon are more extensible than many other fibers and therefore shrink more. Wool has a further problem in that the fibers are covered with scales that can catch and lock together, entangling under conditions of moisture, mechanical action, and heat. This is called felting shrinkage and is the primary reason wool fabrics are not normally washable. These differences in fabrics and fibers point out not only the specification of laundering or dry-cleaning procedures for textiles, but also the need for development of shrinkage-control treatments that are fiber and fabric specific. Compressive shrinkage, the most general control method, is appropriate for 100-percent cotton, linen, or rayon fabrics. In the process, the fabric is dampened

and placed on a thick woolen or felt blanket that travels around a small roller. The wet fabric is stretched as it moves around the contour of the roller and then compresses and squeezes as it enters a straight area. Heat is applied to set in the compressed structure. Sanforized and Sanfor-set are trade names for this type of shrinkage-control treatment.

Wool fabrics require special treatments to inhibit both relaxation and felting shrinkage. The former can be controlled by dampening or steaming the fabric and allowing it to dry in a relaxed state. In one variant of this, decating, the fabric is wound on a perforated cylinder and steam is injected. Cold air then sets the relaxed fabric structure. Preventing felting shrinkage allows wools to be laundered. These treatments involve altering the scales on the wool fibers so they do not catch on each other and become highly entangled. One such process degrades the outer scale layer, making the fibers smoother. A preferred method, which runs less risk of degrading the fiber itself, is to mask the scales by applying a thin polymer film.

Synthetic fibers, which are sensitive to heat, can shrink when heat is applied. This phenomenon is apparent when synthetic-fiber fabrics are ironed at too high a temperature. The tendency for heat shrinking can be controlled in finishing by heat setting the fabric at a temperature that allows the molecules in the fibers to relax somewhat. They are therefore less likely to relax further and shrink during the use and care of the textile product.

### Wrinkle Resistance

Fabrics made from cotton, rayon, and linen wrinkle easily and will also retain these wrinkles. Cotton and cotton-blend fabrics particularly will often have wrinkle-resistance finishes applied to lessen the need for ironing. These finishes date back to 1929 when cotton fabrics were treated with a chemical compound of urea and formaldehyde to form a polymer resin inside the fiber. The chemical treatment stiffened the fabric, making it "crease resistant."

In the 1950s such treated fabrics, as well as those made from nylon and polyester, which have natural wrinkle resistance, were termed "wash-and-wear." This emphasized that they would not need to be ironed after laundering. Many of these wash-and-wear finishes did, however, require some touch-up ironing.

Further advances in the chemistry of formaldehyde containing finishes produced the permanent-press fabrics of the 1960s and 1970s. Today they are referred to as durable-press finishes in recognition of the fact that the finish is quite durable to laundering but is not permanent. The most frequently used durable-press finish is dimethyloldihydroxyethyleneurea (DMDHEU). The chemical is applied to the fabric and then cured (that is, heated in an oven to react with the cellulose molecules in the cotton or rayon). The reaction bonds the molecules together so that they cannot move around and allow wrinkles to set.



Treated fabrics are cured either before they are fashioned into garments or after. Precured fabrics have their flat shape set in and can be difficult to handle during manufacturing into final textile products. In an alternative postcuring process, the finish is applied to the fabric that is then made into apparel and the curing step occurs subsequently. This allows creases, pleats, hems, and other features to be durably set in the garments.

### Soil and Stain Resistance

Soiling can be inhibited by preventing its deposition on the fabric or by facilitating its removal. The range of finishes that includes the patented Scotchgard are examples of the first category. The most effective ones contain fluoropolymers and work similarly to the finish on stick-resistant cookware in repelling stains and soils. The surface energy of the fluoropolymer finish is so much lower than that of liquids that may spill on the fabric that both water-borne and oily soils bead up and do not penetrate into the fibers. These stain- and soil-resistant finishes also provide a degree of water repellency to the treated fabrics. Another general class of stain-resistant finishes is based on silicones. Silicone finishes resist water-borne stains but do not repel oily liquids.

There are also finishes that aid in removing soils and stains that do become attached to fibers. These agents, generally referred to as soil-release finishes, were developed to address the tendency of polyester and durable-press fabrics to absorb and hold oil-borne stains. Water and detergent were not as readily able to penetrate these fabrics and lift out the stains, as had been the case with unfinished-cotton fabrics. The common mechanism of the variety of soil-release finishes is to make them more attractive to water-based detergent solutions. A secondary benefit of soil-release finishes is that, since they attract water, they reduce build-up of static electricity and therefore also serve as antistatic finishes.

Special fluorochemical finishes that confer both soil resistant and soil-release properties are available. These dual-acting finishes are long-chain polymers that have blocks containing fluorine to repel water, oil, and soil, and blocks that attract water. In air, the fluorochemical blocks come to the surface to resist stains. When the fabric is immersed in water, the other, water-loving, blocks are on the surface, enhancing the ability of the fibers to absorb water.

### Flame Resistance

Providing some form of resistance to burning has been an objective of fabric finishers for centuries. Early finishes were temporary in that they were removed when the fabrics were laundered. Growing concern for safety in this century brought about federal regulations for required flame resistance for fabrics used in clothing. Local and state laws impose regulations on the flammability of textile materials in public buildings. As a result, durable flame-retardant finishes were developed.

In the literature in this area, a distinction is made between the terms “flame resistant” and “flame retardant.” Flame resistant is more general, referring to the resistance of a material to burning. That property can be due to a fiber that is inherently resistant to ignition and/or propagation of flames or can be conferred by application of a finish. In the latter case, the finish is a flame-retardant chemical. Many synthetic fibers shrink from flames and therefore resist ignition. They will burn, however, upon ignition and can be treated to inhibit combustion. Modacrylic is naturally flame-resistant, as are some of the high-performance fibers used today in garments for firefighters and race-car drivers. Cotton and other cellulosic fibers such as rayon and linen will burn readily; they have the same chemical structure as paper. It is these fibers that normally require a retardant finish to make them flame-resistant.

Flame-retardant finishes work either by quenching the flame or by producing char that interferes with the combustion process. Finishes for nylon and polyester contain bromine that reduces the generation of flammable gases. Durable finishes for cotton and cotton-blend fabrics are phosphorus compounds which react chemically with the cellulose fibers and inhibit the production of compounds that fuel the flame.

### Other Finishes

Other possible finishes include antimicrobial, light-resistant, mothproof, and temperature-regulating finishes.

**Antimicrobial finishes.** Clothing, particularly soiled clothing, is susceptible to growth of mold, mildew, and bacteria. Not only does the growth of these microbes on fabric present health problems, it also causes odors. Antimicrobial agents to protect against both can also be incorporated into manufactured fibers before they are spun or can be applied as finishes to fabrics. Antimicrobial finishes work either by setting up a barrier against the microbes, preventing them from attaching to the fibers, or alternatively by killing the offending organisms. Agents that kill fungi and bacteria are divided into two general classes; organic materials and compounds containing metals. Copper, zinc, and silver are biocidal metals that have been used on fabrics and clothing items such as socks and underwear. Ammonium salts and phenols are organic compounds that are applied. The active ingredient in Lysol antiseptic spray is a phenolic compound.

**Light-resistant finishes.** The ultraviolet (UV) rays in light can be harmful to clothing fabrics, as well as to the people wearing them. UV light breaks the polymer chains comprising fibers, ultimately weakening fabrics. Some fibers (cotton, rayon, silk, olefin) are more readily damaged than others. The light can also change the structure of dyes, causing fading of fabrics. Light-resistant finishes work either by preferentially absorbing UV radiation that would be harmful to fibers or dyes, or by reflecting such radiation so that the textile does not absorb it. Concerns

over the harmful effects of UV light on skin have prompted development of finishes that enhance absorption or reflection. Apparel made from fabrics with these finishes is advertised as having UV or sun-protective qualities.

**Mothproofing finishes.** Wool fabrics are damaged by moth larvae, which consume the wool protein, leaving holes in the fabric. Traditionally, wools were stored in bags with mothballs, large pellets containing the ingredient naphthalene that killed the larvae. In the early 2000s, finishes were available for a durable application during fabric manufacturing or a renewable application when wool items are dry-cleaned.

**Temperature-regulating finishes.** Temperature-regulating fabrics are sensitive to the surrounding temperature or to body heat. They are generally referred to as phase changes materials because they change from one phase (solid to liquid or liquid to solid) in reaction to the surrounding temperature. The phase change consumes or releases heat. Polyethylene glycol exhibits this behavior when applied to fabrics. It absorbs and holds heat at high temperatures, cooling the wearer; it then releases this stored heat energy under cooler conditions. The finish has been applied to T-shirts, underwear, socks, and sportswear.

See also **Cotton; Rayon; Wool.**

**BIBLIOGRAPHY**

Mark, H., Norman S. Wooding, and Sheldon M. Atlas. *Chemical Aftertreatment of Textiles*. New York: Wiley-Interscience, 1971.

Slade, Philip E. *Handbook of Fiber Finish Technology*. New York: Marcel Dekker, 1997.

*Billie J. Collier*

**PERFUME** Perfume, from the Latin *per fumum*, meaning through smoke, has been a barometer of society and its mores throughout recorded history. Like fashion, it provides a road map to people’s strivings for individuality, self-aggrandizement, social standing, and feelings of well-being.

Early Egyptians are credited as one of the first groups to improve their lives and deaths through the use of fragrance and fragrance ingredients, particularly blended for burning during religious services and burial. Historical references cite Ishmaelite traders who, in 2000 B.C.E., bore aromatic treasures to eager customers in Egypt via what was known as the Incense Road. Considered more precious than gold, flowers, herbs, and spices, perfumes were an expression of exaltation and admiration. The importance of perfumes gradually reached far beyond Egypt thanks to traders, crusaders, and shifting populations who took their precious fragrances with them. This was a fortuitous turn of events for the future of fragrance.

Perfume ingredients became indispensable in religious services, as medicants, to enhance personal environ-

ments, and to be applied to the skin for protection against the elements. Perfume was also used as an aphrodisiac. The famous and infamous embraced fragrance and made it their own. Cleopatra (60–30 B.C.E.) doused the sails of her ship to entice Mark Antony. The Queen of Sheba won the heart and devotion of King Solomon by bringing him gifts of rare spices all the way from Yemen. He particularly favored the fabled myrrh. It is said that each drop of Muhammad’s sweat, as he ascended to heaven, morphed into the most precious of flowers—the rose.

It was the Egyptians who learned how to press the oils from flowers and leaves that they then smoothed on their sun-scorched skins. The Arabian doctor Avicenna is credited with developing the method of distillation, in the tenth century, which led to the creation of liquid perfume.

Little has changed in the gathering and processing of perfume ingredients. Flowers and plants are picked and gathered by hand, and distillation, in which steam separates the essential oils from the flowers and plants, remains one of the prime methods for extraction. (It is one of six methods: expression, maceration, enflourage, extraction, and headspace technology.) In modern times, the greatest change has taken place in the fragrance laboratories where computer technology has become a basic tool, not only in establishing and maintaining quality standards, but also in allowing perfumers around the world to communicate with each other in developing unique new fragrance formulas.

**Hand in Glove**

Fragrance and fashion were linked for the first time in the thirteenth century. The setting was Grasse, France (located between Nice and Cannes) that at the time was the center of the glove-making industry. The problem these artisans faced, however, was the unbearable smell of the leather that was tanned with urine.

The fragrant flowers of Grasse, the province of the local perfumers, came to the rescue of the tanners and perfumed gloves became the rage throughout fashionable Europe. As a result, industrious glove-makers added the title of perfumer. They enjoyed great success until the early 1800s when they were taxed out of business and as a result moved away, leaving a talented coterie of flower growers and perfumers. Grasse flourished as the perfect source of flowers, especially lavender, jasmine, and tuberose that grew on the sun-drenched hills. In the twenty-first century, Grasse is a shadow of its former self, as real-estate developers usurped much of the land in the latter part of the twentieth century. It no longer is the prime source of flowers, roots, and herbs sought by the modern fragrance industry. The whole world serves the perfumers’ fragrant needs.

**Scents of Royalty**

The desire to adorn the body with sweet smells and beautiful jewelry created a marriage of fashion and fragrance

that reached its heights in the early 1700s, particularly during the reign of Louis XIV. It was then that European royalty decided to have their fragrances at hand night and day no matter where they might be. Aromatic jewelry designed by master craftsmen was in great demand. In fact, royalty had their own private jewelers and perfumers to cater to their every whim. Chatelaines, rings, earrings, belts, and bracelets were considered indispensable. Wealthy men, women, and children all wore decorative aromatic accessories.

### Courting Perfume

In 1533, when Catherine de Medici left Italy to marry Henry II, she took all of her personal perfumes and perfumers with her. It was not uncommon for royalty and wealthy citizens to employ their own perfumers and jewelers who were responsible for creating exquisite one-of-a-kind containers for each perfume. The marriage of Marie Antoinette to the future king of France, Louis XVI, united two intense devotees of perfume. Both reveled in environments heavy with scent. But it was Louis XIV who became known as “The Perfumed King” in the seventeenth and early eighteenth centuries. His retinue of perfumers created different scents for him and his court to wear morning, noon, and night. In his court, the wings of doves were drenched with fragrance to be released after a great banquet to fill the air with refreshing scents. Extravagance was the coin of the realm. Vessels were designed to allow incense to be sprinkled on carpets and in dresser drawers. Incense was also burned to fumigate clothes, living quarters, and to induce sleep.

### Street Scents and Scenes

The growth of the urban environment in the eighteenth century gave meaning to fragrance for the masses. Overcrowding, lack of sanitation, and pollution made life unbearable. Fears of unknown diseases lurking in the water kept people from bathing. Perfumes emerged as the panacea for the great-unwashed populace. Crudely made perfumes and colognes could be bought on the street by roving self-appointed perfumers who hawked their fragrant wares from garments which looked like cook’s aprons. Scent bottles filled the many pockets. The French Revolution put a stop to royalty’s fragrant revelries and perfume didn’t regain its popularity until the early nineteenth century, when Napoleon became emperor. There was no limit to his fragrance indulgences. He virtually bathed in *eau de cologne*, and never went into battle without a full supply of his favorites. His wife, Josephine, loved roses and musk, and she surrounded herself with them night and day. But, when Napoleon left her for Marie Louise, Josephine filled the rooms of Malmaison with the overpowering scent of musk, which she knew Napoleon disliked intensely. Visitors to Versailles report they smell it still.

The twentieth century saw the birth of fashion designer fragrances (primarily of French origin). They were



**Chanel No. 5 advertisement.** Chanel launched its No. 5 perfume in 1921. It was one of the first and most popular of the fashion designer perfumes that dominated the fragrance market of the twentieth century. THE ADVERTISING ARCHIVE LTD. REPRODUCED BY PERMISSION.

referred to as the invisible accessory by merchants and the media, to be worn on special occasions. Then, in 1921, the great couturier, Gabrielle Chanel, set the fashion world on fire when she launched her breakthrough creation, Chanel No. 5. It was the first aldehydic type that is characterized by its rich sparkling quality. It became an overnight sensation and established a new category for the perfume world.

Chanel was not the first designer to sniff the potential of scents, however. Credit must be given to Paul Poiret, whose exotic designs were inspired by the mysteries of the Far East and who achieved recognition and applause for his art deco costumes for theater and ballet. Fascinated by the imaginative and ephemeral, he adored fragrance and became a perfume entrepreneur in the early 1900s. He established his own laboratory and facilities for blowing glass and packaging his “small wonders.” His company, Parfumes Rosine, was named for one of his daughters. Of the more than fifty perfumes (floral, spicy, and oriental types dominated) introduced between 1911 and 1924, several carried his daughter’s name. La Rose de Rosine was presented to the public in the mid-twenties as was La Chemise de Rosine and Mon Choix de Rosine. In 1927, inspired by the flight of Charles Lindbergh, Poiret



launched Spirit of St. Louis, which was one of his last fragrance creations.

Poiret's couture clients, artists, actresses, and the wealthy, in the U.S. and abroad, quickly became his fragrance customers as he encouraged them to consider fragrance one of his most important fashion accessories. They responded enthusiastically. After World War I, however, his fashion house floundered. His fragrances continued to enjoy popularity in the United States where they were re-introduced. Poiret closed his business in 1930.

### Designers and Grand Dames

The fascination with fragrance did not lose its momentum thanks to Chanel and an unending parade of designers who became arbiters of styles in scents with innovations of their own: Worth (*Dans La Nuit*, 1922), Jeanne Lanvin (*My Sin*, 1925). The legendary Arpege wasn't introduced until 1927. What was described as the most expensive perfume in the world, *Joy*, was launched by Jean Patou in 1930. Elsa Schiaparelli startled twentieth century women with a sexy scent which she appropriately called *Shocking*. Women flocked to her salon to add the scent in its unique "torso" bottle to their dressing tables. The bottle was said to have been inspired by the measurements of the voluptuous American actress Mae West. It is considered one of the great collectibles in the twenty-first century.

### Peacetime Scent-Sations

A fashion/fragrance explosion following World War II was led by Christian Dior who not only dropped skirts to the floor in 1947 with his *New Look*, but also intrigued his customers with the legendary *Miss Dior* perfume. Nina Ricci introduced her romantic perfume, *L'Air du Temps*, in 1948 in its unforgettable "double doves" bottle. In 1951, the elegant Hubert Givenchy took his place in the perfume pantheon, with *L'Interdit*, inspired by his muse, Audrey Hepburn.

### Hints of Globalization

In the second half of the twentieth century, the French couture world spawned a splendid group of designers including Yves Saint Laurent, Karl Lagerfeld, Guy Laroche, Pierre Cardin, and Paco Rabanne. Before long, all became perfume aficionados as fragrance and fashion became inextricably connected.

Fragrance in the United States, at the time was primarily French and considered a luxury to be worn only on special occasions. An interest in American fragrances began to accelerate when Estée Lauder introduced *Youth Dew* in 1953. The first perfume in an oil base (versus alcohol), it was particularly long lasting and became a nationwide success. The launch of Norell, however, catapulted America into the fashion/fragrance arena. Norell was the first American designer to lend his name to a perfume. Revlon introduced it in 1969. The sophisticated floral became the olfactory touchstone for execu-

tive women throughout the country. It suddenly became *de rigueur* for these career women to keep Norell perfume bottles in full view on their desks.

By the 1970s, American designer fragrances multiplied. Halston led the way with his first fragrance in 1975. Presented in the famed Elsa Peretti bean bottle, it was an immediate favorite. Ralph Lauren set new fragrance standards with *Lauren* and *Polo* in 1978. Calvin Klein rocked the fragrance world in 1985 with *Obsession* and its provocative, risqué advertising. He followed up in 1994 with the first important unisex fragrance, *CK-1*. It created a sensation. America's designers Oscar de la Renta, Liz Claiborne, Bill Blass, and Donna Karan moved quickly to join the fragrance explosion.

### Designing a Fragrant Future

France's commitment to fragrance and its formidable fashion designers also continued unabated. In the 1980s, new cutting-edge designers made their mark: The 1990s witnessed fragrance launches from Jean-Paul Gaultier and Issey Miyake. By the time the century was over, fashion designers from Italy (Armani, Moschino, and Dolce & Gabbana), Spain (Carolina Herrera and Paco Rabanne), and Germany (Jil Sander and Hugo Boss) were international fragrance stars.

In the twenty-first century, competition heated up with fragrance blockbusters from the newest fashion leaders in the United States and abroad: the namesake fragrances of Marc Jacobs, Michael Kors, and Vera Wang have joined John Galiano's Kingdom. The ever-widening development of odor identical molecules and computer-generated techniques that extract and reproduce scents previously undetected or available has dramatically expanded the perfumer's palette. Amongst the original olfactory experiences that emerged are food, oceanic, and ozone notes. Researchers have explored scents emitted by coral growing in the Caribbean. Flowers have been sent into space to determine how the weightlessness impacts the flower's odor stability. Work has been undertaken to develop pleasing odor environments and delivery systems for future space stations. Research has revealed that humans are not comfortable living under odorless or negative odor conditions.

The key to the success of the designer scents has always depended on how well each designer interprets his or her fashion image in the packaging, name, advertising, and, of course, the fragrance. The appeal is especially powerful to the majority of consumers who could not afford the couture designs that appear alluringly in the pages of magazines, in store windows, and on popular TV shows. The perfumes have made it possible for almost everyone to experience the panache of the designers. As a result, designer fragrance successes have multiplied and captured the imagination and dedication of women everywhere.

There are eight basic fragrance categories: Green, single florals, floral bouquet, oriental blend, modern

blend, fruity, spicy, and woody mossy. In recent years, fantasy formulations have grown increasingly popular. These are fragrances that defy description and are olfactory experiences based on the perfumers' imagination.

In the twenty-first century, creating a fragrance demands scientific, technical, and artistic expertise. The time frame from start to finish can be as long as three years. Usually, a team of perfumers, assistants, and evaluators work against what the industry calls a "perfume profile." The profile identifies the type of fragrance (floral, spicy citrus, woody, green, or oriental), the characteristics of the type of woman who would wear the fragrance (sophisticated, conservative, sporty, adventurous), the pricing, the packaging, and among other factors, imagery. A number of perfumers from different supplier companies compete to win the assignment. Once the winning fragrance is selected, it is market-tested, which could take another six to eight months. During this period, the packaging, advertising, marketing, and sales promotion (including sampling) strategies are finalized.

There are only a handful of great perfumers and like all fine artists they are considered key to the success of creating a great luxury brand. They are in demand and remunerated accordingly. Because of the many elements involved in bringing a fragrance to market, there is no hard and fast rule for allocation of costs.

The future promises to expand the rarity and enjoyment of designer-inspired fragrances. New technologies and packaging concepts will make them available in a myriad of forms for personal wear and travel, as well as in the home and in public spaces. The olfactory adventure of the twenty-first century absolutely knows no bounds.

See also **Cosmetics, Nonwestern; Cosmetics, Western.**

#### BIBLIOGRAPHY

- Ackerman, Diane. *A Natural History of the Senses*. New York: Random House, 1990.
- Classen, Constance, ed. *Aroma: The Cultural History of Smell*. London and New York: Routledge, 1994.
- Corbin, Alain, ed. *The Foul and the Fragrant: Odor and the French Social Imagination*. Cambridge, Mass.: Harvard University Press, 1986.
- Cunningham, Donna. *Flower Remedies Handbook: Emotional Healing and Growth: With Bach and Other Flower Essences*. New York: Sterling Publishing Company, 1992.
- Dyett, Linda, and Annette Green. *Secrets of Aromatic Jewelry*. New York: Flammarion, 1998.
- Le Guerier, Annick. *Scent: The Mysterious and Essential Powers of Smell*. Translation by Richard Miller. New York: Turtle Bay Books/Random House, 1992.
- Morris, Edwin T. *The Story of Perfume from Cleopatra to Chanel*. New York: Charles Scribner's Sons, 1984.
- White, Palmer. *Elsa Schiaparelli: Empress of Fashion*. New York: Rizzoli, 1986.

Annette Green

**PERMANENT PRESS.** See **Performance Finishes.**

**PETTICOAT** The petticoat is derived from the *jupe* or underskirt of the eighteenth century. As the skirts of women's robes were open at the front, the *jupe* had to be as highly decorative as the robe, and was often constructed of the same rich material. Around 1715 the petticoat became an undergarment that gave structure to the outer skirt by means of a series of whalebone hoops.

#### The Nineteenth Century

By the nineteenth century, petticoats had several functions. They were used as underlinen to provide warmth and protect outer clothing from an unclean body, to give a structure to the skirt depending on the fashionable silhouette of the time, and to disguise the shape of the legs to give a modest appearance to a woman. It formed part of an extensive range of underwear as worn by the Victorian woman, which was comprised of a chemise, drawers, corset, and several petticoats. Petticoats were generally in two forms until the end of the nineteenth century: a petticoat with a bodice attached or a separate waisted garment which was corded, that is, it had tucks with cords threaded through and drawn in to the waist to provide initial support for the crinoline skirt.

Made out of cotton, linen, cambric, and flannel for winter, several petticoats would be worn at once in the 1840s to provide a bell-shaped structure for the skirt and were stiffened with horsehair at the hem. With the invention of the cage crinoline, petticoats became less structural, and usually only one was worn under the crinoline cage for warmth and modesty as the cage had a habit of flying up when a wearer sat down too rapidly. Another petticoat was customarily worn over the crinoline to soften the steel rings of its outline and tended to have an ornately decorative hem, usually of *broderie anglaise* or crochet as it was likely to be exposed when the wearer was walking. The shape of the petticoat was very much determined by the fashionable shape of outerwear and thus changed over the century from the narrower shapes of the 1860s to the gored cuts of the 1870s and the overly frilled and flounced *froufrou* of the Edwardian Era. The slimmer cut of 1920s fashions and bias cut of the 1930s necessitated a different kind of underwear—usually French knickers and bias-cut slips derived from the petticoat and attached bodice of the nineteenth century.

#### Post-World War II

In 1947 Christian Dior's *Corolle Line*, later dubbed the New Look, heralded the revival of the bouffant skirt, a round crinoline shape with an understructure comprised of several petticoats. The look was incorporated into teenage culture in the 1950s as young women adopted the petticoat and wore several at once—usually of sugar-starched net and paper nylon, or (for evening) taffeta, at least one of which was stiffened with plastic hoops. The

look was particularly associated with rock 'n' roll and jiving as the petticoats preserved the dancer's modesty when exhibiting twirls with her male partner. In the 1960s the petticoat disappeared in daywear and, in much the same way as the corset, became the preserve of fetishism. The allure of the petticoat can be explained by the way it exaggerates certain characteristics of the female body, by emphasizing the hips it highlights a fragile waist. It has thus earned a place in fetish culture as a signifier of femininity, and magazines such as *Petticoat Discipline* allude to the popular cross-dressing scenario of a little boy being forced to parade in front of his family and friends in petticoats as a punishment for some misdemeanor. The frisson of pleasure achieved through shame thus creates a fetishist.

British designer Vivienne Westwood revived the petticoat in the late 1970s and 1980s as a result of theatrical New Romantic dressing and the experiments with the mini-crinini. The wedding of Lady Diana Spencer to Prince Charles in 1981 heralded a revival of the nineteenth-century silhouette in bridal design as a result of her crinoline-skirted wedding gown designed by David and Elizabeth Emanuel. Thus, the contemporary petticoat is often used as an understructure in women's formal wear, in particular bridal gowns and in outfits worn by female country and western singers; Wynona Judd is associated with this look.

See also **Crinoline; Corset; Petticoat; Underwear.**

#### BIBLIOGRAPHY

- Carter, Alison. *Underwear: The Fashion History*. London: Batsford, 1992.
- Cunnington, C. Willet and Phillis. *The History of Underclothes*. London: Dover Publications, 1992.
- Saint-Laurent, Cecil. *History of Women's Underwear*. London: Academy Editions, 1986.

Caroline Cox

**PIMA COTTON.** See **Cotton.**

**PINA CLOTH.** See **Fibers.**

**PINAFORE.** See **Aprons.**

**PINS** Pins range from the simplest devices used by humanity to some of the most elaborately decorated ornaments. Thorns, bones, and other plant and animal materials have been used for making and fastening garments since Neolithic times. Sumerians used iron and bone pins 5000 years ago. Wealthy Egyptians wore straight bronze pins with decorated heads; by Greek and Roman times the fashion had changed to a clasp or fibula. Medieval pins ranged from simple pieces of wood to ivory and silver, and measured 2.5 to 6 inches. Paris was the

center of medieval pin manufacturing; by the seventeenth century, though, pin making was the leading industry of Gloucester, England. Less valuable than needles, metal pins were small luxuries in early modern Europe; pin money was originally a bonus given to a merchant on concluding a deal, for his wife's pins.

By the eighteenth century, pins were made with a division of labor that fascinated both Denis Diderot and Adam Smith because the specialization of workers was helping make a luxury affordable. Steel being too costly and difficult to work, brass wire was drawn at 60 feet per minute by a skilled specialist, then cut into lengths by other workers producing 4,200 pins an hour. Others then sharpened the points and made coiled brass into heads and affixed them, coated the pins with tin, and washed, dried, and polished them. A single worker going through all these stages would have been able to make only a handful of pins a day. Mechanized pin production began in Birmingham, England, in 1838. One of the most celebrated devices of antebellum America, John Howe's 1841 pin machine made a breakthrough in automation by performing the entire sequence of unwinding wire, cutting, grinding, and polishing in a single rotational sequence. It even formed heads by compressing one end of the wire.

Pins were one of the first articles so effectively automated that the challenge shifted from production to packing—especially inserting the pins rapidly and safely in crimped paper cards—and marketing. The card display, developed by Howe, assured customers of the quality of metal, points, and heads. In 1900 U.S. residents used 60 million common pins, or about 126 per capita; old obstacles to working with steel had been overcome. By 1980, a Cambridge University economist estimated that productivity per worker in the British pin industry had increased 167-fold in 200 years.

Perhaps the greatest impact of abundant, cheap, high-quality pins packed in closed cases was on the culture of sewing. Pins no longer had to be protected from theft, loss, and rust. Through peddlers, they were available to every country household, and their profusion helped pincushions reach a decorative peak in the Victorian era. By the early twenty-first century, pins had lost most of their industrial importance; only in luxury production and in-home sewing were they still used to attach patterns to fabric.

See also **Brooches and Pins; Needles; Safety Pins.**

#### BIBLIOGRAPHY

- Andere, Mary. *Old Needlework Boxes and Tools*. New York: Drake Publications Ltd., 1971.
- Gillispie, Charles C., ed. *A Diderot Pictorial Encyclopedia of Trades and Industry*. Volume 1. New York: Dover Publications, Inc., 1987. See plates 185–187.
- Lubar, Steven. "Culture and Technological Design in the Nineteenth-century Pin Industry: John Howe and the Howe



Manufacturing Company." *Technology and Culture* 28, no. 2 (April 1987): 253–282.

Petroski, Henry. *The Evolution of Useful Things*. New York: Alfred A. Knopf, 1992.

*Edward Tenner*

**PIQUE.** *See Weave, Jacquard.*

**PLAID** Checked cloths were evident in many early cultures, however, the term plaid derives from Scottish Celtic culture of around the sixteenth and seventeenth centuries (Bonfante 1975; Barber 1991; Cheape 1995). The popularity of checked cloths in North America and the use of the word plaid to describe these cloths are almost certainly linked to the influence of Scottish immigrants from the late eighteenth century onward. The term is widely used in North America to describe a diverse range of checked cloths from heavy tartans and tweeds to fresh cotton gingham. However, within Britain, plaid generally refers to either tartan or checked cloths similar to tartan. It also signifies a length of tartan cloth worn over the shoulder as part of the more elaborate forms of Highland Dress.

#### Origins in Celtic Culture

In the early Celtic culture of Scotland and Ireland, a type of shaped cloak known as a mantle was worn. In the sixteenth and seventeenth centuries, this developed into the simple, untailed length of cloth known as the plaid. Cheape further identifies that “plaids or plaiding were Scots terms used to describe the relatively coarse woven twilled cloth that might be used, for example, for bed coverings as well as garments” (p. 19). Indeed the Gaelic meaning for the word *plaidie* is blanket, whereas the plaid as a garment tends to be referred to as a *breacan*, the belted



#### THE WOMEN OF EDINBURGH

Sir William Brereton, an English visitor to Edinburgh in 1636, described the dress of women as follows:

Many wear (especially of the meaner sort) plaids, which is a garment of the same woollen stuff whereof saddle cloths in England are made, which is cast over their heads, and covers their faces on both sides, and would reach almost to the ground, but that they pluck them up, and wear them cast under their arms. (Cheape, p. 19)



**Clair McCardell plaid playsuit.** Scottish immigrants brought plaids to North America in the late eighteenth century, and the pattern has since become a popular one in modern design collections. [MODEL BIJOU BARRINGTON IN CLAIRE MCCARDELL "ROMPER"], HARPER'S BAZAAR, p46, 1942. PHOTOGRAPH BY LOUISE DAHL-WOLFE. © LOUISE DAHL-WOLFE ARCHIVE, CENTER FOR CREATIVE PHOTOGRAPHY, ARIZONA BOARD OF REGENTS. REPRODUCED BY PERMISSION.

plaid, which was commonly worn by men in Highland Scotland. Women throughout Scotland wore the plaid as a large tartan shawl, a style that was popular until the mid-eighteenth century (Dunbar 1981, p. 125; Cheape 1995, pp. 3–20).

#### Plaid in Fashion

By the early nineteenth century, plaids in their original form were scarcely worn, though; in that era plaid cloth gained an international profile as a fashion textile. American mail-order catalogs from the nineteenth century indicate that plaids were popular for men's work-wear and day wear, and for making women and children's dresses and blouses (Israel 1976; Kidwell and Christman 1974, p. 58). The colorful, geometric designs concerned have become embraced within modern, sporting, or “homely pioneer” notions of American sartorial identity. This is linked to the fact that plaid shirts and jackets form part of the image of American male stereotypes such as lumberjacks and frontiersmen. It is also connected to the influential work of American sportswear designers like Claire McCardell and Mildred Orrick, who frequently

used plaids in their designs of the mid-twentieth century (Milbank 1989; Yohannan and Nolf 1998). The embrace of plaid within American culture has influenced subsequent reinterpretations of it. For example, plaid has featured in cowboy, and work wear—inspired gay styles of the 1970s onward, as well as in the subcultural styles of skinheads, rockabillys, and punks. Plaid has also featured consistently in international designer collections, particularly since the 1970s.

See also **Scottish Dress; Tartan.**

#### BIBLIOGRAPHY

- Barber, E. J. W. *Prehistoric Textiles: The Development of Cloth in the Neolithic and Bronze Ages, with Special Reference to the Aegean*. Princeton, N.J.: Princeton University Press, 1991.
- Bonfante, Larissa. *Etruscan Dress*. Baltimore: Johns Hopkins University Press, 1976.
- Cheape, Hugh. *Tartan: The Highland Habit*. Edinburgh: National Museums of Scotland, 1995.
- Dunbar, J. Telfer. *The Costume of Scotland*. London: B.T. Batsford, Ltd., 1981.
- Israel, Fred. *1897 Sears Roebuck Catalogue*. New York: Chelsea House Publishers, 1976.
- Kidwell, C., and M. Christman, eds. *Suiting Everyone: The Democratization of Clothing in America*. Washington D.C.: Smithsonian Institution Press, 1974.
- Milbank, Caroline Reynolds. *New York Fashion: The Evolution of American Style*. New York: Harry N. Abrams, 1989.
- Yohannan, Kohle, and Nancy Nolf. *Claire McCardell: Redefining Modernism*. New York: Harry N. Abrams, 1998.

Fiona Anderson

**PLASTIC AND COSMETIC SURGERY** Cosmetic surgery began to be practiced in the last part of the nineteenth century as surgical intervention became increasingly possible because of the development of anesthesia and sterile techniques. One of the first cases to be reported in the last part of the nineteenth century had to do with correcting what was known as saddle nose, a deep depression in the middle of the nose. There are several causes of this condition, but one of them was syphilis. This association with syphilis made those with such noses particularly willing to try to get some surgical change. Large noses were also an issue and intranasal rhinoplasty (hiding the incisions inside the nose) was first done in the 1880s.

Public knowledge of the possibility of plastic surgery came during World War I (1914–1918) as surgeons treated patients in unprecedented number with bad facial and other visible scars. The “miracles” wrought by the surgeons brought plastic surgery out of the closet, and there were enough physicians engaged in it to found the American Association of Oral Surgeons in 1921, later called the American Association of Oral and Plastic Sur-

geons, and still later, the American Association of Plastic Surgeons.

These early-organized plastic surgeons were cautious about their reconstructive surgery, determined to use their skills to help the maimed but not to do frivolous surgery designed to make people more “beautiful.” Not all would-be surgeons agreed with them, and a separate group popularly called “beauty surgeons” developed. These surgeons were looked down upon for their promises to improve the looks of their patients. They took shortcuts, avoiding some of the time-consuming operations involving bone and cartilage grafts. Instead, they relied upon the injection of paraffin, which for a time in the 1920s, was seen as a panacea for all soft-tissue defects. It was widely used to fill facial wrinkles. Unfortunately paraffin had a tendency to migrate to other areas, particularly if the patient spent time in the sun. That tended to disfigure the patient, who then had to go through the process again. One of the best known of these beauty surgeons was Charles C. Miller of Chicago, who wrote an early textbook entitled *Cosmetic Surgery: The Correction of Featural Imperfections*.

The attempt to distinguish between plastic surgery and beauty essentially failed. While surgery was still done for people whose bodily features had been altered by wounds or fires, increasingly it was used to meet personal beauty standards or to change identifiable ethnic features or to make someone appear younger by removing facial wrinkles or having eye tucks. Surgery was also done to change the contours of the body, particularly among women where breast augmentation or breast reduction became an important specialty. By 1988 breast enlargement surgery had become a \$300 million business. Some urologists got into the business of penile augmentation, although this was far more controversial. One San Francisco urologist in the 1990s claimed to have done 3,500 such operations even though many urologists condemned the operations as unnecessary and potentially dangerous.

Silicone implants gave a big boost to the breast augmentation industry, and it became second only to liposuction (fat removal) as the most common cosmetic surgery. Some women complained that the silicone in their breast implants ruptured or leaked, causing them to have chronic fatigue, arthritis, and damage to the immune system. The result was a lawsuit that resulted in the largest fee ever negotiated in a class-action lawsuit. Dow Corning, Bristol-Myers Squibb Company, and others agreed to pay more \$4 billion to 25,000 women. Breast-implant surgery grew even more prevalent, however, when the silicone was replaced by saline. Still the silicone worked better and research both before the lawsuit and after has tended to disprove the validity of the claims about the dangers of silicone. In 2003 there was an unsuccessful campaign to return to silicone as an option. The last word, however, has not been said on this issue.

While many women want to increase the size of their breasts, others want to lessen theirs, and breast reduction remains an important part of cosmetic surgery. By 1992, 40,000 women a year were having reduction surgery.

Probably the most radical of plastic or cosmetic surgery is that involved in transsexual surgery. Surgery to change males to female has changed drastically in the last 40 years, and skilled surgeons can use the penis and testicles to make functional labia and vaginas. The surgery for changing females to males is less well-developed since it has proved difficult to make a penis that can be used for both urination and sexual intercourse, but research is still continuing in the field.

See also **Body Building and Sculpting; Body Piercing; Branding; Implants; Scarification; Tattoos.**

#### BIBLIOGRAPHY

- Haiken, Beth. "Plastic Surgery and American Beauty at 1921." *Bulletin of the History of Medicine* 68 (1994): 429–453.
- Haiken, Elizabeth. *Venus Envy: A History of Cosmetic Surgery*. Baltimore, Md.: Johns Hopkins University Press, 1997.
- Miller, Charles C. *Cosmetic Surgery: The Correction of Featural Imperfections*. Chicago: Oak Printing Company, 1907.
- Yalom, Marilyn. *A History of the Breast*. New York: Alfred A. Knopf, 1998.

Vern L. Bullough

**PLAITING.** See **Braiding.**

**PLEATHER.** See **Techno-Textiles.**

**PLUSH.** See **Weave, Pile.**

**POCKETS** Pockets are a small but important component of western clothing. Despite their deceptive obscurity and utilitarian nature, pockets are sensitive to fashion changes and they can reveal a wealth of social and cultural information. Pockets are an alternative or supplement to bags, purses, and pouches in the carrying and securing of portable personal possessions, and historically it is often illuminating to consider them together. There has been a close gender-specific association between pockets and the bodily gestures and posture they facilitate. In the period before mass-produced clothing, first for men and then for women, there was scope for individual customers, or their tailors and dressmakers, to choose where pockets should be placed, and though there were common preferences and styles, pockets were by no means uniform; in the early twenty-first century, the same applies in expensive bespoke clothing. There has always



"...because I have no safer a store-house, these pockets do serve me for a roome to lay up my goods in, and though it be a straight prison, yet it is a store-house big enough for them, for I have many things more of value yet within..." (Bulwer, p. 77).

been a difference in the number and position of pockets customarily provided for men, women, and children.

#### Pockets in Men's Dress

For men, the most prominent pockets are those on the outside of their coats. In the seventeenth century, they had been close to the lower edge and then moved higher. In the eighteenth century, like pockets in waistcoats, they became marked out by flaps becoming deeper and often decorative, sometimes lavishly so in keeping with the color and embellishment of fashionable garments. The great coat, which was common before the railway age, provided a capacious range of pockets suitable for the needs of male travelers. Its demise may have contributed to the widespread adoption of the briefcase in the twentieth century by businessmen and commuters. In the voluminous trunk hose worn by men with doublets in the sixteenth and seventeenth centuries, very large pockets could be accessed from the side. Pockets in later styles of breeches and trousers have been situated in the side seams, but also at the back and front.

Smaller pockets, such as those for coins or hanging watches, were less visible, for example placed in the front of the waistband of breeches; chamois leather was sometimes used as lining. Watches became small enough at the start of the seventeenth century to be concealed in pockets made for the purpose. These remained common until the wristwatch became popular in the twentieth century. The inside top pocket is commonly found in many male garments past and present. Men's garments utilized integrated pockets and positioned them to achieve balance across the body generally before women's garments did so. The number of pockets for men has been substantial. Extant historical breeches and trousers show evidence of the cycle of patching made necessary by wear and tear caused to pocket linings by coins and keys, a problem that has continued.

#### Pockets in Women's Dress

Women's clothing was slower to adopt the integral pockets widely used by men. The old-established custom of hanging small utensils and tools from the belt has never entirely ceased. It enjoyed a renaissance amongst women in the second half of the nineteenth century when there





“At the present time men and women employ quite different systems, men carrying what is needful in their pockets, women in bags which are not attached in any way to their persons, but carried loosely in their hands. Both systems have serious disadvantages” (Flügel, p. 186).

was a vogue for antique-looking chatelaines. Throughout the eighteenth century, women commonly had slits in the sides of the skirts of their gowns and informal jackets to gain access to tie-on or hanging pockets worn beneath. These large pockets were made in pairs or singly, usually with vertical slit openings and worn on a tape around the waist, independent of the garments worn over them, and consisted of linen, cotton, silk, or materials recycled from older furnishings or patchwork. In the eighteenth century these were also often beautifully embroidered, but this practice seems to have ceased in the nineteenth century. Integral pockets then became more popular; bags and reticules of various kinds supplemented capacity for carrying small personal possessions, but tie-on pockets continued in use throughout the nineteenth century, when later they were often associated with children, or of rural or working-class women, and they disappeared altogether by the 1920s.

Integral pockets were distributed in various places in formal and informal dresses and suits, between skirt gores, even in folds over the bustle drapes. Patch pockets have been prominent on aprons, both the decorative ones fashionable amongst women of leisure in the eighteenth century, and the utilitarian aprons found in many situations throughout the period. In the twentieth century, the use of trousers and jeans by women has provided them with more pockets, but rarely have women's coats or jackets been made with the useful inside pocket so typical of menswear. In periods of history where women and girls have had little or no domestic privacy or financial independence, pockets (as well as stays) have provided them with one of the few available forms of security and privacy for letters, money, or other small possessions.

### Social and Cultural Factors

Both men and women have faced the conflict of interest inherent in retaining fashionable, smooth outlines to their garments whilst carrying things in their pockets. Changes in the type and number of pockets for both sexes derive both from fashion and from the necessity to accommodate different kinds of things, ranging from a woman's snuffbox of the eighteenth century to car keys

in more recent times. These goods are expressive of gender roles and social class. However, despite the wide range of types of pockets available, they have not been entirely effective for men or women. There have been frequent complaints over the last three centuries about their inadequacy or inaccessibility and, paradoxically, court records and newspapers over this time show the frequency with which pickpockets and pocket snatchers found them only too accessible. Tie-on pockets were sometimes lost, a loss suffered by Lucy Locket and described in a nursery rhyme:

Lucy Locket lost her pocket,  
Kitty Fisher found it,  
Not a penny was there in it,  
Only ribbon round it. (Opie, p. 279)

Some small possessions have generated their own carrying devices worn separately, such as holsters for small arms, specialist aprons to carry small tools for skilled trades, and binocular cases. Latterly conventional pockets have been to some extent superseded by small bags, based on hiking gear, worn around the waist or on the back by both sexes, but innovation in pockets still continues. They are seen sited in unconventional positions, sometimes borrowed from combat clothing or used to accommodate new urban lifestyles and technological innovations such as mobile phones and computer games. This suggests that there is sufficient need for pockets not only to continue in use, but also to attract inventive new solutions.

See also **Handbags and Purses; Trousers; Watches.**

### BIBLIOGRAPHY

- Arnold, Janet. *Patterns of Fashion: Englishwomen's Dresses and Their Construction c. 1660–1860*. London: Macmillan, 1977.
- . *Patterns of Fashion: The Cut and Construction of Clothes for Men and Women c. 1560–1620*. London: Macmillan, 1985.
- Baumgarten, Linda, and John Watson. *Costume Close-up: Clothing Construction and Pattern 1750–1790*, Williamsburg, Va.: Colonial Williamsburg Foundation with Quite Specific Media Group, 1999.
- Bradfield, Nancy. *Costume in Detail, 1730–1930*. London: Harrap, 1968.
- Bulwer, John. *Anthropometamorphosis: Man Transform'd or The Artificial Changeling*. London: Printed by W. Hunt, 1653.
- Burman, Barbara. “Pocketing the Difference: Pockets and Gender in Nineteenth-Century Britain.” In *Material Strategies: Dress and Gender in Historical Perspective*. Edited by Barbara Burman and Carole Turbin. Oxford: Blackwell, 2003.
- Flügel, J. C. *The Psychology of Clothes*. New York: International Universities Press, 1969 (first published 1930), p. 186.
- Opie, Iona, and Peter Opie, eds. *The Oxford Dictionary of Nursery Rhymes*. Oxford: Clarendon Press.

Barbara Burman

**POINTE SHOES** Pointe shoes, also known as toe shoes, represent an essential part of the ballet dancer's costume. The aesthetic concept of ballet calls for a long line in the leg, which is further enhanced by the nearly conical shape of a pointe shoe.

### The Birth of Pointe Shoes

In the early 1700s, ballet technique developed rapidly and incorporated a new emphasis on graceful foot technique. In 1726, Marie Camargo debuted at the Paris Opéra Ballet in a performance of *Les Caractères de la Danse*, dancing in slippers instead of heeled shoes. She had also shortened her stage skirt to show off the turnout of her legs and feet. After the French Revolution in 1789, emphasis was placed on the functional aspect of stage costumes in order to facilitate the fully extended pointing of the foot during turns and jumps. Accordingly, short-soled slippers with pleats under the toes became standard footwear for ballet dancers. At the beginning of the nineteenth century, an increasingly challenging ballet technique, *en demi pointe*, allowed dancers to carry out multiple pirouettes and jumps. While men were identified as playing a secondary role in the performance, from this point onward ballerinas rose to the toes and contributed to a new dance aesthetic. This overt emphasis on the lightness of dancers was reflected by Marie Taglioni, who appeared *sur les pointes* in the first performance of *La Sylphide* in 1832. Some early examples of pointe shoes from this period are exhibited in the Haydn Museum in Austria.

The introduction of pointe has related to the development of narrative ballets, allowing for and responding to ethereal elements, like the mystic sylphs in *La Sylphide* (1832), the suggestion of dramatic ethereality in *Giselle* (1841), and the enchanted swans in *Swan Lake* (1895). By the end of the nineteenth century, the pointe technique was highly developed. Being tied entirely to the growing challenge of pointe work, Pierina Legnani introduced thirty-two *fouettés* in a performance of *Swan Lake*. In 1905, toe dancing reached a new high point when Anna Pawlowa portrayed *The Dying Swan*—a three minute solo—constantly *en pointe bourrée*. Although Pawlowa is said to have used pointe shoes with wider platforms, which she was supposed to have covered up in photographs to look narrower, she brought a new dimension of pointe dance into the twentieth century.

Les Ballets Russes, which emerged from 1909 until 1929 under the direction of Sergei Diaghilev, developed ballet *en pointe* to a very high technical level. In 1931, Russian teenage ballerinas performed sixty-four *fouettés en pointe*, six unsupported pirouettes, thus setting an extremely high standard in classical ballet. Russian pointe shoes, which are said to be softer than their American or British counterparts, contributed to a growing demand for these shoes within other companies. After the end of World War I, when modern dance groups emerged, dance moved away from traditional ballet techniques and

pointe work and modern dance gave rise to a new era of costuming and dance footwear, and in modern dance pointe shoes were completely abandoned.

### The Making of Pointe Shoes

Traditionally, pointe shoes are sewn inside out. The shoe is only turned to the right side after the toe block has been constructed. The constructing of a pointe shoe requires a pre-cut piece of satin and lining (which will form the upper part of the shoe), and the insertion of a vamp section (which will form the sole of the shoe). Peach pink shades remain the traditional color for pointe shoes, implying the illusion of an extended leg. Pointe shoes have no right or left. The craftsman will use a special glue formula (based on a simple flour and water paste) to form the block. The shoes enter a hardening process in a hot-air oven. Finally, the excess cloth is trimmed and the insole is attached with glue. The dancer herself undertakes the last step: Four pieces of ribbon are sewn onto the insides of a pair of shoes. Pointe shoe dancers usually experiment with the right placement of the ribbons in order to give maximum hold. To extend the short life of a pointe shoe, the ballerina will bake them and apply resin, floor wax, or super glue before she “breaks-in” the shoes to make them feel like a second skin. The altering caused by “breaking-in” can often shorten the life of a shoe by 50 percent.

### New Technology versus Old Traditions

In the last few decades of the twentieth century, the technical requirements of ballet rapidly increased. This resulted in a demand for more elaborate pointe shoes. A wide range of designs were on the market: from soft block shoes, which are designed for transition from soft shoes to pointe shoes, to extremely hard shoes, which give extra strength, to machine-manufactured rehearsal pointes for dance students operating on a smaller budget. About thirty-five ballet shoe manufacturers, such as Freed, Capezio, and Gaynor Minden, operate in the market, but as a result of a long history of traditional pointe shoe manufacturing with cardboard and simple flour and water paste glue, the innovative pointe shoe with unbreakable shanks produced by the U.S. ballet shoe manufacturer Gaynor Minden are ubiquitous. At the end of the twentieth century, the fashion industry picked up the idea of ribbons and look-alike pointe shoes, and designer brands such as Manolo Blahnik, Sonia Rykiel, Etro, and Blumarine have used the pointe shoe style to create “ballerina” fashion shoes.

See also **Ballet Costume; Shoes; Theatrical Costume.**

### BIBLIOGRAPHY

- Barringer, Janice and Schlesinger Sarah. *The Pointe Book: Shoes, Training & Technique*. Hightstown, N.J.: Princeton Book Company, 1990.
- Bentley, Tony. *The Heart and Sole of a Ballerina's Art: Her Toe Shoes*. Washington, D.C.: Smithsonian Institution, 1984.

Cunningham, B. W. et al. "A Comparative Mechanical Analysis of the Pointe Shoe Toe Box." *American Journal of Sports Medicine* 26, no. 4 (1998): 555–561.

Terry, Walter. *On Pointe*. New York: Dodd Mead, 1962.

Trucco, Terry. "To the Pointe." *Ballet News* 3 (1982): 21.

*Internet Resource*

Brown, Ismene. "Arch Rivals." *Telegraph*. 8 March 2003. Available from <<http://www.art.telegraph.co.uk>>.

Thomas Hecht

**POIRET, PAUL** Before Paul Poiret (1879–1944), there was the *couture*: clothing whose *raison d'être* was beauty as well as the display of wealth and taste. Paul Poiret brought a new element of fashion to the *couture*; thanks to him fashion can be a mirror of the times, an art form, and a grand entertainment. Poiret, in the opinion of many, was fashion's first genius.



**Paul Poiret, 1922.** On a shipdeck in New York City, Paul Poiret stands with his arms spread wide open. Poiret, who infused fashion with art and broke down nineteenth-century conventional clothing styles, is considered by many to be fashion's first "genius." © UNDERWOOD & UNDERWOOD/CORBIS. REPRODUCED BY PERMISSION.

Born into a solidly bourgeois Parisian family (his father, Auguste Poiret, was a respectable cloth merchant), Poiret attended a Catholic *lycée*, finishing as was typical in his early teens. Following school came an apprenticeship to an umbrella maker, a *métier* that did not suit him. At the time, it was possible to begin a *couture* career by shopping around one's drawings of original fashion designs. *Couture* houses purchased these to use as inspiration. Poiret's first encouragement came when Mme. Chéruit, a good but minor *couturière*, bought a dozen of his designs. He was still a teenager when, in 1896, he began working for Jacques Doucet, one of Paris's most prominent *couturiers*.

Auspiciously, Doucet sold four hundred copies of one of Poiret's first designs, a simple red cape with gray lining and revers. And in four years there, the novice designer rose up in the ranks to become head of the tailoring department. His greatest coup was making an evening coat to be worn by the great actress Réjane in a play called *Zaza*. The biggest splash fashion could make in those days was on the stage, and Poiret made sure to design something attention-worthy: a mantle of black tulle over black taffeta painted with large-scale iris by a well-known fan painter. Next came the custom of more actresses, and then, while working on the play *L'Aiglon* starring Sarah Bernhardt, Poiret snuck into a dress rehearsal where his scathing critique of the sets and costumes were overheard by the playwright, costing him his job. (The remarks could not have alienated Madame Bernhardt, as he would dress her for several 1912 films.) He fulfilled his military service during the next year and then joined Worth, the top *couture* house as an assistant designer in 1901. There he was given a *sous chef* job of creating what Jean Worth (grandson of the founder) called the "fried potatoes," meaning the side dish to Worth's main course of lavish evening and reception gowns. Poiret was responsible for the kind of serviceable, simple clothes needed by women who took the bus as opposed to languishing in a carriage, and while he felt himself to be looked down on by his fellow workers, his designs were commercial successes.

In September 1903 he opened his own *couture* house on the avenue Auber (corner of the rue Scribe). There he quickly attracted the custom of such former clients as the actress Réjane. In 1905 he married Denise Boulet, the daughter of a textile manufacturer, whose waiflike figure and nonconventional looks would change the way he designed. In 1906 Poiret moved into 37, rue Pasquier, and by 1909 he was able to relocate to quite grand quarters: a large eighteenth-century *hôtel particulier* at 9 avenue d'Antin (perpendicular to the Faubourg Saint-Honoré and since World War II known as Avenue Franklin-Roosevelt). The architect Louis Suë oversaw the renovations; the spectacular open grounds included a *parterre* garden. Poiret also purchased two adjoining buildings on the Faubourg St. Honore, which he later established as Martine and Rosine.





### THE POIRET ROSE

While there are some designers associated with specific flowers (Chanel and the camellia, Dior and the lily-of-the-valley) no one can claim the achievement of having reinvented a flower in such a way as to have it always identified with them. The Poiret rose (reduced to its simplest elements of overlapping curving lines) may have appeared for the first time in the form of a three-dimensional silk chiffon flower sewn to the empire bodice of Josephine, one of the 1907 dresses featured in the 1908 album *Les Robes de Paul Poiret*. Flat versions of the Poiret rose, embroidered in beads, appeared on the minaret tunic of the well-known dress Sorbet, 1913. Poiret's characteristically large and showy label also featured a rose.

### Les Robes of Paul Poiret

Until the October 1908 publication of *Les Robes de Paul Poiret*, Poiret was merely an up-and-coming couturier, likely to assume a place in the hierarchy as secure as that of Doucet or Worth. However, the limited edition deluxe album of Poiret designs as envisioned and exquisitely rendered by new artist Paul Iribe would have far-reaching impact, placing Poiret in a new uncharted position, that of daringly inventive designer and arbiter of taste. Fashion presentation up to then had been quite straightforward: magazines showed clothes in a variety of media, based on what was possible technically: black-and-white sketches, hand-colored woodblock prints, or colored lithographs, and, in the case of the French magazine *Les Modes*, black-and-white photographs or pastel-tinted black-and-white photographs. The poses were typical photographer's studio ones, carefully posed models against a muted ground, vaguely landscape or interior in feeling.

Using the pochoir method of printing, resulting in brilliantly saturated areas of color, Paul Iribe juxtaposed Poiret's graphically striking clothes against stylishly arranged backgrounds including pieces of antique furniture, decorative works of art, and old master paintings. The dresses, depicted in color, popped out from the black-and-white backgrounds. This inventive approach was tremendously influential, not only affecting future fashion illustration and photography, but cementing the relationship between art and fashion and probably inspiring the launch of such exquisitely conceived publications as the *Gazette du Bon Ton*.

The dresses were no less newsworthy and influential. When Poiret introduced his lean, high-waisted silhouette of 1908, it was the first time (but hardly the last) that a

radically new fashion would be based fairly literally on the past. The dresses, primarily for evening, feature narrow lines, high waists, covered arms, low décolletés. Their inspiration is both Directoire and medieval. In abandoning the bifurcated figure of the turn of the twentieth century, Poiret looked back to a time when revolutionary dress itself was referencing ancient times. Suddenly the hourglass silhouette was passé.

### Poiret, Bakst, and Orientalism

Poiret had an affinity with all things Eastern, claiming to have been a Persian prince in a previous life. Significantly, the first Asian-inspired piece he ever designed, while still at Worth, was controversial. A simple Chinese-style cloak called Confucius, it offended the occidental sensibilities of an important client, a Russian princess. To her grand eyes it seemed shockingly simple, the kind of thing a peasant might wear; when Poiret opened his own establishment such mandarin-robe-style cloaks would be best-sellers.

The year 1910 was a watershed for orientalism in fashion and the arts. In June, the Ballet Russe performed *Scheherazade* at the Paris Opera, with sets and costumes by Leon Bakst. Its effect on the world of design was immediate. Those who saw the production or Bakst's watercolor sketches reproduced in such luxurious journals as *Art et Decoration* (in 1911) were dazzled by the daring color combinations and swirling profusion of patterns. Since the belle époque could be said to have been defined by the delicate, subtle tints of the impressionists, such a use of color would be seen as groundbreaking.

Although color and pattern were what people talked about, they serve to obscure the most daring aspect of the Ballet Russe costumes: the sheerness (not to mention scantiness) of the materials. Even in the drawings published in 1911, nipples can be seen through sheer silk bodices, and not just legs, but thighs in harem trousers. Midribs, male and female, were bare altogether. Whether inspired or reinforced by Bakst, certain near-Eastern effects: the softly ballooning legs, turbans, and the surplize neckline and tunic effect became Poiret signatures.

The cover of *Les Modes* for April 1912 featured a Georges Barbier illustration of two Poiret enchantresses in a moonlit garden, one dressed in the sort of boldly patterned cocoon wraps for which Poiret would be known throughout his career, the other in a soft evening dress with high waist, below-the-knee-length overskirt, narrow trailing underskirt, the bodice sheer enough to reveal the nipples.

While Poiret's claim to have single-handedly banished the Edwardian palette of swooning mauves can be viewed as egotistical, given Bakst's tremendous influence, his assertions about doing away with the corset have more validity. In each of the numerous photographs of Denise Poiret she is dressed in a fluid slide of fabric; there is no evidence of the lumps and bumps of corsets and other underpinnings. Corsetry and sheerness are hardly compatible and boning would interrupt Poiret's narrow lines.

### The Jupe-Culotte

In the course of producing his (hugely successful) second album of designs *Les Choses de Paul Poiret* (1911), Poiret asked his latest discovery, the artist Georges Lepape, to come up with an idea for a new look. It was Mme. Lepape who sketched her idea of a modern costume and put it in her husband's pocket. When Poiret asked where the new idea was, Lepape had to be reminded to fish it out. The next time they met, Poiret surprised the couple with a mannequin wearing his version of their design: a long tunic with boat neck and high waist worn over dark pants gathered into cuffs at the ankle. And so, at the end of the album under the heading: Tomorrow's Fashions, there appeared several dress/trouser hybrids, which would become known as *jupe-culottes*.

The jupe-culotte caused an international sensation. The Victorian age had left the sexes cemented in rigid roles easily visible in their dress—men in the drab yet freeing uniform of business, and women in an almost literal gilded cage of whalebone and steel, brocade and lace. While Poiret's impulse seems to have been primarily aesthetic, the fact that it coincided with the crusade of suffragists taking up where Amelia Bloomer had left off, served to bring about a real change in how women dressed. For months anything relating to the jupe-culotte was major news. In its most common incarnation, a kind of high-waisted evening dress with tunic lines revealing soft chiffon harem pants, the jupe-culotte was wildly unmodern, requiring the help of a maid to get in and out of and utterly impractical for anything other than looking au courant. Poiret did design numerous more tailored versions, however, often featuring military details and his favorite checked or striped materials; these do look ahead (about fifty years) to the high-fashion trouser suit.

### Martine

In the space of five years, Poiret had become a world-renown success. Now came another influential act. Martine, named after one of Poiret's daughters, opened 1 April 1911 as a school of decorative art. Poiret admitted to being inspired by his 1910 visit to the Wiener Werkstätte, but his idea for Martine entailed a place where imagination could flourish as opposed to being disciplined in a certain style. Young girls, who, in their early teens had finished their traditional schooling, became the pupils. Their assignment was to visit zoos, gardens, the aquarium, and markets and make rough sketches. Their sketches were then developed into decorative motifs. Once a wall full of studies had been completed, Poiret would invite artist colleagues and wallpaper, textile, or embroidery specialists for a kind of critique. The students were rewarded for selected designs, but also got to see their work turned into such Martine wares as rugs, china, pottery, wallpaper, textiles for interiors, and fashions. The Salon d'Automne of 1912 displayed many such items made after designs of the École Martine and Poiret opened a Martine store at 107, Faubourg Saint-Honoré.

Within a few years, a typical Martine style of interior had been developed, juxtaposing spare, simple shapes with large-scale native designs inspired in the main from nature. A 1914 bathroom featured micro-mosaic tiles turning the floor, sink case, and tub into a continuous smooth expanse punctuated by murals or tile panels patterned with stylized grapes on the vine. There were Martine departments in shops all over Europe; although more decorative than what would become known as art deco and art moderne, Martine deserves an early place in the chronology of modern furniture and interior design.

Also in 1911 Poiret inaugurated a perfume concern, naming it after another daughter, Rosine, and locating it at the same address as Martine. Poiret's visionary aesthetic was perfectly suited to the world of scents and he was involved in every aspect of the bottle design, packaging, and advertising, including the Rosine advertising fans. He was also interested in new developments of synthetic scents and in expanding the idea of what is a fragrance by adding lotions, cosmetics, and soaps. Fellow couturiers like Babani, the Callot Soeurs, Chanel, and Patou were among the first to follow suit; thanks to Poiret, perfumes continue to be an integral part of the image (and business) of a fashion house.

### Poiret the Showman

At a time when the runway had yet to be invented and clothes were shown on models in intimate settings in couture houses, Poiret's 1911 and 1914 promotional tours of Europe with models wearing his latest designs made a tremendous splash.

On 24 June 1911 the renowned 1,002-night ball was held in the avenue d'Antin garden featuring Paul Poiret as sultan and Denise Poiret as the sultan's favorite in a combination of two of Poiret's greatest hits, a jupe-culotte with a minaret tunic. The invitations specified how the guests should dress: Dunoyer de Segonzac was told to come as Champagne, His Majesty's Valet and Raoul Dufy as The King's Fool. If one of the 300 guests showed up in Chinese (or, worse, conventional evening) dress, he or she was sent to a wardrobe room to be decked out in Persian taste. Although fancy dress balls had been all the rage for several decades, this one seems to have struck a chord; perhaps it was the first hugely luxurious (champagne, oysters, and other delicacies flowed freely) event staged by a creative person (in trade no less) rather than an aristocrat. Future fêtes, each with a carefully thought-out theme, failed to achieve the same level of excitement. After the war, Poiret's thoughts had turned toward increasingly zany moneymaking ventures. The nightclub was the latest diversion after World War I and Poiret turned his garden first into a nightspot, and then in 1921 it became an open-air theater, Oasis, with a retractable roof devised for him by the automobile manufacturer Voisin. This venture lasted six months.

His last truly notable bit of showmanship was his display at the 1925 Paris Exposition des Arts Décoratifs et

Industriels. Rather than set up a display in an approved location in an official building, Poiret installed three barges on the Seine. Decorated in patriotic French colors, *Delices* was a restaurant decorated with red anemones; *Amours* was decorated with blue Martine carnations; and *Orgues* was white featuring fourteen canvases by Dufy depicting regattas at Le Havre, Ile de France, Deauville; and races at Longchamps, showing some of Poiret's last dress designs under his own label. It was clear that his zest for ideas was being directed elsewhere other than fashion. Typically over the top, he also commissioned a merry-go-round on which one could ride figures of Parisian life, including him and his *midinettes*, or shop-girls.

### The Poiret Milieu

Poiret's interest in the fine, contemporary arts of the day began while he was still quite young. His artist friends included Francis Picabia and André Derain, who painted his portrait when they were both serving in the French army in 1914. His sisters were Nicole Groult, married to Andre Groult, the modern furniture designer; and Mme. Boivin, the jeweler; another was a poet. Besides discovering Paul Iribe and Georges Barbier, he reinvigorated the career of Raoul Dufy by commissioning woodcut-based fabric designs from him and starting him off on a long career in textile design and giving new life to his paintings as well. Bernard Boutet de Monvel worked on numerous early projects for Poiret, including, curiously, writing catalog copy for his perfume brochures. While quite young, Erté saw (and sketched) Poiret's mannequins in Russia in 1911; after emigrating to Paris he worked as an assistant designer to Poiret from the beginning of 1913 to the outbreak of war in 1914. His illustrations accompanied articles about Poiret fashion in *Harper's Bazaar* and reveal a signature Erté style that might not have developed without the inspiration of Poiret. He also launched the careers of Madeleine Panizon, a Martine student who became a milliner, and discovered shoemaker Andre Perugia, whom he helped establish in business after World War I.

### Poiret's Clientele

Not surprisingly, Poiret's clients were more than professional beauties, clotheshorses, or socialites. Besides the very top actresses of his time, Réjane and Sarah Bernhardt, the entertainer Josephine Baker, and the celebrated Liane de Pougy, one of the last of the grandes horizontales, there were: the Countess Grefulhe, muse of Marcel Proust, and Margot Asquith, wife of the English prime minister, who invited him to show his styles in London, creating a political furor for her (and her husband's) disloyalty to British designers. Nancy Cunard, ivory bracelet-clad icon of early twentieth-century style, recalled that she had been wearing a gold-panniered Poiret dress in 1922 at a ball where she was bored dancing with the Prince of Wales but thrilled to meet and chat with T. S. Eliot.

The international cosmetics entrepreneur Helena Rubinstein met Poiret while he was a young design assistant at Worth and followed him as he struck out on his own. She was photographed in one of his daring jupe-culottes in 1913 and wore a Poiret Egyptian style dress in her advertisements in 1924. The quintessentially French author Colette was a client. Boldini painted the Marchesa Casati in a chic swirl of Poiret and greyhounds. The American art patrons Peggy Guggenheim and Gertrude Whitney dressed in high bohemian Poiret and Natasha Hudnut Rambova, herself a designer and the exotic wife of the matinee idol Rudolf Valentino, went to Poiret for her trousseau.

### Postwar Poiret

Poiret was involved for the duration of the war as a military tailor, and although he occasionally made news with a design or article, when he was demobilized in 1919 he had to relaunch his fashion, decorating, and perfume businesses. His first collection after the war, shown in the summer of 1919, was enthusiastically received and fashion magazines like *Harper's Bazaar* continued to regularly feature his luxurious creations, typically made in vivid colors, lush-patterned fabrics, and trimmed lavishly with fur. Poiret's work perfectly suited the first part of the 1920s. The dominant silhouette was tubular, and fairly long, and most coats were cut on the full side with kimono or dolman sleeves. Such silhouettes were perfect for displaying the marvelous Poiret decorations, either Martine-inspired or borrowed from native clothing around the world. He continued to occasionally show such previous greatest hits as jupe-culottes and dresses with minaret tunics. In 1924 he left his grand quarters in the avenue d'Antin, moving to the Rond Point in 1925. He would leave that business in 1929.

### Obscurity

By 1925 Poiret had begun to sound like a curmudgeon, holding forth against chemise dresses, short skirts, flesh-colored hose, and thick ankles with the same kind of ranting tone once used by M. Worth to criticize Poiret's trouser skirt. Financially, he did poorly too, and he sold his business in 1929.

In 1931, *Women's Wear Daily* announced that Paul Poiret was reentering the couture, using as a business name his telephone number "Passy Ten Seventeen." Prevented from using his own name by a legal arrangement, he told the paper that he planned to print his photograph on his stationery, since presumably he still owned the rights to his face. This venture closed in 1932. After designing some for department stores such as Liberty in London in 1933, he turned his attention to an assortment of endeavors including writing (an autobiography called *King of Fashion*) and painting. He succumbed to Parkinson's disease on 28 April 1944.

While Gabrielle Chanel is credited with being the first woman to live the modern life of the twentieth cen-



tury (designing accordingly), it is Poiret who created the contemporary idea of a couturier as wide-reaching arbiter. His specific fashion contributions aside, Poiret was the first to make fashion front-page news; to collaborate with fine artists; develop lines of fragrances; expand into interior decoration; and to be known for his lavish lifestyle. Poignantly he was also the first to lose the rights to his own name.

Poiret's earliest styles were radically simple; these would give way to increasingly lavish "artistic" designs and showman-like behavior. By 1913 *Harper's Bazaar* was already looking back at his notable achievements: originating the narrow silhouette, starting the fashion for the uncorseted figure, doing away with the petticoat, being the first to show the jupe-culotte and the minaret tunic. That the fashion world was already nostalgic about his achievements proved oddly prescient: his ability to transform how women dressed would pass with World War I.

See also **Doucet, Jacques; Fashion Designer; Orientalism; Paris Fashion; Worth, Charles Frederick.**

#### BIBLIOGRAPHY

- Deslandres, Yvonne, with Dorothee Lalanne. *Poiret Paul Poiret 1879–1944*. New York: Rizzoli International, 1987.
- Poiret, Paul. *King of Fashion: The Autobiography of Paul Poiret*. Philadelphia and London: J. B. Lippincott, 1931.
- Remaury, Bruno, ed. *Dictionnaire de la Mode Au XXe Siecle*. Paris: Editions du Regard, 1994.
- Sweeney, James Johnson. "Poiret Inspiration for Artists, Designers, and Women." *Vogue*, 1 September 1971, 186–196.
- White, Palmer. *Poiret*. New York: Clarkson N. Potter Inc., 1973.

*Caroline Rennolds Milbank*

**POLITICS AND FASHION** Every large society and social group develops a system of social control or polity that is shared by the members of the group and relates in some way to their system of dress. The power to address diverse problems and needs of a society is invested in people who become specialists in delivery of the services of social control. Only those individuals so designated and recognized have the right to power and authority over group members. This system of control or government is reflected in the rules of the organization and evolves from the normative order and moral beliefs of the group. The moral ideas of a group both mold and reflect the group's beliefs concerning what is right or wrong behavior for members. Developing expectations for appearance, dress, and the extent to which one participates in fashion (defined here as the accepted way of behaving of the majority of individuals at a specific time and place) are social behaviors that are frequently subject to control by social organizations.

Control over dress and fashion participation is exercised both informally and formally through the political

structure of an organization and its power. The governing body serves several functions, including: (a) developing, delineating, and assessing rules and regulations so that the beliefs of the organization are molded by and reflected in them; (b) establishing a framework regarding the rights and responsibilities of members of the group; and (c) developing a process for applying and enforcing the rules for all members. A process for adding new regulations and a method to dispute existing regulations can be developed along with penalties and sanctions for violations of these rules. The court system in Western societies is an example of a process used to manage power in interpreting and applying regulations, which may prohibit members from participation in some activities as well as prescribe participation in others. Government also has power over relations with other societies in matters that involve group interests including mobilizing legitimate use of force to defend the group against infringement of others. Government also involves relationships with other societies in the form of trade agreements and regulations. For example, when foreign manufacturers can produce apparel products at a lower cost than domestic manufacturers, the domestic industries are threatened. Governments may make regulations to control the flow of foreign-produced products into domestic markets to force consumers to purchase domestic products and maintain domestic industries.

Another area related to dress where the government uses power is in developing regulations for consumer protection. Laws can be developed to protect consumers from unsafe or unhealthy apparel products as well as protect the environment from human exploitation. An example of the former are the laws that prohibit the use of flammable fabrics in apparel. An example of the latter are endangered species laws that prohibit the use of skin and furs of specific animals in apparel.

Examples of power conveyed through dress are common in all societies. Topics frequently addressed through formal and informal regulations include body exposure and gender differences. Societies have regulations concerning under what circumstances, if any, different aspects of both male and female bodies can appear uncovered or covered. The amount or type of skin exposed tends to be interpreted as symbolic of certain sexual behaviors. General societal efforts to control sexual behavior may include regulations regarding appearing naked in public, exposure of genitals, appearing in clothing associated with the opposite sex (cross-dressing), or the separation of the sexes (such as government-mandated separate swimming pools or even separate cash register lines for men and women). These regulations may be formal, as in the case of health laws concerning body exposure and food service (no shoes, no shirt, no service), or informal, as in the case of amount of body exposure on public beaches. Informal regulations often vary depending on the situation. For example, a brassiere and briefs worn by a female can offer as much if not more

body coverage than a swimsuit. However, a garment defined as a swimsuit is acceptable at locations like the beach or swimming pool, while a brassiere and briefs in the same place would be considered inappropriate.

Rules and regulations of social organizations vary in their degree of importance, in how they came into being, in the degree of emotional response that violating regulations might evoke, and the type of sanctions that might be applied to individuals who violate them. There are both positive and negative sanctions associated with engaging in or failing to participate in fashion. Positive sanctions such as praise or emulation reinforce behaviors perceived as correct. In contrast, a continuum in scope and intensity of negative sanctions can apply to individuals who fail to comply with the expectations of the group or group norms concerning dress and participation in fashion.

The type of negative sanction that results when individuals violate group norms for dress are tied to the degree of emotional response evoked. If the violation evoked a low degree of emotional response, concern is with violating a customary dress practice of the group. Violation of a customary practice generally does not create a great disturbance in the social organization of the group. If a sanction is applied by members of the group to influence the individual to change their behavior in keeping with the existing norm, the sanction may be in the form of gossip or teasing. In small organizations or societies where all members are known to each other, a negative sanction like gossip is probably all that is needed to force compliance with the expectations of group members. It is also possible that a mild sanction may result where a slight deviation from the group norm is tolerated if not accepted as only a minor deviation.

If the violation of the expectation for dress evokes a strong emotional response from group members, the violation is concerned with a moral standard of the group. Moral standards may be informally controlled, as is the case with customs concerning dress. Customs are associated with a history of practice, and violations may meet with negative sanctions from the group in the form of ridicule, avoidance, or ostracism. Moral standards concerning dress may also become codified into laws and formally controlled. Negative sanctions for violating laws concerning dress can include arrest, incarceration, or death.

Development of power through the rules of an organization or society do not guarantee that the rules equally reflect all members' interests. Whether the interests of men are favored over the interests of women was at issue in Terengganu, Malaysia, where the state government was said to have supported gender-based discrimination through dress codes as well as other practices. According to Endaya (2002), the government supported Islamic law as dress codes were developed that barred women from wearing bikinis and other clothing that exposed their bodies. Other dress codes that imposed



**Middle East politics and fashion merge, Beirut, 2002.** Saudi designer Yahya al-Bushairy debuts a dress featuring fake bloodstains, an Israeli tank, and the image of a young Palestinian boy killed by Israeli soldiers at the outbreak of the second Palestinian *intifada*. AP/WIDE WORLD PHOTOS. REPRODUCED WITH PERMISSION.

restrictions based on gender included a requirement for young Muslim women to cover their heads. Laws of this kind have become commonplace in the contemporary Islamic world. Another dress code exemplifying promotion of the interests of one group over another was a decree in 2002 made by King Mswati III of Swasiland, in southern Africa, who banned women from wearing trousers in the capital of Mbabane because the practice “violated the country’s traditions” (Familara 2002, p 4).

Few laws exist in the United States that regulate appearance, dress, or fashion in the workplace or in schools. However, dress codes are used to regulate appearances in the workplace as well as in schools, and judicial decisions (case laws) have developed concerning dress. In general, most courts uphold an employer’s right to set appearance standards through dress codes as long as the codes are related to a legitimate business interest, government interest, or for health and sanitation reasons (Rothstein et al,



**Political fashion by Gattinoni, fall-winter 2000–2001 collection, Milan, Italy.** A model displays a Gattinoni creation that criticizes the politics of right-wing Austrian politician Joerg Haider. AP/WIDE WORLD PHOTOS. REPRODUCED BY PERMISSION.

1994). As a result, few complaints brought forward by employees have been upheld in the courts unless the dress code differs between men and women, the code is demeaning, or is more costly to one sex versus the other (Lennon, Schultz, and Johnson 1999).

The courts have also held that students retain their constitutional rights when they enter the school building, although student conduct, including their appearance, can be regulated. Dress codes in schools are generally considered valid if they promote safety or if they prevent disruption or distraction of peers (Alexander and Alexander 1984). Since dress is a form of communication, students in the United States have voiced the complaint that some school dress codes violate their constitutional right to freedom of speech, which is guaranteed by the First Amendment (Lennon, Schultz, and Johnson 1999). Lewin (2003) reported on a student that was sent home from school for wearing a T-shirt with a picture of President Bush and the words “international terrorist.” The high school junior wore the T-shirt to express his antiwar sentiment and believed his right to express his political beliefs were violated when he was sent home from school. In this case, the school would have to prove that the stu-



### FREEDOM OF EXPRESSION IN DRESS

While the right to express a political opinion through dress may be protected by the constitution, customs concerning appropriate dress based upon gender may not be protected. In the United States, a reported case where clothing was disruptive of the learning process occurred when a young man was suspended from school for wearing a long peasant dress with a plunging neckline (Rabinovotz 1998). The issue was not only that the young man appeared in clothing customarily associated with young women, but that he stuffed tissue paper down the front. School officials noted that they did not want to create “a carnival-like atmosphere in the school” (p. B5).

dent’s T-shirt was so different and disruptive that it detracted from the educational process.

The classic case concerning dress codes and students’ freedom of speech in the United States is *Tinker vs. Des Moines Independent School District* (1969). The Tinker case involved a plan by students to wear black armbands to school to symbolize their opposition to the Vietnam War. Officials of the school learned of the students’ decision two days before it happened and implemented a special dress code banning armbands in school. The U.S. Supreme Court held that wearing armbands constituted a form of speech protected by the constitution. The court held that for student activity to be prohibited, school officials must reasonably forecast disruption in the school and must have some evidence to support their forecast. The courts also ruled that the predicted disruption must be substantial, and judged to be physical and damaging to the learning environment at school (Alexander and Alexander 1984).

Regulations of an organization, such as dress codes, can shape the dress of its members. Dress can also serve as a platform for protest against such regulations. In 2001, King Mswati III of Swaziland also revived an old law requiring girls to wear chastity belts with tassels. The belts, according to the king, would not only preserve a young girl’s virginity but also prevent HIV-AIDS. Subsequently, Swazi women protested and showed defiance against the law by dropping tassels in front of the royal palace (Familara 2002).

### Interpersonal Social Power and Dress

While the government of a society is involved in regulations concerning dress, customs concerning dress often



involve the use of dress as a symbol to communicate interpersonal social power. Interpersonal social power is defined as the potential to have social influence (French and Raven 1959). Social influence refers to a change in the behavior or belief of a person as a result of the action or presence of another person (Raven 1992). A typology originally developed by French and Raven and subsequently refined by Raven (1992; 1993) outlines six sources of social power that an influencing agent can draw upon to affect change in another person: legitimate power, reward power, coercion power, expert power, referent power, and the power of information. These sources of social power can be either formal or informal and can be communicated through dress.

Legitimate power is influence that is based on a social position or rank within the organization. This is power that is assigned to a position by the group to enforce the rules of the group (described previously as government). Symbolic of legitimate power is the uniform of an officer in the military or the robes of a judge. Reward power is influence derived from the ability to provide social approval or some form of compensation. Fashion editors and other arbiters of taste may exercise reward power as they name individuals to best-dressed lists or feature individuals repeatedly on the cover of magazines. A woman's beauty may also yield reward power as many men consider physical attractiveness in women to be highly desirable (Buss 1989). A woman's attractiveness may be rewarding to a man who is seen with her. Coercive power is reflective of influence that is achieved as a result of threats of punishment or rejection. Symbolic of coercive power is the uniform of a police officer because of their power to deter, detain, and arrest citizens. Expert power is influence stemming from knowledge or experience. Symbolic of this type of influence are the cap and gown of the academic or the lab coats of scientists and physicians. These individuals offer recommendations that are followed because individuals' believe in their expertise. Referent power is influence derived from the desire to identify with someone. Fashion models and movie stars wield referent power when individuals copy their dress. Information power is influence that is based on a logical presentation of information by the influencing agent, which persuades the individual to comply. Lennon (1999) noted that to Catholics the white clothing of the pope might represent informational power as a result of the belief that the pope has direct communication with God. Fashion is shaped by each of these types of social power.

As noted, legitimate power over fashion is in evidence when societies develop regulations concerning dress. Sumptuary laws have been used to maintain class and gender distinctions by disallowing certain individuals to wear certain styles or colors of clothing as well as requiring certain individuals to wear specific forms of dress. When the communist party came into power in China, coercive power became evident. According to

Scott (1958), communists developed a standardization of dress that made no distinction between the sexes or on the basis of rank. The military uniform of the communists consisted of a high-collared tunic, trousers with puttees, and Chinese shoes or rubber boots. After troops occupied the cities, the industrial workers adopted dress styled more or less identical to the military uniform except the color differed. Soon afterward, students, clerical workers, and manual workers adopted the party uniform. According to Scott, no one issued directives but citizens tacitly understood that clothes other than the uniform seemed unpatriotic, and those not adopting the new style were publicly reprimanded or lectured.

The effect of reward power on fashion becomes evident through the practice of naming certain highly visible individuals to "best dressed" lists. Other individuals emulate the appearance of those named to the list and fuel fashion change in terms of speeding the diffusion of a style as well as providing an impetus for change. The impact of expert power and information power on the direction of fashion comes from numerous fashion magazines sharing perspectives on what styles comprise the fashion of a time or place. From all the styles made available by designers and manufacturers, fashion editors select and feature those styles they believe will appeal to the readers of their publications. In this way, they wield their knowledge and expertise and hence attempt to shape fashion. Newspapers feature advice columnists who answer questions about what is appropriate dress for specific social events, and subsequently impact their readers about what styles are acceptable for a given time and place (and what is the current fashion).

See also **Dress Codes; Military Style; Religion and Dress.**

#### BIBLIOGRAPHY

- Alexander, K., and M. D. Alexander. *The Law of School, Students, and Teachers in a Nutshell*. St. Paul, Minn.: West Publishing Co., 1984.
- Buss, D. M. "Sex Differences in Human Mate Preferences: Evolutionary Hypotheses Tested in 37 Cultures." *Behavioral and Brain Sciences* 12 (1989): 1-49.
- French, J. R. P., and B. Raven. "The Bases of Social Power." In *Studies in Social Power*. Edited by D. Cartwright. Ann Arbor, Mich.: University of Michigan, 1958, pp. 150-167.
- Lennon, S. J. "Sex, Dress and Power in the Workplace: Star Trek, the Next Generation." In *Appearance and Power*, pp. 103-126. Edited by K. Johnson and S. Lennon. Oxford: Berg, 1999.
- Lennon, S. J., T. L. Schultz, and K. K. P. Johnson. "Forging Linkages Between Dress and the Law in the U.S., Part II: Dress Codes." *Clothing and Textiles Research Journal* 17, no. 3 (1999): 157-167.
- Lewin, T. "High School Tells Student to Remove Antiwar Shirt." *New York Times* (23 February 2003): A12.
- Raven, B. "A Power Interaction Model of Interpersonal Influence: French and Raven Thirty Years Later." *Journal of Social Behavior and Personality* 7 (1992): 217-244.

## POLO SHIRT

———. “The Bases of Power: Origins and Recent Developments.” *Journal of Social Issues* 49 (1993): 227–254.

Rothstein, M., C. B. Craver, E. P. Schroeder, E. W. Shoben, and L. S. Vandervelde. *Employment Law*. St. Paul, Minn.: West Publishing Company, 1994.

Scott, A. C. *Chinese Costume in Transition*. New York: Theatre Arts, 1958.

*Tinker v. Des Moines Independence Community School District*, 393 U.S. 503, 1969.

### Internet Resources

Endaya, I. “Malaysian Government Reinforces Gender Segregation.” *We* 19 (2002): 5. Available from <<http://straitstimes.asia1.com.sg/women/0,3320,00.html>>.

Familara, A. “Women Can’t Wear Trousers, Orders Swazi King.” *We* 20 (2002): 4. Available from <[http://news.bbc.co.uk/hi/english/world/africa/newsid\\_206000/2062320.stm](http://news.bbc.co.uk/hi/english/world/africa/newsid_206000/2062320.stm)>.

Kim K. P. Johnson

**POLO SHIRT** The polo shirt is a short-sleeved, open-necked white wool jersey pullover with turned-down collar, first worn by polo players from the United States and England. It is one of the first pieces of men’s bona fide sports apparel to filter into mainstream fashion at all levels of the market.

Like most sportswear, the polo shirt was functional in origin, designed to allow players greater freedom of movement on the polo pitch. Originally (that is, around 1900), the polo shirt was usually made from cashmere or, sometimes, from a mix of silk and wool; the cloth was designed to be close knit and absorbent. Although it was designed specifically for the rigors of polo, during the late 1920s the polo shirt was given a stamp of approval by the fashionable. It could be seen on the French Riviera as well as on the influential Palm Beach set, many of whom were wearing them on the tennis courts.

By the 1930s the all-white polo shirt had become a classic, and brightly colored polo shirts had become very popular as golf wear. It was not until 1933, however, that tennis star Rene Lacoste adapted and redesigned the classic polo shirt specially to be worn for playing golf and tennis. He is understood to have said at the time: “Pour moi, pour jouer au tennis comme au golf, j’eus un jour l’idée de créer une chemise.” (For myself, I had an idea one day to create a shirt for playing tennis as well as golf.) (Keers, p. 316). Lacoste’s white cotton pique shirt featured a green crocodile logo, both on account of his nickname, “Le Crocodile,” on the tennis court, and also as a trademark to help prevent imitations.

By 1935 the polo shirt was as popular off the sports fields as it was on them. A journalist sent to the Riviera pointed out: “Polo shirts have resulted in the oneness of the sexes and the equality of classes. Ties are gone. Personal touches, out. Individualism, abolished. Personality, extinct. The Riviera has produced a communism that would be the envy of the U.S.S.R.” (Schoeffler, p. 578).

This popularity endured, and the polo shirt became a cult shirt later taken on as a style essential by label-conscious football terrace casuals and customized by B-boys and Fly-girls during the late 1970s and 1980s, and often worn with Lyle and Scott or Pringle Knits. Meanwhile a version by Fred Perry was the polo shirt of choice by skinheads in the 1970s, the gay crowd during the 1980s, and more recently certain exponents of Britpop and skate (as freedom of movement is still key).

Although Lacoste was there first, Ralph Lauren has built an empire in part on his version of the polo shirt. The pique shirt with the iconic polo player logo was the shirt for the status-conscious consumer to own during the 1980s. Aimed at a more exclusive segment of the market, the Polo, was cut longer and narrower than the French version and continued as a cult classic among the more affluent, the label-conscious, and vintage experts alike.

See also **Jersey; Sport Shirt; Sportswear; T-Shirt**.

### BIBLIOGRAPHY

Amies, Hardy. *A, B, C of Men’s Fashion*. London: Cahill and Company, Ltd., 1964.

Byrde, Penelope. *The Male Image: Men’s Fashion in England 1300–1970*. London: B.T. Batsford, Ltd., 1979.

Chenoune, Farid. *A History of Men’s Fashion*. Paris: Flammarion, 1993.

De Marley, Diana. *Fashion for Men: An Illustrated History*. London: B.T. Batsford, Ltd., 1985.

Keers, Paul. *A Gentleman’s Wardrobe*. London: Weidenfeld and Nicolson, 1987.

Schoeffler, O. E., and William Gale. *Esquire’s Encyclopedia of 20th Century Fashions*. New York: McGraw-Hill, 1973.

Tom Greatrex

**POLYESTER** In 1929 Wallace Carothers, a researcher at DuPont, published an article describing his creation of polyester. DuPont obtained patents on this early form of polyester in 1931. Facing problems with this material, DuPont did not begin commercialization of it at that time, choosing instead to concentrate on the development of nylon. In the 1940s English researchers at Imperial Chemical Industries (ICI) developed the first practical version of polyester. It was made by combining ethylene glycol and terephthalic acid into polyethylene terephthalate (PET). DuPont bought the rights to PET in 1945 and began commercial production of Dacron polyester in 1953.

### Polyester Defined

The Federal Trade Commission defines polyester as “a manufactured fiber in which the fiber-forming substance is any long-chain synthetic polymer composed of at least 85 percent by weight of an ester

of a substituted aromatic carboxylic acid, including but not restricted to substituted terephthalic units,  $\text{p}(-\text{R}-\text{O}-\text{CO}-\text{C}_6\text{H}_4-\text{CO}-\text{O}-)_x$  and parasubstituted hydroxyl-benzoate units,  $\text{p}(-\text{R}-\text{O}-\text{CO}-\text{C}_6\text{H}_4-\text{O}-)_x$ " (Collier and Tortor, p. 179). The polyester most commonly used for fibers is PET.

### Properties of Polyester

To the average consumer, who is not a chemist, polyester is an extraordinary fiber with many desirable properties. Polyester is strong, both dry and wet. It is considered to be easy-care since it can be washed, dried quickly, and resists wrinkling. It holds up well in use because it has high resistance to stretching, shrinking, most chemicals, abrasion, mildew, and moths.

As with all fibers, polyester has some properties that are not desirable. While resistant to water-born stains, polyester is an oil scavenger. Due to its strength, polyester, particularly when cut into short staple lengths, does form pills (becomes rough with little balls). Polyester will burn with a strong odor and the molten residue can cause severe burns to the skin. Because polyester has low absorbency, it can become uncomfortable in hot weather. This problem has been addressed by making polyester fibers with multilobal cross sections (as opposed to round ones). Since the multilobal fibers cannot pack together as tightly as round ones, perspiration can be wicked (carried on the surface of the fibers) away from the body, thereby improving the wearer's comfort.

### Care of Polyester

Polyester is often blended with other fibers that require different care procedures. For this reason care procedures may vary across fabrics.

For 100 percent polyester fabrics, oily stains should be removed before washing. Generally they can be machine washed on a warm or cold setting using a gentle cycle. They can be tumble dried on a low setting and should be removed from the dryer as soon as the cycle is completed. Garments should immediately be either hung on hangers or folded. When handled in this way, fabrics made from 100 percent polyester rarely need ironing. If a touch-up is needed, it should be done at a moderate temperature on the wrong side of the fabric.

Some garments made from polyester or polyester blends may require dry cleaning. Tailored garments with multiple components, such as suits, may need to be dry-cleaned. It is important to follow care instructions and not assume that dry cleaning is better than washing. Pigment prints on polyester should not be dry cleaned, as the solvent would dissolve the adhesive that holds the pigment on the surface of the fabric.

### Uses of Polyester

Polyester could be called the tofu of manufactured fibers since its appearance takes on many forms. Depending upon the actual manufacturing process, polyester can resemble silk, cotton, linen, or wool. When blended with other fibers, polyester takes on even more forms, com-



### POLYESTER'S IMAGE

When polyester first reached the market in the 1950s, it was hailed as a wonder fiber. Travelers could wash a garment, hang it up, and have it ready to wear in a couple of hours. It needed no ironing.

By the late 1960s, polyester's image was very different. Polyester leisure suits for men and polyester double knit pantsuits for women were embraced by the middle-aged and elderly. College students, on the other hand, hated polyester. In the 1970s they even referred to it as the "P" curse. They perceived it as cheap and certainly not "with it."

To combat this image, the Tennessee Eastman Company launched a "polyester" campaign to revive its image. The Man-Made Fiber Producers Association, which became the Manufactured Fiber Producers Association—Polyester Fashion Council, launched its own campaign.

Both groups focused on polyester's easy-care properties instead of its cheapness. In 1984 the Man-Made Fiber Producer's Association and the Council of Fashion Designers endorsed collections made almost exclusively of polyester or polyester blends. Well-known designers, like Oscar de la Renta, Perry Ellis, Calvin Klein, and Mary McFadden, participated. Such publicity helped a little.

Probably a more important contributor to the improved image of polyester has been the technological advances made by the producers. High-tech fibers made of polyester have revolutionized the active sportswear market. Polyester microfibers are used to make fabric that feels like silk. Recycled PET polyester from soda bottles is transformed into comfortable fleece, thereby appealing to those concerned with the environment.



## POLYESTER FIBER, RECYCLED

binning the good qualities of each contributing fiber. Polyester is also the most-used manufactured fiber. The DuPont company estimates that the 17.7 million metric tons consumed worldwide in 1995 will rise to almost 40 million metric tons by 2005.

**Apparel uses of polyester.** Polyester is used for all kinds of apparel, by itself and in blends. It is found in every type of clothing, from loungewear to formal eveningwear. Some common blends include polyester and cotton for shirts and polyester, and wool for suits. Polyester contributes easy-care properties to both of those blends while cotton and wool provide comfort. Another use of polyester fiber is found inside some garments. A ski jacket with hollow polyester fibers used between the outer fabric and the lining provides warmth without weight.

**Home furnishings uses of polyester.** Polyester and polyester blends are used for curtains, draperies, upholstery, wall coverings, and carpets, as well as for bedding. Sheets and pillowcases made from polyester and cotton blends, do not need to be ironed, but they are not quite as comfortable as those made from 100 percent cotton. Carpets made from 100 percent polyester are less expensive than nylon, more apt to get packed down with wear, and allow considerable build-up of static electricity during the dry winter months.

**Other uses of polyester.** Polyester's low absorbency and high strength even when wet make it ideal for umbrellas, tents, and sleeping bags. Some industrial uses of polyester take advantage of the same characteristics. Hence, polyester is used for hoses, tire cords, belts, filter cloth, fishing nets, and ropes. Polyester is used for sewing thread, but thread made of 100 percent polyester tends to heat up and form knots when used in high-speed sewing. Cotton-covered polyester thread eliminates the problem.

See also **Microfibers; Recycled Textiles.**

### BIBLIOGRAPHY

Collier, B. J., and P. G. Tortora. *Understanding Textiles*. 6th ed. Upper Saddle River, N.J. Prentice-Hall, Inc., 2001.

Humphries, M. *Fabric Reference*. 3rd ed. Upper Saddle River, N.J.: Pearson Education, Inc., 2004.

### Internet Resource

*Polyester Revival*. 2004. Available from  
<<http://schwartz.eng.auburn.edu/polyester/revival.html>>.

Elizabeth D. Lowe

**POLYESTER FIBER, RECYCLED.** See **Recycled Textiles.**

**POLYETHYLENE.** See **Olefin Fibers.**

**POLYOLEFIN.** See **Olefin Fibers.**

**POLYPROPYLENE.** See **Olefin Fibers.**

**PRADA** Prada was founded in Milan in 1913 by Mario Prada as a luxury leather-goods firm, but it made little impact on the world of fashion until after Miuccia Prada took charge of her grandfather's company in 1978. Her first big success was a black nylon backpack with a triangular silver label. Soon her shoe and handbag designs became the focus of a veritable cult of fashionable consumers in Europe, America, and Japan. Miuccia Prada and her husband and business partner, Patrizio Bertelli, maintain close control over the company. They added a ready-to-wear line in 1989 and inaugurated the younger, slightly less expensive Miu Miu line in 1992, followed by Prada Sport, whose iconic red line is almost as recognized in certain circles as Nike's swoosh symbol. A string of shops and boutiques in Paris, New York, and San Francisco, designed in collaboration with the architect Rem Koolhaas, became



**Miuccia Prada, Milan, Italy, 1998.** Granddaughter of Prada's founder, Mario Prada, Miuccia took the Italian fashion design house to international heights of fame after taking over in 1978. AP/WIDE WORLD PHOTOS. REPRODUCED BY PERMISSION.

instantly famous. Prada also engaged in a series of complex ownership maneuvers in the late 1990s, buying and selling stakes in Gucci, Fendi, and other companies and forming a partnership with Azzedine Alaïa in 2000.

Prada clothes and accessories have been described as both classic and eccentric, frumpy but hip, marked by an ambiguous techno-retro sensibility. On the one hand, Prada's style is modern, drawing on northern Italian traditions of discreet elegance and fine craftsmanship. On the other hand, as Miuccia Prada said in 1995, "I make ugly clothes from ugly material. Simply bad taste. But they end up looking good anyway." She may have been referring to that season's "bad taste" collection, featuring such styles as a Formica check design, which evoked the look of 1970s polyester. Several years later she said, "I have always thought that Prada clothes looked kind of normal, but not quite normal. Maybe they have little twists that are disturbing, or something about them that's not quite acceptable. . . . Prada is not clothing for the bourgeoisie."

The eccentricity and intellectual purity of Miuccia Prada's clothes appeal to intellectuals and artists, while fashion editors are drawn to her constant experimentalism. Prada produced very strong collections in 2003 and 2004 that reaffirm her own aesthetic sensibilities and the stature of her company.

*See also* Alaïa, Azzedine; Fendi; Gucci; Handbags and Purses; Retro Styles; Shoes.

#### BIBLIOGRAPHY

Buxbaum, Gerda, ed. *Icons of Fashion: The Twentieth Century*. New York: Prestel, 1999.

*John S. Major*

**PRISON DRESS** Prison dress fluctuates historically and from country to country; from regimented "uniform" to the wearing of everyday clothes; and from work wear to nongendered jumpsuits as categorization of "criminality." Its implementation, design, and production varies according to current penal thinking, the degree of surveillance required by political regimes, types of crime committed, and according to the criminal institution—from young offenders' to women's prisons; from "top security" to local prisons or from federal to state penitentiaries.

In eighteenth-century America, Britain and Europe, regimes of "malign neglect" were prevalent, resulting in a disorder characterized by both men and women in rags, almost naked and the majority chained. Since crime was, and still is, for the most part, committed by the poor, privileges have been known to be exercised by inmates to procure their own clothing. Voltaire, arrested in France in 1727, demanded to wear his own clothes. In Ireland, in 1887, Home Rule dissenters were permitted to sup-

plement prison issue coarse woolen (frieze) garments with overcoats.

Prison reforms in America and Europe in the early nineteenth century, influenced by the Enlightenment and early "normalization" penal theories, saw prison dress as integral to the philosophy of discipline, as a tool in the "curing" of deviant behavior. In America between 1820 and 1930, quasi-military regimes of "silence" and solitary confinement saw the introduction of black-and-white striped all-in-one prison uniforms in order to demean and identify prisoners, and to increase the likelihood of recapture should they escape.

In Europe and specifically France, in the 1830s, the wearing of striped pants and blue linen overalls augmented surveillance of prisoners in chain gangs. In Australia, convict work gangs wore arrowed uniforms, while in Britain broad-arrowed, all-in-one prison uniforms were introduced in the 1870s Prison Act, as both a shaming and branding device. The arrows were not abolished until the 1920s in conjunction with post-World War I penal reforms.

In addition to uniforms, prisoners wore hoods when moving from "useful" work to cells or when exercising, reinforcing nineteenth-century debates focusing on the convicted criminals reflecting on their criminal activities in isolation and silence.

Continuing into the twenty-first century, it is evident globally that there is often a direct correlation between the degree of social control of prison regimes and the disregard for prisoners' human rights in the wearing of regulation clothing.

International Prison reforms of the 1950s culminated in a UN declaration in 1955, stating that:

Every prisoner who is not allowed to wear his own clothing shall be provided with an outfit of clothing suitable for the climate and adequate to keep him in good health. Such clothing should in no way be degrading or humiliating (Orland, p. 169).

Since the 1950s, variations in prison clothing have only approximated to the UN declaration and "normalization" debates that consider confinement, itself, to be punishment enough, while prison conditions should apply civilian standards in relation to food, clothing, and education facilities.

In the United Kingdom, unconvicted prisoners are allowed to wear their personal clothes and each prison sets its own system of privileges, one of which may be the wearing of civilian clothes. However, women in Holloway prison, given the choice, tend to wear prison issue maroon or gray tracksuits, white T-shirts, and trainers, either to preserve their own clothes or to identify with their "total institution" selves as a survival mechanism. Convicted male prisoners are issued jeans, sweatshirts, blue-and-white-striped shirts, green work overalls and unbranded trainers. On arrival, they are often offered



**Penitentiary workers.** Prisoners of the Mississippi State Penitentiary walk to work on cotton fields in 1939. Black and white striped uniforms were designed to humiliate the prisoners as well as make them easy to spot should they escape. AP/WIDE WORLD PHOTOS. REPRODUCED BY PERMISSION.

clothes rejected by other prisoners, which as a result are demeaning in their lack of fit.

In the United States prison clothing is determined by type of institution and category of crime committed. In federal prisons white jumpsuits are worn inside the prison, while orange outfits are worn in transit. Women prisoners are allowed to wear their own clothes after 5 P.M. In both state and federal prisons some categories of prisoners are able to wear their own clothes or prison-issue jeans, T-shirts, branded trainers and loose prison-issue overalls as work wear. In Immigration Detention orange loose-fitting jumpsuits are issued to both men and women, which some women find demeaning because it is against their cultural norms to wear pants.

Both British and American prison dress is produced in prison workshops by inmates under strict controls as to design, regarding seam allowances, lack of pockets, sizing, fabric, and color.

Internationally, prison dress varies in relation to a country's penal policies, wealth, or prisoner categorization system. The degree to which prisoners are allowed to wear their own clothes at times demarcates "normalization" as rehabilitation, foreseeing the return of the prisoner to "normal" life after release, as in Sweden and Holland's 1997–1998 "model" prison systems, Switzerland's "open prisons," and Lithuania's 1997 "own clothes" policy, which was hailed by penal reformers as a victory for prisoners' rights. The issue of not wearing prison dress has been central to protests by political prisoners campaigning for the right to separate political status from convicted criminals, as in Irish prisoners' "blanket protests," 1976–1982, and in Peru, 1985–1989. In other circumstances the wearing of civilian clothing reflects a return to regimes of "malign neglect," as in Haiti's unsegregated men, women, and juveniles' prison in Port-au-Prince in the late 1990s.



Recent penal debates include the advantages and disadvantages of electronic tagging and, although not strictly a prison-dress issue, it raises concerns, as Foucault indicated, about the “recoding of existence” within prison walls, commensurate with social control or the rehabilitation of prisoners through the regulation of dress and identity.

See also **Dress Codes; Uniforms, Occupational.**

#### BIBLIOGRAPHY

- Foucault, Michel. *Discipline and Punish: The Birth of the Prison*. London and New York: Penguin Books, 1991.
- Goffman, Erving. *Asylums*. London: Penguin Books, 1968.
- Mayhew, Henry, and John Binny. *Criminal Prisons of London*. London: Frank Cass and Company, Ltd., 1971.
- Morris, Norval, and David Rothman, eds. *Oxford History of the Prison*. Oxford and New York: Oxford University Press, 1995.
- Orland, Leonard. *Prisons: Houses of Darkness*. New York: Free Press; London: Macmillan, 1978.

Juliet Ash

**PROFESSIONAL ASSOCIATIONS** The fashion and clothing industries are notable for their interdependence, their sharing of information, and their support of each other within their specific areas. Their professional associations may be divided roughly into two categories: membership organizations with either individual or corporate members, and trade organizations whose purpose is to further the goals and enhance the image of a particular segment of the industry.

The oldest and most prestigious of the individual member organizations is the Fashion Group, founded in 1931. Its catalyst was *Vogue's* editor-in-chief, Edna Woolman Chase, who, at the urging of one of her staff, gathered a small group of women who held positions of consequence in the fashion industry and related fields. Aiming to draw membership from several areas, they formed an advisory board consisting of: Dorothy Shaver, first woman to become president of a major department store, Lord and Taylor; Mrs. Stanley Resor, executive of the advertising agency J. Walter Thompson; Mrs. Ogden Reid of the *New York Herald Tribune* publishing family; and Mrs. Franklin D. Roosevelt, wife of the then governor of New York State, who, because of her labor activism, represented her interest in the garment industry and the International Ladies Garment Workers Union (ILGWU). Other early founding members eager to join this first nonprofit group were the cosmetic stars Elizabeth Arden and Helena Rubinstein, the designer Claire McCardell, the *Harper's Bazaar* editor Carmel Snow and as regional chapters opened, Edith Head in Los Angeles. They defined their mission as a forum in which to exchange information and a force to support women in their emerging role in a male-dominated industry. In the early

2000s, men were invited to membership, but it remained primarily a woman's group. It serves 6,000 members of the fashion communities of every major U.S. city and internationally from Paris to Tokyo, over 40 in all; and now known as FGI (Fashion Group International). The same goals still remain—sharing information by covering the seasonal trends from Europe and America and enhancing women's careers by providing informational seminars and networking opportunities. FGI also maintains an archive of its history, documents, and fashion images dating from 1931.

Women in the beauty, cosmetics, fragrance, and related industries created an organization in 1954 called Cosmetic Executive Women (CEW). Based in New York, it has associated organizations in France and the United Kingdom. At its founding, it was a social organization, remaining relatively small until 1975 when its mission was expanded to promote the contributions of women in the industry; in 1985 it again expanded to include education, philanthropy, and industry development. The establishment in 1993 of the CEW Foundation provided a philanthropic arm to fund charities dedicated to helping women better their lives.

Dominant on the international scene is the venerable *Chambre Syndicale de la Couture Parisienne*. Behind the rich and elaborate pageantry of Paris haute couture is the organization that sets the rules and regulations for fashion's most exclusive and expensive enterprise. The *Chambre* is the iron hand in fashion's velvet glove.

Established over a century ago, this governing force dictates which houses may distinguish themselves with the appellation “haute couture,” which means high sewing or high fashion. There is a demanding regimen involved in becoming one of these privileged few. The *Chambre's* rules state that a design house meet these requirements: a house must employ at least twenty employees in its atelier; present a collection of at least seventy-five designs twice a year, and show them at least forty-five times annually in a special area of the house.

Headed by a president and a director of public relations, the *Chambre* organizes the calendar and venues for the biannual showings, provides public relations support, and requires that videos and portions of the collections are shown in New York, Tokyo, and the Middle East.

A house's jewel in the crown, haute couture is profitable only through licensees and fragrances, for example, but is the foundation for influence and prestige crucial to a designer's image. It is the laboratory for new ideas, the research and development of the fashion industry. The *Chambre Syndicale*, through its exacting standards, perpetuates the authority of these fashion laboratories.

Few of the organizations of the other fashion capitals are regarded with the same respect. Rather, they were created to function as their organizing, marketing, and public relations entities, involved with designer collection shows as well as trade shows, identified by titles such as

Collezione Milano and the London Fashion Council. But all serve an important purpose—the vital support of an international economic force and its creative energies.

American designers are invited to join the Council of Fashion Designers of America (CFDA), an organization founded in the 1960s by the publicist Eleanor Lambert and others, when they saw that most American designers were toiling in the back rooms, unrecognized; few had their names on their garments' labels and even fewer on the showroom's front door. The American fashion industry and its design talent were not achieving the recognition and publicity it deserved.

The Council achieved its mission of gaining worldwide credibility for the industry. In the early 2000s, its membership is made up of both apparel and accessory designers. Its most famous contributions to the industry have been "7th on Sixth," organizing the seasonal showings and relocating them from individual venues to tents in New York's Bryant Park, and their fund-raising efforts on behalf of AIDS. Seventh on Sixth has been acquired by the talent agency IMG and continues as a separate entity; the CFDA continues its original mission, the support for and recognition of American design talent, granting scholarships and presenting its annual awards, which have become the "Oscars" of the fashion industry.

See also **Fashion Advertising; Fashion Editors; Fashion Industry.**

#### BIBLIOGRAPHY

- CEW, Cosmetic Executive Women Website. 2004. Available from <<http://cew.org>>.
- Council of Fashion Designers of America. Website. 2004. Available from <[www.cfda.com.flash.html](http://www.cfda.com.flash.html)>.
- Fashion Group International. Website. 2004. Available from <[www.fgi.org/home.html](http://www.fgi.org/home.html)>.
- International Association of Clothing Designers. Website. 2004. Available from <[www.iacde.com](http://www.iacde.com)>.
- UNITE! Website. 2004. Available from <[www.uniteunion.org](http://www.uniteunion.org)>.

*Lenore Benson*

**PROTECTIVE CLOTHING** Clothing has been used for protection since the beginning of time, shielding the human body from physical, social, emotional, and spiritual threats, real and imagined. Today, the term, *protective clothing* is generally used to denote apparel and apparel accessories that focus on *physical* protection for the body.

Protective clothing may be as simple as a sun hat or as complex as a space suit. Defined broadly, it may include items that have not traditionally been thought of as clothing, such as flotation vests or football helmets. Watkins uses the term *portable environment* to describe protective clothing, defining it as "a unique environment that is carried everywhere with an individual, creating its own room within a room and its own climate within the larger climate of our surroundings" (1995, p. xv).

The array of physical threats from which clothing provides protection today is endless. Most people use clothing to protect themselves from cold, heat, rain, snow, sun, and other aspects of day-to-day weather. But protective clothing also allows the body to exist in hazardous environments such as the deep sea or outer space. It is worn to protect individuals from many different hazards in war zones or in the workplace—from falling debris to toxic chemicals to bullets to insect bites. It provides protection for sports and leisure activities as diverse as hockey, cycling, and skiing. Many individuals with injuries or handicaps use protective clothing to prevent further body damage or to substitute for loss of body functions.

The concept of protection has had many connotations for various cultures in different eras. There is evidence to suggest that the bodies of early peoples acclimated to extremes of heat and cold without the use of clothing and that the earliest garments were *not* worn for what we might now consider to be physical protection. Instead, it is believed that the first garment was a girdle worn around the hips to protect the genital region from magic (Renbourn and Rees 1972, p. 228). While some might consider these girdles to be merely a form of spiritual protection, their wearers surely believed that it kept them from physical harm. Throughout history, even the most sophisticated forms of physically protective clothing have had to meet the social, emotional, and spiritual needs of those who wore them, or they were rejected, regardless of the protection they offered.

#### Weather and War

Prior to the twentieth century, protective clothing generally served one of two functions: as shelter from climatic conditions or as protective armor. The materials used to make clothing a shelter were as varied as the regions in which people lived and the natural resources found in them. For the earliest protective garments, leaves were worn in the tropics and animal furs were used in more frigid climates. Garments used for shelter from the weather were greatly influenced by the fashions of the times. Social mores, societal beliefs, and traditions may have had even more influence on their design than the actual climatic conditions from which they were purported to provide protection.

To a certain extent, the same was true of the design of protective armor. The European suits of armor and the elaborate costumes of the Japanese samurai warrior both carried with them significant symbolic meaning. However, armor evolved through the ages in large part as a response to the evolution of weapons.

The first known armor, worn by the Egyptians in 1,500 B.C.E., consisted of an unwieldy shirt-like garment to which overlapping bronze plates were sewn. In the eighth century B.C.E., the Greeks made improvements on this garment by shaping metal plates to each body part. With the development of chain mail by the Celts in the third century B.C.E., a warrior's ability to function in bat-

tle was significantly improved. Mail was lighter than earlier armor and flexed with every body movement. Since it provided protection from arrows and knives and other weapons of the times, chain mail remained as the primary protective material used in battle for many centuries.

When crossbows were developed, chain mail could no longer provide sufficient protection. Full suits of metal armor, with overlapping metal plates sewn to a flexible leather backing, came into use at the end of the thirteenth century. A full suit of armor was considerably more effective against the weapons of the times and actually provided better mobility than the early Egyptian plated shirts since the metal was shaped and distributed more evenly over the whole body.

With the development of gunpowder and firearms, metal suits of armor became a thing of the past. Soldiers in World War I and gangsters in the 1920s continued to wear garments to which metal plates were attached. Metal and ceramic coverings provided protection for airmen during World War II, but these were much too heavy for the ground soldier. It took advanced-technology developments in the mid-twentieth century to lead designers to truly suitable responses to firearms. In the mid-1960s, when Kevlar aramid fibers were patented and made into fabrics, it finally became possible to design relatively thin, lightweight, flexible shields for bullets and explosive fragments. These designs made it possible for armor to function covertly as well. Thus, the new soft armor could be used not only in battle, but also by police and undercover professionals.

### The Technological Boom

The whole concept of protective clothing expanded exponentially during the second half of the twentieth century. The explosion of technological advances during this time made possible forms of protective clothing that had previously existed only in the minds of writers of science fiction. As in the case of armor, new hazards inspired new protective clothing designs. And new designs often changed the behavior of their wearers.

For example, early firefighters stood at a distance from flames wearing their everyday clothing while throwing buckets of water on burning structures. Even in larger cities during the eighteenth and nineteenth centuries, where water was pumped through hoses, no real physical protection was provided by the ornate uniforms issued, and thus firefighters moved no closer to the fire. The rubber jackets and, later, the cotton duck bunker coats that were worn in the first half of the twentieth century kept firefighters dry and warm in the constant spray of water from hoses, but also moved them no closer to the fire.

Flame and high-heat resistant aramid fibers such as Nomex and Kevlar developed in the 1960s combined with portable breathing devices to allow firefighters to actually enter burning buildings. Aluminizing the surface of



**Bio-safety level 4 hazmat suits.** Two people wear hazardous materials (hazmat) protection suits, capable of protecting a human being from the most dangerous biological pathogens. Special gas masks filter out airborne germ particles. AP/WIDE WORLD PHOTOS. REPRODUCED BY PERMISSION.

these materials in fully enclosed ensembles called *proximity suits* made it possible for firefighters to move still closer to the flames. Further developments in protective materials resulted in *entry suits*, in which firefighters could actually walk into the flames.

Thus, there is a cycle in the evolution of protective clothing that is much like one in the medical world. As organisms develop a resistance to medicines designed to defeat them, they venture forward and new medicines need to be developed. As protective clothing removes each threat, individuals venture further into danger and require newer, more powerful forms of protection.

### Protection from Multiple Hazards

While some items of protective clothing are designed to protect from only one hazard, many others must solve multiple problems. A list of the modern battle-ready soldier's requirements for protection illustrates the complexity of multiple physical threats. Military documents point to a daunting list of hazards from which clothing must provide protection: climate (heat, cold, rain, solar radiation, wind, sand, snow); weapons (ballistics, chemical, biological, flame, blast, nuclear flash, directed energy such as microwaves); detection (visual, infrared); mechanical (cuts, abrasions, crushing); sensory (damage to hearing, sight); and biting insects and animals.

The great dilemma in designing for protection from multiple hazards is that there rarely is a clear-cut hierarchy of threats. Designing always involves trade-offs. For example, to protect soldiers from chemical weapons, they



must be fully isolated from the environment. This necessitates the provision of breathing air and a method of preventing heat build-up within protective clothing. However, the motors used to circulate air leave a signal that can be picked up by infrared detection devices, providing the enemy with a target. Since both heat exhaustion and exposure to chemical agents could be fatal, neither of these requirements can simply be ignored to satisfy the need for full camouflage. Multifunction protective clothing for outer space, deep-sea diving, chemical-spill cleanup, Arctic exploration, asbestos removal, bomb disposal, race-car driving, mountain-climbing expeditions, and many other activities and environments all involve protection from multiple hazards. Even clothing that has only one primary protective function involves challenging trade-offs between protection, mobility, thermal comfort, and use of the senses.

### Litigation

The accelerated pace of technological development in the latter part of the twentieth century, combined with changes in society's attitudes toward lawsuits, had a significant affect on the development of protective clothing. For centuries, many people had worked and played in hazardous conditions without physical protection. As technology made it increasingly possible to be protected from a wide array of hazards, many companies and organizations began to face lawsuits for not designing protective clothing properly or providing it when needed.

Improvements in sports equipment added another legal problem: The more fully equipment protected athletes, the more willing they were to take serious risks on the playing field and to use the equipment itself as a weapon. The litigation arising from serious football injuries in the 1960s spurred the formation of a number of regulatory groups to oversee the design and use of protective sports equipment. In 1978, the National Collegiate Athletic Association (NCAA) mandated that every football player in an NCAA game must wear a helmet that was certified to have met specific performance standards. In 1980, similar regulations were set for high school players.

Interest in consumer protection surged during this time as well, with the most notable development for protection in everyday clothing being the Flammable Fabrics Act: Children's Sleepwear, enacted in 1972.

The Occupational Safety and Health Administration (OSHA), formed in 1971, formalized government involvement in regulations to ensure health and safety in the workplace. Many places of work, even those in which protective clothing had never been worn, then became a target for litigation. Providing the wrong protective clothing was as risky as providing none at all. The resulting potential for financial liability spurred many companies to seek protection for their workers and led toward the development and refinement of many new protective

materials and designs. As women began to enter more professions, equipment specifically geared toward a woman's size, shape, and specific protective needs also began to be developed.

### Active Protection

Many future developments in protective clothing lie in the arena of active protection; that is, garments which interact with or change the environment of the wearer rather than passively insulating the body from it. High-tech materials and developments in the field of wearable computers make active rather than passive protection the wave of the future.

By the early twenty-first century, loggers wore pants that incorporated fibers that pull out of a protective fabric to clog the chains of a chain saw, stopping it immediately, should the saw accidentally drop onto the logger's leg. Epileptics wear vests that read muscle contractions and automatically inflate personal airbags around the head when a seizure is about to occur.

The U.S. Army envisions that full-body hard suits will one day "walk" injured or unconscious soldiers back to safety. Fabrics of the future may be self-cleaning, fibers rippling to move unwanted dirt away or emitting an agent to neutralize a toxin. Braddock and O'Mahoney describe a future garment as being "made of small cellular units connected to one another by screws" (1998, p. 141). These cells and screws would be directed by a computer link that could order minute automatic adjustments in the shape of any part of the garment or direct heat, cooling, massage, or medicines through tiny channels to isolated body areas when needed. The protective possibilities for future active clothing designs are endless.

See also **Aprons; Coat; Fashion, Health, and Disease; Space Suit.**

### BIBLIOGRAPHY

- Braddock, Sarah E., and Marie O'Mahoney. *TechnoTextiles: Revolutionary Fabrics for Fashion and Design*. New York: Thames and Hudson, Inc., 1998.
- Hatch, Kathryn L. *Textile Science*. Minneapolis: West Publishing Company, 1993.
- Renbourn, E.T., and W. H. Rees. *Materials and Clothing in Health and Disease*. London: H.K. Lewis and Company, 1972.
- Watkins, Susan M. *Clothing: The Portable Environment*. Ames, Iowa: The Iowa State University Press, 1995.

Susan M. Watkins

**PROUST, MARCEL** Marcel Proust (1871–1922) is the author of the sixteen-volume *À la recherche du temps perdu* (known in English as *Remembrance of Things Past* [1922–1931]). The first volume was published in 1913, and the last after the writer's death. These novels reveal not only Proust's expert knowledge of dress—he researched

very precise details of garment construction—but also the way in which his appreciation of fashion has far wider implications, both within his work and beyond.

### Proust the Dandy

When Jacques-Émile Blanche completed his portrait of the young writer Proust in 1892, he captured on canvas Proust's image of himself, which has become our own. Possibly, he was first thought of as a dandy, a socialite, and a darling of the duchesses—moving between the different worlds of *fin-de-siècle* Paris with infinite ease—and last as a novelist. He was, in fact, born to wealthy middle-class parents. His father, a Catholic, was a surgeon, and his Jewish mother was the daughter of a stockbroker. Proust's entrée into society and his literary career began when he was still a schoolboy. At the Lycée Condorcet (1891–1893), his friends included the children of literary and artistic families, who invited him into their world and their salons; he and his friends edited and published two literary magazines.

By 1906, when Proust began to devote all his energies to his masterwork—after his legal studies at the École libre des Sciences-Politiques, a prestigious school which formed part of the Sorbonne, and the publication of various juvenilia, pastiches, gossip columns, and translations—he was less inclined to haunt the salons. He had been keenly affected by the “Dreyfus affair”: In 1897 a Jewish army officer, Captain Alfred Dreyfus, was accused and convicted of passing government secrets to the Germans and was sentenced to deportation to Devil's Island. The controversy played out over the course of a decade, until a court of appeals exonerated Dreyfus and he was pardoned. As a Jew and a man of conscience, Proust was active and passionate in his defense of Dreyfus, while most of his former grand hostesses sided with the government and army. The deaths of both Proust's parents soon afterward and the increasing problems caused by his ill health strengthened his belief that he was wasting his time.

By 1913 his appearance had changed so radically that a young visitor to his flat, who glimpsed the Blanche portrait, did not recognize the slender young man pictured with a gray cravat and an orchid in his buttonhole. But that young man, who had gone to Cabourg, the “Balbec” of the novels, “armed with Liberty ties in all shades,” as he wrote to a friend in 1894 (Painter, p. 174) had not entirely disappeared. The huge coat that Proust always wore in later years was lined with fur, and he was never without a hat, gloves, and a cane.

### Proust and His Circle

Proust's socializing began in the artistic salons of the late 1880s, but his desire to scale the heights of the Faubourg Saint-Germain—the wealthy and aristocratic section of Paris—to meet duchesses as well as the *grandes cocottes* (“great courtesans”) of the Belle Époque was strong and speedily gratified. The models for his later characters were found in these different settings. The character



**Marcel Proust, 1932.** While generally not linked to the world of clothing design but rather to literature, Proust's writings reveal his intense interest in fashion. AP/WIDE WORLD PHOTOS. REPRODUCED BY PERMISSION.

Baron de Charlus, for example, was based on Robert de Montesquieu, aristocrat and would-be poet, whom Proust first met in 1893. In the portrait of Montesquieu by the society painter Giovanni Boldini, the baron is raising his ebony cane like a rapier; the blue porcelain handle matches his large cuff links. His long-waisted jacket with wide lapels edged with broad ribbon and his white shirt with high, soft collar and dark cravat are part of the recognizable dress code of the *fin-de-siècle* dandy. His unusually high-coiffed hair, handlebar moustache, and small imperial-style beard, along with his arresting and extraordinary pose, created the kind of extreme image that Proust feared most, given its perceived links to homosexuality and to the writer Oscar Wilde, whom Proust had met and whose trial for homosexual conduct was thoroughly covered in the French press. Yet the young Proust himself was photographed with two close friends in a similar, though muted, mode of self-presentation.

Elisabeth, Comtesse Greffulhe, one of the models for Duchesse de Guermantes, was a friend and cousin of Montesquieu. She posed for an unknown photographer at about the same time as Montesquieu sat for Boldini. She stands arranging flowers in a tall Greek vase, showing off the unusual back detailing of her dress, with its

large white collar appliquéd with flowers and its pattern of light-colored flowers flowing down the dark dress, spreading out and underlining the shape of the skirt. Comtesse de Chevné, another model for the duchess, wore cornflowers in her hat to emphasize her bright blue eyes, just like the Duchesse de Guermantes in the novel. She chose to be depicted, by another unknown photographer, in far more somber attire, as if to emphasize her intellectual credentials. This yoking of art and high society, which so fascinated Proust, caused André Gide, as a young publisher, to reject the first volume of the novel. In his later years Proust did not forgo the company of artists nor did he eschew high society completely. He became friendly with the writer Jean Cocteau and dined with the ballet producer Sergey Diaghilev and the dancer Vaslav Nijinsky, but his work took priority.

### Fashion within the Novels

We are told, toward the end of *Swann's Way*, that the young narrator is glad of his Charvet tie and patent boots as he waits for the former courtesan Odette de Crécy in the Bois de Boulogne. She is now married to the rich and respectable Charles Swann. Earlier in the volume she has been described as one of the most stylish women in Paris, with “rich garb such as no other woman wore.” Her toilettes are always depicted in great detail, and the narrator is fascinated by the Japanese-style gowns that she wears at home. She has an inordinate number in different fabrics—silk, crepe de chine, chiffon—and the colors vary from old rose and mauve to Tiepolo pink and gold, all described carefully and frequently in *Within a Budding Grove*. An intense focus on sensuous detail is one way in which dress operates within the novel's sequence.

Fashion is also vital as the way in which an individual constructs his or her personal identity while remaining mindful of the rules of social caste. Odette's outdoor clothes show small details in their trimmings or patterns, which hark back to her heyday as Second Empire courtesan. The craftsmanship and the overall design of her garments are stressed. The narrator follows Odette, enchanted, through the Bois de Boulogne, and Proust records the details of the linings of her jackets and the collars of her blouses, likening them to Gothic carvings. Such details may never be noticed by a casual observer but they are nevertheless vital.

The woman to whom Proust awards the accolade of the very best-dressed woman in Paris is also one of the most socially elevated—Oriane, Duchesse de Guermantes, who is always spectacular and distinctive in her toilette. In *The Guermantes Way*, the narrator tells us of her appearance at the opera with a single egret feather in her hair and a white spangled dress, designed to make her companion and cousin, the Princess, seem overdressed. It is she, as well as Odette, to whom the narrator turns in *The Captive* when he wants help with the selection of clothes for his mistress, Albertine. Indeed, it is Oriane's Fortuny gowns that Albertine is seen to covet.

Male elegance, too, is described—particularly that of Swann, whose leather-lined hat, in *Within a Budding Grove*, the Duchess of Guermantes notes, just as Swann comments on the tiny coral balls frosted with diamonds that she wears in her hair at the soirée described toward the end of *Swann's Way*, likening them to rose hips dusted with ice. Dress, fabric, texture, and detail are seen as vital factors in the evocation of memory so germane to the novel. In the very last pages the narrator speaks of discerning the different threads woven together in a fabric of which he can now perceive the overall design.

### Proust's Legacy

Although other writers have been fascinated by fashion, Proust is among the first to mention designers by name and to award them equal stature with painters and composers. Perhaps no author before him described an outfit, jewels, or accessories in such careful, minute detail. More significant, perhaps, is his *roman-à-clef* technique; celebrities are thinly disguised and their valorization permeates his work. In the twenty-first century's celebrity-dominated culture, this seems peculiarly pertinent.

See also **Art and Fashion; Canes and Walking Sticks; Dandyism; Fashion and Homosexuality; Liberty & Co.; Social Class and Clothing; Wilde, Oscar.**

### BIBLIOGRAPHY

- Adams, William Howard. *A Proust Souvenir*. New York: Vendome Press, 1984.
- Balsani, Leo. *Marcel Proust: The Fictions of Life and Art*. New York: Oxford University Press, 1965.
- Bowie, Malcolm. *Proust among the Stars*. New York: Columbia University Press, 1998.
- Carter, William C. *Marcel Proust: A Life*. New Haven, Conn.: Yale University Press, 2000.
- Painter, George D. *Marcel Proust: A Biography*. New York: Random House, 1989.
- Pringue, Gabriel-Louis. *Trente ans de dîners en ville*. Paris: Revue Adam, 1948.
- Steele, Valerie. *Paris Fashion: A Cultural History*. Rev. ed. New York: Berg, 1998.
- White, Edmund. *Marcel Proust*. London: Viking, 1999.

*Pamela Church Gibson*

**PSYCHEDELIC FASHION** Psychedelia—the range of sensations, epiphanies, and hallucinations induced by chemical stimulants—was an epochal cultural phenomenon of the 1960s; in retrospect, it seems not only a key component of the decade's sensibility, but an apt symbol of the 1960s reordering of social, political, and artistic structures. It was inevitable that fashion and psychedelic experience would go hand-in-hand since one of the effects of an LSD (lysergic acid diethylamide) “trip” was a heightened appreciation of color, texture, and line. Psychedelic fashion did more than evoke or pay tribute to



the mind-alerting experience; it became a way to enhance participation. Given that the LSD—popularly called acid—experience involved erasing discreet boundaries, it was appropriate to dress in clothes that enhanced the ability of the communicant to merge into an experience that for many became nearly sacerdotal rite.

### The Big Bang

Partaking of LSD was central to the hippie credo, and the outlandish clothes of the hippies disseminated the psychedelic sensibility. Flowing shapes seemed to relate to the unbinding of restrictions unloosed by the hallucinogenic experience. The prevalence of tactile fabrics in hippie fashions spoke to the sense-enhancing properties of the acid trip. Most visible were its innovations in palette and imagery: equally provocative vibrating patterns and colors. Certain traditional motifs—the amoebalike crawl of Indian paisley, for example—were appropriated as psychedelic imagery. The accoutrements included face painting in Day-glo neon colors that recreated the incandescence of acid chimeras. But the principal topos of psychedelic fashion were portraits of light as it was fractured, made mobile by the lens of the acid trip. The awakened kineticism of light made flat surfaces seem to churn and roil. Colors bled, emulsified, and merged kaleidoscopically.

LSD existed for thirty years before reaching the widespread cultural acceptance and curiosity it aroused during the 1960s. Similarly, slightly before the apogee of psychedelic fashion in the mid to late 1960s, fashion inspired by the oscillatory geometries of op art deployed a pleasurable hoodwinking of perceptual faculties. Psychedelic experience and psychedelic fashion's incongruous reshuffling of identifiable reference points recalled surrealist art and Dada, which also were the progenitors to some extent of pop art. Pop art functioned in the 1960s as its own sometimes surreal rebuke to nonrepresentational abstract expressionism.

### The Total Environment

Psychedelic fashion became a way for external reality to seemingly be transformed by the visions projected on the mind's internal screen. Psychedelic fashions existed within a cultural context that encompassed the radical lifestyles of the hippies, the transcendent "acid" experience as well as constructed environments that sought to simulate the acid experience. These encompassed communal affirmations such as the "be-in," and performance art "happenings." Psychedelic fashion became an indispensable component of the total environment created in discotheques or rock palaces; it allowed an integration of the reformed environment and the remade self. The *dereglement de tous les sens* that Artur Rimbaud had once propounded, was heightened orally by the fuzz box and "wah-wah" pedal distortions. Light shows at the rock concerts and at the discotheque hurled pulsating apparitions

at the spectator. The blinking strobe light atomized the continuity, the gestalt of visual perception. It might be said that under the strobe light, all fashion became psychedelic.

Psychedelic fashion was a quintessential 1960s movement. Although it was eventually, and to some degree opportunistically, embraced by virtually every mainstream design and sector of the fashion industry, it would be hard to isolate a single designer or even a cluster of designers who could be credited for its invention or promotion. Nevertheless, the psychedelic preoccupation with light and the total environment reached a paradigm at the Manhattan boutique Paraphernalia in 1966, when electrical engineer Diana Dew devised a vinyl dress that turned-on at the command of the wearer. A miniaturized potentiometer fit on the belt of the dress and regulated the frequency of the blinking hearts or stars, which could be coordinated to the throbbing beat of the disco soundtrack. That same year, Yves Saint Laurent brought psychedelic light and color to pop art's disembodied trademarks with a bridal gown that flashed an incandescent flower, which enlivened the runway show's traditional finale.

Psychedelic sensibility was essential to the second phase of 1960s' fashion vocabulary, the move away from some of the sleeker and brusquer characteristics of mod fashion. It was consanguineous with the second phase's absorption of folk and tribal lexicon, the experimentation in role playing and persona construction made possible by the improvised costumes adopted by youth cultures and spilling out into the Western world's clothes-wearing population at large. The unprecedented outfits certainly owed something to the phantasmagoria of acid visions. Tribal and psychedelic converged with mottled patterns of African and Indonesian fabrics, the phosphorescent splotches and showers of tie-dye.

Psychedelic fashion was a grass-roots groundswell, a radically demotic movement that eventually generated a ubiquitous acknowledgment. In New York, for example, one could buy made-to-order tie-dye ensembles at both The Fur Balloon on West 4th Street in Greenwich Village and at Halston's salon on East 68th Street on the Upper East Side.

### Cycles of renewal

Ultimately, the lexicon and the fashion became degraded. New adjectives introduced into colloquial language and the language of fashion, "psychedelic" and "trippy" among them, no longer retained their original referents but became generic adjectives of approval. Psychedelia not only offered the keys to the cosmos but became the latest marketing ploy. "Call it psychedelic and it will sell fast, some merchants say," was a page-one headline on *The Wall Street Journal* in 1968. Psychedelic fashion petered out in the early 1970s, partly from overkill and overexposure, and partly from the changing zeitgeist. Yet it remained popular with students until enjoying a full-scale

revival in the mid-1980s, and has continued as a recurring motif.

See also **Art and Fashion; Paisley; Saint Laurent, Yves; Subcultures.**

#### BIBLIOGRAPHY

- Lobenthal, Joel. *Radical Rags: Fashions of the Sixties*. New York: Abbeville Press, 1990.
- Masters, Robert E. L., and Jean Houston. *Psychedelic Art*. New York: Grove Press, 1968.

*Joel Lobenthal*

**PUCCI, EMILIO** Emilio Pucci, the *marchese di Barsento a Cavallo*, was born in Naples on 20 November 1914. The scion of an illustrious family tracing its heritage to the thirteenth century, Pucci grew up in the Palazzo Pucci on the *via dei Pucci* in Florence.

#### Education and Early Career

Reared within a strict aristocratic environment, Pucci turned out to be a rebel both personally and professionally. He graduated from the Università di Firenze in 1941 with a doctorate in political science, after having attended the University of Georgia in Athens, Georgia, and Reed College in Portland, Oregon. His decision to study in the United States, however, introduced him to the American way of life.

Proficiency in skiing started Pucci's fashion career. He had been a member of the Italian Olympic skiing team in 1934 and had gone to Reed College on a skiing scholarship in 1937. In 1947 the photographer Toni Frissell took photographs of Pucci and his female companions in Zermatt, Switzerland, wearing form-fitting, colorful, but practical ski clothes that Pucci had designed. These photographs were shown to the head buyer for Lord and Taylor, Marjorie Griswold, and the fashion editor of *Harper's Bazaar*, the legendary Diana Vreeland. The pictures were published in the December 1948 issue of *Bazaar*, while several Pucci models were ordered for Lord and Taylor's New York store. This order was Pucci's first retail success in the United States.

Pucci, however, needed additional financial security after World War II. In 1949 he opened a boutique in Capri, Italy, where he sold the tapered pants that became known as Capri pants, as well as sexy silk shirts fitted to show off the female figure. With the return of peace, people were again traveling for pleasure. Pucci astutely surmised that his boutique, which he named Emilio of Capri, and his casual, colorful resort fashions would be popular with the new visitors. International sophisticates like Consuelo Crespi, Mona Harrison von Bismarck, and Maxime de la Falaise were frequent customers at Emilio of Capri. Diana Vreeland praised Pucci as "divinely Italian" (Kennedy, p. 57). Although it was extremely unusual

at that time for an aristocrat to be a shop owner and designer or dressmaker, Pucci enjoyed the creative process.

#### Post-World War II Innovations

The next phase of Pucci's career began at the first fashion show of Italian designers, which was organized by Giovanni Battista Giorgini in 1951 and held in the *Sala Bianca* at the Palazzo Pitti in Florence. Other designers who presented their work at the show included Simonetta, the Fontana sisters, Alberto Fabiani, and Emilio Schuberth. Major American stores like Neiman Marcus and Saks Fifth Avenue sent their buyers, who brought Italian, postwar, ready-to-wear fashion back across the Atlantic. Pucci's sleek, lightweight T-shirts, jersey dresses, silk shirts, and tapered pants made for an exciting new style.

Once the original and somewhat daring look of Pucci's designs appeared in the top U.S. stores, he was on the way to celebrity-designer status. Pucci won the coveted Neiman Marcus Award in 1954. He won the award a second time in 1967. Marcus, the head of the Dallas-based store, said, "Postwar fashion was hungry for a color explosion and [Pucci's] exotic, vivid color combinations were timed to perfection" (Kennedy, p. 67). Marjorie Griswold, Pucci's major retail supporter, had already suggested that he sign his name in script within the print design because the motifs themselves could be copied. Hence, the authenticity of a Pucci garment can be verified when the signature "Emilio" is visible throughout the print. Pucci used his first name rather than his family name because it was considered shocking for a member of the Italian nobility to work as a dressmaker or tradesman instead of a diplomat or politician. He said, "I am the first member of my family to work in a thousand years" (Kennedy, p. 42).

Pucci introduced a very lightweight, wrinkle-free, silk jersey that could be rolled up and packed easily—a feature appreciated by growing numbers of jet-set travelers. Technically advanced fabrics allowed him to fashion nonrestrictive clothes that were modern yet glamorous. Pucci also introduced an exciting array of colors, boldly mixing espresso and azure, tangerine and fuchsia, lime and turquoise, plum, and many other shades.

In addition to designing sleek silhouettes that allowed easy movement, using packable fabrics in an abundance of joyful colors, and insisting on top-quality workmanship, Pucci also designed his own prints. His prints included swirls, filigrees, arabesques, geometric figures, and kaleidoscopic or mosaic patterns. They were inspired by his far-flung travels to North and South America, Bali, Africa, the Middle East, Australia, and Asia. Pucci's finely-engineered prints also represented rich aspects of Italian history and cultural events as well as Mediterranean land- and seascapes. His prints from the 1950s, for example, featured motifs from Renaissance art, Florentine landmarks, the sunscapes and flowers of



**Italian designer Emilio Pucci at a Berlin fashion show, 1972.** Pucci stands on the runway with the models that presented his exotic silk and chiffon gowns. Bold, wild patterns adorn the sleek sheath dresses, reflecting Pucci's rebellious spirit. CHARISSA CRAIG, MODEL. REPRODUCED BY PERMISSION.

Capri, the mosaics of the Duomo di Monreale in Sicily, nightlife in Naples, and the flags from the famous annual Palio race in Siena. From the 1960s to the 1980s, his prints were inspired by his travels to Cuba, Bali, India, Hong Kong, and Tanzania. The American space program, underwater explorations, pop art, op art, rock music, and psychedelia also influenced his designs. One of Pucci's most famous prints, called Vivara, was inspired by the island Ischia; it became the name of his first fragrance in 1965. He even found time to sketch ideas for new print patterns during plane trips or sessions of the Italian Parliament, where he served from 1963 to 1972.

#### Designer Accessories

Emilio Pucci became one of the first designers with a recognizable high-status label and signature style. He was a leading pioneer of diversification and paved the way to widespread fashion licensing. He designed various products from perfumes to accessories, including handbags,

scarves, sunglasses, tights, shoes, and lingerie—the last made by the American company Formfit Rogers. In 1977 Pucci even designed the interior of an automobile for a special edition of the Lincoln Continental Mark IV.

Pucci personally supervised the design of all his products. He designed colorful, sexy, and futuristic uniforms for the flight hostesses of Braniff Airways in 1965 and Qantas Airways in 1974. He also found time to design uniforms for the policewomen of Florence and clothes for Barbie dolls. Pucci took special pleasure in designing the mission patch for the Apollo 15 space mission in 1971.

Pucci married Christina Nannini and had two children, Laudomia and Alessandro. The family's elegant palazzo lifestyle was chronicled in fashion magazines. The "Prince of Prints" became as famous as the women who wore his designs—a list that included Marilyn Monroe (who was buried in a green Pucci dress), Elizabeth



Taylor, Audrey Hepburn, Sophia Loren, Gina Lollobrigida, Lauren Bacall, Jacqueline Kennedy, Grace Kelly, Barbara (“Babe”) Paley, Gloria Guinness, Barbara Walters, Gloria Steinem, and many others. Helen Gurley Brown, the author and former editor of *Cosmopolitan*, said, “The dresses were spare, sexy, and liberating!” (Kennedy, p. 8). Not to be outdone by fashionable women, men also wore wild and colorful Pucci ties, bowties, jackets, and beach attire.

### The Pucci Revival

The wave of enthusiasm for Pucci’s clothes known as “Puccimania” reached its height in 1967. Pucci’s dresses became less popular in the 1970s as fashion trends changed, but the early 1990s saw a resurgence of interest in current Pucci styles and a blossoming market for vintage fashion—especially Puccis from the 1960s. Pucci collectors of the early 2000s included Madonna, Jennifer Lopez, Nicole Kidman, Julia Roberts, Paloma Picasso, and Ivana Trump. Vintage Puccis were sold in specialty shops and at auction for as much as \$500 in 2002, whereas as a Pucci silk jersey dress from Saks Fifth Avenue in New York had been priced at \$150 to \$200 in the mid-1960s. When Pucci died on 29 November 1992, the fashion editor Carrie Donovan wrote in the *New York Times*, “He personified a moment, rather a long one in history” (1 December 1992).

After Pucci’s death, his company continued under the guidance of his daughter, Laudomia, and wife, Cristina. The rich archive of fabrics maintained in the Palazzo Pucci provided an ongoing source of fashions for the Pucci boutiques. As creative director, Laudomia Pucci hired talented designers to continue her father’s concepts. In February 2000 LVMH, the French luxury goods conglomerate headed by Bernard Arnault, purchased 67 percent of the Emilio Pucci SRL company, with the Pucci family retaining the rest of the business. More Pucci boutiques were opened around the world, from Bangkok to Palm Beach.

Christian Lacroix, the contemporary French designer known for his fantastical, exuberant, and exotically colorful fashions, became artistic director of the Emilio Pucci collection in April 2002. He said in the December 2002 issue of *Vogue*, “Emilio Pucci’s vision is still very modern.... It’s a way of life” (p. 76).

*See also* **Brands and Labels; Fontana Sisters; Italian Fashion; Lacroix, Christian; Perfume; Ski Clothing; Vintage Fashion.**

### BIBLIOGRAPHY

- Biennale di Firenze. *Looking at Fashion, Emilio Pucci*. Milan: Skira Editore, 1996.
- Collins, Amy Fine. “Pucci’s Jet-Set Revolution.” *Vanity Fair* (October 2000): 380–393.
- Kennedy, Shirley. *Pucci: A Renaissance in Fashion*. New York: Abbeville Press, 1991.

- Tally, Andre Leon. “Style Fax.” *Vogue* (December 2002): 76.
- Vergani, Guido. *The Sala Bianca: The Birth of Italian Fashion*. Milan: Electa, 1992.

*Shirley Kennedy*

**PTFE.** *See* **Techno-Textiles.**

**PUNK** Punk as dress cannot be discussed without at least some reference to its musical underpinnings. It has to be recognized that within the field of cultural studies, it both energized and produced a series of new responses to the theoretical construction of youth culture. Thus, it can be regarded as a formative movement in both its sartorial and visual presentation, and the consequent analysis of it as a subcultural style. It can be further argued that punk culture stands at a pivotal point in the relationship between youth cultural style and its commodification.

### The United States

Punk had its roots in inner city America at the beginning of the 1970s. While its inspiration could be traced farther back, as a movement with a set of cohesive identities, New York appears to be its birthplace. But as befits its urban nature, punk cannot be said to have a singular geographic location. Detroit, Cleveland, and possibly Los Angeles are other sites that could also claim an emergent aesthetic and style identified as punk.

One of the many effects of the post-World War II consumer boom within the United States and Europe was an ever-expanding market for goods, particularly within a youth cultural market that led to an active struggle from young people to shape and realize their own identities through the consumption of music and fashion. This popularization of “youth” as “style” and “surface” was in part reflected in the breakdown of distinctions between high and low culture within the pop art movements—of Britain’s Independent Group and its U.S. equivalent—of the 1950s and 1960s. In the latter grouping was Andy Warhol and the Factory. Symptomatic of pop, Warhol’s work, its repetitive nature, and its insistence in articulating nothing more than the surface engaged with a youth cultural perspective of nihilism that revolved around the adage of “live fast, die young.” As such, alongside Warhol’s desire to surround himself with a coterie of the young, dangerous, and beautiful, the seeds of an avant-garde music scene began to be established.

Set around Warhol’s Factory and the Lower East Side in a time of political and financial meltdown in New York, the music of these artists, in particular the Velvet Underground, reflected the repetitiveness and surface of the Factory’s output. Playing at seedy venues such as Max’s Kansas City, CBGBs, and Mother’s, the music of the Stooges, New York Dolls, MC5’s, Wayne County, and Patti Smith took their influences from a variety of sources



**Punk fashion, 1983.** Standing around in London's Brockwell Park, punks show off wild hairstyles and metal-studded black leather clothing, typical of the later punk fashion. While earlier years saw various other styles within the movement, it was this look that became the iconic punk image. © RICHARD OLIVIER/CORBIS. REPRODUCED BY PERMISSION.

all intent in demolishing what was seen as the pompous, sterile sound of contemporary music in the guise of “progressive” and “stadium” rock. So a disillusionment with all things commercial and the be-suited executives at the record companies led to a desire to perform music that would shock people to their senses, bringing music back to the poverty/richness of the everyday. While this was going on in the United States, Britain was in the grip of glam rock, a pub rock sound characterized in part by the clothing of its performers that looked to the transgressive in their stage presence. Of these perhaps the most original was David Bowie. Under a string of different pseudonyms and increasingly bizarre record personalities, David Bowie proved influential in his effect on both music and clothing in Britain and the United States.

By 1975 the American “punk scene” had evolved into a subculture characterized by the music of Television, and perhaps most famously The Ramones who wore clothes that reflected their rent boy street personas. Given that many of the musicians had gravitated from a bohemian inner-city scene detailed in the writings of William Burroughs and Alexander Trocchi, it seemed like a natural continuation of this aesthetic. The black

leather jacket, T-shirt, straight jeans, and sneakers of the hustler proved the initial look of an American underground scene. While there were those such as the New York Dolls, who followed an English glam rock look of androgyny—made up with leather and knee-length boots, chest hair, and bleach—the majority pursued an understated street look. It was this musical explosion within the United States that brought a youngish Malcolm McLaren over to the United States to manage the New York Dolls where he fell into the punk scene and made clear his intentions to ship it back to the United Kingdom.

### The United Kingdom

While it is obvious that Malcolm McLaren and his partner, Vivienne Westwood, are central to any definition of punk, especially in relation to its clothing, it is also clear that the self-aggrandizing machine which is Malcolm McLaren has skewed any historical understanding. In part this is justified, as McLaren and Westwood's string of shops on the Kings Road defined a particular look and McLaren's desire to exploit punk as a scene in the United Kingdom led directly to his management and dressing of the Sex Pistols, the most notorious of all punk bands.

Starting out on the Kings Road in 1972 as *Let It Rock* a shop that catered to a late working-class Teddy Boy revival, drape coats, and brothel creepers, Vivienne Westwood and Malcolm McLaren's shop then moved through a number of reincarnations, including *Too Fast to Live* and the fetish-orientated *Sex*, and later *Seditionaries*, and finally *World's End*. As in the United States, McLaren encouraged those who railed against society to hang around the shop. His and Westwood's antiestablishment aesthetic soon earned them a place in the London underground scene. However, we are not talking of the sophistication of New York, but a more rag-tag army of disillusioned teenagers. And it is from this group that the Sex Pistols were formed. Apart from the "rock" posturing of Glen Matlock, the rest of the band—Johnny Rotten, Sid Vicious, Steve Jones, and Paul Cook—were wholly working class and outside any artistic or intellectual clique. While many of the other emerging punk bands had members from an art school background, the *Sex Pistols* could claim to be the genuine thing: an authentic working-class group of kids celebrating the boredom of their socially proscribed position.

### Theoretical Angles

It is this notion of authenticity and working class that, in part, has always demarcated a British and U.S. understanding of punk as a philosophy or cultural experience. Whereas in the United Kingdom youth counter cultures had generally been a central experience of working-class youth—an expression of dissent and isolation from their parents and a reaction against a dominant ideology that on the surface worked to repress their ambition, in the United States the readings had not taken on such class-bound strictures.

The result in the United Kingdom was the publication in 1977, the peak of punk in Britain, of Dick Hebdige's *Subculture: The Meaning of Style*. Using punk as its central example, Hebdige employed a series of methodologies from Marxism to Structuralism and Semiotics to chart a view of post-World War II British youth cultures that were constructed through their working-class credentials and a desire to react against the dominant powers that appeared to shape their lives. In this analysis, Hebdige applied the notion of "bricolage" as the stylistic combination of disparate coded objects to juxtapose and create fresh meaning to punk dress and style. The safety pin's original meaning as something to hold together a diaper and to prevent injury to the child was pierced through a nose or stuck onto ripped jeans and jackets. Its once certain assigned meaning through was contextually redefined through its wearing as a stylistic device.

### Clothing

In Britain the spectacular nature of punk as a style surpassed that of the United States. Westwood's designs—from "Destroy" T-shirts, bum bags, tartan bondage

trousers, safety-pinned and ripped muslin shirts, and sloganed clothing—were a visible affront to a population who, for the most part, regarded long hair on a man as a concern. While youth cultures had previously been vilified within the national press for violence and drug taking, punk directly challenged the dress aesthetic and morals of a conservative nation. Beyond the Kings Road in 1976, 1977, and 1978, the influence of McLaren and Westwood diminished rapidly. Though they may have attracted a contingent of followers in London and their home counties, punk was a nationwide phenomenon and as such developed a style that was perhaps more coherent and less showy than Westwood's ready-to-wear clothing.

This do-it-yourself (D.I.Y.) aesthetic consisted of Hebdige's "bricolage" as the throwing together of a series of looks based around a few staple elements, such as mohair sweaters, tight jeans, and "jelly shoes." There was also the widespread use of secondhand clothing from charity shops and rummage sales—suits with T-shirts and basketball boots, collarless granddad shirts, and peroxidized hair—with or without the ubiquitous stenciling and letter art of favorite bands, anarchist slogans, or the Situationist politicizing of groups such as The Clash.

This aesthetic was perhaps more subdued than the Kings Road look, but is more representative of punk as a dress code within the United Kingdom both for individuals and bands such as The Buzzcocks, The Damned, The Adverts, 999, and out on a style limb The Undertones. By 1977 punk's popularity as a musical form had seen by then the infamous Grundy television interviews; the Sex Pistols single "God Save the Queen" reaching number one in the week of the Queen's Golden Jubilee; and the interest of record companies in signing up groups who claimed in any manner, shape, or form to espouse a punk belief.

### Commercialization

By 1979 the first stage of punk in the United Kingdom was coming to an end. Its commercial status became assured, from advertisements in music papers such as *NME* and *Sounds* advertising punk clothing, badges, and T-shirts to the record companies' desires to promote a gentler, more public-friendly "new wave" and to the release of various compilations that promised to tell the whole punk story. However, punk itself as both a music and a style attempted to change in order to avoid its co-option/commercialization by hardcore bands such as The Exploited and political bands such as Crass. In terms of dress, there was a re-engagement with the motorcycle jacket, the use of Dr. Martin work-wear boots, and the introduction of a wide variety of commercial rainbow hair colorants, along with the ubiquitous Mohawk haircut, which, along with a penchant for black, crossed over into both Goth and the New Romantic movements of the early 1980s. It is this look that for many years characterized, and as such became the iconic image of, punk.



As a direct result of the energy of punk and the diffusion of a whole series of offshoots from punk with fanzines such as *Punk* in the United States and *Sniffin' Glue* in Britain, it became clear that there was a market for hard-edged youth journalism, which dealt specifically with an urban street scene. Punk fostered the emergence in 1980 of street-style magazines such as *The Face*, *iD*, and *Blitz*. Yet, as a consequence of these magazines trying to locate and expose scenes bubbling up from the streets, it became increasingly difficult for "subcultural" movements to resist commercialization through exposure. And it is this that is perhaps punk's greatest legacy to youth cultural style. While it would be inaccurate to suggest that youth cultures prior to punk were left to get on without the prying eyes of parents and large commercial operations intent on supplying, if not co-opting, youth culture toward their own ends, it is clear that punk stood at the crossroads of a contemporary "lifestyle" aesthetic. That youth culture in the early 2000s is so heavily mediated and prey to the intense gaze of commercial pressures is perhaps one of the less-appreciated consequences of punk as an historical event.

From the sounds of Seattle and grunge, through to a swathe of bands in 2004 that look more like The Ramones than The Ramones, punk has endured. For the fashion industry, its stylistic conceptualization as both "bricolage" and "rebellion" makes it the perfect vehicle to reappropriate the old in the spirit of the new, which gives rise to the interpretation of punk as a seasonal look on a cyclical basis. As such, its legacy is assured within both its musical and stylistic qualities. Yet whether its politics of change or its celebration of the bored and nihilistic attitude of teenagers can ever be faithfully played out again is another question.

*See also* **Fashion and Identity; Subcultures; Teenage Fashions; T-Shirt.**

#### BIBLIOGRAPHY

- Anscombe, Isabelle. *Not Another Punk Book*. London: Aurum Press, 1978.
- Colegrave, Stephen, and Chris Sullivan. *Punk*. New York: Thunder's Mouth Press, 2001.
- Coon, Caroline. *1988: The New Wave Punk Rock Explosion*. London: Orbach and Chambers Ltd, 1977.
- Hebdige, Dick. *Subculture: The Meaning of Style*. London: Methuen, 1979.
- Heylin, Clinton. *From the Velvets to the Voidoids: A Pre-Punk History for a Post-Punk World*. New York: Penguin USA, 1993.
- Laing, David, and Milton Keynes. *One Chord Wonders: Power and Meaning in Punk Rock*. Philadelphia: Open University Press, 1985.
- Makos, Christopher. *White Trash*. London: Stonehill Publishing, 1977.
- McNeil, Legs and Gillian McCain. *Please Kill Me: The Uncensored Oral History of Punk*. New York: Penguin USA, 1996.
- Perry, Mark. *Sniffin' Glue: The Essential Punk Accessory*. London: Sanctuary Publishing, 2000.
- Sabin, Roger, ed. *Punk Rock: So What?* London and New York: Routledge, 1999.
- Savage, Jon. *England's Dreaming: Sex Pistols and Punk Rock*. London: Faber, 1991.

*Frank Cartledge*

**PURIM COSTUME.** *See* **Halloween Costume.**



**QIPAO** The *qipao* is a Chinese dress for women. The style is also called *cheongsam* in Cantonese, and this term has come to be the more widely used one in English, though spelled in several different ways. The defining features of the dress are a fitted silhouette, a high collar, and side skirt slits. In its classic form, there is a front flap overlapping to the right, which fastens along the collarbone, under the arm, and down the right side. The details are subject to changing fashions within the limits of the basic form. It can be sleeveless, or have sleeves of any length. The hemline varies, but usually reaches somewhere between the knee and the ankle. The *qipao* can be made of almost any fabric, although it is mostly associated with silk. The dress material can have a printed or woven repeat pattern across its surface or, if the material is plain, a favorite way of tailoring the style is for the front panel of the dress to be pre-embroidered with a sweeping floral or dragon design, leaving the back of the garment unadorned. The entire dress is often edged in one or more strips of narrow binding, which is sometimes in plain-colored bias-cut satin, or else of lace or patterned ribbon. Although press-stud and zip fastenings are used, traditional knot buttons made from fabric are popular. These can be extravagantly shaped and are specially made to suit the pattern or color of the chosen dress material. To be a genuine *qipao*, the dress needs to be custom-made. Purchasing off the rack is not considered correct form.

#### **Origins and development.**

The *qipao* can be elegant rather than flashy. Although one of its hallmarks is a good fit, it does not need to fit tightly. In the first half of the twentieth century, there is no doubt that the *qipao* provided a cross-section of Chinese women with a style of dress, and consequently a mode of deportment and way of moving, that suited their increasingly public lives. But, bound up with the charges of decadence leveled at the dress, it became enmeshed in questions concerning nationalism. At the height of the style's popularity, China, having overthrown imperial rule in 1911, was trying to forge itself into a modern nation-state. For some, certain traits of the *qipao* were perceived as western and therefore tainted, especially when worn with high-heeled shoes and bobbed hair. For many others, however, the *qipao* seemed both modern and Chinese, and Song Meiling (1897–2003), the wife of the Chi-

nese Nationalist leader Chiang Kai-shek (1888–1975), was rarely seen in any other style and used it to good effect to rally supporters to her husband's cause.

#### **Survival**

After 1949, the *qipao* survived outside China among overseas Chinese, in Hong Kong, a British colony until 1997, and also in Taiwan, where Chiang Kai-shek set up an opposing government after being defeated by Mao. However, in these places too, by the 1960s, a younger generation of women came to view the *qipao* as old-fashioned and adopted a more international style of dressing. Older women still favored it as formal wear and in Hong Kong, a big tourist destination, it became associated with the service industries as a type of uniform. With the loosening up of the strictures after the death of Mao, all kinds of dress regimes became possible in greater China and the *qipao* was just one of several styles that was revived and also re-worked by Chinese fashion designers. Hong Kong's return to the People's Republic of China heightened the profile of the dress and some saw it as a patriotic garment. *Qipao* are increasingly worn by students of Chinese origin at graduation ceremonies both in East Asia and in the United States. Weddings in Chinese communities across the globe provide arenas for lavish spending and the *qipao* has become an accepted part of the marriage ritual. Western women, too, have eagerly taken up the dress and it continues to provide inspiration for Euro-American couture designers.

*See also* **China, History of Dress; Orientalism.**

#### **BIBLIOGRAPHY**

- Roberts, Claire, ed. *Evolution and Revolution: Chinese Dress, 1700s–1900s*. Sydney: Powerhouse Publishing, 1997.
- Steele, Valerie, and John S. Major, eds. *China Chic: East Meets West*. Yale and London: Yale University Press, 1999.

*Verity Wilson*

**QUANT, MARY** Mary Quant was born in London on 11 February 1934. A self-taught designer, she cut up bedspreads to make clothes when she was only six; as a teenager, she restyled and shortened her gingham school dresses.



**Mary Quant showing off her Order of the British Empire award.** The self-taught Quant was the recipient of several awards for her innovative, progressive fashion designs. © BETTMAN/CORBIS. REPRODUCED BY PERMISSION.

She recalled admiring the appearance of a child at a tap-dancing class who wore a black “skinny” sweater, pleated skirt, and pantyhose with white ankle socks and black patent shoes (Quant: 1966, p. 16). From the mid-1950s she transformed styles like these into amusing and sexy clothes for young women, and paved the way for London to become a center of irreverent youth-oriented fashion.

Quant’s parents would not accept her attending a school of fashion design, but compromised by allowing her to go to art school. She met Alexander Plunkett Greene while she was studying illustration at Goldsmith’s College of the University of London. Plunkett Greene later became her business partner and husband. After leaving art school, Quant was apprenticed to Erik of Brook Street, a Danish milliner working in London. In 1955 Quant’s husband purchased Markham House in London’s King’s Road to start a shop named *Bazaar*, and open a restaurant called Alexander’s in the basement. Mary was responsible for buying the stock for *Bazaar*, Alexander for sales and marketing, while Archie McNair, an ex-solicitor who ran a photography business, handled the legal and commercial side of the business. Quant designed a black five-petaled daisy logo during this period; it eventually became her worldwide trademark.

Quant sourced innovative jewelry from art students and bought clothes from various wholesalers to stock the boutique. One of the items designed for *Bazaar*’s opening was a pair of “mad” house-pajamas, which were featured in *Harper’s Bazaar* and purchased by an American manufacturer to copy. Encouraged by her success as well as dissatisfied with the styles on the market, Quant decided to design her own stock. After attending a few evening classes on cutting, she adjusted some Butterick patterns to achieve the look she wanted. Quant was designing for Butterick by 1964; some of her pattern designs sold over 70,000 copies. Each day’s sales at *Bazaar* paid for the cloth made up that evening into the next day’s stock. As business took off, Quant employed a dressmaker to help her, and then another, and another, and so on.

Quant brought a groundbreaking approach to fashion retailing by providing an informal shopping experience. In contrast to traditional fashion retail outlets, which ranged from high-class couturiers through staid town-center department stores and chain stores such as C and A Modes to High Street dress shops, *Bazaar* set out to make shopping for clothes enjoyable: loud music played, wine flowed, and the boutique stayed open until late in the evening. Most importantly, the stock was constantly replenished with new and highly desirable designs. “The clothes were very simple. Basically tunic dresses, and very easy to wear, unlike the couturier clothes which were very structured. And put together with other things—tights and knickers in ginger and prune and a grapey colour, that people weren’t used to” (Harris, 1994). Quant persuaded theatrical costume manufacturers to make the tights she sold, as there were no pantyhose in the color that Quant required on the market.



While Quant's prices were reasonable in comparison to those of the traditional fashion houses, her clothes were made to a high standard—many were silk-lined—and were not cheap.

Quant was probably the first designer to acknowledge the influence of youth subcultures, and she credits the Mods as an important source of inspiration. Mods were a sub-cultural youth group characterized by their immaculate dress—their 'sharp' tailoring and love of Italian sportswear, and the parka coat that they wore to protect their clothes whilst traveling by scooter. One of her most successful early designs was a white plastic collar to be added to a sweater or dress. One of Quant's trademark innovations was the mini skirt: by 1960 her hemlines were above the knee and crept up the leg to reach thigh level by the mid-1960s. She also derived inspiration from school uniforms and menswear, especially traditional country clothes—knickerbockers, Norfolk jackets, "granddaddy" tab-collared shirts, Liberty bodices or combinations (one-piece garments), and traditional children's underwear. Quant undertook much of her research at London's Victoria and Albert Museum. She bought her fabrics, notably Prince of Wales checks and herringbone weaves, from Harrod's, and persuaded knitwear manufacturers to make their men's cardigans 25 centimeters longer so that they could be worn as dresses. Whereas fashion designers had traditionally looked to Paris for stylistic guidance, Quant and her husband watched youth programs on television and attended fashionable London nightspots to identify new trends.

One example of Quant's work from 1956/57 was a dress in black-and-white checked wool cut in a sleeveless balloon style and teamed with a skinny-rib black sweater. For the winter of 1957/58 Quant designed an ensemble comprised of a rust-red Norfolk-style jacket, Harris tweed knickerbockers—she favored knickerbockers—and a pinafore dress. Another pinafore of the same year, made of striped menswear suiting, featured two bold pockets at the bust. Her popular hipster pants were based on the styles that her husband had the fashionable tailor Dougie Hayward make for him. Quant was the first designer to use Poly-Vinyl-Chloride (PVC) in fashion; the first to introduce pantyhose in stunning colors to match her knitwear; and the first to introduce "fashion" lingerie—her seamless brassieres were called "booby traps," and her uplifting brassieres "bacon savers."

Quant also exerted a profound influence upon the representation of fashion by designing and commissioning young-looking animated mannequins and staging witty window displays. In her 1966 autobiography, she recalled one display in which "we had all the figures in bathing suits made of Banlon stretch fabric with madly wide coloured stripes like rugby sweat shirts. . . . The models were sprayed completely white with bald heads" (p. 8). In 1957 the trio (Mary, Alexander, and Archie) opened a second branch of Bazaar, designed by their friend Terence Conran, in London's Knightsbridge



**Models wearing Quant designs.** Quant's fashions were fun and irreverent, drawing heavily from the youth subcultures of London. One of her trademarks was updating traditional styles to make them more hip and trendy. AP/WIDE WORLD PHOTOS. REPRODUCED BY PERMISSION.

neighborhood. At the launch party, Quant's models danced to loud jazz music with glasses of champagne in their hands, "and floated around as if they had been to the wildest party or looking dreamily intellectual with a copy of Karl Marx or Engels in the other hand. . . . No one had ever used this style of showing. . . . At the end, the place just exploded!" (Quant, 1966, p. 95).

In 1962 Quant entered into a lucrative design contract with J. C. Penney, which had 1,700 retail outlets across the United States; and in 1963 she launched her own cheaper diffusion line, called the Ginger Group. Her talent was acknowledged that same year by the *Sunday Times*, which gave her its International Award for "jolting England out of its conventional attitude towards clothes" (Quant, 1966, p. 96). In 1966 she was awarded the Order of the British Empire and in 1967 she won the Annual Design Medal of the Royal Society of Arts. In the same year she opened her third shop, designed by Jon Bannenberg, in London's New Bond Street. Quant was awarded the Hall of Fame Award for Outstanding Contribution to British Fashion by the British Fashion Council in 1969.

Quant remained in fashion's vanguard throughout the first half of the 1970s. In 1971 she designed a spotted summer playsuit in cotton jersey called "Babygro," named after the ubiquitous babies' romper suits, and a long flared skirt printed with dots and daisies called

“Sauce,” which was teamed with a matching “Radish” bra-top. Summer evening dresses with plunging necklines, puffed sleeves, and ruffled skirts were made in pretty Liberty floral prints—once again borrowed from childrenswear—and glamorous striped Lurex. Quant’s sporty styles for 1975 included brightly colored and striped jumpsuits, many with drawstring waists and ankle ties, and sailor-inspired slit-sided tunic dresses worn over pants. In 1978 she introduced her own range of childrenswear. She has also designed furnishings and bed linens since the 1980s, and won numerous awards for her carpet designs.

Mary Quant always wanted to create a total fashion look—her own geometric hairstyle, cut by Vidal Sassoon, was widely copied. As an art student she had used Caran d’Ache crayons and a box of watercolors for her own makeup. In 1966 she startled the cosmetics industry by offering makeup in a staggering choice of wild colors as well as a more natural palette. The range was advertised using top model Penelope Tree, and photographed by Richard Avedon. Her book *Colour by Quant* was published in 1984, followed by *Quant on Make-Up* in 1986, and the *Classic Make-Up and Beauty Book* in 1996.

In 1990 Quant was awarded the British Council’s Award for Contribution to British Industry, and in 1993 she became a Fellow of the Society of Industrial Artists and Designers. Her cosmetics business is thriving as of the early 2000s; she has over 200 shops in Japan as well as outlets in London, Paris, and New York City.

*See also* Avedon, Richard; Children’s Clothing; Cosmetics, Western; Fashion Marketing and Merchandising; London Fashion; Miniskirt; Retailing; Youthquake Fashions.

**BIBLIOGRAPHY**

Harris, Martin, Interviewer. “Quantum Leap Back to the Street.” *Daily Telegraph*, 22 June 1994.

Morris, Brian. *Mary Quant’s London*. Museum of London, London, 1973. Extensively illustrated with an introduction by Ernestine Carter.

Quant, Mary. *Classic Make-Up and Beauty*. London: Dorling Kindersley, 1996.

———. *Quant by Quant*. London: Cassell and Company, Ltd., 1966. An entertaining and informative autobiographical insight into London’s postwar youth scene and the rise of Quant’s fashion empire.

———. *Make ‘Up’ by Mary Quant*. New York: Harper Collins, 1987.

Quant, Mary, and Felicity Green. *Colour by Quant*. London: Octopus Books, 1984.

*Amy de la Haye*

**QUILTING** Quilting is a technique whereby layers of fabric are sewn together, usually in order to make a warm bedcovering. Quilting can be performed in many ways,

but a quilt frame is often utilized to stabilize the layers while a quilter or group of quilters uses needle and thread to sew a running stitch through all the layers across the surface of the quilt. Hand-quilting was standard practice until the 1980s; by the twenty-first century, many quilters used sewing machines or long-arm quilting machines to sew the layers together. Sometimes the quilting stitches follow a decorative pattern; other times they are made in a basic grid format simply for their functional purpose of attachment.

Typically, a quilt consists of three layers. The top layer, often simply called the quilt top, is usually made up of fabrics sewn together to create a decorative design, either through the use of piecing (seaming fabric pieces together along their edges), or appliqué (attaching fabric pieces to a ground fabric). Whole cloth quilts are those whose tops are made up of a single piece of fabric (or pieces seamed together to imitate the appearance of a single piece) and which feature the quilting as their sole design element. The middle layer of a quilt is the batting, a sheet of loosely joined fibers, which provide loft and warmth. Traditionally, wool and cotton were used as batting; however, polyester also came to be used. The backing of a quilt, usually less decorative than the top, is usually made from plain muslin, a single printed fabric, or from old bed linens. Once all three layers have been attached with quilting stitches, the raw edges on all four sides are covered and joined with a long narrow piece of fabric called a binding.

**Quilting in History**

Quilting has been practiced all over the world for millennia. Quilting frequently was used in the past to construct warm or protective clothing. Evidence of quilted garments reaches as far back as pharaonic Egypt, as seen in a thirty-fifth century B.C.E. ivory carving (in the collections of the British Museum) depicting a pharaoh wearing a mantle or cloak that appears to be quilted.

In medieval Europe, quilted garments were used first as stand-alone armor and later as supplements to metal armor. Worn under metal armor, quilted garments protected the wearer from bruising and scratching by the heavy outer armor and absorbed some of the shock of weapon blows. Surviving kaftans and other garments in the collections of the Topkapi Saray Museum in Istanbul show that around the same time (sixteenth to seventeenth centuries), quilted clothing was also popular in Turkey.

By the eighteenth century, quilted clothing had become the height of fashion in Europe and colonial America. Although waistcoats and jackets were also sometimes quilted, quilted petticoats were especially popular. Dress styles eventually evolved to have an open panel in the front, extending outward and downward from the waist to the hem, in order to show off elaborately quilted petticoats.

By the late eighteenth century, quilting in Europe, the British Isles, and America was mainly used in the

construction of bedcoverings. Although quilted bedding had been made for centuries in Europe (the earliest surviving pieces are from Sicily, c. 1395), quilts became more common as fabrics imported by the East India companies and domestic textile production increased the availability of materials. Most of the late eighteenth-century quilts were whole cloth quilts, sometimes constructed from recycled petticoats (which had largely gone out of fashion by 1775). Whole cloth quilts were sometimes plain, with quilting as the main decoration, and sometimes embroidered. Piecing and appliqué were not as common, although extant pieces, such as a dated 1718 patchwork coverlet in the collection of the Quilter's Guild of the British Isles, prove that these techniques were not unknown.

Appliqué and piecing became the predominant techniques for creating quilt tops in the nineteenth century. Appliqué was more common during the first half of the century, but was largely superceded by piecing during the second half. Some quilts from the first half of the century, such as those in the so-called *broderie perse*, or cut-out chintz appliqué, style are thought to have been made to imitate *palampores*, printed Indian bedspreads. Baltimore album quilts, made in the Baltimore, Maryland, area between 1840 and 1850, are often considered the peak of the appliqué style, featuring highly detailed scenes and motifs.

The invention of the sewing machine during the 1840s, and its widespread use following the American Civil War, made piecing a faster, and therefore more popular, technique for creating a quilt top. Log cabin quilts are often the most recognizable nineteenth-century pieced style. Others include nine patch, triple Irish chain, and Bethlehem star.

During the first part of the twentieth century, technological advances strongly influenced quilting. Quilt kits made from die-cut fabrics in "Easter egg" colors produced with synthetic (rather than natural) dyes, are trademarks of 1920s to 1940s quilts. Amish quilts, first made during the last quarter of the nineteenth century, flourished in the first half of the twentieth century and became icons of American quilting. Quilts made by Amish women often feature simple pieced designs and intricate quilting designs similar to those found on whole cloth quilts of the late nineteenth century, hearkening back to an earlier era of quilting.

### Modern Quilting

After declining in popularity during the middle decades of the twentieth century, quilting has experienced a resurgence in the late twentieth and early twenty-first centuries. Sparked in the late 1960s and early 1970s by the women's movement and a few pivotal quilt exhibitions and conferences, quilting has enjoyed a revival that endured. In addition to the creation of quilts in the styles of earlier eras, studio artists are making quilts that push



**Woman quilting.** Until as recently as the 1980s, most quilts were made by hand. In proceeding decades, sewing or quilting machines were generally employed. © ROYALTY-FREE/CORBIS. REPRODUCED BY PERMISSION.

the boundaries of the traditional quilt aesthetic. Artists such as Michael James, Nancy Crow, and Faith Ringgold are creating pieces that prove that quilting continues to grow and thrive as a medium of expression.

See also **Appliqué; Sewing Machine.**

### BIBLIOGRAPHY

- Bassett, Lynne, and Jack Larkin. *Northern Comfort: New England's Early Quilts, 1789–1850*. Nashville: Rutledge Hill Press, 1998.
- Berlo, Janet, and Patricia Crews, eds. *Wild by Design: Two Hundred Years of Innovation and Artistry in American Quilts*. Seattle: University of Washington Press, 2003.
- Colby, Averil. *Quilting*. New York: Charles Scribner's Sons, 1971.
- Holstein, Jonathan. *The Pieced Quilt: An American Design Tradition*. New York: Galahad Books, 1973.
- Orlofsky, Patsy, and Myron Orlofsky. *Quilts in America*. New York: McGraw-Hill, 1974.
- Rae, Janet. *Quilts of the British Isles*. New York: E. P. Dutton, 1987.
- Smith, Tina F., and Dorothy Osler. "The 1718 Silk Patchwork Coverlet: Introduction." *Quilt Studies: The Journal of the British Quilt Study Group* 4/5 (2002/3): 24–30.
- Tezcan, Hulye, and Selma Delibas. *The Topkapi Saray Museum: Costumes, Embroideries and Other Textiles*. Translated by J. M. Rogers. Boston: Little, Brown and Company, 1986.

*Marin F. Hanson and Patricia Cox Crews*





**RABANNE, PACO** Paco Rabanne (1934– ) was born Francisco Rabaneda y Cuervo in Pasagès de San Pedro in the Basque region of Spain. His family fled to France in 1939 after his father was captured and executed by Francisco Franco’s troops. Rabanne studied architecture at the École nationale supérieure des Beaux-arts in Paris from 1951 to 1963. In 1963 he won an award at the Biennale de Paris for an inhabitable garden sculpture, which was exhibited at the Musée d’art moderne de la ville de Paris.

#### Early Career

Rabanne’s drawing skills made it possible for him to enter the world of fashion as early as 1955; indeed, to finance his architecture studies, he regularly supplied drawings of handbags for Roger Model and shoes for Charles Jourdan until 1963. In 1959 *Women’s Wear Daily* published seven sketches of dresses signed “Franck Rabanne.” Though this was the first time the designer’s name appeared in public, he chose “Franck” because the number of letters in the first and last names totaled a lucky thirteen. (He did not begin using the name Paco professionally until 1965.) These dresses bore the imprint of the style of Balenciaga, whose work was familiar to the young Rabanne through his mother, a former chief seamstress in the master’s workshop in San Sebastián in Spain.

Rabanne put his artistic gifts and the skills of his family to good use between 1962 and 1966: together they hand-produced unusual buttons and embroideries for the houses of haute couture. His clients at the time included Nina Ricci, Cristóbal Balenciaga, Maggy Rouff, Philippe Venet, Pierre Cardin, and Hubert de Givenchy.

In 1965, Rabanne’s creation of oversized *rhodoïd* jewelry in various geometric forms and bright colors brought him his first major commercial and media success. It also established one of the principles of his style: the use of rigid divisible materials held together by metallic rings or rivets.

Paco Rabanne’s first show took place on 1 February 1966 at the Hotel George V. This collection, which the designer called “Twelve Unwearable Dresses in Contemporary Materials,” was worn by barefoot models parading to the sounds of Pierre Boulez’s *Le marteau sans maître*, which Rabanne chose to reflect modernity and to

shock the audience. It was a veritable fashion manifesto and helped to establish Rabanne’s reputation as a revolutionary. On 21 April 1966, the dancers of the celebrated Parisian cabaret, the Crazy Horse Saloon, presented Rabanne’s collection of beachwear made of rhodoïd disks or leather. The dancers modeled the unconventional clothes in the form of a strip tease, creating another scandal. Rabanne also set up his workshop in 1966 at 33, rue Bergère, with a black décor accented with industrial scaffolding and bicycle seats for chairs.

#### Experiments in Design

Following the example of contemporary artists who had given up the traditional media of paint and canvas, Paco Rabanne chose to base his fashion experiments on a systematic challenge to the art of cutting and sewing. His work was characterized from the beginning by a complete rejection of traditional couture techniques in favor of the exploration of unusual materials and methods of assemblage.

Rabanne followed up his experiments in rhodoïd with garments made of metal, making metal something of a distinctive signature. He used it from one collection to the next in all its forms: disks and rectangles normally used to make protective aprons for butchers, coats of mail, hammered plates, aluminum jerseys, or elements of jewelry or decoration used as modified ready-mades. This work led Coco Chanel to call him “the metal worker.” Rabanne readily acknowledged that the recycling of ready-mades was very much in the tradition of the dadaists, such as his acknowledged master Marcel Duchamp.

He experimented with other materials, whether previously unknown to fashion or reimagined and redirected from their original purposes. Among Rabanne’s most notable creations were: paper dresses, which were presented in his collections in 1967, 1988, and 1992; molded clothing known by the name of the patented Giffo process, in which all the individual parts, including the buttons and pockets, were molded in a single block (1968); designs made from knitted fur (1967); and several made entirely of buttons (1970), wood (1977), coconuts (1993), or laser discs (1988). Far from being incidental, these experiments were developed according to a rigorous artistic and ideological perspective. In the process, they helped to free



**Paco Rabanne with several of his designs, 1977.** Rabanne was famous for creating strikingly unusual clothing from unlikely materials such as plastic, paper, and various metals. © JAMES L. AMOS/CORBIS. REPRODUCED BY PERMISSION.

the art of clothing design from its strictly utilitarian context, and they inspired many other designers to adopt their current positions.

The innovative and nonconformist character of Rabanne's work was recognized in avant-garde artistic circles. The gallery owner Iris Clert exhibited Paco Rabanne's creations in 1966 among those of other artists she supported, like Lucio Fontana. Salvador Dalí referred to his young compatriot as the second Spanish genius for his Unwearable Dresses collection. Rabanne's clothes also appealed to such 1960s icons as Brigitte Bardot and Françoise Hardy. It was also in this period that the cinema made the most frequent use of his dresses, so singular in appearance and so photogenic.

#### Other Activities

In the 1960s and 1970s Rabanne was in great demand as a costume designer for theatrical productions and ballets as well as films. His many noteworthy contributions to the cinema include: *Two or Three Things I Know About Her*, directed by Jean-Luc Godard (1967); *The Adventurers (Les aventuriers)* also known as "The Last Adventure," directed by Robert Enrico (1967); *Two for the Road*, di-

rected by Stanley Donen (1967); *Casino Royale*, directed by John Huston (1967); and *Barbarella*, directed by Roger Vadim (1968).

In addition to Rabanne's work in costume design, he produced a series of sophisticated perfumes. Calandre, launched in 1969 by the Spanish company Puig (which bought out Paco Rabanne in 1986), has proven to be one of the most successful contemporary fragrances. Subsequent fragrances have sold well also. Rabanne's perfumes, as well as his numerous licenses for other products around the world, have made it possible for the designer to continue his fashion experiments without suffering unduly from the low profit margins of haute couture.

In 1999, Rabanne decided to put an end to haute couture activity, while the ready-to-wear sector that he had developed since 1990 experienced new growth, particularly with the arrival in 2000 of Rosemary Rodriguez as the head of Rabanne's creative studio. Rodriguez has developed several collections in harmony with the very particular stylistic grammar of Paco Rabanne.

On the occasion of Rabanne's thirtieth anniversary as a designer, the first retrospective exhibition of his fash-

ions was presented in 1995 at the Musée de la Mode in Marseille, followed in 1996 by the bilingual publication of the first monograph devoted to his work.

Paco Rabanne has been involved since the late 1980s in several artistic projects beyond the confines of fashion, including the production of Mira Nair's film *Salaam, Bombay!* The film was awarded the Caméra d'Or at the Festival de Cannes in 1988.

In 1991 Rabanne published his first book, *Trajectoire*. He has since written several other works of reflection on mystical subjects and practices.

See also **Balenciaga, Cristóbal; Extreme Fashions; Givenchy, Hubert de; High-Tech Fashion; Paper Dresses; Paris Fashion; Perfume; Theatrical Costume.**

#### BIBLIOGRAPHY

- Kamitsis, Lydia. *Paco Rabanne: les sens de la recherche*. Translated by Sylvia Carter. Paris: M. Lafon, 1996.
- . *Paco Rabanne*. Paris: Editions Assouline, 1997. Translated by Harriet Mason. London: Thames and Hudson, Inc., 1999.
- Rabanne, Paco. *Trajectoire: d'une vie à l'autre*. Paris: M. Lafon, 1991.

Lydia Kamitsis

**RAINCOAT** A raincoat is a functional, lightweight single- or double-breasted waterproof coat, worn as protection from the rain. One of the most typically British of men's coats, it was created when Scottish chemist Charles Macintosh patented a waterproof fabric in 1823 and his name has become synonymous with the raincoat ever since. A raincoat, which is closely related to the riding mac in cut and color, should be cut large enough to fit over a suit, with a one-piece raglan sleeve (or with set-in sleeves and broad shoulders to accommodate wide-shouldered jackets), Prussian collar, and metal eyelets under the armpits to allow the arms to breathe.

#### History

Although not all outerwear needs to be waterproof, up to the turn of the nineteenth century the majority of outerwear on the market could not repel water unless specifically treated with oil. There had been many attempts to waterproof fabric effectively in the early part of the nineteenth century, but the actual method discovered by Charles Macintosh in the early 1820s was in fact intended for use for tarpaulin. He described his patented material as "India rubber cloth," whereby the texture of hemp, flax, wool, cotton, and silk, and also leather, paper, and other substances may be rendered impervious to water and air. It was made as a "sandwich" of two pieces of material surrounding a core of rubber softened by naphtha.

Macintosh warned tailors that the coats sewn from this material (without special precautions) would leak because of needle holes, but the "India rubber cloth" was

deemed such a success that tailors hurried to try to use it nevertheless. After some time Macintosh was forced to open his own shops to make coats with properly waterproofed seams in order to protect his reputation. His tartan-lined rubber cloth coat with fully sealed seams remains the iconic raincoat. However, because temperature always rises in the rain and because rubberized cloth is nonporous, the raincoats were liable to make the body perspire when worn. London manufacturer George Spill discovered a solution to this by inserting metal eyelets under the armpits; such eyelets continue to be used in many raincoats.

During World War I, Thomas Burberry devised a weatherproof coat for the officers in the trenches, made of a fine-twilled cotton gabardine that was put through a chemical process to repel water while allowing the fabric to breathe. The "trench coat" was not totally waterproof, but was effectively water resistant under most weather conditions and the raglan sleeves, which allow for ease of movement, as well as the gabardine fabric used, became the norm for waterproof coats of later years.

Basic styles of raincoats have changed little since World War II, but raincoats for both men and women started being offered in a wide range of colors, in contrast to the older tans and grays that once were the only colors available. Advances in fiber and fabric technology, including surface treatments of fabrics, have made modern raincoats more water-repellent than ever before.

Although men and women in the early twenty-first century rely on cars, trains, and buses to protect them on the way to work—and the raincoat remains a business overcoat—the raincoat remains as popular a form of protection from the rain as it was when it was first conceived.

See also **Outerwear; Rainwear; Umbrellas and Parasols.**

#### BIBLIOGRAPHY

- Amies, Hardy. *A, B, C of Men's Fashion*. London: Cahill and Co Ltd., 1964.
- Byrde, Penelope. *The Male Image: Men's Fashion in England 1300–1970*. London: B. T. Batsford, Ltd., 1979.
- Chenoune, Farid. *A History of Men's Fashion*. Paris: Flammarion, 1993.
- De Marley, Diana. *Fashion for Men: An Illustrated History*. London: B. T. Batsford, Ltd., 1985.
- Schoeffler, O. E., and William Gale. *Esquire's Encyclopedia of 20th Century Fashions*. New York: McGraw-Hill, 1973.
- Wilkins, Christobel. *The Story of Occupational Costume*. Poole: Blandford Press, 1982.

Tom Greatrex

**RAINWEAR** The primary function of rainwear—outerwear including raincoats, trench coats, mackintosh coats, rain slickers, rain parkas, and even oilskin coats—is to protect the wearer from the cold, rain, and sleet



while preventing penetration of moisture to whatever is being worn underneath.

Unlike most coats and jackets—which are usually appropriate for a particular occasion—rainwear manufacturers have to respond to the functional needs of the wearer: the classic case of form following function. But although fashion is often a secondary consideration when it comes to rainwear, most rainwear items nevertheless are also expressions of style.

### History

The original mackintosh raincoats dating from the early 1820s were of a fairly crude construction and awkward appearance. The “India-rubber cloth” designed by the Scottish chemist Charles Mackintosh, consisting of two layers of cotton cemented with a layer of rubber, was not originally intended for outerwear at all, but instead was developed to waterproof tarpaulin.

The mackintosh concept was seized upon by tailors, even though problems arose as needle holes greatly decreased the material’s ability to protect against the rain. Mackintosh eventually developed a process to seal the seams, and his name became synonymous with rainwear. Even as late as 1900 almost any raincoat was referred to as a mackintosh.

In the first decade of the twentieth century, many raincoats were still being made of rubber, and were cut long enough to reach a man’s ankles and made in either single- or double-breasted styles.

### World War I

The biggest development in the rainwear category came with the need to provide an all-weather coat to the officers serving in the trenches during World War I. The London firm of Burberry owned the patent to a fabric of fine cotton gabardine that had been chemically processed to repel rain in order to protect shepherds and farm workers in wind-swept rural England. Although the Burberry cloth coat had been used by some officers during the Boer War (1899–1902), it was not until 1914 that the brand would receive the approval of the British war ministry.

More than 500,000 Burberry coats were produced for the war effort, and these “trench coats,” as they would become known, very quickly became the official coat of Allied fighting men. Characterized by its shoulder tabs, a collar with storm flap, and D-shaped rings on the belt (to which pieces of a military kit, such as a water bottle or hand grenade, could be attached) the trench coat was produced by Burberry as well as by the London firm Aquascutum—each featuring its company’s distinctive house-check lining.

Hundreds of thousands of trench coats have been sold in the early twenty-first century, but they are more likely to be worn by someone ready to do battle on New York’s Wall Street or in London’s Square Mile than on the muddy fields of the Somme or Ypres. Versions of the

trench coat have graced the catwalks of Yves Saint Laurent, Giorgio Armani, Chloe, and Moschino. In 2004, the original trench coat was still an Aquascutum and Burberry staple item, one that seems to epitomize British style for many American and Japanese consumers. It thus has been highly successful as a piece of military attire as well as a stylish, practical, and iconic piece of clothing.

### Post-World War I

By 1928, the rainwear of choice had become the French aviation coat. Similar to the trench coat, a French aviation coat was most frequently double-breasted with raglan sleeves, and was often cut in gabardine lined with oiled silk and lined with a plaid wool to ensure the coat was both warm and dry. Like the trench coat, the aviation coats also had belted waists as well as straps of gabardine at the ends of the sleeves and would become known as an all-weather coat.

During the 1930s, there was a trend toward a wider skirted, looser hanging style of coat. This was in fact excellent for keeping rain from the body, taking into account that the gabardine from which it was constructed was only water-repellent rather than waterproof. In 1934 *Men’s Wear* explained: “A coat is like a tent. An ordinary tent of canvas will not leak in a driving shower, as long as you do not scrape the underside. Touch the underside and the water will begin to seep through instead of shedding off. The same principle applies to a loose fitting coat” (p. 27). Oiled silk and cotton raincoats and rubber ponchos also began to make an appearance at the time.

Not a great deal else changed in rainwear fashions, leaving aside color trends (it was fashionable to wear white raincoats in the 1930s, for example, and instead of blocks of color, different shades and tones were employed) and occasional changes in the typical length of a raincoat, until the 1953 introduction of a raincoat made from 50 percent cotton and 50 percent polyester. The London Fog, as this coat would become known, was the first on the market that was both water-repellent and washable. It was originally brought out as a single-breasted raglan and as a double-breasted trench coat, with a third style (a single-breasted belted trench coat with zippered sleeve pocket) added later.

The Peacock Revolution, born in Carnaby Street in the 1960s, would see many women’s-wear designers cross over to the menswear realm, and inevitably their influence was noticed in rainwear. The Sherlock Holmesesque raincoat with cape made a reappearance, as did houndstooth raglan coats. With the vogue for highly shaped suits, raincoats with wide Napoleon collars and flared lines soon appeared. At this time, and during the 1970s, the raincoat graduated from being a solely functional item to fashion “must have,” something that has continued well into the twenty-first century with Burberry and Aquascutum raincoats and trench coats being fashion essentials almost 100 years after they were first conceived.

See also **Outerwear; Raincoat; Umbrellas and Parasols.**

#### BIBLIOGRAPHY

- Amies, Hardy. *A, B, C of Men's Fashion*. London: Cahill and Co. Ltd, 1964.
- Barnes, Richard. *Mods!* London: Plexus Publishing Limited, 1979.
- Byrde, Penelope. *The Male Image: Men's Fashion in England 1300–1970*. London: B. T. Batsford, 1979.
- Chenoune, Farid. *A History of Men's Fashion*. Paris: Flammarion, 1993.
- De Marley, Diana. *Fashion for Men: An Illustrated History*. London: B. T. Batsford, 1985.
- Keers, Paul. *A Gentleman's Wardrobe*. London: Weidenfeld and Nicolson, 1987.
- Roetzel, Bernhard. *Gentleman: A Timeless Fashion*. Cologne: Konemann, 1999.
- Schoeffler, O. E., and William Gale. *Esquire's Encyclopedia of 20th Century Fashions*. New York: McGraw-Hill, 1973.
- Wilkins, Christobel. *The Story of Occupational Costume*. Poole: Blandford Press, 1982.

*Tom Greatrex*

**RAMIE** Ramie (pronounced Ray-me), one of the oldest textile fibers, comes in two forms. *Boehmeria nivea* is also known as white ramie or China grass. It has been cultivated in China for thousands of years under the name *zharma*. *Boehmeria nivea* (*var. tenacissima*) is also known as green ramie or rhea.

#### Properties of Ramie

**Advantages.** Ramie fibers come from the stems of the plant. They are harvested just before or right after the flowers bloom by cutting near the roots. The stems are processed in a manner similar to that used for transforming flax fibers into linen fabrics. The ramie stems go through the following steps to produce fibers suitable for spinning: (1) decortication—breaking up the hard outer bark to create long ribbons of bark and fiber; (2) degumming—immersing the fiber in caustic soda and heating in a closed container; and (3) washing and drying.

#### Producers of Ramie

The leading producers of ramie include China, Taiwan, Korea, the Philippines, and Brazil. Ramie is also produced in India, Thailand, Malaya, Queensland (Australia), Mauritius, the Cameroons, West Indies, Mexico, the southern states of the United States, and in south Europe.

#### Uses of Ramie

Ramie fibers were used for burial shrouds in ancient Egypt and ancient China. They have been used for centuries in Korea for the hanbok, Korea's traditional costume.

Ramie has for the most part been used in the country in which it was produced. In the 1970s a loophole in

the Multifiber Arrangement (MFA) allowed ramie fiber to be exported without import restrictions as long as at least 50 percent of the fabric was made of ramie. This encouraged the use of ramie in blends and contributed to its popularity in the 1970s and 1980s. The MFA was modified in 1986, thereby closing the loophole.

In the twenty-first century, ramie, either in blends or alone, is used for a wide range of clothing: dresses, suits, sportswear, and underwear. Other uses include gas mantles for lanterns, ropes, nets, fire hoses, table linens, filter cloth, upholstery, straw hats, and sewing thread.

#### Care of Ramie Textiles

Since ramie used for apparel is most often blended with other fibers, the care of the fabric can vary. Fabric made from 100 percent ramie may be machine washed, machine dried, and ironed at high temperatures. Dry cleaning (if safe for the dyes and finishes used) is best at preserving the color, shape, and wrinkle-free appearance of fabrics made of ramie fibers.

See also **Fibers; Korean Dress and Adornment; Shroud.**

#### BIBLIOGRAPHY

- Collier, Billie J., and Phyllis G. Tortora. *Understanding Textiles*. 6th ed. Upper Saddle River, N.J.: Prentice Hall, 2000.

#### Internet Resources

- "Ramie." In *The 1911 Edition Encyclopedia*. Available from <<http://18.1911encyclopedia.org/R/RA/RAMIE.htm>>.
- Korean Information Overseas Information Service. "Ramie Clothes." Available from <<http://www.korea.net/learnaboutkorea/library/magazine/pictorial/199908/19990801.html>>.
- Scruggs, Barbara, and Joyce Smith. "Ramie: Old Fiber —New Image." Ohio State University Extension Fact Sheet (HYG —5501–90). Available from <<http://ohioline.osu.edu/hyg-fact/5000/5501.html>>.
- Tondl, Rose Marie. "Ramie." Nebraska Cooperative Extension (NF 91–45). Available from <<http://ianrpubs.unl.edu/textiles/nf45.htm>>.
- Wood, Ian. "16.2 Ramie: The Different Bast Fibre Crop." *The Australian New Crops Newsletter*, no. 11 (January 1999). Available from <<http://www.newcrops.uq.edu.au/newslett/ncn11162.htm>>.

*Elizabeth D. Lowe*

**RATINE.** See **Yarns.**

**RAYON** Rayon, acetate, and lyocell are all regenerated cellulose fibers. They originate from chemical treatment of natural materials. The materials most often used are cotton fibers too short to spin into yarns or wood chips. The Federal Trade Commission establishes generic categories of fibers for regulation and labeling purposes.

The generic classification “rayon” includes several variants. *Viscose rayon* is the most common form. A variation of viscose, *high-wet-modulus rayon* was produced in 1955 with trade names of Avril and Zantrel as a modification to generate high strength, reduce elongation, and improve washability of rayon. *Cuprammonium rayon* is subjected to slightly different processing. U.S. cuprammonium production ceased in 1975, but it is still produced in Japan (FiberSource Web site; Kadolph and Langford 2001).

Acetate has its own generic category, which also includes a variant, triacetate. Triacetate is a manufactured cellulosic that is similar to acetate but limited in production and usage. (Collier and Tortora 2000). Lyocell was given its own classification by the FTC for labeling purposes, but it was also designated as a sub-classification of rayon.

Rayon, the earliest manufactured fiber, was first patented in 1855 by the Swiss chemist Georges Audemars. It was called “artificial silk.” Sir Joseph Swan, an English chemist, was inspired by Thomas Edison’s incandescent electric lamp to experiment with extruding Audemars’s cellulose solution through fine holes into a coagulating bath in order to create filaments for the electric light. His fibers were used in Edison’s invention as well as for an 1885 exhibition of textiles his wife crocheted from his new fiber. “Artificial silk” was also exhibited at the Paris Exhibition in 1889 by the French chemist Count Hilaire de Chardonnet who is known as the “father of the rayon industry” because he built the first plant for commercial production of “Chardonnet silk” in Besancon, France.

The French chemist Louis-Henri Despeissis patented cuprammonium rayon producing what he called “Bemberg silk” as early as 1908. A British silk company, Samuel Courtauld and Company, Ltd., began production of a rayon known as viscose rayon in 1905 and by 1911 helped start American Viscose Corporation in the United States (FiberSource Web site; Encyclopaedia Britannica 2003). Some researchers theorize that getting access to the science of producing rayon was such a benefit for the United States that it contributed to American involvement in World War I (Clairmonte and Cavanagh 1981).

The invention of acetate was rapidly followed by commercial production, as early as 1910. In Switzerland, Camille and Henry Dreyfus created acetate motion picture film and toilet articles and during World War I built a plant in England to help the war effort with cellulose acetate dope for airplane wings. The Dreyfus brothers were invited to build an acetate plant in Maryland to provide cellulose acetate dope for American airplanes. The Celanese Company began commercial production of acetate fiber in 1924. Both rayon and acetate garments were available to consumers by the 1920s. Confusion between the two fibers was partially due to the Federal Trade Commission designating both as rayon. This was not corrected until 1953 when rayon and acetate were given separate generic fiber classifications.

Cellulosic manufactured fibers reached peak production in the 1980s with a market share of 21 percent. Fiber was produced in North America, Europe, and Asia. By 2002, Asia had become the leading manufactured fiber producer with 65 percent of the market and cellulose had dropped to 6 percent of fiber production (FiberSource Web site). Given that polyester production soared while cellulose dropped, it seems that polyester became accepted as the most optimal “artificial silk.”

Lyocell, developed as a “better” manufactured cellulosic, may be fundamental to reinventing enthusiasm for manufactured cellulosic fibers. Introduced to the U.S. market in the early 1990s, lyocell is sold under the trademark Tencel by Tencel, Inc., and by the Austrian producer Lenzing AG as Lyocell by Lenzing. Promoted as a designer level apparel textile that is more environmentally friendly than rayon, lyocell promotions tended to downplay association with rayon and focused on being a new textile with considerable potential for comfort and aesthetic appeal.

***Producing rayon, acetate, and lyocell fibers.*** Although each manufacturing process has technical differences and variations in the steps, the basic procedure for the manufacture of rayon and lyocell begins with wood chips or cotton linters. These materials are treated with chemicals and subjected to various treatments, depending on the end product. Eventually these materials are reduced to a cellulosic solution. This solution passes through spinnerets, patterned after the small holes that silkworms use to extrude silk filament, and dries to become mostly pure cellulose filaments.

Wood pulp or cotton linters are also used in production of acetate, however, as a result of the chemical treatments, the fiber produced is no longer pure cellulose, but rather a form called cellulose acetate. As a result, the characteristics of acetate differ from those of the purely cellulose fibers. Acetate was the first thermoplastic fiber, a fiber that will soften and melt when exposed to high levels of heat (Kadolph and Langford 2001).

In the manufacture of lyocell, chemicals can be recovered and recycled, making lyocell one of the most environmentally friendly fibers to produce. Rayon and acetate involve considerable potential for hazardous chemical by-products. Efforts have been made to recycle chemicals and minimize environmental impacts, but the strict environmental pollution regulations in the United States have led many American manufacturers to discontinue rayon production.

***Characteristics of rayon, acetate, and lyocell textiles.*** Rayon and lyocell have high absorbency, low heat retention, and soft, non-irritating surfaces that make them comfortable next to the skin in warm weather. Both can also be manipulated to emulate the aesthetic character of cotton, wool, silk, and linen. Additionally, lyocell has the capacity to simulate the aesthetics of silk, suede, and leather.



By contrast, acetate has more heat retention and less absorbency and is subject to static electricity build-up.

Viscose rayon and lyocell tend to be produced as staple (short) fibers and thereby have a textured surface that softens light reflectance. Acetate fibers are typically produced as filament fibers, and as a result acetate is more successful in simulating the luster and body of silk in such fabrics as taffeta and satin. Both rayon and lyocell dye easily although color will fade over time and with abrasion. Acetate was difficult to dye and subject to fading until synthetic solution dyes were developed to solve this problem. Acetate now is produced in a wide color range and color stability is good when fabrics are exposed to sunlight, perspiration, air pollution, and cleaning. Acetate is dissolved by fingernail polish remover containing acetone and is damaged by extended exposure to sunlight.

Unless it is the high wet modulus type, rayon has poor durability and resiliency. Rayon and acetate perform better if dry-cleaned than if laundered because they are weaker when wet. Acetate also has poor abrasion resistance and is sensitive to chemicals. While rayon may shrink or be distorted after laundering unless given special finishes, acetate is dimensionally stable. Lyocell is much stronger when wet than rayon or acetate and is considered to have good durability and dimensional stability. Resiliency is better than either rayon or acetate. Lyocell can be successfully washed by using the gentle cycle and can be pressed with a warm iron. Wrinkle-resistant treatments do not greatly affect strength. Lyocell has potential to fibrillate, which results in a fuzzy appearance on the surface. This is beneficial for a textured surface but makes the fabric subject to abrasion damage. New variations developed to lower fibrillation contribute to the versatility of this promising textile. Lyocell is often manufactured in microfiber (ultrafine) form to enhance the extremely soft feel and drape.

A major concern with acetate is its reaction to heat and to fire. While acetate wrinkles easily, it fuses and melts if ironed at high temperatures. Acetate also burns readily, as do all cellulose fibers, but spits molten pieces while burning that melt and fuse to the skin. Acetate is mildew and insect resistant. (FiberSource Web site; Kadolph and Langford 2001; Collier and Tortora 2000).

***Rayon, acetate, and lyocell in fashion across time.*** Early in the twentieth century, rayon and acetate were both explored as an economical alternative to silk. The marketing of both fibers became confused as acetate was first sold as a form of rayon labeled “acetate rayon.” Following World War I, which temporarily disrupted fiber development, consumers experienced problems with shrinkage and distortion of rayon and the thermoplasticity of acetate that had to be addressed. World War II disrupted access to silk fiber. Manufacturers in the United States used this opportunity to expand the market for rayon and acetate, allowing them to be accepted as new fibers rather than silk substitutes.

New fibers competed with rayon and acetate in the postwar period. While consumers enjoyed their low cost, unpredictability of performance was a deterrent. Use of manufactured cellulose fibers has declined. The large market share of polyester in the 2002 market leads one to assume that the aesthetic of silk is still important, but better performance than either rayon or acetate tend to provide has become a higher priority (FiberSource Web site).

Lyocell may be an exception to this downward trend. Manufacturers have been careful to differentiate lyocell from rayon. As a new fiber, it has a cachet of novelty and designer level taste that fits well with fashion. Recently, the versatility of Tencel lyocell is being expanded through new finishing processes that expand options for the aesthetic character of the final textile or garment (American Fiber Manufacturer’s Association). Having the aesthetic of cellulose fibers with better performance and the aura of being good for the environment may help lyocell become the manufactured cellulose fiber of choice.

***Common rayon, acetate, and lyocell textile uses.*** Rayon is used for a range of apparel as either 100 percent rayon or blended to create blouses, dresses, suiting, sport shirts, work clothes, slacks, and accessories. Interior products are also frequently blended and primarily include upholstery, draperies, slipcovers, bed coverings, and tablecloths. High wet modulus rayon tends to be used in knitwear and lingerie. Nonwoven applications for rayon are also extensive due to its high absorbency. These include cosmetic “cotton” balls, industrial wipes, reusable cleaning cloths, disposable diapers and sanitary products, and medical surgical materials. High tenacity rayon can be used for tire cords and other industrial products (Collier and Tortora 2000; Kadolph and Hollen 2001; FiberSource Web site).

Acetate fiber is primarily used for linings and also special occasion apparel, such as taffeta, satin, and brocade wedding and prom dresses. It is commonly found blended with rayon in interior textiles, such as antique satin or brocade draperies, textured upholstery, and bedspreads and quilts. Acetate is used for cigarette filters.

Because it is nearly twice the price of rayon, lyocell has been targeted primarily to upscale apparel, such as business wear, dresses, slacks, and coats. Recent innovations resulting from the Tencel Inc., Intellect research program has moved lyocell into more formal wear, such as men’s suits. Lyocell is also being seen in lingerie, hosiery, and casual wear. Interior uses include upholstery and draperies. Lyocell can be blended with cotton, wool, linen, silk, nylon, and polyester, a broad range of possibilities for combining fiber characteristics. New modifications have made production of lyocell knitwear optimal.

#### BIBLIOGRAPHY

Clairmonte, Frederick, and John Cavanagh. *The World in Their Web: Dynamics of Textile Multinationals*. London: Zed Press; Westport, Conn.: L. Hill, 1981.

Collier, Billie, and Phyllis Tortora. *Understanding Textiles*. New York: Macmillan, 2000. Contains good illustrations.

Hatch, Kathryn. *Textile Science*. Minneapolis, Minn.: West Publishing, 1993. Contains good illustrations.

Kadolph, Sara, and Anna Langford. *Textiles*. 9th ed. New York: Prentice-Hall, 2002. Contains good illustrations.

*Internet Resource*

“A Short History of Manufactured Fibers.” Available from <<http://www.fibersource.com>>.

Carol J. Salusso

**READY-TO-WEAR** The textile and apparel industry constitutes the largest global manufacturing employer with approximately 200 nations involved in production resulting in \$313.5 billion in trade during 1996. Of this amount, \$163.3 billion was derived from apparel, the tenth largest trade category in the world. The apparel industry comprises many small but interrelated firms. Making garments to sell as ready-to-wear is labor intensive but to initiate production requires less capital investment and less advanced technology than many other businesses. Women constitute the majority of the labor force worldwide and have found apparel a continuing source of employment throughout history. These factors have made the business of ready-to-wear clothing of particular importance to the economies of developing nations in the twentieth and early twenty-first centuries, and to entrepreneurs in many earlier eras.

The illustrated chart shows the relationships of the many associated firms involved in the production of all price levels of ready-to-wear. In the modern industry, these firms are located in many different parts of the world. Thus production emphasis is now placed on the coordination and logistics of each aspect of the process.

There are four aspects of ready-to-wear with historic antecedents that remain important businesses in the twenty-first century. The most common is the speculative production of fashionable garments to be sold at retail as described in the chart. Secondly, commissioned garment production, for example military uniforms, differs from speculative production in the nature of financial risk because there is no need to sell at retail. Thirdly, the used-clothing market has traditionally been a ready-made clothing source for the poor. However, the enormous growth of used clothing as a viable and expanding business in the late twentieth and early twenty-first centuries is notable for the breadth of its market, which reaches almost all socioeconomic levels through resale and thrift shops as well as auctions. Due in part to the relaxation of standards of dress, in part to popular culture and in part to affluence in the last quarter of the twentieth century, used clothing is an important sector of the current ready-to-wear market. Firms that provide services for international trade via shipping and logistics

constitute a fourth important and profitable aspect, especially because of the decentralization of the modern industry.

**Pre-Industrial Ready-to-Wear: Speculative Production**

Speculative production began in antiquity with garments and accessories traded internationally. For example, ready-to-wear was part of ancient Babylonian business life as recorded on clay tablets dating from 1400 to 1200 B.C.E. A merchant there wrote to his associates to instruct them to open his warehouse, take out garments from his sealed chests and from the chests of garments returned to him by another merchant. He instructed them to “Write your tablets as follows: they have taken so-and-so many garments from the chest, so-and-so many from the regular deliveries have not been received, so-and-so many are from the garments returned to me—and send all the tablets to me” (Oppenheim, p. 85). These instructions are not unlike inventories taken in modern industry.

Speculative production requires capital investment and the ability to assume the risks inherent in recouping investment through the sale of merchandise at a profit. In the pre-industrial era such production included useful but semi-fitted garments. After 1350, as clothing became more fitted, shirts and accessories such as collars, hair nets, hats, and gloves became the primary kinds of products traded. In Renaissance Florence, embroidered detachable sleeves could be purchased ready-made and were also exported. London customs records for the second half of the sixteenth century show gloves from Belgium, Spain, and Italy imported by the gross; hair nets, straw hats, and caps from France by the dozen; as well as knitted nightcaps, gloves, stockings, and petticoats. Sixteenth-century London silkwomen, who processed imported raw silk from Italy into thread, could weave ribbons and other trimmings to make silk accessories which they sold in their own shops along with imported silk items, such as hair nets, netted neckwear, and netted sleeves. Elsewhere, women did most of the work of making small accessories, and such products were ordered and sold through men’s trade guilds.

**Pre-Industrial Ready-to-Wear: Commissions and Donations**

Commissions were given for the provisioning of armies, household retainers, or charitable donations. In ancient Rome records indicate that garments were produced in factory-like settings with perhaps 100 workers, and that some early form of mass production outfitted the Roman legions. Commissions also feature in later European religious rituals and charitable donations. For example, in the annual Maundy Thursday foot-washing ceremony, Elizabeth I of England (1533–1603) provided a woolen gown, a pair of shoes, and a smock—mass produced at



**New York tailors, circa 1890.** Around the turn of the century, many arriving immigrants with tailoring skills found work producing clothing in New York City, the center of the American ready-to-wear industry. © HULTON-DEUTCH COLLECTION/CORBIS. REPRODUCED BY PERMISSION.

her expense—to as many women as equaled the years of the queen’s age. In another sixteenth-century example, a wealthy citizen of Nuremberg, Germany, provided in his will of 1577 that each year on 31 October, 100 poor men would be provided with a coat, waistcoat, and trousers of black wool, a black hat, a white linen shirt, and a pair of shoes. This particular donation continued until 1809 and required two master tailors and their journeymen to use specific patterns, standard measures, and materials purchased from specified vendors, requirements similar to practices in twenty-first century ready-to-wear. Wealthy individuals might also provide in their wills for mourning clothes to be made and given to mourners at their funerals.

#### **Pre-Industrial Ready-to-Wear: Used Clothing**

By far the most widespread and common source of ready-to-wear clothing in the pre-industrial era was the used

clothing market. Throughout Europe records beginning in the Middle Ages document dealers in used clothing, often women, who supplied many in the lower socioeconomic levels for whom new clothing was too expensive. Used clothing dealers sometimes rented stalls in market areas designated for their trade, or simply sold their wares on the streets. A retail guild including dealers in second-hand clothing was organized in Florence, Italy, in 1266. The necessity for having used clothing available is apparent in the following examples from Nuremberg, Germany, in 1509 where a new coat given to a servant girl by her employer was equal to 56 percent of her annual income, and the fabric provided for a servant’s coat and trousers was 148 percent of his annual wage. Some members of the upper classes also purchased used clothing, most of which was acquired by dealers at estate sales. During plague years, when there was fear of infection, used clothing markets were closed.





**Model of Shannon Rodgers-designed dress, 1973.** Rodgers would skillfully select an element of haute couture design and incorporate it into several ready-to-wear fashions. © CONDÉ NAST ARCHIVE/CORBIS. REPRODUCED BY PERMISSION.

### Pre-Industrial Ready-to-Wear: International Trade

International trade in ready-to-wear garments and accessories increased as other regions of the world opened to European business in the sixteenth century. By the seventeenth century some larger ready-made garments, such as the *banyan* or *Indian gown* for men, and the *mantua* for women, were imported to Europe. Both were T-shaped garments similar to caftans, and were considered informal dress.

The first merchant ship to fly the flag of the United States, *The Empress of China*, sailed for the Orient in 1784. Its cargo of Virginia ginseng was traded at Canton, China, for porcelains and soft goods including ready-made umbrellas, 600 pairs of ladies' mitts; six pairs of ladies' satin shoes, more than 250 pairs of men's satin breeches, and a large number of textiles. On the second voyage in 1786, the ship returned with similar wares that included more than 600 pairs of satin breeches. These cargos were consigned to merchants who advertised the contents up and down the east coast of the United States.

Bristol, England, had more than 200 merchant houses trading internationally by the late eighteenth century, exporting felt hats, worsted caps, stockings, hosiery, footwear, and wearing apparel such as canvas frocks, trousers, shirts, jackets, and drawers. As part of the slave

trade, this kind of ready-made clothing was traded in Africa to buy slaves and sold in America and the West Indies to provide clothing for slaves. Similar ill-fitting loose clothing was provided for sailors and was known as slops.

### Early Industrialization of Ready-to-Wear in the United States

Merchant tailors, long prevented from making clothing on speculation because of guild restrictions and lack of capital, began to work in mass production during the nineteenth century. Systems of standardized and proportional measurements enabled them to make better fitting ready-to-wear at more affordable prices. The introduction by 1820 of a tape measure marked in inches made more standardization possible. Statistics kept for soldiers in the American Civil War helped determine how men's measurements could be better adapted for mass production. Ebenezer Butterick's 1863 patent for the sized paper pattern provided increased standardization for women's garments. During the first half of the nineteenth century, mass produced ready-to-wear clothing was almost exclusively for men. Only mantles and cloaks with little fit were produced for women.

In the early years of industrialization, labor costs remained cheaper than fabric, with women and boys doing much of the sewing by hand at home while the pattern making, cutting, and inspection of finished goods were under the supervision of the tailor in his shop. At the end of the nineteenth century, immigrants met the growing need for labor. Many arriving with tailoring and dressmaking skills found work producing ready-to-wear in New York City, the center of the American ready-to-wear industry.

### Early Industrialization: The Sewing Machine

The first technological innovation impacting industrial garment making directly was the sewing machine. Following developments by Elias Howe and Isaac Singer among others, Nathan Wheeler and Allen B. Wilson made and marketed a machine clothing manufacturers found efficient because it allowed fabric to feed evenly on curved seams. The sewing machine made possible the piecework concept of factory organization where each step was performed by a different person, eliminating the need for skilled workers.

Steam-powered sewing machines in factory workrooms were used from the early 1850s to produce men's shirts and collars, and were then adapted for the production of suits for men and boys. Overcoats of heavy cloth could be sewn by machine in three days instead of six by hand. The business of women's cloaks and mantles as well as crinolines and hooped petticoats was improved by the use of the sewing machine, and consequently these items became cheaper when ready-made. Women's fashions using braids and trimmings increased as machines made the application easier.

Improvements to the sewing machine continued, with 7,339 patents for sewing machines and accessories

granted between 1842 and 1895. Technologies for cutting and pressing were the last fundamental industrial processes to be developed. The most successful mechanism for cutting multiple layers of cloth arrived in 1890, and the modern pressing machine was developed in the first years of the twentieth century.

### Clothing Distribution after 1850

The nature of clothing distribution changed in the second half of the nineteenth century with the creation of department stores in large urban centers in Europe and North America. With these stores came greater variety for the consumer and the advent of advertising to influence choice. Department stores appeared in the early 1850s, and, by the end of the century had become enormous architectural wonders that encompassed many kinds of merchandise including ready-made garments for men, women, and children. Although these large stores offered products through illustrated catalogs, their focus was on the urban population.

In the United States, Aaron Montgomery Ward established a mail-order business in 1872 offering to furnish "Farmers and Mechanics throughout the Northwest with all kinds of Merchandise at Wholesale Prices." Sears, Roebuck and Company followed in 1893. By 1920, Ward's catalog had grown from a single sheet to 872 pages, and Sears' 1921 edition was 1,064 pages with the first 96 pages devoted to women's clothing, followed by 40 pages for men and boys. In addition to illustrated catalogs, women's magazines, first appearing in Europe at the end of the eighteenth century, proliferated throughout the nineteenth century. Initially limited fashion coverage focused on illustrations featuring the latest fashions, their materials and colors, and sometimes the providers. By the end of the nineteenth century, more pages were given over to product advertisements.

### Speculative Production of Ready-To-Wear as a Mature Industry

By the 1920s mass production and mass merchandising were fully integrated into the ready-to-wear industry. The focus of advertising had shifted from declarations of quality to exhortations urging readers to keep up with fashion, and from an emphasis on men's wear to one on women's wear. This gave impetus to the modern industry's strategy of rapid fashion change. The women's ready-to-wear industry in the United States became concentrated in New York City between Sixth Avenue and Ninth Avenue from 35th Street to 41st Street, where 65 percent of the women's garment workers were employed by 1940. The proximity of manufacturers to labor and suppliers as well as associated businesses gave New York firms the flexibility to react quickly and efficiently to changing fashions. Employment in the domestic American apparel industry peaked in 1950 at 1.4 million.

Jerry Silverman, Inc., a manufacturer of women's better dresses, organized in 1959, provides an example of

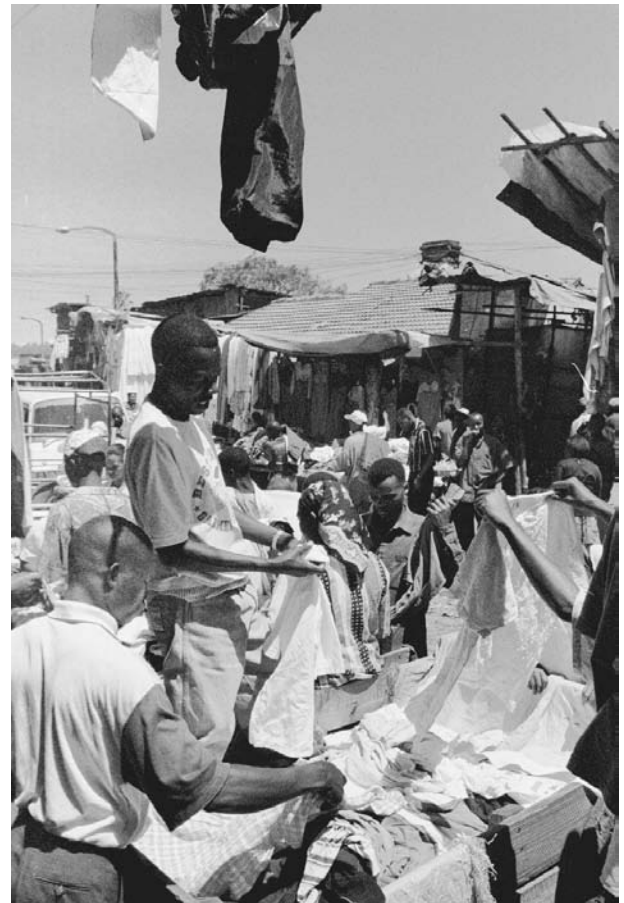

**Used goods sold in open-air market.** People sort through used clothing at this outdoor market in Kenya in 2000. Because of the poor economy and resulting widespread poverty, this type of business forms an integral part of Kenya's informal economy. © AP/WIDE WORLD PHOTOS. REPRODUCED BY PERMISSION.

typical production processes. In 1970 Silverman sold dresses at wholesale from \$39.75 to \$89.75 to about 3,000 stores nationwide, where they cost the consumer from \$70 to \$175. Not including CMT (cut, make, trim) contractors, the firm employed about eighty people. Shannon Rodgers, the firm's designer, had his name on the label, an unusual acknowledgment when most designers working for manufacturers remain anonymous.

To develop a concept for his ready-to-wear line in a given season, Rodgers went to Europe to view collections. The industry in the United States usually depends on Parisian fashion ideas, especially for silhouette and color. However, the complex and detailed French haute couture (fine, luxurious made-to-order clothing) cannot be directly copied for ready-to-wear garments intended to fit thousands of consumers. Rodgers was skilled at taking single elements of a haute couture design, for example, a skirt detail, a neckline treatment, or a sleeve style,



**Women sew clothes at a textile mill.** Women constitute the majority of the labor force in the apparel industry throughout the world. © BROWNIE HARRIS/CORBIS. REPRODUCED BY PERMISSION.

and incorporating them into various garments, getting perhaps six ready-to-wear ideas from a single haute couture garment. These trips also gave Rodgers ideas for fabric choices that would give the finished garment the texture, volume, and movement he envisioned.

After sketches for the line were completed, fabrics and trimmings were purchased and a sample produced in company workrooms. Once the sample had been approved, it was sent to the pattern maker, graded into various sizes, and sent out to be duplicated for fashion show and showroom use. The Silverman fashion show for retail buyers and the fashion press usually featured about 100 different styles. Initial orders from buyers were confirmed after approval from the stores they represented. The success of the business depended on the quantity of confirmed orders and timely delivery—first of the fabrics and trimmings for production and then of the finished garments to the stores—as well as keeping production costs minimized.

Outside contractors cut the garments, bundled the pieces of each individual dress, and sent the bundles to machine operators for sewing. After sewing, the garments were finished, pressed, and returned to the Silverman Company for a final quality check and proper labeling. Labels included the firm's label, "Shannon Rodgers for Jerry Silverman," the union label, fiber content and cleaning instructions, style and size, and the store label and price tag.

Next came the firm's promotion and advertising to prepare customers for the new season. Once the finished garments had been shipped and received by the store, retail display, promotion, and advertising began. The sales-

person and the customer at the point-of-sale completed the business process.

### **U.S. Ready-to-Wear Production in the Late Twentieth Century**

By the early 1960s, manufacturers in the United States began to look for cheaper labor costs and production facilities off-shore. This resulted in a decrease in domestic apparel employment to 684,000 by 1999. It also resulted in a new focus on the logistics of coordinating off-shore production facilities where each part of an ensemble might be manufactured in a different country but is expected to reach the stores as a complete look. Modern communication and transportation make this kind of decentralized production process possible. Another significant change in late twentieth and early twenty-first century ready-to-wear is the importance of marketing strategies to product development.

Procedures associated with a retailer acting as manufacturer, or jobber, for merchandise bearing the store's private label, offer an instructive comparison with mid-twentieth century processes. In the 1990s, beginning at least 15 months in advance of the arrival of the garments in the store, the design director, color specialist, and product merchandisers would consult color and textile services and view collections in Europe and America. Fabric specialists and product merchandisers then shopped for yarns and textiles at major textile trade fairs. The initial line concept including color, mood, theme, silhouette, fabrics, and key components was presented to the product management team. The design team planned their internal strategy and refined the line concept before they joined the product merchandisers to make a final presentation to store committee members and management. Samples were reviewed and target prices agreed to before trips abroad to select contractors. Five months before the products were due to be shipped, the line was finalized and contracts signed. The products reached the stores six to eight weeks from the shipping date.

In order to track production at distant sites and cut costs even further, some mass-market firms use video-conferencing and other sophisticated technologies to send and receive information, thereby insuring product quality without the need to travel to the producer. As the time frame for fashion changes in ready-to-wear becomes more compressed, communication technology becomes more essential to success.

### **Conclusion**

Innovations in transportation, communication, and technology have been major forces for change throughout the history of ready-to-wear clothing production. Additionally, rapid fashion changes have influenced the modern apparel industry by compressing the production timetable. However, the production of ready-to-wear apparel has been consistently labor intensive, leading modern manufacturers to seek lower labor costs by repeatedly moving production facilities. Challenges faced by the industry in



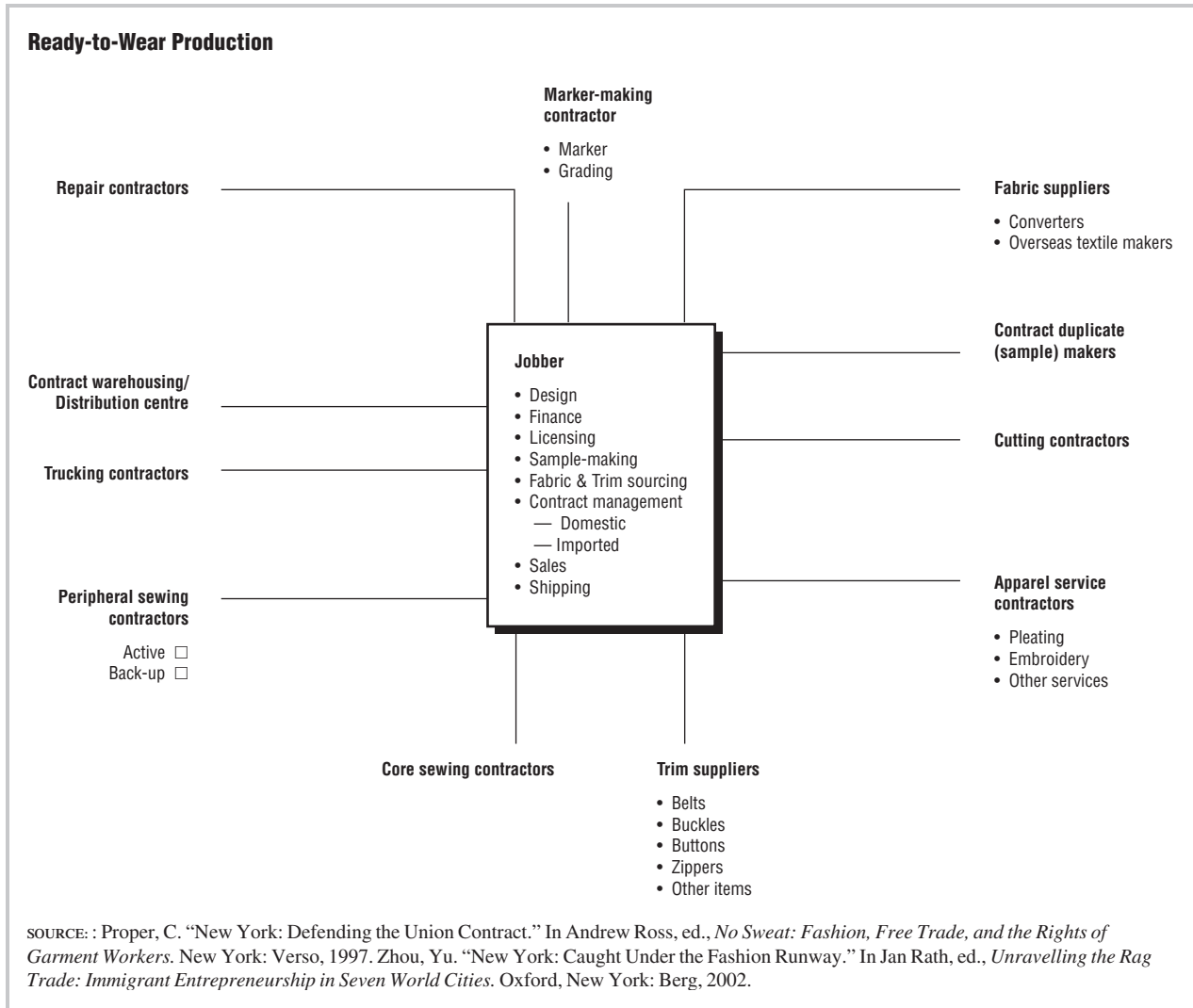

the early twenty-first century remain similar to those faced in earlier eras, particularly in the area of speculative production where the customer must be inclined to purchase at a price that yields a profit to the manufacturer.

See also **Fashion Industry; Seventh Avenue; Sewing Machine; Sweatshops.**

**BIBLIOGRAPHY**

Arnold, Janet. "Smocks, Shirts, Falling Bands and Mantuas: Evidence of Loosely-Fitting Garments and Neckwear Produced for the Ready-to-Wear Market, c. 1560–1700." In *Per una Storia della Moda Pronta, Problemi e Ricerche* (A History of Ready to Wear, Problems and Research). Proceedings of the Fifth International Conference of CISST (The Italian Center for the Study of the History of Textiles), Milan, 26–28 February, 1990. Firenze: EDIFIR, 1991.

CISST. *Per una Storia della Moda Pronta, Problemi e Ricerche* (A History of Ready to Wear, Problems and Research). Proceedings of the Fifth International Conference of CISST (The Italian Center for the Study of the History of Textiles), Milan, 26–28 February, 1990. Firenze: EDIFIR, 1991.

Dickerson, Kitty G. *Textiles and Apparel in the Global Economy*. 3rd ed. Upper Saddle River, NJ.: Prentice-Hall, Inc., 1999.

Druesedow, Jean L. "Designing for Off-shore Manufacture in the New York Ready-to-Wear Industry." In *Per una Storia della Moda Pronta, Problemi e Ricerche* (A History of Ready to Wear, Problems and Research). Proceedings of the Fifth International Conference of CISST (The Italian Center for the Study of the History of Textiles), Milan, 26–28 February 1990. Firenze: EDIFIR, 1991.

Frick, Carole Collier. *Dressing Renaissance Florence*. Baltimore: The Johns Hopkins University Press, 2002.

Kidwell, Claudia B., and Margaret C. Christman. *Suiting Everyone: The Democratization of Clothing in America*. Washington, D.C.: The Smithsonian Institution Press, 1974.

Levitt, Sarah. "Bristol Clothing Trades and Exports in the Georgian Period." In *Per una Storia della Moda Pronta, Problemi e Ricerche* (A History of Ready to Wear, Problems and Research). Proceedings of the Fifth International Conference of CISST (The Italian Center for the Study of the History of Textiles), Milan, 26–28 February, 1990. Firenze: EDIFIR, 1991.

Oppenheim, A. Leo. *Letters from Mesopotamia: Official Business and Private Letters on Clay Tablets from Two Millennia*. Translated and with an introduction by A. Leo Oppenheim. Chicago: University of Chicago Press, 1967.

Rath, Jan, ed. *Unravelling the Rag Trade: Immigrant Entrepreneurship in Seven World Cities*. Oxford and New York: Berg, 2002.

Seidel, Jutta Zander, "Ready-to-Wear Clothing in Germany in the Sixteenth and Seventeenth Centuries: New Ready-Made Garments and Second-Hand Clothes Trade." In *Per una Storia della Moda Pronta, Problemi e Ricerche* (A History of Ready to Wear, Problems and Research). Proceedings of the Fifth International Conference of CISST (The Italian Center for the Study of the History of Textiles), Milan, 26–28 February, 1990. Firenze: EDIFIR, 1991.

Smith, Philip Chadwick Foster. *The Empress of China*. Philadelphia: The Philadelphia Maritime Museum, 1984.

Tortora, Phyllis G., and Keith Eubank. *A Survey of Historic Costume: A History of Western Dress*. 3rd ed. New York: Fairchild Publications, 1996.

Zhou, Yu. "New York: Caught under the Fashion Runway." In *Unravelling the Rag Trade: Immigrant Entrepreneurship in Seven World Cities*. Edited by Jan Rath. Oxford and New York: Berg, 2002.

Jean L. Druesedow

garneted into new yarns. Even though the textile industry has been utilizing used fibers for at least 150 years, the markets for recycled textile fiber continue to evolve.

The textile recycling process functions as a multifaceted system that occurs along a pipeline of inter-related constituents that not only turns pre- and post-consumer waste back into fiber, but also is extracting new fiber from domestic waste. Specifically, PET (polyethylene terephthalate), the chemical substance from which some polyester is made, is reclaimed from plastic soda bottles. Although recycling is politically correct and ecologically friendly, 4–6 percent of landfills are comprised of recyclable textile products since discarded clothing and textile waste fail to reach the recycling pipeline, primarily because consumers do not understand the recycling process. The Council for Textile Recycling reports that the per capita consumption of fiber in the United States is 67.9 pounds with over 40 pounds (59 percent) per capita being discarded per year. Of countries where statistics are available, the United Kingdom deposits the highest percentages (90 percent) of textile waste to the landfill, compared to 65 percent from Germany, 30 percent from Denmark, and 20 percent from Switzerland.

**RECYCLED TEXTILES** Textile recycling is one of the oldest and most established recycling industries in the world, yet, few people understand the industry and its myriad players. Textiles have been recycled since the eighteenth century when the Napoleonic War caused virgin wool shortages and required that wool fibers be

**A Global Problem**

Western consumption patterns encourage excessiveness that leads to a negative impact on global sustainability. By implementing textile recycling, global sustainability increases. Two important issues regarding the global nature of textile recycling include: (1) textile waste is cre-

Recycled Textiles: Source, Usage, and Benefits		
Source	Usage	Primary Benefit
Wearable post-consumer clothing	Export to less developed countries	Cost
	Disaster relief	Charity
	Vintage collectibles	Premium resale
Non-wearable post-consumer clothing	Wipers	Cost Ecological
Polyester/cotton manufacturing waste	Feedstock for engineered plastics	Energy savings
		Cost
		Relative weight
		Abundance of materials
Shoddy mungo	Insulating pads Bedding Blankets	Cost
		Durability
Linters	Cotton felts	Cost
Fiber waste	Paper pulp	Low water absorption
	Hi-density composite	Does not release harmful chemicals
	Fibrous composites	
	Laminated composites	
	Particulate composites	
	Concrete filler material	
Recycled PET	Fleece outerwear	Thermal properties
	Carpets	Environmental



### GLOSSARY OF TECHNICAL TERMS

**Clippings:** Waste generated from a sewn-products cutting room.

**Cream:** Goods in like-new condition that have not been circulated in the consumer market.

**Deadstock:** A product that is not useable or saleable.

**Garnet:** To separate fabric into the fibers from which it is made by using a machine with needlike teeth that pull the fabric apart.

**Mill Overruns:** Anything made for first quality but not used, e.g. overproduction.

**Mungo:** Fibers extracted from woven garments. Fibers obtained by this method are very short and must be mixed with longer fibers to enable successful spinning.

**Needlepunch wipers:** Wipers manufactured from textile waste products.

**PET:** Thermoplastic polyester based on polyethylene terephthalate, i.e. recyclable plastics.

**Post-Consumer Textile Waste:** Textile waste from the home.

**Pre-Consumer Textile Waste:** Waste produced from manufacturing processes.

**Rag Sorter:** A company that grades post-consumer textile waste based on product, condition, or material content.

**Reworkable waste:** Waste from the manufacturing process that can be fed more or less directly back into the process.

**Shoddy:** Fibers produced from knitted garments

**Soft waste:** Waste from the manufacture of garments and yarns, mixed with new fiber by spinners to produce cheaper yarns.

**Textile MRF:** A facility that grades and sorts post-consumer waste.

**Vintage Used Clothing:** Reused clothing that has become fashionable or has collectible value.

**Wipers:** Squares cut from any cloth or material used to clean or polish.

Some of these glossary terms specific to the textile recycling industry have been adapted from the *Council for Textile Recycling Buyers Guide and Directory*, Bethesda, Md.: Council for Textile Recycling, 1995.

ated and disposed of on a global scale, and (2) much of the used-clothing market is located in developing countries where annual wages are sometimes less than the cost of one outfit in the United States. For many people in developing countries, it is necessary to be able to receive used clothing surplus from industrialized nations. Simpson (1996) reports that nearly 34,000 tons of used clothing is sent to Africa annually. Because not all countries allow the importation of used clothing, black markets have risen as goods move across borders to meet market demands.

The three primary areas for processing of reclaimed apparel are Prato, Italy; Dewsbury, United Kingdom; and, more recently, India. These processing centers obtain used apparel from all over the world, sort items based on color and fiber content, mechanically reduce the apparel back to a fiber state, then reprocess into new yarns and end products.

#### The Process of Recycling Textiles

The range of markets for used textile fiber varies from vintage collectibles; to used clothing exported to less de-

veloped countries, to industrial uses. Traditional sources of textile waste come from three different sources:

1. fiber, yarn, and fabric processing
2. sewn products manufacture
3. discard at the end of its useful life

Textile and cutting wastes at the manufacturing level are considered pre-consumer waste and are easier to recycle because the fibers, dyes, and finishes are known and in like-new condition. Post-consumer waste is of uncertain origin and has a wide variance in quality and condition, making it more difficult to recycle. Ongoing research and development focuses on the problem of processing used, mixed fibers.

Most post-consumer textiles are collected by charity organizations, but it is impossible for charities to utilize all of the collected clothing so they sell the balance to rag graders. Approximately 500 textile recycling companies in the United States are responsible for diverting 775,000 tons of post-consumer textile waste from the landfills. These "rag sorters" sort used clothes for export, wipers, and fiber and fabric manufacturers (Council for Textile Recycling 1997). Although textile-recycling processors





**Women sorting recycled textiles.** Textile recycling companies sort through clothing for fabrics that can be reclaimed for industrial use and those that can be sent to needy people in developing countries. PHOTOGRAPH TAKEN BY JANA M. HAWLEY, TAKEN IN PRATO, ITALY. REPRODUCED BY PERMISSION.

have historically purchased their inventory by weight from charity surplus, they have recently begun to expand their base of suppliers by helping municipalities develop curbside and drop-off textile collection programs. Almost half (45 percent) of the collected goods are recycled as secondhand clothing, typically sold to markets in developing countries. Thirty percent is used for the wiper industry and another 26 percent are converted to new raw materials used primarily as stuffing or insulation pads

See also **Polyester; Secondhand Clothes, Anthropology of; Secondhand Clothes, History of; Textiles and International Trade.**

#### BIBLIOGRAPHY

- Council for Textile Recycling. "Don't Overlook Textiles!" Council for Textile Recycling, 1997.
- Goodard, Robert, and Daly Herman. "Environmental Sustainability: Universal and Non-Negotiable." *Ecological Applications* 6, no. 4 (1996): 1002–1117.
- Hawley, Jana M. "Textile Recycling as a System: The Micro-Macro Analysis." *Journal of Family and Consumer Sciences* 92, no. 4 (2001): 40–46.
- Meis, M. "Consumption Patterns of the North: The Cause of Environmental Destruction and Poverty in the South:

Women and Children First." Geneva, Switzerland: United Nations Commission on Environment and Development, 1991.

Platt, Brenda. "Weaving Textile Reuse into Waste Reduction." Washington, D.C.: Institute for Local Self Reliance, 1997.

Watson, Jacky. *Textiles and the Environment*. New York: The Economist Intelligence Unit, 1991.

*Jana M. Hawley, Pauline Sullivan,  
and Youn Kyung-Kim*

**REENACTORS** Reenactors, referring to themselves sometimes as "living historians," are individuals who publicly recreate historical events and eras by donning historical dress and emulating period behavior. For most it is a hobby or pastime, occurring among all age groups and genders in varying locations around the world. People in the United States can be found reenacting the European medieval era, the American Revolutionary War, the early 1800s westward expansion, World War II, and other events. In the early 2000s the most popular era, judged by the frequency of reenactments and number of participants, is the American Civil War.

The best reenactors carefully craft the persona of individuals from the past. They refer to this activity as creating an “impression.” To develop a credible impression reenactors must be authentic, which is indicated by the closeness to which a reenactor approaches exact replication of the “historical personage, place, scene, or event from the past” (Handler and Saxton, p. 243). Serious reenactors invest a great deal of time researching their historical impressions to ensure authenticity. In fact, achieving authenticity in reenacting is viewed as an “index of performance competence” (Turner, p. 127). Those who master authenticity are admired by their fellow reenactors, and those who do not are frequently ridiculed by their peers.

Replicating period material culture is an important necessity for achieving authenticity. In other words, dress and accessories must give every appearance of being from the past. For the sake of authenticity reenactors spend considerable time and money buying and/or creating costumes congruent with their historical personae. For example, a first-rate Civil War uniform, including trousers, jacket, shirt, underwear, shoes, and hat can cost several

hundred dollars. In addition, accessories such as a musket, military leathers, and bedrolls can push the entire investment to well over one thousand dollars. Great care is taken to ensure that historical anomalies are not apparent in the reenactor’s kit or ensemble. Some even go so far as to count the number of thread stitches per inch in a garment’s construction. “The objects of reenactment become deeply treasured emblems of identity . . . The form these objects take is guided by a collective aesthetic . . . of painstaking detail and accuracy ” (Turner, p. 126).

#### Why Do People Reenact?

Much of the scholarly literature on reenacting is focused on reenactor motivation. Allred regards reenacting as a postmodern “flight from an age of isolation and fragmentation into an age of community and shared ideals” (p. 7). Handler and Saxton also place reenacting in postmodern context, suggesting that “practitioners seek . . . an authentic world . . . to realize themselves through the simulation of historical worlds” (p. 243). Hall postulates that reenacting is a postmodern, nostalgic impulse in re-



**American Civil War reenactors.** Serious reenactors spend great amounts of time and care in assembling their costumes. Authenticity is the key, and often participants will pay hundreds of dollars to get every detail correct. © KEVIN FLEMING/CORBIS. REPRODUCED BY PERMISSION.

sponse to social, political, and economic turmoil of late capitalism. Turner sees reenacting as a public expression of self where the sense that reenactor's make of the past form "themes [for] self-examination" (p. 134). "For some [reenacting] is a political statement, for others an affirmation of cultural identity . . . individuals discover the themes that apply to themselves and their lives" (p. 130). For example, Belk and Costa find reenactors challenging a "number of American values such as reverence for nature, frontier as freedom, individualism, materialism, and statusless egalitarianism" (p. 32).

### Confederate Civil War Reenacting

Most Civil War reenactments are local/regional affairs, taking place in park-like settings, attracting reenactors from the host state and surrounding region. Several hundred reenactors representing both Confederate and Federal armies typically participate together in an event. Throughout the year, a handful of national reenactments are also staged, where several thousand reenactors might convene. Most reenactments commemorate a specific Civil War battle; however, unlike the actual war, the events are generally conducted on weekends, with the arrival of the reenactors on a Friday evening. They quickly and efficiently establish separate Confederate and Union camps, characterized by an expanse of canvas tents and a multitude of cook fires. It is not unusual to see horses and cannons, representing cavalry and artillery. Separating the two military camps is usually a civilian camp, containing nonmilitary reenactors and sutlers who supply the reenactors with their "period" material needs. Saturday and Sunday activities entail military drills and staged battles. Other activities during the weekend might include a period religious service, recruiting rally, and military ball. By late Sunday afternoon, the reenactors break camp and return to their everyday lives.

There are many reasons why Confederate reenactors participate in the hobby. Strauss has identified several key motivations: a love of Civil War era history, an opportunity to play a role "larger than life," social bonding, and perhaps most disturbing, some reenactors express discontent with the outcome of the Civil War and the resultant erosion of white hegemony in the United States. Consider the reenactor from Michigan, whose eyes burned with intensity when he said, "I do this because I believe in what they believed in . . . my ancestors fought for the Confederacy" (Strauss 2001, p. 150).

Why would unhappy white hegemonists couch themselves within the hobby of Confederate reenacting? Because expressing whiteness, a subtle form of racism, publicly in a more overt manner can be problematic. In the United States overt racism is a stigmatic behavior, and to avoid stigma, Confederate reenactor expressions of whiteness are embedded within the pageantry of a widely accepted public pastime. In essence, Confederate reenactors are able to veil their protestations symbolically and keep them politically correct and publicly palatable.

Of all the elements used by Confederate reenactors to project themselves and their sense of whiteness, the importance of appearance in the form of dress cannot be overemphasized. Without the uniform, there would be no reenacting. The uniform is used to step into character and to drape history over the shoulders of the reenactor. Without the uniform, the stage upon which history is replayed evaporates, and without the reenactor's stage the projection of the white self in a publicly palatable manner becomes virtually impossible.

See also **Military Style**.

### BIBLIOGRAPHY

- Allred, Randal. "Catharsis, Revision, and Reenactment: Negotiating the Meaning of the American Civil War." *Journal of American Culture* 19, no. 4 (Winter 1996): 1–13.
- Belk, Russell W., and Janeen Arnold Costa. "The Mountain Man Myth: A Contemporary Consuming Fantasy." *Journal of Consumer Research* 25, no. 3 (December 1998): 218–240.
- Dobratz, Betty A., and Stephanie L. Shanks-Meile. *The White Separatist Movement in the United States: "White Power, White Pride!"* Baltimore: Johns Hopkins University Press, 1997.
- Hall, Dennis. "Civil War Reenactors and the Postmodern Sense of History." *Journal of American Culture* 17, no. 3 (Fall 1994): 7–11.
- Handler, Richard, and William Saxton. "Dyssimulation: Reflexivity, Narrative, and the Quest for Authenticity in 'Living History.'" *Cultural Anthropology* 3 (1998): 242–260.
- Singer, Mark. "Never Surrender: The Sons of Confederate Veterans Have a Bad Day at the Mall." *The New Yorker* (14 May 2001): 52–56.
- Strauss, Mitchell D. "A Framework for Assessing Military Dress Authenticity in Civil War Reenacting." *Clothing and Textiles Research Journal* 19, no. 4 (2001): 145–157.
- . "Identity Construction Among Confederate Civil War Reenactors: A Study of Dress, Stage Props, and Discourse." *Clothing and Textiles Research Journal* 21, no. 4 (2003): 149–161.
- . "Pattern Categorization of Male U.S. Civil War Reenactor Images." *Clothing and Textiles Research Journal* 29, no. 2 (2002): 99–109.
- Turner, Rory. "Bloodless Battles: The Civil War Reenacted." *The Drama Review* 34, no. 4 (1990): 123–126.

Mitchell D. Strauss

**RELIGION AND DRESS** The interaction between religion, culture, and dress is fascinating. Dress can be a window into the social world, which is bound by a tacit set of rules, customs, conventions, and rituals that guide face-to-face interaction. To many religious organizations, clothing is an important symbol of religious identification. However, for most groups, the regulation of personal appearance goes beyond clothing. The term dress as it is used here includes clothing, grooming, and all forms of body adornment. Dress also includes behaviors related to the control of the body, such as dieting, plastic





**Orthodox Jewish attire.** An Orthodox Jewish man teaching children Hebrew. Orthodox Jews cultivate a distinctive appearance, including the hat and beard visible here, as a sign of their beliefs. © DAVID TURNLEY/CORBIS. REPRODUCED BY PERMISSION.

surgery, and cosmetics. Holistically, then, dress functions as an effective means of nonverbal communication. Ideas, concepts, and categories fundamental to a group, such as age, gender, ethnicity, and religion, help to define a person's identity that is then expressed outwardly through a person's appearance. Both individual and group identity is projected through dress because people use self-presentation and self-promotion to visually present identity that is congruent with their belief systems.

### The Sacred and the Secular

Where religion is concerned, clothing can be divided into two categories often referred to as the sacred and the secular (or profane). In some instances, what is treated as sacred is merely a garment that has important cultural implications with regard to gendered power. In patriarchal religions where the perception is that males are given the responsibility of seeing to the enforcement of religious rules, some garments become associated with the sacred primarily through the prescription and enforcement of a dress code. The most recent example of the conflation of gendered power and dress is the prescrip-

tion that women in Afghanistan in the early 2000s were required to wear the burqa (or *chadaree*).

While secular dress is not exclusively associated with religious activities, secular dress is used in ritual or is worn by certain religious practitioners such as the clergy. Dress used for religious ceremonies and rituals is referred to as ecclesiastical dress; modern dress for Roman Catholic priests resembles dress from the early days of the Christian church when the clergy were not distinguished from other male members of the church by their dress. However, in the sixth century as fashion changed, the clergy did not adopt the new fashions and continued to wear the older styles. Ecclesiastical dress has become a form of fossilized fashion, a phenomenon where the garments worn seem frozen in time and continues to be worn even as other forms of dress evolved.

A common theme with regard to liturgical garments worn by male clergy is the de-masculinization of sacred dress. For many religions, sacred dress for male clergy commonly avoids pants in favor of loose, flowing robes. Because hair is symbolic of sexuality, it is controlled in

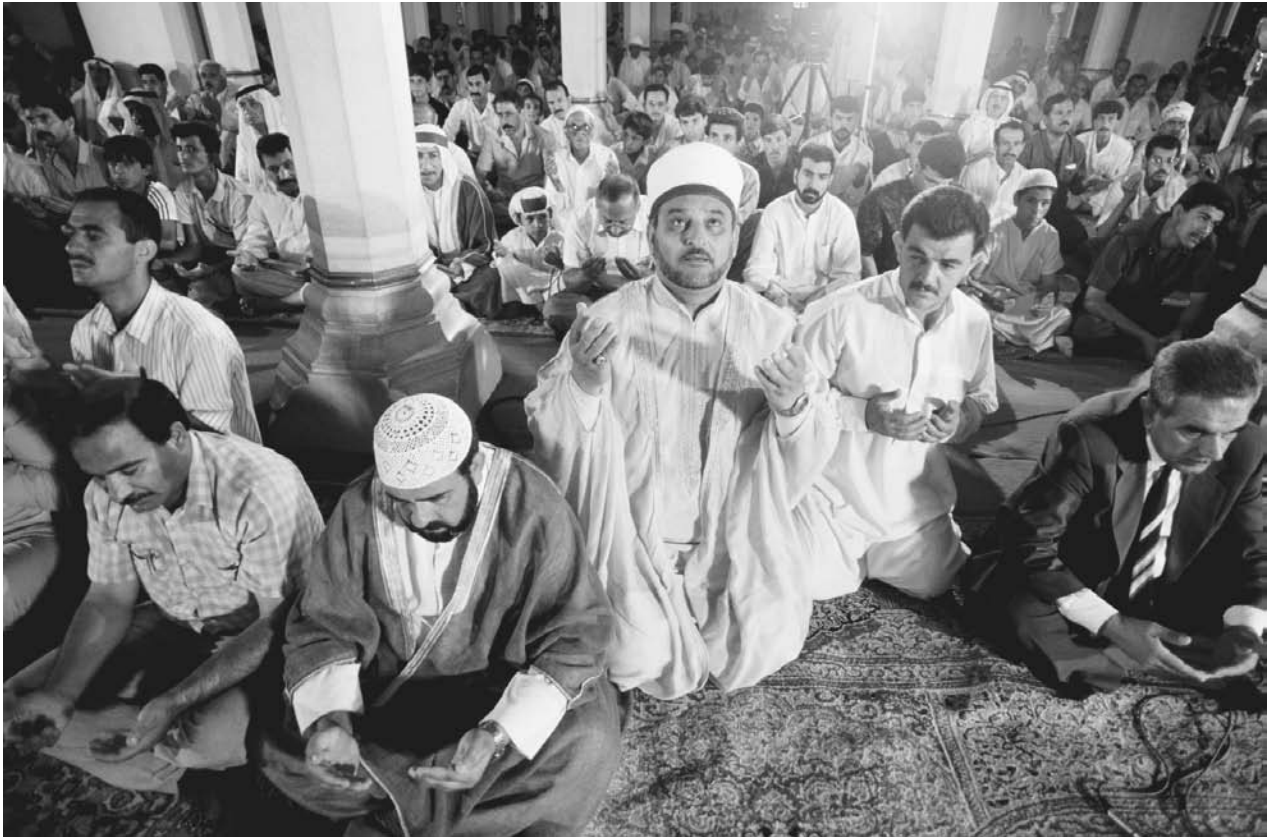

**Muslim men at prayer.** A wide variety of clothing styles can be seen among these Muslim men. While some are in traditional dress, many are wearing western attire, both formal and informal. © PETER TURNLEY/CORBIS. REPRODUCED BY PERMISSION.

many religions. Some orders of priests, nuns, and monks shave their heads, remove a lock of hair, or cut their hair to symbolize their turning away from the pleasures of the world.

Interestingly, everyday dress for certain ethno-religious subcultures, such as Hasidic Jews, Amish, and conservative Mennonites, is considered sacred, especially in the symbolic separation of the ethno-religious subculture from a dominant culture. As religious groups encounter social change, dress often symbolically becomes important as certain items of a religious group's clothing may be classified as sacred in contrast to what is considered secular. Generally the most symbolic dress features of Amish and Mennonites (hats, beards, head coverings, bonnets, aprons) are considered sacred. Similarly, among conservative Muslim women, very fashionable clothing may be worn underneath the veils (sacred garments), known as *chador*, *chadaree*, or *burqa*, that are seen by outsiders. Sacred dress worn externally then becomes used intentionally to visually separate these religious groups from the larger culture. Often, the rules as to dress codes are imposed by male clergy on female members of the community, and in doing so, these patriarchal religious societies intentionally use dress codes to maintain a gendered imbalance of power.

Some religions have sacred garments that are not visible to outsiders. Mormons who have been to temple wear sacred undergarments beneath otherwise ordinary clothing. The sacred undergarments reinforce their commitment to their religion.

### Religious Ideologies

Organized religion has used dress in two related ways: to maintain the customs and traditions of the organization, thereby establishing a visual identity for the religion; and to simultaneously control the individual identities of its members by symbolically denoting dress as in-need of control. Religions create dress codes to overtly define morality and modesty while covertly controlling sexuality. Fundamentally, dress codes are less about clothing than about the control of the body by the more powerful church members who enforce their groups' ideologies. Religious dress codes express group identity and simultaneously function as a means of reinforcing male patriarchal control.

When a religion uses dress to reinforce tradition, it will usually be seen in opposition to fashion, which by its very nature is dynamic. Religious dress will change slowly as organized religions often reject fashion as an attempt to focus on individuality rather than salvation.

To understand how dress is expressive of religious ideologies, it is helpful to understand how each of the world's major religions perceives the role of dress as a means of identity expression. In a later section, more detail will be given as to how particular religious groups use dress to establish sectarian identities.

Hinduism is a polytheistic religion encompassing a holistic view of life in which the inner self is highly valued, and life in the world is seen as temporary. Reincarnation is a belief at the base of both the caste system and religious expression. The individual works through levels of moral development that are indicated by caste. It is believed that the higher the person's caste, the closer the individual is to the spiritual world. Since the focus in Hinduism is on the inner self, dress, an expression of the external self, is less important. Dress is tradition bound, and slow to change by comparison to costume found in other religious groups. Dress and adornment in Hindu society does show a person's caste, level of piety, or the specific god to which the individual is devoted.

Islam is the newest of the major religions and its followers are commonly referred to as Muslims. This religion emphasizes the group over the individual, and Islamic ideology focuses on male power and the separation of the sexes through both physical and visual means. Dress codes for Muslims have great impact on daily life, which involves frequent religious expressions and rituals. Among Muslims, codes of modesty go beyond the covering of women's bodies to include restriction of women's behavior. The Koran requires women to dress modestly, but does not specifically state that they must wear veils. Dress codes regarding veiling vary among Islamic families and cultures; however, among the most conservative Islamic groups the requirements for women to wear veils are seriously enforced. In addition to their ostensible function to protect gender segregation, these rules also are intended to slow down assimilation that began after World War II when westernization started in Islamic societies. As western dress became common, the Islamic fundamentalist movement began pushing for a return to tradition. Modest dress and veils became symbolic of both the acceptance of patriarchal power and nationalism. Throughout the larger cities in Iran, posters announced the specifics of the dress code requiring women to dress in chadors that cover all but the face. In Afghanistan under Taliban control, women were killed if they did not wear the all-enveloping burqa or *chadaree*.

Judaism, the oldest of the major monotheistic religions, is based on the concept that people exist to glorify God; to be appropriately dressed, then, is a religious duty. Historically, the ancient Jews had customs that indicated dress was seen as symbolic. Since the upper body was seen as pure, but the lower body was perceived as impure, Jews wore girdles to make the division between pure and impure visibly clear. Morality was connected with dress early on; Moses forbade nudity. Similarly, he forbade Jews from wearing the clothing of non-Jews in



**An Amish girl.** In an example of fossilized fashion, the Amish continue to dress in the same style that was prevalent when they originated in the seventeenth century. This practice serves both to set the Amish apart from the rest of society and to demonstrate their beliefs and traditions. © DAVID TURNLEY/CORBIS. REPRODUCED BY PERMISSION.

an attempt to keep his people separate from influences that might lead to assimilation. In recent times, levels of Judaic conservatism are denoted by dress where the most assimilated Jews dress like non-Jews. However orthodox and Hasidic Jews wear specific garments to visibly show their religious conservatism.

Christianity is less clear about values pertaining to dress than is Judaism. Values in Christian theology relating to the body are conflicting; women's bodies are seen as the site of temptation, in that male sexual guilt is projected onto the female body. Adam's fall from grace is attributed to Eve's sexuality. Christian women are required to dress modestly, but this standard is not equally applied to Christian men. Modesty with regard to body exposure is an important value that is a key indicator of religious conservatism.

During the Protestant Reformation of the sixteenth century, early leaders used dress as a symbol of piety. Fashionable, colorful dress and adornment were equated



with sensuality and pride, while somber dress showed the Christian's focus on salvation. For fundamentalist Christians (who evolved out of the Reformation) such as the Anabaptist groups (such as Amish, Mennonites, and Hutterites) who believe themselves to be uniquely separate from the larger society, dress is used to show that separation. In these groups, dress is often hyper-conservative or may even be a form of fossilized fashion.

### Sectarian Dress

Some of America's sectarian ethno-religious groups use fossilized fashion to separate themselves from the outside world. Notable among these are the Shakers, Amish, Hasidic Jews, Hutterites, and several conservative Mennonite groups. Fossilized fashion has been explained as a sudden "freezing" of fashion whereby a group continues to wear certain clothing long after it has gone out of style for the general population. This phenomenon has been explained as expressing dignity and high social status or the group's religious, old-fashioned, sectarian identity. Within certain ethno-religious groups, fossilized fashion is used in contemporary settings as a visual symbol of traditional gender roles for women; this generally occurs in societies that find change to be a threat.

Most of the conservative ethno-religious groups who wear fossilized fashion continue to wear clothing styles that were in use for the general population during the time their sect originated. For instance, the Amish separated from the larger Mennonite movement in the beginning of the seventeenth century; their garments in the early 2000s include full-fall trousers for men, and for women, dresses, bonnets, capes, aprons, and head coverings like their forebearers. Like the Amish, Shakers and the most conservative Mennonites in the United States continue to wear long dresses with aprons that provide an additional covering of the bust and stomach, again, like their forebearers. Other Mennonites dress in styles that were popular when their sect broke off from the larger Mennonite movement. Hasidic Jews have retained a complex code of dress for men that indicates a man's level of religiosity; these garments include particular hats, shoes, socks, and coats that are identifiable by members of their community. For Hasidic Jewish women, wigs are worn to cover their natural hair.

### Modesty and Female Sexuality in Dress

Among all of the major religions, modesty in women's dress is associated with gender norms; this is a major issue to religious groups. Gender issues are paramount in the dress codes of conservative religious groups since the control of female sexuality is often of great importance in patriarchal religious groups. The dress codes generally relate to modesty and require clothing to cover the contours of the female body. Additionally, some religious groups, particularly the most conservative Islamic, Anabaptist, and Jewish sects, also require that women's hair be covered as well.

As used by religious groups, the issue of modesty goes beyond the covering of the body in order to disguise female curves and secondary sexual characteristics; in the conservative strains of all of the major religions, dress codes also deal with the care and covering of women's hair as it is associated with women's sexuality (Scott, p. 33). Further complicating matters, dress codes are conflated with gender and power issues in religious groups. At the root of this issue is the control of female sexuality that is perceived to be necessary by some religious groups as a means to maintain social order.

An understanding of how dress works within religious groups calls attention to the complexity of meanings surrounding visible symbols such as dress, and sheds light on the ways that bodies can communicate social and religious values. The dress of religious groups can be used to facilitate social and ideological agendas. Clothing and personal adornment are used for establishing and maintaining personal and social identities, social hierarchies, definitions of deviance, and systems of control and power. As a consequence, then, dress within conservative religious groups is a symbol of the individual's commitment to the group while it also symbolizes the group's control over individual lives. For America's fundamentalist Christian groups, and the Anabaptist groups in particular, dress is particularly important with regard to its role in social control and in social change.

### Dress and Social Control

Dress is an immediate and visible indicator of how a person fits into his/her religious system. As a marker of identity, dress can be used to gauge the person's commitment to the group and to the religious value system. In many conservative groups, suppression of individuality is expected, in obedience to the rules of the religious organization. Several religious groups are also ethnically homogenous; these are referred to as ethno-religious groups (In the United States, some of these groups are the Amish, Mennonites, Hutterites, Hasidic Jews, Sikhs, and certain Islamic groups.) The conservative branches of ethno-religious groups frequently use clothing to simultaneously express ethnicity, gender norms, and level of religious involvement (religiosity). Through conformance to a strict religious value system, the most conservative of the religious social bodies exert control over their members' physical bodies. Since strict conformity is often equated with religiosity, compliance to strict codes of behavior is demanded. The internal body is subject to control by the religious culture, especially with regard to food and sex. The external body, however, is much more visibly restrained. Strict dress codes are enforced because dress is considered symbolic of religiosity. Clothing becomes a symbol of social control as it controls the external body. While a person's level of religiosity cannot be objectively perceived, symbols such as clothing are used as evidence that the member of the religious group is on the "right and true path."

Normative social control begins with personal social control through self-regulation, followed by informal social control. The member wants to fit into the group, and expresses role commitment by following the social norms, visibly expressed in the group's dress code. When the individual begins to offend, for example by wearing a garment that is too revealing of body contours, peers may disapprove and use subtle methods of informal control to pressure the individual to conform to the group norms. Finally, the threat that an offender introduces to the social order is managed through formal social control measures, such as disciplinary measures and expulsion administered by specialized agents, including ministers, rabbis, and other moral arbiters. Thus, norms are managed through social control to inhibit deviation and insure conformity to social norms at even the most-minute level.

Through symbolic devices, the physical body exhibits the normative values of the social body. Symbols, such as dress, help delineate the social unit and visually define its boundaries because they give nonverbal information about the individual. Unique dress attached to specific religious and cultural groups, then, can function to insulate group members from outsiders, while bonding the members to each other. Normative behavior within the culture re-affirms loyalty to the group and can be evidenced by the wearing of a uniform type of attire.

Within American culture there are specific ethno-religious groups that intentionally separate themselves from the rest of society and attempt to re-establish the small, face-to-face community. Many originated in Europe and moved to America when religious freedom was promised to immigrants. Shakers (Scott, p. 54), Mennonites, Hutterites (Scott, p. 72), and Amish (Scott, p. 87) are such groups. These groups are often perceived by the outside world as quite unusual, but that derives more from their deviant behaviors, visually manifest in dress, than from their religious differences from mainstream Christianity. An essential factor in ethno-religious groups, social control is significant in terms of the survival prospects of the group. Among orthodox Jews (Scott, p. 57) in Williamsburg New York, social control was achieved in ways remarkably similar to those used by the Amish and conservative Mennonites. The most important features included isolation from the external society; emphasis on conformity with status related to religiosity, symbolized by clothing status markers; a powerful clergy and rigorous sanctions to insure conformity to norms.

### Dress and Social Change

With changing social, political, and economic environments, even the most sectarian religious group has to contend with the impact of social change. Changes in dress often signal underlying changes in social roles as well as gender roles. Traditional gender roles can be marked by a particular form of dress where the roles are stable for long periods of time; when dress changes suddenly in

these groups, we can expect to find a change in gender roles. A good example is that of the change in the dress of Roman Catholic priests and nuns following the changes instituted by Vatican II in the 1960s. The changes were more pronounced for nuns as their roles within the Church dramatically changed; so too did their dress. Additionally, when roles are restrictive, we can expect to see a restriction in women's dress, in the form of either dress codes or physically restrictive clothing.

With immigration and colonization, clothing figured into the power imbalance between people of different religious backgrounds. As American missionaries in the nineteenth century encountered indigenous people, clothing became an issue almost immediately. Christian missionaries advanced their own ethnocentric perceptions of appropriate behavior and dress and, often through subtle coercion, guided the acculturation of indigenous peoples. Missionaries have often taken on the role of introducing western clothing to indigenous people as a means of "civilizing the natives." In some cases the transformation to western-styled clothing was part of the need of a religious group to dominate an indigenous culture. In other cases, a religious group immigrating to another country might also voluntarily make changes to their dress to facilitate their assimilation into the new society. One such example is that of Hawaii where missionaries objected to the indigenous dress of *kapa* skirts with no covering of the breasts. The missionaries required Hawaiians to wear western dress when at the missions; a particular garment called the *holoku* was created for Hawaiian women to wear. As Christianized Hawaiians became missionaries to Oceania, they brought the *holoku* into the islands, but the garment was known by different names outside of Hawaii.

Occasionally a reciprocal relationship occurred, in which the indigenous group more willingly took on the dress of the more powerful religious group. Strategic shifts from traditional dress to western dress among the Dakota tribes in Minnesota were somewhat voluntary. Similarly, the immigration of European Jews to America led to many Jews using dress as a means of blending into the larger society. On the other hand, Hasidic Jews chose to reflect their ethnicity by retaining fossilized fashion to intentionally separate them from the larger American culture. At the end of the twentieth century, some Christian and Roman Catholic churches began to incorporate indigenous textiles in their liturgical garments used in religious ceremonies. While this practice is seen primarily in missionary work of churches establishing missions in Africa and other locations such as the Philippines and South America. The use of ethnic textiles in African American churches has been a long-standing tradition that honors African heritage.

In conclusion, many religious groups have developed cultural norms with regard to dress. Dress codes, both formal and informal, exist as a means of showing group identity. Members of religious groups actively construct

their own lives and use dress symbolically to express religious beliefs, adaptation to social change, and the conformity to social norms and religious authority.

See also **Ecclesiastical Dress; Islamic Dress, Contemporary Jewish Dress.**

#### BIBLIOGRAPHY

- Arthur, Linda B. "Clothing Is a Window to the Soul: The Social Control of Women in a Holdeman Mennonite Community." *Journal of Mennonite Studies* 15 (1997): 11–29.
- , ed. *Religion, Dress and the Body*. Dress and the Body Series. Oxford: Berg, 1999.
- , ed. *Undressing Religion: Commitment and Conversion from a Cross-cultural Perspective*. Dress and Body Series. Oxford: Berg, 2000.
- Damhorst, Mary Lynn, Kimberly Miller, and Susan Michelman. *Meanings of Dress*. New York: Fairchild Publications, 1999.
- Goffman, Erving. *The Presentation of Self in Everyday Life*. Garden City, N.J.: Doubleday, 1959.
- Hostetler, John. *Amish Society*. Baltimore: Johns Hopkins Press, 1989.
- Poll, Solomon. *The Hasidic Community in Williamsburg*. New York: Glencoe Free Press, 1962.
- Scott, Stephen. *Why Do They Dress That Way?* Intercourse, Pa.: Good Books, 1986.

Linda B. Arthur

**RETAILING** Retailing consists of the set of business activities involved in selling products and services to consumers for their personal, family, or household use. Traditionally, a retailer serves as the last distribution channel that links manufacturers and consumers; however, in order to have control and exclusivity with their merchandise, most large retailers, such as Wal-Mart and the Gap, are vertically integrated and perform more than one set of activities in the distribution channel, such as both wholesaling and retailing activities or both manufacturing and retailing activities.

Retailing is a significant portion of world commerce. The world's 200 largest retailers generated \$2.14 trillion in sales during 2002 and captured 30 percent of worldwide sales. These firms represent a variety of nations and such categories as department stores, specialty stores, category killers, discount stores, mail order, and so forth. However, the top nine largest retailers are discount stores or category killers, indicating a consumer trend to demand low prices. With increasing globalization, 56 percent of the top 200 retailers operated in more than one country. Geographically, U.S. companies, including Wal-Mart, Home Depot, Kroger, and Target, represented 53 percent of the total sales from the top 200 global retailers. Wal-Mart was the world's largest retailer in terms of sales and number of stores in the world. It was more than three times the size of the second largest retailer, France's Carrefour.

Retailers are characterized by their retail mix, including the type of merchandise sold, the price of the merchandise, the variety and assortment of merchandise, and the level of customer service. Retailers are also categorized by a primary channel that they use to reach their customers such as store-based (specialty stores, department stores, discount stores) or nonstore (catalog, TV home shopping, Internet) retailers. However, successful retailers in the early 2000s are multichannel retailers that sell products or services through more than one channel. For example, retailers such as Wal-Mart (discount store) and Macy's (department store) use Internet and catalog channels, and utilize the unique feature provided by each channel.

#### Store-Based Retail Channel

Store-based retailers use brick-and-mortar stores as primary modes of operation. Major types of store-based retailers include department stores, specialty stores, category killers, discount stores, off-price stores, outlet stores, and boutiques.

**Department stores.** A department store is a large-scale retail unit that carries a wide and in-depth assortment of merchandise that is classified into section divisions by product type and brand name. While department stores originated in downtown areas of major cities in the nineteenth century, with the advent of car travel and suburban flight, they came to be located in regional malls and have a typical size of between 100,000 and 200,000 square feet (930–1860 square meters). Merchandise quality, pricing, and customer service (sales help, credit card, and delivery) range from average to quite high. Accordingly, department stores target consumers with household incomes that are at least average. Two types of department store are commonly noted: the full-line department store and the specialized department store. Full-line department stores such as Macy's and Marshall Field's carry both hard goods (such as furniture, housewares, and home electronics) and soft goods (apparel, accessories, and bedding). Except for Sears, most full-line department stores no longer offer major appliances. Specialized department stores or limited-line department stores restrict their inventories rather than carry full lines. For example, Saks Fifth Avenue, Neiman Marcus, and Nordstrom focus on apparel and wearable accessories and may not carry lines such as furniture and home electronics. Other merchants emphasize jewelry and home furnishings, such as Fortunoff.

In the early twenty-first century, the largest department stores in the United States in terms of sales include Sears (\$41.4 billion), JCPenny (\$32.3 billion), Federated Department Stores, which owns Macy's and Bloomingdale's among others (\$15.4 billion), and the May company, which owns such entities as Filene's, Lord & Taylor, and Famous-Barr (\$13.5 billion). With the fierce competition that arises from specialty stores and discount stores, department stores' market shares have fallen since



the mid-1990s. This decline has resulted in the reduced perceived-value for merchandise and services, unproductive selling space, low turnover merchandise, and fuzzy store images. A vast majority of department-store merchants in the early 2000s place great emphasis on soft goods and accessories, and less emphasis on hard goods.

**Specialty stores.** Specialty stores, also called limited-line stores, focus on selling one line of merchandise (such as jewelry) or serving one particular market (for example, maternity apparel). Specialty stores offer a narrow but deep assortment in the chosen category and tailor selection of products to a defined market segment. Specialty stores also feature a high level of customer service with knowledgeable sales personnel and customer service policies and intimate store size and atmosphere. A typical size of specialty stores is less than 8,000 square feet. Some specialty stores target affluent consumers with high price and upscale merchandise, whereas others target price-conscious consumers with discount merchandise. Popular product categories of specialty stores include apparel, personal care, home furnishings, jewelry, and sporting goods. The largest U.S. specialty stores in sales include GAP brands, which includes Gap, Baby Gap, Banana Republic, Gap Kids, and Old Navy (\$14.4 billion), and Limited brands, which includes The Limited, Henri Bendel, Intimate Brands, Lane Bryant, Lerner New York, Limited Too, Structure, and Express (\$8.4 billion).

**Category killers.** Also known as category specialist, category killers combine attributes of both specialty stores and discount stores because they feature a great breadth of assortment in one classification of merchandise (e.g., toys, electronics) and low prices. Because of the large volume of merchandise they require from suppliers, category killers can use their buying power to negotiate for low prices. Category killers provide consumers a warehouse environment with a typical store size of 50,000 to 120,000 square feet. Few sales people are available for assistance, but some category killers such as Office Depot (office supply) make knowledgeable salespeople available throughout the store to answer questions and make suggestions. The largest U.S. category killers in sales are Home Depot (\$58.2 billion), Lowe's (\$26.5 billion) and Best Buy (\$20.9 billion). Home Depot and Lowe's offer equipment and material used to make home improvements while Best Buy carries consumer electronics.

**Discount stores.** Discount stores offer customers broad assortments of merchandise, limited services, and low prices. Discount stores are also referred to full-line discount stores or discount department stores. For their commonly recognizable huge retail format, discount stores are also referred to as big box retailers. The biggest U.S. discount stores in terms of sales include Wal-Mart (\$246.5 billion), Target (\$42.7 billion), and Kmart (\$30.8 billion). In discount stores, customers can expect a similar range of product lines as those offered by full-line department stores, such as electronics, furniture, appliances,



**Gap store in New York City.** Specialty stores such as the vertically-integrated Gap limit their line to one area of merchandise. © GAIL MOONEY/CORBIS. REPRODUCED BY PERMISSION.

auto accessories, housewares, apparel, and wearable accessories, but these product lines in discount stores are less fashion-oriented than the product lines in department stores. Discount stores usually sell on only one floor rather than in a multifloored building, as traditional department stores do. A typical size of a discount store is between 60,000 and 80,000 square feet, but a supercenter that combines a discount store with a supermarket ranges from 150,000 to 220,000 square feet. Wal-Mart, Kmart, and Target all operate supercenters.

The maintenance of low prices and lean gross margin contribute to the fast growing business of discount stores. Due to intense competition from category killers, the trends for discount stores are to create attractive shopping environments, to provide consumers branded merchandise (such as Levi Strauss in Wal-Mart) or to develop licensing agreements (for example, Isaac Mizrahi in Target).

**Off-price stores.** Off-price stores offer an inconsistent assortment of fashion-oriented and brand-name products at low prices and limited customer services. The leading



**French retail supermarket.** France's Carrefour is the second largest retailer in the world, but its yearly sales are less than a third of the top retailer, Wal-Mart. AP/WIDE WORLD PHOTOS. REPRODUCED BY PERMISSION.

U.S. off-price retailers are T.J. Maxx and Marshalls (both owned by TJX), Ross Stores, and Burlington Coat Factory. Most merchandise is purchased opportunistically from manufacturers or from other retailers late in a selling season in exchange for low prices. This merchandise might be end-of-season excess inventory, unpopular styles and colors, returned merchandise, or irregulars. Due to this opportunistic buying practice, consumers cannot expect consistent offerings of merchandise. However, off-price stores appeal to budget and fashion-conscious consumers.

**Outlet stores.** Outlet stores are retailing units owned by manufacturers or by retailers that sell their leftover, low-quality, discontinued, irregular, out-of-season, or overstock merchandise at prices less than full retail prices of their regular stores. Manufacturer-owned outlet stores are frequently referred to as factory outlets. Outlet stores were traditionally located at or near the manufacturing plant. Contemporary outlet stores are typically clustered in outlet centers or malls and located far enough from key department stores or specialty stores to avoid jeopardizing sales at full retail prices. There are 14,000 U.S. outlet stores and many are located in one of the 260 outlet centers nationwide. These stores generated total sales of \$14.3 billion in 1999. Stores are characterized by few services, low rents, limited displays, and plain store fixtures, which reduce operating costs of the stores. Outlet retailing has been a popular way of disposing of unwanted merchandise by manufacturers and retailers. Even popular designers such as DKNY, Ralph Lauren, Calvin Klein,

and Gucci use outlet stores to dispose of leftover items. However, most outlets also have product made especially for them—which is not just unwanted merchandise but low-quality product produced specially for that market.

**Boutiques.** A boutique is a small store that concentrates on a specific and narrow market niche and features top-of-the-line merchandise. “Boutique” is a French term for little shop; the term was first used for small stores run by Paris couturiers. American boutique retailers include many top designers, such as Donna Karan, Calvin Klein, and Ralph Lauren. Boutiques offer high-priced, fashion-oriented merchandise and attract customers who want more sophisticated and individualized products than mass-produced goods. Boutiques cater to narrow, well-defined customer segments that usually consist of affluent men and women. Key to a boutique's attraction is its personal one-to-one service. Many designers are building flagship stores in their home country as well as in foreign markets.

### Nonstore Retail Channels

Nonstore retailers utilize their retail mix in environments that are not store-based. U.S. nonstore retailers generated a total of \$156 billion in 2001, accounting for roughly 5 percent of all U.S. retail sales. The major appeal of nonstore retailers is the convenience of shopping: shopping anytime and anywhere. Three major types of nonstore retailers include catalog retailers, electronic retailers (e-tailing), and television home-shopping retailers.

**Catalog retailers.** Catalog retailers promote products by mailing merchandise directly to a target market and process sales transactions using the mail, telephone, or fax, or Internet. Many catalog retailers embrace the Internet. When customers are mailed a catalog from the retailer, they either can order products by telephone or mail, or through the retailer's Web site. According to *Catalog Age* (2001), the most popular catalogers recognized by U.S. consumers include J.C. Penny, Land's End, L.L. Bean, and Sears.

**Television home-shopping retailers.** Television home-shopping retailers use a program to promote and demonstrate their merchandise and process transaction over the telephone or Internet or through the mail. The two biggest home shopping retailers are QVC (“Quality, Value, Convenience”) and HSN (Home Shopping Network). The best-selling merchandise of TV home shopping is inexpensive jewelry. Other categories include apparel, cosmetics, and exercise equipment.

**E-tailers.** The fastest-growing form of nonstore retailing is electronic retailing (e-tailing). Electronic retailers interact with customers and provide products or services for sale using the Internet. During the last five years of the 1990s, electronic retailing had a rapid growth with the creation of more than 10,000 entrepreneurial electronic retailing ventures. However, a large number of electronic retailers, especially electronic retailers that

only used the Internet for selling products or services, have gone out of business since the Internet bubble burst in 2000. In 2001, U.S. electronic retailers generated about \$50 billion in sales, accounting for 1.5 percent of total retail sales. The best-selling merchandise online includes computers and electronics, sporting goods, books and CDs, toys, and apparel. Due to continued consumer interest in shopping using the Internet, store-based and catalog retailers have also begun to sell their merchandise using the Internet.

See also **Department Store; Fashion Marketing and Merchandising; Shopping.**

#### BIBLIOGRAPHY

Berman, Barry, and Joel R. Evans. *Retail Management*. 9th ed. Upper Saddle River, N.J.: Prentice Hall, 2004.

Levy, Michael, and Barton A. Weitz. *Retailing Management*. 5th ed. New York: McGraw-Hill/Irwin, 2004.

#### Internet Resources

"Catalog Age Top Ten." *Catalog Age* June 2001. Available from <[http://catalogagemag.com/ar/marketing\\_catalog\\_age\\_top\\_2](http://catalogagemag.com/ar/marketing_catalog_age_top_2)>.

"Research Data: Outlet Industry Data." *Value Retail News* (2003). Available from <[http://www.valueretailnews.com/research/research\\_index.htm](http://www.valueretailnews.com/research/research_index.htm)>.

"Top 100 retailers." *Stores* July 2003. Available from <<http://www.stores.org/archives/TopRetailers.asp?year=2003>>.

"2003 Global Power of Retailing." *Stores* January 2003. Available from <<http://www.stores.org>>.

*Seung-Eun Lee*

**RETRO STYLES** The fashion meaning of retro, first applied to clothes in the 1970s, refers to styles that are either copied or adapted from earlier periods. The retro reference was coined by London designers, and soon became a common coin throughout the fashion world. Thus the prefix for backward became a catchword for fashion in retrograde, fashion in retrogression—or retrospective fashion. While the word retro was "new" in the style context, the concept of born-again fashion was not.

Fashion has often taken the past as inspiration. In the 1910s, Paul Poiret's fashions were inspired by the *Directoire*, the style of French design in the mid-1790s, which itself used Greco-Roman forms and Egyptian motifs.

The Neoclassicism of the 1790s alluded to the political heritage of Greek democracy and the Roman Republic, while later Egyptian motifs memorialized Napoleon's conquest of Egypt. Poiret's Neoclassicism, however, seems to have had no political significance, although it certainly emphasized physical freedom. In the 1930s, French fashion surrealists were influenced by the second empire of Louis Napoleon (1852–1870).

The mannish styles of World War II gave way in 1947 to Christian Dior's New Look. His wasp-waisted,

hip-padded, full-skirted silhouette represented a release from wartime austerity, and was in itself a homage to his mother and her *fin de siècle* finery. Dior's fitted jacked segued into the 1970s and 1980s, becoming a template for designers such as Claude Montana, Thierry Mugler, Azzedine Alaïa, and Christian Lacroix, all of whom grew up in the Dior oeuvre. The full, petticoated skirts that marked the 1950s (which were in many respects a continuation of the New Look) reflected a societal return to pre-World War II gender stereotypes and Cold War social conservatism.

The 1960s relaunched aspects of the 1920s, the two decades sharing the same spirit of youth and anarchy—although sixties fashion originated on the streets of London (Mary Quant and the miniskirted Mods) instead of the salons of Paris. Perhaps because the 1960s symbolized the Youthquake and the mini, they have been resuscitated more than any other decade, most obviously every time designers show thigh-high miniskirts.

As the twenty-first century progresses, the 1970s, especially the mid-1970s, which were nostalgic for the 1930s, have been a favorite playback by designers in their forties. The shoulder-padded 1980s, which owe a big debt to the 1940s, were first returned to by designers in their thirties. And the minimalist, less-is-more 1990s are waiting to be rehashed when designers born in that decade reach their twenties. It seems that designers are inspired by the period when they first became interested in fashion—usually during their teens or twenties—or the period in which their design heroes lived. (One reason the 1960s have had so many sequels is that the designers of that decade were legends whose work was photographed, cataloged, and exhibited in museums as perhaps no other until that time.)

At the beginning of the twenty-first century, a new fashion amalgam appeared, one based on borrowing from other times, therefore retro, but one tweaked with "newness." This idea of taking bits of someone else's original work and either copying it or mixing it and then calling it one's own is also seen in other art forms. In the art world, it is called "appropriation." In music, it is "sampling." In the movies, it is sequels or "part twos." And in fashion, as in food, it is known as fusion. Another favorite expression for retro styles is called referencing.

In fusion, the originality consisted in how the old was made "new." For example, the original space-age designs worn by Paris designer André Courrèges's moon maidens were worn with low-heeled, calf-high, white patent-leather boots. In the fused versions, Courrèges's A-line jumpers were subverted with high heels or combat boots, and some of the minis were layered over evening dresses or paired with leggings.

To this day, there are designers who plunder the past verbatim, seam-for-seam, stitch-for-stitch, line-for-line. Some credit the originals. To his credit, the late Bill Blass, in his book, *Bare Blass*, edited by the *New York Times's*



fashion critic Cathy Horyn, writes about First Lady Nancy Reagan wearing his gown to the Washington gala the night before Ronald Reagan's first inauguration: "...she wore a black velvet dress of mine. Which *Women's Wear* said was a knock-off of Saint Laurent's. Which indeed it was." Other designers cite no provenance. Those who do not are usually not called for copying for three reasons. First, few seem to care if a designer such as Nicolas Ghesquiere of Balenciaga calls a design by Kaisik Wong his own, even when confronted with visual proof. Appropriation is now considered not just acceptable, but expected. Second, few magazine editors can risk jeopardizing the loss of advertising pages if they offend the big-advertising designer by accusing him of stealing—whoops, appropriation. And third, there are not too many fashion journalists in the media mix of the early 2000s who would recognize a purloined design if they saw one.

One of the reasons retro styles became a fashion byword during the late twentieth and early twenty-first centuries can be attributed to the rage for vintage clothes. After almost a decade of simple, spare, less-is-more fashion, many women sought relief from the minimalist mode at swap meets, thrift shops, and vintage boutiques, where the old looked suddenly newer than the new.

It's the nature of the fashion beast to feed on the past. This apologia by TV host/designer Isaac Mizrahi hits the mark. He says that to complain about revivals of clothes from other decades is to complain about chicken. "A good classic recipe for *poulet* has existed for centuries, yet people still make chicken dishes. They may change some of the spices, but the basis is still chicken. In the same way, a classic dress from any period attained classic status because it is a good, time-tested design that is worthy of being modernized with new fabrics and new accessories. In other words, you just change the recipe to suit modern tastes."

See also **Fashion, Historical Studies of.**

Marylou Luther

**RHODES, ZANDRA** Zandra Lindsey Rhodes was born in 1940 in Kent, England. Her first fashion influence was her mother, who was a fitter at the House of Worth in Paris before she became a senior lecturer in fashion at Medway College of Art. Zandra Rhodes subsequently studied textile design at the same college for two years, before going on to the Royal College of Art to extend her studies. She graduated with first class honors in 1964 from the Royal College of Art at a time when design creativity was at a premium and London was the center of avant-garde fashion. After leaving college she designed for a print studio she had established with Alexander McIntyre, until teaming up with Sylvia Ayton, a fellow graduate, to produce a range of garments in which Rhodes was able to explore innovative ideas like her famous lipstick print. In 1968 the two decided to open their

own boutique, the Fulham Road Clothes Shop, selling garments designed by Sylvia Ayton and made up in Zandra Rhodes's printed fabrics. Among their most innovative ideas were tattoo print transfers and paper dresses.

### Freelance Designer

Although commercially successful, lack of financial acumen closed the business, and Rhodes went on to become a freelance designer, producing her first solo collection in 1969. She was encouraged by a successful visit to New York, where she sold work to the department store Henri Bendel, but it was difficult to convince buyers from the big British department stores to stock avant-garde designers. Marit Allen, then editor of "Young Ideas" in *Vogue*, showed Rhodes's clothes in the pages of the magazine, even though they had no retail outlet at the time. The ploy persuaded retailers that there was a market for innovative design, and Allen introduced Rhodes's clothes to the London store Fortnum and Mason.

### Evening Wear

Renowned primarily for her evening wear, Zandra Rhodes produced instantly identifiable garments that reflected the early 1970s preoccupation with a floating, unreconstructed silhouette. During this period printed textiles were an intrinsic element of fashion, and together with Celia Birtwell and Bernard Nevill, she was responsible for the multipatterned and colorful look that defined the era. Her inspiration is rooted in the use of autographic sketchbooks, where she researched primary sources such as organic matter and transformed the initial drawings into her signature style: abstract, loose, screen-printed, flowing forms that play with scale and vibrant color combinations, all handmade and often including her signature "squiggle." Prints occasionally include handwritten text; one of her pieces for the Fulham Road Clothes Shop was a blouse printed with the name of the shop on the collar and cuffs, an early use of the logo. Zandra Rhodes was one of the first designers to use the street-style punk look, reversing seams and using safety pins and tears for a dress in the 1977 Conceptual Chic collection. Her personal style has always reflected the flamboyant quality of her clothes. She accessorized her outfits with outsized jewelry and sported green, then pink hair, with emphatic eye makeup and multicolored face paint.

### Construction and Features

The construction of Rhodes's garments is very much inspired by the cut and form of vernacular dress. She is attracted to the simplicity of the shapes that are both functional and also use the whole piece of fabric. She notes:

I had come across the actual chronicle of costume, the definitive book by Max Tilke on *Costume Patterns and Designs*, its simple and detailed pages showing the cut and form of traditional clothing throughout the world. Details of armholes, wrapped trousers, em-



**Zandra Rhodes.** British fashion designer Zandra Rhodes reclines in a garden. She is wearing a print dress, a style she helped bring to prominence in the 1970s. © ERIC CRICHTON/CORBIS. REPRODUCED BY PERMISSION.

broidered waistcoats and flat, worked-out-kaftan and peasant shapes were all explained with the simplicity of a gardening book (Rhodes and Knight, p. 37).

These garment shapes maximize the effect of the print, relying on layers, gathers, smocking, and shirring and often featuring handkerchief points to create the silhouette. The clothes are engineered to accommodate the placement of the prints, rather than cut from continuous, repetitive yardage. For this reason Rhodes's garments remain outside the seasonal transitions of mainstream fashion.

Rhodes went on to design handmade, elaborate, feminine, evening dresses using her distinctive prints. Her clients included the late Princess of Wales and Princess Anne, who wore a Rhodes dress in her engagement portrait. During the minimalistic 1990s, her fantasy gowns, embellished with beads, sequins, and feathers, found less favor with the fashion press, but with the revival of vintage fashion in the early 2000s, her clothes are once again sought after.

### Recognition

Zandra Rhodes has been the recipient of many academic and professional awards over the years, including honorary doctorates from the Royal College of Art and other universities in both Great Britain and the United States. She was made a Commander of the British Empire in 1997 in recognition of her services to the fashion and tex-

tile industry. Early in the twenty-first century, Rhodes was spending some of her time in San Diego, California, and it was here that she was invited to design the costumes for the San Diego Opera's production of *The Magic Flute* in 2001, garments that received great critical acclaim.

### Diversification

Rhodes has diversified her design business into household linens and textiles, glassware, linens, cushions, throws, rugs, and screens. In collaboration with the artist David Humphries, she fashioned a number of terrazzo designs, such as the Global Plaza at Harbourside in Sydney, Australia, and the Del Mar House Terrazzo project in California, for which she was given an honor award by the National Terrazzo and Mosaic Association in 1998.

In 2003 Zandra Rhodes realized a long-held ambition to open a museum. The strikingly colored frontage of her Fashion and Textile Museum has become one of London's landmarks. Sited in Bermondsey on the south bank of the river Thames, it was designed by the Mexican architect Ricardo Legoreta. As a select showcase for contemporary and vintage fashion and textile design, the museum is intended to provide an accessible archive and resource center. It also seeks to generate discourse on design by providing a forum for debate and student activity. The inaugural exhibition, *My Favourite Dress*, included the work of seventy of the most internationally renowned contemporary designers, including John Galiano, Yohji Yamamoto, Julien MacDonald, Antonio Berardi, Roland Mouret, and Sophia Kokosalaki.

See also **Diana, Princess of Wales; Evening Dress; Fashion Museums and Collections.**

### BIBLIOGRAPHY

- Rhodes, Zandra, and Anne Knight. *The Art of Zandra Rhodes*. London: Cape, 1984.
- Steele, Valerie. *Women of Fashion: Twentieth Century Designers*. New York: Rizzoli International, 1991.

Marnie Fogg

**RIBBON** The term "ribbon" refers to narrow loom-woven strips of cloth, often with a visible selvage on each side that helps them to maintain their form. Ribbons can be made of any fiber and are usually woven in satin, plain, gauze, twill, and velvet weaves. The origins of the term "ribbon" and its earlier forms, ruban or riband, are obscure, but they may be Teutonic and a compound of the word "band"—the ancestor of the modern day ribbon. As early as the Neolithic period, people wove very narrow, dense, often utilitarian strips of fabric on small portable looms. Impressions of warp-faced plain weave bands dating back to 6000 B.C.E. were excavated from the Turkish archaeological site of Çatal Hüyük. While their purpose was primarily functional, some evidence suggests that bands also could be used for more flirtatious and decora-



**Naval ribbons and medals.** In military institutions ribbons covering metal pins serve as indicators of award and rank. Ribbons are also used to attach medals to the uniforms of soldiers.  
© YOGI, INC./CORBIS. REPRODUCED BY PERMISSION.

tive purposes. Elizabeth Wayland Barber has suggested that dancers waved strips of fabric while performing beginning in the Middle Bronze Age. Evidence exists that in the Aegean cultures of 2000 through 1200 B.C.E., specialized weavers used a warp-weighted vertical loom to weave decorative edgings and bands to ornament and trim garments.

In Europe, the weaving of lightweight ribbons as opposed to the sturdy, warp-faced bands of antiquity probably began as soon as the horizontal loom was introduced during the eleventh century. Lightweight ribbons were not unknown, however; archaeologists working in London uncovered several plain weave ribbons of unspun, undegummed silk, which were probably imported from the East.

References to ribbons occur with increasing frequency during the fourteenth and fifteenth centuries as more tailored clothing developed and ribbons with aiglets (metal points) at each end were used to lace garments together. Ribbons also trimmed garments as they had in the past, encircled waists as girdles, and were worn in the hair. London archaeologists excavated ribbons of spun silk (probably woven locally) found in digs dating to the

fourteenth and early fifteenth centuries. While ribbons continued to be an aspect of fashionable dress throughout the Middle Ages and Renaissance, they did not become a focus of fashion until the seventeenth century after a loom was invented that could weave more than one ribbon at a time. This new loom allowed multiple ribbons to be woven at once by providing a separate warp beam and shuttle for each ribbon. An Italian abbé, Lancellotti, was the first to write about such a loom, which he said was invented in Danzig around 1530. He also wrote that the loom so threatened traditional ribbon weavers that it was destroyed and the inventor secretly strangled or drowned. The new loom was not totally lost, for it appears again in Leiden by 1604 and in London by 1610. However, it was in France that the use of ribbons took hold when Louis XIV turned them into a fashion obsession.

The city of Paris was well known for its ribbons, as were the cities of Saint-Étienne and Saint-Chamond, where ribbons were woven as early as the beginning of the fourteenth century. Charles VII published the first statutes of the master tissutiers and Rubanniers of Paris in 1403. Statutes were again published in 1524 and in 1585, when the rubanniers were assigned their own guild. Ribbon weavers during this period worked on small looms that were light, compact, and sat on tabletops. Men, women, and even children easily wove on these looms, producing one ribbon at a time, and small workshops predominated. When the new ribbon loom was introduced during the seventeenth century, it revolutionized the trades and, as in Danzig, at first encountered resistance among the ribbon weavers of France.

Despite the reluctance of the French ribbon weavers to use the new loom, Louis XIV's finance minister Jean-Baptiste Colbert strongly encouraged its acceptance and, because the king adopted ribbons as an important element of fashionable dress, the trade flourished. Ribbons of silk and gold and silver thread were woven in many different structures, including plain weave taffetas, satin, and velvets. A wide range of brilliant dyes was employed to color the ribbons, including cerulean blue, yellow, and a variety of reds such as crimson, scarlet, cherry, and Louis XIV's favorite *couleur de feu*, or flame. Courtiers attached ribbons to hats, sword handles, shoes, sleeves, around the knees, and even to the lower bodice front, where yards of ribbon loops emphasized the wearer's masculinity. Diana de Marly writes in her book on fashion during the reign of Louis XIV that the Marquis de Louvois and the Marquis de Villeroy would shut themselves up in a chamber for days discussing the best placement for a ribbon on a suit.

By the end of the seventeenth century, ribbons began to lose their popularity with men as the more somber three-piece suit came into favor. Women continued to wear ribbons, but not to the extent that they were worn during the previous decade. By the middle of the eighteenth century, ribbons again came to the forefront of women's fashion when dresses were trimmed with silk-



ribbon bows. Stomacher trims, known in French as the *echelle* and used to close the front of the dress, had horizontal rows of large bows down the front. Bows further decorated the elbows and were often worn around the neck. By the end of the eighteenth century, dressmakers and milliners began to use ribbons in increasing quantities as fashion's focus turned to the trimmings of dresses and hats.

Fashion's growing interest in ribbons increased during the early nineteenth century as the jacquard mechanism was adapted for use with ribbons looms. Weavers wove intricately patterned silk ribbons that became extremely fashionable during the nineteenth century. These ribbons trimmed the lavish and large bonnets of the 1820s and 1830s. The town of Saint-Étienne adapted itself to these new developments and became a leading center in the ribbon trade, specializing in weaving floral patterned ribbons. Saint-Étienne also specialized in weaving the ribbons that played an increasingly important role in national dress, especially the dress of French women from Brittany, Savoy, Alsace, and Provence. Ribbons ornamented bonnets, caps, aprons, blouses, and skirts, and their color could be used to indicate the religious beliefs of the wearer, as in Alsace, where a red ribbon indicated a Protestant background and black, a Catholic one.

Fashionable dressmakers and milliners continued to use ribbons in their work throughout the nineteenth and even twentieth centuries, although not as frequently as in the past. During some periods ribbons enjoyed more popularity than others, such as the mid-nineteenth century, when trimmings on dresses became increasingly fashionable and ribbons edged flounces and were folded and braided to create complex trims. Ribbons again took on importance during the years between 1910 and 1920, when they were formed into flowers and trimmed elaborate evening dresses, known as *robes de styles*. Couturiers such as Lucile and the Callot sisters were well known for these gowns. Ribbons played less of a role in fashionable dress during the rest of the twentieth century, but they did not escape the notice of several designers. Charles James, Karl Lagerfeld, and James Galanos all designed dresses composed entirely of ribbons stitched together to form a cloth.

While the jacquard was adapted to create ribbons patterned with complex floral designs for fashionable and national dress, novelty ribbons and pictures also were woven with extremely detailed imagery that resembled the work of etchers and engravers. The weavers showed many of these pictures and ribbons at international expositions, trumpeting the jacquard's technical achievements. The ribbons often were woven to commemorate special occasions or events, such as elections and political or historic anniversaries, and they point to another aspect of the use of ribbons, to honor and remember.

It is impossible to say when ribbons took on significance outside of their role in dress, but the *Oxford English Dictionary* indicates that as early as the sixteenth



**Dress with a ribbon bodice.** This 2002 Benjamin Cho dress features a bodice made entirely of ribbons. AP/WIDE WORLD PHOTOS. REPRODUCED WITH PERMISSION.

century they were given between men and women as favors and that by the seventeenth century wide blue ribbons were worn across the chest by members of the Order of the Garter, the highest honor bestowed by the British ruler. Ribbons were also used to attached medals to the chests of honored military men, and today small pins covered with ribbons patterned in a variety of stripes are worn on American military uniforms in place of the medals. The use of blue ribbons and red ribbons as first and second prizes in competition appears to have begun in the late nineteenth century.

Ribbons also served to commemorate the dead. Mourners wore black armbands and hatbands, while narrow black "ribbons of love" decorated the caps and blankets of babies. The use of ribbons as a token of remembrance took on particular significance in the later part of the twentieth century. In 1981, Americans beaded their trees with yards of yellow ribbons as a sign of remembrance and to welcome home American hostages taken in Iran. While many believed the custom started during the Civil War as a way to welcome home returning soldiers, in reality, Penne Laingen, the wife of

one of the Iran hostages who began the tradition in 1979, was inspired by the act of another woman. In 1975, Gail Magruder festooned her front porch with yellow ribbons to welcome home her husband, Jeb Stuart Magruder, who had recently been released from prison after his conviction during the Watergate investigations. The number one single of 1973, "Tie a Yellow Ribbon Round the Ole Oak Tree," sung by Tony Orlando and Dawn, inspired Gail Magruder's act. The song was in turn inspired by the legend of a man released from prison who told his wife to tie a yellow ribbon on an old oak tree if she welcomed him back. Yellow ribbons again appeared in Americans' front yards after the first Persian Gulf War of 1991 to greet returning soldiers.

The symbolic use of ribbons increased toward the end of the twentieth century, and the wearing of a small colored ribbon pinned to one's clothing came to indicate a sympathy toward one cause or another. In 1990, the art activism group Visual AIDS introduced the custom of wearing a small loop of red ribbon as an international symbol of AIDS awareness. A small pink bow is indicative of an awareness and support of breast cancer research.

While ribbons are still manufactured and can be found trimming hats and lingerie, they are no longer an important element of fashion. Their place as commemorative tokens and in the work of crafters has ensured the continued production of ribbons; however, manufacturing methods have evolved to make them cheaper to produce. Ribbons woven on a loom are more rarely produced today, and cut-edge or fused ribbons are more common. Thermoplastic fibers woven in satin or plain weave taffeta are slit in the desired width with a heated cutting tool that fuses and seals the edges of the ribbon—a far distant cousin to the luxurious silk, silver, and gold ribbons of the seventeenth century.

*See also* Callot Sisters; Loom; Lucile; Politics and Fashion; Silk; Trimmings.

#### BIBLIOGRAPHY

- Barber, Elizabeth Wayland. *Prehistoric Textiles*. Princeton, N.J.: Princeton University Press, 1991.
- de Marly, Diana. *Louis XIV & Versailles*. New York: Holmes and Meier, 1987.
- Kerridge, Eric. *Textile Manufactures in Early Modern England*. Manchester, U.K., and Dover, N.H.: Manchester University Press, 1985.
- Musée National des Arts et Traditions Populaires. *Rubans et Galons*. Paris: Musée National des Arts et Traditions Populaires, 1992.

*Pamela A. Parmal*

**RINGS** The circular form surrounding the finger without beginning or end was subject to numerous beliefs and superstitions. Even if the finger ring initially served a dec-

orative purpose, of all types of jewelry, it has possibly the most personal of meanings for the wearer. Finger rings were worn as a sign of wealth, power, and love and given for special occasions marking various stages of the wearer's life. Rarely can the wearer be identified, yet the choice of symbols, materials, or stones of a ring often identify the function or occasion to which a finger ring adorned the wearer's hand, and tells a personal story.

The ring is a very compact form of jewel, with its dimensions determined by the size of the finger and thus confining the maker to work in a miniature scale. Despite the rigidly restricted form based on the finger, the diversity of the designs throughout the millennia is proof of the wealth of artistic imagination. The small dimensions are also challenging for the jewelry historian, who is often confronted with only minute details to give a precise date to a piece. Unlike any other type of jewelry, the shape of the finger ring has never been dependent on any dress fashions, yet in every civilization their designs mirror the heritage and contemporary art styles of the period or region.

Pictorial images illustrating how rings were worn on the hand are rare in antiquity, either on mummies of Ancient Egypt or tomb sculptures of the Etruscan and Roman periods, more revealing though are portraits of men, women, and children in Western Art from the fifteenth century onward.

Finger rings may have existed since early humankind, yet many of the organic materials used in the prehistoric era, such as bones, shells and plants, would not have survived. Earliest known examples go back to the Sumerian civilization in Mesopotamia of the third millennium B.C.E. Decorative examples of gold with inlaid lapis-lazuli or carnelian are very rare; more common are the stamp and cylinder seals of the Ancient Near East, generally made of stone with gold caps and swivel hoops, from which the signet ring, the oldest form of finger ring originated. The early signets had a distinctive function, at a time when the art of writing was known to few; they served as a guarantee of authenticity or ownership, and were used for trade as well as for legal transactions. While wax seals are generally a thing of the past, as late as the 2000s the signet ring remains unchanged.

In the Middle Kingdom of Ancient Egypt in the second millennium B.C.E., the cylinder seal ring developed into a form that was to dominate Egyptian finger rings for many centuries, that of the scarab, the dung beetle carved in gemstones, such as lapis-lazuli, obsidian, jasper, faience or glass imitations, with a drill hole and either a cord or gold wire running through the beetle and encircling the finger. The hoops and settings became more elaborate in their design, yet the basic shape remained the same: the scarab could be swiveled on its mount to use the engraved underside for sealing, and the beetle was worn as a decorative ornament on the finger. A scarab with the engraved name of its owner, such as that of the

pharaoh or priest, was worn for its magical qualities as a good-luck charm.

The scarab on the revolving bezel was a ring type copied by the Phoenicians, Etruscans, and Greeks, as well as the heavy gold stirrup rings of Ancient Egypt with cartouche-shaped bezels. These were refined in Ancient Greece, and the shapes became more varied and the decorations intricate. The bezel in either gold, silver, bronze, or set with a gemstone, illustrated mythological scenes or beasts transmitting the attributes of deities or the diligence and strength of the animals to the wearer. During the Hellenistic period, rings became fancy, the gold intricate, and settings for stones more elaborate, and the function tended to be decorative.

With the love for gemstones and their availability through newly opened trade routes, the art of cutting gems evolved in ancient Greece and later in ancient Rome, where a stone became an essential element of the ring. The motifs incised as intaglios or carved in relief showed apart from mythological figures, subjects from literature, theater, and everyday life to assist or mark momentous occasions or provide good luck. During the early Roman period, iron rings were common among all classes, and later were only worn by slaves and soldiers, and as betrothal rings. Even though the Greeks had love rings, the Romans appear to be the first to have introduced the betrothal ring given by the prospective husband as a warranty or pledge of marriage. The early examples were circles made of iron. In the second and third centuries C.E. with the ever-expanding Roman Empire and newly acquired wealth, social structures had changed, and this was very much reflected in the bold proportions and designs of heavy gold betrothal rings with devices such as Hercules knots (love knots), the *dextrarum iunctio* showing two right hands clasped together (both motifs continued into the nineteenth century), and other erotic symbols. The ring became a display of luxury and status, even remarked on in contemporary accounts. By the Roman period, jewelry was accessible to a wider range of social classes, but with the new wealth, restrictions were imposed as to who was allowed to wear gold or silver.

The early Christians used late Roman ring shapes, mainly in gilt bronze or silver, and replaced the pagan divinities and other heathen symbols with Christian motifs as a sign of their allegiance to the new faith; these included the Chi-Rho monogram of Christ, a fish, a dolphin and Agnus Dei. The Byzantines, in turn, adopted in silver and gold with niello, the Christian ring forms and symbols. The iconography, however, was expanded to include images of the Virgin and Child, numerous saints, crosses with coded personal monograms of the owners and scenes—such as the marriage ritual with the couple being blessed by Christ—and also sacred Greek inscriptions. Splendid gold rings from the Byzantine period, with high bezels in ornately pierced gold set with sapphires, garnets, and pearls, also exist. These decora-

tive specimens, which exemplify the goldsmithing art and the technique of inlaying stones of the Byzantines, influenced the numerous tribes crossing Europe during the early Middle Ages.

From the twelfth century onward, while the wearing of finger rings was not restricted to any social classes, the use of gold or certain gemstones was limited by each country according to its sumptuary laws. Many pieces have survived through hoards all over Europe. While it is fascinating to observe the international style of many medieval ring types, it is almost impossible to determine the place of manufacture without knowledge of the provenance. Design ideas often with high constructed bezels appear to have traveled with the trade of gemstones from the Orient. Diamonds, sapphires, rubies, spinels, and amethysts in cabochon cut were favored by the church clerics as a sign of rank. Devotional images, such as various cross forms, the Virgin Mary, and symbolic beasts such as the Pelican and her Piety, often complemented Greek and Latin inscriptions to be worn by the devout. Figures of saints or relics in rings were thought to have protective or curative powers against cramps, fevers, epilepsy, or illnesses of the eyes, kidneys, or whatever ailment the wearer had.

Rings with amorous symbols and messages of love, often in French as the international language of the courts, were popular during the medieval and Renaissance periods. They were worn as signs of affection in courtship and later in marriage. One of the most widespread is the *fede* ring (Italian for “trust”) with two right hands in gold clasped to indicate the pledge of troth, known in Roman times and continued well into the nineteenth century. Rubies and diamonds in table-cut were traditionally symbolic of love and constancy and only affordable by the wealthy. Gimmel rings (*gemellus* is Latin for “twin”) with twin bezels served as settings for this traditional combination, and to underline the significance, figures of lovers or hearts united were combined with inscriptions, such as “What God hath joined together, let man not put asunder” (Matthew 19:6) in Latin or the language of the country of origin. The exchange of marriage rings during the ceremony instead of giving a ring as a pledge of betrothal varied from country to country. The engagement ring, as is known today, was more of an invention of the nineteenth century with the diamond cluster rings.

Whether in gilt bronze, silver, or heavy gold, or even in the splendor of engraved rock crystal with colored foils beneath the heraldry, the signet became a status symbol for all. Even the merchant, gaining ever more influence from the fifteenth century onward, copied the aristocratic codes and practice, and wore a family coat of arms, merchant’s mark, or guild rings, taking pride in his profession and position in society.

In the sixteenth and seventeenth centuries, signet rings occasionally had a double-sided bezel, which could



be swiveled to include a *memento mori* motif—a death's head, miniature skeleton, or hourglass—and symbols of decay with creeping things, such as worms, reminding people of their transience and preparing them for death.

Mourning rings were popular from about the fifteenth to nineteenth centuries, in particular during the baroque period and eighteenth century. Memorial rings with commemorative inscriptions and portraits of the deceased became fashionable, and mourning rings were given at funerals as a token of remembrance; these were black or dark blue in combination with white enamel surrounding the name of the deceased person and their birth and death dates. In the late eighteenth century, memorial rings reached a peak together with the ritual of mourning. Large elaborate bezels illustrated death through symbols such as the broken column, the obelisk, with the most popular being the funerary urn derived from antiquity. These were often accompanied by weeping willows, cypresses, faithful dogs, and lamenting women in classical drapery, either diamond-studded or made of the hair of the deceased, against a dark blue enamel or glass over an engine-turned background.

In contrast to this, the eighteenth century showed an abundance of fancy rings, with hearts entwined in rubies and diamonds, billing doves, love knots, flowers tied with ribbons or filling a basket, and other themes of nature, masquerade or games in polychrome choice of stones. The decorative feature of the ring culminated in the multilayered bezels and clusters of stones in rose-cut and other fancy cuts that became stylish in the eighteenth century, which continues to be popular in the early twenty-first century.

In the nineteenth century, the ring was characterized by romantic iconography with symbols of sentiment and inscriptions: the language of flowers, such as forget-me-nots for memory; from the animal world, snakes as a sign of eternity, butterflies for vanity, or miniature envelopes and purses enclosing love declarations; and the language of stones, such as the turquoise serving as a token of friendship and affection.

As historical portraits of rulers or heroes show, rings were worn as a sign of political allegiance, but they also depicted scenes of historic political events such as the French Revolution or the Napoleonic Wars. Rings also signify allegiance to social groups and institutions.

A small, yet fascinating group of rings exist that are used for specific functions such as the archer's ring in antiquity, the rosary ring for saying prayers, the pipe-stopper ring, sundial or watch rings, squirt rings, vinaigrettes, or those with some scientific novelty such as a spy glass or miniature photograph.

Throughout the millennia of its history, the ring with bezel, shank, and hoop encircled the finger with a round, oval, or derivative shape. In the early twentieth century, the ring had undergone a radical change when, in the art nouveau period, the bezel together with the

hoop became a freestanding piece of sculpture that challenged all traditional forms. The foundations were laid for the artist jeweler of the twentieth and twenty-first centuries who creates rings as free art forms. The materials and designs used for rings in the second half of the twentieth century broke all boundaries, and precious metals were combined with nonprecious materials of the period, such as plastics, paper, and everything hitherto unconventional.

See also **Bracelets; Brooches and Pins; Jewelry; Necklaces and Pendants.**

#### BIBLIOGRAPHY

- Chadour, Anna Beatriz. *Rings: The Alice and Louis Koch Collection*. Leeds, England: Maney Publishing, 1994.
- Cutsem, Anne van. *A World of Rings: Africa, Asia, America*. Milan: Skira Editore, 2000.
- Dalton, O. M. *Catalogue of Finger Rings, Early Christian, Byzantine, Teutonic, Medieval and Later*. London: British Museum, 1912.
- Kunz, George Frederick. *Rings for the Finger*. New York: Dover Publications, 1973. Reprint of original edition published in 1917.
- Marshall, Frederick Henry. *Catalogue of Finger Rings: Greek, Etruscan and Roman in the Department of Antiquities, British Museum*. London: British Museum, 1968. Reprint of original edition published in 1907.
- Oman, Charles C. *Victoria and Albert Museum, Catalogue of Rings*. Ipswich, U.K.: Anglia Publishing, 1993. Reprint of original edition published in 1930.
- Scarisbrick, Diana. *Rings: Symbols of Wealth, Power, and Affection*. London and New York: Abrams, 1993.

*Anna Beatriz Chadour-Sampson*

**RING-SPUN YARNS.** See **Yarns.**

**ROBE** The word “robe” has an intriguing etymology, its stem coming from the verb “rob,” whose original meaning was the spoils of war. Its primary definition in English specifies it as a garment worn in the European Middle Ages, its most salient features being a long, loose, billowing form and its use as a signifier of rank, office, or special position. “Robe” is often used interchangeably with the word “gown,” though the original meaning of the latter denotes clothing styles particular to classical antiquity, such as the Roman toga. Common usage in the early twenty-first century expands these definitions further, to include a variety of garment forms ranging from informal bathrobes to women's formal evening wear and wedding gowns.

Loose-flowing outer garments in general have come to be known in the modern English-speaking world as markers of certain members of the clerisy, professoriate, or legal profession. Indeed, the words “robe” and “gown” are used as metonyms, shorthand terms that stand for each of these groups as a distinct social class. For exam-

ple, “robe” or “black robe” can refer either to monks, especially missionaries, or to judges, while “gown” is the preferred term for representing scholars and professors, as seen in the phrase “town and gown.” These particular professional garments are all in one way or another based originally on ecclesiastical vestments, though the ones worn by judges and professors have undergone major changes in usage. In the early 2000s, judicial robes and academic gowns are worn over everyday costume and only on formal occasions, and so are therefore made of lightweight fabrics.

### Religious Robes

The plain, ankle-length robe of Christian monastic orders was anything but lightweight. Patterned after the long, wide-sleeved tunic of Roman times, it was necessarily made of coarse and humble material, usually wool. The monastic robe was an all-purpose garment worn by both men and women. There were slight variations of it over time among the different orders, but it kept to a single basic form that was meant to represent the Christian ideals of poverty and humility. Rules stipulated that the fabric should be the cheapest kind available in the local community and that the garment should be gathered and tied at the waist at all times. As for color, these robes tended to be neutral (subdued or understated), in dark or light tones. The overall effect was one of simplicity and timelessness.

Robes—as garments signifying special individuals or distinct social groups—are a worldwide phenomenon. Their visual features cannot be precisely defined. Robes of many shapes, sizes, designs, and cuts have been employed to represent certain religious or ethical principles, to designate members of religious orders, and, in some cases, to delineate levels of rank within them. One well-



**Zen Buddhist robe.** This sixteenth century statue depicts the bodhisatva Kishitigarbha wearing an ornate example of the robes that were traditional to Japanese Zen Buddhism at that time. SEATTLE ART MUSEUM, EUGENE FULLER MEMORIAL COLLECTION. PHOTO CREDIT: PAUL MACAPIN.



### STYLE IN THE COURTROOM

U.S. Supreme Court Chief Justice William Rehnquist made news in January of 1995 by adding a striking feature to the traditionally plain, black robes that have been worn by the justices for two hundred years. He was inspired to make the change after attending a performance of the Gilbert and Sullivan operetta *Iolanthe*. In it, the character of Lord Chancellor, speaker of the House of Lords in Britain, was handsomely costumed in a robe adorned with vividly colored stripes. Rehnquist wanted the same, and had four gold stripes sewn onto each sleeve of his own judicial robe, giving it a rather sporty look. As of 2004 the other justices have stayed with their basic black. (Reske, p. 35)

documented example of the latter is the system of robes that developed among Zen Buddhist monasteries of Japan. Individual monks were restricted to three robes. One of them was worn as an everyday garment, another more formal robe was for special occasions within the monastery, and the best one, the “great robe,” was reserved for ceremonies and duties outside the monastery. The color of the robe varied according to the individual’s rank within the religious hierarchy and also according to where his community was placed in the rankings of particular monasteries. At one end of the spectrum were the ordinary provincial priests who wore black robes, while at the other end were the heads of the imperial monasteries in Kyoto, who were allowed the privilege of wearing yellow ones. Another robe, a *kesa*, was worn on top, draped over one or both shoulders. It was a rectangular patchwork stole made of silk brocade remnants, and followed a system of ranking based on the number of pieces sewn together.

An extraordinary mantle from an archaeological site in Paracas, Peru, offers us glimpses of religious robes that



**Sokoto Caliphate robe.** The Sokoto Caliphate encouraged the manufacture of robes, such as the late nineteenth or early twentieth century example displayed here, and bestowed them to notable citizens as a mark of honor or achievement. © NATIONAL MUSEUMS LIVERPOOL. REPRODUCED BY PERMISSION.

were in use there before the Incan Empire. Excavated from the tomb of an important and revered figure, most likely a priest, the rectangular cloth is made of cotton that is then painstakingly embellished with polychrome wool embroidery. What remains of its border consists of a frieze of ninety figures that are depicted in remarkable detail. Altogether they portray a vibrant pantheistic ideal that permeated these peoples' belief system. Human beings merge into animals and plant forms, suggesting that all of life was conceptualized as intimately and spiritually interconnected. The more elaborately dressed and equipped figures in the frieze wear mantles of varying length draped over the body, some of them with zoomorphic terminations. Interpreting the identities of these figures is problematic. Nevertheless, on the basis of their headdresses and the types of implements held in their hands, it appears very likely that the ceremonial robe or mantle was a prerogative shared by priests and war leaders.

#### **Court Robes**

Robes also became institutionalized in various parts of the world at different times as a major component in in-

vestiture ceremonies for political leaders. Such was the case in Christian Europe, where the coronation of kings and queens relied heavily on symbolic regalia, especially crowns, robes, and scepters. Coronation robes were often based on the vestments of bishops—tunic, chlamys, dalmatic—which were thought of and revered as ancient garb dating back to the kings and priests of Old Testament times. As such, these garments were deemed appropriate vehicles for articulating the transformation of a royal candidate into the holder of sacred office. Similarly, the robing ceremony itself paralleled the ritual of Christian baptism. One prominent example is the 1953 coronation of Elizabeth II of England. Held in Westminster Abbey, according to tradition, the ceremony began with the singing of a psalm dating back to the coronation of Charles I. Then came the entrance of the Queen, wearing her white coronation robe, an elegantly embroidered formal gown. Draped on her shoulders was a very long crimson cape, its train carried by six attendants. She was escorted by two bishops, resplendent in their brocaded ceremonial copes. The service consisted of four main segments: the recognition, when the queen



was presented to her people; her swearing of the oath of office on the Bible; the anointing ritual, with the queen wearing a plain white robe; and, finally, the robing ceremony, during which the Mistress of the Robes helped her don the spectacular royal tunic and belt. A much more elaborate cape was draped on her shoulders for the final act, the crowning of the queen. Throughout, the term “robe” referred to the queen’s garments—gown, cape, tunic—and the ceremonial changing of them to symbolize her ascension to the throne.

One of the most well-known examples of imperial robes is the Chinese “dragon robe” tradition. Although the emperor himself and his throne were symbolized by dragon imagery, this was not a garment reserved for him alone. The dragon robe proper meant a particular type of garment worn at court and by government officials, especially during the Qing Dynasty (1644–1911). Over time, the garment style varied from ample, flowing forms to trimmer, more tailored ones. In all cases, the dragon motif was central, either brocaded into the textile or embroidered onto it with silk and gold threads. Early versions of the dragon robe included design features deemed appropriate for certain ranks, such as the placement of dragon motifs, their scale, and how the dragon was depicted. After 1759, a set of laws were put in place in an attempt to systematize the imagery and regulate who was entitled to wear it. For example, only the emperor’s robe could be brilliant yellow, with nine golden dragon motifs, while the robe of the heir apparent was a shade of orange-yellow. Background color and the number of claws on the dragon were features that distinguished rank among the imperial princes. Although these rules were not strictly followed, the visual elements remained relatively constant until the ending of the dynasty and its costume traditions in 1911. Dragon robes, along with kimonos and other similar garments, have served as inspiration for modern designers of elegant dressing gowns and housecoats for men and women.

### Robes of Honor

Yet another kind of robe became an institution—the “robe of honor”—which was developed most fully in the Muslim world for designating and formalizing a variety of important relationships. It circulated in special ways, being ceremoniously awarded from one individual to another in order to confer authority, seal alliances, and publicly proclaim official ties and positions. Already in ancient times, rulers in parts of Asia had personally bestowed valuable garments on their followers as a sign of special favor. The prophet Muhammad reportedly did this as well, which set the precedent for the robe of honor—*kbi’la*, in Islam. Muhammad’s successors, caliphs of the Umayyad and Abbasid dynasties, wore robes of office that were identifiable by their embroidered borders. The *kbi’la* was patterned after these official garments. During the Abbasid period, production and distribution of honorific robes expanded—especially under

the rule of Harun al-Rashid (786–809), when thousands of them flowed into and out of his treasury. A distinctive feature of the robe of honor was the type of imagery embroidered along its border, which included signs, symbols, or epigraphic inscriptions referring to the reigns of specific rulers. Such robes were ceremonially bestowed by many people in a variety of contexts—patron to client, scholar to student, merchant to merchant—thereby encouraging a sense of loyalty among individuals who otherwise might differ according to their ethnicity, religion, language, social class, profession, or family group. Circulating robes of honor became, therefore, an effective social and political tool for creating solidarity within the cosmopolitan cultures of Islam.

The example of the Sokoto caliphate (1804–1903, became northern Nigeria) shows that robes of honor were influential in other ways as well. Over the century of its existence, this Muslim state grew to be the largest polity in West Africa, and it impressed Europeans with the quality and volume of its cotton textile production. At least some of this achievement can be credited to the robe of honor tradition and how it was subsidized and encouraged by the caliphate’s leaders and elites. Intent on bringing about an Islamic revival, they promoted, among other things, the manufacture and circulation of flowing robes with a distinctive pattern of motifs embroidered in silk along the neck and pocket. They were instantly recognizable as caliphate robes, and the imagery signified divine protection and good fortune. Favorable taxation policies encouraged merchants to set up spinning and weaving workshops, while officially supported Quranic scholars managed the work of hand embroidery. As in the Abbasid period of classical Islam, robes were brought into the central and emirate treasuries in large quantities as tribute and spoils of war. They were then redistributed, as a mark of military achievement or appointment to office, and as a gift to honorable allies, subordinates, and foreign visitors. In 2004, similar robes were made in Nigeria for sale in the market, though most of these were embroidered by sewing machine.

Many robes and robing traditions are no longer being made or practiced; fortunately, some have found their way into museum collections. As objects of study and exhibition display, they remain richly rewarding in their new role as documents of cultural and social history.

*See also* **Religion and Dress; Royal and Aristocratic Dress.**

### BIBLIOGRAPHY

- Brinker, Helmut, and Hiroshi Kanazawa. *Zen: Masters of Meditation in Images and Writings*. Zurich: Artibus Asiae Publishers, 1996. Masterful catalogue of the art and culture of Zen.
- Cammann, Schuyler. *China’s Dragon Robes*. New York: Ronald Press Company, 1952. Classic study of the history and variants of the dragon robe.
- Country Life: Coronation Number*. London, June 1953. Facsimile edition, June 2003.

- D'Harcourt, Raoul. *Textiles of Ancient Peru and Their Techniques*. Seattle: University of Washington Press, 1974. Invaluable description and technical analysis of major Peruvian archaeological textiles.
- Gordon, Stewart, ed. *Robes and Honor: The Medieval World of Investiture*. New York: Palgrave, 2001. Excellent edited volume containing cross-cultural case studies of robes and robing ceremonies.
- Kruger, Colleen. "Robes of the Sokoto Caliphate." *African Arts* 21, no. 3 (May 1988): 52–57, 78–79, 85–86. Case study of the robe of honor in a nineteenth-century West African caliphate.
- Pollack, David. *Zen Poems of the Five Mountains*. New York: American Academy of Religion, 1985.
- Reske, Henry J. "Showing His Stripes." *ABA Journal* 81, no. 3 (March 1995): 35.
- Stillman, Yedida Kalfon. *Arab Dress: From the Dawn of Islam to Modern Times. A Short History*. Leiden, The Netherlands: Brill, 2000. Excellent synthesis of research on Arab and Islamic dress.

Colleen E. Kruger

**ROMA AND GYPSY** Roma is the Romani word used to refer to Gypsies, a label that has pejorative connotations. Since many Roma use the term Gypsy with outsiders, and there are contexts in which Gypsy is the broader term, its use is still applicable in certain settings and certainly appears in literature as well as search engines. In Europe and the British Isles, terms such as Romanies, Travelers, or Tinkers are also used. Many different groups form the Roma population based on a common sense of belonging, although they may have very diverse characteristics and call themselves by different names.

Roma live in the United States, South America, Europe, Russia, Middle East, North Africa, and North and Central Asia. Some have migrated to Australia, Hawaii, and Alaska as well. The Roma migrated into Eastern and Western Europe in the fourteenth century through Persia en route from India, which they left approximately 1,000 years ago. Since leaving India, Roma have always lived within another culture or country as a minority and pariah group. They have been subjected to extreme discrimination and persecution throughout history, especially in Western and Central Europe where they were enslaved in the Middle Ages. Between 500,000 and 600,000 European Roma perished under the Nazis in World War II. In the nineteenth century they migrated to North and South America where they continue to be a nomadic or semi-nomadic group.

Roma in the United States are estimated to range between 100,000 and 300,000 members of various groups (such as Vlach Roma, Boyash, Irish Travelers, and Hungarian Roma) living in all parts of the country. Estimates of Roma in Europe are between 4 and 10 million, with the largest numbers concentrated in Central European and Balkan countries (as much as 5 percent of the pop-

ulation). Different groups have taken up various occupations, including music, metal work, buying and selling horses or cars, fortune-telling (primarily women), and selling craft items. Middle-class Roma have entered the professions, but in the early 2000s this was still a relatively small group.

Roma trace descent through both parents but take on patriline names and have a patrilocal marriage preference. Authority is based on age, with both older women and men enjoying a high status. Men are powerfully situated in the system of juridical authority, and women hold power through the complex system of religious, spiritual, and medical authority. Roma have no religious specialists other than older women, but they use clergy from local churches to conduct baptisms. In the United States their own religion is punctuated by certain rituals, including the baptism of a six-week-old child, marriage, the *pomana* (death ritual), *slava* (Saint's Day feast) and some American holidays, such as Easter and Thanksgiving.

In the United States, Roma generally live in urban areas, usually on main streets and in the poorer parts of towns. They are not as easily recognizable to the American population as they are in Europe, where they stand out more. They often prefer to represent themselves as a member of an ethnic group other than Roma since it abates the stereotyping and discrimination against them. One of their survival mechanisms is to keep to themselves and avoid contact with non-Roma except in work-related circumstances.

The Roma wear clothing that reflects their religion, customs, and ethics. Many Roma, both men and women (but not children), treat clothes worn on the upper body separately from clothes worn on the lower body. Upper and lower body clothes may be washed separately as the lower body is considered "impure," and it is desirable not to "pollute" the upper body. The head in particular is protected from impurity. Hats worn by men and scarves worn by married women are kept away from any surface (such as the seat of a chair) or other clothes that touch the lower body. In addition, men's clothes may be kept separate from women's clothes, and women's skirts are considered dangerously polluting to a man. Women must wear a skirt long enough to cover their legs at least to the mid-calf. Items (such as dish towels) that are used with food are also given particular attention to purity.

During ritual occasions, the Roma often purchase or make new clothes to wear. New clothes have never touched anyone's body and therefore are guaranteed to be pure. A Saint's Day feast, wedding, or *pomana* (death ritual) are occasions when special pure clothing is desirable. During the *pomana*, a living person representing the deceased is dressed in new clothes and is called "the wearer of the clothes." This person stands in for the spirit of the deceased who is thought to be watching the *pomana* to make sure the relatives are displaying the proper respect for the dead.



**Roma men.** A group of four young Roma men in Brasov, Romania. In Roma tradition, hats are kept away from any surface and must not touch any clothing on the lower body. © WOLFGANG KAEHLER/CORBIS. REPRODUCED BY PERMISSION.

The presentation of self through dress and fashion is very important to the Roma and part of their public performance as Roma. Roma fashions do change over time and place. Furthermore, fashions for men and women seem to be based on different criteria. Whereas men dress to present an image to the outside world that they associate with power and authority, women dress to present an image to the Roma that is associated with Roma ideas of the power of purity and pollution.

### Men

In the United States Roma have adopted fashions that project a particular masculine stereotype, often gleaned from the movies. Their public and private appearance is a performance of a certain recognizable style that they associate with masculinity and authority. They are not concerned with being stylishly up-to-date, rather they are concerned with the images of power projected by the clothing. Examples of commonly seen styles include:

1. Urban cowboy—hat, cowboy shirt, bolo tie, jeans, and boots; sometimes a Western-style jacket.

2. 1930s Chicago gangster—loose pants, two toned shoes, wide splashy tie, and double breasted jacket.
3. Palm Springs golfer—white or loud color pants, red golf shirt, Irish hat.
4. Casual modern—polo shirts, white shirts, or Hawaiian shirts, long pants.

Young men who are not yet old enough to present an image of power may adopt a more youthful modern dress. For example: (1) Beatles attire—pencil thin tie, loud tight shirt, and stove pipe pants; (2) Spanish or Hungarian Gypsy musician—longish hair, red diklo at the neck, “Gypsy” shirt; or (3) Modern—shirt and baggy shorts.

### Women

Women are interested in fashion that shows their sense of “shame” and their status as guardians of purity for the family. Because of this role, women are expected to cover their legs at least to the mid-calf. Married women traditionally cover their head with a scarf and tie their long hair up or braid it. There is no shame associated with



## ROYAL AND ARISTOCRATIC DRESS

showing a low-cut neckline; in fact, it is rare to see a woman who does not wear low-cut tops. Women may wear modern western clothing when they do not want to be recognized as Roma. Some, for example, wear “Hopi” Indian dress to “pass” as American Indians. Even within these limitations, women have a great deal of leeway to adopt different styles:

1. Traditional Serbian or Russian Roma—homemade, long, pleated, light chiffon, sari-like skirt; tight low-cut blouse with V-neck showing cleavage; bra that acts as a pocketbook and place for cigarettes; hair put up in a chignon or bun; pocket handkerchief or larger style scarf on the head; flat shoes.
2. 1970s fashion—store-bought suit with A-line maxi-skirt and fitted jacket; floppy straw Easter bonnet hat; high heels.
3. Eastern European Roma contemporary—flowered, bright calf-length skirt; short puffed-sleeved peasant blouse with gold coins around the neck; and scarf on head; barefoot or in flat shoes. (Located in Bulgaria, Romania, Hungary.)
4. Spanish Roma entertainment—flamenco dress that is calf-length; bright polka-dot material; sleeveless low-cut top.

### Children

In general, children are considered pure until puberty and do not have to worry about being polluting or being polluted. Mostly they wear current store-bought American clothes. Very small children can wear shorts or tank tops. Boys wear jeans and a shirt, and on special occasions a suit. Girls wear dresses or pants, and on special occasions long dresses. They usually have long hair hanging down or a ponytail.

See also **Ethnic Dress; Fashion and Identity; Religion and Dress.**

### BIBLIOGRAPHY

- Gay y Blasco, Paloma. *Gypsies in Madrid: Sex, Gender and the Performance of Identity*. Oxford: Berg, 1999.
- Sutherland, Anne. *Gypsies: The Hidden Americans*. Prospect Heights, Ill.: Waveland Press, 1986.
- . “Pollution, Boundaries and Beliefs,” In *Dress and Identity*, pp. 436–444. Edited by Roach-Higgins, Mary Ellen, Joanne Eicher and Kim Johnson. New York: Fairchild Publications, 1995.

Anne Hartley Sutherland

**ROYAL AND ARISTOCRATIC DRESS** Rules governing ceremonial court and aristocratic dress not only reflected power ranking in the premodern world, but also were designed to reaffirm the legal status of royal and aristocratic privilege, and thus to secure the influence of the ruling class. Elisabeth Mikosch (1999, pp. 18–19) points out a dramatic example of how the wearing of royal clothes was taboo to others:

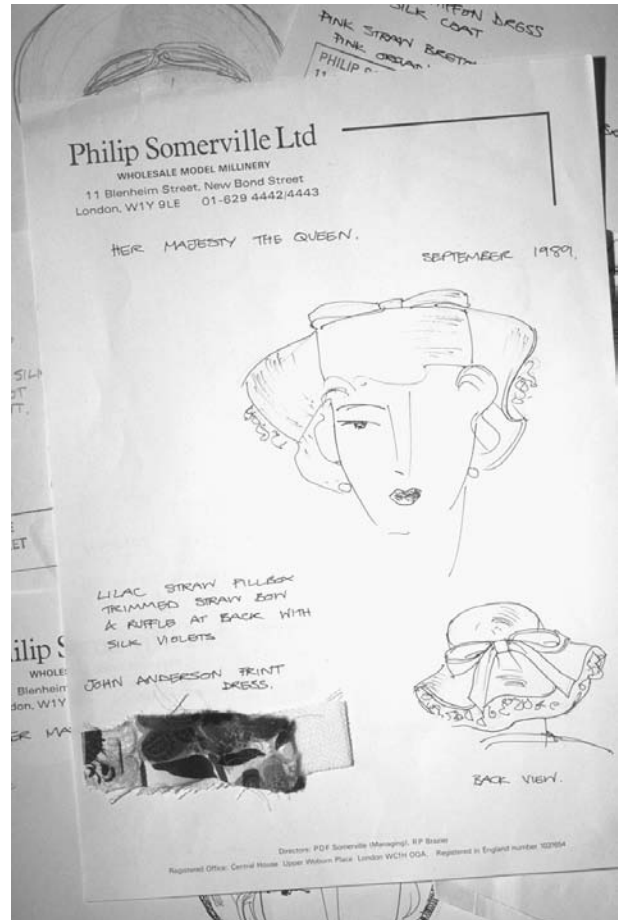

**Philip Somerville design.** Philip Somerville Ltd. Designed fashions for Britain's Queen Elizabeth II. © TIM GRAHAM/CORBIS SYGMA. REPRODUCED BY PERMISSION.

After her flight from Lochleven to Carlisle, Mary [Stuart of Scotland] was in dire need of clothes and asked [Queen] Elizabeth to send her some dresses. Elizabeth harshly denied her request, because Mary had not asked Elizabeth for just any kind of clothes, but for used dresses from Elizabeth's own wardrobe. As a reply, Elizabeth sent some lengths of black velvet, black satin and black taffeta. With this gift Elizabeth not only denied Mary royal dignity but also sent a sharp reprimand for Mary's personal behavior.

Ceremonial dress rules were also used by rulers to express their political opinions. In 1766 Emperor Joseph II decided to abolish the wearing of Spanish-style dress at the Viennese court, as the “Spanish cloak dress” was understood as a symbol for “an absolute ruler, who represented the entire state” (Mikosch 1999, pp. 49–50). Thus, it was inappropriate for the court of an Enlightenment monarch. The “Spanish cloak dress” was a fashionable predecessor of the uniform court dress or *justaucorps*. It was the obligatory court dress for gentlemen at the Vienna imperial court from the seventeenth



**King Charles I and Queen Zita of Austria-Hungary.** The elaborate ceremonial dress worn by royals prior to World War I was an indication of exclusive power and prestige. © UNDERWOOD & UNDERWOOD/CORBIS. REPRODUCED BY PERMISSION.

century until 1766. Court ceremonial required that one had to wear it whenever the emperor was in residence. Mikosch traces its antiquated form back to the fashion of the second half of the sixteenth century and describes it as follows:

The dress consisted of a tightly fitted short doublet with a collar and cuffed sleeves as well as breeches and a circular wide cloak or cape [Spanish *cappa*] reaching to the knees and displaying a flat collar. A rich lace collar or a falling band of lace or fine linen, called a *rabat*, and a large hat decorated with ostrich plumes, completed the ceremonial male dress.

Comparing the state portraits of the emperors Leopold I, Joseph I, Charles VI, and Joseph II, one finds that the main features remained unchanged throughout their reigns, but certain details were altered to conform to changing fashions. For special occasions the clothes were made of silk fabrics richly woven with gold threads (*drap d'or*), lined with silver fabric (*drap d'argent*), and abundantly trimmed with gold lace.

Lady Mary Wortley Montagu notes that in Vienna in 1716 “I saw t’other day the gala for Count Alheim, the emperor’s favourite, and never in my life saw so many fine clothes illfancied. They embroider the richest gold stuffs; and provided they can make their clothes expensive enough, that is all the taste they shew in them” (*Letters of Lady Montagu*, vol. 1. p. 249).

Austrian books of emblems or *impresa* from the beginning of the eighteenth century show ladies’ Spanish court dresses. The cut of these resembled the pattern of the *grand habit* or *robe manteau*, modeled after late seventeenth-century French court dress from Louis XIV’s new palace at Versailles. The ensemble consisted of a skirt with a train and a matching stiff bodice that was drawn into a long point toward the waist; it had short sleeves and a very décolleté neckline that displayed the shoulders and bosom. Rows of lace ruffles and *engageantes* of fine lace decorated the short sleeves. The wide skirt had a long train and it was generally open in the front and turned back to reveal a petticoat. The skirt was sup-



*Roderick Random* (1748), Tobias Smollett's (1721–1771) first novel, shows a boisterous and unprincipled hero who answers life's many misfortunes with a sledgehammer; but sometimes he does very well and then he acquires possessions like the following:

"My wardrobe consisted of five fashionable coats full mounted, two of which were plain, one of cut velvet (velvet having the pile cut so as to form patterns), one trimmed with gold, and another with silver-lace; two frocks, one of white drab (sort of woollen cloth) with large plate buttons, the other of blue, with gold binding; one waistcoat of gold brocade; one of blue satin, embroidered with silver; one of green silk, trimmed with broad figured gold lace; one of black silk, with figures; one of white satin; one of black cloth, and one of scarlet; six pair of cloth breeches; one pair of crimson, and another of black velvet; twelve pair of white silk stockings, as many of black silk, and the same number of fine cotton; one hat, laced with gold *point d'Espagne* [kind of lace], another with silver-lace scalloped, a third with gold binding, and a fourth plain; three dozen of fine ruffled shirts, as many neckcloths; one dozen of cambrick handkerchiefs, and the like number of silk" (Smollett, p. 256).

ported by stays, and its shape, whether slender, round, or wide, depended on contemporary fashions. False or hanging sleeves were reminiscent to the original Spanish roots of the dress and called "*Adlerflügel*" (eagle's wings).

Lady Wortley Montagu observed of the Viennese court: "Their dress agrees with the French or English in no one article but wearing petticoats, and they have many fashions peculiar to themselves; as that it is indecent for a widow ever to wear green or rose colour, but all the other gayest colours at her own discretion" (*Letters of Lady Montagu*, 1866, vol. 1, p. 248; fine examples given by Bönsch 1990, 176/14 and 15). A letter from Johanna Theresia, countess of Harrach, to her husband, Ferdinand, on 9 December 1676, illustrates the importance of fashionable dress at court. The countess wrote that she had bought light-colored underwear for herself and their daughter from a merchant, "for when the Empress arrives, one has to have something to wear, for it is impossible to show up wearing nothing" (Bastl 2001, p. 365).

The impact of fashionable dress worn in elite circles, and the ability of rulers to make political statements through their dress can be seen in Charles Le Brun's tapestry series called *History of the King*. The scene illustrating the meeting between Louis XIV and Philip IV of Spain on 7 June 1660 shows that Le Brun gave precedence to the French king by placing him on the more

distinguished left side of the tapestry and by making him larger than the Spanish king. The fashionable clothes of Louis draw the attention of the spectator, while Philip's clothing looks modest and old-fashioned.

The French court was seen as the new cultural leader of Europe in fashion and court ceremony, and Louis XIV used sartorial rules as a means of exercising power. For example, in 1665 the king awarded to a select group of cavaliers who enjoyed special favors personally granted by the king, the right to wear a blue *justaucorps à brevet* (warrant coat), lined in red and richly embroidered with gold and silver thread according to a prescribed pattern. (Mikosch 1999, 65/57). Paintings of King Louis XIV and his aristocracy provide vivid visual evidence of the importance of fashion at the royal court.

Conspicuous consumption, which expressed social distinction through a lavish lifestyle, was an instrument of royal and aristocratic self-esteem in the eternal con-



**Queen Elizabeth II.** By the early twentieth century, royal dress had ceased to be regulated and ceremonial, and—with some exceptions—the aristocracy were no longer considered fashion leaders. © TIM GRAHAM/CORBIS SYGMA. REPRODUCED BY PERMISSION.



test over rank and prestige. In general, expenditures for clothing correlate less with a person's wealth than with his or her wish to achieve distinction through dress, but in the case of the European aristocracy there was also considerable pressure to dress appropriately to one's status. Maria Magdalena, countess of Hardegg (1595–1657) complained to her father, Georg Friedrich Prüschenk, count of Hardegg (1568–1628, in Vienna), that others made fun of her because of her attire:

I cannot describe to your Lordship how they make fun of me because of my attire; they say it is a shame that I am dressed thus, that my attire ruins a person's looks, and I laugh with them when they criticize my dress, which I would not change for anyone if it were not on your will and order. (Bastl 2001, p. 362)

Aristocratic country life in premodern Europe was relatively simple, even boring; the pace of life was determined by the seasons and by ordinary everyday events, punctuated by celebrations and festive occasions. Festivals appealed to the eye and used a vocabulary of peculiar attributes that are difficult to decipher nowadays, but that constituted a wordless but well understood language at court in early modern times. There was an inevitable tendency for nonmembers of the elite to engage in what is called "power dressing" in the twenty-first century by appropriating elements of elite dress. One sees in this behavior that dress is both intimate and potent as a means of expressing power; much dressing is power dressing, and power dressing is by its very nature political, in that it is public.

In this context the "big event" of a wedding became a celebration that, like everything else, needed to be regulated within the order of a hierarchical society. When Anna of Starhemberg (1513–1551) had to wed her niece Elizabeth to Marquart of Kuenring in 1536, she was in charge of putting together the bride's wardrobe. In one of her letters (15 November 1536) she writes to her husband Erasmus about Elizabeth's wedding dress:

Since you wrote to me that Els [Elizabeth] needed a white beret for her white damask dress, I want to let you know that she is not going to wear a beret but a wreath, which she has to wear at her betrothal. Also, when you said that she is going to need a red beret, I don't think it is necessary because she has a pretty one with a pearl border although it is only black; give it to her, with the jewels on it. But if you want her to have a red one to go with her red velvet jacket, you can get one that has nothing on it so that we can sew the jewels on to it. (Bastl 2001, pp. 363–364)

This letter is revealing for various reasons: For one, it is an early documentation of a white wedding dress, which was already worn with a wreath at the engagement party, although the "beret" (Bönsch 1990, pp. 174–175) was also considered to be appropriate headwear at a wedding. Secondly, it is clear that the color red for garments also achieved similar, perhaps even greater, popularity with the nobility and was worn in matching shades for the dress and



## BLACK AND WHITE

The color or rather the non-color, black was associated with the grave impersonality of authority. In Europe its oldest association is with death, with grief, and with the fear of death. As the color worn by mourners, its use is very old. It is sometimes suggested that the use of black for mourning was a medieval development: but its use at that time was a revival, not an invention. Roman mourners wore black togas (though the deceased body itself was wrapped in a white toga). And funeral processions in ancient Greece wore black. We are dealing in death with a reversal of the dress code, which converts elegant court attire "a bright red-colored precious dress with trim of silver lace of Spain"—to a funeral dress, or as Anna Maria Countess of Trauttmansdorff writes in her last will of 1704, "the black court gown: the clothing of my corpse in a dark taffeta nightgown." This is an ambivalent procedure in more ways than one: on the one hand, the clothing of the live body in garments that are considered to be beautiful and that maintain or promote status; on the other, the clothing of the dead body with garments that are ugly, and hence diminish or reduce status (Bastl 2001, p. 371).

the hat. Apparently velvet was also considered to be a fabric similar in value to damask, since they seem to have been interchangeable for wedding attire. Most generally, it is understood that clothing itself is a matter of intense concern for the family of the bride at an elite wedding.

Clothing was precious and expensive and was worn throughout a lifetime. In 1595 Helena of Schallenberg was a lady-in-waiting at the court of the duke of Bavaria, and she wrote to her brother:

I am asking you with all my heart to ask our father for a martenskin—I cannot go without one. I have not had one made since I was a child. I have had a coat long enough—all my life—for which one cannot buy a lining at the market. I cannot wait any longer. We have to go to the Reichstag in appropriate dress and other necessary things; but I don't know how to go about it. (Bastl 2001, p. 365)

In the above-mentioned letters, Maria Magdalena of Hardegg wrote to her father in September 1616 that her late mother's lambskin has become too small for her and her little sister Sidonia might have her dressing gown, which she was not able to wear any more. The implication is that were she still able to fit into these clothes she would expect (and be expected) to continue wearing them, rather than replacing them with new clothing.

Aristocratic families must have had collections of clothes, for the tailor Hans Janoss found “an old tanned wool fabric dress, completely redone, sewn with fringes on it” in Regina Sybilla Countess Khevenhüller’s trousseau in 1627. The same was true in sixteenth-century England, where Anne Basset had been criticized by Queen Jane Seymour and her ladies for her smocks and sleeves because they were “too coarse” and asked Lady Lisle to send finer material for new ones. Instead, “the Countess of Sussex had decided to have Anne’s old gowns made into kirtles (skirts, or skirts and bodices) to save some expense” (Harris 2002, p. 229).

The discourse about court culture and aristocratic behavior and clothing in late nineteenth- and early twentieth-century Germany came to a curious conclusion. French *civilisation*, which implicated the art and artifice of fashion (expressed, for example, in the imperial court of Napoleon III), was dismissed as superficial, opposed philosophically in the emerging ideology of German nationalism by “deep” German *Kultur*, which was hostile to fashion (Duindam 2003, p. 295). At the same time, fashionable clothing was readily available to a much wider segment of the population than ever before; the court and its clothing no longer held a privileged position as the leader of fashion.

By the end of World War I, aristocratic titles survived in some European countries and were abolished in others, but royal and aristocratic dress lost its distinctiveness and exclusivity throughout European society. In the twentieth century, some royals were fashion leaders (Edward, Prince of Wales; Princess Grace of Monaco) and others were models of bourgeois respectability (Queen Beatrix of the Netherlands, Elizabeth II of England), but royals and aristocrats as a group no longer dressed in distinctive and regulated clothing, and were no longer society’s principal leaders of fashion.

See also **Court Dress; Uniforms, Diplomatic.**

#### BIBLIOGRAPHY

- Arnold, Janet. *English Women’s Dresses and Their Construction c. 1660–1860*. London: Macmillan, 1964.
- . *Patterns of Fashion: The Cut and Construction of Clothes for Men and Women c.1560–1620*. London: Drama Publishers, 1985.
- Bastl, Beatrix. “Das Österreichische Frauenzimmer. Zur Rolle der Frau im höfischen Fest- und Hofleben 15.–17. Jahrhundert.” In *Slavnost ia zábavy na dvorech a v residenčních mestech raného novověku*. Edited by Václav Buzek and Pavel Král, 79–105. České Budějovice, Czech Republic: 1996. Gives an overview about expenses for clothes for the lady-in-waiting Anna Josepha von Thürheim 1709–1711.
- . *Tugend, Liebe, Ehre. Die adelige Frau in der Frühen Neuzeit*. Wien, Köln, and Weimar, Germany: Böhlau, 2000.
- . “Das Österreichische Frauenzimmer. Zum Beruf der Hofdame in der Frühen Neuzeit.” In *Residenzenforschung 11: Das Frauenzimmer*. Edited by Werner Paravicini, 355–375. Wiesbaden Germany: 2000. Edition of the *trousseau* for the court of Anna Maria Thurn 1559.

- . “Clothing the Living and the Dead: Memory, Social Identity and Aristocratic Habit in the Early Modern Habsburg Empire.” *Fashion Theory* 5, no. 4 (2001): 1–32.
- Bourdieu, Pierre. *Distinction. A Social Critique of the Judgement of Taste*. London: Routledge, 1999.
- Duindam, Jeroen. *Vienna and Versailles. The Courts of Europe’s Dynastic Rivals, 1550–1780*. Cambridge, U.K.: Cambridge University Press, 2003.
- Elias, Norbert. *The Civilizing Process*. Oxford and Malden, U.K.: Blackwell, 2000.
- Harris, Barbara J. *English Aristocratic Women 1450–1550: Marriage and Family, Property and Careers*. Oxford: Oxford University Press, 2002.
- Hollander, Anne. *Seeing Through Clothes*. Berkeley, Los Angeles, and London: University of California Press, 1993.
- The Letters and Works of Lady Mary Wortley Montagu, edited by her great grandson Lord Wharnclyffe in two volumes*. London, 1866.
- Mikosch, Elisabeth. “Court Dress and Ceremony in the Age of the Baroque. The Royal/Imperial Wedding of 1719 in Dresden: A Case Study.” Ph.D. diss., Institute of Fine Arts, New York University, 1999.
- Pallmert, Sigrid. “Kleider machen Leute—Könige machen Mode. Ein Aspekt des sogenannten Allianzteppichs.” *Zeitschrift für Schweizer Archäologie und Kunstgeschichte* 47 (1990): 49–54.
- Roche, Daniel. *The Culture of Clothing. Dress and Fashion in the Ancient Regime*. Cambridge, U.K.: Cambridge University Press, 1994.
- Smollett, Tobias. *The Adventures of Roderick Random*. Oxford: Oxford University Press, 1979.
- Zander-Seidel, Jutta. *Textiler Hausrat. Kleidung und Haustextilien in Nürnberg von 1500–1650*. München: Deutscher Kunstverlag, 1990.

Beatrix Bastl

**RUBBER AS FASHION FABRIC** Natural rubber (*caoutchouc*) comes from latex, the milky secretions of tropical plants that coagulate on exposure to air. Prior to European discovery, the indigenous peoples of South and Central America used rubber to waterproof fabrics. The initial use of rubber in eighteenth century Europe was limited to elastic bands and erasers. Over time, various methods evolved to grind rubber so that fillers and other powders could be incorporated to stabilize thermal and chemical properties. In the United States, Charles Goodyear hit upon vulcanization (the process of treating rubber to give it useful properties, such as elasticity and strength) in 1839. In 1842 English inventor Thomas Hancock used his patented “masticator” on Goodyear’s vulcanized rubber, and what had been a lab curiosity became an industrial commodity.

Successful vulcanization prompted Henry Wickham to smuggle rubber seeds out of Brazil in 1876. British botanical experiments resulted in hardier rubber plants that were exported to Malaysia, Ceylon, and Singapore

where dense plantings increased rubber yield exponentially. During World War I, the Germans invented a synthetic rubber that was prohibitively expensive. When Allied forces were isolated from Asian rubber manufacturing centers during World War II, development of affordable synthetic rubber and rubber-recycling processes became part of the war effort. The reclaiming of cured rubber products was not commercially viable until 1991 when the Goodyear Company developed environmentally friendly devulcanization.

In 1823 Scotsman Charles Macintosh sandwiched rubber softened with naphtha between two thicknesses of woven wool. Macintosh remedied the problem of thermal instability in 1830 by adopting Thomas Hancock's vulcanization process. Draping and sewing rubberized wool proved to be a daunting task, so early floor-length coats were minimally designed. Over time the "mackintosh" came to feature trench coat details that made it more utilitarian and fashionable.

Rubber's elasticity, impermeability, stickiness, and electrical resistance make it extremely useful as an adhesive, protective coating, molding compound, and electrical insulator. Latex is cast, used as sheeting, combined with powder that produces gases to form foam rubber, or oxygenated to form sponge rubber.

By the twenty-first century high-tech fibers and laminates all but replaced rubber for waterproofing apparel. However, from early Sears and Roebuck "sweat" suits to twenty-first century haute couture, the surface qualities of rubber continue to appeal to fashion designers and fetishists alike. In the 1960s, John Sutcliffe's catsuits designed for the Emma Peel character on the TV series *The Avengers* caused rubber to come into vogue. In 2003, rubber wear combined with other fashion fabrics was prominently featured in collections by Julien Macdonald, Helmut Lang, Nicolas Ghesquiere for Balenciaga, and John Galliano for Christian Dior.

Garments constructed of rubberized cloth, rubber sheeting, or molded latex present specific design challenges. Rubberized cloth resists piercing and cannot be pressed; therefore facings and hems must be understitched, glued, or heat welded. Pinholes and tailor tacks will create permanent holes. Because it is difficult to create buttonholes, garments typically feature zipper, Velcro, and snap closures. Grommets are used to vent unbreathable membranes. Garments made of rubber sheeting are more likely to be constructed utilizing cement and heat or pressure welding. Seamless molded garments offer the most serviceable construction.

See also **Fetish Fashion; Rainwear.**

#### BIBLIOGRAPHY

- Allen, Peter William. *Natural Rubber and the Synthetics*. London: C. Lockwood; New York: Wiley, 1972.
- Morton, Maurice, ed. *Rubber Technology*. 3rd edition. New York: Van Nostrand Reinhold Co., 1987.

Norwich, William. "Rubber Maids." In *Fashions of the Times: 60th Anniversary Issue, The New York Times Magazine* (17 August 2003): pp. 76–78.

Michele Wesen Bryant

**RUBBER FIBER.** See **Elastomers.**

**RUSSIA: HISTORY OF DRESS** The systematic study of the history of dress in Russia began in 1832 with the publication of a book by the president of the Academy of Arts, Aleksei Nikolaevich Olenin (1763–1843). The occasion for the writing of this book was a decree of the Emperor Nicholas I, who expressed the desire to see a painting with many figures on the theme of the most important event in Russian history: the baptism of the Russian people by Prince Vladimir. The goal here would be to represent all the classes of Russian society in conditions and clothing that approximated as accurately as possible the actual conditions and clothing.

Actual specimens of Russian dress from early Russian history and even from the ninth to the thirteenth centuries had not been preserved. The only way to recreate what Russians looked like in that epoch was to examine all the possible sources: the archaeological data, all manner of written documents, as well as works of handicraft and decorative art. The most reliable information that we have concerning Russians dress of the pre-Christian period comes from our knowledge of the materials common to that period: hides and leather, bast, wool, flax, and hemp. The style of dress did not differ from that of the other Slavonic nations. This was determined by constant communication between these nations, by a similar manner of life, and by the climatic conditions. Women wore *rubakhi* (long shirts) down to their ankles and with long sleeves gathered up on the wrists; married women also wore the so-called *ponevu* (a kind of skirt consisting of a checked-pattern woolen fabric. Married women completely covered their hair by a *povoi* or *ubrus* in the form of a towel, while maidens wore a *venchik* (a narrow band of fabric or metal) on their foreheads. Maidens of the richer urban families had the resources to ornament themselves with a *koruna*, which differed from the *venchik* only by its more complex shape and finish. Men wore narrow *porty* (trousers) and tunic-like *sorochki* (shirts) of linen, down to their knees or their mid-calves. The footwear consisted in primitive shoes called *lapti* woven of bast, while the city-dwellers wore *lapti* made of raw leather. We also know that men of the upper classes wore boots of fine workmanship. According to the testimony of Akhmet (the ambassador of the Bagdal caliph Muktedir), at the beginning of the tenth century Slavonic men wore cloaks of dense fabrics that left one arm free.

The appearance on the territory of Eastern Europe of the first feudal Slavonic state, that of Kievan Russia,





**Traditional Russian dress.** A group of Russian women, dressed in an elaborate, old-fashioned, Russian style, wait to greet Boris Yeltsin during the 1996 Russian presidential election campaign. © PETER TURNLEY/CORBIS. REPRODUCED BY PERMISSION.

led not only to political and economic advancement, but also to increased trade and diplomatic contacts. At this stage of development, up to the Tatar-Mongol invasion in the thirteenth century, the dress of the upper classes of Russian society corresponded to general European tendencies in the domain of clothing, although it preserved certain native characteristics.

According to tradition, it was the magnificence and great solemnity of the Byzantine liturgy that led the Kievan prince Vladimir to baptize Russia in 988. Grandiosity and pomp, a magnificent manner of walking, became the accepted ideal of beauty in Russia up until the period of the reforms of Peter the Great at the beginning of the eighteenth century. The short-flap male dress virtually disappeared from the Russian court under the Byzantine influence, although peasants continued to wear it for two more centuries. However, the size and length of the dress were substantially reduced compared with what was worn in Constantinople. There was a prohibition against taking many types of fabrics out of Constantinople, and for this reason the garments of the Russian princes and of those close to them were, for the most part, rougher and less colorful. They were made decorative by an abundance of finishing touches on the

collar, cuff, and hem. We know that when Prince Sviatoslav Igorevich (who died in 972) met the Byzantine Emperor John I Tzimisces, he was dressed with emphatic simplicity in a white shirt and *porty*. The sole luxurious object that he wore was a single golden earring with two pearls and a ruby. It was only by the middle of the eleventh century that dress of the Byzantine type took firm root in Russia. A ceremonial garment to be worn in the court was defined by which members of other classes were prohibited from wearing it. It consisted of a *korzno*, a small rectangular or round cloak, which was thrown onto the left shoulder and clasped on the right shoulder by a precious fibula. All that remained of the former dress was a round, fur-trimmed hat and various small details of cut and decoration. There was no difference between the woman's hat and that of the man, although the former was worn with a shawl or veil. Of very ancient origin were the *poliki* and *lastovitsy*—colored inserts on the shoulders and under the arms, which were both extremely functional and also served as a decoration on the linen shirts that peasants wore until the end of the nineteenth century. Members of the upper classes and rich city-dwellers wore such shirts at home. To garments simple in cut a decorative character was imparted by hanging or-

naments: numerous bracelets, beads, finger rings, and small and large *kolty* (earrings) for women. The dress of this period did not reveal the shape of the body but had a bulky character. As a rule, the clothes were put on over the head and had a small decorative opening in front. Russian dress did not have any draping elements, either in the case of the upper classes or, especially, in the case of the peasantry. Common folk contented themselves with *rubakhi* of homemade cloth, while members of the upper classes wore a *sorochka* (second shirt) made of expensive imported fabrics.

One of the earliest images of the princely family is known from the “Collection of Sviatoslav” (1073), which gives an idea of the style of that epoch and which is clearly connected with the tendencies common in medieval Europe. The prince and his son are represented in fur-trimmed hats, which promoted the legend of the “hat of Monomakh.” The Kievan prince Vladimir (1053–1125) received the name “Monomakh” because he was a grandson of the Byzantine emperor Constantine Monomakh, who supposedly sent the regalia and the hat-crown to the son of his daughter. However, it has been established with certainty that the first crown appeared in Moscow only at the beginning of the fourteenth century and was a sharp-pointed golden hat of eastern craftsmanship, with a cross and sable trim. The subsequent hat-crowns were made in the workshops of the Moscow Kremlin in imitation of this headdress (for example, the crown of Peter the Great, 1627).

The Tatar-Mongol invasion led to a break in the contacts with Western Europe, and the immediate proximity with Turkic-speaking peoples led to a change in the form of Russian dress. *Rashpatnyi* clothing with a slit in front from top to bottom appeared, and men wore broad trousers. One must say at once that, even after having borrowed the cut, terminology, and certain elements of this foreign dress, Russians never lost their own national identity when it came to clothing. A good example of this is the caftan, a type of wide-opening garment with a deep wrap-over, worn by both men and women. The old Russian word for this garment is derived from the Persian word. In those cases when, in its fabric and details of cut, the caftan did not differ from the garments of other Eastern nations, it was wrapped over on the right side and belted or buttoned with *klapyshi* (coral, silver, or bone stick-buttons, which, in the twentieth century, Russian artists began to use once again, this time for athletic dress), decorative braided fabric buttons (*uzelki*), or circular buttons. The Russian caftan, in contrast to all the foreign types of cut (Arkhaluk, Turkish), was sewn along the waist with straight gathers, and it could be wrapped over on either side. This feature could be observed in pictures of peasants and common folk up until the middle of the nineteenth century. N. S. Leskov, a celebrated Russian writer, characterized such a caftan as having “Christian folds on the leg.”

The need to protect their national sovereignty compelled Russians to preserve their national dress by modifying imported types of dress. For example, caftans brought from the East or acquired from neighboring nations were decorated according to the local manner: they were adorned with lace, or a collar sewn with *ozherel'e* (stones) was attached to them.

Starting with the fourteenth century, trade between Muscovite Russia and Europe expanded. Brocade, velvet, and various kinds of silk and wool were brought to Moscow from England, Italy, and France. Russia served as the intermediary in the trade between Europe and Persia as well as Turkey. Clothing made of diverse patterned and bright-colored fabrics acquired an especially decorative character, and details consisting of gold (metallic) lace and precious stones made the garments particularly magnificent. It is well known that, during the reign of Tsar Ivan IV (Ivan the Terrible, 1530–1584), foreigners desiring to receive an audience in the Kremlin were required to put on Russian clothing as a way to recognize the magnificence of the Russian throne. In order to make a favorable impression, servants were temporarily given fine and expensive clothing from the tsar’s storehouse.

It was only during the time of Patriarch Nikon (1605–1681) that foreigners were forbidden to wear Russian clothing, since the patriarch was made unhappy by the fact that, when they were in the presence of the head of the Russian church, foreign guests did not fall to their knees but, by remaining standing in Russian dress, disrupted the usual order of things and could exert a bad influence on the people. At the same time, Tsar Aleksei Mikhailovich (1629–1676) made more severe the punishment for Russians who wore European dress or imitated foreign hairstyles.

The boyars wore the richest and most decorative clothing. A distinctive feature of the boyar dress was the *gorlatnyi* or “neck” hat (a tall cylinder made of the neck furs of black foxes or other expensive fur). Boyars gave as gifts and rewards their sable furs, covered with gold brocade or patterned velvet, but they never parted with their hats, which were symbols of their power. At home, their hats were safeguarded on wooden stands with painted designs. The tsar’s everyday dress did not differ from that of the nobles, and during his reception of ambassadors, he was obliged to wear the *platno* (a long, collarless brocade garment that had broad sleeves extending to the wrists). Instead of a collar, *barmy* garments covering the shoulders and decorated with precious stones and pearls, were worn. Only the tsar and priests had the right to wear a “breast” cross. During especially important ceremonies, the tsar had to wear a crown (the hat of Monomakh) and the *okladen'* (a gold chain of two-headed eagles).

The outer formal piece of clothing worn by a nobleman was the *feriaz'* (broad and with long sleeves) and the *okbaben'* (with narrow folded-back sleeves that could

be tied at the back and with a large rectangular folded-back collar). Women and young girls of the nobility wore the *letnik* (a garment with very broad, short sleeves with detachable flaps made of expensive fabrics embroidered with stones and pearls). Because of the heavy fabrics and the abundance of precious stones and pearls, the dress of both men and women was very heavy, weighing as much as 44 pounds.

In the middle of the fourteenth century occurs the first mention of the *sarafanets* (male dress consisting of a long, narrow opened-out garment with sleeves), from which later the main part of the *sarafan*—a long, sleeveless garment which became the national costume of the Russian woman—got its name. This gender confusion is associated with the fact that the original Persian word meant “honorable dress” and referred to clothes made of imported fabric. Only in the seventeenth century did this term come to apply exclusively to women’s clothing. The *sarafan* was worn over the *rubakha* (shirt), and became common in the central and northern regions of Russia. The south preferred the *paneva*, which necessarily was combined with the apron. The sarafans of rich city women were made of silk and velvet, whereas those of peasant women were made of painted domestic linen. The cut of the sarafan differed greatly depending on the place where it was made and on the material: it could be straight, or it could be composed of oblique wedges, *kumanchiki*, *kindiaki*, and so on. Over the sarafan was worn the *dushegreia* (a short, wide jacket).

The enormous extent of the territory, the diversity of the raw materials, and the conditions of life did not favor the creation of a single national costume in Russia. There existed many different kinds of clothing and head-dresses, differing not only from region to region, but even from village to village. In the central and northern parts of the country, the chief decoration of the female head-dress was river pearls, while in the south of Russia it was painted goose down, glass beads and buttons, and woolen embroidery. The names of the headresses also differed: *soroka*, *kokoshnik*, *kika*. But one can say with certainty that all the versions of the national costume—from the most ancient combination with the *poneva* to the later combination with the sarafan—tended toward a general esthetic ideal: a massive, not-highly articulated form and a distinct and simple silhouette.

The men’s national costume was more uniform and consisted everywhere of *rubakha*, *porty*, and belt.

The reforms of Peter the Great changed the dress only of the upper strata of society. The clothes worn by the common folk changed very slowly and were gradually displaced from the cities to the villages. From this time forth it became accepted to speak not of the national dress, but of the people’s dress. The clothes worn by the urban poor and handicraftsmen combined traditional and fashionable elements. Even the rich merchant class did not part all at once with the earlier ideas of dignity. Mer-

chants’ wives might have worn the most fashionable low-necked dresses, but on their heads they wore shawls tied in a special way, the *povoiniki*, and they kept wearing them until the middle of the nineteenth century.

Furniture and the configuration of home interiors changed under the influence of European fashion. Skirts worn on frames made it necessary to replace traditional benches with chairs and to acquire fans, gloves, feathers, and lace to decorate one’s hairdo. Together with decrees, which changed the national dress, the tsar instituted measures to establish the national production of fabrics. Female lace-makers were invited from Flanders and taught weaving to nuns from nunnery workshops. If the efforts to establish a national industry came to fruition only at the end of the century, the dress reform was realized in and transformed both capitals (St. Petersburg and Moscow) very rapidly.

Over the course of his reign, Peter the Great (1672–1725; tsar from 1682, emperor from 1721) issued seventeen decrees in his name that laid down the rules governing the wearing of European-type dress, the types of fabrics, and the character of the trim for uniforms and festive attire. This attests that Peter the Great reserved a special role for clothing in the system of reforms he was instituting. Two decrees—*On the wearing of German dress and footwear by all ranks of people and on the use of German saddles in horseback riding* and *On the shaving of beards and whiskers by all ranks of men, except priests and deacons, on the taxing of those who do not obey this decree, and on the handing-out of tokens to those who pay the tax*—were viewed as disastrous for the sense of national identity in the nineteenth century polemic concerning the consequences of the Petrine reforms. However, here it was not taken into account that, in Peter’s time, the word “German” referred not to the nation of Germany but to foreign lands in general; and what was implied was that Saxon, French, and other elements would be combined to create a European style of dress suitable for solving problems that the reformer-tsar set for himself. As far as the dress for the various military services was concerned, the superiority of the short-flap uniform in the European style was obvious and did not raise any questions. The prohibition against wearing the national dress extended only to the narrow circle of people close to the throne, especially the boyars. In order to institute his new policies, Peter needed new people, whom he enlisted for service to the throne without regard to which class they belonged. The national dress remained a precise indicator of class. Moreover, the consciousness that the peasant’s son who wore the *armiak* (plain cloth coat) had of himself was, even if he was invested with the personal trust of the tsar, different from that of the boyars who wore the hereditary *gorlatnyi* hat and the brocade-covered sable fur. In forcibly changing the form in which class was manifested, Peter did not meet with any resistance. For the lower classes, the wearing of European clothing made it possible to change their lives, and they did this without regrets. But the boyars, who



from ancient times prided themselves on the luxuriousness of their furs, their long beards, and the precious stones they wore in their rings—also were concerned more with preserving the proximity of their families to the throne than with their personal dignity.

In all things the new dress contradicted the traditional clothing. If a man's feet were uncovered, that was a sign that he had not yet reached marriage age; however, the new decree commanded the wearing of stockings and shoes. The former large multilayer garments gave people the appearance of great bulk and were handed down from generation to generation, but the new clothing was cut to the person's figure and was sewn from several pieces. The most troubling consequence of the introduction of the new dress was the change produced in the habitual gestures and behavior. People's manner of walking became less stately; and when the chin was shaved, the need to smooth out one's beard disappeared, and there was thus no pretext to speak more slowly or to be expressively silent. This was accompanied by the disappearance of the *kushak* (sash), which had customarily been worn beneath the waist; and there was now no place to stick one's hands. Nevertheless, the boyars offered virtually no resistance. Only single individuals, inspired by true religiosity and fidelity to tradition, offered any resistance.

The formative element of the European female dress that had been brought to Russia in the eighteenth century was the corset, and it contradicted the Russian ideal of beauty; however, more important for the female dress was a type of headdress—the *fontange*. The latter was successful in supplanting, if only in part, the traditional headdress of the married woman, which had to cover the hair fully. In combination with heavy silken fabrics, this considerably facilitated the assimilation of the new forms. A. S. Pushkin later wrote: "The aged grand ladies cleverly tried to combine the new form of dress with the persecuted past: their caps imitated the sable cap of the Empress Natal'a Kirillovna, and their hoop skirts and mantillas were reminiscent to some extent of the *sarafan* and *dushbegreia*." The first to change their dress were the members of the tsar's family; and members of the court followed them. The Petrine period had already seen the appearance of the notions of "fashionable" and "unfashionable" with reference to European-style dress; and this signified that the reforms had borne their fruit.

Nearly until the end of the eighteenth century, European-style dress (as in the past, Byzantine-style dress) signified that one belonged to the powerful classes, whereas the remaining classes of society retained the traditional dress. The process of the assimilation of European fashions was incredibly rapid. The severe and heavy style of the beginning of the century was replaced fairly rapidly by the rococo style, since with the enthronement of Elizaveta Petrovna (1709–1761, empress from 1741), the quotidian culture and life were oriented toward French fashion.

Catherine the Great (1729–1796, empress from 1762), German by birth and having occupied the throne as the result of a conspiracy, considered it necessary to emphasize the national character of her reign by means of dress. She created her own fashion, including elements of traditional dress. She wore round dresses without a train and a wide-opening outer garment with folded-back sleeves; and in contrast to the French style, the coiffures in the Russian court were worn rather low. This was called fashion "in the manner of the Empress," and it was imitated at the court.

Tsar Nicholas I (1796–1855, emperor from 1825), from the first days of his reign, desired to see ladies at the court wearing Russian dress, and in 1834, a female court "uniform" was introduced by the law of 27 February. Contemporaries called this uniform a "Frenchified *sarafan*," since it combined the traditional headdress and folded-back sleeves with a tightly cinched waist and an enormous train. The gold or silver embroidery on the velvet dresses corresponded to the embroidery on the uniforms of the court officials. This dress continued to exist at the Russian court without modification until 1917. Even men of the nobility who were not engaged in military or civil service were required to wear the noble uniform, and interest in traditional male dress was viewed as ideological opposition to the existing order.

From 1829, industrial exhibitions were held in Russia. The first exhibition of Russian textile articles was held in Saint Petersburg and showed the indisputable successes of Russian manufacturers of textiles, accessories, and shawls. The manufacture of the latter is an important stage in the history of Russian textiles. This marked the first competitive production of fashionable European accessories. The first textile factory for shawls belonged to N. A. Merlina. In 1800, Merlina began to produce reticules (which became fashionable because of the absence of pockets in dresses of the traditional style) and *bordiury* (vertical and horizontal borders); and in 1804 she began to produce complete shawls. Then, in the province of Saratov, D. A. Kolokol'tsov opened his factory. The last to start operation, in 1813, was V. A. Eliseeva's *complete shawl factory*, which meant that it used native, not imported, raw materials. Instead of the wool of mountain goats, the owner used the fur of the saigak antelopes of the southern Russian steppe. Prince Iusupov was also engaged in the production of shawls; his factory in Kupavna, near Moscow, produced fashionable shawls for merchant women and city women, which indicates how ingrained the European fashions became in the everyday life of Russians.

By the end of the nineteenth century, Russian culture, having passed through its period of apprenticeship, had accumulated a vast creative potential, manifested in all spheres of art, including the art of clothing. The best artists of that time, M. Vrubel' (1856–1910), Ivan Bilibin (1876–1942), L. Bakst (1866–1924), and others, created

not only costumes for the stage but also everyday clothing for their female relations and female acquaintances.

The *First International Exhibition of Historical and Contemporary Dress and Its Accessories* was held in Saint Petersburg in 1902 and 1903. In January 1903, the exhibition "Contemporary Art" opened, with an entire section being devoted to dress. The majority of the pieces were based on the sketches of V. von Meck (1877–1932). The interest in the applied arts and in dress in particular was exemplified in the most spectacular manner by the success of Russian stagecraft, justly appreciated by the international community, during the "Russian Seasons" program in Paris in 1908 and 1909, organized by Serge Diaghilev (1872–1929). The European spectator encountered an indisputable innovation in the art of stagecraft: a single artist was responsible for creating the decorations and the dress of all the characters, something unprecedented for either the Russian or the European stage prior to the group of Russian artists associated with the celebrated magazine *The World of Art*.

Alexander Benois (1870–1960), A. Golovin (1863–1930), and N. Goncharova (1881–1962) had an enormous influence on the Parisian public, and L. Bakst was invited to work with the Parisian fashion houses. The influence of Russian artists on the European fashions of the first decade of the twentieth century was indisputable. P. Poire reportedly collaborated with Bakst.

Of the professional dressmakers the most celebrated was N. Lamanova, who started her own business in 1885, and in 1901 began her collaboration with the Moscow Art Theater. It was at Lamanova's invitation that Poire, with whom she frequently met in Paris, visited Moscow and Saint Petersburg in 1911. Lamanova continued to work in Moscow, and after 1917 she became one of the founders of Soviet dress: she participated in the publication of the magazine *Atel'e* (1923), devised programs for teaching the dressmaking craft, and continued her collaboration with the Moscow Art Theater and other Moscow theaters. In 1925, at the Paris world exhibition, Lamanova's collection was deemed worthy of the grand prize "for national originality in combination with a contemporary orientation in fashion." However, shortly after receiving this award, she lost the right to vote because she had used hired workers in her workshop.

Shortly after 1917, the group of constructivist artists who were associated with the magazine *Lef*—V. Stepanova (1894–1958), Alexander Rodchenko (1891–1956), L. Popova (1889–1924), as well as A. Exter (1884–1949)—distinguished themselves in the making of contemporary dress. Rejecting the previous forms of dress, the constructivists proclaimed "comfort and purposefulness" as their main principle. Clothes had to be comfortable to work in, easy to put on, and easy to move around in. The main orientation of their work was the so-called *prozodezhda*, production dress. The basic elements of this

clothing were simple geometrical shapes: squares, circles, and triangles. Particular attention was given to athletic dress; bright color combinations were used to distinguish the various competing teams. The fashion of those years was urban fashion, and the places of action were stadiums and squares, which were appropriate only for young and strong people. Private life, as well as the private person, disappeared. Individual taste was inappropriate. All resources were expended on the industrial production of clothing; here, complicated cuts and intricate ornaments hindered the unceasing operation of the machines.

In 1921, V. Stepanova and L. Popova were invited to the first cotton-print factory in Moscow. Both of them stopped working on machine painting and began to work with great enthusiasm on cotton specimens, preferring geometrical patterns and deliberately rejecting traditional vegetation motifs. The ornaments they created did not have analogues in the history of textiles, and with their bright colors they imparted a festive and fresh appearance to simple cotton fabrics.

The rigid ideological control of all spheres of life in the second half of the 1920s led to a situation in which the creative heritage of brilliant artists was not understood, not actualized, and was forgotten for a long period of time. The rulers considered it necessary to rewrite the recent history, expelling from everyday life all mention of the past and, first and foremost, the material incarnation of the revolutionary aesthetic ideal. The administrative system controlled consumption and encouraged the formation of new elites, offering them the possibility of acquiring clothing in special ateliers and stores. Clothes designers were being educated in the arts department of the Textile Institute, but this profession was not considered a creative one, with corresponding privileges. Furthermore, since there was no private enterprise, these designers could find work only at state-owned firms and institutions (design houses, large specialized studios), submitting to the state plan and worrying that they would be accused of being bourgeois degenerates.

All attempts to express one's individuality through dress, to separate oneself from the faceless gray crowd, were thwarted by administrative measures. In 1949, the word *stiliaga* entered the Russian language and was used to stigmatize lovers of colorful clothing. In each city there appeared a "Broadway" (usually the main thoroughfare of the city, named after the street in New York City); and a promenade on this street could result in expulsion from the Textile Institute or arrest for hooliganism.

The first to legalize the profession and to escape from the administrative captivity was Slava Zaitsev (b. 1938), who established the *Theater of Fashions* (1980), which later became his fashion house. By this time Russia had more than a few brilliant designers who were also recognized abroad. Irina Krutikova (b. 1936) became widely known as a designer of fur clothing and received the title "queen of fur." She resurrected many old tradi-

tions and created new methods for coloring and finishing fur. She opened her own studio in 1992.

The *perestroika* or great political change of the late 1980s made it possible to organize one's own business, to travel the globe, and to open boutiques of international brands in Moscow, Saint Petersburg, and other cities of the former Soviet Union. It also offered great opportunities for both creators and consumers of Russian fashion. This changed the appearance of cities and liberated people from having to expend enormous effort to acquire the necessities of life. Designers appeared who specialized in accessories. Irina Deineg (b. 1961) became known as a designer of both common and exclusive styles of hats. Viktoriia Andreianova, Viktor Zubets, Andrei Sharov, Andrei Bartenev, Valentin Iudashkin, and Iulia Ianina exhibit their collections every year, and at the same they are developing designs for private individuals as well as for mass production, filling corporate orders.

See also **Ethnic Dress; Royal and Aristocratic Dress; Traditional Dress.**

#### BIBLIOGRAPHY

- Kirsaova, R. M. "Kostium v russkoi khudozhestvennoi kul'ture 18—pervoi poloviny 20 vv. (Opyt entsiklopedii)" [Dress in Russian Artistic Culture from the Eighteenth Century to the First Half of the Twentieth Century (An Attempt at an Encyclopedic Account)]. Moscow: The Large Russian Encyclopedia, 1995.
- . "Obraz 'krasivogo cheloveka' v russkoi literature 1918–1930-tykh godov" [The Image of the "Beautiful Human Being" in Russian Literature from 1918 to 1930]. In *Znakomyi neznakomets. Sotsialisticheskii realizm kak istoriko-kul'turnaiia problema* [The Familiar Unfamiliar One. Socialist Realism as a Historical-Cultural Problem]. Moscow: Institute of Slavic Studies and Balkanology, 1995.
- . *Russkii kostium i byt XVII–XIX vekov* [Russian Dress and Everyday Life in the Seventeenth, Eighteenth, and Nineteenth Centuries]. Moscow: Slovo, 2002.
- Lebina, N. B. *Povsednevnaia zhizn' sovetskogo goroda. 1920/1930 gody* [The Everyday Life of the Soviet City in the 1920s/1930s]. St. Petersburg: Kikimora, 1999.
- Molotova, L. N. and N. N. Sosnina. *Russkii narodnyi kostium. Iz sobraniia Gosudarstvennogo muzeia etnografii narodov SSSR* [Russian National Dress. From the Collection of the State Museum of the Ethnography of the Peoples of the USSR]. Leningrad: Khudozhnik RSFSR, 1984.
- Olenin, A. N. *Opyt ob odezhde, oruzhii, nravakh, obychaiakh i stepeni prosveshcheniia slavian ot vremeni Traiana i russkikh do nashestviia tatar* [Essay on the Dress, Weapons, Mores, Customs, and Degree of Education of the Slavs from the Time of Trajan and the Russians to the Tatar Invasion]. St. Petersburg: Glazunov's Press, 1832.
- Prokhorov, V. A. *Materialy po istorii russkikh odezhd i obstanovskii zhizni narodnoi, izdavaemye V. Prokhorovym* [Materials on the History of Russian Dress and the Circumstances of the Peoples' Life, Published by V. Prokhorov]. St. Petersburg: V. Prokhorov, Issues 1-7, 1871–1884.
- Sosnina, N. and I. Shangina, ed. *Russkii traditsionnyi kostium. Il-lustrirovannaia entsiklopediia* [Russian Traditional Dress. Il-

lustrated Encyclopedia]. St. Petersburg: Iskusstvo-SPB, 1998.

Strizhenova, T. K. *Iz istorii sovetskogo kostiuma* [From the History of Soviet Dress]. Moscow: Sovetskii khudozhnik, 1972.

Tereshchenko, A. V. *Byt russkogo naroda* [The Everyday Life of the Russian People]. St. Petersburg: The Press of the Ministry of Internal Affairs, 1848. Reprint, Moscow: Russkaia kniga, 1997.

Zabreva, A. E. *Istoriia kostiuma. Bibliograficheskii ukazatel' knig i statei na russkom iazyke 1710–2001* [History of Dress. Bibliographic Index of Books and Articles in Russian, 1710–2001]. St. Petersburg: Professiia, 2002.

Raisa Kirsanova

**RYKIEL, SONIA** Sonia Rykiel was born Sonia Flis in Paris on 25 May 1930. She married Sam Rykiel in 1953, and was initially inspired to design clothes by her own desire for fashionable maternity wear when she was pregnant with her first child. The clothes she designed were then sold in her husband's boutique, Laura, which he



**Sonia Rykiel.** Acclaimed French fashion designer Sonia Rykiel in 2002. Rykiel spearheaded the boutique movement in France during the late 1960s. © STEPHANE CARDINALE/PEOPLE AVENUE/CORBIS. REPRODUCED BY PERMISSION.



started in 1962. With the opening of the designer's first Sonia Rykiel boutique on the Left Bank in 1968, she spearheaded the boutique movement of small shops selling avant-garde clothes in France at a time when women of fashion were rejecting the constricted styles of haute couture and seeking clothes that projected a more youthful and modern image. The early 1960s were a time of massive cultural upheaval when many social institutions underwent major changes, including haute couture. Along with Emmanuelle Khan, Yves Saint Laurent, and Dorothee Bis, Rykiel was responsible for a dramatic shift from status dressing to the youthful informality of the Rive Gauche. With her extraordinary mass of red hair, pale complexion, and trademark black clothes, she typified the look of Left Bank bohemia.

It soon became apparent that Rykiel's strength was in knitwear design, and she helped to transform a medium previously dismissed as old-fashioned into one associated with covetable items for the young. Offering her clothes in such fashionable New York stores as Henri Bendel and Bloomingdale's, Rykiel was nicknamed the "queen of knitwear" in 1964.

Rykiel created her signature silhouette by cutting the garment high in the armholes and close to the body, with narrow sleeves that elongated the torso. Using a distinctive palette of colored stripes against a backdrop of black,

her designs for knitwear often involved such innovative details as lockstitched hems, reversed seams, and carefully placed pockets. All her clothes tended to be light-hearted with an element of wit, whether in the use of contrasting textures and shapes or in the detailing. In the early 1980s Rykiel began to add words to her clothes—for example, "Black Tie" spelled out in studs on a black leather jacket, or "Special Edition Evening Dreams" emblazoned in rhinestones on the belt of a black lace dress.

As the fashionable silhouette became looser during the 1980s, Rykiel emphasized relaxed tailoring and geometric layers. She diversified into household linens in 1975, with children's wear, men's wear, shoes, and fragrance following in 1993. Her flagship store on the boulevard Saint-Germain opened in 1990.

Rykiel has become a French institution. She received the medal of a Chevalier de la Légion d'Honneur in 1985. Her thirtieth-anniversary show was held in March 1998 at the Bibliothèque nationale de France.

*See also* **Boutique; Paris Fashion; Saint Laurent, Yves.**

#### BIBLIOGRAPHY

Rykiel, Sonia, Hélène Cixous, and Madeleine Chapsal. *Rykiel*. Paris: Herscher, 1985.

*Marnie Fogg*



**SACK DRESS (OR SAQUE).** *See* **Chemise Dress.**

**SAFETY PINS** The first clothing fasteners with the principle of a pin (metal) retained by a bow (generally organic) appeared in central Europe during the Middle Bronze Age in the second millennium B.C.E. From these a variant developed in the thirteenth or twelfth century B.C.E. that archaeologists have identified as the direct ancestor of the modern safety pin. It was a single piece of bronze wire coiled at one end as a spring, with a point that engaged a guard of sheet bronze. With many variants it spread rapidly around the Mediterranean, especially in Greek lands. For male and female wearers it is thought to have been a badge of both worldly and spiritual privilege. Around 500 B.C.E., new trends in clothing construction (especially the toga) ended its prestige in the Mediterranean, though it flourished north of the Alps until the third century C.E., when provincials were granted Roman citizenship with its right to the toga. In the Middle Ages, in the West, the luxury fibula resumed its role as an upper-class ornament.

The nineteenth-century safety pin may have been a conscious classical revival, influenced by increasing museum display of and publication of articles on ancient fibulae. The first U.S. patent for a coiled-wire pin of this type granted to Walter Hunt in 1849 is significantly entitled "Dress-Pin," even though other patents had been issued for "safety pins." The inventor claimed durability, beauty, convenience, and injury protection, in that order. Only beginning in the late 1870s did other inventors add the guard that protected the wearer fully. Crucially, they also developed machinery for automating the production of the pins. By 1914, American factories alone were making over 1.33 billion safety pins annually at a cost of \$0.007 each, a stunning example of the industrial order's democratization of an ancient and medieval luxury product. The maverick economist Thorstein Veblen affixed his watch to his clothing with a safety pin to show his indifference to conspicuous consumption—a gesture of reverse snobbery later followed more drastically by the punk movement's use of safety pins as piercing jewelry from the 1970s onward.

The spread of disposable diapers with snap fasteners after World War II reduced the role of safety pins in the household, or rather redefined safety as protection from embarrassment by malfunctioning apparel. On the negative side, the fasteners' reassuring name conceals their real hazards to unsupervised children, who swallow them all too often. Extracting open safety pins requires special instruments first developed over one hundred years ago, and exceptional medical skill.

*See also* **Brooches and Pins; Fasteners; Pins.**

#### BIBLIOGRAPHY

- Alexander, J. A. "The History of the Fibula." In *The Explanation of Culture Change: Models in Prehistory*. Edited by Colin Renfrew. Pittsburgh, Pa.: University of Pittsburgh Press, 1973.
- Kaghan, Theodore. "Humanity's Hall of Fame: They Gave Us the Safety Pin." *Los Angeles Times*, 1 January 1939, H12.

#### Internet Resource

- Hunt, Walter. 1849. Dress Pin. U.S. Patent 6,281. Available from <<http://www.uspto.gov>>.

*Edward Tenner*

**SAINT LAURENT, YVES** A direct heir of the couture tradition of Gabrielle (Coco) Chanel, Cristóbal Balenciaga, and Christian Dior, Yves Saint Laurent explored, discovered, and polished, in the course of a career lasting more than forty years, the infinite resources of his vocabulary. Taming the signs and codes of his age, he created the grammar of the contemporary wardrobe and imposed his language, which became the inescapable reference of the twentieth century. In search of a uniform for elegance, Saint Laurent combined the greatest rigor of production with extreme sophistication of form to create clothing of impeccable cut with harmonious proportions, where the aesthetic of the detail was transformed into an absolute necessity. "Fashion is like a party. Getting dressed is preparing to play a role. I am not a couturier, I am a craftsman, a maker of happiness" (Teboul 2002).

Yves Mathieu Saint Laurent was born on 1 August 1936 in the Algerian city of Oran, the oldest of the three



**Yves Saint Laurent.** Yves Saint Laurent stands next to Laetitia Casta as she models a wedding dress from his spring/summer 2000 high fashion collection. From the beginning of his career in the 1960s until his 2002 retirement, Saint Laurent was one of the world's most influential fashion designers. © REUTERS NEW-MEDIA, INC./ CORBIS. REPRODUCED BY PERMISSION.

children of Lucienne-Andrée and Charles Mathieu Saint Laurent. He said later: "As long as I live I will remember my childhood and adolescence in the marvelous country that Algeria was then. I don't think of myself as a  *pied noir* . I think of myself as a Frenchman born in Algeria" (Teboul 2002). He entered the Collège du Sacré-Cœur in September 1948. Strongly influenced by the play  *L'École à deux têtes*  of Jean Cocteau, he designed his first dresses: stage costumes for paper puppets with which he performed for his sisters. "I had a terrible time in class, and when I got home at night I was completely free. I thought only of my puppets, my marionettes, which I dressed up in imitation of the plays I had seen" (Benaïm, p. 451).

Saint Laurent designed a good deal, imitating Jean Gabriel-Domergue, Christian Bérard, René Gruau, Christian Dior, Cristóbal Balenciaga, and Hubert de Givenchy. In February 1949 he created his first dresses, made for his mother and his two sisters. At the age of sixteen he attended a performance of Molière's  *L'École des femmes* , performed and directed by Louis Jouvet. Bérard had designed both sets and costumes. Seeing this play inspired in Saint Laurent a passion that he never surren-

dered for the theater. In December 1953 he went with his mother to Paris to receive the third prize in the competition of the Secrétariat de la Laine. There he was introduced to Michel de Brunhoff, who was then editor of the French edition of the essential fashion magazine  *Vogue* .

Back in Oran, he began a correspondence with de Brunhoff, sending him fashion and theater sketches. The following year, armed with his baccalaureat (earning second prize for the philosophy essay and a score of 20 out of 20 in drawing), Saint Laurent settled in Paris and attended the École de la Chambre Syndicale de la Haute Couture for three months. He won first prize for dresses in the Secrétariat de la Laine competition. It was at about this time that, struck by the similarity of Saint Laurent's designs to those of the fall-winter collection of Christian Dior, de Brunhoff decided to introduce him to Dior, who promptly hired him as an assistant. During the next two years—years of apprenticeship and intense collaboration—a lasting complicity was established between the two men. "I remember him above all.... The elegance of his feelings matched the elegance of his style" (Yves Saint Laurent, p. 31).

On 24 October 1957 Christian Dior died from a heart attack at the age of fifty-two. On 15 November Saint Laurent was designated his successor. At age twenty-one he became the youngest couturier in the world. He presented his first collection in January 1958 and had his first triumph with the Trapeze line, which propelled him onto the international scene with its enormous success. He was given the Neiman Marcus Award. That same year he met Pierre Bergé, who soon became his companion and business partner.

While designing six collections a year for the house of Dior, Saint Laurent satisfied his passion for the theater, and he designed his first stage costumes ( *Cyrano de Bergerac* , Ballets de Paris de Roland Petit, 1959). Influenced by Chanel, the spring-summer collection had solid success and provoked a craze, but the autumn-winter collection saw the appearance of a more controversial style: turtleneck knits and the first black leather jackets. Singularly prophetic, Saint Laurent had taken his inspiration directly from the street. Drafted into the Algerian armed forces in 1960, he was replaced at Dior by Marc Bohan.

Saint Laurent was soon declared unfit for service and hospitalized for nervous depression, and it was thanks to Bergé that he was able to leave the army. "Victoire" Doutrouleau, one of Dior's star models and a "marvelous muse" for Saint Laurent, recalls: "He left the hospital anxious, dazed, and alone. Yves a soldier? You might as well try changing a swan into a crocodile!" (Benaïm, p. 108). In open conflict with the Dior fashion house, which he sued for breach of contract, Saint Laurent decided to establish his own couture house in 1961, in association with Bergé. The financial support came from an American businessman, J. Mack Robinson: "I was impressed by such great talent in such a young man. I knew nothing about fashion, and I didn't want to get involved. This



was the realm of Yves, the creator, and I immediately saw that he was a genius” (Yves Saint Laurent, p. 16).

The house opened officially on 4 December 1961. Former employees of Christian Dior left Dior to work for Saint Laurent, and more than half the seamstresses came from the Dior workshops. The graphic designer Cassandre created the YSL logo. Saint Laurent designed his first dress—labeled 00001—for Mrs. Arturo Lopez Willshaw, followed by the famous white feather costume for the dancer Zizi Jeanmaire. In 1962, on rue Spontini in Paris, the house presented its first show, described by *Life* as “the best suitmaker since Chanel” (p. 49). Dino Buzzati, special correspondent for the *Corriere della sera*, wrote: “Closing the show, a wedding dress in goffered white piqué brought an ovation from the public. The pale face of the young couturier then appeared for a moment from backstage; only for a moment, because a swarm of admirers surrounded him, embraced him, devoured him.” This collection was memorable for the Norman jacket, the smock, and the pea jacket, which became “foundations” of the Saint Laurent style.

Saint Laurent designed the sets and costumes for *Les chants de maldoror* and *Rapsodie espagnole*, staged by Roland Petit, and the dresses for Claudia Cardinale in Blake Edwards’s film *The Pink Panther* (1964). In April 1963, accompanied by Pierre Bergé, who had become his Pygmalion, he made his first trip to Japan, where he presented shows in Osaka and Tokyo.

The year 1964 saw the launch of a perfume for women, called “Y.” But Saint Laurent’s new collection was showered with negative criticism. The press spoke only of the André Courrèges’ bombshell collection. Saint Laurent explained: “I have never been able to work on a wooden mannequin; I play by unrolling the fabric on the model, walking around her, making her move. ... The only collection that I made a mess of, a complete fiasco, the very year when Courrèges’s came on the scene and succeeded, I did not have good models, and I was not inspired” (Vacher, p. 68). Still drawn to the theater, he designed the costumes for *Le mariage de Figaro* and *Il faut passer par les nuages* for the Renaud-Barrault company.

In 1965 he triumphed with the Mondrian collection (named for the modern artist Piet Mondrian), which was surprising for its strict cut and the play of colors. Showered with praise by the American fashion press, he had become, according to *Women’s Wear Daily*, “the Young King Yves of Paris.” It was at this time that he made his first trip to New York, accompanied by Bergé. Richard Salomon (of Charles of the Ritz) acquired all the stock of the Yves Saint Laurent design company. At this time, too, Saint Laurent began a long friendship with the dancer Rudolph Nureyev, for whom he designed stage costumes and street clothes. He also created the wardrobe that Sophia Loren wore in Stanley Donen’s film *Arabesque* (1966), as well as the costumes for Roland Petit’s *Notre-Dame de Paris*.

For his summer 1966 haute couture show Saint Laurent presented the first see-through garments, the “nude look,” and the first dinner jacket: “If I had to choose a design among all those that I have presented, it would unquestionably be the tuxedo jacket.... And since then, it has been in every one of my collections. It is in a sense the ‘label’ of Yves Saint Laurent” (Vacher, p. 64). For his haute couture collection of winter 1966–1967 he introduced the Pop Art collection. He met Andy Warhol and Loulou de la Falaise, his future muse. On 26 September 1966 Saint Laurent opened his first ready-to-wear shop, Saint Laurent Rive Gauche, at 21, rue de Tournon, with Catherine Deneuve, for whom he had designed the costumes in Luis Buñuel’s film *Belle de jour* (1967), as godmother.

With the designs of Saint Laurent, ready-to-wear fashion established its pedigree, for he himself supervised the creation, manufacture, and distribution of the clothing: “The ready-to-wear is not a poor substitute for couture. It is the future. We know that we are dressing younger, more receptive women. With them it is easy to be bolder” (Benaïm, p. 153). That same year he won the *Harper’s Bazaar* Oscar award; published an illustrated book, *La vilaine Lulu*; and launched his so-called African dresses. It was at that time that Saint Laurent and Bergé discovered Marrakesh, where they bought a house. For the spring–summer 1968 show, he presented the first jacket for the safari look, more see-through garments, and the jumpsuit, which would be successfully repeated in 1975. The style “Il” or “He” was born, comprising mini evening dresses and men’s suits: “I was deeply struck by a photograph of Marlene Dietrich wearing men’s clothes. A tuxedo, a blazer, or a navel officer’s uniform—any of them. A woman dressed as a man must be at the height of femininity to fight against a costume that isn’t hers” (Buck, p. 301). In September, the first Saint Laurent Rive Gauche shop was opened in New York. In a television interview, Chanel identified Saint Laurent as her spiritual heir, while galleries in London and New York exhibited his theater drawings.

The autumn–winter 1969 collection was dominated by the tapestry coat, patchwork furs, and jeweled dresses created by his sculptor friends the Lalannes. He continued to work in the cinema, designing costumes for Catherine Deneuve in François Truffaut’s *La sirène du Mississippi* (1969); then, with Bergé, he opened the first Saint Laurent Rive Gauche shop for men at 17, rue de Tournon. In 1971, inspired by the designer Paloma Picasso, who bought her clothes at flea markets, he created the Libération collection, also known as Quarante, which provoked a scandal with its “retro” style. Saint Laurent later said that this collection—featuring puffed sleeves, square shoulders, platform shoes, and his famous green fox short jacket—was a humorous reaction to new fashion tendencies. In its wake, he posed nude for the photographer Jeanloup Sieff to advertise his first eau de toilette for men, YSL pour Homme, provoking another scandal.

Beginning in 1972 great changes took place. Pierre Bergé, whose ultimate aim was to recover all the stock of Yves Saint Laurent, repurchased from Charles of the Ritz (which had become a subsidiary of the American pharmaceutical giant Squibb) its shares in the couture house, thereby taking control of the couture and ready-to-wear businesses. Bergé and Saint Laurent then developed a licensing policy; although it had existed earlier, it was strengthened and enforced. The designs presented in the spring of 1972 (embroidered cardigans, padded jackets, “Proust” dresses with taffeta frills) were greeted triumphantly by a press once again overflowing with praise: “the man is pure and simple, the greatest fashion designer in the world today,” said *Harper’s Bazaar* (March 1972, p. 93). To close the season with a flourish, Andy Warhol did a series of portraits of Saint Laurent.

The following years found Saint Laurent ever more in demand in the world of film and theater. He designed costumes in succession for Anny Duperey in Alain Resnais’s film *Stavisky* . . . , for Ellen Burstyn in the same director’s *Providence*, and for Helmut Berger in Joseph Losey’s *The Romantic Englishwoman*. He created the costumes for the ballets *La rose malade* (1973) and *Schéhérazade* (1974) for Roland Petit; for *Harold and Maude* (1973), a play by Colin Higgins; and for Jeanne Moreau and Gérard Depardieu in *The Ride across Lake Constance* (1974) by Peter Handke. In 1974 an exhibition of his costume and stage set sketches was staged in the Proscenium gallery in Paris. In July of the same year, the couture house moved from its cramped quarters to a Second Empire mansion at 5, avenue Marceau.

In 1976 the Opéra-Ballets Russes collection (homage to the Russian ballet producer Sergey Diaghilev) enjoyed international success and was featured on the front page of the *New York Times*. Saint Laurent, who was celebrating his fortieth birthday, said: “I don’t know if this is my best collection, but it is my most beautiful collection” (August 16, 1976, p. 39). At about this time, Saint Laurent suffered a severe depression, and beginning in 1977 rumors circulated about his impending death. He replied with major colorful collections with exotic themes: the Espagnoles, with dresses straight out of a painting by Diego Velázquez, and the Chinoises, celebrating the annals of imperial China. He also launched a new perfume, Opium, the advertising for which, orchestrated by the Mafia agency, created a scandal with the slogan “For those who are addicted to Yves Saint Laurent.”

In 1978, having just designed the sets and costumes for Cocteau’s *L’Aigle à deux têtes* and for Ingrid Caven’s cabaret show and written the preface for Nancy Hall-Duncan’s book *The History of Fashion Photography* (1979), Saint Laurent demonstrated with his spring-summer collections, “Broadway suits” that he was still in touch with the current climate. He said, “This collection is very elegant, provocative, and at the same time wildly modern, which might appear contradictory. I have sought for purity, but I have interjected unexpected accessories: pointed

collars, little hats, shoes with pompons. With these kinds of winks, I wanted to bring a little humor to haute couture, . . . give it the same sense of freedom one feels in the street, the same provocative and arrogant appearance as, for example, punk fashion. All of that, of course, with dignity, luxury, and style” (Yves Saint Laurent, p. 23).

During the ensuing decade Saint Laurent carried on with his favorite themes—the now classic blazer, dinner jacket, smock, pea jacket, raincoat, pants suit, and safari jacket—while presenting his collections in the form of the homage to various artists and writers. Pablo Picasso, the surrealist poet Aragon, the French poet Guillaume Apollinaire, Cocteau, the French artist Henri Matisse, Shakespeare, the American painter David Hockney, the French artist Georges Braque, the French painter Pierre Bonnard, and the Dutch painter Vincent van Gogh were invoked in turn, inspiring strongly colored garments in which were inscribed the emblematic forms of the painters and the verses of the poets. His creations were “setting static things in motion on the body of a woman,” he said in *Paris-Match* (12 Février 1988, p. 69). The press around the world never stopped singing his praises.

The 1980s were full and rich for Saint Laurent. In 1981 he designed the uniform for the writer Marguerite Yourcenar, the first woman elected to the Académie Française, and launched a men’s perfume, Kouros. The year 1982 was the twentieth anniversary of the founding of his couture house; the occasion was celebrated at the Lido, where he received the International Fashion Award of the Council of Fashion Designers of America.

In 1983 he showed the Noire et Rose collection, introduced the perfume Paris, designed costumes for the play *Savannah Bay* by Marguerite Duras, and enjoyed the opening of the exhibition “Yves Saint Laurent, 25 Years of Design” at the Metropolitan Museum of New York, the largest retrospective ever devoted to a living couturier. One million visitors attended the exhibition, organized by Diana Vreeland. As Vreeland put it, “Saint Laurent has been built into the history of fashion now for a long time. Twenty-six years is proof that he can please most of the people most of the time four times a year. That’s quite a reputation” (*Time*, December 12, 1983, p. 56). That same year he made his appearance in the *Larousse* dictionary.

President François Mitterrand awarded Saint Laurent the medal of Chevalier de la Légion d’Honneur in 1985, the same year the African Look collection debuted. Accompanied by Pierre Bergé, he traveled to China for the exhibition devoted to his work at the Fine Arts Museum of Beijing (which recorded 600,000 visitors) and received, at the Paris Opera, the award for Best Couturier for the body of his work. In 1986 he presented his fiftieth haute couture collection, and a retrospective of his work was given at the Musée des Arts de la Mode in Paris. Bergé and Saint Laurent, with the participation of Cerus, purchased Charles of the Ritz, owner of Yves Saint Laurent perfumes, for \$630 million.

The next year retrospectives were mounted in the U.S.S.R. (Hermitage, Saint Petersburg) and in Australia (Art Gallery of New South Wales, Sydney). That season five hundred of his pieces sold, principally to a foreign clientele. In 1988, Saint Laurent became the first couturier to present a show for the French Communist Party, at the Fête de l'Humanité. Shares of the Saint Laurent group were introduced on the secondary market of the Paris Bourse in 1989, and the revenues of the house of Saint Laurent reached 3 million francs.

The decade of the 1990s began with an exhibition at the Sezon Museum of Art in Tokyo; the opening of the first shop for accessories, at 32, rue du Faubourg Saint-Honoré; and the presentation of the collection Hommages, considered a "farewell" by some of the press. Scandal arose, however, from an interview Saint Laurent gave to *Le figaro*, in which he spoke of detoxification, his homosexuality, his overuse of alcohol, and his fits of nervous depression. But in 1992, like the phoenix reborn from his ashes, he presented his 121st collection, Une Renaissance, and celebrated the thirtieth anniversary of the Saint Laurent fashion house by inviting 2,800 guests to the Opéra Bastille.

In May 1993 the Yves Saint Laurent group merged with the Elf-Sanofi company. With this acquisition, Elf-Sanofi became the third-largest international prestige perfume and cosmetic company, after L'Oréal and Estée Lauder. Saint Laurent then launched the perfume Champagne, "for happy, lighthearted women, who sparkle." On 21 July, he presented his 124th haute couture collection, with models parading to the melody of *The Merry Widow*. In a major spectacle at the Stade de France, for the opening of the 1998 World Cup of soccer Saint Laurent and Bergé paraded three hundred models before a packed stadium, while two billion spectators watched the event on television. In November of that year, in order to devote himself entirely to haute couture, Saint Laurent turned women's ready-to-wear over to Albert Elbaz and men's ready-to-wear to Hedi Slimane.

In 1999 François Pinault, owner of the department store Printemps, bought Saint Laurent from Elf for 1.12 billion euros and pumped in an additional 78 million euros to take control of all rights to the label, which he turned over to Tom Ford, the Texan designer for Gucci, a house also controlled by Pinault. Bergé announced the opening of the Centre de Documentation Yves Saint Laurent, in Paris, planned for January 2000.

After forty-four years of fashion designing, Saint Laurent announced the closing of his house at a press conference given on 7 January 2002. He took his leave of haute couture with these words: "I have always stood fast against the fantasies of some people who satisfy their egos through fashion. On the contrary, I wanted to put myself at the service of women. ... I wanted to accompany them in the great movement of liberation that they went through in the last century. ... I am naïve enough to believe that [my designs] can stand up to the attacks

of time and hold their place in the world of today. They have already proved it."

Saint Laurent fixed the ephemeral and constantly sought beauty, shifting between classicism and provocation. Favoring methodical work, recurrent themes, and improvisations in the form of homages, he referred to other artists as catalysts. Shakespeare, Velázquez, Picasso, Proust, and Mondrian each, in turn, served as an inspiration to him. By pushing to extremes the exoticism of the street and delving into forgotten folk traditions, he brought forth a new spirit that illuminated his palette, for example, in the African, Ballets Russes, and Chinoises collections. In an even more radical shift, he took on the male wardrobe, diverting and transposing the dinner jacket, pants suit, safari jacket, and pea jacket to bring masculine and feminine together in a single design. But, it is Pierre Bergé who best describes Yves Saint Laurent's contribution for Yves—and herein lies his uniqueness—each collection is a means of bringing dreams to life, expressing fantasies, encountering myths, and creating out of them a contemporary fashion" (Saint Laurent, p. 27).

*See also* **Art and Fashion; Ballet Costume; Fashion Shows; Film and Fashion; Haute Couture; Paris Fashion; Perfume; Ready-to-Wear; Retro Styles; Theatrical Costume.**

#### BIBLIOGRAPHY

- Benaïm, Laurence. *Yves Saint Laurent*. Paris: Grasset, 1993.
- Buck, Joan Juliet. "Yves Saint Laurent on Style, Passion, and Beauty." *Vogue* (December 1983): 301.
- Saint Laurent, Yves, Diana Vreeland, et al. *Yves Saint Laurent*. New York: Clarkson N. Potter, Inc., 1983.
- Teboul, David. *Yves Saint Laurent: 5, Avenue Marceau, 75116 Paris, France*. Paris: Martinière, 2002.
- Vacher, Irène. "Lesgens." *Paris Match*, 4 décembre 1981, p. 68.
- Yves Saint Laurent par Yves Saint Laurent, 28 ans de création*. Paris: éditions Herscher, 1986.

*Pamela Golbin*

**SALWAR-KAMEEZ** The *salwar-kameez*, or the Punjabi suit (referred to here simply as "the suit"), has traditionally been worn by women of North India and Pakistan and their sisters who have immigrated overseas. It consists of three separate parts: *kameez* (shirt), *salwar* (trousers, nearly always with *ponchay*, or cuffs, at the ankles), and a *chuni* or *dupatta* (scarf or stole). These three components have remained constant over time, though women might not wear the *chuni* on certain occasions. The *chuni* is nearly always worn inside temples to cover the head. The styles, lengths, and widths of these separate parts vary to suit the fashions of the times.

There has always been, however, a "classic suit" that maintains all the components and changes little over long periods of time. These classic suits are interpreted according to personal idiosyncrasies and tastes. For example, the "Patiala suit" (from the princely state of Patiala in the Punjab, which has old and highly developed tra-



ditions of arts and crafts) is worn by women in that area regardless of caste, class, and religion and has remained the same for many years. It consists of a knee-length kameez, a baggy salwar (much more voluminous than the average salwar), and a long *chuni*. This classic style is distinctive and a widely recognized marker of this region of the Punjab.

The salwar-kameez is also worn by men, especially by Muslim men, in both Pakistan and India, though the men's version is different from its female counterpart. It is possible that the suit's connotations of maleness have played a role in the adoption of the salwar-kameez by Indian women who might once have worn saris, as a result of women's entry into the waged-labor market. In the world of business and commerce, women are asserting their identities through this practical and comfortable outfit, which they consider to be the most suitable garment for the public realms of economic participation. But, of course, the suit has been worn in public domains for centuries by North Indian women, before this dramatic adoption of the suit in the recent past by wage-earning women throughout the subcontinent.

Another facet of the suit's popularity is a result of the professionalizing of its design, both on the subcontinent and in Europe, since the 1980s. Design professionals trained at fashion schools on the subcontinent or in Europe or America have created innovative new styles and silhouettes while relying upon, and helping to revive, old traditions of embroidery, dyeing, and other forms of embellishment. They have thus developed new techniques of making suits using existing craft skills. These new interpretations have led to a dramatic expansion of markets for the salwar-kameez, both on the subcontinent and in such cities as London, Durban (South Africa), Sydney, Los Angeles, New York, Dubai (United Arab Emirates), Nairobi (Kenya), and other centers of diaspora communities. In these markets, suits of all types and levels of quality are sold at a wide range of prices. Designer suits can cost upward of \$9,000, and wedding suits as much as \$20,000. Suits that bear "designer labels" might cost \$300 to \$500, while suits selling for as little as \$30 can be found in street markets. The suit economy, in other words, has become quite elaborate.

The suit in the 1990s and the early part of the twenty-first century emerged as a mainstream high-fashion garment, popular both on the catwalk (in Paris and London) and on the street. In Great Britain it was front-page news when the salwar-kameez was worn by such fashion leaders as Diana, Princess of Wales, and Cheri Booth, wife of British Prime Minister Tony Blair. The suit thus has been reimagined and recontextualized as a "global chic" garment. In London diaspora communities, fashion entrepreneurs have been key agents in moving the suit beyond Indian and "ethnic" markets and into the mainstream. As Asian women residing and raised in London, they are attuned to local design trends, which they incorporate in the suits they create for their customers in a global city.

It is this improvisational sensibility—the *modus vivendi* of their diaspora—that gives them an edge over subcontinental fashion entrepreneurs. They have created new styles that encode their racial politics through their design sensibilities and retail skills. Along with older suit-wearing women, they have transformed what were formerly negatively coded "immigrant ethnic clothes," derided by the mainstream, into the most fashionable border-crossing clothes of our times. The suit is worn by women across ethnic and racial lines in many parts of the world. Black women in London were among the first to wear the suit, much before British women of the upper classes, fashion icons, and the white political elite.

Of course, these suit trends are part of the wider dynamics of the ethnicization and Asianization of Western culture as well as of images created by Asians living in the West, as seen in film, music, literature, and other media. The British Asian diasporic film director Gurinder Chadha's film *Bend It Like Beckham* (2003) has been a phenomenal international success. She is also an innovative hybridizing suit wearer, a savvy image maker with an influential suit style. In Britain, curry has replaced roast beef as the favorite food of the nation. For a younger set of Asians, *bhangra* dance music—a reworking of Punjabi harvest music as interpreted through jazz, reggae, hip-hop, and many other musical genres—was a strong influence in favor of adopting the salwar-kameez and also in introducing this generation to the Punjabi language and cultural scene.

In this complex and multifaceted suit economy, the real heroines are the older women, who wore their "classic suits" despite the cultural and racial odds and regardless of the sartorial terrain in the displaced contexts of the diaspora. These powerful and culturally confident women are the agents of sartorial transmission, who socialized their second-generation daughters to wear the suits on their own terms and according to their design codes. The diaspora daughters of these astute and assertive women have been the pathbreaking fashion entrepreneurs who have created the commercial markets for the suit in cities across the globe and have ushered the salwar-kameez into fashion's mainstream.

See also **Diana, Princess of Wales; Ethnic Dress; India: Clothing and Adornment; Sari.**

#### BIBLIOGRAPHY

- Bhachu, Parminder. *Dangerous Designs: Asian Women Fashion the Diaspora Economies*. New York: Routledge, 2004.
- Freeman, Carla. *High Tech and High Heels in the Global Economy: Women, Work, and Pink-Collar Identities in the Caribbean*. Durham, N.C.: Duke University Press, 2000.
- Kondo, Dorinne. *About Face: Performing Race in Fashion and Theatre*. New York: Routledge, 1997.
- Tarlo, Emma. *Clothing Matters: Questions of Dress and Identity in India*. London: Hurst, 1996.

*Parminder Bhachu*

**SANDALS** The sandal is the simplest form of foot covering, consisting of a sole held to the foot using a configuration of straps. Sandals can be utilitarian and bought from a street vendor in Bombay for a few rupees, or a work of art, designed by Manolo Blahnik and selling for several hundred dollars from a high-end boutique. Sandals have been made from every possible material—wood, leather, textile, straw, metal, and even stone, and have graced every echelon of society in almost every culture of the world.

Sandals are the oldest and most commonly found foot covering worldwide. Archaeological examples, uncovered from the Anasazi culture of the American Southwest, date back 8,000 years. These plaited and woven sandals provided a flexible protective sole and utilized a simple V-shaped strap.

Sandals are most commonly found amongst the peoples of hot climates where searing sands and rocky landscapes, inhabited with poisonous insects and thorny plants, necessitated the development of the most basic form of foot covering. Hot, dry climates generally precluded the use of a closed shoe or boot, something that would develop in colder, wetter climates. However, historically, sandals are not found exclusively among the peoples of hot climates.

In Japan, *geta*, wooden-soled sandals, are worn with fabric socks called *tabi* that keep out wetness and winter's chill. Similarly, natives of Eastern Siberia and Alaska wear fur boots that originated in antiquity as sandals tied over fur stockings. At some time in history, the fur stockings were sewn to the soles, creating a boot, but the sandals' straps remained, sewn into the sole seam and tied around the ankle.

While most sandals made for the global market of the early 2000s are usually manufactured of synthetic or recycled materials, such as tires, some indigenous materials are still employed for local markets. In India, water buffalo hide is commonly used for making sandals or *chappli* for the Indian marketplace. Metal and wood have also been used in India to produce *paduka*, the traditional toe-knob sandals of the Hindu: the soles were often stilted, limiting the surface area of the earth trod, protecting the tiniest and humblest of life forms. Similar stilted wooden-soled sandals can be found in Pakistan, Afghanistan, and as far west as Syria and Turkey, although the knobs are replaced with straps ranging from embroidered fabric to simple twisted fiber loops. Syrian wooden sandals, often inlaid with silver wire and mother-of-pearl, were dubbed *kab-kabs* after the sound they make when being walked in. Although the use of these styles is not influenced by Hinduism, their origins were most assuredly from the Hindu toe-knob sandal.

North African and Middle Eastern nomads developed various inventive sole shapes to allow for better movement in desert terrains. The sub-Saharan Hausa used sandals with large soles that extend well beyond the

foot, while curved soles were utilized in Uganda, and rolled toes were developed in Arabia. In more humid climates, sandals were preferred for their cool breathability. Ancient Aztecs and Mayans of Central America adopted a thick-soled sandal with a protective legging attached at the heel, while the top of the foot and shin remained exposed.

### The Ancient Sandal

Western culture traces the origins of the sandal from ancient Egyptian tombs, the earliest evidence dating from around the period of unification, about 5,100 years ago. A frieze in the Cairo museum depicts the Pharaoh Narmer followed by his sandal bearer, suggesting the sandals were a symbol of the pharaoh's sovereignty. This is underscored by the ancient Egyptian practice of placing the Pharaoh's sandals upon his throne in his absence. Sandals were status-oriented for the elite, beginning with the pharaoh and working down the ranks of society throughout the Egyptian dynastic period, so that by the period of Roman occupation around 30 B.C.E. all but the very lowest of society were permitted to wear footwear.

However, it appears that the wearing of sandals still remained an occasional one, reserved mostly for outdoor wear, especially while traveling. The vast majority of ancient Egyptians never wore footwear. Most Egyptians with status never wore footwear inside the home and in fact it appears that the Pharaoh himself did not regularly wear footwear indoors until the late dynasties, about 3,000 years ago. It is also evident that in the presence of a higher-ranking individual or deity, removing one's sandals exhibited deference.

Sandals were often metaphors for the journey into the afterlife—either real (those worn by the deceased in life) or models made especially for the tomb. The earliest examples dating back more than 4,000 years are most often life-size models made of hard wooden soles, suggesting that in death the objects were symbolic or made available to those who did not wear footwear in life. Newer tombs, aged 2,000–2,500 years, reveal everyday footwear, including styles with coil-woven soles similar to modern *espadrilles*.

When Alexander the Great united the Greeks in the fourth century B.C.E., the resulting society was one of great wealth and leisure that developed the arts, sciences, and sports under a democratic system. The Greeks also developed many different types of sandals and other styles of footwear, giving names to the various styles. Fortunately the Greeks kept thorough records, thereby giving accurate descriptions and references to the various styles of footwear and what those names were. This is indeed fortuitous as archaeological examples of Greek footwear are nonexistent, and historians must work from these descriptions and from those styles portrayed in surviving artwork. There were strict rules as to who could wear what, when, and for what purpose.

Sandals used during the early Roman Empire were very similar to the Greek styles and even followed the same precedents set for restricted use according to the citizen's rank in society. Like the Greeks, the Romans named the various styles, and in fact, "sandal" comes from its Latin name *sandalium*.

As the Roman Empire grew to include all the kingdoms held by Greece and Egypt, the Romans then continued their forays into northern Europe. The *caliga*, a military sandal with a thick-layered leather and hobnail-studded sole was named from the Greek *kalikioi*. The young Caius Caesar was nicknamed Caligula after this style of sandals which he wore as a boy when he would dress up as a soldier to stay in military encampments. The *caliga* protected the feet of Roman centurions on the long marches into northern Europe. However, the northern European climate, with its mud and snow, made it necessary for Roman invaders to adopt a more enclosed shoe style, beginning the decline of the sandal in the classical period.

As the Empire's strength diminished after the second century C.E., so did the quality of manufacture of footwear. Statuary, as this is more plentiful than actual extant examples of Roman footwear shows simple V-straps utilized on sandals. These are far less complex than the strap arrangements in use when the Empire was expanding and at its greatest.

In the seventh century the Christian Roman Empire, based in Constantinople, decreed that bare toes were immodest in mixed company. The sandal all but disappeared for the next 1,300 years, remaining in constant use only in cloistered monastic orders.

Although gone, sandals were not forgotten. Artists portrayed sandal-wearing classical figures in biblically themed frescoes during the Renaissance, and sandals were worn by actors portraying historical figures in theatrical presentations.

### The Fashion Sandal

After the 1789 Revolution, the new French republic looked to ancient Greece and Rome for inspiration; along with classically draped garments, the sandal made a brief return to the feet of fashionable women. By the 1810s, a closed-shoe style, resembling a ballerina's slipper with crisscrossed silk ankle ties, became fashionable, and although no toes were exposed and technically the style was not a true sandal, the long ties did suggest a classical association, and the shoes were commonly referred to in period literature as "sandal-slippers."

The Empress Eugénie is depicted wearing toe-baring sandals in a photograph taken in the 1850s, but this was not to be a successful attempt at re-introducing the sandal as a staple into the fashionable woman's wardrobe. Propriety kept men's and women's toes hidden even on the beach, where bathing sandals consisting of cork-soled cotton closed-toe shoes with crisscrossed laces, first adopted

in the 1860s. Similarly another classical revival in fashions brought about the sandal-boot for women. This was a closed-boot style, but cutouts in the shaft exposed the stocking-clad leg beneath. This style of boot first appeared in the late 1860s and remained fashionable into the early years of the twentieth century.

It was back at the beach in the early twentieth century where bathing sandals and boots gradually bared more of the ankle and instep. During the late 1920s, women donned beach pajamas for the poolside or at the beach. These loose-fitting pantsuits were paired with low-heeled sandals made of wide leather or cotton straps. It was a short jump from poolside to the dance floor in the early 1930s, where under long evening gowns, high-heeled leather and silk sandals permitted feet to remain air-conditioned for long nights of fox-trots and rumbas. By the late 1930s, the sandal was a fully reinstated necessity in a fashionable shoe wardrobe and included styles for all times of day.

World War II inadvertently aided in the re-establishment of the sandal as certain materials, such as leather, were rationed for civilian usage. Sandal straps require less leather in their production than an enclosed pump, and summer sandals made up of twisted and woven fibers and other nonrationed materials were available without coupons on both sides of the Atlantic.

By the 1950s, many European men were wearing sandals for casual wear but most North American men considered them too effete. Women's evening sandals in the 1950s used the barest of straps to give the illusion of no footwear at all, as if the wearer was walking on tip-toe. The vamp strap-sandal style, also known as an open-toe mule, created a similar illusion, although quick steps proved impossible without losing a shoe in the process. American shoe designer Beth Levine solved this issue with the addition of an elastic web running the length of the insole. This innovation was called a *spring-o-later*.

In the late 1960s hippie anti-fashion introduced the most basic sandal style to American streets. Dubbed "Jesus" sandals, these simple leather toe ring or V-strap sandals were imported from Mexico and Asia, or made up locally by fledgling street artisans. Gender neutral, this sandal embraced naturalism, comfort, and ethnic-inspired style. This paved the way for the introduction of "health" sandals into the fashionable wardrobe, such as Birkenstocks in the 1970s. Contoured insoles and minimal curtailing of the foot were touted as perfect aids to foot health and comfort.

While high-fashion sandals have remained a staple in women's wardrobes since the 1930s, men's sandals have never achieved a place beyond the beach and casual wear. However, boundaries have been crossed in recent years. Sport sandals, introduced in the 1990s, transcended the sandal into a foot covering suitable for a variety of sports activities by including a synthetic rubber-treaded sole. And the simplest of colored rubber flip-flop thongs,



intended for basic seaside foot covering, has even made it into the pages of *Vogue* and other au courante fashion publications, gracing the feet of well-dressed models in clothes deemed suitable for a day of shopping on Fifth Avenue or the Champs Élysées.

See also **Boots; High Heels; Shoes; Shoes, Children's; Shoes, Men's; Shoes, Women's.**

#### BIBLIOGRAPHY

- Bondi, Federico, and Giovanni Mariacher. *If the Shoe Fits*. Venice, Italy: Cavallino Venezia, 1983.
- Durian-Ress, Saskia. *Schube: vom späten Mittelalter bis zur Gegenwart Hirmer*. Munich: Verlag, 1991.
- Ferragamo, Salvatore. *The Art of the Shoe, 1927–1960*. Florence, Italy: Centro Di, 1992.
- Rexford, Nancy E. *Women's Shoes in America, 1795–1930*. Kent, Ohio: Kent State University Press, 2000.
- Swann, June. *Shoes*. London: B.T. Batsford, Ltd., 1982.
- . *Shoemaking*. Shire Album 155. Jersey City, N.J.: Parkwest Publications, 1986.
- Walford, Jonathan. *The Gentle Step*. Toronto: Bata Shoe Museum, 1994.

*Jonathan Walford*

**SAPEURS** The words *sape* (*Société des Ambiançeurs et des Personnes Élégantes*) and *sapeurs* are neologisms that were coined by Congolese diasporic youth living in Western metropolises, especially Paris and Brussels, to authenticate and validate their quest for a new social identity through high fashion. The *sape's* history, however, dates back to the first years of the colonial encounter in the Congolese capital cities of Kinshasa and Brazzaville.

As early as 1910, the *sape* was in full bloom in Brazzaville, as several observers complainingly noted. In 1913, French Baron Jehan De Witte demurred at what he thought was “overdressing” among the Brazzaville locals: “[...] on Sunday, those that have several pairs of pants, several cardigans, put these clothes on one layer over the other, to flaunt their wealth. Many pride themselves on following Parisian fashion ...” (p. 164). In an article arguing that colonial subjects encountered European modernity first through fashion, Phyllis Martin notes that in 1920s Brazzaville “men wore suits and used accessories such as canes, monocles, gloves, and pocketwatches on chains. They formed clubs around their interest in fashion, gathering to drink aperitifs and dance to Cuban and European music played on the phonograph” (p. 407). Most of these young people who prided themselves on being unremitting consumers and fervent connoisseurs of Parisian fashion were domestic servants, civil servants, and musicians. They spent their meager wages to order, through catalogs, the latest fashions from France.

The 1950s witnessed the creation of several associations of urban youth, whose main interests seemed to

have revolved around sartorial display. Bars had sprouted in every corner of the Congolese twin capitals, owing to the emergence in the 1940s of Congolese popular rumba. These venues provided a natural platform for the youth.

*Sapeurs* in the early 2000s represent at least the third generation of Congolese dandyism. But what sets them apart from their colonial counterparts is their migratory trajectory to European cities and their social dereliction in countries that adopt discriminatory policies toward Third World immigrants. For these young people, the *sape* therefore becomes a refuge and a vehicle through which to forge new identities away from their chaotic homeland. Before the 1990s, *sapeurs* living in Paris or elsewhere in Europe were conferred this status only by returning to Kinshasa or Brazzaville during their summer vacation to flaunt their wardrobe. With the two countries in the throes of civil war, and given that many of these youth live in Europe without proper and lawful immigrant documents, they are more reticent to go back home and thus are redefining their relationship to their homeland. The *sape* thus allows them to avoid the dreadful connivance of Scylla (sojourn) and Charibdis (return). Although confined to the bottom rung of society, these young people are loyal customers of the most prestigious fashion designers of Paris and sport Cerruti or Kenzo suits that can cost as much as \$1,000 apiece. This said, it would be erroneous to define the *sape* solely as a paradoxical fashion statement. *Sapeurs* justify some of their deviant (such as loud talking in public places), sometimes delinquent (cheating public transportation) attitudes by arguing that they are making the French and the Belgians pay for colonization (the colonial debt). *Sapeurs* from Congo-Kinshasa could be said to have reacted against Mobutusese Seko's longtime ban on Western suits (and ties) by adopting a more exuberant form of *sape*. On the other hand, those from Congo-Brazzaville, predominantly southern Balaris, have used the *sape* to oppose the northerners (in power since 1969), whom they accuse of squandering the country's wealth by building lavish mansions and buying expensive cars. Indeed, these political attitudes remain inseparable from the hedonistic quest for perfection through fashion and speak to the ways African youth are attempting to negotiate and shape the marginal situation they have been confined to within the global village.

See also **Africa, Sub-Saharan: History of Dress; Paris Fashion.**

#### BIBLIOGRAPHY

- Bazenguissa, Rémy. “Belles maisons’ contre S.A.P.E.: Pratiques de valorisation symbolique au Congo.” In *État et société dans le Tiers-Monde: de la modernisation à la démocratisation*. Edited by Maxime Haubert et al. Paris: Publications de la Sorbonne, 1992, pp. 247–255.
- , and Janet MacGaffey. “Vivre et briller à Paris. Des jeunes Congolais et Zaïrois en marge de la légalité économique,” *Politique africaine* 57 (March 1995): 124–133.

- , and Janet MacGaffey. *Congo-Paris: Transnational Traders on the Margins of the Law*. Bloomington: Indiana University Press, 2000.
- Friedman, Jonathan. "The Political Economy of Elegance: An African Cult of Beauty." *Culture and History* 7 (1990): 101–125.
- Gandoulou, Justin-Daniel. *Entre Bacongo et Paris*. Paris: Centre Georges Pompidou, 1984.
- . *Dandies à Bacongo. Le culte de l'élégance dans la société congolaise contemporaine*. Paris: L'Harmattan, 1989.
- Gondola, Ch. Didier. "Popular Music, Urban Society, and Changing Gender Relations in Kinshasa, Zaire." In *Gendered Encounters: Challenging Cultural Boundaries and Social Hierarchies in Africa*. Edited by Maria Grosz-Ngaté and Omari H. Kokole. London and New York: Routledge, 1996, pp. 65–84.
- . "La contestation politique des jeunes à Kinshasa à travers l'exemple du mouvement 'Kindoubill' (1950–1959)." *Brood und Rozen, Tijdschrift voor de Geschiedenis van Sociale Bewegingen* 2 (January 1999): 171–183.
- . "Dream and Drama: The Search for Elegance among Congolese Youth." *African Studies Review* 42 (April 1999): 23–48.
- . "La sape des *mikilistes*: théâtre de l'artifice et représentation onirique." *Cahiers d'études africaines* 153, no. 39-1 (1999): 13–47.
- . "La Sape: Migration, Fashion, and Resistance among Congolese Youth in Paris." *Elimu. Newsletter of the University of California, San Diego African and African-American Studies Research Project* 4 (Summer/Fall 2000): 4, 12.
- Phyllis, Martin. "Contesting Clothes in Colonial Brazzaville." *Journal of African History* 35 (1994): 401–426.
- . *Leisure and Society in Colonial Brazzaville*. Cambridge, New York: Cambridge University Press, 1995.
- Thomas, Dominic. "Fashion Matters: La Sape and Vestimentary Codes in Transnational Contexts and Urban Diasporas." *Francophone Studies: New Landscapes, Modern Language Notes* 118 (September 2003): 947–973.
- Witte, Baron Jehan de. *Les deux Congo*. Paris: Plon, 1913.

Ch. Didier Gondola

**SARI** The word "sari" has come into general use to cover a generic category, including any draped untailed textile of about five meters in length, worn by the women of South Asia. In common parlance outside the region, the term "sari" refers to an increasingly standardized form of drape. More urban and cosmopolitan women have adapted the Nivi style, but this drape is a relatively new phenomenon. In India alone, around a hundred other forms of drapes continue to be worn. These vary from the eight-yard Koli drape of fisherwomen in Maharashtra to the thrice-wrapped drape of Bengal.

There is a general belief that the sari as a draped and seamless garment is the contemporary representative of the traditional female attire of Hindu South Asia that became diluted by the introduction from the North of tai-

lored and stitched garments under the influence of Islam. Historical and archaeological sources do not support this reading, however. Representations on statues, wall paintings, and other sources suggests that for as far back as there are records, women in the South Asia area wore a wide variety of regional styles that included both stitched and unstitched garments, tailored and untailed. Indeed in the twenty-first century, a sari is as likely to be associated with Muslim women in the Bengal region as Hindus in the South of India. Furthermore, the seamless piece of cloth of the sari is increasingly worn along with two stitched garments, a full-length underskirt tied at the waist with a drawstring, and a fitted waist-length blouse done up at the front. The sari itself covers little of the body that is not already hidden by these accompanying garments, although conceptually a woman would see herself as unclothed without the final addition. Most women also wear underwear to make a third layer of clothing.

In the latter half of the twentieth century, the emergence of the Nivi style of draping the sari may be attributed to middle-class women entering the public sphere during the struggle for independence. It was considered more suitable to public appearances and greater mobility. This style consists of the sari being wrapped around the lower body with about a meter of cloth pleated and tucked into the waist at the center and the remainder used to cover the bosom and then falls over the left shoulder. The loose end of the sari that hangs from the shoulder is known as the *pallu*. Younger and less confident women or those wearing the sari as a uniform (such as nurses, policewomen, or receptionists) usually pin the *pallu* to their shoulder in carefully arranged pleats. As a result of the development of this pan-Indian cosmopolitan drape of the sari, the influence of local regional traditions of draping has declined in urban spaces and has become either confined to being worn within the home or in rural areas. The Nivi style of wearing the sari was further popularized through its increased association with other pan-Indian phenomena, such as the film industry and national politicians. As a result this has become the style that is symbolic of India as a state and women's sense of themselves as Indian (although it may also be found more widely in South Asia, in Bangladesh and Nepal). As a result of this development, women in areas of India where the sari was not traditional garb adopted the sari for specific formal occasions such as weddings and important public events.

Saris can be made of natural or synthetic fibers, and can be woven on hand looms or power looms. Natural fibers such as silk and cotton, which are also more fragile, are worn mostly by middle- and upper-class women. They are named after the regions in which they are made such as Kanchipuram, Sambhalpur, or Kota. Each style is associated with particular weaves, motifs, and even colors. Some saris can be very ornate and may include real gold wash on silver thread (*zari*) in their embroidery (though most *zari* work in the early 2000s is nonmetal).

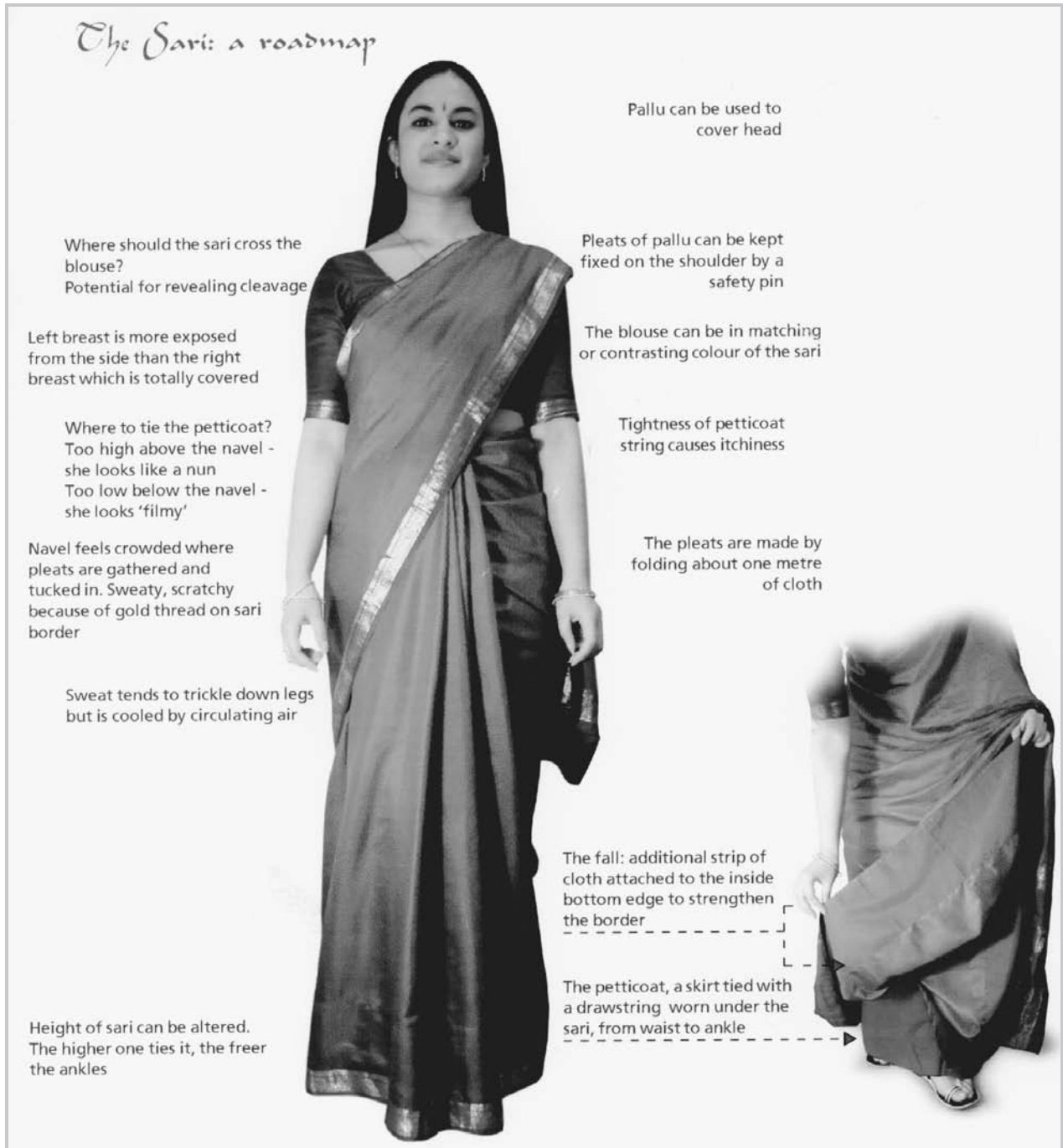

**The sari.** The sari is a versatile garment worn by women throughout South Asia. The *Nivi* style shown here is the most familiar to the rest of the world, but many other styles are in use. COURTESY OF DIXIE. REPRODUCED BY PERMISSION.

Other varieties may include highly elaborate embroidery styles such as *chikan* work from Lucknow. These saris may cost hundreds of dollars and are often associated with the glamour attached to the Bollywood (the film industry based in India) and politicians such as Indira Gandhi who is famous for having chosen her wardrobe carefully

to reflect aesthetic taste and populist appeal. Hand-loom saris are adopted by women not only for their traditional designs and beauty but also as a statement of support for the threatened cottage industry of weaving.

However, the vast majority of saris worn by working women in the early 2000s are made of synthetic materials.



While the yarn is largely spun in major mills, the large mills make up only around 4 percent of sari production (hand-loom make up around 9 percent); the rest are the product of a vast, largely unregulated, power-loom sector, that varies from a couple of machines in someone's home to factory units consisting of two hundred looms, to whom the mill sector subcontracts the weaving process. By far the main fashion influence in the early 2000s upon these synthetic saris is the rise of television soap operas and films. Typically a market or shop includes saris that have labels attached associating them with particular characters from popular culture.

The sari is not worn by young girls anywhere in India. Girls tend to wear what are locally called frocks. Traditionally, wearing the sari was associated with puberty, but many regions have specific clothing associated with adolescence, such as the half-sari or *salwaar-kameez*, and these have grown in importance as fewer girls are married at puberty. Many mothers of girls start to collect saris from an early age, building up toward a wedding trousseau. The high point of sari wearing is commonly the wedding itself, which is (given sufficient resources) a series of events each demanding a particular sari. The color of the sari worn by the bride for the main ceremony is strictly prescribed and can vary from red in the north and east to white in Kerala. The wedding is also the occasion for much sari gifting among relatives of the bride and groom.

The period immediately after the wedding is usually the time when women are most likely to wear a sari in exclusion to all other types of clothing. As a new bride she is expected to sport the most expensive, dazzling, and bright saris. Through her years as a married woman and mother, the bright colors of her sari are expected to reflect the fecundity of her life. With age, however, the widow or elderly woman is expected to wear mainly simple and less elaborate saris. There is a cosmological significance to this shift in which the fading of the sari stands for the gradual detachment from an interest in and engagement with material things in general and with the specificity of a particular person and their occupation.

The sari as a possession is strongly correlated with wealth. Most village women keep their saris in a small trunk. They may have only one or two working saris that they wear on a daily basis, with another two or three better-quality saris kept for special occasions, such as weddings or visits to town. Some have even less than this number and most village women obtain the bulk of their saris as gifts associated with particular occasions, such as festivals. Poorer women may hardly buy any saris themselves during their lives. By contrast, middle-class salaried women in the towns may possess two or three hundred saris, often kept in steel cupboards, which reflect a wide spectrum of colors and styles. Many of these may also be gifts and are associated with particular relationships and events.

A more intimate examination of the consequences of wearing the sari demonstrates that there may be profound differences in the experience of wearing a sari as compared to wearing western dress. The existence of the *pallu* as a loose-end that comes over the shoulder and is then available to be manipulated in a wide variety of ways means that the relationship of women to their clothing can often take on a much more dynamic form. For example, most women are expected to appear in a particularly modest, if not veiled, manner in relation to various contexts, such as the presence of certain male relatives. Covering one's head with the *pallu* is a common response. Urban women, who are not subject to such restrictions, may be seen using the *pallu* to constantly change their appearance, for example, by tucking it into the waist to express anger or allowing it to reveal the bosom in order to flirt. The *pallu* is also very important in establishing key relationships, such as those between mother and child. The *pallu* may be used as a cradle, as a support to the child in learning to walk, and as a kind of "transitional object" that helps the child to separate from the mother into an independent person. This ability to manipulate one's clothing during the day and not be constrained by choices made when getting dressed in the morning makes the sari more of a companion in playing out a number of different social roles. This flexibility is what makes the sari a perfect garment to inhabit the multiplicity of roles which modernity brings to women's lives.

In areas of India where the sari was ubiquitous, women of the early 2000s are turning to alternative attire, especially the *salwar-kameez*, which is considered a more informal garment and thought better suited to commuting and work. In rural areas, the association of the *salwar-kameez* with the educated girl has given it more progressive connotations and has led to an increased availability and acceptance of this garment even in the heartlands of sari-wearing areas, such as Tamil Nadu and West Bengal.

In summary, the significance of sari wearing as opposed to other available options in South Asia lies in the dynamism and ambiguity that is the defining characteristic of the garment. While this has left open a niche which is being increasingly colonized by the *salwar-kameez* as a "functional" garment associated with educational values and rationality, the combination of the two has in the early 2000s effectively prevented the adoption in South Asia of western dress, which is mainly worn by a small number of elite or by unmarried women.

See also **India: Clothing and Adornment; Textiles, South Asian.**

#### BIBLIOGRAPHY

- Banerjee, Mukulika, and Daniel Miller. *The Sari*. Oxford: Berg, 2003.
- Boulanger, Chantal. *Saris: An Illustrated Guide to the Indian Art of Draping*. New York: Shakti Press International, 1997.
- Chishti, Rta Kapur, and Amba Sanyal. *Saris of India: Madhya Pradesh*. New Delhi: Wiley Eastern, 1989.

Ghurye, Govind Sadashiv. *Indian Costume*. Bombay: Popular Book Depot, 1951.

Lynton, Linda, and Sanjay K. Singh. *The Sari: Styles, Patterns, History, Techniques*. New York: Harry N. Abrams, 1995.

*Mukulika Banerjee and Daniel Miller*

**SARONG** The *sarong* is a wrapper sewn together into a tube. Both men and women in Indonesia and other parts of Southeast Asia wear it. In Indonesia the sarong is an item of everyday dress as well as an essential component of formalized ethnic dress. It is made in a variety of fabrics, including woven plaids, batik, warp ikats, songkets, or silk plaid and/or silk weft ikats. Hollywood's appropriation of the sarong has imbued it with exotic and erotic overtones and reinterpreted it as a wrapper rather than a tube. As a result, in the Western hemisphere the sarong has come to be defined in popular usage as a cloth wrapper, not as a tube.

The Southeast Asian sarong is typically made of mill-woven cloth and is about 100 centimeters high and up to 220 centimeters in circumference. The wearer steps into a sarong, secures it at the hip (or under the arms, a variant for women) either by lapping both ends to meet in the center or by pulling the sarong taut at one side of the body and lapping the remaining fabric to the front, and then rolling the top down and tucking it in or tying the ends in a knot. In this way, hip to ankle are covered.

As a multipurpose garment, the sarong is worn in other ways as well. For women it might be secured under the arms to sleep in or to walk to the river for a bath. Male laborers in T-shirts and shorts hike it at their hips or wear it over their shoulder like a sash when working, only to wear it about their legs on the return home. Enveloped about a person, the sarong serves as a blanket against cool nights.

### Origin of the Sarong

The sarong was the dress of the seafaring peoples of the Malay Peninsula near Sumatra and Java; according to Gittinger, it was subsequently introduced on the island of Madura and along the north coast of Java. In the late nineteenth century, an observer recorded its absence in the Java interior. Early sea traders in these waters were Moslems from India, and Islam spread from the coastal areas, so it is thought that these early sarongs may have been woven plaids, which were associated with Moslem men.

What makes the cloth produced for sarongs unique is the decorative panel (*kepala*, head) that contrasts with the rest of the fabric (*badan*, body), seen at the front when lapped over and secured. In a plaid, this panel may vary in color and/or weave.

One of the earliest panel configurations in batik sarongs of the north coast of Java and Madura is two rows of triangles (*tumpal*) whose points face each other.

Traders brought chintzes from the Coromandel Coast of eastern India whose ends were rows of triangles. When sewn together, this created what is now the *kepala*, and eventually the two bands of triangles were positioned as a set at the end of the pre-sewn batik sarong. The *tumpal* motif is found on gold thread *songkets* of Sumatra and triangle end borders are seen in ikats, perhaps an influence from Indian chintzes.

In the clothing traditions of Java and adjacent western Indonesian islands, the sarong is an alternative to the *kain* (cloth wrapper). North coast batik sarongs are noted for their floral bouquet *kepala* and exuberant colors. At the turn of the twentieth century, Eurasian batik makers experimented with new chemical dyes and motifs, and the thigh-length jacket blouse (*kebaya*) worn with the sarong was shortened to hip length to better show off the *kepala* panel. The sarong is not as long as the *kain panjang* (long, cloth wrapper) batiks of court traditions of Yogyakarta and Surakarta in central Java. The *kain panjang* batiks are of an overall pattern, without a *kepala* panel; they are usually made with subdued colors such as browns, indigos, creams, and whites. When wrapped about the lower body, the end might be fan-folded in tight pleats, or with a loose drape.

The sarong varies in size and material. In all of Indonesia's twenty-six provinces, there are representative forms of ethnic dress in which sarongs, worn with a sleeved upper garment, figure prominently. In southern Sulawesi the Buginese silk sarong is extra wide. In Maluku sarongs are layered, the first one is long, and the second one is folded and worn at the hips, often revealing a *tumpal* motif. In Rote, the handwoven warp ikat sarong is narrow and tall; it is about twenty-five inches in circumference and would almost conceal the wearer's head. Here, the sarong is secured at the breasts and the excess folded over, and secured again at the waist with a belt. Another ikat (not a sarong) would be draped over the woman's shoulders. Generally speaking, the overall silhouette was tubular.

### International Appropriation of Sarong

The sarong as appropriated by Hollywood bears little resemblance to the original. Hedy Lamarr in *White Cargo* (1942) and Dorothy Lamour in *Road to Bali* (1952) both wear wrappers (more like pareos), tied at the side in a way that emphasizes, rather than concealing, the curve of the hips. We know that what the actresses are wearing is a "sarong," because in *Road to Bali* Bob Hope specifically refers to Lamour's wrapper by that term. The draped, lapped frontal portion creates a diagonal line revealing the actress's entire leg. Both protagonists wear form-fitting tops baring midriff and shoulder, bangles, heavy necklaces and earrings. Lamarr and Lamour are seated in languorous poses to show off even more skin. The sarong here is a presentation of exotic femininity that is meant to titillate the western film audience. While *White Cargo* is set in Africa and *Road to Bali* is set in Indonesia on an unnamed island near Bali, the specifics of

place and culture are immaterial. Tondelayo (Lamarr) and the Princess (Lamour) are not “natives,” but rather a nebulous mixture of the Western and the “other.” They conform to western ideals of beauty and allure, while the “ethnic” dress they wear is a fabrication of Hollywood costume designers, unrelated to anything attested in the anthropological record. What is depicted is the “East” as orientalized by the West.

According to Jones and Leshkovich, “Oriental” elements of clothing and decorative arts became part of the Western retail lifestyles markets in the 1990s at a time when Asian economic prowess was on the rise. The fashionable sarong as interpreted by Western fashion designers followed Hollywood’s imagined version of the sarong as a knee- or thigh-length wrapper, tied at the side. Indonesian fashion designers, participating in self-orientalizing, also offered these Western-interpreted sarongs to cosmopolitan Indonesian women. Clearly, for these designers the sarong now referred to two kinds of dress, one local and one global, where the global one was an orientalizing of the local.

*See also Asia, Southeastern Islands and the Pacific: History of Dress; Ikat; Kain-kebaya.*

#### BIBLIOGRAPHY

- Achjadi, Judi. *Pakaian Daerah Wanita Indonesia [Indonesian Women’s Costumes]*. Jakarta, Indonesia: Djambatan, 1976.
- Djumena, Nian S. *Batik dan Mitra [Batik and its Kind]*. Jakarta, Indonesia: Djambatan, 1990.
- Elliot, Inger McCabe. *Batik: Fabled Cloth of Java*. New York: Clarkson N. Potter, Inc., 1984.
- Gittinger, Mattiebelle. *Splendid Symbols: Textiles and Tradition in Indonesia*. Washington, D.C.: The Textile Museum, 1979.
- Jones, Carla, and Ann Marie Leshkovich. “Introduction: Globalization of Asian Dress.” In *Re-Orienting Fashion: The Globalization of Asian Dress*. Edited by Sandra Niessen, Ann Marie Leshkovich, and Carla Jones. Oxford: Berg Press, 2003.
- Taylor, Jean G. “Costume and Gender in Colonial Java.” In *Outward Appearances: Dressing State and Society in Indonesia*, edited by Henk Schulte Nordholt. Leiden: KITLV Press, 1997.

*Heidi Boehlke*

**SATEEN.** *See Weave, Satin.*

**SAVILE ROW** Savile Row is a typical central London street of fairly modest eighteenth- and nineteenth-century brick town houses mixed with late twentieth-century developments. It stretches from Vigo Street in the south to Conduit Street in the north, running parallel with Regent and New Bond Streets. Sitting at the heart of the city’s West End luxury shopping district, the Row is particularly famous as the center of the British bespoke tailoring trade.

The Row traces its beginnings back to the late seventeenth century when Richard Boyle, the first Earl of Burlington, acquired a mansion on nearby Piccadilly (now Burlington House, home of the Royal Academy). Burlington protected the privacy of his estate by buying up the surrounding land, which was eventually developed by his descendant, the enlightened third Earl from the 1730s on. Savile Row was one of the resulting streets of genteel residences, which were generally rented by members of the nobility and affluent professionals who formed part of the new fashionable trend for living “in town” during the social season. The aristocratic atmosphere of the Row was an important component of its rise as a center of style. Its residents required expensive and well-made goods that befitted their rank, and thus attracted the attention of manufacturers and traders in luxury commodities. The high proportion of top-rank military and medical men living in the district also ensured that the provision of smart uniforms and civilian suits were prominent in this commercial expansion.

By the early nineteenth century, the Row had become synonymous with the London-based dandy craze, popularized by personalities such as Beau Brummel, and several ambitious tailors were establishing their reputations in nearby streets. Henry Creed and Meyer & Mortimer for example, were based in Conduit Street, with a rapidly expanding customer-base, thanks to the demand for uniforms initiated by the Napoleonic Wars. The first major incursion of tailoring into Savile Row itself was made by Henry Poole in the late 1840s. A few smaller tailors had opened workshops there in the 1820s, but Poole’s were of a different order. They enjoyed the custom of high-profile clients, including royalty, statesmen, sporting stars, and literary and theatrical celebrities, and put unprecedented effort into the design of their showrooms and marketing ventures. Arguably it was Poole who established the international fame of the Row as a “Mecca” for men’s fashion (though like most tailors he also fitted women with riding outfits and “tailor-mades”).

Through the remainder of the Victorian age and into the twentieth-century, Savile Row shifted its character from that of a residential enclave to a thriving street of tailoring concerns. Distancing themselves from the sweated trades that were providing the mass-manufactured suits of the modern office worker, the tailors of the Row prided themselves on their mastery of traditional handcrafts, the quality of their textiles, and their attention to the individualized needs of their customers. Savile Row firms also came to be associated with a particularly English “look”: restrained, narrow shouldered with a long waist; though each company pioneered a subtly differentiated version of the Savile Row staple. Huntsman, for example, was known for their heavy tweed sporting jackets while Gieves provided a sleek naval cut. By the mid-twentieth century, tailors such as Davies, Kilgour, and Anderson & Sheppard pioneered a more glamorous version of Savile Row style through their fitting-out of fashion leaders such as the



Duke of Windsor and Hollywood stars including Cary Grant and Fred Astaire. This greater attention to “fashion” was also marked by the presence of couturier Hardy Amies in the street from 1945. The Row had adapted following the decline of the British Empire from its role as Imperial outfitter to a new incarnation as the epitome of urbane sophistication.

The final decades of the twentieth century saw further flowerings of talent on Savile Row. Echoing the explosion of boutique culture on Carnaby Street and the King’s Road in the 1960s, Tommy Nutter and Rupert Lycett Green of Blades introduced the Row to styles that were well suited to the culture of Swinging London, a phenomenon brought to the heart of the Row by the arrival of the Beatles’s management company, Apple, at number 3 in 1968. And in the 1990s and 2000s, the association of the Row with “cool” was reinforced once more by the innovations of a new generation of tailor/retailers, including Ozwald Boateng, Richard James, and Spencer Hart who attracted a younger, less hide-bound clientele to their bright and airy emporia. Thus, it can be seen that Savile Row has been highly adaptable to the vagaries of styles in clothing and social trends, maintaining its reputation for traditional manufacturing methods while subtly embracing the challenges of novelty. It is still the premier street in the world for male fashion aficionados.

See also **Boutique; Dandyism; London Fashion; Tailoring.**

#### BIBLIOGRAPHY

Breward, Christopher. *The Hidden Consumer: Masculinities, Fashion and City Life 1860–1914*. Manchester, U.K.: Manchester University Press, 1999.

———. *Fashioning London: Clothing and the Modern Metropolis*. New York: Berg Publishers, 2004.

Chenoune, Farid. *A History of Men’s Fashion*. Paris: Flammarion, 1992.

Walker, Richard. *The Savile Row: An Illustrated History*. New York: Rizzoli, 1989.

*Christopher Breward*

**SCARF** Scarves have been an enduring fashion accessory for hundreds of years, ranging from humble bandannas to luxurious silks. Worn by women around the neck or as a head cover, scarves protect modesty or promote attention. Using basic shapes of cloth, typically triangular, square, or rectangular, scarves lend themselves to a wide variety of ornamentation. Scarves are commonly printed, but the techniques of weaving, batik, painting, and embroidery are also used to create scarf designs. While the scarf’s popularity has fluctuated throughout its history, in certain decades of the twentieth century scarves were essential fashion items, glamorized by dancers, movie stars, socialites, fashion illustrators, and photographers. Scarves accentuate an outfit, provide cov-

ering for the neck or head, and serve as a canvas for decorative patterns and designers’ names.

In eighteenth-century Western fashions, bodices were cut revealingly low, requiring a piece of cloth, known as a fichu, to cover a woman’s chest. Worn around the neck and crossed or tied at the bosom, fichus were either triangular or square in shape. Fichus were often made of white cotton or linen finely embroidered in whitework; others were of colored silks with rich embroidery. This style of scarf continued into the early nineteenth century, but as fashions shifted, chests were covered by bodices and large shawls predominated as accessories.

The scarf as a modern fashion accessory was defined in the early decades of the twentieth century. Flowing lengths of silk worn draped about the body had been made fashionable, in part, by dancers such as Isadora Duncan. That Duncan’s death was caused by a long scarf wound around her neck becoming caught in the wheels of a Bugatti is one of the scarf’s morbid associations. Throughout the 1920s and 1930s, the scarf was incorporated into the sleek, elongated fashions of these decades. As seen in numerous fashion illustrations and photographs of this period, the scarf served as both a sensuous wrap and a geometric design element.

In the course of the twentieth century, the scarf’s viability as a blank canvas on which to present elaborate designs, advertising, humorous motifs, and artists’ creations was used to advantage. The idea of printing scarves and handkerchiefs to commemorate heroes, political events, inventions, and other occasions began in the late eighteenth century and was popular throughout the nineteenth century. This use continued into the twentieth century, with scarves commemorating world’s fairs, political campaigns, cities, tourist attractions, and numerous other themes. Fashion designers employed the signed scarf as a means to accessorize their clothing and promote their names. As licensing became an established part of the fashion industry, designers names on scarves became a lucrative sideline.

Various well-known firms and designers have contributed to producing chic and collectible scarves. Hermès began printing silk scarves with horse motifs in 1937; in the 1940s, the English textile firm of Ascher commissioned artists Henry Moore, Jean Cocteau, and others to create designs for scarves; during the heyday of scarf wearing in the 1950s, Americans Brooke Cadwallader and Vera and Tammis Keefe set the tone for decorative scarves with whimsical and playful motifs; and 1960s fashions were often accentuated with scarves by Emilio Pucci, Rudi Gernreich, and other designers of the period. While the wearing of scarves has diminished with the twenty-first century, the scarf remains a versatile accessory, its connotations ranging from the chic to the matronly depending on the scarf and the wearer’s aplomb.

See also **Gernreich, Ruci; Pucci, Emilio.**

## BIBLIOGRAPHY

- Baseman, Andrew. *The Scarf*. New York: Stewart, Tabori and Chang, 1989.
- Mackrell, Alice. *Shawls, Stoles and Scarves*. London: B. T. Batsford, Ltd., 1986.

*Donna Gbelerter*

**SCARIFICATION** Scarification, also known as cicatrization, is a permanent body modification that transforms the texture and appearance of the surface of the skin (dermis). Although scarification operates as a controlled injury, it is not the result of an accident or health-related surgery. Branding, cutting, and some tattoo practices are types of scarification. In the practice of scarification the dermis and epidermis of the skin are cut, burned (see Branding), scratched, removed, or chemically altered according to the desired designs, symbols, or patterns. The result is a wound, which when healed creates raised scars or keloids that are formed on the skin's surface from increased amounts of collagen. Persons with darker skin tones have typically chosen scarification designs, because scars and keloids are more visible than tattoos.

**Historic Scarification**

The earliest evidence of scarification is the archaeological site at Ain Ghazal, in Jordan, where two headless figurines of Paleolithic (8000 B.C.E.) fertility goddess statues were found with thick scarification lines curving around the buttocks and abdomen. The Sahara rock painting (c. 7000 B.C.E.) at Tassili N'Ajjer at Tanzoumitak, Algeria, also depicts scarification on the breasts, belly, thighs, shoulders, and calves of a Horned Goddess. Similar scarification designs as depicted on the figurines and paintings have been found on females from West and Central Africa.

The significance of the scarification process and resulting scars varies from culture to culture. Historically, scarification has been practiced in Africa, Australia, Papua New Guinea, South America, Central America, and North America. Among the cultural groups in these areas scarification has been used to emphasize the permanency of social and political roles; ritual and cultural values; rites of passage and age-grades; eroticizing the body; promoting sexual attraction and enhancing sexual pleasure; group and cultural identity; spiritual relationships; and aesthetic values. It has also been used as part of medicinal and healing rituals, as well as demonstrating the ability to endure pain. As a result of changing cultures and globalization, most of these scarification practices have been outlawed or banned by local governments.

**Contemporary Scarification**

In the twentieth and twenty-first centuries, Western microcultures, such as the modern primitives and punks, as well as fraternities and sororities, practice scarification. Scarification among these cultural groups varies in sig-

nificance, such as group identity, personal identity, rite of passage, spiritual belief, and connection to tribal cultures. These microcultures utilize a variety of methods of scarification, such as cutting, packing, ink rubbings, skinning, abrasion, and chemical agents to acquire desired scarification patterns or designs.

**Cutting.** Cutting is a form of scarification that involves cutting the surface of the skin with a sharp instrument, such as a sharpened bone, small medical scalpel, or razor blade, called a scarifier. Contemporary cutting tools may be either single-piece disposable units or blades that can be mounted on an assortment of handles. Cuts are about one-sixteenth of an inch deep; deeper cuts increase the amount of scarring and the chances of complications, while shallow cuts may heal without scarring, negating the purpose of the modification.

**Emphasizing scars.** Maintaining an open wound by repeatedly re-cutting the healing skin will result in a more pronounced scar; it will also delay the healing process and may result in serious health-related complications. Packing also creates more pronounced scars by introducing inert substances, such as ashes or clay, into the open incisions or lifting cut areas of skin and allowing the scars to heal around or over it. While cicatrization can refer to any scar, it is usually used in connection with more pronounced scars resulting from packing.

Ink rubbing is a cutting in which indelible tattoo ink or other pigment is rubbed into a fresh cut. The ink remains in the cut as it heals, resulting in a colored scar. Although the intensity varies from person to person, this method creates more visible scars for lighter skin tones.

**Skinning.** Skinning is a common method used to create large areas of scarification. An outline of the designated area to be scarred is cut. Then the scarifier or a lifting tool is placed under the surface of the skin to lift and remove it in manageable sections. An alternative skinning method, to increase the scarring, is to pack inert materials under the lifted skin and allow it to heal. The healing process is lengthy and complications may occur. This method creates large and more precise scarification areas.

**Abrasion Scarification.** Abrasion scarification is achieved by using friction to remove the dermis layers of skin to create scarring. Power tools equipped with sandpaper, steel wool, or grinding stones are a few of the instruments employed to create abrasion scarification. Abrasion scarification can also be achieved with manual pressure, but power tools expedite the process. This method creates subtle scars, unless excessive pressure is applied with the abrasion scarifier.

**Chemical Scarification.** Chemical scarification uses chemical compounds, such as liquid nitrogen, to damage and burn the skin, which results in scarring. Intricate designs are difficult to achieve with liquid chemical agents, otherwise the results are similar to other types of scar-

fication. This method is relatively new and there is little research on it.

**Scarification Risks.** As with most permanent body modifications, scarification has been associated with aesthetic and health-related risks. The resulting appearances of the scars vary, because there are so many variables in the healing process. Scarification may take a year to completely heal, and longer if skinning or packing is involved. During the initial healing process diligent care is necessary in order to avoid infections.

Additional health-related risks include improper technique, such as cutting too deep, or acquiring blood-borne infections such as hepatitis B and C. Appropriate measures should be taken by scarification practitioners to assure the health and safety of their clients. Equipment and instruments that will be used for more than one client are sterilized in an autoclave, a high temperature steamer that kills blood-borne pathogens and bacterial agents. The area of skin to be scarred is disinfected and prepared by the scarification practitioner. During the scarification process, the skin is continually cleaned of excess blood and is disinfected.

See also **Body Piercing; Branding; Modern Primitives; Tattoos.**

#### BIBLIOGRAPHY

- Beck, Peggy, Nia Francisco, and Anna Lee Walters, eds. *The Sacred: Ways of Knowledge, Sources of Life*. Tsailie, Ariz.: Navajo Community College Press, 1995.
- Bohannon, Paul. "Beauty and Scarification among the Tiv." *Man* 51 (1956): 117–121.
- Camphausen, Rufus C. *Return to the Tribal: A Celebration of Body Adornment*. Rochester, Vt.: Park Street Press, 1997.
- Rubin, Arnold, ed. *Marks of Civilization: Artistic Transformation of the Human Body*. Los Angeles: Museum of Cultural History, University of California, 1988.
- Vale, V. *Modern Primitives: An Investigation of Contemporary Adornment and Ritual*. San Francisco Re/Search Publications, 1989.

Theresa M. Winge

**SCHIAPARELLI, ELSA** The Italian-born Elsa Schiaparelli (1890–1973) was in many ways an outsider, yet one who successfully made her way to the heart of French haute couture in the interwar years, operating her business between 1927 and 1954. Born in Rome in 1890, the daughter of an orientalist scholar, she first left Italy in 1913. She traveled via Paris to London, where she married a theosophist named Wilhelm Went de Kerlor in 1914. During World War I, she and her husband moved in artistic and cosmopolitan circles between Europe and the United States. When Schiaparelli separated from her husband in the early 1920s, she returned to Paris with her young daughter. There she came to know Paul Poiret, who often loaned the impoverished young woman dresses to wear.

#### Early Career

With Poiret's encouragement, Schiaparelli began to design clothes and sell her designs on a freelance basis to small fashion houses. She briefly became the designer of a small house, Maison Lambal, in 1925 before setting up an atelier in her own name in 1927. Schiaparelli's first collection featured hand-knitted trompe l'oeil sweaters, including an extremely successful black-and-white "bow-knot" sweater that was illustrated in *Vogue* and immediately sold in the United States. Her subsequent collections extended beyond sweaters to include dresses and suits, swimsuits and beach pyjamas, ski costumes and sports jackets. In the early 1930s her "Mad Cap," a simple knitted hat with distinctive pointed ends that could be pulled into any shape, was a runaway success in the United States, where, like the "bow-know" sweater, it was widely copied by mass-market manufacturers. In 1928 she launched her first perfume, S.

In the late 1920s and early 1930s Schiaparelli was primarily a designer of sportswear whose geometric patterns and sleek lines were in keeping with the mood of the moment. Yet these early collections contained many hallmarks of her styles of the later 1930s: the innovative use of fabrics, often synthetic; striking color contrasts; such unusual fastenings as zippers; and such eccentric or amusing costume jewelry as a white porcelain "Aspirin" necklace designed by the writer Elsa Triolet.

Schiaparelli's designs proved popular with Parisians and New Yorkers alike. Despite the 1929 economic crash, which significantly depleted the fortunes of French haute couture, Schiaparelli was still able to work successfully with American manufacturers in the early 1930s, and to sell her models to exclusive importers like William H. Davidow and such stores as Saks Fifth Avenue in New York. Later she was to remark that the more outrageous her designs became, the better they sold to a conservative clientele. Despite Schiaparelli's reputation as an artistic designer, she was always commercially successful.

Throughout the 1930s the fashionable silhouette changed; from the early 1930s Schiaparelli developed the boxy padded shoulders that were to characterize her mature style. Notable designs from 1934 included a "tree-bark" dress—actually crinkled rayon—and a "glass" evening cape made from a new synthetic material called Rhodophane. Schiaparelli benefited from significant developments in textiles in the 1930s, but she was never purely technologically driven. Rather, her work was galvanized by the themes of masquerade, artifice, and play—themes that related closely to the changing status of women in the interwar years, as well as to the avant-garde discourse of the surrealist artists and their circles, some of whom she worked with in the 1930s.

#### The Later 1930s

Schiaparelli moved her boutique to the Place Vendôme in 1935, commissioning Jean-Michel Franck to decorate





**Elsa Schiaparelli.** One of the top designers of the 1920s through the 1940s, Elsa Schiaparelli is known for both her playful and elaborate fashions and her success in the marketplace. AP/WIDE WORLD PHOTOS. REPRODUCED BY PERMISSION.

her new premises. Their ever-changing décor incorporated, at various times, a stuffed bear that the artist Salvador Dalí had dyed shocking pink and fitted with drawers in its stomach, a life-size dummy of Mae West, and a gilded bamboo birdcage for the perfume boutique. In 1935 Schiaparelli inaugurated themed collections, starting with Stop, Look and Listen for summer 1935. “Schiaparelli collection enough to cause crisis in vocabulary,” read a contemporary review of Stop, Look and Listen (Schiaparelli, p. 87). Following the Music Collection of 1937, Schiaparelli surpassed herself in 1938 and showed four collections in a single year: the Circus Collection for summer 1938, the Pagan Collection for autumn 1938, the Zodiac or Lucky Stars Collection for winter 1938–1939, and the Commedia dell’Arte Collection or A Modern Comedy for spring 1939. Her presentations were more like shows or plays than the conventional mannequin parade. Incorporating stunts, tricks, jokes, music, and light effects, they were dramatic

and lively, and entry to them was as much sought after as tickets to a new play.

In 1937 Schiaparelli launched the color of vivid pink that she named “shocking,” alongside her perfume Shocking!, packaged in a bottle designed by the artist Leonor Fini and based on the shape of Mae West’s torso. The same year saw the designer’s Shoe Hat ensemble, a black suit with pockets embroidered with lips and an inverted high-heeled shoe for a hat. The hat came in two versions, one that was all black, and the other, black with a shocking pink heel. The 1938 Circus collection featured a black evening dress with a padded skeleton stitched on it, boleros heavily embroidered with circus themes, and an inkwell-shaped hat whose feather resembled a quill pen. The 1938 Zodiac collection featured more highly encrusted embroidery such as the mirror suit, in which inverted baroque mirrors were embroidered on the front panels of the jacket and incorporated pieces of real mirrored glass. Schiaparelli encouraged the embroidery firm Maison Lesage to revive techniques from both medieval ecclesiastical vestments and eighteenth-century military uniforms. The result was a series of highly wrought evening jackets and accessories in which the decoration of the garment became a carapace or form of female armor.

While Schiaparelli was clearly established commercially as a fashion designer, she also retained many links, both personal and professional, with surrealist artists. In New York during World War I she knew Francis Picabia and his then wife Gabrielle, who introduced her to the artistic photographer Man Ray and the painter/sculptor Marcel Duchamp. Schiaparelli was photographed by Man Ray in the early 1920s and then again in 1930. Man Ray regularly took photographs for fashion magazines, including *Vogue* and *Harper’s Bazaar*; some of these photographs also appeared in the surrealist magazine *Minotaure*, which was published between 1933 and 1939. An essay of 1933 by the surrealist writer Tristan Tzara was illustrated by Man Ray’s photographs of Schiaparelli’s hats. She in turn employed many surrealist artists to design accessories for her. The writer Elsa Triolet made jewelry for Schiaparelli and other couturiers, with her husband Louis Aragon acting as the salesman. Alberto Giacometti made brooches for Schiaparelli, while Meret Oppenheim produced fur-lined metal bracelets. Christian Bérard illustrated Schiaparelli’s designs and many of the program covers for her openings or fashion shows. In 1937 the designer used drawings done for her by the artist Jean Cocteau as trompe l’oeil embroidery on two evening garments, a blue silk coat and a grey linen jacket.

Schiaparelli’s collaboration with Salvador Dalí, however, which began in 1936, produced a series of the most striking designs: chest of drawer suits (with horizontal pockets that looked like drawers and buttons that resembled drawer handles) from 1936, an evening dress with lobster print and a shoe hat and suit from 1937, and an evening dress with a tear design from 1938.

Apart from these accredited collaborations Schiaparelli produced many surrealist designs of her own from the start of her career, some clearly in homage to her contemporaries, others apparently her own inspiration: black suede gloves appliquéd with red snakeskin fingernails inspired by Man Ray; a telephone-shaped handbag inspired by Dalí and a brain-shaped hat made of corrugated pink velvet; buttons in the shape of peanuts, padlocks, and paper clips; multicolored wigs coordinated with gowns; and the first fabric designed to mimic newsprint, printed with Schiaparelli's own reviews in several languages. Meanwhile, Schiaparelli maintained her contacts with fashion-related industries in both the United States and Britain, collaborating with textile and accessory designers on specific ranges as well as selling model gowns through exclusive importers. She also worked in both theater and the cinema as a costume designer, most notably dressing Mae West for the film *Every Day's a Holiday* (1937).

Throughout the 1930s Schiaparelli continued to travel, many times to the United States, and once in 1935 to a trade fair in the Soviet Union. Although based in Paris, she had opened a branch of her salon in London in 1933. Schiaparelli's international clientele included Lady Mendl, Wallis Simpson, and various titled Englishwomen; she frequently designed costumes for such elaborate costume balls of the decade as the honorable Mrs. Reginald Fellowes's Oriental Ball in 1935 and Lady Mendl's Circus Ball of 1938. The chic and distinctive Daisy Fellowes was Schiaparelli's unofficial mannequin; the designer dressed her for free and she in turn attracted international publicity in newspapers and magazines as one of the few women who wore Schiaparelli's more outré designs. If Daisy Fellowes personified the Schiaparelli look, the American Bettina Bergery, née Jones, personified the designer's spirit. Equally elegant and rakish in her own person, Bergery was the editor of French *Vogue* between 1935 and 1940 as well as Schiaparelli's assistant, responsible in the late 1930s for the witty and iconoclastic window displays in Schiaparelli's salon on the Place Vendôme.

### The 1940s and 1950s

Schiaparelli, who had taken French citizenship in 1931, set out on an American lecture tour after the Germans occupied Paris in 1940. She chose to return to the occupied city in January 1941, but within a short period was forced to leave again for New York, where she spent the remainder of the war. Schiaparelli's Paris house remained open throughout the war and produced collections, although they were not designed by Schiaparelli herself. Her early wartime designs, made before she departed for the United States, often used military themes but in a playful way, such as a one-piece "air-raid shelter" trouser suit. She also pioneered many innovative pocket designs in her Cash and Carry collection for spring 1940. She returned to Paris immediately after the end of the occupation in 1945 and resumed designing, picking up where

she had left off in 1940, but focusing more on unusual cuttings and draping. Schiaparelli's designs from this period included a hat like a bird's nest with nesting birds; illusion bustle dresses; and inverted necklines that rose to cover the cleavage but dipped to reveal the breasts.

Throughout the late 1940s and early 1950s Schiaparelli continued to make merchandising and licensing deals with several American companies, but in terms of innovative design Cristóbal Balenciaga and Christian Dior took the lead in the 1950s. Dior's New Look of 1947 ushered in a new era in fashion. Schiaparelli's fortunes declined gradually after that; in 1954, the same year that Coco Chanel returned to Paris couture, Schiaparelli's Paris salon filed for bankruptcy. Thereafter the designer spent much of her time in Tunisia, where she had bought a house in 1950. Her autobiography, *Shocking Life*, was published in 1954. Schiaparelli died in Paris in 1973 at the age of 83, survived by her daughter Gogo and her granddaughters, the actresses Marisa Berenson and Berinthia ("Berry") Berenson Perkins.

Schiaparelli's fashion legacy was a vast body of endlessly inventive and original designs. She made elaborate visual jokes in garments that layered images deceptively on the body, to explore the themes of illusion, artifice, and masquerade. One of her couture clients, Nadia Georges Port, recalled: "For us 'Schiap' was much more than a matter of mere dresses: through clothes she expressed a defiance of aesthetic conventions in a period when couture was in danger of losing itself in anemic subtleties" (*Musée de la mode*, p. 125). Less well known, however, is the fact that, despite her apparently avante garde designs, she always maintained successful business relationships with American middle market manufacturers. In this respect she is a paradigm of the modern designer, marrying a fertile imagination and dramatic showmanship to a pragmatic and commercial base.

See also **Art and Fashion; Cardin, Pierre; Fashion Designer; Givenchy, Hubert de; Paris Fashion; Poiret, Paul; Vogue; Windsor, Duke and Duchess of.**

### BIBLIOGRAPHY

- Ballard, Bettina. *In My Fashion*. New York: David McKay and Co., Inc., 1960.
- Blum, Dilys E. *Shocking! The Art and Fashion of Elsa Schiaparelli*. Philadelphia, New Haven, Conn., and London: Philadelphia Museum of Art in association with Yale University Press, 2003.
- Evans, Caroline. "Masks, Mirrors and Mannequins: Elsa Schiaparelli and the Decentered Subject." *Fashion Theory* 3 (1999): 3–32.
- Musée de la mode et du costume, Palais Galliera. *Hommage à Elsa Schiaparelli: exposition organisée au Pavillon des arts... Paris, 21 juin–30 août 1984*. Paris: Ville de Paris, Musée de la mode et du costume, 1984.
- Schiaparelli, Elsa. *Shocking Life*. New York: E. P. Dutton and Co., 1954.

White, Palmer. *Elsa Schiaparelli: Empress of Paris Fashion*. London: Aurum Press, 1986.

———. *Haute Couture Embroidery: The Art of Lesage*. Paris: Vendôme Press, 1988; and Berkeley, Calif.: Lapis Publications, 1994.

Caroline Evans

**SCOTCHGUARD.** *See* Performance Finishes.

**SCOTTISH DRESS** The most renowned form of Scottish dress is Highland dress, which is internationally recognized as a symbol of Scottish identity. The predominant feature of the Scottish contribution to western fashionable dress is that of distinctive fashion textiles that have international appeal once made up into garments.

### Highland Dress

Highland dress has been worn, interpreted, and mythologized in many different ways and its history is therefore fascinating and complex. From the early nineteenth century, Highland dress began to be seen as synonymous with Scotland as a whole. However, its origins relate to the specific culture that existed in the northerly Highland region of Scotland up until the late eighteenth century. Dress in the Highlands was initially closely linked to Irish Gaelic culture, consequently men's dress included long "saffron" shirts, trews (leg-coverings between trousers and stockings), and brown or multicolored mantles (a type of simple-shaped cloak). By 1600 men's dress had evolved to fit the following description:

the habite of the Highland men ... is stockings (which they call short hose) made of a warm stuff of divers colours, which they call tartane...a jerkin of the same stuff that their hose is of ... with a plaid about their shoulders, which is a mantle of divers colours (Cheape: 15).

The plaid or *breacan* was worn by all sections of Highland society and by both genders. It was a versatile garment, comprising an untailed piece of cloth, usually tartan, that was draped around the body in various ways. Men commonly wore it as the *breacan an fheilidh* or belted plaid, where it was gathered in folds around the waist to form a short-skirted shape, and the remainder was draped over the shoulder and fastened with a brooch. The belted plaid formed the basis of the tailored *feileadh beag*, in English phillabeg or little kilt, which is the form the kilt takes in the early 2000s. This adaptation was initiated by the English industrialist Thomas Rawlinson between 1727 and 1734, when he found that workmen at his Invergarry furnace needed a more practical form of dress than the unwieldy belted plaid.

The defeat of the Jacobite army at the battle of Culloden in 1745 was followed by the Disarming Acts of 1746, which involved the proscription of all forms of Highland dress until 1782. The kilt survived this period largely owing to the British establishment's adoption of Highland dress as the uniform of its Highland regiments. The militarization of Highland dress was to play an important role in shaping the visual imagery of the British Empire. It also informed the design of the fanciful version of Highland dress worn by George IV on a state visit to Edinburgh in 1822. This period also involved the creation of popular, romanticized interpretations of Scotland's history by several authors, including Sir Walter Scott. From the 1840s Queen Victoria's passion for the Highlands was to further promote the fashionability of Highland dress. Victorian interpretations of it were often outlandish; however, this period also saw the establishment of the key elements of the style as it is worn in the early twenty-first century, namely, the combination of neatly pleated kilt, decorative sporran, knee-length hose with *sgian dubh* (black knife), tweed or other short tailored jacket, and sturdy brogue shoes.





Queen Victoria promoted the fashionability of Highland dress in her instructions to Edwin Landseer concerning the painting *Royal Sports on Hill and Loch*, 1874. "It is to be thus: I, stepping out of the boat at Loch Muich, Albert in his Highland dress, assisting me out. Bertie is on the deer pony with McDonald ... standing behind, with rifles and plaids on his shoulder. In the water ... are several of the men in their kilts." (Ormond, pp. 159–160)

### Scottish Textiles as Fashion Garments

Tweed was transformed from a locally crafted product into a fashion textile sold to international markets by Scottish woolen manufacturers of the 1820s. Since that time tweed has played an important role in defining various clothing styles, from the Chanel suit, to men's sports jackets of the 1950s. The prominent Scottish tweed manufacturer J. & J. Crombie of Grandholm, founded in 1805, soon became renowned for their quality Elysian overcoatings, which subsequently led to the development of the Crombie coat style.

The distinctive design of the Paisley shawl originated in India in the fifteenth century. However, the garment derives its name from a town on the west coast of Scotland, which from about 1805 to the 1870s built a highly successful trade on the weaving of Paisley shawls.

### Knitwear

Scottish knitwear patterns and yarns, derived from remote rural communities such as Fair Isle and Shetland, are well known internationally. In addition, companies such as Pringle, Johnstons of Elgin, and Ballantynes Cashmere, who sell to the international luxury knitwear market, design and make their products in Scotland. In the 1930s a designer who worked for Pringle, Otto Weisz, introduced the twinset style, which became hugely popular with Hollywood starlets and the wider market.

### Scotland and the Fashion Industry

Scottish clothing manufacturers, designers, and retailers tend to be of international significance only when they are linked to the knitwear or textile industry. Notable exceptions to this include the retailer John Stephen, who initiated the Carnaby Street boutique phenomenon of the 1960s, and the designers Bill Gibb, Alastair Blair, Pam Hogg, and Jean Muir. In the twenty-first century anonymous Scottish-based knitwear and textile designers continue to make an important contribution to international fashion, supplying international brands such as Prada, Dolce & Gabbana, and Ralph Lauren. Many twentieth-century fashion designers have referenced Scottish dress

in some form in their collections. However, it is notable that it tends to be the more iconoclastic designers such as Vivienne Westwood, Jean-Paul Gaultier, John Galiano, and Alexander McQueen who repeatedly return to the use of either distinctively Scottish textiles, or the paraphernalia of Highland dress in their work. This demonstrates that despite the capacity of Highland dress and Scottish fashion textiles to encapsulate "authentic" reassuring connotations of history, they have also been endlessly reinvented to suit the changing character of fashion and popular notions of Scottish identity.

See also **Kilt; Paisley; Plaid; Shawls; Tartan; Tweed; Uniforms, Military.**

### BIBLIOGRAPHY

- Allan, John. *Crombies of Grandholm and Cothal 1805–1960: Records of an Aberdeenshire Enterprise*. Aberdeen: The Central Press, 1960.
- Cheape, Hugh. *Tartan the Highland Habit*. Edinburgh: National Museums of Scotland, 1995.
- Dunbar, John Telfer. *The Costume of Scotland*. London: B.T. Batsford, Ltd., 1981.
- Gulvin, Clifford. *The Tweedmakers: A History of the Scottish Fancy Woollen Industry 1600–1914*. New York: Newton Abbott, David and Charles, 1973.
- Haye, Amy de la. *The Cutting Edge: 50 Years of British Fashion 1947–1997*. London: V & A Publications, 1996.
- Lochrie, Maureen. "The Paisley Shawl Industry." In *Scottish Textile History*. Edited by John Butt and Kenneth Ponting. Aberdeen, Scotland: Aberdeen University Press, 1987.
- Ormond, Richard. *Sir Edwin Landseer*. London: Thames and Hudson, Inc. New York: Rizzoli International, 1981.
- Trevor-Roper, Hugh. "The Invention of Tradition: The Highland Tradition of Scotland." In *The Invention of Tradition*. Edited by Eric Hobsbawm and Terence Ranger. Cambridge, U.K., and New York: Cambridge University Press, 1983.

Fiona Anderson

**SEAMSTRESSES** Seamstresses formed the main labor force, outside tailoring, which fueled the expansion of clothing production and related trades from the seventeenth century onward. This expansion was not dependent initially on technological developments or the introduction of a factory system, but on the pool of women workers. Their expendability and cheapness to their employers was effectively guaranteed by the sheer number of available women able and willing to use a needle, their general lack of alternative employment, and by the fact they then worked outside the control of guilds and latterly have been under-unionized. These seamstresses sewed goods for the increasing market for ready-made basic clothes such as shirts, breeches, waistcoats, shifts, and petticoats for working people, or slops as they were known (after the practice of sailors who stored their



**“THE SONG OF THE SHIRT”  
BY THOMAS HOOD**

With fingers weary and worn,  
With eyelids heavy and red,  
A Woman sat in unwomanly rags.  
Plying her needle and thread—  
Stitch! Stitch! Stitch!  
In poverty, hunger, and dirt,  
And still with a voice of dolorous pitch  
Would that its tone could reach the Rich! —  
She sang this ‘Song of the shirt!’

Thomas Hood, “The Song of the Shirt,” *Punch*, Christmas  
1843. (Flint, p.105)

working clothes in slop chests). Their history is largely anonymous. However, social and economic historians with an interest in gender are now extending the knowledge of seamstresses’ central role in the historical growth of clothing production and consumption.

At the cheaper end of the trade, the work of seamstresses did not involve complex cutting, fitting, or designing, though there were no hard and fast rules. “Seamstress” has always been a flexible term, with the work involved dependent on local conditions and the agency of individuals. Some elaboration and finishing was involved, such as tucking or buttonholes. While work done in this style continued, seamstresses were generally distinguished from dressmakers, milliners, mantua-makers, stay-makers, embroiderers, and tailoresses by their lower levels of craft and skill, but at the top-end of the market fine sewing was valued. Their existence was precarious and exacerbated by layoffs due to seasonal demand and unpredictable changes of fashion. In the Victorian period, widespread demand for mourning clothes, short notice given for elaborate evening dresses, and fickle customers were commonly cited as causes of distress through overwork.



“Riding an omnibus through ... [London’s commercial districts] at the turn of the century, one could hardly avoid noticing gaunt and harried women and children scurrying through the streets ... carrying heavy bundles ... passing along from workroom to workroom the shirts, suits, blouses, ties and shoes that soon would dress much of the world.” (Schmiechen, p. 1)

There were large numbers of seamstresses in a wide range of situations. They frequently worked as outworkers, on per-piece pay, in small workshops or in their homes. Having learned their trade in waged work, many seamstresses continued to use their skills after marriage by taking in work, often making simple garments or restyling old ones in their own poor communities where they played an important role in the provision of cheap clothing outside the regular retail trade. Some seamstresses were employed in a temporary but regular visiting capacity in wealthier households where they supplemented existing domestic staff and worked by arrangement through an accumulation of sewing and mending tasks, in exchange for a day rate of pay and meals. This practice lingered until World War II in some areas of Britain.

The widespread use of the sewing machine from the 1860s increased the pace of production of clothing because it could stitch up to thirty times faster than a hand sewer, but it did not immediately result in centralized factories becoming the dominant means of production. Clothing production remained characterized by many small-scale businesses, often subcontracting work, and by the subdivision of the various tasks involved in the making of a garment, using many outworkers and home workers. This drove down prices and wages and produced the sweatshop system in which many seamstresses worked very long hours for low wages. Despite well-meant attempts to reform the trade, pay and conditions remained bad throughout the nineteenth century and well into the twentieth. It was said that a practiced observer could identify a seamstress in the street because of her stooped carriage. Seamstresses in outworking were vulnerable to employers who could withhold or delay payment if work was deemed substandard. It was common practice for seamstresses in this kind of work to have to pay for their own thread, needles, and candles, in addition to their heating and costs of collecting and returning the work. “My usual time of work is from five in the morning till nine at night—winter and summer.... But when there is a press of business, I work earlier and later.... I clears about 2s 6d a week.... I know it’s so little I can’t get a rag to my back” (London shirt maker talking to Henry Mayhew in 1849, cited in Yeo, p. 145). Despite enormous disadvantages, it was seamstresses who staged the first all-female strike in America, in New York in 1825. Apprenticeship provided one means, however, unreliable and open to abuse, for women to learn the better end of the trade. Some women found that the clothing trade presented opportunities for them to trade effectively as seamstresses on their own account or to work as middle women, putting out work. Health and safety legislation, greater unionization, and factory production have combined to improve the lot of women working in the late twentieth and early twenty-first centuries in the clothing trades; nevertheless, globally, it remains a fragmented industry with widespread homework and low wages.

### Popular Debates and Imagery

Prints and paintings, often sympathetic if moralistic, frequently showed individual women bent over their sewing, in shabby interiors, sewing either to support themselves or their families. Middle-class women, fallen on hard times, were also depicted eking out a living in this way, a particular anxiety in Victorian Britain. Allegations of immorality, including prostitution, were frequently made, based on perceptions of the effects of poverty or, in better-class workrooms, the supposed temptations caused by familiarity of young seamstresses with fashion and luxury beyond their means. In Britain in 1843, Thomas Hood's poem *The Song of the Shirt* dramatized their plight and helped focus attention on potential reforms to wages and conditions, mostly without long-term effect. In 1853 Elizabeth Gaskell's novel *Ruth* expanded on the theme of exploitation of seamstresses and the suffering caused by extravagant demands of selfish or ignorant customers; the subject was treated in the United States in Charles Burdett's 1850 *The Elliott Family or the Trial of New York Seamstresses*.

See also **Sewing Machine; Sweatshops; Textile Workers.**

### BIBLIOGRAPHY

- Coffin, Judith. *The Politics of Women's Work: The Paris Garment Trades 1750–1915*. Princeton, N.J.: Princeton University Press, 1996.
- Flint, Joy. *Thomas Hood: Selected Poems*. Manchester, U.K.: Carcanet, 1992.
- Gamber, Wendy. *The Female Economy: The Millinery and Dress-making Trades, 1860–1930*. Urbana: University of Illinois Press, 1997.
- Green, Nancy. *Ready-to-Wear and Ready-to-Work: A Century of Industry and Immigrants in Paris and New York*. Durham, N.C.: Duke University Press, 1997.
- Jenson, Joan M., and Davidson, Sue, eds. *A Needle, a Bobbin, a Strike: Women Needleworkers in America*. Philadelphia: Temple University Press, 1984.
- Lemire, Beverly. *Dress, Culture and Commerce: The English Clothing Trade before the Factory, 1660–1800*. New York: St. Martin's Press, 1997.
- Schmiechen, James A. *Sweated Industries and Sweated Labour: The London Clothing Trades 1860–1914*. Urbana: University of Illinois Press, 1984.
- Stansell, Christine. *City of Women: Sex and Class in New York 1789–1860*. Urbana: University of Illinois Press, 1987.
- Stewart, Margaret, and Hunter, Leslie. *The Needle Is Threaded: The History of an Industry*. London: Heinemann/Newman Neame, 1964.
- Yeo, Eileen, and E. P. Thompson. *The Unknown Maybew*. New York: Pantheon Books, 1971.
- Walkley, Christina. *The Ghost in the Looking Glass: The Victorian Seamstress*. London: Peter Owen, 1981.

Barbara Burman

### SECONDHAND CLOTHES, ANTHROPOLOGY OF

Well into the nineteenth century, secondhand garments constituted the clothing market for much of the population in Europe and North America except the very rich. In the post–World War II economic growth era, affordable mass-produced garments, broader income distribution, and growing purchasing power reduced the need for large segments of the population to purchase used clothing, although people with small means still frequent secondhand clothing stores. Throughout the West in the early 2000s, secondhand clothing by and large makes up fringe or niche markets for the purchase of retro, vintage, or special garments, while in many developing countries, secondhand clothing imported from the West is an important clothing source.

Secondhand clothing consumption is often described as consisting of two distinct worlds: one is the world of fashion and the other the world of thrift. These divisions are then mapped onto distinctions between industrialized and the developing nations, hiding the attraction of secondhand clothes to rich and poor dress-conscious consumers alike, regardless of their location.

Charitable organizations are the largest single source of the garments that fuel the international trade in secondhand clothing. Because consumers in the West donate much more clothing than the charitable organizations can possibly sell in their thrift stores, the charitable organizations resell their massive overstock at bulk prices to secondhand clothing dealers. These dealers are the textile recyclers/graders who sort, grade, and compress used clothes into bales for export. The United States is the world's largest exporter, and Africa the largest importing region in an international trade that has grown rapidly since the late 1980s. There are several Asian and Middle Eastern countries among the large importers of secondhand clothing. Sizeable imports go not only to developing countries but also to eastern Europe and Japan. Some countries restrict or ban the commercial import of secondhand clothes in efforts to protect domestic textile and garment industries.

The charitable connection attached to secondhand clothes vanishes at the point of resale when used garments enter the wardrobes of their new wearers to begin another stage of their lives. Past and present, the trade and consumption of secondhand clothing not only enabled its participants to support livelihoods but also to experience well-being and construct identities in a changing world. In the contemporary West, this process often involves the incorporation of accessories and specific garments into distinct dress styles. Secondhand clothes got a new cachet when shoppers for vintage couturier styles began turning to upscale used clothing stores that sell garments on consignment from the rich and famous. As vintage has become fashion, buyers for Urban Outfitters stores source clothes directly from secondhand dealers, then chop them up into raw materials that are redyed,





**Secondhand suit.** A man has a secondhand suit adjusted at a tailor shop in 1998. © SIMONPETRI CHRISTIAN/CORBIS SYGMA. REPRODUCED BY PERMISSION.

reewn, and resold as new garments. Buying secondhand clothes is an important choice for the young and trendy.

In twenty-first-century Germany, the 1960s style scene of movies, music, and material culture is popular with young people who dress in garments from the 1960s or in self-made clothes constructed from old patterns. This retro style attributes history and authenticity to garments that wearers experience as unique and personal.

Dress practices arising around the consumption of imported secondhand clothing in developing countries have frequently been noted in passing only to be dismissed offhandedly as faded and poor imitations of the West's fashions. Many economists would be inclined to view the growth of the secondhand clothing market in developing countries as a response to economic decline. Such accounts miss the opportunities this vast import offers consumers to construe themselves through dress.

In Zambia, a country in the southern part of Africa, consumers from all income levels turned eagerly to the secondhand clothing markets when import restrictions were lifted in the 1980s. Shipped for export by dealers in North America and Europe, containers loaded with bales of secondhand clothes arrive at ports in South Africa,

Mozambique, and Tanzania, reaching the warehouses of wholesalers in Zambia by truck. The market soon reached remote villages, enabling residents not only to clothe their bodies but also to present themselves with style. The attraction of secondhand clothes to dress-conscious Zambians goes far beyond the price factor and the good quality for the money that many of these garments offer. Finding the uniqueness they miss in much store-bought clothing, consumers turn to secondhand clothing markets for garments that are not common. The abundance and variety of secondhand clothing allows consumers to make their individual mark on the culturally accepted dress profile. Far from emulating the West's fashions, secondhand clothing practices implicate clothing-conscious consumers in efforts to change their lives for the better.

In Ifugao, the translocal trade circulates through channels rooted in local cultural scripts, guided by notions of personalized associations that women traders use in their business activities. In narratives about secondhand clothing, retailers, vendors, and consumers draw connections between people and clothes that constantly change. Such tales domesticate the logic of the market and the meaning of this global commodity in terms of

local norms of status and values and in the process, they transform them. Combining secondhand garments into styles that display knowledge of wider clothing practice or subvert its received meanings, traders and consumers create new meanings around this imported commodity to serve their personal and community identities.

While India prohibits the import of secondhand clothing, it does permit the import of woolen fibers, among which are “mutilated hosiery,” a trade term for wool garments shredded by machines in the West prior to export. These imported “mutilated” fabrics are sorted into color ranges, shredded, carded, and spun before they reappear as thread used for blankets, knitting yarn, and wool fabrics for local consumption and export. India also has a large domestic secondhand clothing market that is a product of shifts in wardrobes, dress changes over the course of a person’s life cycle, and hand-me-downs to servants and relatives. This process gives rise to considerable domestic recycling of Indian clothing by barter, donations, and resale. Here, the materiality of cloth itself serves as a strategic resource for the unmaking and remaking of persons and identities.

*See also* **Recycled Textiles; Secondhand Clothes, History of; Vintage Fashion.**

#### BIBLIOGRAPHY

- Hansen, Karen Tranberg. *Salaula: The World of Secondhand Clothing and Zambia*. Chicago: University of Chicago Press, 2000.
- Jenss, Heike. “Sixties Dress Only! The Consumption of the Past in a Youth-cultural Retro-Scene.” In *Old Clothes, New Looks: Second-Hand Fashion*. Edited by Alexandra Palmer and Hazel Clark. Oxford: Berg, 2004.
- Milgram, Lynne B. “‘Ukay-Ykay’ Chic: Tales of Fashion and Trade in Secondhand Clothing in the Philippine Cordillera.” In *Old Clothes, New Looks: Second-Hand Fashion*. Edited by Alexandra Palmer and Hazel Clark. Oxford, U.K.: Berg, 2004.
- Norris, Lucy. “The Life Cycle of Clothing in Contemporary Urban India (Delhi).” In *Old Clothes, New Looks: Second-Hand Fashion*. Edited by Alexandra Palmer and Hazel Clark. Oxford, U.K.: Berg, 2004.

*Karen Tranberg Hansen*

## SECONDHAND CLOTHES, HISTORY OF

The reappropriation of pre-worn clothes and accessories, historically reviewed, includes a range of practices, from straightforward methods of unhemming garments and reusing the raw material, perhaps turning it to the less worn side, as would have been practiced in medieval times, to the complex scaffold of trades in the nineteenth century. These industries recycled all manner of clothing, with machine-like economy, through specialist and discreet skills. Perhaps the most technologically advanced

was the production of “shoddy” cloth in the North of England from rags of wool, cotton, and indeed all fibers (except silk) which became the staple fabric for the ready-to-wear garment production in 1834.

An exploration of the formal and informal ways by which secondhand clothes reached the resale market should highlight that some apparently informal ways may indeed be considered formal, especially in the case of servants receiving their masters’ “gifts” of clothing, which were actually considered a part of their remuneration.

In fact, the secondhand clothing trade could be said to have actually diminished in complexity over the last two centuries. It used to consist of many separate businesses employing various skills necessary for the economical recycling and remarketing of different categories of actual garments, as well as the raw material of cloth.

But the origins of the advanced complexity of the secondhand clothing industries of the nineteenth century can be discerned much earlier in records of the extensive exchanges of secondhand garments amongst the Western world’s urban populations during the latter half of the seventeenth century.

### A Seventeenth Century Londoner’s Wardrobe

The Londoner Samuel Pepys’ diary (1660–1669) tells of many transactions involving clothing, and perhaps many more where such gifts are offered and accepted. Scholars of the diary often note intimations of Pepys’ vanity: he did indeed regularly employ his father’s tailoring skills to restyle old garments, often to reflect London’s fluctuating fashions. Thus many gifts from the wardrobes of Pepys’ more affluent friends were adapted to better suit the needs of their new master. “Samuel Pepys, though vain, was not too proud to sport a second-hand accessory of quality which he could not afford to buy himself” (Stanlisland, p. 5).

At this time London’s secondhand tradesmen were dealing in very large amounts of stock, both old clothing and new, in some cases bringing in thousands of pounds. Such traders were very profitably engaged in the provision of ready-made clothing for the seamen living and working aboard sailing fleets for months at a time, for which the clothes’ dealers would be paid thousands of pounds in each transaction. The seventeenth-century Venetian experience contrasts with that of London in that the framework by which tradesmen were permitted to go about their business was strictly governed by regulatory bodies. For instance, the Venetian Guild of secondhand clothes dealers, *L’Arte degli Strazzaruoli*, in tandem with various civic bodies, including Venetian health officials, conspired to regulate every aspect of the trade, particularly during plague outbreaks as used cloth exchanges were suspected of transmitting disease. A particularly interesting feature of the Venetian trade is its close association with prostitution; Venetian courtesans procured clothing, by buying or renting, from such secondhand sources.



**Secondhand clothes stand.** Customers browse the offerings at a secondhand clothing stand in Liverpool, England, 1957. © HULTON-DEUTSCH COLLECTION/CORBIS. REPRODUCED BY PERMISSION.

### The Eighteenth, Nineteenth, and Twentieth Centuries

During the eighteenth century, London's secondhand clothes industry was closely allied with its "slop" or ready-made clothing trade. Madeleine Ginsburg, a leading scholar in this field, identifies a considerable disparity between the provincial availability of used clothing in comparison to urban areas at this time. It is an equally important point that secondhand clothing not only furnished the affluent with more or less fashionable clothing, it was also an essential source of basic clothing provision for the poor. Focusing specifically on the Scottish city of Edinburgh, Elizabeth C. Sanderson has evaluated the role of the trade as a central part of the everyday life of most citizens. She makes the important point that during the eighteenth century the use of pre-worn clothing was an experience familiar to nearly all classes in society.

Considered perhaps the definitive account of the mid-nineteenth century increase in the trade, H. Mayhew's *London Labour and London's Poor* tells of the concentration of activity in London's East End. However,

the most consequential development at this time was the increasingly competitive pricing of cotton and wool fabrics, and accordingly, ready-to-wear garments, thus exponentially limiting the appeal of secondhand clothing, in home markets at least. In this way, used clothing exports, especially to Africa, became an ever more significant aspect of the trade. This is an angle explored particularly thoroughly by Karen Tranberg Hansen's research into Zambia's trade, whereas Ginsburg interprets charity, and the rise of the rummage sale, as the most important developments taking the industry into the twentieth century. Certainly the retail environment constituted by such sales, where purchasers rummage through large quantities of stock, could be considered conducive to the quick and efficient sale of used goods, particularly in urban areas.

World Wars I and II saw the increase of the profitable potential of secondhand clothing, especially for resale in Africa. At this time the supply and demand aspect could be strongly linked to the West's veritable accumulation of serviceable and wearable, but outmoded, clothing and the real needs for clothing in developing countries.





“Having my old black suit new-furbished, I was pretty neat in clothes today—and my boy [footboy], his old suit new-trimmed very handsome” (Stanisland, p. 46).

And it is here that one may perceive the beginnings of the nature that characterizes the trade in the early 2000s.

### Interpreting Contemporary Trends

From the 1970s onward, fashion commentators have often noted a marked plurality of styles, compared to the former singularity of fashion houses' diktats; a development engendering fertile environments for alternative, niche fashions, and retrogressive styling. Thus second-hand clothing has come to be seen as offering potential for expressing individual and more autonomous style.

The early 2000s have seen widespread fashion trends reflecting early twentieth-century styles and the decades after World War II. In such a fashion zeitgeist, the cultural and economic capital of secondhand clothing, or vintage as it is latterly termed, has vastly increased. Secondhand clothes' stylistic appreciation has created new markets for its retail: for instance, in designated concessions of urban fashion multiples, within the high-fashion collections of designers including Martin Margiela, and on auction websites, such as Ebay.

The international recirculation of used clothing is not as straightforward as simply the export from richer to poorer nations: specific markets present more demand for particular items, for example Japan imports a considerable percentage of the world's trade in used designer denim jeans and sneakers. In these ways the state of the secondhand clothes trade could be understood as diversifying in economic potential and enjoying a favorable shift in its industrial, public, and cultural profiles.

See also **Recycled Textiles; Secondhand Clothes, Anthropology of; Vintage Fashion.**

### BIBLIOGRAPHY

- Allerston, Patricia. “Reconstructing the Second-Hand Clothes Trade in Sixteenth and Seventeenth Century Venice.” *Costume* 33 (1999): 46–56.
- Arnold, Rebecca. *Fashion, Desire and Anxiety*. I. B. Tauris and Co., 2001.
- Ginsburg, Madeleine. “Rags to Riches: The Second-Hand Clothes Trade 1700–1978.” *Costume* 14 (1980): 121–135. Often-quoted and very thorough.
- Sanderson, C. Elizabeth. “Nearly New: The Second-Hand Clothing Trade in Eighteenth-Century Edinburgh.” *Costume* 31 (1997): 38–48.
- Stanisland, Kay. “Samuel Pepys and His Wardrobe” *Costume* 37 (1997): 41–50.

Transberg, Karen Hansen. “Other People's Clothes? The International Second-hand Clothing Trade and Dress Practices in Zambia.” *Fashion Theory* 4, no. 3 (2000): 245–274. Excellent overview of international trade.

Lynda Fitzwater

**SEQUINS.** See **Spangles.**

**SERGE.** See **Denim.**

**SEVENTH AVENUE** When a famed street is both conceptual and geographic, as Seventh Avenue in New York City is, commenting on it becomes many-pronged. To David Wolfe, the creative director of the Doneger Group, a major buying office, Seventh Avenue is a state of the mind, the creative epicenter of American fashion. He believes that where it once was a vital apparel and distribution center, it now functions as a showcase for designers and manufacturers. To Wolfe, “It is more than a street or a neighborhood, it is the geographic symbol of the power of American style.”

In the 1930s, the Garment Center, as this area was called—between 6th and 9th Avenues from 30th to 42nd Streets—was the city's largest industry, and the fourth largest in the country. Three-quarters of ready-made coats and dresses, and four out of five fur coats worn by American women, were made here.

Surprisingly, over the years, not that many books have been written about Seventh Avenue, the reality, but one author (and manufacturer) who tackled it was Murray Sices, who in 1953, could still write in his tome, not surprisingly, called *Seventh Avenue*, “Seventh Avenue in the city of New York, between 35th and 40th Street, is not merely a geographic location. It's a legend. It's the birthplace of miracles. It's the fast-beating heart of an industry whose bloodstreams course through America. ... Here with almost 4,000 firms crowded into a few square blocks, you have a concentration of apparel manufacturers such as the world has never seen elsewhere.”

That was then, this is now, and there have been many changes, most of them disastrous for Seventh Avenue and its environs. In 2000 alone, citywide garment-making jobs fell to 60,700 down from 70,100 in 1998. There were 3,260 apparel-making shops in 2000 as opposed to 3,591 in 1999, according to *Crain's New York Business Magazine*. The publication reported in 2001, “Voluntarily or not, garment workers in New York are mobbing the exits.” Industry watchers were shocked at what was happening, especially those who thought the employment drop had bottomed out in the late 1990s. Historically, however, there has been a loss of manufacturing jobs going back more than thirty years. Gone are many wholesalers and textile companies as well as companies that supplied everything. Garment manufacturing has dropped along with everything else,

from buttons to zippers and other necessities for a complete garment; even jobbers have disappeared and positions in showrooms also have evaporated.

Also there is the major question of rents that have reportedly increased in double or triple digits. Cheap imports, too, have become major culprits in the changing face of Seventh Avenue.

On the slightly brighter side, even though manufacturing of apparel is down from the 300,000 workers at its peak in the 1950s, clothing accounts for about one-fourth of the manufacturing jobs in the city, and it's still a most important entry into the business world for immigrants from everywhere. Seventh Avenue and its surrounding businesses probably will endure, because designers, even in the age of the computer, will still need workers nearby to whip up small runs of high-end clothing.

However, that segment of the business is also no longer so significant. At a time when conglomerates have swallowed up many of the major department stores, and specialty stores and discounters swamp shopping malls, the ability to ship quickly is no longer so vital. Bud Konheim, the head of Nicole Miller Inc., one of Seventh Avenue's stalwarts, still refers to himself as a "quick turnaround guy," and retains his belief in "Made in the U.S.A." through thick and thin.

In the early 2000s, *Crain's* reported that the New York Industrial Retention Network would release a study showing 60 percent of apparel leases in the garment district will expire momentarily, putting the entire local industry in a negative position.

Even though everything is changing, there is still plenty of excitement just walking Seventh Avenue and the adjacent Broadway buildings like 1410 Broadway or 550 Seventh Avenue. Models still run to do a day's work at a manufacturer's showroom during New York Fashion Week. The Tower of Babel voices from different cultures still are part of street life and lore. There are still plenty of small cafés doing takeout, or one can sit and have bagels or more exotic fare served fast and furiously.

Plenty of New Yorkers, including the mayor and other politicians, want to keep Seventh Avenue and its environs as vital as they have ever been. In 1993 the Fashion Center Business Improvement Center was inaugurated, its mission to promote garment manufacturing, but ten years later BID's concept had changed. The idea is to perhaps create for the district (running roughly from Fifth to Ninth Avenues and West 35th to 41st streets) a 24-hour seven-day-a-week place with diverse and residential units, including a fashion museum and more retail stores. BID's design center will add to the neighborhood's continuing unique personality, and allow it to remain, if not strictly a garment manufacturing area, a fashion district.

Gerald Scupp, the deputy director of the Fashion Center (which has its street of famous designers, called the Fashion Walk of Fame, similar to Grauman's Chi-

nese Theatre in Hollywood which has its famous actors' hand- and footprints) notes many initiatives have failed, but he believes, and the report suggests, that abolishing special zoning that restricts non-manufacturing uses and keeps rents low for manufacturers could work. There will be those who will object, however.

Rent alone does not explain the declining job numbers, nor do cheap imports, for some manufacturers have defected to cheaper spaces in Brooklyn and Queens, but even this has not been entirely satisfactory. Another factor is the sub rosa conversion to office space with city officials looking the other way, rather than upholding the special district concept, according to Adam Friedman, the network's executive director. He notes the city stopped inspections in 1993.

Also taking a toll on legitimate design houses in New York City are manufacturers who violate the law by not paying overtime or taxes, so many of their workers do not show up on official job statistics. If all workers were truly accounted for, the number of city garment workers might double, according to Louis Vanegas, district director of the Wage and Hour Division of the U.S. Department of Labor. But even Vanegas agrees the uncounted jobs are declining and don't really account for the precipitous drop in manufacturing.

So, what will happen to Seventh Avenue and its environs if jobs decline at historic rates? According to the BID report in the early 2000s, only about 17,000 of the city's 50,000 apparel manufacturing positions will be around by 2010. However, as of early 2004, fashion-related businesses still make up the majority of the district—64 percent or 4,245—but more of these are showrooms or mixed uses. Other tenants range from printers, ad agencies, theaters, and an unknown number of illegal residential tenants who are tucked away in lofts and other spaces. Actually, the area is becoming more residential legally, and BID supports the idea. Many property owners would love to see zoning laws changed.

That the problems of Seventh Avenue remain is borne out by a *Woman's Wear Daily* article on June 10, 2003 headed "U.S. Makers Fading Away." The piece, by Scott Malone, notes, "The withering of the nation's production base has gotten to the point where even the makers of high-end apparel, who typically were able to digest the higher costs of domestic production because of their higher prices, have begun to break into camps on the question of whether making clothing in the U.S. will remain a viable strategy for the years to come."

The article maintains that the same economic pressures that pushed most mainstream apparel manufacturing out of the country are taking hold in the top-drawer designer market. "Eventually all that will be left in this country will be a small clique of sample makers."

But all is not lost for the Seventh Avenue of the early twenty-first century. The article makes clear there is still a shrinking group of high-end designers whose dresses

carry three or even four-figure price tags who contend that domestic manufacturing in New York continues to make sense. These businessmen argue that being close to their factories allows a higher level of quality control and a faster rate of turnaround than is available overseas. Bud Konheim, “the quick turnaround guy” of Nicole Miller says, “The advantage of being domestic has nothing to do with cost.” What keeps half of his company’s manufacturing here are garment-district contractors. Konheim says, “You can get cheaper prices by going offshore, but then you’ve got a longer lead time; you have to make your decisions earlier, and you have to cut bigger quantities, so you have a lack of control. And, lack of control, in this marketplace, is very dangerous because some orders you take are not real orders. You have people canceling.” He adds that domestic manufacturing is viable only if a brand’s fashions are sufficiently distinctive so that retailers can’t get a similar product elsewhere.

Another major manufacturer, who is also a highly prized designer, Oscar de la Renta, whose firm has long been on Seventh Avenue, still makes the majority of his line in the United States. For him also, quality concerns are a key reason for staying here. The firm’s mixture of local and foreign sourcing has not changed since the early 1990s.

Famed handbag and accessories firm Judith Leiber continues to manufacture on West 33rd Street because so many of its workers have been with the company for a long time and their talents are specialized.

However, one of the problems of the apparel industry decline is that so many of the businesses that supported companies like trim suppliers or firms that stocked replacement parts died because of lack of customers. Konheim said his company has to contract many operations overseas including beading, embroidering, and hand knitting, because it no longer can find domestic companies doing that work. Ironically, at a time when going global has caused so many problems for unique Seventh Avenue and its environs, the cachet of a “Made in the U.S.A.” label remains high in Asian markets as well as in the United States and throughout the world, so there is hope.

Nowhere where apparel and its appurtenances are created is there the excitement that was and is Seventh Avenue with its polyglot charisma, its smells and street noises, its buying and selling, its rushing and stopping, its garment racks flying down the street in competent hands. Clothing is manufactured around the world, but no one has a Seventh Avenue except New York, New York.

See also **Fashion Designer; Garments, International Trade in; Leiber, Judith; Ready-to-Wear.**

#### BIBLIOGRAPHY

- Curan, Catherine. “More Fashionable Garment Area Plan.” *Crain’s New York Business* (10 March 2003).  
 Fredrickson, Tom. “Garment Area Jobs Stripped.” *Crain’s New York Business* (26 March 2001).

Malone, Scott. “U.S. Makers Fading Away.” *Women’s Wear Daily* (10 June 2003): 10.

Sices, Murray. *Seventh Avenue*. New York: Fairchild Publications, 1953. Outdated, but provides interesting earlier background information on Seventh Avenue.

*Margot Siegel*

**SEWING MACHINE** Just as the needle marked the beginning of humanity’s first technological and aesthetic efflorescence, the sewing machine affected not just tailoring and dressmaking but manufacturing technology, intellectual property management, marketing, advertising, consumer finance, world commerce, and technological leadership. Even more fundamentally, and largely unexpectedly, the sewing machine became a new kind of product—it was both commercial and domestic, and, in appearance, both industrial and ornamental. The continuing development of machine sewing is in part the story of the changing balance between household and factory.

Like the personal computer over 125 years later, early commercially successful sewing machines combined a number of separate innovations into a new system for which an immense latent demand existed. In fact, the crucial single innovation, made by Elias Howe Jr. in his patent of 1846, was a system based on a radically new curved, grooved needle with an eye at the point end. Instead of making an easily unraveled chain stitch that emulated manual work, it engaged thread from the needle with another in a moving shuttle to create a stronger lock stitch. It was the first machine with a significant advantage in speed over hand sewing, but was limited to straight stitching and could complete only a limited length of material at a time. Another inventor, John Bachelder, remedied the Howe machine’s drawbacks with an improved design patented in 1849, allowing continuous sewing of material with a needle moving up and down on a horizontal table. Isaac Merritt Singer made a series of other improvements in 1850 and 1851, making curved stitching possible and replacing the hand wheel with a treadle.

While no single inventor controlled all the patents needed to make commercially successful equipment, Singer and the others were able to settle the claims of Howe and to include his original patent in a pool. For a substantial fixed fee per machine, partly distributed by the corporation to its patent holders, any manufacturer could produce sewing machines without infringement.

The American setting was essential for the sewing machine’s success in the 1850s. A French tailor, Barthélemy Thimonnier, had secured French government support in the 1830s for establishment of a firm using his wooden-framed sewing machines to produce military uniforms. A crowd of journeyman tailors had wrecked them as a threat to their livelihoods. In the United States of the 1850s there was no comparably powerful and politically active craft organization. To the contrary, America was already leading the world in



production of ready-made garments; even before the Civil War, companies were using standardized measurements and patterns to remove the most skilled and best-paid parts of tailoring from the manufacturing process. Jacksonian Americans hoped ready-made clothing of mechanically spun and woven fabrics would limit visible class distinctions in public life, closing the gap between the custom tailoring of middle- and upper-class men and the rough workman's clothing called slops. In 1835, one New York firm was advertising for three hundred male and five hundred female tailors, and another for twelve hundred "plain sewers."

Such manufacturers embraced mechanical sewing rapidly, as it increased productivity by up to 500 percent. From 1853 to 1860 the number of machines sold in the United States rose from 1,609 to 31,105, reaching 353,592 by 1875. But domestic applications soon overtook industrial uses. Isaac Singer, a former actor, pioneered a national and international sales campaign to introduce his machine into the home. Singer's associate, the attorney Edward Clark, developed the first national sales organization and the first widely accepted hire-purchase plan, successful even among buyers who could have paid cash. Since women of all social classes were expected to sew and repair women's and children's clothing, it appeared to offer a great savings in time. Its high price actually helped make it a prestigious purchase, usually on prominent display—one of the first manifestations of an industrial aesthetic in the home. (The Singer machine contained over one hundred pounds of cast iron, among other materials.) Yet working-class women who could afford payments also saw it as a means of self-sufficiency; for young women it was an attractive alternative to domestic service.

Clark and Singer established luxurious sales rooms for displaying machines and their use, spent millions in advertising, and established global sales and service organizations, the first of their kind. Economic historians have suggested that the vigorous marketing by Singer and other firms spread information that, in turn, stimulated new improvements of the machine in a virtuous circle. They have also noted that the Singer Company continued to use conservative, European-style craft production systems after its rivals had adopted interchangeable parts, making the change only when sales volume demanded it. Despite this delay, the sewing machine industry became a new foundation of productive techniques that helped U.S. industry challenge Britain's dominance in mechanical engineering.

The sewing machine reached maturity relatively quickly. The 1865 Singer New Family machine was sold into the twentieth century, and some home sewers still swear by the robustness of related surviving models. After the original patents expired in 1877 and the combination of patent holders was dissolved, prices continued to drop. Sears, Roebuck and other new merchandisers aggressively promoted well-built and relatively inexpensive private-brand machines. While this strategy helped

maintain real-dollar sales and widespread home sewing machine use, it also hastened the decline of the sewing machine's status. Meanwhile technicians and inventors who worked in sewing machine production were turning design and production skills to new generations of devices, including typewriters (which offered similar challenges in precise alignment) and phonographs (which also used rotary motion and the needle).

Motor-powered machines began to appear in the 1910s, but until the 1930s many potential customers outside major cities still lacked home electricity. The great change in the early twentieth century was in attitudes toward home sewing and the machine. The increased availability, improved styling, and higher quality of ready-made women's clothing turned the sewing machine from a time-saver to a money-saver. Homemade clothing began to be stigmatized. In the 1920s, domestic management shifted from making to selecting things. Electrification of factory sewing machines reinforced this trend by increasing productivity and reducing the prices of ready-made clothing. And the expense of materials wasted by mistakes discouraged neophyte home sewers. Ironically, electrification was welcome in part because it made it easier to hide the machine on a closet shelf between uses.

Expanding career opportunities for women after World War II made the domestic sewing machine a niche appliance, sometimes used as a fallback during price inflation and for mending. With the rise of solid-state control, using programmable integrated circuits instead of or in addition to mechanical controls like cams and with the globalization of the apparel and footwear industries, sewing machine production moved in the later twentieth century first to Japan and then to China. The division of labor in industry encouraged the multiplication of special-purpose machines, of which Japanese firms in the 1990s offered over one thousand models. High-speed production is posing a new range of technical challenges; needles, threads, and fabrics must be designed to work with advanced equipment. (Some economists believe that stronger thread for machine sewing was one of the twentieth century's most productive innovations.)

In home sewing, computerization has encouraged not output but creative control, in that a new variety of stitches and functions are available. High-end home machines can exceed the cost of some industrial machines in price. The attraction is no longer saving time or money, but creating apparel and home furnishings with designs unavailable in the marketplace. In the global economy pioneered by the sewing machine, household and industrial sewing have parted ways again.

See also **Needles; Seamstresses.**

#### BIBLIOGRAPHY

Burman, Barbara, ed. *The Culture of Sewing: Gender, Consumption, and Home Dressmaking*. Oxford and New York: Berg, 1999.

- Connolly, Marguerite. "The Disappearance of the Domestic Sewing Machine, 1890–1925." *Winterthur Portfolio* (1999): 31–48.
- Cooper, Grace Rogers. *The Sewing Machine: Its Invention and Development*. Washington, D.C.: Smithsonian Press, 1976.
- Godfrey, Frank P. *An International History of the Sewing Machine*. London: Robert Hale, 1982.
- Hounshell, David. *From the American System to Mass Production, 1800–1932: The Development of Manufacturing Technology in the United States*. Baltimore: Johns Hopkins University Press, 1984.
- Jensen, Joan M., and Sue Davidson. *A Needle, a Bobbin, a Strike: Women Needleworkers in America*. Philadelphia: Temple University Press, 1984.

*Edward Tenner*

**SEYDOU, CHRIS** Chris Seydou (1949–1994) was a pioneer in promoting African fashion designers on the international stage. He created clothing that drew on his roots in Mali, West Africa, yet his designs evaded neat categorization as African. Seydou was well known for his adaptation of African textiles, including Mali's bogolan fabric, to haute couture. Seydou's bell-bottom pants, motorcycle jackets, and tight miniskirts made of distinctively African fabrics caused a stir in Mali and drew attention to his work abroad. Seydou's designs have been published in numerous French, German, Ivorian, and Senegalese as well as Malian fashion magazines. He showed his designs in Europe as well as Africa, and worked with internationally renowned designers, most notably Paco Rabanne.

### The Designer's Roots

Chris Seydou was born Seydou Nourou Doumbia on 18 May 1949 in Kati, a small town centered around a military base forty kilometers north of Bamako, the capital of Mali. Because Seydou's mother worked as an embroiderer, he was familiar with the tools of the clothing trade from an early age. His mother had copies of European fashion magazines that greatly impressed Seydou; he was fascinated by the photographs of elegant women in beautiful clothes (Seydou 1993). He left school to pursue his interest in fashion at fifteen. In 1965, his family apprenticed him to a local tailor. In 1968 Seydou relocated to Ouagadougou in Burkina Faso (then called Upper Volta), and the following year he moved to the cosmopolitan city of Abidjan in Côte d'Ivoire. He changed his name when he embarked on his professional career, adopting the name "Chris" as a tribute to Christian Dior, whose work had been a great influence on his early development. He kept the name "Seydou" in order to preserve part of the name his family had given him, thus creating a professional name combining the European and African influences that are apparent in his work ("Interview: Chris Seydou," p. 10).

Abidjan was in the forefront of African fashion design in 1969, and Seydou found great success in the city, designing clothing for many of Abidjan's wealthy and influential women. Seydou then spent seven years in Paris beginning in 1972, where he studied European couture. He met other African artists and designers in Paris, with whom he organized the *Fédération Africaine de Prêt à Porter* (African Federation of Ready-to-Wear Designers), an association that seeks to promote African designers on the international market. Seydou was also one of the three founders of the *Fédération Internationale de la Mode Africaine* (International Federation of African Fashion), which continues to provide an important forum for African designers. Seydou found that his work appealed to African women who sought clothes made in "la mode occidentale" (Western style), and that European women appreciated his "exoticism" (Seydou; and "Chris Seydou: Le roman d'une vie," p. 34). As Seydou explained, these women did not buy his work because he was African, but because he "brought an African sensibility" to his designs (Seydou 1993).

Seydou returned to his country of birth in 1990. He came to Bamako in search of "the authors, the origins" of "the real African traditions" (Seydou 1993). He was particularly interested in bogolan or bogolanfini, a cotton textile traditionally made for ritual functions in rural Mali, and known as mudcloth in North American markets. Seydou had begun to use the cloth while he was working in Paris in 1975–1976. He described his return to Paris in 1973 or 1974 after a visit home and finding in his suitcase several pieces of bogolan he had received as gifts. He was already familiar with the material from his childhood in Kati, but there he had associated it with hunters and local ritual practices rather than with his own interest in fashion. In unfamiliar Paris the familiar cloth was transformed into a souvenir—a reminder of the place and the people of home (Seydou 1993).

### Transforming Traditions

Seydou's work with bogolan and other indigenous textiles illustrates the balance between local tradition and global markets that characterizes the work of many non-Western designers. Seydou focused on making Malian fabrics relevant to contemporary fashion rather than preserving local traditions. Yet the cultural significance of the textiles shaped his methods, as illustrated by his work with bogolan. Seydou edited, modified, or discarded some aspects of the fabric while preserving others. "I am a contemporary designer who knows what I can do technically and how to do it. Bogolan can simply be a cultural base for my work" (Seydou 1993).

One of Seydou's primary modifications of bogolan concerned the density of its designs, for the fabric customarily incorporates a variety of distinct motifs. Cutting and assembling a garment from this cloth was extremely difficult for Seydou, for no two portions of a given piece of cloth are identical. Seydou adapted by commissioning



### THE CHRIS SEYDOU PHENOMENON

Journalists in Africa and Europe recognized Seydou's role as an ambassador between African and Western fashion worlds.

He flouted every convention, showing bogolan made into mini-skirts or bustiers, as large berets or full-fitting coats and even as a fitted suit worn by the President's wife Adame Ba Konaré for the opening of a film festival in Marseilles in 1993. (Duponchel, p. 36)

À travers ses créations, le Mali s'est fait mieux connaître dans ses valeurs culturelles à travers le monde, jusqu'en Amérique où les Noirs américains font aujourd'hui du bogolan une source d'identification culturelle. (Through his creations, Mali became better known throughout the world for its cultural

treasures, all the way to America where black Americans today make bogolan into a source of cultural identity) (Diakité, p. 4).

Chris Seydou en fut le premier artisan, faisant naître une génération de stylistes de premier niveau, tous visionnaires d'une Afrique renaissante... (Chris Seydou was the first..., breeding a generation of first class designers, visionaries of a born again Africa) (Pivin, p. 7–8 Trans Gail de Courcy-Ireland).

It all began with the unforgettable, incomparable Chris Seydou. More than anyone, he helped to give African men and women a new way of thinking, of looking at things, and inspired numerous designers and models to aim even higher. (Traoré, p. 8).

his own versions of bogolan, isolating a single pattern in a process he referred to as "decoding" the cloth. Seydou also expressed reluctance to cut and tailor material that was adorned with symbolic motifs, out of respect for the cloth's ritual significance in the context of rural Mali: "For me it was symbolic. For me, I didn't want to cut bogolan early on; it was difficult to put my scissors to it." (Seydou 1993). Among Seydou's most popular and influential bogolan-related projects was his 1990 collaboration with the Industrie Textile du Mali, a textile manufacturing company in Bamako, for which he designed a fabric inspired by bogolan that was printed and sold in 1990–1991. Seydou's death in 1994, at the age of 45, reverberated powerfully in the worlds of fashion, art, and popular culture throughout west Africa and beyond. He is considered by many to be the father of African fashion design.

See also **Afrocentric Fashion; Bogolan; Dior, Christian; Ethnic Style in Fashion; Rabanne, Paco; Textiles, African.**

#### BIBLIOGRAPHY

- "Chris Seydou: Le roman d'une vie...." *Africa International* 271 (July–August 1994): 31–37.
- Diakité, K. B. "Chris Seydou." *L'Essor* 12673 (8 March 1994): 4.
- Domingo, Macy. "Ivory Scissors—Ciseaux d'Ivoire." *Revue noire* 2 (September 1991): 6–7.
- Duponchel, Pauline. "Bogolan: From Symbolic Material to National Emblem." In *The Art of African Textiles: Technology, Tradition and Lurex*. Edited by John Picton. London: Barbican Art Gallery and Lund Humphries, 1995.
- "Interview: Chris Seydou." *Grin-Grin: Magazine mensuel des jeunes* 9 (April–June 1989): 10.
- Pivin, Jean-Loup. "Renaissance d'un style africain" (Rebirth of an African Style). Translated by Gail de Courcy-Ireland. *Revue noire* 27 (December 1997–January 1998): 7–8.

Rovine, Victoria. *Bogolan: Shaping Culture through Cloth in Contemporary Mali*. Washington, D. C.: Smithsonian Institution Press, 2001.

Seydou, Chris. Interview by author. Bamako, Mali. 6 March 1993.

Traoré, Aminata Dramane. "African Fashion: A Message." In *The Art of African Fashion*. Edited by Els van der Plas and Marlous Willemsen. The Hague, Netherlands: Prince Claus Fund; Asmara, Eritrea, and Trenton, N.J.: Africa World Press, 1998.

Victoria L. Rovine

**SHATOOSH.** See **Cashmere and Pashmina.**

**SHAWLS** The shawl as an item of female fashionable dress derives from the Indian *shal*, which is a male garment that consists of an unstructured length of material with woven or embroidered patterning. The first shawls worn by Europeans in India or elsewhere, were worn by men, although this practice mainly involved those connected to colonial trade. Britain had strong trading links with India from the late seventeenth century, and after 1757 the British East India Company "was inextricably involved in effective colonization" (Morgan, p. 460). These historic developments generated a huge fascination with Indian culture in Britain, which was expressed partly by an enthusiasm to consume new "exotic" luxuries such as the *shal* (Morgan, p. 460).

#### Female Fashionable Dress

The emergence of neoclassical dress as informal wear in the 1760s greatly contributed to the embrace of the shawl within fashionable dress. Female neoclassical dress was made from flimsy, lightweight materials and it referred





For a long time English fashions have formed part of those of France. The shawls, a type of unusually ample handkerchief, hail from India, where they replace mantles. Adopted by the English, they have come to France and go rather well with fashionable undress. (*Journal de la Mode et du Gout*, pp. 1–3)

back to the draped elegance of ancient Greek and Roman dress. Therefore, it was perfectly complemented by the warm and gracefully draped shawl. The shawl was adopted in Britain from the 1760s through the 1770s and by the 1790s it was also highly fashionable in France. Initially the Indian shawls were only worn by the upper classes, as they were very expensive, so much so that they were often treated as family heirlooms. However, the fact that they were highly desirable luxuries meant that by the 1820s cheaper copies were made widely available to middle-class consumers. Good-quality shawls were prized possessions and they were often used as gifts linked to weddings and baptisms. As the nineteenth century progressed, increases in the range of designs and prices available, meant that the associations of wealth, class, and respectability linked to a particular shawl and how it was worn became more complex. Retailers catered to this diversity; for example, the firm J. & J. Holmes, of London, offered a wide range of designs and prices from 1 guinea to 100 guineas. Efforts by manufacturers to create still cheaper shawls meant that they were worn by working-class women, and even the very poor wore second-hand or coarse woolen versions.

### Materials, Production, and Patterns

Genuine cashmere shawls were made from the fine, silky underfleece of the Himalayan mountain goat, which was a rare and expensive fiber. British and French manufacturers who aimed to copy the Indian shawls attempted to imitate this fiber in various ways—for example, by using different combinations of wool and silk. Methods of manufacture also created distinctive differences between Indian- and European-made shawls. As Sarah Pauly notes, “European shawls, whether woven on the drawloom or the Jacquard loom, were always machine-woven, while the Indian product was always made by hand-manipulated weaving (when not embroidered)” (p. 20). The result of this was that the design and construction of European shawls was limited by machine capabilities. From 1824, the introduction of the Jacquard loom enabled more sophisticated designs to be produced than previously possible on the drawloom. However, no machine could match the immensely complex and time-consuming double-interlocking twill-tapestry technique used by the Kashmiri weavers, which was only possible by hand.

Another singular feature of the Indian shawls was the pine or cone pattern, which was a stylized interpretation of a flowering plant, known as a *buta*. This design was also linked to Arab culture, as many of the Kashmiri weavers came from Persia. In the nineteenth century the pine became the distinctive motif of the Paisley shawl, a pattern that became even more stylized after the introduction of the Jacquard loom. Three other early shawl designs that remained popular until the 1870s were the spade center, the blue-style, and the zebra. Despite the dominance of Indian-inspired patterns, the ubiquity of the shawl from the 1820s meant that many different fancy designs were also worn.

### Important Shawl Manufacturing Centers

The most notable British centers for the weaving of shawls in the period discussed were Paisley, Norwich, and Edinburgh. Norwich and Edinburgh manufacturers experimented in the 1790s with producing good, cheaper imitations of the Indian shawls. Despite their relative success in producing high-quality copies, these efforts were soon overshadowed by Paisley in Scotland, which became a thriving international center for the production of shawls from about 1805 to the early 1870s. Leading Paisley manufacturers, such as John Morgan & Co., Forbes and Hutcheson, and J. J. Robertson, were successful in bringing the shawl to a mass market of consumers, largely because they were cheaper than their rivals. Despite its Indian derivation, the stylized pine design has since become internationally known as the Paisley pattern.

In France, manufacturers in Lyons, Paris, Jouy, and Nîmes also began making shawls from the early nineteenth century. French shawls tended to be of high quality of both design and manufacture; they were renowned as being second only to the Kashmir shawls of India.

### 1870 to the Early 2000s

The shawl ceased to be a ubiquitous fashion item from the 1870s, owing to the introduction of the fitted bustle style. It regained popularity in the twentieth century as an element of formal evening dress; however, in general it has had a minimal presence within the fashionable female wardrobe. The mid to late-1990s witnessed a brief period of fashionability for the pashmina, a cashmere shawl usually made in attractive, plain colors.

See also **Sari**; **Scarf**.

### BIBLIOGRAPHY

- Alfrey, Penelope. “The Social Background to the Shawl.” In *The Norwich Shawl*. Edited by Pamela Clabburn. London: HMSO, 1995.
- Clabburn, Pamela, ed. *The Norwich Shawl*. London: HMSO, 1995.
- Journal de la Mode et du Gout*. No. 11 (5 June 1790): 1–3.
- Lochrie, Maureen. “The Paisley Shawl Industry.” In *Scottish Textile History*. Edited by John Butt and Kenneth Ponting. Aberdeen, Scotland: Aberdeen University Press, 1987.

Mackrell, Alice. *Shawls, Stoles and Scarves*. London: B. T. Batsford Ltd., 1986.

Morgan, Kenneth O. *The Oxford History of Britain*. Oxford and New York: Oxford University Press, 1992, 2001.

Pauly, Sarah. *The Kashmir Shawl*. New Haven, Conn.: Yale University Art Gallery, 1975.

Perrot, Philippe. *Fashioning the Bourgeoisie: A History of Clothing in the Nineteenth Century*. Princeton, N.J.: Princeton University Press, 1994.

Fiona Anderson

**SHIBORI.** See Tie-Dyeing.

**SHIRT** A shirt is a garment worn on the upper part of the body, usually consisting of a buttoned front, a collar, and long or short sleeves. Possibly the most important item in the male wardrobe after the suit, the shirt has always been considered the symbol of a gentleman. The finest shirts are single-stitched, pleated at the cuff, and feature a split shoulder yoke to allow for different heights of each shoulder.

### History

Shirts appeared first in European dress in the seventeenth century as a kind of underwear, designed to protect expensive waistcoats and frock coats from sweat and soil. By the early eighteenth century, shirts had assumed importance as garments in their own right. The emphasis placed by Beau Brummel and other dandies on wearing clean, perfectly styled linen brought the shirt into increased prominence as an essential male garment. Before the middle of the nineteenth century, only those considered to be gentlemen could afford to wear white shirts, as only they had the means to buy, change, and wash them regularly. Because shirts soiled so easily, men involved in manual labor found it completely impractical to wear them. The development of improved laundry techniques after the mid-nineteenth century expanded the market for shirts, but they remained emblematic of upper-class, or at least “white-collar” middle-class men.

At first, shirts were put on by being pulled over the head. Shirts that opened all the way down the front were unknown before 1871, when Brown, Davis & Co. of Aldermanbury registered the first “coat style” of shirt. Striped shirts became fashionable in the late nineteenth century, but some viewed them with the suspicion that the color was hiding dirt.

In the early twenty-first century, a similar style of shirt to those originally produced by Brown, Davis & Co. is available in either plain or placket front. The placket is used to give the shirt extra strength and consists of an extra fold of fabric where the shirt is buttoned. Other essential requirements for a shirt of the highest quality include gussets for reinforcement between the breast and the back of the shirt, mother-of-pearl buttons, and re-

movable collar bones (preferably made from brass) to prevent the collar tips from curling upwards. On the other hand, a good shirt will never feature a breast pocket as these only appeared much later with the demise of the waistcoat. Use of a shirt breast pocket to carry pens, cigarettes, and other paraphernalia can spoil the lines of the shirt. By the turn of the twentieth century, the traditional stand-up collar was supplanted by the turndown collar—a development that coincided with the demise of the cravat in favor of the necktie. Although there are as many as twenty different styles of collar (both attached or detachable), the most formal remains the broad turndown. With the rise of the Windsor tie knot (invented in the 1920s, and revived periodically), the cutaway collar has become the collar of choice for younger shirt wearers.

Although the word “shirt” has been expanded to include a number of men’s and women’s garments, with dress shirt, sports shirt, sweatshirt, T-shirt, and shirtwaist counted among them, a plain white shirt cut from the softest sea-island cotton is a sartorial must for any man. The tailored shirtwaister or shirtwaist blouse with starched and coat-style front is the women’s version that evolved from a man’s shirt, beginning in the late nineteenth century and enjoying great popularity beginning in the 1930s. Many formerly exclusively male shirt styles have been adopted essentially unchanged for women’s wear in the late twentieth century.

See also Neckties and Neckwear; Shirtwaist; Suit, Business; Tailored Suit; T-Shirt; Waistcoat.

### BIBLIOGRAPHY

Amies, Hardy. *A, B, C's of Men's Fashion*. London: Cahill and Co. Ltd, 1964.

Byrde, Penelope. *The Male Image: Men's Fashion in England 1300–1970*. London: B. T. Batsford, Ltd., 1979.

Chenoune, Farid. *A History of Men's Fashion*. Paris: Flammarion, 1993.

De Marley, Diana. *Fashion for Men: An Illustrated History*. London: B.T. Batsford, Ltd., 1985.

Keers, Paul. *A Gentleman's Wardrobe*. London: Weidenfield and Nicolson, 1987.

Roetzel, Bernhard. *Gentleman: A Timeless Fashion*. Cologne: Konemann, 1999.

Schoeffler, O. E., and William Gale. *Esquire's Encyclopedia of 20th Century Fashions*. New York: McGraw-Hill, 1973.

Tom Greatrex

**SHIRTWAIST** The shirtwaist dress, also known as the shirtmaker or simply the shirtdress, is one of the most American of all fashions. It has endured throughout the entire twentieth century into the early twenty-first. It owes its origins to the shirtwaist blouse, that very early product of the American ready-to-wear industry that emerged as part of the uniform of the New Woman in the 1890s. Its styling is based on a man’s tailored shirt



**Advertisement for McMullen shirt frocks.** The shirtwaist has been known by many names since its development in the late twentieth century. The McMullen Company helped popularize the style when it introduced its “shirt frocks” in 1935, in an attempt to overcome declining sales in men’s dress shirts. Courtesy of The Chapman Historical Museum. REPRODUCED BY PERMISSION.



with a skirt added, either as a one-piece dress or as separates. If separate, the skirt and shirt are usually made from the same material.

It began as a practical, washable nurse's uniform, usually cotton, sometime around the turn of the twentieth century and continued in this mode into World War I, where it became the uniform for the Red Cross and other organizations needing practical, washable clothing for their women workers.

Trim and becoming, the shirtwaist's practicality lent itself to the postwar enthusiasm for active sports, and by the 1920s, occasional "sports dresses" based on it but not using the name were adopted for golf and tennis. Caroline Millbank notes that by 1926, Best & Co. promoted what they called their "shirtmaker frocks" for sports, made of cotton and ready to be monogrammed. As a fashion, it hit its stride in the 1930s, in large part because of the upscale men's shirt manufacturer, the McMullen Company of Glens Falls, N.Y. who, in its attempt to overcome the falling market in fine men's shirts during the Depression, introduced to the retail industry a line for women, the "shirt frock," in 1935. These were two-piece cotton, linen, or lightweight wool dresses, with choices of either skirts or culottes that looked like skirts.

The term "shirtwaist," derived from "waist," the nineteenth-century term for what we would now call a blouse (in itself so-called because it bloused over the waistband as it was tucked into the skirt), was commonplace by the 1890s. However, the name as applied to sports dresses was not generally used until considerably later. Women's magazines from the 1930s and into the 1940s referred to it rather clumsily as "the button-down-the-front style" or, more vaguely, the "sports dress" even as they acknowledged that it had become a classic of American style. In a very early version, *Simplicity Patterns* offered a "shirtmaker" in 1937, but *The Ladies' Home Journal* did not consistently use the name in their articles and advertising until sometime around 1941, and even Best & Co. called its dress a "golfer" that same year. However, a major article in *Life* (9 May) on "Summer Sports Style" devoted two full pages showing 18 illustrations of various "classic shirtwaists," in all price points and in both day and evening wear. By so doing, perhaps they helped to codify the name that has stuck. Full-skirted versions following the New Look's dictates became the outfits of choice for the American housewife of the 1950s and early 1960s. Later in the century, in the late 1970s and 1980s, Geoffrey Beene and Bill Blass took it to a new and elegant high, introducing the classic shirtmaker in luxurious and unusual fabric combinations for evening wear. It continues to remain staple of American style in the twenty-first century, by now a conservative classic whose practicality and versatility make it a necessary part of many women's wardrobes.

See also **Beene, Geoffrey; Blass, Bill; Blouse; New Look; Shirt; Ready-to-Wear; Uniforms, Sports.**

#### BIBLIOGRAPHY

- Ladies Home Journal*, February 1938, p. 63.  
 Millbank, Caroline Rennolds. *New York Fashion: The Evolution of American Style*. New York: Harry N. Abrams, 1996.  
 Payne, Winakor, and Jane Farrell-Beck. *The History of Costume*. 2nd edition. New York: HarperCollins Publishers, 1992.

*Patricia Campbell Warner*

**SHOEMAKING** Shoemaking continues to be the work of a family member in many cultures of the early 2000s. Inuit and other circumpolar peoples continue the tradition of footwear production by the mother of the family—the craft learned from her mother and passed on to her daughters, as it has always been.

The earliest professional shoemakers can only be supposed from Egyptian friezes where laborers are depicted making sandals, using tools not dissimilar to tools still used by hand shoemakers. However, leatherworkers also used the same tools as the shoemaker, and so it is impossible to define the period in which shoemaking as a singular profession developed.

During the Roman Empire shoemaking progressed from artisans working alone in small settlements to congregating in streets near the town's center or marketplace, where guilds became established. Guilds protected and regulated the shoemakers, their suppliers, and their clients from unfair business practices and pricing, and ensured quality products. Apollo was chosen patron deity of Roman shoemakers, with images and statues of him gracing the entrance to streets reserved for members of that profession.

Similarly, images of the Christian patron saints of shoemakers adorned the churches and guildhalls of medieval Europe. During the third century, noble Roman brothers Crispin and Crispinian were converted to Christianity and went to Gaul to preach the gospel, working as shoemakers at night. They were eventually tortured for their faith and put to death. Although the legend is unreliable and Saints Crispin and Crispinian have lost their status of sainthood, they have remained the patron saints of shoemakers since the fifteenth century, and their feast day, October 25, is still celebrated as a holiday for the shoe industry in France.

There is evidence that by the fourteenth century, shoemakers were already making footwear for speculative sale, essentially "ready to wear." This was aided by the adoption of standardized measurement. In England in 1324, measurements for distance were standardized under King Edward II. Consistent in size, three barleycorns laid end-to-end equaled one inch and the foot-long "ruler" became the foot measurement of King Edward, the ruler of England. The other standard of measurement was the hand, used since biblical times, and used to this day for measuring the height of horses. A hand equals  $4\frac{1}{8}$  inches or 13 barleycorns. When a standardized mea-



**Jimmy Choo.** Fashion clothing and footwear designer Jimmy Choo in his London workshop, 1997. © TIM GRAHAM/CORBIS. REPRODUCED BY PERMISSION.

surement for shoe sizing began in the late seventeenth century, children's sizes were deemed to be less than the measurement of a hand and adult sizes were those over a hand. Adult sizes began with the deduction of  $4\frac{1}{3}$  inches, so an adult woman's size 4 shoe means it is made for a foot  $8\frac{1}{3}$  inches long. Under Louis XIV the Paris Point system was standardized as  $\frac{2}{3}$  centimeter, and became the standard for most of Europe, but Germany continued to follow the English measuring system.

By 1400 most large European cities had shoemakers' guilds. This did not include cobblers, who were shoe repairers and not part of the shoemakers' guild. Shoemakers are capable of doing repairs but this is considered inferior work. In England shoemakers were more properly known as *cordwainers*, and in France as *cordonniers*, after the fine Cordwain leather tanned in Cordoba, Spain, and imported in great quantities. Their very name suggested the quality of their goods.

### Shoemaking 1600 to 1850

In the late sixteenth century, welted shoe construction became standard whereby the upper was sewn to a welt with a second row of stitches made through the welt into the outer sole. From this development until the intro-

duction of machinery in the mid-nineteenth century there is very little change in the tools or methods used for shoemaking. And for hand shoemakers, changes in this tradition have been minimal. The tools to achieve this construction consisted of a knife, last, dogs, hammer, awl, and shoulder stick.

The first and most important step in making a shoe is to measure the foot accurately, translating these measurements to a corresponding wooden last. The word *last* comes from the old English word for foot and is the wooden form used as a mold for making the shoe. The last is made to the same shape and size as the client's foot, or a standard last is adjusted adding built-up layers of leather to attain the same measurements. The last is frequently made up of at least two pieces, so that it can be more easily removed from the finished shoe.

After measuring the foot and translating those calculations onto a pattern, cutting out, or *clicking*, the leather is the first step in constructing a pair of shoes. The round, or moon knife is an early tool that can be seen as far back as ancient Egypt. Used by most workers in leather until the nineteenth century, the skill to use it to its full advantage was acquired during apprenticeship. Straight knives were also used but it was only with the



**An eighteenth-century shoemaker's shop.** This diagram from the *Dictionary of Sciences* (1770) depicts the shoemaking technology and tools of the day. Standardized measurements helped ensure a good fit for length in shoes, and pre-made footwear may have already been in production by the late 1700s. © HISTORICAL PICTURE ARCHIVE/CORBIS. REPRODUCED BY PERMISSION.

mass entry of workers into the shoe factories of the nineteenth century that straight knives and scissors were preferred by the less-skilled labor force, resulting in the extinction of the moon knife.

Lasting pincers or *dogs* are used for pulling the top of the shoe, or upper, tight around the last so that it may be secured with tacks to the underside. Most dogs have serrated teeth that help to pull the upper taut and often have a hammer's peen on the other side to set the tacks so that the welted shoe can then be sewn. A hammer is rarely used to set the tacks into the last but rather is used for *peening* the leather. Once soaked, leather is hammered to flatten the fibrous tissues creating a surface that is more resilient to wear and dampness.

Shoes are traditionally not sewn with a needle, but rather holes are created using awls through which a waxed linen thread is inserted with a pig's bristle. The shapes of awl blades vary according to their intended use. A stitching awl has a straight blade and is used for making holes through multiple layers of leather. The closing awl has a curved blade and is used for joining the sole to the upper.

The shoulder stick, made of wood, burnished the welt and edge of the sole after the shoe was sewn, trimmed, and waxed. The shoulder stick was displaced in the nineteenth century with the use of heated irons, which did the same job but more quickly.

Heels began to be added to footwear beginning in the 1590s. Lasts are required to obtain the correct slope of the sole to accommodate the lift of the heel and as it is too expensive to have a huge inventory of lasts representing the various heel heights as well as for each foot, so most footwear would now be made without left or

right definition. This practice of making shoes with straight soles would remain for the next two hundred years, gradually falling from favor throughout the nineteenth century and only finally disappearing in the 1880s. Many surviving examples of lightweight leather and textile footwear from this period show evidence of wear on the uppers where the widths of feet have splayed the upper onto the ground where the sole was insufficiently narrow. However, sturdy leather footwear, like riding boots, continued to be made to order with left and right foot definition for fit and comfort.

With standardized shoe measurements well established and the ease of production for shoemakers of straight soles, it became profitable for shoemakers to pre-make quantities of footwear. No doubt when the shoemaker was not employed by client's orders, he created shoes for speculative sale. Extant shoes dating as early as the 1740s and increasingly toward the end of the eighteenth century display sizes written on linings, suggesting pre-made footwear, as well as shoemaker's names printed on paper labels, usually with their address, suggesting an attempt by shoemakers to encourage repeat business. Footwear had become the first ready-to-wear clothing article sold through shoemaker shops, and also haberdashers and "cheap shoe" warehouses, another name for off-the-rack retailers. Standardized measurements ensured a good fit for length, but it would not be until the 1880s that American shoe manufacturers introduced width sizing.

Shortages of military footwear, and in fact all leather footwear, were a problem in the late eighteenth and early nineteenth centuries. According to period journals, boots



and shoes from fallen soldiers were usually taken for reuse at the battle's end. All sides suffered from a lack of product, and methods to bypass the long years of apprenticeship to make a proficient shoemaker were sought. Improvements in the pantograph allowed for mirror images of lasts to be made proficiently, allowing for sturdy leather footwear to be made economically on speculation. The English developed a sole-riveting machine for military footwear in 1810 and also devised a press for cutting out leather around the same time. The French improved quotas by streamlining elements of construction, using a factory method for cottage production. Americans devised soles attached with wooden pegs rather than stitching, a process that had been used since the sixteenth century for attaching heels and repairing soles. And in 1823, the metal eyelet was introduced, eventually displacing the more time-consuming task of hand stitching lace holes.

### Shoemaking 1850 to the Present

By 1830, exports of women's footwear from France and men's footwear from England dominated the fashionable marketplace. Shoemaking centers were now firmly established in Paris and Northampton, but the United States, whose shoe industry was centered in and around Lynn, Massachusetts, was about to change everything. Factory-style mass production using semi-skilled workers could undercut imported goods and with the American perfection of the lock-stitch sewing machine by 1860, shoes could be made as quickly as the machine-sewn uppers could be attached to the soles.

The invention of the sewing machine was primarily initiated by the need for sewing leather, not cloth, more proficiently. Chain-stitching machines were introduced in early French shoemaking factories in the 1830s, resulting in Luddite-like revolts by workers who smashed the machines in fear of losing their jobs to technology. However, chain stitching was found to be more suitable for decorative work than seam construction. It was the American Isaac Singer's patented lock-stitch sewing machine for leather in 1856 that was to begin a series of major changes to the shoemaking industry over the next thirty years.

In 1858 the McKay Closing Machine was perfected that sewed the sole to the upper efficiently without the need of a trained shoemaker. The Goodyear welting machine, developed in 1875 by Charles Goodyear Jr., the son of the man who invented the process of vulcanizing rubber, imitated the difficult stitching of a leather shoe through an upper, welt, and sole. Unlike the McKay closing machine, a Goodyear welting machine did not puncture the bottom of the sole, resulting in a suitable walking shoe for outdoor wear. The Lasting machine, invented in 1883 by Jan Matzelinger, copied the multiple motions of pulling leather around a last and tacking it into position—a time-consuming job.

These machines, all invented in the United States, secured the American ability to mass-produce footwear,

as shoes could now be made at great speed and little cost. By the end of the nineteenth century, American shoes were flooding every market. Even the American idea of shoe boxes allowed for more efficient stock management and exporting of goods to Europe and the rest of the world. The European tradition of hand shoemaking was all but ruined.

Some European shoemakers survived the onslaught of cheaper American footwear by catering to the elite, creating footwear of exceptional quality and beauty. However, this worked for only a few small shoemakers. In order to survive, many European shoe companies modernized their factories, fitting them out with the latest machinery to compete with American goods, and many were successful, such as Clarks in England, Bally in Switzerland, Pelikan in Germany, and Bata in Czechoslovakia.

Through a changing workforce and insecure economy due to World War I, postwar recession, and the Great Depression, many shoe companies found it difficult to survive. However, a new process for cemented, or glued, soles in the mid-1930s brought production costs down and eliminated the need for many of the American machines. The 1930s put a focus on women's shoes in the wardrobe, now fully visible under shorter hemlines and thus a necessity for the fashion conscious. The importance of style, color, and decoration enabled European manufacturers the chance to regain supremacy. Companies such as I. Miller and Delman in the United States now saw competition from manufacturers such as Charles Jourdan in France, Rayne in England, and Ferragamo in Italy, who catered to a fashion-conscious clientele.

World War II changed the focus from style to durability. Shoe manufacturers did not suffer, because they were kept busy producing military footwear and other goods under military contract, but fashion footwear was limited by availability of materials.

As part of their postwar recovery, the Italian state aided indigenous shoe companies that were less wieldy than the huge American shoe manufacturers. Undercutting production costs, Italian shoe manufacturers quickly found a niche in the high-fashion footwear industry. By the 1960s French designers were going to Italy to have their shoes made, bypassing their own shoe-manufacturing nationals. Similar sized and modeled companies in Spain and South America with access to cheap and plentiful hides also found success in the 1970s and 1980s, at the cost of American, English, German, and French shoe manufacturers.

But the death knell for many American and European shoe manufacturers came in the development of Southeast Asian shoe industries in the late 1950s and 1960s. Cheaper labor costs for traditionally sewn footwear combined with the new slush molded plastic footwear, which could be produced by machine alone, resulted in the most profitable center in the world for the production of sports shoes—the most popular shoe style since the late 1960s.

While hand shoemakers still exist in London, Venice, and other locales, their numbers are limited and their clients few. High-fashion footwear is produced with a modicum of skilled labor in the finishing; workers whose greatest skill is computer programming make most of the shoes of the early 2000s. Cost, durability, and branding are what drive footwear production in the twenty-first century.

See also **Inuit and Arctic Footwear; Ready-to-Wear; Sewing Machine; Shoes; Shoes, Children's Shoes, Men's; Shoes, Women's.**

#### BIBLIOGRAPHY

- Bondi, Federico, and Giovanni Mariacher. *If the Shoe Fits*. Venice, Italy: Cavallino Venezia, 1983.
- Durian-Ress, Saskia. *Schube: vom späten Mittelalter bis zur Gegenwart Hirmer*. Munich: Verlag, 1991.
- Ferragamo, Salvatore. *The Art of the Shoe, 1927–1960*. Florence, Italy: Centro Di, 1992.
- Rexford, Nancy E. *Women's Shoes in America, 1795–1930*. Kent, Ohio: Kent State University Press, 2000.
- Swann, June. *Shoes*. London: B.T. Batsford, Ltd., 1982.
- . *Shoemaking*. Shire Album 155. Jersey City, N.J.: Parkwest Publications, 1986.
- Walford, Jonathan. *The Gentle Step*. Toronto: Bata Shoe Museum, 1994.

*Jonathan Walford*

**SHOES** Neil Armstrong uttered, “One small step for man—one giant leap for mankind” upon his first step on the moon on 20 July 1969. In Teflon-coated nylon and rubber boots, Armstrong became the first man to come into contact with an unknown, hostile extraterrestrial environment. Ten thousand years earlier, dwellers of caves in the Pyrenees emerged from the Ice Age also wearing footwear, made from the hides of the animals they hunted, to protect them from the elements and environment.

Footwear's primary purpose is to protect, but in 10,000 years of history, footwear has taken nearly every form possible to service and compliment human bodies, influenced by environment, morality, practicality, economy, and beauty. Footwear is literally the foundation of fashion. It is the only article of clothing required to come into regular contact with the earth, taking the punishment of hundreds of pounds per square inch with every step. At the same time, it is usually expected to resist dampness, comfort the foot, last a long time, and also look attractive.

Footwear has been the subject of literature and folklore. From Cinderella and Dutch clogs laid out for Sinter Claus, to tying shoes to a newlywed's car bumper, and fetish boots—footwear is steeped in tradition and cultural meaning. From biblical times, the sandal or slipper has been used as a symbol. The Assyrians and Hebrews gave a sandal as a token of good faith and to signify the trans-

fer of property. In Jewish ritual, the shoe represents wealth as when a loved one dies, the grieving family goes shoeless during the shivah as a sign of poverty, for without the deceased they are poor.

#### Five Basic Styles

Hot, dry climates generally saw the development of the sandal. Believed to be the world's first crafted foot covering, the sandal was a basic footwear style of the ancient Egyptians of the Nile valley and the Anasazi of the ancient American Southwest. Sandals have been the dominant footwear of Africa, Asia, and Central and South America. Their firm soles protect the feet from scorching surfaces, while the minimal uppers allow air to circulate. Sandals can be made of almost any material that is readily at hand, from woven grasses and leather to wood and even metal.

The moccasin, an Algonquian Native American word for footwear, is essentially a shoe made up of one piece of hide drawn up around the foot and sewn with no seams on the lower part. Moccasin-like foot coverings, gathered on top of the foot with a drawstring were the style of ancient northern Europeans. A descendant of this style survives in folk dress from the Balkans to the Baltic, most often referred to by its Croatian name—the *opanke*.

The shoe may have been the result of a union between the Roman *sandallium* and the *opanke* of northern Europe, essentially being a closed sandal. However, it is most aptly traced to the Christian Copts who developed the turnshoe in the first century. The turnshoe was made, as the names suggests, inside out and turned, with a seam along the edge of the hard sole attaching to the upper. Improvements to this style developed in Europe during the twelfth century when a welt was sewn in the seam to aid the shoe in keeping out water.

Similar in construction, boots provide protection to not only the foot, but also the lower leg. It is conjectured that boots originated in arctic Asia and over time spread across the circumpolar region. Certainly, boots are the dominant traditional footwear for natives of the coldest regions on earth, but ancient examples from Mesopotamia, among many hot climate cultures, prove that boots can also offer protection from desert heat and scrubby brushlands, as well as insect and snakebites. Boots also developed in nomadic cultures where riders of horses or camels wore them to protect their legs from chafing.

Clogs most likely originated from the wooden-soled footwear discovered by the Romans to be worn in Gaul (ancient France). Their wooden-soled footwear was made for inclement weather, which is the origin of the modern word “galosh.” Similar overshoes were made throughout the medieval period in Europe to protect good footwear from the filth of the streets. By the fourteenth century a shoe carved from one piece of wood became common for many northern European peasants who required waterproof, warm, inexpensive, and long-wearing footwear.

All footwear is based on these five historic styles. Created for different ranks, rituals, occupations, and uses, footwear can take on many looks when made of different materials and ornamentation. And the main cause for change in footwear is fashion.

From the tenth to twelfth centuries, Europe emerged from the dark ages by uniting itself into nations and developing a mercantile capitalist economy. Crusaders, sent to free the Holy land from Islamic occupation, brought back technical knowledge and fineries from the Arabs, which whetted the appetites of nobles who craved more novelty. By the fourteenth century, quality cloth and fine leathers were being fashioned into shoes that were conspicuous displays of style and elegance, worn with the purpose of expressing personal status.

During the fourteenth century, a fashion for pointed toes spread across Europe. The style originated in Poland, as it became known as the *poulaine* or *cracow*. Edicts were proclaimed limiting its use according to the wealth and social standing of its wearer. When the style fell from fashion at the end of the fifteenth century, it was replaced by wide-toe fashions, known variously as the *hornbill*, *cowmouth*, or *bearpaw*.

A curious woman's fashion, which was at its height of popularity during the 1590s, was the *chopine*—a platform-soled mule that raised the wearer sometimes as high as 39 inches (one meter) off the ground. By the time this fashion had subsided in the early seventeenth century, heels had emerged as a standard addition to both men's and women's footwear.

As Europe positioned itself into nations of power and wealth, the elite distinguished themselves from the masses through conspicuous refinement and extravagant ornamentation. Through the Rococo and Baroque arts, a noble's status was visible in everything he or she did and wore. High-heeled footwear made of expensive silks expressed the idle lifestyles and accumulated wealth of the well heeled. Buckles became a fashionable way of closing shoes during the 1660s, and a century later these large and showy objects had become the feature of the shoe.

By the late eighteenth century, the industrial revolution had brought wealth to the middle classes and the French Revolution ended the divine right of the ruling monarchy. These events empowered the middle classes who would now become the brokers of taste. As everyone was now born on the same level, heels disappeared, fancy buckles were elitist and were replaced by shoelaces, and expensive silk footwear was displaced by more affordable and better-wearing leather footwear. The industrial production of shoes, beginning in the nineteenth century, made attractive, good-quality footwear affordable to almost everyone.

Fashion footwear became a commodity available to all levels of society. Its style was now disseminated through the new communicator—the fashion magazine. Elitism still existed by the quality of the shoe's con-

struction and decoration but what became the real elitist separator was the ability to remain “au courante.” Styles, materials, colors, and ornaments changed noticeably enough each season to keep the unfashionable out of the game.

See also **Boots; High Heels; Inuit and Arctic Footwear; Sandals; Shoes, Children's; Shoes, Men's; Shoes, Women's; Sneakers; Sport Shoes.**

#### BIBLIOGRAPHY

- Bondi, Federico, and Giovanni Mariacher. *If the Shoe Fits*. Venice, Italy: Cavallino Venezia, 1983.
- Durian-Ress, Saskia. *Schube: vom späten Mittelalter bis zur Gegenwart Hirmer*. Munich: Verlag, 1991.
- Ferragamo, Salvatore. *The Art of the Shoe, 1927–1960*. Florence, Italy: Centro Di, 1992.
- Rexford, Nancy E. *Women's Shoes in America, 1795–1930*. Kent, Ohio: Kent State University Press, 2000.
- Swann, June. *Shoes*. London: B.T. Batsford, Ltd., 1982.
- . *Shoemaking*. Shire Album 155. Jersey City, N.J.: Parkwest Publications, 1986.
- Walford, Jonathan. *The Gentle Step*. Toronto: Bata Shoe Museum, 1994.

*Jonathan Walford*

**SHOES, CHILDREN'S** Until recent times, footwear made for children generally mimicked the idiosyncratic styles of the adults of their time and place (taking into account the special characteristics of the feet of infants and young children). It was not until the twentieth century that footwear highly divergent from the dominant adult prototype evolved specifically for children. However, in premodern times there were some circumstances concerning children's footwear that are of historical interest.

In ancient Greece, sandals and slipper-like shoes predominated for both children and adults. Boys were “sandaled” around the age of seven when they first left their homes for school, a rite of passage similar to a boy's receiving his first pair of breeches in later eras. Young girls making their first departure from home, which took place with the girl's marriage shortly after reaching biological adulthood, also went to the shoemaker's for their first pair of sandals. A survey of Tanagra terra-cotta figures from the first half of the third century B.C.E. suggests that young children, perhaps specifically girls, wore slippers before their official departure from family life. There is much debate surrounding the question when and if children in ancient times were shod.

Swaddling, the practice of tightly wrapping the limbs of newborn infants, was widespread in Europe prior to the middle of the eighteenth century. However, when Jean-Jacques Rousseau published *Émile*, his polemic on “natural” methods of child rearing in 1762, swaddling was already on the wane. There was disagreement about whether children should wear shoes. Thomas Delaney, a



**Great athletes start here.**



At adidas, we make shoes for some of the world's greatest athletes. Now, with the same care and attention to detail, we

the Clipper, Tomado, Saturn and Scamp. As you'd expect, they're built to last. Which is really just as well



make shoes for children. They come in 12 styles, in lots of bright, fun colours and in sizes from 8 upwards. Pictured here, we have

when you consider what they might lead to.

**adidas** 

**Adidas shoes advertisement.** An advertisement for Adidas introduces a line of sneakers for children that are much like its adult models, but in colors and branding that appeal to children. THE ADVERTISING ARCHIVE LTD. REPRODUCED BY PERMISSION.

shoe advocate with a vested interest in shoe-wearing, suggested in his 1597–1600 book *The Gentle Craft* that shoes for the newborn should be part of the midwife's kit. On the other hand, Dr. William Cadogan in *Essay on Nursing* (1748) rails against the practice of swaddling but also contends that “Shoes and stockings are very needless Inconveniences” for the young (Cunnington, pp. 24, 33).

Archaeological artifacts from in and around medieval London (1100–1450) show how children's footwear reflected the dominant adult forms, but with slight differences. It appears that children's shoe styling lagged about fifty years behind the fashions of adults. The closures for children's shoes were designed more for practicality than for fashion, being usually on the center front vamp rather than style-consciously on the side. Fashion extremes, such as the *Poulaine* shoe with a long pointed toe, were more modest for children (Grew and De Neergaard). A case study showing that more than one style of footwear for children existed simultaneously can be found in seventeenth-century Boston, Massachusetts, specifically around the year 1670. Five portraits of young Bostonians circa 1670 are extant: the portrait of the Mason children at the De Young Museum in San Francisco and Alice Mason at the National Park Service

Adams Historic Site in Quincy, Massachusetts, and three portraits of the Gibbs children, Henry and Margaret Gibbs in private collections and Robert Gibbs at the Museum of Fine Arts, Boston. All of the portraits may have been painted by the same artist. Of the discernible footwear styles, the rounded toe and the square folded toe with setback sole can be differentiated. Archaeological evidence from the Nanny Privy Site in Boston from roughly the same date also reveals the possibility of multiple styles, a rounded toe, a square toe setback sole, and a possible variation of the square setback toe with equidistant triangular openings on either side of the toe (Butterworth, pp. 66, 67).

In *Emile*, Jean-Jacques Rousseau encouraged baring the child's feet. “Let *Emile* run about barefoot all the year round, upstairs, downstairs, and in the garden. Far from scolding him, I shall follow his example; only I shall be careful to remove any broken glass.” But raising a child “à la Jean-Jacques” sometimes had unwelcome results: “[T]heir hair straggles in a hideous and disgusting way ... They are longer checked, but clamber on to you with their muddy feet.”

In the nineteenth century as the making of shoes became more systematic, particularly in New England, evidence emerges of the development of particular styles of shoes for children. The Reverend Richard Manning Chipman noted, for example, that “cack” was a specific term developed in Massachusetts around the year 1820 for a baby's soft leather-soled heelless shoe. On the other hand, the *Oxford English Dictionary* discloses that the word “bootee” or “bootie” did not occur in popular English usage as a description of infant's shoes until its appearance in a Sears, Roebuck and Co. catalog in 1929.

Throughout the nineteenth century, periodicals encouraged women to try their hands at creating shoes for their young children. Patterns appeared in *Godey's Ladies' Book* (1830–1898), and *Peterson's Magazine* (begun 1842). In the anonymously written *The Workwoman's Guide* (1838), the author gives patterns and sewing directions for baby's first and second pair of shoes, as well as a pair made of ticking material (A Lady, pp. 173, 174). One hundred and fifty years after Monsieur Rousseau encouraged the possibility of childlike-children, footwear began to be developed specifically for them, albeit in the form of variations on already existing adult shoes. In 1890, George Warren Brown opened the Brown Shoe Company in St. Louis, Missouri, but it was not until the 1904 World's Fair that his variation on the Oxford tie for boys came into its own. In that year a young executive from Brown's company met artist Richard F. Outcault and the “Buster Brown” shoe was born. Of equal importance is Buster's sister “Mary Jane” who gave her name to the ubiquitous girl's low-strapped shoes.

Children's increasing participation in sports was an important twentieth-century development for their shoes. Keds, originally produced by the U. S. Rubber Company

and acquired by Stride Rite in 1979. They “were the first shoe mass marketed as a canvas-top *sneaker*” a word coined by Henry Nelson McKinney because “all other shoes, with the exception of moccasins, made noise when you walked.” In the early 1920s, the Converse Shoe Company hired Chuck Taylor away from a basketball team to conduct basketball clinics and in 1923 the *All Star Chuck Taylor* Converse rubber shoe was introduced. The Bata Shoe Company marketed a similar shoe internationally.

“Jellies,” the translucent plastic (polyvinyl chloride) shoes, were developed due to leather shortages resulting from World War II. They were created by Mr. Jean Dauphant and family at Plastic-Auvergne and are a continuing international success.

The twentieth century increasingly saw shoe manufacturers appealing directly to children through such techniques as tie-ins with television shows such as *Howdy Doody*, *The Lone Ranger*, various cartoons, and *Sesame Street*. The 1980s saw catalog and department store giant Sears, Roebuck and Co. introduce Grranimals, a line of children’s clothing with accompanying footwear that had strategically placed emblems that aided children in creating coordinated outfits on their own.

On the basis of an examination of recent children’s footwear styles, it could be argued that after thousands of years of the subjugation of children to the vagaries of adult shoe styling, it is now children’s shoes that are influencing adult shoes, particularly in the area of slip-ons and Velcro-closures. The history of children’s shoes is a relatively underdeveloped field that offers many possibilities for fruitful further study.

See also **Shoes; Shoes, Men’s; Shoes, Women’s; Sneakers.**

#### BIBLIOGRAPHY

- Butterworth, Jeffrey A. “Gentle Souls: Shoemakers in Seventeenth Century Boston.” Master’s thesis, University of Rhode Island, 1998.
- Cunnington, Phillis, and Catherine Lucas. *Costume for Births, Marriages and Deaths*. London: Adam and Charles Black, 1972.
- Grew, Francis, and Margrethe De Neergaard. *Shoes and Pattens*. London: Museum of London, 1988, 2001.
- A Lady. *The Workwoman’s Guide*. Reprint. Guilford, Conn.: Opus Publications, 1986. Originally published in 1838.
- Neils, Jennifer, and John H. Oakley. *Coming of Age in Ancient Greece: Images of Childhood from the Classical Past*. New Haven, Conn.: Yale University Press, 2003.

Jeffrey Butterworth

**SHOES, MEN’S** In the medieval period new shoes were available only to a tiny elite of aristocrats and wealthy merchants. However, it appears that in Britain almost all of the poor wore some kind of footwear, which was made possible through the widespread practice of re-



**A pair of black leather winkle-picker shoes.** Developed as a men’s shoe style in the 1950s, the pointed toes of the winkle-pickers led to their name being derived from a sharply-pointed tool. COLLECTION: POWERHOUSE MUSEUM, SYDNEY, AUSTRALIA. PHOTO: SUE STAFFORD. REPRODUCED BY PERMISSION.

making and repairing old shoes. Medieval shoes were made from leather, silk, and other cloths and up to the end of the sixteenth century, all men’s footwear tended to be flat. The most extreme style of the fourteenth and fifteenth centuries was the “poulaine,” or “pike,” which featured extremely pointed toes, sometimes up to four inches (10 centimeters) in length.

Shoes with an arched sole and heel emerged at the end of the sixteenth century, a novelty that was to become a predominant feature of men’s shoes in the seventeenth and eighteenth centuries. During the reign of James I (1603–1625), masculine court fashions became particularly flamboyant and stockings and shoes became a key focus of attention. The shoes of the wealthy began to be decorated with large bows, rosettes, or “roses.” These styles were superseded in the reign of Charles I (1625–1649), when political instability and war in Britain and Europe encouraged the popularity of military-inspired, knee-high, leather boots. These were fashionable from the 1620s to the 1690s and despite their practical origins as riding wear, they were often elegant and decorative.



"A sewing machine for leather was in use by the 1850s ... and by the end of the century most shoes were made in large factories. The personal relationship between shoemaker and wearer disappeared except at the most expensive end of the market" (Mitchell, p. 34).

### Early Modern Period

The rise of France as an international fashion center under Louis XIV (1643–1715) promoted the popularity of French court styles. Shoes were adorned with decorative buckles, a style that remained highly fashionable until the 1780s. Buckles were bought as separate items and by the late eighteenth century they were available for all tastes and pockets, from sparkling precious stones for the wealthy, to plain steel, brass, and pinchbeck for the lower orders.

New shoes became more accessible to the middle classes in the eighteenth century, owing to relative increases in incomes and new manufacturing methods. The development of large workshops, which produced ready-made shoes by hand helped to make shoes more affordable.

### Modernity and Men's Footwear

The Enlightenment and the French Revolution (1789–1799) stimulated tastes for the plain, English, country mode of dress, which dominated international fashion from the 1780s. An important element of this style was the jockey or top boot, which featured a top of lighter colored leather. Popular men's wear styles of the early nineteenth century included laced-up walking shoes, flat leather evening pumps, and boots of various styles including top boots, Wellington, Hessian, and Blucher boots. The latter three illustrate the tendency for boot styles of the era to be named after significant military figures or developments.

By the mid-nineteenth century, ankle boots, such as the Balmoral, became the most common type of footwear for men and popular shoe styles included the Oxford and the Derby. These shoe types along with the brogue were widely worn in the twentieth century and are still common in the twenty-first century.

Shoe production was increasingly mechanized in the mid-nineteenth century and by 1900 most people wore shoes made in factories and sold by shoe retailers, rather than patronizing shoemakers. By the 1890s, relative increases in wealth, increased participation in sport and leisure activities such as tennis, golf, and cycling, and improvements in mass-manufacturing techniques led to middle-class consumption of an increasingly diverse

range of styles, suitable for various contexts and activities. Despite these transformations in the production and consumption of shoes, leading bespoke shoemakers from this era such as John Lobb Ltd., London, and New & Lingwood, London, have survived into the twenty-first century.

### Men's Shoes Post-1945

The predominant features of men's shoes in the post-1945 period have been an expanding diversity of styles and price levels and a more rapid turnover of fashionable designs. The manufacture of ready-made shoes became global after 1945, with low-cost production now concentrated in Asian countries and more exclusive shoes being made in Italy. From the 1950s the rise of youth fashion generated a greater degree of experimentation in men's footwear, with the emergence of designs such as brothel creepers, winklepickers, Chelsea boots, and Doctor Martens boots.

Since the mid-1970s, the trainer or sneaker has come to be ubiquitous footwear for men of all ages and tastes. This has partly been owing to a general move toward informality in male appearances, but is also linked to the influence of black street fashion and the aggressive marketing efforts of global sportswear companies like Nike, Puma, and Adidas.

The 1970s saw the appropriation of men's shoe styles such as Dr. Martens by women, a trend that was linked to the influence of feminist ideas and the punk subculture. Unisex or androgynous footwear has continued as a feature of mainstream dress in the early twenty-first century. However, despite these developments, there remain significant differences between men's and women's shoes. High heels are still seen as exclusively feminine and men's businesswear remains focused around variations on the Derby and Oxford styles.

*See also* **Boots; Inuit and Arctic Footwear; Sandals; Shoemaking; Shoes; Shoes, Women's; Sneakers; Sport Shoes.**

### BIBLIOGRAPHY

- Baynes, Ken, and Kate Baynes. *The Shoe Show: British Shoes since 1790*. London: The Crafts Council, 1979.
- Boydell, Christine. "The Training Shoe: 'Pump Up the Power.'" In *The Gendered Object*. Edited by Pat Kirham. Manchester, U.K.: Manchester University Press, 1996.
- Cohn, Nik. *Today There Are No Gentlemen*. London: Weidenfeld and Nicolson, 1971.
- de la Haye, Amy. *The Cutting Edge: 50 Years of British Fashion 1947–1997*. London: V & A Publications, 1996.
- Mitchell, Louise. *Stepping Out: Three Centuries of Shoes*. Sydney: Powerhouse Publishing, 1997.
- Woolley, Linda, and Lucy Pratt. *Shoes*. London: V & A Publications, 1999.

Fiona Anderson



**SHOES, WOMEN'S** In cultures where bare feet are customary or only simple sandals are worn, little interest exists in the female foot as a sensual appendage. However, hidden away in tight, decorative shoes and boots, the female foot has been revered as a powerful sexual stimulus in many cultures. Smaller and narrower than a man's foot, the attributes of a woman's comparatively delicate foot has been appreciated and accentuated throughout much of history. This is most apparent in the extreme practice of Chinese foot binding.

For a thousand years in China it was considered refined and sexually attractive for a woman to have bound feet. Outside of weekly washing and perfuming, the feet were kept bound tightly at all times. Several attempts over the years to outlaw the practice by the ruling Manchurians failed and even the Republic made an attempt at stopping the tradition in 1912 when it came to power. The tradition slowly discontinued over time, being finally eliminated in 1949 under the communists. This is by far the most extreme example of sexual differentiation in footwear history. Most cultures cover the female foot differently than the male foot, but in a far less dramatic manner.

Amongst the traditional Inuit of central Northern Canada inlaid furred sealskin boots are designed with vertical patterns for men and horizontal patterns for women. In some cultures it is a matter of who wears the boots. Native Southwestern American Zuni women wear tall white skin boots, while the men wear shorter boots or shoes. Greenlander women's traditional costume includes thigh-high blood-red sealskin boots with decorative appliqués while men wear shorter, darker colored boots.

### Fashion Footwear to 1600

In Western culture, it is women who generally wear more architecturally significant or decorous foot coverings. With few exceptions, until the Renaissance, women's footwear was generally less interesting for the simple reason that it was less visible under the longer garments worn, and it was men who were the peacocks in the footwear department.

In ancient Egypt, Greece, and Rome, women wore sandals consisting of fewer straps and less decoration than men's sandals, baring more toe cleavage. During the late Roman or Byzantine Empire, Christianity brought about radical change from the ancient classical ways. Christian morality considered it sinful to expose the body. St. Clement of Alexandria, in the third century, was already preaching humility for women, commanding them not to bare their toes. Byzantine footwear was designed to cover the feet, and shoes replaced sandals. Roman-style sandals remained the privilege of high-ranking church officials, and abundant decoration was seen as too worldly for the people to wear, appropriate only for the Pope and other prelates.

The largest threat to the Byzantine Empire came with the expansion of Islam that, by 750, had grown to

include most of the old Roman territory including Egypt and its Christian Copt population. By the eighth century, Coptic steles (gravestones) depict the deceased wearing shoes and mules, sometimes decorated with gilded figures and etched linear designs, often in sacred imagery. The shoe had evolved to include a pointed toe and peaked throat and was often made of red kid. Called *mulleus* in Latin, referring to the red color, it is from this connection that the modern term "mule"—for a backless shoe—originates. This style can still be found in parts of the Middle and Far East.

Christianity reinforced the alliance of what was once Rome's domain. During the Carolingian age of Charlemagne (768–814) a close relationship between the various kings and the pope secured the Church in much of Europe unifying the European kingdoms.

Europe began to emerge from the Dark Ages in about 1000 C.E. Christian Europe was uniting into nations, headed by monarchies. These European states began crusades into the Holy Land, bringing themselves into contact with Islamic thought and products. The crusaders brought back silk, embroidery, and the button, whetting the appetites of nobles who craved finery and novelty. The textile arts flourished with the production of quality weavings, embroideries, leather goods, and felts. At the same time, merchants became wealthy importing and exporting these goods, making enough money to dress like nobles. Fashion was now a commodity that expressed the status of its wearer. Elitism could be expressed through a sumptuous display of fashion excess.

The first footwear fashion excess was the elongated pointed toe, said to have originated in the late 1100s. The style was popular in the late 1100s but subsided from fashion, and when reintroduced from Poland in the early 1300s it had become known as a *poulaine* or *crakow*, reflecting its supposed Polish origin.

Expensive materials and excessive styles were royalty's way of staying ahead of the moneyed bourgeoisie. If the sheer cost of dressing well did not create enough of a gap between the well-to-do and the have-nots, then edicts were placed upon materials, styles, and decorations restricting their use to persons of appropriate status. The church also set restrictions against obscene or excessive fashions. Together, these governing bodies attempted to keep the classes in their place, making each identifiable by their dress.

In England, in 1363, Edward III proclaimed a sumptuary law that limited the length of the toe to the wearer's income and social standing; commoners earning less than 40 *livres* per year were forbidden the use of long toes; those who made more than 40 *livres* annually could wear a toe no longer than six inches; a gentleman no more than twelve inches; a nobleman no more than 24 inches; and a prince was unlimited in the length he chose.

Northern Europe continued to don the style until the end of the fifteenth century, even though Italy, southern France, and Spain essentially stopped wearing the protrusive toe, choosing instead to have less pointed footwear made of the finest kid leather or silk.

When length finally became old fashioned, width became the next fashion excess. Popular in the English Tudor court and other northern European states of the sixteenth century, shoes with widths that extended well beyond the foot were known variously as the *hornbill*, *cow-mouth*, or *bearpaw*. This new dimension suffered the same excesses as the long toe. Under England's Queen Mary, another sumptuary law was passed, and although its wording is lost, it can be assumed that the width of the toe was similarly limited according to social status and wealth of its wearer.

The last dimension was now to be explored—height. The ancient Greeks first put platform sandals on the feet of their actors to give them distinction, suggesting the performer was playing an important person. Ancient Greek women adopted cork-soled versions, called *Cothurnus*. Fifteenth-century aristocratic Venetian women donned stilted mules or shoes, called *chopines*, to reflect their high social status. Fashioned in velvet with tack-work or white alum tanned kid with punch-work brogueing, *chopines* not only added height, but also décor to the silhouette. Although called “depraved” and “disolute” by the church, the style traveled across Europe where by 1600 even Shakespeare wrote in *Hamlet* “Your Ladyship is nearer to heaven than when I saw you last by the altitude of a *chopine*.” Maidservants were required to steady the wearers of some of the tallest *chopines* that could reach a height of up to 39 inches (one meter). *Chopines* fell from fashion when prostitutes donned them, ruining their status for women of breeding. Heels, introduced in the 1590s, eventually displaced the platform mules, although some extant examples of *chopines* date as late as 1620.

### Seventeenth and Eighteenth Centuries

When heels were first added to shoes in the 1590s they were only about an inch in height. Women's heels took on greater elevations during the reign of Louis XIV (1643–1715) in France. Heels towered two to three inches, although “well-heeled” women's skirts made their shoes virtually invisible. The heel expressed the status of the wearer as they were quite literally at a higher level than the hordes of common folk. Under Louis XIV, red heels were worn strictly at court. Although this law existed only in France, by restriction the color came to represent the power and status of the aristocratic elite across Europe.

Three different heel types developed in Europe during the eighteenth century. The Italian heel was tall and spiked, like a stiletto. The French heel was of mid-height and curvaceous and later became known as the Louis heel; and the English heel was thicker and generally low to mid-

height. Fashionable continental European women were more inclined to be at court or at home in an urban setting, so their heels could generally be more delicate, while English women of breeding tended to live at their country estates for most of the year, so a thicker heel was necessary for the more natural terrain they traversed.

When the skirts of French gowns inched toward the ankles in the mid-eighteenth century, suddenly there seemed to be an erotic interest in the high-heeled shoe, as it made the foot appear smaller and narrower, and gave the ankle a delicate shape. In the meantime, due to practicality, men were now solidly planted on the ground with heels of less than an inch. It was appropriate for a gentleman to walk upon a muddy, cobbled street that required a low-heeled shoe or boot. A lady of quality, however, did not walk the streets and likely traveled by coach or other means, so a high heel was appropriate for most occasions she would encounter.

Throughout the seventeenth and eighteenth centuries an increasing fondness for luxurious fabrics and decorative trimmings ensued. European-made damask and brocaded silks had been produced in Italy and France until the emigration of Protestant French Huguenots in the last quarter of the seventeenth century. They brought with them the knowledge of silk production when they resettled throughout Protestant Europe, from Spitalfields, England, to Krefeld, Germany. The costly development of this new industry, however, kept domestically produced silks at a higher price than imported Chinese silks.

Chinese silks were usually brocaded patterns of abstract geometric designs, made specifically for the western market. To support the development of a domestic silk industry, England banned the wearing of Chinese silk in 1699; other countries proclaimed similar edicts. Silks produced in Europe followed the Oriental taste of abstract patterns and became known as “bizarres,” remaining in fashion until the 1730s when tastes changed and grand floral designs came into vogue.

The decoration of shoes used many techniques: silk embroidery, applied cord *passementerie*, and silver and gold thread embroidery that was made by professional male embroiderers who belonged to embroidery guilds.

Originally, buckles came into fashion because of their utility. Samuel Pepys refers to putting on buckles for the first time in 1660. By the end of the seventeenth century, buckles overtook the standard of ribbon laces. Both men and women increasingly suffered from buckle mania throughout the eighteenth century. Buckles grew in size and became more elaborate, set with showy paste and semiprecious stones. Men's buckles were larger but both sexes displayed their shoe jewelry during a bow and curtsy with extended foot—the appropriate method of introduction of the day.

By the end of the eighteenth century mercantile and industrial wealth had created a strong, affluent, educated,



**Illustration of woman wearing chopines.** In the fifteenth century, aristocratic Venetian women began wearing platform shoes as a symbol of status, and the style quickly spread across Europe. THE GRANGER COLLECTION LTD. REPRODUCED BY PERMISSION.

yet politically under-represented middle class who were set between an ever-deepening rift of the noble elite and the working poor. The American and French revolutions exploded out of this imbalance, and, in the end, demographics won. The middle classes rose to power and would become the brokers of taste.

In the early months of the French Revolution, the French National Assembly demanded that all deputies give up their valuable shoe buckles for the benefit of the treasury. The legislative session of 22 November 1789 opened with le Marechal de Maille making the patriotic gift of his gold buckles.

### **The Nineteenth Century**

Following the French Revolution, plain leather footwear became the mode. Durable and affordable, it was considered more democratic than the fussily embroidered and expensive silk shoes previously preferred by the elite.

Heels also fell from use after the French Revolution, in keeping with the new democratic philosophy that all people are born equal. The new French and American republics looked to classical models of democracy for inspiration and excavations at Pompeii and from Napoleon's military campaigns in Egypt brought renewed interest in the ancient world and provided inspiration for neoclassical designs.

Women's fashion took on the silhouette of a Greek column. Neutrals of white and tan were complimented by dark tones of the classical world: Pompeian red, crocodile green, and rich gold. The sandal was revived during the neoclassical period, although not with great success, especially in the colder northern European climates where instead, shoes were fashioned with cutouts lined with colored underlays or painted with stripes to emulate sandals. During the Napoleonic wars an inconsistent fashion image existed. In shoes, the use of heels



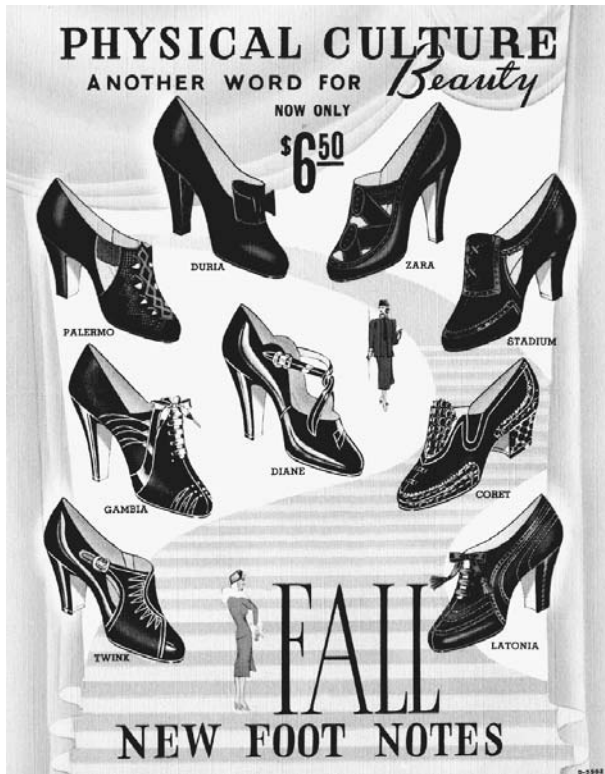

**Physical Culture women's shoes advertisement, 1938.** By the 1930s, the color, shape, and decoration of shoes had expanded to offer numerous options for fashionable women. © LAKE COUNTY MUSEUM/CORBIS. REPRODUCED BY PERMISSION.

and the shapes of toes varied, with no one style predominating. The square toe, introduced as early as the 1790s, did not become the main style until the late 1820s but would remain so for the next half century.

As factories disfigured the horizon, many longed for the picturesque qualities of an unspoiled landscape. A naturalism movement brought long country promenades into fashion; ladies began to wear "spatterdashes," leggings adapted from men's military dress that protected stockings from spatters and dashes of mud. Walking became a fad called "pedestrianism" and a prescribed activity for women. Boots were worn for this activity as a sensible alternative to fashion shoes. Ankle boots, referred to as demi-boots or half boots, found international appeal in this period.

By the time Queen Victoria ascended the throne in 1837 a sentimental, romanticized movement had swept popular thought. Women became expressions of virtue and femininity, their conservative costume and demure decorum reflected conscious gentility. Fine slippers of kid and silk were made in great quantities in Paris and exported around the world. Soles, which had been made without left or right definition for more than 200 years, were exceptionally narrow now and the delicate uppers

tended not to last long as they were pulled under the sole at the ball of the foot, deteriorating with one wearing. Colored footwear found favor during the 1830s with ankle-length skirts, but fell from use for the next two decades. The long, full skirts of the mid-nineteenth century hid the feet from view, with perhaps the occasional peep at a vamp when the woman walked or waltzed across a floor. By the mid-1850s, black or white footwear was deemed by fashion delineators to be the most elegant and tasteful choice, a standard that would last for many years.

However, after the mid-1850s, with the introduction of wire frame "crinoline" skirt supports, skirts tended to tip and swing, exposing the foot and ankle. This brought about interest in the decoration of shoe vamps. Machine chain-stitched designs with colorful silk underlays, dubbed "chameleons," became fashionable for home and evening wear. For daytime, however, boots became modest essentials underneath the wire-frame supported skirts. Side-laced boots called "Adelades" in England, after William IV's consort, were made for most outdoor occasions until improvements in the elasticity of rubber resulted in the development of elastic thread which, woven into webbing, was used for ankle-boot gussets. Elastic-sided boots were referred to as "Garibaldi" boots in Europe after the Italian statesman who united Italy during the 1860s, and as "Congress" boots in the United States after the American Congress. Front-laced boots came back into fashion by 1860. Called "Balmorals," after Queen Victoria's Scottish home, the style was deemed suitable for informal daywear and sporting occasions at first, but by the 1870s had become the more common closure of all boots. Button boots were introduced in the 1850s, but were generally not favored until the 1880s when their tight fit and elegant closure flattered the slim ankle and foot more than laced styles.

Heels were re-introduced on ladies' footwear during the late 1850s, but did not find universal appeal until the late 1870s. Historicism was an important movement of the mid-nineteenth century; Rococo and Baroque styling was evident on shoes in the 1860s with a return to buckles and bows. Large, multiple loop bows were called "Fenelon," after the seventeenth-century French writer. Mules, too, came back into fashion as part of the historical revival of the *ancien regime*.

Exoticism was another important movement of the nineteenth century. Via the Crimean war, Turkish embroideries were exported for the production of shoe uppers in the late 1850s and when Japan opened its doors to foreign trade in 1867, a taste for all-things Oriental made a strong comeback. Chinese embroidered silks or European embroidered silks in the taste of Chinese and Japanese textiles were in fashion and a Japanese-influenced palette of colors resulted in brown leather footwear coming into vogue, which would become a fashion staple.

By the late 1880s the square toe had finally fallen from fashion, replaced by rounded and even almond-

shaped toes and all shoes were now being made with right and left sole definitions. Business began to decline for hand shoemakers as mass manufacturers standardized sizes and provided widths for customer fit. Improvements in American manufacturing methods and machinery, as well as cheaper production costs positioned the Americans as the leading footwear manufacturers for the next fifty years.

### The Twentieth Century

Black, brown, and white footwear predominated until the 1920s. Colored footwear was made almost entirely for evening dress, as it was seen as inappropriately gaudy for street or daywear. After the start of World War I in 1914, hemlines began a steady climb up the leg, so that by armistice the sensuous curves of the instep and ankle were exposed. The climbing hemline made the gap between the top of the boot and bottom of the hemline an unsightly distraction. The boot was generally abandoned from fashion, although a "Cossack" boot, or pull-on style was introduced and found some success in the late 1920s.

The impact of the shoe on the complete silhouette now had to be calculated to find a complimentary style. During the 1920s, short and curvy heels grew taller and straighter, which tightened the calf muscle, slimming the appearance of the ankle and foreshortening the foot making it appear smaller. Even the vamp was cut lower to expose more of the instep.

By the 1930s, shoemakers had become shoe designers. Color, shape, and decoration literally exploded at the feet of fashion. A wide variety of spectators, oxfords, pumps, sandals, brogues, and other styles filled the shoe stores. Salvatore Ferragamo revived the *chopine* in 1937, using cork to create platform soles. Internationally, the style found limited success, but with the beginning of World War II (1939–1945) the style grew in popularity. The war resulted in a shortage of leather for civilian footwear; thick wood or cork soles and substitute leather uppers made of raffia, hemp, or textile substituted. In the United States, where rationing was less severe than in Europe, platform shoes were more often made of leather, but women were rationed to two pairs of shoes per year.

The tall tapered heel remained in fashion from the late 1920s to the mid-1950s with only subtle changes in form until the Italian heel, renamed the "stiletto," became the fashion in the late 1950s. Tall and very slender with a metal core, the heel was named after the weapon for a reason. The narrow heel created pressure of hundreds of pounds per square inch with every step, pock-marking linoleum and wooden floors. Visitors to the Louvre were required to don plastic heel caps to protect the ancient floors. The stiletto heel, paired with a sharp pointed toe, was the most aesthetically complimentary shoe style ever designed. The pointed toe visually narrowed the foot and the high heel tightened the calf muscle, slimming the ankle. Medically, it was the worst

combination ever created. Many women turned their ankles on the metal spikes, catching the tips in manholes, subway grates, or even cracks in the sidewalk; the high heel forced the foot forward into the pointed toe, which curtailed the toes, causing bunions and hammertoes.

In reaction, a low-heeled, square boot came back into fashion in the mid-1960s. Paired with miniskirts, the boot highlighted the leg and gave a youthful élan to the fashions of the day. Boots came on the fashion scene at the same time as the popular "go-go" dances of the day and quickly became known as go-go boots—usually white ankle boots.

The early 1970s saw the return of the platform that accomplished two feats at once. Women's liberation was reflected in the elevated soles that put women on an equal footing to men. At the same time, platforms were complimentary to the length of the leg, made apparent in hot pants, miniskirts, and long-legged pants.

Since the early 1970s fashion footwear has been eclipsed by the sports-shoe phenomenon. More runners, joggers, cross-trainers, and basketball shoes have been sold than high-fashion shoes on an annual basis. Scientific advances in fit and comfort has been paired with conscious design and celebrity marketing, creating a mad frenzy for every new design released. Fashion experts may scoff at sports shoes as fashion, but many designers have paid homage to the style in upscale versions over the past thirty years.

High-fashion footwear of the last quarter of the twentieth century consisted almost entirely of revivals. The stiletto-heeled, pointed-toe shoe of the late 1950s and early 1960s was the mainstream high-fashion style of the late 1980s and early 1990s. Every time the platform shoe has come back into fashion it has been heavily inspired by its previous incarnation. The platform shoes of the 1990s were many times perfect re-creations of their 1970s predecessors, to the point where it was nearly impossible to tell the difference between the retro and the true vintage versions.

Subtle tweaking of heel shapes, toe shapes, decorations, colors, and materials, and the combinations in which they are used are the only elements that define the past thirty years of fashion footwear from previous styles. Multiplicity is key to the fashion footwear of the early 2000s: stilettos, platforms, chunky heels, low heels, pointed toes, square toes, boots, shoes, and ballerina flats. Virtually all styles are available at the same time, and all of them are at the height of fashion.

See also **Boots; Footbinding; High Heels; Inuit and Arctic Dress; Sandals; Shoes; Shoes, Men's; Sneakers; Sports Shoes.**

#### BIBLIOGRAPHY

Bondi, Federico, and Giovanni Mariacher. *If the Shoe Fits*. Venice, Italy: Cavallino Venezia, 1983.

- Durian-Ress, Saskia. *Schube: vom späten Mittelalter bis zur Gegenwart Hirmer*. Munich: Verlag, 1991.
- Ferragamo, Salvatore. *The Art of the Shoe, 1927–1960*. Florence, Italy: Centro Di, 1992.
- Rexford, Nancy E. *Women's Shoes in America, 1795–1930*. Kent, Ohio: Kent State University Press, 2000.
- Swann, June. *Shoes*. London: B.T. Batsford, Ltd., 1982.
- . *Shoemaking*. Shire Album 155. Jersey City, N.J.: Parkwest Publications, 1986.
- Walford, Jonathan. *The Gentle Step*. Toronto: Bata Shoe Museum, 1994.

*Jonathan Walford*

**SHOPPING** Early histories of shopping comprised celebratory histories of individual shops, and chronological accounts of retail progress (Adburgham). Recent studies have come from social, economic, and increasingly cultural history. They balance empirical and focused studies of shops and shopping with the more thematic agenda offered by consumption studies. A significant proportion of studies is devoted to shopping for clothes and related fashionable goods. This kind of shopping was associated with a particular set of shopping and retail practices.

The popularity of shopping as a subject for research is linked to the meteoric rise of the topic of consumption within a multitude of different disciplines, including history, sociology, anthropology, cultural studies, psychology, and geography. This phenomenon has been connected to an increasing dissatisfaction with Marxist production-led explanations for historical trends. The way people shop has since been identified as a defining characteristic of historical and contemporary societies (Miller et al.). Early work in the field connected the birth of modern consumer culture with the new availability of mass-produced goods in the late eighteenth century (McKendrick et al.). Subsequent studies have given more significance to changes in shopping practices. The arrival of the department store in the late nineteenth century has been seen as a marker of modern consumer cultures (Bowlby, Rappaport), and postwar supermarkets and malls have been closely tied to understandings of contemporary consumer society (Bowlby, Campbell in Miller).

### The Shopper

The identification and definition of consumer identities has been an increasingly central component of shopping studies. Drawing on the semiotic theories of postmodernists such as Jean Baudrillard, consumer identities, and shopping types have often been appropriated for source material by a range of disciplines. These figures have been seen as the embodiment of contemporary attitudes to, and anxieties about, consumption, gender, class, ethnicity, modernity, and the urbanites. This approach has been criticized for obscuring the meaning of shopping itself

within these identities, as Miller et al. express, “the shopper ... nearly always figures as a sign for something else.” Within this work, shopping has been shown to be an important part of identity construction and performance, leading to the suggestion that within modern and post-modern consumer society, the self *was* the sum of consumption practices and goods bought. This idea of self-construction through shopping has been consistently promoted through store advertising, women’s magazines, and other institutions of consumer culture. However, more specific studies have allowed shopping cultures and consumer identity to be mutually constitutive, ascribing more agency to the individual shopper, and the ability to negotiate different identities.

There has been a particular emphasis on identity within studies of Victorian consumption. For example, the Victorian London’s shopping district has been revealed as home to newly confident female shoppers who used shopping to stake a claim to the city (Rappaport). This focus signals the advent of modern consumer culture, in which shopping was recognized as a meaningful practice and the consumer the key protagonist. From this point on, shops can be seen to sell “image” in addition to actual commodities, an image that was bound up with modern consumer identities. During the twentieth century, the centrality of the shopper within retail theory and its histories grew, reflecting a heightened understanding of how consumer psychology could be applied to marketing. By the late twentieth century, the consumer was acknowledged as a primary economic and cultural force in society.

The study of the female shopper has dominated the field. This relates to the conceptualization of shopping as a strongly gendered practice by contemporaries as well as by many subsequent theorists. It has been presented as an essential component of the female domestic role, interpreted as a masculine seduction of the feminine through strategies of temptation and spectacle, and more recently as a more empowering, but essentially feminine, means of engaging with urban life. Bowlby summarizes this position: “The history of shopping is largely a history of women, who have overwhelmingly been the principal shoppers both in reality and in the multifarious representations of shopping” (Bowlby, p. 7). This gender imbalance has begun to be seriously addressed in the early twenty-first century. For example, Breward has identified significant groups of male shoppers in Victorian and Edwardian London, for whom shopping for clothes was an essential component of their fashionable urban identities.

Past studies of the shopper have often overlooked the centrality of the fashionable commodities themselves, which newer work has sought to address. It is the focus of consumers’ attention on the goods in the window, and on the activity of shopping, that distinguishes them from other actors in the urban scene; the *flâneur*, the tourist, the prostitute. This approach allows an understanding of the role of shopping within the identity of clothes. It



acknowledges the significance of garments' nature as "searched for" and "bought."

### A Typography of Shops

Specificity of time and place are important to an understanding of shopping. Particular retail formats, each with their characteristic architecture, planning, and shopping practices, have been considered emblematic of social trends within studies of consumption. Miller et al. relate how during the late 1980s and early 1990s the story of modern consumption coincided with a particular genealogy of the shop; "an accepted natural history of consumption took shape which, identifying consumption as a key characteristic of modernity, described an arc from the arcades and department stores of Paris through to the shopping malls of the United States."

Of course, shopping for clothes did not begin with the birth of modern consumer cultures. There is an older tradition of shopping, which includes drapers, tailors, and markets. The beginnings of a new approach to shop design and shopping, which emphasized luxury, spectacle, and leisure, have been identified in the seventeenth- and eighteenth-century shopping gallery, for example London's Westminster Hall, and the nineteenth-century arcade, such as the Burlington Arcade adjoining Piccadilly (Walsh in Benson and Ugolini).

The huge department stores of the late nineteenth century exploited these characteristics to the full. Drawing on the model of the Parisian Bon Marché, they styled themselves as "universal providers" and offered a range of additional services from hairdressing to libraries, but drapery and ready-made garments formed a central part of their trade. The department store has been associated with the advent of modern consumer cultures, the democratization of "luxury" consumer goods, and the prominence of display. It has also been linked to the broader themes of the growth of the middle classes, urbanization, and shifts in gender definitions (Bowby, Rappaport).

The first half of the twentieth century witnessed the development of "multiples" or chain stores, which catered especially to the growing group of lower-middle-class consumers. In Britain, Marks & Spencer, C&A, and the Co-op were especially important for women's and children's wear, while multiple tailors, such as Montague Burton, targeted men (Winship in Jackson et al.). There were also more exclusive multiples such as Austin Reed menswear and Russell and Bromley shoes. The shops constituted clearly identifiable brands, through their architecture, interior design, advertising, as well as merchandise. While frequently establishing a flagship on the principal urban thoroughfares, multiples have largely been associated with the suburban and provincial high street.

The story of postwar shopping has been dominated by the development of the "shopping center" and mall, burgeoning in the interwar United States, and spreading to Europe during the 1960s (Longstreth). They have



**Burlington Arcade, London, England.** A doorman stands in London's Burlington Arcade, which was founded in the nineteenth century and emphasized luxury, spectacle, and leisure. © BO ZAUNDRES/CORBIS. REPRODUCED BY PERMISSION.

been studied intensively, and have often been interpreted as an articulation of postmodern society (Campbell in Miller). The new format was purpose-built and often privately regulated, usually enveloping both shops and a shopping street for pedestrians within a single building. Some have been located within city and town centers, replicating some of the characteristics of the department store. But they have been mainly associated with the urban fringe, dependent for business on increased levels of car ownership. A typical example in the United Kingdom is Meadow Hall, near Sheffield. Although very successful, these new shopping environments did not destroy the cultural and economic importance of the traditional high street.

An associated late twentieth-century development is the retail park: a series of shopping warehouses located out of town. This period additionally saw the expansion of the big supermarkets into clothing. Their marketing has emphasized value, with the controversial provision of cut-price designer jeans, and attempts have been made to

secure the services of established designers, for example George at Asda in the United Kingdom. This era has also been characterized by the internationalization of retailing. On one hand, powerful controlling interests such as Wal-Mart have developed as a result of construction of new stores. On the other, multiples such as the Gap have opened outlets in shopping thoroughfares throughout the world.

### Other Ways of Shopping

Alongside these sites of consumption, secondhand clothing continued to be an important part of shopping practices. Its retail venues shifted format and location within shopping networks over time, and were historically associated with a succession of different immigrant communities, working from street markets. From the latter part of the twentieth century, buying secondhand has flourished within the charity shop, retro-clothing specialists, market stalls, and flea markets.

However, shopping has not exclusively been tied to physically located retail sites. Mail order allowed shopping to take place from the home. Sears, Roebuck and Co. spearheaded mail order in the United States, with companies such as Freemans and Kays important in the United Kingdom.

It proved consistently popular throughout the nineteenth and twentieth centuries, often linked to credit schemes and to companies with associated retail outlets, such as the United Kingdom's "Next Directory." From the end of the twentieth century, the potential of mail-order shopping expanded exponentially with the arrival of Internet shopping, potentially posing a more serious challenge to the future viability of the traditional shop, although retail clothing stores has been less seriously affected than other sectors.

There has been an unwillingness to study shopping cultures, which were not essentially novel, however, a more integrated understanding of shopping can be gained by studying the established and declining models alongside new ones. This approach better reflects the landscape of different shops, configured in particular ways within a single main street, a shopping route, or an individual's shopping trip. It also relates more closely to the clothing bought by shoppers; within a single wardrobe a chain-store shirt hangs next to a secondhand jacket quite unproblematically, although their owner remains aware of the provenance of each.

*See also* **Boutique; Department Store; Mannequins; Window Displays.**

### BIBLIOGRAPHY

- Adburgham, Alison. *Shops and Shopping*. London: Allen and Unwin, 1964.
- Benson, John, and Laura Ugolini, eds. *A Nation of Shopkeepers: Five Centuries of British Retailing*. London: I. B. Taurus, 2003.
- Bowlby, Rachel. *Carried Away: The Invention of Modern Shopping*. London: Faber and Faber, 2000.

Breward, Christopher. *The Hidden Consumer: Masculinities, Fashion and City Life, 1860–1914*. Manchester and New York: Manchester University Press, 1999.

Crossick, Geoffrey and Serge Jaumain, eds. *Cathedrals of Consumption: The European Department Store*. Aldershot, U.K.: Ashgate, 1999.

Jackson, Peter, Michelle Lowe, Daniel Miller, and Frank Mort. *Commercial Cultures: Economies, Practices, Spaces*. Oxford and New York: Berg, 2000.

Longstreth, Richard. *City Center to Regional Mall: Architecture, the Automobile, and Retailing in Los Angeles, 1920–1950*. Cambridge, Mass.: MIT, 1997.

McKendrick, N., J. Brewer, and J. H. Plumb. *The Birth of Consumer Society*. London: Europa, 1982.

Miller, Daniel, ed. *Acknowledging Consumption: A Review of New Studies*. London: Routledge, 1995.

Miller, Daniel, et al. *Shopping, Place and Identity*. London: Routledge, 1998.

Poster, Mark, ed. *Jean Baudrillard: Selected Writings*. Oxford: Polity Press, 1988.

Rappaport, Erika. *Shopping for Pleasure: Women and the Making of London's West End*. Princeton, N.J.: Princeton University Press, 2000.

Somake, Ellis E. and Rolf Hellberg. *Shops and Stores Today: Their Design, Planning and Organisation*. London: B. T. Batsford, Ltd., 1956.

*Bronwen Edwards*

**SHROUD** The word "shroud" originated in fourteenth century England to describe the clothing used to dress or wrap a corpse prior to burial, derived from older words *scrud* meaning garment and *scraede*—a piece or strip of fabric. It has since become widely used to refer to garments or coverings specifically made to dress the dead body prior to its final disposal, whether by burial or cremation. Its form generally ranges from a length of cloth to basic loose-fitting purpose-made garments. Although the word shroud can be traced back to a specific place in history, it should not be regarded as the point when burial clothing for the corpse first became used. Contemporary descriptions, archaeological accounts, and artistic depictions occasionally provide evidence of shrouds from earlier periods of history and other cultures, although examples of actual garments rarely survive intact, usually decaying along with the body they were used to dress. An early reference to shrouding can be found in biblical accounts—the New Testament describes Jesus' body wrapped in a linen sheet for burial.

### Early English Shrouds

The early shroud fulfilled the function of containing the decaying corpse, while modestly covering the body. During the eleventh century, ordinary people would have clothed their dead in a loose shirt before wrapping them in a sheet, often colored rather than white, and sometimes swaddled or wound tightly with extra bands of

cloth. The sixteenth-century shroud, also referred to as a winding sheet, was usually a length of linen, which was wound around the body and secured by knotting the fabric at the head and feet. Containment and ease of transporting the shrouded body was important as most people were buried without a coffin at this time. Cunnington and Lucas (1972) and Litten (1991) both provide detailed descriptions of variations of English shrouds before the twentieth century, including alternative grave clothes used for the aristocracy and royalty.

Shrouds increasingly became indicators of social status, reflected in changing designs. A Parliamentary Act was passed in 1678 to enforce burial in woolen shrouds, to promote the ailing English wool trade. A legal document had to be signed at each burial certifying that the corpse had been buried only in wool. The wealthy disregarded this, preferring to pay a fine rather than bury their dead in wool, choosing instead more expensive fabrics and trimmings made from linen, silk, lace, gold, and silver which seemed more appropriate to their social status.

### Funeral Industry

Early shrouds were made specifically for each corpse, often by a family member. The growth of the new undertaking profession from the early eighteenth century onward, coupled with changes in textile and garment manufacture, led to an expanding range of ready-to-wear shrouds in a variety of styles, fabrics, and prices. A typical woolen shroud set at this time might have consisted of a long flannel shirt with a front opening edged in woolen lace or black thread, long sleeves with gathered wrists, a pair of gloves, a cravat, a cap or headdress, and a small square piece of cloth to cover the face.

Victorian shrouds resembled long one-piece nightgowns, white with back opening and long sleeves. The range of fabrics had expanded to include calico, cashmere, linen, muslin, poplin, satin, and silk, trimmed with ruffles, lace, or pin-tucks depending on personal choice and the gender of the corpse.

Designs available increased throughout the twentieth century, also becoming more gender-specific. Within the Western funeral industry, particularly in the United Kingdom and the United States, male shrouds became described as robes, resembling dressing gowns in darker shades of paisley, satin, or suiting. Some give the appearance of a formal suit but are constructed as a one-piece garment. Ladies shrouds have become gowns, frequently styled like nightgowns in pastel shades of satin, taffeta, or printed cotton and trimmed with lace or ruffles. All are full-length, long-sleeved, and open-backed to assist the funeral director in dressing the corpse.

### Religious Ritual

Religious belief frequently provides traditional guidelines for clothing the dead, using specific garments with their own significance. Shrouding the body (*kafan*) plays a cen-



**Funeral effigy of John Donne.** This effigy of John Donne shows the famous poet and priest wrapped in a funeral shroud. The word “shroud” refers to material used to dress a dead body prior to its final disposal. © ANGELO HORNAK/CORBIS. REPRODUCED BY PERMISSION.

tral part in Islamic burial ritual, using plain white lengths of cotton for everyone, regardless of social status or wealth, although variations may occur. After washing the body, it is systematically wrapped in several unstitched pieces of cloth, three for men and five for women. One piece has a hole cut out for the head, resembling a long basic shirt, which covers the whole body.

Shrouds form a similarly crucial part in Jewish burial ritual. Simple white burial garments (*tachrichim*) are used to clothe the body regardless of gender, avoiding ostentation and emphasizing equality after death. Garments include a head covering, shirt, pants, belt, and finally a linen sheet. Fabrics generally used for the garments are white linen, cotton, or muslin and traditionally hand-sewn, although machine-made sets are now available.

### Contemporary Alternatives

Contemporary Western society exhibits a diversity of styles in clothing for the corpse, dependent on age, gender, religious beliefs, and broader cultural background. Anecdotal evidence from within the funeral industry suggests that the use of everyday clothes is increasingly replacing shrouds, especially in the absence of cultural traditions specifying particular garments. The choice of



a final outfit for the deceased becomes a meaningful act for the bereaved family or friends and presents an appropriate last memory, particularly if viewing the body. To be dressed in their own clothes signifies a heightened sense of the individual before death, illustrating aspects of personal taste and character and forming an increasingly important part of personalized funeral ceremonies from the late twentieth century onward.

A growing awareness of the environmental impact of contemporary Western burial and cremation practice is also producing alternative shrouds to those manufactured by the mainstream funeral industry. Simple biodegradable shrouds can be found within the green burial movement made from lengths of silk, wool, unbleached cotton, or linen, large enough to envelop the body.

Despite variations in shrouds both historically and cross-culturally, clothing the corpse remains a significant part of the final rite of passage in all human societies for whom clothing is important during life.

See also **Ceremonial and Festival Costumes; Mourning Dress.**

#### BIBLIOGRAPHY

Cunnington, Phillis, and Catherine Lucas. *Costume for Births, Marriages and Deaths*. London: Adam and Charles Black, 1972.

Litten, Julian. *The English Way of Death*. London: Robert Hale, 1991.

Claire Barratt

**SILK** Among the oldest known textiles, silk was produced in China as early as the mid-third millennium B.C.E. The discovery that silk filament produced by silkworms could be spun into yarns and woven into textiles was later attributed to a legendary Chinese empress who was worshipped as the Patron Diety of Weaving. This account of silk's origins is purely mythical, but it perhaps demonstrates an awareness of both the antiquity of silk production and its importance to Chinese culture. Sericulture, the term used to refer to all aspects of silk production from the raising of silkworms to the spinning of yarn and weaving of cloth, was subject to state control for many centuries, and it was forbidden to export silkworms or reveal the secrets of sericulture outside China. Bolts of silk textiles, produced to standard width and length, were used in ancient China as official trade goods, and were accepted in payment of taxes. Gradually a trade also developed in silk produced for private use and commerce.

The Silk Road, along which silk fabrics were conveyed from China to elsewhere in the ancient world, holds a special place in history. Silk fabrics were sold in such places as Greece and Rome for fabulous prices. The secret of sericulture continued to be carefully protected by the Chinese authorities, but ultimately silk production spread to other places. Rulers of countries beyond China's borders often aspired to marry Chinese

princesses, in part to gain access to their knowledge of sericulture. Silk production was found in Korea as early as 200 B.C.E. and in India and Japan by C.E. 300. (Wild silk was also produced as an indigenous product in India beginning in ancient times.)

According to legend, in C.E. 553, some Nestorian Christian monks returned from China to Byzantium with silkworm eggs and a knowledge of silk production; whether this story is precisely true or not, the silk industry that was transplanted to Western Asia around that time became a major contributor to the wealth of the Byzantine Empire and a source of its leadership in the production of royal and ecclesiastical garments and furnishings. By the eighth century, sericulture had spread to northern Africa, Spain, and Sicily. Spain and Sicily became famous for weaving exquisite silks in what would later become known as jacquard designs. In the early Renaissance, silk production became well established across Italy with Lucca and Florence as major centers. Lyons, France, also became the center of a major silk-producing region. Attempts to create an industry in England struggled, however.

An attempt to establish sericulture in the American colonies in the early to mid-nineteenth century failed, in part because of technical difficulties (such as diseases afflicting silkworms), and partly due to competition from cotton. Cotton was by then a major crop and cotton spinning and weaving were important industries, better suited than silk to the climate and industrial base of the United States. Over time, silk fiber production also failed or became uneconomical everywhere in Europe, leaving China, Japan, India and Thailand as the major sources of silk fiber in the world. Italy and France continue to produce high-quality silk textiles from imported fibers. Silk textiles are also produced in commercial quantities in China, Thailand, India, and some other Asian countries. While silk accounts for only .2 percent of the global textile fiber market, raw silk is valued at about 20 times the unit price of raw cotton. Demand remains strong, and the value of this historically luxury fiber remains high, though the price varies with supply and demand, as with all commodities. Environmental stresses may be a limiting factor in silk production in the future, which would reduce supply and increase price.

#### Sericulture

Like wool, silk is a natural protein fiber. The larvae of the *Bombyx mori* moth, commonly known as silkworms, extrude silk fibers to form their cocoons and simultaneously secrete a gummy coating known as sericin. There are basically two kinds of silk: wild silk and cultivated silk. In both cases, silk is produced when silk moths lay eggs that hatch into caterpillars that eat either mulberry or oak leaves and then spin their cocoons, resulting in silk fibers. Spinning the cocoon takes about a month of the larva's life and yields about a mile of silk fiber, which can be spun into as much as 1,000 yards of silk yarn. Wild silkworms feed on oak leaves. Wild silk is harvested by picking co-

coons left behind when the moths break free. This can result in a short and uneven staple fiber often labeled Tus-sah silk. Raw and Tussah silks are used in fabrics that have a more textured appearance than typical cultivated silk.

The majority of silk comes from a more controlled production process, known as sericulture, that extends over all stages of production, from the moths selected to lay eggs, to identification of the healthiest silkworms, to harvesting and processing of the best quality cocoons. Domestic silkworms are fed mulberry leaves. A selection of moths deemed the best breeding stock are allowed to break through the cocoons and become part of the next cycle of silk production. A majority of larvae are killed with dry heat to prevent the moth from breaking open the cocoons and thus retain the long natural filament characteristic of silk.

After soaking whole, unbroken cocoons in warm water to soften the gummy sericin secretion on the silk, a hand operation known as *reeling* combines the filaments from approximately four cocoons into one uniform filament yarn that is wound onto a reel. Reeled filaments are twisted together in a process known as *throwing*. Outer layers often yield broken yarns that are diverted to production of spun silk, also known as silk noil. If silk is left as raw silk (silk-in-the-gum), the sericin is not removed. However, most cultivated silk is *degummed* through use of a soap solution that dissolves the sericin and produces very smooth, uniform yarns. *Scouring* and *bleaching* may be necessary to get silk white enough for white or pale colors. This causes loss of weight. *Weighting* with metallic salts such as tin may be used to replace the weight. This practice has been found to diminish the strength and durability of silk fabrics and is required to be disclosed on the label. *Dyeing* is done at the yarn or at the fabric level. Some noteworthy aesthetic finishes demonstrate ways silk can be modified. *Sandwashing* silks produces a more faded, casual fabric that is washable. *Sueded silk* is a further processing of washable silks with alkali to pit the surface and raise a slight nap. *Moiré calendaring* creates a watermarked effect on silk taffeta and faille fabrics. The process combines an etched roller, heat and pressure to flatten ribs into the watermarked pattern called *moiré*.

### Characteristics of Silk Textiles

Most silk cloth is made from cultivated and degummed smooth filament and therefore displays the smooth, lustrous qualities associated with the concept “silky.” Silk textiles vary from very soft and fluid satins and crepes to extremely stiff and bouffant taffetas and organzas and sumptuous silk velvet. Interior furnishing textiles often produced in silk include ottoman, bengaline, repp, and tapestry.

Duppioni silk is made from the fibers of twinned cocoons growing together; the resulting thick and thin yarns are used to best advantage in a textured, linen-like



**Silkworm cocoons.** A Japanese girl examines silkworm cocoons with the help of an illuminated table. © HORACE BRISTOL/CORBIS. REPRODUCED BY PERMISSION.

fabric called shantung. Wild silk and silk noil are spun yarns that often have sericin left in the fiber, resulting in fabrics with the appearance of a rough linen and a soft, somewhat gummy feel.

Examined microscopically, cultivated silk fibers have a triangular cross-sectional shape that contributes to a soft, deep, luster and smooth feel typical of silk. Silk has long been considered the ultimate in luxurious feel on the skin. Many synthetic fibers are engineered to emulate the look and feel of silk. Raw silk fibers are more ribbon-like, with a nearly rectangular cross-sectional shape so textiles are not as lustrous or as smooth. With removal of sericin, cultivated silk is almost white while raw and wild silk range from tan to light brown.

As a protein fiber, silk is somewhat warm and very absorbent. Silk can absorb 30 percent of its weight, and dries quickly. Since it is fairly lightweight and typically smooth, silk is often more comfortable than wool for next-to-the-skin apparel or furnishings. Like wool, silk bonds with dyes and supports a wide range of long-lasting colors. In filament form, silk is the strongest natural fiber with greater durability than cotton and fine wools. Silk has a natural elasticity that allows 20 percent elongation. Since silk is subject to water spotting and perspiration stains, silk is often dry-cleaned to avoid potential detergent and bleach damage. Silk resists dirt but can be damaged by perspiration if not cleaned often enough. Silk can also be damaged by prolonged exposure to sunlight. Filament silks wrinkle less than spun silks; both must be ironed with moderate, moist heat to avoid damage. Though resistant to fire, mildew, and moths, silk is eaten by carpet beetles.



**Silk lounging robe.** Actress Anna May Wong in an embroidered Chinese lounging robe made of silk satin. Silk was first cultivated in China and continues to be associated with that country. © CONDÉ NAST ARCHIVE/CORBIS. REPRODUCED BY PERMISSION.

### Silk in Fashion

Silk has historically been a prestige fiber associated with high status. In ancient China it was proverbial that members of the upper classes wore silk, while commoners wore garments of hempen cloth. With the advent of silk exportation, there was such demand in Damascus and Rome that only the very wealthy could afford it. Silk was reserved for special events such as festivals, weddings, and other celebrations, and silk wall hangings and carpet were symbols of great wealth and privilege. In the eighteenth century, the clothing of the rich was often made of silk, and as fashion designers in the nineteenth and twentieth centuries continued to produce garments for a wealthy clientele, fashion tended to perpetuate silk's aura of luxury and prestige. More recently, businesspeople "dressing for success" have considered silk shirts, blouses, dresses, and raw silk suiting to be classic indicators of prestige.

By the 1930s, synthetic fibers were developed to give the look of silk at an affordable price. With the wartime decline of the silk industries in China and Japan, nylon took over most of the market for silk stockings, and "nylons" became commonly available. Acetate was routinely substituted for silk in prom dresses and wedding attire. Polyester, particularly microfiber, has been the most suc-

cessful artificial fiber in emulating the look and sometimes almost the feel of silk at an affordable price.

By the 1990s fashion embraced silk as a fiber that should be available to most people. Silk was reinterpreted as a textile appropriate not only for special events but also for casual, everyday wear. Very important to this expansion in silk was the creation of washable silks with a somewhat faded look and sueded silks that were closer to the aesthetic of cotton. Washable silk was also discovered in home textiles for fabulous sheets, bed coverings, table coverings, and upholstery. Silk even became adopted in sportswear as people discovered that silk underwear was warm and non-itching. Raw silk also became popular for linen-like summer attire. Silk was rediscovered not only for its beautiful fabrics, but for its great comfort and affordable price (as increased production of fiber and improved processing techniques have lowered the cost of silk). Meanwhile, the growth of the craft movement and interest in wearable art has put another kind of focus on silk as a fiber that easily lends itself to creating art that is also apparel.

### Common Silk Textile Uses

Silk is used primarily in apparel and interiors. The range of apparel extends from special occasion costumes to casual T-shirts and silk underwear. Considerable demand for silk for use in wearable art and craft designs has fostered development of catalog and web sourcing for silk, a textile that has become hard to find at the retail level as specialty, high-quality fabric stores have become less common throughout the country. Interior textiles are primarily upholstery, wall hangings, carpets, hand-made rugs, and sometimes wild silk wall coverings treasured for their texture. Silk flowers and plants hold a special place among interior accessories. Recently, there has been a growing demand for silk liners for sleeping bags, silk blankets and sheets. Silk is found in medical products such as dental floss, braces, and surgical sutures, prosthetic arteries, and bandages. Often wigs are made of silk. Silk is also used to make tennis racket strings, fishing lines, parachutes, and hot-air balloons. Remarkably, silk has a number of industrial uses as well, including as crosshairs in optical instruments, as a component of electrical insulation, and even as an ingredients in facial power and cream. Silk was even used in the nose cone of the Concorde jet. Nevertheless, the primary contemporary use for silk is as a fashion textile, continuing a tradition that has lasted for thousands of years.

See also **Fibers; Textiles, Chinese; Wool.**

### BIBLIOGRAPHY

- Collier, Billie J., and Phyllis G. Tortora. *Understanding Textiles*. Upper Saddle River, N.J.: Prentice Hall, 2000.
- Hatch, Kathryn L. *Textile Science*. Minneapolis: West Publishing, 1993.
- Kadolph, Sara J., and Anna L. Langford. *Textiles*. 9th ed. Upper Saddle River, N.J.: Prentice-Hall, 2001.



Parker, Julie. *All about Silk: A Fabric Dictionary and Swatchbook*. Seattle, Wash.: Rain City Publishing, 1991.

Carol J. Salusso

**SIMMEL, GEORG** The German sociologist and philosopher Georg Simmel was born in Berlin on 1 March 1858 to assimilated Jewish parents. Between 1876 and 1881 Simmel studied history and philosophy in Berlin. His doctoral thesis (1881) and post-doctoral dissertation (1885) both dealt with Immanuel Kant. His rhetorical gift proved to be successful with academic and nonacademic audiences alike, and his lectures became social events. In 1890 he married the writer Gertrud Kinel. A year later they had their only son, Hans. In 1894 he published the essay “The Problem of Sociology,” which inaugurated a separate social science. Simmel and his wife were at the center of cultural circles in Berlin; their friends included the poets Rainer Maria Rilke and Stefan George as well as the sculptor Auguste Rodin. In 1903 his essay “The Metropolis and Mental Life” constituted an early study of urban modernity. Latent anti-Semitism, reservations about the academic validity of sociological studies, and envy of Simmel’s social popularity hindered his professional progress in Berlin, and in 1914 he accepted a call to the university in Strasbourg, where he died on 26 September 1918.

Simmel’s discussion of fashion, significant for its early date within academic discourse, its conceptual rigor, as well as its metaphysical breadth are defined by his simultaneous adherence to philosophical tradition and the formation of a sociological methodology. Accordingly, he viewed fashion both as an abstract concept that generates and influences cultural perception and as a defining factor in social and interpersonal relations. Simmel’s beginnings as a neo-Kantian philosopher prepared his view of cognition as a biological process of adaptation by human beings to their environment, a view which is not only situated in a scientific (neo-Darwinian) discourse but also extended to culture—intellectual as well as sensory—within a contemporary (modern and urban) environment. Simmel defined the truth within expressions of reality pragmatically through its appropriateness for living practice. This led him to the emerging discipline of sociology, which developed the ground for direct application of such concepts to sociopolitical existence. His precursors herein were Auguste Comte, Herbert Spencer, and Gabriel Tarde, and among his contemporaries were Ferdinand Tönnies, Werner Sombart, Émile Durkheim, and Marcel Mauss.

### Early Investigations

The methodological mix of metaphysics, economics, and social theory generated for Simmel an interest in fashion, which he viewed as a theoretical and material field of investigation that offered space for emphatic, almost

literary, evocations of clothing but also for a formal description of (dress) codes as visual and structural primers for social groups and settings. He began to investigate the topic in an 1895 essay titled “Zur Psychologie der Mode” (On the psychology of fashion). In this essay, Kantian heritage accounts for a philosophical focus on the subject-object relation. Simmel asks where cognition is founded, in the objects of cognition or in the cognitive subject itself. He applies the question to fashion: Is cognition founded in the clothes we choose to wear, or is it the human mind that chooses the clothes? In this, his first essay about fashion, cognition and self-awareness are regarded as creative achievements of the subject, aided by guidelines extracted from the conglomerate of experience.

In his book *The Philosophy of Money*, Simmel returned to the progressive division of subject and object in modernity, this time applying socioeconomic criteria. In this work Simmel devotes a telling passage to fashion, describing how “the radical opposition between subject and object has been reconciled in theory by making the object part of the subject’s perception,” partly through a practice that produces the object by a single subject for a single subject. In modernity, mass production—with its division of labor—renders such reconciliation impossible. The analogy that Simmel draws here is “the difference ... between the modern clothing store, geared towards utmost specialisation, and the work of the tailor whom one used to invite into one’s home” (Simmel, p. 457). The example is indicative of Simmel’s approach. Not only does the object of fashion—more than any other object of consumption that must remain at a distance from the body—allow for an introduction of sensuality and haptic experience within theory, but it also applies abstract concepts directly to corporeality. In discussing the production and consumption of fashion, Simmel leads the reader directly back to his or her own experience as a wearer of clothes and as a modern consumer, thus generating an important link to personal experience that coined contemporary philosophy (Simmel’s subsequent term *Lebensphilosophie* [metaphysics of existence] would follow French philosopher Henri-Louis Bergson’s *élan vital*, or nature’s creative impulse).

In 1904–1905 two extended essays by Simmel were published—one in English under the simple heading “Fashion” and one in German titled “Philosophie der Mode” (Philosophy of fashion). They share a similar structure, but the former set an empiricist or rationalist tone that would determine Simmel’s reception in Anglo-Saxon social sciences as a formal sociologist and precursor to the Chicago school of empiricist, urban sociology.

Akin to set theory, Simmel describes in his sociology the developmental process of social differentiation as a confluence of the homogeneous segments of heterogeneous circles. In modern (especially urban) culture both psychological and social differentiation are geared to

minimizing physical friction and channeling the energy of personal collisions into dynamic movement as an economic principle (e.g., competition). Fashion exemplifies this process acutely. The complex mix within modern dressing between invention and imitation, between socially sanctioned conformity for societal survival and necessary independence for personal gratification and the formation of the self (even cognition), is found in all clothing rituals and codification. The abstract and generalized tone with which fashion is debated makes Simmel's analyses still pertinent in the twenty-first century, because he eschewed historicity, romanticism, or concreteness vis-à-vis sartorial styles.

### Key Observations about Fashion

Two sets of his observations, in particular, render fashion a generic model both for the recognition of societal procedures and a phenomenology of modernity itself. The first is the import of fashion by strangers from outside a given set or circle. Here the term "role-playing," which would become so significant for modern sociology, is prefigured. In his essays Simmel analyzes how a style or appearance of dress undergoes a developmental process of rejection to acceptance. "Because of their external origin," he wrote in 1904, "these imported fashions create a special and significant form of socialization, which arises through mutual relation to a point without the circle. It sometimes appears as though social elements, just like the axes of vision, converge best at a point that is not too near.... Paris modes are frequently created with the sole intention of setting a fashion elsewhere" (Simmel; 1904, p. 136). The methodological move from anthropology to economics here is characteristic for the formation of early social theory. Also, the strong interest in temporal structures (partly influenced through Bergson's *durée*, the natural milieu of a person's "deep self, or the true foundation of one's spiritual identity") and accelerated rhythm of modernity leads Simmel to a contemplation of sartorial transitoriness.

In the last of his four essays on fashion, "Die Mode" (Fashion, 1911), he explains how wider acceptance and distribution of a fashion herald its demise, since a widely accepted dress code no longer poses to the individual a challenge that is associated with the constitutive process of fractious assimilation. Accordingly, a novel form or style of clothing needs to be introduced to generate anew the dualities of innovation and imitation, social separation and inclusion. As soon as fashion manages to determine the totality of a group's appearance—which has to be its ultimate creative and economic aim—fashion will, owing to the logical contradiction inherent in its characteristics, die and become replaced. And the more subjective and individualized a style of clothing is, the quicker it perishes. For Simmel, this transitory character of fashion remains its essence and elevates its material objects to transhistorical significance. "The question of fashion is not 'to be or not to be,'" he concluded in 1911, "... but it always

stands on the watershed between past and future" (Simmel: 1911, p. 41).

See also Benjamin, Walter; Fashion, Theories of.

### BIBLIOGRAPHY

- Böhringer, Hannes, and Karlfried Gründer, eds. *Ästhetik und Soziologie um die Jahrhundertwende: Georg Simmel*. Frankfurt am Main, Germany: Vittorio Klostermann Verlag, 1976.
- Dahme, Heinz-Jürgen, and Otthein Rammstedt, eds. *Georg Simmel und die Moderne*. Frankfurt am Main, Germany: Suhrkamp, 1984.
- Frisby, David. *Fragments of Modernity: Theories of Modernity in the Work of Simmel, Kracauer, and Benjamin*. Cambridge, U.K.: Polity Press, 1985.
- . *Sociological Impressionism: A Reassessment of Georg Simmel's Social Theory*. 2nd ed. London: Routledge, 1992.
- Kaern, Michael, Bernard S. Phillips, and Robert S. Cohen, eds. *Georg Simmel and Contemporary Sociology*. Dordrecht, Germany: Kluwer Academic Publishers, 1990.
- Lehmann, Ulrich. *Tigersprung: Fashion in Modernity*. Cambridge, Mass.: MIT Press, 2000.
- Lichtblau, Klaus. *Kulturkrise und Soziologie um die Jahrhundertwende*. Frankfurt am Main, Germany: Suhrkamp, 1996.
- Rammstedt, Otthein, ed. *Simmel und die frühen Soziologen: Nähe und Distanz zu Durkheim, Tönnies, und Max Weber*. Frankfurt am Main, Germany: Suhrkamp, 1988.
- Remy, Jean, ed. *Georg Simmel: Ville et modernité*. Paris: Éditions L'Harmattan, 1995.
- Simmel, Georg. *On Individuality and Social Forms: Selected Writings*. Edited by Donald N. Levine. Chicago: University of Chicago Press, 1971.
- . *Georg Simmel on Women, Sexuality, and Love*. New Haven, Conn.: Yale University Press, 1984.
- . *Gesamtausgabe*. Edited by Otthein Rammstedt. Frankfurt am Main, Germany: Suhrkamp, 1989–2002.
- Wolff, Kurt H., ed. *The Sociology of Georg Simmel*. Glencoe, Ill.: Free Press, 1950.

Ulrich Lehmann

**SKATING DRESS** Although skating is an activity that takes many forms—each with its unique clothing requirements—ice-skating, and specifically figure skating, provides the most prominent image of the skating dress. Figure skating is an athletic and expressive sport. Whether skating recreationally on a frozen-over outdoor pond or as a competitor with a rigorous daily training schedule on an indoor rink, clothing plays a major role in enhancing the experience.

The movements involved in figure skating engage the entire body. The motion and flow across the ice requires smooth actions of the arms and legs along with powerful gliding strokes, quick turns and rotations, explosive jumps, and fast footwork. The clothing that the skater wears can enhance these movements while at the

same time allowing the skater to maintain a comfortable temperature while moving efficiently and without distraction. This blend of aesthetic and functional possibilities of dress mix in action to become almost one with the skater, the result being a total athletic and artistic expression.

Beginning with the functional requirements, the regulation of body temperature is primary. Skaters start a workout by wearing layers, shedding sweaters or jackets as they warm up, and donning them again as they cool down. The ability to move freely is key to performance. Therefore, outfits are close to the body, allowing for movement without the garments getting in the way of action. Women typically wear tights or snug pants that protect the legs from abrasions during falls. Many wear short skirts or dresses, and long-sleeved tops with plenty of stretch. Men wear close-fitting pants and shirts. The skates (boots and blades) are usually white for women and black for men. Laces keep the boot securely fitted to the foot and the ankle supported, yet allowing for bend and movement. Accessories are minimally worn so as to not interfere with fast moves or get caught or tangled in hair or garments. Gloves provide extra warmth and protection, and hats or headbands warm the head and secure the hair.

The aesthetic component of skating dress at best enhances the sensation of movement, while connecting the overall visual effect to the music and theme of the skater's performance. Competition clothing is much dressier and showier than everyday practice dress. The possibilities are almost endless, given the intended expressive results. Sequins, rhinestones, jewels, and shiny textures reflect light and add excitement and elegance. Flowing, lightweight fabrics lift and float as they move across the ice with the skater. The placement of embellishments actively draws the eye to various locations on the body, whether centered in predictable neckline and skirt edging or along sleeves or pants to enhance arm and leg extensions. Sometimes the visual activity in a costume can overtake the overall impression, almost negating the skater, and at other times, subtle highlights in dress put the skater's body as the primary point of attraction. The most exquisite outcome occurs when the skater's body and the dress work together to form action and visual effect, one enhancing the other within the context of the performance.

Behind aesthetic and performance possibilities are major advances in fabric technology. The functional requirements of movement and comfort have been greatly enhanced by the development of fabrics with stretch. Prior to the development of elastine fibers, particularly Lycra, skaters' ensembles were limited to nonstretch fabrics, or bulky knits with limited range and recovery. This meant that movement potential was designed into garments by placing gussets (small patches of fabric joining garment sections, such as at the armpit) so that the arm could move above the shoulder without the sleeve lifting the rest of the garment.



**Figure skater Oksana Baiul.** Gold-medal winner Oksana Baiul, of Ukraine, during the figure skating competition at the 1994 Winter Olympics in Lillehammer, France. The outfits of competitive skaters like Baiul are designed for freedom of movement and artistic effect. GETTY IMAGES. REPRODUCED BY PERMISSION.

As more fiber combinations became possible, skaters were no longer limited to pleats, gores, drape, and gathers to provide shape and fullness. Layers of lightweight novelty fabrics rich with embellishments can create theatrical aesthetic effects without the heavy structural constraint of days past. Adding to the design possibilities is a sheer mesh fabric that can “bare” the skin and support sparkles and trims. Now skating costumes can be created to cover the body strategically, and still stay on and function with extreme movement demands. The possibilities are unlimited.

Skating dress has evolved to reflect the spirit of the times as well as dress regulations of everyday fashion. In the early twentieth century, skirts were worn to the top of the skate, reflecting the modesty practice of women not showing their legs despite the movement restrictions. As women's status advanced and their place in sport widened, skirts became shorter and necklines lower. Although this is a simplified observation, along with other forms of athletic apparel (for gymnasts and dancers), skating dress evolved to allow the body to be more primary in viewing and in action potential. Dress now supports and enhances women as athletes. Men had traditionally been in the background, relative to skating dress. Instead of a “flashy” presence in competitions, men mostly wore outfits that resembled suits that had limited decoration. As with women's dress, men's dress has since evolved along with attitudes toward gender roles. Now male



skaters often wear costumes that are every bit as showy and elaborate as women's dress.

Because skating is a popular spectator sport, skaters in the spotlight have been behind many fashion trends. Dorothy Hamill and her bobbed hair is an example of this. The elegance and excitement of skating dress in major competitions is awaited by some people with the same anticipation commonly seen on Oscar night in Hollywood. Although the form of the dress is unique to skating, the colors, textures, and surface embellishments, often inspire and follow fashions in other environments

Skating dress is at best a synergy of artistry, comfort, and movement. It is a part of a total experience, reflecting athleticism and cultural expression.

See also **Activewear; Sportswear.**

#### BIBLIOGRAPHY

Stephenson, Lois and Richard. *A History and Annotated Bibliography of Skating Costume*. Meriden, Conn.: Bayberry Hill Press, 1970.

*Janet Hethorn*

**SKI CLOTHING** During the nineteenth century, enthusiasts and explorers helped transform skiing from a practical activity into a sophisticated sport. Along with its growing popularity came progress in equipment and clothing to protect the body from mountain extremes. Experienced skiers realized the importance of layering, which enabled them to take off or put on clothing as required, tailoring what they were wearing to the activity level. The layers comprised lightweight long underwear and stockings, sweater, socks, gloves, and a weatherproof coat and breeches. Long skirts were inappropriate for the rigors of skiing, so by 1910, the only difference between male and female skiwear was a knee-length skirt worn over knickerbockers. Burberry gabardine was recognized as the most suitable fabric for jackets and breeches as its proofed cotton threads, dense weave, and smooth surface

provided a barrier to the wind and snow. Unlike earlier rubberized and waxed jackets it was also breathable.

Uniforms worn during World War I had an impact on skiwear. By 1920 outfits based on tunics and breeches worn by the British Land Girls (a volunteer corps of agricultural workers known as the "Women's Land Army" that substituted for men who had enlisted during the war) began to appear. More relaxed attitudes toward fashion made it easier for women to wear this type of clothing without fear of criticism. Sportswear manufacturing companies also incorporated practical elements from male military uniform into their designs, such as buttoned top pockets. During the 1920s trousers rapidly became an accepted form of clothing, and the women's skiing outfit signalled a dress equality less evident back home, where trousers were still taboo for most activities.

#### Development

The growth of ski tourism and the first winter Olympics in 1924 encouraged manufacturers to specialize in skiwear and create weatherproof yet fashionable outfits. Companies such as Drecoll, Burberry, Lillywhites, and Aquascutum and fashion designers including Patou, Lanvin, and Regny produced trouser suits in a wide range of colors, combining practicality with elegance. The main technical advances were in design features such as zip fastenings, which were more effective at sealing openings on trousers, jackets and pockets than buttons or laces. By the early 1930s, short jackets inspired by pilots' uniforms, and full "Norwegian" trousers were fashionable for men and women. These loose-fitting garments allowed greater freedom of movement and a more casual style to prevail.

During the 1930s the mechanization of the ski industry in the form of rope tows and ski lifts started to impact the design of ski outfits. The shift from mountain touring to downhill skiing demanded a different design of clothing. Fashion gradually shifted away from baggy styles to shaped trousers that followed the streamlined look of ski racers and were better suited to the new skiing techniques.

Equipping the forces during World War II led to the manufacture of high quality outdoor clothing, including skiwear. Developments in synthetic fibers and polymers for the mountaineering troops brought about improvements in materials for ski clothing. Nylon was used in the outer shell of stylish parkas and synthetic quilted linings were added for extra warmth. Stretch nylon pants suited the streamlined look of 1950s' skiwear perfectly, emphasizing the fashionable curve of the hips and a narrow waist. They could be teamed up with colorful mohair sweaters for after skiing or worn as slacks at home. Specialist manufacturers and a new generation of fashion designers such as Balmain and Pucci capitalized on these styles, creating fashionable yet functional clothing.

In 1959 the arrival of spandex heralded another revolution in ski clothing. This elastomeric fiber was com-



"The ski outfit that one puts on in the morning is the same as that which one wears until dinner. One of the most surprising aspects of St. Moritz is this contrast between the . . . luxury of hotels and the casual appearance which the winter sports costume gives to the guests."

*Vogue*, 1 December 1926 (Paris: Editions Condé Nast): 9.

bined with other synthetic fibers or wool to allow greater stretch than nylon plus instant recovery. Skiwear could now stretch with the wearer and retain its shape. Spandex was ideal for ski racing outfits, allowing greater freedom of movement and aerodynamic qualities. Inspired by events such as the Olympic games, Pucci, Hermès, and Dior featured tight stretch ski pants and curvaceous all-in-one suits in their 1960s' collections. Experts, however, advised looser versions for recreational skiing that, when combined with turtlenecks, functioned for social occasions and other outdoor activities.

### Technology

In the 1970s growing numbers of companies such as Killy, Lange, and Berghaus started to provide specialist clothing, and a kaleidoscope of designs evolved to suit all tastes and levels of skier. Wider-legged, over-the-boot pants created a more relaxed look in tune with mainstream fashion and quilted down-filled jackets were versatile additions to the skiing wardrobe. V. de V. and de Castelbajac created flamboyant designs in authentic ski clothing while warm-up suits worn by ski racers were translated into fashionable styles. Novelty fabrics such as fake fur, vinyls, and metallics were used for parkas, and ski outfits in psychedelic color combinations had a safety as well as aesthetic appeal. Ponchos and capes were popular for après-ski and "space-age" moon boots walked their way into the fashion scene.

There were also significant developments in technology. In 1969, plastic molded boots replaced the traditional leather footwear, giving the skier greater control over the skis. Plastic coatings were introduced onto ski garments to keep out moisture, but although waterproof, they led to a buildup of condensation inside. Introduced in 1976, Gore-Tex fabric revolutionized outdoor wear by allowing perspiration to escape while keeping water out. It was developed for ski clothing in collaboration with Berghaus, and soon other companies were promoting their own versions. The development of circular knit brushed fleece in the late 1970s also transformed skiwear. Made of lightweight, warm, and quick-drying polyester filaments, it made layering garments as a means to keep warm easy and became a staple in casual outerwear.

### Innovation

As the latest technologies were incorporated into skiwear, leading brands faced fierce competition to market a new wonder fiber or design feature. During the 1980s branding with logos became increasingly common, and the choice of clothing was almost bewildering. Fashion was also of prime importance and manufacturers such as Killy, Luhta, Head, Elho, and Ocean Pacific styled their outfits to complement the latest trends. Fluorescent colors, soft pastel shades, and striking abstract and animal designs were all featured. A casual "winter surf" look emerged among young winter sports enthusiasts. One-piece suits were often zipped at the waist for more ver-



**Two women model ski clothing, 1929.** During the 1920s, trousers became a rapidly accepted form of women's ski clothing, an equality in clothing that was not reflected in attire outside of the sport. PUBLIC DOMAIN.

satility, and bib pants (known as salopettes in the United Kingdom) became an increasingly important component of the jacket-and-pants combination. The popularity of sportswear for leisurewear also meant that ski pants and quilted jackets made their way into the high street.

In the new millennium, the booming snowboarding industry and rise of extreme winter sports have encouraged skiwear manufacturers to emphasize innovation. Fabrics with ever increasing property and performance tolerances such as "soft shell" constructions with welded waterproof zips, jackets with inflatable insulating air pockets, and seam-free underwear promise to transform the skiing experience. The increasing use of helmets and the incorporation of body armor into skiwear, including back protectors and built-in lumbar supports, have improved safety on the slopes. Competition has also encouraged manufacturers to diversify, focusing on specific "looks" for different styles of skiing and ensuring that more components of the outfit than ever before can be worn on or off the slopes.

*See also* **Sportswear.**

## BIBLIOGRAPHY

- A-Z Ski Fashion and Equipment Guide*. London: Hill, 1988.
- Loring, Maggie. *Skiing*. Camden, Me., and London: Ragged Mountain Press/McGraw-Hill, 2000.
- Lunn, Sir Arnold. *A History of Skiing*. London: Humphrey Milford, 1927.
- Scharff, Robert. *SKI Magazine's Encyclopedia of Skiing*. New York and London: Harper and Row, 1976.
- Skiing International Yearbook*. New York: Periodical Publications, 1965.

Lucy Johnston

**SKIRT** The skirt, the lower part of a gown or robe that covers the wearer from waist downward, has been called “the simplest and most obvious of garments” by John Flügel (p. 35). He theorized that “tropical” skirts, which developed as a class of clothing distinct from “arctic” bifurcated forms, had certain advantages: “Instead of being supported on just two legs with nothing but thin air between them, a skirted human being assumes much more ample and voluminous proportions . . . often with great increase of dignity” (p. 35).

In Western culture, both genders long exploited the skirt's inherent characteristics, but since the sixteenth century a true skirt has not been a feature of standard masculine dress (if, with Anne Hollander [1994], one excepts the male kilt as a survival of drapery). The skirt separated from the dress bodice in the early sixteenth century; shortly thereafter “skirt” became synonymous with a woman, at first as standard English and then as slang in the nineteenth century. The skirt had become the defining female garment.

For several centuries feminine skirts were often very full, worn over petticoats, and sometimes supported by understructures and lengthened with trains. According to Hollander, shrouded legs visually confused rather than explained the structure of the female body. An inherent dichotomy was imagined between women's mysterious skirted forms—that included no type of bifurcated garment, not even as underwear—and tightly garbed trousered males, as illustrated by the furor over the Bloomer fashion of the 1850s.

While expansive and expensive skirts of previous eras may have demonstrated women's abstinence from productive employment, the slimmer line of the early twentieth century was restrictive in other ways, culminating in the “hobble skirt” of about 1910. Mobility, however, triumphed in the 1920s as skirts shortened to reveal women's legs. A new statement in the continuous dialogue between modesty and sexual attractiveness, the shortened skirt was, Hollander believes, “the most original modern contribution to feminine fashion accomplished without recourse to the standard male vocabulary” (p. 146).

For much of the rest of the twentieth century, hemlines served as the primary indicator of fashionability, al-

ternating higher and lower, from extravagantly long New Look skirts to scanty miniskirts and “micro-minis.” To explain seemingly quixotic hemlines, inventive (if unsubstantiated) theories linked short skirts with high stock prices. By the 1970s pants increasingly comprised an accepted part of women's wardrobes. In *The Woman's Dress for Success Book*, however, John T. Molloy, advised businesswomen to avoid what he called the “imitation man look,” by wearing skirted suits with the hem length fixed at slightly below the knee, thus “taking a major step toward liberation from the fashion industry” (p. 51). Since that time, however, the array of feminine skirts has only gotten more eclectic—slit, tight, see-through, or full in any length from floor to crotch. Short skirts remain a way to attract attention, whether admiring or outraged. Flaunting legs under an abbreviated skirt has been interpreted as a form of feminine empowerment.

Wearing a skirt has become a choice for women, and since the 1990s even a rare and provocative masculine sub-fashion. Yet the tenacity of this garment as a female signifier is evidenced by standardized international gender symbols: with no innate anatomical basis for the skirt of one figure, cultural conditioning makes her femininity instantly indisputable.

See also **Bloomer Costume**; **Crinoline**; **Miniskirt**.

## BIBLIOGRAPHY

- Bolton, Andrew. *Bravehearts: Men in Skirts*. London: Victoria and Albert Museum, distributed by Harry N. Abrams, Inc., 2003.
- Flügel, John Carl. *The Psychology of Clothes*. London: Hogarth Press, 1930.
- Hollander, Anne. *Sex and Suits: The Evolution of Modern Dress*. New York: Alfred A. Knopf, Inc., 1994.
- Molloy, John T. *The Woman's Dress for Success Book*. New York: Warner Brooks; Chicago: Follet Publishing Co., 1977.
- Tarrant, Naomi. *The Development of Costume*. Edinburgh: National Museums of Scotland, 1994.

H. Kristina Haugland

**SKIRT SUPPORTS** The skirt, for centuries the defining feminine garment in Western fashion, can be expanded to increase the wearer's apparent size and thereby her importance and dignity. Skirts are often given volume by cloth petticoats, but stiffer structures are more effective and may be lighter and more comfortable; when exaggerated, however, these supports can become amazingly encumbering. Skirts have been supported at the back by bustles, while extended skirt circumferences have been produced by farthingales in the sixteenth and early seventeenth centuries, *paniers* in the eighteenth century, and crinolines or hoop skirts in the mid-nineteenth century.

Around 1470, fashionable Spanish women began to hold their skirts out with bands of heavy cord or rope in casings on the outside of their skirts. From this, a sepa-



rate hooped underskirt developed that abstracted a woman's legs into a seemingly motionless cone shape. By the 1540s this fashion had spread to other countries, including England, where it was known as the verdingale or farthingale, derived from the Spanish *verdugo*, a type of flexible twig also used as hoops for skirts. This conical skirt, called the Spanish farthingale, stiffened with whalebone, wire, or other material, became very wide in the early 1580s. About his time, women's hips began to be augmented by padded rolls, altering the skirt silhouette into a shape termed the French farthingale. By the 1590s, French farthingales could take the form of a wheel or drum that held the skirt out from the waist at right angles. Exclusive to the upper classes, these supports magnificently displayed rich, heavy skirt fabric, which, as authority Janet Arnold shows, was fit in place by a servant who pinned in a horizontal fold to form a ruff-like flounce at the top of the skirt. Farthingales began to go out of fashion in England in the late 1610s, but the style lasted somewhat longer in France, and as Spanish court dress it continued into the 1660s.

The wish to distend the skirt returned in the early eighteenth century. By about 1710, fashionable skirts were supported by devices called hoop-petticoats or hoops in England and *paniers* (baskets) in France. These structures were at first dome-shaped, but by mid-century were usually flattened front to back into an oval or took the form of separate side or "pocket" hoops; they were typically of stiff fabric reinforced by hoops of whalebone, wood, or cane, but could be open frameworks of metal or other material. Hoops were usually modestly sized for informal wear, but often reached over six feet from side to side for formal occasions, necessitating some skillful maneuvering such as going sideways through doors. While large hoops were labeled monstrous by some, others believed they gave women elegance and grace, and ensured each was physically distinct. Extreme hoop-petticoats also distinguished the elite who wore them, functioning, according to Henry Fielding, as an "Article of Distinction" between classes.

Although they were going out of style by the 1770s, large *paniers* continued to be *de rigueur* at the French court until the revolution of 1789. Just as the earlier farthingale had fossilized as Spanish court dress, side hoops were retained until 1820 at the English court, worn anachronistically with high-waisted neo-classical dresses. Skirt supports may have been intended to bestow dignity and grace, but the result was sometimes antithetical: in *The Art of Dress* (p. 123), Aileen Ribeiro cites an early nineteenth century observation that a behooped lady stuffed into a sedan chair "does not ill resemble a foetus of a hippopotamus in its brandy bottle."

See also **Bustle**; **Crinoline**; **Skirt**.

#### BIBLIOGRAPHY

Arnold, Janet. *Patterns of Fashion: The Cut and Construction of Clothes for Men and Women, c1560–1620*. London: Macmillan, 1985.

———. *Queen Elizabeth's Wardrobe Unlock'd* Leeds, U.K.: W. S. Maney, 1988.

Cunnington, C. Willett and Phillis. *The History of Underclothes*. London: Michael Joseph Ltd, 1951 (new edition revised by A. D. Mansfield and Valerie Mansfield published in London by Faber and Faber, 1981).

Ewing, Elizabeth. *Dress and Undress: A History of Women's Underwear*. London: Bibliophile, 1978.

Ribeiro, Aileen. *The Art of Dress: Fashion in England and France, 1750–1820* New Haven, Conn., and London: Yale University Press, 1995.

———. *Dress in Eighteenth Century Europe, 1715–1789*. London: B. T. Batsford, 1984.

Waugh, Norah. *Corsets and Crinolines*. New York: Theatre Arts Books, 1954.

H. Kristina Haugland

**SLIP** Petticoats or underskirts have been used for centuries to support the various shapes of the skirt, add warmth, and protect outer garments. Since the seventeenth century the word slip was occasionally used for certain garments worn under sheer dresses, but the forerunner of the modern slip originated in the late nineteenth century, when the petticoat was combined with a chemise or corset cover to form a one-piece, fitted, sleeveless undergarment. Because this garment used a princess cut, which shaped the bodice and skirt by vertical seaming, it was called a "princess petticoat" or "princess slip." In the early twentieth century, it came to be called a costume slip, and then merely a slip.

As an underdress or underskirt, a slip provides a middle layer that mediates between underwear and outerwear. Among its functions, a slip can make transparent garments more modest and eliminate rubbing and unsightly clinging. Originally slips were of daintily trimmed cotton or occasionally of silk, although by the 1920s rayon was widely used. The straight-cut tubes of that period gave way to more fitted slips that accentuated the figure. In the mid-twentieth century, newly invented nylon was preferred since it was washable, drip dry, required no ironing, and was also inexpensive and colorfast. Advertisements stressed that slips were durable, shadow-proof, and cut to never embarrassingly ride up. Good taste demanded that a slip be long enough—ideally exactly one inch shorter than the outer garment—but *never* show at the hem. For all their opaque respectability, slips were molded to the contour of the body, often daintily decorated, and ordinarily hidden from view, giving them a certain eroticism. Films and publicity photographs of stars and starlets of the time exploited the allure of the slip, most famously on Elizabeth Taylor in the 1958 film version of Tennessee Williams's *Cat on a Hot Tin Roof*.

With the general reduction of underwear in the 1960s some full slips incorporated bras while half-slips, bright colors, and patterns became increasingly popular.

As skirt hems rose, slip lengths shortened, but they remained provocative garments. In 1962 Helen Gurley Brown's *Sex and the Single Girl* advised would-be flirts that showing a bit of lovely lingerie is sexy, citing a girl whose "beautiful half-slips (she has them in ten colors) always peek-a-boo a bit beneath her short sheath skirts when she sits down" (p. 78). Nevertheless, in the following decades slips came to be associated with prudish and frumpy older women. A candid photograph from 1980 caught Lady Diana Spencer, the shy young fiancée of the Prince of Wales, in a lightweight skirt against the sun, revealing the outline of her legs and her relinquishment of this once mandatory undergarment.

The slip, however, was reborn as a result of the "underwear as outerwear" phenomenon of the early 1990s. The "slip dress" became a nostalgic yet daring fashion favorite, edgily imbued with the frisson of lingerie. Its revealing cut, lightweight fabric, and spaghetti straps precluded supportive undergarments, requiring a toned body and a confident attitude. As slip dresses became more popular, they were made more practical by women and even designers who layered them over white T-shirts, completing the slip's transmutation from undergarment to outerwear.

See also **Lingerie; Nylon; Petticoat.**

#### BIBLIOGRAPHY

- Brown, Helen Gurley. *Sex and the Single Girl*. New York: B. Geis Associates, 1962. Reprint, Fort Lee, N.J.: Barricade Books, 2003.
- Cunnington, C. Willett, and Phillis Cunnington. *The History of Underclothes*. London: Michael Joseph Ltd., 1951. Reprint, London: Faber and Faber, 1981.
- Ewing, Elizabeth. *Dress and Undress: A History of Women's Underwear*. London: Bibliophile, 1978.

H. Kristina Haugland

**SMITH, PAUL** Paul Smith is renowned for classic garments that also demonstrate a discreet eccentricity that is essentially as British as his name. Committed to the idea of creative independence, he is Britain's most commercially successful designer, with a turnover of £230 million and retail outlets in forty-two countries.

Born in the city of Nottingham in 1946, he left school at age fifteen and began his career running errands in a fashion warehouse. When he was only seventeen, he was instrumental in the success of a local boutique, running the men's wear department and sourcing labels that were previously unavailable outside of London. In 1970 he opened his first shop, a three-meter-square room at the back of a tailor's space, together with a basement that he turned into a gallery, where he sold limited edition lithographs by Warhol and Hockney. He recalled,

I had ... [m]odern classics you couldn't get anywhere else. I knew that ... if I started selling clothes that I didn't like, but that lots of people did want, then the job would have changed me. I called the boutique Paul Smith as a reaction to the silly names ... [of] the time (Fogg, p. 130).

Smith began manufacturing and retailing shirts, trousers, and jackets under his own label, and in 1976 he showed for the first time in Paris. The opening of the first Paul Smith store in London's Covent Garden in 1979 coincided with a resurgence in the money markets of the city and subsequent changes in social attitudes. His suits for men became standard wear for the 1980s young urban professional, the "yuppie." "Young people were willing to wear suits and were not embarrassed about saying that they had money. That was what the 1980s were all about and my clothes reflected the times" (Smith p. 148). Smith's amalgamation of traditional tailoring skills with a witty and subversive eye for detail, together with his quirky use of color and texture, allowed his customers the reassurance that it was permissible to be fashion conscious without being outrageous. It was this particular brand of Britishness that appealed to the Japanese market, where Smith has a £212 million retail business of more than 240 shops. As the Paul Smith style infiltrated mainstream retail chains on the High Street, his company developed a stronger fashion emphasis, and in 1993 he introduced a women's wear collection.

An important element of Smith's shops has always been his ability to source quirky and idiosyncratic objects to sell alongside the clothes. With the opening of the Westbourne Grove shop in London's Notting Hill Gate in 1998, he introduced another retail concept, that of the shop as home, and he has diversified into home furnishings. Smith has always been concerned that each shop is individual and reflects the unique quality of the city in which it is placed, rather than presenting a homogeneous ideal that is brand- and marketing-led. In the year 2000 Queen Elizabeth II knighted him for his services to the British fashion industry.

See also **Suit, Business; Tailored Suit; Tailoring.**

#### BIBLIOGRAPHY

- Fogg, Marnie. *Boutique: A '60s Cultural Phenomenon*. London: Mitchell Beazley, 2003.
- Smith, Paul. *You Can Find Inspiration in Anything: (And If You Can't, Look Again!)*. London: Violette Editions, 2001.

Marnie Fogg

**SMITH, WILLI** Born Willi Donnell Smith in Philadelphia on 29 February 1948, Smith studied fashion illustration at the Philadelphia Museum College of Art from 1962 to 1965 and continued his studies in fashion design at the Parsons School of Design in New York

City from 1965 to 1967. He died at age thirty-nine on 17 April 1987. According to Liz Rittersporn of the *New York Daily News*, he was the most successful black designer in fashion history.

On leaving college, Smith worked as a fashion illustrator with Arnold Scaasi for several years. From 1967 to 1976 he also worked as a freelance designer for companies such as Bobbi Brooks and Digits Inc. He specialized in sportswear, injecting an element of playfulness into functional garments such as the jump suit that he cut out of silver-coated cloth. In 1976 he and Laurie Mallet, who subsequently became president of the company, established the successful label WilliWear Limited, which captured the spirit of pragmatic leisurewear. Together they launched a collection of clothes consisting of thirteen silhouettes in soft cotton, manufactured in India and sold in New York. Such was the demand for the relaxed styling and affordable clothes of the label that the company's revenue grew from \$30,000 in its first year to \$25 million in 1986.

In 1978 Smith added a men's wear collection, and in 1986 he designed the navy, linen, double-breasted suit worn by Edwin Schlossberg for his marriage to Caroline Kennedy, together with the violet linen blazers and white trousers worn by the groom's party. He was, however, primarily a designer of women's wear. From its origins in a single New York store, the company went on to open offices in London (a boutique in St. Christopher's Place), Paris, and Los Angeles, as well as more than a thousand outlets in stores throughout the United States. The Paris store—his first eponymous store—opened posthumously in 1987. Just before his untimely death that year, he expressed his desire to Deny Filmer of *Fashion Weekly* to see all WilliWear products housed under one roof. "I want my stores to be a little funkier, like, wilder and fun to go into. You know that wonderful feeling when you go into an army surplus store, they have an unpretentious atmosphere. I don't want to push a lifestyle" (p. 7).

Smith's attitude toward fashion was democratic and the antithesis of the ostentatious 1980s. His main concern was that his clothes should be comfortable and affordable. He was dismissive of the edict "dress for success," identifying with the youth cults he saw on the streets of New York and drawing much of his inspiration from them. To this end he provided comfortable, functional clothes in soft fabrics that did not restrict the body in any way. He very often chose Indian textiles for their suppleness, diffused colors, and attractively distressed quality. His clothes were moderately priced, loose-fitting, occasionally oversized separates. Skirts were full and long and jackets oversized, in natural fabrics that wore well and were easy to maintain.

He disliked the pretentiousness of haute couture. "I would love to have a salon and design couture collections, but it's so expensive ... and I hate the theory of 'We the

rich can dress up and have fun, and the rest can dress in blazers and slacks.' Fashion is a people thing, and designers should remember that" (Filmer, p. 9).

Smith's obituary in the *Village Voice* (28 April 1987) by Hilton Als read,

As both designer and person, Willi embodied all that was the brightest, best and most youthful in spirit in his field. ... That a WilliWear garment was simple to care for italicised the designer's democratic urge: to clothe people as simply, beautifully, and inexpensively as possible.

For a brief period after his death, the company continued to function, and it opened its own store on lower Fifth Avenue in New York. In 1996 WilliWear was relaunched, designed by Michael Shulman, and available in T.J. Maxx stores.

Although never an innovator, Willi Smith represented a paradigm of casual American style, creating affordable classic separates. Their functionality and informality was not reliant on overt sexuality or on the status implied by high fashion, and they appealed to a broad spectrum of people. Smith received the Coty American Fashion Critics Award in 1983, and New York City designated 23 February as "Willi Smith Day." He was also honored by the Fashion Walk of Fame.

See also **Fashion and Identity**.

#### BIBLIOGRAPHY

- Filmer, Deny. "Just William." *Fashion Weekly* (London). (12 February 1987).
- Milbank, Caroline Rennolds. *New York Fashion: The Evolution of American Style*. New York: Harry N. Abrams, 1989.
- Rittersporn, Liz. "Designer Willi Smith Is Dead." *New York Daily News* (19 April 1987).

Marnie Fogg

**SNEAKERS** The first athletic shoes were created thousands of years ago to protect the foot from rough terrain when hunting and participating in combat games (Cheskin 1987, pp. 2–3). In Mesopotamia (c. 1600–1200 B.C.E.) soft shoes were worn by the mountain people who lived on the border of Iran. These shoes were constructed with crude tools such as bone needles and stone knives; and made of indigenous materials like leaves, bark, hide, and twine. With the available manufacturing processes and materials, primitive shoes were only constructed as sandals or wraparound moccasins. In a sandal construction the foot is attached to a platform with straps, bands, or loops. A moccasin construction entails a piece of material wrapped under and over the top of the foot then anchored with a drawstring. As sports became more competitive throughout history, athletic shoes needed to perform better and be sport-specific. Functional attributes like weight, flexibility, cushioning,



and traction became key features to making successful athletic shoes.

### Folklore

According to some historians, King Henry VIII of England expressed ideas related to an athletic sneaker-type construction in the 1500s. According to folklore, the king was getting a bit overweight, and he decided playing tennis would be a good way to get in shape. But he was not happy with the shoes he had. He ordered his servant to get “syxe paire of shoos with feltys, to pleye in at tennis” (six pairs of shoes with felt bottoms to play tennis in), from the local cobbler (Paquin 1990). Although the king was not exactly ordering sneakers, as we technically know them, he had the right idea—to make lightweight shoes with a separate functional outsole to play tennis better.

### What Is a Sneaker?

The word “sneaker” was a marketing term coined in the United States many years after the actual shoe construction was created. “Sneaker” is one of many names given to a shoe that consists of a canvas upper attached to a vulcanized rubber outsole. A shoe made any differently (e.g., a shoe with a foam midsole and a stability shank) is not technically a sneaker.

The first shoes constructed with canvas uppers and vulcanized rubber outsoles were called “Sand Shoes.” These shoes were an evolution of a former sand shoe design that had a cotton canvas upper and outsole made from flat leather or jute rope. In the 1830s an English company called Liverpool Rubber evolved the original sand shoe, by bonding canvas to rubber, making the outsole more durable. The name “sand shoe” came from the fact that they were worn on the beach, by the Victorian middle class (Kippen 2004). Sand shoes were revolutionary as they replaced heavy and more expensive leather-work boots. Around the 1860s, a croquet shoe was created that had a rubber outsole with a canvas upper fastened with cotton laces. Sand shoes were different than the croquet shoe as they had a T-strap upper construction fastened with a metal buckle. Sand shoes were also the basis for traditional English school sandals, sometimes called “Sandies” (Wagner 1999).

In the 1870s, a more robust sand shoe was created; it was called a “Plimsoll” (also spelled Plimsol or Plimsole). The name came from Samuel Plimsoll (1824–1898), a British merchant and shipping reformer who designated the “Plimsoll Mark”—a mark on the hull of cargo ships that designated the waterline when it was at full capacity (*Britannica Student Encyclopedia* 2004). The term Plimsoll was adopted by the shoe industry because the point where the canvas upper and vulcanized rubber outsole bonded together looked similar to a ship’s Plimsoll line. This line aesthetically made the shoe look more expensive than previous models and became adopted by all social classes for a variety of athletic activities.

Around the same time the Plimsoll was popular in England, the term “sneaker” was coined in the United States. There are several cited origins and dates of the term. Some say the word is merely an Americanism, made from the word “sneak” (1870), because the shoe was noiseless (Coye 1986, pp. 366–369). There is also a reference that the noise-less rubber shoes were preferred by “sneak thieves” (1891) hence the name sneakers (Vanderbuilt 1998, p. 9). There is even a source that mentions the shoe got its name from “sneaky” (1895) baseball players who liked stealing bases in them (Hendrickson 2000). Many sources reference Henry Nelson McKinney (1917), an advertising agent for N. W. Ayer & Son. He came up with the name “sneaker,” because the rubber outsole allowed the shoe to be quiet or “sneaky” (Bellis 2004).

No matter how the name was born, shoes with a canvas upper and a vulcanized rubber outsole evolved into many forms. These evolutions allowed people to enhance their athletic skills and provided an aesthetic opportunity for casual shoe design. In the 1880s, vulcanized rubber was added to the toe box to stop the big toenail from breaking through the canvas. It also provided abrasion resistance in sports where the forefoot was dragged to provide balance (e.g., tennis). Functional outsole patterns (e.g., herringbone) were also created to add traction, facilitate player movements, and cushion the load when jumping. Similar types of shoes became useful for sailing and yachting, since they provided traction on the wet deck. The military also used them, and had them colored according to rank. Schools recommended them to students for gym class. Athletes wore them at the first modern Olympics in Paris (1900), and Robert Falcon Scott wore them on his Antarctic expedition (1901–1904) (Kippen 2004).

### Names

Since the creation of the sand shoe, there have been numerous names used globally to describe a shoe with a canvas upper and vulcanized rubber outsole. In the beginning, plimsoll and sneaker were popular names. Over time, a variety of other names have been created. Some are based on function, while others are based on materials, people, and even street slang. A few of the names include: Bobos, Bumper Boots, Chuck’s, Creepers, Daps, Felonies, Fish Heads, Go Fasters, Grips, Gym Shoes, Gymmers, Joggers, Jumps, Kicks, Outing Shoes, Pumps, Runners, Sabogs, Skiffs, Sneaks, Tackies, Tennies, Trainers, and Treads (Perrin 2004).

### Materials and Construction

Although athletes have been wearing performance-related footwear for thousands of years, the “sneaker” is only a recent creation based upon serendipity and adaptations of several industrial revolution inventions.

The most recognized feature of a sneaker is its vulcanized rubber outsole. Natural or India rubber, a by-product of trees, has been cultivated since 1600 B.C.E. (by

the Mayans). However, natural rubber “as is,” is not really appropriate for shoes. In hot and sticky weather it melts; in cold weather it becomes brittle and hard. In 1839, Charles Goodyear from the United States serendipitously created the modern form of rubber used for sneakers when he was trying to come up with a waterproof mailbag material for the U.S. government. Goodyear’s recipe, later named “vulcanization” was discovered when he accidentally dropped a mixture of rubber, lead, and sulfur onto a hot stove. His accident resulted in a substance that was not affected by the weather, and would snap back to its original shape when stretched (Goodyear 2003). The same type of rubber was reinvented and patented in England (1843), by a rubber pioneer named Thomas Hancock, who analyzed and copied samples from Goodyear. A friend of Hancock’s coined the term “vulcanization” after Vulcan, the Roman god of fire (Goodyear 2003).

### Sewing Machine

Cotton canvas was around for a long time before the creation of the first sneaker-type construction; however, sewing small pieces of canvas into a three-dimensional shape that conforms to the foot is quite tedious by hand. The lockstitch sewing machine was invented and patented in 1845 by Elias Howe, which allowed fabrics of all weights and constructions to be quickly and neatly stitched together. In 1851, Isaac Merrit Singer improved upon Howe’s invention (and also infringed on Howe’s patent), and started his own sewing machine business that still prospers among home sewers and clothing factories (Bellis 2004). Singer’s sewing machine was further evolved for the shoe industry by one of his own employees: Lyman Reed Blake. In 1856, Blake became a partner in a shoemaking company and was dedicated to inventing machines that helped automate the shoe-manufacturing process. In 1858, he received a patent for a machine that could stitch shoe uppers to outsoles. He sold his patent to Gordon McKay in 1859, and worked for McKay from 1861 until his retirement in 1874. The shoes made on this machine were known as “McKays” (United Shoe Machinery Corporation 2004).

### Lasting Machine

The sewing machine was helpful in automating the shoe-making process, but it was not the ultimate solution of joining an upper to an outsole. A typical sewing machine cannot manipulate around small, curvy parts that exist in a shoe design, and it takes great skill to bend, shape, and hold the upper while it is stitched to the outsole. American immigrant Jan Matzeliger (from Dutch Guiana) helped revolutionize the shoe industry by developing a shoe lasting machine that could attach an outsole to an upper in one minute. His shoe lasting machine was able to adjust an upper snugly over a last (a foot form used for shoemaking), arrange the upper under the outsole and pin it in place with nails while the outsole is stitched to



### SHOELACES

Before shoelaces, shoes were typically fastened with metal buckles. The shoelace (lace and shoe holes) was invented in England (1790). An aglet is the small plastic or metal tube that binds the end of a shoelace to prevent it from fraying. It also allows the lace to pass easily through the shoe’s eyelets or other openings (e.g., webbing/leather loops). The term “aglet” comes from the Latin word for “needle” (Bellis).

the upper. On March 20, 1883, the United States Patent Office awarded Matzeliger patent number 274,207 for his do-it-all shoe lasting machine (Tenner 2000, p. 37). The lasting machine revolutionized the shoe-making process as it could make hundreds of pairs of shoes a day and enabled the mass production of affordable shoes.

### Early Sneaker Marketing

There are hundreds of companies that produce sneakers for the global marketplace. The first sneakers were manufactured and marketed by rubber companies, as they were the major producers of vulcanized rubber.

**Dunlop Green Flash.** The Dunlop rubber company in England can trace their first marketed sneaker (plimsoll) back to the 1870s. In 1933, their Green Flash collection was launched and proved to be very popular. It had a higher quality canvas upper and a better outsole (with a herringbone pattern) to provide good traction on grass tennis courts. Dunlop’s Green Flash was worn by Fred Perry to win three Wimbledon titles (Heard 2003, pp. 290–291).

**U.S. Rubber Keds.** Keds was the first mass-marketed sneaker brand in the United States (1917), by U.S. Rubber. Much debate took place around naming U.S. Rubber’s sneaker, as the initial favorite was Peds meaning, “foot” in Latin. Unfortunately another company trademarked the name, so U.S. Rubber narrowed the name down to two other possibilities—“Veds or Keds.” Keds was chosen because the company felt that “K” was the strongest letter in the alphabet (Paquin). Another story says that the letter “K” represents the word “Kids,” and that Keds is rhyming slang for Peds—the name that U.S. Rubber originally wanted to use for their sneaker (Vanderbuilt 1998, p. 22).

**Converse Chuck Taylor.** In 1908, Marquis M. Converse from Massachusetts was producing rubber galoshes and decided that he would like a more exciting career. In 1917, he introduced the Converse All-Star, a high-top

sneaker designed especially for basketball. At the same time, Charles H. Taylor, a basketball player for the Akron Firestones, believed so much in Converse's shoe that he joined the sales force in 1921 and traveled across the United States promoting the All-Star Sneaker. He was so successful in promoting, selling, and making important changes to the original design that in 1923 his signature "Chuck Taylor" appeared on the ankle patch and the shoes were known as "Chucks" (Heard 2003, pp. 278–279). Converse's Chuck Taylor design is still popular around the world.

### Modern Sneaker Marketing

Once the basic processes were established to make and market sneakers, companies other than rubber manufacturers were founded. These companies evolved technologies and created competition in the marketplace. Some of the most influential companies are reviewed chronologically.

**Reebok.** In the 1890s, Joseph William Foster from Bolton, England made some of the world's first known track spikes. Although track spikes are technically different than sneakers, Foster was interested in making athletes run faster by evolving shoe technologies. By 1895, he was in business making spikes for an international circle of distinguished runners. In 1924, J. W. Foster and Sons made the spikes worn in Summer Olympic Games by the athletes celebrated in the film *Chariots of Fire* (Vanderbuilt 1998, p. 11). In 1958, two of Fosters' grandsons started a companion company named Reebok (which went on to make sneakers), after the African gazelle. Reebok has grown to be one of the world's largest athletic shoe manufacturers, producing products for many sports like tennis, basketball, and cross-training.

**New Balance.** Location was another commonality between the first sneaker manufacturers, as talent and machinery were important in keeping manufacturers in business. Most came from England or the New England region of the United States, particularly Massachusetts. New Balance was one of those companies, and was established in 1906, by William J. Riley from Watertown, Massachusetts. Riley was a 33-year-old English immigrant who committed to help people with troubled feet by making personal arch supports and prescription footwear to improve shoe fit. Arch supports and prescription footwear remained the core of New Balance's business until 1961, when they manufactured the "Trackster," a performance running shoe (weighing 96 grams) that was made with a rippled rubber outsole and came in multiple widths (Heard 2003, pp. 48–49). The Trackster was the preferred shoe of college running coaches and YMCA fitness directors. Since the 1960s, New Balance's reputation for manufacturing performance footwear in multiple widths has grown through word of mouth and "grassroots" marketing programs for which they are still known.

**Adidas.** The first major non-English or American sneaker manufacturers were the Dassler brothers, Adolf (nicknamed Adi) and Rudolf (nicknamed Rudi) who set-up business in Herzogenaurach, Germany (1926). Their first sneakers cost two German Reich marks, and followed three guiding principles: to be the best shoes for the requirements of the sport, to protect athletes from injury, and to be durable. The Dasslers developed many firsts in the athletic shoe industry. Some of them included shoes with spikes and studs for soccer, track, and field. They also looked at constructing shoes with materials other than leather and canvas to reduce weight. By 1936, the Dasslers' shoes were internationally known, and were worn by many great athletes like Jesse Owens. In the Berlin 1936 Olympics, Owens won in almost every track and field event he competed in, earning four gold medals while wearing the Dasslers' shoes (Cheskin 1987, p. 11). Due to irreconcilable differences, Adi Dassler parted from his brother Rudi (1948), and they formed two separate shoe companies (Vanderbuilt 1998, p. 29). Rudi's company was called Puma, named after the powerful wild cat. Adi's company was called Adidas, where he took the first two syllables of his first and last name to create the famous name for his product line. To give support to the runner's midfoot, Adi created the three side stripes trademark in 1949 which is still used in almost every Adidas athletic shoe design (Heard 2003, pp. 90–93).

**Onitsuka Tiger (ASICS).** Although most sneakers in the early 2000s are manufactured in Asia, Onitsuka Tiger (later named ASICS) was the first Asian brand to make a statement in the sneaker market. Established in Kobe, Japan (1949), by Kihachiro Onitsuka, the company's philosophy was based on "bringing-up sound youth through sports." Onitsuka believed that playing sports was a solution to keeping kids out of prison, especially after World War II. The company's first shoes were made in Onitsuka's living room and resembled the Converse All-Star. Another philosophy of Onitsuka's was "harmony between human and science." In an interview with Onitsuka, he said: "We try to analyze all phenomena which affect a human body during sports and to make shoes which will meet the needs of the users is our principle toward the shoe making" (ASICS 2004). The company's name evolved to ASICS in 1977 based on the Latin phrase "Anima Sana In Corpore Sano," which translates to "A Sound Mind in a Sound Body." Although ASICS is a smaller company compared to the others mentioned, it is important to note, as it inspired the creation of Nike. Nike's founders, Bill Bowerman and Phil Knight, started their careers in the sneaker business working for ASICS, where they designed, developed, and sold their products.

**Nike.** Of all the major sneaker companies, Nike is the youngest, yet the largest globally. Nike was a business venture between the track coach Bill Bowerman from the University of Oregon and Phil Knight (who ran for Bowerman). Bowerman always had a desire for better-



quality running shoes and was always tinkering with new ideas. He even made customized shoes for his own athletes. Bowerman was very inspirational to Knight, and while studying for his MBA at Stanford University in the early 1960s, he devised a small business plan for making quality running shoes, producing them in Japan, and shipping to the United States for distribution. After graduation, Knight traveled in 1963 to Japan to seek a way to live his dream. Representing Blue Ribbon Sports (BRS), he met with the president of Tiger ASICS (Onit-suka Company) and they agreed to go into business. Knight traveled throughout the West Coast of the United States and sold ASICS out of his car. Even Bowerman got involved and evolved some of the designs. Eventually the partners decided to split from the Onit-suka Company and create their own company. In 1971, Jeff Johnson (the first Nike employee) coined the name "Nike," and the Swoosh was created. The name originates from the Greek goddess of victory, and the famous Swoosh design was the creation of student Caroline Davidson, who was paid only \$35 (Nike 2004). The first Nike shoe to feature the Swoosh was the Cortez in 1972. Product innovation and marketing has been key to Nike's success. By the end of the twentieth century, technologies like the waffle outsole, AIR, SHOX and legacies like Michael Jordan and Tiger Woods were just a few things that contributed to making Nike the largest sneaker company in the world.

**Trainers.** Technically, a sneaker is a shoe made of a canvas upper and a soft rubber outsole. What some refer to as a sneaker is much different and a more correct term to use is "trainer" or "athletic shoe." Since the creation of the first sneaker-type construction, technology, fashion, and the desire for athletes to perform more efficiently and accurately have led to design evolution. The most typical types of sneakers are: running, cross-training, walking, basketball, and tennis. Technologies in materials have allowed sneakers to be made of synthetic leathers and 3D knits that are lightweight, breathable, and waterproof. A modern-day trainer could be as complicated as a shoe with an upper, midsole, insole, outsole, and shank. Within those parts, there are often subparts that better define each particular technology and give it its own specific performance advantage to others in the marketplace.

See also **Shoemaking; Shoes.**

#### BIBLIOGRAPHY

- Cheskin, Melvyn P. *The Complete Handbook of Athletic Footwear*. New York: Fairchild Publications, 1987.
- Coye, Dale. "The Sneakers/Tennis Shoes Boundary." *American Speech* 61 (1986): 366–369.
- Heard, Neal. *Sneakers: Over 300 Classics from Rare Vintage to the Latest Designs*. London: Carlton Books, 2003.
- Hendrickson, Robert. *Facts on File Encyclopedia of Word and Phrase Origins*. New York: Facts on File Inc., 2000.

Tenner, Edward. "Lasting Impressions: An Ancient Craft's Surprising Legacy in Harvard's Museums and Laboratories." *Harvard Magazine* 103, no. 1 (September–October 2000): 37.

Vanderbuilt, Tom. *The Sneaker Book: Anatomy of an Industry and an Icon*. New York: The New Press, 1998.

#### Internet Resources

- ASICS. "Special Interview: The Reasons Why I Keep Making Sports Shoes." ASICS Shoe History: Epochs of 1949–2000. Available from <[http://asics.cyplus.com/index\\_e.html](http://asics.cyplus.com/index_e.html)>.
- Bellis, Mary. "Footware and Shoes: What You Need to Know About." Available from <<http://inventors.about.com/library/inventors/blshoe.htm>>.
- Goodyear. "Charles Goodyear and the Strange Story of Rubber." Goodyear. Available from <<http://www.goodyear.com/corporate/strange.html>>.
- "The History of Your Shoes." Shoe Info Net. Available from <<http://www.shoeinfonet.com>>.
- Kippen, Cameron. "History of Sport Shoes." Curtin University of Technology: Department of Podiatry. Available from <<http://podiatry.curtin.edu.au/sport.html#science>>.
- Nike Inc. "Niketimeline: From Humbling Beginnings to a Promising Future." Nikebiz.com, The Inside Story. Available from <<http://www.nike.com/nikebiz>>.
- Paquin, Ethel. "From Creepers to High-tops: A Brief History of the Sneaker." Lands' End Catalog. Available from <<http://www.landsend.com>>.
- Perrin, Charles L. "Athletic Shoes: Many Types, Many Nicknames." Charlie's Sneaker Pages. Available from <<http://sneakers.pair.com>>.
- "Plimsoll Line." *Britannica Student Encyclopedia*. Encyclopedia Britannica Premium Service. Available from <<http://www.britannica.com>>.
- Wagner, Christopher. "School Sandals." Historical Boys Clothing (HBC). Available from <<http://histclo.hispeed.com/index3.html>>.

Susan L. Sokolowski

**SOCIAL CLASS AND CLOTHING** Display of wealth through dress became customary in Europe in the late thirteenth century. Therefore, a person's class affiliation could be assessed with relative ease. Because dress was recognized as an expressive and a potent means of social distinction, it was often exploited in class warfare to gain leverage. Dress was capable of signifying one's culture, propriety, moral standards, economic status, and social power, and so it became a powerful tool to negotiate and structure social relations as well as to enforce class differences.

For example, the sumptuary laws in Europe in the Middle Ages emerged as a way to monitor and maintain social hierarchy and order through clothes. People's visual representation was prescriptive, standardized, and

regulated to the minutest detail. The types of dress, the length and width of the garment, the use of particular materials, the colors and decorative elements, and the number of layers in the garment, for instance, were confined to specific class categories. However, after society's lower-class groups relentlessly challenged the class structure and evaded the sumptuary laws' strictures, the laws were finally removed from statute books in the second half of the eighteenth century.

The sartorial expression of difference in social rank is also historically cross-cultural. For example, in China, a robe in yellow, which stood for the center and the earth, was to be used only by the emperor. In Africa among the Hausa community, members of the ruling aristocracy wore large turbans and layers of several gowns made of expensive imported cloth to increase their body size and thus set them apart from the rest of the society. In Japan, the colors of the kimono, its weave, the way it was worn, the size and stiffness of the obi (sash), and accoutrements gave away the wearer's social rank and gentility.

### The History and Substance of Social Class System

Social class is a system of multilayered hierarchy among people. Historically, social stratification emerged as the consequence of surplus production. This surplus created the basis for economic inequality, and in turn prompted a ceaseless striving for upward mobility among people in the lower strata of society.

Those who possess or have access to scarce resources tend to form the higher social class. In every society this elite has more power, authority, prestige, and privileges than those in the lower echelons. Therefore, society's values and rules are usually dictated by the upper classes.

### Social Class Theories

Philosopher and economist Karl Marx argued that class membership is defined by one's relationship to the means of production. According to Marx, society can be divided into two main groups: people who own the means of production and those who do not. These groups are in a perpetual, antagonistic relationship with one another, attempting either to keep up or reverse the status quo. Sociologist Max Weber extended Marx's ideas by contending that social class refers to a group of people who occupy similar positions of power, prestige, and privileges and share a life style that is a result of their economic rank in society.

Social class theories are problematic for a number of reasons. They often conceptualize all classes as homogeneous entities and do not adequately account for the disparities among different strata within a particular social class. These theories also tend to gloss over geographic variants of class manifestations, such as urban and rural areas. A host of other factors, such as gender, race, ethnicity, religion, nationality, and even age or sexuality, further complicate the theories.

### Social Class in the Twenty-First Century

In the twenty-first century, assessing one's social class is no longer a straightforward task because categories have become blurred and the boundaries are no longer well defined or fixed. Now one's social class would be decided by one's life-style choices, consumption practices, time spent on leisure, patterns of social interaction, occupation, political leanings, personal values, educational level, and/or health and nutritional standards.

Since, in global capitalism, inter- and intra-class mobility is not only socially acceptable but encouraged, people do not develop a singular class-consciousness or distinct class culture. Instead, they make an effort to achieve self-representation and vie for the acceptance of their chosen peer group. The progress of technology has also helped provide access to comparable and often identical status symbols to people of different class backgrounds across the globe. At the same time, however, as sociologist Pierre Bourdieu argues in his treatise *Distinction* (1984), the dominant social classes tend to possess not only wealth but "cultural capital" as well. In matters of dress, this capital manifests itself in the possession of refined taste and sensibilities that are passed down from generation to generation or are acquired in educational establishments.

### Conspicuous Leisure, Consumption, and Waste

According to economist and social commentator Thorstein Veblen, the drive for social mobility moves fashion. In his seminal work, *The Theory of the Leisure Class* (1899), Veblen claims that the wealthy class exercised fashion leadership through sartorial display of conspicuous leisure, consumption, and waste. The dress of people in this group indicated that they did not carry out strenuous manual work, that they had enough disposable income to spend on an extensive wardrobe, and that they were able to wear a garment only a few times before deeming it obsolete.

*Imitation and differentiation: Trickle-down, bubble-up, and trickle-across theories.* Although sociologist Georg Simmel is not the sole author of the "trickle-down" theory, the general public still attributes it to him. In his article, *Fashion* (1904), Simmel argued that upper-class members of society introduce fashion changes. The middle and lower classes express their changing relationship to the upper classes and their social claims by imitating the styles set by the upper classes. However, as soon as they complete this emulation, the elite changes its style to reinforce social hierarchy. But as Michael Carter's research in *Fashion Classics* (2003) demonstrates, imitation and differentiation does not occur necessarily one after the other in a neat fashion. Instead, there is an ongoing, dynamic interaction between the two. Besides, within each class as well as among the different classes, there is an internal drive to express and assert one's unique individuality.

By the 1960s, the fashion industry had begun to produce and distribute more than enough products for everyone to be able to dress fashionably. This democratization of fashion means that by the twenty-first century anyone across the world could imitate a new style instantaneously. The direction of fashion change is no longer unilinear—it traverses geographical places, and flows from both the traditional centers of style as well as “the periphery.” Through global media and popular culture, members of the lower classes, and subcultural and marginal groups, have been able to influence fashion as much as those in the upper classes. Therefore, it has become more appropriate to talk about a “bubble-up” or “trickle-across” theory.

Although social class is no longer a significant category of social analysis, one remains cognizant of it. The display of one’s social standing through dress has become more subtle, eclectic, and nonprescriptive. The key to assessment in the early 2000s is often in the details. Higher status is indicated by a perfectly cut and fitted garment, the use of natural and expensive fabrics, and brand-name wear. One’s class affiliation is often given away only by the choice of accessories, such as eyeglasses, watches, or shoes. A stylish haircut, perfect and even teeth, and especially a slender body often have become more of a class signifier than dress itself.

See also **Gender, Dress, and Fashion.**

#### BIBLIOGRAPHY

- Bourdieu, Pierre. *Distinction*. Cambridge, Mass.: Harvard University Press, 1984.
- Carter, Michael. *Fashion Classics from Carlyle to Barthes*. New York: Berg, 2003.
- Crane Diana. *Fashion and Its Social Agendas*. Chicago: University of Chicago Press, 2000.
- Damhorst, Mary Lynn, Kimberley A. Miller, and Susan O. Michelman, eds. *The Meanings of Dress*. New York: Fairchild Publications, 1999.
- Davis, Fred. *Fashion, Culture, and Identity*. Chicago: University of Chicago Press, 1992.
- Kaiser, Susan. *The Social Psychology of Clothing*. New York: Macmillan Publishing Company, 1990.
- Simmel, Georg. “Fashion.” *International Quarterly* 10: 130–155.
- Veblen, Thorstein. *The Theory of the Leisure Class*. New York: Macmillan, 1899.

*Katalin Medvedev*

**SPACE AGE STYLES** Humans did not walk on the moon until 1969, but their imminent arrival was slotted on the world’s calendar from the very beginning of the decade. Space exploration’s grip on the popular consciousness during the 1960s contributed to a new fashion philosophy, becoming a pool of design inspiration; an analog to speculation about a radically transformed future that preoccupied the sensibilities of the decade. In

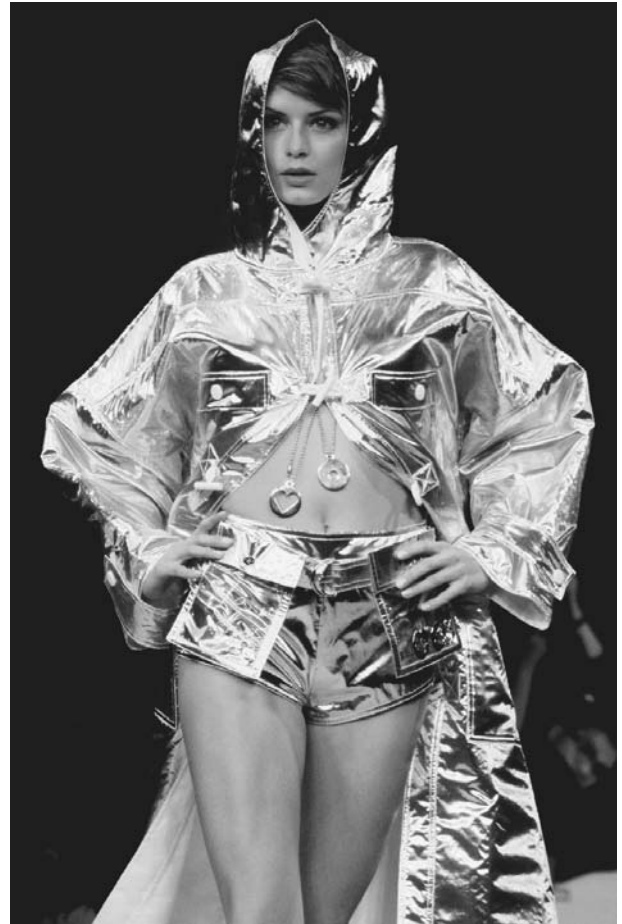

**Space age outfit.** A woman models an outfit from Andre Courrèges’s 1994 spring/summer collection. In the 1960s, Courrèges was instrumental in developing the sleek, shiny, aerodynamic look called space age. © PHOTO B.D.V./CORBIS. REPRODUCED BY PERMISSION.

the April 1965 issue of *Harper’s Bazaar*, Richard Avedon photographed British fashion model Jean Shrimpton wearing an astronaut’s helmet and flight uniform. But it was hardly necessary to don an actual flight suit to be part of the styles that came to be known as “space age.” Sleek as a fuselage, space age fashion emulated the aerodynamic simplicity and severity of a space capsule. Frills and flounces were eschewed in favor of a new, hard-edged and streamlined silhouette that also incorporated industrial materials. Space age fashion created a brusque and frequently shocking brave new universe within the 1960s fashion cosmos.

**Blast off.** As a design movement, space age fashion was above all a French phenomenon, promulgated mostly by men in their thirties who had been trained in the old-guard Paris couture, but saw the need to refute some of their pedigree. André Courrèges was perhaps the most creative. Courrèges was a member of Balenciaga’s couture house for ten years before beginning his own



business in 1961 in partnership with his wife Coqueline, who had also worked for Balenciaga. It took him but a couple of years to find his own feet, and when he did he kicked out the props from under establishment couture. “Things have never been the same since Courrèges had his explosion,” Yves Saint Laurent said in a 1966 *Women’s Wear Daily* (9 December, p. 1).

Before turning to fashion, Courrèges had dallied in both architecture and engineering, and this was reflected in his clothes. His dresses, suits, and trouser suits might be fitted, semi-fitted, or tubular, but they presented a bold and graphic silhouette, delineated as interlocking geometries by welt seaming and strategic piping. He preferred a restricted palette of monochromes and pastels, and was partial to aggressive checks and stripes. Courrèges used white a great deal, exploiting its myriad and contradictory connotations of sterility and/or purity as well as all-inclusive spectrum-spanning synergy.

Courrèges’s work surely owed a debt to London ready-to-wear, but ever present in his work was the active, constructing hand of the couturier. His fabrics were flat, tailored wools, more intractable than what ready-to-wear was espousing. In a Courrèges suit a woman herself became a Brancusi-like distillation, an avatar of streamlined strength. Courrèges inveighed against the traditional appurtenances of femininity and foreswore the curvilinear. Reaching his meridian in 1964 and 1965, he advocated very short skirts as well as pants for all occasions, at the time a highly controversial proposition.

**Women of the future.** “Working women have always interested me the most,” Courrèges said in *Life Magazine* in 1965. “They belong to the present, the future” (21 May, p. 57). Yet what he produced could not be easily transferred to the workplace, although his clothes and mass-manufactured imitations were seen on streets around the world. He offered what might be considered fashion manifestos. For him, high heels were as absurd as the bound feet of Asian women. He outfitted his models, instead, in flat Mary Jane slippers, or white boots that enhanced the graphic rectangularity of his silhouette.

After six years working for Balenciaga, Emanuel Ungaro assisted Courrèges for one year before opening his own doors in 1965. He also promised a radical departure from couture business-as-usual, pledging that there would be no evening clothes in this first collection, since he did not believe in them. He was certainly Courrèges’s disciple during these years but his suits and dresses in childlike flaring shapes were gentle and more ingratiating. Essential to the success of the young house as unique fabrics designed exclusively for him by his partner Sonia Knapp. Knapp worked as closely with Ungaro as Coqueline Courrèges did with her husband.

A decade older than Courrèges or Ungaro, Pierre Cardin began his own business in 1957 after apprenticeships at several couture houses. During the epoch of space age, Cardin offered some of the couture’s most

outré designs, offered like so much during the 1960s as provocative hypothesis rather than empirical prototype. His shapes might resemble floral abstractions that devoured conventional clothing dimensions. His enormous collars and frequent use of vinyl evoked outer-space gear. Cardin was a Renaissance man whose many endeavors included his own theater. Both Courrèges and Ungaro established ready-to-wear and licensing franchises, but Cardin’s endeavors were waged on an exponential scale. His empire included a highly successful men’s wear line—“Cardin’s cosmonauts” presented a complementary vision of men’s apparel.

Like much of Cardin’s ideas, Paco Rabanne pushed space age fashion toward wearable art. He too trained as an architect, then designed accessories, before the young designer created a sensation in 1966 with ready-to-wear sheaths of plastic squares and discs attached to fabric backing. They were *le dernier cri* of Paris fashion, memorably commemorated in William Klein’s film of the same year, *Qui Etes Vous Polly McGoo*. For him the new and ultimate frontier of fashion had become “the finding of new materials.” His investigation of plastics and other hardware as possible human carapaces proclaimed a new epoch in Paris’s wonted tradition of clothes so intricately constructed that they could stand on their own.

Space age fashion was gestated in a salon environment that was just as stark and unadorned as the clothes. New-style fashion shows went hand in hand with the fashion experiments they showcased. They were hectic rather than stately, built around mysterious theatrical effects rather than the old-style hauteurl.

**Splashdown.** In the early 2000s, space age styles seem a paradigm of the teleological mentality of the 1960s, a last glorification of industrialization before the realization of its downside. Hard-edged fashion stayed influential all through the 1960s, eventually being vanquished by the unconstructed fashion that prevailed during the first half of the 1970s. The leaders of space age fashion have all remained in vogue, and from time to time pay homage to their bellwether work of the 1960s.

See also **Extreme Fashions; Futurist Fashion, Italian.**

#### BIBLIOGRAPHY

Lobenthal, Joel. *Radical Rags: Fashions of the Sixties*. New York: Abbeville Press, 1990.

Ryan, Ann, and Serena Sinclair. “Space Age Fashion.” In *Couture*. Garden City, N.Y.: Doubleday, 1972.

*Joel Lobenthal*

**SPACE SUIT** While there have been many different ensembles of clothing worn by astronauts, the term “space suit” generally refers to the total life-support system for Extra-Vehicular Activity (EVA) that takes place outside the shelter of the spacecraft. The extreme conditions of

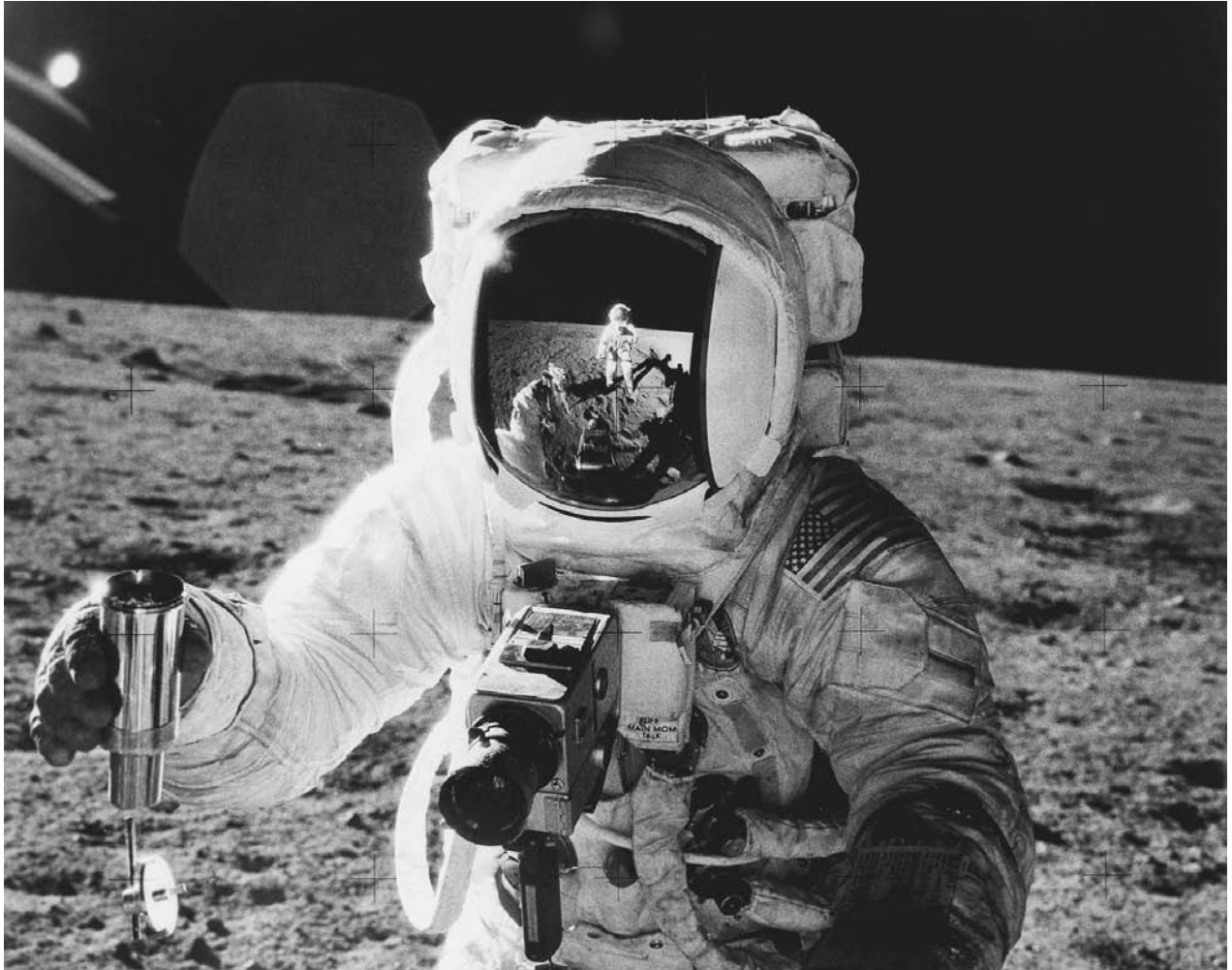

**Apollo 12 astronauts.** Astronaut Alan Bean holds up a sample of lunar soil during the *Apollo 12* mission. Commander Charles Conrad can be seen reflected in Bean's visor. The space suits used by the *Apollo* astronauts were custom-made for each astronaut and were the first suits capable of operating with a portable life support system, freeing astronauts from physical connection to a space ship. © BETTMANN/CORBIS. REPRODUCED BY PERMISSION.

outer space demand ensembles for EVA that are among the most complex clothing items ever designed.

### Hazards of Outer Space

There are a variety of environmental conditions in outer space that humans cannot survive. Temperatures on the moon, for example, range from +250° F. to -250° F. (+121° C. to -157° C.). These temperature extremes are experienced instantly, as one moves from sunlight into shade. Astronauts are exposed to cosmic rays and charged particles from the sun. There is little filtration of ultraviolet light, so they must also have significant protection for their eyes.

The absence of atmosphere means that there is neither oxygen for breathing nor atmospheric pressure to keep body tissues intact. Without at least a portion of the pressure of the Earth's atmosphere on the body, its flu-

ids begin to boil and migrate outward. When unprotected a person becomes unconscious in 15 seconds, with death quickly following.

Finally, micrometeoroids are small particle-like grains of sand that travel at great rates of speed. These pose the threat of suit puncture and the risk of loss of pressure.

### Early Space Suits

Most space suits comprise many layers of fabric, grouped to serve three basic functions: (1) application of pressure, (2) thermal and impact protection from the environment, and (3) thermal and general comfort. Accessories add breathing air, abrasion protection, vision protection, and communications tools.

The precursors to the space suit, the pressure suits worn by high-altitude pilots, focused almost exclusively on one function: application of pressure. In 1934, Wiley

Post developed the first pressure suit as a practical alternative to pressurizing his plane. His suit was pressurized with pure oxygen, which also provided him with breathing air, and was shaped to his position in the cockpit. As with several generations of suits that followed, it was almost impossible to move in Post's suit once it was inflated.

The first true space suits, worn by astronauts in the Mercury program in 1961, provided air for breathing and cooling and allowed for emergency inflation in case the pressurization of the spacecraft failed. Using inflation only as an emergency measure solved the movement problems created by Post's suit. The Mercury suits also had an outer layer of aluminized Mylar for thermal protection.

When a walk outside the spacecraft was planned for the Gemini program in 1962, it became clear that a new suit design was needed. Astronauts would need more mobility and greatly increased thermal and micrometeoroid protection. A specially constructed "link-net" fabric covered the suit's "bladder" layer, the inflated neoprene suit used for pressure to keep the suit from ballooning. This made it easier for astronauts to move. For thermal and micrometeoroid protection, the Gemini suits relied on high-temperature nylons and nonflammable metals, with the outermost layer of the Gemini IX pants being made of a woven stainless steel. Gemini suits were air-cooled using umbilical cords that tethered astronauts to the spacecraft. The astronauts complained that these suits were too warm and reported that the air fogged their helmet visors.

### The Apollo Suits

The EVA ensemble for the Apollo moonwalk in 1969 included a number of new features: gloves with rubberized fingertips; overboots for abrasion protection; and extra visors for eye protection. To increase thermal comfort, a Liquid Cooling and Ventilation Garment (LCVG) was used. It consisted of a stretchable bodysuit with cooled water circulating in tubing covering a major portion of the body. Excess body heat was conducted to the water in the tubing, then cooled and recirculated. A backpack, the Portable Life Support System (PLSS), enabled the astronaut to travel in outer space entirely without connection to the spacecraft.

The Thermal Micrometeoroid Garment (TMG), which covered the Apollo suit, provided protection from puncture and temperature extremes. It incorporated multiple layers of fabrics, many of them aluminized with spacers (noncollapsible structures that incorporated many protected air spaces) in between them. The outer layer was made of Teflon-coated Beta Fiberglas, which was resistant to ignition and melting.

Molded rubber constant-volume bellows joints at the shoulders, elbows, hips, and knees greatly improved mobility over earlier suits. The entire EVA ensemble weighed 180 pounds (82 kg) on Earth, but only 30 pounds (14 kg) in the moon's gravity. This basic Apollo space-suit was also used for space walking during the Skylab missions.

### Designs for the Future

The unique goals for the Shuttle missions were reflected in the Shuttle space suit, the Extravehicular Mobility Unit (EMU). The EMU was not custom-made or designed to be used on a single mission, as were previous suits. The upper torso, lower torso, arms, and gloves were manufactured in different sizes that could be assembled to fit almost any body size and shape. Suits were designed to last for fifteen years and many missions. The EMU weighed almost twice as much as the Apollo EVA suits, but this was acceptable since they would be used in microgravity rather than within the gravitational pull of a planet. The outer layer of the Shuttle suits was an *ortho* fabric—a blend of Teflon, Nomex, and Kevlar fibers in a unique weave. This covered seven layers of aluminized materials in the TMG rather than the fourteen used for Apollo suits.

Another new feature of the Shuttle EMU was its Hard Upper Torso Assembly (HUT), a rigid fiberglass shell on which the backpack was mounted. Fabric arm and lower torso coverings and a rigid helmet were joined to the HUT with rigid bearing joints. Similar rigid structures are seen in designs for future space missions, such as one to Mars, for which completely rigid hard suits, much like deep-sea diving suits, have been developed. These suits are purported to allow greater ease of movement, and be more durable, lighter-weight, and easier to don than previous space suits.

See also **Techno-Textiles**.

### BIBLIOGRAPHY

- Harris, Gary L., ed. *The Origins and Technology of the Advanced Extra-Vehicular Space Suit*. American Astronautical Society History Series, Vol. 24. San Diego: Univelt, Inc., 2001.
- Joels, Kerry M., and Gregory P. Kennedy. *The Space Shuttle Operator's Manual*. New York: Ballantine Books, 1982.
- Kozloski, Lillian D. *U.S. Space Gear: Outfitting the American Astronaut*. Washington, D.C.: Smithsonian Institution Press, 2000.
- Mohler, Stanley R., and Bobby H. Johnson. *Wiley Post, His Winnie Mae and the World's First Pressure Suit*. Washington, D.C.: Smithsonian Institution Press, 1971.
- Watkins, Susan M. *Clothing: The Portable Environment*. Ames: Iowa State University Press, 1995.

Susan M. Watkins

**SPANDEX.** See **Elastomers**.

**SPANGLES** Spangles, also known as sequins or *paillettes*, are small, flat, circular ornaments usually made of metal, metallicized plastic, or other light-reflecting materials. Their primary use is to embellish apparel and accessories. Whereas beads are three-dimensional, spangles are essentially two-dimensional and can be overlapped to produce linear patterns.



The word “sequin” derives from the name of a small gold coin, the *zecchino*, which it resembles. The *zecchino* was introduced in Venice in 1284. *Chequeen*, a variant of the word, appeared in the English language in the late 1500s. By the nineteenth century, the word “sequin” was preferred to “spangle.”

Historically, spangles, (which were once also known as “oes,” because of their shape) were made by twisting gold or silver wire around a thin metal rod. The metal rings were cut off and hammered flat, resulting in a circular object with a central hole used to stitch it in place. In the 1920s, sequins were sometimes made of gelatin. In the twenty-first century, they are stamped out from plastic sheeting.

Spangles were a popular form of embellishment for the clothing of the aristocracy from the sixteenth through the eighteenth century. A host of sumptuary laws governing the dress of all classes of society prevented their being worn by anyone not of the nobility. In the seventeenth century, spangles were used to decorate men’s and women’s bodices, gloves, and shoes, as well as embroidered boxes and other decorative household items. In the eighteenth century, they appeared on muffs, shoes, women’s gowns, and on men’s coats and waistcoats. In the nineteenth century, sequins were still seen on court dress but they were also available to the general population. In the twentieth century, a craze for sequined “flapper” dresses emerged briefly during the 1920s. In the twenty-first century, sequins use in the apparel industry is primarily confined to womenswear and to the entertainment industry.

While other contemporary light-reflecting materials such as Lurex offer competition, designers including Norman Norell, Bob Mackie, and Carolina Herrera have used, and continue to use, sequins to produce eye-catching, shimmering evening wear.

See also **Mackie, Bob; Norell, Norman.**

#### BIBLIOGRAPHY

- Campbell, R. *The London Tradesman*. London: T. Gardiner, 1747. Reprint, Newton Abbot, England: David and Charles, 1969.
- Rivers, Victoria Z. *The Shining Cloth: Dress and Adornment that Glitters*. London and New York: Thames and Hudson, Inc., 1999.

*Whitney Blausen*

**SPANISH DRESS** A reliable overview of the history of Spanish dress from the Middle Ages to the twenty-first century, including its borrowings from and impact on the dress of other cultures, remains to be written. The subject is complex because of the internal make-up of the country, the multicultural society that spawned and epitomized the great Spanish empire of the early modern pe-

riod, and constant shifts in Spain’s political and economic relationship with the rest of the world. A large if sparsely inhabited country, located on the most southwestern periphery of Europe, Spain embraces a variety of regional identities that owe much to differences in climate, geography, and language, and to a rich historical legacy. Spain has been a country of contrasts: partially occupied by the Moors for more than 700 years, it experienced the cohabitation (*convivencia*) of different faiths (Jewish, Muslim, and Christian) until 1492; from that date it became the consistent, vociferous and sometimes intolerant champion of Catholicism, a nation state that experienced its Golden Age in the sixteenth and seventeenth centuries. Its massive empire, acquired through inheritance of lands in the southern Netherlands and Italy and the forceful occupation of colonies in the Americas, Asia, and Africa, brought great wealth and power in world affairs until the early seventeenth century. As both gradually dwindled, Spain turned into “marginal Europe,” modernizing only from the 1960s onward during the dictatorship of General Francisco Franco (1939–1975), and selling its cultural products, notably film and fashion, beyond its own frontiers and former colonies on an unprecedented scale since the 1980s.

The Spanish climate has lent itself to the cultivation of a wide range of raw materials for textile production, and skills in craft production have long been nurtured. Industrialization, having begun early, lagged behind that of northern Europe, and mass-production of clothing only took off gradually during the twentieth century. In the Middle Ages wool from the plains of Castile was much prized domestically and exported widely; flax (for fine and not-so-fine linens) grew plentifully in the damp climate of Galicia, and the Moors enriched Andalusia and Valencia by introducing sericulture and silk weaving. First of the peninsula, from the sixteenth century onward, the Spanish colonies supplied exotic dyestuffs, which delivered brilliant reds and the deepest blacks, colors that still inform the Spanish palette in ecclesiastical, regional, and fashionable dress. Weaving was well established by the Middle Ages, while knitting arrived by the thirteenth century, possibly introduced to Europe by the Moors via Andalusia. Spain became mechanized during the nineteenth century, while skills such as embroidery and leatherwork survived as prized handicrafts up to the present day.

#### Dress with a Difference

In the Middle Ages, Spain divided into Christian and Muslim zones, and hosted a variety of dress styles whose terminology and cut from the tenth century onward reveal a debt to Arab materials and garb—even in the Christian kingdoms. The contents of the tombs of the thirteenth- and early fourteenth-century kings of Castile in Burgos, for example, include mantles, surcoats, and tunics made of silks brocaded in northern taste with heraldic devices, such as the lions and castles of León and Castile, while the coffins are lined with silks with



## COMMENTARY BY FOREIGNERS VISITING SPAIN

**Mid-Sixteenth Century**

"The women generally wear black, as do the men, and around the face they wear a veil like nuns, using the whole shawl (*manto*) over the head. And when they do not wear the veil over the face, they wear high collars with huge ruffs; and they use [excessive] makeup...."

Camilo Borghese in 1594 on a visit to Madrid, (cited in *Garcia Mercadal*, p. 112)

**Mid-Eighteenth Century**

"Women of all ranks wear their rosaries in their hands whenever they go to church, and always in such manner that every body may see them. They are a part of their church-dress. I am told that it is customary, amongst the lower ranks, for the young men to present fine rosaries to their sweethearts. Women

of whatever condition never go to church but with the *basquiña* and the *mantilla* on. The *basquiña* is a black petticoat, commonly of silk, which covers their gowns from the waist down, and the *mantilla* is a muslin or cambric veil that hides their heads and the upper part of their bodies. If they do not turn up their veils, as some of them will do both at church and in the streets, it is difficult, if not impossible, even for husbands to know their wives" (Bareti, p. 421).

**Mid-Twentieth Century**

"... striking ... are the differences in regional costumes. Except for the familiar Andalusian costume of high comb, mantilla, sleeveless bodice, and wide flounced skirts with large white spots, it is safe to say that nearly all Spanish regional costumes clearly reveal Moorish influence" (Bush, p. 69).

Islamic patterns—stylized vegetation, geometric motifs, stars, zigzags, and inscriptions in Arabic script. By the eleventh century the pilgrimage route across the north of Spain to Santiago de Compostela connected Spain with neighboring Europeans consistently and by the middle of the fourteenth century, the Spanish aristocracy and urban elite were wealthy enough to change styles in clothing regularly, enriching their wardrobes with fashions from Burgundy and Italy. The accession of Charles I (son of Philip of Burgundy) to the Spanish throne in 1516 sealed Spain's intimate relationship with both states and introduced the austere black and white dress so familiar from portraits of Spain's Golden Age: this formal dress (*gala negra*) was accessorized with lavish gold chains, buttons, and jewelry wrought from the precious metals from the Spanish-American colonies. The Spanish monopoly on logwood, a black dyestuff also imported from the new colonies, may well have had some bearing on this urban predilection for the color, as well as the devout Catholicism of subsequent monarchs (especially Philip II, III, and IV and Charles II) who, to some extent, eschewed overbearing ostentation. Nonetheless, descriptions of festivities throughout the sixteenth and seventeenth centuries show that on holidays, those who could afford to do so often wore brightly colored garments of silk that were embroidered, brocaded, or trimmed in silver or gold. Spanish sumptuary laws made serious attempts to limit excess in the consumption of luxuries and to codify the distinctions between noble and bourgeois in the interests of protecting the Spanish economy and Spanish morals. References to the appropriate dress for Christian and non-Christian, promulgated in

the first laws from 1252 onward, ceased after the expulsion of Jews at the end of the fifteenth century and Moors at the beginning of the seventeenth century. Throughout this period, such laws were of little relevance to the poor and marginalized who wore inexpensive undyed cloth in tones of brown, gray, or off-white. They thus earned the epithet "people of brown clothes" (*gente de ropa parda*), which instantly differentiated them from their social superiors (*gente de ropa negra*).

**The Golden Age**

Significantly, during this Golden Age, when Spain was wealthy and powerful, and the literary and plastic arts flourished, the king's censors approved the publication of the first Spanish manuals devoted to disseminating superior skills in tailoring. The first book, published in 1580 and reprinted in 1589, came from the plume of a Basque tailor, the second in 1617 from a Frenchman turned Valencian, the third in 1640 from a father and son from Madrid—in other words, representatives of all major regions. These books convey the shifts in Spanish fashions and allegiances over the period, and the requirements of the upper and educated echelons of society. Consisting of patterns for men's and women's fashionable garments, mourning dress, clerical garb, robes for the military orders of Santiago and Calatrava, horses' caparisons and military banners, they reveal that most garments were Spanish in origin. The late sixteenth-century examples of Moorish and Italian gowns encountered Hungarian and French suits in the later work of Anduxar (1640)—a sign of royal alliance through marriage to Hungary and of the rise of French fashions, slimmer in silhouette than their

Spanish counterparts. Change in cut demonstrated the gradual isolation of Spanish noblemen from their European peers as their highly influential dress composed of doublets, jerkins, trunk hose, and cloaks of various lengths gave way to the rather singular padded breeches (*calzones*) that made Spaniards look broad and solid in comparison with their northern peers. At around the same time, Spaniards' crinkly white ruffs (*lechuguillas*) ceded pride of place at men's necks to the *golilla*, a plain white semicircular collar built on a base of cardboard. Both forms of neckwear performed much the same function, as did their matching cuffs, preventing hard manual labor and in the case of the former keeping heads high and haughty. Women of the upper classes were similarly constricted: decked out in impressive jewelry, they wore richly patterned gowns with bell-shaped skirts over the Spanish farthingale (*verdugado*), a cage-like underskirt constructed of bands of willow. This item of clothing appeared in the 1470s and underwent several changes in shape thereafter, reaching enormous proportions between the late 1630s and 1670s. In its early manifestation it found its way into the fashions of neighboring states, while later it merely demonstrated Spanish distance from the mainstream.

Other aspects of Spanish dress that were constants in the urban landscape were the robes of clergy and members of religious orders, the voluminous mantles worn by women in the streets to cover themselves up (a sign of modesty evidently inherited from Moorish dress), and the addiction to all-enveloping mourning garments. Not only was black the color of formal court dress, but many of these items also had religious and moral connotations even into the third quarter of the twentieth century: the clergy and the bereaved were a particularly potent provincial and urban presence, especially among the white, sunlit villages of the south.

### Dominance of Foreign Fashions

From about 1700 until the mid-twentieth century, the Spanish cognoscenti depended on Parisian (and sometimes British) modes. In the eighteenth century, under the ruling Bourbon dynasty, Spain received fashion news consistently from Paris via Spanish and French intermediaries—the powerful shopkeepers of the *Cinco Gremios Mayores*, ambassadors and well-traveled aristocrats, manufacturers' agents, the burgeoning French fashion press, and French emigrant dressmakers who set up businesses in the Spanish capital (as in other European cities). From the second half of the nineteenth century, wealthy female consumers and the most prestigious Spanish dressmakers made the annual or biannual pilgrimage to Paris to attend the haute couture shows, from which they acquired models for themselves or to adapt for their middle-class Spanish clients. In the major fashionable shopping centers of Madrid (center of government), Barcelona (heart of cotton and woolen production), and San Sebastián/Donostia (summer retreat of the court), by

the beginning of the twentieth century there was a host of major dressmaking establishments whose reputation did not transcend national boundaries (such as Carolina Montagne, María Molist, El Dique Flotante, Santa Eulalia, Pedro Rodriguez, and Carmen Mir). In men's dress, reliance on Spanish tailors continued although the wave of Anglomania that hit France in the late eighteenth century extended to Spain. This legacy may even have carried over into the twentieth century: the first Spanish dictator, José Primo de Rivera, ordered clothes from Savile Row prior to his espousal of a politically sensitized form of dress; Cristóbal Balenciaga, a skilled tailor, chose England in 1935 as his first destination before moving to Paris; and Spain's only department store, founded in 1935 as a tailoring outlet with a line in ready-made children's clothes, still carries the name *El Corte Inglés* (English cut).

The fashion press played its part in disseminating fashionable styles. While those who could afford high-class fashions probably read French publications, printed matter in Spanish was available from the early nineteenth century. It owed much to its French or northern European models: fashion plates remained the same while captions were translated into Spanish (in the early nineteenth century Rudolph Ackerman's *Repository for the Arts* received this treatment; in the 1830s and from the 1880s respectively, the *Semanario Pintoresco Español* and *El Salón de la Moda* followed a similar procedure). In the twentieth century, *El Hoga y Moda* from 1909, the *Boletín de la Moda* from 1952, and *Telva* from 1963 represented national production. These journals dispersed styles to local, small-scale professional dressmakers and their amateur counterparts (home-dressmakers). Indeed, sewing and knitting skills probably thrived longer in Spain than in wealthier, industrialized European states where ready-made clothing was widespread and traditional roles for women were called into question earlier. The continued presence of the church as patron and educator of needlework skills and morals probably contributed to keeping these traditions alive until the end of the twentieth century.

### Regional Dress

Despite the dominance of mainstream European fashions in the eighteenth and nineteenth centuries, and a noticeable rejection of traditional mores from the 1960s as large numbers of young Spaniards moved from rural areas into the cities, regional dress survived, often preserved carefully for use at national or local fiestas (religious holidays) and rites of passage such as marriage. It is still commissioned and made in the early 2000s for special occasions. Such dress has always varied by region, its materials and form relating to local textile supplies, agricultural activities, and calendar. Anthropologists have identified three main types by zone—north and Cantabrian, central, and Andalusian-Mediterranean—but they are still far from completing a comprehensive study. In the north and center, woolens and linens dominate festive dress; sometimes decorated with bands of silk or embroidery, the colors are



often deep (brown, black, and red or green), and heavy jewelry is common. In the south and east, gloriously colored silks, cottons, and linens flourish in the sun, accessorized with lace or transparent veiling often with a flash of metallic thread, a heady reminder of the legacy of the Moors. Such dress, although not immune to change over the centuries, is a fossilized version of earlier fashionable, festive, or working dress. While many of its features have their roots in the eighteenth century, some go much further back, and others date to more recent times. In Valencia, silks with eighteenth-century designs are still woven to satisfy the demand for festive dress comprising full, ankle-length skirts, worn with a tight-fitting bodice over a chemise and below a neckerchief and lace mantilla. Bullfighters' suits of lights (*trajes de luces*) fall into this category, their most obvious roots in popular Andalusian *majo* attire of the eighteenth century, worn at the time that the sport commercialized. The short jacket with braiding covering its seams harks back to seventeenth-century practices in tailoring, while the knitted net hairpiece (*redecilla*) so familiar from Francisco Goya's paintings located its wearers among the popular classes. The tight-fitting breeches or pantaloons belong to late eighteenth- or early nineteenth-century fashionable men's dress.

The exchange between fashionable and regional dress works both ways: at the end of the eighteenth century, certain aristocrats and Queen María Luisa herself adopted a version of Andalusian *maja* dress, the black lace mantilla and overdress, secured by bold red or pink sash; in the work of twentieth century and contemporary Hispanic fashion designers regional variations are often a leitmotiv. Cristóbal Balenciaga (1895–1972) and Antonio Canovas del Castillo (1913–1984), who made their reputations outside Spain through austere modernist designs, provided bursts of Spanish drama in their many flamenco-inspired dresses, even once they were resident in Paris. The picturesque qualities of such gowns were no doubt familiar (and possibly desirable) by then to the many foreign tourists who visited the Costa Brava, Costa Blanca, and Costa del Sol in growing numbers from the 1950s onward. Regional dress, sentimentalized as a symbol of a lost golden age with superior values since the nineteenth century, has also served an overtly political function: following the Civil War (1936–1939), the right-wing Falangist party encouraged the celebration of regional festivities and the wearing of regional dress in the interests of promoting national cohesion and identity (much as the Nazis did in Germany and the Vichy government in France).

### A New Golden Age?

Spanish dress may inadvertently have reached beyond Spanish frontiers before the 1980s via the acquisitions of tourists at the establishments advertised in tourist guides to Spain, via the creations of those Spanish couturiers who sought a propitious environment for their creativity in Paris, and via limited coverage in high-class fashion

magazines such as *Vogue*. It is only since the mid-1980s or so, however, that Spanish designers and clothing companies have marketed their wares abroad on a significant scale. Spanish government initiatives probably played some role in this drive although the industry is still relatively undercapitalized and undeveloped. In the early 1980s the socialists began with the revitalization of the textile industries, and by the middle of the decade turned their attention to the clothing sector. In 1985 they established the Center for the Promotion of Design and Fashion (CPDM) under the auspices of the Ministry of Labor and Energy, and in 1987, the Cristóbal Balenciaga prize that recognizes annually the achievement of the best Spanish designer, the best international designer, the best textile design company, and the best new designer. Subsequently, exhibitions of Spanish fashion brought design into the public eye: in 1988, *Spain: Fifty Years of Fashion* held in Barcelona; in 1990 *Spanish Designers* held in Murcia; and the projected opening of a fashion museum and research center in Guetaria received government backing of \$3.2 million in 2000. An elite group of fashion designers has emerged: they are known on the international catwalk as well as at the equivalent national events (Gaudí in Barcelona and Cibeles in Madrid), and they have outlets worldwide (such as Sibylla, Adolfo Domínguez, Pedro del Hierro, Antonio Miró, Purificación García, and Roberto Verino, to name a few). Even more impressive is the forceful, expanding ready-to-wear sector, notably the retailers Cortefiel and Loewe (both established in the late nineteenth century), Pronovias (the first company to provide ready-to-wear wedding dresses in Spain from the 1960s), and Mango and Zara, notorious internationally for its rapid reproduction of catwalk fashions. The expansion of their shops worldwide demonstrates the growth of these young empires: between 1964 and 2003, Pronovias opened 100 shops under its own name in Spain, one in Paris, with one in New York in the pipeline. It also distributes its goods through 1,000 multibrand shops in more than 40 countries, having diversified into cocktail wear and accessories. Zara, the original firm from which the Galician Inditex group grew, opened its first store in A Coruña in 1975, its first stores outside Spain (in Portugal, United States, and France) in the late 1980s, by 2000 had 375 stores worldwide, and only one year later more than 600. Barcelona-based Mango entered the arena in 1984 in Spain, expanded gradually in the following decade, and exponentially from the 1990s onward, boasting a total of 630 shops in 70 countries by 2002. The manufacturing base of these firms is located in the traditional textile manufacturing areas of Galicia and Catalonia.

Although these empires have grown quickly and, significantly, have flourished since the late 1980s, it is difficult to measure their impact on Spanish consumers who have access to all the top international brands in their major city centers and probably mix and match such brands with the Spanish newcomers, as fashion magazines

recommend (indigenous *Dunia* between 1978 and 1998, and *Telva* since 1963 and Spanish language editions of *Cosmopolitan*, *Elle*, *Vogue*, *GQ* since 1976, 1986, 1988, and 1993 respectively). It is not always possible to detect overtly Spanish features in products intended to sell in the global market and Spanish consumers are anxious to espouse a broadly fashionable appearance, like their counterparts in neighboring France and Italy. The kind of personal expression typified by the sub-cultural styles of northern Europe seems absent from Spanish streets. Increasing wealth and new professional opportunities and lifestyles for women may have boosted demand for fashion. In 1989, the CPDM published a survey on the changing habits of Spanish consumers since the mid 1980s. The findings suggested that there was an acute awareness of and pride in Spanish fashion, whose variety of styles and different price ranges competed with other European goods—even young consumers who aspired to American styles could create them through buying Spanish. Designer clothes were no longer reserved for special occasions but were now worn for everyday wear. Eleven years later, a Galician sociologist noted the correlation between lifestyle, social class, and choice of dress: the professional and educated classes in Spain aspired to follow seasonal fashion and conform to a recognizable “correct” appearance; they shopped in city center designer stores. The classic suit remained the main preference for both sexes. The epitome of this awareness of and national pride in domestic designer products must surely be the addition to the credits at the end of the Spanish national news on television of the name of the designer of the presenter’s clothes—all too often, it is Adolfo Domínguez, the doyen of classic, unstructured tailoring and a color palette of black, gray, and aubergine. This second Golden Age of Spanish fashion has surely inherited features from its august forebear.

See also **Ethnic Style and Fashion; Europe and America: History of Dress in (400–1900 C.E.)**.

#### BIBLIOGRAPHY

- Alcega, Juan de. *Tailor's Pattern Book 1589*. Facsimile, with translation by J. Pain and C. Bainton. Introduction and notes by J. L. Nevinson. Bedford, U.K.: Ruth Bean, 1979. A translation accompanies this facsimile edition of the second edition of the first Spanish publication on tailoring, as does an excellent introduction on the context for tailoring in sixteenth-century Spain.
- Anderson, Ruth Matilda. *Spanish Costume: Extremadura*. New York: Hispanic Society of America, 1951. Fieldwork undertaken in this region of Spain allowed Anderson to document the state of regional dress in this area in the late 1940s.
- . *Hispanic costume, 1480–1530*. New York: Hispanic Society of America, 1979. The most comprehensive and well-illustrated account of Spanish dress of this period, it follows the format of Bernis’s writing, identifying particular garments in paintings, and providing a useful explanation of terminology.
- Baretti, J. *A Journey from London to Genoa through England, Portugal, Spain, and, France*. Vol. 1, Letter 56. Madrid, 9 Oct. 1760.
- Berges, Manuel, et al. *Moda en Sombras*. Madrid: Museo Nacional del Pueblo Español, 1991. This catalogue accompanied an exhibition of the museum’s collection of regional and fashionable dress dating from the eighteenth to twentieth centuries. Seven excellent introductory essays are devoted to different aspects of regional and fashionable dress and its production and consumption in Spain over that period.
- Bernis Madrazo, Carmen. *Indumentaria medieval española*. Serie Artes y Artistas. Madrid: Instituto Diego Velázquez del Consejo Superior de Investigaciones Científicas, 1955.
- . *Indumentaria española en tiempos de Carlos V*. Madrid: Instituto Diego Velázquez del Consejo Superior de Investigaciones Científicas, 1962.
- . *Trajes y Modas en las España de los Reyes Católicos*. Serie Artes y Artistas. Madrid: Instituto Diego Velázquez del Consejo Superior de Investigaciones Científicas, 1978.
- . *Trajes y tipos en el Quijote*. Madrid: El Viso, 2001. These seminal accounts of the characteristics of dress in Spain from the Middle Ages to the early seventeenth century, offer a brief historical background to changing styles, identify the terminology in use, and the garments to which it applies through details from different works of art, from manuscripts to paintings and sculpture, and in the most recent volume concentrates on a single literary source.
- Bush, Jocelyn. *Spain and Portugal*. Fodor’s Modern Guides. London: Newman Neame Limited, London, 1955.
- Carbonel, Danièle, after text by Pedro Soler. *Oro Plata: Embroidered Costumes of the Bullfight*. Paris: Assouline, 1997. A visually stunning insight into the production of suits of lights today, via the workshops of Fermín, a Spanish specialist. Superlative black-and-white and color illustrations show a variety of suits on and off their owners, as well as some interesting shots of bullfighters off duty.
- Carretero Pérez, Andrés. *José Ortiz Echagüe en las colecciones del Museo Nacional de Antropología*. Madrid: Museo de Antropología, 2002. Catalog of exhibition held on the work of the photographer José Ortiz Echagüe who actively recorded traditional costume and custom across Spain from the 1920s to the 1960s. The introductory text is a useful evaluation of the visual recording and attitudes to isolated communities.
- Clapés, Mercedes, and Rosa María Martín i Ros. *España: 50 años de moda*. Barcelona: Ajuntament de Barcelona & Centro de Promoción de Diseño y Moda, 1987. This catalog accompanied an exhibition of fifty years of Spanish fashion held at the Palau de la Virreina in Barcelona in 1987. Beginning with Balenciaga and haute couture, it offers succinct biographies of major Spanish dressmakers and fashion designers, illustrated by a photograph of each designer and several of their creations via the fashion press. A few examples of surviving dress in museum collections are included. There are also brief sections on fashion photographers, fashion as art, and a catalog of the exhibited garments.
- Datatèxtil*. Semi-annual magazine published by the Centre de Documentació i Museu Tèxtil de Terrassa. This popular magazine often contains useful articles on Spanish dress and

- textiles, deriving from exhibitions, collections, and from academic theses. Early issues were in Castilian and Catalan, but since 2001, Castilian and English are the two languages in use. In addition, the Centre consistently publishes excellent catalogs that accompany its exhibitions that often delve into local or national aspects of a particular theme.
- Dent Coad, Emma. *Spanish Design and Architecture*. London: Studio Vista, 1990. Beginning with a rapid overview of Spanish fashion since 1492, this chapter introduces regional dress, but concentrates on the fashion industry of the 1980s as represented by official government sources.
- Díaz-Plaja, Fernando. *La vida cotidiana en La España de la Ilustración*. Madrid: EDAF, 1997. An overview of fashion and its use in eighteenth century Spain, drawing attention to the difference between the distinctiveness of Spanish dress of the seventeenth century and the fashionable Spanish assimilation of French styles in the eighteenth century under the ruling Bourbon dynasty.
- Franco Rubio, Gloria A. *La vida cotidiana en tiempos de Carlos III*. Madrid: Ediciones Libertarias, 2001. An overview of clothing and its uses in eighteenth-century Spain which draws attention to the tension between the adoption of an overtly French form of fashionable dress and the retention or reinvention of a native Spanish style.
- García Mercadal, José. *Viajes por España*. Madrid: Alianza Editorial, 1972.
- Herrero Carretero, Concha. *Museo de Telas Medievales. Monasterio de Santa María de Huelgas*. Madrid: Patrimonio Nacional, 1988. Catalog of the museum of medieval textiles in Burgos in which a detailed description of each of the garments found in the thirteenth- and early fourteenth-century tombs of the kings of Castile and León are described, as well as the jewelry and textiles found therein. Fine color illustrations show the textiles before and after conservation.
- Morral i Romeu, Eulalia, and Anton Segura i Mas. *La seda en España: Llegendes, poder i realitat*. Barcelona: Lunweg Editores, 1991. Catalog of an exhibition on silk in Spain, this is a useful introduction to the silk route, sericulture, and silk weaving in Spain, with excellent illustrations of surviving artifacts.
- Morral i Romeu, Eulalia, et al. *Mil anys de disseny en punt*. Tarasa: Centre de Documentació i Museu Tèxtil, 1997. Catalog in Castilian and Catalan from a pioneering exhibition on knitting over the last one thousand years with introductory essays by historians, curators, and designers, this book demonstrates the amount of research that needs to be dedicated to this important area as well as the current state of scholarship. The color illustrations of important knitted objects and graphic material are a useful starting point for any number of projects. They are not limited to Spain.
- Reade, Brian. *The Dominance of Spain, 1550–1660*. London: Harp, 1951. An overview of the fashions of Spain in this period, with a good range of supporting visual evidence mainly drawn from portraits of the period.
- Ribeiro, Aileen. "Fashioning the Feminine: Dress in Goya's Portraits of Women." In *Goya: Images of Women*. Edited by Janis A. Tomlinson. Washington, D.C.: National Gallery of Art, 2002. This article reveals the eighteenth-century Spanish predilection for French fashions and the adoption of Andalusian models, drawing on an unpublished doctoral thesis by S. Worth, "Andalusian Dress and the Image of Spain 1759–1936." Ph.D. diss. Ohio State University, 1990.
- Rocamora, Manuel. *Museo de Indumentaria: Colección Rocamora*. Barcelona: Gráficas Europeas, 1970. A catalog of the major private collection that forms the basis of the national museum of dress in Barcelona with brief descriptions for each inventoried garment, and a few black-and-white and color illustrations that reveal the strengths of the collection.
- Smith, Paul Julian. "Analysis of Contemporary Spanish Fashion, Written from the Perspective of Cultural Studies." In *Contemporary Spanish Culture: TV, Fashion, Art, and Film*. Malden, Mass.: Polity Press, 2003. Covering contemporary Spanish fashion and written from the perspective of cultural studies, chapter 2 offers an analysis of the factors that typify the consumption and production of fashionable dress in Spain, with particular reference to the work and brand of the designer Adolfo Domínguez.

#### Internet Resources

- Cortefiel. Available from <<http://www.cortefiel.com>>.
- El Corte Inglés. Available from <<http://www.elcorteingles.es>>.
- Inditex. Available from <<http://www.inditex.com>>.
- Loewe. Available from <<http://www.loewe.com>>.
- Mango. Available from <<http://www.mango.com>>.
- Pronovias. Available from <<http://www.pronovias.com>>.

Lesley Ellis Miller

#### SPECTACLES. See Eyeglasses.

**SPINNING** The origins of hand spinning, or twisting fiber to make yarn or thread, perhaps date back to the Paleolithic period. An ivory figurine found in France has been carbon-dated to 25,000 B.C.E. The figure is shown wearing a loincloth made of strands which were probably formed by hand-twisting since the earliest known hand spindles are from the later Neolithic period.

#### Hand Spindles

A hand spindle is any implement which can be rotated or twisted by hand to spin yarn or thread. In its most primitive form, a hand spindle can be a branch pulled from a tree or a rock picked up from the ground. In its most common form, it is somewhat like a top. It has a straight shaft with a weight attached to give added momentum. Along with primitive weapons, such as the axe and the knife, it is one of the oldest and most widely used tools of the human race.

The oldest hand-spun weaving fragment found was unearthed at the archaeological excavation of Catal Huyuk in south-central Turkey, and has been carbon-dated to more than 8,000 years old. It appears to be a bast fiber carefully prepared and spun into a very smooth yarn. It was woven at 30 threads per inch in one direction and 38 in the other direction.



Spindle whorls have been found in recent Middle Eastern excavations which date back to 8,000 B.C.E. The date generally accorded to the invention of the wheel is 3,500 B.C.E. Thus, it is possible that understanding the principle of rotation as it was applied in a spindle whorl subsequently led to the invention of the wheel.

### Development of Styles

Hand spindles developed into an astonishing array of styles designed for different types of fibers and yarns and various methods of spinning. Some are designed to revolve freely, suspended from the yarn. Others rotate with the weight of the spindle supported on a surface. Whorls can be positioned at the top, center, or bottom of the spindle shaft. A range of sizes developed, from little needle-like slivers of bamboo weighted with tiny beads of clay to yard-long wooden shafts with large plate-like wooden whorls.

The spindle style most widely used throughout history has been the small bead whorl type. It was the basic spinning tool in India, Africa, Southeast Asia, much of China, and throughout Meso-America.

By 2,500 B.C.E., the Egyptians were spinning linen so fine it could be woven at 540 threads per inch. The Peruvians were able to spin alpaca yarn at 191 miles per pound. The famous Dhaka muslins spun in India measured 253 miles per pound. Using the Tex System of measuring yarns gravimetrically, we can determine that they reached the highest level of skill that it is possible to achieve by hand or machine.

Simple spindles produced all the thread, yarn, and cordage for household use, for commerce, and for war. They met all these needs: clothing, household fabrics, blankets, tents, uniforms for armies, cloth wrapping, and cordage for packages, trappings for animals, rugs and tapestries, sails for ships, and vestments for church and the nobility.

Since spindles are small enough to be carried easily, they were used while walking, shopping in markets, watching flocks, visiting neighbors, and caring for children.

Spindles continued to be used long after spinning wheels appeared. They are still in use in many parts of the world. One can watch them being used in Southeast Asia, the Middle East, North Africa, and Latin America.

### Spinning Wheels

Spinning wheels evolved from the hand spindle. They first appeared in India about 750 C.E. From India they spread to Persia by 1257. They reached China by 1270. The first evidence of spinning wheels being used in Europe occurs in the guild laws of Speyer, Germany, in 1298.

The spinning wheels in Asia did not have legs. The base rested on the floor or ground and the spinners sat on the ground while spinning. In Europe, the base rested on legs. In the simplest design, a spindle with a grooved whorl



**Line art drawing of spindles used throughout the world.** The spindles are used for handspinning, or the process of twisting fiber to make yarn or thread. BETTE HOCHBERG. REPRODUCED BY PERMISSION.

was mounted horizontally between two vertical posts at one end of the base. A large wheel was placed at the other end of the base. A single cord encircled the groove in the whorl and the large wheel. Each time the large wheel revolved one time, the little whorl revolved many times.

The spinner turned the large wheel with one hand, and drafted the fiber as it was spun into yarn with the other hand. The yarn was then wound onto the shaft of the spindle.

### The Great Wheel

As time passed, spinning wheels evolved into what is called the great wheel or walking wheel. The diameter of the wheel grew to three or four feet. Legs were added to the base. The spinner gave a quick turn to the wheel and walked back from the wheel as the yarn twisted, and walked forward to the spindle to wind on the yarn. This style of wheel was usually used for spinning short staple wool and cotton.

Lack of space in small cottages limited its use. Great wheels were about two feet wide and six feet long. They were widely used in northern Europe and were still in use on some American farms in the early twentieth century.

### The Flyer Spinning Wheel

The earliest evidence of a spinning wheel with a flyer is a woodcut illustration in the "Waldburg Hausbuch" in Speyer, Germany, dated 1480. The flyer eliminated the need for the spinner to pause and wind each length of yarn as it was spun.

The flyer holds a bobbin on its shaft. A drive cord is doubled to encircle the large drive wheel and both the whorl on the metal shaft of the flyer and the bobbin, which turns freely on the shaft. Since the groove on the bobbin is deeper than the groove on the flyer, it rotates faster and continuously winds on the yarn as it is spun.

### Adding a Treadle

The Chinese were probably the first people to add foot treadles to spinning wheels. The addition of a treadle meant the spinner could sit comfortably and no longer had to turn the wheel by hand. The design of the spinning wheel as we think of it today was now complete.

### Distaffs

Spinners using either hand spindles or spinning wheels usually used a distaff to hold a ready supply of fibers as they spun. Distaffs could be held in the hand or belt, mounted on a spinning wheel or free standing. They were used throughout Britain, Scandinavia, Russia, Greece, the Middle East, and many parts of Latin America.

They varied from simple sticks to elaborately carved and painted artifacts. Small distaffs designed to be held in the hand or worn on the wrist were used to hold short fibers. Long or tall distaffs were used with long wools, flax, and hemp.

### Preparation of Fibers

Better yarn or thread can be spun from most fibers if they are carded or combed before spinning. To card wool, early people used the dried heads of the teasel plant, which are covered with firm, fine, hooked bristles. This helped to remove debris and align the fibers.

Thorns set into a leatherback were found in a prehistoric lake village in Glastonbury, England. They were used to card animal fibers. Similar carders are still made with wire teeth. Carding removes debris, disentangles the fibers, and more or less aligns them. Combing aligns the fibers and removes the short fibers. Seeds had to be pulled from cotton bolls by hand. Then the cotton was beaten with wandlike sticks to loosen and fluff the fiber before spinning. The most important bast fibers, which are taken from the center stalk of the plant, are linen, jute, and hemp. After drying and retting, they underwent breaking and hackling. This freed the fibers from the stalk.

### Working at Home

Before the industrial revolution, families worked together at home. They raised their own sheep, which provided wool for spinning. Sheep also provided milk, cheese, meat, leather, tallow for candles, and parchment for writing. These could be used by the family and village, or sold to traders. Farmers had economic independence and the freedom it provided.

Families could spin as they watched over the children and farm animals and while walking to town to shop or trade. At night, groups of neighbors gathered together to spin by firelight. They gossiped, told stories, and sang. By working together, families and communities could provide for all of their needs. Skills were passed down from generation to generation. The first sign of change was the "putting out" system. Merchants began to deliver fibers to farms and villages to be spun in homes. This eliminated the cost of maintaining factories, but could not supply sufficient yarn.

### The Industrial Revolution

The population of England doubled in the seventeenth century. There were more people than the farm and village economy could employ. England's leading companies had created enough capital for the industrialization necessary to spin and weave great quantities of fabric cheaply.

The industrial revolution really began with a revolution in the way cloth was spun and woven. All of the conditions necessary to change the family and village-based culture and economy into the factory system occurred in the eighteenth century.

In 1733, John Kay invented the fly shuttle loom, which increased weaving speed and thus the need for more yarn. By 1767, James Hargreaves devised the spinning jenny, which could only spin weft yarn. To supply the need for higher-twist warp yarn, Richard Arkwright

invented the water frame, and by 1782 his mill employed 5,000 workers. The cotton mule, invented by Samuel Crompton in 1779, required only one worker to watch over 1,000 spindles. By the 1780s, Edmund Cartwright devised a way to connect the machines to power supplies.

People from villages, which had bred farmers, craftsmen, and merchants for centuries, now flocked to the cities to find work. Home production could no longer compete in speed and price. Some villages were decimated, with only the old, the infirm, and babies left to fend for themselves. Conditions in most of the early textile mills were deplorable. Children as young as five or six worked long hours. Workers were fined for arriving late, being ill, or breaking any rules. When people could not find work, they turned to drink or begging.

### Hand Spinning and the American Revolution

During this period, economics was guided by mercantilist philosophy. Mother countries expected their colonies to supply them with raw materials at low prices. They would then manufacture great quantities of goods and sell them to the colonies at high prices. British restrictions on American production and trade were major causes of the American war for independence.

American colonists were forbidden to export textiles. It was illegal to transport yarns or yardage from one colony to another. The British decreed the death penalty for anyone attempting to take plans or information or textile machinery to the colonies.

In 1768, Washington commanded his militia to wear hand-spun uniforms, and the Harvard graduating class wore hand-spun suits to protest British restrictions. During the American Revolution, 13,000 hand-spun, hand-woven coats were made for the Continental Army. During the Civil War, most of the Confederate soldiers wore hand-spun uniforms.

The use of cotton in the United States surged forward with Eli Whitney's invention in 1793 of the cotton gin, which made cotton the most widely used fiber in America. By 1816, power looms began to be installed in the United States. At that time, 95 percent of American cloth was still being made with hand-spun yarn.

### Contemporary Hand Spinning

It would be wrong to assume that technological improvements were destined to replace traditional methods all over the world. Hand spinning is still done with all styles of spindles and spinning wheels in many part of Southeast and Central Asia, the Near East, Africa, and Latin America.

In industrially developed countries, hand spinning has become an enjoyable pastime. Excellent spindles, spinning wheels, and looms, and a wide selection of fibers, are available. Many industrialized countries have guilds of spinners and weavers, which meet to share skills and information.

Many art museums have collections of old textiles in which one can see quality that equals or surpasses anything produced by twenty-first century industry. There are excellent art history books in which one can study clothing in paintings of the sixteenth through the eighteenth centuries. Magnificent gilded cut velvets, satins, brocades, and laces are depicted in pictures that were painted on hand-spun, hand-woven canvas.

*See also* **Loom.**

### BIBLIOGRAPHY

- Ciba Reviews*, numbers 14, 20, 27, 28, 48, and 64. Basel, 1939–1948.
- Encyclopedia of Textiles*. Englewood Cliffs, N.J.: Prentice Hall, 1972.
- Hochberg, Bette. *Handspindles*. Santa Cruz, Calif.: B and B Hochberg, 1977.
- . *Spin Span Spun*. Santa Cruz, Calif.: B and B Hochberg, 1998.
- Montell, Gosta. *Spinning Tools and Spinning Methods in Asia*. Stockholm: Tryckeri Aktiebolaget Thule, 1941.
- Singer, Charles, E. J. Holmyard, and A. R. Hall. *History of Technology*. Oxford: Clarendon Press, 1954.
- Weir, Shelagh. *Spinning and Weaving in Palestine*. London: The British Museum, 1970.
- Wild, J. P. *Textile Manufacture in the Northern Roman Provinces*. Cambridge, U.K.: Cambridge University Press, 1970.
- Wilson, Kax. *A History of Textiles*. Boulder, Colo.: Westview Press, 1979.

Bette Hochberg

**SPINNING MACHINERY** The machinery for spinning threads and yarns has evolved from hand spinning flax into linen using a spindle in Egypt as long ago as 4,500 B.C.E. to computer-controlled open-end spinning in 2000 C.E. The evolution of textile processing has been a major contributor to technical development in general. The Romans founded colleges, essentially the first agricultural experiment stations, at which enhancements of the methods for flax and wool production were developed and disseminated throughout their empire. Yarn spinning is needed to impart strength and continuity to collections of fibers, particularly if they are discontinuous. Fibers as short as one inch (2.5 cm) can be formed into continuous yarns by twisting them around each other and, if the fibers have a natural twist, such as cotton, the limit can be as short as 3/8 inch (1 cm).

By around 3,500 B.C.E. the Egyptians started using cotton as a fiber and a parallel development occurred in Peru around 3,000 B.C.E. Since the cotton fibers are round while growing but flatten and become ribbonlike when dry, the shorter fibers can be twisted into a yarn using a supported spindle. However, since cotton was



difficult to spin prior to the development of more mechanized spinning techniques, it was not used extensively in Europe until the industrial revolution.

An important early mechanical innovation for spinning was to attach a whorl, or flywheel, at the lower end of the spindle in order to facilitate rapid rotation, which resulted in an increase in the production rate. In India around 750 C.E. the Charkha, or Jersey Wheel, was developed by mounting the spindle on a frame, and rotated by connection to a wheel, with a treadle being added by the Chinese. Still, the spinning process was discontinuous because the drafting, that is drawing out of the fibers, and twisting were carried out in separate steps. Leonardo da Vinci contributed the flyer, which allows the twisting and winding to be carried out continuously and simultaneously, leading to development in the sixteenth century of an efficient way of spinning that was used for a long time. Subsequently the feeding and drafting of the fibers became the rate-limiting steps in the spinning process, until significant improvements occurred in the eighteenth century: John Wyatt introduced the concept of drafting rollers in 1733, being incorporated by Richard Arkwright into the Water Frame spinning machine. In 1770 James Hargreaves invented a spinning machine named the Spinning Jenny in which the stretching and twisting were mechanized. In 1779 Samuel Crompton combined the concepts of incorporating the drafting rollers, stretching, and twisting into an enhanced spinning machine—which he dubbed the Mule—but it was still a discontinuous process. Charles Danforth's throstle and John Thorpe's frame and traveler are the precursors of the modern continuous ring spinning machines, which revolutionized textile machinery. As a result the spinning speed was limited only by the maximum traveler speed, determined by heat generated due to friction in ring frame.

Until the development of the break spinning, or open-end spinning, drafting and twisting took place concurrently. In open-end spinning, drafting, twisting, and winding are completely separated. The drafting stage ends up with the creation of a stream of individual or single fibers at a point on the spinning line where the air velocity is at its maximum. Subsequently, twisting begins in the "condensation stage," where the velocity is decreased enabling the assembly and twisting of multiple fibers to form yarns, of which fineness depends on the drafting ratio. The most important advantage of open-end spinning is its very high productivity, the package size depending on the winder and not on the spinning device, as is the case with ring spinning.

There are many ways to perform open-end spinning, but rotor spinning seems to be one of the best air-mechanical ways to enhance the technology. As of the early 2000s high performance rotor spinning units can run at speeds up to 150,000 revolutions per minute, delivering yarn at the rate of 235 meters per minute. They

produce large packages of yarn in contrast to ring spinning bobbins that are limited by the size of the spindle.

A critical aspect of yarn spinning from the early spindles to the modern ring spinning and open-end methods is imparting twist to the fibers making up the yarn to provide cohesion and strength. In all cases, that is imparted by taking up the yarn on a rotating device with the collection of fibers being fed either parallel to the long axis of the rotating device or at an angle less than 90 degrees to it. If the fibers were fed perpendicular to the axis of the rotating device, no twist would be imposed. This twisting is accomplished with a spindle by having the fibers fed almost parallel to the long axis of the spindle. For the early spinning wheel this was accomplished by feeding the fibers at an angle onto a mule (a rotating rod), so that they would move toward the opposite end of the take up. In ring spinning the traveler is a guide that spins around the take up guiding the lay down of the fibers (sometimes under computer control) and the traveler is fed nearly parallel to the long axis of the take up. In open-end spinning the fibers are deposited on the inside of a rotating drum after being fed into one end of the drum.

See also **Yarns**.

#### BIBLIOGRAPHY

- Baines, Patricia. *Spinning Wheels: Spinners and Spinning*. New York: Charles Scribner's Sons, 1977.
- Benson, Anna P. *Textile Machines*. Aylesbury, U.K.: Shire Publications, 1983. Shire Album 103.
- Catling, Harold. *The Spinning Mule*. Newton Abbot, U.K.: David and Charles, 1970.
- Dyson, Eric, ed. *Rotor Spinning: Technical and Economic Aspects*. Stockport, U.K.: The Textile Trade Press, 1975.
- English, Walter. *The Textile Industry*. London: Longmans, 1969.
- Lord, P. R., ed. *Spinning in the '70s*. Watford, U.K.: Mellow Publishing Company, Ltd., 1970.
- Wilson, Kax. *A History of Textiles*. Boulder, Colo.: Westview Press, 1979.

*John R. Collier and Simioan Petrovan*

**SPORT SHIRT** The term "sport shirt" describes any of several styles of shirt originally designed and worn for sporting pursuits, but in the early 2000s are incorporated into the broader category of informal or leisure wear. Examples include polo shirts, rugby shirts, and short-sleeved shirts cut similarly to business shirts but in less formal fabrics and colors, and with collars designed to be worn open.

It is almost impossible to discuss a man's wardrobe without mentioning the importance of sportswear in providing some of its key silhouettes throughout recent history. With the decline (and in some places the actual demise) of the suit in the workplace, and by default the

shirt and tie, and the rise of “dress down,” or business casual, men have looked to the clothing they wear in their leisure time as the basis for both adherence to sartorial standards and the display of individual taste. For many, regardless of sporting intention or not, these items tend to have either a sporting association (possibly by celebrity endorsement) or have a dual purpose as sports and casual dress item. Sport shirts play a vital role in the dress-down wardrobe. They are readily available, accessible price-wise, and require little thought when being coordinated with other items.

The polo shirt is a classic example of sportswear filtering through to the mainstream as a fashion staple. Designed for the rigours of the polo pitch during the nineteenth century, the polo shirt was later adapted for the tennis court. The tennis version designed during the 1930s by René Lacoste was welcomed with enthusiasm by the rich and famous on the French Riviera.

With the rise of the leisure-wear market during the 1970s (when many men broke with the tradition of wearing a shirt and tie both during the week as well as on the weekend), the polo shirt was adopted into the working wardrobe and was also worn with jeans or unstructured slacks for leisure time. This marked the advent of an era when men and women began to put comfort first as a criterion for choosing their clothing.

Although Lacoste pioneered the sports-shirt look, Adidas, Fred Perry, Ben Sherman, and (in particular) Ralph Lauren championed the look from the 1980s onward. During this period, its popularity coincided with rise of style tribes such as the mods, casuals, B-boys, and skins. Each group incorporated a particular manufacturer’s version to create its individual look.

During the same period, the generally small and inconspicuous monograms that had been tastefully embroidered on many of these shirts (Lacoste’s crocodile, Lauren’s polo player) were imitated and enlarged by rival companies (Henry Cotton used a fly fisherman, Fiorucci a triangle). Logos and branding came to be an integral part of the look of some polo shirts, rugby shirts, and other leisure wear. The look would be picked up and exploited by many designers and brands, including Tommy Hilfiger, Chipie, Nike, Benetton, and Diesel.

The rugby shirt, like the polo shirt, originated in a jersey garment worn for a particular sport. The standard rugby shirt, with a knit collar and broad stripes (originally in team colors) moved off the playing field and into the leisure wardrobe in the mid-twentieth century and has remained a staple item of male casual dress.

The American men’s outfitter Brooks Brothers was instrumental in developing sports shirts derived from the white shirt that had become standard business wear in the early twentieth century. The company introduced madras cotton shirts (in bright stripes and plaids) in the 1920s, cut similarly to business shirts (though looser-

fitting) but intended to be worn without a necktie. And at least according to legend, John Brooks, president of Brooks Brothers, noticed at a polo match in England that the players had their collars pinned down in order to stop them flapping in the wind. Taking this idea back to America, he developed it into the Brooks trademark button-down collar shirt. Originally intended to be worn, like the polo shirt, as a sports shirt (that is, without a tie and with its top button unbuttoned), the button-down collared shirt was adopted in the 1950s as part of the Ivy League look, worn with a tie, sports jacket, and casual slacks; it is a look that has endured.

*See also* **Polo Shirt; Sports Jacket.**

#### BIBLIOGRAPHY

- Barnes, Richard. *Mods!* London: Plexus Publishing Limited, 1979.
- Byrde, Penelope. *The Male Image: Men’s Fashion in England 1300–1970*. London: B. T. Batsford, Ltd., 1979.
- Chenoune, Farid. *A History of Men’s Fashion*. Paris: Flammarion, 1993.
- De Marley, Diana. *Fashion for Men: An Illustrated History*. London: B. T. Batsford, Ltd., 1985.
- Schoeffler, O. E., and William Gale. *Esquire’s Encyclopedia of 20th Century Fashions*. New York: McGraw-Hill, 1973.

*Tom Greatrex*

**SPORT SHOES** Athletic footwear has become ubiquitous since the mid-1950s, and it is easy to forget that sport shoes were initially designed for a specific purpose—for functionality, comfort, and to maximize athletic performance. As diverse as traditional footwear itself, athletic shoes fall into the following categories: running/training/walking, court sports, field sports, winter sports, outdoor sports, track and field, and specialty shoes (i.e. gymnastics, weight lifting, water, etc.).

Shoe development dates back 10,000 years, stemming from the need for protection from rough terrain. Egyptians used sandals for ball games as far back as 2050 B.C.E. Ancient Roman spiked military shoes called “caliga” were used as weapons against opponents. Greek athletes in the ancient Olympics preferred running barefoot before adopting sandals in the eighth century B.C.E.

Until 1860, more attention was given to style and fashion rather than to functionality—particularly for women. Sport shoes, if worn at all, did not differentiate much from each other and imitated the handmade styles and leather construction of traditional footwear. Skating boots, for example, were merely adaptations of high-cut Victorian style street boots with blades. Leather bars were sometimes placed across the soles of soccer shoes for traction. Football and baseball players wore identical high-cut leather shoes before cleats were introduced in 1890 and fashion determined the height of the boot.



**Early twentieth-century sport shoes.** Sport shoes began to appear in the late 1800s, as increased time for leisure led to the rising popularity of sports in general. © SANDRO VANNINI/CORBIS. REPRODUCED BY PERMISSION.

The popularity of recreational sports, previously restricted to the wealthy upper class, developed in the late nineteenth century as a response to increased amounts of leisure time by the general public. Public interest in sports coincided with the marathon era and the beginning of the modern Olympics. Of significant importance was the advent of the canvas sport shoe—adopting the term “sneaker” in 1873—that followed Charles Goodyear’s 1839 development of vulcanized rubber. From croquet to running, boating, tennis, and bicycling, this multipurpose shoe influenced street fashion with its variations of sateen, canvas, or buckskin uppers and black or brown leather bands.

It was not until the beginning of the twentieth century that mass production of shoes made athletic footwear readily available to the general public. The first great athletic shoemakers, including Joseph W. Foster for Reebok, the Dassler brothers, Marquis Converse, and Leon Leonwood Bean (L.L. Bean) arose at this time. Increased competition in sports accelerated the quest for developing more comfortable, better-performing, flat-soled

shoes. As amateur athletes became professional, they influenced the maturity of sports and athletic shoes became more specialized.

By the 1930s, athletic shoe companies J. E. Sullivan and G. L. Pearce of the Spalding Company, the Dassler brothers (who later split into Adidas, Inc. and Puma, Inc.), Richings of the Riley Company (later renamed New Balance), Chuck Taylor of Converse, and J. Law of England became internationally recognized. Vulcanized rubber sole tennis and basketball shoes, traditionally in black and white shades, were now offered in a variety of colors. Skating boots with Nordic pin binding, previously in black and brown, became available for ladies in white. Interchangeable cleats and nailed-on studs were used for field and winter sports, and track shoes became lighter and more functional.

Out of sheer necessity, protection and function were major factors in the design of many sport shoes. In 1935, inspired by near-fatal accidents involving footwear, Vitale Bramani invented a multipurpose-soled mountain boot and Paul Sperry created a non-slip sole for boating.



L.L. Bean launched his company in 1911 with leather and rubber galoshes that served as a solution to chronically wet feet during his hunting expeditions.

As competition increased on the Olympic track fields and collegiate basketball courts following World War II, better-performing, lighter-weight athletic shoes were highly sought after. Keds and the Converse “sneaker” basketball shoe led the American athletic market while simultaneously becoming an American postwar youth symbol when worn with blue jeans on the streets. Onitsuka Tiger, formed in 1949 and forerunner to the brand Asics, introduced new materials such as nylon uppers and blown rubber wedges and midsoles on their shoes for long-distance runners. New Balance also catered to this group by introducing width fittings and engineering shoes with rippled soles for traction and heel wedges for shock absorption. Bob Lange’s mono-bloc polyurethane injected downhill ski boot invented in 1957 was voted the most innovative shoe construction of the century a decade later.

European manufacturers Adidas and Puma dominated the athletic footwear market in the international sports of soccer, tennis, and track, as they aligned themselves with winning collegiate and professional teams to promote the performance image of their shoes. Adidas’s leather basketball stitched-shell shoe construction, for example, was launched, outfitting half the UCLA and Houston players in their national championship competition. Along with Tiger in Japan, they gave birth to centralized sport-shoe marketing and early biomechanical shoe designing.

By the end of the 1970s, the U.S. sports scene evolved into a more general pursuit of individual fitness. American sport shoe pioneers Bill Bowerman, Jeff Johnson, and Phil Knight (founders of Nike, Inc.) introduced major innovations ranging from nylon uppers and full-length cushioned midsoles to running shoes, the waffle sole, air cushioning, and a variable width lacing system. Meanwhile, traditional U.S. sport shoe companies also began to compete internationally with Europeans and Japanese with “pseudo-athletic” styles to cater to this new market. Reebok, catering to the trend toward fitness activities at the time, created a soft napa leather athletic shoe aimed specifically at the female consumer in 1982.

Spearheaded by the running boom in the United States, sport shoe design went beyond material composition to encompass biomechanical ergonomic footwear design. Biomechanical, electronic, and computer testing were added to the old practice of wear testing. Ratings of running shoes in the magazine *Runner’s World* (established in 1975) also intensified product development improvements. Advanced technological and biomechanical research has made athletic shoes more specialized, more functional, more technical, and more expensive.

Sport shoe companies, once a humble and modest specialized segment seeking practical solutions to footwear problems, developed into trendsetting multibillion-dollar lifestyle brands since the 1950s. Professionalism through



**Golf shoes.** By the end of the twentieth century, specialized sport shoes, such as these golf shoes and spikes, were available for a wide variety of athletic activities, as well as for everyday wear. © ROYALTY-FREE/CORBIS. REPRODUCED BY PERMISSION.

televised sporting events and sports star endorsements has dramatically increased the public’s interest in sports. Advanced science, athletic professionalism, and an increasing population seeking more comfortable lifestyles in the second half of the twentieth century, has provided an environment that allows sport shoes to become even more pervasive in the future of fashion and apparel.

See also **Sneakers; Sportswear.**

#### BIBLIOGRAPHY

- Cavanagh, Peter R. *The Running Shoe Book*. Mountain View, Calif.: Anderson World, 1980.
- Cheskin, Melvyn P. *The Complete Handbook of Athletic Footwear*. New York: Fairchild Publications, 1987. Provides an in-depth analysis of sport shoes, including their history, their technical construction, and contemporary approaches in marketing and advertising.
- Farrelly, Liz, ed. *The Sneaker Book*. London: Booth-Clibborn Editions, 1998. A global collection of opinions covering trendsetting sneakers as social phenomenon.
- Heard, Neal. *Sneakers*. London: Carlton Books Limited, 2003. American collector’s manual of classic athletic footwear in the twentieth century.
- Rexford, Nancy E. *Women’s Shoes in America, 1795–1930*. Kent, Ohio, and London: The Kent State University Press, 2000.

Includes a chapter on women's sport shoes and the relationship between shoe styles and gender roles in American culture.

*Angel Chang*

**SPORTS JACKET** A sports jacket is a short single-breasted coat, originally men's wear but in the early 2000s worn by both men and women. Similar to a suit jacket in fit, detailing, and fabrication, it is usually less shaped than a suit jacket. Originally intended to be worn in the country for sporting pursuits, the sports jacket is often seen in many other contexts as well. Its nineteenth-century ancestor, the original Norfolk jacket, was made of tweed, checked, or herringbone woolen cloth, and was cut quite differently from the sports jacket of the early twenty-first century. The Norfolk jacket was not simply the jacket of a country suit, but a suit jacket designed with a particular purpose in mind; it was intended for, and could only be afforded by, the rich for leisure pursuits.

### History

At its inception, in the 1860s, the sports jacket was part of the hunting attire worn by the Duke of Norfolk. The Norfolk jacket was buttoned high to the neck, had a box pleat centered on its back, and two box pleats in the front. Because of its structure, the jacket was ideal for shooting, with flapped pockets used to store ammunition and provisions; its belted waist allowed for full mobility of the hunter's arm while he was taking aim with his gun. These sports jackets would often be worn with knickerbockers and deerstalker hats or sometimes, less frequently, with bowler hats.

Cut from heavy wool or tweed in autumnal and rural tones such as mustard, ginger, green, and brown (very different from the business stripes and plain colors worn in the city), the sports jacket was rarely worn with another piece of outerwear as it was itself specifically designed for the outdoors.

### The Twentieth Century

By the early twentieth century, the Norfolk jacket, still associated with the rural life enjoyed by the landed gentry and the rich alike, had been modified from its original design. The signature belt and box pleats were removed, and it began to be worn for other country activities, including as garb for spectators at sporting events, and also as an alternative to the traditional suit jacket. The shoulders were fuller, sleeves wider, and the armholes larger. The sports jacket gave men the opportunity to dress differently after work or on the weekends. Just as the lounge suit was beginning to replace formal suiting worn to the office, the tweed jacket became an acceptable part of casual dress.

This new sports jacket, as worn by urban consumers, was cut in a style more akin to that designed for horse

riding and was usually worn with flannel trousers. The New Look sports jackets were typified by angled waisted pockets, a breast pocket, and, often, leather buttons as well as a swelled edge instead of the customary plain buff edge associated with suiting. Further features were developed such as leather patching at the cuff or even on the elbow.

The desire to maintain a clear difference between the attire worn at work and in one's leisure time has clearly driven the sales of the sports jacket. However, many creative professions, such as advertising during the 1960s, began to allow their staff to wear the sports jacket as business clothing. For many, it became an expression of freedom and individualism. The informality of the look gave men the opportunity to be more creative in their choice of fabrics and patterns than they ever could with a formal suit. Even the late Duke of Windsor commented that the brighter a pattern on a sports jacket, the better he liked it.

### Twenty-first Century Sports Jackets

In the early 2000s, sports jackets are available in wide choice of patterns and colors. As the idea of the separate jacket has spread throughout the world, other materials have been employed to allow for climatic variations. Seersucker has become a favorite in the southern United States. Deriving its name from the Persian *sblr-o-shakkar* (literally, milk and sugar), the blue-and-white-striped jacket in this lightweight fabric has become an American classic. The Italians are also noted for making up exceptional lightweight sports jackets in soft fabrics. However, for many, traditional sports jackets cut either on London's Savile Row or bought from a tweed expert such as Cordings of Piccadilly remain classic staples. In these versions, buttons should be made of natural materials, especially horn; the lining should be sewn into the jacket by hand; and should feature working cuffs (that is, with buttons that fasten into buttonholes rather than being sewn on simply as decorations).

As with many other articles of clothing that once were exclusively men's wear, sports jackets have been modified in cut and style for women. The women's sports jacket, worn with trousers or a woolen skirt, forms the foundation of a distinctive style that is simultaneously dressy and relaxed.

For men, the older rule that a sports jacket should be worn with knickers or with a pair of gray flannel trousers has been relaxed. It is fully acceptable to wear a jacket with a smart pair of moleskin, corduroy, cavalry twill trousers, a simple pair of plain woolen trousers, or even jeans. With the increased popularity of casual wear, for many men in the United States and Europe, the combination of a sports jacket and slacks is deemed a somewhat formal look.

*See also Sports Shoes; Sportswear.*

## BIBLIOGRAPHY

- Amies, Hardy. *A, B, C's of Men's Fashion*. London: Cahill and Co. Ltd., 1964.
- Byrde, Penelope. *The Male Image: Men's Fashion in England 1300–1970*. London: B. T. Batsford, Ltd., 1979.
- Chenoune, Farid. *A History of Men's Fashion*. Paris: Flammarion, 1993.
- De Marley, Diana. *Fashion for Men: An Illustrated History*. London: B. T. Batsford, Ltd., 1985.
- Keers, Paul. *A Gentleman's Wardrobe*. London: Weidenfeld and Nicolson, 1987.
- Roetzel, Bernhard. *Gentleman: A Timeless Fashion*. Cologne, Germany: Konemann, 1999.
- Schoeffler, O. E., and William Gale. *Esquire's Encyclopedia of 20th Century Fashions*. New York: McGraw-Hill, 1973.

*Tom Greatrex*

**SPORTSWEAR** At the beginning of the twenty-first century, “sportswear” describes a broad category of fashion-oriented comfortable attire based loosely on clothing developed for participation in sports. “Active sportswear” is the term used to cover the clothing worn specifically for sport and exercise activities. Now generally accepted as the most American of all categories of dress, sportswear has become, from the second half of the twentieth century, the clothing of the world. It consists of separate pieces that may be “mixed and matched,” a merchandising term meaning that articles of clothing are designed to be coordinated in different combinations: trousers or shorts or skirts with shirts (either woven or knit, with or without collars, long-sleeved or short) and sweaters (either pullovers or cardigans) or jackets of a variety of sorts.

### Pre-Twentieth Century

The origins of sportswear, so intimately tied to the rise of sports, are complex, arising from pervasive social change and cultural developments in the mid-nineteenth century. Previously, sport had been the domain of the landed well-to-do, revolving mostly around horses, shooting, and the hunt. Clothing generally was modified fashion wear, but distinctions between the clothing of the country and of town had appeared as early as the eighteenth century. Men, especially young men, wore the new collared, sometimes double-breasted, skirtless but tailed frock for shooting or country wear, itself probably adapted from the military uniform of the early eighteenth century. This coat was quickly adopted into fashionable dress for young gentlemen. Fox or stag hunting called for skirted coats and high boots to protect the legs, and for trim tailoring that would not hamper the rider maneuvering rough terrain and the new fences that were an outcome of the British Enclosure Acts (1760–1840). These acts, by transferring common grazing lands to private holdings, resulted in fences never needed before, thereby adding new challenges to cross-country riding and revolutionizing the sport of hunting.



**Ralph Lauren sportswear.** Two models show outfits from Ralph Lauren's spring/summer 1994 pret-a-porter collection. Elegant sportswear is a hallmark of Lauren's designs. © BROOKE RANDY/CORBIS SYGMA. REPRODUCED BY PERMISSION.

The long, straight, narrow, severely tailored riding coats that emerged toward the end of eighteenth-century England traveled to France as the *redingote*, to become a high-fashion garment for both men and women for the next several decades, through the 1820s. Eventually, red coats became the acceptable color for the hunt, possibly for the obvious reason of making the riders more easily visible. As early as the eighteenth-century, women also adopted severely tailored riding coats based directly on men's styles, creating a standard that still characterizes women's sportswear in the early twenty-first century. Americans, both men and women, followed the English lead in sporting activity. These upper-class choices set the tone and provided the models for the future, but it took democratization to effect change overall. That came with the industrial revolution and the rise of leisure activity among even the poorer classes.

With the movement of the population away from its agrarian past into the cities, reformers realized that the working classes had no real outlets other than drinking





**Active sports ensemble.** A model displays a 1952 Claire McCardell sportswear design. McCardell was one of several American designers who popularized sportswear for women after World War II (1939–1945). The comfort and versatility of sportswear helped it to quickly become a staple of American leisure clothing. © BETTMANN/CORBIS. REPRODUCED BY PERMISSION.

for what little leisure time they had. In an era of revivalist fervor that preached temperance, the concerned middle classes sought other, safer avenues of activity for the poorer classes. Both active and spectator sport and games helped fill that gap. European immigrants to the United States, particularly those from Germany and the Scandinavian countries, brought a variety of outdoor sports and games for men with them, and an accompanying culture of health and exercise that they nurtured in their private clubs. Clothing for these activities was more relaxed than the street clothes of the time, and consisted often of a shirt and trouser combination. Native-born Americans also had had a long history of team games, early versions of various ball games that continued to be played once the population moved to the cities. However, it was baseball, with its singular attire, that most influenced men's clothing for sport. Baseball had emerged as a popular team game with new rules after the first meeting of the elite New York Knickerbocker Base Ball Club with the New York Nines at Elysian Fields in Hoboken, New Jersey, on 19 June 1846. By the 1850s, many other more democratic clubs of workers played the game as well, quickly turning it into America's favorite sport. In 1868,

the Cincinnati Redstockings were the first major team to adopt a uniform of bloused shirt, baggy knee breeches, and sturdy knee socks. The unusual pants, so different from the long stove-pipe trousers of the time, were named after Washington Irving's seventeenth-century character, Dietrich Knickerbocker—not coincidentally the same surname the first baseball team in America had adopted as its own. These became the accepted trouser for active sports in general, and were dubbed "knickerbockers" after the original team. Knickerbockers's success may be seen in their appearance for the next century for shooting, bicycling, hiking, and golf. By the 1920s, they were even worn by women.

Active sports uniforms and clothing grew out of necessity. Players needed protection from bodily harm in contact sports like football and hockey; they also needed to let the body breathe and enable it to move as easily and freely as possible while performing the sport. The entire history of active sports clothing is tied to higher education, the increasingly rapid developments in textile technology, and the Olympics. For example, football, a new and favorite game in men's colleges in the late nineteenth century, adopted a padded leather knickerbocker, pairing it with another innovation, the knitted wool jersey pullover. Lightweight wool jersey, an English invention of the 1880s, was perfect for men's sporting pullovers (which soon were referred to as "jerseys"). Perhaps the most enduring of these has been the rugby shirt—striped, collared, and ubiquitous. It had its beginnings as the uniform for the "new" nineteenth-century game begun at the venerable British school, Rugby, but proved so enduring that it is still worn in the early 2000s, by men, women and children who never thought of playing the game. Jersey was equally adopted into women's dress for sport as well. The new lawn tennis of the 1870s was ripe for a flexible fabric that allowed greater movement, and jersey filled that need by the 1880s. In that same decade, students in the new women's colleges left behind their corsets, petticoats, and bustles for simpler gathered dirndl-style skirts and jersey tops taken directly from men's styles in order to participate in sports like crew and baseball. At the same time, men's schools added a heavier outer layer of wool knit to keep the body warm, and since athletic activity brought on healthy sweating, "sweater" clearly described its role. When a high roll collar was added, the "turtleneck," still a staple of sportswear, was born. The college environment was important because it allowed a looser, less rigid, more casual kind of clothing on campuses frequently isolated from the formality of fashionable urban attire. Soon after the introduction of these pieces of specific clothing for sports in collegiate settings, women borrowed them, wearing them for their own sports and leisurewear from the end of the nineteenth century and on.

The modern Olympic Games introduced new generations of active sportswear. From the first meet in 1896, men appeared in very brief clothing to compete in track

and field and swimming events: singlets, or tank tops, with above-the-knee shorts, and knit—sometimes fine wool and sometimes silk—skin-baring one-piece suits for swim competition. More surprising than these were the bikini-like liners that men wore under the sheer silk suits, without the tops, as typical practice garb. These items became the clothing for sport for men as the century progressed; even the briefs under the suits found their way into swimwear for men and women some half-century or so after their introduction.

### Twentieth Century

Fabrics have played an important role in the development of active sportswear. As with sheer knits at the turn of the twentieth century, so too did stretch fabrics form a second skin shaving seconds off time in competition. From the introduction of Lastex in the 1930s to the spandex of the twenty-first century, clothing for active sports has reflected the attention to sleek bodies, to speed. Speedo, the Australian swimwear company, first introduced its one-piece stretchy suit in the 1950s. From that time on, swimwear became sleeker, tighter but more comfortable because of the manufactured stretch fibers. The concept proved irresistible for men and women in all active sports: new stretch textiles produced ski pants in the 1930s fashioned with stirrups to anchor the sleek lines, bicycle shorts in the 1970s, all-in-one cat suits for skiing, sledding, sailing, speed skating, even running in the 1980s and 1990s. With the biannual Olympic publicity, the new active suits, shorts, and tops found their way into active sportswear and onto athletic bodies everywhere. Even the nonathlete wanted the look, pressing fashion-wear manufacturers to adopt the tight-fitting yet comfortable clothing that technology had made possible.

Sportswear, as opposed to active sportswear, fulfills an entirely different role. Though their roots are the same, sportswear concerns the fashionable aspect of clothing for sport rather than the athletic. Individual items such as jerseys, sweaters, and turtlenecks came directly out of active sports. Certain jackets also became linked with sports and therefore sportswear. The most notable of these, still a staple of modern dress, is the blazer. This standard straight-cut lounge jacket of the late nineteenth century was adapted both by colleges and early sports clubs, the new tennis, golf, or country clubs that emerged in the 1870s and 1880s, who used their own club colors for these jackets, often fashioning them in stripes called “blazes.” Hence, blazers. Striped blazers, popular through the 1920s, have had revivals since, most notably in the late 1950s and 1960s. Generally, however, they gave way to single-colored blazers in the 1930s. The best recognized of these is the bright green Masters jacket of golf.

For women’s leisure wear (and it must be noted that women never wore this casual, “new” clothing in any other setting), women adopted men’s clothing, as they had earlier. This had been noticeable in the 1890s with the clothes of the New Woman, with her blazer, shirt-

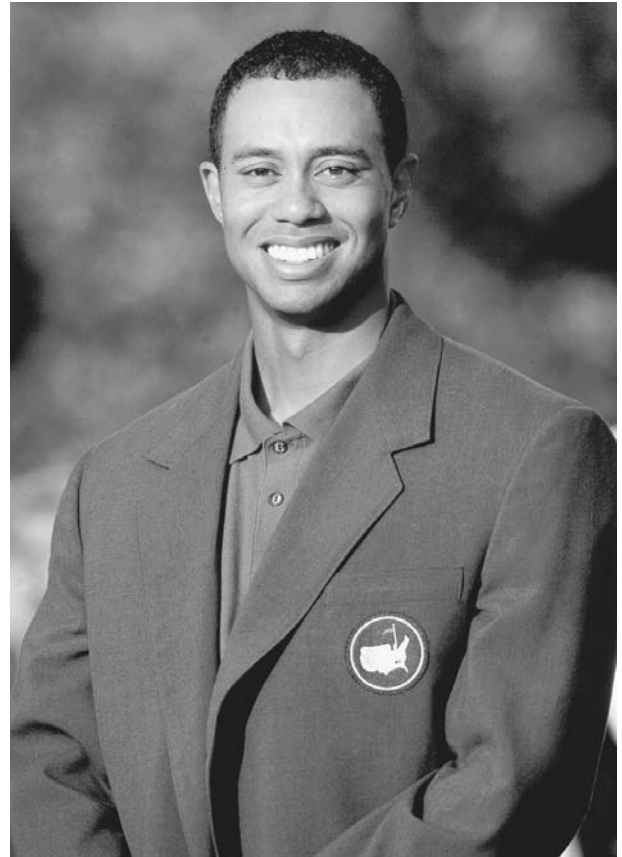

**Tiger Woods.** Golfer Tiger Woods after winning the 2002 U.S. Masters tournament. Woods wears the green blazer that is traditionally given to the tournament’s winner. © SIMON BRUTY/SI/NEWSPO/ORBIS. REPRODUCED BY PERMISSION.

waist, and easy skirt, or even, on occasion (though not as routinely as is now believed) with divided skirts for such activities as bicycling. By the turn of the twentieth century, young women wore jerseys, turtleneck sweaters, and cardigans, borrowed directly from their brothers. In addition, many chose to leave off their corsets when participating in active activities, opting instead for lighter, unboned “sporting waists.” This last move was perhaps the most forward-thinking of all in affecting change in women’s dress. Magazines of the day picked up the new “daring” fashions, with illustrations, to spread them across the country. Early movies, even those prior to the 1920s, also helped distribute and popularize the new styles, showing beautiful young women dressed for all sorts of activities: swimming, golf, tennis and, as time went on, simply for leisure. So the foundations had been laid in the nineteenth century, but the phenomenon of sportswear for women really began in the 1920s with the post-World War I emergence of mass production in women’s wear.

The new loose, unfitted styles of the 1920s allowed a much freer approach to women’s dress for play and



**Rugby players.** A group of rugby players, wearing the striped shirts after which their sport is named. © DUOMO/CORBIS. REPRODUCED BY PERMISSION.

leisure. Although women still clung to skirts, the dresses for such sports as golf and tennis were so admired (to say nothing of the sports figures who wore them, like Suzanne Lenglen, a French tennis champion, and later, Babe Didrickson) that they became day dresses for women whose lifestyles and pocketbooks allowed variety in their clothing. These golf and tennis dresses, with their pleated skirts and tailored tops, sometimes two-piece and sometimes one, comfortable and washable, became the prototypes for the most American of all clothing, the shirtwaist dress. So welcome were tennis dresses that in the 2000s they still prevail over shorts for competition tennis and, as early as the 1940s, offered a new, short skirt length that eventually became accepted into fashion wear.

Trousers for women were another matter. The struggle for their acceptance was a long one, dating from the early nineteenth century when, as baggy “Turkish trowsers,” they were introduced for water cures and exercise, then later adopted as dress reform. It was sport, however, that provided the reason for their acceptance, as long as they were kept within strictly sex-segregated environments like the emerging women’s colleges or all-

women gyms. The heavy serge bifurcated bloomers worn for the new game of basketball were the first acceptable pants for women, and worn with turtlenecked sweaters in the early part of the twentieth century, became an outfit for magazine pinups. The bloomers slimmed down by the 1920s, becoming the popular knickers of that decade, and the introduction of beach pajamas for leisurewear at the same time led to further acceptance, even if not worn in town settings.

The movies helped to sell the image of women in trousers, especially in the 1930s with actresses like Katharine Hepburn and Marlene Dietrich. Even then, women did not wear pants for fashion wear. World War II changed their image, when trousers became the norm for factory workers, but still, pants were not acceptable for the average woman except when she was on vacation or in the country. Indeed, trousers were not accepted for professional working women until the end of the 1970s or early 1980s. But since that time, trousers have become the norm for women everywhere, professionals and vacationers alike, proving once again that women borrow their most comfortable clothing from men’s wear.



Mass manufacturing made the simple items of ready-to-wear sportswear inexpensive and practical for everyone. The notion of designing separates to go together in coordinated fashion, a key concept of sportswear, began in New York in the mid-1920s when Berthe Holley introduced a line of separates that could be interchanged to suggest a larger wardrobe. The concept of easy separates for leisurewear in resort or casual surroundings, if not for more formal wear, grew in the 1930s and finally took hold for more general wear in the 1940s, during World War II. American designers such as Claire McCardell, Clare Potter, and Bonnie Cashin turned to designing ready-made American sportswear, using inexpensive fabrics and following the easy, comfortable styles that made it so popular in the United States. Companies such as B. H. Wragge in the 1940s marketed well-designed separates, particularly to the college-aged crowd, at inexpensive prices that they could afford. After the war, with manufacturing back to prewar norms and the introduction of the more formal New Look from France, the distinction between American and Parisian clothing became even more evident. American designers more and more turned to the casual expressions in fashion that American women loved. By midcentury, the great designers who captured the essence of American style, Bill Blass and Geoffrey Beene, had begun to be recognized, and were turning their attention to ready-to-wear sportswear. Eventually they even brought sportswear ideas into eveningwear, directly translating the shirts, sweaters, and skirts women were so attached to into elegance for evening. Finally, toward the later twentieth century, Ralph Lauren took what had become the staples of sportswear—jackets, sweaters, shirts, pants, and skirts—and gave them a distinctly upper-class edge by reviving the elegance of the club-based sports clothing of the 1930s and 1940s. These later twentieth-century designers captured the American Look and made it their own, turning the higher end of sportswear back to its origins by appealing to the upper classes. But by then, the style of dress known as sportswear was open to all, in all classes and levels of society, through mass manufacturing and mass marketing. A truly American style, sportswear has spread throughout the world, representing a first in clothing history.

See also **Activewear; Blazer; Lauren, Ralph; Sport Shirt; Sweater; Swimwear.**

#### BIBLIOGRAPHY

- Armitage, John. *Man at Play: Nine Centuries of Pleasure Making*. London and New York: Frederick Warne and Co., 1977.
- Mackay-Smith, Alexander, et al. *Man and the Horse*. New York: The Metropolitan Museum of Art and Simon and Schuster, 1984.
- Milbank, Caroline Rennolds. *New York Fashion: The Evolution of American Style*. New York: Harry N. Abrams, 1996.
- Schreier, Barbara A. "Sporting Wear." In *Men and Women: Dressing the Part*. Edited by Claudia Brush Kidwell and Va-

lerie Steele. Washington, D.C.: Smithsonian Institution, 1989, pp. 102–103.

Warner, Patricia Campbell. "The Gym Suit: Freedom at Last." In *Dress in American Culture*. Edited by Patricia A. Cunningham and Susan Voso Lab. Bowling Green, Ohio: Popular Press, Bowling Green State University, 1992, pp. 140–179.

*Patricia Campbell Warner*

**STEELE, LAWRENCE** Lawrence Dion Steele has been known since 1994 for his feminine and unapologetically sexy designs, produced in Milan, Italy. Lawrence Steele was the second of four children, born in 1963 to an Air Force family in Hampton, Virginia. Although Steele was raised in Rantoul, Illinois, he traveled extensively with his family. Working for a jeans company helped finance his education at the School of the Art Institute of Chicago. He graduated from the school with honors and a bachelor of fine arts degree in 1985.

After graduation Steele worked in Japan as an anonymous designer during the 1980s. He always knew, however, that he wanted to establish a business in Milan. Consequently he directed his attention toward Italy's fashion capital, where he lived and worked in the early 2000s.

#### Early Career

Steele began his career in Italy by assisting the design team of Jan and Carlos, known for minimalist design and fine machine-made knitwear. As manager of several collections for designer Franco Moschino from 1985 through 1990, Steele gained valuable experience translating the designer's riotous and radical ideas into actual designs. He was present when Patrizio Bertelli and Miuccia Prada expanded their vision of adding a ready-to-wear line to the Prada luxury leather goods company between 1990 and 1994. Steele recognized the value of their formidable personalities through collaborating with them.

Steele began defining his own fashion philosophy in the early 1990s. In 1994 he launched the Lawrence Steele label with the descriptive title of Platinum s.r.l., produced by Casor SpA in Bologna. The fashion press and industry gave Steele's first collection of 120 garments a particularly favorable response. This initial collection, however, did not reflect the minimalist construction and attention to details that became the hallmarks of his later style. Instead he paraded interpretations of Russian and Eskimo dress down the runway.

Beginning in 1998, Lawrence Steele's knitwear was produced by Miss Deanna SpA in Reggio Emilia. The most outstanding models of the early twenty-first century displayed his 1999 collection, "exalting feminine dress" (Lenoir, p. 27) in New York City. In the same year, Steele introduced LSD as a collection of urban active wear for men and women, made with innovative

technical fabrics and produced by Alberto Aspesi and Company SpA. A Platinum s.r.l. spokesman announced an agreement with the Legnano-based manufacturer to produce and represent the Lawrence Steele label.

### Fashion Innovations

The Lawrence Steele label was available in designer salons in department stores and high-end boutiques around the world in the early 2000s. During his association with Casor, Steele motivated the Bolognese factory to implement new and unusual methods for treating materials. To accommodate their exacting client, Casor's staff perfected gold-leaf finishing on baby alpaca, stretch cashmere, oil-slick neoprene, gold suede, sequin detailing on silk, and multiple zippers on satin. Steele also created ensembles of leather with Lycra at the request of the DuPont Corporation. This exclusive product gives exceptional elasticity to natural leather.

Steele collaborated with the artist Vanessa Beecroft, known for her living compositions and photographic documentation, in a public event in July 2001. Steele identified the event as an aesthetic presentation as opposed to a political protest. Thirty black female models stood motionless for several hours in the Palazzo Ducale of Genoa. The women had been made uniform in color with body paint and identical wigs, and were dressed in black two-piece bathing suits detailed with clear plastic straps. Designer Manolo Blahnik produced the models' spike-heeled footwear according to Steele's suggestions.

### Characteristic Styles

While Steele's demeanor in interviews was calm and sweet, his intensity and ambition radiated through his descriptions of his clothing. "I make the clothes modern women will find utterly desirable; my vision is glamorous, sensuous and a little dangerous and it includes breasts!" (Specter, p. 98).

The on-screen glamor of Diana Ross in the film *Mahogany* dazzled Steele as a boy; as an African American, he proudly acknowledged her as his muse. His ideal female of the early 2000s had a long neck, even longer legs, and a slim, vibrant body. Marlene Dietrich, Marilyn Monroe, and Josephine Baker were the film sirens who appeared on his inspiration boards. Copies of line drawings by Madeleine Vionnet, Cristóbal Balenciaga, Coco Chanel, and Charles James were tacked to the walls of his atelier above random stacks of international periodicals.

Steele's memorable runway presentations attracted the interest of such stylish celebrities as Jennifer Aniston, Naomi Campbell, Erin O'Conner, Lauryn Hill, Meg Ryan, Oprah Winfrey, and Julia Roberts. The atmosphere at his shows compared with the electric excitement of a rock concert. Steele designed a "red carpet" gown in layers of black chiffon with a plunging back and twisted halter detail displaying the shoulder area, which he considered an erogenous zone. He watched Aniston walk down

the aisle wearing the gown he designed for her wedding in 2001—hand-stitched and seed-pearl-encrusted with a 28-yard skirt of silk tulle. "I wanted the effect of a cloud around her feet" (Alexander, p. 29).

### Designs and Artistic Hallmarks

Steele's sophisticated signature was evident throughout his collections of adaptable, supercharged, and sensuous clothing. He combined non-extreme styling, figure-flattering cuts of industrial luxe (such as metal-based fabric), and studied, monochromatic color schemes. He built thematic groups, ranging from "techno" to "viva-glam" (stretch cashmere) (Singer 1998, p. 352), all produced in shiny PVC, fiber-optic nylon, angora, marabou, perforated rubber, glossed chiffon, raffia spikes, netted Swarovski crystals, and slashed leather—examples of his unusual choices of material.

During the development of a Steele collection, swatches of sequined animal prints and paillette-strewn sheer fabrics may be arranged for inspection on the workroom floors of an uncluttered but busy atelier. Press releases described Steele's pieces as modular and precise, insulating and industro-luxe in such colors as metal, bark, and dust. Textures were described in terms of weightless quilting and padded taffeta. Themes derived from popular culture inspired bomber jackets molded in mink and track suits edged in gold braid. Program notes listed such directions as Refined versus Primitive. One collection contained references to "straight forward," "clean," and "necessary."

The designer's philosophy of modern minimalist design was embodied in such themes such as Smoking in Bed, Hand Finished, and New Volume. He mixed tuxedo detailing with lingerie that included oversized crepe pants and camisoles. Steele's floral patterns capitalized on the recognition of computer-generated patterns. Steele persisted in editing and refining his ideas, beginning with the concept of "elegance as refusal" (Singer 1998, p. 358).

*See also* **Blahnik, Manolo; Celebrities; Elastomers; High-Tech Fashion; Moschino, Franco; Prada; Techno-textiles.**

### BIBLIOGRAPHY

- Alexander, Hilary. "Secret Weapon." *Telegraph Magazine* 25 (November 2000): 28–30.
- Lenoir, Lisa. "Steele in the Spotlight." *Chicago Sun Times—Showcase Arts and Leisure* (16 September 1999): 37.
- McDowell, Colin. "Milan's Golden Boy." *The Sunday Times* [London], 5 March 2000.
- Singer, Sally. "Our Man in Milan." *Elle* [USA], September 1998, p. 98.
- . "The New Guard." *Vogue*, (July 2000): 131–140.
- Specter, Michael. "Designer on the Verge." *The New Yorker* (22 March 1999): 96–103.

*Gillian Carrara*

**STOCKINGS, WOMEN'S** The stocking has an established place in the contemporary lexicon of erotic imagery. Elmer Batters, an American photographer, dedicated his life's work to documenting thousands of women in their stockinged feet. Stockinged women offer one of the most powerful images of modern female glamour and provide for the marketing of sexual allure.

### Origins

The stocking was not always considered a sexual symbol. The earliest known example of a knitted sock, flat-cut and seamed at the back, was found in Egypt, where both knitting and weaving are thought to have originated. There is some debate as to whether hand-knitting was introduced to Europe by Christian missionaries, sea traders, or Arabs who, after conquering Egypt in 641 C.E., made their way to Spain. What is known is that it was widely established throughout Europe as a domestic skill by the thirteenth century. The majority of stockings were made from wool, although silk was commonplace for the aristocratic and landed gentry, and were viewed as a covering for the legs that was particularly practical for the climate.

### Mechanical Production

It was the development of the first knitting frame, by Reverend William Lee in Nottingham in 1589, that heralded an era of mechanical production that, along with Marc Isambard Brunel's circular-knitting machine (developed in 1816), was to transform the stocking from practical covering to erotic emblem. Lee's knitting frame took production out of the home, improved and standardized quality, and stimulated a demand for stockings that were an extension of the fashionable consumer's wardrobe.

The introduction of rayon in 1884, a cellulose-fiber material invented in France, changed production in a radical way. Rayon dominated the market for substitute silk stockings, facilitating widespread availability at an affordable price, until the invention of nylon, a more realistic alternative patented by DuPont in 1937. The first nylons were introduced in the United States in May 1940; four million pairs were sold in the first four days.

By the 1960s, the fully-fashioned, "one-size-fits-all" stocking began to outpace the flat-cut, classic seamed stocking, propelled by the introduction in 1958 of stretch Lycra. In addition, Lycra almost completely dispensed with the suspender belt as "roll-ons," early versions of tights, were developed. A British company, Bear Brand, first experimented with tights; by the arrival of the miniskirt in the early 1960s, tights were popular and widely available. Only the introduction of the "hold-up," a stocking with elasticized tops, breathed some life into the stocking market in the mid-1980s.

### Fashion from 1400 to 1900

Men were the principal innovators in stocking fashions during the first few centuries of their introduction to Eu-



**Christian Dior with woman modeling stockings.** Christian Dior kneels at right, working on a new design in 1948. © BETTMAN/CORBIS. REPRODUCED BY PERMISSION.

rope, bright colors accentuating the calves, with cross-garters tied at the knee and ankles embellished with embroidered "clocks" or motifs. In the early Georgian period, women's stockings were woven in complex patterns with intricate embroidery. By 1740, formal dress dictated a plainer white stocking that dominated fashionable evening wear until the 1880s.

In the 1860s, hemlines began to rise and the white stocking was covered in candy-colored riots of spots and stripes; even tartan prints were used to honor Queen Victoria's passion for Scotland. By 1880, they were emblazoned with swallows, butterflies, flowers, and snakes and dyed in rich reds and pale yellows, although the end of the century saw color give way to practical black as women increasingly joined the workplace.



"What are the qualities essential to feminine allure? What is it that attracts and holds the eye of the male? Let me give you a hint. It begins at the tip of the toes and runs to the top of the hose ... legs and feet" (Batters, p. 10).





**Women line up for nylons.** Nylon stockings were first introduced in 1940, and were in short supply during World War II (1939–1945). In 1946, with the war over and shortages easing, these women lined up at Selfridges and Company in London, waiting for a chance to purchase nylons. © HULTON-DEUTSCH COLLECTION/CORBIS. REPRODUCED BY PERMISSION.

### Fashion and Retailing from 1900 to 2003

Women's magazines and mail-order catalogs provided manufacturers with new opportunities to introduce an ever-increasing array of stockings to an interested public. Thousands of small haberdashers were joined by department stores in major cities boasting dedicated hosiery sections. Positive magazine editorial became increasingly important in the aggressive marketing of hosiery products, as women's consumer power continued to grow.

The advent of the cinema heightened the appeal, and facilitated the marketing of stockings. Film stars like Betty Grable propelled the sleek, stockinged leg to iconic status—and it was an attainable glamour. In tandem, packaging design took on all the qualities of gift-wrapped candy—lined paper boxes tied with a bow made stockings a desirable gift. Brands such as Aristoc, launched in the 1920s, Wolford (1946), and Pretty Polly (1950s), are still major players in the hosiery market in the twenty-first century, principally by playing on the glamorous associations of their product—and the idea of womanhood as object of masculine desire, a sensual package waiting to be unwrapped.

The sleek, seamed black stocking was synonymous with postwar fashion, and a focal point for Christian Dior's "New Look" in Paris in 1947. It was another de-

signer, Mary Quant, who revolutionized hosiery fashions a decade later—and signaled the downfall of the stocking as a standard mass-market product. Targeting the new teen, Quant commissioned lacy and patterned tights, emblazoned with her daisy logo, that flattered the miniskirt she made famous in 1963 and expressed the feelings of vibrancy and emancipation that characterized the times. In contrast, by 1971 stockings, now stigmatized as a masculine fetish, held only 5 percent of the market.

As women of all ages turned toward the comfort of tights, lingerie designers who marketed the suspender and stocking did so increasingly as an erotic statement. Of these, the best known is Janet Reger in the United Kingdom and La Perla in Italy. Launching her business at the same time as Quant, Janet Reger appealed to women's desire to look and feel sexy.

### Eroticism

For Elmer Batters (and many others), the eroticism of the stocking and suspender belt lies in the lines they create, framing the female body, and the consideration in dressing that they imply. The stocking's eroticism is, however, a relatively recent development in its history. Women's stockings were not publicly seen until the reign of Charles II, and, as practical coverings, held few erotic connotations until well into the eighteenth century.

It was in performance that the stocking took on an erotic charge; the art of striptease pivoted on the deliberate, prolonged undressing of the female form. Not coincidentally, the “Naughty Nineties” (1890–1900)—the decade of the cancan and the Moulin Rouge—defined the stocking as an erotic symbol. The rustle of petticoats against silk stockings came to signify the repressed sexual energy of the times. For respectable ladies, it was dances like the waltz and the polka, the Charleston and the tango that allowed them to flash gentlemen a glimpse of a silk-clad ankle.

During World War II, American GI’s with a secure supply of nylon stockings frequently deployed them as part of their courtship rituals. The cinema and the pin-up did most to uphold the allure of stockinged feet in the 1950s (Betty Page is one of the most iconic figures of the period), continuing into the 1970s and 1980s. It was another performer, Madonna, who was to alter the stocking’s erotic connotations, liberating it as a symbol of masculine desire as the stocking “acquired the force of a manifesto ... no longer a symbol of slavery,... it announced the liberation of the dominatrix” (Néret, p. 18). It was a trend, begun by Reger in the 1960s, and perpetuated by British lingerie brand Agent Provocateur in the 1990s, toward lingerie, and in particular the stocking and suspender belt, as a positive, feminine choice. In the twenty-first century, the stocking has come to symbolize “a superior kind of woman, bold enough to exploit her assets ... a new concept which has made the notion of the ‘woman as sex object’ obsolete” (Néret, p. 18).

#### BIBLIOGRAPHY

- Batters, Elmer, and Eric Kroll, eds. *From the Tip of the Toes to the Top of the Hose*. Cologne, Germany: Taschen, 1995. An excellent overview of the photographer’s work.
- Corré, Joseph, and Serena Rees. *Agent Provocateur: A Celebration of Femininity*. London: Carlton, 1999. An interesting insight into the philosophy of one of Britain’s most successful lingerie brands.
- Deutch, Yvonne. *A Glimpse of Stocking: A Short History of Stockings*. London: Michael O’Mara Books Ltd., 2002. A brief overview of the subject.
- Hawthorne, Rosemary. *Stockings and Suspenders: A Quick Flash*. London: Souvenir Press, 1993. An excellent, detailed insight into the origins and history of stockings.
- Néret, Gilles. *1000 Dessous: A History of Lingerie*. Cologne, Germany: Taschen, 1998. A comprehensive guide to the retailing and representation of the stocking as an erotic force.

Alice Cicolini

**STONWASHING.** See **Distressing**.

**STREET STYLE** Street style has always existed. It is, however, only since the mid-1950s that its significance has been recognized, valued, and emulated.

Why this change? Arguably the most profound and distinctive development of the twentieth century was this era’s shift from high culture to popular culture—the slow but steady recognition that innovation in matters of art, music, and dress can derive from all social strata rather than, as previously, only from the upper classes. As much as, for example, the twentieth century’s accreditation of jazz, blues, folk, and tango as respected musical forms, the re-evaluation of street style as a key source of innovation in dress and appearance—in the early 2000s, a principle engine of the clothing industry—demonstrates this democratization of aesthetics and culture.

With the development of that system of perpetual style change that is called “fashion” (in the Renaissance), most new designs “trickled down” the socioeconomic ladder to be copied by anyone who could afford to do so. This system was still the order of the day in 1947 when Christian Dior launched his “New Look”: first available only to a tiny, wealthy elite, the tight-waisted and full, voluminous hem of this design rapidly became available in department stores (and via patterns for home sewing) throughout the West. (Interestingly, one of the first prominent British street style “tribes,” the Teddy Boys, might be seen as another example of the “trickle down” principle in that the distinctive styling of their extra-long jackets—and even their name—was copied from the “edwardian” style fashionable amongst some upper-class British men.)

Yet even as the “New Look” demonstrates the extent to which—in the middle of the twentieth century—the high-fashion world remained largely impervious to influences from outside the tight sphere of elite designers and their wealthy customers, a broader perspective on dress reveals a growing appreciation of styles and fabrics with distinct, explicit working or lower-class roots and connotations. Denim is a good example of this: originally worn only by male manual workers, the 1947 and 1948 Sears & Roebuck catalogs both feature casual wear for women and children made from this material. While the designs and catalog presentation of these garments promotes the symbolic context of cowboys and the “Wild West” rather than urban manual labor, it could be argued that the cowboy was the first “working-class hero.” At around the same time, the flamboyant, extrovert, and extravagant zoot-suited “hipster” styles of black jazz musicians and (at the other extreme stylistically) the rough and ready look of the Bikers (models for Brando in *The Wild One*) were increasingly influencing the dress style of the sort of middle-class male who previously had looked only to upper-class style (and upper-class sports) for sartorial inspiration. Thus, even before the end of the first half of the twentieth century, one finds significant examples of “bubble up” replacing the previously all-pervasive “trickle down” process; of the upper class loosening its stranglehold on “good taste” in matters of dress and, therefore, the emergence of street style as a potent and energizing force.



A “**Teddy Boy.**” The distinctive look of London’s Teddy Boys in the 1950s is among the earliest prominent street styles. HULTON ARCHIVE/GETTY IMAGES. REPRODUCED BY PERMISSION.

### A Positive View of Street Style

The dramatic increase in the standardization of life after World War II (suburbanization, mass marketing, the franchising of restaurant and retail chains, the spread of television, and so on) may have increased the appeal of “alternative” lifestyles for individuals in search of “authenticity.” The clothing styles of both the “outlaw” and those “from the wrong side of the tracks” became attractive as symbolic totems of escape from the bland (un)reality of what many cultural theorists have termed “late capitalism.”

Important also was the astounding demographic blip of the “baby boomers” born just after World War II. As this generation grew up in the late 1950s and early 1960s, they came to represent a new sociocultural category—the “teenager”—who, by sheer dint of numbers and the fact that, by and large, they had money to spend, became a significant focus of the economic and cultural worlds. Slow off the mark in its embrace of “youth culture” (and still determinedly upper class and elitist), high fashion had little to offer the average baby-boom teenager who saw street style as a hipper, more authentic, and relevant source of stylistic inspiration. Every street “look” (beat, mod, rockabilly, biker, etc.) brought with it an entire lifestyle package of values and beliefs, a philosophy and, it was often hoped, a new, alternative, community.

This admiration of street style was especially true of young males. Fashionable male dress reached a crescendo

of blandness in the 1950s with the typical, middle-class Western male reduced to near sartorial invisibility. It comes as no surprise, therefore, that street style in the twentieth century was as biased toward men (hipsters, beats, teddy boys, bikers, mods, hippies, psychedelics, skinheads, glam rockers, punks, new romantics, goths, casuals, b-boys, etc.) as fashion has been biased toward women. The rise of street style represents the return of the peacock male from near extinction and this undoubtedly plays a key part in its rising popularity and importance.

Finally, mention should be made of the importance of street style as a facilitator of group identity and sub-cultural cohesion. Since the close of World War II, Western culture has seen a dramatic decline in the significance of the traditional sociocultural divisions such as class, race, religion, ethnicity, regionalism, nationalism, and so on in defining and limiting personal identity. While liberating and egalitarian, this diminishing of the importance of such traditional sociocultural groupings created a huge amorphous, undifferentiated, homogeneous mass within which a sense of community—“People Like Us”—became more problematic. The “tribelike” groupings of, for example, bikers, beats, and teddy boys in the 1950s; mods, hippies, and skinheads in the 1960s; headbangers, punks, and b-boys in the 1970s; and goths, new age travelers and ravers in the 1980s, offered a much needed sense of community—especially for teenagers who, beginning to separate from the parental family but not yet having created their own family unit, feel this need most acutely. Significantly, while throughout human history sociocultural groups have always used dress and body decoration styles to signal and reinforce their group identities and their shared culture, now, for the first time, one’s appearance and style became a sociocultural glue which, it was hoped, would bind together disparate strangers—most of whom would never meet but all of whom shared a culture encrypted in a particular style of dress and music.

From the 1940s through the 1980s street style coalesced into dozens if not hundreds of alternative “tribes”—each with its own complex, integrated sub-cultural system of style, values, and beliefs. Many of these evolved, distinguishing one from the other (hipsters to beats to hippies) while others developed in an antagonistic process energized by opposition (mods/rockers, hippies/punks). In the process, a complex family tree of “styletribes” has spanned (and in many ways defined) several generations.

### An Advertisement of Self

Street style “tribes” offered (and, for many, seem to have provided) that sense of community and shared identity that is so difficult to find in contemporary society. But while significant remnants of many of these subcultures remain scattered around the globe, such commitment and group identity have become less typical of the twenty-first cen-





**Skateboarders.** A group of teenage skateboarders pose for a picture in Manhattan. Many teenagers reject conventional fashions, instead developing their own street styles to better reflect their identities. © ROSE HARTMAN/CORBIS. REPRODUCED BY PERMISSION.

ture. Such looks are now, typically, plucked off the shelf of the post-modern “supermarket of style,” tried out, promiscuously mixed with other looks, and then discarded.

However, while street style may now have entered a post-tribal phase, this is not to suggest that its importance has diminished, since fashion, in its strict, traditional sense, no longer structures and empowers most of the clothing industry. As the supreme expression of modernism, fashion’s orderly, lineal production of new, “New Looks” and the consensus in the form of a singular, progressive “direction” that it demanded, is ill-suited to the complexity and pluralism of the postmodern age within which the possibility of progress, the value of uniformity, and the desirability of transience are increasingly questioned.

Originally attractive because of its perceived “authenticity,” its offer of “alternative” choice and its capacity to “say” something significant about those who wear it, street style has moved into a key position within the clothing industry in a postmodern age characterized by a crises of identity, truth, and meaning. This is to say, not only has the “fashion industry” come to increasingly

and persistently look to “the street” for design inspiration, but, more significantly, that how clothing functions in the early 2000s from the perspective of the consumer—how it is purchased, worn, and valued—is more rooted in the history of street style than in the history of high fashion. Consumers have, in other words, moved a very long way indeed from the world of Dior’s “New Look” in 1947 and the direction of this movement is commensurate with that approach to dress and appearance that has come to be known as “street style.”

The “bubbling up” of stylistic inspiration (often, modeled by up-and-coming pop musicians) has become widespread within every segment of the clothing industry including “High Fashion.” Moreover, street style’s delight in “timeless classics” and its disdain for the ephemeral (Hell’s Angels never coveted “This Season’s New Biker Look”) is seen in a widespread resistance to throwing out everything in one’s wardrobe just because some fashion journalist might claim that “brown is the new black.” While once the consumer sought out a “total look” from a particular designer, it is increasingly



**Motorcycle gang from *The Wild One*.** Johnny Strabler (Marlon Brando, center) and his motorcycle gang from the 1953 film *The Wild One*, which helped to popularize the tough, leather-clad look of bikers, is an early example of a street style influencing fashion. © JOHN SPRINGER COLLECTION/CORBIS. REPRODUCED BY PERMISSION.

thought that only a pathetic “fashion victim” takes such a passive approach. Thus, the construction of a presentation of self is increasingly seen as the work of the creative individual.

To this end, in a process that can be traced directly back to the Punks, the twenty-first century consumer—using garments and accessories from different designers, brands, or charity shops as “adjectives”—samples and mixes an eclectic (often even contradictory) range of looks into a personal style statement. This emphasis on what a look has to “say” also largely derives from street style. While pure fashion articulated only “This is new and I am therefore fashionable,” street style was always deeply resonate with more complex personal (even philosophical and political) meanings—a choice of cut or color or fabric calculated to convey a precise summary of attitude and lifestyle. Street style obliged the individual to wear his or her values and beliefs on the sleeve—in a way that

more often than not required commitment and courage. Arguably, it is this capacity to give visual expression to where one is “at”—to articulate personal differences and, therefore, to create the possibility of interpersonal connection between like-minded individuals—which, in an age of too much communication and too little meaning, is street style’s most valuable legacy.

See also **Hippie Style; Punk; Subcultures; Teenage Fashions; Zoot Suit.**

#### BIBLIOGRAPHY

- Chenoune, Farid. *A History of Men’s Fashion*. Paris: Flammarion, 1993.
- Hebdige, Dick. *Subculture: The Meaning of Style*. London: Methuen and Co., 1979. A key text in the development of subcultural theory.
- MacInnes, Colin. *Absolute Beginners*. London: Allison and Busby, 1992. A novel that was originally published in 1959.



- McRobbie, Angela, ed. *Zoot Suits and Second-hand Dresses: An Anthology of Fashion and Music*. London: Macmillan, 1989.
- Melly, George. *Revolt into Style: The Pop Arts in the 50s and 60s*. Oxford: Oxford University Press, 1989. A classic text; originally published in 1970.
- Muggleton, David. *Inside Subculture: The Post-Modern Meaning of Style*. Oxford: Berg, 2000.
- Muggleton, David, and Rupert Weinzierl, eds. *The Post-Subcultures Reader*. New York: New York University Press, 2003.
- Olian, JoAnne. *Everyday Fashions of the Forties: As Pictured in Sears Catalogs*. New York: Dover Publications, Inc., 1992.
- Polhemus, Ted. *Streetstyle: From Sidewalk to Catwalk*. London: Thames and Hudson, Inc., 1994. A summary of all significant "styletribes" from 1940s to 1990s; includes book, music, and film references for all groups in "Further Information."
- . *Style Surfing: What to Wear in the 3rd Millennium*. London: Thames and Hudson, Inc., 1996.
- Redhead, Steve. *Subculture to Clubcultures: An Introduction to Popular Cultural Studies*. Oxford: Blackwell Publishers, 1997.
- , ed. *The Clubcultures Reader: Readings in Popular Cultural Studies*. Oxford: Blackwell Publishers, 1998.

*Ted Polhemus*

**STRIPED CLOTH** The term "striped cloth" describes any textile woven, knitted, or printed in such a way that bands of different colors, evenly or unevenly spaced, appear on the surface of the fabric. Striped cloth is usually warp-faced cloth (that is, cloth in which the warp yarns lie on the cloth's surface) in which the warp yarns are laid out in bands of different colors, but striped cloth can also be weft-faced, or knitted, or printed to emulate woven stripes. Fabrics in which bands of different colors appear in both the warp and the weft (or are printed in such a pattern) are known variously as checks, gingham, tartan, and plaid.

### Origins

Striped cloth is found among some of the earliest extant examples of woven textiles and must have arisen as a natural consequence of the color variability of yarns, particularly woolen yarns. Randomly distributed warp yarns of different colors or shades would have spontaneously produced a sort of asymmetrical striped cloth; it would then have been a very small step for the weaver to stretch her warp in such a way as to space out at even intervals the varying colors of yarn, producing true striped cloth. The use of yarns dyed in different colors must have been the next, equally obvious, step in the process of producing striped cloth. By early historic times, striped cloth was a normal part of the weaver's repertoire in cultures around the world, although it does not appear that the wearing of striped cloth predominated in any of the societies of antiquity.

### The Devil's Cloth

As the French social historian Michel Pastoureau has pointed out, in the European Middle Ages striped cloth took on strong connotations of deviance and abasement. Servants and court jesters wore striped cloth; so did prostitutes, madmen, and criminals, not voluntarily but by official orders. The bold, broad, contrasting stripes of their garments seemed to stand for neither-this-nor-that, ambivalence, ambiguity, and a realm of unclear and violated boundaries. This connotation of striped cloth is with us still; a jumpsuit or a tunic-and-trousers combination garment made of broadly striped cloth, in either horizontal or vertical stripes, instantly carries the association of prisoners, convicted criminals, or, in a tragic variation, inmates of concentration camps. A loose, lightweight pajama-like union suit of brightly striped cloth, with a broad collar and cuffs, is the iconic outfit of the clown, a figure whose humor derives from his license to transgress the boundaries of orderly society.

The wearing of stripes was not always a sign of social deviance, but even as a fashion statement, stripes had connotations of boldness and daring, a willingness to test the boundaries of social tolerance. The broadly striped hose worn by young men in the Italian Renaissance, familiar from countless paintings and tapestries, gave them a swaggering air that must have seemed impudent and shocking to their more soberly dressed elders.

Striped cloth also had a role to play in heraldry, as overjackets, streamers, and banners of colored stripes could be used to display the colors of knights in combat or in the simulated combat of the tournament. The heraldic use of striped cloth survives in the practice of suspending medals signifying civil and military honors from striped grosgrain ribbon, with the color, width, and placement of stripes specified exactly by the rules of the decoration. In some cases the honor also includes the right to wear a wide sash of striped ribbon in the same colors as the ribbon of the medal itself. Ribbon in the tricolor pattern of red, white, and blue, often folded into a rosette worn as a hat decoration, became a potent symbol of the French Revolution.

### Stripes in Fashion

Although striped cloth never entirely lost its connotations of danger and deviance, it acquired other associations, so that by the eighteenth century striped cloth entered the repertoire of ordinary European fashionable clothing. In particular, striped clothing acquired sporting or leisure connotations; Victorian paintings of seaside scenes frequently show women strolling in long summer dresses of black-and-white or blue-and-white striped fabric. As this association with the seaside suggests, stripes also called to mind nautical images. Woolen sweaters knitted with horizontal stripes of blue and white became standard gear for sailors, from Venetian gondoliers to crew members of private yachts.



The almost infinite number of possible combinations of colors and widths in which striped cloth could be produced led to a continued symbolic use of striped garments in a way that distantly recalled the old rules of heraldry. Boating clubs and cricket teams at English universities frequently sported boldly striped blazers in club colors. Neckties in stripes of prescribed colors and widths (with the cloth cut on the bias to produce diagonal stripes) similarly were used to identify members of military regiments, alumni of university colleges, clubs, and similar affinity groups.

The associations of striped cloth with leisure and sporting pursuits also made sturdy striped canvas popular for the upholstery of outdoor furniture, the canopies of beach umbrellas and cabanas, and the like. In the early twentieth century, before the invention of air-conditioning, buildings in Western cities were festooned in summertime with brightly striped awnings to keep sunshine and rain from entering open windows.

### Striped Cloth in the Twenty-First Century

Since World War II, striped cloth has occasionally been fashionable for women's attire, and almost any year's ready-to-wear collections will include some striped dresses, skirts, and shirts. Horizontally striped sweaters remain sportswear standards for both men and women. But the major uses of striped cloth today are so understated as to escape immediate notice; striped cloth is primarily used now for men's suiting materials and for men's dress (business) shirts and ties. Partly in the hope that vertical stripes produce an illusion of a slimmer and taller body, many men wear dark suits with very thin stripes (pinstripes) or slightly fuzzy stripes (chalk stripes) of white or some other light color. Shirting materials, too, are frequently woven in white or light colors with dark pinstripes, or in stripes of even width (often of blue and white). In some years bright, multicolored stripes come into fashion; these are often made up into shirts with white collars and cuffs. And plain shirts are often worn with "regimental" striped ties (which, in America at least, seldom have or retain their specific symbolic associations). Sober business attire is the last bastion of a type of cloth that once had a far wider and more exciting range of meanings.

*See also* **Nautical Style; Neckties and Neckwear; Prison Dress; Ties; Uniforms, Sports.**

### BIBLIOGRAPHY

- Köhler, Karl. *A History of Costume*. Reprint, New York: Dover Publications, 1963.
- Molloy, John. *Dress for Success*. New York: Peter H. Wyden, 1975.
- Pastoureau, Michel. *The Devil's Cloth: A History of Stripes and Striped Fabric*. Translated by Jody Gladding. New York: Columbia University Press, 2001.

*John S. Major*

**STRIPTEASE** Publicists coined the word striptease in the late 1920s. It is still an evocative word, bringing to mind the lurid image of a busty, 1950s performer bumping and grinding in tasseled pasties and a sequined g-string. This icon of overtly commercial sexuality had its heyday in the 1950s, but the history of the striptease reaches as far back as the nineteenth century.

Starting in the 1850s, what is often referred to as the "scandal of tights" swept through America. Flesh-colored stockings were worn on the stage by comedienues, chorines, and cancan dancers revealing limbs that had been all but eliminated from the fashionable silhouette. The costume shocked audiences, but was allowed by censors since it had originated on ostensibly respectable stages in Europe, such as the Gaiety in London and the Folies Bergère in Paris. These nineteenth-century performers never actually disrobed, but they were harassed, fined, and occasionally jailed for pulling up their skirts, flashing their underwear, and swiveling their hips in a way that evoked the throes of passion. In 1893, the American purveyors of the tights-clad leg show, found mainly in burlesque and vaudeville theaters, shed even more clothes in order to adapt the "exotic" dance of the Chicago World's Fair's Little Egypt (whose performance launched the first and longest-lived euphemism for the stripteaser: exotic dancer).

The element of bare flesh was introduced around the turn of the century at the tea parties of socialite ladies. Early modern dancers like Isadora Duncan, Ruth St. Denis, and Maud Allan scandalized moralists with the degree of physical exposure in the costumes for their dances that were launched through the patronage of wealthy women interested in Orientalist art and culture. Duncan performed at ladies' matinees in bare feet and without tights, dressed only in a classical gown (made at first of her mother's muslin curtains). St. Denis adopted the exotic dance of the World's Fairs and dressed in ultra-sheer and bejeweled net garments. Allan developed a Dance of the Seven Veils based on the biblical story of Salome that was so popular that prominent women were inspired to hold a costume party of Salome-style dress. Through the popularity of modern dancers, a formula was filtered into American popular theater where numerous young women reduced their stage costumes to gauzy skirts, beaded bras, and bared midriffs in an effort to interpret foreign cultures, real and imagined, through the art of dance.

By the 1910s, the first accounts of striptease appeared on the heels of the advent of modern dance. Vaudeville historian Joe Laurie, Jr. claimed that vaudeville headliner Eva Tanguay let the veils drop in her version of the Salome dance in 1912. Morton Minsky claimed that burlesque performer Mae Dix invented it when she removed the detachable collar and cuffs of her costume in full view of the audience in order to save on her cleaning bill. Former stripteaser Ann Corio credited Hinda Wassau with inventing the act when forced to shimmy out of a cho-

rus costume that had caught on the beads of the ensemble worn beneath for purposes of a quick change. The “Glorified Girls” featured in the mainstream Broadway revue of Florenz Ziegfeld, Jr. also made nudity more and more acceptable on the stage with opulent *tableaux* such as “Lady Godiva’s Ride” in the *Follies of 1919*.

The acceptance of nudity necessitated bawdy entertainment to up the ante further in order to secure their lucratively raunchy reputations. The result was striptease. The precedent of nudity established by modern dancers implied artistic motives. The striptease represented a return to the flash-and-tickle approach of populist vaudeville dancers. That was infinitely more appealing to male audiences and it was achieved not through nudity, but through an undressing that mimicked the disrobing which preceded a sexual encounter. The formula was simple: the slow parade of a beautiful girl in a beautiful gown; the removal of stockings, gloves, hairpins; the slow shimmy out of the clinging, formal dress; and the briefest wriggle in only a g-string. Nudity made artistic became artistry made erotic.

Four burlesque producer brothers named Minsky became inextricably connected with striptease in the 1920s. Their publicists, George Alabama Florida and Mike Goldreyer, came up with the name for it and promoted its finest practitioners. These included Margie Hart, Georgia Southern, Ann Corio, and the incomparable Gypsy Rose Lee. When the Great Depression came, the Minskys were able to lease a theater on Broadway. Gypsy Rose Lee thrived in Minsky shows during this era and set the tone for high-style striptease as an extremely beautiful woman who was also an engaging comedienne and natural-born celebrity. The Minskys were so successful that theater producers and real-estate interests (along with some conservative religious organizations) banded together to get the act of striptease itself banned in New York City. They succeeded in 1937 when the word burlesque and the name Minsky were banned in New York City, and all the theaters that featured striptease were shut down. Similar bans followed in other cities across the nation.

Throughout the 1940s, a few burlesque houses survived and Minsky strippers used their fame to headline shows on carnival midways. In the years following the crackdown on striptease, some concessions were made to avoid trouble with the law. The use of pasties to cover the aureolas was the most noticeable change, but the addition of sequins, rhinestones, and tassels changed pasties from a handicap to an innovation. As nightclubs entered a boom following World War II, striptease came back in style again. A 1954 *Newsweek* article reported that the number of strippers had quadrupled since the 1930s and that 50 nightclubs in New York City featured striptease. The article gleefully recounts the props in the shows (snakes, monkeys, macaws, doves, parakeets, stuffed horses, swimming tanks, and bubble baths); the cost of the costumes



**Dance of the Seven Veils.** Lyn Seymour rehearses for a production of Oscar Wilde’s 1891 play, *Salome*. Although tame by modern standards, the “Dance of the Seven Veils” performed in the play helped begin a trend towards the seductive, near-nude dancing known as striptease. © HULTON-DEUTSCH COLLECTION/CORBIS. REPRODUCED BY PERMISSION.

(\$850 to \$1,000 for Lili St. Cyr’s Vegas act); and the stage names in use (Carita La Dove—the Cuban Bombshell, Evelyn West—the \$50,000 Treasure Chest Girl). The star performers of this era employed all the over-the-top shtick of 50 years of vaudeville in their acts. Blaze Starr had a red settee, which she had tricked out with a fan, canned smoke, and a piece of bright silk that would appear to go up in flames. Lili St. Cyr did interpretive striptease based on *Salome*, *Carmen*, *The Picture of Dorian Gray*, and *Sadie Thompson*. Tempest Storm promoted herself relentlessly, dating celebrities and accepting a mock award from Dean Martin and Jerry Lewis for having the two biggest props in Hollywood. These acts were so popular that in 1951 Frenchman Alain Bernadin opened the Crazy Horse Saloon in Paris to bring American-style striptease to European cabaret audiences. Another garish heyday for striptease had arrived. But by the 1960s, that heyday had come and gone.

In the decades that followed, striptease was rejected in favor of the direct appeal of already bare flesh. The

topless trend kicked off in the mid-1960s when a go-go dancer at a San Francisco strip club performed in Rudi Gernreich's topless bathing suit without getting arrested. Topless lunches, topless shoeshines, and other mundane acts improved by toplessness were featured in the clubs that had showcased striptease. Bottomlessness logically followed. By the 1970s, the hugely profitable pornography industry almost eclipsed live nude girls altogether. Crackdowns on the pornography industry in the 1980s encouraged a resurgence of striptease, but much of the glamour and humorous shtick of 1950s striptease was excised in favor of the intimacy of the lap dance for an audience of one and as a result, the theatrically-inclined tassel-twirling stripteaser was replaced by the more readily accessible silicone-enhanced bottle blond with one leg wrapped around a metal pole.

## BIBLIOGRAPHY

- Alexander, H. M. *Strip Tease: The Vanished Art of Burlesque*. New York: Knight Publishers, 1938.
- Allen, Robert C. *Horrible Prettiness: Burlesque and American Culture*. Chapel Hill: University of North Carolina Press, 1991.
- Cherniasky, Felix. *The Salome Dancer: The Life and Times of Maud Allan*. Toronto, Ontario: McClelland and Stewart, Inc., 1991.
- Corio, Ann with Joseph DiMona. *This Was Burlesque*. New York: Madison Square Press/Grosset and Dunlap, 1968.
- Derval, Paul. *Folies-Bergere*. New York: E. P. Dutton and Co., Inc., 1955.
- Fields, Armond, and L. Marc Fields. *From the Bowery to Broadway: Lew Fields and the Roots of American Popular Theater*. New York and Oxford, U.K.: Oxford University Press, 1993.
- Jarret, Lucinda. *Stripping in Time: A History of Erotic Dancing*. London: Pandora-Harper, 1977.
- Laurie, Joe, Jr. *Vaudeville: From the Honky-Tonks to the Palace*. New York: Henry Holt and Company, 1953.
- Lee, Gypsy Rose. *Gypsy*. Berkeley, Calif: Frog, Ltd., 1957.
- Macdougall, Allan Ross. *Isadora: A Revolutionary in Art and Love*. New York: Thomas Nelson and Sons, 1960.
- Mariel, Pierre and Jean Trocher. *Paris Cancan*. Translated by Stephanie and Richard Sutton. London: Charles Skilton Ltd., 1961.
- Minsky, Morton. *Minsky's Burlesque*. New York: Arbor, 1986.
- Parker, Derek and Julia Parker. *The Natural History of the Chorus Girl*. Indianapolis, Ind., and New York: Bobbs-Merrill, 1975.
- Shelton, Suzanne. *Divine Dancer: A Biography of Ruth St. Denis*. New York: Doubleday, 1981.
- Sobel, Bernard. *Burleycuc: An Underground History of Burlesque Days*. New York: Farrar and Rinehart, Inc., 1931.
- . *A Pictorial History of Burlesque*. New York: Bonanza Books, 1956.
- Starr, Blaze and Huey Perry. *Blaze Starr: My Life as Told to Huey Perry*. Warner Paperback Library Edition. New York: Praeger Publishers, Inc., 1975.
- Stencell, A. W. *Girl Show: Into the Canvas World of Bump and Grind*. Toronto, Ontario, Canada: ECW Press, 1999.
- Storm, Tempest. *The Lady Is a Vamp*. Atlanta, Ga.: Peachtree Publishers, Ltd., 1987.
- Zeidman, Irving. *The American Burlesque Show*. New York: Hawthorn Books, Inc., 1967.
- Ziegfeld, Richard and Paulette. *The Ziegfeld Touch: The Life and Times of Florenz Ziegfeld, Jr.* New York: Harry N. Abrams, 1993.

Jessica Glasscock

**SUBCULTURES** A point on which many costume historians have concurred is that fashion, as it is currently understood—the propensity for continual change in clothing designs, colors, and tastes—is a relatively recent phenomenon in the history of humankind, virtually unknown before the fourteenth century and occurring only with the emergence of mercantile capitalism, the concomitant growth in global trade, and the rise of the medieval city. (Among the few exceptions are Tang Dynasty China and Heian Period Japan.) Other scholars have analyzed fashion as an aspect of a distinctively modern and Western consumer culture that first gained impetus in the eighteenth century, concurrent with the onset of the industrial revolution. Either way, to be “fashionable” in this sense of the term must not be understood as a natural, universal, or biologically given aspect of human behavior, but as a socially and historically specific condition. Fashion is, in other words, a cultural construction. Its very existence, form, and direction are dependent on the complex interplay of quite specific economic, political, and ideological forces.

If fashion is cultural then fashion subcultures are groups organized around or based upon certain features of costume, appearance, and adornment that render them distinctive enough to be recognized or defined as a subset of the wider culture. Depending on the group in question, subcultures may be loosely or tightly bounded; their collective identification may be self-attributed or imputed to them by outsiders. A particular gender, age span, social class, or ethnic identity may dominate membership. Subcultures often create their own distinctiveness by defining themselves in opposition to the “mainstream”—the accepted, prescribed, or prevailing fashion of the period. They may be either radical and forward-looking or reactionary and conservative in relation to the dominant mode of dressing: in either case, they aim toward exclusivity. Thus, while these subcultures may depend upon fashion for their very existence, their members may dispute the relevance of fashion (as both phenomenon and terminology) to their own identity, perhaps preferring to orient themselves around the idea of “style” or “anti-fashion.” “Anti-fashion is that ‘true chic’ which used to be defined as the elegance that never draws attention to itself, the simplicity that is ‘understated’... Anti-fashion attempts a timeless style, tries to get the essential element of change out of fashion altogether” (Wilson, pp. 183–184).



### Early Examples

Elizabeth Wilson's *Adorned in Dreams* includes a useful introductory discussion of certain forms of early, European fashion subcultures that favored rebellious, or oppositional, dress. Along with the "great masculine renunciation" of the early nineteenth century, in which men forsook foppish perfumed effeminacy for classic understated sobriety, came the figure of the Regency dandy. Although English in origin, dandyism soon found a resonance in post-revolutionary France, where it was adopted by the avant-garde youth subculture, the *In-croyables*. The typical dandy was undoubtedly motivated by a narcissistic obsession with image, display, and the presentation of the self through dress; yet his overriding concern was with sheer quality of fabric, fit, and form, not overbearing or ostentatious ornamentation. This coeerie of young gentlemen was thus characterized by an ethos of stoical heroism, a disciplined quest for refinement, elegance, and excellence, the diverse historical legacy of which can be seen in male Edwardian dress, the 1960s mod subculture, and the character of John Steed in the cult TV show, *The Avengers*.

The fastidiousness of the dandy can be contrasted with the flamboyance of the bohemian, who also emerged in the early nineteenth century, but as a romantic reaction against the perceived de-humanizing utilitarianism and rationalism of the industrial revolution. Although often solidly upper-middle class in origin, the romantic rebel—as artist, visionary, or intellectual—was fundamentally anti-bourgeois in tastes and outlook, their moral quest for self-renewal through art synonymous with a desire to escape the inhibitions of conventional lifestyles and appearances. Bohemian countercultures have been a feature of many major Western urban centers of creativity—Paris, London, New York, Berlin, San Francisco—at regular intervals over the past two hundred years. From the casual neckties, romantic robes, and ethnic exoticism of the early French bohemians, via the existentially-inspired black uniform and pale complexions of the 1950s beatniks, to the natural fibers, Eastern-influenced designs, and psychedelic aesthetic of the 1960s hippies, Wilson's book provides descriptions of their many and varied forms of sartorial dissent.

Because calls to free the physical self from the strictures imposed by social conventions of dress can imply a need for either increased functionality of design or a relaxation of hitherto too rigid forms, oppositional fashions and attempts at reformist dress can display both puritan rational and aesthetic romantic elements. Artistic or aesthetic dress of the nineteenth century called for the natural and free-flowing draping of the female body at a time when the tightly corseted, narrow-waisted, and heavily bustled female was the height of popular fashion; yet it is interesting that a movement founded in 1881 to free women from precisely these restrictions and impediments of conventional Victorian dress should be called "The Rational Dress Society." In the Soviet Union of the 1920s,



**Hell's Angels.** A member of the Hell's Angels Motorcycle Club, in Los Angeles, California, 2000. American motorcycle gangs cultivate a distinctive appearance that sets them apart from mainstream fashion, helps them to identify other members of the biker subculture, and identifies their place within that subculture. © TED SOQUI/CORBIS. REPRODUCED BY PERMISSION.

the rational aspects of dress design were underpinned by the scientific tenets of Marxist-Leninism. Constructivist artists such as Vladimir Tatlin, Liubov' Popova, and Varvara Stepanova combined geometric Modernist motifs with the principle that form follows function to address the utilitarian clothing needs of urban industrial workers. The resulting revolutionary garments, intended for mass production, were destined, however, to remain—like aesthetic dress—a minority taste—the artistic expression of an avant-garde subculture.

### Youth Subcultural Styles

**The British context.** Despite assumptions to the contrary, working-class youth subcultures, based around distinctive, dissenting styles, were not confined to the period after World War II. Geoffrey Pearson, for example, in a study of the "history of respectable fears," notes the presence in late-nineteenth-century Britain of the troublesome teenage "hooligan" (an Australian equivalent of the same period was known as the "larrikin"). Notwithstanding some regional variations in style between the

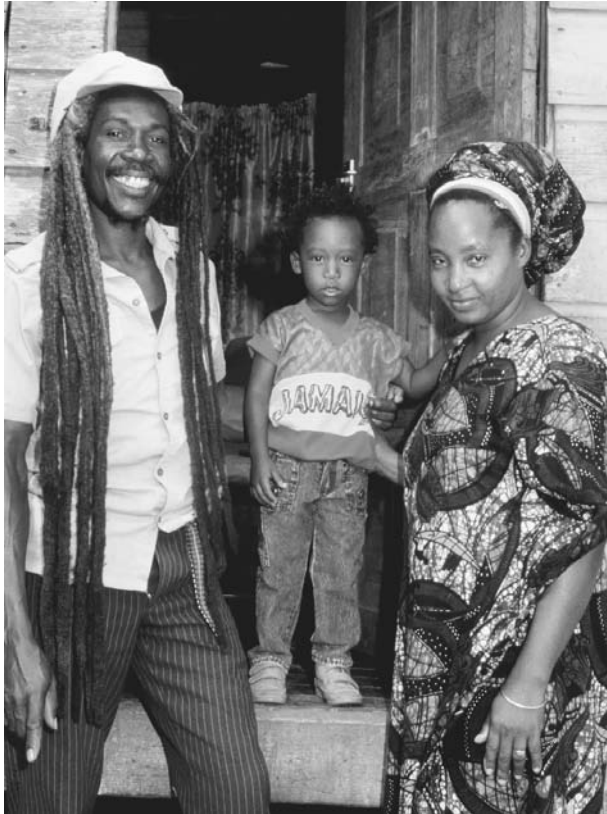

**Rastafarian family in Jamaica.** The distinctive clothing and hair-styles of Rastafarians constitute a fashion subculture. © DAVID CUMMING; EYE UBIQUITOUS/CORBIS. REPRODUCED BY PERMISSION.

different hooligan groups—the Manchester “Scuttlers” and the Birmingham “Peaky Blinders,” for example—there was adopted a quite distinct uniform of large boots, bell-bottomed trousers, a loosely worn muffler or scarf, and a peaked cap worn over a donkey-fringe haircut. The whole peculiar ensemble was set off with a broad, buckled, leather belt.

There were six or more intervening decades between the demise of the original “hooligans” and the emergence of the more familiar and clearly documented British youth subcultures of the post-1945 era—the teddy boys, mods, rockers, hippies, skinheads, and punks. Yet Pearson sees no fundamental difference between the way the Victorian gangs constructed clearly recognizable styles by appropriating elements from the range of fashionable sources available to them and the attempts by the more recent “spectacular” youth subcultures to create new, oppositional meanings through the recontextualization of raw commodities from the market—a process that the Centre for Contemporary Cultural Studies (CCCS) at the University of Birmingham, England, termed “bricolage.” Hence, the working-class teddy boys of the early 1950s appropriated the long laped neo-Edwardian drape suit from exclusive London tailors who aimed to bring back

the pre-1914 look for upper-class young men. But the teds combined this item with bootlace ties (from Western movies), greased-back haircuts, drainpipe trousers, and thick creped-soled shoes.

CCCS writers such as John Clarke and Dick Hebdige had adopted an analysis whereby subcultural styles were “decoded” or read as a text for their hidden meanings. Hence, the fastidious and narcissistic neatness of the mods, with their two-tone mohair suits, button-down collared shirts, and short, lacquered hair, could be interpreted as an attempt by young working-class people in menial and routine employment to live out on a symbolic level the affluent, consumerist, and classless aspirations of the early 1960s. By contrast, the skinheads who emerged later in the same decade typically sported very close-cropped hair or shaven heads, Ben Sherman shirts and suspenders, and short, tight jeans or sta-press trousers with Dr. Martens boots—a combination of elements that signified a “magical” desire to return to the puritan masculinity of a rapidly disappearing traditional proletarian lifestyle. By the end of the 1970s subcultural fashions had become less easy to decipher in this way. Hebdige, analyzing punk style in his classic text *Subculture*, was driven to assert that the punks’ “cut-up” wardrobe of bondage trousers, school ties, safety pins, bin liners, and spiky hair signified meaningfully only in terms of its very meaninglessness, as a visual illustration of chaos.

*American and Australian examples.* In Britain during the early 1960s, the natural enemy of the cool, clean-looking, scooter-riding mods were the leather- and denim-clad, insignia-decorated, greasy-haired rockers, or motorbike boys as Paul Willis called them, renowned for their macho, rock ‘n’ roll image and “ton-up” speeding runs on heavy-duty Triumph Bonneville. Yet the reputation of the British rockers was tame by comparison with the notoriety of the American “outlaw” biker gangs of the postwar era, the most famous of which were—and still are—the Hell’s Angels. Organized territorially in “chapters,” and espousing an ideology of personal freedom and conservative patriotism, the “Angels” rode their collective “runs” on “chopped hogs”—customized Harley-Davidson bikes. Their famous Death-Head emblem or logo, as described by Hunter Thompson, is a cloth patch embroidered with a biker helmet atop a winged skull, and a band inscribed with the words Hell’s Angels and the local chapter name. These “colors,” as they are known, are typically sewn to the back of a sleeveless denim shirt.

Heavy Metal is a rock music genre that has given rise to a virtually global fashion, arguably derived from a crossover of elements from biker, glam, and hippie culture. Headbangers or metalers, as they are known, are characterized by their typical dress of black T-shirt, often bearing a heavy metal band name, faded denim jeans, and a leather or denim jacket, perhaps decorated with various badges, patches, and band insignia. For both men





**The New Avengers.** The stars of the 1970s British television series *The New Avengers*, (from left to right) Gareth Hunt, Joanna Lumley, and Patrick McNee. McNee's character, John Steed, epitomized the style of the later-day Edwardian dandy. © HULTON-DEUTSCH COLLECTION/CORBIS. REPRODUCED BY PERMISSION.

and women, hair is usually long, the body or arms are often tattooed, and jewelry may be worn. The music itself has fragmented into various subgenres such as thrash-, death- and sleaze-metal, each with its own variant on the general metaler look. Jeffrey Arnett views young American metalheads (as they are named in the title of his book) as particularly prone to the alienation, anomie, and hyper-individualism that, from his point of view, characterize contemporary American youth more generally.

Because of the immense power of its market, and the dependence of subcultural fashions upon commodity production and consumption, styles originally developed or popularized in America have rapidly spread to other cultural contexts. In a chapter in Rob White's edited book on the Australian experience of youth subcultures, Stratton discusses the case of the 1950s bodgies and widgies—terms used to denote male and female members respectively. The style of the bodgie and widgies was originally jazz- and jive-oriented and loosely derived from the zoot suit (discussed below) worn by young black and Hispanic Americans in the 1940s. Later, however, this Aus-

tralian subculture became influenced by American biker culture and also began to incorporate elements from rock 'n' roll. Boys wore leather jackets or drapes with thin ties, drainpipe trousers, and winkle-picker shoes; girls had pencil skirts, stilettos or pedal-pusher shoes, and beehive or ponytail hairstyles.

### Neglected Dimensions and New Developments

**Gender and ethnicity.** In a chapter in *Resistance through Rituals*, Angela McRobbie and Jenny Garber noted that most of the subcultures and styles examined by the CCCS appeared overwhelmingly male in both composition and orientation. They concluded that girls *had* actually been present in such subcultures, but were rendered marginalized and invisible by the masculinist bias of the writers. It was only with the publication nearly a quarter of a century later of *Pretty in Punk*, Lauren Leblanc's noteworthy text on Canadian female punk rockers, that females in a male-dominated style subculture were studied comprehensively, in their own right



and on their own terms. Leblanc's sample displayed a range of punk signifiers, including hair brightly dyed and worn in a Mohawk style, facial piercings, tattoos, and the "street-" or gutter-punk look—dark, baggy T-shirts and trousers with black boots. Leblanc concludes that women's presence in a largely male punk subculture can be explained by the way their membership enables them to resist certain normative and stylistic aspects of fashionable (i.e. mainstream) femininity.

Although ethnicity, like gender, has been a relatively neglected dimension in the writings of subcultural style, the American "zooties" of the 1940s are one of the better-documented examples of black and Hispanic rebellious fashion. Derived from black, hipster jazz culture, the zoot suit comprised an oversized, draped and pleated jacket with hugely padded shoulders, worn with high-waisted, baggy-kneed and ankle-taped pants, often set off with a wide-brimmed hat worn over a ducktail hairstyle. During a period of wartime rationing of material, the wearing of such an extravagant, luxurious, and ostentatious style led to rising tensions between the young black and Hispanic male zooties and white U.S. servicemen, sparking off full-scale riots in a number of U.S. cities.

Within the British literature on subcultures, the ethnic dimension has been more typically viewed in terms of the effects of postwar British "race relations" and black style on the formation of indigenous rebellious youth fashions. A noted example of such an approach is Dick Hebdige's discussion of the Jamaican rude boy and Rastafarian subcultures. Elements from the first of these styles—the cool look, shades, porkpie hat, and slim trousers with cropped legs—fed first into 1960s mod and then the Two-Tone movement of the late 1970s. Rastafarians, to symbolize their oppression by white society (Babylon) and their prophesied return to Zion (Africa), have adopted knitted caps (called "tams"), scarves, and jerseys in red, gold, and green, the colors of the Ethiopian flag. It is, though, the Rasta's dreadlock hairstyle that has most significantly been taken up by certain groups of white youth, particularly new-age hippies and anarcho-punks, to show subcultural disaffection toward the dominant social order.

### Post-Modernism and Post-Subculture

The practice of borrowing ethnic signifiers has reached extreme proportions in the contemporary, transatlantic example of the Modern Primitive subculture. The chapter by Winge, in David Muggleton and Rupert Weinzierl's *The Post-Subcultures Reader*, details how this subculture with its largely white membership adopts aspects of so-called "primitive" tribal cultures, such as black-work tattoos, brandings, keloids, and septum piercings. While subcultural styles have typically been constructed by a borrowing of elements from other sources, this relocation of traditional elements in a modern, urban setting could be seen as a prime example of a tendency toward a more com-

plex cross-fertilization of time-compressed stylistic symbols in an increasingly global context. It is further argued that the identities fashioned from these diverse sources are themselves ever more eclectic, hybrid, and fragmented. Such a position has led some writers to proclaim that subculture—traditionally used to denote a coherent, stable, and specific group identification—is no longer a useful concept by which to comprehend these so-called "post-modern" or "post-subcultural" characteristics of contemporary styles.

That attempts at re-conceptualizing the term subculture, such as "neo-tribe," or "post-subculture," have proceeded on the terrain of post-modernism owes much to the American anthropologist Ted Polhemus. His *Streetstyle* is particularly worth singling out here, most obviously for its vividly illustrated genealogy of late-twentieth-century subcultures, from the 1940s zoot-suiters to the 1990s new-age travelers, but also for its attempt in the final chapters to conceptualize a new stage of development in the history of popular street fashion—"the supermarket of style." "Those who frequent the Supermarket of Style display...a stylistic promiscuity which is breathtaking in its casualness. 'Punks' one day, 'Hippies' the next, they fleeting leap across ideological divides—converting the history of street style into a vast theme park. All of which fits very neatly within postmodern theory" (Polhemus, p. 131).

Muggleton's *Inside Subculture* represents the first attempt to test such theoretical propositions about post-modern fashions. Using data from interviews with members from a range of subcultures, Muggleton generally agrees with post-modern claims concerning the fluidity, fragmentation, and radical individuality of dissident youth styles. He describes, for example, those such as the respondent with a Chinese hairstyle, baggy skateboarder shorts, leather biker jacket, and boots, whose eclecticism arguably leads them to disavow any affiliation to a group identity. Paul Hodkinson's *Goth* is a qualitative study of self-identifying members of the gothic subculture. Both male and female goths are noted for their dark and macabre appearance, typical features being black clothes, whitened faces, long, dyed black hair, plus dark eyeliner and lipstick. *Goth* differs somewhat from *Inside Subculture* in its stress on the continuing cultural coherence and stylistic substance of the British subcultural scene. Yet the potential reader is advised to seek out these two texts for their complimentary rather than conflicting assessments of the contemporary fashion subculture situation.

See also **Extreme Fashions; Punk; Retro Styles; Zoot Suit.**

### BIBLIOGRAPHY

- Arnett, Jeffrey. *Metalheads: Heavy Metal Music and Adolescent Alienation*. Boulder, Colo.: Westview, 1996.
- Hall, Stuart, and Tony Jefferson, eds. *Resistance Through Rituals: Youth Subcultures in Post-War Britain*. London: Hutchinson, 1976.

- Hebdige, Dick. *Subculture: The Meaning of Style*. London: Methuen, 1979.
- Hodkinson, Paul. *Goth: Identity, Style and Subculture*. Oxford: Berg, 2002.
- Leblanc, Lauren. *Pretty in Punk: Girls' Gender Resistance in a Boys' Subculture*. New Brunswick, N.J., and London: Rutgers University Press, 2002.
- Muggleton, David. *Inside Subculture: The Postmodern Meaning of Style*. Oxford: Berg, 2000.
- , and Rupert Weinzierl, eds. *The Post-Subcultures Reader*. Oxford: Berg, 2003.
- Pearson, Geoffrey. *Hooligan: A History of Respectable Fears*. London: Macmillan, 1983.
- Polhemus, Ted. *Streetstyle: From Sidewalk to Catwalk*. London: Thames and Hudson, Inc., 1994.
- Thompson, Hunter. *Hell's Angels*. New York: Random House, 1966.
- White, Rob, ed. *Youth Subcultures: Theory, History and the Australian Experience*. Hobart: National Clearinghouse for Youth Studies, 1993.
- Willis, Paul. *Profane Culture*. London: Routledge and Kegan Paul, 1978.
- Wilson, Elizabeth. *Adorned in Dreams: Fashion and Modernity*. London: Virago, 1985.

David Muggleton

**SUIT, BUSINESS** The man's business suit is an emblem of official power and professional identity, suggesting a life free from physical toil. The three-piece suit, allowing for differences of cut and fabric, has been the basis of the male wardrobe since the last quarter of the seventeenth century. King Charles II, on the restoration of the British throne in 1660, set the style for a new way of dressing. He appeared in a knee-length coat, vest (waistcoat), and breeches. As diarist Samuel Pepys recorded, "Oct 15th 1666. This day the king begins to put on his vest. It being a long cassock close to the body, of black cloth, and pinked with white silk under it, and a coat over it" (p. 324).

The loosely cut knee-length coat, embellished with elaborately worked buttonholes and deep turned-back cuffs, and embroidered waistcoat remained the staple of the British court style until the mid-1720s. As the British nobility spent much of their time on their country estates, the boundaries between the clothing of the landed gentry and the middle classes became eroded. Clothes that had originally been made for riding became upgraded into acceptable day wear and even for more formal occasions.

The influence of sporting dress increased an appreciation of the solid virtues of fit and finish. Throughout the eighteenth century, the comfortable and practical coat, waistcoat, and breeches, made mostly of wool, underwent little alteration. Abstaining from overt display was a requirement of the prevailing nonconformist reli-

gion, and together with the need for equestrian practicality this resulted in a movement away from baroque splendor to greater simplicity. By the 1780s this style of dress was correct for all but the most formal of occasions and obligatory court appearances. During the next twenty years, the coat became more streamlined and the turned-back cuffs, full coat-skirts, and pocket flaps began to be refined, with the waistcoat cut straight across the waistline. Legs were clad in knitted pantaloons, to provide a long, lean line in keeping with the desire to ape the natural masculine ideal of classical revivalism that was a significant aspect of dress at the beginning of the nineteenth century. This look was exemplified by George Bryan "Beau" Brummell, born in 1778, who established himself as a paradigm of sartorial exactness and simplicity. A close friend of the Prince of Wales, who became Regent in 1811 and later George IV, Brummell created a vogue for bespoke tailoring. He took his patronage to the Burlington estate where fashionable tailors had begun to congregate in the late eighteenth century.

By 1806 the first tailor was established in Savile Row. By 1810 tailoring techniques were capable of producing an unembellished coat of exquisite fit with emphasis on sculptural seaming and construction. The coat now had a collar that curved around the neck and formed flat lying lapels across the chest, the most distinctive element of the modern-day suit. The perfect fit was also due to the use of woolen cloth, which is both pliable and responsive to steam pressing, unlike the taut weave of silk. Wool was also easily available, a staple cloth of England's sheep farmers. Ready-made clothes were available from the 1820s, and with the development of the railroads and the opening of department stores they came to dominate the market, though bespoke tailoring remained standard wear for the middle and upper classes. Secondhand merchants provided clothes for the poor, and hawkers redistributed redyed patched clothing at markets.

In 1815 trousers, very often looped under the foot, replaced pantaloons and were worn with the frock coat, which owed its origins to the military greatcoat. First appearing in 1816, it was the most usual coat for daywear, typifying middle-class respectability as it was worn by the professions and by businessmen. Buttoned from neck to knee it was decorated across the chest with frogging. By 1850 the morning coat was preferred. Based on the riding coat, (riding was a popular morning activity) it began to be worn on formal occasions, replacing the frock coat, and by 1900 it was the established norm for business and professional activities.

The nineteenth century saw an increasing division between the public and private roles for men and women. The psychologist J. C. Flügel identified the early nineteenth century as era of "The Great Masculine Renunciation," when men became more concerned with propriety than with the pleasures of adornment. This supposition that men gave up their right to a choice of elaborate clothing, leaving the pleasures of ornamentation only to

women, can be countered by the many different masculine styles that developed at that time. For example, the Paletot was introduced in the 1830s. This was a jacket, cut loose and without a waist seam; it came to denote a certain bohemianism. Refined by the 1850s into the lounge jacket, and worn with matching waistcoat and trousers, it became the lounge suit and was initially worn after lunch and only in private, never on formal occasions or in the city. However, city workers were wearing ready-to-wear versions in darker colors, and by 1920 it assumed respectability and was subsequently worn for all business events. It became the all-purpose male costume of the twentieth century.

Advances in technology made possible the production of men's suits in large quantities, standard sizes, and a wide range of price points, thus helping to ensure the suit's continuing popularity over a long span of time. During the middle decades of the twentieth century, suiting materials became lighter in weight, reflecting the widespread use of central heating in homes and workplaces.

After World War II, men's wear became more casual and youthful in appearance; in America, the collegiate "Ivy League Look" became dominant. Also influential was the Italian streamlined silhouette developed by tailors in Rome and Milan. Italian and American suits influenced British tailoring in the 1950s and 1960s, just as London was becoming the center of youth fashion. John Stephen opened the first of his men's wear shops in Carnaby Street, purveying styles that were colorful, cheap, and fun. The clothes presaged the look of the hippie era in the use of richly textured and colored materials and exploitation of historical revivalism. The response of traditional male outfitters was to attempt to offer suits with some of the eccentricities of Carnaby Street but allied to something suitable for business wear. In 1965 men's outfitter Austin Reed filled the gap between Carnaby Street and traditional tailoring, providing contemporary suits for the young executive. Male-orientated publishing ventures such as *Man About Town*, which was first published in 1961, (subsequently called *About Town* and then simply *Town*) placed shopping for fashion firmly in the context of a leisure activity. The bespoke end of the market was not immune to change. Tommy Nutter, defined by the style press as a "designer tailor," took over premises on Savile Row and combined traditional qualities of craftsmanship with excessive detailing.

The 1970s and 1980s saw the rise of Italian luxury ready-to-wear. Giorgio Armani, in particular, became known for his unstructured suits, which combined ease and elegance, thus linking the freedom of the 1960s with the drive for financial success that typified much of 1980s culture. The revival of the suit heralded a new seriousness about being successful, epitomized by the aspirational "yuppie." The burgeoning style press and the advertising industry emphasized the importance of a lifestyle that included not only clothes but also iconic ac-

cessories such as the Rolex watch and the Mont Blanc fountain pen. The newly important role of the merchandiser, rather than the buyer or designer, underpinned the emphasis on lifestyle marketing. Men's shops took on the appearance of a gentleman's club. Retailers such as Ralph Lauren and Paul Smith sold the "English look" amidst the accoutrements of an Edwardian gentlemen's club such as sofas, leather-bound books, and sports paraphernalia, all evoking an era of leisured gentility.

When women entered the marketplace in substantial numbers in the 1980s, they began to adopt elements of male dress, wearing an approximation of the male suit. As they achieved more confidence they exaggerated the tailored qualities of the suit with ever widening shoulders and flying lapels, subverting its formality with short skirts and stiletto heels, a look known as "power dressing."

Despite a long-term trend toward more casual dressing, the suit remains an icon of authority. However its details might vary, it remains fundamentally the same. The business suit implicitly evokes the virtues of assertiveness with self-control, diffidence in success, and just enough socially acceptable narcissism to be attractive.

See also **Armani, Giorgio; Flügel, J. C.; Lauren, Ralph; Tailored Suit; Trousers.**

#### BIBLIOGRAPHY

- Breward, Christopher. *The Hidden Consumer: Masculinity, Fashion, and City Life*. Manchester: Manchester University Press, 1995.
- Chenoune, Farid. *A History of Men's Fashion*. Paris: Flammarion, 1993.
- Hollander, Anne. *Sex and Suits*. New York, Tokyo, and London: Kodansha International, 1994.
- Kuchta, David. *The Three-Piece Suit and Modern Masculinity: England, 1550–1850*. Berkeley, Los Angeles, and London: University of California Press, 2002.
- Latham, R., and W. Matthews, eds. *The Diary of Samuel Pepys*, Vol. 7. New York: Harper Collins, 1995.

Marnie Fogg

**SUMPTUARY LAWS** Sumptuary laws can be dated to at least the fourth century B.C.E., and while they have largely disappeared in name, they have by no means disappeared in fact. By definition, they are intended to control behavior, specifically the excessive consumption of anything from foodstuffs to household goods. By convention, they have come to be largely associated with the regulation of apparel, their most frequent target. Typically, those issued by executive or legislative entities—and that are thus laws in the legal sense—have lasted no more than a few decades before being repealed or annulled. Infinitely more enduring have been extra-legal pronouncements that codify social or religious precepts, such as the injunction against garments woven of wool and linen proclaimed in Leviticus 19:19 and still obeyed by Orthodox



Jews. (The longevity of restrictions on women's dress issued by modern theocracies remains to be seen, now that these have passed from custom into law.)

### Types

Sumptuary regulation is of two general types: prescriptive and proscriptive. The first defines what people must purchase, wear, or use, the second what they may not. Although both approaches limit choice, proscriptive laws can be seen as less onerous in so far as individual freedom is concerned since they imply acceptance of anything not expressly forbidden.

### Goals and Outcomes

Personal liberty is never a factor in such legislation; however, actual statutes are written to address any of a number of sociocultural objectives deemed important by the issuing authority. Rulings in effect between 1337 and 1604 in medieval and renaissance England, for example, reflect multiple (and by no means mutually exclusive) goals: resisting new fashions, protecting public morals, preserving the public peace, maintaining social distinctions, and—extremely important to this commercial nation—defending the domestic economy and promoting home industries. Across the Channel, particularly in Protestant countries, sumptuary laws were more likely to assume the deity to be as offended by sartorial choices as was the government. Here, one might compare an English statute of 1483, which banned without explanation the stylishly short gowns that failed to mask “privy Members and Buttocks” (*Statutes of the Realm*, p. 22) with a Bavarian injunction that prohibited uncovered codpieces because these were offensive to God. After the conclusion of the Thirty Years War in 1648, however, the sumptuary laws of the German states began to resemble those of England in their emphasis on economic issues.

One of the intended outcomes of much sumptuary law is that of separation, the division of people into explicit categories. Modern examples tend to differentiate by religion, whether by choice (the Amish cap) or by coercion (the yellow star). In earlier times, a populace was more likely to be divided by class than by creed; and in hierarchical societies in which ritualized honors were due those of superior rank, status had to be readily recognizable if people were neither to insult their betters (by failing to offer the proper marks of respect) nor embarrass themselves (by extending undeserved courtesies to those beneath them).

### Parameters

The desire for upward mobility may be both innate and unquenchable; however, much of sumptuary legislation is concerned with defining the degrees of rank and wealth that govern the wearing of metals, textiles, colors, decorative techniques, furs, and jewels. Limitations on gold, silks, purples, lace, embroidery, sable, and precious stones are, thus, recurring elements, as are injunctions against

certain fashions (including short robes, long-toed shoes or *poulaines*, and great hose) considered unacceptable for moral, patriotic, or economic reasons. Improving economies raised not only the earnings but also the aspirations of, especially, the merchant classes, however, and England was not unusual in its continuing reformulation of vestimentary prohibitions relative to disposable income. While the threshold most commonly cited in English law is £40, in 1337 Edward III limited the wearing of furs to those with a disposable income of at least £100, and in 1554 Queen Mary lowered the minimum for silk to £20 (although she also insisted on a net worth of £200, an amount reiterated in a Massachusetts law of 1651).

### Penalties

Most sumptuary legislation provides penalties for lawbreakers that could include confiscation of the offending garment, fines (up to £200 in England), tax auditing, the pillory, or even jail. That legislators were themselves subject to (and breakers of) these statutes may help to explain both their lax enforcement and their frequent repeal. In England, at least, lack of compliance was so general that in 1406 Henry IV vainly requested that violators be excommunicated. In 1670, women who used dress and cosmetics to “betray into matrimony any of his majesty's subjects” (Geocities.com Web site) were to be punished as witches.

### Women

As might be expected, the attention paid to women in sumptuary law varies with time and country, and does so in ways that reflect their place in society. Generally speaking, early modern sumptuary legislation treats women in one of four ways: it exempts them specifically or ignores them completely (implying that women were of no consequence); or, conversely, it subjects them either to the same requirements as men or to parallel requirements (implying that women were not to be disregarded). There are of course exceptions. A few statutes imply fear of gender confusion. In the third century C.E., for example, the emperor Aurelian barred men from wearing shoes of yellow, green, white, or red since these colors were reserved for women. Others were aimed at keeping women in the home, as did an edict enacted in Rome in the second century B.C.E., that forbade their riding in a carriage in or near populated areas. More (both written and unwritten) were intended to keep them modest—Hebrews, Romans, early Christians, and early Americans alike mandated simplicity in feminine hairstyles, clothing, and accessories. Perhaps not surprisingly, prostitutes received special attention, as did courtesans, who, finding their consorts among the nobility, rather naturally rivaled well-born women in their dress. From at least the thirteenth century onward, European prostitutes were commonly enjoined to wear some form of distinctive clothing, whether striped hoods, striped stockings, colored patches, or bells (interestingly, such markers were prescribed for other social outcasts, among them lepers and Jews).

**Summary**

Collectively, sumptuary laws reflect a need for permanence that is shared by governments, religions, and smaller societal groups alike. That so many have been written and so few endure speaks to the fundamental dissonance between the institutional need for stability and the personal desire for independence.

See also **Colonialism and Imperialism; Europe and America: History of Dress (400–1900 C.E.)**

**BIBLIOGRAPHY**

- Baldwin, Frances Elizabeth. *Sumptuary Legislation and Personal Regulation in England*. Vol. 44. *Johns Hopkins University Studies in Historical and Political Science*. Baltimore: The Johns Hopkins Press, 1926.
- Benhamou, Reed. "The Restraint of Excessive Apparel: England 1337–1604." *Dress* 15 (1989), 27–37.
- Great Britain. *Statutes of the Realm*. London: 1890. Reprint, London: Dawson, 1963.
- Vincent, John Martin. *Costume and Conduct in the Laws of Basel, Bern, and Zurich 1370–1800*. New York: Greenwood, 1969. Original edition published in 1935.

*Internet Resource*

- Geocities.com. "Platform Shoes of the 1600s." Available from <<http://www.geocities.com/FashionAvenue/1495/1600.html>>.

*Reed Benhamou*

**SUNGLASSES** Sunglasses, spectacles with tinted lenses, were originally a purely practical safety device, designed to protect the eyes from excess sun and glare. In the twentieth century, however, they became an important fashion accessory, whose use and meaning continues to evolve.

**Sun Glasses to Sunglasses**

Tinted spectacles were made in Europe as early as the seventeenth century, but were used because they were thought to be beneficial to the eyes, or to conceal the eyes of the blind, and were not "sunglasses" in the modern sense. The need for eyewear to protect the eyes against sun and glare first became apparent in the mid-nineteenth century, when early polar explorers and high-altitude mountaineers experienced snow-blindness, and spectacles and goggles with tinted lenses were developed, some with side shields of glass or leather. (The Inuit used slit snow-goggles of wood or bone, which covered the eyes.) As increasing numbers of Europeans and Americans were exposed to the strong sun of tropical and equatorial colonies and territories, dark glasses began to be worn there as well.

Sunglasses became more widely available in the 1880s, when bathing and holidays by the sea became popular with the general public; by 1900, inexpensive tinted glasses (now known as "sun glasses") were sold by seaside vendors, and worn by English tourists in Egypt to

reduce the desert glare. The invention of the automobile, and the popularity of motoring as a fashionable leisure activity, also brought protective eyewear into common use, and tinted motoring goggles were available by the 1910s.

**Hollywood Style and Glare Control**

In the 1920s, sunglasses were occasionally worn for active outdoor sports such as golf and tennis, and for the newly fashionable activity of sunbathing. They did not truly enter the fashion sphere, however, until the early 1930s, when Hollywood stars such as Bette Davis and Marlene Dietrich were photographed wearing them between takes on the set, attending tennis matches and horse races, or trying to appear in public incognito. Sunglasses began to symbolize the glamour of life in Hollywood, but there was little variation in style at first; most 1930s sunglasses, for both men and women, had round, flat glass lenses, with narrow celluloid frames. The only fashion decision lay in choosing the color of the frames; these were usually translucent and in colors close to tortoiseshell, but opaque white frames were also considered chic.

Toward the end of the decade, the demand for sunglasses, and the variety of available styles, increased dramatically; in 1938 the number of pairs sold went almost overnight from the tens of thousands into the millions, and manufacturers rushed to come up with new colors and styles. Sunglasses began to be shown with street clothes, in addition to ski and beach wear, and *Vogue* suggested styles, such as the white pair featured on the cover of the 1 August 1939 issue, with "wide rims and ear-pieces, giving the approved 'goggly' appearance" (p. 81). Sunglasses, being less expensive than prescription eyewear, and associated with vacation and leisure activities, were quickly embraced as a "fun" fashion accessory, and even bizarre novelty styles soon found a market.

The quality of sunglasses also improved in the 1930s, and both of the major U.S. optical companies introduced lines of sunglasses with optical glass lenses (ground and polished like prescription eyeglasses). Taking advantage of the public appeal of daring aviators such as Charles Lindbergh and Amelia Earhart, Bausch & Lomb introduced the metal-framed "Anti-Glare Aviator" sunglasses in 1936, and the following year gave them the more appealing brand name "Ray-Ban" (to emphasize protection from harmful infra-red and ultraviolet rays). American Optical teamed up with the Polaroid Corporation in 1938 to produce the first polarized sunglasses, with glass lenses incorporating a polarizing film. World War II brought new popularity to military-style sunglasses, especially Ray-Ban Aviators (worn by Navy pilots and General Douglas MacArthur), and lent them the air of toughness and competence that has kept the style popular ever since.

**To See and Be Seen**

After the war, the craze for sunglasses quickly resumed in full force. Advertisements began to emphasize smart

styling over eye protection, and distinct men's and women's styles were developed. Sunglasses could now be purchased in drug, variety, and department stores, at prices from 25 cents to 25 dollars. With growing competition, established manufacturers increased their advertising and diversified; American Optical launched the "Cool-Ray" trademark, and in 1948 introduced inexpensive Polaroid plastic lenses. It became fashionable to have multiple pairs for sport, everyday, and even evening wear, and in colors to match particular outfits. Eyeglass wearers could have sunglasses made with their prescription, or choose from a variety of clip-on styles.

In the 1950s, to boost sales, sunglass manufacturers began coming out with new models every year, following the lead of the automobile industry. As with eyeglasses, the harlequin, or "cat-eye," shape was the dominant style for women, but sunglasses took the style to much more fanciful extremes. Sunglasses were made with carved, laminated frames shaped like flames, flowers, and butterflies, studded with rhinestones, imitating unlikely materials like bamboo, or trimmed with false "eyelashes" of raffia. Even relatively conservative frames were produced in bold and unusual shapes, colors, and patterns, and were given model names such as "Torrid," "Vivacious," and "Peekini." For men, new styles with clean lines and heavy plastic frames were popular, the most famous being the Ray-Ban "Wayfarer," introduced in 1952.

Whatever the frame style, sunglasses were also worn because of the air of mystery they imparted to the wearer. One could still hope to be mistaken for a celebrity such as Grace Kelly or Rita Hayworth, but sunglasses also offered, as a 1948 ad for the first mirrored sunglasses put it, "the wonderful fun of looking out at a world that can't see you" (Saks 34th St. advertisement for "Mirro-Lens" sunglasses, *New York Times*, 28 March 1948, p. 30). Dark "shades" contributed considerably to the "cool" of bebop jazz musicians and beatniks, who wore them even in dark nightclubs. Once the fad for wearing sunglasses at night caught on, however, it became harder to tell the "hip" from the "square"; as one observer told the *New York Times* in 1964, "If you're really 'in' you wouldn't be caught dead wearing them indoors or at night because you'd look like someone who is 'out' but is trying to look 'in'" (Warren, p. 66).

By the early 1960s, sunglasses were more popular than ever, with an estimated 50 million pairs per year sold in the United States by 1963. They were also available in more styles than ever before; Ray-Ban advertised "the see and be-seen sunglasses, [in] all kinds of designs—bold, shy, classic, crazy, round, oval, square, oriental" (Evans, p. 17). President Kennedy often appeared in public wearing sunglasses, and Jacqueline Kennedy started a fad for wraparound sunglasses when she began wearing them in 1962. Similar sleek, futuristic styles from Europe inspired Polaroid to launch the French-sounding C'Bon brand,



**Women model the latest fashions in sunglasses in California, 1941.** Sunglasses first became popular as a fashion accessory in the 1930s. By the 1940s they were beginning to be offered in a variety of styles, some of them quite fanciful, such as the sunflower-shaped frames at the bottom right. © BETTMANN/CORBIS. REPRODUCED BY PERMISSION.

featuring "the St. Tropez look." Sunglass advertising was also taken to new and imaginative heights; the famous "Who's that behind those Foster Grants?" campaign of the mid-1960s, in which celebrities such as Vanessa Redgrave and Peter Sellers were shown transformed into a series of exotic characters by Foster Grant sunglasses, were highly successful in promoting the power of sunglasses to "subtly alter the personality," (Foster Grant advertisement, 1964, available from [www.fostergrant.com](http://www.fostergrant.com)) and release the wearer's inner tycoon or femme fatale.

In 1965, André Courrèges's sunglasses with solid white lenses and viewing slits were the first designer sunglasses to receive wide attention. They soon inspired other space-age designs such as Sea-and-Ski's "Boy-watcher," a seamless slit goggle that could also be worn as a headband, and a variety of alien-looking "bug-eye" styles, with frames in day-glo colors or shiny chrome. So-called "granny glasses" were also popular, as were large round wire-rims with lenses in pale psychedelic tints. Enormous round dark glasses, such as those designed by Emilio Pucci, were another style favored by celebrities late in the decade.



In the 1970s, the trend toward oversized designer frames continued. In keeping with the fashionable “natural” look, lenses became paler, with gradient tints in the same rosy shades fashionable for eye makeup. The eyes were now visible, and in the April 1977 issue of *Vogue* sunglasses were declared “the new cosmetic” (p. 146). As the decade progressed, expensive sunglasses by designers such as Pierre Cardin and Givenchy became sought-after status symbols, and were frequently worn on top of the head like a headband when not in use. Sporty mirrored styles were also popular, especially for men.

### New Optical Identities

In the early 1980s, the trend to harder-edged styles in black and bright colors coincided with the revival of Ray-Ban’s Wayfarer style, which was given a high profile by the Blues Brothers, the 1983 film *Risky Business*, and the TV series *Miami Vice*. Heavy black sunglasses with conspicuous designer logos harmonized with the era’s penchant for “power dressing,” and similar flashy styles were reproduced for every price range. Oddly shaped, futuristic “new wave” styles were another trend, and the mirrored aviator style was revived once again by the 1986 film *Top Gun*. High-tech “performance” styles designed specifically for outdoor sports, by makers such as Vuarnet and Revo, first became popular in the 1980s, and started a craze for iridescent mirrored lenses.

In the late 1980s and 1990s, in sunglasses as in eyeglasses, minimalism, industrial design, and revivals of earlier styles were the dominant themes. Designer logos fell out of favor early in the decade, and pared-down fashion and hairstyles required clean-lined, sleek frames with meticulous detailing. New sports styles by Oakley, so close-fitting that they seemed to merge with the face, were popularized by athletes such as Michael Jordan and Olympic speed-skater Bonnie Blair. These high-tech glasses, using novel materials such as magnesium alloy and gold iridium, were highly influential, and began to blur the line between sports and fashion eyewear.

At the turn of the century, sunglasses are more important than ever as an individual fashion statement, but there is no dominant style, unless it is “freedom of choice.” After a series of “retro” revivals, and trends started by musical celebrities, avant-garde designers, athletes such as Lance Armstrong, the NASCAR circuit, and films such as *The Matrix*, the sunglass market has fractured into many specialized niches. An unprecedented variety of designer collections is available to choose from in the early 2000s, and larger makers such as Ray-Ban feature several smaller “themed” collections, each with its own distinct aesthetic. Over the course of the twentieth century, sunglasses have become an essential part of the fashion and image-making vocabulary, and they seem likely to continue to fill this role in the future.

See also **Eyeglasses**.

### BIBLIOGRAPHY

- Baker, Russell. “Observer—New Upward Movement in Clothing.” *New York Times* (16 June 1964): 38.
- Evans, Mike, ed. *Sunglasses*. New York: Universe, 1996. Brief, popular introduction.
- Warren, Virginia Lee. “Dark Glasses After Dark: For the Eyes or Ego?” *New York Times* (10 Dec. 1964): 66.

### Internet Resources

- Foster Grant. “Foster Grant History.” Available from <<http://www.fostergrant.com/history.html>>.
- Ray-Ban. “Ray-Ban History.” Available from <<http://www.rayban.com>>.
- Whitman, Anne. “Retro-Specs.” *Eyecare Business*. December 1999. Available from <<http://www.eyecarebiz.com>>.

Susan Ward

**SUPERMODELS** “Supermodel” ranks with “genius” and “original” as one of the most-abused terms in the fashion lexicon. Indeed, it has been so overused that by the late 1990s, when the Supermodel phenomenon (personified by larger-than-life mannequins such as Cindy Crawford, Claudia Schiffer, Naomi Campbell, and Christy Turlington) had long-since peaked and passed, the word had lost almost all meaning, becoming a generic gossip-column descriptive promiscuously pinned on almost any fashion model with, or in some cases, merely wanting, a public profile.

Though many claimed to have coined the term, notably the 1970s model Janice Dickinson, the first recorded use of the word was in a 1948 book, *So You Want to Be a Model!* by a small-time model agent named Clyde Matthew Dessner. It came into more general usage in 1981, when *New York* magazine published “The Spoiled Supermodels,” in which Anthony Haden-Guest, the incisive British journalist, chronicled the myriad misbehaviors of highly paid models and photographers in the cocaine-clouded world of post-Studio-54 New York City.

In pure terms, there had been supermodels long before that—at least, if supermodels are defined, as they properly should be, as mannequins whose renown and activities stretch beyond the bubble-world of fashion.

Supermodels don’t just look the part—they have to live it. The earliest one was probably Anita Colby, who began her career in the 1930s as a model with the Conover Agency in New York, but was soon lured to Hollywood where, in 1944, she served as ringleader of a gang of models who co-starred with Rita Hayworth in the big-budget film, *Cover Girl*. Colby’s success in publicizing the film—she arranged an average three magazine cover stories per cover girl—won her a job as image consultant for the great producer, David O. Selznick, an appearance on the cover of *Time* magazine, a recurring spot on the *Today Show* (where a young Barbara Walters



**Designer Gianni Versace and supermodels.** Fashion designer Gianni Versace stands amidst models (From left: Unknown, Unknown, Shalom Harlow, Linda Evangelista, Kate Moss, Naomi Campbell, Amber Valletta) for his autumn-winter 1996–1997 haute-couture collection. © PHOTO B.D.V./CORBIS. REPRODUCED BY PERMISSION.

wrote her scripts), and marriage proposals from Clark Gable and James Stewart.

The 1940s and 1950s were dominated by the supermodel sisters Dorian Leigh and Suzy Parker. Leigh, the older sister, lived large; she had affairs with Harry Belafonte, Irving Penn, and the Marquis de Portago, and a two-day marriage to drummer Buddy Rich; she founded two modeling agencies, and gave Martha Stewart her first job when she owned a catering business. Sister Suzy Parker, best known as photographer Richard Avedon's muse, was also a gossip column staple and a Hollywood star before she settled into domesticity as the wife of actor Bradford Dillman.

The next generation of supermodels was led by Britons Jean Shrimpton and Twiggy. Shrimpton had the good fortune to hook up with David Bailey, the best of a batch of trendsetting British photographers known as the Terrible Trio, just as the 1960s were getting started. She was a pouty-lipped, saucer-eyed, eighteen-year-old modeling school graduate; he was a twenty-three-year-old East End rake-in-the-making. Together, they kicked off the Youthquake before he went on to marry actress Catherine Deneuve, and she to an affair with actor Terence Stamp and an appearance on the cover of *Newsweek*.

A year later, The Shrimp was replaced by a Twig, or rather Leslie Hornby, a.k.a. Twiggy, who catapulted to worldwide fame (and another *Newsweek* cover) with the help of a hairdresser at Vidal Sassoon who called himself Justin de Villeneuve. Twiggy was the first model to gain a profile outside fashion before making the jump into film. But she was also a comet—by 1968, she'd burned out. In 1971, she made a comeback as an actress, but despite some success, never again saw super-stardom. "I used to be a thing," she said in 1993. "I am a person now" (Gross, p. 183).

By then, of course, many other women had donned the rainments of the supermodel, only to be disrobed by a public eager for the next new...thing. Thanks to a lift from *Sports Illustrated's* swimsuit issue, Cheryl Tiegs revived the poster girl, and the supermodel phenomenon, when she crossed over from fashion into the worlds of the pinup and then the eponymous product marketer—a trajectory many wanna-be "supes" would follow thereafter. Hers wasn't the only path to stardom. Janice Dickinson made it by doffing her clothes at every opportunity, Iman by hooking up with the socialite photographer Peter Beard, who billed her as fresh out of the African bush, even though she was the educated daughter of a diplomat.



**Supermodels.** Naomi Campbell, Elle MacPherson, and Claudia Schiffer (left to right) pose for a picture at the opening of New York's Fashion Café in 1995. These women, and a few other top models, are known as supermodels on account of their celebrity status. © MITCHELL GERBER/CORBIS. REPRODUCED BY PERMISSION.

Christie Brinkley parlayed her moment into several decades, and in the early 2000s is a star-billed political activist. Patti Hansen and Jerry Hall married Rolling Stones and became celebrities through sexual association. But that path to staying power didn't always lead to the same destination. After Elaine Irwin married rocker John Mellencamp, she fell from view, apparently content to be a wife and mother.

Irwin was one of ten supermodels photographed for *Harper's Bazaar* by Patrick Demarchelier in 1992, the peak of Supermodeldom. With her in the picture were Christy Turlington, Cindy Crawford, Naomi Campbell, Linda Evangelista, Yasmeen Ghauri, Karen Mulder, Claudia Schiffer, Niki Taylor, and Tatjana Patitz. Along with Helena Christensen, Stephanie Seymour, and later, Kate Moss, this baker's dozen formed the core of the real Supermodel Corps, aided and abetted by image-conscious designers such as Karl Lagerfeld, Calvin Klein, and Gianni Versace, photographers such as Patrick De-

marchelier, Peter Lindberg, and Steven Meisel, and the Parisian model agent Gerald Marie. All of their behind-the-scenes machinations helped create the supermodel moment.

Each, in his own way, had seen a window of opportunity open in 1987, when fashion's excesses of the preceding ten years, followed hard by a stock-market crash on Wall Street, and a worldwide recession, put an end to the designer decade that had been launched along with Calvin Klein jeans back in the pre-super 1970s. When the pouf dress—symbol of those heady days—went pop, the air went out of fashion and designers lost their way, just at the moment when the mass market seemed to have discovered them. The supermodels were used as a placeholder, a distraction, a way to keep the attention of the audience focused on fashion, while behind the scenes, the designers scurried around looking for a new message better suited to their times and their greatly expanded audience. Only problem was the supes soon became the tail that wagged the dog of fashion.

But truth be told, they couldn't sustain their "suzerainty." By 1995, the public had tired of the supes and were ready for something, anything, else. The fashion business was tired of them, too. They were too demanding, too expensive (Evangelista had famously remarked that she wouldn't get out of bed for less than \$10,000; by 1995, that price had risen to \$25,000), too overexposed. The shelf life of models is generally seven years. The supermodels were pert nose up against their use-by date. "I won't use her," as designer Todd Oldham said of Campbell, then the worst behaved of the lot (Gross, p. 438).

In 1996, just in time, a new model movement came along. The small, unassuming girls who were newly in favor were called waifs, and they dressed in a style with the unappealing name, grunge. Unfortunately, although it did take to Kate Moss, the last of the era's supermodels, the public didn't go along with the rest of the trend, and soon enough a new crop of larger-than-life models appeared. But fashion had been downsized—and they were too. Amber Valletta and Shalom Harlow made a run for the top but fell short. In their wake came other girls (for that's what the business calls them, even though they are its representation of womanhood), but few supes. Had you asked a boy tossing a football in Indiana to name the supermodels of 2003, he would probably say Gisele Bundchen and Heidi Klum (both stars of the ad campaigns run by Victoria's Secret, which replaced *Sports Illustrated's* bathing suit issue as the source of all fashion knowledge for American men)...and then he would pause, searching for more names but not finding them.

Which means that as surely as long hems follow short ones, the time is probably nigh for the return of the supermodel.

See also **Fashion Models; Grunge; Twiggy.**



## BIBLIOGRAPHY

- Conover, Carole. *Cover Girls: The Story of Harry Conover*. Englewood Cliffs, N.J.: Prentice-Hall, 1978.
- Gross, Michael. *Model: The Ugly Business of Beautiful Women*. New York: William Morrow, 1995.
- Leigh, Dorian, with Laura Hobe. *The Girl Who Had Everything: The Story of "The Fire and Ice Girl."* Garden City, N.Y.: Doubleday, 1980.
- Moncur, Susan. *They Still Shoot Models My Age*. London: Serpent's Tail, 1991.
- Sims, Naomi. *How To Be A Top Model*. New York: Doubleday, 1989.

Michael Gross

**SWEATER** The knitted sweater is a staple garment of everyday clothing, being functional, versatile, and fashionable. The hand-knitted "shirts" and "waistcoats," worn as underclothing by both rich and poor from the seventeenth century, can be linked to the "gansey" or "jersey" worn by fishermen and sailors of the British Isles and Scandinavia from the mid-nineteenth century. With the emergence of machine production, the functional, fitted woolen sweater was adopted for sailors' uniforms in 1881, and continues as standard issue for navy and army personnel into the early 2000s.

By the end of the nineteenth century, fashionable clothing had become more relaxed as outdoor and leisure pursuits grew in popularity, cumbersome multiple layers reduced, and knitted underwear transformed into outerwear. Fashionable young men increasingly took up sports activities, and the masculine "sweater" (a close-fitting, knitted undergarment for absorbing sweat generated by exercise) was soon adopted by women.

The growing emancipation of women saw their participation in sports such as golf, tennis, and cycling, and, together with the bifurcated "bloomer," the fitted sweater formed an outfit which gave unprecedented freedom of movement. The publication of instruction booklets for knitting designs fostered the rapid spread of new sweater fashions.

The evolving forms of the sweater have become symbolic of their time. During the 1920s and 1930s, key events influenced the sweater in fashionable dress: Coco Chanel's use of knitted jersey fabric (inspired by men's sweaters) for relaxed but sophisticated style; the Fair Isle patterned pullover worn by the Prince of Wales; Elsa Schiaparelli's famous trompe l'oeil hand-knitted sweaters; and the jazz age of F. Scott Fitzgerald and *The Great Gatsby*. The jumper-knitting craze that followed World War I's "knitting for victory" inspired several popular songs. Long lean "jazz jumpers" (both homemade and store bought) helped to define the softer, boyish silhouette of the "flapper" era.

The intricate tailored hand knits of wartime thrift; the glamorous styles and provocative image of the Hollywood

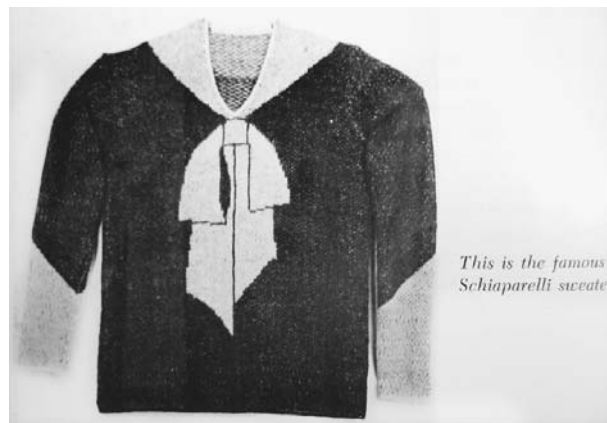

**Schiaparelli sweater.** The sweater is a versatile garment that has been adapted for a wide variety of fashions. Elsa Schiaparelli's "bow-knot" sweater was a hit in 1920s America and stands as one of her most famous designs. FROM "SHOCKING LIFE" BY ELSA SCHIAPARELLI, COPYRIGHT 1954 BY ELSA SCHIAPARELLI. USED BY PERMISSION OF DUTTON, A DIVISION OF PENGUIN GROUP (USA) INC.

"sweater girls" of the 1940s; golfing argyle-patterned sweaters, and the twin set of classic sophistication, (produced, for example, by Pringle of Scotland), have all become standards. The black polo-neck sweater of the avant-garde and the beatnik's "sloppy Joe" mohair sweater of the 1950s; the growth of Italian style and casual wear in the 1960s, and the ravaged punk sweater of the 1970s, have also become iconic.

Pioneered by British designers such as Patricia Roberts, Artwork, and Joseph, the craft revival of the 1970s and 1980s transformed the hand-knitted sweater with multiple colors, pictorial or graphic patterning, and intricate stitchery. "Designer knitting" strongly influenced the development of technology for more complex mass-produced sweaters. In Europe, Missoni and Kenzo applied new color, texture, and proportion to high-fashion sweater dressing, exploiting jacquard technology to the fullest. Krizia created a popular range of animal-patterned sweaters that became a signature in each successive collection. Sonia Rykiel, Vivienne Westwood, and later Clements Ribeiro recolored traditional sweaters in stripes and argyle pattern variations. By the mid 1990s, the knitwear designs of Missoni and Rykiel were again popular as revival fashion reinterpreted earlier periods. At the more commercial end of the fashion spectrum, Benetton focused on color and universal appeal for its low-priced knitwear, which, through global branding and retailing, made basic knitwear accessible, fashionable, and fun. In the twenty-first century, a wide range of machine-made sweaters regularly feature in high-fashion collections of such as Prada, Armani, and Donna Karan. Oversized, dramatic, and elaborate hand-knitted sweaters are a focus of Dior, Gaultier, and Alexander McQueen couture collections. As knitting technology advances, the

sweater remains integral to fashion and a basic garment capable of infinite variation.

See also **Casual Dress; Knitting.**

#### BIBLIOGRAPHY

Black, Sandy. *Knitwear in Fashion*. London: Thames and Hudson, Inc., 2002. A comprehensive and well-illustrated overview of design developments in contemporary fashion knitwear from the 1970s to 2002. Also included: knitting in accessories, interiors, artworks, and performance. Reference section includes technology of knitting and designer biographies.

Macdonald, Anne L. *No Idle Hands. The Social History of American Knitting*. New York: Ballantine Books, 1988. A detailed social history reflecting the role of women in American history from colonial times to the 1980s. The relationship of women in society is expressed through the craft of knitting and traced through changing times and fashions.

Rutt, Richard. *A History of Hand Knitting*. London: B. T. Batsford, Ltd., 1987; Loveland, Colo.: Interweave Press, 2003. An excellent guide to the history and development of hand knitting as a domestic craft, from the sixteenth century. It begins with definitions and techniques, with a unique chronology of the publication of knitting patterns. British knitting is covered comprehensively, with American and Eastern traditions included.

Wright, Mary. *Cornish Guernseys and Knit-Frocks*. London: Ethnographica, 1979. A well-researched account of traditional work wear in Cornwall with a collection of knitting patterns.

*Sandy Black*

**SWEATSHIRT** According to Merriam-Webster's dictionary, the word "sweatshirt" materialized in 1925. It denoted a collarless, long-sleeved, oversize pullover made of thick fleecy cotton. The earliest sweatshirts were gray utilitarian gear that athletes wore while training for traditional sports. Sweatshirts not only provided warmth, but as their name revealed, they also possessed the functional ability to induce and absorb sweat during exercise.

The design of the sweatshirt evolved to include the zipper front "hoodie"—first marketed by Champion Athletic wear for football players to use on the sidelines. Sweatshirts with matching pants ("sweat pants") created an ensemble known as the jog suit, track suit, or sweat-suit, and they became widely popular in the 1970s along with the craze for jogging. Contemporary derivatives ranging from short-sleeved or sleeveless sweatshirts to "sweatskirts" and the development of high-tech materials with better insulation and increased comfort offer proof of the sweatshirt's continuous ability to adapt to the needs of the wearer.

#### Sweatshirt as a Sign

The sweatshirt's potential as a portable advertising tool was discovered in the 1960s when U.S. universities began printing their names on the medium. For students

and parents alike, university names on sweats became the preferred casual attire for exhibiting school pride. The sweatshirt, along with the T-shirt, provided a cheap and effective way of disseminating information on a mass scale. The T-shirt slogan fad of the seventies inevitably translated to sweatshirts. Recognizing the relative simplicity of customization and the power of clever graphics combined with catchphrases, sweatshirts became a vehicle for personal expression for both the designer and the person wearing them.

#### Subcultural Appropriation

The rise of extreme sports in the 1980s, such as surfing and skateboarding, and the simultaneous establishment of hip-hop as a cultural phenomenon, reinjected a whole new level of cool into the sweatshirt. For surfers, the sweatshirt became a practical component of beachwear. The sweatshirt provided the obvious solution to quick warmth upon exiting the ocean, and facilitated drying off by absorbing excess water. As surfing gained a strong following, the sport's popularity was harnessed by various labels, the most successful perhaps being Stüssy and Quiksilver of the 1990s. Favorites of young adults and teens, the brands produced a lucrative globally-marketed clothing line that included, of course, the sweatshirt.

As skateboarders took to the streets translating the vertical movements of surfing to flatland, they too adopted the sweatshirt in part for its functionality—the heavy cotton was an extra layer of cushion between the skin and the concrete pavement. In the early 1980s *Thrasher Magazine* and *Transworld Skateboarding* both began publication and informed skaters of techniques and tricks through short articles and sequences of vivid photographs. The consequence of such a visual resource was the subtext of skate style. Scores of suburban youth, unable to emulate the moves, could now at least imitate the look. This look typically included a T-shirt, baggy cargo shorts/pants, a hooded sweatshirt, and a pair of trainers made for skateboarding. Like their surfing counterparts, skate labels increasingly catered to a wider audience hungry to appropriate the skater look.

Another revolution brewed in the late 1970s, that time on the east coast of the United States. In the South Bronx of New York, hip-hop culture was born out of a rebellion to disco and as an alternative to gang life. Rap, Djing, breakdance, graffiti, and fashion combined to produce an artistic phenomenon that would reach across global boundaries to become a billion-dollar industry.

Early components of hip-hop fashion, otherwise known as "old school," included sweatsuits, Adidas or Puma trainers, Kangol hats, and big, gold jewelry. Colorful sweat ensembles were not only everywhere and cost effective, but they reflected the vibrancy of graffiti murals and proved functional when performing breakdance moves. As groups such as the Sugar Hill Gang, and later Run DMC, began to garner recognition, the old-school

look became representative of hip-hop style. The countless hip-hop fashion labels of the early 2000s continue to promote the legacy of the sweatsuit by maintaining it as a central focus in both their men's wear and women's wear lines.

### Intersection with Fashion

From humble beginnings as athletic wear, the sweatshirt has achieved mass-market domination, re-propelled by the birth of logomania in the 1980s. Designers wishing to cash in on branding, utilized the sweatshirt in part to do so. From Vivienne Westwood's "Anglomania" sailor sweatshirts to Calvin Klein's ubiquitous "CK" example, sweatshirts with designer logos became the affordable version of designer wear for the masses.

The sweatshirt's commercial success is a direct result of its connotations of comfort, sportiness, and practicality. In the early 1980s, designer Norma Kamali sought to create a collection for the working woman that epitomized those aforementioned ideals. Her answer was the well-received Spring–Summer 1980 "Sweatshirt Collection" in which Kamali designed an entire wardrobe from sweatshirt fabric.

Subsequent designers have also utilized sweats—evidenced by sport's influence on both men's and women's Fall 2003 collections. Dolce & Gabbana literally referenced hip-hop on hooded sweatshirts that read "*l'Hip-Hop C'est Chic*" while Bernhard Willhelm's much anticipated menswear debut produced skateboarder inspired skull 'n' crossbone hoodies, Harlequin tracksuiting, and U.S. flag print sweats with confetti overprint. Jean Paul Gaultier's women's wear line put a sporty spin on the classic pinstriped suit with a hooded sweatshirt worn underneath the jacket, and Michael Kors's modern take on the sweatsuit included pairing it with a fur vest. The ultimate marriage, however, between fashion and athletic wear is Y-3, the collaborative by-product of Yohji Yamamoto and Adidas. Here, sportswear is reclassified as high fashion through the introduction of luxury detailing to classic athletic staples like the jog suit.

The sweatshirt's ability to transcend its athletic origins by becoming both an influential component of sportswear and an element of various subcultural dress, testifies to its importance in fashion; furthermore, the fashion system's innate ability to recycle pre-existing motifs guarantees that the sweatshirt will evolve for years to come.

See also **Casual Dress; T-Shirt.**

### BIBLIOGRAPHY

- "Norma Kamali." In *The Fashion Book*. London: Phaidon Press Ltd., 1998.
- "Radical Footing." *Crash* no. 25 (Printemps) 2003.
- Trebay, Guy. "Taking Hip-Hop Seriously. Seriously." *The New York Times* (20 May 2003): 11B.

Vuckovich, Miki. "Denim Wars." *Transworld Skateboarding Magazine* (3 March 2000).

*WWD The Magazine* (Fall 2003).

### Internet Resource

Bennet, Eric. "Hip-Hop." Available from <<http://www.africana.com>>.

Jennifer Park

**SWEATSHOPS** Sweatshops are workplaces run by unscrupulous employers who pay low wages to workers for long hours under unsafe and unhealthy conditions. For example, in a clothing sweatshop in California in the early 2000s, Asian women sewed for ten to twelve hours per day, six or seven days per week, in a dim and unventilated factory loft where the windows were sealed and the emergency doors locked. The workers had no pension or health-care benefits and were paid at a piece rate that fell far below the legal minimum wage. When the company went bankrupt, the owner sold off the inventory, locked out the workers without paying them, moved his machines in the middle of the night to another factory, and reopened under a different name.

The term "sweatshop" is derived from the "sweating system" of production and its use of "sweated labor." At the heart of the sweating system are the contractors. A large company distributes its production to small contractors who profit from the difference between what they charge the company and what they spend on production. The work is low skilled and labor intensive, so the contractors do best when their workers are paid the least. Workers employed under these conditions are said to be doing sweated labor.

Sweatshops are often used in the clothing industry because it is easy to separate higher and lower skilled jobs and contract out the lower skilled ones. Clothing companies can do their own designing, marketing, and cutting, and contract out sewing and finishing work. New contractors can start up easily; all they need is a few sewing machines in a rented apartment or factory loft located in a neighborhood where workers can be recruited.

Sweatshops make the most fashion-oriented clothing—women's and girls'—because production has to be flexible, change quickly, and done in small batches. In less style-sensitive sectors—men's and boys' wear, hosiery, and knit products—there is less change and longer production runs, and clothing can be made competitively in large factories using advanced technology.

Since their earliest days, sweatshops have relied on immigrant labor, usually women, who were desperate for work under any pay and conditions. Sweatshops in New York City, for example, opened in Chinatown, the mostly Jewish Lower East Side, and Hispanic neighborhoods in the boroughs. Sweatshops in Seattle are near neighborhoods of Asian immigrants.





**New York City sweatshop.** A scene from a sweatshop on New York City's Lower East Side, 1908, as photographed by Lewis Hines. The workers here are probably recent Jewish immigrants. Modern-day American sweatshops continue to exist and continue to rely on recent immigrants willing to work long hours for very low pay. © CORBIS. REPRODUCED BY PERMISSION.

The evolution of sweatshops in London and Paris—two early and major centers of the garment industry—followed the pattern in New York City. First, garment manufacturing was localized in a few districts: the *Sen-tier* of Paris and the Hackney, Haringey, Islington, the Tower Hamlets, and Westminster boroughs of London. Second, the sweatshops employed mostly immigrants, at first men but then primarily women, who had few job alternatives. The source of immigrant workers changed over time. During the late nineteenth and twentieth century, most workers in the garment sweatshops of Paris were Germans and Belgians, then Polish and Russian Jews and, into the 2000s, Yugoslavs, Turks, Southeast Asians, Chinese and North African Jews. Eastern European Jews initially worked in London sweatshops, but most of these workers were replaced by Cypriots and Bengali immigrants. Also, sweatshop conditions in the two cities were the result of roughly similar forces; in the nineteenth century, production shifted to lower-grade, ready-made clothing that could be made by less skilled workers; skill requirements further declined with the in-

roduction of the sewing machine and the separation of cutting and less skilled sewing work; frequent style changes, particularly in ready-made women's wear, led to production in small lots and lower entry barriers to new entrepreneurs who sought contracts for sewing; and, as contractors competed among themselves, they tried to lower labor costs by reducing workers' pay, increasing hours, and allowing working conditions to deteriorate.

In developing countries, clothing sweatshops tend to be widely dispersed geographically rather than concentrated in a few districts of major cities, and they often operate alongside sweatshops, some of which are very large, that produce toys, shoes (primarily athletic shoes), carpets, and athletic equipment (particularly baseballs and soccer balls), among other goods. Sweatshops of all types tend to have child labor, forced unpaid overtime, and widespread violations of workers' freedom of association (i.e., the right to unionize). The underlying cause of sweatshops in developing nations—whether in China, Southeast Asia, the Caribbean or India and Bangladesh—is the

intense cost-cutting done by contractors who compete among themselves for orders from larger contractors, major manufacturers, and retailers.

Clothing was not always produced with the sweating system. Throughout much of the nineteenth century, seamstresses made clothing by working long hours at home for low pay. They sewed precut fabric to make inexpensive clothes. Around the 1880s, clothing work shifted to contract shops that opened in the apartments of the recently arrived immigrants or in small, unsafe factories.

The spread of sweatshops was reversed in the United States in the years following a horrific fire in 1911 that destroyed the Triangle Shirtwaist Company, a women's blouse manufacturer near Washington Square in New York City. The company employed five hundred workers in notoriously poor conditions. One hundred and forty-six workers, mostly young Jewish and Italian women, perished in the fire; many jumped out windows to their deaths because the building's emergency exits were locked. The Triangle fire made the public acutely aware of conditions in the clothing industry and led to pressure for closer regulation. The number of sweatshops gradually declined as unions organized and negotiated improved wages and conditions and as government regulations were stiffened (particularly under the 1938 Fair Labor Standards Act, which imposed a minimum wage and required overtime pay for work of more than forty hours per week).

Unionization and government regulation never completely eliminated clothing sweatshops, and many continued on the edges of the industry; small sweatshops were difficult to locate and could easily close and move to avoid union organizers and government inspectors. In the 1960s, sweatshops began to reappear in large numbers among the growing labor force of immigrants, and by the 1980s sweatshops were again "business as usual." In the 1990s, atrocious conditions at a sweatshop once again shocked the public.

In 1995, police raided a clandestine sweatshop in El Monte, California (outside Los Angeles), where seventy-two illegal Thai immigrants were sewing clothing in near slavery in a locked and gated apartment complex. They sewed for up to seventeen hours per day and earned about sixty cents per hour. When they were not working, they slept ten to a room. The El Monte raid showed an unsuspecting public that sweatshop owners continued to prey on vulnerable immigrants and were ignoring the toughened workplace regulations. Under intense public pressure, the federal government worked with unions, industry representatives, and human rights organizations to attack the sweatshop problem. Large companies pledged to learn more about their contractors and avoid sweatshops. Congress proposed legislation that would make clothing manufacturers responsible for the conditions at their contractors. College students formed coalitions with labor unions and human rights organizations to organize consumer boycotts against clothing made in

sweatshops. Despite these efforts, the old sweatshops continued and many new ones were opened.

In the early twenty-first century, about a third of garment manufacturers in the United States operate without licenses, keep no records, pay in cash, and pay no overtime. In New York City, about half of the garment manufacturers could be considered sweatshops because they repeatedly violate pay and workplace regulations. In Los Angeles, the nation's new sweatshop center, around three-quarters of the clothing contractors pay less than the minimum wage and regularly violate health regulations.

The resurgence of sweatshops in the United States is a byproduct of globalization—the lowering of trade barriers throughout the world—and the widespread use of sweatshops to make garments in developing countries. American clothing companies must compete against producers elsewhere that can hire from a nearly endless supply of cheap labor.

In the clothing industry, one sees a classic case of the "race to the bottom" that can come with unrestrained globalization. As trade barriers are reduced, clothing retailers face intensive competitive pressure and, squeezed for profits, they demand cheaper goods from manufacturers. The manufacturers respond by paying less to contractors, and the contractors lower their piece rates and spend less money maintaining working conditions. Quite often, the contractors move abroad because the "race to the bottom" also happens worldwide. Developing countries outbid each other with concessions (for example, wages are set below the legal minimum, child labor and unhealthy work conditions are overlooked) to attract foreign investors.

The fight against sweatshops is never a simple matter; there are mixed motives and unexpected outcomes. For example, unions object to sweatshops because they are genuinely concerned about the welfare of sweated labor, but they also want to protect their own members' jobs from low-wage competition even if this means ending the jobs of the working poor in other countries.

Also, sweatshops can be evaluated from moral and economic perspectives. Morally, it is easy to declare sweatshops unacceptable because they exploit and endanger workers. But from an economic perspective, many now argue that without sweatshops developing countries might not be able to compete with industrialized countries and achieve export growth. Working in a sweatshop may be the only alternative to subsistence farming, casual labor, prostitution, and unemployment. At least most sweatshops in other countries, it is argued, pay their workers above the poverty level and provide jobs for women who are otherwise shut out of manufacturing. And American consumers have greater purchasing power and a higher standard of living because of the availability of inexpensive imports.

The intense low-cost competition spurred by the opening of world markets is creating a resurgence of sweatshops in the United States. The response has been a large and energetic anti-sweatshop movement aimed at greater unionization, better government regulation, and consumer boycotts against goods produced by sweated labor. But despite the historical rise and fall and rise again of sweatshops in the clothing industry, their fundamental cause remains the same. The sweating system continues because contractors can profit by offering low wages and harsh conditions to workers in the United States and abroad who have no alternatives.

See also **Globalization**.

#### BIBLIOGRAPHY

- Piore, Michael. "The Economics of the Sweatshop." In *No Sweat: Fashion, Free Trade, and the Rights of Garment Workers*. Edited by Andrew Ross. New York: Verso, 1997, pp. 135–142. A brief, well-written review of the economic factors behind the operation of sweatshops in the garment industry.
- Rath, Jan, ed. *Unraveling the Rag Trade: Immigrant Entrepreneurship in Seven World Cities*. New York: Berg, 2002. A collection of articles about immigrant workers and entrepreneurs in the emerging garment industries of seven major production centers including New York, Paris, and London.
- Rosen, Ellen Israel. *Making Sweatshops: The Globalization of the U.S. Apparel Industry*. Berkeley: University of California Press, 2002. A comprehensive study of the impact of globalization on sweatshops in the American garment industry, with detailed analyses of their historical development and present condition.
- Stein, Leon, ed. *Out of the Sweatshop: The Struggle for Industrial Democracy*. New York: Quadrangle, 1977. A collection of classic essays, news stories, and workers' firsthand accounts of sweatshops with particularly strong sections on immigrants, early sweatshops, and union organizing and strikes.
- Von Drehle, David. *Triangle: The Fire that Changed America*. New York: Atlantic Monthly Press, 2003. A vivid and informative account of the 1911 Triangle fire—the deadliest workplace fire in American history and an early turning point in the evolution of sweatshops and the government regulation of work.

Gary Chaison

**SWIMWEAR** Clothing for swimming, bathing, and seaside wear has been an important and influential area of fashionable dress since the late nineteenth century. The evolution of swimming and bathing costumes has been closely associated with trends in mainstream fashion and advancements in textile technology, but has also reflected broader societal attitudes about personal hygiene, body exposure, and modesty, and whether or not it was appropriate for women to participate in active sports.

#### Bathing Costumes

Swimming and bathing were common activities in the ancient world, and the Romans built public baths in even the most remote parts of their empire. After declining during the Middle Ages, bathing was revived in the seventeenth century, when it became popular as a medicinal treatment. At spas such as Bath and Baden, where bathers sought out the warm mineral waters for their therapeutic effects, linen bathing garments—knee-length drawers and waistcoats for men, and long-sleeved linen smocks or chemises for women—were in use by the late seventeenth century. These garments were worn for modesty rather than appearance, and could be hired from the baths by those who did not wish to purchase their own.

In the eighteenth century, medical authorities began to prescribe salt-water bathing, and seaside towns, along with large floating baths in most major cities, began to cater to large numbers of health-conscious visitors. Bathing usually consisted of a quick dip, often in the early morning, and was considered more a duty than a pleasure. Until the mid-nineteenth century, male and female bathers were almost always segregated from each other, either through the provision of separate bathhouses or stretches of beach, or by using the same area at different assigned times. Modesty was also preserved by the use of "bathing machines"—small buildings mounted on wheels, in which the bather would change from street clothes into a bathing costume while a horse and driver pulled the machine into the sea. The steps by which the bather would descend into the water were often covered with an awning to ensure that he or she would not be seen until mostly underwater. Thus protected from the eyes of the opposite sex, men generally bathed nude, or in simple trunks with a drawstring waist; women's bathing gowns were cut much like the chemise (undergarment) of the period, but were often made of stiffer material so as not to cling to the figure, and sometimes incorporated weights in the hem to keep the gown from floating. The only purpose of bathing garments at this time was to keep the bather warm and sufficiently covered up, and little thought was given to their appearance.

In the early nineteenth century, bathing began to be considered a recreational as well as beneficial activity, and seaside holidays grew in popularity. Each locality had its own standards for appropriate attire, and the costumes worn varied widely from place to place. In general, however, as women began to be more active in the water, rather than simply immersing themselves, their bathing dresses became slightly shorter, and were gathered or fitted around the waist. At the same time, ankle-length drawers or pantaloons, similar to the drawers worn as underwear by ladies in the 1840s, began to be worn underneath.

From the mid-century on, mixed bathing became more acceptable, and as stationary beach huts began to replace bathing machines, bathing costumes were more visible, and attention began to be paid to making them





## BATHING BEAUTIES

Beautiful aquatic women have been important fantasy figures since ancient times, when sirens, mermaids, and water nymphs led heroes of mythology astray. The modern-day bathing beauty, however, did not appear until the late nineteenth century, when bathing dresses were first seen in public. As these were the most revealing costumes allowed for women at the time, images of pretty bathing girls, both in wholesome advertisements and on naughty postcards, soon proliferated. Around 1914, the comedies of silent film producer Mack Sennett began to feature a bevy of young women in exaggerated and revealing bathing dress, whom he called his Bathing Beauties. Their popularity inspired beach resorts such as Venice Beach, California, and Galveston, Texas, to stage annual bathing girl parades and beauty contests; the Miss America pageant started as one such bathing girl contest, held in Atlantic City, New Jersey in 1920 to encourage late-season tourism. Over the years this and other beauty pageants, with their parades of women in bathing suits and high heels featured in newsreels and television broadcasts, have been instrumental in associating swimwear with feminine beauty in the popular imagination. (This connection was not lost on Catalina Swimwear, a major pageant sponsor, which started the Miss USA and Miss Universe pageants after the 1951 Miss America refused to pose in a swimsuit during her reign.)

The Hollywood bathing beauty came of age in the 1930s, when photographs of stars and starlets posing in fashionable swimwear began appearing in large num-

bers. These images had an impact on fashions, as women sought to emulate the look of their favorite stars, and achieved iconic status during World War II, when pin-ups of Betty Grable and Rita Hayworth came to symbolize “what we’re fighting for” to many American servicemen. Another, more active kind of bathing beauty was showcased in the aquatic ballets of Billy Rose’s Aquacades at the 1939–1940 World’s Fair, in the water-skiing spectaculars at Cypress Gardens in Florida, and, most memorably, in the lavish MGM films featuring Esther Williams, the first of which was the 1944 *Bathing Beauty*. Miss Williams, a 1939 national swimming champion, was a top box-office draw through the mid-1950s, and her film costumes, together with her ability to look glamorous before, during, and after swimming, did much to inspire the desired poolside look of the era.

Since its debut in 1964, *Sports Illustrated’s* annual swimsuit issue has probably been the most relevant modern incarnation of the bathing beauty tradition, and has come to symbolize its contradictions. Widely credited with popularizing the active, healthy California look in the 1960s, and thus encouraging women to be more athletic, the swimsuit issue has also been criticized for displaying women as sex objects for the enjoyment of a predominantly male audience. Seen as empowering, exploitative, or both, the bathing beauties seen in *Sports Illustrated* continue to influence swimwear fashion, and to act as a kind of barometer for changing cultural attitudes and standards of beauty.

more attractive. Bathing styles began to be covered by popular magazines, which both standardized bathing costumes and brought them into the realm of fashion, with new styles introduced each season. Women’s costumes began to follow the silhouette of street fashions more closely in this period, but also developed their own fashion vocabulary; they were usually made of wool flannel or serge, in dark colors (which were less revealing of the figure when wet), and enlivened by jaunty details such as sailor collars and braid trim in contrasting colors. Bathing costumes also now required many fashionable accessories. Hats, rubberized and oilcloth caps, and a variety of turban-like head-wraps kept hair neat and protected from salt water. Full-length dark stockings kept the legs modestly covered, and flat-soled bathing shoes, often with ribbon ties crossing up the leg, protected the feet and set off the ankles. As wool bathing dresses became quite heavy when wet, and clung to the figure in a way that

was considered unattractive and immodest, bathing capes and mantles were also considered necessary for the walk from the water to the changing room.

Later in the century, bathing dresses (the term “bathing suit” also came into use at this time) became more practical, with both skirt and pantaloons gradually shortened, necklines lowered, and sleeves shortened or even eliminated. In the United States, where it took longer for these styles to catch on, the one-piece (or “princess-style”) costume became a popular alternative in the 1890s; this consisted of an attached blouse and knee-length drawers, with a separate knee-length or shorter skirt that could be removed for swimming. Even so, most bathing costumes were essentially variations of street fashions, intended largely for promenading by the sea and wading or frolicking in the surf; many required the wearing of a corset underneath, and were made of materials that would be ruined if they ever got wet. In the early



**Models in jersey swimwear.** As seen in this 1929 photo, swimwear in the 1920s was styled similarly for men and women. It had only recently become acceptable for women's swimwear to show bare legs. © CONDÉ NAST ARCHIVE/CORBIS. REPRODUCED BY PERMISSION.

twentieth century, the term “bathing dress” came to mean this kind of fashionable, skirted costume, as opposed to the utilitarian “swimming suit.” Chemise-style silk bathing dresses with bloomers or tights continued to be worn by some women into the 1920s, but by the 1930s they were obsolete, and the terms “bathing suit” and “swimsuit” had become interchangeable.

### Swimming Suits

Until the mid-nineteenth century, swimming was an activity almost entirely limited to men. While men and women were segregated at baths and beaches, men were free to practice swimming unencumbered by clothes. As mixed bathing became more popular, however, they were forced to find a suitable costume, and by the 1850s men generally wore one-piece knit suits very similar to contemporary one-piece underwear (called union suits), but usually with short sleeves and legs cut off at the knees. Later in the century, there was also a two-piece version available, consisting of a short-sleeved or sleeve-

less tunic over knee-length drawers. To avoid any hint of impropriety caused by appearing in garments so similar to underwear, men's bathing suits were usually dark in color, sometimes with contrasting bands at the edges; striped suits were also popular, especially in France. This practical knit costume remained basically unchanged until the 1930s.

Women who wished to swim, however, found it much more difficult to find a suitable costume. Beginning in the 1860s, women were encouraged to take up swimming for exercise, and by the 1870s many women were learning to swim at pools and bathhouses, which had separate times designated for male and female bathers. In these sex-segregated situations, and for swimming competitions and demonstrations, female swimmers adopted simple “princess-style” one-piece suits, knitted garments similar to men's suits, or suits with long tights similar to those worn by circus performers. However, these garments were still not acceptable in mixed company, or for public wear out of the water, until the early twentieth century. The Australian swimmer Annette Kellerman became famous early in the century for her long-distance swimming feats and exhibitions of fancy diving, for which she wore sleeveless, form-fitting one-piece suits of black wool knit, sometimes with full-length stockings attached. She was an outspoken advocate for practical swimwear for women, and when she was arrested for indecent exposure for wearing a one-piece suit to a public beach in Boston in 1907, the resulting trial and publicity helped to change public attitudes on the subject. In 1912, the Olympic Games in Stockholm were the first to include women's swimming events, and by the beginning of World War I, one-piece knit suits had gained wide acceptance. In many places, however, local authorities passed strict bathing suit regulations, and the battle over the alleged indecency of abbreviated suits, particularly when worn without stockings, continued in many places into the 1920s.

### The Modern Swimsuit

After World War I, several factors combined to produce a radical change in swimwear. Women had achieved new levels of independence during the war, and fashions began to allow them more freedom of movement. Interest in active sports of all kinds increased during the 1920s, and sportswear achieved new importance in fashion. Swimming also gained in popularity due to an increase in the number of municipal swimming pools, and the publicity given to such celebrities as Gertrude Ederle, who in 1926 became the first woman to swim the English Channel. Form-fitting knitted wool tank suits, almost identical to those worn by men, were promoted as active swimwear for the modern woman, and soon became the dominant style. At the same time, beach resorts on the Riviera or at Palm Beach became an important part of the fashionable calendar, and beach fashions assumed new significance in society wardrobes. Paris couturiers such

as Jean Patou, Jeanne Lanvin, and Elsa Schiaparelli used crisply detailed knit suits—both two-piece suits of tunic and trunks and one-piece suits (known as maillots)—as a canvas for geometric designs in bold, contrasting colors. Spending long leisurely days at the beach also required an extensive on-shore wardrobe, including sunsuits and sunbathing dresses, beach coats and capes, bathing shoes and sandals, close-fitting hats for swimming and wide-brimmed hats for shade, colorful beach umbrellas, beach pajamas (very popular in the late 1920s) and, to hold it all, large canvas beach bags.

By the early 1930s, the growing popularity of sunbathing inspired suits with very low-cut “evening-gown” backs, suits with removable straps for sunning, and suits with large cutouts at the sides and back. The one-piece maillot, with or without a vestigial skirt or skirt front (called a “modesty panel”), was still the most common style, but two-piece suits, consisting of a high-waisted skirt or trunks and a brassiere or halter top, were introduced early in the decade. These sometimes coordinated with matching separates to convert into sundresses or playsuits, which succeeded beach pajamas as the most fashionable form of on-shore beachwear. So-called dress-maker suits were another popular style; these were skirted suits with attached trunks, cut like dresses and usually made of printed or textured woven fabrics (sometimes with an elastic liner).

### The Swimwear Industry

In the years following World War I, American manufacturers of ready-made swimwear, most of them based on the West Coast, played a major role in setting fashion trends, and in creating a mass market for fashionable swimwear. The first Jantzen swimming suits, introduced in the late 1910s, were knit in a double-sided rib stitch, which added elasticity and made knitted suits much more practical. The company’s innovative advertising campaigns in the 1920s, often featuring Olympic champion swimmers such as Johnny Weissmuller, helped to popularize swimming as well as Jantzen bathing suits, and by 1930 Jantzen was the largest swimwear manufacturer in the world. Catalina and Cole of California, which became major competitors to Jantzen in the late 1920s, emphasized appearance and styling in their suits and advertisements; Catalina became associated with the Miss America pageant, and Cole with Hollywood glamour. Competition between these manufacturers, joined by B.V.D. in 1929, drove changes in swimwear styles and technology through much of the twentieth century.

When feminine curves returned to fashion around 1930, manufacturers began to find ways of shaping the body within the suit, using darts, seaming, and strategically placed elastic to uplift and emphasize the bust. The most important innovation, however, was Lastex, an elastic yarn consisting of an extruded rubber core covered in cotton, rayon, silk, acetate, or wool, which was introduced



**Bikini bras in production.** Treated fabric, having been stretched over a plastic mold, is about to be baked in order to set its shape and create bikini brassieres. These bras were manufactured in 1949, but it was not until the 1960s that bikinis caught on in the United States. © HULTON-DEUTSCH COLLECTION/CORBIS. REPRODUCED BY PERMISSION.

in 1931 and soon revolutionized the industry. It could be used in both knitted and woven fabrics, gave improved fit and figure control, and allowed designers to add supporting layers, such as brassieres and tummy-control panels, without adding bulk to the silhouette. Lastex-based fabrics, some also incorporating new synthetic yarns, were soon available in a variety of textures and surface treatments, including stretch satins, velvets, shirred cottons, and novelty knits. All-rubber suits, made of embossed rubber sheeting, were introduced in 1932, and were an inexpensive option throughout the decade, though they were easily torn, and sometimes peeled away from the body in pounding surf. Rubber found more practical application in bathing caps, which now fit close to the head to keep the hair dry, and in bathing shoes, many of which were molded rubber facsimiles of street footwear.

The 1930s were also when swimwear manufacturers first turned to Hollywood for style ideas and promotional tie-ins. Jantzen, Catalina, and B.V.D. began to use Hollywood stars in their advertising campaigns, and formed alliances with movie studios and studio designers, lending mass-produced suits an air of Hollywood glamour. Bathing suits worn by stars in films and publicity photos became a major source of swimwear fashion. For example, the strapless sarong-like costumes worn by Dorothy





**Esther Williams poses in a bathing suit in 1945.** Esther Williams achieved stardom and box office success with a number of “swimming movies” in the 1940s and 1950s, musicals that featured elaborate aquatic dances and that showcased her swimming talents. © BETTMANN/CORBIS. REPRODUCED BY PERMISSION.

Lamour, first seen in the 1936 film *Jungle Princess*, immediately inspired manufacturers to include sarong suits in their lines, and helped set a fashion for tropical prints in swimwear.

### New Styles for Men

While the detailing of men’s suits had been somewhat updated by the late 1920s, and their construction and performance had been improved, decency regulations in many places still required men to wear suits that covered the chest up to the level of the armpits. As sunbathing became more popular, manufacturers tried to work around these regulations, producing suits with side and back cutouts to permit more sun exposure. Pressure to reduce the amount of fabric in suits also came from competitive swimmers, who quickly adopted the silk knit racer-back suits (with low-cut sides and a single back strap to reduce drag) introduced by the Australian company Speedo in 1928. By the early 1930s, public opinion on the decency of the male chest had begun to shift, and American manufacturers developed convertible suits, with tops that could be zipped off where shirtless bathing was allowed. Swimming trunks, although sold with matching shirts in

more conservative markets, began selling well in 1934, and by 1937 had almost completely supplanted the one-piece tank suit. The more abbreviated and close-fitting styles of Lastex with built-in athletic supporters were given outerwear details, such as belts, pockets, and fly fronts, to distinguish them from underwear. Around 1940, the looser boxer-short style, usually boldly patterned, became another popular alternative, with matching short-sleeved sports shirts worn as cover-ups.

### Postwar Styles

By the early 1940s, women could choose from a wide variety of styles and fabrics, and were encouraged to have a wardrobe of suits appropriate for different activities and occasions. The bust was increasingly emphasized in both one- and two-piece suits, through strategically placed cutouts, ruffles, and bra sections ruched or tied at the center to form a sweetheart neckline. Dressmaker suits made of woven fabrics were popular, in part because Lastex was in short supply during World War II; these included a new category of dressier suits, meant largely for lounging by the pool, with details borrowed from evening wear and an emphasis on firm figure control. Figure control became even more important after the war, as swimwear adopted the dramatic corseted silhouette made fashionable by Christian Dior’s 1947 “New Look” collection. Lastex was once more available, and new synthetic fibers such as nylon were quickly adopted for use in swimwear. Suits began to be constructed like foundation garments, with boning, underwires, interfacing, and padding producing the desired high, pointed breasts, tiny waist, and jiggle-free figure.

Though the first bikini was introduced in 1946, the reaction in America was to move toward more covered-up suits, exemplified by the ladylike designs of Rose Marie Reid. In the 1950s, amid growing prosperity and increasing amounts of leisure time, and as more Americans had access to resort vacations and backyard pools, swimwear became more than ever a vehicle for display and fantasy. Swimwear manufacturers found design inspiration in exotic locales such as Mexico and Polynesia, and tropical print and batik ensembles, worn with printed cotton cover-ups and rustic accessories of straw, wood, and raffia, were popular throughout the decade. Exotic animals, especially felines, were another popular theme, as exemplified by the seductive leopard-spotted suits of Cole of California’s “Female Animal” collection. Some glamorous poolside ensembles were made of waterproof taffeta and lamé, cut like strapless evening gowns, and decorated with beading and sequins to evoke ancient Egypt or the Arabian Nights. A wide variety of sunsuits, terry-cloth robes, footwear, bathing caps, and sunglasses, along with waterproof makeup, allowed women to maintain a polished appearance, both in and out of the water.

While most 1950s suits were designed to mold the figure to an artificial ideal, a few American designers, in-

cluding Claire McCardell, Carolyn Schnurer, and Tina Leser, took a different approach. Beginning in the 1940s, they designed unpretentious swimwear and playsuits, usually of wool jersey or printed cotton, which emphasized practicality and freedom of movement over static display. McCardell's ingeniously draped and wrapped jersey suits were praised by the fashion media, but her body-conscious approach had little impact on mainstream styles until the mid-1950s, when swimwear in a similar spirit by designer Rudi Gernreich began to receive attention. Gernreich's sleek wool knit suits, inspired by dancewear, offered a stylish alternative to structured suits, and embodied the casual spirit of California, the source of many lifestyle trends in the late 1950s.

### The 1960s to the Present

By the early 1960s, changing attitudes toward body exposure, together with the growing influence of the youth market, brought a new mood to swimwear. The new ideal of a youthful, tanned, and healthy look, with girls in bikinis and boys in cut-off blue jeans or baggy trunks (known as "jams"), was disseminated by beach party movies and the surf music craze. As the decade progressed, swimwear became briefer and more daring, with tiny bikinis, cutouts, mesh and transparent panels, and Rudi Gernreich's famous topless suit. Designs were drawn from an eclectic variety of sources, including pop art, scuba-diving gear, science fiction, and tribal costumes from around the world. The most important swimwear development, however, was the availability of spandex, a lightweight synthetic polyurethane fiber much stronger and more elastic than rubber, which was introduced for use in foundation garments in 1958. Spandex expanded the range of novelty fabrics available to designers, and that meant suits could now be made to fit like a second skin without heavy linings and supporting layers.

In the 1970s and 1980s, a fit, sculpted, and toned body became the new ideal. Rather than shaping the body, fashionable swimwear and beachwear was now designed to frame and reveal it, and difficult-to-tone areas such as the buttocks and upper thighs became the new erogenous zones. Athletic styles, such as racer-back tank suits and the Speedo briefs worn by Mark Spitz at the 1972 Olympics, were a major influence. One-piece suits returned to fashion, though many of them were essentially complex networks of crossed and wrapped straps joining small areas of fabric, and offered little more coverage than contemporary thongs and string bikinis. Stretch fabrics could be made lighter than ever, and bright, solid colors and metallic finishes were used for sleek maillots with thin spaghetti straps, which with the addition of a wrap skirt could double as disco wear.

Since the 1980s, despite warnings about the dangers of ultraviolet radiation, swimwear and beachwear have remained an important part of most wardrobes. Swimwear has been in what might be called its postmodern phase,

with a wide variety of styles and influences operating simultaneously. Retro styles first appeared in the early 1980s, when designers such as Norma Kamali revived the glamorous Shirred and skirted styles of the 1940s, and designs recalling every decade of the twentieth century have since appeared. Other recurring themes have been underwear-as-outerwear styles, with visible boning and underwires; minimalism; and streamlined athletic styles, emphasizing high-tech fabrics and finishes. Men have also been able to choose from a range of retro looks and amounts of coverage, from skimpy bikini briefs to baggy knee-length surfer styles; extremely baggy shorts with low-rise waists are a popular look in the early 2000s. Two late-1990s innovations were the tankini, a two-piece suit with the coverage and figure control of a one-piece, and the concept of mix-and-match swim separates, with a variety of bra styles, trunks, and skirted bottoms recalling the versatile playsuits of the 1930s and 1940s, and offering consumers unprecedented freedom of choice.

See also **Bikini; Gernreich, Rudi; Kamali, Norma; McCardell, Claire; Patou, Jean.**

### BIBLIOGRAPHY

- Cunningham, Patricia. "Swimwear in the Thirties: The B.V.D. Company in a Decade of Innovation." *Dress* 12 (1986): 11–27.
- Johns, Maxine James, and Jane Farrell-Beck. "Cut Out the Sleeves: Nineteenth-Century U.S. Women Swimmers and Their Attire." *Dress* 28 (2001): 53–63.
- Kidwell, Claudia. *Women's Bathing and Swimming Costume in the United States*. Washington, D.C.: Smithsonian Institution Press, 1968.
- Lansdell, Avril. *Seaside Fashions 1860–1939*. Princes Risborough, U.K.: Shire Publications, 1990.
- Lenček, Lena, and Gideon Bosker. *Making Waves: Swimsuits and the Undressing of America*. San Francisco: Chronicle Books, 1989.
- Martin, Richard, and Harold Koda. *Splash!: A History of Swimwear*. New York: Rizzoli International, 1990.
- Probert, Christina. *Swimwear in Vogue*. New York: Abbeville Press, 1981.

### Internet Resource

- Miss America Organization. "Miss America History." Available from <<http://www.missamerica.org/meet/history/default.asp>>.

Susan Ward

**SY, OUMOU** Oumou Sy (1952–) was born in Podor, Senegal. An autodidact, she is an internationally renowned and unique creative force who works at the intersection of art, spectacle, and social space. While her imaginative talent has been honed on costume design and manufacture since the early 1980s, her contribution is marked by

her collaborations with other African artists in multiple media, including cinema, theater, music, and dance. This theatrical predilection provides a signature to her designs of costumes, haute couture, jewelry, and accessories, while her recent prêt-à-porter lines rely more on local conventions of dress.

### Cultural Imperatives

Sy's work and life raise the arts of cloth, clothing, and body adornment to parity with the fine arts, literature, and cinema, in all of which the Senegalese excel. In the context of Dakar's Francophilic cultural elite, Sy openly and fiercely declares that she chooses not to write or read French. She often reminds listeners that she was raised in a conservative Toucouleur Muslim family in St. Louis, an old trading and colonial city of coastal Senegal. Yet, her articulate spoken voice in French lends an unusual intelligence and authority to her presence and designs. When she puts on her colonial officer's hat and says she is here to conquer, she means it. Her spectacular fashion shows are therefore not only visual and sensory feasts but also a platform for the articulation of an African pride that mines the past and present to produce a future that is in constant dialogue with origins. In effect, she places the cherished, rich Senegambian heritage of artisanship and body adornment into dialogue with the transnational terrain of the contemporary arts. Centuries of transregional trade with Europe and the Middle East and its former status as a French colonial capital have bred a fertile terrain for African and diasporic cultural production in Dakar. Sy is a bold, creative talent and figure for the arts in Dakar who innovates, even more than her creative cohort of African designers, with the materials, forms, and images of both African heritage and modernity. In 1996 Sy and her husband, Michel Mavros, a French filmmaker, founded *Metissacana*, a Web site, cyber café, and cultural center in downtown Dakar, Senegal. *Metissacana* is a Bambara French creole word meaning "the mixing of races and cultures (*metisage*) has arrived." This center spearheaded an emergent infrastructure for African fashion until its closure in 2002.

### Launch of a Career

The complex place of gender in Sy's personal and creative narratives involves self-affirmation, transgression, and play. In her own life, Sy speaks of her mother's loyalty when she used profits from weaving commissions to buy her talented teenage daughter a sewing machine. Refusing her family's choice of suitors, Sy rebelled and married a mixed-race, Roman Catholic, Cape Verdean. The marriage ended in divorce, however, and at that point she moved around the country, finally settling in the old African district of colonial Dakar, the Medina, with her children. With the help of Dakar artists like Kalidou Sy, director of the School of Fine Arts, she launched her career in Dakar. Sy conceals her struggle in her playful figures of womanhood, especially perfume woman, cy-

berwoman, and calabash woman. The costumes worn by these characters present a subversive, mocking femininity in which icons used to polarize Africa and the West as primitive and civilized societies, respectively, are employed as decoration. She said in an interview for France's TV5, "Europeans think Africa is just too much, excess, and that's what calabash woman is about." She also commented in an interview at the Prince Claus Fund award ceremony, "Women of the future will be complete, outfit, accessories, everything" by looking to origins and reconstructing themselves aesthetically.

Since 1989 Sy has produced costumes, sets, hairstyles, and makeup for seventeen films, thirteen staged shows, and for musicians such as Baaba Maal and Yousou N'dour. This has brought her prizes from major festival contests and a much broader audience than fashion shows would allow. In the film *Hyenas* (1992), splendor adorns not royalty but the slaves of an old woman who was cast out from her home village as a young, pregnant girl and comes back to exact revenge. Obsessed with raw power, she uses her slaves to exhibit her beauty, power, and wealth. While Sy's designs for this woman and her entourage create spectacles in some scenes, their neutral tones fuse with the desert scenery to create visual effects of severity.

### Design Characteristics

Sy constructs silhouettes of power expressed through volume and density. Refined artisanship provides the foundation of the costume's primary elements of cloth, and careful adornment of both the cloth and the body complete the effect. Inspired by the aristocratic traditions of the Wolof and Toucouleur—the major ethnic groups in Senegal—as well as the Islamic grand boubou, a six meter flowing, embroidered robe (called *mbubb* in Wolof), her garment forms are characterized by simple stitching of long swathes of cloth that are layered and wrapped. Like many other African designers, she innovates cloth traditions through production technology or the use of "African" cloth (such as cotton prints, woven strips, hand-dyed fabric) in Western styles. She designs tie-dye motifs and weaving for the broadloom, which she uses to weave cloth strips from two- to four-feet long, thereby producing large strips of cloth and reducing the number of seams required to stitch a garment; she also employs expert artisans who often experiment with mixtures of thread or dyes. Sy makes frequent use of embroidery in her costumes and fashion lines. Moreover, in these lines, she gives these traditional garments a Westernized form with belts, sashes, or tailored waistlines that lend contours to the body. African heritage is also the basis for her ornate accessories, jewelry, hairstyles, and makeup.

More than a collection based upon a design concept, Sy's costumes present tableaux of historical epochs. For example, the *Rois et Reines* series (Kings and Queens), dates from the mid-1990s and is inspired by the few his-



torical images available of precolonial Wolof and Toucouleur royal finery. Heavy woven wrappers made of stitched strips of cloth are worn with simple tunic tops of the same cloth. Stoles, heavy amber jewelry, hair jewelry, woolen wigs, and makeup complete the adornment. Dark hues define the natural cloth dyes and the black facial makeup on tattooed lips and lined eyes. Silver and gold decorations on arms and in woolen wigs lend a luxurious feeling to the wearer.

Like the most innovative of designers, Sy's usage of primary materials is distinctive, for she does not limit herself to textiles. Her work is deeply modern, ironic, and humorous and uses an excess of materials from all sources. These media range from the urban garbage of perfume bottles to compact discs, calabashes, baskets, and feathers. The cyberwoman wears a taffeta pastel ball gown with CDs adorning the gown's neck and front surface as if embroidering a boubou. Perfume woman is adorned in a slinky, purple silk, wrap skirt and halter top with small perfume bottles—the cheap, sweet kind from Mecca—sewn on as if they were beadwork. Her face is framed with colored glass wands. Calabash woman wears a tight evening dress with a slit right up her leg and gourds springing from her headdress. These designs have often been photographed in the city streets of Dakar amid garbage, wrecked cars, and minivans. These icons of Africa and the West become signposts in the urban landscape for the tragicomedy of modernity, invoking an historical epoch through a series of garments.

### Awards and Legacy

Sy has won prestigious prizes such as the Prince Claus Fund's 1998 prize, given to African fashion and shared with Alphadi of Niger and Adzedou of Ghana; the same fund gave her an honorary mention as an urban hero for her work with Metissacana (2000). She has also garnered honors for her representation of African fashion at the World Expo of Hanover (2000) and has won the prize of the festival of Wurzburg, Germany (2002); a special prize of the city of Rome (2003); and woman of the millennium (Guinea, 2003). Additionally, her costumes have won awards at the Pan-African Film Festival (1993) and those of Milan (1993) and Johannesburg (1995). She was commissioned by the French government to design costumes for the Dakar celebration of the French revolution's bicentennial (1989). She won the Radio France International Net Africa Prize for founding Metissacana, the first cybercafe in West Africa (2001). Her work has also been exhibited at several museums in Germany, and her couture is sold in boutiques in Paris and New York as well as in Dakar.

As an institution builder in culture and the arts, Sy has founded schools of modeling (Macsy) and couture (Leydi) that have produced prizewinning students. Since 1997 she has organized annual international African fashion weeks (SIMOD) that bring together African designers and models for display and networking in a



### FROM *LA VIE A DE LONGUES JAMBES*

La beauté, c'est une chose à l'intérieur. La beauté du corps, ce n'est pas très important. Tous les corps sont beaux. Mais la vraie beauté, la vraie valeur de la beauté, c'est à l'intérieur qu'il faut la chercher. C'est là qu'elle a sa vraie valeur, et c'est là qu'elle est rare. Voilà la réponse à ta question. La beauté à l'intérieur, c'est ce qui devrait être notre but à tous.

[Beauty, it is an interior matter. Bodily beauty is not very important. All bodies are beautiful. But true beauty, the true value of beauty, it's in the interior that one must search. It is there that there is true value and it's there that is rare. That's the answer to your question. Interior beauty should be the goal of us all.]

Oumou Sy and Jean-Michel Bruyere, *La Vie a de Longues Jambes* [Life has long legs], 1995; translated by Hudita Mustafa.

collaborative, noncompetitive environment. In the 1990s she organized the Carnival of Dakar, a revival of the traditional Fanal parade from her hometown, St. Louis. The event parades models in the costumes and fashions described above through the streets of Dakar's popular neighborhoods. The Metissacana Web site provided links to and information about cultural events and designers as well as an online store for distributing Sy's own clothing and jewelry line. More than this, the site was intended to spearhead national Internet culture in urban and rural Senegal, but it was closed in 2002 due to financial constraints and privatization of national telecommunications systems.

Sy's work of translation across historical epochs, social strata, and cultures make her art, spectacle, and social spaces so appealing to so many. In sum, the broad scope of Sy's creative and institutional interventions in Senegalese culture demonstrates not only her individual genius but also the way that cloth and fashion are embedded in so many aspects of Senegalese society and culture from elite consumption to popular festivity.

See also **Colonialism and Imperialism; Ethnic Dress; Ethnic Style in Fashion; Textiles, African; Tie-Dyeing.**

### BIBLIOGRAPHY

There is very little written on Oumou Sy. An Internet search on her name would yield press reports, images, and some interviews from fashion shows in Europe. Two Internet sites with documentation are <www.metissacana.sn> and <www.perso.wanadoo.fr/afro.art.cybergallery/fashion/prince-claus-fond>. On the Senegalese fashion context generally, see the following sources.

SY, OUMOU

Mustafa, Hudita. "The African Place: Oumou Sy, Dakar, Senegal." *Archis: A Journal of Architecture, City, Visual Culture* 12 (2000): 48–51.

———. "Ruins and Spectacles: Fashion and City Life in Contemporary Senegal." *Nka: A Journal of Contemporary African Art* 15 (2002): 47–53.

Plas, Els van der, and Marlous Willemsen, eds. *The Art of African Fashion*. The Hague, Netherlands: Prince Claus Fund for

Culture and Development and Africa World Press, 1998. General resource with essays and color images.

*Revue Noire* 27 (March 1998). Special issue on African fashion that reviews important contemporary African designers, including Sy.

*Hudita Mustafa*



**TAILORED SUIT** The tailored suit is a garment for women consisting of a jacket and a skirt, most often made of the same fabric. This name for the garment appeared in the fashion press around 1885. It owes its name to the particular manner in which it is made. Produced for women by tailors who specialized in the making of men's garments, it came to prominence at a time when the norm was to differentiate men's and women's clothing by means of very specific techniques, forms, fabrics, colors, and designs. The fashion spread almost everywhere in Europe and the United States thanks to the fame of the English company Redfern, whose style was made popular by famous women, notably Queen Victoria. The Parisian branch of the company, established on the rue de Rivoli at the end of the nineteenth century, contributed to this success.

The emergence of this practical and functional garment within a previously uncomfortable and ostentatious female wardrobe shows the transformation in attitudes by Western society in the late nineteenth century. Women in search of new garments better adapted to ways of life connected to the industrial revolution and its resultant social transformations found the ideal garment in the tailored suit. Since the suit fit the requirements of such new forms of behavior as sport and travel, as well as the progress of hygiene, upper-class women played a role in its adoption by the general population. The affirmation of the suit by the urban middle class—primarily its emancipated women who took up professional careers—was the principal force behind its acceptance.

The tailored suit had a veritable genealogy, however, and was not created *ex nihilo*. In particular, women's riding costumes became fashionable in aristocratic circles in the late seventeenth century. The costume of English Amazons, made up of a fitted coat and a short skirt, in favor in the late eighteenth century, was already close in style to what would become the tailored suit. Although dresses made up the bulk of women's wardrobes, jackets and skirts, often matched, had been worn since the late sixteenth century by the urban working class.

This fashion spread in Enlightenment circles concerned with egalitarianism in clothing. Many details borrowed from men's clothing—buttons, pockets, colors, fabrics, and sometimes even pants—went along with the

jackets and asserted equality between the sexes, suggesting the future of the tailored suit. Throughout the nineteenth century, jackets matched with skirts or pants were worn as a kind of manifesto for the emancipation of women, and the costume thereby acquired a nefarious reputation. A few major female representatives of non-conformism and radicalism, such as George Sand, Flora Tristan, Amelia Bloomer, and Emmeline Pankhurst, gave it an almost political character.

Around 1850, the walking suit appealed to an urban society fascinated by nature and open space. This outfit made up of a jacket and a skirt that did not cover the ankles, in the age of crinolines and corsets, was the last avatar before the emergence and the success of the tailored suit.

The first suits that can truly be given the name were marked by the English influence that predominated in the late nineteenth century. British women, who launched the craze for sports, travel, and tourism, were the first to adopt them. London society, where feminists were influential, adopted the style, which incidentally corresponded to the sobriety admired by countries with a Protestant culture. These first tailored suits had jackets whose cut and details were borrowed from men's clothing, but their forms were adjusted to match the curves of the corset. Skirts, particularly for traveling, were slit or made with wide pleats in order to facilitate walking. Suits were worn most often with accessories influenced by men's clothing, such as vests, shirts with wing collars, and men's hats. From 1890 to 1914, under the influence of sports, their form became more flexible: skirts flared, and less fitted jackets were freed from masculine criteria and standards. The swift adoption of the tailored suit led to its presentation in a variety of forms, with short or long jackets, for summer or winter, and for holidays or urban life. Sober and practical, its use was nonetheless coded. The garment was worn during the day for occasions on which no convention was required (shopping, walking, visiting).

In the early twentieth century, the popularity of the tailored suit tended to make it the uniform of the middle classes. Young women employed in new professions, such as office workers and elementary schoolteachers, adopted it as a professional uniform.



Solid and protective, like a coat, the tailored suit was mass produced, and its price thus made it accessible to a broad clientele. Department stores made it into a sale item. World War I accelerated changes. The tailored suit spread, becoming the war uniform of committed women wishing thereby to show their patriotism. The fashion press galvanized its use, thereby bringing together male and female wardrobes as well as blurring class distinctions.

### Haute Couture Becomes Interested

Couturiers expressed mistrust toward the tailored suit. The sober and comfortable appearance of the garment broke with the tradition of the ostentatious elegance of the Parisian houses. Similarly, the Anglo-Saxon influence was treated by the French fashion press with a certain contempt. The unquestionable superiority of London tailors in men's fashion was recognized, but there was firm opposition to any intrusion on their part into the universe of women's clothing. The first couturiers to introduce tailored suits in their collections in the early twentieth century were Jacques Doucet, Jeanne Paquin, and Paul Poiret, all creators who contributed to radical transformations in women's fashion. Jackets had a *Directoire* cut, a reminiscence of the eccentric elegance of the *Incroyables*. Coats, single-breasted and fitted, were high-waisted and usually made of fabric with broad stripes. However, when Paul Poiret launched the fashion for pencil skirts around 1911, after having liberated the torso from the corset, he imposed a new constraint, contrasting with the functional use of the suit.

Under the influence of the younger generation, from 1910 to 1925, the tailored suit became one of the favored garments of Parisian couture. Jeanne Lanvin, Gabrielle Chanel, and Jean Patou were the most ardent advocates of the new garment. The style of the Parisian suit set the tone for the rest of the world throughout the twentieth century.

Around 1910, the designs of Jeanne Lanvin blended the sporty informality of new men's fashion with youthful and refined elegance. The jacket was now worn open, revealing a simple blouse embellished with lace inserts, with a soft collar and no tie. Chanel, a beginner at the time, presented outfits made of soft jersey with an unfitted waist, large armholes, and short slit skirts facilitating walking. This very *avant-garde* version, which she had adopted from sports clothing, came together with the style imposed by the war in 1916. For her first advertisement, she chose three flowing suits with very short and flared skirts to show in *Vogue*.

### The Garçonne in the Tailored Suit

The sobriety of dress prescribed by the state of war became the rule in the 1920s. The modern democratic suit was worn night and day. The woolen suit, in masculine style, adopted the new straight and short line. The jersey outfit was extremely popular. Made of knitted wool, silk, or cotton, it was worn with a sweater taken from sporty

and American fashions. The boldest of suits of the time was no doubt the pants suit. After a timid appearance around 1890 for riding bicycles, in the form of culottes or bloomers, in the 1920s it was worn as broad trousers with a navy blue jacket, exaggerating the masculine silhouette that was fashionable in the jazz age. Softer, made of silk or printed cotton, the beach pajama was an addition to the summer wardrobe. On the ski slopes, elegant women displayed, with a degree of insolence, outfits of jackets, tunics, and pants in mountain style, the most fashionable made by Hermès. The use of this androgynous outfit, however, remained confined to emancipated and eccentric circles, typical of California or French Riviera lifestyles. Outfits made of flowing silk, dressier, decorated with geometric or exotic designs in rainbow colors, provided a new and more feminine version of the suit. Similarly, the evening suit, lamé, embroidered, and glittering, indicated an unbounded love of partying after years of privation. Jean Patou was the most representative designer of the period; his style, influenced by American lifestyles, gave his suits, which had a masculine and sporty spirit, a singularity that appealed to *garçonnes* and was gradually more widely imitated. The strict, straight, almost geometric appearance of these suits achieved sophistication through the use of very refined accessories. The images of the American actress Louise Brooks wearing his suits in films and photographs perpetrate the influence of the modernist style of Jean Patou.

### The Tailored Suit Advances

By the 1930s, the tailored suit had definitively entered the wardrobe of Western women, on many occasions replacing the dress as the garment of the bourgeoisie. Its sober appearance was reassuring, and it attenuated social, cultural, and even national differences. However, the cost of the garment made it hardly accessible to the working classes. It became the symbol of a degree of success for the middle class, worn by women at work as well as those who stayed at home. Often very subtle details, in terms of the quality of fabric, of cut, or of accessories, revealed the economic and social status of the woman who was wearing it.

Because of the economic crisis of 1929 and its political consequences in Europe, the rise of conservative and reactionary movements radically changed the image and the perception of the tailored suit. It lost its androgynous character for a newfound femininity.

The use of sporty suits, notably those made of jersey in favor in the 1920s, was limited to leisure activities. Beginning in 1931, the woolen suit worn in town emphasized feminine curves: it outlined the breast, emphasized the waist, and flared in widened basques on the hips. Skirts were longer and adopted a narrower line, created by pleats, darts, and complicated cuts. Suits often had a severe and feminine line, exaggerated by the adoption of shoulder pads. This almost martial style experienced its apogee in the success it achieved in the authoritarian and

totalitarian regimes of the period. Parisian couturiers, seized by the fad for neo-romanticism, decorated jackets in a manner increasingly distant from the original masculine cut, with lace, guipure, flowered-patterned linings, smocked shirtfronts, and jeweled buttons. The actress Marlene Dietrich stood out in contrast to this vogue, in which glamour and femininity went together, by appearing in films and in her life in men's suits made by the celebrated Austrian tailor Knize. In the 1930s and during the war, women in pants caused discomfort. The evening jacket, in a variant with a long dress, very fashionable in elegant circles, was the only exception to this general tendency. The suits made by Elsa Schiaparelli, influenced by the surrealist movement, with evening jackets richly embroidered with baroque and unexpected motifs, contributed notes of humor, derision, and refinement in a period that was conservative and conventional in taste.

In the postwar period, the style of Dior did not challenge this orientation. The New Look suits, with very feminine lines, were the continuation of a form of attachment to the past. The stiff jacket with broad shoulders, a fitted waist, and oversized basques was worn over wide pleated skirts, recalling the silhouettes of the eighteenth century and the Second Empire.

### A Classic of Fashion

From 1955 to 1965, Parisian couturiers made the tailored suit their showpiece. They gave it a second wind by adapting it to the transformations of the consumer society. Balenciaga was the first couturier to dare to break with Dior's New Look. His single-breasted, full, and flowing jackets once again underemphasized the breasts and the waist, recalling the style of the 1920s. Similarly, Chanel suits, in tweed and colored woolens, were a modern version of the first styles that had made the house's name. In the early 1960s, the tailored suit became an absolute must, immortalized by Jacqueline Kennedy. Despite the boldness of mini-suits by Courrèges and the very colorful versions by Cardin, young women, in open rebellion, had little taste for the garment, preferring an explicitly rebellious wardrobe: leather jacket, mess jacket, cardigan, and work jacket, which they mixed and matched, rejecting anything that could in any way evoke a bourgeois uniform. For young women, the tailored suit embodied a fashion that resembled a yoke. Only the pants suit, whose ambiguous and androgynous character corresponded to the prevailing nonconformism, found favor in the eyes of young women who had made the liberation of mores a veritable battle cry. The denim or corduroy version was for those who wore it a symbol of political commitment. Yves Saint Laurent was able to echo this movement of rebellion in his collections: car coats, safari jackets, Mao jackets, and dinner jackets were modern versions of the tailored suit.

The 1980s saw a revival of the fashion for the tailored suit, associating a certain taste for the classic with a representation of the consecration of women in the

world of work. Armani's suits were hugely successful among executive women; those of Chanel enjoyed renewed favor as symbols of relaxed luxury and elegance; and suits by Thierry Mugler and Christian Lacroix were baroque and festive. This rebirth was only an apparent one because the tailored suit was gradually losing its *raison d'être* and being replaced by other garments. The uniform no longer appealed to women at a time when fashion was governed by the cult of youth; the jacket had become a free element, and it alone continued to develop. Pants suits, like those of Jean Paul Gaultier, can still express, in a society where clothing taboos have largely faded, a way for women to emphasize their difference and their particularity.

See also **Chanel, Gabrielle (Coco); Doucet, Jacques; Paquin, Jeanne; Patou, Jean; Tailoring.**

### BIBLIOGRAPHY

- Breward, Christopher. *Fashion*. Oxford and New York: Oxford University Press, 2003.
- Chenoune, Farid. *A History of Men's Fashion*. Translated by Deke Dusinberre. Paris: Flammarion, 1993.
- Steele, Valerie. *Fifty Years of Fashion: New Look to Now*. New Haven, Conn.: Yale University Press, 2000.
- Waugh, Norah. *The Cut of Women's Clothes 1600–1930*. London: Faber, 1968.

*Xavier Chaumette*

**TAILORING** Tailoring is the art of designing, cutting, fitting, and finishing clothes. The word tailor comes from the French *tailleur*, to cut, and appears in the English language during the fourteenth century. In Latin, the word for tailor was *sartor*, meaning patcher or mender, hence the English "sartorial," or relating to the tailor, tailoring, or tailored clothing. The term bespoke, or custom, tailoring describes garments made to measure for a specific client. Bespoke tailoring signals that these items are already "spoken for" rather than made on speculation.

As a craft, tailoring dates back to the early Middle Ages, when tailors' guilds were established in major European towns. Tailoring had its beginnings in the trade of linen armorers, who skillfully fitted men with padded linen undergarments to protect their bodies against the chafing of chain mail and later plate armor. Men's clothing at the time consisted of a loosely fitted tunic and hose. In 1100 Henry I confirmed the royal rights and privileges to the Taylors of Oxford. In London, the Guild of Taylors and Linen Armorers were granted arms in 1299. They became a Company in 1466 and were incorporated into the company of Merchant Taylors in 1503. In France, the tailors of Paris (*Tailleurs de Robes*) received a charter in 1293, but there were separate guilds for Linen Armorers and Hose-Makers. In 1588, various guilds for French tailors were united as the powerful *Maitres Tailleurs d'Habits*. Tailoring has traditionally been and

remains a hierarchical and male-dominated trade, though some women tailoresses have learned the trade.

### Products

In the sixteenth and seventeenth centuries, tailors were responsible for making a variety of outer garments including capes, cloaks, coats, doublets, and breeches. They gave shape to them by using coarse, stiff linen and canvas for interlining, horsehair cloth and even cardboard stiffened with whalebone for structural elements. Imperfect or asymmetrical body shapes could be evened out with wool or cotton padding. Luxury garments were often lined with satins or furs to keep their wearers warm. Tailors were the structural engineers for women's fashions and made whalebone stays or corsets until the nineteenth century. Women largely made relatively unshaped undergarments and shirts for men, women, and children. The nineteenth-century tailor added trousers, fancy waistcoats, and sporting clothing of all sorts to his repertoire. The tailor was particularly adept at working woolen fabrics, which he shaped and sculpted using steam and heavy irons. Menswear had long used wool as a staple fabric. In Britain wool connoted masculinity, sobriety, and patriotism but in the early nineteenth century, it became extremely fashionable, almost completely replacing the silks and velvets used in the previous century. At the same time, men began to wear trousers rather than breeches and by the 1820s, tightly cut trousers or pantaloons could be worn as evening wear. Though they no longer made corsets, women's sidesaddle riding habits and walking suits remained the province of the tailor and were cut and fashioned from the same fabrics as male garments.

### Early Tailoring Manuals

Because tailoring was taught by traditional apprenticeships, skills were passed on from master to apprentice without the need for written manuals. The most skilled aspect of the trade was cutting out garments from the bolt of cloth. In G. B. Moroni's painting *The Tailor* (c. 1570), the fashionably dressed artisan prepares to use his shears on a length of cloth marked with tailor's chalk. These markings would probably have been based on a master pattern. The earliest tailors used cloth patterns because paper and parchment were too expensive at this period. Paper patterns became widespread and commercially available in the nineteenth century.

The earliest known tailoring manuals are Spanish. These are Juan de Alcega's *Libro de Geometric Practica y Traca* of 1589 and La Rocha Burguen's *Geometrica y Traca* of 1618. These books illustrate ways of drawing patterns to use fabric in the most economical manner, but have no information on technique. Later manuals, such as the important *L'Art du Tailleur* by de Garsault (1769) have more detailed instructions as to measurement, cutting, fit, and construction. The typical workshop had a master tailor, who dealt directly with the client and cut out garments. There might be several cutters in a large es-

tablishment and they were at the top of the tailoring hierarchy, for cutting out was the most skilled part of the trade. Under them other journeymen tailors were responsible for a variety of activities, including padding and sewing in interlinings, pockets, and the difficult task of assembling the sleeve and turning the collar, as well as manipulating the heavy shaping iron called a goose. Apprentices were usually responsible for running errands and sweeping up scraps of fabric before being taught basic sewing skills. When sewing machines were introduced, machinists, who might be women, were also added to the workshop floor. The tailors who sewed the garment together sat on a workbench near natural light with legs crossed, hunched over their work. To sit cross-legged in French is still to be *assis en tailleur*, or sitting in the tailor's pose.

The first manual in the English language is the anonymous *The Taylor's Complete Guide*, published in 1796. After this publication, there were many important manuals produced during the nineteenth century, including Compaing and Devere's *Taylor's Guide* (1855) and most importantly, E. B. Giles's *History of the Art of Cutting* (1889) which has been reprinted and provides great insight into the nineteenth-century techniques from a master tailor who knew many of its practitioners personally.

A spirit of competition and enterprise marked the first half of the nineteenth century, when tailors patented a multitude of inventions, manuals, systems of measurement, and fashion journals aimed at the man-about-town and his tailor. Some of the most important of these were the *Tailor and Cutter* and *West-End Gazette*. The endless cycles and revivals of women's fashions seemed illogical and capricious compared to the more rational, linear, and technologically innovative development of men's dress. The finest tailoring combined the principles of science and art to produce clothing that was both engineered and sculptural.

### Measurement

Systems of measurement changed radically during the history of tailoring. Tailors have always had the difficult task of creating three-dimensional garments for asymmetrical and highly varied body shapes. Unlike static sculpture, garments also had to allow the wearer to move freely and gracefully during their daily pursuits. Early tailors developed complex systems for measuring the bodies of their clients. However, as most manuals observe, no system could replace the observant eye and hand of the tailor, who noted the more subtle nuances of his client's posture and anatomy and could make allowances for a slight hunch, uneven shoulders, or a protruding stomach. In his tailoring manual of 1769, de Garsault illustrated the strip of paper he used for taking measure. His system involved cutting notches in the strip to measure the breadth of the back and the length of the arm to the elbow. Each client was measured against shifts in his own body's size and shape.



The modern tape measure was introduced in about 1800. In Britain, cloth had been accurately measured in ells (short for elbows), but the body was not quantified in units. In post-revolutionary France the metric system was used to measure the body, whereas British tailors favored inches. The tape measure was soon joined by a compass, ruler, and tracing paper to produce elaborate geometric systems used throughout the nineteenth century. These mathematical patterns could be produced in scaled sizes and were designed around the more abstract idea of a bodily norm or average. In their most elaborate forms these systems used machines like Delas's somatometer or body meter of 1839, which was an adjustable metal cage for measuring the bodies of clients. Entrepreneurs who used them to produce ready-made clothing in standardized sizes gratefully appropriated systems designed to ensure a more accurate fit. Reporting on the inroads made by ready-made tailoring exhibited at the 1867 World's Fair in Paris, Auguste Luchet wrote that the age of the sculptural tailors was over: "There are no more measurements, there are sizes ... Meters and centimeters. One is no longer a *client*, one is a *size eighty!* A hundred vestimentary factories are leading us toward the absolute and indifferent uniform." Though loosely fitting, ready-made clothing for the lower classes had existed since the seventeenth century, the nineteenth century saw the introduction of high-quality, fitted tailored garments sold off the rack.

### Shop Displays

The fully equipped tailor's establishment of the nineteenth and twentieth centuries could be sparsely or luxuriously fitted. The basic requirements of the trade included shelving for the display of cloth bales, a counter where swatches could be consulted, a space where the client could be measured, a fitting room with mirrors, a sturdy table for cutting out, and possibly blocks for saddles to fit riding clothes properly. Fashion prints were also hung as decoration or shown to clients as models. The shop might or might not include a space for workshops. More prestigious firms made garments on the premises while "jobbing" tailors sent bundles of pieces to outworkers, often women, who would assemble the garments at home or in sweatshops. At the top end of the scale, establishments like Henry Poole on Savile Row at the turn of the twentieth century combined more functional elements with the thick carpets, mahogany fittings, satin upholstery and gilded mirrors of the palace or exclusive gentlemen's club. In the twentieth century many tailors kept traditional interiors, though some, like Simpsons of Piccadilly and Austin Reed innovated with modern, Art Deco, or Bauhaus styles and included amenities such as barbershops. In the middle of the nineteenth century, the tailor was joined by hosiers, who specialized in high-end accessories and outfitters, whose trade was based on made-to-measure shirts, but who also sold suits, coats, hats, boots, and all manner of accessories. Their

shop window displays tended to emphasize orderliness and neatness to appeal to the male customer.

### Tailoring in the Twentieth Century

Bond Street, Savile Row, and St James's Street in the fashionable West End of London have been the center for elite, traditional tailoring since the turn of the eighteenth century. However, tailoring spanned the whole class spectrum, from tailors with royal warrants to immigrants working in the warehouses of the East End.

One of the most important shifts in Savile Row tailoring was the transition from a more traditional client base of British gentry and aristocracy to a more international, clientele including American financiers and eventually Hollywood celebrities. Though Savile Row rose to prominence in the late eighteenth century, dressing such figures as the Prince Regent and dandy Beau Brummel, in the twentieth it created the movie wardrobes of Fred Astaire, Cary Grant, and Roger Moore. Though many American stars sought the cachet of Savile Row, there were very talented tailors in the United States. In Harlem, the exaggerated shapes and bright colors of the zoot suit were launched by stylish young black men in the mid-1930s. When the War Production Board tried to curtail this "antipatriotic" tailoring because of wool rationing in 1942, race riots ensued. In Britain, there was a brief revival in elegant Edwardian tailoring after World War II, when so-called Teddy Boys—working-class men who spent large sums on their wardrobes—adopted it. In 1960s London, fashionable men's goods were democratized in the "Peacock Revolution," which saw the center of fashion gravitate toward Carnaby Street and the King's Road—along with Cecil Gee, John Stephen, John Michael, John Pears, Michael Rainey, and Rupert Lycett Green. One of the most important figures in the rejuvenation of menswear was the celebrity tailor Tommy Nutter. He created unique suits for both men and women, including suits for the Beatles, Mick and Bianca Jagger, and Twiggy.

In the 1980s, Italian tailoring began to receive more attention on the international fashion scene. With their "unstructured" suits, designers such as Giorgio Armani catered to a desire for more informal, lighter weight garments for both men and women. At the turn of the millennium, the Italian tailoring firm Brioni dressed the British movie icon James Bond, played by the actor Pierce Brosnan. In Britain, a new generation of designers combine the flawless cut and construction of traditional tailoring with the flair of haute couture. Oswald Boateng is an Anglo-Ghanian whose work displays a dazzling sense of color and who prefers to describe his work as "bespoke couture." Alexander McQueen, who trained for a short two years on Savile Row, also incorporates tailoring's emphasis on structure and materials into his couture womenswear.

Though it represents a very small part of the contemporary menswear market, custom tailoring still has

pride of place in the wardrobe of the sharply dressed man. Whether it applies to computer software or kitchens, the expression “tailor-made” still carries positive connotations of individualized, customized service. In the clothing trade, as long as the suit remains the classic form of formal attire, tailors will elegantly dress their clients. These may include men whose bodies may not fit the norms of the ready-made clothing industry, as well as royalty, businesspeople, or celebrities who turn to the tailor for a classic or innovative suit of clothing made to their precise measure.

See also **Armani, Giorgio; Cutting; Savile Row; Sewing Machine; Suit, Business.**

#### BIBLIOGRAPHY

- Breward, Chris. *The Hidden Consumer: Masculinities, Fashion and City Life 1860–1914*. New York and Manchester, U.K.: Manchester University Press, 1999.
- , ed. *Fashion Theory* 4, no. 4 (December 2000). Special issue focusing on “masculinities.”
- Chenoune, Farid. *A History of Men's Fashion*. Paris: Flammarion, 1993.
- Garsault, M. de. *L'Art du Tailleur* [The art of the tailor]. Paris: Académie Royale des Sciences, 1769.
- Giles, E. B. *The History of the Art of Cutting in England*. London: F. T. Prewett, 1887.
- Luchet, Auguste. *L'Art Industriel à l'exposition universelle de 1867* [Industrial art at the 1867 World's Fair]. Paris: Librairie Internationale, 1868.
- Walker, Richard. *The Savile Row Story*. London: Prion, 1988.
- Waugh, Norah. *The Cut of Men's Clothes, 1600–1900*. London: Faber and Faber, 1964.

*Alison Matthews David*

**TANNING OF LEATHER** It would not be an exaggeration to call leather the first human industry, since the wearing of animal skins goes back to the beginning of human existence. Before early humans mastered the art of weaving, skins from animals slain for food (with and without the fur) were utilized for garments, footwear, headgear, and protective clothing, as well as a host of practical applications, and were linked to warmth and to humans' very survival.

Before domestication of cattle and pigs, skins of deer and wild animals, as well as wild sheep and goats were dressed. Paleolithic cave paintings depict figures wearing skins and furs, and excavations at these sites have revealed an active leather industry. Flint instruments, including knives, scrapers, and awls used for removing flesh, have been found in addition to wooden poles and beams used for beating and draping hides. Later Neolithic and Bronze Age sites have yielded leather dagger sheaths, scabbards, shields, footwear, and jerkins of a sophistication that indicates that leather manufacture was mastered early in human history.

As humans learned to domesticate cattle, horses, sheep, goats, and pigs, the availability of raw materials for leather production swelled. Uses of leather by ancient peoples included all types of clothing, belts, thongs, footwear, headwear, gloves, ties, bags and vessels, armor, sheaths, packs, seat covers, saddles, animal trappings, tents, and even sails for ships. Excavations of Sumerian peoples at Ur of the Chaldees brought to light extraordinary leather tires used on wooden wagons. In the early 2000s, the Masai women of Africa were clad in cloaks and petticoats of leather, which harkened back to the earliest years.

#### Traditional Tanning Methods

Prehistoric humans quickly discovered that raw skins removed from the animal needed to be treated before they could be useful. Indeed, leather is a manufactured product that requires many steps. The series of chemical processes by which natural skins are converted to leather is known as tanning. The object of tanning is to render natural skins impervious to putrescence while imbuing them with greater pliability, suppleness, and durability. Early tanning methods employed natural substances, in contrast to modern manufactured chemicals.

However, before tanning can occur, the skins must be clean. Hides are washed of blood and dung and the hair removed. This process is not actually tanning, but a necessary preliminary step done by early peoples in a variety of ways. Some utilized alkaline substances to loosen hair, such as lime found in ash; others utilized urine to accelerate putrefaction and hair loosening; while still others such as the native Inuit peoples employed the enzymes in saliva via the chewing of skins. All cultures have employed stages of stretching and scraping of skins to remove flesh and hair prior to the actual tanning process.

The three historical methods of making leather are vegetable, oil, and mineral tanning. Oil tanning is considered to be the oldest process, probably employed in combination with smoke curing. Neolithic excavations have revealed elk and deerskins dressed with oil and smoked. Traditional oil tanning methods employ fish oils (of which cod oil is the most important) or animal fats worked (“stuffed”) into the hides to bring about oxidation, transforming skin into leather. Variations of oil tanning include the milk and butter used by nomads of Central Asia (Kyrgyz) and egg yolk tanning by peoples of northern China. Native Americans of North America are known to have tanned leather with a mixture of brains and oil. Smoke curing in pits has a long tradition in China.

Vegetable tanning, a 4,000-year-old process, was developed widely across the world by ancient peoples utilizing their own local flora. Plants containing tannins (compounds of gallic acid) infused in water were discovered as early as the Paleolithic period to affix to skins forming an impenetrable substance. Egyptians preferred using the mimosa plant for tanning purposes, while peo-

ples of the ancient Mediterranean employed sumach leaves. Oak (and pine) bark, nuts, and galls have been the most important sources for tanning compounds in Europe, practically until the advent of chemical processes in the nineteenth century.

Mineral tanning, until the modern age, meant alum. Ancient peoples mined alum for tanning skins in a process that became known as tawing. Tawed leather produced a supple, distinctive white leather and developed into a specialized guild in medieval Europe. Alum-tanned leather was developed to a particularly high standard in the Near East. The Moors, who conquered Spain in the eighth century, brought with them their expertise in this process; and the precious leather goods they produced, referred to as cordovan or cordwan, were indelibly associated with the city of Cordova, Spain, giving rise to the name of the leather shoemakers in England, known as cordwainers. Combination tanning, utilizing more than one method, was also exploited in making leather.

The importance of leather goods in all aspects of daily life made it a highly desirable trade item. Primitive peoples who needed leather for clothing, weapons, and other applications bartered goods for leather products. Leather became so vital to the flourishing of communities that it progressed into a form of currency. It has been used as money continuously throughout history. The historian Seneca noted that Romans used stamped leather money in 2 C.E.; so did the ancient Chinese early in the second century B.C.E. Even in sixteenth century Russia, leather pieces stamped with Czar Ivan IV's symbol were being used until metal currency took hold during the reign of Peter the Great.

### Decorating Leather

While leathers were often left with their simple tanned finish, the urge to color and embellish tanned leather has an equally early history. Coloring leathers was achieved through animal, but predominantly vegetable, dyes in combination with metal salts. Tawed leather accepts dye well and was a skill refined by ancient Phoenicians and Egyptians as indicated by the find of a 4,000-year-old fragment of leather dyed with kermes. Egyptians also employed safflower to stain leather. Indigo, woad, buckthorn, and hollyhocks were at various times utilized to dye leather in combination with mineral mordants. In addition to coloring, leather has also been decorated by peoples around the globe in various ways, including tooling, painting, embossing, pleating, perforating, plaiting, and embroidering to suit their tastes.

### Modern Tanning Methods

Interestingly, the tanning of leather was one of the last industries to lift itself out of medieval conditions in the nineteenth century. Before then, methods had endured for centuries. Modernization since the late nineteenth century, however, has been swift and complete, and what used to be a craftsman's art has become increasingly a

science handled by technicians. Mechanization has brought significant changes in speed and efficiency. Prior to specialized drum machinery, liming the skins, tanning, and dyeing was manipulated by hand. A wider range of tanning materials has also been introduced. Mineral tanning through chromium salt, which produces a supple, versatile leather, is by far the most widely used method of tanning in the early twenty-first century.

Even more significant are the myriad new methods of dyeing and finishing that have revolutionized the modern leather industry. Since their invention in 1856, aniline (synthetic) dyes have become universally standard in dyeing leather, producing an enormous range of colors and shades. This had a major impact on leather fashions in the twentieth century, bringing about innovative new looks hitherto unknown in natural leathers. Like dyes, finishing methods have revolutionized leather fashion. In the early 2000s, imperfect skins of any type—cow, pig, sheep, and goat—can be made to look identical to any other skin through sophisticated finishing processes such as sanding, plating, embossing, dyeing, and spraying. Pigskin, traditionally tough and used for shoe leather, has become an important and versatile garment leather through the modern finishing treatments, which represents a huge export product for China. Bulk industrial tanning is done less and less in Western Europe and America, having been shifted to India and the Far East, for economic reasons.

Some of the finest leather continues to be tanned by traditional methods, although it represents a tiny fraction of leather produced in the early 2000s. Among the most superior fashion and upholstery leathers are those processed by traditional vegetable tanning, piece-dyed by hand, and rubbed with oils to achieve a rich finish. Much of this luxury leather is produced in France and Italy, although a new industry is emerging in South America aimed at the high-end garment and fashion accessory market.

See also **Leather and Suede**.

### BIBLIOGRAPHY

- Gansser, A. "The Early History of Tanning." *Ciba Review* 81 (1950): 2938–2960.
- Hamilton, William L. "The Private Life of Club Chairs." *New York Times* (22 January 1998): F1.
- Issenman, Betty Kobayashi. *Sinews of Survival: The Living Legacy of Inuit Clothing*. Vancouver: UBC Press, 1997.
- Kaufman, Leslie, and Craig S. Smith. "Chinese Pigs Feed a Western Fashion Boom." *New York Times* (24 December 2000).
- Reed, Richard. *Ancient Skins, Parchments, and Leathers*. London: Seminar Press, 1972.
- Waterer, John William. *Leather in Life, Art, and Industry*. London: Faber and Faber, 1946.

*Lauren Whitley*

**TAPA.** See **Bark Cloth**.



**TAPESTRY** Since early medieval European times tapestry's major purpose has been well-established as the making of large pictorial wall hangings. This use of a 3000-year-old textile structure has been held as standard, particularly in western society, right through to the twentieth and twenty-first centuries.

Out of central Asia and over many centuries the kilim rug, using the same woven structure, has established a highly respected role as a religious, decorative or a simply functional floor covering, and domestic application abounds in the modern world. One should recognize, too, tapestry as an upholstery fabric for chairs and sofas, not an inconsiderable application in the eighteenth, nineteenth, and into the twentieth century.

However, as recently as the late 1990s, the discovery of woven garments in burial sites in a remote area of central Asia—garments with extensive use of woven tapestry as part of their construction—further identifies what can be argued as tapestry's widest application over world history: tapestry as clothing. These particular garments date from between 200 B.C.E. and 200 C.E. and were unearthed from sites in the remote town of Shampula, once part of the ancient southern silk route. They are woolen skirts and have graphic pictorial bands as inserts, set horizontally around the entire circumference and range between 2 to 8 inches (5 to 20 cms) high. When considered alongside the use of tapestry in the woven tunics of Coptic Egypt, in the application of diverse items of clothing in pre-Columbian Peru and the knowledge of Chinese Kessi or silken tapestry robes, there is reason to believe that this medium had a wide purpose beyond that of creating wall hangings. This is not in any way to diminish the richest of history of the mural tapestry; rather, it is to recognize that the evidence we have of dry desert-like conditions (Egypt, coastal Peru and the Mongolian region) having preserved such clothing, this application could have been even more widespread in less protective climates.

In Egypt, roughly between 300 to 800 C.E., the Copts, a Christian sect in that country, are known for the application tapestry to clothing. This process was employed particularly in the construction of linen cloth garments where passages of colored wool and undyed linen tapestry were woven as an integral part of the plain all linen cloth in the form of roundels, rectangles and vertical bands. Such garments, simple rectangular sleeved tunics, were clearly in regular use. As wear took place on more vulnerable areas of the plain linen cloth, the tapestry passages, with their highly evolved, sophisticated and complex imagery, would be cut out and patched onto entirely new plain woven tunics. That they were subsequently used as burial garments after frequent daily use suggests that such tunics were of significant value to the wearer. There is also strong argument to suggest that this developed skill of woven tapestry, which was also employed in complex wall hangings in religious and cere-

monial architecture in Egypt, has direct links to the emergence of the large mural tapestries in northern and western early medieval Europe. However there is little or no evidence to suggest that tapestry as clothing made this northern journey.

In South America, particularly in the coastal and western Andes region that is now Peru, and during the period between 200 B.C.E. and 1600 C.E., tapestry vestments were clearly widespread in use. These were short, square, sleeveless tunics of a seemingly military, almost heraldic appearance. They were often of an entirely tapestry construction, sometimes of simple contrasting checkers or of an extremely evolved figurative iconography which could be seen as complex pattern to the less experienced viewer. The range of application was for domestic, ceremonial, regal, military or symbolic use, for identifying groups of individuals and as burial clothing. They were used as tunics, mantles, masks, hats, belts, shrouds, shoes, even gloves. And the technical skills employed in the weaving were of the highest order, of great inventiveness and on a level that is hardly understood, let alone practiced in the early twenty-first century.

Given the extensive history here described, it is surprising that in the early twenty-first century and particularly in the world of high fashion, tapestry has virtually no presence. There may have been brief individual experiments that never emerged to sufficient degree except to hint at a potentially rich vein of expression. One example may have been a gentleman's tapestry vest (waistcoat) worn by the designer that was made of complex pattern in black, gray, white and much silver metal. It was quite stunning but most often concealed behind a nondescript button jacket. In London two of the ancient guilds, that of the wax chandlers and the cappers and felter, in the 1960s and 1970s made ceremonial robes for their chief office bearers. Both garments were full length silk with quite extensive tapestry woven insets. The main dignitaries of London's Royal College of Art wore black silken robes. The collar, which is some 16 inches (40 cms) square and hangs down the wearer's back, depicts a stylized phoenix bird in sparkling gold metals, (the college symbol), while the robe's front facings fall all the way to the floor. These are wide, flame-like golden bands, even having extensions to fit the height of different dignitaries.

Perhaps the nearest approach to tapestry as clothing in the western world emerged at the peak of medieval tapestry. Great skill and design was employed in illustrating the nature of the complex vestments of the individuals illustrated in that period. By the use of wool, linen, and silk the cloaks, robes, tunics, hats and hose imitated all fabrics and fashions of the relevant period. This practice was employed to such a degree that, if not otherwise known, the precise dates of the making of these tapestries can be established. The extremely labor intensive nature of this ancient craft—tapestry—makes it very costly cloth for the smallest areas.

See also **Africa, North: History of Dress; America, South: History of Dress; Textiles, Byzantine; Textiles, Chinese.**

#### BIBLIOGRAPHY

Kybalova, Ludmila. *Coptic Textiles*. London: Paul Hamlyn, 1967.  
L. L. Editores. *The Textile Art of Peru*. Lima, Peru: Jiron A Miro Quesada Lima.

*Archie Brennan*

**TARTAN** This cloth has powerful connections with often-romanticized notions of Scottish identity and history. Tartan has also been widely used as a fashion textile owing to the appealing and distinctive nature of its various patterns, which are known as *setts*.

#### Origins and Development

The precise origins of tartan are not known; however, a fragment found in Falkirk, which dates from the third century C.E., suggests that simple woolen checked cloths existed in Scotland at an early period. Complex patterning of the type now associated with tartan did not exist in Scotland until the sixteenth century. Hugh Cheape discusses the origins of the name tartan as follows:

The word “tartan,” probably French (from the word *tiretaine*), was in use early in the sixteenth century.... It seems likely that in some way that we can’t now trace, this word came to describe the fabric we now call tartan. (p. 3)

Contrary to contemporary popular belief, tartan patterns have no traceable historical links with specific Scottish families or clans. These associations developed from the early nineteenth century, when they were actively promoted by historians and writers, as well as woolen manufacturers and tailors. Tartan, however, was by 1600

---

established as part of the culture of the Highlands of Scotland. It was widely worn by all levels of that society and it formed a distinctive element of Highland dress, which was largely based around the plaid or *breacan*. Men wore the plaid belted, and women adopted it as a large shawl. Up until the late eighteenth century, the *setts* worn were largely determined by the locality and the tastes of the weaver and purchaser.

#### Culloden and After

The battle of Culloden in 1745 was the last stand in the campaign by supporters of the Catholic Prince Charles Edward Stuart, to form a challenge to the ruling Hanoverian King, George II. Owing to his family’s Scottish origins and the support he had from the largely Catholic Highlanders, the “Young Pretender” promoted Highland dress as the uniform of his Jacobite army. This led to tartan being associated with political rebellion and sedition and to its proscription under the Disarming Act of 1746. Under this act, the wearing of tartan was forbidden, with the penalty of possible transportation for seven years. In addition to the brutal repression that followed Culloden, these measures, which lasted until 1782, began to put an end to the distinctive Highland way of life.

The fact that tartan survived this period of dramatic social and political change was also linked to the actions



In 1746 the following law was passed:

[N]o man or boy within . . . Scotland, shall, on any pretext whatever, wear or put on the clothes commonly called Highland clothes (that is to say) the Plaid, Philabeg, or little Kilt, Trowse, Shoulderbelts, or any part whatever of what peculiarly belongs to the Highland Garb; and that no tartan or party-colored plaid or stuff shall be used for Great Coats or upper coats, and if any such person shall presume after the said first day of August, to wear or put on the aforesaid garments or any part of them, every such person so offending . . . shall be liable to be transported to any of His Majesty’s plantations beyond the seas, there to remain for the space of seven years. (Disarming Act of 1746)

of the British government. After Culloden, a systematic effort was made to divert Highlanders away from Jacobite adventure and toward the cause of British imperial war. The Highland regiments formed at this period were exempt from the ban on Highland dress, and the British establishment decided to make use of tartan in their uniforms to encourage martial kinship amongst their recruits. The Highland regiments' involvement in British imperialist expansion, and the fact that their role was somewhat over-represented in imagery, helped to spread the popularity of tartan internationally. New military *setts* were designed by tartan manufacturers beginning in 1739 with the original "government tartan," a design of green, blue, and black, usually known as the Black Watch.

From the early nineteenth century tartan began to be internationally recognized as representative of Scottish, rather than merely Highland Scottish, identity. Its popularity was linked to romanticized notions of Scottish history put forward by writers such as the poet James MacPherson in his dubious translations of the work of the Gaelic bard Ossian. The more credible literary works of Sir Walter Scott also increasingly captured the public imagination. Scott played a significant role in orchestrating the well-publicized visit of King George IV to Edinburgh in 1822, during which the monarch appeared in a version of full Highland dress. This royal endorsement of tartan was continued from the 1840s by Queen Victoria, and was a great stimulus to its fashionability in Britain, France, and elsewhere.

### Manufacture and Design

From the mid-eighteenth century, tartan design and manufacture began to be carried out within large-scale commercial enterprises, rather than primarily being the concern of local weavers. The firm Wilson's of Bannockburn was the most prominent tartan manufacturer from the mid-eighteenth to the mid-nineteenth centuries and Cheape claims that they "were mainly responsible for creating tartan as we know it today" (Cheape, p. 52). Their archive indicates that they catered to a fashionable market eager to consume new patterns named either after ancient clans or popular Scottish figures such as Sir Walter Scott. In addition to their prodigious innovation in tartan design, they also contributed to the modernization of tartan manufacture by "regularizing the sett, colors, and thread count" involved with each design (Rawson, Burnett, and Quye, p. 20).

Throughout the twentieth century tartan retained its role as both an internationally recognized symbol of "Scottishness" and as an attractive fashion textile. Tartan is currently widely worn by Scots as Highland dress on formal occasions and also to sporting events. Since the 1970s tartan has featured in the subcultural dress of skinheads, rockabillys, and punks, as well as being prominent in the work of international designers such as Vivienne Westwood, Jean Paul Gaultier, and Alexander McQueen.

See also **Kilt; Scottish Dress.**

### BIBLIOGRAPHY

- Cheape, Hugh. *Tartan, the Highland Habit*. 2nd ed. Edinburgh: National Museums of Scotland, 1995.
- MacKillop, Andrew. *"More Fruitful than the Soil": Army, Empire and the Scottish Highlands, 1715–1815*. East Linton, U.K.: Tuckwell Press, 2000.
- Morgan, Kenneth O. *The Oxford History of Britain*. Oxford: Oxford University Press, 2001.
- Rawson, Helen, John Burnett, and Anita Quye. "The Import of Textile Dyes to Scotland: The Case of William Wilson and Son, Tartan Weavers of Bannockburn, 1780–1820." *Review of Scottish Culture* 13 (2000–2001): 18–29.
- Scarlett, James D. "Tartan: The Highland Cloth and Highland Art Form." In *Scottish Textile History*. Edited by John Butt and Kenneth Ponting. Aberdeen, U.K.: Aberdeen University Press, 1987.
- . *Tartan: The Highland Textile*. London: Shephard Walwyn, 1990.

Fiona Anderson

**TATTOOS** Tattooing is a process of creating a permanent or semipermanent body modification that transforms the skin. The word tattoo comes from the Tahitian *tatau*, which means "to mark something"; it is also hypothesized that the term comes from the sound the tatau sticks make when clicking together to mark the skin with ink. Tattooing is a process of puncturing the skin and depositing pigments, usually indelible ink, by a variety of methods beneath the skin to create a desired design or pattern. Tattoos range from "blackwork," large areas of heavy black ink in designs, to fine details and elaborate color schemes including fluorescent inks.

### Historic Tattoos

The earliest evidence of tattooing includes tattooing tools and tattooed mummies. At 10,000-year-old sites in Tanzoumaitak, Algeria, tattooing instruments used for puncturing the skin were found with the female tattooed mummy of Tassili N'Ajje. In 1991, Ötzi, a Stone Age male mummy, was found in the Ötztal Alps, bordering Austria and Italy. This mummy had numerous tattoos, which were hypothesized as being used for medicinal cures, spiritual ceremonies, or indicating social status. Two well-preserved Egyptian mummies from 4160 B.C.E., a priestess and a temple dancer for the fertility goddess Hathor, bear random dot and dash tattoo patterns on the lower abdomen, thighs, arms, and chest. In 1993, a fifth-century B.C.E. Ukok priestess mummy, nicknamed the Siberian Ice Maiden, was found on the steppes of eastern Russia. She had several tattoos believed to have had medicinal, spiritual, and social significance. Most of the 4,000-year-old adult mummies from Xinjiang, China, had tattoos that related to their gender or social position.





**A Japanese artist tattoos a pattern to a customer's back, 1955.** These elaborate and symbolic Japanese tattoos became a popular fashion during the late eighteenth to nineteenth century. © BETTMANN/CORBIS. REPRODUCED BY PERMISSION.

Classical authors have written about tattoos used by the Thracians, Greeks, Romans, ancient Germans, ancient Celts, and ancient Britons. Tattooing has been practiced in most parts of the world, although it is rare among people with darker skins, such as those of Africa, who more often practice scarification and cicatrisation. Scholars hypothesize that tattooing was a permanent version of the desired aesthetic of body painting. Motivations, meanings, and exact techniques relating to tattoos vary from culture to culture. Tattoos have emphasized social and political roles; indicated cultural values and created an identity for the individual; reinforced aesthetic ideals; encouraged sexual attraction; eroticized the body; served medicinal and healing roles; communicated group affiliation or membership, and emphasized ritual and spiritual roles and customs of a culture.

**Polynesia.** In 1787, a French expedition led by Jan Françoise de la Perouse landed on Samoa and reported the

men's thighs were heavily painted or tattooed, which gave the appearance of wearing pants. Samoan tattoos were applied with ink, tattoo combs, and hammer. Male tattoos had larger black areas than females, who had lighter, more filigreed lines.

**Borneo.** In the nineteenth century, Americans with tattoos were sailors and naval personnel, who wrote about their tattoo experiences in ships' logs, letters, and journals. During World Wars I and II, some U.S. soldiers and sailors decorated their bodies with tattoos. Usually these tattoos were from a set of stereotypical symbols—courage, patriotism, and defiance of death—later referred to as “flash.” In the early 2000s, flash includes a wide variety of stock art used for tattoos.

**Central America.** In the nineteenth century most of Europe did not allow tattooing because the Catholic Church admonished it. However, tattooing flourished in Eng-

land, due primarily to the tradition of tattooing in the British Navy. Many British sailors returned home with tattoos that commemorated their travels, and by the eighteenth century most British ports had at least one tattoo practitioner in residence.

In 1862, Prince Edward of Wales had a Jerusalem cross tattooed on his arm to commemorate his visit to the Holy Land. Later, as King Edward VII, he acquired additional tattoos, and even instructed his sons, the Duke of Clarence and the Duke of York (King George V), to obtain tattoos to commemorate their visit to Japan.

In 1941, the Nazis registered all prisoners entering the Auschwitz concentration camp who were not ethnic Germans with a tattooed serial number. This tattoo was first placed on the left side of the chest; later, the location was moved to the inner forearm.

### Contemporary Tattoos

During the latter part of the twentieth century, tattoos were primarily utilized by microcultures, such as motorcycle gangs, street gangs, and punks. In the twenty-first century, tattoos have gained popularity in Western culture and become commonplace and even fashion statements.

At the same time, some microcultures, such as the Modern Primitives, have sought alternative and perhaps more extreme tattooing methods and designs. Often these methods and designs have been borrowed from anthropological texts about ancient cultures and related tattooing practices. There are tattoo practitioners who specialize in “tribal tattoos” and “primitive technologies.” “Tribal tattoos” are typically heavy black ink and focus on designs that resemble Polynesian designs, ancient Celtic knotwork, or archaic languages. “Primitive technologies” include a wide variety of manual tattoo application methods, such as sharpened bones and ink; bone combs, hammer and ink; and tatau sticks and soot-based ink. These methods require lengthy tattooing sessions even for the smallest tattoos.

### Electric Tattooing Practices

In 1891, the first electric tattooing implement was patented in the United States. In the early twenty-first century, many tattoos are applied in tattoo parlors using hand-held electric tattooing machines controlled by a foot pedal. These machines have a needle bar that holds from one to fourteen needles. The type or specific area of the tattoo design being worked on determines the number of needles. A single needle is used to make fine, delicate lines and shading. Additional needles are used for dense lines and filling with color. Even with the use of all fourteen needles, large or heavily detailed tattoos could take several months to complete.

Each needle extends a couple of millimeters beyond its own ink reservoir, which is loaded with a small amount of ink. Only one color is applied at a time. The tattoo practitioner holds the machine steady and guides the dye-

loaded needles across the skin to create the desired pattern or design. A small motor moves the needles up and down to penetrate and deposit ink in the superficial (epidermis) and middle (dermis) layers of the skin.

### Tattoo Health-Related Risks

Licensed tattoo establishments are required by law to take measures to ensure the health and safety of their clients. Since puncturing the skin and inserting the inks cause inflammation and bleeding, precautions are taken to prevent the possible spread of blood-borne infections, such as hepatitis B and C. Rooms used in the tattooing process are disinfected before and after each client. An autoclave, a regulated high-temperature steamer that kills blood-borne pathogens and bacterial agents, is used to sterilize the needle bar and reservoirs before each tattoo session. Sterile needles are removed from individual packaging in front of the client. The area of skin to be tattooed is shaved and disinfected by the tattoo practitioner. During the tattooing process, the skin is continually cleaned of excess ink and blood that seep from punctures with absorbent sanitary tissues.

### Tattoo Removal

Tattoos have become part of fashion trends, resulting in the need for effective tattoo removal. Past methods of removing tattoos have often left scars. Tattoo removal with laser technology has become the most effective method used and has a minimal risk of scarring. Despite advances in laser technology, many tattoos cannot be completely removed, due to the unique nature of each tattoo. Successful tattoo removal depends on the tattoo’s age, size, color, and type, as well as the patient’s skin color and the depth of the pigment.

### Semipermanent and Temporary Tattoos

Cosmetic tattoos are semipermanent makeup, such as eyeliner and lip color, tattooed on the face. These tattoos use plant-derived inks that are deposited in the superficial skin layer, resulting in a tattoo that lasts up to five years. Temporary tattoos come in a wide variety of designs and patterns. Unlike permanent and semipermanent tattoos, most temporary tattoos can be applied and removed by the wearer. These tattoos are burnished onto the skin and secured with an adhesive. Most temporary tattoos can be removed with soap and water or acetone, depending on the adhesive. Another type of temporary tattoo is henna or *mehndi*, which is a shrublike plant that grows in hot, dry climates, mostly in India, North African countries, and Middle Eastern countries. The leaves are dried, ground into a powder, and made into a paste, which is applied in desired designs to the skin. After several hours of drying, a reddish-brown stain temporarily tattoos the skin. This tattoo begins to fade as the skin exfoliates and renews itself.

*See also* **Body Piercing; Scarification.**

## BIBLIOGRAPHY

- Beck, Peggy, Nia Francisco, and Anna Lee Walters, eds. *The Sacred: Ways of Knowledge, Sources of Life*. Tsale, Ariz.: Navajo Community College Press, 1995.
- Camphausen, Rufus C. *Return to the Tribal: A Celebration of Body Adornment*. Rochester, Vt.: Park Street Press, 1997.
- Demello, Margo. *Bodies of Inscription: A Cultural History of the Modern Tattoo Community*. Durham, N.C.: Duke University Press, 2000.
- Gilbert, Steve. *Tattoo History: A Source Book*. New York: Juno Books, 2001.
- Hadingham, Evan. "The Mummies of Xinjiang." *Discover* 15, no. 4 (April 1994): 68–77.
- Polosmak, Natalya. "A Mummy Unearthed from the Pastures of Heaven." *National Geographic* 186, no. 4 (October 1994): 80–103.
- Simmons, David R. *Ta Moko: The Art of Maori Tattoo*. Auckland: Reed Methuen Publishers, Ltd., 1986.
- Tanaka, Shelley. *Discovering the Iceman: What Was It Like to Find a 5,300-Year-Old Mummy?* Toronto: The Madison Press, Ltd., 1996.

Theresa M. Winge

**TEA GOWN** The tea gown is an interior gown that emerged in England and France in the 1870s at a time when increased urbanization affected social behavior. The growing number of etiquette manuals and lady's periodicals produced at this time contributed to the revival of teatime by the middle classes and to the adoption of a whimsical type of gown worn by hostesses in their homes at five o'clock tea. Marked by Victorian eclecticism, this unique gown often incorporated elements of fashionable European dress from previous centuries, with exotic fabrics and stylistic components of foreign dress. The tea gown provided respectable women with an outlet for fantasy and innovation within the codified system of nineteenth-century dress and behavioral codes.

The nature and origin of teatime had considerable impact on the development of tea gowns. As tea was worth its weight in gold at the time of its introduction in Europe in the early seventeenth century, its consumption was reserved for the elite. Although this exotic beverage had become widely accessible in Europe and America by the mid-eighteenth century, tea drinking had been established as a class-conscious social event through which a network of selected individuals attained group membership. A sign of hospitality and politeness, serving tea to one's friends and relations retained an air of gentility and exclusivity that appealed to the rising middle classes. This mode of refined social entertainment entailed distinct refreshments, equipment, and rituals and would foster the emergence of a distinctive form of dress.

Specialization was also perceptible in interior spaces and manners, and gave rise to the development of the

dining room and parlor. Both have significance in the tea gown's rise in popularity. The emergence of the dining room and the refinement of table etiquette in the mid-nineteenth century led to increased cost and formality when hosting dinners to repay social obligations and entertain friends. In comparison, teatime was far less costly and formal and could host a greater number of individuals, as custom required that guests stay between fifteen minutes and half an hour. With increased urbanization, social circles expanded rapidly and teatime became a more accommodating and feasible event in a system of reciprocity that was often daunting, and where hosting anxieties were on the rise. The parlor was in nature more flexible and became a stage for public display where teatime was held. As socializing was frequently conducted in private residences, home was also a public stage, and many late nineteenth-century parlors aimed to convey to visitors the owners' artistic sensibilities. This contributed to the popularity of the tea gown, which was considered to be the appropriate form of dress for artistic and exotic features. Many such gowns were aesthetically coordinated with their surroundings. This also influenced artist James Abbott McNeil Whistler and architect Henry van de Velde to design tea gowns for sitters or clients.

As teatime had long been conducted in private residences, the type of gown worn for the occasion was derived from interior gowns, which fit into the category of "undress." Nineteenth-century dress code was mainly divided in three categories: "undress," "half dress," and "full dress." Although this classification suggests a crescendo from least to most formal, elevated levels of formality existed within each category. As both men and women participated in social tea-drinking, and because teatime could be attended by distant acquaintances, tea gowns worn by hostesses did not stray far from Victorian propriety and became very formal interior gowns that were fit for public exposure. The state of "undress" could thus include gowns that were loose or semi-fitted to those, like the tea gown, that could be as fitted as other day and evening dresses. However, artistic elements such as Watteau pleats (wide pleats emerging from the center back neckline borrowed from eighteenth-century gowns) and draped front panels were among the features often added to a fitted understructure that gave the impression of looseness. These elements gave way to very elaborate interior gowns that were not labeled as "tea gowns" until the late 1870s.

The earliest labeled tea gowns discovered to date appeared in the 1878 British periodical, *The Queen, The Lady's Newspaper*. These one-piece gowns with long sleeves, high necklines, and back trains were made to give the impression of being closely fitted open robes with under dresses. One had the Watteau pleats and was named "The Louis XV Tea Gown." This is of interest as it names its source of inspiration and reinforces the eighteenth-century salon connection that was mentioned by writers



of the period, and helped to intellectualize and elevate the status of teatime. Such tea gowns co-exist with numerous other elaborate interior gowns of the same style, which, until the turn of the century, were as likely to be named with the new term “tea gown” as they were to be labeled by the variant French term, *robe de chambre*. The words *robe* and *toilette* were also used interchangeably, as were *chambre* and *intérieur*. Terminology is thus a problem because tea gowns were derived from interior gowns, but not all interior gowns were fit to be worn in mixed company at teatime.

Nineteenth-century tea gowns seen in fashion plates followed the bustling styles of their times, and descriptions mentioned elaborate fashion fabrics and trims. This serves to differentiate these gowns further from other interior gowns. Although loose and artistic features were acceptable in tea gowns, their public use mandated the adoption of the fashionable and highly-fitted silhouette.

As wearing underpinnings such as bustles without a corset was not a Victorian practice, the contrived fashionable silhouette present in tea gowns observed in fashion plates and in surviving specimens in museum collections suggests that corsets were worn under some of these gowns.

From the late 1870s to the mid-1910s, tea gowns were immensely popular. Their magnificence was on the rise and leading designers joined in with fanciful creations that could easily have been mistaken for fancy dresses.

As Edwardian dress gave rise to a love of different colors and fabrics and introduced Empire revival features in high fashion, a progressive blurring occurred. The appropriateness of historically inspired gowns with looser and exotic elements was no longer confined to teatime. This also expanded the tea gown’s use to other day and evening events. As the revivalist Empire silhouette gained ground and exoticism became the rage, it became hard to differentiate tea gowns from other types of gowns. Changes also occurred in the physical settings of teatime, which migrated to newly-popular tea pavilions and helped the *thés dansants* of the 1910s supersede teatime in the home as the fashionable thing to do.

See also **Empire Style; Europe and America: History of Dress (400–1900 C.E.); Robe.**

#### BIBLIOGRAPHY

- Kasson, John F. *Rudeness and Civility: Manners in Nineteenth-Century Urban America*. New York: Hill and Wang, 1990.
- Roth, Rodris. “Tea-Drinking in Eighteenth-Century America: Its Etiquette and Equipage.” In *Material Life in America, 1600–1860*. Edited by Robert Blair St. George. Boston: Northeastern University Press, 1988, pp. 439–462.
- Montgomery, Maureen E. *Displaying Women: Spectacles of Leisure in Edith Wharton’s New York*. New York: Routledge, 1998.

Anne Bissonnette

**TECHNO-TEXTILES** Techno-textiles are fabrics that incorporate new technologies and new functionality into a traditional textile material. Sometimes called “tech-textiles” or “technical fabrics,” most techno-textiles have their roots in industrial or military applications. Techno-textiles are employed in many different applications, ranging across biomedical devices, aircraft, automobiles, electronics, and more, including clothing and home furnishing.

Textiles are products basically constructed of fibers. These fibers are frequently twisted together (thousands at a time) to create yarns, and the yarns can be woven, knitted, or braided to make fabrics. When looking at a fabric, it is easy to forget that fabric is really made of thousands or millions of small fibers. However, the fibers are the most important component of the textile. The choice of fibers and yarns can change the behavior of the textile material. Most techno-textiles are developed at the fiber level. By modifying materials thinner than a human hair, the performance of a fabric can change dramatically.

Since the dawn of synthetic plastics, techno-textiles have been marketed. One of the earliest examples of fibers made for high-tech application is nylon. As the air force was developing as a significant component of the armed forces, parachutes became more and more important. Parachutes were made from woven silk fabric. Researchers were interested in developing a synthetic substitute for silk to control quality, source, and improve strength. Nylon was an ideal source and rapidly developed to satisfy this market.

Recognizing nylon as a silk substitute, however, quickly led people to consider other products made from silk as candidates for nylon. Stockings, which were extremely popular and rather expensive at the time, were identified as a likely market. The success was so great that the public started calling stockings “nylons” within a few years. The increased strength and durability of the nylon compared to silk made this a tremendous success.

By the early 2000s, nylon was no longer considered a techno-textile, but rather a commodity fiber. This continues to happen: as new technologies become commonplace and accepted, they cease to be considered high-tech. What at first seem like fantastic applications will likely, within years or decades, become commonplace.

#### Comfort through Technology

One of the most popular applications of techno-textiles is to provide comfort in a garment. Generally speaking, there are two aspects of comfort that clothing can address: perspiration and temperature. A comfortable garment will take moisture away from the body and maintain a good temperature level.

**Moisture control.** Expanded polytetrafluoroethylene (ePTFE) has transitioned from the laboratory to apparel. PTFE is the same chemical structure as Teflon, but when

it is expanded, some unique properties can be realized. Gore popularized this technology as the Gore-Tex membrane. The basic idea is that the membrane has very small holes in it. These holes permit water vapor to pass, but are too small to allow a water droplet through. Thus, if a person wearing this garment is perspiring, the water vapor can move through the membrane. However, if it is raining, the droplets cannot pass through to make the person wet.

**Temperature control.** Phase change materials are becoming quite popular as a way to control temperature in a garment. Basically, microencapsulated waxes are embedded into the fabric. When the wax melts, it absorbs thermal energy, effectively cooling the material when it is heated. Conversely, when the molten wax solidifies, it releases heat while the overall system is cooling. The result of this is a material that tries to maintain a certain temperature, effectively taking the peaks of heat and cold away.

There are methods to actively change the temperature of clothing as well. Astronauts, aircraft test pilots, and racecar drivers have been using refrigerated clothing for some time. Tubes of coolant are embedded in the clothing and a small pump pushes the cool liquid throughout the garment. Thermal-electrical devices are also being considered.

### E-Textiles

Some of the more exciting possibilities for techno-textiles come from using modern electronics and computer technologies in clothing. The key elements are the use of electrically conductive fibers or yarns so that signals can be sent throughout the garment, flexible power sources, flexible computer equipment, and flexible display systems.

Conductive materials in fibrous form, such as metals or carbon, or even conductive polymers such as polyaniline, can be used as wiring within a piece of fabric. These wires can carry electricity to various components, such as sensors, actuators, or computer chips, that are embedded in the garment. Wireless communication devices can communicate information to and from the clothing.

For example, Infineon Technologies, AG, is developing a method to incorporate motion detection devices into carpeting. This can be used for a variety of purposes, including controlling lighting to turn on when someone enters the room, or to detect intruders. In addition to detecting motion, the chip can measure temperature, which could lead to applications such as automatic floor lighting in the event of a fire, showing the occupants a path to safety.

The motion detection module is woven into the carpet backing. Red wires supply voltage, green wires carry data, and blue wires are ground for Infineon's demonstrator smart carpet motion-detection module. A capacitive sensor in the module detects when a green wire is touched, which lights the red LED.

Optical fibers can be incorporated into fabric structures in such a way as to create light patterns on the surface of the fabric. By proper control, the fabric can effectively become a television or computer screen. France Télécom demonstrated such a technology—a fabric display screen. Eventually this technology could be incorporated into everyday clothing or home furnishings. Imagine a simple, businesslike shirt that can be converted into a dynamic flashing nightclub outfit with the flip of a switch. Draperies and wallpaper could become display units so that the pattern or color scheme can be changed to the owner's instantaneous desire.

Maggie Orth has developed Electric Plaid for this purpose. Electric Plaid doesn't work by controlling fiber optics, but rather by controlling temperature-sensitive dyes—another techno-textile application. Temperature-sensitive dyes can change color depending on how cold or hot the fabric becomes. Electric Plaid has heating and cooling filaments embedded in the fabric. By changing the degree of heating and cooling at different places in the fabric, Orth has created a fabric that changes color and pattern slowly throughout the day.

**Embedded sensors.** Sensors to determine such disparate phenomenon as temperature or oxygen content can be created in a fibrous form. Typically these are fiber optics that have Bragg diffraction gratings that can measure small changes in the environment. Because they are produced as fiber optics, they can be incorporated into clothing. A number of companies, such as Big Light and SensaTex, have embedded these sensors into underwear so that the fibers are touching or close to the human body.

The information received by these sensors can be transmitted to another location. Some of the life-critical applications for these include infant garments to provide early warning against SIDS (Sudden Infant Death Syndrome), and for soldiers. In either case, information can be sent back to the parents or commander to provide details about the health and well being of the wearer. Should a problem arise, quick response can prevent serious difficulties. If the infant's breathing becomes irregular, the control system will notify the parent who will rush to assistance. If the soldier is wounded, the change in body temperature and heart rate will create a warning for the medics to come to his aid. Not only will the medics know there is a problem, but also a location system on the soldier will allow the medic to find the soldier quickly.

This kind of technology is also being transmitted to the world of sports. One of the obvious applications is for training purposes. Both the athlete and the trainer can observe changes in vital signs and determine the degree and efficiency of the workout. At Tampere University of Technology (Finland), researchers have made a snowmobile suit that includes a location sensor and transmitter as well as accelerometers to detect crashes. If a crash should occur, the suit will send a distress call that includes the location of the athlete as well as vital signs.

**Sources of power.** As exciting new applications of electronics in textiles develop, there is a need to provide electrical power to these devices. There are several interesting approaches in development that will see future applications.

A few companies have produced very thin and flexible batteries that are about as intrusive as a label. Although these don't provide very much power, they can be sufficient to handle electrochromic devices or even small fiber optics.

There are some interesting variations being developed other than batteries. One is a generator that is attached to shoes. A generator creates electrical energy by spinning a magnet through a coil of wire. This is the opposite of making a magnet by wrapping a wire around a nail and running electricity through the wire. The basic idea is to make the heel of the shoe able to move up and down so that with each step the wearer pushes the heel up, which moves magnets through a coil and electricity is generated. Then the shoe is simply connected to the garment to provide electricity. There are a few problems with this idea, such as the wires required to connect the shoe to the clothes, and the fact that the heel of the shoe might be larger than normal.

Electricity can also be converted from thermal energy through a process known as the Seebeck effect. In the Seebeck effect, two different conducting materials are joined, and when the temperature between them is different, an electric current is produced. This can be great for cold weather environments, where one conductor is on the outside of a coat, so it is cold, and the other conductor is on the inside by the wearer where it is warm. This difference in temperature can create electricity that can be used for various things, such as charging a cell phone or MP3 player, or finding one's coordinates through a global positioning system.

The opposite of the Seebeck effect is the Peltier effect, wherein electricity can be used to create temperature, but not like a heater, rather like a cooler. By proper choice of the conducting materials, the Peltier device can become cooler than the environment, allowing a flexible cooling system. Such devices can be embedded in fabrics.

Various companies have developed flexible solar cells. Solar cells convert light into electricity. The recent possibility to make them flexible allows them to be used in clothing and accessories. Recently a student of the author of this article, Lauren Sabia, developed a shoulder bag that incorporates flexible solar cells in the strap and has conducting wires that run to a cell phone holder allowing the solar cells to charge a cell phone when not in use.

### The Future

It is not known what the future holds for high-tech textiles. There may exist far-out concepts such as a tie made from fibers that are semiconductors allowing the garment to double as a memory storage device for a computer.

Perhaps yarns will be developed that have muscle-like behavior that allows them to contract, making the sleeves of a shirt give the wearer extra strength or speed. What is known, though, is that most technological advances eventually make their way into textile products because just about everybody wears clothing.

See also **Future of Fashion; High-Tech Fashion.**

### BIBLIOGRAPHY

Bolton, Andrew. *The Supermodern Wardrobe*. London: Victoria and Albert Museum, 2002.

Braddock, Sarah E., and Marie O'Mahony. *Techno Textiles: Revolutionary Fabrics for Fashion and Design*. London and New York: Thames and Hudson, Inc., 1999.

———. *Sportstech: Revolutionary Fabrics, Fashion, and Design*. London and New York: Thames and Hudson, Inc., 2002.

Christopher M. Pastore

**TEENAGE FASHION** Since World War II, clothing styles adopted by young people have been a powerful influence on the development of fashion in North America and Europe. The postwar growth of young people's spending power ensured that the youth market became a crucial sector of the fashion business. The styles adopted by young people, moreover, also became an important influence on wider fashion trends. Indeed, by the 1990s the "youth" market had expanded to embrace not only teenagers, but also consumers in their twenties, thirties, and older.

### "B'hoys" and "Scuttlers"

Distinctive fashions for young people were not unique to the twentieth century. During the Victorian era a gradual increase in young workers' leisure time and disposable income laid the basis for an embryonic youth market, with cities in America and Europe seeing the development of mass-produced goods, entertainments, and fashions targeted at the young.

Young people also used fashion to mark out individual and collective identities. During the 1890s, for example, many working girls in urban America rejected conservative modes of feminine dress in favor of gaudy colors, fancy accessories, and skirts and dresses cut to accentuate their hips and thighs. Young working men also adopted distinctive styles. In the mid-nineteenth century, for instance, the Bowery area of New York City was home to dandified street toughs known as "B'hoys." According to the socialite Abraham Dayton, "These 'B'hoys' ... were the most consummate dandies of the day," and paraded the streets with lavishly greased front locks, broad-brimmed hats, turned-down shirt collars, black frock-coats with skirts below the knee, embroidered shirts, and "a profusion of jewelry as varied and costly as the b'hoys could procure" (Dayton, pp. 217–218).



Comparable fashions also appeared in Europe. For instance, in his autobiographical account of life in the British town of Salford, Robert Roberts recalled the gangs of young toughs known as “scuttlers” who, at the turn of the century, sported a trademark style of “union shirt, bell-bottomed trousers, heavy leather belt picked out in fancy designs with a large steel buckle, and thick, iron-shod clogs” (Roberts, p. 155).

### Flappers and Campus Culture

The 1920s and 1930s saw the youth market expand further. In Britain, despite a general economic downturn, young workers’ disposable incomes gradually rose, and they were courted by a growing range of consumer industries. In the United States, the economic boom of the 1920s also ensured a budding youth market, while distinctive styles became increasingly associated with the young. The image of the young, female “flapper” was especially prominent. With her sleek fashions, short bobbed hair, and energetic leisure pursuits, the archetypal flapper featured in many advertising campaigns as the embodiment of chic modernity.

Clothing styles geared to young men also became more distinctive. From the 1890s sportswear became popular for casual attire. Shirt styles previously worn for sports replaced more formal garb as a new, leisure-oriented aesthetic surfaced within young men’s fashion. Indicative was the appearance of the “Arrow Man,” who became a fixture of advertisements for Arrow shirts from 1905 onward. A model of well-groomed and chisel-jawed masculinity, the “Arrow Man” was a youthful and stylish masculine archetype whose virile muscularity guaranteed a fashionability untainted by suspicions of effeminacy. With the expansion of American colleges and universities during the 1920s, an identifiable “collegiate” or “Ivy League” style of dress also took shape. Clothing firms such as Campus Leisure-wear (founded in 1922), together with the movie, magazine, and advertising industries, gave coherence to this smart-but-casual combination of button-down shirts, chino slacks, letter sweaters, cardigans, and loafers.

### Bobby Soxers and Teenagers

During the 1940s the economic pressures of wartime drew significant numbers of young people into the American workforce. As a consequence, youth enjoyed a greater measure of disposable income, with U.S. youngsters wielding a spending power of around \$750 million by 1944. This economic muscle prompted a further expansion of the consumer industries geared to youth. Young women emerged as a particularly important market, and during the 1940s the epithet “bobby-soxer” was coined to denote adolescent girls who sported a new style of sweaters, full skirts, and saddle shoes, and who jitterbugged to the sounds of big-band swing or swooned over show-business stars such as Mickey Rooney and Frank Sinatra.

The “teenager” was also a creation of the 1940s. Since the 1600s it had been common to refer to an ado-

lescent as being someone in their “teens,” yet it was only during the 1940s that the term “teenager” entered the popular vocabulary. The U.S. advertising and marketing industries were crucial in popularizing the concept. American marketers used the term “teenager” to denote what they saw as a new market of affluent, young consumers associated with leisure-oriented lifestyles. Eugene Gilbert made a particularly notable contribution. Gilbert launched his career as a specialist in youth marketing in 1945, and by 1947 his market research firm, Youth Marketing Co., was flourishing. Gilbert was acknowledged as an authority on the teenage market, and during the 1950s his book, *Advertising and Marketing to Young People* (1957), became a manual for teen merchandising.

The success of *Seventeen* magazine also testified to the growth of the American “teen” market. Conceived as a magazine for college girls, *Seventeen* was launched in 1944. By 1949 its monthly circulation had reached two and a half million, the magazine’s features and advertising helping to disseminate “teenage” tastes throughout America.

### The Teenage Market Explodes

During the 1950s the scope and scale of the U.S. youth market grew further. This was partly a consequence of demographic trends. A wartime increase in births and a postwar “baby boom” saw the American teen population grow from 10 million to 15 million during the 1950s, eventually hitting a peak of 20 million by 1970. A postwar expansion of education, meanwhile, further accentuated notions of youth as a distinct social group, with the proportion of American teenagers attending high school rising from 60 percent in the 1930s, to virtually 100 percent during the 1960s. The vital stimulus behind the growth of the youth market, however, was economic. Peacetime saw a decline in full-time youth employment, but a rise in youth spending was sustained by a combination of part-time work and parental allowances, some estimates suggesting that teenage Americans’ average weekly income rose from just over \$2 in 1944 to around \$10 by 1958 (Macdonald, p. 60).

During the 1950s, teen spending was concentrated in America’s affluent, white suburbs. In contrast, embedded racism and economic inequality ensured that African American and working-class youngsters were relatively marginal to the commercial youth market. Nevertheless, African American, Mexican American, and working-class youths generated their own styles that were a crucial influence on the wider universe of youth culture. During the 1930s, for example, young African Americans developed the zoot suit style of broad, draped jackets and pegged trousers that gradually filtered into mainstream fashion. During the 1950s, meanwhile, African American rhythm and blues records began to pick up a young, white audience. Reconfigured as “rock ’n’ roll” by major record companies, the music was pitched to a

mainstream market and became the soundtrack to 1950s youth culture.

The 1950s also saw work wear incorporated within youth style. Denim jeans, especially, became a stock item of teen fashion. During the 1860s Levi Strauss had patented the idea of putting rivets on the stress points of workmen's waist-high overalls commonly known as "jeans." By the 1940s jeans were considered leisure wear, but during the 1950s their specific association with youth culture was cemented after they were worn by young film stars such as James Dean and Marlon Brando, and by pop stars such as Elvis Presley. Levi Strauss remained a leading jeans manufacturer, but firms such as Lee Cooper and Wrangler also became famous for their own distinctive styles.

### Global Circulation of Teenage Fashion

The growth of the mass media was a crucial factor in the dissemination of teenage fashion. The proliferation of teen magazines, films, and TV music shows such as *American Bandstand* (syndicated on the ABC network from 1957), ensured that shifts in teen styles spread quickly throughout the United States. The global circulation of U.S. media also allowed the fashions of teenage America to spread worldwide. In Britain, for example, the zoot suit was adopted by London youths during the 1940s, the style subsequently evolving into the long, "draped" jackets that were the badge of 1950s toughs known as "Teddy boys." Behind the "iron curtain," too, youngsters were influenced by American fashion. In the Soviet Union, for example, the 1950s saw a style known as "*stil*" develop as a Russian interpretation of American teenage fashion.

As in the U.S., demographic shifts underpinned the growth of the European teen market. In Britain, for example, a postwar baby boom saw the number of people aged under twenty grow from three million in 1951 to over four million by 1966. An expansion of education also reinforced notions of young people as a discreet social group. As in America, economic trends were also vital. In Britain, for instance, buoyant levels of youth employment enhanced youth's disposable income, and market researchers such as Mark Abrams identified the rise of "distinctive teenage spending for distinctive teenage ends in a distinctive teenage world" (Abrams, p. 10). The teen market that emerged in postwar Britain, however, was more working-class in character than its American equivalent. In Britain increases in youth spending were concentrated among young workers, and Abrams estimated that "not far short of 90 percent of all teenage spending" was "conditioned by working class taste and values" (Abrams, p. 13).

European youth style fed back into the development of U.S. youth culture. During the mid-1960s, for example, America was captivated by a British pop music "invasion" spearheaded by the Beatles and the Rolling Stones. American women's fashion, meanwhile, was

transformed by British exports such as the miniskirt and Mary Quant's chic modernist designs. British menswear was also influential. Surveying the fashion scene in "Swinging London," for example, *Time* magazine was impressed by "the new, way-out fashion in young men's clothes" (*Time*, 15 April 1966). In autumn 1966 a flurry of media excitement also surrounded the arrival in America of British "Mod" style—a fusion of fitted shirts, sharply cut jackets, and tapered trousers, which was itself inspired by the smoothly tailored lines of Italian fashion.

### Counterculture, Race, and Teenage Style

The counterculture of the late 1960s and early 1970s had a major impact on international youth style. A loose coalition of young bohemians, students, and political radicals, the counterculture shared an interest in self-exploration, creativity, and alternative lifestyles. The counterculture's spiritual home was the Haight-Ashbury neighborhood of San Francisco, but films, magazines, and television, together with the success of rock bands such as Jefferson Airplane and the Grateful Dead, disseminated countercultural styles throughout the world. The nonconformity and exoticism of the counterculture leaked into mainstream youth style, and hip boutiques abounded with countercultural influences in the form of ethnic designs, psychedelic patterns, faded denim, and tie-dye.

The 1960s and 1970s also saw African American youngsters become a more prominent consumer group. A combination of civil rights activism and greater employment opportunities improved living standards for many African Americans and, as a consequence, black teenagers gradually emerged as a significant market. This was reflected in the soul music boom of the 1960s and the success of record labels such as Berry Gordy's Tamala-Motown empire. Soul also picked up a significant white audience, and the influence of African-American style on the wider universe of youth culture continued throughout the 1970s—first with the funk sounds pioneered by James Brown and George Clinton, and then with the eruption of the vibrant disco scene.

The late 1970s also saw the emergence of rap music and hip-hop culture (which combined graffiti, dance, and fashion). Hip-hop first took shape in New York's South Bronx, where performers such as Afrika Bambaataa and Grandmaster Flash combined pulsating soundscapes with deft wordplay. Hip-hop style was characterized by a passion for brand-name sportswear—trainers, tracksuits, and accessories produced by firms such as Adidas, Reebok, and Nike. Rap trio Run-DMC even paid homage to their favorite sports brand in their anthem "My Adidas." During the 1990s rap impresarios even launched their own hip-hop fashion labels. For example, in 1992 Russell Simmons (head of the Def Jam corporation) launched the Phat Farm sportswear range, while in 1998 Sean "Puffy" Combs (head of Bad Boy Records) launched the Sean John clothing line.

### The 1990s and Beyond

During the 1980s and 1990s, a rise in youth unemployment, coupled with the declining size of the Western youth population, threatened to undermine the growth of teen spending. By the beginning of the twenty-first century, however, demographic shifts and economic trends indicated that youth would continue to be a lucrative commercial market. Despite a long-term decline in Western birth rates, the youth population was set to increase during the new millennium as the “echo” of the “baby boom” worked its way through the demographic profiles of America and Europe. On both sides of the Atlantic, moreover, market research indicated that teenagers’ spending power was still growing.

Teenage fashions also increasingly appealed to other age groups. For example, manufacturers, retailers, and advertisers increasingly targeted teenage fashions at pre-teens (especially girls), who were encouraged to buy products ostensibly geared to older consumers. Teenage fashions also crept up the age scale. By the end of the 1990s, many consumers aged from their twenties to their forties and above were favoring tastes and lifestyles associated with youth culture. “Teenage fashion” therefore, was no longer the preserve of teenagers, but had won a much broader cultural appeal.

See also **Street Style; Subcultures.**

### BIBLIOGRAPHY

- Abrams, Mark. *The Teenage Consumer*. London: Press Exchange, 1959.
- Austin, Joe, and Michael Willard, eds. *Generations of Youth: Youth Cultures and History in Twentieth-Century America*. New York: New York University Press, 1998.
- Dayton, Abraham. *The Last Days of Knickerbocker Life in New York*. New York: G. P. Putnam’s Sons, 1897.
- Fass, Paula. *The Damned and the Beautiful: American Youth in the 1920s*. Oxford: Oxford University Press, 1978.
- Frank, Thomas. *The Conquest of Cool: Business Culture, Counter-culture, and the Rise of Hip Consumerism*. Chicago: University of Chicago Press, 1997.
- Fowler, David. *The First Teenagers: The Lifestyle of Young Wage-Earners in Interwar Britain*. London: Woburn, 1995.
- Gilbert, Eugene. *Advertising and Marketing to Young People*. New York: Printer’s Ink, 1957.
- Hollander, Stanley C., and Richard Germain. *Was There a Pepsi Generation Before Pepsi Discovered It? Youth-Based Segmentation in Marketing*. Chicago: American Marketing Association, 1993.
- Macdonald, Dwight. “A Caste, a Culture, a Market.” *New Yorker* (22 November 1958).
- Osgerby, Bill. *Youth in Britain Since 1945*. Oxford: Blackwell, 1998.
- Palladino, Grace. *Teenagers: An American History*. New York: Basic Books, 1996.
- Pilkington, Hilary. *Russia’s Youth and Its Culture: A Nation’s Constructors and Constructed*. London: Routledge, 1994.

Roberts, Robert. *The Classic Slum: Salford Life in the First Quarter Century*. Harmondsworth: Pelican, 1973.

Rollin, Lucy. *Twentieth Century Teen Culture by the Decades: A Reference Guide*. Westport, Conn.: Greenwood Press, 1999.

Bill Osgerby

**TENCEL.** See **Rayon.**

**TENNIS COSTUMES** The game of tennis or *Jeu de Paume* originated in France in the thirteenth century. It was played on an indoor court and became known as Real Tennis in Britain, Court Tennis in the United States, and Royal Tennis in Australia. No special clothes were worn by the nobility who played this game, although King Henry VIII, who was a keen player, preferred playing in a linen shirt and breeches. By the seventeenth century, a player is mentioned “cloathed all in white” (Cunnington and Mansfield, p. 86), the first reference to what was to become the standard color for the newer game of long, open, or lawn tennis, which was played outside.



**Bunny Austin with J. Asboth at Wimbledon.** During the 1930s, male tennis players faced a debate over whether it was appropriate for them to wear tennis shorts. Male players have seldom faced the controversy over attire that has at times embroiled their female counterparts. HULTON ARCHIVE/GETTY IMAGES. REPRODUCED BY PERMISSION.





**Venus Williams.** Sporting an outfit designed by Diane von Furstenburg, Venus Williams is not the first to wear designer attire on the tennis court. In 1949, Gussy Moran created controversy with an outfit she wore by designer Teddy Tinling. AP/WIDE WORLD PHOTOS. REPRODUCED BY PERMISSION.

### Lawn Tennis

There was a lull in the popularity of the game in the eighteenth century, but by the 1860s, lawn tennis was firmly established as a favorite sporting activity, particularly in Britain. In 1877, the All England Croquet and Lawn Tennis Club (AECLTC), the ruling body for the Wimbledon Championships, established the first Championship match, a Gentleman's Singles Event. There were no formal dress codes. Instead, the AECLTC relied on the unwritten rules of middle-class decorum. Men traditionally wore white flannels with long-sleeved white cotton shirts. However, for women, the fashions of the time made it difficult to find a practical alternative to the restrictive clothes of the period. "Lawn tennis shoes, black with India rubber soles" (Cunnington and Mansfield, p. 88) were helpful, but long narrow skirts with trains,

even those that could be tied back, hindered women from fully participating in the sport in an athletic way.

### Shorts and Skirts

By the beginning of the twentieth century, women were still playing in corsets with shirts buttoned to the neck and long ankle-length skirts. The arrival at Wimbledon in 1919 of Suzanne Lenglen from France changed forever the way women dressed on the tennis court. Lenglen wore a short-sleeved, calf-length, loose white cotton frock with white stockings and a floppy linen hat that she later replaced with her trademark bandeau. This style of dress, often made from white cotton pique but occasionally silk, influenced not just serious tennis players but was copied by young girls across the United Kingdom. However, as day-dress lengths grew longer in the 1930s, the divided skirt and then shorts became the norm for female players across the Western world taking the lead from American players. Men were also wearing shorts and short-sleeved shirts in the United States and France by the 1930s. Champion French player Rene Lacoste designed the first "polo" shirt in 1925 with his signature "crocodile" emblem chosen for his tenacity of play. Within a year, similar versions were available in London, made by Izod's of London's West End, who claimed they developed from golf shirts. British men were reluctant to wear shorts for competition tennis until after 1945. "Bunny" Austin was the only man to wear shorts on Wimbledon's Center Court in the 1930s. Although white was always the favored color, there were no regulations at Wimbledon about color until a 1948 restriction to discourage the increased use of colored trimmings on women's outfits. By 1963, the only items allowed to be not purely white at Wimbledon were a cardigan, pullover, or headwear. With the advent of sports manufacturers' sponsorship deals with top players, in 1995, Wimbledon restricted logos so that outfits were "almost entirely white" (Little, p. 305). Even away from Wimbledon, white remains the favored color.

### Naughty Knickers

In 1949, American Gussy Moran caused an uproar by wearing visibly lace-trimmed panties at Wimbledon under her short white tennis skirt. They had been designed for "Gorgeous" Gussy by British ex-tennis player turned designer Teddy Tinling for \$17 from an experimental rayon fabric. Tinling remained the key name in women's tennis-wear design for the next twenty years, styling dresses for most of the famous female names in tennis. Throughout the 1950s and 1960s, frilly panties were popular for female tennis players. But Moran was not the first to flash her panties on court:

Dainty garments trimmed with lace do not look quite appropriate for a strenuous game, and in these days when the game is played really hard, lady's undergarments often do not leave much to the imagination, therefore knickers made of silk stockingette seem to be quite the thing. (*Woman's Life*, 31 July 1924, p. 12)

Male modesty ruled on court in the 1930s, as evidenced in this quote from *New Health*:

Try even to wear "shorts" for tennis ... and every "right-minded" male on the courts will react with a resentful leer. The implication is that they would look like a lot of funny little boys. Yet ... no one feels like jeering when eleven hefty footballers run on to the field in "shorts." (*New Health*, May 1930)

British player and former Wimbledon champion Fred Perry developed a leading line of men's sportswear from the 1950s, focusing on the traditional tailored shorts and short-sleeved shirts for men. New fabric technologies, in particular breathable fabrics, have slowly revolutionized sportswear in general. One of the oldest, Aertex, was developed in the late nineteenth century by two British doctors, mainly for underwear. From the 1920s, it was being used to make men's tennis shirts. By the 1960s, synthetic fibers such as quick-drying polyester were replacing cotton. In the 1970s, the fashion of long hair for men meant that many copied their idol Bjorn Borg's signature headband, reminiscent of Suzanne Lenglen's bandeau. The 1980s was a decade of traditional styling for both men and women, with close-fitting short shorts being worn by men and wraparound skirts popular for female players. An exception was U.S. player Anne White who, in 1985, caused a sensation at Wimbledon by wearing a white catsuit. It was not a fashion that caught on. By the 1990s, men's tennis shorts became longer and looser, and shirts baggier. For women, however, the introduction of Lycra into tennis wear drew the focus away from their playing skills. Players with sponsorship deals, such as Serena Williams with sportswear firm Puma and Anna Kournikova with Adidas, promoted a body-clinging style light-years away from the corseted players of a hundred years before.

See also **Uniforms, Sports.**

#### BIBLIOGRAPHY

- Cunnington, Phillis, and Alan Mansfield. *English Costume for Sports and Outdoor Recreation from the 16th to the 19th Centuries*. London: Adam and Charles Black, 1969. Fascinating for the early period.
- Horwood, Catherine. "Dressing like a Champion: Women's Tennis Wear in Interwar England." In *The Englishness of English Dress*. Edited by Christopher Breward, Becky Conekin, and Caroline Cox. Oxford: Berg, 2002. Concentrates on the period up to 1939.
- . "Anyone for Tennis?: Male Modesty on the Tennis Courts of Interwar Britain." *Costume* 38 (2004): 101–106.
- Lee-Potter, Charlie. *Sportswear in Vogue Since 1910*. London: Thames and Hudson, Inc., 1984. Useful illustrations.
- Little, Alan. *Wimbledon Compendium 1999*. London: The All England Lawn Tennis and Croquet Club, 1999. Detailed listings.
- Schreier, Barbara A. "Sporting Wear." In *Men and Women: Dressing the Part*. Edited by Claudia Brush Kidwell and Va-

lerie Steele. Washington, D.C.: Smithsonian Institution Press, 1989. Section on tennis, pp. 112–116.

Catherine Horwood

**TERRYCLOTH.** See **Weave, Slack Tension.**

**TEXTILES, AFRICAN** For more than a thousand years, West Africa has been one of the world's great textile-producing regions. The yarn available locally for spinning was cotton, which grew in at least two colors, white and pale brown. In some places a wild silk was also spun, while raffia and bast fibers were available in addition, as were imported textiles and fibers from trans-Saharan and coastal trade networks, the latter from the late fifteenth century onward. Only in the inland Niger delta region of Mali were the wool fibers of local sheep of sufficient length to permit spinning, whereas north of the Sahara wool was the major source of spun yarn. Fragments of bast-fiber textile were recovered from the ninth-century site of Igbo-Ukwu in Nigeria, and cotton and woolen cloth from eleventh-century deposits in Mali, suggest traditions already well established. (Earlier archaeological textiles from Egypt and the Mahgreb are beyond the scope of this essay.) Elsewhere in the sub-Saharan region, in the forests of central Africa, raffia was the only available fiber, and in the savannas of east and southern Africa cotton was spun, at least as far south as Great Zimbabwe.

Throughout West Africa the most widely used dye was a locally produced indigo, also exported for use north of the Sahara, though in both regions other colors were available from vegetable and mineral sources. These dyestuffs might be used on the yarns prior to weaving, sometimes tie-dyed to form simple ikat-like patterns, and they were used in the coloring and patterning of woven cloth. In some areas woven textiles and tailored garments were embroidered, especially in the region from Lake Chad westward to the inland Niger delta of Mali. There was also some occurrence of patchwork, appliqué, and quilting; and one tradition of handprinted cloth. Handprinted cloth was also found in Zanzibar, brought from India. In the raffia-weaving region of central Africa, cut-pile embroidery was well developed together with appliqué and patchwork. In eastern and southern Africa, local textile traditions seem to have depended on the weaving process for patterning. From the late nineteenth century onward, local textile industries in sub-Saharan Africa have had to compete with factory-printed cotton cloth, sometimes successfully, though in eastern and southern Africa the local production of woven cloth was supplanted in the early twentieth century. The felting of vegetable fibers to produce bark cloth (strictly speaking not a textile) has survived in Ghana and Uganda, though it was at one time more widespread.

The mechanical basis for the interlacing of warps and wefts throughout pre-industrial handloom production in Africa takes one of two forms. The most widespread system consists in leashing one set of warps to a single heddle-rod, which is manipulated with the aid of a shed stick. This is the basis of the upright fixed heddle loom used by Berber women in north Africa for weaving the fabrics used in their clothing, and of the loom laid out on the ground through the Sahara and in northern Sudan for weaving tent cloth. In Nigeria and Cameroon, women used an upright version of it, manipulating both heddle and shed stick to weave cotton and other yarns. Except in the southern Igbo town of Akwete, however, it has recently largely given way to the double-heddle loom, yet to be described. In the Cross River region in southeast Nigeria, as throughout the central African forests, male weavers used a more-or-less upright single-heddle loom to weave raffia. In parts of northeast Nigeria, and seemingly across the savannas to east Africa and south to Zimbabwe, a horizontal version of this loom type, raised off the ground but with a fixed heddle, was used in weaving cotton textiles.

Throughout West Africa, from Senegal to Chad and from the sahel to the coastal region, the more commonplace loom type has both sets of warps leashed, each to one or other of a pair of heddles linked by means of a pulley suspended above the loom and with pedals worked by the feet below. The advantage is, of course, that both hands and feet are employed, enabling cloth to be woven with greater speed and efficiency than is possible using single-heddle equipment. This loom type is also used in Ethiopia and by Arab weavers in North Africa. However, in West Africa the loom itself, with which this double-heddle system is used, has two features particular to the region: the first is the dragstone with which the warp elements are held taut. The second is the narrowness of the web; for it continues to be both normal and commonplace for cloth to be woven in a long, narrow strip often no more than about 4 inches (10 cms) wide, although in some traditions the web may be broader, perhaps up to about 12 to 14 inches (30–35 cms) and cloth as narrow as a .5 inches (1.5 cms) is known. Once the desired length is complete, it will be cut into pieces and sewn together edge-to-edge. It is only then that any visual effects intended by the weaver can be seen, manifesting a specific arithmetic in the precise counting of warps and wefts, as well as in the geometry in the layout of pattern that weavers must learn, and learn how to develop, if a given tradition is to flourish.

The patterning obtained through the process of weaving in West Africa is most commonly of three or four kinds. The first is warp striping, achieved simply by laying the warps as close as possible in the preparation of the loom and using different colors. The same pattern of stripes can be repeated across the face of the cloth, or two or more sequences of stripes can be placed in sequence, and the visual effects can sometimes dazzle the

eyes as if the colors were dancing. The second means of patterning depends upon spreading the warp elements apart as the loom is set up so that, in the woven cloth, the warps are hidden by the weft. For in allowing the weft to be seen, it becomes possible to create blocks of color that can be aligned across the cloth, or alternated to produce a chessboard-type effect, or so placed as to create a seemingly random scattering of color. A third type of woven pattern involves an additional or supplementary weft that floats across the warps. This is either floated across each face, or is woven in with the ground weft when not required for the design.

In West Africa, particular ethnic and/or regional traditions are characterized by specific ways of using these techniques. Warp stripes are still the most commonplace throughout the region, sometimes with supplementary floating weft patterns. One of the best examples of this is the Yoruba cloth known as *aso oke*, literally “top-of-the-hill cloth,” the hill identified as the location of the tradition received from one’s ancestors, and woven in the major weaving households of Nigerian cities such as Ilorin, Oyo Iseyin, and Ibadan. Yoruba weavers also weave openwork. Since the 1970s young women in Yoruba weaving households have taken up the double-heddle technology and have established themselves as independent weaving masters with great success in places where hitherto the upright loom was the sole apparatus, with the further result of inducing its obsolescence. Weft-faced patterns are especially located in Sierra Leone and in Mali, where it has sometimes been used as a picture-making process. In both countries warp-faced and weft-faced traditions flourish side by side. Only two traditions, Asante and Ewe, both in Ghana, bring all three weave structures together in one strip of fabric, thereby creating forms that are impossible to replicate exactly on a European broadloom. (It has been tried.) The narrower loom facilitates these design processes by allowing very different patterns to be placed beside each other in the one cloth. This may in the end be the justification for the continuing flourishing of these traditions. The use of supplementary warps is rare, but is beginning to be popular with some Ewe weavers. Asante and Ewe weaving is popularly known as *kente*, and while not a word with any obvious etymological significance, it may be derived from the Ewe verbs that refer to the processes of opening up the warp and beating in the weft.

Most North African weaving, whichever type of loom is used, tends to be weft-faced, and one can see this in textiles for clothing and in carpets. Tent cloths, however, are mostly warp-striped. In Somalia, locally woven cloth is generally a balanced plain weave that encourages plaid-like patterning, with stripes in both warp and weft. Weft-float patterns are a feature of some Ethiopian weaving, together with tablet-woven patterns of extraordinary complexity. In the raffia traditions of central Africa, cut-pile is the best-known means of patterning a cloth, but this is not part of the weaving process. In the cotton-



weaving traditions of east and southern Africa, the few surviving examples suggest that patterning was no more than stripes making use of the naturally different colors of local cotton.

Africa is a complex social and historical entity. There are many histories in which the traditions of a given locality have become engaged with forms and fabrics introduced from elsewhere in the formation of local modernities now taken for granted. This occurred in the Middle East, Europe, and Africa; there is more on this to follow. There are continuities of form, practice, and ideas from one place to another, especially seen in the delight in breaking up an otherwise plain surface. In principle, there is nothing specifically African about this, of course, but there are specifically African forms of its manifestation. It also happens that some of these specificities depend upon a particular inheritance of the technical means available locally for the manufacture of a piece of cloth. The delight in breaking up an otherwise plain surface manifested in hand-woven patterns, in a thousand different ways, especially in West Africa, is also seen in the techniques of resist-dyeing. In the western Yoruba city of Abeokuta founded in the 1830s, two forms of the indigo-dyed cloths known as *adire* developed with the advent of factory-woven cotton shirting. In one, raffia fiber was used to stitch or tie a pattern across the whole length and breadth of the cloth, while the other was made by pasting starch in a repeat pattern through cut-metal stencils. The raffia and the starch, each in its own way, would resist the dye to create the patterned surface. The manner in which the patterns developed was conditioned by the quality of the factory-woven fabric which was finer in texture than a textile locally woven of hand-spun cotton. Moreover, although indigo-dyed yarn was a commonplace element in weaving, locally woven cloths would normally only have been resist-dyed if they were old and worn and in need of toughening up for continued use. Then a few sticks or stones might have been stitched into the cloth, providing the original basis of the raffia-tied *adire*. The starch-pasted method almost certainly was adapted from European packaging; the zinc linings of colonial tea chests provided the original source of the metal for the stencils. In another Yoruba city, Ibadan, also founded in the 1830s, rather than use cut-metal stencils, comparable designs were painted free-hand, again using the starch. There is also now some suggestion that while the imperative to pattern, and the raffia-resist method, has its origins in local sensibilities and practices, at least some aspects of these developments were influenced by ideas and/or practices brought to Nigeria by freed slaves repatriated from Sierra Leone. In any case, much of the early imagery of the starch-resist designs can be derived from topical events in colonial history.

Long-running trade and family contacts between Lagos and Freetown may also have provided the route whereby a new set of resist-dyeing techniques arrived in

Nigeria in the late 1960s. They quickly became known as *kampala*, so named after a well-reported peace conference in that Ugandan city. *Kampala* techniques include folding and tying, and stitching, the use of melted candle wax as a resist agent, and the use of factory-made dyes. These and other techniques are indeed found in Freetown, but also in Bamako in Mali, St. Louis in Senegal, and indeed all over West Africa. Meanwhile, the popularity of *Kampala* signaled the decline of *adire* in Nigeria. There has been a limited revival, mainly through the work of textiles artist Nike Olaniyi at her art center in Oshogbo; but otherwise the resist-dyed patterning using the technology identified in Nigeria as *kampala* flourishes throughout West Africa, even as Yoruba *adire* remains at best obsolescent. Mali is also the location of the Bamana technique known as *bogolan*. This is a method of dyeing the cloth yellow, painting designs in iron-rich earth to darken the dye, and bleaching out the yellow in the unpainted areas. Originally for the magical protection of young women as they are initiated into adult status, and of hunters, this technique has evolved in recent years to provide a modern fashion fabric in Mali and widely available and imitated in Europe and the United States, and also a means of current picture making.

With so much variety in local traditions, we might ask why traders found a ready market for the cloths they brought with them; and yet we know that from the very first records of trans-Saharan trade, textiles were proceeding in both directions. The desirability of cloth, locally made and imported from elsewhere, was thus a well-established West African preference long before coastal trade with Europe, and the merchants must have known this from information available to them via North African sources. European traders from the outset of coastal trade had always included linen and woollen cloth amongst their goods. Some, in particular the Portuguese, traded local textiles from one part of the West African coast to another. They also captured slaves who were weavers and put them to work on the Cape Verde Islands making cloth with North Africa designs for the coastal trade. On the other hand, Danish merchants in the early eighteenth century were surprised to discover that Asante weavers unraveled the silk cloths they had obtained from them in order to reweave the yarn to local design specifications. Their shininess and well-saturated colors, though quite different to anything available locally, were perceived as effective within a local aesthetic. The local wild silk produced a less shiny grayish yarn, that was prestigious in some traditions but not in others. With local cotton and indigo together with other dyes, various shades of blue, yellow, green, brown, black, and a weak purplish pink were produced. A well-saturated red was not available, however; and yet red was almost everywhere a color of ritual value, though the precise content of that value was always locally specific. The color might have to do with transition from one condition of social existence to another, it could denote the volatile nature

of a deity, or have wide-ranging connotations from success in childbirth to bloodshed in war. As soon as red woolen cloth and cotton yarn were available they were in demand. Similarly in the nineteenth century, the waste from Italian magenta-dyed silk weaving was traded across the Sahara to be re-spun for local weaving.

In the late nineteenth century, silk was replaced by rayon and in due course by other artificial fibers, while ready-dyed cotton yarn assumed a substantial place in colonial trading accounts. The greater intensity and variety of color with modern dyes was one advantage, while the finer quality of machine-spun yarn was another. In a part of the world where conspicuous consumption was particularly manifested in the cloth you wore, in a context of increased demand given the democratization of systems of authority in colonial and post-colonial histories, the fact that machine-spun yarn could be woven faster than hand-spun cotton gave it an obvious advantage. The catalog of available textures was thus impressive: hand-spun cotton, machine-spun cotton, wild silk, imported silk (and its successors); and from the 1970s onward a laminated plastic fiber with a metallic core in all colors of the rainbow and more.

We can see this same design aesthetic in the bright, almost blatant, African-print fabrics now so ubiquitous throughout Africa, Europe, and the Americas. Indeed, this is a proposition that is supported by what we know of their history. In the course of the nineteenth century, Dutch textile manufacturers wanted to find a way of replicating the Indonesian wax batik process, to produce the textiles at a cheaper price, thereby undercutting Indonesian production. In due course, they developed a duplex roller system that printed hot resin on both faces of the cloth in the manner of the wax used in Indonesia (hence the term “waxprint”). The resin resisted the indigo, and once cleaned off, allowed for the hand-blocking of additional colors. However, two unintended developments in this process rendered the designs unacceptable in Indonesia: an inability to clean all the resin off, leaving spots that continued to resist the additional colors, together with the way these additional colors were not an exact fit but overlapped with adjacent parts of the design. These essentially technical problems imparted to the cloths a variegated quality that Indonesians did not like; and yet, when, by chance, Dutch merchants, probably in Elmina (the precise details remain unknown), tried these fabrics on their customers they proved to be extremely popular. Once the sights of the designers in the Netherlands were trained upon this region of West Africa, they quickly learned that the visualization of local proverbs added to the local interest in these fabrics. The earliest dated example, is located in the archive of the ABC (Arnold Brunnschweiler and Co.) factory at Hyde, Cheshire, though it was produced by the Haarlem Cotton Company, is 1895. It shows the palm of the hand with the twelve pennies of the English shilling: “the palm of the hand is sweeter than the back of the hand,” the point be-

ing that as the palm holds the money so we hope to receive good fortune.

In the preindustrial technologies of Africa, printed textiles were unknown but for the two examples of *adinkra* and *kanga*. The former is an Asante cotton cloth produced at Ntonso, north of Kumasi, in which graphic signs are printed in black, using stamps made from carved calabash (gourd). Almost all of the individual patterns have an associated proverb, but this has not prevented the appearance of novel patterns based on the Mercedes-Benz logo, or making use of writing. These cloths do not convey precise messages, but evoke a tradition of knowledge about the social world. When the designs are printed on red, black, brown, or purple, *adinkra* is worn at funerals, whereas on white it has celebratory implications. In Zanzibar and related centers of East African Swahili-speaking coastal visual practice the tradition of the *kanga*, developed from a hand-block-printing tradition brought from India. A length of cloth about one by two yards was printed in a variegated pattern with a differently patterned border that became identified by the Swahili word for guinea fowl due to its speckled plumage. Once these fabrics began to be factory-printed in India and East Africa, Swahili proverbs and political slogans found their way into these cloths with the development of designs that visualized the printed words. In both East and West Africa, variegated design and the visualization of proverbs seem to have been the keys to the success of cloths now designed and printed in substantial quantities in local factories.

See also **Adinkra; Adire; Bark Cloth; Bogolan; Indigo; Kanga; Kente; Loom.**

#### BIBLIOGRAPHY

- Barbican Art Gallery [John Picton et al]. *The Art of African Textiles: Technology, Tradition and Lurex*. London: Lund Humphries, 1995.
- Bolland, Rita. *Tellem Textiles: Archaeological Finds from Burial Caves in Mali's Bandiagara Cliff*. Leiden, Netherlands: Rijksmuseum voor Volkenkunde, 1991.
- Byfield, Judith. *The Bluest Hands, A Social and Economic History of Women Dyers in Abeokuta*. Oxford: James Currey, 2002.
- Clarke, Duncan. *The Art of African Textiles*. London: Grange Books, 1997.
- Gardi, Bernhard. *Le Boubou—C'est Chic*. Basel: Museum der Kulturen, 2000.
- Idiens Dale, and K. G. Ponting, eds. *Textiles of Africa*. Bath, U.K.: Pasold Institute, 1980.
- Kreamer, Christine Mullen, and Sarah Fee. *Objects as Envoys: Cloth Imagery and Diplomacy in Madagascar*. Seattle and London: National Museum of African Art, University of Washington Press, 2002.
- Lamb, Venice. *West African Weaving*. London: Duckworth, 1975.
- Lamb, Venice, and Judy Holmes. *Nigerian Weaving*. Hertingfordbury, U.K.: Roxford Books, 1980.
- Lamb, Venice, and Alastair Lamb. *Au Cameroun: Weaving—Tissage*. Hertingfordbury: Roxford Books, 1981.

- . *Sierra Leone Weaving*. Hertingfordbury: Roxford Books, 1984.
- Menzel, Brigitte. *Textilien aus Westafrika*. 3 vols. Berlin: Museums für Volkerkunde, 1972.
- Picton, John, and John Mack. *African Textiles*, 2nd ed. London: British Museum, 1989.
- Prince Claus Fund, 1998: *The Art of African Fashion*, Prince Claus Fund, The Hague, and Africa World Press, Asmara and Trenton, N.J. Note especially Hudita Nura Mustafa's "Sartorial ecumenes: African styles in a social and economic context," pp. 15–45.
- Renne, Elisha. *Cloth that Does Not Die: The Meaning of Cloth in Bunu Social Life*. Seattle and London: University of Washington Press, 1995.
- Ross, Doran. *Wrapped in Pride*. Los Angeles: University of California, 1998.
- Rovine, Victoria. *Bogolan: Shaping Culture through Cloth in Contemporary Mali*. Washington, D.C.: Smithsonian Institution Press, 2001.
- Sieber, Roy, John Picton, Rita Bolland, et al. *History, Design, and Craft in West African Strip-Woven Cloth*. Washington, D.C.: Smithsonian Institution, 1992.
- Spring, Christopher, and Julie Hudson. *North African Textiles*, British Museum, 1995.
- Tulloch, Carol, ed. *Black Style*. London: Victoria and Albert Museum, 2004. Note especially John Picton's "What to wear in West Africa," pp. 18–46.

John Picton

**TEXTILES, ANDEAN** Perhaps no other society in history poured as much cultural energy into textiles as indigenous Andean civilization. Galvanized by inhospitable terrain—soaring mountain ranges, impenetrable jungles, dry deserts, and cold oceans—Andean people achieved great technological accomplishment, economic prosperity, and political cohesion without written language. Textiles developed as the primary material focus of civilization, serving to embody wealth, communicate complex ideas, and conceptualize abstractions, as well as more familiar roles of personal identity in a fashion system. For Andean societies, the textile medium paralleled uses of gold, writing, mathematics, and painted art in European history. Meaning was conveyed not just in color, pattern, and style, but also through complex processes of weaving and fabric structures. The centrality of fiber art to the Andean mind resulted in a remarkable development of skills, design, and technique unmatched anywhere.

### Clothing in the Ancient Andes

Andean textile art flowered long before the sixteenth-century European invasion. Dry coastal deserts were home to third-millennium B.C.E. cotton traditions based on ingenious structural elaboration rather than color to achieve design. At the same time, mountain societies developed traditions of working colorful dyed camelid

fibers. Climate conditions leave few examples of highland wool traditions until brightly colored yarns appear on the coast during the first millennium B.C.E. The fusion of the two traditions established the character and brilliance of the Andean textile tradition that has persisted into the twenty-first-century.

Andean textile evidence comes from tombs in the coastal deserts with ideal preservation conditions. While opulent tombs may yield spectacular textiles, reconstruction of ordinary costume from grave goods demands care. Garments buried with important persons may reveal technical and design sophistication but not represent daily clothing. Less elaborate tombs, miniatures, and human images in tapestry or painted pottery show that a basic Andean costume existed by at least the first millennium B.C.E. and persisted until the arrival of Europeans two thousand years later. Constructed of short warp fabrics with little or no tailoring, the costume varied in pattern, layout, color, and structure to reflect cultural identity.

Across most of the Andean area, men wore a breechclout and a pullover shirt. The shirt extended nearly to the knee in some cultures but in others stopped at the waist, making the breechclout visible. Shirts might have a fringe at the bottom and arm openings, ornamental bindings, or other elaborate decoration that indicated social roles. A Nazca culture shirt of the late first millennium B.C.E. might be plain-woven natural-colored cotton embellished by complex wool embroidery at the neck slit, arm openings, and hem. The Middle Horizon Wari culture (500–1100 C.E.) made fine-spun alpaca tapestry shirts as symbols of rank and authority that conveyed complex patterned meanings. Men wore a mantle as an overgarment, carried a shoulder bag, and used a head-dress to express cultural identity. Headdresses included hats, turbans, and braided cords wound around the heads. Elaborate tapestry shirts of Wari men were complemented by a four-sided pile or knotted hat that expressed mythological themes.



### FABULOUS TOMBS

The dry deserts of coastal Peru hold elaborate tombs filled with fabric treasures demonstrating technical and design control over the textile medium, but not necessarily reflecting daily costume. Mummy bundles from Paracas (first millennium B.C.E.) contain huge wrapping cloths, fine decorated bands, and embroideries proving a keen understanding of mathematics as well as design. Patterns on cloth found in these bundles chronicle a rich spiritual life filled with mythical beings and elaborate rituals in a highly-stratified society.



The basic women's garment in pre-Columbian societies was a square cloth wrapped around the body below the arms and pinned or stitched above the shoulders. The dress reached below the knee and may have had plain color or more elaborate patterned stripes worn horizontally. Many cultures added a patterned belt. For cultures like Nazca, large shoulder pins were part of the fashion statement. Over the dress, Andean women wore a square or rectangular shawl around the shoulders and pinned at the breast. Highly visible shawls often had complex patterning in tapestry, embroidery, or warp-faced techniques. Like men, women wore culturally specific headdresses, such as woven headbands or head cloths that fell down the shoulders and back. Hair, generally worn long and loose, or in multibraided styles, also figured in statements of fashion and identity.

### The Inca Period

At the time of the sixteenth-century European invasion, the Inca Empire spanned highland and coastal Andes from present-day Colombia to Chile and united many ethnic and language groups into a single political and economic structure. Local costume from the basic Andean style of shirts and mantles, dresses and shawls, was preserved as an indicator of ethnic identity, useful in administration of the sprawling Inca enterprise. Evidence for Inca costume includes burials, figurines, and painted images found in earlier times, but also writings, line drawings, and portraits by early European visitors. Inca use of cloth may provide a good model for understanding costume and fashion in earlier Andean cultures.

Two modes of production characterized Inca textiles. *Qompi* was fine camelid cloth, mostly of tapestry, produced with state support by cloistered women or men. They worked on an unusual frame loom at least twice as wide as it was tall. The fabrics were folded in the middle to become men's shirts that were distributed by the government as uniforms or rewards for state service. Large checkerboard patterns and other repeating designs indicated social or military roles, while more elaborate registered patterns called *tokapu* may have functioned within a still obscure system of communication. *Tokapu* blocks are also found on belts used by both Inca men and women. *Awasqa*, a second mode of textile production made in the rural villages, was warp-faced cloth with complex patterns made from two oppositely colored warps in a technique known as complimentary warp weaving. Some *Awasqa* was tax payment to the state, but most local style cloth stayed within the village-specific fashion system.

People of all ranks within the Inca Empire probably wore the same essential costume of shirts, breechcloths, and mantles for men and wraparound dresses and shawls for women, with marked differences in quality to indicate class or identity. Finely spun and brightly colored cloth reserved for the Inca nobility was called silk by the Spanish because such smooth, lustrous, and fine-to-the-

touch fabric was only known in Europe from Chinese cloth. These fabrics became shirts that reached to the knee and were sometimes belted over a breechclout with a relatively plain mantle as outer garment. Inca men wore very short hair, and the upper classes used large earplugs that stretched the lobes. Men's headdress was rigidly controlled; higher classes wrapped ornate braided strands around their heads. Inca-period women's dress often had broad horizontal stripes and reached the ground, held at the waist with a highly patterned belt. The shawl pinned in front usually had more elaborate patterning in bands of complementary warp or weft weaves. Women's hair was loose or in two braids, and held by a patterned headband or covered with a cloth. Wrapped in striped and patterned cloth, Inca nobility must have made a very colorful sight indeed. People of lower status wore the same garment types, but they were constructed of coarser natural-colored yarns with less patterning laid out in village-specific formats.

### The Colonial Period

The European invasion of the sixteenth century altered costume drastically, and introduced new materials such as sheep's wool and silk, as well as new ideas and forms. In less than a hundred years, Andean men adopted European breeches, hose, and felt hats. The Inca tapestry shirt became ritual costume used to claim royal descent, and specific meaning of patterns was lost. Portraits of Inca noblewomen show fuller, ground-length Inca-style dresses. Decorated belts define the waist, and highly patterned shawls cover the shoulders. Common people of the Andes continued to use much of the basic costume but added pants for men and hats in the new European technique of knitting.

Spanish Peru, a closed colony until the eighteenth century, developed a unique Creole costume from European, Islamic, and indigenous sources. In addition to the long full skirts and lace trim familiar in Europe, Spanish Creole women added the *manta*, a small hood that could cover the face in the manner of the Islamic Moors, and the *saya*, a long straight overskirt from indigenous Andean models. The *Limeña Tapada* (Covered Woman of Lima) of the seventeenth century wore long skirts to obscure the feet, while tight bodices went so far as to reveal the breasts in public.

The eighteenth-century advent of the Bourbon Kings in Spain and political ferment in Peru led to profound changes in the clothing and fashion. With the colony opened to trade, Creole costume fell into step with European fashion. Meanwhile, leaders claiming Inca royal descent revitalized indigenous costume as part of rebellion against Spanish authorities. Insurrections led to prohibition against indigenous costume and to sumptuary laws requiring Andeans to adopt a new costume derived from that of Iberian commoners. This set of clothes included vests, jackets, and knee-length breeches for men and full skirts for women. Both genders adopted a saucer-shaped hat



### GLOSSARY OF TECHNICAL TERMS

**Bayeta:** Fabric originally manufactured in Spain that was widely used in South America in the Colonial period. Made from cotton or wool fiber, it was loosely woven from softly twisted yarns that were brushed up on the surface. In order to make the fabric more compact and dense it was subjected to a special finishing process.

**Complementary warp pattern:** A pattern in which an additional set of lengthwise (warp) yarns is used in the same way as the primary set of warp yarns. Emery

(The Primary Structures of Fabrics, 1980) describes such warps as “co-equal.”

**Warp:** Lengthwise yarns in a woven fabric.

**Warp-faced:** Fabric in which the lengthwise (warp) yarns predominate on the surface of the fabric.

**Weft:** Crosswise yarns in a woven fabric. Synonyms include filling and woof.

**Weft-faced:** Fabric in which the crosswise (weft) yarns predominate on the surface of the fabric.

made of felt over an armature of coiled basketry. Widespread throughout the Peruvian Andes by the beginning of the nineteenth century, these costumes were precursors of the twenty-first century’s traditional Andean costume.

#### The Late Twentieth and Early Twenty-First Centuries

The multicultural Andes in 2004 encompasses parts of Ecuador, Peru, Bolivia, Chile, and Argentina, where nearly 30 million people speak indigenous languages. Millions more without language identity still live fundamentally Andean lives, with cultural identities reflected through widely-differing costume. Many use style flexibly, changing costume to express different aspects of the multiple identities that are their heritage.

The most elaborately-patterned handwoven Andean cloth is made in rural villages from Cuzco south through Bolivia. Each village has a distinctive costume derived from fusion of Iberian and indigenous Andean models. Many village women wear full skirts of balanced, plain-weave, woolen cloth known as *bayeta*, white cotton blouses and vests with machine embroidery, and felt or *bayeta* jackets. Village-specific felt-covered basket hats and decorated warp-faced shawls indicate identity. Some Bolivian women use a patterned straight *aksu* overskirt derived from the original Andean dress.

The distinctive costumes of women who leave village identity behind to live in major highland cities, use manufactured goods to declare participation in the money economy and class, rather than village identity. Knee-length pleated skirts with machine-made sweaters and blouses mimic but are not confused with rural costume. Women wear shoes and hose rolled at the knee, and cover their shoulders with machine-made shawls. High-crowned white straw hats are the most distinctive feature of the area-wide costume worn by women of commerce.

Highland men may own village-specific clothes for special occasions, but usually wear an area-wide costume to indicate class rather than village identity. Most costume elements are store bought, such as pants and shirts, although men use a poncho handmade by women in their lives. In the twentieth century throughout most of Peru and Bolivia, this poncho was walnut-dyed brown without pattern, but red ponchos with supplementary warp-woven patterns have more recently become popular with university-educated men. Brown ponchos are usually worn with a felt fedora, while red-poncho men prefer to go hatless with a neck scarf in very cold conditions.

The northern Andes of Ecuador has very different costumes, mostly made by specialists from machine-made cloth. Women wear dark wraparound skirts at the knee or below and cotton lace blouses topped with voluminous bead necklaces. Felt fedoras crown the head. Men wear shirts and pants of white cotton covered with a machine-made or handmade poncho that may be reversible or even have a collar but has little patterning. The belt that both sexes wrap around the waist may be the last remaining handwoven costume item.

The arrival of the money economy, tourism, and the information age has brought great change to traditional Andean costume. While some villages adhere to traditional productive patterns and costume norms, even rural people adopt conventional store-bought clothes as they enter the money economy. Many discover the warmth and convenience of down coats and other garments left by hikers and tourists. With even the most remote villages now within reach of television, many women abandon braided hairstyles of previous generations and adopt jogging suits and other casual dress. For thousands of years, technology of cloth production and use has been both a visible fashion statement and the primary mode of intellectual exploration. Recent changes challenge the

fundamental identity of Andean people, whose culture was built on cloth.

See also **America, South: History of Dress.**

#### BIBLIOGRAPHY

- Adelson, Laurie and Bruce Takami. *Weaving Traditions of Highland Bolivia*. Los Angeles: Craft and Folk Art Museum, 1979. Excellent photos of village specific cloth and costume from Bolivia.
- Guaman Poma de Ayala, Felipe. *Nueva Corónica y Buen Gobierno*. Paris: Université de Paris, Travaux et Mémoires de l'Institut d'Ethnologie XXIII, 1936. Over a thousand drawings of Inca life, costume, and history sent to the King of Spain in 1615.
- Murra, John V. "Cloth and Its Function in the Inca State." *American Anthropologist* 64, no. 4 (August 1962): 710–728. A fundamental account of the expanded use of cloth by Andean society.
- Paul, Anne. *Paracas Ritual Attire*. Norman: University of Oklahoma Press, 1990. An excellent analysis of textiles and costume found in sumptuous burials from the Paracas peninsula.
- Rowe, Ann Pollard, ed. "Nazca Figurines and Costume." *Textile Museum Journal* 29 and 30 (1991): 93–128. An excellent reconstruction of costume in ancient Peru.
- . "Inca Weaving and Costume." *Textile Museum Journal* 34 and 35 (1996): 5–53. An authoritative account of what people looked like during the Inca period.
- . *Costume and Identity in Highland Ecuador*. Seattle: University of Washington Press, 1998. An excellent and comprehensive examination of the costume used in the many cultural areas of Ecuador at the end of the twentieth century.
- Rowe, Ann Pollard, and John Cohen. *Hidden Threads of Peru: Q'ero Textiles*. London: Merrell, 2002. An exceptional view of cloth and culture in a contemporary Andean community.

*Ed Franquemont*

**TEXTILES, BYZANTINE** Constantine the Great (r. 324–337) reunified the Roman Empire as its sole ruler in 324 and promptly began the expansion of the little harbor city of Byzantium on the Bosphorus, renaming it Constantinople. Replacing Rome as the imperial capital, the city reflected the emperor's new Christian faith in the central cathedral complex, while Hellenistic and Eastern schemes were used in the city's public areas. The Byzantine Empire's vast, all-Mediterranean territory was greatly reduced after Justinian (527–565). It was beset by many reverses and crises throughout the flowering of the Macedonian dynasty (867–1056) and suffered its most brutal shock during the Sack of Constantinople by the Crusaders in 1204. Throughout the period Constantinople exerted a cultural, a spiritual, and at times, a military authority on its western and eastern neighbors, an influence that was reestablished during the Palaiologan dynasty (1261–1453). Byzantine art and architecture survived the empire's fall in 1453 to the Ottoman Turks by continuing in the Eastern Orthodox heritage.

#### The Textile Context

A Spanish rabbi and traveler, Benjamin of Tudela (1127–1173), reported on a visit to Constantinople that, "All the people look like princes. The Second Rome is a glittering city of miracles. Everybody is dressed in silk, purple and gold" (Geijer, p. 129). Such awe was a frequent reaction in Western visitors when encountering the splendor of the capital; they were also hopeful to be on the receiving end for imperial favors. These might take the form of superb Byzantine textiles, exceptional gifts of prestige and diplomacy for select secular or ecclesiastical rulers. Many of these silken achievements of superior loom technology and dyeing excellence survive in the early 2000s, often reduced to tiny fragments in church treasuries and museums. Patterned and figured, monochrome or multihued, these silks were made into vestments for powerful bishops and abbots, served as wrappers or purses for relics, and were draped, as large *pallia*, over the remains of saints in shrines and tombs. Rare imperial inscribed silks are known to have been stored in the west for decades or centuries before being used as funerary textiles. Silks from the imperial workshops and city guilds also came west in the trousseaus of Byzantine princesses. Yet others were silks of lesser quality, some made in the Islamic East, and purchased by Western visitors to Constantinople.

Europeans were probably unaware that an important reason for the strict ceremony of the imperial court in Constantinople was a long-standing game of one-upmanship vis-à-vis the equally elaborate etiquette in the courts of Middle East, and, from the late seventh century, Islamic rulers. Intricate court ceremony had a long history in ideas of divine kingship. Prior to Islam's introduction, the Byzantines had established relationships of reciprocity in peacetime as well as war with the Sasanian dynasty (224–651), by sharing designs, motifs, and figures. The first Islamic rulers of the Umayyad Caliphate (661–750) attempted to match the opulence of Byzantium in the architecture and decoration of their desert palaces. The Abbasid Caliphs (763–1258), settling in Baghdad, provided further rivalry to Constantinople in conspicuous consumption; late eighth-century texts describe how Syria's merchant fleet supplied luxury items to the Byzantine court. These interdependencies explain the numerous shared features in the art and architecture of the Mediterranean cultures, as well as the staying power of certain recurring motifs. After 1453, Byzantine style survived and continued, especially in embroidered panels used in the sacred and secular life of Greece, Armenia, Bulgaria, and in the monasteries of Kievan Rus.

#### Silk Manufacture and Importation

The 912 *Book of Ceremonies* of Constantine VII (d. 959) sets out the elaborate, ranked dress requirements for courtiers and administrators of the empire. To meet these prodigious needs, textile production was prioritized and put under imperial control. The first generation of skilled



weavers had been brought during the sixth century from the Mediterranean or Persia, where the draw-loom pattern device had developed since the third century. This technology allowed figured motifs to be mechanically replicated. The weavers' privileged position was hereditary to begin with, but later the conditions worsened as the state attempted to maintain control of the market forces. Texts such as the *Book of the Prefect (Eparchikon Bibliion)*, in which the regulations for the city's five private guilds were codified, details the organization of textile manufacture in Constantinople. There were merchants (*metaxoprates*, raw-silk dealers; *bestioprates*, silk-cloth vendors; and *prandioprates*, Syrian silk sellers) and manufacturers (*katartarii*, silk-thread producers; and *serikarii*, weavers).

Specialized trades of dyers of purple, weavers, and tailors worked in the imperial workshops, but information about the actual operations or types of equipment can only be inferred from the few surviving examples that can be securely identified. One striking feature of the finest silk *pallia* with their large-scale designs and multiple colors is the loom width. Some were more than 6 feet (2 meters) wide, requiring extraordinary technical capability in loom construction and accomplished levels of collaboration during the weaving. Silks from production centers outside the Empire do not match these dimensions; the widest from Zandaneh, near Bukhara, measured 47 inches (120 centimeters).

The Abbasid silk fabrics, imported in significant quantities to Constantinople by Syrian traders, indicate a range in weaving quality—the Byzantine wealthy may well have been dressed in imported Syrian silks, while true *panni imperialis* were reserved for the court. A surviving group of red-ground textiles, the so-called Samson silks, shows a standing man wrestling a lion framed by undulating borders; it is proof of the merchants' ability to provide an efficient supply chain for various markets. Details in the drawing of the figure and the execution vary from one example to the next, giving a range of quality for a popular theme from fine and perfectly woven to coarse and replete with weaving errors.

Rabbi Benjamin mentioned in his eleventh-century report that 2,500 Jews worked as dyers in Byzantine Pera, and 2,000 more in Thebes on Peleponnesos, evidence of the degree and scope of specialization in the trades. The rare Tyrian, or Murex, purple dye was of ideological importance especially to the Macedonian dynasty that designated its heirs as *Porphyrogenetos* (i.e., born in the palace's purple marble room). Analyses of the dye content in the surviving corpus of Byzantine textiles reveal that a small minority contains the fabled and prohibitively expensive true shellfish purple; most are combinations of indigo-blue dye, cross-dyed with madder or kermes red. Murex purple has been confirmed in the silk yarns weaving the clothing of the Virgin Mary in the famous *Sancta Sanctorum* silks, and in certain of the imperial eagle silks.

### Types of Textiles

The imperial production centers prioritized pattern-woven silks in mechanically repeated designs, produced with relative speed and ease on the draw-loom. Other types of textiles, such as plain woollens and linens, certainly coexisted with the prodigious output of the Constantinopolitan looms, but their survival rate is scant by comparison.

**Silk weaves.** Structurally, the great majority of the surviving patterned silks use compound twill (*samit*, *samitum*), in one or more colors. Plain weave (*tabby*) is represented; some display supplemental or compound patterning. A novel compound weave, *lampas*, appears in its fully developed version in which different weave structures are combined (such as plain weave and twill or satin), first in Baghdad, and presumably soon thereafter reaching Islamic Spain and Constantinople circa 1100.

**Tapestry.** Early Byzantine textiles rendered in tapestry technique with Greek inscriptions have survived in Egypt's dry sands in considerable numbers. Usually termed "Coptic," although some have been shown to be Syrian, they are made of linen and colored wool thread for making clothing components, *clavi*, and for decorative curtains and wall hangings. A later, rare and large eleventh-century example in silk, circa 2 meters square, was found in the tomb of Bishop Gunther (d. 1065); it depicts a mounted, triumphant emperor.

**Embroidery.** In classical texts, Greek women's needlework skills are celebrated, and establish traditions that lived on in Byzantine women's quarters, *gynaceae*. Groups of fourth- to seventh-century woolen embroidered panels for clothing and interior decoration with late antique themes and Greek inscriptions have been found in excavations in Egypt. The figures in the border of Empress Theodora's mantle in the famous Ravenna mosaic, for example, are thought to be embroideries. Needlework in the Palaiologan style survives in splendid works created for Russian monasteries from the fifteenth century.

### Design Motifs, Iconography

The meta-language of power and divine privilege in ancient Middle Eastern royal motifs and compositional schemes was assimilated in the cultures around the Mediterranean. Weavers in Tang Dynasty China (618–906) also adopted it for silk designs produced for trade. The animal motifs include lions, elephants, eagles, and fantasy hybrids such as the senmurv and griffin, often incorporating a tree-of-life, and nearly always framed by the ubiquitous decorated roundel, a long-lived style that only waned by the thirteenth century. Small floral and geometric motifs, also based on Sassanian models, include heart- and spade-shaped foliate motifs in horizontal or offset registers. During the periods of Iconoclasm (726–787, 814–843) when no figurative depictions of Christian divinities and persons were allowed, Constantinopolitan workshops favored motifs that evoked the

heritage of the late antique, depicting charioteers and hunt scenes.

See also **Textiles, Coptic**.

#### BIBLIOGRAPHY

There are still only a few monographs on Byzantine textiles. Most works cited below treat the topic in considerable detail, however, and in context.

Benjamin of Tudela. *The Itinerary of Rabbi Benjamin of Tudela*. Translated and edited by A. Asher. London and Berlin: A. Asher and Company, 1840.

Boak, A. E. R. "Notes and Documents: The Book of the Prefect." *Journal of Economic and Business History* 1 (1929): 597–618.

Falke, Otto von. *Kunstgeschichte der Seidenweberei*. Berlin: Verlag Ernst Wasmuth, 1921. Standard text, superseded in some respects by recent findings, still required reading. Exists in English translation.

Flury-Lemberg, Mechthild. *Textile Conservation and Research*. Bern: Abegg-Stiftung, 1988. Meticulously researched, comprehensive case studies.

Geijer, Agnes. *A History of Textile Art: A Selective Account*. Stockholm and London: Pasold Research Fund, 1979. Lucid and concise, a gold-standard survey.

Kalavrezou, Ioli. "Luxury Objects." In *The Glory of Byzantium: Art and Culture of the Middle Byzantine Era A.D. 843–1261*. Edited by Helen C. Evans and William D. Wixom. New York: The Metropolitan Museum of Art (1997): 218–253. Good survey in important, recent exhibition catalog.

Kislinger, E. "Jüdische Gewerbetreibende in Byzanz." In *Die Juden in ihrer mittelalterlichen Umwelt*. Weimar, 1991. Source for primary texts on pivotal role Jews played in trade and manufacture of textiles.

Martiniani-Reber, Marielle. *Soieries sassanides, coptes et Byzantines Ve-Xie siècles*. Lyon: Musée historique des tissus; Paris: Editions de la Réunion des musées nationaux, 1986. Fine, detailed catalog of this museum's textiles collections.

Mathews, Thomas F. *Byzantium from Antiquity to the Renaissance*. New York: Harry N. Abrams, 1998. Refreshing and synthesizing examination of the Empire and its aftermath.

Muthesius, Anna. *Byzantine Silk Weaving A.D. 400 to A.D. 1200*. Vienna: Verlag Fassbaender, 1997. A valiant and welcome attempt to catalog all surviving Byzantine silk examples; unfortunately, not all are illustrated. Indispensable for further fieldwork.

Petrova, Yevgenia, ed. *Russian Monasteries: Art and Tradition*. St. Petersburg: The State Russian Museum, 1997. A catalog of monastic art, including important embroideries.

Sandberg, Gösta. *The Red Dyes: Cochineal, Madder, and Murex Purple*. Asheville, N.C.: Lark Books, 1994. A richly illustrated guide to the history and technology of red dyes.

Shorta, Regula. "Zur Entwicklung der Lampastechnik." In *Islamische Textilkunst des Mittelalters: Aktuelle Probleme. Riggsberger Berichte 5*. Riggisberg, Switzerland: Abeggstiftung, 1997. One of the foremost textile-structure specialists accounts for the development of lampas.

Soucek, Priscilla P. "Artistic Exchange in the Mediterranean Context." In *The Meeting of Two Worlds: The Crusades and the Mediterranean Context*. Edited by Clifton Olds. Ann Ar-

bor, Mich.: The University of Michigan Museum of Art, 1981. An early contribution to the accepted notion of the shared Mediterranean heritage in art and architecture.

———. "Byzantium and the Islamic East." In *The Glory of Byzantium: Art and Culture of the Middle Byzantine Era, A.D. 843–1261*. Edited by Helen C. Evans and William D. Wixom. New York: The Metropolitan Museum of Art, 1997. A lucid and definitive contribution on the cultural interactions between Byzantium and Islam.

Vogt, A. *Constantin VII porphyrogénète: Le Livre des cérémonies*. Paris, 1935–1939. Primary source text.

Volbach, W. Fritz. *Early Decorative Textiles*. London: Paul Hamlyn, 1969. A discursive standby, with a focus on the Byzantine material.

Zagorsk Museum Collection. *Early Russian Embroidery in the Zagorsk Museum*. Moscow: Collection Sovietskaya Russia Publishers, 1983. Ample black-and-white illustrations add to this important Russian collection.

*Désirée Koslin*

**TEXTILES, CENTRAL ASIAN** Central Asia consists of a great sweep of landmass running from the Pacific Ocean, off the coast of Siberia, to the plains of central Europe, with high mountain chains edged with tundra and desert. The foothills, plateaus, and valleys are often luxuriant, supporting villages and towns. In the vast deserts, rivers nurture the isolated oasis cities. The great cultural centers of Asia—India, China, and Iran—lie beyond the mountains. These cultural centers both influenced and were influenced by Central Asian tradition. At the center of this landmass are the Pamir Mountains. The Tien Shan range runs up through Tajikistan, Uzbekistan, Kyrgyzstan, and Xinjiang to circle the Tarim Basin (Tarim Pendi) and the Taklimakan Desert. Beyond, the Altai Mountains separate Mongolia from the steppes of Kazakhstan.

Two major ethnic groups populated the area during prehistoric times. The people of Indo-European descent, who had an agrarian background, moved eastward and were responsible for the oasis settlements, while the nomadic Turkic tribes, belonging to a number of Mongoloid people, moved westward from the steppes.

The fertile ravine and upland areas, running in an arc from Iran to China, have a network of autonomous kingdoms; the oasis cities of the Silk Road were linked by trade and religious beliefs. From the first century B.C.E. to the Arab conquests of the eighth century C.E. the main kingdoms, known as khanates, were Chorasmia, largely Turkmenistan, Bactria, northern Afghanistan, and Soghdia (in the area of Uzbekistan) lying between two main rivers Amu and Syr Darya. Fergana included Uzbekistan and Tajikistan and ran up to the Osh area of Kyrgyzstan, with the cities of Nisa, Merv, Samarkand, Piandjikent, and Bamyan.

The vast open areas were home to a number of tribes whose way of life was nomadic. They moved over the vast

steppe lands with their herds of sheep and camels, as well as their horses, which gave them the mobility to strike at powerful enemies and subdue them. The horse was in a way their lifeline, as they could travel long distances living on the mare's milk and the fermented kumis. The Greek historian Heroditus (484–425 B.C.E.) wrote about the tribes, describing their mobile homes (yurta) and the seasonal movement over vast areas. The description would still fit the way of life of some Kazaks, who inhabit the remote area of Noi in Uzbekistan, and the Torkomans of remote parts of Turkmenistan and the extreme northern part of Iran.

The nomadic way of life led to the development of a range of textiles for fabrics used for their homes as protection from the harsh elements, and also as woven, felted, and embroidered objects. These made up furniture, containers, habitat, clothing, objects that marked the rites of passage, and exchange that built social ties. The woven designs signified their identity; many motifs had an esoteric meaning, helping them to control the evil spirits that governed the unknown.

The fleece of the sheep provided wool for felting, creating the yurta, caps, shoes, and coats. Wool was also spun, crocheted, knitted, and woven into fabrics. Excavations have revealed felted fibers indicating that this art was known from Neolithic times. The frozen Pazyryk burials (400 B.C.E.) of the Scythians have led to the discovery of extraordinary felts with complex patterns, woven carpets of great fineness, and embroidered silks, which reveal the sophistication of the culture of these people, who were termed “barbarians.”

Trade was carried out by the tribes from very early onward with the Chinese to the east, as well as with the Greeks to the west. The Silk Road may have existed from an earlier time, according to some scholars, than the historic date associated with Emperor Wu-ti (145–187 B.C.E.). The fact that Emperor Wu-ti negotiated with the King of Fergana for brood mares and stallions indicates that he wanted to play an important role in the exchange of commodities.

The excavations at Loulan and Niya by Sir Auriel Stein revealed rich colored figured textiles, felt, carpets, tapestry weaves, and remnants of wool garments and other fibers for wrapping bodies for burial. The rich tradition of textiles shared by the area indicates close links with China. The trade contacts also brought influences from India, as well as the near east. Pliny (41–45 C.E.) mentions trading with Central Asia since ancient times. Some of the finest historical textiles after the discovery of the Scythian burial sites are the Sogdian textiles woven from the seventh to the ninth centuries. The weft-faced complex twill woven in silk has patterns enclosed in roundels with juxtaposed animals and birds similar to the Scythian traditions. A common motif is paired ducks facing each other with a tree of life between them, and juxtaposed lions enclosed in circular beaded enclosures—a device very com-

mon among Sassanian textiles. However, the delineation of the hunt is powerful and shows a remarkable linear strength and mastery over the technique.

Under the Mongol leader Ghenghis Khan, a large number of Turko-Mongol tribes—the Sakas, Scythians, Sarmatians, and others—were united and controlled the entire area. Khan brought many masters of craft traditions, which enriched the Central Asian traditions and added to the cultural heritage. Upon Khan's death, Central Asia was divided amongst his sons. Uzbek Khan, (1312–1340) a descendant of Ghenghis Khan's son, ruled a large area, converted to Islam, and along with his followers became prominent in the area as their faith unified the people. At the end of fifteenth century, the Uzbek army conquered much of Central Asian territory, mixed with the settled population, and created a dominant group, enhancing the area, which is now known as Uzbekistan.

The Timurid Empire, from the mid-fourteenth century to the end of the sixteenth century, was a period of abundant cultural development of the urban settlements of Central Asia. Emperor Timur Lang followed the precept of his ancestor Genghis Khan and brought many of the masters of arts and crafts to his capital, and Samarkand began to produce woven textiles, which could compare to the very best.

The nomadic tradition continued throughout the period, maintaining many of the woven techniques and woven patterns that reflected their identity and way of life. For instance, the hearth rug was central to the Torkomans' yurta and had deep significance as well as distinctive patterns. The subjugation of the tribe would mean the introduction of the pattern of the dominant tribe in the hearth rug.

### Textile Materials

Wool was the most important fabric used, not only by the nomadic people but also by the settled population. Their flocks provided them with material, with men shearing and the women cleaning, sorting, and carding for spinning. Men, women, and children all spun the wool as they moved with their animals. Amongst the nomadic people, the women used local plants as the base and minerals as mordants and generally did dyeing. In the large urban centers such as Bokhara, Samarkand, and Fergana expert dyers were known for their skills. Two different groups of dyers were known in Bokhara, those who worked with cold dyes and those who used hot dyes. The cold dyes were the domain of the Jews in the area, while the hot dyes were the specialty of Tajiks and Chalas, who dyed mostly silk or cotton. Dyeing was considered to have mystic qualities. Its practice was kept a secret even from the daughters of the household, and a number of ceremonies and taboos were related to the practice.

Silk was obtained early from China, and there are Han records of 81 B.C.E. that talk of the importance of



trade with the Hsiung-nu (tribal people) for large quantities of gold, which reduced their resources and weakened the enemy. Silk was the dress of the elite and is still referred to as *padshaboki*, the king's cloth. Only those allowed to wear silk by the local ruler could use it, or else they could face imprisonment and even death.

Until the coming of the Soviet system of collectivization, sericulture was practiced as an individual activity in the rural areas or confined to small workshops in the towns. The process was quite primitive, and after the closure of the silk reeling factories in 1992, they returned to the old methods of processing.

Cotton was grown in the oasis from ancient times, and the women processed the cotton, ginning it by using traditional wooden hand rollers (*chirik*). It was then separated, rolled, and made ready for spinning with the use of a spinning wheel (*charakh*). The weaving of plain cotton (*carbos*) was done by the weavers. Very fine-spun thread was woven along with silk to produce the mixed silk and cotton fabric known as *adras* for which the area was famous and which was also in demand for exporting. Gold thread and silk embroidery was sought after for the rich garments worn by the elite and for the production of *khillats*, royal robes of honor presented to distinguished guests or for esteemed members of their own clan. Bokhara was known for its expert gold embroiderers.

### Felting and Weaving Techniques

The techniques can be divided into nomadic and urban, though the distinction cannot be rigid. Among the nomadic people the women for their own use did weaving, while in the urban centers it was the work of men, though in some cases there were looms in the home, which were used by the women.

Felting was essentially a nomadic tradition and was carried out with pure wool. Two types of felts were created: the plain single natural color of the wool used for the making of apparel or for the yurta, and the patterned ones known as *alakhbiz*. The patterns were integrated into the felt by laying the designs on a canvas with use of long slivers of loosely twisted dyed wool and then covering the pattern with finely carded single colored wool. The finest *namads* (Iranian artisan felt rugs) of inlay designs were made by the Torkomans and also by the Kyrgyz women, a tradition that was found in the Pazryz burial mounds. Sprinkling the fibers with water mixed with a soap solution and rolling them with the feet and hands would result in a thick felt. Shaped caps, coats, jackets, mittens, and shoes were also made and decorated with embroidery. Another popular form of patterned felt was the *shirdak* created by cutting dyed felt pieces and creating myriad patterns, which was a specialty of the Kyrgyzi.

Weaving of plain and twill weave woolen cloth for apparel was common and similar to the type found in ancient burial sites. The fine woolen weaving was for creation of shawls, which were used by men and women, as

well as fine cloth for the long gowns—*abas*—worn by the priests, as wool was considered pure. Very fine quality lengths were woven for the *imame* worn as turbans in earlier times. The shawls were woven with motifs on the border with silken dyed threads.

The mastery of the woolen technique was in the weaving of flat weaves for rugs and for hangings. Non-continuous weft weaving was used for *soamak* weaves with intricate multicolored woven patterns. Another technique with noncontinuous weft was the method of interlocking tapestry. Both of these techniques later evolved into highly specialized weaving traditions, the *termeh*, which is associated with the Persian shawl weaving, and *kesi*, an intricate form of silk tapestry with interlocking weave. Recent research has revealed examples of *kesi*, which appear to have all the characteristics of Soghdian textiles with a liveliness of the flow of the patterns and brilliant use of color. An interesting *kesi* of the thirteenth century in the Metropolitan Museum has floating leaves, buds, and flowers, with ducks swimming among them. It has the spontaneity of the Soghdian textile repertoire. The earliest *kesi* to be found is in Turfan, which dates to the sixth century C.E.

Soghdian brocades of silk were used for creating apparel, as well as for funerary cloth. Woven in weft-faced compound twill, its technique is quite distinct from the Chinese style of silk patterned brocade.

The settlement of Muslim weavers in Central Asia by Ghengis Khan, of which two settlements are mentioned in the records of the period, contributed greatly to the stylistic development of designs and techniques. Khan also brought weavers from China and settled them in Samarkand, leading to a blending of styles and technical skills. The greatest contribution is their expertise in weaving cloth of gold known as *nasij*.

Another important silk technique was the warp ikat known as *abr*. While the word means cloud, it here refers to the ikat technique and *khan atlas* for the pure silk of very fine patterns often woven with seven colors. Bokhara, Samarkand, and Fergana were the centers for these very dramatic fabrics with rich colors and bold patterns. Research being carried out by the newly opened Department of Cultural History in Uzbekistan has located Sukhandarya as a place where ikat silk was also woven. Known locally as *abrabandi*, the technique is generally seen as having been introduced rather late, in the eighteenth century, but it is likely that this technique was used much earlier. The degummed washed silk warp threads were marked by the *nishanzan* or the designers, who chose a range of patterns derived from the diverse repertoire of patterns of Central Asia. They include ram's horns, tulips, pomegranates, *kora-karga*, black ravens, the *badam*, almonds, peacocks, cloud motifs, *shonagul*, comb design, as well as bold *oi*, the circular moon motif in blue and the red sun motifs combined with a stylized dragon. During the Soviet era, they created *Ulag Oktyabr*, Octo-

ber Revolution, and Kremlin patterns. The most prized and complex patterns in the ikat technique were the *bakmal*, the ikat velvet, which was highly valued and was reserved for the royalty.

The mixed cotton weft and silk warp-faced ikats known as *adras* were very popular as most households could wear these. Pure cotton striped ikat, *yalong doveran*, was also woven and was in great demand as only the royal household and those permitted by them were allowed to wear pure silk, while cotton could be worn by everyone. Often these were given to the *kudunggars*, the glossing workshop where the material was glazed with egg white and polished.

A range of cotton fabrics was woven. *Alacha* and *kalami* were fine striped cotton. One of the most popular striped materials was known as *masbku-zafar* and was woven with black and saffron-yellow. Textured cottons woven with threads of different counts created a rich effect and were known as *Salori bular*.

Central Asia has a tradition of printing on cotton and silk. It appears to have been practiced from ancient times, which is confirmed by the discovery of a fragment in an excavation carried out near Termez in Sukhandarya region of Uzbekistan. A fragment was also found in the fourteenth century C.E. grave of Bibi Kanum, wife of Tamerlane. The direct printing with the use of wooden blocks, *qalib*, was prepared in Bokhara, Samarkand, Fergana, Qorcom, Tashkent, as well as in Tajikistan bordering the Ferghan Valley. It is interesting that the word for printing is *chint*, which is also used in India. The printer is *chintsar*. *Chintsaz* is the word used in Isfahan, Iran, as well as in India. The carver of the blocks is known as *kolkbbhar*. Some scholars are of the opinion that possibly printing came from India. Research in India has, however, revealed that *chipa* for the printer and *chint* for printed cloth are not Sanskrit words.

The silk gauzelike cloth was printed with resist-printing near Bokhara in a town known as Chidgaron, which was known for its printing. Between 1840 and 1849, 2,500,000 printed cloth pieces of each were exported to Russia and Bokhara. Unfortunately the silk-resist printed scarves are no longer being produced.

Silk embroidery known as *suzan dozi* was practiced throughout Central Asia. The style of embroidery, however, was quite distinct even within the same tribe. Uzbekistan has the richest variation, the *suzani* of Nouratta has great delicacy and is quite distinct from that of Bokhara, Samarkand, and Sukhandarya. Some settled people use satin stitch, while stem stitch is used for the more delicate motifs. Chain stitch with the use of the needle or the awl is used specially for bolder work and that prepared on leather, suede, or felt. *Basma* is a form of couching used for either gold embroidery or for bolder work covering large areas, as for the *suzanis* used as tent hangings. One of the most interesting embroideries is the Lakai embroidery, which often uses wool for the embroidery and

has a bold primitive appearance and asymmetrical motifs. The embroidery of the Torkomans is very bold and done on silk with silken threads.

Gold embroidery often worked on velvet dresses was an essential part of the embellishment carried out on robes used by the royalty, their families, and court, and the robe of honor was often worked in rich gold thread. Bokhara was the most important center for this work, and many workshops specialized in this.

A range of techniques was prevalent and enriched the dress of the people of Central Asia. Their love of brilliant colors and bold patterns created a richness in the rather arid conditions of Central Asia.

*See also* **Dyeing, Resist; Felt; Ikat.**

#### BIBLIOGRAPHY

- Abdullaev, T., et al. *A Song in Metal: Folk Art of Uzbekistan*. Tashkent, Uzbekistan: Gafura Guliyama, 1986.
- Asian Costumes and Textiles from the Bosphorus to Fujiyama*. Milan, Italy: Skira, 2001.
- Beresneva, L. *The Decorative and Applied Art of the Turkmen*. Leningrad, Russia: Aurora Art Pub., 1976.
- Block Printing in Uzbekistan: Past and Present*. Tashkent, Uzbekistan: UNDP, 1979.
- Burkett, Mary E. *The Art of the Felt Maker*. Kendal, U.K.: Abbot Hall Art Gallery, 1979.
- Grube, Ernst J. *Kesbte: Central Asian Embroideries*. New York: Marshall and Marilyn Wolf, 2003.
- Kirghyz Arcok es Himzesek*. Neprajzi Museum, 1995.
- The Kirghyz Pattern*. Kyrgyzstan, 1986.
- Morozova, A. S. *Folk Art of Uzbekistan*. Tashkent, Uzbekistan, 1979.
- Pope, A. V., and P. Ackerman. *A Survey of Persian Art*. New York: Oxford University Press, 1939.
- Undeland, Charles. *The Central Asian Republics: Fragments of Empire, Magnets of Wealth*. New York: The Asia Society, 1994.
- Vollmer, John E., E. J. Keal, and E. Nagai-Berthrong. *Silk Roads, China Ships*. Toronto: Royal Ontario Museum, 1983.
- Watt James, C. Y., and Anne E. Wardwell. *When Silk Was Gold: Central Asian and Chinese Textiles*. Abrahams, New York, 1997.
- Zhao Feng. *Treasures of Silk: An Illustrated History of Chinese Textiles*. Hong Kong: ISAT/Costume Squad, 1999.

*Jasleen Dhamija*

**TEXTILES, CHINESE** Silk production, characteristic of China's earliest civilization, has been an enduring feature of Chinese tradition and a distinctive aspect of China's interaction with other cultures. From China's Neolithic era, hemp and ramie were cultivated and woven into textiles for clothing and other uses. Wool textiles played a minor role, associated with border peoples of the north and west. Cotton cultivation began at least by the eighth century. By the Ming dynasty (1368–1644),



### SILK AND DIPLOMACY

The value of silks for diplomatic gifts was recognized early. Confucian texts of the third century B.C.E. mention the practice. During the Song dynasty (960–1279), some diplomatic gifts to border peoples included 200,000 bolts of silk.

In the first century C.E., Pliny the Elder wrote in his *Natural History* (Book XII, translation by H. Rackham, 1952, p.3): “This inspires us with ever greater . . . wonder that starting from these beginnings man has come to quarry the mountains for marbles, to go as far as China for raiment, and to explore the depths of the Red Sea for the pear.”

In 1912 Sir Aurel Stein (1862–1943) described the textiles found in the “walled up temple library,” at Dunhuang, including a large embroidery of a Buddha with bodhisattvas, an embroidered cushion cover with scrolling floral motifs, “a number of triangular headpieces . . . detached from their painted banners . . . composed either in their body or in their broad borders of pieces of fine silk damask,” and “a silk cover . . . intended for a manuscript roll” (Stein, pp. 207–210). The objects collected by Stein are now in the British Museum and the Museum of Central Asian Antiquities in New Delhi, India. Textiles were also collected at Dunhuang by the French archaeologist Paul Pelliot (1878–1945), now preserved in the Musée Guimet and the Bibliothèque Nationale, Paris. Another group of Dunhuang materials is in St. Petersburg, and more recent finds are kept in Chinese collections.

it had become an industry to rival silk production. Though silk retained its role as a luxury fabric and a symbol of Chinese culture, cotton cloth ultimately became a widespread material and an economic staple.

From the Han dynasty (206 B.C.E.–220 C.E.), silk manufacture comprised a major state-controlled industry. For thousands of years, along land routes through Central Asia and sea routes along the coasts of East and Southeast Asia, silk was both a major commodity and at times a standard medium of exchange. In China’s diplomacy, silk played a stabilizing role, bringing large areas of Inner Asia into the Chinese sphere of influence. At home, silk production was viewed as a moral imperative as well as a practical necessity. The Confucian adage, “men till, women weave,” expresses the essential role of the women in a household in preparing silk yarn and cloth. Later, an increase in industrial specialization encouraged a shift of women’s efforts from weaving to

needlework, and yet the spirit of the phrase was preserved. As late as the seventeenth century, the state collected taxes in silk as well as in grain, underscoring the essential value of this human endeavor. Ultimately, the uses of silk expanded to include textiles made for appreciation as art as well as for clothing and furnishings.

Elaborate techniques were developed for producing complex designs, both in the woven cloth itself and in embellishments worked onto the surface. Brocades, weaves with supplementary weft yarns creating complex patterns, were employed in many variations, including the complex lampas weave with its extra binding warps. *Kesi*, a tapestry weave, perhaps originally developed by Central Asians with wool yarn, came to be highly refined in the works of Chinese weavers of the Song dynasty (960–1279) and later. Embroidery, a means of embellishing a woven fabric with stitches made using a threaded needle, flourished throughout the history of silk textiles in China.

### Historical and Archaeological Evidence

Needles have been found in some of China’s earliest inhabited sites. Abundant evidence of the making of fabrics from hemp and ramie has been found in sites of the fifth millennium B.C.E. Spindle whorls of stone or pottery found in these sites confirm the spinning of hemp or ramie fibers into threads for weaving and sewing. Components of what may have been a backstrap loom have also been identified. Impressions of woven materials on the bases of pottery vessels, such as those found at Banpo, Shaanxi province, suggest the varied uses of coarse cloth or matting, in this case to create a simple turntable for pottery making. Remains at sites of the Liangzhu culture of the Lower Yangtze River region confirm the initiation of sericulture by the third millen-



### THE MANILA GALLEON

The fall of Constantinople in 1453 disrupted trade and led Europeans to find their own sea routes to Asia. Chinese silk textiles were included in the earliest voyages of the Manila galleon in 1573. According to the inventory by Antonio de Morga, president of the *audiencia* at Manila, Spanish traders bought:

raw silk in bundles, . . . fine untwisted silk, white and of all colors, . . . quantities of velvets . . . others with body of gold and embroidered with gold; woven stuffs and brocades, of gold and silver upon silk . . . gold and silver thread . . . damasks, satins, taffetas, . . . linen . . . cotton. (Schurz, p. 73)



nium B.C.E. Here can be found the earliest confirmed evidence of the development of the complex process of raising silkworms (*Bombyx mori*), harvesting the filaments from their cocoons and then reeling the silk and weaving it into cloth.

### **Shang (c. 1550 B.C.E.–1045 B.C.E.) and Zhou (c. 1045 B.C.E.–221 B.C.E.) Dynasties**

Tombs of China's Bronze Age provide evidence that silk, like bronze and jade, was a luxury commodity, important for ritual use. The royal tombs at Anyang, Henan province, reveal that ritual bronze objects and also ritual jades were wrapped in silk before being buried as grave goods. In the tomb of Lady Fu Hao (twelfth century B.C.E.), more than fifty ritual bronzes are known to have been wrapped in silk cloth. Anyang silks included various weaves, damasks as well as plain (tabby) weave, and some examples were embroidered with patterns in chain stitch.

Spectacular finds of Zhou dynasty silks from the Warring States period (453–221 B.C.E.) are identified with the distinctive Zhou culture centered in China's middle Yangtze River valley. A tomb at Mashan, Hubei province (datable to the fourth century B.C.E.), yielded the following silks: a coffin cover, a silk painting, bags of utensils, costumes on wooden tomb figures, and nineteen layers of clothing and quilts around the corpse itself. Plain silks, brocades, and plain and patterned gauzes were included as well as embroidery in cross-stitch and counted stitch. Analysis of the complex and densely woven Mashan silks has led scholars to suggest that an early form of the drawloom must have been used to produce them.

Other well-known finds from the Zhou culture confirm the early use of silk as a ground for painting, specifically in two third-century B.C.E. pictorial banners used in funerary rituals and then buried with the deceased. A work known as the "Zhou Silk Manuscript," dated to circa 300 B.C.E., documents the tradition that early Chinese texts were written on silk cloth and bamboo as well as cast in bronze or carved on stone. Examples of shop marks have been found on silks of this period, including a brocade with an impressed seal, suggesting a growing respect for distinctive workshop products and the commercial value of textiles.

Archaeological finds outside China's traditional borders confirm the scattered early references to China's export of silk to neighboring lands. In the Scythian tombs at Pazyryk in the Altai mountains of Siberia (excavated in 1929 and 1947–1949) silks datable to 500–400 B.C.E. were found together with textiles of Near Eastern origin. This evidence gives credence to the belief that the Greeks had imported Chinese silk by the fifth or fourth century B.C.E.

### **Qin (221–206 B.C.E.) and Han (206 B.C.E.–220 C.E.) Dynasties**

Having built the first empire of China, Qin Shi Huangdi (best known in the early 2000s for the 1974 discovery of

his "terra-cotta army") built a great palace. Among its remains have been found silks, including brocade, damask, plain silk, and embroidered silk. After the reconsolidation of the empire under Han imperial rule, silk production became a primary industry, with state-supervised factories employing thousands of workers who produced silks and imperial costumes. Officials were sometimes paid or rewarded with silk textiles. As stability declined at the end of the period, textiles and grain replaced coinage as a recognized medium of exchange.

The legacy of the former state of Zhou continued to flourish, as shown by the rich treasures found at the noble tombs at Mawangdui, Hunan province (second century B.C.E.). Here was preserved silk clothing in fully intact robes. In addition there were manuscripts, maps, and paintings on silk, including elaborate funerary banners showing a portrait of the deceased entering an afterworld of cosmic symbols and signs of immortality. Embroidered silks follow patterns seen in the earlier Mashan silks, using chain stitch worked in cloud-scroll patterns. Printed silks found at Mawangdui correspond to a relief stamp found in the tomb of the Second King of Nan Yue (in Guangzhou, datable to before 122 B.C.E.), providing confirmation that techniques and styles had spread throughout the empire.

Han tombs have yielded a variety of silks, including plain weave, gauze weave, both plain and patterned, and pile-loop brocade similar to velvet. More than twenty dyed colors have been identified. Embellishment of woven fabrics included new techniques of embroidery incorporating gold or feathers, as well as block-printing, stenciling, and painting on silk. Later Han silks include a striking number of woven patterns with texts, usually several characters with auspicious meanings. From pictorial representations, scholars have deduced that Han weavers used treadle looms.

Finds in remote areas have added to our understanding of production and commerce relating to silk textiles. Sir Aurel Stein found in Western China a strip of undyed silk inscribed by hand stating the origin, dimensions, weight, and price. A seal impression designates its origin in Shandong province in Northeast China. Other finds established the standard selvage-to-selvage width of Han silk, at between 17½ and 19½ inches (from 45 to 50 centimeters). At Loulan, in the Tarim Basin in the far Northwest of modern China (Xinjiang province), excavated by Stein (1906–1908 and 1913–1914), Han figured silk textile fragments (datable to the third century C.E. or earlier) were found together with an early example of slit tapestry woven in wool. The latter may be a precursor of the later *kesi* slit tapestry in silk. Finds at Noin-Ula, in northern Mongolia, dated second century C.E., give further evidence of the widespread exchange of silks throughout Asia. Although details of the trade are yet to be fully understood, comments by early writers make clear the admiration for Chinese silks in the Roman world.



**The Birds and the Flower, National Palace Museum, Taiwan.** In the Song Dynasty, textile production was fine-tuned with such artistry as the weaving of *kesi* tapestries and the development of needle-loop embroidery. THE ART ARCHIVE/NATIONAL PALACE MUSEUM TAIWAN/HARPER COLLINS PUBLISHERS. REPRODUCED BY PERMISSION.

### Six Dynasties Period (220–589) and the Tang Dynasty (618–907)

Political disunity during the third to sixth centuries brought close interaction with Central Asia, leading to new styles and techniques relating to textile production. Tang silks reflect these closer contacts established during the previous centuries. The Tang maintained an open capital with foreigners among its merchants and varied ethnic and religious groups among its populace. A general shift in weaving techniques distinguishes Tang silk from that of the Han dynasty. While Han patterns were warp-patterned, the weavings of Tang came to be weft-patterned.

Some of the best Tang textiles survive in temples in Japan, where Chinese fabrics have been carefully preserved in Buddhist temples since before the eighth century. The most important of these holdings is that of the Shōsō-in (a storehouse dedicated at Tōdai-ji, Nara, in 756, for the donated collection of Emperor Shōmu), which contains various garments and other textiles believed to have been brought back to Japan by Buddhist monks returning from China.

Investigation of Chinese textiles was stimulated by stunning discoveries of well-preserved ancient textiles in Central Asian sites, including Sir Aurel Stein's expeditions in northwest China and inner Asia (in 1900, 1906–1908, 1913–1916 and 1930). Discoveries at Dunhuang's Buddhist cave temples yielded a new range of textiles for study, and brought about an early appreciation of the importance of textiles in Buddhist ritual. Such textiles were probably pious offerings made by Buddhists from Central Asia, especially Sogdiana, as well as from China. Many of the silks were sewn into banners or other adornments for Buddhist chapels, or into wrappers for sacred texts (sutra scrolls). A mantle (*kashaya*) for a Buddhist priest, its patchwork symbolizing the vow of poverty, was also found. Many of the silk textiles have bright patterns, woven or embroidered, while others were adorned after weaving by painting, printing, stenciling, or by dyeing using resist techniques including clamp-resist, wax-resist and tie-dyeing. The weaving techniques documented in these finds include silk tapestry (*kesi*), gauze, and damasks, as well as compound weft-faced and warp-faced weaves that were probably woven on a drawloom. These finds confirm that patronage of Buddhism encouraged creation of pictorial textiles either woven in the *kesi* technique or embroidered with highly refined use of stitches (often satin stitch) to create representational effects.

Important examples of Tang silks have been found at Famen Temple, Shaanxi province. Here, a ritual offering datable to C.E. 874 included about 700 textiles including brocades (many with metallic threads), twill, gauze, pongee, embroidery, and printed silk. Among them was a set of miniature Buddhist vestments including a model of a *kashaya*, an apron (or altar frontal), and clothing, all couched with gold-wrapped threads on a silk gauze ground in patterns of lotus blossoms and clouds.

### Song Dynasty (960–1279)

Song weavers brought refinement to textile technology, especially the weaving of satin and of *kesi* tapestries. Generally the use of gold and silver increased both in embroidery and in woven brocades. Needle-loop embroidery, a detached looping stitch sometimes combined with appliqué of gilt paper, came into use. In Song times as in the Tang, embroidery and tapestry were used for devotional Buddhist images, but now the techniques were also employed to create items for aesthetic appreciation, like paintings, in the form of scrolls or album leaves.

### Jin (1115–1234) and Yuan (1279–1368) Dynasties

Silk played a major role in trade, diplomacy, and court life under the Jin dynasty, founded by the Jurchen, a Tatar people, and the Yuan, founded by the Mongols, both non-Chinese ruling houses. Jin and Yuan brocades, notable for rich patterning with gilt wefts of leather or paper substrate, have been a focus of recent exhibitions. Due to the open trade connections encouraged by the Mongol con-

quests, these silks spread widely. Examples reached the pope through trade and diplomatic gifts. Thus, the cloth of gold favored by Mongol leaders had its counterpart in the *panno tartarico* of fourteenth-century Europe.

#### Ming Dynasty (1368–1644)

By Ming times, weavers employed elaborate drawlooms using up to forty different colored wefts and incorporating flat gold (gilt paper) strips, gold-wrapped threads as well as iridescent peacock feathers to produce their brocades. The Yongle reign (1403–1424) saw a tremendous dedication of resources to the production of diplomatic gifts including textiles for Buddhist purposes, a practice carried over into the Xuande reign period (1426–1435). Excavations at the tomb of the Ming emperor Wanli (reigned 1572–1620) yielded two complete sets of uncut woven silk for dragon robes, as well as silk brocades and patterned gauzes marked as products of the imperial workshops in Nanjing and Suzhou.

By the late sixteenth century, cotton cultivation, which had been encouraged under the Yuan dynasty and expanded further under the Ming, became a major part of the Chinese economy. From at least Tang dynasty times, cotton had been used to make clothing for the lower classes (Cahill [p. 113] observes that “cotton-clad” meant a commoner in medieval Chinese poetry). In subsequent centuries, cotton cloth was associated with the virtues of humility. Ginned cotton was transported south from Henan and Shandong provinces, or shipped north from Fujian and Guangdong, to the Jiangnan region where it would be made into thread and woven into cloth. Cotton thread is noted among Chinese exports to Japan, and white cotton cloth as well as cotton garments of blue or white are recorded among the items exported on the Manila galleon.

Domestically, cotton found wide use in undergarments and in linings for silk (such as in silk garments for ceremonial use), and it also came to be dyed in bright colors and calendered to an attractively polished surface. The most distinctive artistic developments in Chinese cotton textiles are those that survive primarily in rural traditions and folk art relating to minority groups, including the Miao of Guizhou and Yunnan provinces. The primary techniques, resist dyeing (using stencils to apply a paste that would retain white undyed areas), and batik (using wax to reserve undyed areas), had been known in China, along with block printing, tie-dyeing, and clamp-resist, since the Han dynasty, and are found in silk examples preserved from the Tang period. The characteristic blue from indigo, typical of dyed cotton, also reflects an ancient tradition, recorded in detail in Ming dynasty texts.

Anthropologists and historians have noted a shift in importance among China’s women from activities in weaving to embroidery in the seventeenth century. Increasing specialization meant that finished yarn and finished cloth could be purchased routinely. This spurred a rising interest in embroidery among the gentry, and a re-

lated rise in the status of embroidery to verge upon that of the fine arts of painting and calligraphy. The Gu family of Shanghai, for example, came to prominence for their distinctive pictorial embroidery style. A manual of embroidery designs compiled by the scholar-calligrapher Shen Linqi (1602–1664), published in woodblock-printed form, set out themes and patterns that inspired embroiderers for centuries.

#### Qing Dynasty (1644–1911)

Study of Qing textiles has focused on the court collections, now in Beijing’s Palace Museum and in the National Palace Museum, Taipei, including wall decorations, curtains, desk frontals and upholstery fabrics, ceremonial and informal costumes, and works of art. When the Qianlong emperor, inspired by scholar-collectors of the late Ming as well as by the precedent of the Song Emperor Huizong (reigned 1101–1125), commissioned scholar-officials to catalog his art collections (producing the *Bidian Zhulin* and the *Shiqu Baoji*, published in 1744–1745, 1793, and 1816) these catalogs included examples of *kesi* and embroidery alongside painting and calligraphy. Qianlong himself may have selected works to be “reproduced” in *kesi*, including his own painting and poetry and works in his collection of painting and calligraphy.

The Qing emperors were Manchus whose homeland was in the far Northeast beyond China’s traditional borders. When they conquered China, they were quick to adopt the Chinese practice of using gifts of silk, particularly cloth for dragon robes, as a means to bring the powerful leaders of vassal states into their own military bureaucracy. The Qing forebears had been on the receiving end of this practice during the late Ming period. Silk had long been used to pacify border peoples; Song examples are striking, but the practice began before the Han dynasty. Most visible among textiles surviving up to the twenty-first century are the lavish silk brocades bestowed upon Tibetan nobles and preserved in Tibet’s dry climate until recent years.

#### Collecting and Study of Textile

Until recently, the study of Chinese textiles revolved around Beijing’s imperial palaces, a focal point for interest in Chinese culture after the end of Qing dynasty rule in 1911. In the years before the formal establishment of the Palace Museum within the former Forbidden City in 1925, many court costumes and other textiles were dispersed into collections worldwide. Western scholars took a keen interest in Chinese textiles as they came to know them through these court robes and interior furnishings. In recent years, collections have been technically analyzed and historically documented in studies carried out at the Association pour l’Étude et la Documentation des Textiles d’Asie (AEDTA), Paris; the Royal Ontario Museum, Toronto; Hong Kong Museum of Art; the Metropolitan Museum of Art, New York; the Cleveland Museum of Art; Los Angeles County Museum of Art; the Phoenix



Art Museum; the Chicago Art Institute; and the Minneapolis Institute of Arts.

See also **China: History of Dress; Silk.**

#### BIBLIOGRAPHY

- Arnold, Lauren. *Princely Gifts and Papal Treasures: The Franciscan Mission to China and Its Influence on the Art of the West, 1250–1350*. San Francisco: Desiderata Press, 1999.
- Bray, Francesca. *Technology and Gender: Fabrics of Power in Late Imperial China*. Berkeley: University of California Press, 1997.
- Brook, Timothy. *The Confusions of Pleasure: Commerce and Culture in Ming China*. Berkeley: University of California Press, 1998.
- Brown, Claudia, et al. *Weaving China's Past: The Amy S. Clague Collection of Chinese Textiles*. Exhibit catalog. Phoenix: Phoenix Art Museum, 2000.
- Cahill, Suzanne. "Our Women Are Acting Like Foreigners' Wives!": Western Influences on Tang Dynasty Women's Fashion." In *China Chic: East Meets West*. Edited by Valerie Steele and John S. Major. New Haven, Conn.: Yale University Press, 1999.
- Feng, Zhao. *Zhixiu zhenpin: Tushuo Zhongguo sizhou yishu shi/Treasures in Silk: An Illustrated History of Chinese Textiles*. Hong Kong: ISAT/Costume Squad Ltd., 1999. In Chinese and English.
- Hanyu, Gao. *Chinese Textile Designs*. Translated by Rosemary Scott and Susan Whitfield. London: Viking, 1992.
- Jacobsen, Robert D. *Imperial Silks: Ch'ing Dynasty Textiles in the Minneapolis Institute of Arts*. Chicago: Art Media Resources Ltd., 2000.
- Komaroff, Linda, and Stefano Carboni, eds. *The Legacy of Genghis Khan: Courtly Art and Culture in Western Asia, 1256–1353*. Exhibition catalog. New York: The Metropolitan Museum of Art, 2002.
- Kuhn, Dieter. "The Silk Workshops of the Shang Dynasty (16th–11th century B.C.E.)." *Explorations in the History of Science and Technology in China: A Special Number of the "Collections of Essays on Chinese Literature and History."* Edited by Li Guohao et al., 367–408. Shanghai: Chinese Classics Publications House, 1982.
- Ledderose, Lothar. *Ten Thousand Things: Module and Mass Production in Chinese Art*. Princeton, N.J.: Princeton University Press, 2000.
- Nai, Xia. *Jade and Silk of Han China*. Edited and Translated by Chu-tsing Li. Lawrence, Kans.: Spencer Museum of Art, 1983.
- Nengfu, Huang, ed. *Yin ran zhi xiu* (Printing, dyeing, weaving, and embroidery). In *Zhongguo meisbu quanji: Part 3—Gongyi meisbu bian* (The great treasury of Chinese fine arts: Part 3—Arts and crafts). Vols. 6 and 7. Beijing: Wenwu chu ban she, 1985 and 1987. In Chinese.
- Pu, Lu. *Designs of Chinese Indigo Batik*. Beijing: Beijing New World Press, 1981.
- Riboud, Krishna. "The Silks of Dunhuang." In *The Arts of Central Asia: The Pelliot Collection in the Musée Guimet*. Edited by Jacques Giès, 115–120, 155–164. Paris: Serindia Publications, 1996.
- Schurz, William. *The Manila Galleon*. New York: E. P. Dutton, 1939.
- Steele, Valerie, and John S. Major. *China Chic: East Meets West*. New Haven, Conn.: Yale University Press, 1999.
- Stein, Sir Marc Aurel. *Ruins of Desert Cathay: Personal Narrative of Explorations in Central Asian and Westernmost China*. London: Macmillan and Company, 1912. Reprint, New York: B. Blom, 1968.
- Urban Council, Hong Kong, and the Oriental Ceramic Society of Hong Kong in association with the Liaoning Provincial Museum. *Jinxu luoyi qiao tiangong / Heavens' Embroidered Cloths: One-Thousand Years of Chinese Textiles*. Exhibition catalog. Hong Kong: Hong Kong Museum of Art, 1995. In Chinese and English.
- Vollmer, John, et al. *Clothed to Rule the Universe: Ming and Qing Dynasty Textiles at the Art Institute of Chicago*. Exhibition catalog. The Art Institute of Chicago. Seattle: University of Washington Press, 2000.
- Watt, James C. Y., and Anne E. Wardwell, with an essay by Morris Rossabi. *When Silk Was Gold: Central Asian and Chinese Textiles*. Exhibition catalog. New York: The Metropolitan Museum of Art, 1997.
- Wilson, Verity. *Chinese Dress*. London: Victoria and Albert Museum, 1987.

Claudia Brown

**TEXTILES, COPTIC** An estimated 150,000 textiles were found in Egyptian burial sites that date from the late third to mid-seventh century C.E., Egypt's Coptic Period. Most of these grave goods were fragments of clothing and domestic textiles, but some were nearly complete costumes. These archaeological fabrics represent the fashions and furnishings of that distant time and place.

#### The Coptic Period

Egypt was conquered by Alexander the Great in 332 B.C.E., then colonized and ruled by Greek pharaohs, the Ptolemies. After 30 B.C.E. Egypt was ruled from Rome, later from Byzantium, and briefly from Persia prior to the Islamic conquest of 641 C.E. Christianity became the dominant religion during the Coptic Period. A "Copt" in early usage identified an indigenous Egyptian, but in modern usage only a Christian Egyptian is a Copt. After 451 C.E. the Coptic Church separated from the Roman Catholic Church. There are six million Copts in 2004. Christian burial practices were adopted after the prohibition of mummification in the fourth century C.E. The deceased were dressed in their garments, swaddled with other cloth, and buried in sandy, shallow graves; or, in some instances, in small brick-covered vaults. The dry desert climate preserved the textiles.

#### The Discovery of Coptic Textiles

Some Coptic textiles were discovered as early as the seventeenth century and others during Napoleon's expedi-



### PHASES OF COPTIC TEXTILE ART

The conquest and colonization of one country by another creates a rich cultural brew that transforms indigenous art. Though Coptic scholars use different descriptive terms, they generally agree that the style of the tapestries and other pictorial textiles can be sorted into these broad categories:

#### *Pre-Coptic*

The Pre-Coptic category (first to late third centuries C.E.) includes only a few painterly examples.

#### *Early Coptic*

The Early Coptic, Proto-Coptic, or Late Roman-Egyptian category (late third century to fourth century C.E.) is dominated by Greco-Roman influence with themes drawn from nature and mythology. Subtle modeling with blended colors can be seen in the polychrome textiles and fluency of line is evident in the monochrome faces and figure drawn with the ecru linen wefts. Monochrome interlace and endless knot motifs are also popular and enduring.

#### *Middle Coptic*

The Middle Coptic, High Coptic, or Early Byzantine (fifth to mid-seventh century C.E.) is categorized

by the abstraction of naturalistic elements. Color areas, no longer blended, are separated by heavy outlines or juxtaposed. Faces and figures are distorted. Christian saints and symbols begin to replace the pagan iconography.

#### *Late Coptic*

The Late Coptic (mid-seventh to twelfth century C.E.) category extends into the Islamic period in which geometric patterns and calligraphic motifs supersede figurative art.

Polychrome and monochrome palettes were used throughout all phases and some popular themes, especially dancing figures and interlace patterns persisted. While there was continuity throughout the Coptic period in the construction, composition, content, and palette of the tapestries there were profound changes in the iconography. The naturalistic style of rendering faces, figures, and narrative vignettes was altered by abstraction, and familiar Greco-Roman motifs and themes were imbued with Christian messages.

tion to Egypt. Nineteenth and early-twentieth-century excavations at Saqqâra, Akhmîm, Hawarah, Karanis, and other sites by Theodor Graf, Wladimir Bock, Gaston Maspero, Sir Flinders Petrie, and other Egyptologists contributed to the textile collections of European museums. However, the impact of Coptic textiles on the history of clothing, fashion, art, and archaeology can best be understood by examining the career of the charismatic, but controversial, French Egyptologist Albert Gayet (1856–1916). He collected tens of thousands of textiles between 1895 and 1910, primarily from Antinoé (ancient Antinoöpolis), but also from Akhmim, Sheikh-Shata, Deir-el-Dyk, and Dronkah. Gayet believed he had discovered at Antinoé “. . . an efflorescent civilization to rival Pompeii.”

Gayet became known as “The Archaeologist of Antinoé.” Antinoé was founded in 130 C.E. by Emperor Hadrian. Drawings of Antinoé made during Napoleon’s 1804 expedition to Egypt reveal the grandeur of this Greco-Roman city with its broad avenues, impressive triumphal arches, temples, theaters, and baths. The city was colonized by cultured, literate citizens of Greco-Egyptian ancestry who called themselves the *New Hellenes*. Antinoé slowly declined after the seventh-century

Islamic conquest of Egypt. Eventually, even the architectural remnants of the city disappeared. By the time of Gayet’s excavations there was only a small mud-brick village called Sheik Abada at the site.

After each winter’s expedition to Egypt, the fabrics and artifacts—even mummies—were brought back to Paris for exhibitions by Gayet. His displays in Paris featured tunics, mantles, shawls, head coverings, leggings, shoes, socks, cushion covers, curtains, wall hangings, strips of precious silk, coats of cashmere, mummy portraits on linen, and woolen tapestry fragments decorated with flora, fauna, figures, geometric motifs, and narrative vignettes in polychrome and monochrome palettes. He presented lectures with dancers dressed in faux Coptic garments. During the Paris Exposition Universelle de 1900, Gayet displayed textiles at the Palais du Costume in “sensational tableaux.” The costume exhibit was for the “glorification of feminine fashion from the nineteenth century back through history to the Late Antique world.” In 1901 Gayet became a celebrity for his discovery of the mummy of Thaïs, a legendary fourth-century converted courtesan and popular heroine of Anatole France’s 1890 novel and Jules Massenet’s 1894 opera. Gayet estimated that he had uncovered forty thousand graves by 1902.

Eventually the Gayet acquisitions were doled out to the Musée du Louvre and other museums in France. Gayet collections are also in museums in Italy, Belgium, and Switzerland. Many Gayet textiles, sold to public and private collections, are now scattered around the world. Often early Islamic textiles are included in Coptic collections. No radical difference in the way cloth was made resulted from the political change, however, the iconography slowly segued toward the Islamic taste for non-representational art. Few of these early excavators preserved archaeological context or recorded sufficient documentation to accurately date the fabrics: clues in the cloth and design are all that remain.

### Coptic Fabrics

The dominant fiber of Egypt's ancient and late antique fabrics is flax. The common Coptic linen yarn is an s-spun single (yarn spun in a clockwise direction), but z-spun yarns (yarn spun in a counter-clockwise direction), single or plied, are used with certain tapestry styles considered late and perhaps Near Eastern. The typical woolen yarn used during the Coptic period is an s-spun single. Occasionally z-spun yarns, and—in rare instances—plied yarns of two colored strands spun together are found. Silk, imported as fiber or fabric, was a rarity in Egypt. Soft weft (crosswise yarns) fibers of cashmere are found on some imported garments. Cotton and ramie are reported in Coptic and early Islamic fabrics. Precious gold thread can be documented on two separate pieces in French collections.

Linen, which does not readily accept dyeing, is typically undyed: wool readily accepts dyestuffs. Every color of the rainbow can be found in Coptic cloth. Blues were from indigo and woad; yellows from saffron, pomegranate, sunberry, weld, broom, iron buff, and safflower; reds from alkanet root, madder root, kermes, henna, and lac-dye; and purples from lichens and from the glands of shellfish of the *Purpuridae* family. The accepted theory among Coptic scholars is that wools were dyed in the fleece prior to spinning.

Horizontal ground-staked looms and upright vertical looms were in use in New Kingdom Egypt. The Alexandrian conquest brought warp-weighted looms to Egypt, but they were not extensively used. Pit-looms and upright Roman looms may have been used. There are tablet-woven textiles and sets of tablets that were discovered in Antinoé. Some type of loom with a pattern-making device, a precursor of the drawloom, was in use during the Coptic Period. The one-piece tunics so common in Coptic Egypt must have been woven on looms eight or nine feet wide.

Many types of fabrics were found in Coptic burial grounds: tabby or plain weaves, plaid tabby weaves, tapestries, tabby-tapestries, extended tabby or basket weaves, weft-loop weaves, warp-loop weaves, brocades, tapestries, taquetés (weft-faced compound tabbies), and samitums (weft-faced compound twills), resist-dyed tex-

tiles, warp-faced tablet weaves, sprang, knits, and some embroideries. Weaving was a guild or government controlled industry, but also always a cottage craft. The technical skills and artistry ranged from the rustic to the sophisticated and sublime.

There came into fashion in the late Augustinian age a "smooth cloth with woolen decorations." This is the quintessential cloth of Coptic Egypt, a combination tabby-tapestry (inserted tapestry) weave used for tunics, shawls, curtains, cushion covers, and large wall hangings. The basic fabric is a slightly warp-dominant tabby of linen warp and weft with an average sett of 56 ends per inch. The tapestry decorations are woven on the same linen warp with dyed woolen and ecru linen wefts. The transition from tabby to tapestry is typically achieved by grouping the warp in sets of two or more. This changes the average sett to 28/2 ends per inch and allows the weft yarns to pack down and completely cover the warp. Tapestry at this sett has a soft and wearable handle, not like the heavy, dense fabric of kilim rugs or medieval wall hangings.

Scholars believe that tapestry weaving came to Egypt with the Greek colonists. The tapestries of Coptic Egypt range in size from mere shreds of warp and weft to wall hangings nine yards long with nearly life-size figures. There are all wool tapestries as well as those of linen and wool. Weavers knew traditional methods of dealing with slits and joins. Early polychrome tapestries shade and blend color areas, while later pieces have separate segments of bold color. Some special techniques were used on the monochrome tapestries. Silhouette-style figures in white linen or dark wool yarn were woven on a mid-value background with a supplementary sketching-weft defining features on the tapestry faces and figures and patterns on a tapestry field.

### Coptic Costume

The common costume of Coptic Egypt—as ubiquitous as blue jeans are in the early 2000s—was a tunic with tapestry embellishment. The one-piece tunic of tabby-tapestry was woven from cuff-to-cuff on a hem-to-hem loom width with a slit for the neck opening. To finish the garment the fabric is folded at the shoulder line and seamed up the sides. Some tunics were woven in sections on a narrow loom and then pieced together. Tapestry cuff bands, shoulder or knee medallions, yoke panels, hem bands, and clavi (weft-wise bands) decorate the tunics. The clavi, which become the vertical strips of tapestry running down the front and back of the tunic, can be recognized as an early twenty-first century priestly stole. Men's decorations were typically monochrome, while the women's were often polychrome. Though there are variations in the size and arrangement of tapestry embellishments, the tunic stays in style for nearly a thousand years. Precious tapestry remnants were recycled and appliquéd on other tunics. Brocaded bands, tablet-woven bands, scraps of patterned taqueté or samitum, and some



separately woven tapestry bands were sewn to tunics. All wool tunics, decorated with tapestry and some with hoods, were also found. In frescoes, mosaics, and both secular and sacred manuscript illustrations from the early medieval world one can identify the same type of cloth and costume found in the necropolis of Coptic Egypt.

The *Antinoé Riding Coat* is an elegant knee-length coat nipped in at the waist with long flaring sleeves. Though found in Antinoé, they are considered Near Eastern. The coats of wool or cashmere were dyed a luscious red or blue-green. Scraps of delicately patterned silk samitums—the first draw-loom fabrics found in the western world—were used as facings and trim on these garments.

Shawls of linen tabby-tapestry textiles decorated with lavishly colored flowers, dyed woolen shawls, and perhaps silk scarves for the wealthy were worn over tunics. Patterned taqueté woolens, that Gayet found used as duvet covers, were probably reused mantle fabrics. Tapestry leggings, knit socks, leather mules embossed with gilt, and leather sandals with perforated straps were all found in Coptic graves. Hairnets of sprang, as well as bags, made of linen or linen and wool were a fashion item of the day. A *bourrelet de chenille* is an unusual women's head ornament worn to frame the face. A *bourrelet* is a roll of material and *chenille* is French for caterpillar—an apt description for this fuzzy roll of multicolored, long woolen weft-loops on a linen fabric. This is illustrated in Gayet's book wearing a *bourrelet de chenille*.

Gayet's many exhibits of Antinoé textiles—especially the one he created for the Palais du Costume at the Paris exposition of 1900—inspired costumes for opera, theater, silent films, and even a haute couture gown by Mariano Fortuny. Embroiderers could find Coptic patterns in three booklets published by Dollfus-Meig Company. Rodin collected Coptic textiles. Matisse and other Fauve artists, fascinated by Coptic tapestry art, discovered a new way of interpreting color, shape, and archaic scenes. The impact of Coptic textiles continues with new excavations, exhibitions, and publications.

Gayet believed that the exploration of Antinoé was “. . . the resurrection of a lost world” and the artifacts “. . . of inestimable value for the history of art.” His dream of an Antinoé museum was never realized, but the textiles discovered by Gayet—once quotidian cloth—grace modern galleries of museums around the globe. The diverse textile themes, techniques, and technology reflect influences from the languishing classical, flourishing Christian, and emerging Islamic world.

See also **Dyes, Natural; Loom; Textiles, Byzantine; Weave Types.**

#### BIBLIOGRAPHY

Du Bourguet, Pierre. *Musée National du Louvre Catalogue des étoffes coptes*. Paris: Editions des Musée Nationaux, Ministère d'Etat-Affaires Culturelles, 1964.

Hoskins, Nancy Arthur. *The Coptic Tapestry Albums and the Archaeologist of Antinoé, Albert Gayet*. Eugene, Ore.: Skein Publications in association with the University of Washington Press, 2003.

Lorquin, Alexandra. *Étoffes égyptiennes de l'Antiquité tardive du musée Georges-Labit*. Toulouse: Somogy Editions d'Art, 1999.

Martiniani-Reber, Marielle. *Soieries sassanides, coptes et byzantines V–XI siècles*. Paris: Editions de la Reunion des Musées Nationaux, 1986.

Rutschowskaya, M. H. *Coptic Fabrics*. Paris: Musée du Louvre, 1990.

Santrot, Marie-Hélène, M. H. Rutschowskaya, Dominique Bénazeth, and Cécile Giroire. *Au Fil du Nil: couleurs de l'Égypte chrétienne*. Paris: Somogy Éditions D'Art, 2001.

Trilling, James. *The Roman Heritage, Textiles from Egypt and the Eastern Mediterranean 300 to 600 A.D.* Washington, D.C.: The Textile Museum, 1982.

Nancy Arthur Hoskins

**TEXTILES, JAPANESE** Textiles have long played an important role in Japanese life. Japanese weavers and dyers used silk, hemp, ramie, cotton and other fibers, and a range of weaves and decorative treatments, to produce textiles of distinctive design and exceptional aesthetic merit. These textiles were put to many different uses: for clothing of both commoners and elites; for banners, hangings, and other materials produced for use in temples; for theatrical costumes; and for cushion covers, curtains, and other domestic uses. As with many other Japanese arts, Japanese textiles historically have developed through an interaction of external influences and indigenous techniques and design choices, and a tendency to develop both technology and aesthetics to a high degree of refinement.

#### Historical Overview

The original inhabitants of Japan (people of the Jōmon Culture) wove cloth of plant fiber. Invaders from the northeast Asian mainland established the Yayoi Culture in Japan beginning around 300 B.C.E., introducing more sophisticated materials (including ramie and silk) and techniques. But a recognizably Japanese textile culture can be said to have begun in the Yamato Period (c. 300–710 C.E.), when aristocratic clans and the emergent monarchy led to a greatly increased demand for fine fabrics, especially of silk. The introduction of Buddhism in the mid-sixth century swelled the demand for fine textiles for ecclesiastical use. Some of these textiles were imported from mainland Asia, but increasing amounts were produced in Japan. Weavers, dyers and other textile workers from Korea and China were encouraged to settle in Japan under court patronage; the production of textiles was both patronized and regulated by the state, and the best textiles were produced in imperial workshops.

Silk fabrics in both plain and twill weave were often dyed in solid colors or in patterns produced by stamped wax-resist dyeing. Brocades were produced for both aristocratic and temple use. Other techniques included appliqué, embroidery, and braiding.

The explosive growth in the number, wealth, and power of Buddhist temples in the Nara Period (710–785) led to an intensified development of textile arts, as well as the importation of mainland textiles on a massive scale. The ensuing Heian Period (795–1185) saw a greater emphasis on domestic production, partly in imperial workshops and partly in private ones. This period saw the continued importance of brocade and embroidery, along with increased use of pattern-woven cloth as a ground for patterned dyeing, whether done by wax- or paste-resist methods or various techniques of shaped-resist dyeing. As the harmonious use of colors in multiple layers of clothing was one of the chief aesthetic principles of dress in this era, great efforts were made to expand and perfect dyeing methods.

The Kamakura (1185–1233) and Muromachi (1338–1477) periods saw the establishment of military rule under the auspices of the samurai (warrior) class. International trade increased again during this period, bringing a wealth of new materials, techniques and design motifs to Japan. Cotton was introduced at this time, largely supplanting the use of hemp fiber in textiles used by commoners. The development of the Nôh theater under the patronage of the military aristocracy during the Muromachi Period, with its attendant demand for luxurious and brilliantly beautiful costumes, stimulated textile production and innovation. The introduction of multi-harness looms and improved drawlooms led to an increase in production of complex silk fabrics such as damask and satin, which often were used as background fabrics for patterned dyeing (damask) and for embroidery (satin).

After more than a century of civil warfare (1477–1601), the establishment of the Tokugawa Shogunate (1601–1868) brought an era of renewed peace and prosperity to Japan. By the sixteenth century the *kosode* had become established as the basic garment of Japanese dress; the rapid growth of cities, and of well-to-do urban populations, made this and ensuing forms of the kimono a focus for textile arts. Sumptuary laws designed to prevent commoners from wearing brocades and other complex textiles simply stimulated weavers and dyers to produce surface-decorated fabrics of exceptional beauty and variety that stayed within the letter of the law. The growth of urban pleasure quarters inhabited by courtesans who sometimes could command gifts of great value stimulated the brocade-weaving and tapestry-weaving industries, as demand grew for elaborate and luxurious sashes (*obi*) with which women fastened their kimonos. Meanwhile, in the countryside, peasants were establishing or maintaining their own techniques for weaving and dyeing cotton fabrics, often in distinctive regional styles.

The abolition of military government and the restoration of imperial rule in 1868 led to a period of rapid modernization in Japan. There was a significant vogue in the late 19th century for Western clothing for both men and women; in the early twentieth century, however, many women returned to wearing kimonos much of the time. Following World War II, kimono wearing declined again, becoming limited by the 1960s almost entirely to festival and special-occasion dress, or occupational dress for women in the hospitality industries. The traditional textile arts had already entered a long period of decline by the late nineteenth century, when Japan turned to the industrial production of textiles as an early step toward economic development and modernization. Cheap machine-made fabrics cut deeply into the peasant production of handwoven and hand dyed cotton cloth. Conscious efforts to maintain or revive old textile traditions has kept many techniques from disappearing entirely, but the hand production of textiles in Japan now belongs almost entirely to the world of art and craft.

### Woven Textiles

The weave types most commonly encountered in Japanese textiles, regardless of the fiber used, are plain (tabby) weave, twill weave, satin, damask and other patterned weaves, and brocade.

Silk fabrics intended for use in kimono in which the principal decorative elements are batch-dyed or resist-dyed rather than woven or embroidered are usually made in plain weave or damask weave. Colored damasks (*donsu*) employing dyed silk warp threads and weft threads in contrasting colors were used without further dyeing or embellishment; colored damasks were particularly favored for decorative purposes, such as mounting fabric for scroll paintings, and in cloths employed in the tea ceremony. Floating-weft or floating-warp satin (*sbusu*) is often used for silk garment fabrics in which the main decorative elements will be applied by embroidery. Patterned twill (*aya*) and twisted-warp gauze (*ra*), often in lightweight, semi-transparent fabrics, have been used for garments since the Nara period, and in later times were especially favored for the wide, loose trousers (*bakama*) and stiff jackets (*kamishimo*) worn by samurai on formal occasions. Twill is frequently also used as the ground weave for a multicolored, brocade-like, drawloom-woven fabric called *nishiki*.

Brocades and tapestry weaves of various kinds were used in ancient times for Buddhist ecclesiastical garments and temple decorations. As garment fabrics they are used especially in obi sashes, which are often tied in very elaborate and decorative ways that display to good effect the luxurious textiles of which they are made. Both obi and kimono, the latter particularly as costumes for Nôh dance-drama, are often made of *kara-ori* ("Chinese weave," i.e. weft-float brocade), a stiff, heavy fabric in which supplementary weft threads on bobbins are float-woven by hand over a plain or twill background fabric.

Fingernail tapestry (*tsuzure*), as the name suggests, is a bobbin-woven tapestry, capable of producing patterns of extreme complexity, and often used for obi.

Plain weave is by far the commonest weave for cotton fabrics. Rural, or faux-rustic, cotton textiles in stripes and plaids of indigo and other vegetable-dye colors, were extremely popular during the Tokugawa period for informal kimono; such fabrics were also used for domestic décor such as covers for sleeping mats and sitting cushions. Plain-woven textiles of plain white cotton were used as the ground for a wide range of dyeing techniques, described below.

### Dyeing

Much of the distinctive beauty of Japanese textiles rests on the use of highly developed techniques of dyeing, including paste-resist, shaped-resist, and ikat, as well as composite techniques employing two or more of these methods in concert.

Wax-resist dyeing (*batik*) was known in ancient Japan, but was abandoned by the end of the Heian Period in favor of paste-resist methods, employing a thick paste of rice flour instead of wax. Paste-resist methods include stencil dyeing and freehand dyeing.

Stencil dyeing (*katazome*) employs stencils made of mulberry bark paper, laminated in several layers with persimmon juice and toughened and waterproofed by smoking. Patterns are cut into these stencils using special knives. Paste is forced through the openwork of the stencil onto the cloth, where it then resists taking the dye when the cloth is immersed in a dyebath. The paste is washed from the cloth after dyeing. Simple stencil dyeing is most commonly found in folk-art indigo-dyed cotton textiles, used for domestic furnishings as well as for clothing. The most common contemporary application of paste-resist dyed indigo-and-white cotton cloth is for *yukata*, cotton kimono used as sleepwear and for informal streetwear, especially at hot spring resorts. Stencil dyeing can also be done in two or more stages to produce a multi-colored result.

Freehand paste-resist dyeing (*tsutsugaki*) uses a waterproof paper cone to apply paste to the fabric; this technique is often employed to create large, bold patterns such as are found on shop curtains (*noren*) and package-carrying cloths (*furoshiki*).

Shaped-resist dyeing techniques are generically known as *shibori* in Japanese; the word is commonly translated “tie-dyed,” but that does not convey the very wide range of techniques involved in *shibori* dyeing. *Shibori* includes resists created by sewing portions of cloth in tight gathers; or by twisting cloth, often in complicated ways; or by folding cloth and then compressing it between boards or in wooden or paper tubes; and similar techniques. In every case the aim is to compress portions of cloth so that they will be unaffected by the dye when the whole cloth is placed in a dyebath. Although expert prac-

tioners can achieve a high degree of control over the process, *shibori* dyeing always also includes some element of accident or uncertainty, which adds to its aesthetic appeal. Undyed areas of *shibori* textiles can be embellished in various ways, including hand-application of dyes using brushes, embroidery, or by using paste to apply gold or silver foil to the fabric.

Ikat, known as *kasuri* in Japanese, is a technique in which warp yarns, weft yarns, or both are bound in thread in pre-arranged patterns and dyed. The yarns are then assembled into a warp and/or woven as weft in the proper sequence, the pattern emerging as the weaving progresses. *Kasuri* textiles are produced in silk, in a wide range of colors; in ramie; in cotton, typically indigo-dyed; and in Okinawa in banana fiber, often with several colors produced by successive wrappings and dyeings of the yarn.

*Yuzen*, invented around 1700, is probably the most famous of Japanese dyeing techniques. It is produced by a combination of either freehand or stenciled paste-resist work and hand-application of dyes. With the cloth (either silk or cotton) stretched on a frame, a pattern is applied with a fine brush using a non-permanent blue vegetable dye, and then covered freehand with paste; or else the paste is applied directly with a stencil. A thin soybean extract is then brushed over the entire cloth. The cloth is then moistened with water, and dye is applied by hand with brushes; the dye spreads on the damp cloth to produce the color-shaded effect characteristic of *yuzen*. *Yuzen* is capable of achieving color effects of astonishing subtlety and complexity, and is used to produce the finest and most prized of all kimono fabrics.

The Okinawan art of *bingata* stencil dyeing can be thought of as a paste-resist version of batik. It uses multiple steps of stencil-applied paste and dyeing (either by vat dyeing or by hand application of dyes), with dyed areas covered with paste resist in subsequent stages of work. *Bingata* is typically produced in bright colors and with pictorial motifs of birds, flowers, and landscapes.

### Embroidery

Like brocade and tapestry weaving, embroidery arrived in Japan in ancient times in connection with Buddhism, and was often used to produce pictorial hangings for use in temples. Japanese embroidery uses a fairly small repertoire of stitches, including French knots, chain stitch, satin stitch, and couched satin stitch. In garments, particularly kimono, embroidery is applied to vat-dyed plain weave silk textiles, to silk satin, and as an embellishment to textiles decorated with various dye techniques, including *shibori* and *katazome*.

### Decorative Stitching

Japanese farm women developed a technique for salvaging worn cotton textiles for re-use by stitching them together in layers for use in jackets, aprons, and other protective garments. The technique, akin to quilting, is



known as *sashiko*, and developed from a practical way of using cloth to a unique craft of decorative stitching. *Sashiko* is almost always done with white cotton thread on indigo-dyed cotton cloth. Stitches may run parallel to the warp, or to the weft, or both; patterns are usually geometric, and often elaborately lacy.

### Ainu Textiles

The Ainu are the aboriginal inhabitants of Hokkaido, the northernmost main island of Japan; their ancestors were among the original occupants of Japan, prior to the arrival of the Yayoi people. Ainu culture is closer to that of Sakhalin Island and other parts of northeastern Siberia than it is to Japanese culture. The Ainu are known for preserving old techniques of making jackets and other items of clothing decorated with appliqué and embroidery in bold, curvilinear designs, often in light colors on a dark background.

### Contemporary Japanese Textiles

The status of textiles in contemporary Japan can be considered in four categories. *Commercial textiles* are a declining industry in Japan. Textile production, particularly of man-made fiber textiles such as rayon and polyester, played an important role in Japan's postwar economic recovery, but has been in decline in recent decades as production has moved to countries with lower labor costs. Some silk is produced in Japan by the country's heavily subsidized agricultural sector.

*Traditional textiles* continue to flourish. The Japanese government encourages the preservation of traditional arts and crafts through subsidies to "Holders of Important Intangible Cultural Properties," colloquially known as "Living National Treasures." These master practitioners of their arts provide leadership to thousands of other full-time craft workers. Of approximately 100 Living National Treasures at any time, about one-third are in the field of textile arts. Notable examples include brocade weaver Kitagawa Hyôji, the late stencil paste-resist dyer Serizawa Keisuke, and *yuzen* dyer Yamada Mitsugi.

*Fashion textiles* have received significant support from some of Japan's internationally famous fashion designers, notably Issey Miyake, whose innovative use of such material as tube-knitted jersey has bolstered Japan's fine textile industry.

*Art textiles*, or fiber arts more broadly, are a thriving field of Japan's contemporary art scene, and have achieved international recognition through such exhibitions as "Structure and Surface" (New York, 1999) and "Through the Surface" (London, 2004). A number of individual fiber artists have won international reputations, including Arai Junichi, known for his innovative use of techno-textiles; Sudo Reiko, known for her sculptural woven fabrics; and Tomita Jun, who uses traditional dyeing techniques to produce contemporary textile art.

See also **Dyeing; Embroidery; Ikat; Kimono; Yukata.**

### BIBLIOGRAPHY

- Dusenbury, Mary. "Textiles." In *The Kodansha Encyclopedia of Japan*. 9 vols. Tokyo: Kodansha International, 1983.
- McCarthy, Cara, and Matilda McQuaid. *Structure and Surface: Contemporary Japanese Textiles*. New York: Museum of Modern Art, 1999.
- Yang, Sunny, and Rochelle Narasin. *Textile Art of Japan*. Tokyo: Shufunotomo, 2000.

John S. Major

**TEXTILES, MIDDLE EASTERN** Even before the Islamic period, the Middle East was a nexus of Eurasian textile production and trade. The complex of trade routes commonly referred to as the Silk Road reached their western end at the ports of the eastern Mediterranean. Inevitably these markets were also centers of textile production. The spread of Islamic rule in the seventh and eighth centuries encompassed and incorporated the previous textile industries of the Byzantine and Sassanian Empires. In the early Islamic period textile design was derived from that of their predecessors, but Islamic cultures soon evolved their own forms of expression. During the Middle Ages, the textiles of the Middle East were highly prized goods that in due course stimulated the development of indigenous European production. The connection between Islamic and European cloth can be seen in the extensive textile terminology that is derived from Persian, Arabic, or Turkish, including terms such as damask, taffeta, cotton, muslin, seersucker, and mohair.

In the Islamic world, textiles were highly valued goods, accepted as tribute in lieu of taxes in some periods. Gifts of textiles and garments were presented to honor officials or visiting ambassadors. In a part of the world where much of the population could claim nomadic antecedents, interiors were primarily furnished with textiles, used to cover floors, walls, cushions, and to create beds and storage of all kinds. Gifts were presented in a textile wrapper, and the more elaborate the workmanship of the wrapper the greater the honor intended. Textiles were also held to have the power to protect or harm, and so inscriptions and symbols were frequently incorporated into them to this end. In the century following the death of Muhammad, representation of living creatures were banned, particularly in the Sunnī tradition. Islamic design developed its own metaphorical language, utilizing geometry, calligraphy, vegetal, and architectural forms. However, it should be pointed out that in some Islamic textiles human and animal figures do appear, particularly in Persian and Central Asian silks and carpets.

### Silk

Elaborately patterned silk textiles were produced throughout the Islamic world in various complex weaves, including compound twills, lampas, and brocades, as well as double and triple cloth. Motifs were stylized and var-

ied greatly depending on the period and region. Simpler textiles including *tafta* and satin weaves were also important and numerous, as were a variety of very light-weight silks. In addition, there were textiles in which silk warp and cotton weft were combined, frequently striped. In the rep weave known as *alaca* the silk warp (yarns stretched on the loom) covered the cotton weft (yarns interlaced with the warp) to produce an economical silk textile. In the satin weave known as *kutnu* the silk warp shows on the face of the fabric, but the back shows the cotton weft. This textile was widely favored because according to Islamic tradition men were forbidden to wear silk against the skin. Tapestry technique was another important category of silk weaving.

One of the most characteristic early Islamic silk textiles was *tiraz*, which was particularly important from the tenth to fourteenth centuries. It was a product of royal workshops. *Tiraz* textiles were embellished with borders containing inscriptions, usually embroidered or tapestry woven in gold thread. Baghdad was the best-known source of *tiraz*, but it was produced in workshops sponsored by many rulers in many locations from Egypt and Yemen to Syria and Moorish Spain. These borders appear most commonly as bands on the upper sleeve, but were also used on the edges or in the body of the garment. They were also found on burial shrouds and ceremonial textiles. The inscriptions usually included the name of the current ruler as well as religious quotations. *Tiraz* embellished garments were worn by high-court officials and presented as honorific robes. Linen or cotton textiles might also have *tiraz* bands.

The Moorish conquest of Spain beginning in the eighth century led to the introduction of *tiraz* workshops, as well as workshops for the production of compound-weave silk textiles. These silks might resemble the textiles of late Byzantine or Sassanian workshops, but soon Spanish workshops were producing distinctly Islamic motifs, including elaborate geometric designs as well as stylized floral designs. Spanish textiles were varied, but strongly contrasting colors and geometric motifs were common.

Bursa was the most important center for silk production in the Ottoman Empire from the fifteenth century on, although not the only producer of high-quality silk textiles. Ottoman silks were richly colored, and frequently featured large-scale patterns. Although in the fifteenth century Ottoman textiles could be said to have influenced Italian silk design, thereafter Italian design influenced some Ottoman silks. However, many designs were distinctively Turkish, showing an affinity with Ottoman miniature painting and tile design. These featured stylized flowers, foliage, and vines. A common motif was a cluster of three circles in combination with wavy lines. The Ottoman repertoire included voided velvet as well as other compound weaves. Fine silk embroidery, done on silk, velvet, linen, or cotton, was another important category of Ottoman textile work.

Safavid Iran produced exquisite silks that were considered to be among the finest in the Islamic world. Yazd in the fifteenth century and Isfahan and Kashan in the sixteenth and seventeenth centuries were among its most important centers of production. Elaborate voided velvets and a wide array of intricate compound weaves, as well as fine embroidery were characteristics of Persian silks. Persian designs were finely detailed with complex coloring. A distinctive group of Persian textiles used human and animal figures, done in the style of miniature painting. The most elaborate of these woven textiles included scenes from Persian literature. Silk embroidery was also an important category of Persian textiles. The fine quality of Persian silk fibers contributed to the high quality, and made Persian raw silk highly sought after by foreign merchants. Persian textiles also influenced Moghul India.

### Cotton and Linen

A variety of types of flax were raised in the Islamic world, as well as other types of bast fibers, including hemp. Both cotton and linen textiles were widely used throughout the region. These textiles ranged from the heavy cotton canvas produced for sailing ships to extremely fine muslins and gauzes. Although India is best known for fine cottons, all of the countries of the Levant also developed their own fine cotton weaving industries. However, trade with India for textiles was important for the entire Muslim world.

Textile printing was known in pre-Islamic Egypt, but dating and provenance of early Islamic printed textiles is generally not clear. Printing blocks have been identified from the Fatimid period, and a number of examples found in Mamluk Egypt are believed to have been produced there. By the sixteenth century a printing industry existed in Syria, and in the seventeenth and eighteenth century this industry expanded into Anatolia, stimulated by the expanding European demand for Indian printed textiles being transported through the Eastern Mediterranean ports.

### Mohair, Wool and Other Animal Fibers

Mohair and camel hair, as well as the goat hair referred to variously as cashmere or pashmina, were used to weave soft and beautifully patterned shawls in many locations throughout the Islamic world. These shawls became very popular in the west in the nineteenth century, but had long been a feature of dress in Muslim northern India, Persia, and Ottoman Turkey. The patterns were woven in twill tapestry or a variety of compound weaves, but in either case featured elaborately patterned and colored designs. Some of these were patterned stripes. Many were complex vegetal designs, the most well-known example of which is the *boteh*. The *boteh* is also referred to by other names depending on the language of the weaver. In the west this design came to be known as the paisley motif, named after Paisley, Scotland, where textile mills produced copies of the Indian shawls in the latter nineteenth century.



## GLOSSARY OF TECHNICAL TERMS

**Compound (twill, weave):** An adjective applied to any fabric or weave in which there are two or more sets of yarns in the lengthwise, the crosswise, or in both directions.

**Lampas:** Fabric with a woven figure in which crosswise yarns form the design and a second warp yarn holds the crosswise design-forming yarns in place.

**Tafta:** A fabric made from tightly twisted silk ply yarns in a plain weave.

**Rep weave:** Plain weave fabric in which crosswise yarns are larger than lengthwise yarns, thereby forming a pronounced crosswise rib.

**Tapestry weaving:** A handweaving technique in which crosswise (weft) yarns create a solid color patterned effect in selected areas (1) by being so closely packed that they completely hide the lengthwise (warp) yarns and (2) by not crossing the entire width of the fabric, but instead moving back and forth in the area of the design. In this way patterns of great complexity and size can be made.

**Voided velvet:** Velvet fabric in which the pile (standing fibers or loops) is limited to selected areas in order to form a design.

Although wool was widely used to produce a variety of apparel textiles, the best known Islamic wool textiles are the pile and flat woven textiles made as rugs, bags, bands, wall coverings, cushions, and other household equipment. Knotted pile weaving seems to have originated in Central Asia well before the date of the oldest known example, which was made about 2,500 years ago. The oldest examples of Islamic carpet weaving that have survived are the ninth century “Fostat” carpet fragment found in Cairo, and a group of thirteenth-century Seljuk Turkish fragments found in Konya in Central Anatolia. Sixteenth-century examples from Mamluk Egypt and Safavid Persia both attest to a sophisticated and long-established tradition. Carpet design can be divided into three categories that reflect their visual style, origins, and degree of technical excellence. The tribal carpets were produced by nomadic or village households primarily for their own use. The designs reflect tribal and regional affiliations, and tend to be relatively geometric in design. Although some are quite finely woven, many are relatively coarse. Court carpets were commissioned in court ateliers according to designs created by the finest artists of the day. These designs, which often bear a close relation to those of tile work, manuscript illumination, and silk textiles, are technically the most finely knotted, and visually the most intricate. Urban manufactory carpets constitute the third category. These carpets, produced under the direction of merchant entrepreneurs, may be technically very fine, but are characterized by somewhat more repetitive and less intricate designs as compared to court carpets.

Flat weaves include a variety of techniques, the best known of which include *kilim* (slit tapestry), *jajim* (compound discontinuous brocade), and *soumak* (warp wrapping). Card-weaving is a widespread method of making

bands that appears to have a long history of use throughout the Islamic world. These techniques and others are used to create floor and wall coverings, storage bags, tent bands, and door panels, as well as animal trappings. Generally flat woven wool textiles were produced primarily for local use and are characterized by distinctive tribal or regional designs and color palettes. Modern production, however, is increasingly tailored to the color and design preferences of western markets.

### Dyeing and Finishing

In the early twenty-first century much of this traditional production has been lost as modern textiles replace traditional ones. Where traditional textile production continues, the products are being transformed as the weavers seek to adapt to modern taste and lifestyles.

See also **Iran, History of Pre-Islamic Dress; Islamic Dress, Contemporary.**

### BIBLIOGRAPHY

- Baker, Patricia L. *Islamic Textiles*. London: British Museum Press, 1995.
- Eiland, Murray L. *Oriental Carpets: A Complete Guide*. Boston: Bulfinch Press, 1998.
- Fleet, Kate. *European and Islamic Trade in the Early Ottoman State: The Merchants of Genoa and Turkey*. Cambridge: Cambridge University Press, 1999.
- Kahlenberg, Mary Hunt. *Asian Costumes and Textiles from the Bosphorus to Fujiyama*. Milan: Skira, 2001.
- Harris, Jennifer, ed. *Textiles, 5000 Years: An International History and Illustrated Survey*. New York: Harry N. Abrams, 1993.
- Hull, Alastair, and Jose Wyhowska. *Kilim, The Complete Guide: History, Pattern, Technique, Identification*. New York: Chronicle Books, 2000.



Miller, Charlotte Jirousek. "Dyes in Rugs from the Milas Area." *Hali* 4, no. 3 (1982): 258–261.

Tezcan, Hülye. *The Topkapi Saray Museum: Costumes, Embroideries, and Other Textiles*. New York: Little, Brown and Company, 1986.

*Charlotte Jirousek*

**TEXTILES, PREHISTORIC** Textiles require long, pliable string-like elements. The earliest current evidence for human awareness and manufacture of string comes (as impressions on clay) from Pavlov, a Palaeolithic site of about 25,000 B.C.E. in the Czech Republic. Thin, breakable filaments of plant-bast fiber were twisted into longer, stronger threads yarns that were then twined as weft (crosswise yarns) around the warp (lengthwise yarns) and around each other to make net-like fabrics. These fabrics are sophisticated enough that this cannot be the very beginning of either thread-, yarn-, or net-making. Other slightly later finds, plus the fact that all human cultures know the art of making string, confirm that this technology began in the Palaeolithic and spread everywhere with the human race. Indeed, string-making probably made it possible for humans to spread into difficult eco-niches, since it improves hunting/fishing capabilities and enables food-packaging.

Interestingly, a few of the so-called Venus figures (hand-sized carvings of women, usually plump, dating to about 20,000 B.C.E. and found from France to Russia) wear garments clearly fashioned of string: string skirts, bandeaux, or netted caps. These garments seem to signal information about marital status.

The first proof of true weaving occurs circa 7000 B.C.E. at the start of the Neolithic, with impressions of plain-weave and basket-weave on clay at Jarmo (north-east Iraq) and a pseudomorph (minerals having outward characteristics of organic materials) of a plain-weave textile on a bone at Çayönü Tepesi (southern Turkey). Again, these fabrics are too well done to be the start of weaving. Over the next millennium, fragments and impressions of mats, baskets, and twined textiles are found scattered through Iraq, western Iran, Turkey, and the Levant. Sizable pieces of linen actually survived in a desert cave at Nahal Hemar, Israel, circa 6500 B.C.E.; one needle-netted piece adorned with stone buttons is apparently a ritual hat.

Around 6000 B.C.E., at Çatal Hüyük in central Turkey, there was such a preponderance of plain-weave over twining, among the many fragments of linens used to wrap ancestral bones, that one can conclude the heddle (mounted loop) that forms a harness to separate warp yarns in a loom had been invented. (True-weave fabrics ravel easily, unlike twined ones, so the only advantage to



### GLOSSARY OF TECHNICAL TERMS

**Bast fiber:** Fiber that is obtained from the stem of a plant. Examples include linen from the flax plant, ramie, and hemp.

**Heddle:** Device on a loom through which each lengthwise yarn (warp yarn) is threaded that allows warps to be raised and lowered during weaving.

**Kemp:** Straight, short, stiff, silvery white fibers in wool fleece that do not spin or dye well.

**Kermes:** Natural red dye used since ancient times that is made from the eggs obtained by crushing the bodies of a tiny female insect parasite found on oak trees.

**Overshot:** A type of weaving in which an additional set of crosswise yarns extend across two or more lengthwise yarns in a plain background weave to form a pattern or design. Pile fabric surface on which fibers, yarns, or raised loops that may be cut or uncut or stand up on the surface of a background fabric.

**Pseudomorph:** When used in reference to textile evidence found in archeological sites, a mineralized imprint of textile yarns or fabrics.

**Selvage:** The lengthwise edge of a woven fabric that is often made with heavier yarns and woven more tightly than the rest of the fabric in order to make this area strong and secure.

**Shed bar:** Rod or stick on a primitive loom that is used to separate one set of lengthwise (warp) yarns from another set so a space (called the shed) is made that allows the passage of the crosswise (weft) yarns.

**Supplementary weft:** An extra crosswise yarn, in addition to the primary crosswise yarn.

**Warp/warp yarn:** Lengthwise yarns in a woven fabric.

**Weft/weft yarn:** Crosswise yarns in a woven fabric.

**Woad:** Natural blue dye obtained by fermenting the leaves of the woad plant, *Isatis Tinctoria*.



**Egyptian textile workers depicted in funerary model.** Though only women are seen here, ancient Egypt differed from other early civilizations in that both men and women wove the favored white linen. THE METROPOLITAN MUSEUM OF ART, PHOTOGRAPH BY EGYPTIAN EXPEDITION, 1919–1920. REPRODUCED BY PERMISSION.

true weave is that the process, unlike twining, can be mechanized with shed bars and heddles. So once the heddle—a conceptually difficult invention—is available, weaving ousts twining thanks to the speed of manufacture.) This corpus includes tied fringes, reinforced selvages (closed edges of a fabric that prevent unraveling), rolled and whipped hems, weft twining and warp-wrapped twining, as well as coarse, fine, tightly- and loosely-woven fabrics.

With the heddle invented and domestic flax available, large-scale weaving began to spread in all directions. In Europe have been found remains of vertical warp-weighted looms in villages around the central Danube by 5500 B.C.E., a tradition reaching the Swiss pile-dwellings by 3000 B.C.E. as it spread west and north. By 5000 B.C.E. crude linen-weaving spread south to Egypt, where someone painted the first known depiction of a loom circa 4200 B.C.E. Weaving with heddles also spread eastward across Eurasia, apparently reaching Tibet and China circa 5000 B.C.E.

Inhabitants of the western hemisphere probably invented twined fabrics on their own (unless, like string, this technology entered with them); the earliest finds date

to about 8000 B.C.E. But true weave does not appear until nearly 2000 B.C.E., radiating from an area of north-west South America containing both archaeological and linguistic evidence that some Asiatic foreigners had somehow arrived. That suggests that the heddle was invented only once, in either the northwestern Near East or southeastern Europe, some time before 7000 B.C.E., and spread worldwide from there.

Despite the subsistence-level economy of the Swiss pile-dwellers and their neighbors, central and western Europe is the one area where there is evidence of decorative patterning in Neolithic textiles: supplementary weft and occasionally warp patterns (both overshot and brocaded), beading (with seeds), an example of the Log Cabin (color-and-weave) pattern, and what may be embroidery (the originals were lost in one of the wars—only drawings survived). All these textiles were too blackened to show color, but the investigator of the most ornate claimed that it would not have been made that way unless the weaver were juggling at least three colors. A Neolithic site in France produced evidence of dyeing thread yarn with both kermes (red) and woad (blue), both colorfast dyes. Other evidence for patterning comes from clay figurines of women found in the Balkans and Ukraine: Many are naked and some wear string skirts, but others wear simple wraparound skirts with a square or checked pattern.

Up to 4000 B.C.E., the only readily available fibers came from plant stems (bast fibers: flax around the Mediterranean; hemp farther north across Eurasia, including China; yucca, maguey, among others in the western hemisphere). Sheep (*Ovis orientalis*) had been domesticated in the Near East around 8000 B.C.E., but for meat—their coats consisted primarily of bristly kemp, with only a short undercoat of ultra-fine wool (5 microns) for insulation. “Nice” modern wool runs 15 to 30 microns in diameter, but the wild kemp runs about 300 microns and has no torsional strength, so it cannot be twisted into yarn. It appears to have taken 4000 years of inbreeding to develop sheep with usable amounts of wool in their coats (genetic changes gradually eliminated the kemp, while the wool grew longer and heavier). Once woolly sheep were available, however, everyone wanted them and soon they were taken to Europe and the Eurasian grasslands. Unlike bast, moreover, the wool of even a single sheep typically includes several shades of color, which can be sorted for patterning one’s cloth. This helped fuel the explosion of textile technology in the next era.

### Bronze Age

It is only as people began experimenting with metals, shortly before 3000 B.C.E., that they seem to have begun using cloth widely, and in particular to differentiate themselves with clothing. Since metals had to be obtained through trade or distant mining expeditions, people began moving around much more, causing new concentrations of wealth and greatly increased movement of ideas.

A tall stone vase from Uruk (the Mesopotamian city in which writing first appeared about this time) shows the key domesticates—grain and sheep—in the bottom registers, with lines of naked workers bringing in the harvest above them, while in the top register we see the fancily dressed elite presenting gifts of food to a fully clothed goddess or priestess. As in the Palaeolithic, clothing developed—as seen here—primarily to send social messages, becoming ever more elaborate in both the Near East and Europe.

Neither textiles nor paintings survive well in the Near East, but cuneiform texts attest to the importance of textiles. We see this particularly in the dowry lists of young women, with their chests of clothing (and numerous hats), in the high prices fetched by some textiles, and also in some women's letters (about 1800 B.C.E.) concerning textile manufacture. In one group, two queens, good friends, discuss their woes in overseeing the palace manufacture (by slave women) of fancy cloth and clothing that their husbands expect to use as important diplomatic gifts. In another set, a group of merchant-class women in Assyria, who were in business for themselves making and selling textiles, discuss and argue with their far-faraway husbands (who sold the textiles abroad) about types of cloth to make, prompt payment, tax-dodging, opportunistic purchases, and problems with the caravan-drivers who transported the goods. Textile manufacture, in fact, was basically women's work in early times, as shown by the representations (which generally show women doing the spinning and weaving) and the location of textile tools in women's graves, not men's. Men, however, often helped with fiber production, felting or fulling, dyeing, and final sale (although much cloth was made for the family itself).

In Egypt, however, many matters differed. Traditionally women spun thread and wove it into cloth, but men also spun, making the string and rope needed in the fields; and mat-weaving was men's work. In the murals, we see children learning to spin beside their mothers in the textile workshops. Men also did the laundry, which had to be done in the Nile where crocodile attacks were a problem. Archaeologists have found linens of all grades, from coarse sailcloth to pieces as fine as silk handkerchiefs (200 threads per inch). Unlike their northern neighbors, the Egyptians wore mostly only white linen, since they preferred to have clean, bleached clothes every day (Egypt is very dusty and linen is wonderfully wash-and-wear, unlike wool); for color they used beads and other jewelry, instead of patterned cloth. Since textiles are preserved far better in Egypt than most other places, people tend to think everyone "back then" wore only white cloth, which is not true.

The glory of Bronze Age weaving designs is most visible in the frescoes of Minoan Crete, where we see women in particular arrayed in sophisticated polychrome patterns, especially running spirals, three- and four-

petaled interlocks, and small all-over patterns closely reminiscent of twill and rosepath designs. The men wore simple loincloths with fancy woven edgings, but the women wore long flounced skirts and tight-fitting short-sleeved bodices and sashes sewn up from these elaborately patterned cloths. For a millennium (c. 2100–1200 B.C.E.), Aegean weavers even exported large, brightly patterned cloths to the Egyptians, who apparently coveted them for making ostentatious canopies. For actual color, some Bronze Age textiles of Central Asia have preserved stunning reds, blues, and yellows.

As the Bronze Age progressed, the Mesopotamians, Minoans, and Egyptians all began importing ornate textiles from Syria, which seems from its texts to have been an important center of the industry. (Textiles themselves do not survive there.) Around 1475 B.C.E., Egypt even imported both tapestry technique and the "tapestry loom" (vertical two-beam loom) from Syria, where both seem to have begun a millennium earlier. By 1200 B.C.E., Egyptians depict Syrian and Aegean captives as wearing extremely ornate clothing characterized by friezes of animals. This tradition of friezed textiles seems to have survived in Greece through the period of destructive attacks that ended the Bronze Age around 1200 B.C.E., resurfacing there about 800 B.C.E., where, in being copied onto Iron Age Geometric and Wild Goat styles of pottery, it jump-started Greek art.

### Other Areas

In India, cotton was domesticated before 3000 B.C.E., but it reached the Mediterranean only after 1000 B.C.E. Cotton is easy to dye, and the Bronze Age city-dwellers of the Indus valley apparently exploited this trait, judging by the dye-installations and occasional depictions. In northern China, people discovered silk by 2000 B.C.E., developing its production, dyeing, and weaving into a high art—and a royal monopoly—during the great Shang dynasty (1500–1100 B.C.E.). Unfortunately, little but pseudomorphs has survived from periods before the mid-first millennium B.C.E.

True weaving was well developed in the Andes and in Central America before Europeans arrived. The Andean people had available not only cotton (native to both New and Old Worlds) but also the wool from alpacas, which occurs in a wide variety of shades from white through soft browns to black. Many superbly crafted pieces of tapestry and embroidery have survived, thanks to the cold, dry climate of the high Andes. Mayan and Aztec textiles have seldom survived, although we know from accounts and images that they were sometimes quite ornate. North of the "four-corners" area of the western United States, the heddle was still unknown. The one famous type of ornamented cloth from prehistoric North America, the Chilkat blanket, was laboriously twined onto a hanging but unweighted warp. (The Navajo did not start to weave their colorful blankets until the late nineteenth century.) The feathered garments of the



Hawaiian royalty, too, were made by twining, using the twist of the plant-fiber weft to bind in the brightly colored feathers.

See also **Dyes, Natural; Linen; Loom; Wool.**

#### BIBLIOGRAPHY

- Adovasio, J. M., Olga Soffer, and B. Klima. "Palaeolithic Fiber Technology: Data from Pavlov I, ca. 26,000 B.P." *Antiquity* 70 (1996): 526–534. Earliest preserved textile remains yet found.
- Barber, Elizabeth Wayland. *Prehistoric Textiles*. Princeton: Princeton University Press, 1991. Compendium of archaeological textile data from 20,000 B.C.E. to about 400 B.C.E., from Iran to Britain; technical history of early textiles. Massive index and bibliography.
- . *Women's Work: The First 20,000 Years*. New York: W. W. Norton and Company, 1994. Social and economic history of early cloth and clothing.
- . *The Mummies of Ürümchi*. New York: W. W. Norton and Company, 1999. Superbly preserved textile finds from prehistoric Central Asia.
- Burnham, Harold B. "Çatal Hüyük: The Textiles and Twined Fabrics." *Anatolian Studies* 15 (1965): 169–174. Preserved textiles from 6000 B.C.E.
- Cotte, J., and Ch. Cotte. "Le Kermès dans l'antiquité." *Revue archéologique* 7 (1918): 92–112. Neolithic fiber-dyes.
- Dalley, Stephanie. "Old Babylonian Dowries." *Iraq* 42 (1980): 53–74. What women wore in Mesopotamia 4,000 years ago.
- . *Mari and Karana*. London: Longman, 1984. Letters (often about textile work) of two Mesopotamian queens.
- Schick, Tamar. "Perishable Remains from the Nahal Hamar Cave." *Journal of the Israel Prehistoric Society* 19 (1986): 84–86 and 95–97. Preserved textiles from 6500 B.C.E.
- Schlabow, Karl. "Beiträge zur Erforschung der jungsteinzeitlichen und bronzzeitlichen Gewebetechnik." *Jahresschrift für mitteldeutsche Vorgeschichte* 43 (1959): 101–120. Patterned Neolithic textiles from Germany.
- Veenhof, Klaas R. *Aspects of Old Assyrian Trade and Its Terminology*. Leiden, Netherlands: E. J. Brill, 1972. Old Assyrian textile trade, including letters of women weavers.
- Vogt, Emil. *Geflechte und Gewebe der Steinzeit*. Basel: Verlag E. Birkhäuser, 1937. Full analysis of Neolithic Swiss lake-bed textiles, circa 3000 B.C.E.
- Welters, Linda, ed. *Folk Dress in Europe and Anatolia: Beliefs about Protection and Fertility*. Oxford and New York: Berg, 1999. Analysis of rural survivals of important (message-bearing) prehistoric designs in women's cloth and clothing.

E. J. W. Barber

**TEXTILES, SOUTH ASIAN** The large geographic region of South Asia consists of many diverse nations, each distinguished by their varied religions, geographic and climatic conditions, peoples, and diverse cultural, economic, and political and social dynamics. The countries that constitute South Asia are: Bangladesh, Bhutan, India, Maldives, Nepal, Pakistan, and Sri Lanka. (Tibet,

administratively an "autonomous region" of China, is also usually included.)

Throughout recorded history, textiles have played an important role in the social, cultural, and economic life of South Asia. Cotton, as well as many dye plants, is native to the Indian subcontinent, facilitating the development of many textile techniques. Distinctive dress forms evolved from lengths of unstitched cloth. Furthermore, much of this region lies along or occupies great historic sea and land trade routes whereby textile products were disseminated along with great cultural exchange and the spread of Buddhism, Hinduism, and Islam.

#### Bangladesh

Bangladesh historically occupied an important position linking trade between South and Southeast Asia. Its cottons were traded throughout Asia, Persia, and Africa. Once largely Buddhist and Hindu, beginning in the thirteenth century, the country became predominantly Muslim. Bengal (the region now divided between Bangladesh and India's West Bengal Province) was affected politically and economically by the arrival of the British East India Company in the eighteenth century, which led to increased religious, economic, and political polarization and class conflicts. East Bengal became independent (as East Pakistan) in 1947, and broke away to become the independent state of Bangladesh in 1971.

Bangladesh has long been famous for its high-quality woven cottons, silks, and jute production. Especially famous were the ultra-fine muslins of Dahka (or Dacca). Plain, striped, checked, and figured saris woven of fine muslin threads were often given poetic names to describe their cobweb-like lightness and softness. *Jamdanis* are figured cloths, where small images are woven or inlaid in an embroidery-like weaving technique called discontinuous supplementary weft. Equally famous silk brocade saris have also been woven in present-day Bangladesh.

In rural areas, there were varieties of tribal backstrap weavings formed into clothing. Two-piece clothing worn by women, consisted of the *mekhala*, or saronglike lower-body wrap, and the *riab*, or upper-body breast cloth. Women also wove and wore chaddar, or head cover/shawls. Men wore the dhoti, or loin cloth, a shoulder wrap and occasionally a simple untailed jacket stitched from several pieces of hand-loomed fabric.

The *kantha* is a famous embroidered textile from Bangladesh and Bengal. Made from layers of worn saris and dhotis, these thin blankets were embroidered with figures and scenes of everyday and religious life, then quilted in tiny white stitches. Although *kantha* vary in style and color scheme by region, a characteristic feature is a central lotus medallion.

#### Pakistan

Pakistan is an ancient land with a fascinating multicultural history. Remains of woven and dyed cottons have been

found among the third millennium B.C.E. Indus Valley settlements located in present-day Punjab and Sind regions.

Many ethnic and tribal groups of Pakistan wear slightly varying garments of vastly different names. There are numerous names for head covers, upper body garments, and lower. From the Sind area, a woman's embroidered headcloth is named *bochini* or *abocchnai*; in Punjab all-over embroidered headcloths in geometric patterns were *phulkari bagh* or *chope*, while the figured embroidered ones were called *sainchi*. Women generally wear three-piece sets consisting of drawstring-waisted *salwar* (sometimes spelled *shalwar*), long over-tunics variously called *kameez*, *pushk*, or *cholo*, and head covers. A long embroidered wedding blouse is called *guj* or *chola*, depending on the region and community. Men formerly wore the kurta, a collarless long-sleeved upper body garment over *salwar* drawstring trousers, or over the *lungi*, a sarong-style lower-body garment. In the twenty-first century, men typically wear Western-style trousers. The *malir*, or *bbet* or *bukhano* (depending on the community) was an important male wedding cloth that could be worn over the shoulder or as a turban. In cooler regions of both India and Pakistan, men wear an outer coat called *choga*.

### India

This vast landmass is home to numerous languages, religions, tribal groups, and diverse communities. Cotton is native to India, as are many dye plants including indigo and madder, and the cultures of India have produced exceptional skills and creativity in textile arts. Due to India's religions, social customs, textile skills and products, hereditary castes of crafts workers, and the role of women in producing dowry textiles, the textile arts and diverse forms of Indian dress are distinctive, impressive, numerous, and ancient. Specific forms of dress, employing characteristic textiles, were intricately intertwined with and dictated by factors such as region, urban or rural setting, caste and social station, ceremony or religious activity, and historical time period.

Trade, invasions, and imperialism brought many changes to Indian culture, including textiles and dress. The introduction of Islam beginning in the thirteenth century, and the establishment of the Delhi-based Mughal Empire in the sixteenth century, brought new types of fabric and new garments. Rich dress and splendid outward appearance was preferred, and the Mughals rewarded their administrators and loyal military staff with lavish dress. Simultaneously, in the fifteenth century, Europeans opened sea routes that challenged the long-standing routes of Arab traders who had heretofore monopolized the trade between Asia and Europe. The Portuguese established themselves in south India and made Goa the seat of their power and trade. The Dutch Netherlands East India Company understood the intrinsic aesthetic and symbolic value of Indian textiles and utilized them in exchange for spices with present-day Indonesia. Textiles played an important ritual role in

many of the diverse cultures of the East Indies islands, and so Indian trade textiles (for example, the silk ikat known as patola cloth) were in strong demand there. The British East India Company traded largely between India and England, and eventually established British domination of the subcontinent, exerting power in part through subservient local rulers. *Maharajas* (kings), *maharanis* (queens), and their Islamic counterparts, the *Nawabs*, demanded elaborate courtly dress to declare their elite status. These courts generated large demands for woven silks, gold and silver brocades, embroideries, and jewels. Wealthy merchants and traders also dressed in similar splendid style.

British rule in India, and its economic effects, had a profound impact on Indian-made cotton, textiles and clothing. Homespun thread and yarn was displaced by imported British factory-spun thread, while foreign markets for traditional Indian cotton trade goods, such as muslin and chintz, were also undercut by British manufacturing might and discriminatory trade rules. One tactic of Indian nationalist opposition to British rule in the early twentieth century sought to counter the domination of British mill-woven goods in favor of self-reliance through making and buying Indian *khaddar* (handspun, hand-loomed cottons) and other hand-made goods. Factors intrinsic to local culture also led to the preservation of many textile types and techniques.

In both India and Pakistan, marriages are occasions for the production of ceremonial and decorative textiles and special dress. In northwest India and twenty-first-century eastern Pakistan, textiles and dress are important items in the dowry that a bride brings to her new home. Brides' families prepared decorative textiles such as *torans* (doorway hangings), *chaklas* (decorative squares), *dbraniyo* (quilt covers), and quilts called *rilli* as part of the dowry. New clothing sets were also made, including the garments to be worn for the marriage ceremony.

Early records show that textiles were closely linked with ritual and purity, and early texts describe unisex upper- and lower-body garments of hand-loomed, wrapped cloth, as well as tailored garments. Woven cotton, wool and silk were commonly mentioned for clothing and trade. Ways of dressing by wrapping cloth is seen in ancient sculptures as well. The *dhoti*, or male lower garment, and loin cloth have been tied in similar fashion for thousands of years. In ancient India, the fibers, quality of a fabric, and the ornamentation materials and methods constituted a well-understood visual language to convey the status of the wearer. Garments woven with gold thread were referred to as *zari*, and if particularly heavily woven, they were called *kinkhab*. Tie dyed-garments were referred to as *bandanna* and diagonally tie-dyed clothing was called *laheria* for the specific designs resulting from the process.

Dress in traditional India varied greatly by climate and region, religious group, and community, and also by

fiber, method of construction, and type of imagery or ornamentation. Saris continue to be identified by regions of production and outstanding visual characteristics. An Indian woman can name countless regional weaves and describe the main characteristics of saris by their names, such as Baluchari Buttidar, Varanasi (heavily brocaded weaving, also called *benarasi*; common designs include the mango, moon, vines, and small flowers), Himroo, (brocaded weaves from the central Deccan area), and Patola (double ikat silk woven in Patan, Gujarat; designs consisting of repeated geometric grid-like patterns and striped borders), to name a few.

Forms of dress have evolved dramatically in India to reflect the dynamic social shifts that have occurred, as well as external influences, changing styles and influences of globalization through new styles, materials, economic development and attitudinal changes. Where urban women throughout India once wore the sari, by the 1970s many had adopted the Muslim and Punjabi style of dress consisting of *salwar* and *kameez* worn with a *dupatta*, a long head cover/shawl. In the mid-1980s, a movement called the “ethnic style” reflected a new interest in the aesthetics of rural embroideries, by applying commoditized embroidery elements to the bodice of the *kameez*. Combinations of embroideries from diverse groups with Indian-made fabrics like block print, recycled saris, or hand-loomed fabrics were sometimes styled into dress echoing contemporary Western styles. The dress of men in rural areas changed from wrapped lengths of cloth called the *dhoti*, or *lungbi*, to the wearing of trousers, and from loose upper body garments to more traditional western shirts. Many rural women shifted to wearing synthetic-fiber saris, which were cheaper and easier to care for and had a more contemporary association. By the 1990s, many urban women abandoned wearing saris and *salwar-kameez*, adopting instead casual, Western sportswear and wearing more traditional *salwar-kameez* or saris on special occasions.

### Sri Lanka

Sri Lanka, formerly known as Ceylon, is located in the Indian Ocean, southeast of the subcontinent of India. The textile arts of Sri Lanka are very similar to those of southern India. Rulers from the south brought artisans and established handicrafts production around 300 B.C.E. Indigenous weavers made primarily cotton goods, while the higher caste weavers of south Indian origin wove cloths with gold thread.

The indigenous population of the greater part of Sri Lanka is Sinhalese. Historically, Sinhalese women bared their breasts and wore white, or red or white with red-striped cotton lower garments that were draped like a dhoti, pleated and tied with a knot at the waist. When working, women bound their breasts with the *thanapatiya*, or breast bandage. Buddhist monks and nuns wear yellow, brownish, and maroon *kasaya*, or robes.

The Tamils of northeastern and eastern Sri Lanka dress in saris and Western dress, as do the people of Tamil Nadu in India. Sinhalese men are frequently bare-chested and wear checked cotton or synthetic sarongs. On formal occasions, men wear white shirts and European-style jackets. Contemporary women’s dress was greatly influenced by the Dutch as well, with the wearing of Javanese batiks and prints wrapped sarong-style and topped with long-sleeved, low-necked blouses.

### Maldives

The Maldives is a chain of small islands lying in the Indian Ocean off the southwestern coast of India. The earliest settlers of these lands immigrated from India and Sri Lanka perhaps more than 2,500 years ago. The Maldivians have long been fishers and traders. Maldivian cowry shells (which were widely used as currency in ancient times), coir fiber from coconuts, and fine cottons attracted trade with Arabs who first introduced the Islamic faith in the twelfth century. In the hot, humid climate of the Maldivian Islands, people traditionally were bare-breasted but wore lower body wrappers of very fine cotton. Men wore light-colored *lungbis* and women wore the saronglike garment called *feyli*, which was started below the navel and fell to the ankles.

In the seventeenth century, a devoutly Islamic sultan imposed regulations that women cover their breasts and wear *burugaa*, the Dhivehi word for burqa, Hijab, or veil. After several sultans’ rule, the women’s Islamic dress code disappeared and did not reemerge until the mid-1980s. Since this time, many Maldivian women have felt pressure to don the *burugaa*, and the issue of whether or not to wear Middle Eastern-style Islamic dress is hotly contested. On the main island of Malé, men wear Western-style clothing and many women wear dresses topped by shiny synthetic fabric overcoats and head scarves. For festive occasions, modern Maldivian “national dress” for men consists of a white shirt and light-colored check or plaid *lungbi*, and for women, a solid-colored dress trimmed with white accent bands at the skirt bottom.

### Nepal

Nepal is a Himalayan kingdom that unites numerous formerly independent principalities. The population is roughly divided into Tibeto-Burmans in the mountainous north, and Indo-Aryans in the southern lowlands; these populations are further divided into numerous ethnic groups, with many different cultures, languages, and religious beliefs. Nepal’s diverse climate and geography also yields diverse fibers ranging from yak hair in the north to sheep’s wool, silk, nettle, hemp fiber, and cotton in the tropical areas. While at one time people produced their own fibers and garments, barter trade with India and Tibet led to new sources of textile materials and ready-made clothes. In the early twenty-first century, hand-loomed fabrics have largely been replaced by ready-made garments and mill-woven goods.



Distinctive textiles of Nepal include *dhaka*, an inlaid tapestry-woven cloth used to make caps, or topis, and *rari*, thick, rain-proof woolen blankets made from several lengths of hand-loomed fabric. Although most traditional Nepalese textiles have been or are in danger of being displaced by manufactured imported fabrics, the demand for hand-loomed *dhaka* fabric, created on jacquard looms, remains high. There is also increasing interest in the hemp fiber clothing.

### Tibet

Tibet, the northernmost of the South Asian countries, occupies the northern slopes of the Himalayas and the high Tibetan plateau. Historically, Tibet has been largely isolated from foreign influences, but traded with China (as well as with India, via trans-Himalayan caravan routes). Consequently, numerous aspects of Chinese culture are visible through the silk weaves, images, symbols, and some basic garment forms throughout much of Tibet's textiles and dress. Generally Tibetan people wear long, side-closing robes called *phyu-pa* for the sleeveless type and *chupa* for the long-sleeved robes, long sleeveless vests, jackets, sashes, aprons, and hats, with long fleece coats and high boots in cold weather. Types and qualities of materials were dictated by (and proclaimed) the wearer's status in Tibet's once highly stratified society. Garments are made of brocaded silk, wool, cotton and fleeced-lined hide.

Pastoralists of both genders wear leather robes, with the fleece side against the skin. In hot weather, men pull the robes back over one or both shoulders and tie the sleeves at the waist. Sewn by men, these hide garments are called *lokbar*. Women's *lokbar* are frequently trimmed with colored cloth bands at hem and cuffs. Buddhist personnel wear garments with distinctive details to indicate hierarchy and roles. The shape of the hat distinguishes monastic orders. The Buddhist monk's common garment is called *kasaya*. The inner *kasaya* is yellow and the outer one is deep red/maroon. Worn in pairs, the large rectangular *kasaya* are topped with a cloak in the winter. High-ranking lamas wear yellow silk, often lotus flower-brocaded robes, embroidered vests, tall brocade boots, and golden hats appropriate to their station when traveling. Religious festivals, performances and ceremonies call for special dress, masks, and headgear.

Among the most distinctive Tibetan fabrics are those used in women's aprons, called *bangdian*, which consist of three or four parts stitched together. Rectangular and trapezoidal, these aprons are usually made of hand-woven cotton with contrasting color stripes.

Due to increased Chinese immigration into Tibet and sweeping social changes, the ancient hierarchical rules that once dictated rigid Tibetan forms of dress have disappeared. Globalization in the form of more readily available Chinese garments and mill-woven and brightly printed cottons has led to changes in dress. Frequently,

women in the early 2000s wear printed blouses under their *chuba* or *lokbar*, and urbanites generally prefer more subtle color schemes and streamlined silhouettes. In response to the flood of Chinese goods, many Tibetans are making efforts to not lose their traditional dress and weaving skills.

### Bhutan

Bhutan is a Himalayan Buddhist kingdom that historically has been linked through religion to its neighboring countries of India and Tibet and through trade to China. It has been and remains relatively isolated from the rest of the world. The population is diverse, including ethnic groups of Tibetan, Assamese, Burmese, and Nepalese affinities and significant numbers of Tibetan refugees and Nepalese immigrants. The dress of these groups varies, reflecting their distinctive cultural origins.

In Bhutan, textiles are symbolic of wealth. They serve functional and decorative purposes in the home, in religion and ritual, are given as offerings or gifts, and are made for dress. Women weave hand-woven textiles that often have complex striped warps, brocade weaves, and inlaid (or supplementary) weft patterns, while men tailor and embroider. Some of the supplementary weft patterns seen in Bhutanese weavings are similar to motifs also seen in Southeast Asian textiles. The chief fibers are silk, cotton, and wool, with synthetic fibers and colors now readily available. At one time, wealthy families produced their own spun and dyed fibers, but synthetic colors and mass-produced fibers have contributed to more colorful and rapidly changing fashion subtleties.

Although Bhutan is composed of many diverse populations with their own forms of dress, a national dress has been established to visually communicate unity. Bhutanese national dress for women is the *kira*, while the *gho*, or *go*, is the national dress for men. The *kira* is a large, hand-loomed rectangular cloth that is wrapped about the body and held in place with a *kera*, or belt and pins at the shoulders. A *kbenja*, blouse, and a slip, are worn under the *kira*, and the dress set is accompanied by a jacket and ceremonial shoulder cloth called *adba*. The blouse cuffs are folded over the jacket cuffs. Patterns and styles abound, each with specific descriptive names. *Gho* (or *go*), the male dress, is similar to the Tibetan *chuba* in that it is a tailored, long-sleeved, asymmetrical closing robe. However, the *gho* has large turned-back contrasting sleeve cuffs and is raised from the ground to just below the knees and held in place with a *kera*. Men wear knee-high socks and a *tego*, or shirt, under the *gho*. The folded-up portion at the waist of the *gho* serves as a multipurpose pouch. On special occasions, over the *gho* men wear a swag-like, ceremonial shoulder cloth called *kumney*. Other garments include three-panel woolen cloaks called *charkab* and *pangkheb*, or carrying cloths. Additionally, many forms of archaic dress survive for use in religious dances and festivals.

See also **Textiles, Southeast Asian Islands; Textiles, Southeast Asian Mainland.**

**BIBLIOGRAPHY**

- Askari, Nasreen, and Rosemary Crill. *Colours of the Indus*. London: V & A Publications, 1997.
- Barker, David K. *Designs of Bhutan*. Bangkok: White Lotus, 1985.
- Bartholomew, Mark. *Thunder Dragon Textiles from Bhutan*. Kyoto: Shikosha, 1985.
- Bhushan, Jamila Brij. *The Costumes and Textiles of India*. Bombay: Taraporevala, 1958.
- Dar, S. N. *Costumes of India and Pakistan*. Bombay: Taraporevala, 1969.
- Dhamija, Jasleen, and Jyotindra Jain. *Handwoven Fabrics of India*. Ahmedabad, India: Mapin, 1989.
- Dunsmore, Susi. *Nepalese Textiles*. London: British Museum Press, 1993.
- Goldstein, Melvin, and Cynthia M. Beall. *Nomads of Western Tibet*. Berkeley: University of California Press, 1990.
- Goswamy, B. N. *Indian Costumes in the Collection of the Calico Museum of Textiles*. Ahmedabad, India: The Calico Museum, 1993.
- Lynton, Linda. *The Sari*. New York: Harry N. Abrams, 1995.
- Maloney, Clarence. *People of the Maldive Islands*. Madras: Orient Longman, 1980.
- Myers, Diana K. *From the Land of the Thunder Dragon*. Salem, Mass.: Peabody Essex Museum, 1994.
- Nabholz-Kartaschoff, Marie-Louise. *Golden Sprays and Scarlet Flowers*. Kyoto: Shikosha, 1986.
- Yacopino, Feliccia. *Threadlines Pakistan*. Karachi, Pakistan: Ministry of Industries, 1977.

*Internet Resources*

- Ciolek, Dr. T. Matthew. "Tibetan Studies WWW Virtual Library." Available from <<http://www.ciolek.com/wwwvl-TibetanStudies.html>>.
- Craft Revival Trust: Indian Handicrafts, Textiles, Artisans, Craftspersons. Available from <<http://www.craftrevival.org>>.
- Fernando, Romesh. "A Time of Toplessness." Available from <<http://livingheritage.org/toplessness.htm>>.
- Hettiarachchi, Rohan. "Virtual Library of Sri Lanka." Available from <<http://www.lankalibrary.com>>.
- InfoLanka: Gateway to Sri Lanka. Available from <<http://www.infolanka.com>>.
- "Kingdom of Bhutan Country." Far Flung Places LLC and Bhutan Tourism Corporation Ltd. Available from <<http://www.kingdomofbhutan.com/kingdom.html>>.
- Maldives Culture Magazine*. Available from <<http://www.maldivesculture.com/main.html>>.
- "Tibetan Costume and Ornaments." China Tibet Information Center. Available from <<http://www.tibet.cn/tibetzn-en/tcao/3robes/3jianjie.htm>>.
- Tibet Online. Available from <<http://www.Tibet.org>>.

"Nepal Information: People and Culture." Travel Information Network. Available from <[http://www.visitnepal.com/Nepal\\_information/people.htm](http://www.visitnepal.com/Nepal_information/people.htm)>.

Victoria Z. Rivers

**TEXTILES, SOUTHEAST ASIAN ISLANDS**

The textile traditions of insular Southeast Asia, an area from Sumatra, the westernmost island of Indonesia, to the northernmost region of Luzon in the Philippine Islands, covers an equally wide variety of types, styles, and traditions. These insular people are related by language and customs from former waves of migrations and by methods of textile manufacture as well as design elements and patterns. Trade through the region influenced styles with those in direct contact adapting new techniques of weaving while peoples farthest from these influences retained older traditions the longest. The following essay examines textiles in insular Southeast Asia from the broad perspective, seeking commonalities that link groups and regions together.

**Reception of New Forms**

Very early on plant products (bark, leaves, and vines) were processed to use as coverings for parts of the body. In the warm tropics minimal covering was necessary; what was worn was mainly to protect certain parts of the body, the genitals and the head. Other pieces of clothing made of plant products were more decorative than functional (capas, caps, shawls, or shoulder cloths) or fabrics are made as furniture (floor mats, wall dividers, hangings, coverings) for ceremonies and festivals. The end use and function dictated the size and shape of the pieces as well as the materials employed. Thus, large woven mats were used as coverings for the ground, as wall partitions, as sleeping surfaces, or to wrap the bodies of the deceased; bark cloth, a more pliable material, served as skirts, breast coverings, headcloths, loincloths, capas, and caps or hoods.

Woven materials existed long before the adoption of loom weaving in the area. An examination of the variety of twining and net making from neighboring peoples in New Guinea reveals older customs that may have existed prior to the adoption of weaving in Southeast Asia. Mats and baskets woven of reeds, vines, and grasses are an ancient craft form in insular Southeast Asia. Functional pieces such as containers and mats were quite light, which made them easily transported. Designs were easily woven into basketry. Complex patterns from mats and baskets of some tribal groups (Iban of Borneo and Kalimantan) were readily transferred to cloth weaving. The technology employed in weaving fine mats from fibers as thin as thread was in use in the Philippines. Such plaiting can withstand folding without breaking the fibers, unlike coarser materials used in mat weaving. Twining using bast fibers may have been an intermediary step between loom weaving and basketry. Here the process of spinning

strands to produce a continuous thread was known, but the loom frame necessary for maintaining tension on the threads to produce a tight weave was yet to be discovered or adopted.

### Origins: First Cloth

Cloth from the bark of trees was used to make practical items of clothing such as loincloths or G-strings for men and narrow hip wraps for women. Scarves would have protected the head from sun or rain. To produce bark cloth, the inner layer of certain kinds of trees was removed, then beaten to produce a soft, flexible material that could be worn next to the skin without chafing it. Clothing that was cut and sewn together and pieces that were elaborately decorated were probably reserved for individuals of high status and wealth or for communal ceremonies. Old photographs and early museum pieces stand as records of early examples of bark cloth from Southeast Asian peoples.

In Indonesia some of the finest examples of bark cloth clothing are found among the Toraja (from the highlands of central Sulawesi), where women's blouselike tops with sleeves were decorated with painted designs. The Kayan people of Borneo created vestlike jackets with painted motifs. Rectangular cloths in Bali were painted with stories or calendars of the Balinese year. Decorative bark cloth was used to cover the deceased; square cloths to cover the head. In Palu, North Sulawesi women wore full-tiered skirts. Toraja women wore dark-colored cowl-like hoods to signify widowhood. The T'boli of the Southern Philippines cut and sewed shirts and trousers of bark cloth, shapes that were repeated later on in woven fabric. Examples of bark cloth are preserved in some cultures because they are still a part of certain sacred ceremonies (Bali calendars). However, in most areas bark cloth has been replaced by woven cloth; skills necessary for production have been lost, and this type of fabric has become extinct.

### Loom Weaving

While the origin of loom weaving is unknown, it is assumed to have been introduced in ancient times. Its antiquity can be inferred by the fact that some cultures possess legends about weaving. The Bagobo, Mandaya, and Bilaan have origin myths that mention the weaving and dyeing of bast fibers. (In many of these cultures, spirits are invoked to ensure skill and accuracy during the weaving process. Certain weaving implements are considered sacred.) For the Sundanese, in West Java, the introduction of weaving is attributed to the rice goddess, Sang Hyang Dewi Sri. There are Javanese stories of types of *lurik* (a plain-weave cloth) that enable a goddess to fly. Among the Batak, a distinctive cloth used in rituals, the *ulos*, was said to have been the first weaving given to humankind. Possibly early woven pieces were the reserve of the wealthy and worn only for ceremonial purposes or used in rituals. As looms and the technique of weaving

became common, cloth quickly became the fiber of choice as a covering for the body and for use in rituals.

### Wearing of Cloth

A common theme about cloth that links insular Southeast Asian cultures (as well as mainland Southeast Asia) is that woven cloth is rarely cut to the shape of the body but rather draped or folded. In the warm, humid climate draping allowed air to circulate around the body. More importantly, the respect for the design on the cloth may have led to this preferred method of dress. A typical rectangular piece about two and a half meters in length with open ends (*kain*) is wrapped around the waist and tucked in or cinched by a belt. Two identical pieces sewn in the middle allow the wearer to start the cloth above the breasts with enough width to cover the ankles (most Indonesian cultures). Among the mountain tribes of Luzon, the width covered the female body from the waist to the knees. The result of this draped fabric was that the intricate designs woven into the cloth were not compromised and were visible over the entire front of the body.

Another style for the lower half of the body is a rectangle sewn at the ends to form a tube (*sarong*), which becomes a skirt, worn by a man or a woman. Other uses for various sizes of cloth are as follows: a long, narrow strip of cloth serving as a loincloth with end flaps in front and back; a breast covering (Bali, Java royalty, Eastern Indonesia); and a decorative sash worn over the shoulders by a man or a woman (Eastern Indonesia, Sumatra, northern Philippines cultures, for example). A rectangle tied at the shoulders serves as a baby carrier or sling to carry goods. A square folded in many different ways becomes a hat or head scarf (for example, the Batak fashioned a two-pronged head covering that imitates the horns of the water buffalo). A plain two-meter length serves as a sheet or covering for the shoulders when it is cool. Clothing had no pockets, so woven knapsacks or bags served as containers. In some cultures, layers of cloth draped on the body, one on top of the other, symbolized wealth and position (Central Javanese royalty, Timor cultures). On the practical side, uncut cloth lengths were more easily folded for storage.

Cloth that was cut generally was not woven with the elaborate designs that uncut cloth possessed. This cloth followed the shape of the weave; thus, a sleeveless shirt was made by cutting an opening in the middle of the cloth for the head; the selvages were sewn together leaving only holes for the arms (Gayo of Sumatra, Toraja of Sulawesi, Bagobo, Bilaan and Mandaya of Mindanao). Jackets with sleeves also followed the form of the weave with the sleeves (end pieces of the fabric cut and sewn onto the selvages at the ends (Kauer of Sumatra, Iban of Borneo, Bagobo, Mandaya and Bilaan of Mindanao, and peoples of Northern Luzon). These were usually richly decorated with anthropomorphic or zoomorphic forms and geometric designs. Patterns were created in embroidery, and



with beads, seeds, or shells at the neck and front slit and along the edges of the sleeve; more often the entire front and back was richly embroidered.

### Division of Labor

Women were the weavers for home use and in the small cottage industry. Girls from an early age participated in steps of the process, starting with processing the fiber and spinning. Young girls first learned basic weaves; in their late teens they were taught the complex process of weaving patterns using supplementary weft or warp threads and working with fine fibers such as silk. Dyeing was generally a task left for the older women. Some women, usually an older woman, were specialists in certain types of dyes, such as indigo; these women were considered to have special powers over these dyes. In their late teens young women were entrusted with the treasured patterns. In some areas girls wove their own wedding cloths, some of which were given during the nuptial celebration by the bride's family to the groom's family. In Java, *lurik*, a relatively plain cloth worn by participants in ceremonies, is given by the groom's family to the bride's.

Patterns were the reserve of women of the family in some areas (Eastern Sumba), handed down from generation to generation. The patterns were preserved as examples so that each generation could copy them. If there were no more female weavers in the family, the patterns were buried with the last known weaver rather than risk having these revealed to someone outside the line of descent.

Some patterns were the preserve of descent groups, and the patterns worn by the members (women and men) identified them with a particular descent group (Savu Island people). In Rote, patterns identified a person with a particular kingdom. In some areas, such as East Sumba, bright colors and certain patterns were reserved for royalty; the commoners were relegated to one or two colors and little patterning. Generally subdued patterns or plain cloth was worn for daily use; the intricate, highly patterned, and colorful textiles were reserved for ceremonies. In Java, even in the early 2000s, *lurik* was said to ward off bad luck. Participants wore *lurik* in ceremonies after a marriage proposal, for the bathing ritual of a pregnant woman in her seventh month, and for the first haircutting of a child. The fact that this fabric has been used by people of all social classes for specific ritual is a good indicator that *lurik* was well established in ritual life of the Javanese long before batik was introduced. For status among the Javanese some batik patterns were reserved for royalty, other patterns for wedding cloth, others associated with the retainers at court, and still others used by commoners.

### Types of Looms

The back-strap loom, a conveniently portable weaving mechanism, was the earliest form of loom. To this day, some cultures in areas away from major population centers continue to produce textiles by this means. The most

ancient form of weaving involved a continuous warp with patterns created on the warp threads. Through trade new fibers (silk) and techniques were adopted. Weft patterning replaced warp patterning in coastal areas that were directly in contact with trade from India. The adoption of the frame loom in lowland areas enabled wider and longer fabrics to be woven. Complexity of pattern, however, does not go hand in hand with the larger stationary loom. The simple backstrap loom has produced some of the most complex types of weaves in Southeast Asia—for instance, supplementary weft or warp patterns and long tapestry woven fringes that are part of the men's warrior apron in East Timor.

### Types of Fibers

The leaf fibers such as *abaca* (a variety of banana plant), and ramie and hemp, bast or stem fibers, were probably used very early on in twining as well as in the first weaving. The Philippines is noted for its use of these fibers in combination with cotton or silk as warp or weft threads. *Abaca* and hemp are the main fibers for clothing of Mindanao cultural groups. A leaf fiber that developed quite late in the Philippines is *piña* or pineapple fiber. It is unusual in that it is knotted rather than twisted to make thread. Probably more widespread throughout the Philippines and Indonesia, it is now produced solely in Aklan province.

Cotton, however, is the main material used in the production of textiles throughout insular Southeast Asia. It is used in combination with leaf or bast fibers as well as with silk. Cotton plants are easily processed for home consumption, thus making this fiber the egalitarian material. Most village people can produce enough cotton to serve their own cloth-making needs. Thus, the skill in weaving technique rather than the high cost of the materials determines the status of the weaver and wearer. Most mountain groups still produce most cloth from cotton, although now they generally purchase the thread rather than produce it themselves.

Silk, a late arrival, probably from China, became a popular cloth for the wealthy. The ability of silk thread to absorb dyes, producing vibrant colors, was one of its main attractions. As silk production developed in insular Southeast Asia, its use became more widespread. To cut costs and for ease in weaving, silk is mixed with cotton or other plant fibers. The Philippines in particular create a fabric, *sinamay*, that combines *piña* or a hemp warp with a silk or fine *abaca* weft for a type of men's shirt, the *barong Tagalog*.

*Piña*, like silk, is time consuming to process and was used in special garments for the wealthy. *Piña* fiber clothing imitated the Spanish-style dress. Wealthy Spanish, mestizos, and Philippine women wore blouses (*camisa*) and kerchiefs (*pañuelos*) over Spanish-style collars with long voluminous silk skirts; the men wore long-sleeved shirts over trousers. *Piña* fiber clothing and cloths were

heavily embroidered with patterns borrowed from Spanish motifs—flowers, vine, or religious symbols—along with some native plants. Its popularity went beyond the Philippines. Finely embroidered handkerchiefs and collars were imported to Spain and the United States in the late nineteenth century. Many fine examples of pieces of clothing exist in collections but only a few sacred cloths used as vestments or altar cloths exist.

### Production Techniques

A division can be made between those cultures that continued to produce warp-patterned weaving (a more ancient tradition) and those that switched to weft-patterned weaving. Silk is generally associated with weft-patterned weaving and is a fabric most often found in lowland cultures (Bali, Java, Sunda, Mindanao) that were associating with traders from India and China. Sumptuous supplementary weft patterns in gold thread were added to the silk cloth and were worn by high-status persons at weddings or other ritual occasions. In the Lampung area metallic thread and mirrors were embroidered on plain cottons to produce a luxurious cloth. Wealth was woven into cloth as it was received in trade. In Java and Bali gold leaf or paint was applied to plain fabric or batik designs to create a sumptuous-looking cloth, which was especially effective in a performance context. Theater was a means of attracting and ensuring the support of the masses, and the glitter of metallic threads and mirrors on cloth was a visible means of marking the status of the elite and creating a sense of pageantry for these emerging polities.

In inland cultures, which were less affected by trade, cloth was more closely linked to cohesion of the group. Designs and colors were the reserve of the high-status person in the village, but to some extent the distinctions between commoner and high status was less than it was in the large-scale societies of Java, Bali, and lowland Philippines. Status was linked to skills, such as prowess for the warrior class. Skills in head-hunting were acknowledged by special sashes, designs in weaves, or other articles of clothing worn by the successful hunter (Iban, Mindanao cultural groups, Nusatenggara region). Skull trees figure on Sumba cloths that once were associated with this practice. In Mindanao cloth that was predominantly red in color was symbolic of the success of a headhunter, and the Iban, too, used red for cloth in rituals for head-hunting.

### Conclusion

The textile traditions of insular Southeast Asia identify a cultural group by their design, colors, and style. Their beauty has attracted much devotion of research at a time when their function in these cultures is waning. Change is not uniform. Some cultures quickly adopt change (the Achenese now wear a Persian-style tunic and favor gold couched embroidery in plant patterns or Arabic writing for their clothing and religious articles). As in the past when woven cotton cloth replaced bark cloth, so, too, new materials and styles are replacing the traditional

pieces that are so admired. Status that was marked by the use of textiles has been replaced by other objects that are highly valued—a car, a TV, radio, name-brand jeans, and so forth. Instead of a pile of textiles as a gift of exchange in marriage, a Western bed and microwave might be given. One can lament the loss of the former rich tradition of textile weaving, yet its value was woven into its role in the society. As symbols of status and wealth change, its role is reduced. However, for critical communal ceremonies, change occurs more slowly. The ritual cloths of old will emerge from storage chests to ensure that the spirits are remembered and appeased to guarantee good health, a long life, and happiness in birth or marriage, or a peaceful existence in death.

See also **Asia, Southeastern Islands and the Pacific: History of Dress.**

### BIBLIOGRAPHY

- Fraser-Lu, Sylvia. *Handwoven Textiles of South-East Asia*. Singapore: Oxford University Press, 1988.
- Gittinger, Mattiebelle. *Splendid Symbols: Textiles and Tradition in Indonesia*. Washington, D.C.: The Textile Museum, 1979.
- Haddon, A. C., and L. E. Start. *Iban or Sea Dayak Fabrics and their Patterns*. Cambridge, U.K.: Cambridge University Press, 1936.
- Hamilton, Roy W., ed. *From the Rainbow's Varied Hue: Textiles of the Southern Philippines*. Los Angeles: UCLA Fowler Museum of Cultural History, 1998.
- Maxwell, Robyn. *Textiles of Southeast Asia: Tradition, Trade, and Transformation*. Rev. Ed. Hong Kong: Periplus Editions Ltd., 2003.
- Roces, Marian Pastor. *Sinaunang Habi: Philippine Ancestral Weave*. Manila, the Philippines: The Nikki Coseteng Filipiniana Series, 1991.

*Ann Wright-Parsons*

### TEXTILES, SOUTHEAST ASIAN MAINLAND

The textiles of mainland Southeast Asia share much of their production technology, design repertoires, and consumption patterns with other regions of Asia to the north (China) and west (South Asia, India), as well as insular Southeast Asia. The student of mainland Southeast Asian textiles must be as concerned with Indian, Bhutanese, and Northeast Indian textiles, and those of Southwestern and southern China, including Hainan Island and aboriginal Taiwan, as with the more traditional areas of the mainland, included in the current political entities of Vietnam, Laos, Cambodia, Thailand, Burma (Myanmar), and peninsular Malaysia. Exploration of continuities and discontinuities between “traditional” Southeast Asia and the peoples, cultures, and textiles of these “peripheral” regions pays great dividends. The migrations of many Southeast Asian cultures began in southern China, and mainland Southeast Asia’s major religion, Theravada Buddhism, and its textiles came from

South Asia; also, South Asia and China provided royal textiles which became models emulated even in rural Southeast Asia.

The region's "traditional" textiles include tube skirts, shawls, blankets, and other items that have as their probable model weaving on back-tensioned looms with circular warps. These can be elaborated in a variety of ways, using resist tie-dyed warp or weft elements, intricate supplementary weft or warp floats, tapestry weaves, appliqués, embroideries, and other methods. Additionally, Southeast Asian textiles include Buddhist monk's robes, developed by the Buddha to contrast with the uncut textile tradition of South Asia, as well as tailored coats, pants, and robes derived from Chinese forms.

### Early Southeast Asian Textiles

While it is often asserted that the preservation and recovery of Southeast Asian textiles is hindered by the region's tropical and semi-tropical climate, recent creative archaeological research has filled in some gaps. Fragments of textiles adhering to bone caused by bronze deposition have been discovered in Ban Chiang (Northeast Thai) sites. Innovative archaeological recovery techniques from burials have shown that asbestos was used to make cloth. Finally, Green's (2000) work on Khmer bas-reliefs used to decorate Angkorean temples shows that these consisted of designs found on Indian block-printed and ikat-motifed cloth also found in Fustat, Egypt. This innovative work shows that earlier eras of textile production and consumption may not be lost.

### Historical Southeast Asian Textiles

With European contact one begins to gain a more holistic sense of the complex world of mainland Southeast Asian textiles. Unfortunately, most early information is concerned with textile display and consumption within the worlds of Southeast Asian monarchies. Louis XIV's French ambassadors' discussions of their 1685 reception at Ayutthaya (then capital of Siam) show that the extensive use of textiles reflected their reception's significance, as well as designated the ranks of the various people involved in these ceremonies. Many of the textiles sent in return by King Narai were noted as coming from Persia, Hindustan, Japan, and China. This evidenced the cosmopolitan connections of Southeast Asian kingship. Non-Southeast Asian pieces using block-prints and metallic interweave, quite beautiful and sumptuous, served as markers of god-king status and as gifts to subjects to secure their status, roles, and allegiances to the monarchy. The goal of European adventurers and trading companies was to imitate and insert themselves into this lucrative, royally controlled South Asian trade as part of their monopolistic takeover of world trading patterns.

However, because of the rigors of Southeast Asian environments, cloth's intensive uses, and the difficulties of production before industrial manufacture, little is known of nonelite textiles prior to the mid-1800s. It is

assumed that local production of silk and cotton yarn and trade in this yarn and textiles was a part of local life. Early European explorers venturing into mainland, especially upland, northern Southeast Asia were impressed with the amount of trade with southwestern China in cotton and silk yarn: cotton was traded north, silk came south. Additionally, explorers visiting the royal families of the northern principalities were impressed by the use of Chinese textiles in the repertory, partially to replace textiles traded or granted by kings to the south.

Members of the Mekong expedition of 1866–1868 were awed by the willingness of local women to trade homemade textiles for European goods. Finally, in addition to having use as clothing, textiles acted as currency. Careful studies of tax receipts flowing into Bangkok from upcountry dependencies during the early reigns of the Chakri dynasty (1782–c. 1830) show that white cotton cloth was a major tribute item. In part, this cloth was requisitioned for royal funerals; in many Southeast Asian cultures, white cloth is required for wrapping the deceased. For royal funerals, even more was needed to dignify the cremation bier and for participant dress (Lefferts, 1994). Some upland Lao cultures use magnificent lengths of tied-weft silk cloth to adorn coffins.

Rural production of Southeast Asian textiles takes place at the household level. It is women's work; women are responsible for growing cotton, raising mulberry trees and silkworms, controlling the production technology, weaving, and, finally, distributing the cloth. However, as the evidence of cloth for tribute indicates, this does not mean that women could engage in this production without elite interference. Bowie has documented that, under rigorous royal control, severe constraints could be placed on local production. In the late nineteenth and early twentieth centuries, it was quite common for northern Thai villagers to wear rags and patched clothing. However, in many other locations, elite control of textile production was probably less severe, laying the foundation for the florescence of wondrously woven textiles that came to light in the late twentieth century.

### Twentieth-Century Textiles

Industrially produced textiles, initially from the looms of England and France, but, later production, from pre-World War II Shanghai, South Asian, and American factories, coupled with the intrusion of European tailored clothes, wrought major changes in rural Southeast Asian textile production and urban and rural consumption.

Domestic production of white cloth declined dramatically. Rather than remaining a major consumer of a woman's production, white cloth became a residual meant for donation and personal use. In addition to funerals, a major use was in monk's robes. Cheap, factory-made white cloth, smooth (in contrast with rough home-spun and home-woven pieces), cut, sewn, and dyed the appropriate saffron color, seems to have quickly re-



placed much of the demand for white cloth produced by rural women. At the same time, white cloth tribute ceased, replaced by government levies for cash to run expanding bureaucracies. Finally, the first chemical indigo dyes produced in Euro-American factories, rapidly followed by the development of other artificial colors, replaced locally produced natural dyes. Brilliant chemical dyes proved a boon to Southeast Asian weavers and consumers who wanted sharp colors that contrasted with the dull dyes they had endured for generations.

While there is no secure data, it seems that the period leading up to and through World War II and the following one to two decades resulted in the production of an extraordinary range of indigenous village textiles of complicated designs and patterns, a creative explosion by many accomplished women. These textiles, many used but even more saved for future use, flooded the textile markets of Southeast Asia following the end of the cold war and the opening of transportation and consumption across the whole broad sweep of northern mainland Southeast Asia and southern China. It is fair to say that these textiles represented a culmination of Southeast Asian women's artistic and technological prowess. This was especially the case in the cloth women wove for their own garments, both skirts and sashes. Beautiful tie-dyed patterns dominated in some areas, while in others complicated brocades produced by a loom with a multistrand vertical pattern heddle became common. Finally, in some areas, complicated tapestry weaves and double-warp cloth with supplementary weft became standard.

Euro-American and Japanese connoisseurs became aware of Southeast Asian textiles through the dispersal of Southeast Asian refugees fleeing the American-Indochinese War. These groups included highlanders, some of whom, such as the Hmong (Miao, Meo), were relatively recent migrants into Southeast Asia from China; others, such as the Thai Dam and Thai Khaaw (Black and White Thai) and ethnic Lao of Laos, had been wet-rice cultivators resident in their areas for several generations. All were displaced by war and arrived in refugee camps and countries of final settlement with their traditions, homemade textiles, and demands to reinstitute their culture. The evolution of indigenously produced textiles into articles of consumption by neighbors becoming aware of these refugees, such as the "story quilts" of the Hmong and other changes to their design repertory, has been documented by Cohen. Other weaving traditions, such as that of Lao women in the U.S. and France, have also survived. Several mainland Southeast Asian textile producers have been awarded personal recognition, as, for instance, through the U.S. National Endowment for the Arts National Heritage Fellowship program.

#### **Mainland Southeast Asian Textiles Production**

Detailed studies of the production technologies of mainland Southeast Asian textiles are now bearing fruit. The

relation between the woman producer and her material and equipment is a more holistic one than for the typical Euro-American loom. Usually, the loom itself and much of its equipment is made by a man and gifted to the woman as a mark of respect or an inducement to undertake production, considering that textiles are one of the important ways by which a household may gain supplementary income and prestige.

Among some populations, cloth production is magically potent; men are forbidden from touching the loom. A weaver may be viewed as producing a changeable substance, resulting in something of a different quality from that with which she began. Thus, textile production may metaphorically represent a girl's maturation to womanly status, with the ability to bring new humans into the world.

In mainland as well as insular Southeast Asia, the means of textile production as well as knowledge of its technology is controlled by women. Women in many Southeast Asian cultures derive symbolic and cultural capital from their control of weaving and the disposition of production.

Women's textile production may make substantial contributions to household income. While textile production may vary through the year depending on the requirements and opportunities of other employment, textile production used to be, and, for many women remains, an important skill. At minimum, women can produce cloth for which the household would have to spend precious cash. Most weaving takes place using long warps containing several pieces to be cut off as needed. The weaver can give pieces to various individuals, keep others for future giving, or sell some or all of them as opportunities appear. The opportunity cost of time, coupled with the defrayed expenditures for purchasing textiles and the possibility of income production, thus may make a woman's weaving an essential part of household survival.

#### **Modern Southeast Asian Textiles**

The global reach of market forces into upland mainland Southeast Asia in the early 1990s resulted in the export of massive numbers of technologically important and aesthetically beautiful indigenous textiles. Most of these left the region without proper provenance or notes as to the uses to which they could be put. Moreover, this export robbed future weavers of pattern cloths of models for future designs and techniques.

However, even as commercialization and globalization have conspired to obliterate the indigenous, home-based production of mainland Southeast Asian textiles, countervailing forces have arisen to preserve and record it. Research by Western weavers and by scholars in mainland Southeast Asian textiles is relatively recent, beginning in earnest in the late 1980s. This effort has resulted in detailed studies of textile contexts, meanings, and uses. Importantly, accomplished foreign weavers have become

interested in detailed studies of the intricacies of mainland Southeast Asian production technology. Because textile production is a process, these studies must include numerous still photographs or, even better, detailed, focused video. Fortunately, this work is underway and important studies are now appearing.

Finally, efforts are underway to conserve some of these traditions. Her Majesty, Queen Sirikit of Thailand, through her royally sponsored Support Foundation (the French acronym for Foundation for the Promotion of Supplementary Occupations and Related Techniques), has, for many years, supported local craftspeople who are expert in modes of production and design. For her pioneering and continuing efforts, Queen Sirikit won an ATA (Aid to Artisans) 2004 Award for Preservation of Craft. In Laos, the Lao Women's Union and private entrepreneur Carol Cassidy are engaged in preserving and expanding the repertoire of Lao weaving and bringing it international recognition. Similarly, in the early 1990s in devastated Cambodia, UNESCO began a massive effort not only to reestablish textile production, but also to reinstitute the cultivation of mulberry trees and silk yarn production to support it. In the early 2000s, some of the glory of Khmer silk weaving is returning. All of these efforts depend on working with local people, usually women, who remember what they accomplished so easily many years earlier, letting them know that their knowledge is of value and encouraging them to share it with others. Most of all, these and other efforts return income to villagers who have begun to see themselves as only poor and without meaningful resources.

See also **Textiles, South Asian; Textiles, Southeast Asian Islands.**

#### BIBLIOGRAPHY

- Bowie, Katherine A. "Labor Organization and Textile Trade in Northern Thailand in the Nineteenth Century." In *Textiles in Trade, Proceedings of The Textile Society of America Biennial Symposium*. Washington, D.C., 14–16 September 1990, pp. 204–215. Analysis of royal control of pre-modern textile production.
- Cohen, Eric. *The Commercialized Crafts of Thailand: Hill Tribes and Lowland Villages, Collected Articles*. Honolulu: University of Hawaii Press, 2000. Extensive selection of articles on Hmong textile adaptations to globalization and commercialization.
- Conway, Susan. *Silken Threads and Lacquer Thrones: Lanna Court Textiles*. Bangkok: River Press, 2002. Comprehensive discussion of northern Thai royal textile traditions.
- Gittinger, Mattiebelle, and Leedom Lefferts. *Textiles and the Tai Experience in Southeast Asia*. Washington, D.C.: The Textile Museum, 1992. Gittinger's chapter 1, "An Examination of Tai Textile Forms," provides a statement concerning the evolution of many mainstream Southeast Asian textiles; her chapter 4, "Textiles in the Service of Kings," provides an excellent summary of royal relations with external textile producers. Lefferts's chapter 2, "Contexts and Meanings in Tai Textiles," focuses on the sym-

bolic significance of women's control of textile production and gifting.

- Green, Gill. "Angkor: Textiles at the Khmer Court, Origins and Innovations." *Arts of Asia* 30, no. 4 (2000): 82–92.
- Howard, Michael C., and Kim Be Howard. *Textiles of the Daic Peoples of Vietnam; Textiles of the Central Highlands of Vietnam; and Textiles of the Highland Peoples of Northern Vietnam: Mon-Khmer, Hmong-Mien, and Tibeto Burman*. Bangkok: White Lotus. Numbers 2, 3, and 4 in the series *Studies in the Material Cultures of Southeast Asia*. Comprehensive surveys of little-understood areas.
- Lefferts, Leedom. "The Ritual Importance of the Mundane: White Cloth among the Tai of Southeast Asia." *Expedition* 38, no. 1 (1996): 37–50.
- McClintock, Deborah. *The Ladies of Laos*. Greenville, Del.: Privately issued. CD-ROM; excellent investigation with slides and video of total textile production process.

*Leedom Lefferts*

## TEXTILES AND INTERNATIONAL TRADE

Wars have been fought, ships sunk, and broader trade wars initiated over trade in textiles. No other industry comes close to matching the significant role the textile sector has held in the history of trade. Inventories of early sailing ships listed textiles as a vital part of the cargo. Critical to the economic development of country after country, the textile industry has provided both products and jobs needed by humans around the world. In the early 2000s, almost every country in the world produces textile goods, resulting in highly competitive global market conditions.

### Historical Perspective

In the late 1600s, British capitalists, inspired by fine cotton fabrics from India, sought ways to produce domestic goods beyond the existing household industry. Thus, England banned Indian fabrics and developed mechanized means of weaving and spinning, launching the Industrial Revolution. Having led the way in changing how goods could be produced, the textile industry provided the groundwork for the transformation of the Western world into a true international economy.

### Developments in the United States

British authorities tried to block the development of a textile industry in the colonies by refusing to share new technology and prohibiting trade with other nations. However, soon after America achieved independence, Eli Whitney's cotton gin and Samuel Slater's inventions transformed the budding industry. In years that followed, the sector led the way in many major industrial and social developments, including the emergence of factories, mill towns, employment of women outside the home, and early industrial reform. Later, it became a leader in international trade and trade problems.

Ironically, as soon as the industry began to develop in the states, they applied restrictive measures on imports, similar to the British restrictions they despised. By the late 1700s, Congress imposed tariffs and embargoes on foreign cotton to protect American cotton production. These early barriers on textile imports were a hint of later trade policies for the sector.

### Global Textile Industry

Following industrialization of the textile sector in Europe and the United States, the industry also began to spread to Asia and other parts of the less-developed world. In country after country, the textile and apparel industries became the first sector for nations as each moved beyond an agrarian society. The nineteenth century was a period of tremendous growth for the U.S. cotton industry, emerging as the country's leading manufacturing industry prior to the Civil War. New England textile mills developed and prospered. Trade in general among nations expanded greatly, and a sense of international economic interdependence developed. Expansion in the twentieth century bridged the gaps between continents, creating the global textile and apparel markets that exist in the twenty-first century.

### The Complexities of Textile Trade

In virtually every developing nation, the textile/apparel industry has been the springboard for economic development, relying on textile and apparel exports to gain much-needed income. Consequently, intense competition grew, as most countries produced textile and apparel goods for the same markets in more affluent countries. In both the United States and Western Europe, the combined textile/apparel/fiber industries were the top manufacturing employers and vital contributors to the economy in every case. Worried about loss of home markets to imports, domestic producers pressured their governments to enact measures to restrict textile and apparel imports. Political leaders could hardly afford to ignore this pressure because these large industries represented large, powerful voting blocs. As a result, complex trade policies emerged at both the international and national levels to manage textile trade.

**A trade-policy dilemma.** Applying restrictions on textile imports from other countries was a sensitive matter for the U.S. government, because this country had been one of the leaders in bringing countries together in 1947 to form the General Agreement on Tariffs and Trade (GATT). Of significance, the purpose of GATT was *to reduce and eliminate* restrictive barriers on trade from other countries. Restrictions on textile imports would seriously violate this principle.

With pressure from the United States and Europe, a multilateral system emerged that provided the protection the industry sought. Trade policies for textiles and apparel from the early 1960s on were no longer subject



**Chinese worker operating a rotor spinning machine.** The textile sector in Asia began to develop shortly after textile industrialization in Europe and the United States. © CLARO CORTES IV/REUTERS/CORBIS. REPRODUCED BY PERMISSION.

to the general rules of GATT that governed trade for all other sectors. Instead, the textile/apparel trade had its own set of rules that violated many of the basic aims of GATT by allowing restrictions on textile and apparel imports and by permitting discrimination among trading partners.

In the 1960s, policies limited cotton imports. As manufactured fibers emerged, new rules were needed to cover those. Under the resulting 1974 Multifiber Arrangement (MFA), trading partners negotiated agreements that set quota limits on the volume of textile and apparel products allowed into the more-developed countries. Always a controversial measure, less-developed nations felt the MFA quota system stifled exports in one of their leading sectors. In contrast, domestic producers in more-developed countries considered the MFA inadequate in stemming the tide of imports, while retailers and importers in those nations felt it limited their global buying. Additionally, scholars and economists considered the MFA an outrageous violation of GATT principles.



### A New Era

Developing nations had long protested the barriers on their textile and apparel goods and succeeded in bringing an end to the quota system. As part of the GATT-sponsored Uruguay Round of trade talks, GATT became the World Trade Organization (WTO), and the MFA was replaced by the Agreement on Textiles and Clothing (ATC). The ATC was basically a ten-year phase-out plan that eliminated the quota system in three stages. At the end of the ten years, quotas were removed on textile and apparel products, and tariffs were reduced. On 1 January 2005, all products in this sector came under the general WTO rules for all trade and no longer received the special protection in place for forty years.

A new global trade era emerged for the sector, and major shifts in production sites are expected to occur. Developing countries, whose economic future is tied to this sector, will undoubtedly expand exports; however, some will suffer from competition from major players such as China—no longer having the guaranteed market access that quotas provided. More developed countries are likely to see a continuing shift of textile and apparel production going to low-wage countries. Retailers have free rein to shop global markets. And, finally, consumers reap benefits from the intense global competition that provides variety and competitive prices for textile and apparel goods.

See also **Garments, International Trade in.**

### BIBLIOGRAPHY

- Aggarwal, Vinod. *Liberal Protectionism: The International Politics of Organized Textile Trade*. Berkeley: University of California Press, 1985.
- Cline, William. *The Future of World Trade in Textiles and Apparel*. Washington: Institute for International Economics, 1987.
- Dickerson, Kitty. *Textiles and Apparel in the Global Economy*, 3rd ed. Upper Saddle River, N.J.: Prentice Hall, 1999.
- Ellsworth, P. T., and J. Clark Leith. *The International Economy*, 6th ed. New York: Macmillan, 1984.

Kitty G. Dickerson

**TEXTILE WORKERS** Prior to the mid-eighteenth century, textile products were a main household manufacture, both for domestic use and on a commercial basis. Spun yarn, woven cloth, knitted stockings, and lace were the main products (Abbott 1910). Cotton, wool, flax, and hemp were the raw materials used by the women and girls in the household to make products to meet family needs; commercial weaving was often done at home by men.

Transition from the household to the shop system was slow, occurring at different times in different countries and regions. Tryon (1917) describes an “itinerant-supplementary stage” that preceded the shop system. During this stage, an itinerant worker (for example, a

weaver), could be hired to help complete the weaving process in the home. Supplementary businesses provided operations that were too difficult to do in the home. These included operations executed on the raw materials or semifinished products of the household, such as fulling, carding, dyeing, and bleaching.

During the latter part of the eighteenth century, spinning and weaving began to be mechanized, beginning in England, and “manufactories” began to take the place of household production. Mechanical spinning was much more efficient than spinning with a spinning wheel, and so factory production quickly predominated. Weaving still was often done at home, with materials being furnished by a factor or agent and the finished products returned to the manufactory. Workers were paid for each piece they had completed.

### Employment and Wage Work

In the United States, mechanized spinning quickly caught on in New England, which had excellent sources of waterpower for the purpose. Power looms for weaving were introduced in 1814 in Waltham, Massachusetts. This was the first factory in America to integrate spinning and weaving under one roof. The displacement of household manufacture brought women and children into the factory to execute tasks they had always done at home, but with different equipment and on a much larger scale.

By 1850, there were 59,136 female “hands” employed in cotton manufactures and 33,150 males throughout the country, with the largest number of females employed in Massachusetts (19,437). Employment in woolen manufacturing was dominated by male “hands,” with 22,678 men to 16,574 females. Average wages in both sectors were higher for men than for women in all states reporting (DeBow, 1854). According to Hooks, “by 1870, 104,080 women textile operatives and laborers were recorded in the census” (p. 103). During the 1900 census year, there were 298,867 men and 292,286 women, 16 years and over, employed in the different textile industries and more than 70,000 children under 16 years, with the largest number in cotton and silk manufactures (Twelfth Census, p. 12).

### Effect of Relocation on Workers

The textile industry began relocation from the North to the South after the Civil War. The move was to take advantage of a large pool of low-cost and unorganized labor. The ethnic composition of the labor force in the North was primarily native- or foreign-born whites, unskilled and recruited from the farm population. In the South, operatives were recruited mainly from among native-born whites (Bureau of the Census, 1907). In both the North and the South, the employment of blacks in the textile industry was negligible until the 1960s and the passage of the Civil Rights Act of 1964 (Minchin, 1999; Rowan, 1970).

By 1950, the total number of males employed in the textile industry (708,000) outnumbered the females (523,000). Data for 1983 shows that 49.3 percent of 742,000 workers were women, 21.3 percent were black, and 4.4 percent of Hispanic origin. By 1987, 48.1 percent of 713,000 workers were female, with 24.8 percent black and 6.6 percent of Hispanic origin (United States Department of Labor, 1988). By 2002, of the 429,000 textile workers, there were 326,000 males (76%), 88,000 blacks (20.5%), and 62,000 Hispanics (14%).

### Globalization and Free Trade Practices

While the number of textile employees declined between 1950 and 2002, the percentage of women and blacks also declined, while the percentage of Hispanics increased. The overall decrease in the number of workers has been accompanied by a decline in the American production of textiles in the post-World War II period, due to foreign competition and an influx of imports, particularly from Asian countries. Textile production and employment in the countries of Western Europe has seen similar declines.

Textile production and distribution is no longer a process of a single nation, but of a world economy. Increased foreign competition and trade exist among many textile-producing nations. To increase production and to remain competitive, textile manufacturers have invested in new machinery and techniques of production that increase the productivity of labor. This means that fewer workers are needed to “tend” to a larger number of machines. Corporations have merged, joint ventures with foreign companies have occurred, new plants have been constructed in foreign countries, and American-owned companies have increasingly shifted operations to offshore manufacturing. All of this means fewer jobs domestically, but increased employment abroad. This process is a continuation of the shift of textile jobs from high-wage to low-wage environments that was seen already in the movement of textile production from New England to the American South in the middle decades of the twentieth century.

Textile production has shifted to a number of developing countries, including China, India, Pakistan, Bulgaria, and Turkey. Because women are lower cost employees worldwide than men, textile manufacturers in these countries typically employ more than 50 percent females in textile production. Some Asian countries, including Japan and Korea, that once offered low-wage employment in the textile industry, have also seen a flight of textile production to countries with even lower wages overseas. In 2004 leading low-wage countries include Sri Lanka, Indonesia, and Bangladesh (Industrial United Nations Development Organization, 2003).

Although textile manufacturers argue that free-trade practices (such as the abandonment of trade quotas to restrain imports into the United States from China and the North American Free Trade Agreement) have been the cause of mill bankruptcies and closings and job losses in

the United States (Nesbitt, 2003), many economists point out that tariffs, quotas, and other protectionist measures are generally ineffective in maintaining employment in declining industries, and result in higher prices for consumers. Only factories offering some specific comparative advantage (for example, techno-textile production, on-demand specialty textile production, extremely high labor productivity) are likely to survive in high-wage environments in the era of globalization. The portability of the textile industry (whole factories can be dismantled in one country and reassembled in another, lower-wage one) and the relatively unskilled nature of textile work means that production of basic textiles will continue to flow to low-wage environments. An important contemporary challenge is to protect textile workers (largely female, poor, young, and vulnerable) from exploitation, industrial hazards, and other negative effects of employment in an industry that has seldom seen worker protection as a high priority.

See also **Cotton; Dyeing; Fulling; Hemp; Lace; Wool; Yarns.**

### BIBLIOGRAPHY

- Abbott, Edith. *Women in Industry: A Study in American Economic History*. New York and London: D. Appleton, 1910. Reprint, New York: Arno, 1967.
- Bureau of the Census, Department of Commerce and Labor. *Statistics of Women at Work*. Washington, D.C.: Government Printing Office, 1907.
- DeBow, J. D. B. *Statistical View of the United States: A Compendium of the Seventh Census*, Volume 15: 1854. Reprint. New York: Norman Ross, 1970.
- Dickerson, Kitty G. *Textiles and Apparel in the Global Economy*, 3rd ed. Upper Saddle River, N.J.: Prentice-Hall, 1999.
- Dublin, Thomas. *Women at Work: The Transformation of Work and Community in Lowell, Massachusetts, 1826–1860*. New York: Columbia University Press.
- Hooks, Janet M. *Women's Occupations through Seven Decades*. United States Department of Labor, Women's Bureau Bulletin no. 218. Washington, D.C.: Government Printing Office, 1947.
- Janofsky, Michael. “In South Carolina, Job Losses May Erode Support for Bush.” *New York Times*, 18 August 2003: A1, A12.
- Minchin, Timothy J. “Federal Policy and the Racial Integration of Southern Industry, 1961–1980.” *Journal of Policy History* 11, no. 2 (1999).
- Nesbitt, Jim. “Trade Policy Blamed for Textile Fall.” *Augusta Chronicle* (7 August 2003): B2.
- Rowan, Richard L. *The Negro in the Textile Industry*. Wharton School of Finance and Commerce, Report No. 20. Philadelphia: University of Pennsylvania Press, 1970.
- Sumner, Helen. *History of Women in Industry in the United States*. Report on Condition of Women and Child Wage-Earners in the United States, Volume 9. Washington, D.C.: Government Printing Office, 1910. Reprint, New York: Arno Press, 1974.
- Truchil, Barry E. *Capital-Labor Relations in the United States Textile Industry*. New York: Praeger, 1988.

## THEATRICAL COSTUME

Tryon, Rolla. *Household Manufactures in the United States, 1640–1860: A Study in Industrial History*. Chicago: University of Chicago Press, 1917.

Twelfth Census of the United States. *1900 Manufactures, Part III, Selected Reports on Selected Industries*. Washington, D.C.: United States Census Office, 1902.

Uchitelle, Louis. "Blacks Lose Jobs Faster as Middle-Class Work Drops." *New York Times* (12 July 2003): B1, B4.

United Nations Industrial Development Organization. *International Yearbook of Industrial Statistics, 2003*. Vienna: UNIDO, 2003.

### *Internet Resource*

Bureau of Labor Statistics, Current Population Survey. 2003. Unpublished detailed occupation and industry tables. Available from <<http://www.dol.gov>>.

*Gloria M. Williams*

**THEATRICAL COSTUME** Western theater tradition has its foundations in the Greek celebrations performed in the sixth century B.C.E., honoring Dionysus, the god of wine and revelry. The revels (dances, songs, and choral responses) evolved into spoken drama in 535 B.C.E., when the playwright Thespis introduced an actor to respond to the chorus leader. The result was dialogue.

Another playwright, Aeschylus (525–456 B.C.E.), is credited with establishing what became the traditional costume for Greek tragedy. It consisted of a long, sleeved, patterned tunic, a stylized mask for instant character recognition, and a pair of high-soled shoes called *corthu-nae*. All of these garments were exclusively for theatrical use. One cannot act the hero in everyday wear.

Actors in Greek comedies also wore masks to indicate which characters they portrayed. Additionally, they would often add exaggerated body parts, padded bottoms or stomachs, and oversize phalluses to heighten the comic effect. Short tunics, much like those worn by ordinary citizens, were thought appropriate to comedy.

Although the Romans added their own twists, the costume conventions established by the Greeks essentially remained the same until the fall of the Roman Empire, when Western theater virtually disappeared for eight hundred years.

### **The Middle Ages and the Renaissance**

When theater re-emerged, it did so, ironically, in the context of the church. The Christian church was the sworn enemy of the drama (perceiving it to be both immodest and akin to devil-worshipping). But, since services were performed in Latin, which fewer and fewer parishioners could understand, priests had to devise a way to dramatize the liturgy.

From the fifth century C.E. forward, mystery plays, dramatizing events in the scriptures, and miracle plays,

which depicted the lives of the saints, were increasingly performed both inside the church and on church grounds. As they became more elaborate, they moved into the market square.

Costumes worn in the early religious dramas were ecclesiastical garments. As the scripts became more secular, often involving townspeople in addition to the clergy, lay performers assumed responsibility for any costume pieces not owned by the church. Contemporary religious art provided inspiration for such characters as Daniel, Herod, the Virgin Mary, and assorted devils.

It was during the Renaissance that production elements, both scenery and costume, came to be even more important than the text. Throughout Europe, the nobility staged lavish court masques and pageants to entertain their guests. Costumes depicted gods, animals, and mythological creatures, as well as such emotions as hope and joy. Designers for these festivities included Leonardo da Vinci and Inigo Jones.

### **The Commedia Dell'arte**

Commedia dell'arte, a form of popular street comedy, emerged in Italy during the sixteenth century. Groups of itinerant actors presented largely improvised plays throughout Italy and Europe.

Like the Greek comedies (to which commedia is thought to be linked), commedia actors portrayed stock characters identifiable by their masks and by their traditional costumes. Pantaloon, the archetypal doddering old man, was often dressed in the wide trousers that now bear his name. The wily servant Brighella had a coat of horizontal green stripes, the forerunner of nineteenth-century British livery. Other comic characters include Arlecchino, or Harlequin, Il Dottore, a pedantic academic always dressed in black, and Il Capitano, a cowardly Spaniard. The serious characters in commedia, two pair of lovers and a servant girl, wore contemporary clothing.

The works of William Shakespeare, Jean-Baptiste Moliere, and Jean-Antoine Watteau all show evidence of the influence of this important popular art form.

### **The Sixteenth through the Eighteenth Century**

Costumes for Shakespeare's plays were a mixture of various periods that audiences accepted as the standard convention. Most parts were performed in contemporary dress either owned by the actor (all were men) or provided by the theater's patron. On occasion, a helmet or breastplate might indicate a soldier. Fairies and nymphs might wear classical draperies.

The same principle applies to costume in the seventeenth and eighteenth centuries. Most actors and especially actresses dressed as fashionably as possible. A turban indicated an Eastern character. A plumed helmet signified a soldier. Performers provided their own wardrobe with the exception of specialty items provided by the theater.



### The Nineteenth and Early Twentieth Centuries

The period between the 1770s and the 1870s saw a drive toward historical accuracy in costume design. As travel became relatively easier, reports, both written and visual, increased people's knowledge of other cultures. International exhibitions such as the Crystal Palace Exhibition in London in 1851 brought the material culture of exotic places to the public. They wanted what they saw and read about to be reflected on the stage.

In the German principality of Saxe-Meiningen, Duke George II established his own theatrical troupe called the Meiningers. The Duke used every available resource to create authentic costumes for his actors.

The Meiningers toured the continent widely, and the style of their productions greatly influenced such bastions of nineteenth century realism as the Théâtre Libre in Paris, and the Moscow Art Theater in Russia. In the United States, the productions of impresario David Belasco reflected his admiration for this new, realistic style.

An inevitable backlash followed. In Russia, to cite just one example, constructivist artists designed highly conceptual costumes whose only relationship to clothing was that they were worn by human beings.

Eventually both styles were recognized as valid, leading to the mixture of historically accurate or concept driven productions that continues in the twenty-first century.

### Current Practice

Theatrical costumes are designed to support the script. If realism or historicism is central to the text, the costumes will accurately reflect the clothing appropriate to the period or to the environment. Examples include Henrik Ibsen's *The Master Builder*, which requires clothing of the early 1890s, or David Storey's *The Changing Room*, which calls for uniforms and street wear appropriate for a group of rugby players in the North of England.

Other scripts require a more fanciful approach. Shakespeare's *The Tempest* must be set on an island, but that island can be anywhere in the world. Prospero and Miranda can inhabit any time period agreed upon by the director and the design team.

### Costume's Influence on Fashionable Dress

While film costume often influences fashionable clothing, theatrical costume almost never does. A film is seen by millions of people across the country in the first week of its release. By contrast, the average Broadway theater can accommodate only eight thousand people in the same one-week period.

Moreover, there is typically an interval of a year or more between the end of shooting and the film's release. In this interval fashion magazines and other periodicals can run spreads showcasing the costumes, creating customer demand. Historically, film studios, manufacturers, department stores, and dressmaker pattern companies en-

tered into partnerships to promote both the film and the ready-to-wear (or ready-to-sew) garments which the film inspired.

A classic example is the "Letty Lynton" dress worn by Joan Crawford in the 1932 film of the same name. More than 500,000 copies of Adrian's design were reportedly sold at every price point as soon as the film opened. In 1967, Theodora von Runkle's costumes for *Bonnie and Clyde* sparked the trend for 1930s revival styles that were so popular in the late 1960s. Ruth Morley's costumes for Diane Keaton produced *Annie Hall* look-alikes throughout the United States and Europe in the late 1970s.

Another reason why there can be little relationship between theatrical clothing and street wear is scale. A costume is designed to be seen from a distance of thirty or forty feet. Details are exaggerated to make them visible. Film, in contrast, is largely about close-ups. Movie costumes have to be "real" in a way that successful theatrical costumes cannot be.

A few exceptions exist, but they are rare. A red suit designed by Patricia Zipprodt for the 1969 Broadway production of Neil Simon's *Plaza Suite* was subsequently manufactured for Bergdorf Goodman. In 2002, Bloomingdale's introduced a collection of plus-size garments based on William Ivey Long's designs for the musical *Hairspray*.

The audience for a theatrical event is so small relative to the number of people who attend films that it makes little economic sense to use the theater as a design source. Contemporary clothing for the stage may reflect fashionable dress, but it does not influence it.

### Special Requirements

Above everything, a theatrical costume is designed for movement. Armholes are cut higher than they are in mass-produced clothing to permit the actor to raise his arms without the whole garment following. Crotches are cut higher to allow for kicks without splitting a seam.

Costumes must be constructed to be strong enough to withstand eight wearings a week for months or even years, with infrequent cleaning or laundering. If the script calls for a "quick change," meaning that the performer makes a complete change of clothing in under a minute, the costume will be constructed to facilitate the change. To change a shirt quickly, for example, the buttons are sewn on top of the buttonholes. The shirt is held closed by snaps or hook and loop tape so that it can literally be ripped off the performer.

Dancers shoes must have soles thin enough to allow the dancer to flex and point her foot. When custom-made, elk skin is the material of choice.

### Trends and Developments

Theatrical costumes rely heavily on natural fibers (cotton, linen, silk, and wool). Synthetics do not handle or

drape like natural fibers. That said, however, the development of new materials has had a tremendous effect on the industry.

Before the late 1950s, for example, dancer's tights were made from elasticized cotton, given to sags and bags, or they were knitted and prone to runs. The invention of Lycra, spandex, and other two-way stretch fabrics eliminated such problems. Braided nylon horsehair can be used to make ruffs that simulate the starched linen originals but which hold their shape when laundered.

No firm manufactures textiles exclusively for use in costumes. The market is far too small. Costumers, however, are extremely creative in discovering theatrical uses for products designed for other purposes. Veri-form, a brand name for a type of thermoplastic sheeting, for example, is an open weave, plastic mesh fabric used by orthopedic surgeons for lightweight casts. It makes excellent armor and masks, is nontoxic and easy to work with.

The plastic netting used to ventilate baseball caps makes indestructible and inexpensive crinolines. Air conditioning and other types of foam can be cut and sculpted to form the understructure of lightweight mascot or other costumes that are taller and broader than the actor inside them. Birdseed, encased in a body suit, is excellent to simulate the movement of sagging breasts.

The most significant development in the field in the last twenty years has undoubtedly been a heightened awareness of health and safety issues. As late as the 1970s both designers and costume makers routinely treated fabrics with highly toxic paints, solvents, and glues with no understanding of the risks involved. In the twenty-first century, not only are less toxic products available, but material safety data sheets, respirators, spray booths, and other protective devices are the norm.

While materials continue to evolve, and styles of costume design go in and out of fashion, the principle remains constant. As Robert Edmond Jones wrote in 1941, "A stage costume is a creation of the theater. Its quality is purely theatrical and taken outside the theater it loses its magic at once. It dies as a plant dies when uprooted" (p. 91).

See also **Actors and Actresses, Impact on Fashion; Art and Fashion; Ballet Costume; Theatrical Makeup.**

#### BIBLIOGRAPHY

- Bieber, Margaret. *The History of the Greek and Roman Theater*. Princeton, N.J.: Princeton University Press, 1961.
- Cheney, Sheldon. *The Theatre: Three Thousand Years of Drama, Acting and Stagecraft*. New York, London, and Toronto: Longmans, Green and Co., 1952.
- Gascoine, Bamber. *World Theater: An Illustrated History*. Boston and Toronto: Little, Brown and Co., 1968.
- Jones, Robert Edmond. *The Dramatic Imagination*. New York: Theatre Arts, 1941.
- Laver, James. *Costume in the Theatre*. New York: Hill and Wang, 1965.

Molinari, Cesare. *Theater through the Ages*. New York: McGraw Hill Book Company, 1975.

Whitney Blausen

**THEATRICAL MAKEUP** Thousands of years ago, people in many parts of the world discovered that powdered pigments mixed into a base of wax or grease could be used to create striking effects of personal adornment and transformation. The survival of that practice is reflected in a common term for theatrical makeup, "grease-paint." Select types or styles of makeup were often used for special occasions, which could include going to war, celebrating stages of life, and religious festivals. The latter often included performative aspects, such as dance and re-enactments of mythical events. Modern theatrical makeup therefore is heir to a very ancient performance tradition.

Some ancient theatrical traditions have relied on masks for the creation of visual characters; others have relied on makeup for the same purpose. In Asia, for example, one can point to the masked theater of Java and the elaborately made-up Kathakali dance theater of southwestern India, or the masked religious dances of Tibet and the strikingly masklike makeup of the Peking Opera and related theatrical forms in China. In Japan, the Noh drama is masked, while Kabuki drama employs extravagant makeup.

Ancient Greek theater was masked, but later European theater usually used stage makeup to create characters, heighten facial features, and compensate for the effects of stage lighting. (The Italian Commedia del'Arte, which continued to employ masks, was an important exception.) Until well into the twentieth century, performers were expected to do their own makeup, as they were expected to supply their own stage costumes. The professional theatrical makeup artist is a modern phenomenon, as is the theatrical costume designer.

Theatrical makeup is inseparable from the act of performance itself. The aim of theatrical makeup is to delineate and enhance the role of a character and to give performers an additional tool for conveying the characters being performed. Stage makeup is often used to create visual stereotypes or clichés that will be readily understood by the audience. Stage makeup is usually much more colorful and graphic than ordinary cosmetic makeup. When viewed closely, it can seem excessive and exaggerated, but it works when the performer is on stage being seen at a distance by the audience. Theatrical makeup itself is also heavier, more dense, and more strongly colored than ordinary cosmetics, and it is often produced in the form of lipstick-like waxy crayons or pencils. For many performers, the act of putting on makeup is an important part of the ritual of preparing for a performance; it allows the performer to move psychologically into the role of the character as the makeup is being applied.



**Kabuki actor paints on theatrical makeup.** Many ancient forms of theater, such as Kabuki, use makeup in order to enhance the characterizations of the actors. © ROYALTY-FREE/CORBIS. REPRODUCED BY PERMISSION.

Makeup artists are employed today in a variety of roles, and they often specialize in, for example, theatrical makeup, cinema makeup, fashion photography and runway makeup, or special effects. Regardless of specialty, they typically require years of training and practice to perfect their skills. Special effects makeup is particularly prominent in the world of film, but has also played an important role in the success of many popular Broadway productions, such as *Jekyll and Hyde* and *Beauty and the Beast*. In the film trilogy *The Lord of the Rings*, the prosthetic feet worn by the hobbits were made by a team of special effects makeup artists. Hundreds of pairs were made, as a new pair had to be worn daily by each actor in a hobbit role. In executing such assignments, makeup artists have to draw on skills in sculpture and other plastic arts as well as in the use of cosmetics.

Whether in the dramatic makeup of a horror film or the powerful aesthetic appeal of the unique makeup employed by the Cirque du Soleil, makeup plays an important part in establishing the characterization and impact

of a performed role. Baz Luhrmann's successful films of *Romeo and Juliet* and *Moulin Rouge*, and his stage production of *La Bohème*, owed a significant part of their theatricality and audience appeal to his production team's careful use of makeup techniques that evoked a period style. As these examples indicate, by the early twenty-first century makeup in different theatrical and fashion genres began to cross previously rigid barriers. The world of film, especially in special effects, has had a profound impact on the development of new techniques of stage makeup, and today theatrical makeup shows up regularly on fashion catwalks as well. Recent fashion shows by Dior and Givenchy, for example, have been notable for their strong sense of theater. Fashion makeup artists have begun to borrow liberally from traditional stage makeup techniques to create striking new designs that help to showcase the fashions on display. Meanwhile, theatrical makeup is enriched by new developments in film, fashion photography, and other media.

See also **Makeup Artists**.

#### BIBLIOGRAPHY

- Corson, Richard. *Fashions in Makeup: From Ancient to Modern Times*. London: Peter Owen Ltd., 1972.
- Delamar, Penny. *The Complete Make-up Artist: Working in Film, Television, and Theater*. 2nd edition. Evanston, Ill.: Northwestern University Press, 2002.
- Kehoe, Vincent. *The Technique of the Professional Make-up Artist*. New York: Focal Press, 1995.

*Elizabeth McLafferty*

**THONGS.** See **Sandals; G-string and Thong**.

**TIE-DYEING** Tie-dyeing is one of the post-weaving physical resist-dyeing techniques using binding and compression to create patterning in textiles. This basic hand process involves binding or tying a raised portion of whole cloth with thread, string, twine, raffia, rubber bands, rope, or other linear materials to "reserve" or protect areas from receiving dye penetration during a vat-immersion or dip-dye process. Although dyeing is considered a "surface" technique, through this method the dyer can create random or controlled patterning and color manipulations that are fully integrated into the fibers of the cloth. According to Jack Lenor Larsen, leading textile authority and designer, "The marriage of thirsty cloth and liquid color produces ornament not on cloth, but *in it*" (p. 9). After dyeing, when the ties or resists are removed, the resulting pattern is created from the original color of the cloth, usually some version of white or light color that was bound off, contrasted with the dyed portions. The entire process may be repeated, and layers of color from over-dyeing or selective topical





## GLOSSARY OF TECHNICAL TERMS

*Techniques Related to Tie-Dyeing*

**arashi shibori:** Japanese technique in which the cloth is compressed and tightly pleated as it is wrapped around a long pole, tied in place and dyed, giving an irregular, diagonally striped pattern to the fabric. The term *arashi* literally translated means “storm,” as the pattern simulates the linear pattern of rain (Wada, page 34).

**clamp resist or “itajime” (board-clamped dyeing):** A type of compression resist in which the cloth is folded and tightly clamped using C-clamps between a pair of two identical shapes cut from wood, plexiglas, or other dye-resistant material. The resulting reserved shape is repeated throughout the cloth based on the number of layers folded and clamped together while the surrounding area has received dye.

**dip dyeing:** Wet cloth is dipped into a series of dye baths containing increasingly darker values of the same or related color or along the edges of a folded bundle of cloth.

**fold dyeing:** The cloth is folded into small pleats so compactly that it resists the dye and is bound together with string at intervals. A variation includes twisting the folded bundle, further giving an irregular repeat design to the fabric.

**knot dyeing:** The simplest form of physical resist involves tying the rectangle of cloth on itself in knots in the corners and center before dyeing to produce bold, turbulent patterns.

**plaited or braid dyeing:** Three strips of fabric are folded lengthwise and plaited together in a threefold braid

and secured by string at the bottom before immersion in a dye bath. After dyeing they are unbraided and machine-stitched together with other braid-dyed strips side by side to form a wider cloth. The resulting pattern is an offset repeat of the exposed areas with a fringe-like edge where the ends were tied off; practiced in West Africa.

**tritik:** Javanese word for a resist-dye process in which outline patterns are stitched into a double-layered cloth using small running stitches and tightly gathered to prevent substantial penetration of dye. This creates a “mirror image,” or double rows of parallel lines of undyed dots.

*Resist Processes Related to Tie-Dyeing*

**batik:** “A resist-dye process in which the resist, usually wax, is applied to the cloth surface; when dyed, patterns are reserved in the colors of the foundation material. Sequences of waxing and dyeing result in multiple color pattern” (Gittinger, p. 240). Other resists include cassava-based paste used in Africa and rice-paste resists used in Japan.

**ikat (from Indonesia):** “[A] resist-dye process in which patterns are created in the warp or weft by tying off small bundles of yarns with a dye-resistant material prior to weaving. Resists are cut away and/or new ones added for each color. When all are removed the yarns are patterned, ready for weaving” (Gittinger, p. 240). Yarns can also be executed as a “double-ikat” in which both the warp and the weft are resist-dyed prior to weaving. The same technique is called *kasuri* in Japan; in Central America.

spot-dyeing increase the possibilities for complexity of imagery and patterning. Furthermore, the inherent crimped and puckered textures created by the compression contribute to the tactile and aesthetic appeal of the textile.

**Origins and Evolution**

The origins and evolution of traditional tie-dye methods are based upon the almost universal observation that areas of any foundation material protected from exposure to liquids, gases, heat, sun, or other substances, are left untouched in their original color or state. As a result of this protection or “resistance” to the flow of dye, the potential for controlled mark-making and patterning was discovered and subsequently explored and exploited. Typically the

most basic patterns—circles, dots, squares, and diamond shapes—are repeated in varying sizes and scale.

It is believed that tie-dyeing developed in conjunction with indigo cultivation and has been widely practiced by peoples throughout the world for centuries to decorate their clothing, including in India and Indonesia, Japan, Central Asia, West Africa, Europe, Mesoamerica, and South America, notably in pre-Columbian Peru. It was introduced to Europe in the seventeenth century by cotton calico fabrics that were usually made by resist printing. Silk-printed squares from India used as neck cloths or snuff handkerchiefs, the *bandanna*, with characteristic dot patterning, is derived from Hindu *bandhnu* (to bind or tie). This technique is also called *plangi* among Malay-Indonesian peoples and *shibori* in Japan. Most re-

cently, tie-dye was revived during the twentieth century as a major part of the 1960s “hippie” aesthetic thought to capture psychedelic phenomenon.

Specific countries and cultural areas have developed highly sophisticated and complex tie-dyeing traditions that are unique to their cultures. Historically, there is evidence of ancient Chinese silks from the ruins of As-tana (418–683), one of a number of towns along the Silk Road, the great trade route that connected East Asia with the centers of western civilization, that used tie-dye methods to create patterned textiles, as well as in ancient Persia and the Middle East. Parts of rural China continue to use tie-dye, as do areas of Japan. Similarly, India developed *plangi*, in which tiny dots of tie-dyed cloth create larger patterns and motifs as well as rich, puckered textures. Rural areas of India still embellish their saris, veils, and turbans for both daily and festive wear using tie-dye patterning.

### Japanese *Shibori*

Textile artisans, probably before recorded history in Japan, began to develop an elaborate array of highly controlled techniques for resist-dyed cloth, termed *shibori*, that was associated with particular geographical regions and became the “intellectual property” of specific villages and family groups. Most of the early patterns were based upon drawing up a portion of the cloth with the fingers and binding it around and around with thread before immersing it in the dye. The resulting patterns resemble rings, squares, or “spiderwebs,” called *kumo shibori* (Wada, p. 17). A variation of the tie-dye process, usually known to textile historians by the Indonesian (Javanese) term *tritik*, or stitch-resist, is a technique in which the outline of the design is delineated with stitches and the stitching thread is drawn up, making it possible to protect ground areas from the dye. In Japanese textiles this technique reached its perfection in the sixteenth century. Rural peoples concentrated on indigo-dyed cotton cloth used for kimonos or short jackets, called *hippari*, while silk court robes and obi sashes utilized a vast array of colorful dyes. Traditional imagery was given specific names, such as, *yanagi shibori* (willow) or *mokume shibori* (wood grain), and can be re-created with recently recorded and published methods.

### Africa

West and North Africa have specialized in indigo tie-dyed cloth, which was originally introduced through the Jewish dyers and merchants within the Muslim world. The combination of folded and bound resists with the special nature of indigo dye that requires oxidation to produce the blue color allows the textile artist to repeatedly expose the cloth very briefly to the dye bath through dipping instead of, or in addition to, immersed saturation, thereby controlling the degree and depth of penetration. In some cases seeds, pebbles, or other nonabsorbent articles are tied into the cloth to establish a uniform module for the resisted patterning. The folded or stitched areas of these

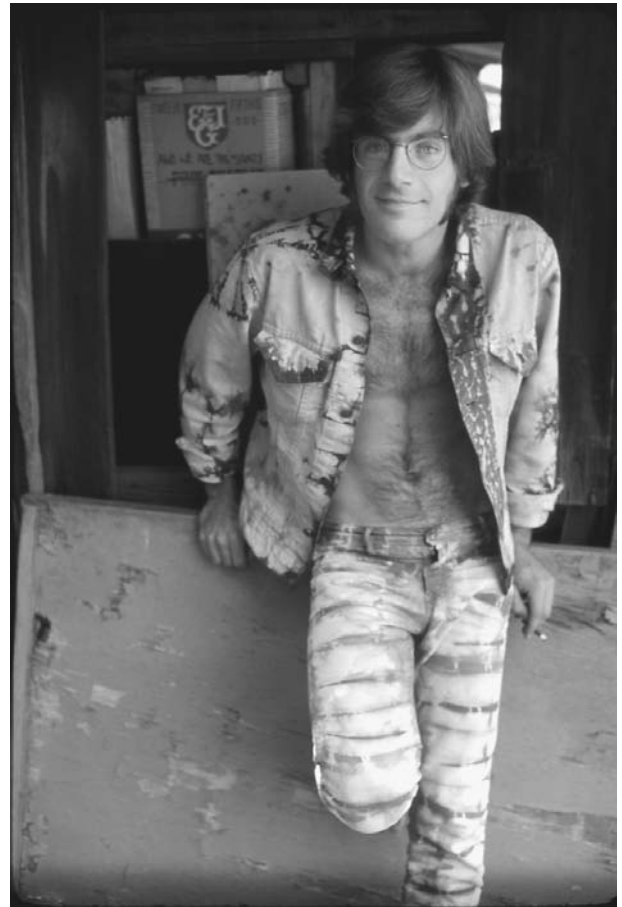

**Musician John Sebastian in a tie-dyed jacket and pants.** While the techniques of tie-dyeing date back to as early as the sixth century, tie-dyed clothing gained popularity in the 1960s with the “hippie” generation. PHOTO BY HENRY DILTZ. REPRODUCED BY PERMISSION.

primarily cotton cloths are used to create boldly striped or radiating patterns for robes, shirts, and tunics; large turbulent swirling motifs for *bou-bous* and caftans; or repeated, linear symbolic imagery for wrappers that serve as dresses and skirts. In Nigeria, the term *adire* means, quite literally, “to take, to tie and dye.” Raffia is traditionally used as the binding or stitching material in African work that also includes stitched *tritik* and embroidered resists.

Because tie-dye is based on hand-dyeing that was often practiced as a domestic household industry, the process and its resulting visual qualities fell out of fashion during the mass-industrialization of textile printing during the nineteenth and early twentieth centuries. Rather, the hard-edged block, stencil, silk-screen, and roller-based printing processes were preferred. However, with the revaluing of the individual craftsman as hands-on producer during the 1960s, the characteristically blurred visual qualities produced by dye penetrating fiber regained favor because of the visual spontaneity and rich,

uneven effects. The ubiquitous tie-dyed T-shirt became the symbol of the hippie generation. Since that revolutionary decade, many contemporary textile artist-craftsmen have explored and expanded upon a rich variety of tie-dye methods, resulting in a renaissance of these techniques during the late twentieth century. Foremost among contemporary practitioners is American Ana Lisa Hedstrom of California, whose innovative exploration of *arashi shibori* dyed-silk textiles for wearable art garments, has become trendsetting.

See also **Dyeing; Dyeing, Resist; Hippie Style; Indigo.**

#### BIBLIOGRAPHY

- Gittinger, Mattibelle, ed. *To Speak with Cloth: Studies in Indonesian Textiles*. Los Angeles: Museum of Cultural History, University of California, 1989. Excellent articles on various Indonesian textile processes in their cultural context.
- Larsen, Jack Lenor, with Alfred Buhler, Bronwen Solyom, and Garrett Solyom. *The Dyer's Art: Ikat, Batik, Plangi*. New York: Van Nostrand Reinhold, 1976. The classic authoritative source on worldwide resist-dyed textiles; superb visuals.
- Picton, John, and John Mack. *African Textiles: Looms, Weaving and Design*. London: British Museum Publications, Ltd., 1979. Thorough discussion of resist-dyed textiles; excellent photographs.
- Schoeser, Mary. *World Textiles: A Concise History*. World of Art Series. London: Thames and Hudson, Inc., 2003. Concise overview of textile processes, cultural interrelationships, and historical evolution.
- Wada, Yoshiko, Mary Kellogg Rice, and Jane Barton. *Shibori: The Inventive Art of Japanese Shaped Resist Dyeing: Tradition, Techniques, Innovation*. Tokyo: Kodansha International, 1983. Pioneer source with outstanding overview of traditional techniques with detailed diagrams and contemporary examples.

*Jo Ann C. Stabb*

**TIGHT-LACING** The term “tight-lacing” refers to the laces that tighten a corset. There is no generally accepted definition of what constitutes tight-lacing since it could be argued that any corset that is not loose is tight. Furthermore, there is no agreement as to how tightly corsets were usually laced. Some nineteenth-century writers argued that any use of the corset was dangerously unhealthy, whereas others tolerated or praised “moderate” corsetry, reserving their criticism for tight-lacing, however this might be defined. When they mentioned measurements at all, they variously defined tight-lacing as a reduction of the waist by anywhere from three to ten inches. That is, depending on the definition, a natural waist of, say, 27 inches might be reduced to a circumference of anywhere between 24 inches and 17 inches.

John Collet’s caricature *Tight Lacing, or Fashion Before Ease* (1770–1775) depicts a fashionable woman clutching a bedpost, while several people tug strenuously at her stay laces. Anyone who has seen the movie *Gone*

*with the Wind* (1939) can picture Scarlett O’Hara in a similar situation, exclaiming that if she cannot be laced down to 18 inches, she will not be able to fit into any of her dresses.

Published accounts of extreme tight-lacing in Victorian periodicals, such as *The Englishwoman’s Domestic Magazine* (EDM), describe young women reducing their waists to sixteen inches or less. For example, a letter signed Nora was published in the EDM in May 1867, claiming to have attended “a fashionable school in London” where “it was the custom for the waists of the pupils to be reduced one inch per month. When I left school . . . my waist measured only thirteen inches.” Another letter signed Walter appeared in November 1867: “I was early sent to school in Austria, where lacing is not considered ridiculous in a gentleman . . . and I objected in a thoroughly English way when the doctor’s wife required me to be laced. A sturdy *mädchen* was stoically deaf to my remonstrances, and speedily laced me up tightly . . . The daily lacing tighter and tighter produced inconvenience and absolute pain. In a few months, however, I was . . . anxious . . . to have my corsets laced as tightly as a pair of strong arms could draw them.”

Between 1867 and 1874 EDM printed dozens of letters on tight-lacing, as well as on topics such as flagellation, high heels, and spurs for lady riders. Later in the century, other periodicals, such as *The Family Doctor*, published letters and articles on tight-lacing. The notorious “corset correspondence” has been cited by some writers, such as David Kunzle, as evidence of extreme tight-lacing during the Victorian era.

However, most scholars in the early 2000s believe that these accounts represent fantasies. Indeed, by the end of the century, the tight-lacing literature becomes increasingly pornographic, as fetishist themes overlap with sadomasochistic and transvestite scenarios. Such accounts may well indicate the existence in the later nineteenth century of sexual subcultures where corset fetishists (most of whom were probably men) enacted their fantasies in settings such as specialized brothels, where they paid prostitutes to role-play as sadistic governesses. Yet this is a far cry from the use of corsets in ordinary women’s lives.

The popular belief that many Victorian women had 16-inch waists is almost certainly false. Corset advertisements in the second half of the nineteenth century usually give waist measurements of 18 to 30 inches, and larger sizes were also available. Within museum costume collections, it is rare to find a corset measuring less than 20 inches around the waist. Moreover, as the author of *The Dress Reform Problem* (1886) noted, “A distinction should be made between actual and corset measurements, because stays as ordinarily worn, do not meet at the back. Young girls, especially, derive intense satisfaction from proclaiming the diminutive size of their corset. Many purchase 18- and 19-inch stays, who must leave them open two, three, and four inches. 15, 16, and 17 inch waists are



glibly chattered about . . . [yet] we question whether it is a physical possibility for women to reduce their natural waist measure below 17 or 18 inches.”

This is not to say that women did not use corsets to reduce their waists. Writing in 1866, the English author Arnold Cooley claimed that, “The waist of healthy women . . . is found to measure 28 to 29 inches in circumference. Yet most women do not permit themselves to exceed 24 inches round the waist, whilst tens of thousands lace themselves down to 22 inches, and many deluded victims of fashion and vanity to 21 and even to 20 inches.”

The discourse on tight-lacing needs to be analyzed in ways that move beyond simple measurements. Because the practice of tight-lacing was so ill-defined and yet was perceived as being so ubiquitous in the nineteenth century, it became the focus of widespread social anxieties about women.

Tight-lacing disappeared as a social issue with the decline of the corset as a fashionable garment in the early twentieth century. However, there still existed individuals who wore tightly laced corsets. In the mid-twentieth century, Ethel Granger was listed in the *Guinness Book of World Records* for having “the world’s smallest waist,” which measured 13 inches. In the early twenty-first century, the most famous tight-lacer is probably the corsetier Mr. Pearl, who claims to have a 19-inch waist. His friend Cathie J. boasts of having reduced her waist to 15 inches.

See also **Corset; Fetish Fashion.**

#### BIBLIOGRAPHY

- Kunzle, David. *Fashion and Fetishism*. Totowa, N.J.: Rowman and Littlefield, 1982.
- Steele, Valerie. *Fetish: Fashion, Sex and Power*. New York: Oxford University Press, 1996.
- . *The Corset: A Cultural History*. New Haven and London: Yale University Press, 2001.
- Summers, Leigh. *Bound to Please*. Oxford: Berg, 2001.
- Ward, E. *The Dress Reform Problem: A Chapter for Women*. London: Hamilton, Adams, 1886.

Valerie Steele

**TOGA** The toga was a wrapped outer garment worn in ancient Rome. Its origin is probably to be found in the *tebenna*, a semicircular mantle worn by the Etruscans, a people who lived on the Italian peninsula in an area close to that occupied by the Romans. Several Roman kings were Etruscan and many elements of Etruscan culture were taken over by the Romans. The toga may have been one of these elements.

The toga was a highly symbolic garment for the Romans. It had numerous forms, but the *toga pura* or *toga virilis* was the most significant. In its earliest form the *toga pura* was a semicircle of white wool.



**Statue of Emperor Augustus in a toga.** The toga, a garment wrapped around the body and over the shoulder, was worn by all ancient Roman men, though larger and longer togas were generally reserved for Romans with status and wealth. © ARALDO DE LUCA/CORBIS. REPRODUCED BY PERMISSION.

At the time of the Roman Republic (509 B.C.E. to 27 B.C.E.) and after, only free male citizens of Rome who were at least sixteen years of age could wear this toga. It was the symbol of Roman citizenship and was required dress for official activities. Men wore togas to audiences with the Emperor and to the games played in the Roman arena.

The toga was worn outermost, over a tunic. (A tunic was a T-shaped woven garment, similar in form to a

long, modern T-shirt.) The toga wrapped around the body. The straight edge was placed at the center of the body, perpendicular to the floor. The bulk of the fabric was carried over the left shoulder, across the back and under the right arm, after which it was draped across the chest and over the left shoulder.

By the time of the Roman Empire, the earlier half-circle toga had changed its form and had an extended section added to the semicircle at the straight edge. The system of draping remained the same, however the extended section was first folded down. The overfold section fell at the front of the body and formed a pocketlike pouch, called the *simus*, into which the wearer could place objects such as a scroll of paper. As the toga became still more elaborate and larger, the *simus* eventually was too open and loose for holding things, so a knot of fabric was pulled up from underneath to form an area called the *umbo*, and this being smaller and more compact became the “pocket” area. The *umbo* may also have helped to hold the toga in place.

Individuals of some significant status wore special togas. Although both men and women had worn togas in early Roman times, by the time of the Republic only men wore togas. However, a vestige of the earlier practice remained. Sons and daughters of Roman citizens wore the *toga praetexta*, a toga with a purple border about two or three inches wide. Boys wore this toga until age fourteen to sixteen when they assumed the *toga pura*, while girls gave up the garment around the age of puberty. Certain priests and magistrates also wore the *toga praetexta*.

Political candidates wore a *toga candida* that was bleached very white. The English word “candidate” derives from the name of this garment.

A *toga picta* was purple with gold embroidery. Victorious generals and others who had been singled out for special honors were awarded the opportunity to wear this toga. A *toga pulla* appears to have been worn for mourning, and was dark or black in color. The *toga trabea* seems to have been worn by religious augurs or important officials.

The toga was an awkward garment. Roman writers speak of the difficulties in keeping the toga properly arranged. Apparently it was acceptable for men to wear longer or shorter togas. A poor man might wear a shorter toga in order to save money, while one seeking to impress others might wear an especially large and long toga. In order to keep this garment clean, it had to be washed often, which caused it to wear out frequently. Replacing a worn toga was an expense that is commented on by some Roman satirists.

By the time of the Roman Republic and after, respectable adult women did not wear togas. Prostitutes were said to wear togas, as were women who had been divorced for adultery. The connotation of a woman wearing a toga implied disapproval.

The form of the toga continued to change. It seems as if men were constantly searching for variations that made the toga easier to keep in place. In one version dating from circa 118–119 C.E. and after, the *umbo* was eliminated by wrapping the section under the right arm at a higher point and twisting that upper section to form a sort of band. This band was called a *balteus*. In the third century it was an easy step from this to “the toga with the folded bands.”

In the toga with the folded bands, the twisted *balteus* became an overfold that was folded and refolded over itself in order to form a flat, layered band of fabric that may have been fastened in place by either pinning or sewing. As the toga wrapped around the body, the bands lay flat, fitting smoothly in a diagonal band across the front of the body.

In the latter years of the Roman Empire, discipline in following prescribed forms of dress grew somewhat lax, and men preferred to wear the *pallium* instead of the toga. The *pallium* itself was an evolved form of a Greek wrapped garment, the *himation*, which draped much the same way as the toga. The *pallium* was a rectangular panel of fabric that, like the toga, ran perpendicular to the floor, around the left shoulder, under the right arm, and across the body, draping over the arm. It was a sort of skeletal form of the toga, retaining its draping but losing its semi-circular form and most of its bulk.

Although the toga in its exact Roman form has not been revived in contemporary fashion, the name “toga” is often loosely applied to fashions that feature one covered and one uncovered shoulder. Examples include the “toga dress” defined by Calasibetta (2003) as an “Asymmetric dress or at-home robe styled with one shoulder bare, the other covered” or the “toga nightgown,” which could be “styled with one shoulder.” Both were styles introduced in the 1960s (Calasibetta 2003).

See also **Ancient World: History of Dress.**

#### BIBLIOGRAPHY

- Calasibetta, C. M., and P. Tortora. *The Fairchild Dictionary of Fashion*. New York: Fairchild Publications, 2003.
- Croom, A. T. *Roman Clothing and Fashion*. Charleston, S.C.: Tempus Publishing Inc., 2000.
- Goldman, N. “Reconstructing Roman Clothing.” In *The World of Roman Costume*. Edited by J. L. Sebesta and L. Bonfante, pp. 213–237. Madison: University of Wisconsin Press, 1994.
- Houston, M. G. *Ancient Greek, Roman, and Byzantine Costume*. London: Adam and Charles Black, 1966.
- Rudd, N., trans. *The Satires of Horace and Persius*. Baltimore, Md.: Penguin Books, 1973.
- Stone, S. “The Toga: From National to Ceremonial Costume.” In *The World of Roman Costume*. Edited by J. L. Sebesta, and L. Bonfante, pp. 13–45. Madison: University of Wisconsin Press, 1994.
- Tortora, P., and K. Eubank. *Survey of Historic Costume*. New York: Fairchild Publications, 1998.

Wilson, L. M. *The Roman Toga*. Baltimore, Md.: Johns Hopkins Press, 1924.

*Phyllis Tortora*

**TOLEDO, ISABEL AND RUBEN** Ruben and Isabel Toledo are a husband-and-wife team who work closely together in several fields of fashion. She is a fashion designer known for producing clothing that combines sophisticated simplicity and meticulous craftsmanship. He is a fashion artist whose distinctive drawings have appeared in many fashion publications and whose work extends to designing mannequins and painting murals for fashionable restaurants; Isabel is his muse and almost invariably his model. He also is responsible for managing the business side of her clothing business. Theirs is a true creative partnership; it is impossible to delineate the boundaries of the contribution of each to the work of the other.

Born in Cuba in 1961, Isabel learned to sew as a child, when she was fascinated by her grandmother's sewing machine. She describes Cuban culture as one in which mastering the techniques of fine sewing was an admired accomplishment for women. When she first began designing clothes, she adopted the technique, associated with such great couturieres as Mmes. Grès and Madeleine Vionnet, of working directly with fabric by draping and cutting, designing in three dimensions. Like Claire McCardell, she works in simple materials such as denim, cotton jersey, and cotton flannel. She describes her garments as forward-looking and optimistic.

Ruben Toledo was born in Cuba in 1960; he and Isabel met in school as members of the large Cuban expatriate community of northern New Jersey. They quickly recognized one another as kindred spirits and began collaborating in art and design. They were married in 1984.

Isabel showed her first collection in 1985 and was immediately acclaimed as an important new talent on the New York fashion scene. Her clothes—architectural, slightly severe, with black or shades of gray dominating her palette—became highly prized by wearers of fashion-forward, “downtown” styles and were praised in such publications as the *Village Voice*, *Paper*, and *Visionaire*. Acquiring a cult following in New York, Paris, and Tokyo, Isabel nevertheless has had difficulties finding sufficient long-term financial backing to break out of niche markets to reach more widespread recognition.

The Toledos had a major exhibition, *Toledo/Toledo: A Marriage of Art and Fashion*, at the museum at the Fashion Institute of Technology (FIT) in 1999. Ruben's illustrations reached a wide audience in his witty book, *Style Dictionary* (1997). In one of his iconoclastic fashion illustrations, entitled “Fashion history goes on strike,” Ruben portrayed dresses from the past, from New Look to Mod, parading across the page in a militant demonstration, carrying placards reading, “Let us rest in peace! No more retro! Look forward, not backward!” Both of

the Toledos remain on the cutting edge of style, moving fashion forward.

*See also* **Art and Fashion**.

#### BIBLIOGRAPHY

- Hastreiter, Kim. “Isabel Toledo.” *Paper* (Fall 1998).  
 Mason, Christopher. “A Pair of Muses, above It All.” *New York Times* (27 February 1997).  
 Toledo, Isabel and Ruben. *Toledo/Toledo: A Marriage of Art and Fashion*. Kyoto, Japan: Korinsha Press, 1998. An exhibition catalog.  
 Toledo, Ruben. *Style Dictionary: A Visualization, Exploration, Transformation, Mutation, Documentation, Investigation, Classification, Free-association, Interpretation and Exact Quotations of Fashion Terms and a Collection of Past Works*. New York: Abbeville, 1997.

*Valerie Steele*

**TOOSH.** *See* **Cashmere and Pashmina**.

**TRADITIONAL DRESS** Traditional dress may be defined as the ensemble of garments, jewelry, and accessories rooted in the past that is worn by an identifiable group of people. Though slight changes over time in color, form, and material are acknowledged, the assemblage seems to be handed down unchanged from the past. Traditional dress or costume is a phrase used widely both by the general public and writers on dress. It conjures up images of rural people dressed in colorful, layered, exotic clothing from an idealized past in some faraway place. This notion of traditional dress has been scrutinized and found inadequate by many researchers and scholars, but its uncritical use continues into the twenty-first century. The phrase traditional dress or costume is often used interchangeably with the terms ethnic, regional, and folk dress. For a concise discussion of this terminology see Welters and for a fascinating look at how the term is used try a Web search on the words “traditional costume.”

In Webster's Third International Dictionary, tradition is defined as “an inherited or established way of thinking, feeling or doing: a cultural feature *preserved or evolved* from the past” (1993, p. 2422; italics by author). The concept of traditional dress as a static form carried over from the past is usually contrasted with the rapidly changing fashion of “the West.” Ethnographers and travelers documenting actual dress practices provided the original data for later interpretation by other researchers. Early social psychologists were primarily concerned with understanding the human element of fashion change, not with the continuity of a particular dress tradition, thus the reference to tradition or custom was usually brief. General studies of folk or traditional costume were geared toward showing the diversity and splendor of peoples of the world while more recent, specific studies tend toward more



historical and cultural analysis. Tarrant asks the pertinent questions, “What tradition?” and “How old is tradition?” (p. 153), questions that are essential for studying and analyzing the cultural and historic aspects of dress.

### Evolution and Traditional Dress

Changing customs in Navajo women’s dress shows clearly how dress traditions adapt to changing circumstances over time. Navajo myth tells of the people clothed in garments of shredded cedar bark or pounded yucca leaf. When they moved into New Mexico in the fifteenth century the Navajo wore garments of animal skin. They began to weave with wool after the Pueblo Revolt of 1680, when many Pueblo Indians, already weavers, took refuge with Navajo neighbors and taught them to weave. A dress made from two rectangular pieces of wool fabric, fastened at the shoulders, remained in use until the 1880s.

During four years (1864–1868) of confinement at Fort Sumner, the people were reduced to wearing cast-offs and garments made from flour sacks and whatever fabric they could find. With the advent of the railroad in New Mexico and the establishment of trading posts, Navajo women began to sell their wool and the blankets they made, trading for cotton cloth which they sewed into skirts and blouses. The use of a velvet blouse began in 1890, when a trader brought velvet or velveteen to a post. Only at this point did the ensemble of gathered skirt, close-fitting velvet blouse, and silver and turquoise jewelry worn in the early 2000s by elderly women and by young women on ceremonial occasions become traditional.

### Materials

Often made in the family for personal use, traditional dress uses materials commonly available where the maker lives. These materials and styles are often assumed to have evolved in response to environments—wool in cold climates, cotton in warm. But traditional dress often also incorporates imported materials obtained by trade. Exotic fabrics or notions can be incorporated into a people’s dress and become “traditional,” as Indian madras has for the Kalabari Ijo of the Niger Delta. Although no one knows where it originated, a print cloth called *ondoba*, said to have arrived with the Portuguese in the fifteenth century, “belongs” to the Nembe Ijo of the Niger Delta.

Over time, factory-made materials are commonly substituted for those once produced by hand in the home. Hand embroidery is reproduced by machine. It is also of note that men often adopt cosmopolitan styles while women, as carriers of culture, seem more inclined to retain aspects of traditional dress.

### Traditional Dress in the Early 2000s

Although immortalized in the world eye by romantic photos and tourist-oriented advertising, what is known as traditional dress is not commonly worn everyday anywhere in the world; elements of traditional styles are reg-

ularly seen. Education, access to international media, contact with outsiders, and the desire and ability to participate in global consumer culture have all contributed to changes in this form of material culture. Weddings, religious rituals, festivals, folkloric dance performances, and historical re-enactments are occasions for donning the dress of the past in parts of the world where virtually no elements of traditional dress are found in contemporary use.

In other places, traditional dress is one option in a person’s wardrobe—there are times when it is expected and necessary but other times when cosmopolitan styles are appropriate. A young woman in South India, where the sari is considered traditional, can wear a North Indian *salwar-kameez* outfit one day, jeans and T-shirt the next, an “ethnic” skirt and blouse from Rajasthan another day, but put on a sari when attending a wedding. After marriage, the same woman might wear a sari more frequently, acknowledging her change in social status as a wife and mother.

Everyone in the world follows some dress traditions in varying degree. Although Americans often don’t recognize it, there is a strong element of the past in ritual dress such as that for weddings and funerals. One would not be formally sanctioned for wearing bright colors to a funeral. However, there is a cultural tradition of black or somber dress that would be violated.

Unexamined, the phrase “traditional dress” implies a group of people living an integrated, rural life where group identity is paramount and community values are widely shared and important relative to individual expression. This romantic ideal of a meaningful community life contrasts with the perception of contemporary urban life lived in colorless anonymity. Linked with the common idea that globalized urban life is spiritually and culturally empty, this romantic ideal of traditional dress is kept alive in the minds of those who are furthest from it.

What is called traditional dress might in the early twenty-first century be more correctly called ethnic dress, donned to express diverse identities and affiliations such as cultural pride, nationalist or ethnic group politics, or to make a statement about personal, aesthetic, and cultural values.

*See also* **Ethnic Dress.**

### BIBLIOGRAPHY

- Baizerman, Suzanne, Joanne B. Eicher, and Cathleen Cerny. “Eurocentrism in the Study of Ethnic Dress.” *Dress* 20 (1993): 19–32.
- Blumer, Herbert. “Collective Behavior.” In *An Outline of the Principles of Sociology*. Edited by Robert Park. New York: Barnes and Noble, 1939.
- Boas, Franz. “The Social Organization and the Secret Societies of the Kwakiutl Indians.” Report of the U.S. National Museum for 1895. Washington, D.C.: U.S. National Museum, 1897.

- Ellwood, Charles. *An Introduction to Social Psychology*. New York: D. Appleton and Co., 1918.
- Frater, Judy. "Rabari Dress." In *Mud, Mirror, and Thread: Folk Traditions in Rural India*. Edited by Nora Fisher. Santa Fe: Museum of New Mexico Press; Ahmedabad: Mapin, 1993.
- Freeman, Richard. *Travels and Life in Ashanti and Jaman*. New York: Frederick A. Stokes Co., 1898.
- Harrold, Robert, and Phylidda Legg. *Folk Costumes of the World*. London: Cassell Academic Press, 1999.
- Hendrikson, Carol. *Weaving Identities: Construction of Dress and Self in a Highland Guatemala Town*. Austin: University of Texas, 1995.
- Kennett, Frances. *Ethnic Dress*. New York: Facts on File, 1995.
- Lentz, Carola. "Ethnic Conflict and Changing Dress Codes: A Case Study of an Indian Migrant Village in Highland Ecuador." In *Dress and Ethnicity*. Edited by Joanne B. Eicher. Oxford: Berg, 1995.
- Mera, H. P. *Navajo Women's Dresses*. General Series Bulletin No. 15. Santa Fe, N.M.: Laboratory of Anthropology, 1944.
- Sapir, Edward. "Fashion." In *Encyclopedia of the Social Sciences*. Vol. 6. New York: Macmillan, 1931.
- Sumberg, Barbara. "Dress and Ethnic Differentiation in the Niger Delta." In *Dress and Ethnicity*. Edited by Joanne Eicher. Oxford: Berg, 1995.
- Tarrant, Naomi. *The Development of Costume*. London: Routledge, 1994.
- Underhill, Ruth. *The Navajos*. Norman: University of Oklahoma, 1956.
- Weir, Shelagh. *Palestinian Costume*. Austin: University of Texas, 1989.
- Welters, Linda. "Introduction." In *Folk Dress in Europe and Anatolia*. Edited by Linda Welters. Oxford: Berg, 1999.
- Westermarck, Edward. *Marriage Ceremonies in Morocco*. London: Macmillan and Co., Ltd., 1914.
- Wilcox, R. Turner. *Folk and Festival Costume of the World*. New York: Charles Scribner's Sons, 1965.

Barbara Sumberg

**TRAINERS.** See *Sneakers*.

**TRANSVESTISM.** See *Cross-Dressing*.

**TRAVEL CLOTHING** Travel clothing hardly existed as a separate category of dress until the nineteenth century, when new forms of travel beyond horse, carriage, and sailing ship were developed, and when the Industrial Revolution permitted mass production of fabrics, enabling more classes to afford garments that were designed for specialized and infrequent use.

Prior to that, both urban and rural poor and middle-class people did little traveling and relied on whatever

outer garments they possessed to protect them from dirt, dust, and the elements. Boots, cloaks, coats with extra shoulder capes, and wide-brimmed hats were available to men riding on horseback or in uncovered vehicles. Upper-class men traveling by horseback relied on the same garments. When traveling in carriages, women in the seventeenth and eighteenth centuries could wear a wool riding habit, more easily cleaned than fashionable silks. The cane-framed calash, a high, folding bonnet, introduced in the late eighteenth century, protected women's high hairstyles from the dust of travel; women's iron pattens worn over shoes also protected from dirt and mud.

Generally, however, the condition of roads, and the lack of leisure time for most people, prevented much travel except among the gentry classes. After 1800, more people could afford travel, with the development of public conveyances like canal boats and stagecoaches (old forms, but increasingly used in America) and new inventions, steamships and trains. Travelers were concerned not only with protection from dirt (soot and sparks from coal engines on trains and steamships, dust and mud on carriages), but about appearing in public among strangers—particularly a concern for middle-class women.

Canal travel was not particularly dirty, but its shared sleeping, bathing, and dressing quarters required its users to pack carefully so that propriety and modesty could be respected. Canal boats offered ladies' bathing and dressing rooms not necessarily connected to their sleeping quarters, so women were advised to pack a full-length, modest dressing gown. Men were expected to sleep in their shirt, trousers, and shoes, removing coat, waistcoat, collar, and cravat.

Railway travel had similar concerns and solutions. With limited room for luggage, a smaller holdall was needed for the duration of the journey. The "shawl strap" was a recommended and seemingly popular solution: a change of clothes and undergarments was spread on a large square of sturdy linen or wool, the edges folded over the clothes, and the whole rolled up and bound with two leather straps.

Steamship travel for leisure was not extensive until the last quarter of the century. The combined effects of seawater and soot from the smokestacks were ruinous to clothes, and during most parts of the year, decks could be chilly. Accordingly, warm, enveloping overcoats were recommended, particularly Ulsters, and fine clothes discouraged. Some guidebooks advised wearing old clothes that could be discarded after the journey. Others addressed seasickness, suggesting women wear dresses that could be donned with minimum effort. Shared bathrooms accessed by a walk down a corridor required, as had canal boats and railway cars, modest wrappers.

Small cabins required packing a minimum of clothes for the journey, allowing the remainder of the luggage to stay in the hold. Steamer trunks, unlike the vast trunks

designed to hold the many bulky items in a women's wardrobe for an extensive foreign journey, were only twelve inches high and fit under the cabin's berth. The "shawl strap," beloved of railroad journeys, was often suggested as ideal for the transatlantic trip.

Travel clothing, when referring to extensive foreign travel, takes on two categories: what to wear on the voyage, and what to pack to last for the rest of the trip. Once the rigors of the steamship were over, travelers could resume normal dress, but guidebooks offered comprehensive packing lists, unanimously advising traveling light. Women were advised to bring a few sturdy undergarments without delicate trim to withstand hotel laundries, and a minimum of outfits—the black silk dress and wool tailored suits being top recommendations. Even when travel became more luxurious, women were advised to wear outfits uncluttered by trims and flounces, which were difficult to keep tidy and clean. The tailored outfits that entered women's fashions in the 1870s were ideal for travel.

Travel to tropical climates required specialized equipment such as pith helmets to protect from the sun (with veiling for women) and khaki-colored linen and cotton being logical fabrics and colors in dusty, sandy places. Green-lined parasols—green was thought to protect the eyes—and green sunglasses were also necessary accoutrements.

By about 1900, travel by both sea and rail had become less dirty. Fashion advice for travelers addressed matters of etiquette more than practical issues. Travel costume merely had to fit within pre-existing codes of dress: "The boat is the country, and the train [is] town in the morning," *Vogue* had only to declare in June of 1925, and its readers knew precisely what was proper (p. 58).

Travel by automobile was, in its early years, more of a sport than a mode of travel, and as such its specialized clothing need not be discussed at length here. Open cars required long linen dusters and goggles for both sexes as protection from dust, and ladies wore veils over their hats for some protection from sun, wind, and dust. A uniform emerged for chauffeurs, and long "car coats" kept passengers warm; later in the century, the "car coat" was by definition short, for convenient movement by the driver.

Choosing clothes for airplane travel was also largely a matter of etiquette. While choosing fabrics less likely to wrinkle and show dirt was always a concern, flying in an enclosed cabin did not require specialized clothing. However, luggage design had to adapt to the weight restrictions of airplane travel, and aluminum and smaller suitcases quickly replaced the heavy steamer and other trunks used in railway and steamship travel. Lately, travelers' desire to forgo checked luggage has led to the design of wheeled bags conforming to size restrictions for overhead or under-seat stowing. Additionally, the democratization of travel led to a decline in use of porters, further incentive for designing lightweight, convenient bags.

The later twentieth century saw innovations in synthetic fibers and fabrics useful to travelers seeking clothes that resist wrinkling when packed or worn, take little space in a suitcase, and can be washed in a hotel sink and hung to dry, avoiding costly and time-consuming laundering by a hotel—or easily done in less luxurious locales, as modern travelers venture into locations beyond the traditional centers of culture that were the destinations of nineteenth-century voyagers. Travelers can also purchase garments and gadgets to ease both their airplane journey and the rest of their travels, including specialized toiletry bags and packing organizers; reversible, wrinkle-proof, drip-dry, less bulky dresses and skirts; and garments suited to hot climates.

See also **Outerwear**.

#### BIBLIOGRAPHY

- Cooper-Hewitt Museum. *Bon Voyage: Design for Travel*. New York, 1986. Exhibition Catalogue.
- Dunbar, Seymour. *A History of Travel in America*. Indianapolis, Ind.: Bobbs Merrill, 1915.
- Knox, Tomas W. *How to Travel: Hints, Advice, and Suggestions to Travelers by Land and Sea*. New York: G. P. Putnam's Sons, 1887.
- Ledoux, Kate Reed. *Ocean Notes and Foreign Travel for Ladies*. New York: Cook, Son, and Jenkins, 1878.
- Luce, Robert. *Going Abroad? Some Advice*. Boston: Clipping Bureau Press, 1897.
- O'Brien, Alden. *Don't Leave Home without It: Travel Clothing in America, 1840–1940*. Unpublished Master's Thesis, Fashion Institute of Technology, New York, 1989.

Alden O'Brien

**TREACY, PHILIP** Born in rural Ireland in 1967, Philip Treacy was the second youngest of eight children of a baker in the Galway village of Ahascragh. He initially studied at the National College of Art and Design in Dublin in 1985 before moving to London to study millinery at the Royal College of Art. His acclaimed graduate show in 1990 resulted in offers to collaborate with international designers such as Valentino, Versace, and Karl Lagerfeld at Chanel, with whom he worked for ten years. The first hat he designed for Chanel was the twisted birdcage, photographed by Patrick Demarchelier for the cover of *British Vogue*. The same year he established his own company, Philip Treacy Limited, and went on to win the title of Accessory Designer of the Year at the British Fashion Awards in 1991, 1992, and 1993 and again in 1996 and 1997.

The dramatic power of his designs has meant that they appeal to extraordinary, iconic women such as Isabella Blow and Grace Jones. Renowned for her ability to spot and nurture talent, Isabella Blow is probably the most extreme showcase for his work. She first encoun-



tered his hats when working with the fashion editor Michael Roberts at *Tatler* magazine, and on Treacy's graduation invited him to set up a workshop in the basement of her house on Elizabeth Street, Belgravia, London. In 1994 he opened his own shop at 69 Elizabeth Street. Among Blow's other protégés was Alexander McQueen, with whom Philip Treacy collaborated in 1999 on his haute couture collection for Givenchy, which included hats constructed from gilded rams' horns.

Philip Treacy identified 1993 as the year that signaled a new attitude to millinery, resulting from the production of his first annual catwalk show at London Fashion Week. The showcasing of millinery as a design item independent of garments has led to a revival of interest in the wearing of hats. According to Isabella Blow (2003), "In the old days, people were frightened by my hats. But in the last year, or maybe two, Philip has single-handedly broken through the barriers."

Treacy has transformed the hat into an art form. His signature style of playful surrealism allied with complete mastery of the craft skills inherent in millinery has resulted in a unique reputation. Drawing on diverse subjects, from orchids to Andy Warhol, Philip Treacy continues to receive universal acclaim from both fashion press and buyers. Although his couture designs may be extreme in concept and not suitable for everyday wear, Treacy also designs a ready-to-wear line which retails through department stores, and in 1997 he launched an accessory collection that includes hair ornaments, scarves, bags, and gloves.

In 2000 he was invited by the *Chambre Syndicale de la couture*, the governing body of French fashion, to participate in the haute couture show, the first millinery designer to do so in seventy years. Evidence of the broad appeal of his aesthetic, Treacy exhibited at the Florence Biennale in 1996, and in 2001 he collaborated with artist Vanessa Beecroft on an installation at the Venice Biennale. In 2002 the Royal College of Art awarded him an honorary doctorate.

See also **Extreme Fashions; Hats, Women's; Milliners.**

#### BIBLIOGRAPHY

- Blow, Isabella. "Tasmin Blanchard 'Blow by Blow.'" *The Observer* (23 June 2003).
- Blow, Isabella, Philip Treacy, and Hamish Bowles. *Philip Treacy: When Philip Met Isabella*. New York: Assouline Publishing, 2002. An exhibition catalog.

Marnie Fogg

**TRENDSETTERS** Functionally, clothes provide warmth and protection. Socially, clothes express status and identity. The first trendsetters were members of the ruling class, particularly monarchs and aristocrats. Queen

Elizabeth I, for example, adorned herself as if her person were the state, creating an unassailable image for herself as Britain's monarch. Similarly, Louis XIV of France dressed to impress, and also set rules regulating what members of the court aristocracy were to wear. By the eighteenth century, however, trends were increasingly set by individuals in urban centers, such as Paris and London, rather than at court.

In the mid-nineteenth century, the wife of Napoleon III, working with the couturier Charles Frederick Worth, set fashions for an eclectic array of *nouveaux riches*, social climbers, old aristocrats, and members of the *demimonde*. Women of the *demimonde* were often entertainers, actresses, and dancers, as well as courtesans. In some ways, they were precursors of modern stars.

By the beginning of the twentieth century, theatrical stars such as Sarah Bernhardt were joined by film stars such as Clara Bow, Marlene Dietrich, and Greta Garbo in setting sartorial trends. For example, the ballroom dancer Irene Castle helped to popularize the post-World War I trend for short hair when she cut her own hair in a "Castle bob." By the early 2000s, actresses remained among the most important trendsetters, joined by pop singers such as Madonna, arguably the most trendsetting woman of the twentieth century.

Fashion magazines—notably *Vogue*—have also played an important part in launching "the Beautiful People" as celebrity trendsetters. Among them were girls of good family, dressed and posed and photographed by fashion editors and photographers. The 1957 film *Funny Face* starred the gamine Audrey Hepburn, whose character lived out the transformation from duckling to swan.

What is a trendsetter? A woman put on a pedestal, an icon that others want to follow. In magazines, they fall into a few categories: the society girl (Gloria Guinness, sometimes known as "the swan," and Babe Paley); the model girl (Jean Shrimpton, Veruschka, Kate Moss); the entertainer (Katharine Hepburn, Sarah Jessica Parker). Gabrielle (Coco) Chanel is a rare case of the designer as trendsetter, since she was the best model of her own clothes.

The qualities these women possess include beauty, status, and larger-than-life personas. In the late twentieth century, models gave way to the phenomenon of supermodels, who commodified trendiness through brand association. Actresses also became associated with particular styles and designers. Trendsetters have become figures thrown into the light by the flare of the paparazzo's flash. Whereas yesterday's social elite had money and status, and actresses and models had beauty, contemporary trendsetters possess a lifestyle (encompassing fashion) that whets the appetite of a global public.

See also **Actors and Actresses, Impact on Fashion; Celebrities; Supermodels.**

## BIBLIOGRAPHY

- Howell, Georgina. *Vogue Women*. New York and London: Pavilion Books Ltd., 2000.
- Keenan, Brigid. *The Women We Wanted to Look Like*. New York: St. Martin's Press, 1978.
- Shakar, Alex. *The Savage Girl*. New York: HarperCollins, 2001.

Laird Borrelli

**TRICKLE-DOWN** The “trickle-down” theory offers a straightforward way of predicting fashion diffusion: a hierarchical process whereby individuals with high status establish fashion trends, only to be imitated by lower-status individuals wearing cheaper versions of the styles. Subsequently, high-status individuals become motivated to differentiate themselves by moving on to a new trend. Initially based upon an explanation of social-class dynamics within western modernity, the theory has since been applied to gender and age relations.

The origin of the theory is generally attributed to sociologist Georg Simmel, although he was actually only one of several writers (e.g., Spencer, Grosse, Veblen) who sought to explain fashion through class structure and social mobility in the late nineteenth century. Through a contemporary lens, Simmel (like others of his day) placed an inordinate emphasis on social class in his explanation of fashion (see Blumer; Davis; Crane). However, in many ways Simmel's analysis was especially nuanced in its blend of psychology and philosophy; it can be read as elaborating a fundamental blend of imitation and differentiation that surpasses social class alone (Lehmann; Carter).

Carter (2003) suggests that a modern scientific goal of assigning order to a seemingly disorderly phenomenon (fashion) led to the restricted (economic-based) naming and life of the trickle-down theory. The historical evidence of such an orderly trickling-down fashion is not very convincing (see Breward; Crane). By the late 1960s, the theory had come under attack, as class-based explanations could not explain the number of styles that bubbled or percolated up from working-class youth or diverse ethnicities (Blumer; King). Furthermore, the speed with which fashion could be “knocked off” in cheaper versions had accelerated to the point that any trickling that occurred was blurry. Indeed, in the twenty-first century's global economy, counterfeit versions of high-fashion handbags appear almost simultaneously with “original” handbags, on the sidewalks outside designer stores in major cities around the world.

McCracken (1985) attempted to rehabilitate the trickle-down theory by relating it to gender. He noted a process whereby women imitate men's fashions in order to obtain more status, only to be usurped by further changes in men's attire. Although McCracken has been critiqued for not demonstrating the differentiation function (on the part of men) adequately, if one goes back to Simmel's analysis, it is possible to establish how the di-

alectical process of fashion simultaneously articulates twin opposites in a single “masculine” or “feminine” look.

More recently, Huun and Kaiser (2000) demonstrated how the basic elements of imitation and differentiation can explain changing infants' and young children's fashions—in terms of age, as well as gender. And, Cook and Kaiser (2004) reinterpreted the trickle-down theory to explain the recent “downsizing” of teen and adult fashion into children's and “tweens” styles. Although the hierarchical (class-based) flow of the trickle-down theory may be challenged in many ways, the basic dynamic underlying Simmel's analysis of imitation and differentiation remains a critical part of fashion theory.

See also **Veblen, Thorstein**.

## BIBLIOGRAPHY

- Blumer, Herbert. “Fashion: From Class Differentiation to Collective Selection.” *Sociological Quarterly* 10 (Summer 1969): 275–291.
- Breward, Christopher. *The Culture of Fashion*. Manchester, U.K.: Manchester University Press, 1995.
- Carter, Michael. *Fashion Classics: From Carlyle to Barthes*. Oxford, U.K., and New York: Berg Press, 2003.
- Cook, Daniel, and Susan B. Kaiser. “Be Twixt and Be Tween: Age Ambiguity and the Sexualization of the Female Consuming Subject.” *Journal of Consumer Culture* 4, no. 2 (2004): 203–227.
- Crane, Diana. *Fashion and Its Social Agendas: Class Gender, and Identity in Clothing*. Chicago: University of Chicago Press, 2000.
- Davis, Fred. *Fashion, Culture, and Identity*. Chicago: University of Chicago Press, 2002.
- Huun, Kathleen, and Susan B. Kaiser. “The Emergence of Modern Infantwear, 1896–1962: Traditional White Dresses Succumb to Fashion's Gender Obsession.” *Clothing and Textiles Research Journal* 19, no. 3 (2001): 103–119.
- King, Charles W. “Fashion Adoption: A Rebuttal to the ‘Trickle-Down’ Theory.” In *Toward Scientific Marketing*. Edited by S. A. Greyser. Chicago: American Marketing Association, 1963, pp. 108–125.
- Lehmann, Ulrich. *Tigersprung: Fashion in Modernity*. Cambridge, Mass.: MIT Press, 2000.
- McCracken, Grant. “The Trickle-Down Theory Rehabilitated.” In *The Psychology of Fashion*. Edited by Michael R. Solomon. Lexington, Mass.: Heath, 1985.
- Simmel, Georg. “Fashion.” *American Journal of Sociology* 62 (May 1957): 541–558.

Susan B. Kaiser

**TRIGÈRE, PAULINE** Born in Paris in 1908 to Russian-Jewish émigrés, Pauline Trigère grew up behind the shop where her mother and father, former tailors of military uniforms for the Russian aristocracy, worked in the clothing trade. By age ten she was help-

ing her mother with dressmaking tasks. Triguère was apprenticed at age fifteen to the couture house Martial et Armand on the place Vendôme, where she quickly showed her aptitude for tailoring and a mastery of the bias cut. In 1929 she married Lazar Radley, a Russian immigrant tailor; the couple had two sons. In 1935 she opened a small wholesale business specializing in tailored suits and dresses. Concerned about the Nazi threat, the Radleys left Paris in 1937, stopping in New York on their way to Chile. At the urging of the designer Adele Simpson, Triguère decided to stay in New York, and was hired first by Ben Gershel, then as Travis Banton's assistant by Hattie Carengie. In 1941 the Radleys opened a tailoring business with her brother, Robert, that closed when Lazar Radley left his wife and sons.

In January 1942 Pauline and Robert opened another business with a collection of eleven pieces. Robert sold them from a suitcase across the country, receiving orders from many important retail stores. In order to buy fabrics for that first New York collection, Pauline borrowed \$1500 and sold some diamond jewelry for \$800. Within three years her name was widely known. During nearly sixty years in business, she garnered many honors: three Coty Awards, inclusion in the Coty Hall of Fame, the Neiman Marcus and Filene's awards, the City of Paris silver and vermeil medals, and the French Legion of Honor. In addition, she was inducted into the Hall of Fame of the Shannon Rodgers and Jerry Silverman School of Fashion Design and Merchandising at Kent State University (1990); was given a retrospective fashion show to honor her fifty years in business at the Fashion Institute of Technology in New York (1992); received the Council of Fashion Designers of America's Lifetime Achievement Award (1993); and had a retrospective exhibition (1994) at the Kent State University Museum, the repository of several of her earliest garments and sketchbooks that chronicle each of her collections. Also in 1994 she closed her ready-to-wear business and formed a new company, P. T. Concepts, to market her scarves, jewelry, and other accessories. She died in 2002.

Triguère provided her own witty commentary during her fashion shows. She did not design by sketching, but rather cut and draped fabric directly on a model. The finished garment was later sketched as a record. She was noted especially for her elegant tailoring, innovative cut, frequent use of the bias, and sensitivity to fabric, line, and movement. Fur-trimmed evening dresses became a signature look. She was also the first major designer to use an African American model. Known as an intellectual "designer's designer," Triguère shaped her career as surely as she shaped her creations: with a strong sense of personal style. "Fashion is what people tell you to wear" she said (Epstein, p. 19). "Style is what comes from your own inner thing" (Nemy, p. C14).

See also **Fashion Designer; Russia: History of Dress; Tailoring.**



**Pauline Triguère.** Renowned for her attention to line, tailoring, and cut, fashion designer Pauline Triguère created her designs by using fabric and a model rather than by first drafting sketches. © MITCHELL GERBER/CORBIS. REPRODUCED BY PERMISSION.

#### BIBLIOGRAPHY

- Epstein, Eleni Sakes. "Triguère." In *American Fashion: The Life and Lines of Adrian, Mainbocher, McCardell, Norell, and Triguère*. Edited by Sarah Tomerlin Lee. New York: Quadrangle/New York Times Book Company, 1975.
- Milbank, Caroline Rennolds. *New York Fashion: The Evolution of American Style*. New York: Harry N. Abrams, Inc., 1989.
- Nemy, Enid. "Pauline Triguère, 93, Exemplar of American Style, Dies." *New York Times* (15 February 2002): C14.

Jean L. Druesedow

**TRIMMINGS** A band of colorful ribbon, a silken tassel, a row of buttons, a flash of sequins—trimmings can add texture, color, drama, and visual interest to clothing and accessories.

Prior to the Industrial Revolution, garment trimmings were generally available only to the elite, who flaunted costly dress accents such as gemstones, fine lace, or egret plumes to signify their high social status. In the early 2000s, trimmings of all kinds are manufactured worldwide, from South America to Southeast Asia, and





### **LIBERACE: TRIMMED TO THE NINES**

For his final performance at Radio City Music Hall in 1986, the famed showman Liberace (1919–1987) appeared in a series of elaborate ensembles completely encrusted with pearls, sequins, bugle beads, rhinestones, and ostrich feathers.

are available to all. They constitute a substantial portion of the total international fabric industry's sales, and are used in quantity by makers of evening wear, bridal wear, childrenswear, youth fashions, uniforms, costumes, and millinery.

#### **It's All in the Details**

Fabric trimmings such as lace, braid, cord, piping, embroidery trim, and fringe are most frequently used literally to “trim” a garment by attaching them along the edge of the sleeves, hem, collar, or bodice. Trimmings in this category can be made from natural fibers such as cotton, linen, silk, wool, rayon, or raffia, as well as from polyester, nylon, and other manufactured fibers.

Lace is a delicate openwork fabric made of yarn or thread in a weblike pattern. In the sixteenth and seventeenth centuries, the great demand for handmade linen and silk lace for apparel as well as domestic and church use gave rise to major lace-making centers in Antwerp, Brussels, Chantilly, Valenciennes, Venice, and elsewhere. A machine for making lace came into wide use by the 1840s, and the production of most lace today is done by machine, with modern varieties like eyelet lace and stretch lace available.

Braid, cord, and piping can be made from solid colored or metallic thread, or from groups of different-colored threads braided or twined together. They are a salient trimming on military, parade, and police uniforms, especially for dress occasions. Embroidery trim (as distinguished from embroidery done directly on a garment) is sold in bands of machine-embroidered floral or geometric motifs, popular for childrenswear. Another form of embroidery trim is a ribbon-banded style called a “jacquard,” a notable detail on Tyrolean clothing. Fringe, which is also sold in bands, is a favorite trim on cowboy-style Western wear and garments affecting a rustic look.

#### **Glitter and Glamour**

Spangles, sequins, and rhinestones are often used to trim evening wear and theatrical or holiday costumes. Spangles and sequins—factory-made, small, shiny metal or plastic disks (or other shapes)—can be sewn over the en-

tire surface of a garment, or added to limited areas to add sparkle and color. The show-stopping gowns by designer Bob Mackie (1940– ), who has been called the “sultan of sequins,” stand out for their exuberant surface application of sequins, rhinestones, and other glittering elements.

The imitation gemstones called rhinestones are made of glass, paste, gem quartz, or crystal that has been cut and polished to provide high reflectiveness. Rhinestones can be attached to a garment by sewing or ironing on individual stones, or stitching on pre-made bands or patches. The Austrian company Swarovski is especially noted for its lustrous, faceted lead-crystal rhinestones in bold colors.

#### **The Milliner's Art**

Ribbons and bows are perhaps the most common hat trimmings, though they can be used to trim clothing as well. Contemporary ribbon styles are available in gros-grain, satin, silk, velvet, beaded, wire-edged, floral, pleated, polka dots, stripes, and more.

Individual items that lend themselves to hat trimming include feathers, artificial flowers, pom-poms, and tassels. In nineteenth- and early twentieth-century England and America, a cottage industry of hat trimmers kept workers busy, since no self-respecting woman would appear in public without an artfully trimmed hat. Indeed, some hat styles would not be complete without their particular trim: the pom-pom on the tam-o'-shanter, or the tassel on the fez, for example.

The decorative use of bird feathers was practiced in Pre-Columbian America and Polynesia, as seen in elaborate feather work headdresses and capes from Mexico, Hawaii, and New Zealand. In eighteenth-century Europe, tall plumed headdresses called “aigrettes” enjoyed a vogue among society women. In the twenty-first century, pheasant, turkey, rooster, and ostrich feathers are often used in millinery design, though concerns about the exploitation of rare birds have curbed the resale of imported feathers.

Artificial flowers have been a favorite trimming for millinery and haute couture since the nineteenth century. To create fake flowers, manufacturers treat silk, organza, cotton, chiffon, or velvet with a stiffening agent, dry the fabric, die-cut the petals and leaves in a press, and then paint or dye them for final assembly. Of note are the exquisitely lifelike blossoms made for four generations by Guillet of Paris, whose high-end clients include Lanvin, Emanuel Ungaro, and Christian Lacroix.

#### **Buttons and Beads**

Since antiquity, buttons have been made from a variety of materials including bone, metal, stone, wood, and shell. Besides being utilitarian fasteners, buttons can be sewn to a garment as a pure surface ornament. At the annual Pearly Kings and Queens harvest festival in London, buttons-as-trimmings take the spotlight as “royal”

revelers sport elaborate costumes covered from head to toe with mother-of-pearl buttons.

Beads of clay, stone, and glass have a long history, used as a clothing or hair decoration in diverse cultures for centuries, from the Copts in Egypt, to the Benin and Yoruba tribes in Africa, to the Plains Indians of North America. Hand-beading in the contemporary garment industry is often the domain of couture houses, where lavish beaded creations by designers such as John Galliano (1960– ) require long hours of careful stitching. Beading is also a major element in bridal wear, especially in the use of white seed pearls to decorate wedding gowns and headpieces. Affordable mass-produced forms of beaded trim include bands, patches, and fringe.

See also **Beads; Braiding; Buttons; Feathers; Knotting; Lace; Ribbon; Spangles.**

#### BIBLIOGRAPHY

- Ashelford, Jane. *The Art of Dress: Clothes and Society, 1500–1914*. New York: Harry N. Abrams, 1996.
- Fleming, John, and Hugh Honour. *The Penguin Dictionary of Decorative Arts*. London: Viking, 1989.
- Geoffrey-Schneiter, Berenice. *Ethnic Style: History and Fashion*. Paris: Assouline, 2001.
- Martin, Richard, ed. *Contemporary Fashion*. New York: St. James Press, 1995.
- Specter, Michael. "The Fantasist: How John Galliano Changed Fashion." *The New Yorker* 22 September 2003.
- Thrush, Elizabeth. "Made in Paris: Flower Child." *France Magazine* Fall 2003.

Kathleen Paton

**TROUSERS** Bifurcated lower-body garments made from textiles, fabric, or leather have existed since ancient times, and trousers rank among the most fundamental pieces of clothing. Ankle to calf-length trousers, wide or narrow, with seamed or wrapped legs were part of the costume of the ancient Chinese, Mongols, Sythians, Phrygians, and Persians. The Sarmatians, the Dakerians, and the Lydians presumably adopted them, after 700 B.C.E., from the Persians. Trousers-clad equestrians seem to have played an important role in their diffusion; even attempts at accurate fitting can be traced back to riding. Depictions of the stocking-like leg coverings, featuring stripes, dots, checks, or zigzag lines, of Asia Minor's soldiers and male and female riders, can be found on ancient Grecian ceramics. The Celts, Germanic peoples, and the Sarmatians were the first to wear the *truss*, a sort of linen undergarment, in the late Bronze and Iron Ages. High-high and ankle-length trousers, sometimes luxuriously woven and artistically sewn out of fabric and leather, are documented as being worn by men and occasionally women of northern tribes.

The Greeks and Romans of the Classical period thought of trousers as the "garb of the Barbarians," from



**Models display gray trouser suits.** The trouser suit has remained the standard outfit of business for men and, by the early twenty-first century, was widely accepted attire for women in business as well. AP/WIDE WORLD PHOTOS. REPRODUCED BY PERMISSION.

whom they vehemently strove to distinguish themselves. When, in the second and third centuries C.E., Roman soldiers, and later, common people, began to adopt trousers for practical purposes, it was forbidden to wear them on pain of punishment in Rome. However, after the fall of the Western Roman Empire (fifth century C.E.), Roman dress no longer set the standards for all of Europe. *Beinlinge* (separate, unattached coverings for each leg) with *trusses* (a kind of short undergarment) became common throughout Europe. In the early and high Middle Ages, leg coverings—woolen, fastened to the belt of the *truss*, under long clothes or short tunics—served as protection from cold and as functional clothing. Women as well wore leg coverings in cold weather or when traveling.

After 1350, the demand for male leg coverings altered dramatically: as a result of the change in knights' armor from chain mail to plate armor; leg coverings had to fit the contours of the body more closely. The leggings became a second skin and—in response to the style of extremely short men's doublets—were made into a sin-



**Movie stars model trousers, 1933.** Actresses Marlene Dietrich (at left) and Bebe Daniels broke the fashion rule that women should not wear trousers. Trousers were not widely accepted as conventional women's wear until the 1970s. © BETTMANN/CORBIS. REPRODUCED BY PERMISSION.

gle garment by attaching wedge-shaped inserts or fly flaps. The stocking-like hose of the fifteenth century, with its attached feet and heraldic patterns, may be regarded as the first veritable men's trouser fashion. It is, moreover, the first fashion where men and women went their separate ways, men adopting short tunics and hose, and women keeping to their long skirts.

This conspicuous marking of gender, through skirt and trousers respectively, continued in Western culture until quite recently. The identification of man and trousers became universal to such a degree, that trousers, in images and figures of speech, have evolved into symbols for man and manly strength. (See for example numerous prints and caricatures on the theme of the "battle of the trousers.") From the fifteenth century until the late nineteenth century, women very rarely donned men's trousers.

The stylish man's bifurcated garment changed its appearance countless times. At first, Italian sheath hose, with their limited freedom of movement, were widened with a slit; in 1500 the garment was separated into knee breeches, laced at the waist, with stockings attached to the breeches. From these developed, in the early sixteenth century, extremely broad, heavily slashed wide breeches lined with colorful fabrics and worn by the mercenary

soldier. Despite all regulations (sumptuary laws), and public mockery (pamphlets, satirical drawings), extra wide, heavily slashed and flashily decorated breeches with fantastically padded codpieces remained the fashion during the sixteenth century. In Spain, after 1550, fashionable men began to overstuff their wide breeches, which in turn shortened them greatly, creating two balloon-like legs. Spanish trousers, so-called "military bass-drum pants," were worn in national variants throughout Europe, without codpieces after 1600. During the Thirty Years War (1616–1648), knee-length, extremely wide pantaloons, with decorative side buttons and ribbons, were introduced by the French; these developed, after peace was declared, into the skirtlike, heavily decorated Rheingrave, or petticoat, pantaloons (1655–1680). This extreme form of the 1670s was eventually replaced by the simple *culotte*, worn as part of Louis XIV's court attire. The *culotte* was the obligatory part of men's suits until the French Revolution. During the Revolution the *culotte* or breeches were replaced by the long pantaloons or trousers of working-class men.

Simple knee breeches, fastened at first under the knee with ribbons and then later with buckles or buttons, were worn by most upper-class men in the eighteenth century until they began to be replaced during the French Revolution by the long work pants of working-class revolutionaries (the *sans culottes*—"without breeches," so-called because they wore trousers instead). The trousers of the first half of the nineteenth century had varying styles; some were extremely tight, others were broadly pleated trousers (Russian or Cossack pants), and sharply flared, below-the-knee *matelot* trousers. In the 1830s, trousers were long, close fitting, and equipped with straps that fit under the soles of the feet. In the 1850s, pants legs were looser, and the old trouser fly was replaced by a concealed, buttoned middle slit. The former relatively colorful palette grew increasingly sober from the 1860s on, as dark colors and plain materials became usual in everyday and evening clothing. At the beginning of the twentieth century, pleats and cuffs completed the development of the daytime and evening trouser. At the same time, men's sports and leisure clothing became a field for experimentation with the development of knickerbockers, jeans, Bermuda shorts, chinos, and other styles.

The 1880s represent the first considerable public presence for women's trousers. In the 1840s a minority of women, such as Amelia Bloomer, had demanded a "right to trousers" which had been briskly denied. By the 1880s, however, women bicycle riders in pantaloons, bloomers, or trouser-skirts had become visible in many cities in Europe and North America. By the early twentieth century, trousers for women existed for various leisure activities. The couturier Paul Poiret, for example, launched trousers as fashionable dress for women and caused a great scandal. After World War I, however, when people got used to women in trousers, society accepted fashionable pants as beach-wear or exclusive evening suits.



And yet trousers for women still instigated scandals. Marlene Dietrich, for example, caused an uproar by wearing trousers in Hollywood and Europe. It was only in the 1970s that trousers finally won a secure place in the spectrum of women's clothing. Since then, trousers have become acceptable as women's business, recreation, and evening clothing. In cultures outside Europe, one may trace entirely different fashion traditions. Thus in cold climates, such as Siberia, the indigenous inhabitants developed an "arctic" garment, made of a combination long-sleeved jacket and long trousers of leather or fur, which is virtually identical for both men and women. The "tropical" clothing type, featuring wraparound skirts, also recognizes few gender differences, although sarongs and other wrapped garments tend to be tied differently for men and women. In the traditional dress of many Asian peoples, trousers are often seen on women and dresses are seen on men. Arab, Persian, Syrian, and Turkish women wear traditional leg-coverings, as do Cossaks, and Tatars. In Scotland, on the other hand, the kilt is an emphatically masculine garment.

In the context of spreading globalization, long trousers are gradually coming to replace the traditional masculine dress of cultures outside of the European context. The business suit, a standard in European and American fashion since the nineteenth century, is presently becoming a worldwide norm, and women in most of the world can wear trousers without being accused of being masculine.

#### BIBLIOGRAPHY

- Benaim, Laurence. *Pants, Trousers: A Walking History*. Paris: Vilo Publishing, 2001.
- Martin, Richard, and Harold Koda, eds. *Jocks and Nerds: Men's Style in the Twentieth Century*. New York: Rizzoli, 1989.
- Polhemus, Ted. *Street Style From Sidewalk to Catwalk*. London: Thames and Hudson, Inc., 1994.
- Wolter, Gundula. *Die Verpackung des männlichen Geschlechts. Eine illustrierte Kulturgeschichte der Hose*. Marburg: Jonas Verlag, 1991. A history of men's trousers.
- . *Hosen, weiblich. Kulturgeschichte der Frauenhose*. Marburg: Jonas Verlag, 1994. A cultural history of women's trousers.

*Gundula Wolter*

**T-SHIRT** From its origins as men's underwear to its complex role in modern fashion, the T-shirt is today one of the most universally worn items of clothing. Cheap, hygienic, and comfortable, the T-shirt has become an essential basic wardrobe item worn by people of all social classes and ages. Technically, the T-shirt evolved and proliferated at an astonishing rate, aided by the increased availability of American cotton and the invention of the circular knitting machine in the mid-nineteenth century. Its current shape and style developed during the 1930s and it became universally worn as an outer-garment after World

War II. In 2004 over two billion were sold worldwide. Contemporary versions range from inexpensive multi-packaged units to haute couture editions to high-tech fiber versions used in sports and health industries.

Shirts of T-shaped construction were worn as early as the medieval times to protect the body from chafing by heavy, metal armor. Civilians adopted the shirt as a protective and hygienic barrier between the body and costly garments. Made of cotton or linen, the shirt was more easily washable than silk or woolen outer garments with complex ornamentation. These shirts were made with long tails that wrapped around the body serving as underpants. The shirt was still always worn with a waistcoat or vest and jacket over the shirt. Wearing a clean, laundered shirt showed off a gentleman's wealth and gentility. Shirts changed very little in shape from their introduction in medieval times through the mid-nineteenth century. They were loose fitting, made of a woven fabric, and constructed with rectangular pieces that formed a T shape.

In the late nineteenth century when health-oriented concerns became prevalent, doctors and physicians advised wearing warm undershirts to protect from colds and rheumatism. Dr. Jaeger lauded the healthful benefits of wearing knitted underwear made of wool and manufactured his own line of knit undershirts. The circular knitting machine patented in 1863 made it possible to mass-produce knit jersey undershirts and hosiery for wide distribution. This technology created a greater range of types and refinement in undergarments. Its closer fit looked more like the modern T-shirt than earlier loose-fitting, woven shirts.

Sailors in the nineteenth century wore white flannel undershirts under their woolen pullovers. These shirts were worn alone on deck for work that required freedom of movement. The white cotton knit T-shirt was adopted as official underwear for the U.S. Navy in 1913. Fast drying, quick, and easy to put on, sailors responded positively to the new garment. The U.S. Army adopted it in 1942, in its classic form. Nicknamed skivvies, each soldier's name was stenciled on. In 1944 the army colored the shirt khaki to camouflage with the extreme tropical environment of the South Pacific. The vast media coverage of World War II popularized the T-shirt as a symbol of victorious, modern America and glorified it as a masculine, military icon. Returning soldiers retained the style after the war because of its comfort, practicality, and image. A Sears, Roebuck and Co. catalog slogan in the 1940s took advantage of the heroic image that had developed during the war, "You needn't be a soldier to have your own personal T-shirt." Since that time it has been used in every war and has been appropriated by paramilitary factions. Like the trench coat it has also become an integral part of civilian dress from street fashion to haute couture.

Fruit of the Loom was the manufacturer who began marketing T-shirts on a large scale in the 1910s, first

supplying the U.S. Navy and then universities with white T-shirts. The company manages its own cotton fields and yarn production. Each shirt undergoes 60 inspections before it is packaged. From the rebels of the 1950s to preppies who paired them with pearl necklaces in the 1980s, the company remained a number one producer of T-shirts through the 1990s and is still a competitive brand. The P. H. Hanes Knitting Company, founded in 1901, introduced a new style of men's two-piece underwear. They have been a major supplier of T-shirts to the military and to the Olympics in addition to vast civilian distribution.

An increase in sports and leisure activities gave rise to new forms of clothing in the latter part of the nineteenth century. Close-fitting knitted woolen swimsuits made in the tank-shaped style of undershirts accustomed the eye to seeing more skin and one's body shape in a public place. By the 1930s T-shirts were standard sporting wear at colleges and universities. The earliest shirts printed with school logos served as uniforms for school sport teams. These sport uniforms encouraged a new casualness in dress among the middle classes that was important to the T-shirt's general acceptance. The cotton T-shirt has remained a mainstay of sports activities because it is absorbent, quick-drying, and allows free range of movement. The T-shirts' role in sports has moved beyond team identification and practical function; it is crucial to the marketing, promotion, and profitability of the sports industry.

In post-World War II years, the T-shirt was primarily worn for athletics, informally at home, or by blue-collar workers for physical labor. Marlon Brando's portrayal of Stanley Kowalski in *A Streetcar Named Desire* (1951), wearing a visibly sweaty T-shirt clinging to his musculature, captured an erotic power of the shirt. The strong associations of masculinity developed earlier in patriotic form in military images, now had an amplified sexual expression. The silver-screen images of Marlon Brando in *The Wild Ones* (1953) and James Dean in *Rebel Without a Cause* (1955) embodied the spirit of American youth in the 1950s. The impact of these movies was profoundly influential on society in solidifying a language and image of rebellion. Through these movies the white T-shirt, blue jeans, and black leather motorcycle jacket became the uniform of nonconformists searching for meaning in conservative postwar consumerist society. Other important musicals, films, and television programs from *West Side Story* (1961) to *Happy Days* (1974) to *American Graffiti* (1973) repeated and confirmed the rebellious meanings. Young people recognized this style as a new American fashion. Administrators prohibited wearing the T-shirt to school in an era when most people still wore shirts with collars. Not only was it rejected because of its informality, but the knit quality of the T-shirt is more clinging than a shirt or blouse. The Underwear Institute declared in 1961 that the T-shirt had become a dual-purpose garment that was acceptable as both outer-

wear and underwear. In the early 1960s, a female image was promoted in the pivotal French film, *Breathless* (1960). Jean Seberg was featured as a young American selling the *Herald Tribune*, wearing a white T-shirt silk-screened with the newspaper logo that showed off her curvaceous figure and at the same time embodied a new, youthful androgynous style of seduction and feminine power. This film did much to introduce the style into female fashion. The erotic aspect of the T-shirt has been exploited in wet T-shirt contests that not only make use of the clinging quality of the fabric, but also its semi-transparency when wet.

Since the late 1960s and 1970s, the T-shirt has evolved and proliferated at a rapid rate. Decorative techniques used to create expressive statements on T-shirts became popular from the 1960s onward. Graphic designs, novelty patterns, and written words lionize rock 'n' roll bands, promote products and places, and express political and community-minded causes. Rapidly made and inexpensive, imprinted T-shirts can respond quickly to popular and political events. The first political use was in 1948 when the Republican candidate Thomas Dewey distributed T-shirts that read "Dew it with Dewey." The graphics for one of the most printed and widely copied designs, "I Love New York," was created in 1976 by graphic artist Milton Glaser.

Technological advancements in inks used for silk-screen printing in the early 1960s made this ancient technique easy, inexpensive, and fast. Underground artists who were decorating surfboards and skateboards on a cottage-industry level were some of the first to put designs on T-shirts. The shirts were an inexpensive canvas for expression. The hot iron transfer technique introduced in 1963 was even easier and faster to use. The fast-heat pressure-press widely available in the 1970s gave consumers the ability to choose the color of the shirt and its image or wording, and have it custom prepared in the store within minutes. In a 1976 *Time* magazine article, a Gimbels department store executive claimed that the Manhattan store sold over 1,000 imprinted shirts a week. Current digital processes allow for the printing of complex images with a professional appearance. Flocking, bubble coating, and embroidery are all used to create textured designs. With these two techniques the design area is coated with glue and then dusted with fibers that are attracted by electrostatic means that affix them perpendicularly to the surface of the fabric leaving a velvety surface. Embroidered designs, whether done mechanically or manually, can be enhanced with beads, sequins, feathers, and other materials.

Community-minded causes were print designs that were most popular in the 1960s and 1970s. Images and messages about the Vietnam War, Civil Rights, peace and love, and feminist movements were prevalent. "Make Love Not War" and "Save the Whales" were two of the most popular messages. British designer Katherine Hamnett created a revival in T-shirts bearing political written messages in 1984 when she wore an oversized T-shirt

bearing the message “98% of people don’t want Pershings” in a public meeting with British Prime Minister Margaret Thatcher at the height of the Falklands War.

More than a passing fad, imprinted T-shirts have become an integral part of brand marketing, whether distributed as promotional gifts or to generate revenue. In 1939, Metro-Goldwyn-Mayer used the T-shirt to promote one of the first color movies made in Hollywood, *The Wizard of Oz*. Budweiser started stamping its logo on shirts in 1965 but it was the following decade that the idea was spread to all types of brands, from Bic to Xerox. In the case of the Hard Rock Café, collecting logoed T-shirts from its locations around the world has become a significant portion of the draw to the restaurant.

In 1983 the *New Yorker* reported that the industry sold 32 million dozen items in 1982. Although there are fads for different styles and colors, the imprinted T-shirt is unique in that men, women, and children of all ages, shapes, and social standings universally wear it.

Pop artists Andy Warhol, Keith Haring, and Jenny Holzer pioneered the use of the T-shirt as a work of art. In the 1980s contemporary fashion’s inclusion in museum exhibitions considered the many designer versions. Also in the 1980s, with the explosion of marketing of museums, masterworks of art were reproduced on T-shirts and sold in their gift stores.

High fashion adopted the T-shirt as early as 1948. A model appeared on the cover of *Life* magazine and ran a story that featured T-shirts by American designers Claire McCardell, Ceil Chapman, and Valentina. The article demonstrated how the sports shirt was now a street and evening style. The 1960s saw it go from street fashion to silk haute couture versions in the collections of such designers as Pierre Balmain and Christian Dior. From Woodstock to Yves Saint Laurent Rive Gauche to Vivienne Westwood, by the 1970s the T-shirt was part of all sectors of dress. Logoed shirts by Lacoste and Polo Ralph Lauren of the 1980s and 1990s were popular indicators of status. The black T-shirt became the uniform of the trendy and hip in the 1980s. Bruce Weber’s photos of models wearing Calvin Klein’s T-shirts became an icon of 1990s sexuality and minimalism. Designers such as Donna Karan, Giorgio Armani, Tom Ford, Jean Paul Gaultier, and Helmet Lang have worn the T-shirt as their own identifying uniform. Designer shirts are usually made from a high-quality cotton, have an elegant neckline, and well-cut and sewn sleeves. Japanese designers Issey Miyake and Yohji Yamamoto have led new ways of thinking about the T-shirt in their deconstructionist work through cutting, slashing, and knotting. Miyake’s vision has ranged from his Janice Joplin and Jimi Hendrix T-shirt of the 1970s to his piece of cloth shirts by the yard of 1999. The T-shirt has been pivotal to the revolution in lifestyles and attitudes that formed the second half of the twentieth century and its impact on fashion continues.

See also **Politics and Fashion; Sportswear; Underwear.**

#### BIBLIOGRAPHY

- Bayer, Ann. “What’s the Message on Your T-Shirt?” *Seventeen* (April 1981): 186–187.
- . “1951 T-Shirt.” *Life* (16 July 1951): 73–76.
- . “T-Shirts: Sports Standby is Now a Street and Evening Style.” *Life* (7 June 1948): 103–106.
- . “Imprinted Sportswear.” *New Yorker* (11 April 1983): 33.
- Brunel, Charlotte. *The T-Shirt Book*. New York: Assouline, 2002.
- Harris, Alice. *The White T*. New York: HarperCollins, 1996.
- . “The T-Shirt: A Startling Evolution.” *Time* (1 March 1976): 48–50.
- Russell, Mary. “The Top on Top.” *Vogue* (March 1983): 316–317.

Dennita Sewell

**TURBAN** The turban is essentially a headgear that uses fabric of varying width and length, which is twisted and turned around the head. The wrapped folds derived produce a “fitted effect” akin to a stitched or an engineered head covering. Though length, style, color, and fabric may vary as geographical locations change, the basic concept and construction of the turban remains unaltered. This is probably the widest and most flexible definition of this garment considering the many forms in which it exists.

Little is conclusively known of the origins of the turban. The earliest evidence of a turban-like garment is from Mesopotamia in a royal sculpture dating from 2350 B.C.E. Thus, it is known that the turban was in use before the advent of Islam and Christianity, therefore the origin of the turban cannot be ascribed to religious reasons alone. It is also mentioned in the Old Testament and Vedic literature from India. Sculpture from Central India (100 B.C.E.) provides detailed visual evidence of the use of turbans. These headdresses were originally worn by royalty and spiritual leaders and used to commute power, often being adorned with jewels and accessories to display wealth and grandeur.

In some form or another, the turban has been important in many cultures and religions. It is still in use in rural areas in Persia, the Middle East, Turkey, parts of Africa, and the Indian subcontinent where wrapped, as opposed to stitched headgear, continues to be preferred. Historically, draped clothing has always had a special significance in eastern culture. Watson notes that “certain strict Hindus still do not wear cut or stitched cloth as for them a garment composed of several pieces sewn together is an abomination and defilement” (p.11). Though turbans are worn primarily by men, literary evidence reveals that they were used by women on rare occasions in the past. “In Vedic literature Indrani, wife of Indra, wears a headdress known as usnisa” (Ghuyre, p. 68). Some of the earliest terms for the turban in English are *turbant*, *toliban*, and *turband*. These represent the



French adaptation of the Turkish *tulbend*, a vulgarism for the term *dulbend* from Persia, *didband*, a scarf or sash wound around the neck.

In India this headdress is known by many different names locally. *Potia*, *usnisa*, *pag*, *pagri*, *safa*, and *vesbtani* are some of the names used for the turban. The Sikhs, a community that dictates its followers to wear the turban, call it *dastaar*, while the Muslim religious leaders refer to it as the *kalansuwa*. In the earliest times, cotton was the fabric most commonly used as turban material. This is because it was affordable and abundant, apart from being the most comfortable fabric to use in tropical or temperate climates where it was most worn. Fabrics such as silk and satin saw limited usage among the more affluent and powerful class. Though there are innumerable variations in the turban, they can easily be divided into two broad types—long turbans and square turban pieces. The long piece is seven to ten meters long with the width varying from twenty-five to one hundred centimeters. The square pieces could vary in size between one to three meters per side, with one to one-and-a-half meters constituting the most useful size. There are an amazingly wide variety of turbans across different cultures and religions. Distinctions are made on the basis of size, shape, material, color, ornamentation, and method of wrapping. In the Muslim world, religious elders often wear a turban wrapped around a cap known in Arabic as a *kalansuwa*. The shape of these caps can be spherical or conical and this produces variations in the turban shape. In Iran, leaders wear black or white turbans wrapped in the flat, circular style. In the Indian state of Rajasthan the style of turban may vary even within the distance of a few miles. The Rajput turbans are remarkably different from the kind worn in any other region in India. There are specialists called *pagribands* whose skill is in the art of tying the turban and were employed by the erstwhile royalty for their services. Some famous styles from Rajasthan are the *Jaipur pagri* and the *Gaj Shabi* turban, the fabric of which is dyed in five distinctive colors and was developed by Maharaja Gaj Singh II from the Jodhpur royal family.

The turban as a headdress is not merely a fashion statement or cultural paraphernalia; it has symbolic meaning beyond the obvious. It serves to identify the wearer as a member of a particular group, tribe, or community, and serves as an introduction to their cultural, religious, political, and social orientations. Sikh men commonly wear a peaked turban, that serves partly as a covering for their hair, which is never cut out of respect for God's creation. The turban has significant associations with the concepts of respect and honor. A man's turban is supposed to signify his honor and the honor of his people. The exchange of turbans is considered a sign of everlasting friendship, while presenting someone with a turban is considered a great token of esteem. An exchange of turbans also signifies a long relationship and forges relationships between families. Thus, the turban is an intrinsic part of all ceremonies from birth until death.

Conversely, it is considered a grave insult to step over or pick up another man's turban. It is linked intrinsically to the "ego" of a person. To remove a turban and lay it at another's feet symbolizes submission and an expression of humbleness. The turban at a glance conveys the social and economic status of the wearer, the season, festival, community, and the region. It is also distinctive by the style of wrapping—each fold telling its own story. The tightness of the drape of the headgear, the lengths of the hanging end, the types of bands which are created on the surface, all say something about its wearer.

The colors of turbans vary in different cultures and are imbued with complex connotations, emotional context, and rich association. They are used to convey mood, religious values, customs, and ceremonial occasions. In India, ocher is the color of the saint, saffron denotes chivalry, and prosperity. White turbans, considered by some Muslims to be the holiest color, are used for mourning and by older men, whereas dark blue is reserved for a condolence visit. Among Sikhs of north India, blue and white cotton turbans are essentially religious in nature. In the Middle East, green turbans, thought to be the color of paradise, are worn by men who claim descent from the prophet Muhammad. Shape and size of the turban are determined by many conditions. Chief among these are the climate, status, and occupation of a person. Turbans are big and loose without hanging tails in the hot desert and thus serve a protective function. Merchants involved in more sedentary activities would wear ornamental turbans with long hanging tails.

The turban was introduced into fashionable European dress in the early fifteenth century and its usage continued until the sixteenth century. It has been revived many times in women's fashion at intervals since the sixteenth century. The turban has acquired a more contemporary form in the twenty-first century. Though it continues to exist in various parts of the world in its more traditional form, of late various fashion designers and couturiers have adapted the turban to give it a more fashionable and chic look, making it a popular fashion accessory. Even though in its more contemporary form the turban may not retain the same symbolism that is attached to its more traditional form, it nevertheless reinforces the importance of this garment.

See also **Headdress**.

#### BIBLIOGRAPHY

- Bhandari, Vandana. *Women's Costume in Rajasthan*. Ph.D. diss., Delhi University, 1995.
- . "Mystical folds: The Turban in India." *Fashion and Beyond* (October 2001): 22–25.
- Boucher, Francois. *A History of Costume in the West*. London: Thames and Hudson, Inc., 1987.
- Ghurye, Govind Sadashiv. *Indian Costumes*. Bombay: Popular Book Depot, 1951.
- Mathur, U. B. *Folkways in Rajasthan*. Jaipur: The Folklorists, 1986.

- Nagar, Mahender Singh. *Rajasthan ki pag pagriyan*. Jodhpur: Mehranarh Museum Trust, 1994.
- Singh, C. et al. *The Costumes of Royal India*. New Delhi: Festival of India in Japan, 1988.
- Watson, John Forbes. *The Textile Manufacturers and the Costumes of the People of India*. Varanasi, India: Indological Book House, 1982. Originally published in London in 1866.
- Yarwood, Doreen. *The Encyclopaedia of World Costume*. London: B. T. Batsford, Ltd., 1988.

Vandana Bhandari

**TUXEDO** Throughout the twentieth century, the tuxedo was emblematic of occasions when men were requested to dress formally after dark, whether for drinks, dinner, or some other gathering. The garment developed at a time in the late nineteenth century when men in the upper levels of society began to demand that their clothes be cut to accommodate the increasingly casual nature of leisure time. As with many fashion innovations, credit for the new style of jacket intended to be worn by men in the evening was claimed by many individuals. In fact the tuxedo jacket arose from sartorial innovations in both America and England. It succeeded in ushering in a new level of formality, intermediate between full white-tie formal wear and the lounge suit, that is only now showing signs of fading from usage.

The term tuxedo derives from Tuxedo Park, a residential club colony of rustic mansions in the outer suburbs of New York, founded in 1886 by the wealthy Lorillard family and some of their friends. The Tuxedo Club's annual Autumn Ball was an important event in the New York social calendar; the dress code for the ball would normally have been white-tie and tails. However, in 1885 James Brown Potter, a charter member of the Tuxedo Club and friend of the Lorillard family, had been introduced to the idea of the dinner jacket by the Prince of Wales, who was later to become Edward VII. The Prince had recently created a new evening jacket to be worn at his country estate at Sandringham; it was a black jacket without tails, inspired by the smoking jackets that men would wear when retiring to the smoking room after a meal. A year later, Pierre Lorillard and his son Griswold had their tailor design similar dinner jackets with satin lapels, with a cut similar to the equestrian jackets worn for fox hunting. These "Tuxedo jackets" soon caught on as the customary attire for semiformal evening events in New York society.

In a separate development, the French responded to the need for a lighter semiformal jacket for warm Mediterranean evenings by creating the Monte Carlo. Although all of these developments show the influence of sporting, hunting, and leisure dress as a means of modernizing a garment by the simplification of its attributes and by the easing of bodily restriction in its cut and construction, it is from the American sense of casualness in formality that the tuxedo derives most of its meaning.

As an alternative to the black tailcoat, the tuxedo was differentiated from the lounge jacket through a fairly strict definition of what constituted it and what it could be worn with. Principally in black, the jacket could bear peak lapels or a shawl collar faced in either silk or grosgrain, and was matched to a pair of trousers with a plain silk stripe running down the side of each leg, without turned-up cuffs. The obligatory furnishings of a black bow tie and cummerbund (when worn without a waistcoat) did not become fully established until the 1920s. At that time, too, the Duke of Windsor refined the narcissistic possibility of the tuxedo by having a dinner jacket made in midnight blue. Ever conscious of his own appearance, the Duke had noted that under artificial light, midnight blue seemed blacker than black. Better still, it also registered darker in photographic terms on newsprint giving the garment the weight of royal authority executed as a self-conscious exercise in style.

The co-option of the tuxedo by women from the late 1960s on indicates a performative sense of playfulness, transgressing the costume's once rigid gender implications. Yves Saint Laurent's *le smoking* (named after the French term for the tuxedo) was launched in spring 1967 as the singular concept for his entire couture collection. Saint Laurent's technique was to soften the tailoring while retaining the angularity of the cut which, when accessorized with stiletto heels and dramatic makeup, formed a contradictory image of femininity without compromise. This proposition is most clearly articulated in a photograph by Helmut Newton where a woman, unaccompanied in a street at night, pauses to light a cigarette. As a statement of style it is unsurpassed. All designers who have followed on from this deviation, including Ralph Lauren's form-following tuxedo suits, Giorgio Armani's textured interpretations, and Viktor and Rolf's historical pastiches, underline the singular importance of this sartorial appropriation in women's dress as expressive of modernity.

The modulations in the details of the tuxedo across the postwar period are reflected in the sartorial taste of the literary and filmic figure James Bond. More than any other figurehead, Bond has been the model that most men have looked to when considering a style of tuxedo when occasion demands. Sean Connery's depiction of Bond in early films such as *Dr. No* (1962) and *Diamonds Are Forever* (1971) crystallized an early 1960s sensibility of a black "tux" with lean lapels, satin cuffbacks, covered buttons, and a folded white handkerchief in the top pocket. The clipped and minimal detailing was suggestive of both acumen and agility in a louche world to which many men aspired. The contradiction is that Bond is better known in the public imagination for the white rather than the black tuxedo jacket, necessitated by the range of tropical settings and number of casinos that the character frequented.

The other institution that upholds the suitability of the tuxedo for special-occasion dress is the Oscar ceremony.

As a necessary foil to the elaborate costumes worn by the invited actresses, the tuxedo lends a certain formal gravity to support the very unstable nature of dress designs that appear on the red carpet on a yearly basis. In the vogue for women to reveal the actuality of their bodies in the dresses they wear, the tuxedo becomes the monochromatic means for men to encase the actuality of their own bodies in a formal armor that reveals very little of the true self.

Originating as a relaxed alternative to formal wear, the tuxedo has become emblematic of celebration and special occasions and a potent sartorial symbol of ceremony. When worn well, it conjures up a ritualistic sense of propriety and the debonair expression of a lost era.

See also **Formal Wear, Men's**.

#### BIBLIOGRAPHY

- Curtis, Bryan, and John Bridges. *A Gentleman Gets Dressed Up: Knowing What to Wear, How to Wear It, and When to Wear It*. New York: Rutledge Hill Press, 2003.
- Flusser, Alan. *Dressing the Man: Mastering the Art of Permanent Fashion*. New York: HarperCollins, 2002.
- Hollander, Anne. *Sex and Suits: The Evolution of Modern Dress*. Tokyo and New York: Kodansha International, 1995.

#### Internet Resource

"The History of the Tuxedo." Village of Tuxedo Park official website. Available from <<http://www.votuxpk.com>>.

Alistair O'Neill

**TWEED** Tweed, made from wool and wool mixtures, comes in a phenomenal range of color and weave effects. Originally tweed was made only in the twill weave or variations of that structure. It is debatable whether the name tweed originated from a misreading of an order for *tweel* (Scottish for twill), or whether the cloth is named after the Tweed river in the Borders region of Scotland. However, it is certain that tweed originated in the Scottish woolen industry of the early nineteenth century, where locally crafted woolens were transformed into fashion textiles woven in a factory and sold to national and international markets. This shift of the late 1820s was partly precipitated by the adoption of the black-and-white shepherd's check as a fashionable cloth for men's trousers in the late 1820s.

Trade journals of the period, such as *Textile Manufacturer*, indicate the reputation of Scotch tweed for high aesthetic appeal and quality of manufacture. Interestingly for a branch of the nineteenth-century textile industry renowned for the production of constant novelty and variety in design, the bulk of their cloth was designed for menswear. The origins of the Scottish tweed industry and its success from the 1830s were largely driven by the consumption of cloth for sporting and leisure wear. However, the range of cloths produced including Saxonomies,



"The products of Scottish woolen looms after 1830 were identifiable by three design characteristics—skillful use of color, employment of pure virgin wools, and uniqueness of texture. These factors, combined in a carded cloth, gave tweed its quality and distinctive appearance." (Clifford, p. 75)

Cheviots, and homespun tweeds and the increasing tendency towards informality in male dress meant that by 1900 tweed was also widely worn within a variety of urban contexts, mainly as overcoatings, trouserings and suitings. Saxony tweeds are fine and densely woven and have a soft, smooth handle. They are made from merino wools and the finest versions are indistinguishable from worsted cloths. Cheviot tweeds have a rougher appearance and more open texture than saxonomies, although the lighter-weight versions were widely used as suiting and trousering cloths in the late nineteenth century. The popularity of tweed as a fashionable menswear cloth continued into the twentieth century; however, along with tailoring, it went into relative decline from the 1970s onward.

#### Important Tweed Patterns

Late nineteenth-century tweed patterns include two that are among the few seminal textile designs that have been repeatedly used in both men's- and women's wear since the mid-nineteenth century. The first of these is the Glen Urquhart, a black-and-white check that originated in the early 1840s and which, with the addition of a red or blue over-check, has widely and erroneously been known as the Prince of Wales check. In the United States, the term Glen plaid was used to describe this sporty but elegant cloth, particularly popular from the 1930s to 1960s for men's suitings. The Coigach, which Johnstons of Elgin trace in their records back to 1846, also became widely known throughout the trade. This black-and-brown check, a variation on the simple shepherd's check, was subsequently adopted in the 1870s by a gun club in America, which led to its being universally known as the gun-club check.

#### Expansion and Imitation

The international reputation for design of the Scottish mainland tweed industry led by the late nineteenth century to many imitators and competitors. These included those based in Yorkshire, Ireland (Donegal tweed), and the islands of Harris and Lewis in the Outer Hebrides of Scotland. The Yorkshire woolen manufacturers were among the first to use Scotch-tweed designs as a basis for making cheaper novelty cloths aimed at the mass market. Yorkshire tweeds thus tend to be defined by their place



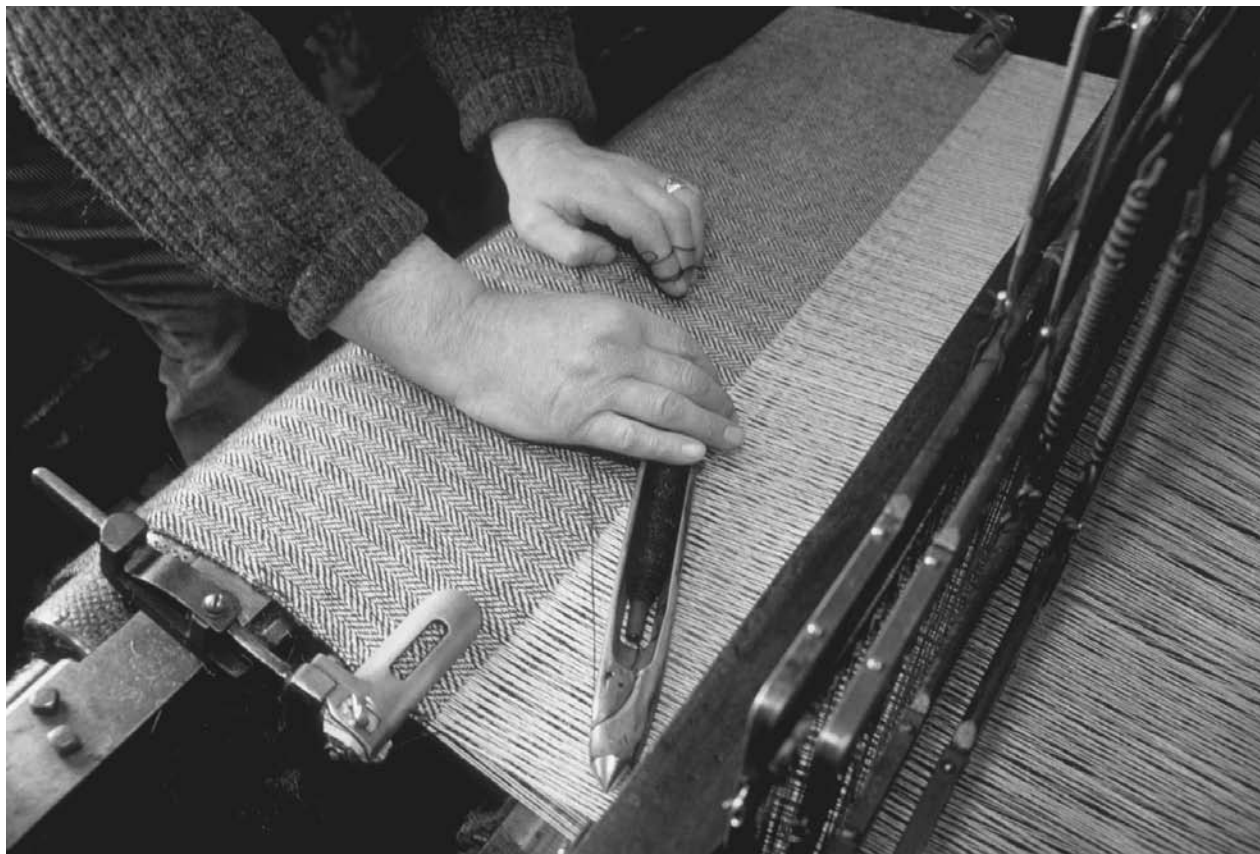

**The weaving of Harris tweed.** Weavers of Harris and Lewis Islands, in the Scottish Outer Hebrides, started producing this coarse, homespun tweed in the 1880s. Designer Vivienne Westwood included this tweed in her fashions during the twentieth century.

© DAVE BARTRUFF/CORBIS. REPRODUCED BY PERMISSION.

of manufacture, rather than by any distinctive visual characteristics. The Harris-tweed industry was established from the 1880s on the islands of Harris and Lewis, through coordination of the efforts of local hand weavers. This coarse-textured, homespun tweed has survived many difficult periods to be championed in the late twentieth century by the designer Vivienne Westwood, whose logo is closely related to the Harris-Tweed Orb label. Donegal tweed also developed in the late nineteenth century and again principally involved hand-woven cloths. Its characteristic salt-and-pepper effect initially came simply from the use of natural undyed wool, until cooperation with the Harris-tweed dyers generated more complex designs.

#### **Tweed in Women's Wear**

From at least the early 1860s, women adopted tweed for outer garments such as jackets, cloaks, paletots, and coats, despite the fact that tweed was predominantly a men's wear cloth. The increasing participation of women in sports, such as countryside walking, shooting, and, later, cycling, led in the 1870s to the development of the tailored costume. This featured a matching jacket and long

skirt that were generally made from some form of tweed. By 1900, the tailored costume had become accepted as informal or sporting wear for women of all classes, despite its earlier connotations of "mannishness" and feminism. The tweed industry, however, did little at this period to adapt its designs for women, other than to make them in lighter weights of cloth.

In the early twentieth century, British couturiers, such as Digby Morton, Hardy Amies, and Charles Creed, helped to stimulate international markets for superbly tailored tweed suits. The French couturier Coco Chanel was also inspired to include it in her collections after traveling to Scotland on a fishing trip with the Duke of Westminster in the 1920s. Her desire to include tweed in her exclusive designs was such that the Duke subsequently bought her a Scottish tweed mill. Linton Tweeds of Carlisle in Northern England has maintained an exclusive relationship with the House of Chanel since 1928. Tweed has since become an integral element of the signature suits that are endlessly reinvented by the House of Chanel.

Contemporary tweed manufacturers aim to maximize the potential of international markets for "traditional

British style” and also to promote their links with the more volatile consumers of radical, innovative fashion. Tweed retains traces of its earlier history in the present, on the one hand as remaining representative of British class and conservatism. However, it also exists as an ephemeral fashion textile that contributes to the rapidly changing visions of designers such as John Galliano at Dior, Alexander McQueen, and Vivienne Westwood.

*See also Chanel, Gabrielle (Coco); Galliano, John; McQueen, Alexander; Scottish Dress; Westwood, Vivienne.*

**BIBLIOGRAPHY**

De la Haye, Amy, and Tobin Shelley. *Chanel: The Couturiere at Work*. London: V & A Publications, 1994.

Gulvin, Clifford. *The Tweedmakers: A History of the Scottish Fancy Woollen Industry, 1600–1914*. Newton Abbot, U.K.: David and Charles, 1973.

Harrison, E. P. *Scottish Estate Tweeds*. Elgin, Scotland: Johnstons of Elgin, 1995.

*Henry Ballantyne & Sons Ltd*. London: Biographical Publishing Company, 1929.

Hoad, Judith. *This is Donegal Tweed Co*. Donegal, Ireland: Shoestring Publications, 1987.

Ponting, Kenneth. “The Scottish Contribution to Wool Textile Design in the Nineteenth Century.” In *Scottish Textile History*. Edited by John Butt and Kenneth Ponting. Aberdeen, Scotland: Aberdeen University Press, 1987.

Taylor, Lou. “Wool Cloth and Gender: The Use of Woollen Cloth in Women’s Dress in Britain, 1865–85.” In *Defining Dress: Dress as Object, Meaning and Identity*. Edited by Amy de la Haye and Elizabeth Wilson. Manchester, U.K.: Manchester University Press, 1999.

*Textile Manufacturer* 15 (January 1878): 2.

*Fiona Anderson*

**TWENTIETH-CENTURY FASHION** Women’s fashion at the beginning of the twentieth century was largely a matter of status. The stylish silhouette was defined by the narrow *sans-ventre* corset, which squeezed away the belly and gave the body an S-shaped line; by the long, sweeping skirt lengths; and by high rigid collars. Textile designs took the lead from art nouveau plant ornamentation. Parisian couturiers, such as Jean-Philippe and Gaston Worth (sons of the first celebrated grand couturier Charles Frederick Worth), the Callot sisters, Jacques Doucet, and Jeanne Paquin, were at the forefront in such society dresses.

This style was diametrically opposed by the “health dress,” propagated by advocates of women’s rights, artistic women, and doctors. This design hung loosely without a corset. Its sack cut was rejected by most style-conscious women, despite the designs of art-nouveau artists like Henry van de Velde.

The suit began to establish itself as a multi-faceted garment, becoming a symbol, eventually, of democratic

fashion. The businesswoman used it in her career and the society lady as a travel and recreation outfit. The jacket was mostly styled in a masculine cut with lapels and cuffs; the frock coat was occasionally shortened above the ankle. Suits were offered by manufacturers as well as posh tailors such as John Redfern and Henry Creed. With the advent of the suit, the blouse became the central style element, featuring both luxuriously decorated and simple models. Comfortable kimono blouses, with cut-out sleeves, could be worn over skirts. Top coats, or paletots, taken from men’s fashion, and carcoats or dusters, satisfied the desire for functional clothing. Around 1908, the Parisian couturier Paul Poiret created a new style called *la vague*. Inspired by the *Ballets Russes*, he combined the body-liberating “health dress” with elements of Asian dress. Paul Poiret had ties with the world-famous Vienna Workshops, which operated their own fashion department.

Originating in England, the Edwardian style (named after King Edward VII) was the leader in international men’s fashion. Men’s fashion was regulated by exact rules, which were published by prominent tailors, as to when and under what circumstances each suit was to be worn.

Business attire included the sports jacket (sack coat) and the more elegant suit jacket. Daytime suites incorporated the frock coat (Prince Albert). The cut-away was considered suitable for more private and prestigious occasions. The smoking jacket fulfilled the role of comfortable, casual evening attire. There also existed specialized sporty ensembles. It was important always to choose the correct hat: soft felt, bowler, homburg, canotier, panama, or top hat. There were also many different coats to choose from, such as paletots, chesterfields, raglans, and ulsters.

**Fashion 1910–1919**

International fashion until 1914 was heavily influenced by the avant-garde French couturier Paul Poiret. He helped initiate the Art Deco style and inspired other designers such as Erté and Mariano Fortuny, whose delphos gowns of the finest pleated silk were also world famous. In 1910 Poiret publicized the hobble skirt, which was, despite its uncomfortable cut, quite fashionable for a short time. It fell loosely, straight to the top of the calf, but was narrowed, from below the knee to its ankle-length hem, with such a narrow yoke that a lady could only hobble. Poiret also proposed a long pants-dress, but few women dared to be seen on the streets in the new *jupes culottes*. For eveningwear, Poiret even suggested broad harem pants worn under a long tunic with a wire-stiffened, upturned hem.

From 1912 until the outbreak of World War I, evening clothes were marked by the new social dance craze, the Argentine tango. Poiret’s creations seemed custom-made for the new popular dance: closely wrapped skirts with high slits in the front, gold-embroidered tunics, and turbans with upright feathers. Men wore the cutaway and the fashionable frock coat, sometimes in strong colors

like dark red, or featuring checkered trim. Accompanying hats were oversized.

During World War I (1914–1918), clothing tended to be as simple as possible: moderately wide skirts, not quite reaching the foot, and hip-length jackets. In 1915–1916, war crinolines—ankle length and fluffed with two or three skirt layers—were *en vogue*; a year later, however, these fell victim to the more economical use of fabric provided by the sack cut. The fashion in 1918 was livened up by large side pockets and skirts that narrowed towards the hem, creating the barrel look of 1919. Most of the fashion salons in Paris had closed. But some wealthy women bought comfortable jersey suits with hip-length jumpers and simple skirts from Gabrielle Chanel in Deauville, thereby establishing her fame. In the United States, especially in New York, clothing manufacturers were active.

The most important novelty of twentieth century women's clothing occurred outside of the fashion world. Long trousers for women were inaugurated, neither by haute couture nor by every-day fashion, but by women's work clothing, which was still mostly borrowed from men. Directly following the war, people worked with what was available, altering uniforms and army tarps or other leftovers, to create civilian clothes.

During the war, the uniform replaced all other suit types, and most tailors—if they stayed in business at all—specialized in its manufacture. After the war, tailors resorted to alterations of uniforms and the reworking of recycled—sometimes fragile—materials into suits which had to be reinforced with buckram, thus creating the so-called starched suit. Men's trousers had very narrow legs all the way to the hem. The trench coat appeared, courtesy of the transition from military into civilian clothes.

### The 1920s

During the 1920s the length of a skirt's hem became, for the first time, a serious fashion question. While the clothes of 1920–1921 were still calf length, and (around 1923) even ankle length for a short time, after 1924 women favored skirts that hardly covered the knee. In 1922–1923, fashion was influenced by the discovery of the grave of the Egyptian pharaoh Tutankhamen. Anyone who could afford it, bought a djellaba for a house dress or had their evening dresses decorated with Egyptian ornaments. Otherwise, loose-hanging dresses were characteristic for the time. Mostly they had drop waists and sometimes a pleated hem or *godet* folds which provided freedom of movement. Daytime clothes had high closings, dressed up with baby-doll or men's collars.

Evening clothes and elaborate society toilettes corresponded in cut to daytime clothes. Evening clothes, however, featured generous front and back décolletage, the front décolletage underlayed with a flesh-colored slip. It was not modern to show one's bosom, and breasts were pressed flat with fabric bands. The simple cut of the

evening dress was compensated for by expensive fabrics of lace, gold or silver lamé, loose hanging pearl necklaces, the use of monkey-fur fringe, and extensive embroidery. In 1927, the tendency to lengthen the evening gown's hem set in and the waist returned to its natural place. By 1928 the evening gown was already calf length, while the daytime dress remained knee length until about 1930.

In haute couture, Gabrielle Chanel made her reputation with dresses, jersey suits, and knit jumpers. In 1926 she announced the “little black dress,” a black evening dress impressive for its simple elegance. Like Chanel, Jean Patou favored clear lines and extremely simple elegance, beginning with his own collection for the United States. Jeanne Lanvin, in contrast, presented a decidedly feminine, romantic line. Her *robes de style* (based on historical styles), with their wide paniers, became world famous. Lanvin was also known for her mother-child creations.

Short skirts brought the legs, and thereby rayon stockings, into the picture. Bobs and page-boy haircuts were as typical of the time as were simple, form-fitting toques and cloche hats. Sports became a fashion trend: tennis in a short skirt without stockings, skiing in a Norwegian suit with long knickers, swimming in a one-piece bathing suit without whale-bone reinforcements. The 1920s metropolitan fashion spectrum included the *garçonne* (female boy) in a pants suit with man's hat and even an Eton crop. In the evenings, the *gamin* style featured a smoking (tuxedo jacket), or complete smoking suit, and a monocle. And the *garçonne* also appropriated men's pajamas for household and nighttime wear.

The Exposition International des Arts Décoratifs et Industriels Moderne, held in Paris in 1925, was an epoch making event which later gave the name Art Deco to the period. Among the seventy-two fashion designers, Sonia Delauney created the biggest sensation with her suits and coats in patterns of “simultaneous color contrast.”

After 1924, men's suits had a slightly tapered waist, and the trousers widened slightly. Dandys were recognizable by their extremely broad trousers, known as “Oxford bags,” and by their exaggeratedly pointed winkle pickers or shimmy shoes. For golf, hiking, or hunting, men wore Norfolk jackets and plus fours.

### The 1930s

At the beginning of the 1930s, clothing was cut to be form-fitting again, with the waist at its natural place. Bodices, with rubber and stretch reinforcements, hugged the body's curves. Shoulder pads and wide lapels, off-the-shoulder collars with flounces, as well as tight belts, all aimed to make the waist appear slimmer. The hem was lengthened with *godet* folds and pleats from the knee to the calf, providing freedom of movement. Evening gowns were preferably of shimmering satin, and reached to the floor, often with a small “mermaid” train. It was *en vogue* to have plunging back décolletage, with wide crisscross-



ing straps, and a waterfall or sweetheart collar. The success of the new body-conscious line can be traced back to the Parisian designer Madeleine Vionnet and her “invention” of the bias cut, whereby material, cut diagonally to the weave, clung to the body and flared out towards the hem like a bell.

Elsa Schiaparelli was not to be outdone on the idea front. In her collections, she worked with *trompe l'oeil* effects as well as allusions to surrealist artists. Schiaparelli's wide pagoda shoulders, invented in 1933, had a major influence on everyday fashion. Suits, jackets, and dresses after 1933 were unthinkable without padded shoulders.

In the fascist countries (Italy, Spain, and Germany), women's fashion became a matter of political agitation, as exemplified by the introduction of the German Girls Club (BDM, *Bund Deutscher Mädchen*) uniform. Alpine costumes also suited the tastes of National Socialist Germany. The world-famous Berlin manufacturers, which had been over 80 percent in Jewish hands, were, for the most part, ruined (i.e., liquidated) due to the “Aryan cleansing.”

The year 1936 was one of the most innovative in men's fashion. The double-breasted suit, with four buttons instead of six, created a furor, as did patterned shirts worn with gray flannel suits. Shirts also featured the new kent collars and somewhat wider cravattes, tied into windsor knots. In daywear, three-button gabardine suit and oxford shirts with button-down collars were common.

### The 1940s

During World War II (1939–1945) and the first years following, fashion was dictated by the need for practical, simple clothes and the rationing of resources and materials. In England the government encouraged “utility clothing.” In Paris, during the German occupation, only very few haute couture houses remained open. In all countries, special magazines and brochures dispensed advice on re-modeling old clothes or how to make new clothes from combining pieces of old ones. Skirts and coats became shorter, suits took on the character of uniforms, and wide shoulders dominated more than ever. Hats and shoes were often hand-made and wool stockings and socks replaced silk. In the United States, Claire McCardell created a furor with her “pop-over” dresses, leotards, and sea-side “diaper suits.”

A new epoch in fashion was marked on February 12, 1947, with the opening of Christian Dior's house. He called his first haute couture collection “Ligne Corolle” (calyx line), but the fashion press called it the “New Look,” because almost everything about it was new. The simple suit jacket, the small lapels, the narrow wasp waist, which emphasized the hips, and, above all, the narrow shoulders. For the first time in over a decade, there were no shoulder pads. Just as new were the extremely wide calf-length skirt, flat broad-rimmed hats (wagon wheels), high-heeled pumps and long gloves, which lent this daytime wear an impressively elegant flair.

At first, due to the lack of necessary materials, the new style could only be produced slowly, but soon countless private seamstresses were busy fulfilling the dream of the “New Look.” In the spring of 1948, Dior's “Ligne Envol” (pencil line) followed, introducing narrow skirts with the famous Dior slit, underlayered with material for walking ease. Nylon stockings were in high demand, leaving shiny rayon and woolen stockings forever in the past.

After the war, a new fashion invention created a lasting impression. On July 5th, in Paris, the French mechanical engineer Louis Réard presented his two-piece bathing suit which he called the bikini. Although there had already been two-piece bathing suits since 1928, Réard's bikini stood out because of its extremely skimpy cut. The bikini, however, was not generally accepted until the late 1960s.

Men's clothing played a rather limited role; uniforms dominated. Trench coats and duffle coats (montys) were all-around coats. The American jazz scene's zoot suit, with its long frock coat and wide trousers, was considered modern.

### The 1950s

In the 1950s Paris regained its position as the capital of fashion. Christian Dior dictated the lines—every season he was ready with another: the H-Line of 1954, for example, which rejected the narrow waist for the first time, and the famous A-Line of 1955. Hardly less influential, however, were the designers Pierre Balmain, Jacques Fath, Hubert de Givenchy, Cristobal Balenciaga, and in Italy, Emilio Schuberth and Emilio Pucci. In 1954, Chanel reopened her salon and advertised an instantly famous suit with a loose jacket and slightly flared skirt in direct contrast to Dior's stiffer, more tailored style. In 1957, with Christian Dior's death, Yves Saint Laurent followed in his footsteps. His trapeze, or tent line, wherein he dared to negate the female figure, was a sensational, if controversial, debut success.

Naturally, women had other concerns besides Dior's fashion dictates, but many private seamstresses took cues from one or another haute couture line. The fashion magazines too adapted elite fashions for the average consumer.

The fashion picture at home and abroad was defined by two basic points: the narrow line with its strong body-consciousness and the attention drawn to the hip line by a gathered waistband, and the broad swinging, youthful petticoat. Both tried to create a dreamy wasp waist, magically narrowed by a corset—the *guepière*—or girdle. In addition to suits and jackets, the shirt dress, with its casual, sporty cut, shirt collar, and cuffed sleeves, was a garment suitable for all occasions.

In cocktail dresses, women favored extreme designs like Dior's cupola or Givenchy's balloon look, whose broad skirt was drawn in sharply at the hem. New synthetic materials like nylon, perlon, dralon, trevira, terylene, elastic, and imitation leather fulfilled the dream of

fashion for all. “Drip dry” and “wash and wear” were the magic words of advertising, relegating the iron to the past. For teenage leisure time, there were jeans, capri pants, and ballerina shoes. The childish-cut short night gown with bloomers, called the baby doll, was new. Aggressively intellectual teenagers were attracted to French existentialism and wore black turtlenecks, tight black leather clothes, and black stockings instead of transparent nylons.

Carefully coordinated accessories were a part of stylish every day wear. Shoes with rounded tips and square heels evolved in 1955–1956 to their famously pointy shape and stiletto heels.

German winter sports fashion became an international model. Maria Bogner’s ski pants, “the Bogner’s,” became a household word in the United States, as did the first one-pieced elastic ski overall, invented by Bogner in 1955.

After 1953, Italy, with its body-conscious suits, began to compete with traditional English tailoring. On the whole, men’s fashions were conservative: nylon shirts were snow white and ties narrow. The Hawaiian shirt was a popular leisure garment. The English Teddy Boys, a teenage fringe group, wore frock coat-like jackets and extremely narrow pants; their hair was styled back over their foreheads in a wave with lotion. The toughs, on the other hand, were known by their black leather outfits.

### The 1960s

The years from 1959 to 1963 were a transition period from the decidedly lady-like style of the 1950s to the teenage style of the ensuing years. Teenagers favored wide-swinging petticoats while the mature woman chose narrow sheath dresses and, as an afternoon or cocktail dress, an extravagantly layered look, with a tight-fitting skirt layered under a shorter tulip skirt. The real 1960s fashion began in 1964. “Swinging London” became the fashion metropolis of the youth. Mary Quant and her little-girlish thigh-length smock dresses made headlines. Her mini-style was not intended to be elitist, but popular; thus she marketed her own fashion stockings, without which the mini was hardly wearable. The sharply-angled Vidal Sassoon hair style was also new. The counterpart to the Mary Quant look was Barbara Hulanicki’s exotic Biba look from London. Twiggy became the most famous mannequin and the “most expensive beanstalk in the world.” Thinness became, from this point on, a requirement of beauty. In 1964, Rudi Gernreich introduced his topless bathing suit, which corresponded to the tendency towards sexual liberation. He also invented the “no bra” brassiere.

Parisian designers participated in youthful unconventionality and ready-to-wear (*prêt-à-porter*) only reluctantly. Yves Saint Laurent presented clothes with large appliquéd pop-art images in shocking pink, a Mondrian collection with contrasting lines and surfaces, and, in

1966, the transparent look. Paco Rabanne created an uproar with mini sheath dresses of plastic and metal discs and Pierre Cardin’s creations featured round holes, “cut-outs,” as well as molded structures. André Courrège’s fashions were the last word in space-age euphoria. His moon maids with silver sequined stretch pants, white synthetic boots, and white sunglasses with slits for seeing, represented pure futurism. His Courrèges-suit, with its geometrically cut jacket and angled cut-out collar, was all the rage. For all opponents of the mini-skirt, trousers were popular in all imaginable forms and lengths, but jeans above all. Pants suits took the place of the traditional suit. Often a super short mini dress would be worn as a tunic over pants. The width of the trouser leg below the knee grew progressively wider. The wider the “bell,” the more stylish.

For a moment in 1965 it appeared as if the younger generation had said goodbye to the mini skirt, as fashion imitated the film “Dr. Zhivago,” with long coats and Russian caps. The hippie and beatnik looks, protesting consumerism, stood in ideological and stylistic opposition to mainstream fashion, and mixed and matched international peasant costumes, like ponchos, Peruvian hats, Eskimo boots, Indian blouses, and Afghani sheepskin jackets. Young people sewed flowers on jeans, wore floppy hats, or showed their naked bodies, painted only with flowers. Creativity was given free reign, under the motto “hand-made is chic”: T-shirts were batiked or painted, jeans embroidered, caps sewn, leather-fringed belts braided, silver jewelry twined, vests crocheted, pullovers knit, but the hippie style was swiftly co-opted by the market.

Pierre Cardin’s high-necked suits without lapels or collars or with small mandarin collars (or “Nehru”) created a furor and were adopted by the Beatles. More radical were the English mods, for whom parkas and Clark shoes were typical. The Beatles’ “mop top” hair-do became a generational conflict. After 1965, men favored the colorful ethnic hippie look. The turtle neck sweater and later the T-shirt substituted for the shirt.

### The 1970s

“Do as you will,” was the fashion motto of the early 1970s. The ideal of the hippies, “we are all equal,” set the tone for unisex and folklore looks. Hand-made was in, from batik shirts, knitted shawls, and crocheted caps, to pullover sweaters of hand-spun sheep’s wool. Understatement was cool and second-hand duds were no longer for the needy alone. The brassiere itself fell victim to the general liberation from all restraints. Feminists spoke of the “liberated bosom.” Directions from high fashion were lacking; even the Parisian designers found themselves in a crisis. Fashion had to be multifarious, uncomplicated, original, and individual, and the hem length varied between mini, midi, and maxi according to whim and mood. Modern romanticism—the nostalgia wave—lent mini-dresses (still fashionable up to 1973), wraparound tops,

wing and flounce sleeves, and bell skirts. Hair was long and softly waved or rolled into corkscrew curls. False eye-lashes or painted-on lines magically conjured star-eyes.

Hardly any other fashion created as big a sensation as hot pants in 1971–1972. They were not only worn as super short summer shorts, but also intended for winter with thick wool socks. Hot pants were offset by the beloved maxi coats and high platform shoes. Pants of all kinds provided a relief from the length disputes. There were tight knee-length caddy pants, broad gauchos, knickers, culottes, harem pants, ankle-length drain-pipe trousers, wide Marlene Dietrich trousers, and—still up to 1974—wide bell bottoms. Jeans became the universal clothing, crossing all class and age boundaries. Jackets, pullovers, vests, and T-shirts clung tightly to the body. Pullover sweaters featured witty motifs like trees, houses, or cars. Maxi length party clothes (evening clothes were out) had bold patterns such as Vasarely graphics, pop-art, or Hundertwasser images.

After 1974, a series of looks followed without constituting a single unified style. In 1975 there were caftans and the Chinese look with short quilted jackets. In 1976 the Middle Eastern look dominated, with tunics over harem pants, and, later, the layered look. A master of the folklore mixture was the Japanese designer Kenzo (Takada), whose Parisian boutique “Jungle Jap,” had a decided influence. Mainstream fashion, on the other hand, was rather conservative, featuring the umbrella-pleated (or gored) skirt, which came to just below the knee.

In 1976 the fashion press euphorically reported on Yves Saint Laurent’s collection “Ballets Russes–Opéra.” It was an elegant peasant look with long, wide skirts of shimmering silk and bolero jackets in unexpected color combinations like red, lilac, orange, and pink, delicate sheer blouses with wide sleeves, and golden turbans.

Beginning in 1977, punk clothing exerted a strong influence on fashion for the next few years. The anti-bourgeois, “no-future” generation shocked with their brutal look: safety pins through cheeks and ear lobes, dog collars and razor blades as necklaces, diabolically made-up eyes, black lips, ripped jeans and T-shirts, torn fish-net stockings, and tough Doc Marten’s boots. Their hair, in contrast to their gray and black get-ups, differentiated itself from the mainstream “normals” by its green and red highlights and its spiked (mohawk) styling. Insiders met at Vivienne Westwood and Malcolm McLaren’s shop on King’s Road, called “Sex” in 1974 and then, later, “Seditionaries” in 1978.

In 1978, the Parisian prêt-à-porter designers, above all Claude Montana, brought the military and punk look onto the runway. Broad “power” shoulders and oversized garments initiated a new fashion silhouette which would become the characteristic style of the 1980s.

The 1975 American book, *Dress for Success* by John T. Molloy, gave the exile from hippie culture tips on how to market himself with the right clothes, on the power of

the white shirt, on how to interpret the codes of tie patterns, and how make it in “big business.” Two years later, in 1977, Molloy’s sequel followed, *The Woman’s Dress for Success Book*.

### The 1980s

The fashion silhouette of the 1980s was defined by oversized, voluminous gigot (leg of mutton) sleeves and wide padded shoulders which coincided with the fight for women’s equal rights. Even eveningwear, which emphasized low-cut necklines and narrow waists, had to have padded shoulders. Hemlines were no longer an issue. Teenagers wore loose mini dresses, but in general skirts extended from below the knee to calf-length. Women wore masculine jackets, short bell-hop jackets or broad-shouldered, box jackets with pants. At the same time, fashion became a sign of prestige and a status symbol, best represented by brand-name labels, and a preference for leather, fur, and gold-colored accessories.

The Japanese avant-garde designers, who attracted a good deal of attention in Europe during the 1980s, stood in sharp contrast to this trend. In the tradition of Japanese clothing, Yohji Yamamoto draped skeins of fabric loosely around the body. In 1981, Rei Kawakubo’s fashion company “Comme des Garçons,” called the entire Western fashion aesthetic into question. She shredded skirts into fluttering strips, tore material, knotted it together, and layered it crosswise. Black and gray dominated. Issey Miyake was known for his highly experimental use of materials and methods, demonstrated by his rattan bodices inspired by Samurai practice armor in 1982, and his first “Pleats Please” collection of 1989.

In 1983, Karl Lagerfeld became the designer for the haute couture house of Chanel. He reworked the legendary Chanel suit to be new and uncomplicated, and added leather skirts and pants suits. Parisian designers offered a new body consciousness as an alternative to the oversized craze. Thierry Mugler sparkled with corset suits and siren clothes, Jean-Paul Gaultier with skin-tight velvet and grenade bosoms, and Azzedine Alaïa with clinging lace-up clothes.

The American designer style became synonymous with sportswear and clean chic. Ralph Lauren gave tradition a modern face lift with his “country-style” concept. Donna Karan was treasured for her functional “all-day fashion” with jersey bodysuits instead of blouses. Calvin Klein was considered the inventor of designer jeans.

The music scene provided more and more style models. Pop icon Madonna was fascinating as a contemporary Marilyn Monroe. Her appearance in a corset was the impetus of the underwear-as-outerwear craze, featuring bustiers and corsets.

The fitness craze exerted the greatest influence on everyday fashion in the late 1980s. The ballet dancer’s leg warmers, the aerobic fan’s leggings, and the bicycle racer’s pants appeared in everyday fashion. Leggings



available in the wildest patterns, the most garish colors, and the shiniest stretchy fabrics, were worn with blazers or long pullover sweaters.

Towards the end of the decade, the long blazer with straight, knee-length skirt and black opaque stockings became the classic women's business outfit. Evening fashion, and the revival of the cocktail dress, was, in contrast, emphatically feminine. Christian Lacroix, whose first haute couture show in 1987 brought a frenzy of color, became the master of cocktail dresses with jaunty, short tutus and balloon skirts.

In response to massive animal rights' campaigns, the wearing of fur became a "question of conscience," making colorful fake furs and quilted down coats fashionable.

Yohji Yamamoto's new men's fashion, with its flowing, collarless jackets, proffered an alternative to the yuppie's conventional shoulder-padded business suit. Giorgio Armani led the rise of Milan menswear, and the German manufacturer, Boss, achieved international recognition for its men's fashions.

In 1982 Calvin Klein revolutionized men's underwear, making simple ribbed men's briefs a designer item by printing his name in the elastic waistband. In 1985, androgyny became a provocative fashion statement; Jean-Paul Gaultier created skirts for the body-conscious man.

### The 1990s

Fashion became a question of "which designer?" with extremely varied styles. In the early 1990s, the Belgian designers Anne Demeulemeester and Martin Margiela started a new style direction with the advent of the grunge and poor-boy look, making Antwerp, which housed designers Dries Van Noten, Dirk Bikkembergs, and Walter Van Beirendock as well, the new fashion center. The English designer Vivienne Westwood finally received international recognition for her daring reinterpretations of historical styles. London newcomers John Galiano and Alexander McQueen established themselves as chief designers at, respectively, Christian Dior and Givenchy in Paris. Jean-Paul Gaultier continued to be very successful with his underwear fashions, particularly with Madonna at its center. The fashion palette of the Italian designer Gianni Versace spanned from neo-baroque patterns to bondage style, while the house of Gucci, under the direction of the Texan Tom Ford, combined purism and eroticism. Miuccia Prada caught on, with her "bad taste" style, and a successful re-launching of past styles. Giorgio Armani remained the master of purism, while Dolce & Gabbana celebrated women's eroticism with black lingerie and animal prints. Jill Sanders, of Hamburg, perfected her minimalism to international acclaim. The Austrian designer Helmut Lang established himself in New York; his transparent layer look and his minimalistic lines gave new stimulus to fashion. Alongside the designers, supermodels, like Claudia Schiffer, Naomi Campbell, Linda Evangelista, and Cindy Crawford, were central to all fashion events.

In everyday fashion, leggings, in all colors and patterns, dominated at the beginning of the decade. Worn under stylishly transparent, calf-length skirts and long blazers in multi-colored blockings, leggings covered the legs discretely. The transparent look appeared somewhat in mainstream fashion, layered over lace bodysuits, bustiers, and bras. Towards the end of the decade, crinkled shirts, ragged hems, and inside-out seams were accepted. The baguette bag, publicized by Fendi, brought the handbag, after two decades of backpacks, into fashion's center stage.

The marketing of brand names became increasingly important: adults favoring Louis Vuitton, Hermes, or Escada, and teenagers of both sexes favoring sportswear brands like Diesel, Chiemsee, Burton, Nike, Adidas, or Levis. The Italian fashion manufacturer Benetton stimulated heated controversies over its advertising.

Men's fashion was also increasingly determined by designers with clearly differentiated styles, ranging from Giorgio Armani's loosely cut suits to Helmut Lang's body-conscious, relatively high-necked suits and narrow trousers with a satin band on their outward-facing leg seams. Baggy pants and extra-large shirts remained popular with the younger generation. Cargo pants were introduced in 1999 as sportswear.

*See also* Armani, Giorgio; Art Nouveau and Art Deco; Cardin, Pierre; Chanel, Gabrielle (Coco); Corset; Dior, Christian; Europe and America: History of Dress (400–1900 C.E.); Gaultier, Jean-Paul; Haute Couture; Lagerfeld, Karl; Lang, Helmut; Patou, Jean; Poiret, Paul; Quant, Mary; Saint Laurent, Yves; Suit, Business; Youthquake Fashions.

### BIBLIOGRAPHY

- Baudot, Francois. *Fashion of the Century*. New York: Universe Publishing, 1999.
- Buxbaum, Gerda, ed. *Icons of Fashion: The 20th Century*. New York: Prestal, 1999.
- Fukai, Akiko. *Fashion. Collection of the Kyoto Costume Institute. A History of the 18th to the 20th Century*. Tokyo: Taschen, 2002.
- Loschek, Ingrid. *Fashion in the 20th Century. A Cultural History of Our Time*. Munich: Letzter Preis, 1995.
- . *Fashion of the Century. Fashion Chronicle from 1900 to Today*. Munich: Letzter Preis, 2001.
- McDowell, Colin. *Forties Fashion and the New Look*. London: Bloomsbury, 1997.
- Remaury, Bruno, ed. *Dictionary of 20th Century Fashion*. Paris, 1994.
- Seeling, Charlotte. *Fashion 1900-1999*. London-Cologne: Konemann, 2000.
- Steele, Valerie. *Fifty Years of Fashion: New Look to Now*. New Haven, Conn.: Yale University Press, 2000.
- Vergani, Guido, ed. *Dictionary of Fashion*. Milan: Baldini and Castoldi, 1999.

Ingrid Loschek

## TWIGGY

**TWIGGY** In 1949 Lesley Hornby, later rechristened “Twiggy,” was born in Neasden, an unfashionable suburb in North London, where she grew up. Only sixteen when she began modeling in 1966, she introduced the cult of the “celebrity model” and left an indelible legacy in other, more significant ways. Models in the 1950s, in both America and Britain, were styled and made up to look mature, sophisticated, and “ladylike,” to complement the fashionable clothes of the time. In England many were young women from respectable families who had followed a modeling course at Lucie Clayton’s Mod-

eling and Grooming School in Mayfair. In America, such top models as Suzy Parker were also well-groomed girls from middle-class backgrounds. New photographic techniques allowed mass-circulation newspapers and magazines to print high-fashion images, and the models’ names soon became familiar to the public.

The social and demographic changes that followed created need for new designs and new models. Mary Quant’s clothes for *Bazaar* were aimed at a young clientele, while the early 1960s saw the opening of innumerable boutiques in London, which, unlike Quant’s shop,



**Twiggy.** Unlike the feminine and sophisticated looks of models in the 1950s, Twiggy became the celebrity model who typified the new, young, and boyish style of the 1960s. © HULTON-DEUTSCH COLLECTION/CORBIS. REPRODUCED BY PERMISSION.

were intended for girls of far more limited means. The first model whose image reflected this climate was Jean Shrimpton. Although she had attended Miss Clayton's school, her success was a result of the partnership she had formed with the working-class photographer David Bailey. The early pictures, which made them both famous, showed off her youth and her tomboy persona.

Lesley Hornby was working as a hairdresser in a salon near her home when an older man recognized the way in which she might personify the new London. Nigel Davies, a former boxer and stallholder, who called himself "Justin de Villeneuve," changed her name and transformed her appearance; it was at his suggestion that she painted on eyelashes under her eyes so as to resemble a porcelain doll and had her hair cut short. The photographer Barry Lategan took a picture for the salon, and, by chance, the fashion editor Deirdre McSharry saw it. In the February 1966 issue of the *Daily Express*, she used a center spread to portray this "Cockney Kid" as "the Face of '66." One of the shots showed Twiggy wearing homemade trousers and sweater, which accentuated both her androgynous appearance and her democratic appeal.

She was smaller than most models and invariably posed so as to emphasize her childlike qualities. In 1967 she was photographed for British *Vogue* by Ronald Traeger, who portrayed her riding a miniature bike in knee-high socks. Cecil Beaton sat her on a high shelf, and Helmut Newton asked her to jump toward the camera with arms outstretched. There followed a shoot with

Richard Avedon and a cover for American *Vogue* in August of that year. At one point she was on twelve covers simultaneously; as a model, she was used by both traditional "glossies" and new, youth-oriented publications.

Although the syndication of her name to dresses, dolls, and other merchandise meant that she could retire from modeling by 1969 to pursue a career as actress and singer, she had permanently changed magazine culture. Now, to the deification of youth was added the idea of instant fame, the notion that class barriers that could be painlessly transcended, and the problematic pursuit of a pre-pubescent ideal of beauty.

See also **Fashion Photography; Fashion Magazines; London Fashion; Quant, Mary.**

#### BIBLIOGRAPHY

- Aitken, Jonathan. *The Young Meteors*. New York: Atheneum, 1967.
- Green, Jonathon. *All Dressed Up: The Sixties and the Counter-culture*. London: Jonathan Cape, 1998.
- Levy, Shawn. *Ready, Steady, Go! The Smashing Rise and Giddy Fall of Swinging London*. New York: Doubleday, 2002.
- Melly, George. *Revolt into Style: The Pop Arts in Britain*. London: Allen Lane, 1970.
- Twiggy. *Twiggy: An Autobiography*. London: Hart-Davis, MacGibbon, 1975.

*Pamela Church Gibson*





**ULTRASUEDE.** See **Nonwoven Textiles; Flocking.**

**UMBRELLAS AND PARASOLS** The origins of the word “umbrella” lie in the Latin *umbra*, meaning shade, while “parasol” comes from the Latin *sol*, meaning sun, and the two words were used interchangeably up until the middle of the eighteenth century (Farrell 1985). Since then, “parasol” has come to denote specifically a shade that protects against the sun, while “umbrella” indicates an item that provides protection from the rain.

Most umbrellas and parasols consist of a central stick to which a number of ribs are attached. The ribs support the cover or canopy and, in turn, they are supported by stretchers from the center of their length to the tubular runner that slides up and down the stick (Farrell 1985). Historians indicate that while umbrellas were always designed to fold, some parasols were made rigid, with the cover consisting of a single circular piece of waxed cloth or taffeta supported on cane ribs.

Umbrellas date from over 3,000 years ago, and according to Crawford (1970), from early times they had religious and mythological symbolism. Most histories of the umbrella and parasol cite Egypt, China, and India as being important geographical locations in the pre-European history of the umbrellas.

In all such cultures where it has had a presence, the umbrella appears to have been associated with high status. Moreover, Stacey notes that: “The Oxford English Dictionary does in fact date the use of the word umbrella from 1653 as ‘an Oriental or African symbol of dignity’” (1991, p. 114).

Many Asian countries have used the parasol in symbolic relation to their dignitaries, and Sangster notes: “In all eastern countries, with the exception of China and Turkey, the Parasol was reserved exclusively for the great men of the land.” (1855, p. 18). According to Crawford (1970), Burma and Siam are two Asian countries that have the most regard for the umbrella as a symbol of sovereignty, and subsequently reports that the ruler of the ancient capital of the Burmese empire had the title of “King of the White Elephants and Lord of the Twenty-Four Umbrellas.” The use of the umbrella as a symbol of respect appears to have continued into the twentieth cen-

tury as Jacqueline Kennedy, widow of the American President John Kennedy, was accorded the privilege of the ceremonial umbrella when she visited Burma in 1967 (Crawford 1970).

In China, too, umbrellas have been used to denote status from as early as the eleventh century B.C.E. Frames at that time were made of cane or sandalwood and the covers of leather or feathers, for wet and dry days (Stacey 1991). During the period of the Ming dynasty (1368–1644), Crawford (1970) notes that ordinary people were not allowed to use umbrellas covered with cloth or silk: they had to use less prestigious items constructed from stout paper. Cheaper East Asian umbrellas are still made of paper manufactured from cotton rags, although better models use paper made from the bark bast of mulberry, which is much stronger. Covers are painted or lacquered and may be decorated with pictorial motifs or auspicious phrases (Crawford 1970).

Evidence of early European use of umbrellas is mentioned by Sangster: “We find frequent reference to the Umbrella in the Roman Classics, and it appears that it was, probably, a post of honour among maid-servants to bear it over their mistresses” (1855, p. 15). However, most historians indicate that the first European umbrellas were probably ceremonial items associated with the pope. There are extant depictions of the Emperor Constantine presenting Pope Sylvester I—who was in office from C.E. 314 to 335—with a brown and white striped umbrella (Crawford 1970) and Pope Eugenius IV (1431–1447) incorporated an *ombrellino* into his coat of arms. Although the emblem is no longer used by the pope himself, it still appears on certain institutions and seminaries (Stacey 1991).

It is likely that trading activity in Asian colonies from the sixteenth century onward ultimately brought the umbrella to wider European attention. Portuguese women in India in the sixteenth century, for instance, would not venture out without an escort of slaves, one of whom bore a shade over his mistress to protect her from the sun and to emphasize her prestige, Crawford (1970) writes. The umbrella subsequently became a custom that returned with the Portuguese to Europe.

The umbrella or parasol started to appear elsewhere in Europe around this time and the French king, Louis



**Asian woman decorating an umbrella.** In many Asian cultures, umbrellas, often painted with decorations, are associated with status and dignity. © BOHEMIAN NOMAD PICTUREMAKERS/CORBIS. REPRODUCED BY PERMISSION.

XIII, is reported to have owned a good number of umbrellas. Between 1619 and 1637 he enlarged his collection to include eleven sunshades made of taffeta and three umbrellas made of oiled cloth trimmed with gold and silver lace (Crawford 1970).

However, the umbrella had no significant presence in Britain until the eighteenth century. Although there are records of some eighteenth century “church umbrellas” designed specifically for use by members of the clergy, the traveler and philanthropist Jonas Hanway is generally credited with introducing the umbrella to London (Stacey 1991). Born in 1712, he traveled extensively to the British colonies and to Europe. On returning to London to carry out his philanthropic work, he was reportedly ridiculed by sedan chair carriers for his use of the umbrella, possibly because they perceived it as a threat to their business (Stacey 1991). Hanway’s now infamous umbrella is most likely to have been French in origin (Farrell 1985).

But it took time for the waterproof umbrella to attain popularity in Britain, perhaps because to be seen with one was regarded as indicative of insufficient funds for a carriage (Farrell 1985). Moreover, Sangster writes that: “The earliest English Umbrellas . . . were made of oiled

silk, very clumsy and difficult to open when wet; the stick and furniture were heavy and inconvenient, and the article very expensive” (1855, p. 31). The ribs of umbrellas at this time were made of whalebone—which lost its elasticity when wet—and the oiled silk or cotton cover would quickly become saturated and leaky. Furthermore, walking-stick umbrellas were uncommon in England in the eighteenth century (although they were being marketed in France), so they generally had to be carried under the arm or slung across the back (Crawford 1970).

In terms of production, Stacey (1991) notes that the first patent was taken out on an umbrella in 1786, and there was subsequently a proliferation of developments with over 121 patents filed in the 1850s alone. But as Sangster points out, “The most important improvement dates from the introduction of steel instead of whalebone.” (Sangster 1855, p. 58). The most successful umbrella designs involving metal ribs were those patented by Henry Holland of Birmingham in 1840, and later by Samuel Fox in 1852 (Farrell 1985).

By the middle of the nineteenth century, there was a thriving umbrella and parasol industry in Britain, and Sangster notes that these items were well represented in

the great exhibition of 1851. In particular, the elaborate umbrella belonging to the Maharajah of Najpoo captured the imagination of visitors and drew attention from visitors: "The ribs and stretchers, sixteen in number, divided the Umbrella into as many segments, covered with silk, exquisitely embroidered with gold and silver ornaments" (1855, p. 63). There is, perhaps, just a hint of umbrella envy in his subsequent statement that "we were glad to find that the visitors turned away from this display of barbaric pomp to the plainer, but more valuable productions of our own land" (1855, p. 63). It was at this exhibition that two of the Sangster brothers, who were themselves umbrella manufacturers, won a prize medal for their alpaca-covered umbrellas. Inferior to silk, but far cheaper and sturdier, alpaca became a highly popular textile for umbrellas in Britain in the 1850s (Crawford 1970).

By the end of the nineteenth century, umbrellas had become less of a novelty and more of an item of convenience. Best quality umbrellas had covers made of silk, cheaper ones of cotton, and green was the most popular color although blue, red, and brown umbrellas were also available. Handles were made of horn, ivory, antler, or wood, and were often decorated with bands of gold or silver (Farrell 1985). By the close of the nineteenth century, *The Tailor and Cutter* reported that "fashionable men are wedded to them" (Stacey 1991, p. 27).

Throughout the eighteenth and nineteenth centuries, manufacturers of quality umbrellas and parasols had their own outlets, while cheaper products were sold in the streets by itinerant vendors (Crawford 1970). Many retailers would offer a repair service as well as new products, and by the nineteenth century there was a healthy trade in refurbished umbrellas (Farrell 1985).

Compared to umbrellas, parasols were light and elegant, and throughout the early nineteenth century a wide range of styles and color were available. They were frequently referred to in magazines and newspapers of the time (Crawford 1970), although parasols were not generally carried by men (Farrell 1985).

Covers were made of chiffon, silk, taffeta, or satin and were often decorated with fringes, lace details, and embroidery. Long wooden bone or ivory handles were elaborately carved to feature animals and insects, porcelain handles were painted with delicate floral designs and some parasol handles even featured gimmicks such as in-laid watches (Bordignon Elestici 1990). Around the mid-1800s, the *en-tout-cas* became popular, as it fulfilled the function of protecting against both the sun and the rain (Farrell 1985), but one of the most remarkable parasols documented belonged to Queen Victoria, which she had lined with chain mail following an attempt to assassinate her (Stacey 1991).

The introduction of the automobile in the early years of the twentieth century initially encouraged the development of driving-specific parasols and umbrellas (Farrell 1985), but the new vehicles probably precipitated the

decline of umbrella use, as people were less often on foot when out of doors (Crawford 1970). However, even during the interwar years (1918–1939), an umbrella was still regarded as "part of the unofficial uniform of a gentleman in London" (Farrell 1985, p. 79).

Although parasols, particularly those that emulated the style of flat, oriental sunshades, were popular up until the 1920s, the growing fashion for tanned skin effectively put an end to widespread use of the parasol by the 1930s. Looking to North America, Stacey notes that "neither the umbrella nor the parasol gained quick acceptance in America (1991, p. 59) and although Sidney Fisher's *Men, Woman and Manners of Colonial Days*, published in 1898, recorded sightings of umbrellas and parasols in Philadelphia in 1771, as a means of keeping off the sun they were reportedly regarded as a "ridiculous effeminacy" (Stacey 1991, p. 59). By the 1950s, however, Americans had championed the "unisex" umbrella, a distinct shift away from the gender-specific umbrella styles of Europeans (Stacey 1991).

The British umbrella trade had flourished in the last quarter of the eighteenth century, as the colonies could be relied on to supply raw materials including canes, whalebone, horn, and ivory, and a thriving textile industry provided fabrics such as silk and cotton gingham for making covers. As a result, by 1851 London had about 1,330 workers in the trade, a third of whom were in the Stepney area of East London. But following the collapse of the parasol market in the 1930s and the domination of the umbrella market by cheap imports from the 1940s onward, the British umbrella industry effectively disappeared (Crawford 1970).

Farrell (1985) indicates that over time, each part of the umbrella and parasol has been the object of improvement, including the innovation of the cranked stick, which allowed the open umbrellas to be centered over the head rather than to one side, and the cycloidal umbrella, which had the stick placed off-center. Since the nineteenth century, however, the only significant structural development has been Hans Haupt's telescopic umbrella in 1930, and improvements to allow automatic opening, but patents continue to be filed at the rate of about twenty a year (Stacey 1991). Use of nylon covers since the 1950s was the only other notable development in umbrella design in the twentieth century (Farrell 1985).

Europe's oldest and biggest umbrella shop continues, in the early 2000s, to trade under the name of James Smith & Sons (Umbrellas) Ltd., which was established in 1830. According to the London and Home Counties Survey (1957), "at one period umbrellas were actually manufactured inside the shop in a space four feet wide, and stock had to be stored in the window," and the company was one of the first to use "Fox Frames" in their umbrellas. In addition to conventional umbrellas, the firm has also specialized in the production of ceremonial umbrellas for traditional rulers in Africa.



Despite its pan-global origins, the umbrella has come to be regarded, in literature at least, as a quintessentially English item, perhaps due to the inclement weather for which Britain is famous. Stacey notes that Max Beerbohm said: "What is an Englishman without his umbrella? . . . It is the umbrella which has made Englishmen what they are, and its material is the stuff of which Englishmen are made" (cited in Stacey 1991, p. 7). In the twenty-first century, however, cheap and poorly made folding umbrellas have become disposable items, displacing durable, high-quality umbrellas in most parts of the world.

See also **Protective Clothing; Raincoat; Rainwear.**

#### BIBLIOGRAPHY

- Bordignon Elestici, Letizia. *Gli Ombrelli* [Umbrellas]. Milan: BE-MA Editrice, 1990.
- Crawford, T. S. *A History of the Umbrella*. New York: Taplinger Publishing Company, 1970.
- Farrell, Jeremy. *Umbrellas and Parasols*. London: B. T. Batsford, Ltd., 1985.
- "Histories of Famous Firms." London and Home Counties Survey (part 4), 1957.
- Sangster, William. *Umbrellas and Their History*. London: Effingham Wilson, Royal Exchange, 1855.
- Stacey, Brenda. *The Ups and Downs of Umbrellas*. Stroud, U.K.: Alan Sutton Publishing, 1991.

Anna König

**UNDERWEAR** The idea of items of clothing being private or public or that a body can be in an appropriately clothed or unclothed state is a relative concept that differs over time and from culture to culture. No tribal society, unless it has been infiltrated by concepts of western dress, appears to have garments that could be considered as underwear: items of clothing that act as a layer of insulation between the skin of the body and its outer garments.

The anthropologist Ted Polhemus uses the example of the loincloth, which is a garment at once in direct contact with the wearer's genitals but at the same time open to the public gaze. He postulates that this intimacy is allowable in small established communities where everything is known of the participants, unlike the rituals followed in larger, more industrialized, and thus anonymous societies. It is only when the cultural notion of privacy is apparent that underwear can perform its ritualistic function of shielding the body from the open scrutiny of others.

It was in ancient Egypt that the concept of having a second layer of clothing between the skin and the outer, more decoratively embellished layer of dress was devised. At that time the inner layer was worn more as a status symbol than for any erotic or practical reasons.

In Europe and North America underwear appears to have developed in range and complexity as the sight of a naked body moves from being an everyday public occurrence to a social taboo, and codes of acceptable social etiquette and civility deem the naked body private. Strategies come into play to make the body respectable, and underwear thus achieves its primary role, to shield the sexual zones of the body from the gaze of others.

Up to the nineteenth century underwear in Europe and North America had two main functions: to protect expensive outer garments from the dirt of the body beneath, as bathing for most was an expensive and time-consuming luxury, and to add an extra layer of insulation. The first items of underwear were unisex and classless linen shifts with no particular erotic connotations. By the nineteenth century, however, the notion of underwear began to change as fashion became more inherently gendered.

Underwear remained practical and functional for men, with cotton being the staple material, but for women it became an erotic exoskeleton helping to achieve the fashionable silhouette by constraining the body and coding certain parts as sexual. The corset, for instance, derived from the *cotte* of the 1300s, a rigid laced tunic of linen, became a device used to compress the waist while simultaneously drawing attention to the breasts and hips. This leads to the inherent tension in the nature of underwear: it conceals but simultaneously reveals the erogenous zones of the body. Adam and Eve may have modestly covered their genitals with fig leaves, but by doing so, they drew attention to the sexual parts of their bodies.

The bra, for instance, supports the breasts but at the same time creates a cleavage, an entirely invented erogenous zone that exists only as a result of the underwear that creates it. Underwear also exists to disguise the messy reality of the functions of the body. On the one hand observers are fascinated by layers of clothing being stripped away but are repulsed when confronted with the traces of the body left behind. As the popular saying goes, "We should never wash our dirty linen in public."

Polhemus sees underwear as preventing what he dubs "erotic seepage" (p. 114) in public encounters, as in the case of men, whose penises are not always subject to voluntary control. Thus the tightly laced corset worn by women (and children up to the late eighteenth century, when the philosopher Jean-Jacques Rousseau advocated their abolition for children) was not just a whim of fashion, it was also believed to lend support to the fragile bodies of women and to constrain their sexuality; women could be "strait-laced" but also "loose."

The corset is also an example of how certain forms of underwear have moved in and out of fashion and have been reworked into different garments that retain the primary function of shaping the body into the fashionable ideal. The couturier Paul Poiret may have declared the corset dead by the 1920s, but it merely went on to as-

some other forms such as the dancing corset, girdle, and the roll-on of the 1950s.

By the 1980s the corset had moved to outerwear through the work of British designer Vivienne Westwood who in her seminal Portrait Collection of 1990 featured photographically printed corsets using the work of eighteenth-century artist François Boucher (1703–1770). She subverted the whole notion of the corset as a physically restricting item of underwear by using lycra rather than the original whalebone or steel stays of the nineteenth-century version. The elasticized sides of Westwood's design meant an end to laces at the front or back. The corset could now be pulled over the head in one easy movement.

By the nineteenth century the range of underwear available for women had become elaborate and its use proscribed by ideas of sexual etiquette to the extent that the accidental revealing of underwear was considered as mortifying as the naked body itself. In 1930 J. C. Flügel in *The Psychology of Clothes* attempted an explanation: "Garments which, through their lack of ornamentation are clearly not intended to be seen (such as women's corsets and suspenders, the coarser forms of underwear) when accidentally viewed produce an embarrassing sense of intrusion upon privacy that often verges on the indecent. It is like looking 'behind the scenes' and thus exposing an illusion" (p. 194). Vestiges of this idea can be seen in contemporary culture, such as the acutely embarrassing state of a man being seen with his trouser zipper down, even if all he will be revealing is his underwear.

In the nineteenth and early twentieth centuries underwear, in some instances, could not be referred to directly in polite conversation, with "unmentionables" being a favored phrase. The twentieth century brought changes, however, including a gradually more relaxed attitude toward both sexuality and underwear.

A key item of women's underwear was developed in 1913 when New York debutante Mary Phelps Jacob, under the name Caresse Crosby, designed one of first modern bras, although the notion of supporting the breasts dates back to the Roman Empire when women wore scarves or *strophium* to mark themselves out from the "barbarous" unfettered breasts of slaves. Jacob's bra was boneless and kept the midriff free, while suspending the breasts from above rather than pushing them upwards from beneath as was the nature of the corset.

Cantilevering was added to bras in the 1950s by firms such as Warner's, who had bought Jacob's original patent, and Triumph, whose cone-shaped, circular-stitched bra in nylon or cotton batiste was worn by the popular Hollywood incarnation of the Sweater Girl as exemplified by stars such as Jayne Mansfield and Mamie van Doren.

In America the union suit held sway for men until the 1930s, when the first shorts with buttons on the yoke, originally developed for soldiers during World War I, became more freely available. The union suit, fashioned

out of knitted fabric that reached from the wrists to the ankles, was one of the first industrially produced items of underwear, and emphasized warmth rather than comfort or convenience. It made no direct reference to the penis—unlike the codpiece, which was less about sexuality and more about rank and status.

However, a massive cultural change occurred in the 1930s when Cooper Inc introduced its Jockey Y-front design with overlapping fly for ease of urination. In the same decade the boxer short, originally issued to infantrymen for summer wear in America during World War I, began its acceptability in men's underwear fashion. The 1960s saw a vogue for brightly colored underwear in nylon and polyester for both men and women, which continued through the 1970s. By the 1980s manufacturers responded to what appeared to be a newly fashion literate male consumer, popularly referred to as the New Man, who was taking a more active interest in his grooming and, concomitantly, his underwear.

Calvin Klein helped in a reworking of masculinity as erotic at the end of the twentieth century with his advertising campaign by photographer Herb Ritts in 1993, using pop-star-turned-actor Mark Wahlberg. Wahlberg was portrayed in Calvin Klein underwear as a powerfully sexual figure, overturning the traditional language of advertising and its representation of male bodies. Wahlberg displayed his semi-clad worked-out body in a mainstream advertising campaign that appealed to both a male and female gaze. A man's body could be sexualized outside the pages of gay erotic imagery, and women could find pleasure in looking. The social and physical power of masculinity was no longer expressed solely through the world of work, but through a semi-nude body clad in designer underwear.

While male underwear was playing with the idea of the erotic as well as the practical, women's underwear began to make reference to athletics, reflecting an increasing interest and participation in exercise and the world of physical culture. From the early twentieth century, as cultural attitudes toward women and sport have changed and an athletic rather than reproductive function has been acknowledged, manufacturers have responded with more practical underwear. One important development was Dupont's invention of nylon in 1938, which helped in the creation of ranges of easy-care, drip-dry underwear. Lycra followed made in 1950, a new material of a knit of two yarns: a synthetic polyester or polyamide, and elastic fiber or spandex.

Underwear that made direct reference to athletics was to reach a height in the 1980s when aerobic exercise and the newly toned and muscled body that ensued became the cultural ideal for women. The runner Hinda Miller invented the sports bra, which became a classic of women's underwear design, made of stretch fabric with no fasteners so as to be pulled over the head with ease—a direct response to the needs of sportswomen that

has entered mainstream fashion. The sports bra has become a signifier of a healthy lifestyle rather than a garment simply worn by women athletes. By the early twenty-first century many items of underwear had body control as their primary function. The taboos around the intake of food and keeping the inner workings of the body pure through organic food and practices such as colonic irrigation have influenced underwear design, which evokes a “naturalness” and a “simplicity” to match the twenty-first century obsession with body engineering. Ironically, this supposedly “natural” look runs concurrently with an emphasis on the artificial in the guise of the Wonderbra and other forms of more erotic and body shaping underwear.

Underwear is no longer unmentionable, and the world’s leading fashion designers and celebrities are prepared to lend their names to or launch ranges of directional underwear design—from Australian model Elle Macpherson and pop star Kylie Minogue to brands such as Tommy Hilfiger and Chanel. Designer label underwear carries such cachet for the young consumer that it is pulled up the body so as to be displayed openly over the waistbands of jeans, following a look originally associated with the protagonists of hip-hop culture from the South Bronx of New York in the 1980s.

*See also* **Corset; Jockey Shorts; Lingerie; Slip.**

#### BIBLIOGRAPHY

- Carter, Alison. *Underwear: The Fashion History*. London: B. T. Batsford Ltd., 1992.
- Flügel, J. C. *The Psychology of Clothes*. London: Hogarth Press, 1930.
- Polhemus, Ted. *Bodystyles*. London: Lennard Publishing, 1988.

*Caroline Cox*

**UNIFORMS, DIPLOMATIC** Diplomatic uniforms are civilian uniforms worn by ambassadorial and consular officers at public occasions. These uniforms appeared around 1800 when European countries began to reform their administrations and assign uniforms to many of their public officials. Previously, diplomats, who usually belonged to the highest nobility, had worn their own splendid clothes at solemn occasions. Only the colors and badges of their livery servants’ clothing indicated the ambassador’s own court and the court of the ruler he represented (*Nach Rang und Stand*, pp. 85–93, 252–255).

#### History

In the second half of the eighteenth century, several European countries began to consider uniforms for their envoys to foreign countries. As early as 1768, France ordered that her consuls in charge of trade and shipping traffic in the Near East wear uniforms of the navy’s commissioners and under-commissioners. By 1781, the French con-

suls received their own uniforms of blue cloth with red lining, red waistcoat, and breeches, decorated with buttons featuring the king’s coat of arms and trimmed with gold braids denoting respective rank. One of the reasons for the introduction of diplomatic uniforms can be found in a letter sent by Netherlands consuls in Spain to their home country in 1776. They asked for uniforms in order to save money and claimed that uniforms would relieve them from buying expensive fashionable clothes needed for representing their country (Kramers, p. 23).

For patriotic reasons and in order to promote abroad the ideas of a national republican state, the First French Republic required that its representatives at foreign courts dress in the uniform of the French *Garde Nationale*. However, these early regulations were obviously not yet strictly followed, as an official portrait of Guillemardet, the French ambassador in Spain at that time, shows him wearing his private clothes together with a tricolor sash wound around his waist (Delpierre, p. 31).

Diplomatic uniforms became part of general administrative reforms issued by most European countries around 1800 as a response to the French Revolution and the Napoleonic wars. When in the past the ambassador’s impressive appearance depended on his personality and his own individual means, now uniforms made the person stand back behind the office he represented (Lüttenberg, p. 86–87). In several countries, diplomatic uniforms were among the first civilian uniforms to be issued because they represented the new reformed state to the outside world. When Count Maximilian von Montgelas, minister and head of the new reforms in Bavaria, ordered uniforms for the Bavarian state officers in 1799, he began his campaign with the office of foreign affairs. His regulations, published in 1807, were basically kept until as late as 1918. In fact, in most European countries, the design of the diplomatic uniforms changed very little in contrast to other civilian uniforms.

#### Design

The design of the diplomatic uniforms preserved the court fashion of the early nineteenth century, which was marked by richly embroidered tailcoats with standing collar, breeches or pantaloons depending on the formal event, and completed by a sword and a two-cornered plumed hat. With their lavish gold embroidery, the diplomatic uniforms were always among the richest of civil uniforms and resembled those of distinguished court officials. This was considered appropriate because members of the diplomatic corps usually belonged to the highest court circles and represented their country at the most official events at court. While most Bavarian state employees were clad in blue uniforms, Bavarian diplomats dressed in red ones similar to the uniforms worn by high officials of the Bavarian royal court. In most countries, diplomats had to acquire at least two uniforms: a richly embroidered full dress uniform for formal events and a simpler uniform for everyday use. English and



Bavarian diplomats needed three kinds of uniforms: full dress, levée dress, and frock dress.

While military uniforms signal rank mainly by stars and badges, civilian uniforms distinguish rank by the amount and quality of the embroidery. By 1847, the Lord Chamberlain's office divided the British diplomatic corps into five ranks and laid down rules for their respective uniforms precisely specifying the amount and width of the gold embroidery allowed for each rank. Ambassadors, who belonged to the first class, enjoyed the privilege of wearing the richest full dress uniform at grand state occasions. Sparkling gold embroidery of oak and palm leaves covered large areas of the tailcoat's chest, collar, cuffs, pocket flaps, and back skirts, as well as the seams. Gilt buttons showing the royal arms buttoned down the chest. White breeches, a sword, sword knot and belt, gloves, and a two-cornered hat with white ostrich feathers completed the full dress uniform. For less grand occasions, the English ambassadors donned the so-called levée dress uniform. Being less opulent its gold embroidery was restricted to the collar, cuffs, pocket flaps, and between the buttons on the rear waist. Long trousers belonged to the levée dress because they were considered less formal than short breeches. The embroidery on the full dress and levée dress uniform diminished in amount and width as the rank descended. (At informal dinners and evening parties, all members of the English diplomatic corps wore plain black frockcoat). Signaling a lower status within the foreign services, the uniforms of the English consular staff were decorated with embroidery of silver instead of gold (Tendrell, 35–42).

Most European diplomatic uniforms were quite similar in shape but varied in color, design of embroidery, and of course in the design of the buttons showing the coat of arms or initials of the ambassador's ruler. Austrian diplomats dressed in dark green tail coats with cuffs and collars of black velvet covered with gold oak leaf embroidery. After 1817, Prussian diplomats wore dark blue tail coats with cuffs and a standing collar of black velvet, decorated with gold embroidery showing neoclassical oak leaf scrolls. Whereas during the course of the nineteenth century most uniforms of governmental officials became modernized along with the military uniforms, the ornate diplomatic uniforms tended to keep their traditional shape. In 1888, when the German government revived the *altbrandenburgische waffenrock* as the full state uniform to be used by most governmental officers of upper rank, the diplomats were at first excluded. Only later, after having launched several requests, did the German diplomats receive permission to wear the richly embroidered long coat, which revived elements of uniforms worn by Prussian military officers during the eighteenth century (Lüttenberg, p. 90).

#### Later and Non-European Developments

Although the majority of the European countries gave up uniforms for most of their governmental officers at the



**Diplomats discuss the Treaty of Ghent, 1814.** Early nineteenth-century, European diplomatic uniform boasted tailcoats with standing collar, breeches, and gold embroidery. A sword and two-cornered plumed hat, not pictured, completed the ensemble. THE GRANGER COLLECTION, NEW YORK. REPRODUCED BY PERMISSION.

end of World War I, several countries decided to keep diplomatic uniforms. Germany, for example, had already abandoned its richly embroidered diplomatic uniforms during the Weimar Republic, although the Nazis' fondness of impressive uniforms brought back the diplomatic uniform for a short while. The stage designer Benno von Arent recreated a new diplomatic uniform with the help of Mrs. von Ribbentrop, wife of the German foreign minister. Its full dress uniform consisted of a dark blue tailcoat with silver oak leaf embroidery covering the coat's modern lapels. A silver sash, silver aiguillette, and a small dagger completed the startling uniform. Even by the twenty-first century, some European ambassadors still appeared in full dress uniforms at special occasions. A photo taken of the New Year's reception at the Vatican in 2001 shows from left to right the ambassadors of Monaco, the Netherlands, Thailand, Great Britain, Spain, France, and Belgium, all clad in splendid diplomatic uniforms.

The embroidered full dress uniform of European diplomats impressed several non-European courts. Formal portrait photos taken during the nineteenth century depict Indonesian princes wearing jackets richly embroidered with gold thread in the style of Western diplomatic state uniforms together with multicolored native sarongs and pajamas. A most striking adaptation of Western state uniforms took place in Japan in 1872, when two centuries of isolation had come to an end and the Japanese emperor Meiji decided that all members of his military, court, and government (including the diplomatic corps), abandon traditional Japanese dress and adopt European uniforms.

Quite in contrast to monarchic countries, the republican United States renounced civil uniforms for its diplomats, and their use was even prohibited by Congress. Of Civil War veterans only those of the Northern states were allowed to wear their military uniforms. Consequently, during the nineteenth century, American diplomats frequently ran into trouble when trying to attend formal events at European courts, which would only admit men in uniform. Thus, Theodore Roosevelt attracted considerable attention when he attended the funeral of the English king Edward VII in 1910 and was the only foreign representative who did not appear in uniform.

See also **Fashion and Identity; Uniforms, Military.**

#### BIBLIOGRAPHY

- Delpierre, Madeleine. "Fonctions diplomatiques." *Uniformes civils français cérémonial circonstances 1750–1980*. Paris: Musée de la mode et du costume, 1982. pp. 31–32.
- Hackspiel-Mikosch, Elisabeth, ed. *Nach Rang und Stand: Deutsche Ziviluniformen im 19. Jahrhundert*. Deutsches Textilmuseum: Krefeld, 2002.
- Kramers, C. J. M. "Iets over de ambtscostuums van de Buitenlandse Dienst." *BZ, Maanblaad vor de medewerkers van het Ministerie van Buitenlandse Zaken* 50 no. 6 (1988): 23–27.
- Kugler, Georg J., and Monica Kurzle Runtscheiner. *Des Kaisers teure Kleider, Festroben und Ornate, Hofuniformen und Livreen vom frühen 18. Jahrhundert bis 1918*. Vienna 2000: 135. Catalog nos. 67–72.
- Lüttenberg, Thomas. "Der gestickte Rock—Deutsche Diplomatenuniformen im 19. Jahrhundert." *Nach Rang und Stand—Deutsche Ziviluniformen im 19. Jahrhundert*. Edited by Elisabeth Hackspiel-Mikosch. Deutsches Textilmuseum Krefeld 2002. pp. 85–93.
- Schmidl, Erwin A. "Tropen- und Sommeruniformen der k.u.k. Konsular und diplomatischen Beamten 1913–1918." *Mitteilungen des Österreichischen Staatsarchivs* 40 (1988): 302–319.
- Trendell, Herbert A. P. *Dress Worn at his Majesty's Court. Issued with the authority of the Lord Chamberlain*. London, 1908. pp. 35–42.

*Elisabeth Hackspiel-Mikosch*

**UNIFORMS, MILITARY** Distinctive attire for pursuing the business of battle has been part of armed conflict everywhere in the world since humanity invented war. The very carrying of arms, both offensive and defensive (spears, clubs, shields, helmets, etc.), gives the warrior a different appearance from someone engaged in more pacific tasks. However, the idea of a military uniform, clothing all members of a unit in similar dress, is a relatively late development in the long history of human conflict.

In various parts of the world, minor or major potentates and warlords used part of their wealth to clothe

a corps of guards in uniform dress in the same manner that other palace servants might wear some sort of personal livery. This sort of early uniform survives in the ceremonial dress of the contemporary Papal Guards in Rome (according to legend, designed by Michelangelo) and London's Yeomen of the Guard, whose uniform is similar to that worn in the courts of the Tudors. True military uniforms, however, only came into use with social and political developments in Europe that have come to be known as the "military revolution."

The military revolution came about in the late sixteenth and early seventeenth centuries, as musketry fire from mass formations became decisive on Europe's battlefields. While the individual musket was an ineffective weapon, when used by well-drilled and well-disciplined troops, the musket allowed infantry so armed to dominate any battle. This change in weaponry led to the crystallization of military organization into professional armies consisting of relatively highly trained rank and file soldiers arranged in permanent organizations. At first these units were raised by individuals who sold their services to the highest bidder. The unit commander then provided clothing for his troops; the interests of economy as well as building *esprit de corps* led to uniformity of clothing within these units.

An important aspect of combat is the ability to distinguish friend from foe. Prior to the domination of the battlefield by gunpowder this could be accomplished through the use of standards or flags (such as the eagle of the Roman Legion) or temporary identification devices (scarves or armbands) allowing one side to recognize its allies. However, the possibility for fatal errors in unit identification was great on seventeenth- and early eighteenth-century battlefields enshrouded in smoke from the volleys fired from black-powder weapons. Even flags were of little help as these were often emblazoned with the badge of the unit's commander rather than a national symbol.

This led to a spread of uniformity of dress beyond the battalion level to that of most of the military forces of a kingdom or state. As permanent military establishments were developed in Europe, the practicality of uniform regulation for all troops in the service of the state became recognized. By the mid-eighteenth century colors of clothing had become associated with national armies. Britain largely clothed its army in red, France in pale gray or white, Prussia in dark blue, Bavaria in sky blue, Austria in white, Russia in dark green, etc. There were exceptions; foreign regiments in the service of French monarchs, for example, often wore red or blue. Following the events of 1789 the new French republic changed the color of the uniform of the French infantry to blue.

Sometimes a uniform color had significance that crossed national boundaries. Both Britain and France dressed their artillery in blue. German and British rifle regiments were clothed in a very dark green. Naval uni-



**The Texas A&M Drill Team in full dress uniform.** Though military uniforms in the twentieth century adopted styles more functional for combat, some ceremonial uniforms continued to display elements of military pageantry. © PHILIP GOULD/CORBIS. REPRODUCED BY PERMISSION.

forms throughout the globe have been of navy blue (white in the summer) and more recently the world's air forces have worn a dress uniform of light blue.

### Principles Underlying Military Dress

James Laver has seen three competing principles that determine the form of military uniforms. He named these the hierarchical principle, the seduction principle, and the utility principle. The hierarchical principle manifests itself in differentiating ranks within a military organization and differentiating elite from ordinary soldiers. Hence, since 1831, the regiments of foot guards in the British army have worn the bearskin headdress that distinguishes them from line-infantry regiments. This also represents the seduction principle, since the headdress increases the height of its wearer, hence making him more masculine and attractive. Laver argues that both the hierarchical principle and the seduction principle manifest themselves in times of peace; however, both produce a form of dress often impractical in the face of the rigors of campaign. In times of war, badges of rank may be dispensed with because they draw enemy fire, illustrating the victory of the utility principle over the hierarchal

principle. Similarly, the seduction principle yields to utility as tight-fitting, "smart" uniforms of the parade ground are replaced by looser dress allowing the ease of movement necessary in combat.

While the hierarchical principle dictates that elite units differentiate their dress from ordinary military units, there is also the fact that it seems to be nearly universal that others if given the opportunity will appropriate the symbols of elite status. The jump boots of American paratroops in World War II were once a proud symbol of their elite status, but later in the war they came to be devalued as a status symbol as other soldiers, even those in noncombatant roles, acquired them.

It is also true that an army of one nation will adopt the dress of the army of that state which is perceived to be a superior military power. Throughout history one country or another has dominated military style, with others copying their uniforms. French military style dominated the uniforms of much of the world's military until its defeat in the Franco-Prussian war; then armies throughout the world replaced their French kepis with German spiked helmets. Also, units aspiring to similar elite status will ape dress of other elites. In many of the



world's armies the green beret has come to be associated with elite commando formations, the red beret with airborne troops, and the black beret with armored troops. In World War II, the British commander Bernard Montgomery and the men of the Royal Tank Corps wore black berets, as did the Germans in the Panzers they fought in the North African desert. In earlier centuries light cavalry worldwide adopted the heavily laced jacket of the Hungarian hussar or the square-shaped *czapka* headdress of the Polish lancer.

### The Evolution of Military Uniform

In cut and general form, military uniforms reflect the style of civilian fashion of their time, although distinctive elements, such as epaulets and headgear, are added that clearly mark the wearer as a soldier. After body armor largely fell into disuse in the mid-seventeenth century, the soldier dressed like his civilian cousin, although the colors of his clothing would reflect his unit and increasingly the state or monarch he served. The necessity to carry arms with belts capable of holding ammunition pouches, bayonets, swords and the like did give the soldier a distinctive appearance.

Even at this early point in the evolution of military uniforms a purely military form of headdress, the grenadier cap, came into being. During the late seventeenth century, the grenade was a significant factor in infantry tactics. It was an iron sphere filled with gunpowder that was ignited by a fuse. Specialist troops were trained to light these fuses from a hand-held match and then throw the grenades into the ranks of the enemy. Since two hands were required for this, grenadiers had to sling their muskets on their backs, an operation difficult to accomplish when wearing the broad-brimmed hats of the era. Thus grenadiers were given a sort of stocking cap. Some military tailor concluded that these grenadiers, already selected for their size and strength, would look even more impressive if the cap were stiffened to increase the apparent height of its wearer (Laver's seduction principle). The grenadier cap became a symbol of an elite soldier (Laver's hierarchical principle). Since elite troops were useful for assaulting or defending key positions on a battlefield, European armies continued to designate units as "grenadiers," and these wore grenadier caps long after grenades had become obsolete (hand grenades were reintroduced in warfare in the trenches of World War I). The grenadier cap was sometimes given a metal front (such as that worn by the Russian Life Guard Pavlovski Regiment in full dress until 1914) or made of fur. The fur headdress worn by the Brigade of Guards at Buckingham Palace in London is in fact a grenadier cap.

The horsed soldier was sometimes distinguished from mounted civilians by wearing the cuirass. This body armor continued to be utilized by heavy cavalry long after the infantry had abandoned it. The civilian hat was worn for a long period, despite its proclivity to be blown from the head when engaged in a charge. This tendency

eventually led to the cocked hat being replaced by helmets of various forms in the late eighteenth century. The crest on these helmets served both the seduction principle and the utility principle, for in addition to making the horseman more imposing, it provided some additional protection from sword cuts.

It was the recruiting of light cavalry from the eastern frontiers of Europe that provided a novel and exotic appearance for a large portion of the cavalry in eighteenth- and nineteenth-century European armies. Austria first recruited Hungarian horsemen to serve as light horse in its military establishment. The dress of these Hungarian hussars had a great influence on military style, both for mounted troops and soldiers. Many armies copied the appearance of the Hungarian jacket fastened by many rows of cords and toggles across the chest. A second, fur-lined jacket (the *pelisse*) slung over the left shoulder was also widely adopted in the dress of light cavalry, as was the *sabretache*, a leather pouch or envelope that was suspended from the sword belt.

It is Hungarian headgear that probably had the greatest impact on the appearance of the military. These horsemen wore either a stocking cap edged in fur or a cylindrical felt cap. Through time the fur on the stocking cap was expanded, making the fur cylinder with a bag falling to one side from the top, a form of headdress known as the *busby*. The cylindrical felt cap was the inspiration for the *shako*. The *shako* was widely adopted in all branches of the military during the Napoleonic Wars. Britain dressed its infantry in *shakos* in 1800; it was not until 1806 that the line infantry of Napoleonic France adopted this headdress. The *shako* continued as the most common form of military headgear until the defeat of France by Prussia in 1870 and continues to be worn by some units (as, for example, in the full dress of the Corps of Cadets of the U.S. Military Academy).

Just as Hungary provided the pattern for the dress of hussars in armies around the globe, Poland provided the model for the dress of lancers, particularly after Poles played a prominent role in the multiethnic armies of Napoleon. The square-topped *czapka* and plastron-fronted jacket or tunic with piping along its seams was worn by substantial segments of cavalry in Europe and even had an impact on the uniforms of colonial India.

In considering the pressure for elaboration of military uniform and the counter pressure for utility, one can contrast the European experience of the Napoleonic Wars and the long era of peace that followed that conflict. While in theory the armies that fought in the Napoleonic Wars had colorful and elaborate uniforms, in practice they presented a much more drab appearance. Uniforms faded in the sun or wore out on long campaigns and were replaced by clothing obtained locally. The rigors of winter campaigning forced troops to march in gray or brown overcoats rather than full-dress coatees. Plumes would be stowed in knapsacks, while *shakos* or bearskin



**Early twentieth century West Point military academy cadets.** The shako, a hat worn by the cadets shown here, held the allure of adding apparent height to the wearer. ANNE S.K. BROWN MILITARY COLLECTION, BROWN UNIVERSITY LIBRARY. REPRODUCED BY PERMISSION.

bonnets would be protected from the weather by oilskin covers. Loose trousers replaced the tight breeches and long buttoned spatterdashes or gaiters of the parade ground. With the coming of the long period of peace following Napoleon's defeat, the appearance on the parade

ground moved to the forefront and uniforms reached a degree of fantastic elaboration not seen before or since. The realities of war returned in the late nineteenth and early twentieth centuries to banish such sartorial splendor from military life.

Reflecting changes in civilian fashion, by the mid-nineteenth century the tight-fitting waist-length coatee, widely worn for nearly fifty years, was replaced in the world's military by the tunic or frock coat with skirts that at least partially covered the thigh. Russia and Prussia also adopted leather helmets with brass spikes, while for the most part the rest of the world continued to wear the shako or kepi. At this same time there were developments in firearms technology that led to a revolution in military uniforms.

For almost three centuries the smooth-bore musket had dominated the battlefield. The effective range of this weapon was so short (one hundred yards or less) that troops were drilled not to fire until they could see the whites of the eyes of their enemy. Hence, the color of a uniform was unimportant as long as one could be recognized by one's allies and not be taken for the enemy. While there was some use in battle of firearms with rifled barrels that were effective at far greater distances, these early rifles were cumbersome to load. The invention shortly before the American Civil War of a rifle, which could be loaded as rapidly as the old smooth-bore musket, was soon followed by the invention of a breech-loading rifle. A further innovation was the magazine rifle allowing an infantryman to fire several shots after a single act of loading his weapon. Smokeless powder eliminated the huge clouds of acrid smoke that obscured vision on the black-powder battlefield. All of these factors led to the adoption of uniforms whose purpose was to inhibit the recognition of troops at the great distances at which they were now vulnerable to rifle fire.

Khaki was first used in India, originally in the Corps of Guides raised by Lieutenant Harry B. Lumsden in 1846. A decade later, during the Indian Mutiny, a number of British regiments dyed their white summer uniforms khaki to be less visible on the battlefield. While Britain experimented with other drab colors, notably gray, khaki was worn in India, becoming official dress for that station in 1885 and for all foreign stations in 1896. In 1902 Britain adopted a khaki service dress. Other nations followed Britain's example; the first three to adopt a khaki service dress were the United States, Japan, and Imperial Russia. Both France and Germany used khaki for their colonial troops, but Germany in 1910 chose a light gray for its regular army and France, while it began the Great War still in dark blue uniforms, switched to horizon blue early in 1915.

The trench warfare of 1914 to 1918 led to the universal adoption of steel helmets. The threat of gas attacks meant gas masks had to be easily accessible. Trenches, barbed wire, and the machine gun reduced the cavalry to no role at all. Increasing mechanization meant the auto mechanic replaced the farrier in keeping the supply lines functioning, and at least one critic of modern trends in uniforms has lamented that the dress of the soldier now mimics that of an employee of a service station. The war

changed the view of the proper soldiers from that of impressively and colorfully dressed units executing precision drill on the parade ground to massive armies engaged in savage warfare under the appalling conditions of the modern battlefield. The pomp and splendor of military pageantry and glory of full dress observable before the war (as late as 1913 the German army was executing maneuvers in a version of full dress) was gone forever.

Wars subsequent to the watershed years of 1914 to 1918 have seen the combat uniform increasingly, and with greater sophistication, being designed to prevent the soldier from being seen rather than allowing an imposing appearance to frighten or cow the enemy. Khaki and olive drab have been replaced by "disruptive pattern" clothing to conceal even more effectively the fighting man or woman. Uniforms have come to be designed even to conceal the soldier from the night-vision equipment finding increasing use on battlefields. The small flashes of color, the division patches that identified the soldier's unit in World War II, have been reduced in the American army to black on olive drab. The increased emphasis on concealment has exacted a price, however, as "friendly fire" has at times proved as hazardous to troops engaged in military operations as the fire from a dispirited enemy overwhelmed by a long period of bombardment from aircraft and missiles.

There has also been an emphasis on attempting to protect the soldier in combat. Modern technology has produced lightweight body armor, "flak jackets," to protect the torso. Some nations have suits, yet untried in a combat situation, to enable the soldier to fight on a battlefield contaminated by nuclear or biochemical weapons.

### Modern Ceremonial Dress

Ceremony still plays a role in the relation of the military to the state, and dress appropriate for this ceremonial role is still significant in most military establishments. Although in a few cases, as with the British Brigade of Guards and the U.S. Marine Corps, uniforms virtually unchanged from the pre-1914 full dress are utilized, most of the world's military carries out ceremonial duties in much more drab clothing. Although economy is often cited as the reason for this abandonment of the full-dress uniforms, major portions of most armies utilize an order of dress for parade that could easily reflect earlier full-dress uniforms. It is modern fashion that dictates that the modern soldier parade in khaki or a similar shade. Yet in most military organizations there remains pressure to present a "smart" appearance on parade. In some cases, contemporary combat dress is utilized with the addition of ceremonial elements of uniform. The French Foreign Legion parades in camouflage combat attire with the addition of spotless (and plastic) white belts and the traditional green and red epaulets and the white kepi that date to the nineteenth century. There is still more than simple utility in the creation of the dress of the soldier.



See also **Armor; Camouflage Cloth.**

#### BIBLIOGRAPHY

- Abler, Thomas S. *Hinterland Warriors and Military Dress: European Empires and Exotic Uniforms*. Oxford: Berg, 1999.
- Carman, William Young. *A Dictionary of Military Uniform*. London: B.T. Batsford, Ltd., 1977.
- Joseph, Nathan. *Uniforms and Nonuniforms: Communication through Clothing*. New York: Greenwood, 1986.
- Knötel, Richard, Herbert Knötel, Jr., and Herbert Sieg. *Uniforms of the World: A Compendium of Army, Navy, and Air Force Uniforms, 1700–1937*. Translated by Ronald G. Ball. New York: Scribners, 1980. Originally published as *Handbuch der Uniformkunde*. Hamburg: H. G. Schulz, 1937.
- Laver, James. "Fashion and Class Distinction." *Pilot Papers* 1 (1945): 63–74.
- . *British Military Uniforms*. London: Penguin, 1948.
- Lawson, Cecil C. P. *A History of the Uniforms of the British Army*. 5 vols. London: Kaye and Ward, 1940–1967.
- Mollo, John. *Military Fashion: A Comparative History of the Uniforms of the Great Armies from the 17th Century to the First World War*. New York: G. P. Putnam's Sons, 1972.
- Parker, Geoffrey. *The Military Revolution: Military Innovation and the Rise of the West, 1500–1800*. Cambridge and New York: Cambridge University Press, 1996.
- Windrow, Martin, and Gerry Embleton. *Military Dress of North America, 1665–1970*. London: Ian Allan, 1973.

Thomas S. Abler

**UNIFORMS, OCCUPATIONAL** Occupational uniforms are nonmilitary civilian uniforms worn by members of certain professional groups during work or at official occasions. Specified and usually handed out by the employer, the uniform is designed in certain colors and carries signs and badges which signal the employee's function and rank within a professional organization.

#### Court Liveries

The first examples of occupational uniforms are liveries (from the French word *livrer*, meaning to deliver), which were uniform garments handed out to servants at European courts during the early modern period. Uniform in color, form, and decorations, liveries represented the household for which a servant was working. The coat of arms or initials of his master appeared on the liveries' buttons, trimmings, or badges. Already during earlier periods, princes, such as the Burgundian dukes, had their court members and servants dress in a single color at festive events in order to present a unified court. The livery proper began to spread during the seventeenth century, when the social status of a prince depended more and more on the splendid appearance of his court and his servants. These early liveries corresponded closely to military uniforms, which developed at the same time and which in the beginning were also called livery (in France, *livrée*; in Germany, *liberey* or *montur*). The colors of the



**Airline pilot in uniform.** In the twenty-first century, commercial pilot uniforms were designed in accordance with the desired marketing image of the airline. © ROYALTY-FREE/CORBIS. REPRODUCED BY PERMISSION.

military uniforms were usually identical to the liveries belonging to the household of the regiment's chief who, prior to the establishment of national armies, often owned the regiment.

Just like military uniforms during the seventeenth and eighteenth centuries, most servant liveries were cut according to contemporary fashion. Their striking colors, heightened by lining and trimmings in contrasting hues corresponded to the colors of the noble household to which the servants belonged but were not necessarily identical with its heraldic colors.

Like military uniforms, the liveries also functioned as signs of rank and distinction. Most important, the servant's livery presented the social rank, ambitions, and financial means of the master. For this reason the American economic theorist Thorstein Veblen regarded servant liveries as a prime example for his seminal theory of conspicuous and vicarious consumption. The livery also indicated the servant's rank within a household. For example, the dress of pages, who themselves were members of noble families, were more richly decorated and made of more costly materials than the liveries of other servants. The servant's nearness to the master also determined the preciousness of his outfit. Since footmen accompanied their master very closely during travels, their dress had to be made of particularly fine materials, even though the footmen's small salary reflected a low position at court (Mikosch, p. 295). The livery always signaled the rank of the occasion: the more official the occasion, the richer the livery had to be; therefore, most courts provided simple liveries for everyday use and costly ones for festive events.

During the second half of the nineteenth century, when class distinctions became increasingly complex and



**Depiction of nineteenth-century Austrian postman.** In 1785, Prussian postmaster von Werder was an early proponent of obligatory uniforms for postal workers, arguing that the uniforms would not only distinguish postmen but also save them money. © SCHEUFLER COLLECTION/CORBIS. REPRODUCED BY PERMISSION.

nobility lost more and more of its privileges, servant clothes had to make up for the loss of status. Some late courts, like the one of the prince of Thurn and Taxis, put on a particularly rich display of servants fitted out with numerous liveries. The servants of Thurn and Taxis had to change clothes several times during the course of the day, even as late as the 1980s (Kliegel, p. 107). In order to project the image of a long aristocratic tradition, the design of the servant liveries tended to be antiquated. The tightly fitted *juste au corps*, fashionable during the eighteenth century and decorated with rich gold braids, continued to be employed for formal occasions and tailcoats for less formal events or everyday use.

### Early Professional Uniforms

Besides livery servants, postmen and miners were the earliest professional groups clad in uniforms. In the beginning, only certain signs, badges, or accessories symbolized their profession. During the sixteenth century,

messengers were not yet dressed in uniforms but in regular traveling coats. They carried a badge on their chest or cap with the coat of arms of the city or noble court they served. Records of the seventeenth century already identify the horn as the sign of postal servants. The first time postal servants and officers were dressed in complete uniform clothes was early in the eighteenth century during celebrations at the Prussian (1703) and Saxon courts (1719). When the Saxon Elector Frederick Augustus and Polish King Augustus I, called Augustus the Strong, married his son Frederick Augustus to the imperial daughter Maria Josepha in 1719, he organized lavish wedding celebrations in Dresden and ordered his postal service and Saxon miners to take part in large numbers. For this occasion uniforms were designed that distinguished between the ranks and functions within a profession for the first time (Mikosch, pp. 315–332). Augustus, who was the head of the postal services and of the mining industries in Saxony, used the uniforms in order to present the image of a modern prosperous country. Consequently, these early occupational uniforms were actually splendid state uniforms mainly used for parading during court festivals. Lacking the necessary funds and the administrative structure, neither the Prussian nor the Saxon ruler succeeded in establishing regular occupational uniforms for their entire country at this time.

### Civil Uniforms for State Employees

One of the first serious campaigns that tried to introduce an obligatory everyday uniform for members of one profession can be traced back to Germany in 1785 when the Prussian king Frederick II followed the suggestions of his general postmaster von Werder and decreed that all postal servants had to wear uniforms. He ordered state uniforms and uniforms for daily use. They consisted basically of blue coats with orange-colored collars and cuffs. Accessories, such as epaulets, aiguillettes, hat decorations, and swords distinguished between the ranks of the postmaster, postal secretary, postal attendants, and postilions. Von Werder's arguments anticipate the coming years when civil uniforms for state employees became more prevalent. He suggested that postal uniforms would help the servants save money, prevent them from wasting money for extravagant outfits, and ensure they dressed in respectable clothes. At the same time the uniforms would make the postal servants more easily recognizable to the general public.

Around 1800, many European countries introduced occupational uniforms for state employees as an important part of extensive administrative reforms that most countries issued as a response to the French Revolution and Napoleonic wars. The new reforms broke down the privileges of the aristocracy and the church, and prepared the ground for the development of a modern bourgeois society. The governmental officers' uniforms were intended to serve as symbols for the new ideal of a nation state run by an efficient and just administration. Inspired

by those of the military, the uniforms' shape, colors, and decorations signified the function and rank of the officer. The uniforms were intended to work on two levels. From within, they enhanced the new bureaucratic structure and lent new confidence and pride to the state employees. From without, the uniforms were intended to evoke acceptance of the new state and its regulations as well as elicit new respect for its employees as the executors and representatives of the new state. The uniforms' shape underlined this message. Forcing an upright position the uniforms' particularly tight cut enhanced the proud and masculine impression of the man in uniform. Gradually most employees of governmental departments were clad in uniforms, no matter if they worked in public or not. This included, among others, the police services, fire departments, postal services, state-run mining and metalworking industries, forestry and transportation departments, as well as the departments of finance, interior, justice, and foreign affairs.

The general form of the occupational uniforms for state employees varied little during the nineteenth century and followed the form of military uniforms, beginning with tailcoats early in the century and adding the more practical, buttoned-down military tunic after the mid-nineteenth century. Most departments demanded state uniforms embroidered with gold and silver thread to be worn by officers at special occasions and simpler ones for everyday use. Smaller states, such as the dukedom of Brunswick, wanted to enhance their political importance by affording a luxurious array of uniforms in different colors and embroidery designs for each department. The large states of Prussia and Bavaria emphasized unity and efficiency by restricting their uniforms to one color. Prussia chose a dark blue ("Prussian blue"), and Bavaria ordered uniforms in a medium blue. Certain trimmings and signs identified different departments and ranks. The Prussian postal services wore their blue uniforms with orange-colored collars, cuffs, and pocket flaps. Bavarian uniforms had small symbols embroidered in silver thread on the tail: small horns stood for the postal service and winged wheels for the department of transportation. Each country had its own buttons showing either the coat of arms of the state or the initials of the ruler. The richness and width of embroidery on the chest, collar, cuff, and pocket flaps were meticulously prescribed and varied according to the rank of the officer within the administrative hierarchy (Hackspiel-Mikosch, pp. 221–287).

If the civil uniform symbolized the new administrative structures of modern states early in the nineteenth century, by the end of the century the civil uniform was regarded as a sign of stultifying and overexpanding bureaucracies supporting conservative governments, which, as in the case of Germany, became increasingly militaristic. At the end of World War I, when the German empire and its local monarchies were abolished, most civil uniforms for state employees disappeared. The Weimar Republic regarded the civil uniforms as a symbol of an



**Royal English footmen in traditional uniform.** Due to their proximity to their masters during travel, footmen traditionally wore uniforms of quality and decoration well above their court standing. © TIM GRAHAM/CORBIS. REPRODUCED BY PERMISSION.

outdated authoritarian state. Although, a few decades later, the German Nazi regime indulged in impressive uniforms, it did not revive civil uniforms for state employees. Instead, mass organizations such as the labor service were established. These organizations were structured like military institutions, and employees dressed in uniforms closely reflecting military hierarchies.

After the two world wars, only law-enforcement sections of the government (police, immigration, or prison wards) as well as certain public services (postal services, railways, fire fighters, or foresters) continued to wear uniforms. In Germany, the devastating experience of two world wars that had been supported by widespread militarism triggered a pacifistic countermovement during the 1960s and 1970s that regarded state authority and its uniformed representatives with strong skepticism. Responding to a signature campaign initiated by a young policeman who wanted less military-like and identical modern uniforms for all of Germany, in 1973 the German fashion designer Heinz Oestergaard created a new



green-beige police uniform, which, with certain changes, is still worn today. The modern design and friendly colors of Oestergaard's more casual-looking uniforms were intended to communicate a modern and democratic image of Germany.

Some traditional civil uniforms continue to be worn today. Servants clad in sparkling livery still attend at European courts during important public occasions. Some European diplomats go on dressing in traditional richly embroidered state uniforms at formal occasions, such as New Year's receptions given by a head of state. Members of the Institut de France, the most elevated academic institution in France, still wear uniforms that were originally introduced in 1801 and are richly embroidered with olive branches in shades of green silk on black cloth. The academician's uniform is completed with a plumed two-cornered hat and a sword. Each generation tends to adapt the uniform's basic tailcoat to contemporary fashion. In 1981 Yves Saint-Laurent designed a modern version for Marguerite Yourcenar, who became a member that year.

### Modern Occupational Uniforms

Since the second half of the twentieth century, the character of occupational uniforms has changed significantly. Reflecting the democratization of Western society, the uniforms' military elements, which symbolized the rank and function within a hierarchical organization, have stepped more and more into the background. Instead, professional uniforms have become part of modern concepts of corporate identity and corporate culture. Called corporate wear or corporate fashion, uniform dress at work is designed to communicate the philosophy of an organization or company and thereby is an increasingly important tool of marketing strategies. Investigations show that corporate fashion can significantly raise the image of a company and thereby elevate its stock-market value. Within a company, uniform dress, which is comfortable, fashionable, and clean, has been shown to improve working performance of employees by increasing their motivation and their identification with their company and fellow workers. A good-looking professional uniform attracts new customers and produces the image of trustworthiness and economic achievement. In his study of the ubiquitous civilian uniform in Japan, Brian McVeigh has revealed how much uniforms discipline the mind and body of Japanese office workers and, at the same time, express a particular economic nationalism in Japan.

The style of corporate uniforms changes according to the message a company wants to convey. The new uniforms for the German airline Lufthansa, introduced in January 2002, for example, are rather conservative. According to the company's public release, Lufthansa wanted their new uniform to convey the values of traditionalism, respectability, service competence, and timeless elegance. Uniforms of national airlines vary in style and are often understood as the business card of an en-

tire nation. In contrast to Lufthansa, the German Railway decided on more innovative and fashionable uniforms intended to create the impression of a modern inventive company. When the German postal services introduced new uniforms in 2002, they kept the traditional blue and yellow colors but chose a more casual design, emphasizing comfort, function, and a young sportive style. The uniform of the American postal services is less concerned with fashionable change. The uniforms of their letter carriers are designed to adjust to the different extreme climates of the United States and to be instantly recognizable by their particular colors. Fast food companies, such as McDonald's, which cater mainly to young people, frequently dress their employees in cheerful colorful and casual-looking uniforms that correspond to the tastes and lifestyles of children and teenagers.

### Production

During the nineteenth century, officers who could afford to had their uniforms made-to-order by tailors who followed the uniforms regulations published by the government. Some prominent uniform suppliers published their own summaries of the regulations and added illustrations and pattern drawings. The widespread need for uniforms during the nineteenth century led to the development of factories that produced ready-to-wear as well as made-to-measure uniforms. Eventually, large department stores offered a whole range of civil uniforms, including very richly embroidered ones.

By the end of the twentieth and the beginning of the twenty-first century, an increasing section of the fashion industry was specializing in the production of corporate wear. According to Public Broadcasting Service (PBS), the National Association of Uniform Manufacturers and Distributors estimates that the American "career apparel" industry is worth at least \$6 billion. International companies as large as McDonald's potentially spend as much as \$60 million a year on their uniform programs (Fast Food Fashion).

Today the industry offers a wide variety of clothes ranging from simple standard items, such as T-shirts and sweaters individualized by embroideries and corporate colors, to complete corporate fashion lines. When a large organization decides to introduce new uniforms it usually follows a long procedure. Well-known designers are hired to work very closely with the executive management in order to develop a unique design that communicates the company's corporate image. Before ordering new uniforms, prudent companies find out their employees' wishes and expectations and have them test sample garments to determine whether the uniforms can fulfill the requirements of practical function, quality, and comfort.

In times of economic instability the importance of corporate fashion grows as the image of a company can determine its failure or success in an increasingly competitive market. As a result, the British marketing company Up &

Down Marketing and Management Consultancy forecasts considerable growth for the corporate wear market, climbing from 168.6 million garments in 2000 to nearly 200 million garments in 2010 in Europe. At the same time, corporate fashion is spreading to more types of companies. Besides airlines, railways, and postal services, which continue a long tradition, a wide variety of service industries make increasing use of corporate wear, such as grocery stores, shopping malls, department stores, entertainment parks, restaurants, hotels, hospitals, and cleaning companies.

The definition of the occupational uniform should not be confused with certain traditional professional garments. The white coats of doctors, and the caps or berets and long gowns of professors, judges, or priests are typical for their profession in some countries. Although these items of clothing communicate symbolic messages and emphasize the special social status and profession of the person, they do not function as uniforms because their shape usually is not precisely prescribed by the employer, nor do the garments necessarily carry badges indicating function or hierarchical status within a larger organization.

See also **Uniforms, Diplomatic; Uniforms, Military.**

#### BIBLIOGRAPHY

- Antonoff, Roman. "Berufsbekleidung im Firmenstil." In *Kleidung im Beruf*. 2nd ed. Informationskreis "Kleidung im Beruf." Königswinter, 1996.
- Chowdhary, Usha. *Clothing for Special Needs: An Annotated Bibliography*. 3rd ed. Mount Pleasant, Mich.: U. Chowdhary, 2002.
- De Marly, Diana. *Working Dress: A History of Occupational Clothing*. London: B.T. Batsford, Ltd., 1986.
- Delpierre, Madeleine. *Uniformes civils français cérémonial circonstances 1750–1980*. Musée de la mode et du costume. Paris, 1983.
- "Des Kranichs neue Kleider: Neue Uniformen für 25.000 Lufthanseatzen. Die Dienstkleidung, geht auf Strecke." In *Lufthansa Nachricht*. Deutsche Lufthansa AG Konzernkommunikation, Frankfurt, 17 January 2002.
- Expedition der Europäischen Modenzeitung ed. *Lexikon des Kleidermachers*. vol. 1: forestry; no. 1 vol 2: liveries; vol 3: uniforms of the German Imperial and Prussian Royal state- and court officers around 1900; vol. 3: uniforms of the German Imperial postal services and railway, Royal Prussian Police etc. Dresden, 1895–1898, (reprint Osnabrück 1993).
- Fasti della burocrazia: uniformi civili e di corte dei secoli XVIII–XIX. *Genua 1984*.
- Fussell, Paul. *Uniforms: Why We Are What We Wear*. Boston: Houghton Mifflin, 2002.
- Hackspiel-Mikosch, Elisabeth, ed. *Nach Rang und Stand: Deutsche Ziviluniformen in 19. Jahrhundert*. Krefeld: German Textile Museum, 2002. Exhibition catalog.
- Kliegel, Marieluise. *Des Dieners alte Kleider. Livreen und Livreeknöpfe - Ausgewählte Beispiele deutscher Adelsbüfe des 19. Jahrhunderts*. Münster, 1999.
- Lister, Margiot. *Costume of Everyday Life. An Illustrated History of Working Clothes from 900 to 1910*. London: Barrie and Jenkins, 1977.
- McVeigh, Brian. *Wearing Ideology: State, Schooling and Self-Presentation in Japan*. Oxford and New York: Berg, 2000.
- Mikosch, Elisabeth. "Court livery and other professional uniforms made for the wedding celebrations of 1719." In "Court Dress and Ceremony in the Age of the Baroque. The Royal/Imperial Wedding of 1719 in Dresden: A Case Study." Ph.D. diss., New York University, 1999.
- Shepelev, L. E. *Chinovnyi mir Rossii: XVIII – nachalo XXv*. (The Civil Service in Russia, 18th to the beginning of the 20th century) St. Petersburg 1999 (in Russian).
- Sluzbeno odelo u 19. i. 20. veku. (Official dress in Serbia in the 19th and 20th century). ed. By Cedomir Vasic, Belgrade 2001. (Serbo-croatian language with English summary, numerous color illustrations)
- Solomon, Michael. "Standard Issue: Many Organizations Believe Employees in Uniform Are More Obedient, Responsive and Reassuring Than Those in Mufti." *Psychology Today* Dec. 1987 vol. 21, no. 12, p. 30.
- Turnau, Irena. *European Occupational Dress from the Fourteenth to the Eighteenth Century*. Institute of the Archaeology and Ethnology, Polish Academy of Sciences. Warsaw, 1994.
- Williams-Mitchell, Christobal. *Dressed for the Job: The Story of Occupational Costume*. Poole and New York: Distributed by Sterling Pub., Co., 1982.

#### Internet Resources

"European Corporate Wear in the 21st Century" Up & Down Marketing and Management Consultancy, London 2003. Available from <[http://www.upanddown.co.uk/CONS\\_Details.cfm?articleID=72](http://www.upanddown.co.uk/CONS_Details.cfm?articleID=72), 8 August 2003>.

"Fast Food Fashion." PBS: Newshour, 2004. Available from <<http://www.pbs.org/newshour/infocus/fashion/uniforms.html>>.

Elisabeth Hackspiel-Mikosch

**UNIFORMS, SCHOOL** School uniforms have their historical antecedents in very old traditions. If understood broadly, "students" have donned special garments to set themselves apart for religious (monastic and priestly training) and economic purposes (apprentices wearing guild attire) for centuries. However, school uniforms as understood in their modern sense are a particular manifestation of a more general uniformization of populations apparent from about the early nineteenth century. This regulation of appearance is more specifically understood as "standardizing" and "disciplining" workers and citizens to meet the requirements of industrialization, capitalism, and national loyalty. Though historically some schools mandated uniforms for religious reasons or to maintain their "tradition," by and large school uniforms have been ideologically inspired by a notion that bodily control and regulated appearance beget social order, within the school and in society at large.



### PRACTICAL CONSIDERATIONS AND FUNCTIONAL CRITERIA FOR SCHOOL UNIFORMS

Though the debate about the actual merits of student uniforms continues in the United States, advocates of school uniforms believe there are key elements to the successful uniformizing of a student body. These include: determining the style of uniforms should involve teachers, school administrators, parents, and students; uniforms should be affordable and available in all sizes; seasonal options should be available; the wearing of uniforms should be mandatory while allowing for special exemptions; recycling programs are suggested, as are the selling or trading of used uniforms; and uniforms should be introduced in the early grades first so students become accustomed to them as they progress through the higher grades.

School authorities might consider mandating age or grade-specific uniforms. Additionally, school authorities and educational administrators ideally should offer a variety of uniforms that are appropriate to gender and local weather conditions.

As for the materials used, important considerations include: durability (how many years it can be worn); dirt-resistant colors; colors that suit most complexions (for example, many suggest that bright red is discouraged since it does not flatter many people's natural coloring); fits all shapes and figure types; washability (preferably, materials should require little—or even no—ironing or dry cleaning); small two-way patterns for economical use of fabric.

Special climatic conditions should be assessed. For example, in Australia and New Zealand, there are criteria for “sun-safe” school uniforms. Or in other places, winter uniforms must be loose-fitting enough for individuals to layer clothes underneath the uniform.

Other practical considerations include degree of adjustability; comfort (enough so that students are not inhibited from engaging in typical school activities); how available mandated uniforms are at local outlets; if uniforms are within the price range of all students; and choosing an appropriate seller and supplier of uniforms.

Obviously, with so many students, selling school uniforms can be extremely profitable, and any in-depth analysis must explore the agenda of apparel manufacturers in advocating the use of school uniforms. Besides clothes manufacturers, giant retail chains such as JCPenney, Sears, Macy's, Target, Wal-Mart, and Kids “R” Us sell school uniforms.

### Uniformity versus Individuality

School uniforms may be thought of as representing in material-cultural form the point in which the forces of two great upheavals, epitomized by the industrial and French revolutions, converge. However, despite encouraging the uniformizing of students (as well as workers and citizens), these two momentous transformations often work at cross-purposes. The industrial revolution was an economic project that eventually required formal schooling to learn radically new habits for rationalized labor. School uniforms came to symbolize the person as interchangeable and modular. Meanwhile, a more political project, the French Revolution (and other similar revolts of the same period), encouraged self-determinism and individuality, ideals that were often contravened by dress uniformity (in addition to demanding uniformed students—that is, workers-in-training—the industrial revolution immeasurably facilitated the spread of student uniforms through mechanical standardization and mass production). The tension between economic production and political liberation continues to shape debates about school uniforms: Some argue that school uniforms increase social order while others contend they run the danger of violating a person's right of self-expression. To what degree school uniforms actually do the latter, along with threatening a student's autonomy, self-worth, and dignity is, of course, debatable. In any case, contemporary discussions about school uniforms also reveal deeper concerns about student performance, school safety, the maintenance of social order, and the relation between the individual student (citizen-in-training) and the state.

From a more abstract perspective, one way to view the role of uniforms is by considering the person vis-à-vis uniformed dress. In regards to appearance and bodily regulation, one's person is either *impressed upon* (by societal rules) or it *gives off impressions* (by subjective intention). There are, then, two angles from which self-presentation practices associated with uniforms can be approached. The first is “person as a mannequin”: one's body is inert, a passive object with clothes hung on it by others. The self is under control; one dresses for others. Roles and social status are imposed. The second angle is “self-governing”: one's body is animate, something active, a self-regulating entity. The self is in control; one dresses, as it were, for one's self. Personal style and individuality are expressed. Arguably, one's appearance is a mixture of both these forms of self-presentation, but it is worth highlighting the self-governing perspective in order to illustrate the role of individual agency. Such a maneuver is necessary to account for what might be termed “resistance” (though not necessarily of a well-thought-out, explicit kind). For example, Japanese schools are known for enforcing uniform regulations, and yet many students routinely flaunt the rules by affecting a slovenly look, donning nonregulation articles, and even altering uniforms. Such dress practices are not political statements about the state, capitalism, and “the system,” but rather



personal expressions of insolence aimed at teachers, parents, and what is perceived to be the old-fashioned style of the older generation.

Here the difference between dress codes and uniforms needs clarification. If “uniformity” is a crucial component of any definition of uniforms, it is prudent to envision a continuum of dress codes, dress uniformity, and uniforms. In many places, there is debate about how much uniformity is desirable, and regulations vary widely. Some school policies are very liberal, requiring that students follow a dress code that does not require uniforms, while others ask students to don uniforms, and still others mandate that all students wear uniforms (though students are allowed to opt out for religious or personal reasons). Policies can even go further; in Japan, some schools are notorious for strictly enforcing, in military-fashion, every component of dress, including skirt length, hair style and color, and book bags.

### Recent Historical Origins

Many British schools have a long history of school uniforms that have influenced school dress codes elsewhere (although the styles generally regarded as British school uniforms made their appearance in the late nineteenth century). By the early nineteenth century in Britain, the ensemble of student uniforms had more or less stabilized. At schools such as Eton and Harrow, a student uniform would include a short round jacket with deep lapels made of checkered woolen or strong cotton materials. By the 1920s, a typical boys’ uniform for middle and upper-class schools might consist of a gray flannel suit (or blazer) with breast pockets, “Eton collar,” school cap (or straw boater), and necktie with school colors. School badges or insignia would be affixed to the uniform. A typical girls’ uniform might consist of a low-waisted dress in navy wool, pleated skirt, white collar with navy silk bow, navy blazer, black stockings and shoes, and a panama hat. Popular colors were navy blue, black, brown, or dark green. In the late nineteenth century, the introduction of sports, games, and gymnastics into the curriculum resulted in the modification of girls’ uniforms.

Examples of dress uniformity among youth outside the school walls indicate broader cultural trends and attempts to acquaint children with the imperatives of formality, self-discipline, social order, and patriotism, as well as attempting to suppress working-class anomie and militancy. The uniforms of youth movements (such as Boy and Girl Scouts) illustrate these attempts. Another example is “sailor suits,” which relied on a generalized “military metaphor”—children will be “recruited into society” through uniformization. The popularity of sailor suits, originally introduced in schools that trained boys for Britain’s navy, spread to other countries (including Japan, where their influence can still be seen in girls’ uniforms) among both boys and girls of all ages during the late nineteenth and early twentieth centuries. Such continued popularity is arguably an illustration of how uniforms

generally preserve older, even obsolete, styles (for instance, boys’ uniforms in Japan are modeled on Prussian officer uniforms).

### School Uniforms in the United States

In the United States, dress codes were commonly enforced in schools in the 1950s (girls, prohibited from wearing pants, had to wear skirts or dresses). During the 1960s, blue jeans, black leather jackets, and other accoutrements associated with gangs were prohibited among boys (and, of course, girls as well). By the 1980s, problems with gang violence led to dress codes that attempted to do away with gang colors. Dress codes have routinely been used to prohibit clothes with threatening language, insulting racial slurs, and alcohol or drug-related messages. They have also been used to ban miniskirts, tube tops, halter tops, and see-through clothing (such restrictions raise an interesting gender issue; some note that they unfairly discriminate against women since male students supposedly face less bodily regulation). Uniform policies began to spread in the late 1980s and then steadily increased throughout the 1990s. Though parochial and private schools have a long history of mandating school uniforms, the first public-school system to require uniforms, California’s Long Beach Unified School District, has become a model for uniform policies in other places. Begun in 1994, this program involves about 60,000 elementary and middle school students.

An important symbolic push for school uniforms came in January 1996, when President Clinton endorsed their use during his State of the Union Address. One month later, the National Association of Secondary School Principals also endorsed them. Then, shortly after the presidential endorsement, the U.S. Department of Education sent a manual, “School Uniforms: Where They Are and Why They Work,” to all 16,000 school districts. The manual listed examples of model programs and explained what are perceived to be the benefits of school uniforms, such as improved discipline and a decrease in violence and gang activity.

By 2000, thirty-seven states had passed laws empowering local school districts to establish their own uniform policies, while numerous local authorities have instituted their own policies. Definite figures are hard to come by, but estimates of public schools that have adopted uniform policies range from 8 to 15 percent of American schools. Other estimates are even larger, and claim that nearly half of the large urban school systems in the U.S. have adopted school uniform policies for some or even all of their schools.

### Arguments for School Uniforms

Advocates of school uniforms possess a large array of arguments about why they are beneficial. Such arguments can be categorized into three types:

**Education-socialization benefits.** Supporters of school uniforms commonly cite improved discipline, increased



**Hong Kong boys in school blazers.** Elements of the typical British school boy's uniform, such as a flannel blazer with breast pockets adorned with the school emblem, can often be seen in the school uniforms of other countries. © JAMES MARSHALL/CORBIS. REPRODUCED BY PERMISSION.

self-esteem, and more school pride. Learning, rather than being distracted by “fashion wars,” becomes the focus of schooling (though some schools have adopted more casual styles for uniforms, which might include blue jeans). Peer pressure is reduced. Embarrassment from not being fashionable, teasing, and bullying is mitigated. Moreover, any pedagogical practice that encourages students to find their sense of self-worth in something other than outward appearance is highly welcomed by parents.

**Administrative benefits.** Some teachers and administrators claim they have witnessed a decline in disciplinary problems while they have seen an increase in solidarity and camaraderie in schools since everyone appears to be on the same “team.” Additionally, uniforms make it easier for school staff to identify who belongs on campus, thereby enhancing safety.

**Social engineering.** School uniforms act as “social equalizers,” hiding the differences between the “haves” and “have-nots.” Moreover, because parents do not have to contend with purchasing new clothes to keep up with constantly changing fads, educational expenses are kept down.

#### Arguments Against School Uniforms

Reasons against uniforms are fewer than those for, and usually include arguments about how uniforms dampen

freedom of expression and inhibit individuality. Some complain that, at schools with a uniform policy, teachers are burdened with being “fashion police.” There are also legal issues: Opponents contend that dress codes violate the constitutional right of freedom of expression (though court decisions have generally upheld the constitutionality of dress codes). Others argue that the push for uniforms is a superficial response to serious problems and distracts from more pressing educational needs, such as lack of adequate school funding, dilapidated facilities, and drug use.

There are significant legal implications between dress codes and uniforms that involve students' rights and freedom of expression. A dress code usually stipulates what cannot be worn (proscription), while a uniform policy stipulates what must be worn (prescription). In the United States, the courts have viewed the former more positively. However, mandating the wearing of school uniforms faces more of a constitutional challenge (see DeMitchell, Fossey and Cobb; Starr).

Some policy-makers in support of school uniforms report dramatic declines in suspensions, fighting, substance abuse, robbery, and assault on teachers in schools in which uniforms have been adopted. Despite these success stories, research on the results of school uniforms is still inconclusive. Indeed, several studies have argued that there is no empirical evidence that uniforms have a positive effect on student behavior or academic achievement. More sophisticated studies are needed that factor in sociological variables such as type of school, composition of student body, class size, and socioeconomic level of school districts.

#### School Uniforms in Japan

Major themes emerged from a study of the views of Japanese student on uniforms.

**Unity, integration, and solidarity.** The most common terms that came up in discussions about student uniforms were “integration,” “unit life” (*shūdan seikatsu*), and “solidarity.” McVeigh relates that students commented on the feeling of unity, *esprit des corps*, school identity, and, later corporate identity enhanced by uniforms.

**Social control and order.** Notions of social control and order were evident in how some students explained that uniforms make it easy to identify one's social role and to which unit one is affiliated. Additionally, students learn to follow rules, a benefit for when they enter society.

**Suppression of individuality.** On the negative side, McVeigh notes that a number of students tapped into the debate about how a dress code infringes upon their “human rights” and “freedom,” denying them “expression of personality” and diminution of individuality.

**Institutional face.** Many students made a strong association between uniforms and a school's “image.” Being a student means wearing the “institutional face” of a



**Girls in school uniforms.** School uniforms based on sailor suits, such as these, have retained popularity since their first use by schools that trained for the British navy. BRIAN J. McVEIGH. REPRODUCED BY PERMISSION.

school off-campus. Others explained that uniforms made them proud of their school and that a uniform is the “school’s face.”

**Being observed and monitored.** Some students reported that uniforms gave them a “consciousness of rules” and being under control (person as mannequin). Uniforms allow teachers to keep an eye on students who can thus be more easily monitored in public.

**Class distinctions and discrimination.** Not a few students felt that uniforms were important not for only instilling a sense of solidarity, but also for hiding class differences that might lead to jealousy. One student reported liking to wear uniforms in middle school, “But when I entered high school, I noticed that low- and high-ranked high schools all had their uniforms. If one attended a lower-ranked school, people had a biased view of you. So I think high schools shouldn’t have uniforms” (McVeigh 2000).

**Ethnonational identity.** Though it is very difficult to gauge to what degree uniforms construct ethnonational

identity, it is worth at least noting the linkages. McVeigh relates that one student explained how wearing a uniform made her “proud of being Japanese” while another said “uniforms protect Japanese culture.” Some students linked uniforms to supposedly Japanese “virtues” and “tradition” such as harmony, unity, and politeness.

### The “Consumerist Revolution”

The “who” and “why” of clothing guidelines changes the debate about uniformization. Militaries have used uniforms since ancient times, and policing and security forces have been more recently uniformed, while those subject to extreme control or sanction, such as criminals, paupers, and the mentally incapacitated, have been increasingly regulated during the last two centuries. Such practices of bodily regimentation are more or less uncontroversial. However, debates and discussions about the uniformization of youth are more contentious and will not soon disappear.

From a more scholarly perspective, student uniforms are significant because they implicate a number of concerns that still require investigation. These include how



to disentangle—or link up—socialization, power, personhood, and self-presentation. Such topics deserve attention since they come together in what may be termed the “consumerist revolution.” This is the emergence since the nineteenth century of what seem to be two contradictory trends that nevertheless mutually reinforce each other: (1) the desire or right to have choices over one’s consumerist practices (wearing or not wearing certain articles of clothing; person as self-governing agent); and (2) the imperative to signal one’s allegiance using clothing to the politico-economic machinery that produces these very choices (person as mannequin). As an instance of material culture, school uniforms offer a visible, concrete manifestation of this paradoxical historical development. Herein lies their significance.

See also **Academic Dress**.

#### BIBLIOGRAPHY

- Brunsmas, David L., and Kerry A. Rockquemore. “Effects of Student Uniforms on Attendance, Behavior Problems, Substance Abuse, and Academic Achievement.” *Journal of Educational Research* 92, no. 1 (September/October 1998): 53–62.
- Cunnington, Phillis, and Anne Buck. *Children’s Costume in England*. London: Adam and Charles Black, 1965.
- DeMitchell, Todd A., Richard Fossey, and Casey Cobb. “Dress Codes in the Public Schools: Principals, Policies, and Precepts.” *Journal of Law and Education* 29 (January 2000): 31–50.
- Joseph, Nathan. *Uniforms and Nonuniforms: Communication through Clothing*. New York: Greenwood Press, 1986.
- McVeigh, Brian J. *Wearing Ideology: State, Schooling, and Self-Presentation in Japan*. Oxford: Berg, 2000.
- Nunn, Joan. *Fashion in Costume, 1200–1980*. London: The Herbert Press, 1984.
- Starr, Jennifer. “School Violence and Its Effect on the Constitutionality of Public School Uniform Policies.” *Journal of Law & Education* 29, no. 1 (January 2000): 113–118.
- Tanioka, Ichiro, and Daniel Glaser. “School Uniforms, Routine Activities, and the Social Control of Delinquency in Japan.” *Youth and Society* 23, no. 1 (January 1991): 50–75.
- Wade, Kiley K., and Mary E. Stafford. “Public School Uniforms: Effect on Perceptions of Gang Presence, School Climate, and Student Self-Perceptions.” *Education and Urban Sociology* 35, no. 4 (August 2000): 399–420.

#### Internet Resource

- “School Uniforms: Where They Are and Why They Work.” U.S. Department of Education. Available from <<http://www.ed.gov/updates/uniforms.html>>.

Brian J. McVeigh

**UNIFORMS, SPORTS** Since the time when humans were able to stand upright, running has been an activity conducted for survival, in order to hunt for food and escape danger. In terms of competitive-running (track and

field) events, the Ancient Olympics (776 B.C.E.), in Olympia, Greece, probably best document the history of running. The Olympics are typically associated with feats of superior athleticism and hundreds of sporting events, but the first Olympics were one-day religious festivals to celebrate the gods (specifically Zeus) that the Hellenic society worshiped. The “single foot race” (which covered one length of the stadium) was the only sporting competition until the fifteenth Olympiad. As the Olympic festival expanded, other sports like chariot racing, boxing, and pentathlon were added. Married women, who were forbidden to look at other men, were banned from the festival and were killed if they were caught attending. Virginal women were allowed to attend the Olympics so they could see what the ideal man looked like, and they had their own sports competition called the Heraean festival (after the goddess of Hera), where javelin throwing was a popular competition. All of the athletes participated in the nude (for ease of movement) and wore no foot protection. The branch of a wild olive tree was the official prize for an Olympic winner (Hickok Sports 2004).

The modern Olympics were revived in April 1896 and in the early 2000s they include twenty major track and field events (not including separate events for men and women). At the first modern events, the track and field dress consisted of woven shorts and knitted tank tops with colored athletic striping to identify athletes by country. Athletes wore leather track spikes that were constructed much like a traditional men’s dress shoe with nails on the sole for traction. Twenty-first-century track and field athletes wear uniforms that are very lightweight, breathable, and aerodynamic. There are two trends. One is that the athlete wears as little as possible, so that the body is almost nude—reflecting the dress of the original Olympic athletes. Men who follow this philosophy wear body-conscious polyester and spandex knit shorts and a tank top. Women wear body-conscious polyester and spandex knit briefs and a sports bra top. The other trend is to cover the entire body (including the head) in aerodynamic body-conscious polyester and spandex knit “skin” where the athlete is theoretically making the body more “fluid,” so that it has less resistance (drag) from the racing environment. This particular uniform technology is also seen in swimming, ski racing, and speed skating. For most of the running events, lightweight track spikes are worn to help propel the athlete over the running surface. In longer running events like the marathon, a lightweight racing flat is worn, which is constructed more like a modern day sneaker. For the field events, like discus and javelin, the athletes wear sport-specific footwear or ones that have been customized.

#### Football (Soccer)

Football or soccer is another sport that has a long history. Some historians credit the Chinese with the earliest form of football in 255–206 B.C.E. The sport was called Tsu Chu, and it was used to train soldiers as part



**The production of jockeys' hats and shirts.** Like the bright colors worn by a jockey, many sports' uniforms serve the purpose of enabling easier differentiation between players. © HULTON-DEUTSCH COLLECTION/CORBIS. REPRODUCED BY PERMISSION.

of their physical education program. Many societies including the Ancient Greeks, Aztecs, Romans, Japanese, and Egyptians have claimed to be the creators of football too, as any sport where a ball is kicked is seen as a predecessor to the modern sport (Miers and Trifari 1994 p. 26; Langton 1996, p. 15–27). The object of modern-day football is to move a single ball, by passing it between players, and kicking it into an opponent's goal. At the end of a ninety-minute game, the team that has the most goals wins the game. Hands cannot be used to pass the ball, as seen in rugby or American football. The sport is played between two teams, with eleven athletes on each team. Football as we know it in the early 2000s is based upon rules and regulations formed in London, England, in October 1863 by delegates from the Association of Football (Miers and Trifari 1994, p. 36–37).

The first modern day uniforms (1860s to 1880s) consisted of wool or cotton knickers, a woven or knitted pullover (typically with a buttoned welt opening), knee-length socks, a cap, and leather-work boots with leather

or metal cleats. Some teams utilized colored stripes as a way to identify their team and because they were easy to incorporate into a woven or knitted material. Other teams had badges that were sewn onto their jersey (usually on the left side of the chest) for further identification. The sport was played with a round, leather ball that was inflated with a pig's bladder. Shin guards were not widely used during this time. In the latter part of the 1800s, woven shorts became popular, as they provided better freedom of movement. The use of woven materials for jerseys became less and less visible as the game evolved into the early 1900s. The use of wool declined, and synthetic fibers were more relevant (for laundering, durability, and comfort). Shin guards were more and more visible on players, but not mandatory until 1984. The original guards were made of leather and boning with horsehair stuffing, where twenty-first-century guards are made of synthetic plastics and high-performance foams. Football jerseys, shorts, and socks are made of high-wicking fibers and are designed to allow the athlete to move with efficiency and

accuracy. The uniforms contain very little or no seaming and accessory pieces (buttons and zippers). The football “boot” is really a shoe-type construction with cleats or studs that is streamlined in design to help the player control the ball and run fast. Ball technology has changed the game most. The lighter the ball becomes, the faster the game becomes. Goalkeepers prior to the 1970s never wore goalkeeper gloves. But with players and ball technology, the ball can be kicked at speeds around 100 mph and the goalkeeper needs his or her hands protected with foam gloves. Uniform styles also include player numbers, names of the player on the back of the jersey, sponsorship, and club badge. There are also home and away uniforms. Many sport brands and football clubs have their own game-day and lifestyle collections that enable fans to wear their favorite team or player’s colors as a supporter outside the stadium and as a fashion statement.

### Cricket

Shepherds from the southeast of England are recognized as the creators of cricket in the 1300s. They played a game on the short grass pastures where it was possible to bowl a ball of wool or rags at a target. The target was usually the wicket gate of the sheep pasture, which was defended with a bat in the form of a shepherd’s crooked staff. Records show that King Edward II was a fan of the game, as well as Oliver Cromwell. It was a sport adopted and appreciated by the upper class, and there are gambling records from 1751 showing bets made on matches exceeding £ 20,000 (Lords 2004). In an effort to formalize how the sport was played, rules and regulations were formed in 1787, at the Marylebone Cricket Club (Farmer 1979).

The objective of cricket is quite complicated, as it is based upon a multitude of rules and regulations. To simplify,

cricket is a team sport for two teams of eleven players each. Although the game play and rules are very different, the basic concept of cricket is similar to that of baseball. Teams bat in successive innings and attempt to score runs, while the opposing team fields and attempts to bring an end to the batting team’s innings. After each team has batted an equal number of innings (either one or two, depending on conditions chosen before the game), the team with the most runs wins. (Mar)

The traditional dress (sometimes referenced as “creams”) worn for cricket is cream or white in color, symbolizing cleanliness, confidence, and keenness (Dunn et al. 1975). All players typically wear cotton/polyester trousers and a buttoned-down cotton/polyester shirt. Some will wear a cable or heavy rib-knitted V-neck vest or sweater (also in cream or white). White shoes or “boots” for cricket are worn, which look like golf shoes and serve a similar purpose of providing traction. Protective batting gloves, thigh pads (worn on the inside of the trousers), and combination thigh, knee, and shin pads

(worn on the outside of the trousers) are worn to protect the player from ball impact. Each batter has a wooden bat that is shaped long like a baseball bat, but has a flat surface for hitting. In the past caps were worn more than helmets and sometimes players did not cover their heads at all. Helmets are worn for impact protection, but even in the late 1970s many players thought they were not “manly.” One reference states: “If a senior player feels sufficiently unnerved by the speed of a fast bowler then there is nothing in the rules to prevent him placing one on his head. But avoid the indignity if you can” (Farmer 1979, p. 10). Some international matches are played in football (soccer)-styled uniforms with colorful jerseys and trousers. Some traditionalists feel that these uniforms disrespect the heritage and eliteness of the sport, as football was traditionally a sport for the working class.

### Rugby

Rugby is a version of football (soccer) where players are allowed to carry the ball with their hands. The sport originated at the Rugby School in England with a sixteen-year-old student named William Webb Ellis who picked up and carried the ball during a football (soccer) game in 1823. Some say that Ellis was inspired by the Irish-native game called Caid (where Ellis’s father was stationed with the Third Dragoons guards). The sport was adopted in the 1860s by other schools and universities in England, and by 1871 the English Rugby Union was formed to standardize the rules (Trueman). The basic objective of the sport is that two teams, of fifteen players carry, pass, kick, or ground a ball to score as many points as possible. The team with the most points at the end of a match wins. Rugby became associated with the British upper class, whereas football (soccer) was the sport of choice for the working class, because of its origin at private schools and universities. This is quite ironic, since the game of rugby requires enormous physical strength, extensive physical contact, and is often played in the mud (created by inclement weather).

The original game was played with a round leather ball that had a pig’s bladder. Since rugby was originally a schoolboy’s sport, the school uniform was typically worn to play in. In the 1800s the upper-class school uniform consisted of a top hat, white trousers, braces (suspenders), black jacket, white shirt, and a tie. Black leather shoes or boots complemented the outfit. Everything except the top hat and jacket were worn to play rugby. Boys even tried to take the “newness” out of their school uniforms by getting them extra dirty while playing. At the end of the 1800s, knicker-length trousers in darker colors became popular for their ease of movement and ability to hide dirt. Caps were worn on the head in team colors, often with badges. Collarless jerseys (sometimes with a leather yoke) with numbers were seen in the early 1900s. The advent of synthetic fibers and knitted materials allowed for more comfortable uniforms in the 1900s. The rugby game in the early 2000s is played with an oval



ball, a bit blunter in shape than the modern American football. This shape allows the ball to be easily bounced and drop-kicked. Cleats similar to the ones worn for football (soccer) are also worn to help the player run fast and establish traction with the ground, especially if it is muddy. Players who are larger and play defense wear a higher-cut version for ankle stability. A horizontally striped polo shirt design (with long sleeves), with three to four rubber buttons down a center front welt became known as the “rugby shirt” and was worn by players with traditional athletic shorts. Sporty teens and college students adopted this design in the 1970s, and again in the early 1990s. At the 2003 Rugby World Cup, teams were seen wearing body leotards that prohibited the opponent from grabbing and tugging down players during a match. Many players still do not wear any impact protection. The players who do, wear lightweight helmets, rib, and shoulder pads. Gloves are also worn to protect the hands and provide extra grip, while some players still choose to only tape their wrists and fingers. Some players tape their ears to prevent cauliflower ear.

### Baseball

Like football (soccer) many ancient societies had some sort of game that could be linked to the sport of baseball. Most historians believe baseball is based on the English stick and ball game of rounders. In the early 1800s the sport became very popular in America and it was known by numerous names including townball, base, or baseball. Many small towns formed teams, and baseball clubs were formed in larger cities. By 1845 Alexander Cartwright formalized the rules of baseball, and in 1846 he organized the first recorded baseball contest (between the Cartwright Knickerbockers and the New York Baseball Club) at Elysian Field in Hoboken, New Jersey (Bowman and Zoss 1986, p. 10–11). The basic idea of baseball is to hit a ball that is pitched by an opposing team’s pitcher with a wooden bat and get around three field bases to make a run (score) without getting caught. After nine innings, the team with the most runs wins the game.

The baseball uniform has a very rich history. The Knickerbockers adopted the original uniform in 1849, and it consisted of a white flannel collared shirt, woolen trousers, a straw hat, and leather shoes. Like other sports in the late 1800s, knickers were adopted (for more comfort) and leagues soon used color and patterns (like stripes and checks) to identify players, positions, and teams. At the turn of the twentieth century, team badges and names were on almost every player’s shirt. The baseball shoe became a high top with cleats for better ankle stability and traction. The straw cap was now made of wool. The shirt collar was removed for more comfort and numbers were added on the sleeve for further player identification. In the 1940s, the All-American Girls Softball League was formed, and women wore uniforms featuring belted short-sleeved tunic dresses with caps. Player names were

added in the 1960s to the back of the jerseys (along with numbers) (National Baseball Hall of Fame). In the twenty-first century, the uniform is reminiscent of the original uniform in that it consists of a shirt or jersey and trousers, but they are constructed with nylon or polyester fibers and are often knitted, which allows them to fit very close to the body. Trousers typically have stirrups, which allude to the look of the old-fashioned knickers. Jerseys are still closed up the center front and are either short sleeved or sleeveless to allow a cotton T-shirt to be worn underneath for heat management. Players still wear caps (typically they are made of cotton and polyester fibers), and helmets are now used for impact protection when batting.

### Basketball

Dr. James Naismith, a Canadian Presbyterian minister, invented the sport of “Basket Ball” on 21 December 1891 at a Springfield, Massachusetts, YMCA Training School in response to a work assignment that required him to create a sport that could be played indoors during the winter (Naismith Memorial Basketball Hall of Fame, Inc.). Naismith’s idea was to utilize athletic skill instead of strength like in American football or rugby. With thirteen rules, the basic object of Naismith’s new sport was to put a ball in an opponent’s “basket.” At the end of the game, the team with the most baskets wins. The first game of basketball was played with eighteen players (nine to a team) and used a football (soccer ball), and two peach baskets as the goals (Wolff 1991, p. 7–13). Women were involved in the game almost immediately, and Smith College in Northampton, Massachusetts, was the site of the first collegiate women’s basketball game in 1893. Although there have been some major changes to the game since it was first invented, it is still one of the most popular games played. Over 300 million people play basketball in the early 2000s (Naismith Memorial Basketball Hall of Fame, Inc.).

The original basketball uniform consisted of everyday clothing that boys would wear to school, like a pair of full-length trousers, a buttoned-down shirt, and leather shoes. Over a period of twenty years, specific team uniforms were created for men to identify team names and colors. The first uniforms were composed of a knitted pullover with appliquéd team letters or names, knicker-length woven trousers, knitted striped knee socks, and leather shoes. The uniform soon reduced itself to a pair of woven short-shorts, a knitted tank top, leather kneepads, knee socks, and basketball sneakers like the Converse All-Star. For women, the first basketball uniforms consisted of large belted black bloomers that extended below the knees with stockings and white middie shirt. In the twenty-first century, basketball uniforms for men and women are almost identical, less complicated, and protective. They use nylon and polyester and material constructions to provide thermal comfort on the court. A typical uniform consists of a sleeveless knitted

jersey tank, shorts that are almost knee-length, ankle-length socks, and basketball sneakers. Furthermore, each player's uniform typically has a number on the front and back of the jersey for identification on TV and for spectators. Sometimes the player's surname is printed on the back of the shirt for further identification. Basketball sneakers are built to provide traction on the wood court floor and ankle stability from medial-to-lateral movements.

### American Football

The sport of American football derived from rugby. Football (soccer) has also been noted as a cousin to American football. The sport came to America in the mid-1800s and was played by many northeastern colleges, like Harvard, Yale, Princeton, and Columbia. In 1876, Harvard and Yale Universities met together in Massachusetts to formalize the rules of American football. The object of the game was to move an oblong-shaped ball across a goal line by kicking, throwing, or running with it. The team that can get the most points in four quarters wins. The game is played between two teams, each with eleven players. In American football, the teams can be rotated in and out of the game, which is different than football (soccer) and rugby.

In the beginning of the Professional Football League in the 1920s, there were no rules regarding the equipment players wore. Teams only provided players with long-sleeve knitted wool jerseys, and socks in team colors and logos. Many players used the equipment that they acquired at university (if they went). To protect the head from contact, players wore soft, pliable leather "head helmets" with nose guards, while some players felt that long hair was good enough. Pants were knicker-length and were made of brown cotton canvas (reminiscent of the original Levi's). Players also wore cleats to enhance traction when running, especially in the mud (McDonough et al. 1994, p. 31.). Throughout the 1900s elaborate equipment was developed for the player, including pads made with high-density plastics and foams for the neck, thighs, hips, groin, ribs, knees, shoulders, and sometimes the forearms. Over the protection, the player usually wears a knitted jersey, knee-length pants, and socks, in team colors and made of synthetic fibers that provide durability and thermal comfort. Like in many other sports, jerseys contained the name and number of the player and team logo for on-field identification. Many of the equipment developments during the last century were created by players themselves or by equipment managers. Players in the early 2000s wear proper, durable helmets with face and mouth guards (McDonough et al. 1994, p. 110). Lightweight cleats are worn for different field environments like grass or synthetic turf. Gloves are sometimes worn for warmth and to provide a better grip on the ball. Even the ball has gone through a series of changes, making it more durable, aerodynamic, and easier to handle.

See also **Sneakers**.

### BIBLIOGRAPHY

- Bowman, John, and Joel Zoss. *The Pictorial History of Baseball*. New York: Gallery Books, 1986.
- Dunn, John, et al. *How to Play Cricket: Australian Style*. Hong Kong: Souvenir Press, 1975.
- Farmer, Bob. *How to Play Cricket*. New York: Hamlyn, 1979.
- Langton, Harry. *1000 Years of Football: FIFA Museum Collection*. Berlin: Edition Q, 1996.
- McDonough, et al. *75 Seasons: The Complete Story of the National Football League 1920–1995*. Atlanta, Ga.: Turner Publishing, 1994.
- Miers, Charles, and Elio Trifari. *Soccer! The Game and World Cup*. New York: Rizzoli International, 1994.
- Wolff, Alexander. *100 Years of Hoops: A Fond Look Back at the Sport of Basketball*. New York: Bishop Books, 1991.

### Internet Resources

- Hickok Sports. 2004. *Sports History: The Ancient Olympic Games*. Available from <<http://www.hickoksports.com/history/olancien.shtml>>.
- Mar, David. *An Explanation of Cricket: Rules and Game Play Described for Novices*. Available from <[http://www.cricinfo.com/db/about\\_cricket/explanation/explanation\\_of\\_cricket.html](http://www.cricinfo.com/db/about_cricket/explanation/explanation_of_cricket.html)>.
- Naismith Memorial Basketball Hall of Fame, Inc. *Naismith Memorial Basketball Hall of Fame: History*. Available from <<http://www.hoophall.com>>.
- National Baseball Hall of Fame. *Dressed to the Nines: A History of the Baseball Uniform*. Available from <[http://www.baseballhalloffame.org/exhibits/online\\_exhibits/dressed\\_to\\_the\\_nines.htm](http://www.baseballhalloffame.org/exhibits/online_exhibits/dressed_to_the_nines.htm)>.
- Trueman, N. *Rugby Football History: Timeline*. Available from <<http://www.rugbyfootballhistory.com>>.

Susan L. Sokolowski

**UNISEX CLOTHING** The term "unisex" as applied to dress was coined in the late sixties to denote clothing suitable or designed specifically for both males and females. Prior to this, fashion most traditionally contextualized stood for the clear demarcation of the sexes through the reaffirmation of gender identity. Simply put: women wore skirts, and men wore pants. Although historically there were of course experiments in appropriation, the decade that produced the Youthquake solidified the idea of universal dress.

Denim jeans and T-shirts, popularized in the 1950s by Hollywood cinema, inaugurated the democratization of clothing. Up until that point, they had served as working-class garments that signified a particular niveau in society. For the burgeoning younger generation, the seductive charm of young actors like Marlon Brando and James Dean, combined with the powerful vehicle of motion pictures, transformed jeans and T-shirts not only

into fashion phenomena, but perhaps the first truly accepted unisex articles of clothing.

The seeds of youth revolution, planted in the 1950s, fully blossomed the following decade. The 1960s were a period of extraordinary change—one in which conventional notions of age, gender, and class were completely redefined. In an environment conducive to experimentation, the era pushed designers to incorporate new definitions of youth and universality into their work. The idea of unisex, in particular, gained currency precisely for its implications of multifaceted freedom. In the obvious sense, unisex meant liberation from gender, but more importantly, its association with the future in its disavowal of traditional hierarchies and old-fashioned attitudes made it a major driving force for fashion.

### Key Designers

The 1960s not only brought the Youthquake, but it was also the age of space exploration. All aspects of society were affected by it—including fashion, which was directly reflective of the times. Placing a big importance on minimalist design, geometric construction, the use of synthetic materials, and the idea of unisex, designer Pierre Cardin revolutionized fashion by creating futuristic clothing fit for the space age. He produced single-breasted, round-necked jackets, stretch jersey tunics, and leggings for both sexes and dressed men and women alike in unitards and jumpsuits accessorized with rounded helmets and flat plastic eye shields.

Like his contemporary Cardin, Rudi Gernreich flourished in a time when political and social unrest called for the re-mapping of gender identity. Often labeled the “inventor” of unisex fashion, Gernreich explored male and female representation in society by playing with established ideals. His unisex project erased the line dividing the sexes through de-emphasizing the importance placed on sexual attributes and rendering them banal. The centerpiece of the unisex project was the monokini—a one-piece topless bathing suit intended to be worn by men or women who had shaved off all head and body hair.

### Impact of Unisex

The concept of unisex has far-reaching implications because it disturbs society on such a basic level. Fashion becomes a powerful tool in subverting sexual identity through connotations of dress. Throughout history and with varying degrees of success, designers have challenged conventional dress codes. In the 1920s, Chanel envisioned a new femininity in fashion that incorporated trousers—the symbol of masculine power. However, it was not until the Women’s Liberation movement of the 1970s that pants were universally accepted as female attire. From this point forward, the impact of unisex expands more broadly to encompass various themes in fashion including androgyny, mass-market retail, and conceptual clothing.

**Androgyny.** Androgynous habits of cross-gender impersonation date back to the privileged classes of seventeenth- and eighteenth-century England and France; however, after the industrial revolution and the subsequent rise of capitalist societies, a fairly structured dress code dividing men and women re-emerged. The next great revolution in fashion—the Youthquake of the 1960s—would shatter those gender ideals. The sixties’ premium on youth led the way for fashion that was neither specifically feminine nor masculine. From space age to hippie, the idea of dressing was less about being boyish or girly than it was about an overall frenzy of youth fascination.

The 1970s continued with the exploration of gender both underground and in the mainstream. In fashion proper, Yves Saint Laurent advocated the masculine look for women while the subcultural movements of punk and glam rock established, at least visually, an identity through androgynous dress. Further, in the 1980s, Jean-Paul Gaultier sent men and women down the same catwalk in similar-style sarongs and pant-skirts inspired by the Orient. Simultaneously, the new-wave movement fused punk and glam-rock influences to create the next generation of unisex fashion.

In the contemporary moment, the styles of the 1970s and 1980s live on through countless retro revivals, but the pioneer of a new type of androgyny, one reborn in luxury lines, is Hedi Slimane, designer of Dior Homme. Slimane reworks men’s classic tailoring through subtle detailing, and his collections have become coveted internationally by both chic men and women. As he himself states, “I think it’s all a state of mind. Who cares whether a guy or a girl wears the garments? This masculine/feminine dialectic doesn’t interest me—in my head, we’re all a little bit of both” (eLuxury.com May 2003).

**Mass-market retail.** Retailers such as The Gap (incidentally born in revolutionary 1969) have produced wildly successful globally marketed clothing lines founded on a basic range of simple unisex separates: T-shirts, jeans, trousers, sweaters, and jackets. Their domination of the clothing market stems from their affordability, accessibility, and their capacity to transcend age, gender, and perhaps most importantly, trends. The Gap’s consistency in design and marketing guarantees the firm’s continual growth and success in a climate where the average consumer seeks more and more to dress in affordable, comfortable, casual wear that will stand the test of time.

**Conceptual mode.** The avant-garde in fashion has historically generated design based on a framework of conceptual ideas, converting theories into architecture for the body independent of gender. Ernesto Thyayht worked with fashion under the Futurist conviction that society could only be revolutionized through aesthetics. Fashion bridged the divide between the avant-garde and the masses. In the early 1920s Thyayht created the unisex garment known as the *tuta* that was similar in design



to Russian Constructivist uniforms. The *tuta* was monotone, varied in fabric depending on the season, and was worn without an undershirt for all occasions.

The legacy of such experiments in fashion was rediscovered in various contexts from the 1980s onward. In contrast to the glitz and glamour of western fashion in the eighties, Japanese designers Rei Kawakubo and Yohji Yamamoto created collections the press dubbed as the “post-Hiroshima look.” In a reaction to the hyper-feminized sexuality ubiquitous in European and American fashion, Kawakubo and Yamamoto designed genderless, loose, asymmetric and irregular clothing in black that placed a primacy on garment construction.

Conceptual fashion evolved the following decade with Belgian deconstructionists, most notably Ann De-meulemeester and Martin Margiela. Deconstruction revealed the process of tailoring, shape, and construction through surpassing gender codes and questioning body proportion. While traditional fashion physically reinforces sexual codification, these movements took the notion of gender identity away from clothing and reinserted the importance of garment fabrication and the conceptual origins of creation.

See also **Futurist Fashion, Italian; Space Age Styles.**

#### BIBLIOGRAPHY

- Davis, Fred. *Fashion, Culture, and Identity*. Chicago and London: The University of Chicago Press, 1992.
- Derycke, Luc, and Sandra Van De Veire, eds. *Belgian Fashion Design*. Bruges: DieKeure, 1999.
- Hebdige, Dick. *Subculture: The Meaning of Style*. London and New York: Routledge, 1987.
- McDowell, Colin. *Fashion Today*. London: Phaidon Press Ltd., 2000.
- Steele, Valerie. *Fifty Years of Fashion: New Look to Now*. New Haven, Conn.: Yale University Press, 1997.
- Vinken, Barbara. “Transvesty-Travesty: Fashion and Gender.” *Fashion Theory* 3, no. 1 (1999).

*Jennifer Park*

**UZANNE, OCTAVE** Octave Uzanne (1852–1931) was a French writer and bibliophile, or book lover. Editor of several journals, such as *Le livre* (The Book), and founder of bibliophile societies that published illustrated books, he was also a prolific author who specialized in the art of making beautiful books. As of the early 2000s Uzanne is an obscure literary figure, remembered if at all as the author of a short story called “The End of Books” (1895), which foresaw how new technologies might result in such inventions as the audiobook. Yet he also produced a rich, albeit still neglected, body of work that helped to provoke discussion of fashion and femininity in fin-de-siècle France.

Uzanne was obsessed with women’s fashions, which he described with ardent, even fetishistic attention to detail. Fashion, he insisted, was woman’s only “literature,” and he himself the only true “historian” of women’s fashions. It is characteristic of Uzanne’s work to regard fashion and femininity as inextricably linked. He revived the term *féminie* to describe everything that fell within the domain of woman—beauty, love, and fashion—and his reputation as a fashion authority was closely associated with his supposed expertise in female psychology. The famous dandy Jules Barbey d’Aureville, who wrote the preface to Uzanne’s second book, *Le bric-à-brac de l’amour* (1879), told him, “Monsieur, you have *le sentiment de la femme*. You have what no one has anymore in our frigid era: You have an amorous imagination.”

Uzanne’s first and perhaps most famous book in the fashion genre was *L’éventail* (The Fan); (1882), a charming illustrated history of the fan. He admitted that his book was “not by any means a work of mighty wisdom and erudition,” but merely the first of a projected series of “little books for the boudoir.” Totally ignoring the use of the fan by East Asian men, Uzanne preferred to see it as the quintessential feminine accessory, “the scepter of a beautiful woman.” His next book, *L’ombrelle, le gant, le manchon* (The Sunshade, the Glove, and the Muff); (1883), was also illustrated in rococo style by Paul Avril. Uzanne’s tone continued to be playfully erotic. “The muff!” he exclaimed. “Its name alone has something adorable, downy, and voluptuous about it.” Regrettably, he never wrote his promised book on shoes and stockings, although he later published *Les ornements de la femme* (Woman’s Ornaments), which reproduced in one volume the combined texts of *The Fan* and *The Sunshade, the Glove, and the Muff*, both of which were also translated into English and published in London.

*Son Altesse la femme* (Her Highness, Woman); (1885) was an even more luxuriously produced book, with full-color illustrations by contemporary artists. Its subject, Uzanne wrote, was “the psychological history of the Frenchwoman from the Middle Ages to the present day.” Her psychology, Uzanne implied, was quite sexual and therefore dangerous to mere men. Félicien Rops, best-known for his erotica, illustrated Uzanne’s chapter on the medieval woman with a picture of a nude courtesan. One of Uzanne’s favorite periods, the eighteenth century, was interpreted as a time of erotic dalliance, when upper-class Frenchwomen changed lovers as easily as they changed dresses.

*La Française du siècle* (The Frenchwoman of the Century; 1886) focused on the years since the beginning of the French Revolution in 1789. Uzanne drew on a host of memoirs of the period to create a dramatic picture of changing modes and manners. For example, his chapter on the latter part of the French Revolution, known as the Directoire or Directory, included descriptions of such events as the *bal des victimes*. These bals were parties attended only by people who had at least one relative who

had been guillotined during the Reign of Terror. Women cut their hair short, as though they too were about to be guillotined; some even wore a ribbon of red satin around their necks.

Uzanne later republished what was essentially the same book under at least two different titles: *La Femme et la mode. Métamorphoses de la parisienne de 1792 à 1892* (Woman and Fashion: Metamorphoses of the Parisienne, 1792–1892); (1892) and *Les Modes de Paris. Variations du goût et de l'esthétique de la femme, 1797–1897* (literally *Fashions in Paris*, but translated into English as *Fashion in Paris. The Various Phases of Feminine Taste and Aesthetics, 1797–1897*]; (1897)). As these various titles indicate, women and fashion were virtually interchangeable concepts for Uzanne, at least with respect to Frenchwomen, or Parisiennes, whom he chauvinistically regarded as the most feminine of all women. Significantly, he also emphasized the importance of the specific venues within which fashion-oriented behavior occurred, such as the promenades in the Bois de Boulogne and the annual painting exhibitions at the musée du Louvre.

In the meantime, Uzanne wrote *La Femme à Paris*, translated into English as *The Modern Parisienne*; (1894), one of his most significant books. In this work, he moved beyond the restricted world of fashion to explore the lives of women at all levels of French society. Many working women in Paris were employed in some branch of the fashion industry, and Uzanne did considerable research into the lives of dressmakers and saleswomen as well as female artists, actresses, bourgeois housewives, and, of course, sex workers—from common prostitutes to expensive courtesans. In 1910 he republished *La Femme à Paris* in a cheap edition under the title *Parisiennes de ce temps*.

Many of Uzanne's books were masterpieces of the art of bookmaking, lavishly produced in numbered edi-

tions for collectors. He was solicitous of every detail from the typography to the paper and the design of the cover. His book *Féminies* (1896), for example, was a deluxe publication featuring numerous striking color illustrations by Félicien Rops. As previously mentioned, Uzanne revived the word *féminie* to refer to everything in the domain of women (beauty, love, fashion), claiming that it was now necessary to use the plural since there existed so many "gynecological republics." The cover illustration of *Féminies*, influenced by symbolist art, depicted a woman piercing a rose with a dagger.

By the early twentieth century, Uzanne was reduced to publishing small and inexpensive editions of his books. *L'Art et les artifices de la beauté* (The Art and Artifices of Beauty; 1902), for example, contained only black-and-white illustrations. In a series of chapters on such subjects as cosmetics, hairstyles, corsets, jewelry, and underwear, however, Uzanne continued to explore the ways in which fashion and artifice constructed feminine beauty.

*See also* **Dandyism; Fashion, Historical Studies of; Fashion, Theories of; Paris Fashion.**

#### BIBLIOGRAPHY

The books by Uzanne mentioned in this essay are all out of print and generally available only in large research libraries. No book-length study of Uzanne has been published as of early 2004. For Uzanne's era, however, the reader may consult the following works:

Steele, Valerie. *Paris Fashion: A Cultural History*. 2nd ed. Oxford, New York, and Tokyo: Berg/Oxford International Publishers, Ltd., 1998.

Weber, Eugen. *France, Fin de Siècle*. Cambridge, Mass.: Harvard University Press, 1986.

*Valerie Steele*



**VALENTINA** Working in New York City from the mid-1920s until 1957, Valentina Sanina Nicholaevna Schlée (known professionally as Valentina) was one of a very small, select coterie of mid-century female designers who achieved commercial success and maintained influential careers during the formative years of American fashion.

Working for a carefully chosen, exclusive clientele, Valentina turned out exquisitely cut and constructed evening, cocktail, and day ensembles that were commissioned and crafted in the manner of the French haute couture; every Valentina creation was made to order and was subject to multiple meticulous fittings and hand-finishing until the designer deemed the resulting garment worthy of her label. Known for her floor-gracing, draped, silk jersey gowns; body-skimming evening dresses with low-cut backs; deep décolleté; and bolero evening ensembles, Valentina also designed pared-down day dresses, linens, and undecorated cocktail dresses—all of which exuded a frank, forward-looking minimalist aesthetic.

### **Early Life and Marriage**

Born in 1904 in the Kiev region of Russia, Valentina escaped the revolution in the late teens with her new husband and soon-to-be business manager, George Schlée, arriving in America in 1923 after several years spent in Paris, Athens, and various other European cities. Much like the French designer Coco Chanel, who offered as many versions of her colorful past as her admirers cared to indulge, Valentina was prone to invent and embroider her early life as it suited her. As a result, Valentina's origins are shrouded in mystery. But as one delves further, it becomes increasingly clear that this mystery is largely of her own making.

While U.S. immigration records indicate that she and her husband were affiliated with a traveling dance troupe known as the *Revue Russe*, Valentina was not above stretching that period to “her time in Paris with [dance impresario] Diaghilev.” One account of her life after escaping Russia finds her dancing as part of a cabaret act with the *Chauve Souris* theater group in Paris. And while the *Chauve Souris* and the *Revue Russe* were hardly Diaghilev, one thing is certain: Valentina's early training as a performing artist played a critical role in the forma-

tion of her talent for costuming actors as well as her uniquely dramatic personal style. Graced with an undeniably compelling natural beauty, and enhanced by a theatrical presence, Valentina became as famous for the disciplined elegance and reductive simplicity of her clothing as she was for her meticulously crafted public persona. Self-created in virtually every aspect of her existence, Valentina offered an exotic beauty and charmingly mangled English that played to her favor in America, adding a veil of dazzlingly misleading allure to an already intriguing personality.

### **Formation of Valentina Gowns**

In operation from 1928 to 1956, *Valentina Gowns, Inc.*, was preceded by two early businesses, one the mid-1920s operating under the spelling “Valentena,” and another venture called “Valentina & Sonia.” Both of these concerns had folded by 1928 when *Valentina Gowns* was formed on more solid ground—this time backed by the Wall Street lawyer and financier Eustace Seligman. With George Schlée as business manager and Schlée's extended family employed in the workrooms, what became the most exclusive and most expensive American house of couture actually began as a rather simple, family-run business under the shrewd and watchful eye of the firm's only designer, Valentina.

Providing a formidable livelihood for the entire Schlée family, Valentina and George lived with great flair and panache on the swelling coffers of an almost immediate success. Within the first decade of business, Valentina's client list read like a who's who of blue-book society. With customers ranging from Park Avenue matrons to stars of the stage and silver screen, Valentina soon claimed Millicent Rogers, Lillian Gish, Gloria Swanson, Katharine Hepburn, Jennifer Jones, and even White House wives among her loyal following. Eleanor Lambert, the pioneer fashion publicist who represented Valentina for more than twenty-two years, claimed that Valentina was the dominant fashion designer of the 1930s and 1940s.

### **Designs for Stage and Screen**

From the early 1930s on, Valentina designed costumes for Broadway productions, operas, and (by the early 1940s) Hollywood films. Drawing on her experience in



theater, she was keenly aware of the character-specific, problem-solving needs of performers. Not surprisingly, Valentina's costume design quickly gained renown for helping to define a character's role without challenging an actor's stage presence. Aptly summing up Valentina's contribution to theater design, the drama critic Brooks Atkinson noted that "Valentina has designed clothes that act before ever a line is spoken." From Lily Pons to Rosa Ponselle to Gladys Swarthout, Valentina dressed and accessorized the world's most sought-after opera divas of the mid-twentieth century. Her stage and screen credits include longstanding working relations with Alfred Lunt and Lynn Fontanne, Norma Shearer, Paulette Goddard, Ginger Rogers, and Jennifer Jones, to name but a few. Her designs for and association with the reclusive film star Greta Garbo (who lived in the same Upper East Side apartment house as the Schlées) inspired endless sensationalistic journalism, but perhaps Valentina's most influential and highly publicized work was for Katharine Hepburn, whom she dressed in 1939 for Hepburn's starring role in the stage version of *The Philadelphia Story*. The white crepe, corselet-tied gown Hepburn wore was widely copied by designers at every price point across the nation for years.

In many ways, Valentina's work influenced fashion well beyond the scope of her limited elite clientele. In the 1940s, fashion editors coined the phrase "a poor-man's Valentina" to describe an affordable, simple, well-cut black dress devoid of any decoration. One of the first designers to promote monochromatic dressing, opaque and black stockings, and simple, short dresses for formal eveningwear, Valentina launched fashion trends that immediately trickled down to the masses. If Valentina's most recognizable calling card was simplicity, it should be remembered that hers was a carefully studied, highly disciplined simplicity. Her signature fragrance, "My Own," which was in production by the 1950s, was remembered by one ardent admirer as "Just like Valentina. Deceptively simple. But wildly complex." This carefully measured restraint during a time when floral appliqué, sequins, and pussycat bows were the ubiquitous choice of American dressmakers lent Valentina's designs a cool, modernist edge and earned her the respect and patronage of many of the most celebrated names in art, theater, and society. Wary of obvious fads and proudly declaring herself an American designer, Valentina insisted that true style and well-designed clothing were, in their ideal form, timeless, and she duly advised women to "Fit the century. Forget the year!"

In 1957, Valentina Gowns closed its doors—an event that coincided with the end of Valentina's marriage to George Schlée. The business was jointly owned and run, and it was George's role to manage the business while Valentina created—a two-person performance that simply could not be accomplished by Valentina on her own. In retrospect, however, it appears that Valentina's career might have run its course. By the late 1950s, both in the

press and on the streets, the sophisticated ladies of café society were reluctantly giving way to the youth-driven and fast-approaching 1960s, which would witness the imperious and haughty glamour of the preceding era slowly fading away like the lingering scent of a once ravishing perfume. From the very beginning of her career, up until her very last days, Valentina had remained at the very top of the most competitive, most exclusive, and perhaps least understood area of twentieth-century fashion history—American couture. She died in New York City in 1989 at the age of ninety.

*See also* **Film and Fashion; Hollywood Style; Theatrical Costume.**

#### BIBLIOGRAPHY

- Milbank, Caroline Rennolds. *New York Fashion: The Evolution of American Style*. New York: Harry N. Abrams, 1989.
- Steele, Valerie. *Women of Fashion: Twentieth-Century Designers*. New York: Rizzoli International, 1991.
- Watt, Melinda. *Valentina: American Couturiere*. Thesis New York University catalog holdings, n.d.

*Koble Yohannan*

**VALENTINO** Valentino Garavani (1932– ) was born in Voghera, a city in Lombardy, on 11 May. Even as a young man he was fascinated by fashion and decided to study design in Milan. When he was seventeen he discovered the extraordinary shade of red that would remain a design element throughout his career at a premiere of the Barcelona Opera.

#### Early Career

In 1950 Valentino went to Paris, where he studied design at the schools of the *Chambre Syndicale de la Couture Parisienne*. He obtained his first position as a designer with Jean Dessès. In 1957 Valentino went to work in Guy Laroche's new atelier, where he remained for two years. His training in France provided him with both technical skill and a sense of taste. In 1959 he decided to return to Italy and opened his own fashion house on the via Condotti in Rome with financial assistance from his family. In November he made his debut with his first couture collection, displaying 120 luxurious outfits notable for their stoles and draped panels that emphasized the shoulders. The *Sunday Times* of London was quick to take note of the new designer, singling him out for the refined lines of his tailoring and the sophistication of his garments.

In 1960 Valentino met Giancarlo Giammetti, who became his business administrator. At this time he moved his fashion house to via Gregoriana, 54. Valentino quickly became the favorite designer of the movie stars who were often found at Cinecittà, known as the new Hollywood during the years of Italy's economic boom. One of the first stars who wore Valentino's clothes was Elizabeth

Taylor, who was in Rome for the filming of *Cleopatra*. In 1960 Valentino signed an agreement with a British firm, Debenham and Freebody, to reproduce some of his couture designs. That same year he designed costumes for Monica Vitti in Michelangelo Antonioni's film *La Notte*. In 1963 Valentino's summer line was photographed on the set of Federico Fellini's film *8 1/2*.

Valentino's collection for fall–winter 1961–1962 featured twelve white outfits inspired by Jacqueline Kennedy. But what secured Valentino's fame was the success of his first fashion show on the runway of the Sala Bianca in the Palazzo Pitti in Florence in July 1962. For the first time French *Vogue* dedicated its cover to an Italian designer.

### International Success

Valentino's fall–winter collection for 1963–1964 was inspired by wild animals. American *Vogue* published a photograph of the contessa Consuelo Crespi wearing one of his zebra-patterned models, which anticipated his op art and pop art-inspired collection of spring–summer 1966. The 1966 collection has become famous for its prints and geometric designs, its stylized animals, and its large dots. That same year Valentino started a lingerie line and stunned his audience with a winter show that included pink and violet furs. Ethel Kennedy chose a Valentino dress for her meeting with Pope Paul VI in June 1966.

In 1967 Valentino received the Neiman Marcus Award in Dallas, which spurred him to further develop his creative ideas. The award was the direct impetus for his first men's collection, Valentino Uomo. The designer's accessories, especially his handbags with a gold "V," became essential items for the elegant women of the jet set. In 1968 Valentino introduced his famous Collezione Bianca, a spring–summer line of white and off-white garments that included suits, wraps, coats, and legwear in white lace. The show took place at a critical moment in international fashion and helped alleviate the crisis in haute couture—a crisis due to changes in international society in 1968 when people started looking at less exclusive models. In March of that year Valentino opened a store in Paris, followed by one in Milan in 1969. In October 1968 he designed Jacqueline Kennedy's dress for her wedding to Aristotle Onassis. He was the most acclaimed designer of the moment and expanded his circle of clients to include Paola di Liegi, Princess Margaret of England, Farah Diba, the Begum Aga Khan, Marella Agnelli, Princess Grace of Monaco, Sophia Loren, and many other well-known women.

Valentino lengthened hemlines and introduced folk and gypsy motifs in the early 1970s. He started his first boutique line in 1969. It was originally produced by Mendes, although ready-to-wear production was turned over to Gruppo Finanziario Tessile (GFT) in 1979. Valentino also opened a prêt-à-porter shop in the center of Rome in 1972. Throughout the 1970s his designs alternated between slender suits and harem pants coupled

with maxi coats. These designs often evoked a Liberty and art deco atmosphere, as in his 1973 collection inspired by the art of Gustav Klimt and the Ballets Russes. In 1974 he opened new stores in London, Paris, New York, and Tokyo (in the early 2000s there are twenty-five stores throughout the world). In 1976 he decided to show his boutique line in Paris, while keeping his couture line in Rome. Valentino launched his first perfume, named Valentino, in 1978. The following year he introduced a line of blue jeans at a famous discothèque, Studio 54 in New York City, which was publicized through an advertising campaign photographed by Bruce Weber.

The collections of the 1980s were characterized by sarong skirts gathered on the hip, draped garments, ruched fabrics, breathtaking necklines, and dramatic slits in a range of colors that emphasized the famous Valentino red, together with black and white. In 1982 the designer presented his fall–winter collection at the Metropolitan Museum of Art. In 1986 he introduced Oliver, a more youthful line named after his faithful dog, which he used as a logo. Three years later, Valentino decided to show his couture line in Paris, a series of garments inspired by ancient and modern art.

Valentino's collections of the 1990s integrated the themes of revival and self-reference—flounces, embroidery, and dots—partly as a way of emphasizing his thirty years in fashion, which were celebrated in several short films, exhibitions, and books. In January 1998, after a difficult period, Valentino sold his brand to the Holding di Partecipazioni Industriali SpA (HdP) group run by Maurizio Romiti, although Valentino remained the creative director. In 2002 HdP sold the fashion house to Gruppo Marzotto.

### Elements of Style

Valentino has paid his own personal tribute to contemporary fashion, inventing a recognizable look, modern yet sophisticated, which balances tradition and innovation through the image of an iconic femininity that is both classic and chic. Valentino's designs have as a common denominator the technical precision of fine tailoring, which he applies not so much for the sake of innovation but rather to provide a sense of stylistic continuity. Bows, ruching, and draping are distinctive features of many of his designs, together with the famous Valentino red. All these features are used strategically, serving to give the brand its mythic quality. Valentino's fabrics are printed with flowers, dots, and his own initial, which has doubled as a logo since the 1960s, highlighting the interplay between ornamental texture and effective communication.

A forceful interpreter of the lines and ambiance of the nineteenth century, with references ranging from the neoclassical with its fine drapery through the Second Empire with its crinolines, Valentino plays with the idea that his garments serve as a kind of aesthetic memory, a modern reference to a different time. Because of the designer's

ability to work with tradition, he has found a unique, although elitist, stylistic solution that has satisfied sophisticated women throughout the world.

See also **Celebrities; Italian Fashion; Vogue.**

#### BIBLIOGRAPHY

- Bianchino, Gloria, and Arturo Carlo Quintavalle. *Moda: Dalla fiaba al design*. Novara, Italy: De Agostini, 1989.
- Così, Marina. *Valentino che veste di nuovo*. Milan: Camunia Editrice, 1984.
- Morris, Bernadine. *Valentino*. Florence: Octavo, 1997.
- Pellé, Marie-Paule. *Valentino's Magic*. Milan: Leonardo Arte Editore, 1998.
- Sozzani, Franca. *Valentino's Red Book*. Milan: Rizzoli International, 2000.
- Valentino. *Trent'anni di magia. Le opere. Le immagini*. Milan: Bompiani Editore, 1991.

*Aurora Fiorentini*

**VEBLEN, THORSTEIN** A North American economist and sociologist, Thorstein Veblen (1857–1929) was an unrelenting critic of late nineteenth-century industrial society and in particular of the hierarchy of values asso-

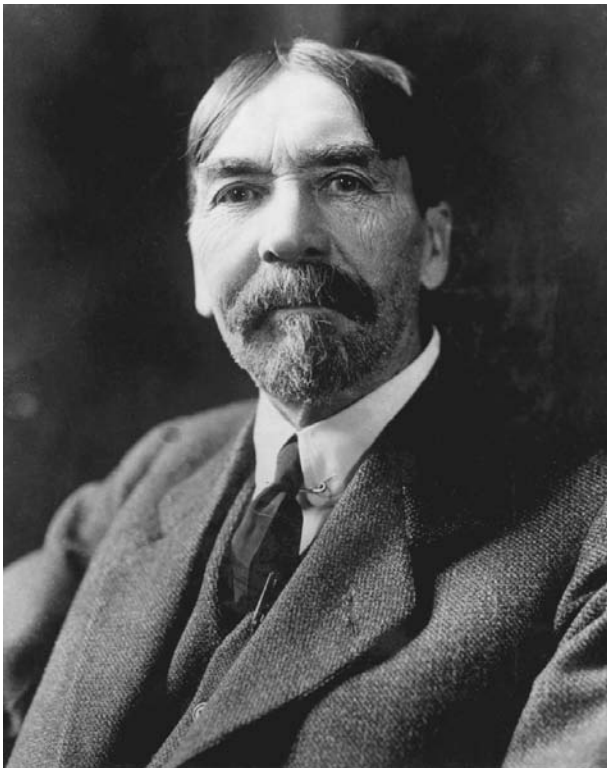

**Portrait of Thorstein B. Veblen.** In scrutinizing the leisure class, economist Veblen studied fashion trends and their relationship with the desire to display wealth. © BETTMANN/CORBIS. REPRODUCED BY PERMISSION.

ciated with its dominant group, which Veblen named the *leisure class*. Clothing and fashion, he argued, were important as a way in which this group competed among themselves for prestige and social status.

Veblen sought to understand the aims and ambitions of the leisure class by uncovering the economic motives that were at the center of their actions and values. In his classic text, *The Theory of the Leisure Class: An Economic Study in the Evolution of Institutions* (1899), he concluded that the economic activity of the leisure class is driven by a way of life given over to either the maintenance or the acquisition of “honorable repute.” The key to gaining status, argued Veblen, is for the households within the leisure class to dispose publicly of their wealth according to the principles of conspicuous consumption and conspicuous leisure. Adherence to these principles shows that a household and its members are able to consume without participating in the “demeaning and unworthy” activities attached to the “the industrial process.”

Although Veblen scrutinized a wide range of expenditures—including houses, food, gardens, and household pets—he singled out clothing for special consideration. As he observed, “no line of consumption affords a more apt illustration than expenditure on dress” (p. 123). This is because clothing is a social necessity and to be in public is, by necessity, to be clothed. By being on show, clothing becomes a prime indicator of its wearer’s “pecuniary repute” (p. 123), and since, in modern industrial society, clothing is a universal item of consumption, it is difficult for anyone to ignore the pressures of competitive emulation. Dress, therefore, is ideally placed as a vehicle with which to assert superior status in relation to one’s peers within the leisure class, as well as collectively displaying the superiority of this class over all others. Veblen concluded that dress has only a tentative connection to protection and bodily comfort, observing that “it is by no means an uncommon occurrence, in an inclement climate, for people to go ill clad in order to appear well dressed” (p. 124).

#### Dress and Conspicuous Consumption

Veblen argued that a prime function of dress within the leisure class is to display the wearer’s wealth by their consumption “of valuable goods in excess of what is required for physical comfort” (p. 125). According to Veblen the most immediate form of conspicuous consumption is *quantity*, or the possession of items of clothing (for instance shoes or suits) far beyond the requirements of reasonable daily wear. However, dress in the leisure class is also subject to considerations of *quality*. Ability to pay can also be demonstrated by the ownership of garments distinguished by the expensiveness of their materials, such as the goat hair used to weave pashmina shawls. Time-consuming methods of garment construction, and therefore expense, can, Veblen argued, insinuate itself into the esteem in which its wearer will be held. The comparison between a handmade garment and a machine-made one



is almost always in favor of the former. Finally, the *scarcity* of a garment can also be a factor in adding to the repute of its wearer. An original item from the studio of a famous designer, or a garment bearing the label of a chic fashion house, carries more prestige than an undistinguished item of clothing.

One final way that members of the leisure class exhibit pecuniary strength is always to appear in fashionable, up-to-date clothing. Veblen observed that “if each garment is permitted to serve for but a brief term, and if none of last season’s apparel is carried over and made further use of during the present season, the wasteful expenditure on dress is greatly increased” (p. 127).

### Conspicuous Leisure

Veblen’s exploration of the dress of the leisure class extends beyond the ways in which individuals consume items of clothing and engages with the very forms and styles assumed by these garments. As he wrote, “Dress must not only be conspicuously expensive; it must also be ‘inconvenient’” (p. 127). This is because, within the competitive logic of the leisure class, overt displays of wealth can be supplemented by wearing clothes that show the person in question “is not engaged in any kind of productive labour” (p. 125). Veblen uses this idea of conspicuous leisure to great effect in explaining the enormous differences in the form taken by men’s and women’s clothing at the end of the nineteenth century.

In scrutinizing contemporary men’s clothing for evidence of the principle of conspicuous leisure, Veblen argued that there should be an absence on the male garments of any evidence of manual labor such as stains, shiny elbows, or creasing. Rather, elegant men’s dress must exhibit signs that the wearer is a man of leisure. As he states, “Much of the charm that invests the patent-leather shoe, the stainless linen, the lustrous cylindrical hat, and the walking stick ... comes of their pointedly suggesting that the wearer cannot when so attired bear a hand in any employment that is directly and immediately of any human use” (p. 126).

The dress of the women of the leisure class, while embodying the salient principles of conspicuous consumption and conspicuous leisure, is also influenced by the inferior social position they occupy within the leisure-class household. It is the job of the woman, argued Veblen, “to consume for the [male] head of the household; and her apparel is contrived with this object in view” (p. 132). By wearing garments that are both expensive and inconvenient, such as ornate dresses, corsets, and complicated hats, women show that they do not need to work and so increase the “pecuniary repute” in which the head of the family is held. Veblen was one of the first modern thinkers to relate the appearance of women to their weak social and economic position.

Although Veblen’s analysis of dress and fashion has proved fruitful in social and historical contexts beyond

what he originally envisaged, he always considered his study to be an explanation applicable primarily to what took place within the leisure class, not as a universal theory of dress. Strongly influenced by Charles Darwin’s theory of evolution, Veblen believed that in the future men and women would progress beyond the restless changes of dress styles encouraged by “pecuniary culture.” In their place would emerge a set of relatively stable costumes similar to those Veblen imagined had existed in ancient Greece and Rome, China, and Japan.

See also **Fashion, Theories of; Fashion and Identity.**

### BIBLIOGRAPHY

- Bell, Quentin. *On Human Finery*. London: Hogarth Press, 1976. An extended interpretation of Veblen’s ideas on dress and fashion.
- Carter, Michael. *Fashion Classics from Carlyle to Barthes*. Oxford and New York: Berg, 2003. See chapter 3, “Thorstein Veblen’s Leisure Class.”
- Dorfman, Joseph. *Thorstein Veblen and His America*. New York: Viking Press, 1934. The standard biography of Veblen. Contains fascinating details of his personal taste in clothing.
- Riesman, David. *Thorstein Veblen: A Critical Interpretation*. New York and London: Charles Scribner’s Sons, 1953. See chapter 8 for a discussion of Veblen’s analysis of the corset.
- Veblen, Thorstein. “The Economic Theory of Women’s Dress.” In *Essays in Our Changing Order*. Edited by Leon Ardzrooni. New York: Viking Press, 1964. This is Veblen’s account of the historical and economic origins of women’s dress.
- . *The Theory of the Leisure Class*. New York: The Modern Library, Random House, 2001.

Michael Carter

**VEILS** *Veils, veiled, and veiling* emphasize different aspects of related “English” terms. As a noun, a veil is a piece of fabric draped as a head and upper or full body covering that functions as an item of dress. Whether an item of clothing or adornment, veils are physically used to cover and conceal, yet simultaneously draw attention to some visual aspect of the wearer. As a verb, “to veil” refers to the act of veiling or covering and concealing some visual or social aspect of the wearer, yet possibly, still inadvertently, revealing their identity. As an adjective, veiled, differentiates between the identity of the wearer who dons a veil or head covering or veils and covers and others who don’t in the a variety of social contexts.

Derivative terms for veils, veiled, and veiling and their meanings exist in other European languages such as in French (*voile*) and Latin (*vela* and *velum*). And elsewhere comparable terms are used for items of dress that function in a similar manner, that is, as a piece of fabric draped as a head and upper or full body covering, that covers and conceals, yet reveals the identity of the wearer



**Woman in wedding dress with veil.** In many religions such as Christianity and Judaism, veils are frequently worn as part of a bride's wedding ensemble. AP/WIDE WORLD PHOTOS. REPRODUCED BY PERMISSION.

and that differentiates between those individuals that choose to cover and those that do not.

### Historical Overview

The historical precedence for head coverings is vast, and references to veils, veiled, and veiling are complex. As El Guindi (1999) reviews, "veiling is a rich and nuanced phenomenon, a language that communicates social and cultural messages, a practice that has been present in tangible form since ancient times, a symbol ideologically fundamental to the Christian, and particularly, the Catholic, vision of womanhood and piety, and a vehicle for resistance in Islamic societies, and is currently the center of scholarly debate on gender and women in the Islamic east. In movements of Islamic activism, the veil occupies center stage as symbol of both identity and resistance."

Consequently, the use of the terms veils, veiled, and veiling and their comparables in other languages and cultures suggests many connotations. However, an understanding of the function and meaning of head coverings worn as veils is highly dependent on personal, social, and cultural perspectives. Frequently these views carry many

ethnocentric and misogynistic representations and interpretations. Regardless of the linguistic terms used, generalizations are generational and there exist gender associations, varied social contextual variables, and cultural differentiations in veils, and veiling practices. The following descriptive and interpretive examples provide some insights in the range of people who veil or cover and are veiled or covered and the customs and cultures that govern veiling and covering practices.

### Personal Identity

Historically, the terms *veils*, *veiled*, and *veiling* are associated with gendered and generational status. Though not the exclusive domain of women, as an article of dress, veils are associated with "being" female. They are typically draped fabric or head and/or body coverings that are generally the clothing or adornment form worn to differentiate female gender identity from males. Whether self-imposed or otherwise, customs associated with being female vary across cultures. For example, women in "western" cultures seldom wear veils while men rarely will wear them. In contrast, in the Middle East, men and women may frequently wear similarly draped garments that cover their heads, upper and lower bodies, but women may distinguish themselves by covering a portion of their face to conceal their identity in more public spaces. The *abaya* is one such example that is worn in many Arabic-speaking countries. Other examples, more culturally specific in historically Persian cultures are the *chador* worn in Iran and the *chaadar* worn in Afghanistan.

Age-related use of veils, veiled, and veiling practices across cultures frequently defines the transitions between stages of the female life cycle that reference physiological development and change as it relates to social status. One critical period is between youth and puberty. Veils, veiled, and veiling are often synonymous with the notion of symbolic space and specific rites of passage such as during puberty and coming of age ceremonies. Young Afghan girls begin wearing *chaadars*, veils, or head coverings to signal their change in status from a young nonmenstruating girl to a menstruating young woman, a young woman who is now of marriageable age. They may even wear them "prematurely" to appear more mature than their physiological development or chronological age.

The *dupatta* worn by Pakistani and Indian women also are gendered and generational examples of head coverings worn by young women on the Asian subcontinent. Few women would venture in public without one, and when traveling abroad the dupatta is still worn with either indigenous or local dress. The dupatta in these instances may be shawl- or scarf-like, a draped two-dimensional form.

Somali women wear a variety of head coverings or veils that differentiate the gender and age of the wearer. A *khaamar*, a scarf-like item, is worn singularly or in combination with a shawl-like garment or *gaarbo saar*. A more religious head covering is *hijab*, and the most religious

form is the *nikaab*, which completely conceals the entire face except for the eyes.

In direct contrast to Arab custom, Tuareg men from Algeria, rather than women, wear veils. However, they often leave their face uncovered when they travel or are with their family.

### Social Constructions

In addition to personal statements of gender and generational identity found geographically, closely linked social constructions are nearly inseparable from familial and marital status, geographic location, religious affiliation, memberships, and special associations.

Wearing a veil and following local customs that govern female space in both the domestic and public environment may express familial status as well as female position within a family. In a Gujarati village in India, veils, or *saddo*, are worn, and the custom of veiling or *ghughut* is practiced. As Tarlo describes, “ghughut is a form of deference and respect performed by women largely to men” (1997; 160). The local term for many variations of veiling is *laj* or “doing shame.” Laj variations, the way and degree in which the face, head, and body are covered, communicate a female’s relationship to the males in the family but also the status of the family in the community.

Veils, veiled, and veiling may also suggest a change in marital status. During a Christian wedding ceremony a bride wears a veil. The bride’s father “gives her away” wearing a veil that covers her face as part of her bridal ensemble. The bride and groom recite vows then the groom uncovers the bride’s face. Also at times of death, widows, in the nineteenth and early twentieth century wore a black shroud, veils or head coverings, that covered their face, and honored a deceased husband.

In a Jewish marriage ceremony, the tradition of veiling the bride is traced back to the reference to Rebecca in Genesis “Rebecca took her veil and covered herself” upon first meeting Isaac. Popular legend attributes the custom to the Biblical story of Jacob and his wives. After working for seven years for permission to marry Rachel, Jacob was tricked on his wedding day into marrying Leah, Rachel’s sister (she was wearing a veil) instead. To avoid such a mishap, according to legend, the groom “checks” to be sure that it is, indeed, his bride, before her veil is lowered over her face.

These examples of familial and marital status portray veils and veiling practices as a means to control personal symbolic space such as modesty or *haya*—an Arabic term that encompasses many concepts, including self-respect and scruples, in addition to modesty. This is especially evident in faith-based markers of female identity. For example, during calls to prayer, Muslim women wear hijab, head and upper body coverings, as they pray either in the private domestic sphere or when praying in more public, yet segregated, mosque settings. In contrast, dur-

ing confirmation ceremonies, young Christian girls dress modestly wearing white veils expressing their purity as they recite their acceptance of faith in church. In a similar fashion, religious women or nuns have worn various styles of veils or head coverings as part of their ensemble or habit, communicating purity, modesty, and devotion.

Veils, veiled, and veiling may also convey the geographic differences of the wearer. Traditionally, though not exclusive to Middle Eastern and Eastern cultures, urban and rural differences were evident in the use of veils, veiled, and veiling practices. In rural areas veils, veiled, and veiling were less evident among known kin groups but as travel permitted, women in more urban settings tended to veil, cover, and conceal themselves wearing *chaadarees* or *burqas* to “protect” themselves, their virtue, modesty, and purity, and their families from unknown or unrelated males (Daly 2000).

Socioeconomic distinctions highlight the aesthetic choices of veils, veiled, and veiling practices. The Pakistani woman’s dupatta elaborately decorated with beads, sequins, and embroidery is a sign of social status, wealth, and prestige when worn.

### Contemporary Examples

Early twenty-first century examples of veils, veiled, and veiling practices focus on Muslim women and their appearance. Throughout the twentieth century, veils, veiled, and veiling practices vacillated between issues resulting from personal, social, and cultural constructions of identity. Several examples are worth noting because of reform movements and the politicization of gender, religion, and nationality. At the beginning of the twentieth century, political leaders in Turkey and Afghanistan struggled to define women’s national identity through control of their appearance in public contexts. Conservative leaders struggled to maintain customary practices that reinforced Islamic Sharia codes of conduct, while other progressive leaders initiated political reforms that not only permitted, but also encouraged Muslim women to eliminate head coverings as a sign of modernity. For the duration of the century and with each new regime, religious and political leaders alike revisited “the woman question.”

By the end of the twentieth century, veils, veiled, and veiling practices resurfaced as a source of contention in the geopolitical and national realm. Now the woman question became aligned with sophisticated discrimination and human rights issues in diaspora immigrant communities where Muslim women live and also in their countries of origin. In addition, Islamists fought for women’s inability to choose, while feminists fought for the same women’s ability to choose whether or not to wear a veil. The Taliban in Afghanistan became the most strident example of female control, forcing both Islamic and Pushtunwali strict codes of conduct regardless of religious affiliation. In the United States, female Muslim



refugees struggled to maintain gender, religious, and national head covering practices in the wake of anti-Islamic dress codes. Other countries such as France, Iran, and Pakistan lobbied to self define their own head and body covering practices.

See also **Burqa; Chador; Hijab; Wedding Costume.**

#### BIBLIOGRAPHY

- Arthur, Linda, ed. *Religion, Dress and the Body*. Oxford: Berg, 1999.
- . *Undressing Religion: Commitment and Conversion from a Cross-Cultural Perspective*. Oxford: Berg, 2000.
- Bailey, David A., and Gilane Tawadros, eds. *Veil, Veiling, Representation and Contemporary Art*. Cambridge, Mass.: The MIT Press, 2003.
- Daly, M. Catherine. "The Paarda Expression of Hejaab among Afghan Women in a Non-Muslim Community." In *Religion, Dress, and the Body*. Edited by Linda Arthur. Oxford: Berg, 1999.
- . "The Afghan Woman's Chaadaree: An Evocative Religious Expression?" In *Undressing Religion: Commitment and Conversion from a Cross-Cultural Perspective*. Edited by Linda Arthur. Oxford: Berg, 2000.
- El Guindi, Fadwa. *Veil: Modesty, Privacy and Resistance*. Oxford: Berg, 1999.
- Lindisfarne-Tapper, Nancy and Bruce Ingham, eds. *Languages of Dress in the Middle East*. Surrey: Curzon Press, 1997.
- Shirazi, Fegheh. *The Veil Unveiled: The Hijab in Modern Culture*. Gainesville: University Press of Florida, 2001.
- Stimpfl, Joseph. "Veiling and Unveiling: Reconstructing Malay Female Identity in Singapore." In *Undressing Religion: Commitment and Conversion from a Cross-Cultural Perspective*. Edited by Linda Arthur. Oxford: Berg, 2000.
- Tarlo, Emma. *Clothing Matters: Dress and Identity in India*. Chicago: University of Chicago Press, 1996.

M. Catherine Daly

**VELCRO.** See **Closures, Hook-and-Loop.**

**VELVET** Velvet is a pile fabric in which an extra warp (lengthwise) yarn creates a raised uncut loop or cut tuft on the fabric surface. Velvet is first encountered in low, uncut pile examples in Chinese silk *qirong jin* or *rongquan jin* that date to Warring States (403–221 B.C.E.), Qin (221–206 B.C.E.), and Western Han (206 B.C.E.–23 C.E.) dynasties. More consistent with velvet's allure of tactile seductiveness are the resplendent, late-medieval cut-pile velvets of Italy and Spain made possible by the rapid development of draw loom technology supported by discerning patrons. Parallel achievements were seen in Ottoman Turkey, Persia, and later in Mughal India.

The prodigious repeat sizes and lavish use of precious materials—fine and dense silk, and, for the most sumptuous versions, added gilt-silver wefts (yarn running

crosswise) worked flat or in loops—are pervasive in fifteenth-century European depictions portraying sacred and secular elites dressed in vestments, gowns, and mantles of giant, serpentine pomegranate and artichoke designs. The velvets of Bursa and Istanbul made for fifteenth-century caftans, cushions, and tent panels for the sultans display similar splendor. In Persia, by contrast, where cut velvet seems to have originated, the long reign of the Safavid dynasty favored narrative designs of hunt scenes and literary genre figures, the rich coloristic effects made possible by intricate pile-warp substitutions.

The European capital-intensive velvet industry was closely allied with merchant banks and the courts, and flourished first in Italy (Florence, Genoa, Venice, and Milan), then elsewhere, particularly in France (Tours, and above all Lyon). Closely controlled velvet qualities developed, and were assigned dozens of specialized French terms to distinguish the types—some are still current. They ranged from plain velvets, sometimes given added value by stamped designs and other finishes, to patterned ones by varying pile heights and introducing two or more pile warp colors.

In the early modern period, wealthy patrons continued commissioning large-scale custom designs for special occasion outfits, while stock styles of smaller repeat patterns were used in standard dress velvets. A number of them were woven for Western customers in China, where interest in the structure had reawakened, and spread to Japan. Great numbers of these small-scale designs survive in art and textile fragments and show floral sprig, bird, and animal motifs subordinated into lattice-type patterns.

From the middle of the eighteenth century and into the next, silk velvet appeared in men's apparel (especially waistcoats) and luxury carriage interiors, but women's fashion abandoned stately velvet in favor of lighter fabrics. Through the nineteenth century, Lyon in particular, produced elaborate, fine velvets woven by hand on Jacquard looms, designed to win prizes at world fairs, and promoted in fashions of the emerging Parisian couture houses.

Plain, patterned, and printed silk velvets and the longer-piled relation, plush, were featured in glamorous opera coats during the early twentieth century. Cotton and rayon frequently substituted for scarce and expensive silk, and most plain velvets are now woven double on power looms, creating two fabrics sharing a pile warp, subsequently separated by horizontal cutting blades. In the late twentieth century, China exported quantities of inexpensive silk velvets, and innovative textile designers eagerly applied new looks with earlier methods, such as burn-out and resist dyeing for fashion accessories.

See also **China: History of Dress.**

#### BIBLIOGRAPHY

- Becker, John. *Pattern and Loom: A Practical Study of the Development of Weaving Techniques in China, Western Asia and*

*Europe*. Copenhagen: Rhodos International Publishers, 1987. Meticulous descriptions of early textile structures and their possible loom technologies.

Burnham, Harold B. *Chinese Velvets: A Technical Study*. Occasional Papers 2. Art and Archeological Division, Royal Ontario Museum. Toronto: University of Toronto Press, 1959. An in-depth analysis of seventeenth-century velvets of East Asia.

Fauque, Claude, ed. *Le Velours ou la force de la douceur*. Paris: Syros, 1994. A cross-disciplinary survey touching on history, technology, ideologies and design that includes, in the French understanding of the term *velours*, weft-pile structures as well.

Geijer, Agnes. *A History of Textile Art: A Selective Account*. London: Pasold Research Fund, 1979. The indispensable reference for historic textiles, their trade, cultural exchanges, and context.

Hardoiun-Fugier, Elisabet, Bernard Berthod, and Martine Chevent-Fusaro, eds. *Les ftoffes: Dictionnaire historique*. Paris: Les editions de l'Amateur, 1994. Richly illustrated reference work, with comprehensive listings of velvet terms.

*History of Textile Technology of Ancient China*. New York: Science Press, 1992. Fundamental text on Chinese textiles and their materials although technical terms are at times at variance with Western accepted standards.

Janssen, Elsje. *Richesse de Velours*. Brussels: Musee du Cinquante-naire, 1995. An exhibition catalog covering early examples to contemporary Belgian velvets.

King, Monique and Donald King. *European textiles in the Keir Collection 400 B.C. to 1800 A.D.* London and Boston: Faber and Faber, 1990. A catalog establishing important developments in design and interactions between cultures.

Mackie, Louise. *The Splendor of Turkish Weaving: An Exhibition of Silks and Carpets of the 13 Centuries*. Washington, D.C.: The Textile Museum, 1973. A fine hand list of the TMO's Turkish velvets.

Santangelo, Antonino. *A Treasury of Great Italian Textiles*. New York: Harry N. Abrams, 1964. A still useful standard in the literature on textiles.

Sunday, Milton. "Pattern and Weaves: Safavid Lampas and Velvet." In *Woven from the Soul, Spun from the Heart: Textile Arts of Safavid and Qajar Iran 16th–19th Centuries*. Edited by Carol Bier. Washington, D.C.: The Textile Museum, 1987. Detailed structural study and diagrams of Persian velvets.

Stack, Lotus. *The Pile Thread: Carpets, Velvets, and Variations*. Minneapolis: The Minneapolis Institute of Art, 1991. A succinct and comprehensive guide, with good illustrations of the technology, design, and context of velvet.

*Désirée Koslin*

**VELVETEEN.** See **Weave, Double; Weave, Pile.**

**VERSACE, GIANNI AND DONATELLA** Gianni Versace (1946–1997) was a defining figure in the world of design in the 1980s and 1990s. He dressed the inde-



**Gianni Versace, with models Claudia Schiffer and Naomi Campbell.** In the 1980s and 1990s, designer Gianni Versace dressed celebrities in his well-renowned, daring, and bold fashions. AP/WIDE WORLD PHOTOS. REPRODUCED BY PERMISSION.

pendent spirits, celebrities, and the rich, young, and fearless. His exclusive clique personified his ideals of men's and women's ready-to-wear and couture clothing. He also created accessories, linens, and a collection for the home inspired by his preference for the baroque style. Versace's knowledge was encyclopedic and his sense of history prophetic; his genius was the successful linkage of fashion and culture.

Following Versace's tragic death in July 1997, his sister Donatella was catapulted into the international limelight. Only three months later, no longer her brother's muse and collaborator, she assumed creative direction over the development of a dozen highly demanding collections. An earlier agreement between brother and sister had established that she would be the one to carry on his work if it were ever necessary. As a result the signature Versace Atelier collection was presented as usual in Paris in 1998.

Donatella Versace was born in Reggio Calabria, in southern Italy in 1955. She was one of four children born to a businessman and an accomplished seamstress. During Donatella's childhood, Gianni designed clothing for his younger sister, who became the embodiment of his

standards. After she completed her studies in Italian literature at the Università di Firenze to supplement her sense of culture, she followed Gianni to Milan, where he had established his career. Initially he sketched his first ready-to-wear collections for the manufacturing firms of Genny, Complice, and Callaghan.

Donatella arrived with the intention of shaping her brother's public image through deft management of his public relations. When he established his signature company in 1978, she became his spirited muse-in-residence. Santo Versace, an older sibling, assisted in the organization of the business, which he continues to direct.

As the house's driving creative force since 1997, Donatella has forged on to energize her international team of fashion designers. Her entrance-making gowns, as well as practical, elegant ready-to-wear clothes and men's wear maintained a high profile in her design studios and corporate offices in the center of Milan. The Versace family estates are located in nearby Como, within an hour's drive from the Milan corporate headquarters.

### Business Innovations

Donatella's larger-than-life approach to creating fashion mirrored her brother's maxim that fashion must fuse with the media, the performing arts, celebrity, vitality, and sexuality. Donatella staged the audacious, high-powered Versace runway shows after Gianni's death, enlisting the friendship and devotion of many of the supermodels. Her brother had initiated successful advertising campaigns with photographers and artists beginning in the late 1970s: Richard Avedon and Andy Warhol, among others, shared his flamboyant taste for self-promotion. Donatella continued in this vein, preferring to work with such photographers as Steven Meisel and Bruce Weber. The company continued to unleash dynamic, sexually charged media campaigns in the early 2000s as it expanded its share of the luxury trades.

Gianni Versace's penchant for extreme styling and unconventional choices of sumptuous and radiant fabrics combined themes from his studies in art history with new technology. The Versace label was more focused on the modern career woman in the early twenty-first century, a change reflected in the variety of garments it produced. Donatella's hallmarks included flashy materials fluidly draped. She presented herself on the international stage as the model of an invincible woman. Donatella also launched the fragrance Versace Woman in 2001.

### Personal Image

During their adolescence and early adult years, brother and sister remained loyal to each other. Gianni created vibrant garments for Donatella that embodied his personal rationale of expression. The freedom to dare, to make personal choices, was one of the Versace duo's resonant manifestos. During their nineteen years of collaboration, Versace consulted his younger sibling in all important decisions. Her bravura and dedication made

her an integral part of the company as it developed. In early 2000 she epitomized the liberation he sought as a designer. Gianni paid tribute to Donatella when he named his 1995 perfume Blonde to honor her trademark long, platinum locks. Surrounded by revelers, her frequent tours of nightspots provided her with access to the younger generation. In due course, Donatella became chief designer for Versace's Versus collection, where she further empowered her success with their dual vision of bold patterns and high glamour infused with sex appeal, designed for a younger clientele. While Donatella was independent in her thinking, she was also committed to her brother's enduring legacy. She continued to style flashy and extreme ready-to-wear clothing as well as a couture line, as she did during her apprenticeship with Gianni and in her position as an accessory designer and creator of a line of children's clothing in 1993.

Donatella's camaraderie with celebrities, including Elton John, Elizabeth Hurley, and Courtney Love, reflected her belief in the significance of uncompromising friendships. Madonna, Jon Bon Jovi, Sting, and Trudy Sklyer were among her closest confidantes. Like her older brother, she combined music with the media and the spectacle of contemporary urban life. Donatella's designs affirmed sensuality, employing short skirts and plunging necklines as devices of freedom. "Fashion can be freedom or it can be a way to live with no freedom," she avowed in *Interview*.

Donatella married the former model Paul Beck, with whom she had two children—Allegra, her uncle's beneficiary, born in 1986, and Daniel, born in 1991.

Donatella Versace reveled in the attention she received in fashion and popular lifestyle magazines. She pursued visibility at all levels of society and was always ready to convey the glamorous extravagance that identified her company. Her fashion edicts remained consistent: "If I want to be blonde, I am not going to be a medium blonde. I am going to be totally blonde. If I am going to wear heels, they are not going to be two inches high. They are going to be much higher than that. It's the freedom of extremes that I love" (*Interview*). Her confident design ethic mirrored that of her late brother, who became a creative genius in high-end apparel and of bold gestures in the media.

*See also* Avedon, Richard; Celebrities; Fashion Photography; Italian Fashion; Madonna; Meisel, Steven; Supermodels.

### BIBLIOGRAPHY

- "Friendship is Freedom." *Interview* 30, no. 3 (March 2000): 212.
- Martin, Richard. *Versace*. New York: Universe/Vendome, 1997.
- . *Gianni Versace*. New York: The Metropolitan Museum of Art and Harry N. Abrams, Inc., 1998.
- Spindler, Amy M. "Style: The Great Gianni." *New York Times* (18 February 2001).

*Gillian Carrara*



**VICTORIAN FASHION.** See Europe and America: History of Dress (400–1900 C.E.).

**VICUNA.** See Alpaca.

**VIKTOR & ROLF** The Dutch saying, *Doe normaal, dan ben je al gek genoeg* (literally, Just be normal, then you are crazy enough) sheds light on the work of design team Viktor & Rolf. Viktor Horsting (b. 1969) and Rolf Snoeren (b. 1969) met while they were students at the Arnhem Academy of Art, the Netherlands, in 1988. They both sought to escape the boredom they experienced while growing up in small, quiet, suburban towns in southern Holland. “We had nothing to relate to, never saw glamour except for fashion magazines, and longed to escape to those dream worlds,” Horsting once said to an interviewer. By pushing the boundaries of what defines fashion, Viktor & Rolf inspired a new generation of Dutch fashion designers and helped to expose the international fashion media to a country known more for wooden clogs than high fashion.

Viktor & Rolf are characterized in Stephen Gan’s *Visionaire 2000* (1997) as “fashion’s biggest fans and its toughest critics.” While their works celebrate the detailed craftsmanship of tailoring and consistently reference classic silhouettes from the legendary couturiers Cristóbal Balenciaga, Coco Chanel, Christian Dior, and Yves Saint Laurent, they also critique the twentieth- and twenty-first century’s fashion industry, tackle the stereotypes of fashion, and expose its vulnerabilities to a runway audience.

### The Early Experiments

Viktor & Rolf’s first collection won the grand prize at the *Salon européen des jeunes stylistes* (1993), a fashion festival in the southern French city of Hyères. When deconstruction was the trend, Viktor & Rolf reconstructed by piling layers of men’s button-down shirts to form ball gowns. The following year they suspended flashy gold garments adorned with oversized ribbons and excessive decorations from the ceiling in their installation *L’Apparence du vide* (1994) at the Galerie Patricia Dorfman, Paris, which sought to critique the aura and hype surrounding fashion. In another experiment, sleek marketing for *Viktor & Rolf, le parfum* (1996) served to critique the superficial, banal beauty of fragrance advertising. The neatly packaged, limited-edition (2,500) perfume bottles were deliberately designed so that they could not be opened. The bottles sold out at the Parisian boutique *Colette*. In *Launch* (1996), presented at the Torch Gallery in Amsterdam, Viktor & Rolf’s dream world of the fashion process was realized on a small scale. They explained that, with a doll-sized runway, sketch and draping session, and photo shoot setup, “we created the ultimate goals we wanted to achieve in fashion (but felt unable to). These miniatures represented some of the most emblematic situations in fashion we wanted to become re-



**Viktor Horsting (left) and Rolf Snoeren.** The Dutch fashion duo are well known for their innovative, unusual clothing designs and inventive runway performances. MARTIN BUREAU/AFP/Getty IMAGES. REPRODUCED BY PERMISSION.

ality” (Personal interview, 23 December 1999). Their dream was realized soon thereafter in the form of an haute couture collection.

### The Haute Couture Collections

Viktor & Rolf brought an intellectual approach to the fashion process via art. They pursued haute couture because they found it to be “the most sublime” aspect of fashion. With Dutch government support and the Groninger Museum, the Netherlands, as their sole client, Viktor & Rolf were able to develop creatively without the pressure of maintaining profitability that most young designers experience. In their second spring/summer 1998 collection at the Thaddeus Ropac Gallery in Paris, Viktor & Rolf created their signature “atomic bomb silhouette”—exaggerated on top and pencil-skinny on the bottom. The clothes were dedicated to the millennium (fit either for the biggest celebration ever or apocalyptic destruction) and were deformed with silk balloons, streamers, and other brightly colored party elements. The Viktor & Rolf label was recognized by the Fédération de la couture, the umbrella organization that oversees the Parisian haute couture houses and their events. This prestigious invitation for inclusion occurred even though Viktor & Rolf did not conform to the organization’s rules and guidelines. Viktor & Rolf presented their entire fall/winter 1999–2000 collection on the shoulders of one model, Maggie Rizer. As she stood on a revolving platform, Viktor & Rolf layered, in nine successive stages à la Russian-doll style, precisely-engineered jute dresses decorated with Swarovski crystals. Through this mechanism they attempted to showcase their feelings about haute couture as a precious and unattainable jewel.



**A model poses in an outfit by Viktor and Rolf.** Critical of the twentieth- and twenty-first century's fashion industry, Dutch designers Viktor Horsting and Rolf Snoeren tackle the stereotypes of fashion. © REUTERS/CORBIS. REPRODUCED BY PERMISSION.

### Viktor & Rolf in the Twenty-first Century

The fashion media's attraction to their exaggerated silhouettes and noteworthy runway performances has always played an integral role in the shaping of the Viktor & Rolf brand identity. With no advertising campaigns, no self-standing boutiques, and no mass-produced clothes to sell, their early relationship with the public depended heavily on the generous amounts of press coverage they received each season. (Close collaborations with photography teams Inez van Lamsweerde and Vinoodh Matadin, as well as Anouschka Blommers and Niels Schumm, also helped further their vision.) The media's acknowledgment of Viktor & Rolf as a leading avant-garde haute couture label was instrumental to the commercial success of their ready-to-wear line. Their first collection sold immediately to sixty stores worldwide during its launch in February 2000.

Viktor Horsting and Rolf Snoeren understand that a fashion designer's public image is nearly as important as the clothes that are created. Oftentimes referred to as "the Gilbert & George of fashion," the two present themselves as mirror images of each other: matching dark-

rimed glasses, closely trimmed dark hair, and a serious demeanor despite the humor in their shows. They performed a tap-dance finale with tuxedos, top hats, and canes to "Putting on the Ritz" and "Singin' in the Rain" for their spring/summer 2001 collection. Additionally, they used themselves as models for the launch of their fall/winter 2003–2004 men's wear collection, *Monsieur*, as they synchronized changes into looks depicting clichés of traditional men's wear.

Viktor & Rolf continue to push the boundaries of fashion in ready-to-wear by using the catwalk as a stage for performance art. Models were cast as walking shadows, for example, in their "Black Hole" collection (fall/winter 2001–2002) when they were covered head-to-toe in black silhouettes and black makeup. Two years later (fall/winter 2003–2004) their models appeared as fair-skinned, red-haired clones of the actress Tilda Swinton.

Through their shows Viktor & Rolf try to bring fantasy, beauty, and magic back to fashion as they forge a path for the viewer to enter their dream. "For us," explains Rolf Snoeren, "it's always about escaping reality, so in that sense the clothes are meant to show beauty first. Beauty and hope. Because cynicism, you know, kills everything."

See also **Fashion Designer**; **Fashion Shows**.

### BIBLIOGRAPHY

- Alonso, Roman, and Lisa Eisner. "Double Dutch." *New York Times* (8 December 2002): 109. This in-depth interview reveals the personalities and fantasy worlds of Horsting and Snoeren.
- Horsting, Viktor, and Artimo. *Viktor & Rolf*. Breda, Netherlands: Artimo Foundation, 1999. This artist's book covers Viktor & Rolf's early work, 1993–1999.
- Lowthorpe, Rebecca. "The Gilbert & George of Fashion." *The Independent on Sunday* (30 September 2001): 35–38.
- Martin, Richard. "A Note: Art & Fashion, Viktor & Rolf." *Fashion Theory: The Journal of Dress, Body & Culture* 3 (1999). Martin analyzes Viktor & Rolf's early works and emphasizes their importance in crossing the boundaries of fashion with art.
- Spindler, Amy. *Viktor & Rolf Haute Couture Book*. Groningen, Netherlands: Groninger Museum, 2001. A retrospective exhibition catalog featuring the haute couture collections at the Groninger Museum.

*Angel Chang*

**VINTAGE FASHION** The trend for "vintage" clothing as fashion exploded in the 1960s. Prior to this, the trading and wearing of old clothing had different connotations. All levels of trade in old clothing were well supported by the increasing speed of fashion change from the fifteenth and sixteenth centuries, and the growth in consumer availability of these trends. As the commercial constituency for fashion increased, the growth in trade of old clothing was incremental as the quantity

of these goods increased. The original ragpickers collected items that others had disposed of and returned them back to the economic cycle. Consequently, the ragpicker was allied with other outsiders, or members of the underclass. Karl Marx was later to define the philosophy of artistic bohemianism by its links to this social underclass. Bohemians, he believed, were vagabonds whose position was characterized by economic necessity *or* (crucially) romantic interpretation. This ambivalence between necessity and choice is essential to an understanding of vintage clothing.

The link between fashion and old clothing made the clothing a definitive indication of one's social status—the line and fabric of a jacket from a period too recent to be fashionable *or* classic immediately indicated that the wearer was drawn from the lower classes. It was a stigma that people were painfully aware of. The ethos of “make-do-and-mend” allowed the lower classes to position the wearing of old clothing as thrifty and, during wartime, patriotic. However, it was very specifically old clothing that was passed down through families. It was, most certainly, rarely purchased. Consumers of old clothing were, then, considered to be those seeking to give an impression of higher social status, the destitute, or actors, and consequently were treated, in some ways, as suspiciously as those who sold them the garments.

Prior to the mid-1960s old clothing had not been widely positioned within traditional retailing environments, its traders preferring the market stall, auction, or pawnbrokers as a venue for selling. The retailing of old clothing has been viewed in diametrically opposed lights—as a criminal activity for laundering money, as good business practice, and, from the advent of charity shops, as an altruistic pastime. Most cities in the United Kingdom had large warehouses that distributed second-hand clothes, and despite the falloff in trade in the late twentieth century, many still have significant export markets. As trade in old clothing fell, the practice of wearing old clothing rose and became known as “vintage,” moving from the market place to the upper market boutique.

In London, dress has been persistently retailed as vintage since the early 1970s. Shopping guides of the mid-1970s note numerous vintage retailers, some offering in-house tailoring with vintage fabric, predating in practice (although quite possibly not in philosophy) the work of designers such as Martin Margiela, Russell Sage, Alice Temperley and Jessica Ogden. However, it was still not considered a wholly acceptable practice, and the clothing was predominantly worn by consumers affecting a rebellious challenge to the mores and propriety of previous generations.

The duality between thrift and economy on the one hand, and subversive practice on the other, made vintage fertile as a signifier for bohemian morality and practice, notably in the 1950s and 1960s. The hippie lifestyle was positioned as anticonsumerist, which sartorially was com-

municated through the wearing of old clothes. This interpretation continued throughout the following decades, as seen in the political stance of the Women's Environmental Network in the 1990s, but also in the work of designers such as Helen Storey, Komodo, and to a degree, Vivienne Westwood and the Punk movement.

The twenty-first century trend for vintage clothing has its roots more specifically in bohemianism—in the performance of individuality and artistic (rather than aristocratic) elitism. A number of specialist boutique retailers in London have acquired significant profile and status. A number of these (Virginia, Sheila Cook, Steinberg and Tolkein) are regularly credited and quoted in fashion magazines, and a steady flow of celebrities list them in “my favorite store/best-kept secret” questionnaires in Sunday supplements. Across Europe and North America, vintage retailers are no less conspicuous for their domination of fashion headlines. The owners of Resurrection and Mayle (New York) and Decades and Lily (Los Angeles), are considered important “women of fashion” and costumers to the stars. The vintage revival in the United States is due, in no small part, to the eclectic image that stylist and vintage retailer Patricia Fields created for Sarah Jessica Parker's character Carrie in the HBO comedy *Sex and the City*.

Retailers such as Selfridges, TopShop, and Jigsaw in London, A.P.C. in France, and Barneys and Henri Bendel in New York have all picked up on the trend, incorporating vintage offers or vintage-inspired collections into their ranges. Wearing vintage has become a distinguishing marker of cultural and economic capital—it's unique, it's expensive, and so on—that privileges the individual. More than money, it is free time that is required to invest in the laborious process of seeking, finding, repairing, and selling old clothing. In the latter half of the twentieth century and beyond, that free time was available predominantly to those who were wealthy or who were engaged in work that was flexible—principally, therefore, creative. Because the vintage garment is unique, it also suggests that the wearer is individual, separate from the increasingly and obviously shallow process of fashion.

Interestingly, many Hollywood celebrities have embraced vintage principally because it is outside fashion—suggestive either of anticonsumerist philosophy or of individual choice. Actresses allied with independent cinema such as Chloë Sevigny appear to have adopted the “trash” aesthetic to distinguish themselves from mainstream fashion. Sevigny's protégé designers Imitation of Christ are proponents of an anticorporate philosophy not dissimilar to Westwood's in the early 1970s. On the other hand, Nicole Kidman, one of the most prominent wearers of vintage in contemporary Hollywood, tends to purchase from retailers who position their stock as antique—timeless and culturally valuable—highlighting her sense of personal, individual style, which is supposedly sincere, authentic, and equally as timeless as the clothing she prefers.



One of the most pointed criticisms of vintage is that it is detrimentally nostalgic, particularly in its influence over contemporary design. Alongside the retailers, a cluster of designers have been steadily drawn toward old clothing, either literally, in the reworking of found fabrics or garments, or indirectly, in their plunder of the annals of dress history to create a modernized antiquity for the post-modern consumer. Designers as diverse as Ralph Lauren, John Galliano, Alexander McQueen, Donna Karan, and Miuccia Prada are all known to have invested heavily in vintage clothing to use as resource material. However, it is not necessarily a nostalgic practice since the selection of pieces is informed by the contemporary. Crucially, it is not necessarily the garment itself, but its positioning in a contemporary debate and context that reinvigorates the memories and meanings the garment contains.

See also **Actors and Actresses, Impact on Fashion; Bohemian Dress; Secondhand Clothes, Anthropology of.**

#### BIBLIOGRAPHY

- Benjamin, Walter, trans. *Arcades Project*. Cambridge, Mass.: Belknap Press of Harvard University Press, 1999.
- Bourdieu, Pierre. *Distinction: A Social Critique of the Judgement of Taste*. London: Routledge and Kegan Paul, 1984.
- Cicolini, Alice. "Vielle Couture: Authentic Display." Master's thesis. London College of Fashion, 2002.
- Dyer, Richard. *Stars*. London: BFI Publishing, 1998.
- Ewen, Stuart. "Varnished Barbarism." In *All Consuming Images: The Politics of Style in Contemporary Culture*. New York: Basic Books, 1988.
- Ginsburg, Madeleine. "Rags to Riches: The Second-Hand Clothes Trade, 1700–1978." In vol. 14 of *Costume*. London: V&A Publishing for the Costume Society, 1980.
- Joliffe, Kira. *Cheap Date: Antidotal Anti-Fashion*. Hove, U.K.: Slab-O-Concrete Publications, 2000.
- Jones, Ann R., and P. Stallybrass. *Renaissance Clothing and the Materials of Memory*. Cambridge U.K.: Cambridge University Press, 2000.
- Lemire, Beverly. *Dress, Culture, and Commerce: The English Clothing Trade before the Factory, 1660–1800*. London: Macmillan, 1997.
- Silverman, Kaja. "Fragments of a Fashionable Discourse." In *Studies in Entertainment: Critical Approaches to Mass Culture*. Edited by Tania Modleski. Bloomington and Indianapolis: Indiana University Press, 1986.
- Tolkein, Tracy. *Vintage: The Art of Dressing Up*. London: Pavilion, 2000.

Alice Cicolini

**VINYL AS FASHION FABRIC** Vinyl is a plasticized variation of Polyvinyl chloride (PVC). Although PVC is hard, with the addition of plasticizers it can be made pliable enough, for example, to coat fabrics in any thickness.

In 1926, Waldo L. Semon, a scientist working for BF Goodrich, accidentally discovered this compound

while trying to form a synthetic rubber. At first he thought that the rubbery gel he created would work as a bonding agent to adhere rubber to metal. However, through further experimentation he found he had invented a highly versatile plasticized vinyl that, in the early 2000s, has hundreds of uses.

To present his discovery to the company, Semon applied the gel to curtains, creating a waterproof vinyl-coated shower curtain. It stirred a sensation! Vinyl was quickly adapted to umbrella and raincoat fabrics for its waterproof properties. Vinyl was also used to coat wires. Commercialized in 1931, the new technology was highly successful. During World War II, vinyl was turned to wartime use, and so it wasn't until the 1960s that vinyl again became a fashion item.

The 1950s were times for conformity, particularly in clothing. By the 1960s the public was ready to have fun with fashion, and clothes reflected the radical social change of that decade.

In the mid 1960s couture designers André Courrèges, Pierre Cardin, and Paco Rabanne, noted for their modern and futuristic looks, seized upon the high-tech look of these fabrics. Vinyl-coated fabrics not only gave a new surface appeal to their designs, but lent a modern structural look to the designers' new vision of architectural shapes rather than fluid draped lines. Modern clean-lined geometric shapes characterized their designs. Garments were cut to suggest simple geometric forms, boxy with hard edges, angular straight lines, or circular in shape.

André Courrèges, who claimed to have invented the miniskirt, made vinyl fashionable with his miniskirts, helmets, A-line dresses, and suits. Inspired by astronaut boots, he used vinyl in his "Moon Girl Collection" to create the shiny white boots that accessorized his designs. The "Courrèges boot" was mid-calf length with open slots at the top and a tassel or bow in front. Soon the look was being copied everywhere. Popularized by teenagers wearing the boots on discotheque television shows, they were soon called "go-go boots" after the go-go dancers who wore them.

At the same time in England, the "Mod" fashion look first appeared on London's King's Road and Carnaby Street. The op art and pop art movements inspired the trendy English designer Mary Quant. She popularized the miniskirt, high vinyl boots, and shoulder bags. She used vinyl-coated fabrics to create what was called the "wet look" not just in raincoats, but in tight miniskirts and dresses as well.

Through the years vinyl coating was able to take on matte and textured surfaces to look more like leather for a cheaper alternative. Vinyl can also be produced in almost any color or can be crystal clear.

The downside of vinyl for cloth is that it does not "breathe." It also does not readily break down when discarded, lasting for decades. However, it can be recycled and converted to new applications.

After its first trendy appearance, vinyl's popularity in rainwear was only occasional because the vinyl coating rendered the fabric unbreathable. Wearing the coat, or other article of vinyl clothing, can become very uncomfortable, keeping heat and moisture trapped next to the skin. Also, although the fabric is waterproof, the garment isn't. In a heavy downpour water can get in through the seams. In the early twenty-first century, hi-tech fabrics and new construction methods have taken over the waterproof category in clothing, but the use of vinyl in other areas continues to grow.

See also **High-Tech Fashion; Rainwear; Umbrellas and Parasols.**

#### BIBLIOGRAPHY

- Bernard, Barbara. *Fashion in the 60's*. New York: St. Martin's Press, 1978.
- Carter, Ernestine. *With Tongue in Chic*. London: Joseph, 1974.
- . *The Changing World of Fashion: 1900 to the Present*. London: Weidenfeld and Nicolson, 1977.
- De Pietri, Stephen, and Melissa Leventon. *New Look to Now: French Haute Couture, 1947–1987*. New York: Rizzoli International, 1989.
- Fogg, Marnie. *Boutique: A '60s Cultural Icon*. London: Mitchell Beazley, 2003.
- Lagassé, Paul. *The Columbia Encyclopedia*. 6th ed. New York: Columbia University Press, 2000.
- Kamitsis, Lydia. *Paco Rabanne: A Feeling for Research*. Paris: Editions M. Lafon, 1996.
- Kellogg, Ann T., et al. *In an Influential Fashion: An Encyclopedia of Nineteenth- and Twentieth-Century Fashion Designers and Retailers Who Transformed Dress*. Westport, Conn.: Greenwood Press, 2002.
- Martin, Richard, ed. *The St. James Fashion Encyclopedia: A Survey of Style from 1945 to the Present*. Detroit: Visible Ink Press, 1997.
- Moffitt, Peggy, et al. *The Rudi Gernreich Book*. New York: Rizzoli International, 1991.
- O'Hara, Georgina. *The Thames and Hudson Dictionary of Fashion and Fashion Designers*. New York: Thames and Hudson, Inc., 1998.

#### Internet Resources

- National Inventors Hall of Fame. 2004. Available from <<http://www.invent.org/index.asp>>.
- Style.com. 2004. Available from <<http://www.style.com>>.
- The Vinyl Institute. 2004. Available from <<http://www.vinylinfo.org/index.html>>.
- "Waldo Simon—PVC Inventor." 2004. Available from <<http://inventors.about.com/library/inventors/blpvc.htm>>.

Mary Ann C. Ferro

**VIONNET, MADELEINE** Born in Chilleurs-aux-Bois in 1876, Madeleine Vionnet was apprenticed to a dressmaker while still a child. She began her career in fashion working for makers of lingerie, as well as dress-

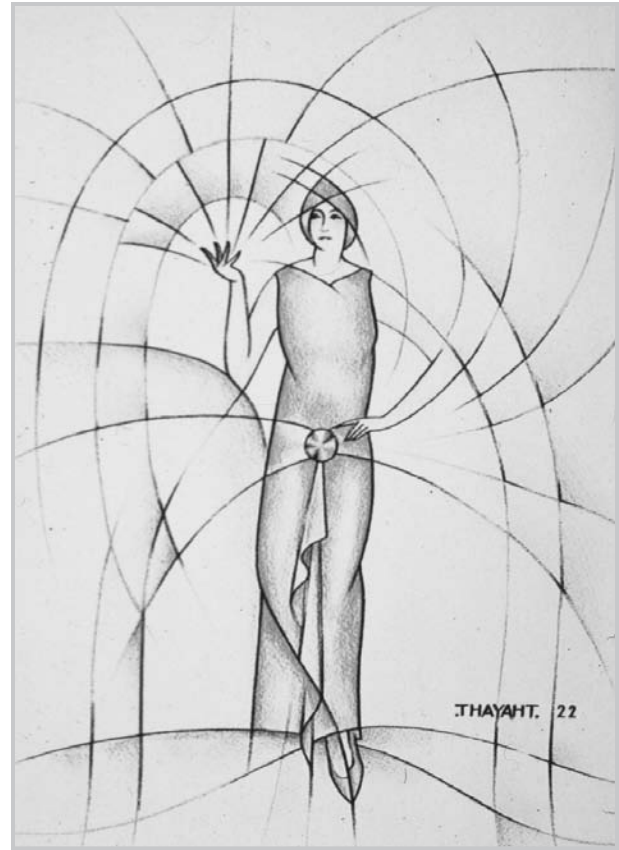

**Illustration of a Vionnet dress.** Madeline Vionnet helped to instigate fashion's exploration of private and public. Many found her designs controversial, and her main clients were stage performers. PHOTO BY JOHN S. MAJOR. REPRODUCED BY PERMISSION.

makers and couturiers in London and Paris. These early experiences of craft skills and, in particular, the relationship between body and fabric involved in making undergarments, influenced the future direction of her own designs. She learned to respect the intricate skills of craftspeople, who were able to produce delicate effects through, for example, drawn threadwork and fagoting, which created spatial patterns by moving and regrouping the fabric's threads. This fascination with minute detail and the possibilities of fabric manipulation formed the foundation of her approach. Her background in the couture trade was fundamental to her later status, since it distinguished her as a craftsperson who was knowledgeable about the various dressmaking skills and decorative trades that supported designers. She was therefore not only tutored in practical skills but was also aware of the status and treatment of young women who worked in the ateliers.

#### Birth of Vionnet's Design Philosophy

Around 1900 Vionnet moved to Callot Soeurs's celebrated couture house in Paris. There she began to understand the significance of garment design that sprang

from draping fabric directly onto a live model, rather than sketching a design on paper and then translating it into fabric. This approach necessarily focused attention on the body and its relationship to the way fabric was draped and sculpted around its contours. Vionnet exploited this technique to the full. For Vionnet, draping—in her case on a miniature, eighty-centimeter mannequin—became crucial to her design philosophy. It enabled her to think of the body as a whole and to mobilize the full potential of the springy, malleable, silk crêpes she came to favor.

At Callot Soeurs these methods were combined with an acute awareness of fashion and style, as skillful designers and saleswomen sought to mold couture's elite tastes to each client's particular figure and requirements. Vionnet encountered high fashion and learned its seasonal rhythms, while she experimented with the dressmaking skills she had acquired over the years. An example of this was her adaptation of Japanese kimono sleeves to Western dress, which produced deeper armholes that made the silhouette less restrictive and enabled the fabric to flow and drape around the upper body. This early innovation incorporated several of what were to become Vionnet's trademarks. For example, her use of Asian and classical techniques freed fabric from established Western dressmaking methods that tended to fix the cloth, and therefore the body, into position. Her focus upon draping and wrapping rather than cutting and tailoring to the figure enabled her to achieve maximum fluidity, enhancing movement and flexibility. Her concentration on experimental construction techniques tested the boundaries of design and dressmaking and allowed her to create clothing that derived its significance from subtle reconfigurations of cloth, rather than from dramatic surface decoration. For Vionnet minute attention to detail was paramount.

Vionnet's career may have started during the late nineteenth century when fashion was predicated upon exaggeration, novelty, and decoration, but there were already intimations of new types of femininity and clothing that would enable greater physical freedom. These came partly from utopian dress reform movements, but also from other designers, such as Fortuny, who used historical dress as a source for comfortable yet luxurious dress.

### Daring Designs

When Vionnet moved to the house of Doucet in 1907, she became more daring in her display of the female figure, inspired by avant-garde dancer Isadora Duncan's barefoot movements and by her own desire to strip fashion to its essential elements: fabric and body. She insisted that Doucet's models walk barefoot and corsetless into the couturier's salon for his seasonal fashion show. Her dramatic exposure of the models' skin enhanced the fall of the fabric as they moved and brought sudden focus onto the natural figure.

Vionnet helped to instigate modern fashion's exploration of private and public, with her designs' reliance

upon a sophisticated interplay between sheer and opaque fabrics draped to swirl about the skin. Many found her work too controversial, and her main clients were stage performers, used to their public roles and more ready to experiment with avant-garde fashions. The *déshabillé*, a fashionable and fluid garment previously worn in private, became acceptable, if still daring, for entertaining at home. In Vionnet's hands its light drapes created a shimmering cocoon reminiscent of lingerie. For example, the French actress Lantelme was photographed in 1907 in a loose tea gown, the pastel tones and matte glow of its layered chiffon illuminated by beading and sequins.

### Classical Influences and Cutting on the Bias

In 1912 Vionnet opened her own house in the rue de Rivoli. It was closed, however, at the outbreak of war in 1914, and Vionnet moved to Rome for the duration. Her experience there, as well as her studies of ancient Greek art in museum collections, became another crucial aspect of her work. Classicism, both as an aesthetic and design philosophy, provided Vionnet with a language to articulate her belief in geometrical form, mathematical rhythm, and the strength of proportion and balance as a basis for the garments she created.

During the late teens Vionnet focused on the process of wrapping lengths of fabric onto the body in the style of the Greek chiton. Through these experiments she exploited the advances made in fabric technology during World War I that had produced yarns that could be made into more supple fabrics, and she had extra wide lengths of material created for her to allow even greater drape. Vionnet was thus able to push her examination of construction methods that not only draped but twisted fabric still further than before; moreover, she formulated the potential of the bias cut for which she is so often remembered. To do this she cut the fabric diagonally, across the grain, to produce a springy, elastic drape. Although cutting on the bias had been used for accessories and had been applied to fixed, molded dress forms, it had not been used this extensively for the body of a garment. Vionnet took an experimental leap forward in her desire to release both fabric and figure from the tight-fitting ethos of traditional Western dressmaking.

Vionnet reduced the use of darts, often eliminating them completely and therefore allowing bias-cut fabric to hover freely around the body. She also introduced lingerie techniques—such as roll-tucked hems or fagoting to disguise the line of a seam—to both day and evening wear. Her designs aimed for simplicity of overall form and impact, while they frequently employed complex construction techniques.

One of the most dramatically minimal of her designs was a dress from 1919–1920, now in the collection of the Costume Institute at the Metropolitan Museum in New York. It demonstrates Vionnet's search during this period of her career for new ways to push the boundaries of the fabric while maintaining tight control over the ul-



timate hang of the garment. In this example she used four rectangles of ivory silk crêpe, two at the back and two at the front, held together at one point to form the shoulders of the dress. The rectangles hang down the body from these two points, to form two diamond forms of mobile fabric at front and back. Vionnet, in the act of turning the geometric shapes onto the diagonal for the final dress, swung the weave onto the bias. Thus the dress is stripped of dressmaking's usual devices to nip and sew the material for a "fit" with the body beneath; Vionnet instead used the movement released in the fabric to flow and drape around the wearer as she walked and danced. The deep drape of the fabric created vertical bands of light flowing down the figure. These elongated the silhouette, which was first blurred and then brought into relief as the wearer's movements caused the swathes of fabric to shift and form anew.

In Vionnet's hands the bias cut was a means to rethink the relationship between fabric and flesh. She constantly tested the methods she had learned during her early career, and her attention to anatomy led to her use of bias cutting not just to allow material to cocoon the figure, but to produce sophisticated forms of decoration. She varied the direction of the material's grain to encourage light to bounce off contrasting matte and shiny pattern pieces. The complexity of her construction techniques meant that her designs came alive only when worn or draped on the stand. They were conceived for the three dimensions of the body and cut to smooth over the figure: evening dresses dipped into the small of the back; day dresses slid under the clavicle to form a soft cowl neckline; and bias-cut fabric draped artfully to allow for the curve of the stomach or the arch of hip bones.

### Futurist Influences

Such effects were only enhanced as the wearer moved, and Vionnet's interest in contemporary art, and in particular futurism, served to develop this exploration of movement as a further expression of modernism. The illustrations that artist Thayaht produced for the *Gazette du bon ton* in the 1920s expound futurism's view that art should represent the dynamics of the body in movement. His drawings show women in Vionnet outfits, with lines tracing the curves of the dress into the surrounding environment to suggest the flow of the body, and the fabric, as they walked. He wanted to express the sensation of the space between body and material, and between the material and the space the wearer inhabits, as alive with friction and loaded with the potential to blur air and matter.

Vionnet's approach explored women's modern lives and sought to express an adult, liberated femininity. Like modern artists she was interested in the integrity of the materials she used. She also exploited technology by experimenting with new ways to dye fabric, and she was driven to create clothes that broke away from highly decorative, constraining forms of fashion that relied upon historical notions of femininity. However, while she de-



"My efforts have been directed towards freeing material from the restrictions imposed on it, in just the same way that I have sought to liberate the female form. I see both as injured victims...and I've proved that there is nothing more graceful than the sight of material hanging freely from the body."

Madeleine Vionnet, quoted in Milbank 1985.

scribed her clothing as appropriate for any body size or shape, its revelatory exposure of the natural form, and the prevailing ideal of youth and athleticism, meant her designs can be seen as part of the twentieth century's shift toward bodies controlled from within, through diet and exercise, rather than through restrictive undergarments.

### Classicism and Ornamentation

In 1923 Vionnet moved her couture house to 50 avenue Montaigne, where its salons were decorated in a classically inspired, modernist manner that formed a suitable backdrop to her work. The salon used for her seasonal shows contained frescoes that showed contemporary women clad in some of her most popular designs, intermingled with images of ancient Greek goddesses. Thus clients could measure themselves against classical ideals and see Vionnet's designs through the prism of a revered, idealized past. This placed her designs, which could seem so daring in their simplicity, within the context of classical antiquity's noble precedent and articulated the link between her own focus upon mathematical harmony and that of the past.

The various ateliers that produced her collections showed the diversity of her output and her ability to imbue a whole range of different types of clothing, from sportswear to furs, lingerie, and tailored clothes, with her ethos of creative pattern-cutting and subtle, supple silhouettes. Her daywear also relied upon the material's inherent properties and the possibilities to be explored in her integration of construction techniques and decoration. Discreet day dresses were pintucked in neat rows, whose spacing gently pulled fabric in toward the figure at the waist and curved diagonally across the body from shoulders, across the bust, around the hips, and round toward the small of the back to shape the dress. Thus Vionnet's garments were given shape while maintaining smooth, uncluttered silhouettes, and the tucks of materials created a pattern on the fabric's surface.

During the 1920s, when heavy beadwork and embroidery proliferated, Vionnet was committed to search for methods of ornamentation that took part in shaping the whole garment. Narrow pintucks were used to form

her signature rose motif, its size subtly graduated to pull dresses toward the wearer's figure. For Vionnet such exact craftsmanship enabled her to challenge traditional methods continually. Even when she used beadwork, most famously on the 1924 Little Horses dress, she demanded an innovative approach. She commissioned couture embroiderer Albert Lesage to explore new ways to apply bugle beads to bias-cut silk, so that the flow of the fabric would not be interrupted and the images of glittering horses inspired by the stylized, representational forms on Grecian red figure vases would not be distorted by the beads' weight. Even thick furs and tweeds could be given greater fluidity and form through her manipulation of their drape and use of pattern pieces cut to sculpt and form around the figure.

### Business Growth

Vionnet's couture house grew during the 1920s, and she opened a branch in Biarritz to provide everything from spectator sportswear and travel garments—a growing market as women led increasingly active lives—to her supple evening wear for dinners and dances. By 1932 her Paris establishment had grown, despite the impact of the Great Depression, to twenty-one ateliers. Her attitude toward her employees was as enlightened as her design approach. She remembered her own path through the studios' hierarchy and ensured that workers, while paid the same as in other couture houses, were provided with dental and medical care, had paid breaks and holidays, and were given help with maternity leave and proper teaching in her favored design techniques, such as bias cutting.

Vionnet set up her company, Vionnet et cie, in 1922, and with the support of her backers, she pursued a series of business schemes. These included several attempts during the mid-twenties to capitalize on America's reliance upon Parisian fashion for new trends and Vionnet's popularity there, through a number of deals with companies to produce ready-to-wear. Although innovative, these ventures were brief and did nothing to stem the tide of copyists, both in the United States and in France, who cost the couture industry large sums of money each season by plagiarizing original models and mass producing them at lower prices. This practice damaged Vionnet's profits and also reduced the cachet of particular outfits, since couture clients were paying, at least in part, for exclusivity. Despite Vionnet's involvement with a series of couture organizations pledged to track down copyists, and a landmark case in 1930, when Vionnet and Chanel successfully sued a French copyist, this plagiarism was a recurrent problem that haunted the couture industry.

### Legacy and Influence on Fashion Design

The last collection Vionnet produced was shown in August 1939 and acknowledged the current vogue for romantic, figure-enhancing styles. Fragile-looking black laces were traced over palest silver lamé, with appliquéd velvet bows to pull out and shape the lighter weight lace

overdress and add fashionable fullness to skirts. Vionnet closed her house on the outbreak of World War II. Her work had been hugely influential in both Europe and the Americas during the period between the wars. While she sought to stand outside fashion and create timeless clothing, her liquid bias cut became a defining emblem of 1930s sophistication and style and inspired Hollywood designers to use bias-cut gowns to create iconic images of actresses such as Jean Harlow. Her experiments with fabric control and manipulation and the advances she made in testing the boundaries of fabric construction left a complex legacy which has inspired designers as diverse as Claire McCardell, Ossie Clark, Azzedine Alaïa, Issey Miyake, Yohji Yamamoto, and John Galliano.

When Vionnet died in 1975, her place within the history of fashion in the early twentieth century was assured. Perhaps because of the lack of drama in her private life and her unwillingness to give many interviews, she was less well known than some of her contemporaries. However, Vionnet's focus on experimentation and her desire continually to redefine the relationship between body and fabric provided women with clothing that expressed the period's dynamic modernity.

Vionnet embraced the dressmaking skills she had learned as a child apprentice and elevated them to new levels of complexity, yet she always strove to produce finished garments that preserved, and indeed celebrated, the integrity of the materials she used and the natural shape of the wearer's body. She viewed couture as a testing ground for the new identities that the twentieth century created. Her clients became living embodiments of modern femininity, clad in garments inspired by contemporary art, Asian wrapping techniques, and classical antiquity. In Vionnet's hands these elements were united into dramatically simple silhouettes. Vionnet's intimate knowledge of cutting and draping enabled her to create clothing that expressed the dynamism and potential of women's increasingly liberated lives.

*See also* **Cutting; Embroidery; Film and Fashion; Lingerie; Tea Gown.**

### BIBLIOGRAPHY

- Chatwin, Bruce. *What Am I Doing Here*. London: Picador, 1990.
- Demornex, Jacqueline. *Vionnet*. London: Thames and Hudson, Inc., 1991.
- Evans, Caroline, and Minna Thornton. *Women and Fashion: A New Look*. London: Quartet, 1989.
- Kirke, Betty. *Madeleine Vionnet*. San Francisco: Chronicle Books, 1998.
- Koda, Harold, Richard Martin, and Laura Sinderbrand. *Three Women: Madeleine Vionnet, Claire McCardell, and Rei Kawakubo*. New York: Fashion Institute of Technology, 1987. Exhibition catalog.
- Milbank Rennolds, Caroline. *Couture: The Great Designers*. New York: Stewart, Tabori, and Chang, Inc., 1985.

*Rebecca Arnold*

**VOGUE** *Vogue* is fashion's bible, the world's leading fashion publication. It was founded in 1892 as a weekly periodical focused on society and fashion, and was subscribed to by New York's elite. Condé Nast (1873–1942) bought the magazine in 1909 and began to transform it into a powerhouse.

*Vogue* delivered beautifully presented, authoritative content under the leadership and watchful eyes of a few talented editors-in-chief. One of the most notable, Edna Woolman Chase, became editor in 1914 and remained at its helm for thirty-eight years, until 1952. Caroline Seebohm, Nast's biographer, credits Chase with introducing new American talents to the fashion audience. Chase gave full coverage to European, and especially Parisian, fashions, but her approach also suggested that American women might exercise a certain independence of taste.

Chase's successor, Jessica Daves, served as editor in chief from 1952 to 1963 and is remembered primarily for her business acumen. She was followed by the flamboyant Diana Vreeland, whose eight-year tenure (1963–1971) documented "Youthquake," street-influenced youth fashions, and space age and psychedelic fashions. Vreeland's successor was her colleague Grace Mirabella, who served as editor-in-chief from 1971 to 1988. Mirabella was the antithesis of Vreeland; her watchwords for fashion were functionality and affordability. Whereas Vreeland wrote in 1970, "In the evening we go east of the sun and west of the moon—we enter the world of fantasy," Mirabella countered, in 1971, "When you come to evening this year, you do not come to another planet." Mirabella approached the "antifashion" 1970s with a levelheaded stance that addressed a growing constituency of the magazine: the working woman.

Anna Wintour became editor-in-chief of the magazine in 1988 and combined a shrewd and appealing mix of high and low. Her first cover for the magazine, in November 1988, featured model Michaela in a jeweled Lacroix jacket—worn with blue jeans.

A controlling interest in Condé Nast Publications was acquired in 1959 by S. I. Newhouse, who subsequently became the sole owner of the corporation. There are now more than twelve editions of *Vogue*: American, Australian, Brazilian, British, French, German, Greek, Italian, Japanese, Spanish, Taiwanese, Chinese, and Korean. *Teen Vogue* was launched in 2003. (Nast inaugurated the international editions with British *Vogue* in 1916 and French *Vogue* in 1920.)

Nast's original "formula" for *Vogue* was based on service, which Seebohm translates as disseminating fashion information to his readers as efficiently and clearly as possible. Clarity did not exclude creativity, and the magazine became well known for its own stylish look. *Vogue*'s most famous art and creative directors were M. F. (Mehmed Fehney) Agha, who started at *Vogue* in 1929, and Alexander Liberman, who joined the staff in 1941.

The magazine has employed the foremost illustrators and photographers of its times. (The first photographic cover appeared in 1932; color printing was introduced in the following year.) Its glossy pages maintain the highest standards for the visual presentation of fashion. *Vogue* is still the stuff that many dreams are made of.

See also **Fashion Editors; Vreeland, Diana.**

#### BIBLIOGRAPHY

- Chase, Edna Woolman, and Ilka Chase. *Always in Vogue*. New York: Doubleday and Company, 1954.
- Daves, Jessica. *Ready-Made Miracle*. New York: G. P. Putnam's Sons, 1967.
- Dwight, Eleanor. *Diana Vreeland*. New York: William Morrow and Company, 2002.
- Mirabella, Grace. *In and Out of Vogue: A Memoir*. New York: Doubleday and Company, 1995.
- Seebohm, Caroline. *The Man Who Was Vogue: The Life and Times of Condé Nast*. New York: Viking Penguin, 1962.

Laird Borrelli

**VON FURSTENBERG, DIANE** Diane von Furstenberg was born Diane Simone Michelle Halfin in Brussels, Belgium, in 1946. Her introduction to fashion was as an assistant to a photographer and filmmaker's agent in Paris, her first job on leaving the University of Madrid and graduating in economics from the University of Geneva. Familiar with the 1960s jet-set life, she married Prince Egon von Furstenberg in 1969 and moved with him to New York. They were a glamorous couple, luminaries of society columns, and attended celebrity parties and balls. However, in keeping with the burgeoning feminist movement of the early 1970s, and wishing to be financially independent, von Furstenberg realized the significance of women's emergence into the world of work. She capitalized on women's desire for simple, wearable clothes that were flattering but also smart. From 1970 to 1977 she became the owner-designer of the Diane von Furstenberg Studio, which produced easy to wear polyester, cotton, and silk knit dresses in her signature prints. Her iconic wrap dress, however, which first appeared in 1973, established her reputation as the designer of the moment and promoted her name into a worldwide brand.

Von Furstenberg's wrap dress was practical, versatile, and sexy. Manufactured at the Ferretti factory in Italy, the dresses were initially stored and the orders processed in the dining room of her home. Cut to flatter, the dress wrapped in front and tied at the waist and was made from drip-dry cotton jersey. She remembers in her autobiography, "I had no focus groups, no marketing surveys, no plan. All I had was an instinct that women wanted a fashion option beside hippie clothes, bell-bottoms, and stiff pant-suits that hid their femininity."





**Diane von Furstenberg.** Sexy, flattering, and also easy-to-wear, von Furstenberg's styles responded to women's changing desires and needs in the era of women's liberation.

In 1975 she brought out a scent, Tatiana, named after her daughter. She expanded into home furnishings with The Diane von Furstenberg Style for Living Collection for Sears, and in 1977 she reorganized the company to deal solely with licensees for the fashion line, luggage, scarves, cosmetics, and jewelry. By the end of 1979 the combined retail sales of all the products bearing the von Furstenberg name came to \$150 million. The extent of the licensing deals undermined the quality of the brand, however, and she closed her business in 1988.

The 1990s predilection for 1970s fashion meant that the wrap dress achieved cult status and was eagerly sought after from vintage shops. Following her success on the QVC home-shopping channel, von Furstenberg and her daughter-in-law, Alexandra, relaunched the business in 1997 and put the wrap dress back into production, this time in silk jersey with a new range of colors and prints.

Diane von Furstenberg will always be identified with the wrap dress; it typifies the era of women's sexual and political liberation. Its reemergence is evidence of the continuing desire of women for simple, one-stop dressing that is both flattering and versatile.

See also **Fashion Designer; Fashion Marketing and Merchandising.**

#### BIBLIOGRAPHY

Milbank, Caroline Rennolds. *New York Fashion: The Evolution of American Style*. Harry N. Abrams, 1989.

von Furstenberg, Diane. *Diane: A Signature Life*. New York: Simon and Schuster, 1998.

Marnie Fogg

**VREELAND, DIANA** Diana Vreeland (1903–1989) was, and continues to be, an iconic figure in fashion history, whose distinctive personal style and penchant for fantasy influenced her work at *Vogue* and the exhibitions she organized at the Costume Institute of the Metropolitan Museum of Art. Diana Vreeland was born in Paris in 1903 to Emily Key Hoffman and Frederick Young Dalziel. The Dalziels moved to New York in 1904, where the socially eminent family enjoyed a prosperous lifestyle. According to Vreeland's biographer, she was a vivacious child who was interested in fantasy and the transforming powers of artifice from a very young age. In 1924, Diana married Thomas Reed Vreeland, a socially prominent banker. The couple moved to London in 1929, where they remained until 1933. In London Vreeland started her career in fashion by opening a lingerie shop in the city, and her frequent visits to Paris familiarized her with haute couture. As a patron of designers such as Jean Patou, Elsa Schiaparelli, Madeleine Vionnet, and Mainbocher, Vreeland's flair for dressing, combined with her social standing, made her the subject of commentary in the social pages and in magazines such as *American Vogue*, *Harper's Bazaar* and *Town and Country*.

#### *Harper's Bazaar and Vogue*

The Vreelands moved back to New York in 1935. Diana began her first job in fashion editorial work at *Harper's Bazaar* in 1937. She was promoted to the position of fashion editor in 1939, working under editor-in-chief Carmel Snow, and remained at the magazine until 1962. Vreeland first came to the readership's attention with her 1936 column entitled "Why Don't You?" The feature encapsulated her personal belief in the ability of fashion to transform women by offering such extravagant and fantastic suggestions to her readers as "Why don't you ... Turn your child into an Infanta for a fancy dress party?" (August 1936) and "Why don't you own, as does one extremely smart woman, twelve diamond roses of all sizes?"



"Mrs. Vreeland is unquestionably the Madame de Sévigné of fashion's court: witty, brilliant, intensely human, gifted like Madame de Sévigné with a superb flair for anecdotes that she communicates verbally rather than in epistles, Mrs. Vreeland is more of a connoisseur of fashion than anyone I know" (Beaton, p. 359).

(January 1937) Vreeland honed her editorial skills at *Harper's Bazaar* by working closely with such photographers as Richard Avedon and Louise Dahl-Wolfe to implement her ideas and transfer her imaginative vision to the fashion pages.

Vreeland became publicly known as the archetypal fashion editor, famous for such proclamations as "Pink is the navy blue of India" (Donovan). Her inimitable persona was further popularized when she was parodied in the 1957 film *Funny Face*.

In 1962, Vreeland moved to American *Vogue* as associate editor. In 1963, Sam Newhouse, the owner of Condé Nast, promoted her to editor-in-chief in an effort to re-energize the magazine. Having complete control over the look of the magazine, she imbued its pages with her distinctive style and flair for the fantastic. During Vreeland's tenure, the magazine's editorial spreads presented a popular audience with exoticism, aristocratic glamour, and such atypical models (atypical because of their youth, multicultural appearance, and unisex body types) as Veruschka, Penelope Tree, Twiggy, and Lauren Hutton. Vreeland firmly believed that the magazine had the ability to transport the reader, just as clothing had the ability to transform the wearer. The mundane realities of life did not interest her.

### The Costume Institute

By the late 1960s, Vreeland's extravagant fashion editorials were deemed out of touch with the times and her position at *Vogue* was terminated in 1971; she was replaced by Grace Mirabella. In 1972, Vreeland became involved with the Costume Institute at the Metropolitan Museum of Art, the museum's acclaimed collection of historic costumes. Vreeland's fashionable and colorful personality was perceived as an opportunity to revitalize the costume exhibitions. Vreeland was brought in with the title of special consultant and acted as a creative director for twelve exhibitions from 1972 through 1985. Through these highly popular exhibitions, which included "Balenciaga," "The Eighteenth-Century Woman," "Romantic and Glamorous Hollywood Design," "The Glory of Russian Costume," "La Belle Époque," and "Yves Saint Laurent," Vreeland succeeded in placing her distinctive stamp upon the museum world. She transferred her unique style of fashion marketing to the museum gallery, taking inspiration from the runway, retail trends, fashion editorials, and her own fertile imagination. Her costume exhibitions were spectacular sensory experiences; as she herself admitted in her autobiography, she was interested more in effect than historical accuracy.

In 1976, she received the medal of the Legion d'Honneur from France for her contributions to the fashion industry. In 1984, she published her memoirs, entitled *D.V.* Vreeland died in New York City in 1989, but her status as an icon has had a lasting influence on the world of fashion. In 1993, the Costume Institute celebrated her memory with an exhibition entitled "Diana



**Diana Vreeland, 1973.** Vreeland stands with a Balenciaga coat at the Costume Institute at the Metropolitan Museum of Art in New York City. © BETTMANN/CORBIS. REPRODUCED BY PERMISSION.

Vreeland, Immoderate Style." She was the subject of a one-person off-Broadway play entitled *Full Gallop* in 1995. The repeated reexamination of Vreeland's impact on fashion attests to her impact as an arbiter of style who fostered the visibility of fashion on a popular level.

*See also* Avedon, Richard; Dahl-Wolfe, Louise; Fashion Editors; Fashion Icons; Fashion Magazines; Fashion Models; Fashion Museums and Collections; Vogue.

### BIBLIOGRAPHY

- Beaton, Cecil. *The Glass of Fashion*. Garden City, N.Y.: Doubleday, 1954.
- Donovan, Carrie. "Diana Vreeland, Dynamic Fashion Figure, Joins *Vogue*." *New York Times* (28 March 1952).
- Dwight, Eleanor. *Diana Vreeland*. New York: HarperCollins Publishers, Inc., 2002.

Martin, Richard, and Harold Koda. *Diana Vreeland: Immoderate Style*. New York: Metropolitan Museum of Art, 1993.

Silverman, Debora. *Selling Culture: Bloomingdale's, Diana Vreeland, and the New Aristocracy of Taste in Reagan's America*. New York: Pantheon Books, 1986.

Vreeland, Diana. *D.V.* Edited by George Plimpton and Christopher Hemphill. New York: Alfred A. Knopf, 1984.

*Michelle Tolini Finamore*

**VUITTON, LOUIS** Born in 1821 in Anchay, France, Louis Vuitton worked as an apprentice for the packing-case maker M. Maréchal, where he created personal luggage for Empress Eugénie before setting up his own business in 1854. Vuitton's career as a craftsman trunk maker quickly brought him an ever-expanding roster of clients, requiring him to move to workshops at Asnières, on the outskirts of Paris, in 1859. The workshops remain at the original site, and this is where all the luggage and accessories are still made. Annexed to the workshops is the family home, which is now a museum.

Vuitton's first innovation was to pioneer a gray, waterproof canvas (Trianon), which was stretched across the poplar wood structure of the trunk, eliminating the need for a dome-shaped lid, which had been essential for repelling rain from the trunk during transit atop a horse-drawn carriage. This innovation enabled porters to stack trunks one on top of the other, allowing travelers to take more luggage with them on trips.

Vuitton's success in the luxury luggage market was due to his willingness to modify and custom-build luggage that was adaptable to new forms of transportation. For example, cabin trunks for ocean liners were designed to fit under daybeds so as to maximize use of space. Yet what the luggage contained was never a secondary concern, but of equal value in the definition of first-class travel. To meet the needs of these elite travelers, Vuitton devised the wardrobe trunk with interior drawers and hanging space with the advice of the couturier Charles Frederick Worth.

As the company prospered, its products were widely imitated, forcing Vuitton to change the canvas design from a striped to a checkerboard (or Daumier) design. His son Georges created the famous monogram canvas in 1896. The design was intended primarily to combat commercial piracy, although its orientalist, decorative design also reflected the fashion for all things Japanese at the end of the nineteenth century. Beyond the initials that feature as a tribute to his father, Georges's design bears three abstracted flowers, based upon a Japanese *mon* or family crest that, not unlike a coat of arms, was traditionally used to identify items made for and owned by a particular family.

International stature was assured for the company by the opening of a London store in 1885, a French store opposite the Grand Hotel in 1871, and distribution in America through Wanamaker's department store in 1898. Design awards at the Exposition Internationale d'Industrie et des Arts Decoratives of 1925 secured the company's reputation for grand luxe in the art deco style.

Later in the twentieth century, handbags, wallets, and other small leather goods became increasingly important parts of the company's product line, as luxe travel with numerous trunks and suitcases became largely a thing of the past. In 1997, the company hired the American fashion designer Marc Jacobs to design accessories and clothing. A commercial and critical success, the ready-to-wear collections have been central to the continued success of Louis Vuitton. Limited edition pieces produced in collaboration with other creative artists have resulted in some of the wittiest and shrewdest reworkings of brand identity. Fashion designer Stephen Sprouse (2001), British fashion illustrator Julie Verhoeven (2002), and Japanese artist Hideo Murakami (2003) have created some of the most popular designs.

The Stephen Sprouse collaboration was inspired by a visit Marc Jacobs made to Charlotte Gainsbourg's apartment, where he noticed a Louis Vuitton trunk that had once belonged to her father, the French singer Serge Gainsbourg. Gainsbourg had so disliked the status implied by the canvas design that he had tried to erase the symbols with black paint. Yet as the design is produced as a woven jacquard, he only made the design appear subtler, and in turn, more sophisticated. Sprouse was inspired to add graffiti over the monogram canvas in fluorescent colors as an ironic act of defilement. Yet the graffiti design only served to reinforce the status of the brand and its association with street credibility.

The consumption of luxury brands by American hip-hop performers, termed *bling-bling*, created a new and younger market for Louis Vuitton. This new market was memorably represented by the performing artist Lil' Kim, who posed on the cover of the November 1999 issue of *Interview* magazine naked, her body painted with the Louis Vuitton monogram.

Because they are such desirable status symbols, Louis Vuitton products are subject to intense counterfeiting, which the company vigorously combats. Vuitton remains the most prestigious and easily recognized brand of luggage.

*See also* **Leather and Suede; Logos.**

#### BIBLIOGRAPHY

Forestier, Nadege, and Nazanine Ravai. *The Taste of Luxury: Bernard Arnault and the Moët-Hennessy Louis Vuitton Story*. London: Bloomsbury Publishing, 1993.

*Alistair O'Neill*





**WAFFLE-WEAVE.** *See Weave, Jacquard.*

**WAISTCOAT** The waistcoat, or vest (as it is known in the United States), is a close-fitting sleeveless garment originally designed for men that buttons (or occasionally zips) down the front to the waist. Produced in either single or double-breasted styles, the waistcoat is designed to be worn underneath a suit or jacket, although it does not necessarily have to match. Similar garments are worn by women.

### History

Originating in Persia, waistcoats first became fashionable in the middle of the seventeenth century. The new style was noticed by Samuel Pepys in 1666: “The King hath ... declared his resolution of setting a fashion for clothes which he will never alter,” he wrote in his diary. “It will be a vest.”

King Charles II was persuaded that, after the Great Plague and the Great Fire of London, a much more sober form of attire should be worn by gentlemen, particularly in view of the gross extravagance displayed in the French court at the time. The vest was a knee-length garment that would follow the cut of the coat but would be much tighter in fit. It was designed to discourage the use of lavish materials (such as lace) by covering much of the body in plainer and cheaper material. By 1670, vests had become one of the most important European fashion trends of the time, particularly among nobility who would soon forget the notion of sobriety in favor of opulence and excessive decoration.

### 1700 to 1900

By 1700, many waistcoats became much shorter, with skirts reaching above the knee, and few had collars or sleeves. Waistcoat styles designed for sporting purposes did away with any skirt almost completely. As the waistcoat became short it also became more and more cut away in a curve at the front to reveal the wearer’s breeches. Whereas elaborately embroidered waistcoats were fastened with hooks and eyes, the majority were fastened with buttons that would match those of the coat being worn.

Double-breasted waistcoats were the most popular style during the first few decades of the eighteenth century and featured small pockets with flaps. By the middle of the century, rather than following the older style of having cuff-length sleeves, the majority of waistcoats were sleeveless; skirts were much shorter and by 1790 were cut square to the waist. Toward 1800, decorated single-breasted waistcoats with small lapels became fashionable; fabrics with horizontal or vertical stripes were particularly favored, especially if the waistcoat was finished with a silk trim.

By 1800, the waistcoat had become an increasingly decorative and flamboyant addition to the male wardrobe. Through various style trends at the time, the overriding principle was that as long as a waistcoat was highly conspicuous, ostentatious, and embroidered, it was deemed fashionable. Single-breasted, double-breasted, waist-length, square-cut, roll-collared, low stand-collared and flap-pocketed styles all were worn. Dandies at the time even took to wearing two waistcoats at once. One would be as elaborate as the other, with the upper unbuttoned to show the one underneath.

Generally speaking, after the mid-nineteenth century, waistcoats became much more sober. The majority were produced to match the jackets or suits they would be worn with, rather than being outward expressions of originality and wealth.

### The 1900s and Onward

Although the waistcoat was still deemed fashionable at the beginning of the twentieth century, its popularity soon began to wane. Rather than being worn as a show of wealth or decadence, the waistcoat was considered little more than a functional item to house a pocket watch or to finish off a formal evening wear outfit. With suits becoming softer and men opting for the growing trend of the wristwatch, the waistcoat was deemed less than essential for the male wardrobe.

That is not to say that the waistcoat simply died. Many men continued to wear a knitted waistcoat in the winter and a lighter version in the summer; however, it was now seen as an item simply to accompany and harmonize the rest of the outfit.

After World War II, few businessmen were wearing waistcoats to work, and right up to the Peacock Revolution in the 1960s, they had become all but extinct except with the more conservative dressers and those of an older generation. The waistcoat began to revive among fashionable young men, however, who associated themselves with style tribes such as Neo-Edwardians and Teddy boys.

The 1960s also saw the waistcoat move away from being a formal item when it was adopted by the hippies and incorporated as part of their ethnic-inspired or countrified look. The hippy version of the waistcoat still followed the contours of the body, but it tended to be longer than the waistcoat of a business suit; some were knee-length and featured heavy floral embroidery, fringing, and patchwork; some were tie-dyed (a look that would be recreated for the spring/summer 1993 collection by Dolce & Gabbana).

In the early twenty-first century, the waistcoat is seldom worn, except by businessmen trying to show some form of individuality or personality with a suit. Among conservative members of some professions, such as corporate law and banking, a three-piece suit (i.e., trousers, jacket, and matching waistcoat) is still regarded as the most appropriate business attire. But aside from designers such as Jean Paul Gaultier and Dolce & Gabbana reviving waistcoats for men during the 1980s and early 1990s, they are now more likely to be worn as novelty items than to be part of a classic tailored look.

See also **Dandyism; Jacket; Trousers; Uniforms, Occupational.**

#### BIBLIOGRAPHY

- Amies, Hardy. *A, B, C's of Men's Fashion*. London: Cahill & Company Ltd., 1964.
- Byrde, Penelope. *The Male Image: Men's Fashion in England 1300–1970*. London: B. T. Batsford, Ltd., 1979.
- Chenoune, Farid. *A History of Men's Fashion*. Paris: Flammarion, 1993.
- De Marley, Diana. *Fashion For Men: An Illustrated History*. London: B. T. Batsford, Ltd., 1985.
- Keers, Paul. *A Gentleman's Wardrobe*. London: Weidenfeld and Nicolson, 1987.
- Roetzel, Bernhard. *Gentleman: A Timeless Fashion*. Cologne, Germany: Konemann, 1999.
- Schoeffler, O. E., and William Gale. *Esquire's Encyclopedia of 20th Century Men's Fashions*. New York: McGraw-Hill, 1973.

*Tom Greatrex*

**WATCHES** Watches are portable timepieces, used to measure time and intervals. Historically, watches were worn as decorative pendants or carried in the pocket. In modern times, they are branded accessories most frequently worn on the wrist.

#### A Period of Decoration

At the beginning of the eighteenth century, watches were still considered to be primarily decorative objects because of their poor functionality. Men who could afford them typically wore pocket watches, which hung from a short chain and easily slipped into a waistcoat pocket. Women's watches were traditionally more embellished and visibly worn as a pendant or on a chatelaine.

The century marked a period of rapid technical development. Pioneered by organizations and guilds in Germany, France, England, and Switzerland, inventors introduced new types of springs, encasements, and bearings that allowed for better accuracy and performance under vacillating temperature and position. They also replaced the key-winding watch with self-winding movement. Some English and Swiss watchmakers, who utilized jeweled bearings and newer escapements to control the rate of wheel movement, were able to equip watches with a minute hand, which until then was impossible.

These advancements influenced the design and stylistic components of watches, which became much smaller and slimmer. Greater attention was also paid to the protection of the watch, as they became more useful. Circular or oval faces were encased on either the front or back, sometimes both, by a hinged cover. These covers, made from brass, gold, or silver, often displayed intricate engravings or enamels of pastoral scenes, portraits, or other related designs. Fob watches, which were attached on a short chain or ribbon and often held other gold charms, became popular around this time as well. Although watches still lacked the accuracy they had in later years, they sometimes had calendar, moon phase, or alarm functions.

#### Advancements in Accuracy and Production

As innovations in springs and bearings continued, watches became more accurate. Watchmakers now tried to make very complicated pocket and pendant watches incorporating calendars, timers, dual time zones, and moon phases. As such, dials became larger and the watches heavier.

The development of mass-production practices and interchangeable parts made it possible to produce watches by machine and in volume. These practices made watches significantly less expensive. In 1892 Timex (then called Waterbury Watch Company) and Ingersoll introduced the Dollar or "Yankee" watch that eponymously expanded the ownership of watches. Although decorative, luxury watches were still popular for women during this period, the functionality and usefulness of the watch increasingly became the focal point of fashionability.

#### Wristwatches and Alternative Power Sources

There is evidence that watches adjusted for the wrist existed in the late 1500s in special creations for royalty, yet wristwatches were not used in large numbers until the

early twentieth century. The first designs were military in nature—they were introduced as chronographs offering multiple-timing capabilities. These wristwatches were used during the Boer War, and later during World War I for their practicality on the front lines. It was easier and quicker to glance at a watch on one's wrist than to rummage through pockets during battle operations.

Despite the wristwatch's legacy of military use, the style spread first to civilian women. Designs for women during the early twentieth century were jewelry-inspired. Art-deco faces, inlays of onyx and marcasite, and straps of black silk or satin joined the more traditional existing designs of silver and gold braceleting.

By the end of World War II, however, wristwatches were worn by both men and women. Pocket watches were now considered outmoded. Simpler and sleeker designs predominated, epitomized by the Movado Museum watch, which consisted of a black dial free from markers or numbers, characterized only by gold hands and a gold dot at the twelve o'clock position. The importance of fashionability continued into the 1960s with young, pop art designs influencing watch case and face designs. Triangles, octagons, and hexagons accompanied standard round cases, and straps came in a greater variety of colors and fabrics.

Simultaneously, technology dominated the accessory, and much of the development during this time centered around new sources of power. In 1957, the Hamilton Watch Company introduced the first battery-powered wristwatch, and in 1970, the use of quartz crystals to produce an integrated circuit resulted in a watch that was infinitely more reliable than mechanical versions. Omega was one of the first companies to bring the battery-operated watch to market, soon followed by the Hamilton Watch Company's introduction of the Pulsar LED digital watch, an expensive innovation in line with the Space-Age obsession dominating the later 1960s and early 1970s. Swiss watch manufacturers, who had long held a reputation in the industry for manufacturing high-quality, precision, mechanical watches saw integrated circuitry as a temporary fad. It was not until the early 1980s, when the Swiss-based Swatch Group embraced quartz technology, and paired it with designs that responded to consumers' desire for accessories that conveyed lifestyle and personality, that the Swiss industry regained its vigor within the watch-making market.

### The Brand Speaks

Technological innovation remains an important component of the watch industry. Manufacturers market solar and kinetic watches, and some have introduced models equipped with global positioning systems, or those that link to computers or other portable electronic devices. Yet the wristwatch is also a fashion accessory for which aesthetics and brand are paramount. Fashion watches are associated with lifestyle, and many of the leading watch

companies have positioned themselves to appeal to certain segments of the consumer market. Luxury companies such as Rolex, Cartier, Movado, Tissot, Patek, and Breitling, who market through word-of-mouth, high-end event sponsorship, or specialized high-end fashion and lifestyle magazines, still appeal to wealthy consumers. A Cartier watch may cost more than \$10,000 and Rolexes or Movados are counterfeited as often as Gucci or Prada handbags. Mid-range watches, such as Fossil or Swatch, continue to sell in mid-priced jewelry and department stores, and Swatch remains well known for its wide range of strap and face styles. These companies have been joined by diversified companies, such as Nike, entering the watch market and promoting wristwatches designed for specific uses such as running or swimming. Lower-priced watches proliferate. Timex was one of the first companies to build its brand on selling through mass-market drugstores and stationery stores. In the early 2000s budget watches can be found almost anywhere: street markets, toy stores, and even inside fast-food kiddie meals. It is as uncommon not to own a watch in the twenty-first century as it was to own one at the beginning of the eighteenth. The watch has truly seen a revolution in time.

See also **Bracelets; Jewelry.**

### BIBLIOGRAPHY

- Bruton, Eric. *Collector's Dictionary of Clocks and Watches*. London: Robert Hale Limited, 1999. Comprehensive dictionary, but may be too advanced for new collectors.
- . *The History of Clocks & Watches*. London: Little, Brown, and Company, 2000.
- Childers, Catherine. *Master Wristwatches*. New York: BW Publishing Associates in association with Rizzoli International Publications, 1999.
- Doensen, Pieter. *Watch: History of the Modern Wristwatch: Design; 1950–1983*. Gent, Belgium: Snoeck, Ducaju and Zoon, 1994.
- Milham, Willis. *Time & Timekeepers Including the History, Construction, Care, and Accuracy of Clocks and Watches*. London: Macmillan, 1923. Good straightforward overview.

Leslie Harris

**WATERPROOFING.** See **Performance Finishes.**

**WEARABLE ART** Individual, often extremely personal, and generally conforming to no unifying aesthetic criteria, wearable art is by its very nature difficult to define. It could be called artwork for the body, but this does not acknowledge its complex relationship to the art world, the fashion world, and the world of craft. Wearable art is separate from mainstream fashion, yet remains related to it. Although wearable art takes varied forms—sculptural or flat—and employs diverse techniques such



as knitting, leather tooling, weaving, dyeing, and sewing, it shares a spirit of fantasy, craftsmanship, and commitment to personal vision.

The Wearable Art movement emerged at the close of the 1960s, flowered in the 1970s, and continues in the early 2000s. It is no accident that wearable art crystallized at the end of the tumultuous 1960s. The social, political, and cultural upheavals of that decade provided fertile ground for personal expression and explorations into body adornment.

During the 1970s “wearables” were generally unconventional works that celebrated the intimacy of creation through a highly individual artistic language. This intensely personal and narrative nature of wearable art distinguishes it from the earlier manifestations of artist-created garments that appeared beginning in the nineteenth century. Although it was not a direct linear development, wearable art owes its emergence to the climate of artistic expression cultivated by earlier avant-garde dress movements beginning a century before.

### Nineteenth Century

The Pre-Raphaelite Brotherhood, formed in 1848 by John Everett Millais, William Holman Hunt, and Dante Gabriel Rossetti, was one of the first collective efforts by artists to create alternative dress. In response to an increasingly industrialized society and mass-produced, cheap goods, the Pre-Raphaelites deliberately sought inspiration in Medieval and Renaissance art; they encouraged their wives, mistresses, and models to wear clothing modeled after earlier styles. These historically inspired garments appeared in their paintings and provided a sharp visual contrast to the prevailing Victorian fashions of tightly corseted bodices with full, bell-shaped skirts suspended over petticoats and hoops.

Sharing in this disdain for the voluminous and constricting fashions of Victorian England was William Morris, the man most closely associated with the British Arts and Crafts Movement. Like the Pre-Raphaelites, Morris sought to revitalize art and dress through a return to simplicity and hand craftsmanship inspired by historic models. Morris admired the paintings and decorative arts of the Middle Ages and advocated simple, picturesque attire, which he felt was more complimentary to a woman's natural form. His wife, Jane, was known to have adopted a form of plain dress without corsets or hoops.

Efforts to create alternative dress for women without the armature of hoops, bustles, and corsets had been at the forefront of the concurrent Dress Reform Movement. This movement emerged in the mid-nineteenth century and concerned itself primarily with health and comfort, rather than the appearance of dress. In contrast, a number of artists linked to the Aesthetic Movement of the 1870s objected to contemporary fashion on the grounds of taste rather than health. In the 1870s and 1880s, advocates of Aesthetic Dress championed a nat-

ural line in dress formed from soft, drapable fabrics without corsets or bustles. Rejecting the garish colors produced by the aniline (synthetic) dyes prevalent in contemporary fashion, advocates of Aesthetic Dress preferred muted earth tones in moss greens, browns, yellows, and peacock blues.

Aesthetic dress took a variety of forms. Some garments incorporated smocking and puffed sleeves in vaguely Renaissance styles, while others suggested “classical” drapery. Another strong influence on artists during the late nineteenth century was Eastern art, particularly Japanese woodblock prints and stencil-printed fabrics. Fascination with Eastern goods went along with this Japonism. Alternative dress in the form of kimonos and caftans became a popular form of anti-fashion for artists and intellectuals. James McNeill Whistler had a strong hand in designing the fashion of his sitters and, in fact, created the Japonese dress worn by Mrs. Frances Leyland in her 1873 portrait entitled *Symphony in Flesh Color and Pink*.

Aiding the efforts of the Aesthetes was Arthur Lazenby Liberty, whose emporium on Regent Street became a mecca for artists and enthusiasts seeking imported decorative arts from the Near and Far East, as well as fabrics in the soft greens, yellows, and browns so favored by Aesthetic dressers. In 1884, Liberty appointed the architect Edwin Godwin to direct a dress department thereby making artistic dress available to the public. Liberty's created a line of their own dresses with high waistlines and loose, puffed sleeves reminiscent of the Regency period of the early nineteenth century—a forecast of the direction that mainstream fashion would take in the early 1900s.

In the 1880s artistic dress gained a certain level of acceptance in mainstream fashion. Widespread acceptance of the tea gown, a loose, uncorseted informal gown worn at home, was one of the crowning achievements of Aesthetic Dress advocates. Moreover, the increasing influence of the British Arts and Crafts Movement led to efforts to expand reform and artistic dress. In 1890, The Healthy and Artistic Dress Union was formed and included Walter Crane, Henry Holiday, G. F. Watts, and A. F. Liberty. Their journal *Aglaia* featured several dresses designed in the classical mode by Walter Crane. The British Arts and Crafts Movement had a strong impact in America and stimulated a call for dress reform there. Gustav Stickley, chief spokesman for the American Arts and Crafts Movement, advocated beauty, comfort, and simplicity in dress in the journal *The Craftsman*, which had broad appeal to middle-class Americans.

A number of progressive artists and architects associated with art nouveau and art moderne espoused the belief that costume was the final frontier, an extension of the artistic effort to create unified interiors and exteriors. The Belgian architect Henry van de Velde designed dresses for his wife, as did the American architect Frank Lloyd Wright. In Vienna, Secessionist painter Gustav

Klimt collaborated with his wife, Emilie Flöge, herself a dressmaker, to create costumes. Wiener Werkstätte co-founder Josef Hoffmann was known to design not only the interiors of his clients' homes, but also their clothing.

### Early Twentieth Century

In the early twentieth century, unconventional artistic dress had achieved a certain level of acceptance. Wearing of artistic dress had even become a badge of distinction, bestowing upon the wearer an aura of progressive ideals, intellectualism, and good taste. These attributes were particularly accorded to the wearers of Fortuny dresses. Mario Fortuny y Madraz, born into a distinguished family of Spanish painters living in Venice, created Renaissance and medieval-inspired printed velvet gowns, as well as a simple columnar pleated silk dress inspired by ancient Greek sculpture. The latter dress, called the *Delphos*, was patented in 1909 and was produced, with slight variations, through the 1940s. Fortuny dresses became synonymous with simplicity, elegance, and timeless beauty and were favored by members of artistic and intellectual circles.

As the century progressed, a number of avant-garde painters also turned to the medium of fashion for artistic expression, viewing garments as the perfect form of kinetic, visual tableaux. Simultaneist and Rayonist artists Sonia Delaunay and Natalia Goncharova tried their hand at fashion design and worked for the Parisian couture houses of Heim and Myrbor, respectively. Even more extreme were the 1913 dress designs of Italian Futurist Giacomo Balla and the mass-produced work clothes created by Russian Constructivists Varvara Stepanova and Alexander Rodchenko. Jean Cocteau, Pablo Picasso, and even Ferdinand Leger took turns designing garments in the first quarter of the twentieth century.

Greenwich Village, New York, became the epicenter for avant-garde thinking and dressing during the 1910s and 1920s. Poets, writers, artists, socialists, feminists, and philosophers flocked to this shabby neighborhood to share their progressive ideas on life and art, that found expression in the clothes they wore. Greenwich Village became synonymous with bohemian and alternative fashion that included uncorseted, straight tunic dresses, loose jackets, and bobbed hair for women. Greenwich Village artists appear to be particularly associated with the revival of the batik technique that became a popular form of artistic dress decoration during the late 1910s and 1920s. This "anti-fashion" provides a link with the European artistic dress movements of the previous century and set the stage for avant garde experiments in dress later in the twentieth century.

In the 1930s, a renewed interest in handweaving led to a revival in that and other textile crafts in America, particularly after World War II, and is linked to the wearable art movement of the late 1960s and 1970s. This weaving revival was particularly accelerated by the arrival

of a number of Bauhaus-trained European émigrés in America during the 1930s and 1940s, such as Anni Albers and Marianne Strengell, who joined the teaching staffs of the Black Mountain College in North Carolina and Cranbrook Academy in Michigan, respectively. A generation later, their students pushed the boundaries of textile arts even further through their radical, off-loom woven sculptures of the late 1950s. Exploring the power of weaving, plaiting, dyeing, embroidery, knitting, and crochet, these fiber artists imbued the ancient techniques with new, expressive possibilities. Their creations paved the way for the wearable art movement that emerged ten years later. Wearable art carried on the exploration into textile techniques of the larger, inclusive fiber art movement.

### Late Twentieth Century

Wearable art was also the product of a unique climate of cultural and social change that occurred at the end of the 1960s. It came during a period that witnessed the flourishing of performance and body art concurrent with the rejection of traditional haute couture in favor of more democratic fashions inspired by hippies and street style.

Makers of wearable art in the late 1960s and 1970s did not attempt to influence universal trends in fashion. Rather, they chose to express a singularly personal vision of dress—a notion that separates them from earlier artistic dress movements of the nineteenth and early twentieth centuries.

With New York City and San Francisco as hubs, artists engaged in wearable art pursued works that fused aesthetics with function. At the heart of the wearable art movement was the rejection of traditional hierarchies in art that elevated fine art over craft. In the 1970s, wearable art incorporated materials that had traditionally held craft associations, embracing the formerly "women's work" of textiles as fine art. Paramount to wearable art in this early phase was the utilization of traditional techniques in unconventional ways. In the 1970s, ancient techniques such as sewing, leather tooling, weaving, knitting, and dyeing were suddenly enriched by the dimension of storytelling, such as in the fantastical, painted and tooled-leather garments of Nina Vivian Huryn. Other artists such as Janet Lipkin, Sharon Hedges, and Norma Minkowitz reinvigorated traditional crochet and knitting, producing new, voluptuous, and organic wearables.

One of the most pervasive forms of wearable art that emerged in the 1970s was that of the kimono. With its wide, untailed panels it provided the ideal surface for showcasing two-dimensional treatments. Eschewing structure for surface effects, Katherine Westphal was one of the first to exploit the T-shape kimono form, creating complex visual collages by the photocopy heat-transfer print method. Tim Harding is another artist who has excelled in this format in the past three decades, producing rich garments from sandwiched fabrics, manipulated to reveal layers of color and texture.

Validation of this nascent art form arrived with the landmark exhibition “Art to Wear: New Handmade Clothing” held at the American Craft Museum in New York City in 1983. This came ten years after Julie Dale’s had established her Artisan’s Gallery in New York as the premier gallery for displaying and selling wearable art. Artisan’s Gallery continues to showcase excellence in wearable art.

In the 1980s, wearable art became less organic and freewheeling. In keeping with concurrent developments in the visual arts, wearable works exhibited greater refinement in technique and a greater emphasis on surface imagery, rendered in a more controlled, graphic style. Crocheted and knitted garments by Jean Williams Cacededo illustrate this progression from the organic, sculptural works done in the 1970s to more graphic, flat appliqué works in the 1980s. Other artists such as Ana Lisa Hedstrom continue to explore and refine dyeing techniques inspired by Japanese traditional methods.

Wearable art in the 1990s and early twenty-first century continues to expand and gain greater acceptance in mainstream fashion. The exuberant and unwieldy forms of two decades past have been replaced with recent works that not only celebrate surface patterns, but also acknowledge the importance of comfort, drape, and fit. The work of Erman of Miami, Florida, embodies this new trend in wearables. Trained at several fashion houses on Seventh Avenue, Erman brings artistry and exquisite tailoring to his unique designs.

To some, the wearable art movement of the early 2000s is a splintered and unrecognizable entity, lacking the spirit of inquiry, exuberance, and integrity of the heady days of the 1970s and early 1980s. To others, wearable art has merely evolved into a larger, more diverse entity. Artists making wearables in the twenty-first century continue to explore techniques, but also show a new interest in computers and other technology. Moreover, wearable art has moved closer to mainstream contemporary fashion, revealing a stronger shared vision. As haute couture designers such as John Galliano and Alexander McQueen move increasingly into the “art-for-the-catwalk” realm, so wearable artists have exhibited greater practicality and business acumen in their garments, thereby appealing to a wider audience interested in craftsmanship, quality, and uniqueness in garments.

See also **Art and Fashion; Haute Couture.**

#### BIBLIOGRAPHY

- Aimone, Katherine Duncan. *The Fiberarts Book of Wearable Art*. Asheville, N.C.: Lark Books, 2002.
- American Craft Museum. *Art to Wear*. New York: American Craft Museum, 1983.
- Cunningham, Patricia. “Healthful, Artistic and Correct Dress.” In *With Grace and Favor: Victorian and Edwardian Fashions in America*. Cincinnati: Cincinnati Art Museum, 1993, pp. 14–25.

Dale, Julie Schafner. *Art to Wear*. New York: Abbeville Press, 1986.

Wollen, Peter. “Addressing the Century.” In *Addressing the Century: 100 Years of Art and Fashion*. London: Haywood Gallery, 1998, pp. 6–77.

Lauren Whitley

**WEAVE, DOUBLE** Double weave is a family of weave styles in which the face of the fabric is effectively disengaged from the back except at specific connecting interlacings, yet with each side maintaining sufficient individual structural integrity to be identified as distinct fabrics in themselves. Fabrics in this category include the matelassés and tubular fabrics. These fabrics are encountered in both decorative and utilitarian roles and occupy interesting extremes at either end of those spectra.

The matelassé types of fabrics are decorative in nature and may be found in use as bed clothings and upholstery. Utility double fabrics have been employed in roles as diverse as common garden gloves to highly technical, specialized end uses.

Double weaves are characterized by harness floats in paired or greater combinations on a face and different paired or greater float combinations on the back. The sets of floats are maintained as a distinct single fabric by warp yarns that alternate at long intervals between front and back of the cloth.

The simplest representations of double weave interlacings utilize both a point diagram and the filling cross section diagram to show alternations between top and bottom. In such diagrams, the warp yarns may be represented by each end to permit easier visualizations. Multiple repetitions of each end weaving pattern combine to permit the double face of a fabric.

Further considerations in double weaves include whether shuttle or shuttleless weaving techniques are used and whether simultaneous weft insertions in top and bottom sheds occur. If shuttle weaving is employed, a continuous loop of weft yarn is inserted across the width of the fabric. This technique permits the weaving of an unbroken, sealed tubular fabric. Technical uses of this fabric type include vascular grafts and spacesuit joints. In the latter role, a double weave tubular fabric was developed at Georgia Tech in the 1970s and 1980s by Dr. Howard Olson for elbow and knee joints as the first solution to prevent vascular destruction of astronauts’ arms and legs during bending motions.

If shuttleless weaving techniques are used, discontinuous segments of weft are being inserted and therefore tubular structures cannot be made on these machines. On the other hand, multiple simultaneous insertions of weft by rapiers is easily practiced by these machines, so top and bottom shed formations and independent insertions are possible. A subtype of these



double weaves are velvets, which are formed with a migrating binder warp that is cut after weaving to form a pile on the surface of either fabric base.

See also **Loom; Weave, Pile; Weave, Slack Tension; Weave Types; Weaving.**

#### BIBLIOGRAPHY

- Collier, B., and P. Tortora. *Understanding Textiles*. Upper Saddle River, N.J.: Prentice-Hall Inc., 2001.
- Emery, I. *The Primary Structures of Fabrics*. Washington, D.C.: The Textile Museum, 1980, pp. 156–160.
- Gioello, D. A. *Understanding Fabrics: From Fiber to Finished Cloth*. New York: Fairchild Publishers, 1982. See Double Cloth and Double-faced Cloth, p. 101.

Howard Thomas

**WEAVE, JACQUARD** Jacquard is a style of “figure weaving.” It can be used to create elaborate designs and detailed images of objects such as flowers and birds. This is done on a Jacquard loom, a device invented in Lyons, France by Joseph-Marie Charles Jacquard in the early 1800s. Before that time, figure weaves could only be made by more labor-intensive techniques such as tapestry, adding extra yarns to the surface of another weaving by hand (supplementary weft), using different sizes of yarns to make parts of the pattern stand out (dobby weaving), or by using a draw loom.

Draw looms were invented more than two thousand years ago in China and are operated by two people. The weaver sits at the front of the loom, adds the filling yarns, and beats them in place. An assistant sits at the side of the loom and lifts combinations of dozens (or even hundreds) of harnesses. These are frames with “heddles” that hold one or more yarns in place. Joseph-Marie Jacquard modified the draw loom by replacing harnesses with individual heddles attached to small weights. He also used a series of metal punch cards that could tell the loom the order and number of heddles to lift, replacing the need for a human assistant. Until the invention of computers, Jacquard looms were the most complicated pieces of machinery in the world. In fact, the punch cards used by early computers were based on the Jacquard system. In a reversal of fortune, Jacquard looms now use computers instead of cards to keep track of the pattern.

#### Appearance and Use

Jacquard fabrics have a distinct front and backside. The front shows the design in crisp detail, but the back is covered with long “floats.” These floats are yarns that were carried on the back of the fabric whenever they were not needed to form the design. Because the floats are easily snagged, the back of a jacquard fabric must be lined or hidden. An easy place to see floats is on the back of a clothing label—labels that are not printed are generally jacquard weavings.

As the design becomes more complex and the number of colors increases, more and more yarns have to be carried on the backside. This can make the cloth very heavy. For this reason, many jacquard fabrics are restricted for use in home furnishings. Brocade, made from silk or a synthetic material such as polyester, is one of the few figure weaves light enough for clothing. Although the mechanization of jacquard weaving has made it much less expensive to produce, brocade is still worn primarily for special occasions. Other figure weaves used in clothing, such as piqué and waffle weave, have a small textured pattern created by using a series of different yarn sizes. These patterns are less complicated than brocade and do not necessarily require a Jacquard loom.

Damask is a one-color, relatively lightweight cotton or linen jacquard fabric (originally produced on a draw loom) that is used for elegant curtains and tablecloths. Small floats on the surface are ironed or pounded flat (in a process called beetling) to make the cloth very smooth and lustrous. Heavier jacquard fabrics are used for upholstery and accessories such as shoes and handbags. Although these are sometimes called “tapestry,” real tapestries are extremely expensive and are made by a very different process.

See also **Tapestry; Weaving; Weaving, Machinery.**

#### BIBLIOGRAPHY

- Encyclopedia of Textiles*. 3rd ed. Englewood Cliffs, N.J.: Prentice-Hall, Inc., 1980.
- Kadolph, Sara J., and Anna L. Langford. *Textiles*. 9th ed. Upper Saddle River, N.J.: Prentice-Hall, Inc., 2001.
- Tortora, Phyllis G., and Robert S. Merkel, eds. *Fairchild's Dictionary of Textiles*. 7th ed. New York: Fairchild Publications, 1996.

Heather Marie Akou

**WEAVE, PILE** Pile weave is part of a family of woven fabrics created to produce pronounced or obvious protrusions of the constituent warp yarns within one set of the warp while a base structure of warp yarns maintains the tensile and structural integrity of the fabric in the machine delivery direction. The family of pile weaves includes terry cloth, velveteen, plush, and similar weaves in which a portion of the warp is extended to form an elongated, extended path from the flat plane of the fabric. Terry weave fabrics are traditionally used as houseware items for bath towels, mats, washcloths, and robes, but are occasionally used for apparel items such as beachwear. Other pile weave fabrics are usually associated with winterwear clothing items because of their softness and warmth.

The pile is defined as that set of yarns within the warp that is manipulated to allow large variations in the yarn interlacing lengths. The base structure of the warp that maintains a conventional mode of interlacings with

the weft and provides structural binding and load integrity is known as the ground.

Ground warps and pile warps are provided to the shedding and weft insertion sections of the weaving machine in separate deliveries. Conventionally, the ground and pile yarns are wound separately onto warp beams, but direct delivery of the pile from package creels is also possible in specialty weaves such as carpets.

Pile formation is executed by formation of floats on either the face, back or both sides of the fabric. During this float formation, the interlacing frequency of the warp in the ground direction is much more frequent, creating higher tension in the ground warp than in the pile. The fabric take-up is actuated based on the ground warp advance rate, so the pile warp length becomes necessarily greater than that of the ground. The extra length of the pile is utilized to create loops, long floats, billowed structures, and similar protrusions from the fabric surface. In the case of terry pile weaves, the advance rate of the pile exceeds that of the ground to such an extent that relatively long loops are formed that are manipulated to form alternatively above and below the surface of the fabric during weaving.

Pile weaves may be further enhanced or manipulated by variation in reed beating motion or variation of the position of the cloth fell during beat-up. In the first case, the reed sweep motion is restricted after some insertions and occasionally driven fully forward to allow maximum pile loop formation. In the case of variable fell position, the reed position and motion remain constant through each pick insertion; the cloth support, which determines the fabric fell location, is maintained in a position further away from shedding motion and closer to the take-up until loop formation is required. At loop formation, the fell is advanced simultaneously with and in opposite direction to the beat of the reed. The combination of the opposing reed and fell motions form the pile loop.

See also **Loom; Weave, Double; Weave, Slack Tension; Weave Types; Weaving.**

#### BIBLIOGRAPHY

- Collier, B., and P. Tortora. *Understanding Textiles*. Upper Saddle River, N.J.: Prentice-Hall Inc., 2001, pp. 312–316.
- Emery, I. *The Primary Structures of Fabrics*, pp. 148–149. Washington, D.C.: The Textile Museum, 1980.
- Gioello, D. A. *Profiling Fabrics: Properties, Performance, and Construction Techniques*. New York: Fairchild Publications, 1981.

Howard Thomas

**WEAVE, PLAIN** Plain weave (also known as tabby weave) is the most basic structure for producing cloth. When done by hand, the technique is like basket weaving: one filling (a crosswise or weft) yarn is drawn over, under, over, under, and so forth, through a series of warp

(extended lengthwise) yarns. The next filling yarn takes the exact opposite path (under, over, under, over, ...) and the whole pattern is repeated. When using a loom, a weaver alternates between raising all of the even-numbered warp yarns and all of the odd-numbered warp yarns, laying down successive filling yarns in each opening (shed) to create the same pattern. Although this technique has been in use since the late Stone Age, *Fairchild's Dictionary of Textiles* estimates that 80 percent of all woven textiles are made using plain weave.

#### Simple Variations

The continuing popularity of plain weave is due to its simplicity as well as to the many possible variations in color, texture, and yarn count. Plain weave is the least expensive fabric to produce. At the same time, weavers often purposefully use this pattern to avoid visual competition with other aspects of the cloth: textured fibers (such as linen and silk dupioni); novelty yarns (such as tweed, chenille, and bouclé); printed patterns (on fabrics such as calico and chintz); and dyed patterns (on fabrics such as batik, ikat, and tie-dye). Textiles that have a specialty finish, including flannel (napped), organdy (parchmentized), ciré and moiré taffeta (embossed), are also frequently plain weaves.

Georgette, chiffon, and voile (sheer fabrics that are used for scarves, bridal veils, and decorative overlays on full skirts and dresses) are plain weave fabrics made with tiny, highly twisted silk or manufactured yarns. The twisted yarns create minute spaces in the fabric allowing light or another color to show through. Softer fabrics used for dresses and skirts, such as cotton lawn and rayon challis, are made with yarns that have a very light twist. This helps make the surface of the finished cloth feel very smooth. China silk, a popular fabric for women's blouses, is a fine cloth with a high yarn count (large number of threads per inch). Buckram and crinoline, plain weave fabrics with a low yarn count, are used as stiff linings in the construction of elaborate hats and dresses. Muslin is a cheap, medium-weight plain weave fabric that is often used by tailors and designers to make a test garment before working with more expensive material.

Striped and plaid fabrics, such as tartan, madras, and gingham, are made by changing the color on sections of filling and/or warp yarns. Gingham, for example, usually has thin stripes of red and white or blue and white threads in the warp and identical stripes in the filling. In the finished cloth the stripes create a checkerboard pattern. This look can be imitated by printing the same pattern on a plain weave fabric. Chambray, a popular cloth for button-down shirts, is made with filling yarns that are one color (frequently white) and warp yarns that are a different color. When the filling and warp have a high color contrast, the overall fabric seems to shift color as it moves on the body. This is known as iridescence. Ikat fabrics have a multicolored warp that is dyed before the weaving process begins. When the weaver uses plain weave

and a neutral-colored filling yarn, the color and pattern of the warp yarns are allowed to stand out. A similar technique is used to produce fabrics such as tweed and chenille, where the goal is to highlight the texture of the novelty yarn. These bulky or fluffy yarns are usually in the filling. Simply using fewer yarns per inch in the warp and vice versa can also emphasize filling yarns.

Medium-weight plain weave fabrics are sometimes called “print cloth” because they’re often used for printed fabrics such as chintz and calico. The smooth surface of plain weave is excellent for printing. These fabrics are also low-cost, which balances out the expense of printing a textile. One drawback to plain weave, however, is that other structures such as twill weave and double weave are much stronger. Plain weave fabrics are best used for clothing and household furnishings that do not take much abuse (such as curtains) or are periodically replaced (such as underwear and bedsheets).

### Rib and Basket Weave

Changing the size or number of certain filling and/or warp yarns allows the creation of other variations of the plain weave. When several yarns are grouped together or larger yarns are used, a straight raised ridge called a rib or cord is formed. Poplin is a cotton or polyester fabric with very tiny ribs in the filling direction. This added thickness makes the cloth very crisp. Taffeta and faille, made of silk or a synthetic material such as acetate, are crisp fabrics with a slightly larger rib. Taffeta is often used to make ball gowns because the ribs make an elegant swishing sound when the fabric rubs together. Grosgrain ribbon is another fancy material with ridges in the filling direction. Bedford cord is a heavy fabric made as a lengthwise ribbed weave that resembles corduroy and is used for pants. Rip-stop nylon is a very strong fabric with noticeable ribs in both the filling and the warp direction. In this case, the ribs help prevent the fabric from tearing. Rip-stop is often used for sports gear such as windbreakers and athletic shoes.

Basket weave fabrics are made by having one or more filling yarns go over, under, over, ... more than one warp yarn at a time. This can be used to create a fabric that has a better drape and luster than standard plain weave, but the exposed yarns are more likely to be snagged. Oxford cloth, a popular fabric for men’s dress shirts, is a basket weave that has one filling yarn going under and over two warp yarns at a time. Heavier basket weaves, such as canvas and sailcloth, have been used for shoes and outdoor clothing such as jackets and overalls for construction workers, sailors, and hunters. Monk’s cloth, a very soft basket weave fabric that is easily damaged, has four yarns running together in both the filling and the warp direction.

See also **Batik; Calico; Chintz; Crinoline; Dyeing, Resist; Ikat; Muslin; Silk; Tartan; Tweed; Weave, Double; Weave, Satin; Weave, Twill; Weave Types; Weaving; Yarns.**

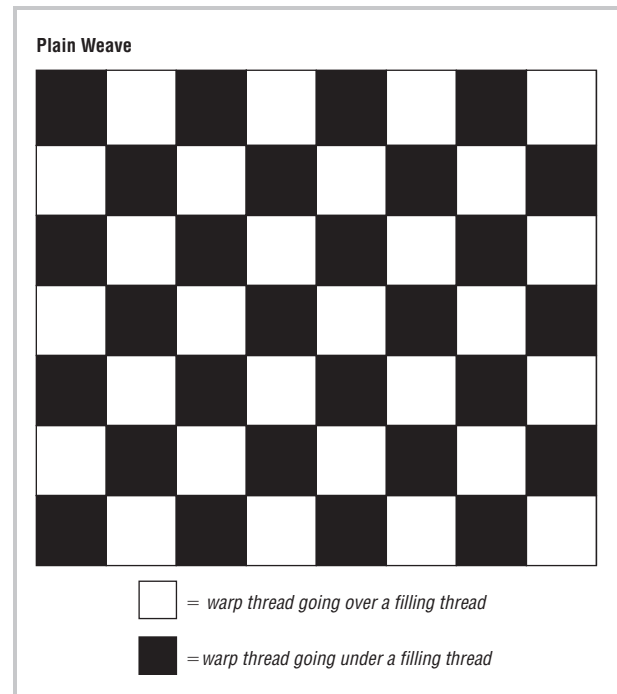

**Plain weave.** The most basic structure for producing cloth, the plain weave technique is known to have been in use as long ago as the Late Stone Age.

### BIBLIOGRAPHY

- Encyclopedia of Textiles*. 3rd ed. Englewood Cliffs, N.J.: Prentice-Hall, Inc., 1980.
- Kadolph, Sara J., and Anna L. Langford. *Textiles*. 9th ed. Upper Saddle River, N.J.: Prentice-Hall, Inc., 2001.
- Tortora, Phyllis G., and Robert S. Merkel, eds. *Fairchild's Dictionary of Textiles*. 7th ed. New York: Fairchild Publications, 1996.

Heather Marie Akou

**WEAVE, SATIN** Along with plain and twill weave, satin is one of three basic weave structures that have been in use since ancient times. Associated with luxury, romance, and sensuousness, satin and sateen fabrics are made of fine silk and cotton yarns as well as manufactured fibers such as rayon, acetate, and polyester. Satin weaves have a smooth, lustrous surface and possess the best draping qualities out of all the weave structures. The pattern of a satin weave is similar to a twill, but the floats (yarns that go over multiple warp or filling yarns before they dip under the surface) are very long—covering up to eleven other yarns. Satin must be woven on a loom with at least six (and more commonly eight) harnesses. Instead of having diagonal lines, the floats are usually staggered to make the surface look as smooth and seamless as possible. This property is enhanced by packing the floats very close



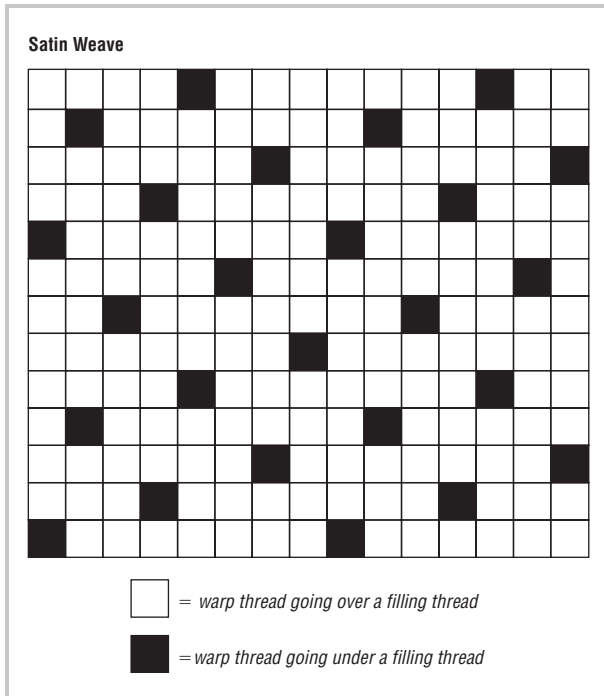

**Satin weave.** The staggered floats in the satin weave help to create a seemingly smooth surface, with a structure that can be difficult to see even under magnification.

together. Even under magnification, it can be difficult to see the structure of a very tight satin weave.

### A History of Satin Weaving

Until the invention of manufactured fibers, satin fabrics were generally expensive to produce because they required large quantities of silk or very fine cotton yarns. (With yarns any thicker, the floats would be so long that the cloth would be too fragile to wear.) In the mythology surrounding silk weaving, the original source of the name for satin has been lost. One suggestion is that it comes from the ancient Chinese port of Zaytoun. Another is that satin was “called *sztum* until the Renaissance; then the Italian silk manufacturers changed the term to *saeta* to imply *hair* or *bristle*, a term which can be applied to fabrics of this type since they show a hairline and glossy surface” (American Fabrics, p. 198).

Satin weaving was invented in China more than two thousand years ago. Although elaborate textiles such as brocade (a figured satin produced on a draw loom) were expensive and in many cases restricted to the upper classes, the cultivation of silk was widespread. By the late second millennium B.C.E., “Ordinary peasant women were expert in the special techniques associated with silk weaving; silk was produced in quantity and worn, at least on some occasions, by a wide range of people, not just the aristocracy” (Steele and Major, p. 22). Silk weaving was a treasured secret, but eventually the technology

spread to Japan, Korea, India, Thailand, and other parts of southern Asia. Limited amounts of silk fabric were exported to the West as early as the time of ancient Greece, but satin was not produced in Europe until the Middle Ages. The scarcity of silk restricted the use of this material to the church, nobility, and upper classes.

During the late Renaissance, silk weaving expanded from Italy to Spain, the Netherlands, France, England, and the American colonies. Variations of satin acquired several new names including *peau de soie* (literally “skin of silk,” a matte fabric with tiny diagonal lines) and *charmeuse* (a lightweight, pebbly satin, sometimes called crepe-backed satin). *Sateen*, made of finely spun cotton threads (often long-staple Egyptian cotton), has floats in the filling instead of the warp. These sideways floats drape in the opposite direction from a standard warp satin; when used for an elegant ball gown or full skirt they help the fabric stand away from the body. Slipper satin, a strong, compactly woven material is mainly used for footwear.

### Uses of Satin in the West

Modern uses of satin in the West have been sacred and profane—it has been sewn into everything from bridal gowns, ballet slippers, and evening dresses to sexy corsets and lingerie. A contemporary book, *The Wedding Dress*, describes “silk, tulle, satin and lace” as the “heart of a romantic dream” (McBride-Mellinger, p. 9), but satin was not commonly used in bridal gowns until the late 1800s. Because the long floats on the surface of this fabric are easy to snag, it can be difficult to maintain the appearance of satin through repeated use. This was the first time that women outside of the upper classes could afford the luxury of a dress worn only for a single day. Before that time, dresses were used over and over again as “Sunday best.”

As manufactured and synthetic fibers such as rayon (originally called “artificial silk”), acetate, and polyester were invented beginning in the 1920s and 1930s, satin gradually became available to an even larger number of women. Duchesse satin, a blend of rayon and silk, was invented as a less expensive, lightweight alternative to 100 percent silk satin. In the early 2000s, all varieties of satin are used for bridal gowns and bridesmaid dresses, evening gowns, prom dresses, and accessories at many different levels of price and quality.

Satin also made an appearance in the late 1800s in the undergarments of fashionable Parisian women. The sensuousness of satin—a prelude to the nude body underneath—was considered very erotic. Although colorful satin was first associated with prostitutes, “fashion journalism and advertising increasingly emphasized the importance of luxurious and seductive lingerie, including colorful, decorative corsets” (Steele, p. 133). In the early 1900s, satin became popular in other styles of lingerie as corselettes, girdles, brassieres, and panties were accepted as replacements for the petticoat and corset. “By 1910,

brassieres were available in cotton tricotine [a knit fabric], silk, satin; in 1920 *Vogue* advertised one in tulle; and in the 1930s sateen was particularly popular” (Carter, p. 89). New materials such as rayon, nylon, and polyester made it possible for women from nearly all walks of life to purchase sexy lingerie. These fabrics were rationed during World War II, but advertisements and pin-ups pictured women dressed in lustrous satin camisoles.

Satin has continued to be very popular. In the 1970s, the corset came back into fashion as members of punk and goth subcultures “began to reappropriate the corset as a symbol of rebellion and ‘sexual perversity’” (Steele, p. 166). In her “Blond Ambition” tour in the early 1990s, Madonna wore a light pink satin corset designed by Jean-Paul Gaultier. An obvious symbol of her sexuality, the corset was not only flaunted as outerwear but had padded, cone-shaped breasts. Partly for reasons of nostalgia, these styles have come back into high fashion at the beginning of the twenty-first century.

See also **Cotton; Polyester; Rayon; Silk; Weave, Plain; Weave, Twill; Weave Types; Wedding Costume.**

#### BIBLIOGRAPHY

- American Fabrics and Fashion editors. *Encyclopedia of Textiles*. 3rd ed. Englewood Cliffs, N.J.: Prentice-Hall, Inc., 1980.
- Carter, Alison. *Underwear: The Fashion History*. London: B.T. Batsford, Ltd., 1992.
- McBride-Mellinger, Maria. *The Wedding Dress*. New York: Random House, 1993.
- Steele, Valerie. *The Corset: A Cultural History*. New Haven, Conn.: Yale University Press, 2001.
- Steele, Valerie, and John Major, eds. *China Chic: East Meets West*. New Haven, Conn: Yale University Press, 1999.

Heather Marie Akou

**WEAVE, SLACK TENSION** Slack tension weave is part of a family of weaves that rely on a variation in tension between top and bottom sheds to produce design effects on the surface of fabrics. Broadly speaking, terry, plisse, and pile fabrics fall within this definition, but other many other fabrics make use of the principle as well.

Fabric formation by weaving requires a tension balance between the top and bottom sheds of the warp prior to warp insertion. Common fabrics such as many twills, satins and plain weave variants utilize differences between top and bottom shed tensions to produce more dramatic face or back effects on a fabric surface. These types of shed geometry variations are sometimes colloquially known as “weaving in a sack” because the tension differences are reminiscent of a sack held open at the top while the bottom is allowed to be slack.

Slack sheds are produced by a smaller displacement from the horizontal or closed shed position by one shed

opening than the other. Usually it is the top shed that is allowed to be slack while the bottom shed is held tight. The limiting factor to the tension in the tighter shed may be determined by one of two rules. In the first rule, the tightest shed may be no more than 10 percent tighter than the base tension of the warp during closed shed. By the second rule, the individual ends of the tighter shed should bear no more than 15 percent of the average single end break load of that warp yarn type.

Within the initial modulus region of the yarn’s load-elongation profile, there is direct proportionality of the yarn tension to the shed opening angle. That tension or load may be determined either by dividing the base warp tension at closed shed by the cosine of the appropriate opening angle or it may be found by using the Pythagorean theorem to find the yarn extension during opening. It is important to note that the opening point of the rear shed is determined by the position of the stop motion and not by the whiproll of the weaving machine.

Since warp let-off is governed by reaction of the whiproll or tensioner rolls, the slack shed is advanced by the same length as that demanded by the more heavily loaded shed. As a result, longer floats are generated in the fabric than would be present in symmetrical shed weaves. These long floats create structural variations on a fabric surface that are utilized by designers to produce billows, waves, rows and similar textures.

Other variants of slack shed weave designs require the use of multiple warps advancing at different rates from different warp beam let-off systems on the same machine to produce pile and loop effects on the surface of a fabric. Such systems require exact feed measuring for the warps and often require variable beat-up systems to compact the picks into a warp of deliberately varying lengths.

See also **Loom; Weave, Double; Weave, Pile; Weave, Plain; Weave, Satin; Weave, Twill; Weaving; Weave Types; Weaving, Machines.**

#### BIBLIOGRAPHY

- Emery, I. *The Primary Structures of Fabrics*. Washington, D.C.: The Textile Museum, 1980.
- Gioello, D. A. *Profiling Fabrics: Properties, Performance, and Construction Techniques*. New York: Fairchild Publications, 1981.

Howard Thomas

**WEAVE, TWILL** Twill is an ancient weaving technique used to produce durable fabrics that have characteristically diagonal patterns called “wales.” Twill fabrics are woven on looms using three or (more typically) four harnesses—frames with “heddles” (loops of string or wire) that hold individual warp yarns in place and are used to lift up every third or fourth warp yarn in a repeated pattern. On a four-harness loom, the weaver can

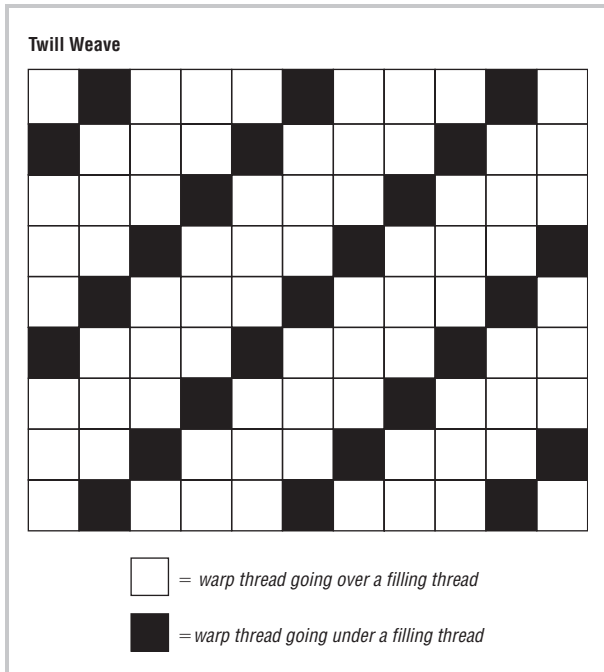

**Twill weave.** The twill weave technique produces fabrics that are stronger, thicker, and more durable than those made by other techniques. This is largely because the filling and warp yarns interlace less frequently.

alternatively lift up sets of two harnesses at once (1+2, 2+3, 3+4, ...). This creates an even sturdier and more balanced twill weave.

Because the filling and warp yarns in a twill weave do not interlace as many times as they do in a plain weave, the yarns can be packed more tightly together. This makes the fabric stronger, thicker, and better able to hide soil than a plain weave made from the same materials. It also gives the fabric a better drape and resistance to wrinkling. Lightweight twills are commonly used for dresses, scarves, and neckties. Heavier weights are used for blue jeans, jackets, and outerwear for work such as carpentry and construction. Elegant variations of twill weave, including houndstooth and herringbone, are used for high-quality professional clothing.

### Basic Twills

Lightweight twill fabrics for men's neckties are commonly called foulard or surah. Foulard is literally the French word for a necktie or scarf. These fabrics are made of silk or a manufactured material such as polyester. They can also be used for lingerie, slip dresses, or linings in other garments. Although the fabric is thin, the strength of a twill weave makes the final product fairly durable. Challis is a light- to medium-weight twill made of wool or rayon. This fabric has a luxurious drape, is resistant to wrinkling, and is often used for women's apparel.

A heavier twill known as serge has a smooth surface and is frequently used for stylish outerwear such as trench coats. Thicker versions made of wool and cotton are used for work clothing. Serge de Nîmes (serge from the city of Nîmes in southern France) was, some argue, the original name of denim, the heavy cotton twill now used for blue jeans. Levi Strauss, the inventor of blue jeans, was initially using tent canvas (a plain weave), but switched to denim because of its superior strength. For similar reasons, in 1908 the U.S. Army began to issue soldiers denim work uniforms. These were popular and widely used until they were phased out during World War II.

Denim generally has blue cotton yarns (dyed with indigo) in one direction and white cotton yarns in the other direction. A cheaper version can be made by substituting polyester for the white yarns.) This color difference emphasizes the diagonal wales of the cloth and gives denim its characteristically worn look. Trendier versions of denim can be woven with other colors of thread or dyed later as a whole garment. The strength of denim allows the garment to undergo harsh finishing treatments such as acid- and stonewashing, abrasion, and slashing. A lighter fabric that looks very similar is known as jean and is often used for casual button-down shirts, children's clothing, and home furnishings.

Other twill weaves that are frequently made into work clothing include drill (a heavy cotton fabric), cavalry twill (a smooth wool fabric with distinct diagonal lines), and chino (a relatively lightweight cotton fabric). Chino had its origins as a material for summer-weight military uniforms during World War I. Popularized by "casual Fridays" as well as Gap advertisements in the late 1990s, chino became a popular choice of fabric for casual pants, capris, and skirts. It was also part of the "Ivy League look" in the 1950s and early 1960s. Gabardine, an elegant material made from wool instead of cotton, is a common choice for professional suits and dress slacks. This fabric has distinct diagonal wales created by using many more warp threads per inch than filling threads. Different colors of thread in the warp and filling, such as brown and camel, can emphasize these lines further.

### Variations

As with plain weave, there are many ways to alter the structure and appearance of a twill weave. Houndstooth is a classic twill fabric with a small, distinctive pattern that looks like a four-pointed star. This is created by alternating two different colors of warp and filling threads, often black and white to emphasize the pattern. Herringbone twills have diagonal lines that periodically change direction, creating zigzag patterns that look like subtle stripes from a distance. This pattern is made by changing either how the harnesses are threaded or the order in which they are lifted. Herringbone twills are generally made from smooth, medium-weight wool yarns and are used for professional clothing.



Other decorative twills that do not have specific names are called broken twills, pointed twills, or undulating twills. These patterns are created by using more harnesses and more complex systems of threading and of lifting the harnesses. Textile designers have an almost unlimited number of ways to change a twill pattern. These fancy twills are not very common and are generally used for either expensive home furnishings or couture apparel.

See also **Cotton; Denim; Gabardine; Indigo; Jean; Levi Strauss; Neckties and Neckwear; Polyester; Rayon; Silk; Weave, Plain; Weave, Satin; Wool.**

#### BIBLIOGRAPHY

- American Fabrics and Fashion editors. *Encyclopedia of Textiles*, 3rd ed. Englewood Cliffs, N.J.: Prentice-Hall, Inc., 1980.
- Emerson, William K. *Encyclopedia of United States Army Insignia and Uniforms*. Norman: University of Oklahoma Press, 1996.
- Finlayson, Iain. *Denim: An American Legend*. New York: Simon and Schuster, Inc., 1990.
- Kadolph, Sara J., and Anna L. Langford. *Textiles*. 9th ed. Upper Saddle River, N.J.: Prentice-Hall, Inc., 2001.
- Oelsner, G. Hermann, and Samuel S. Dale, eds. *A Handbook of Weaves*. Mineola, N.Y.: Dover Publications, 1990. Original edition published in 1875.

*Heather Marie Akou*

**WEAVE TYPES** Names given to fabrics differ depending on who is naming them. One only has to walk through a museum collection and read the labels, to find out that even within the same institution, there is often no agreement on how to categorize a cloth. At different times, lampas, diasper, and tissue have all been used to describe the same type of cloth. Depending on when or who entered the piece into a collection, the label will reflect the terminology of that period. This can be confusing when one is standing next to two fabrics that appear to be similar, but have different labels (i.e., lampas for one and diasper for the other).

In a different textile circle, contemporary hand weavers might be heard talking about weaving using the Theo Moorman technique. The listener won't know, as the weavers themselves might not know, that this structure is identical with lampas, diasper, and tissue. Theo Moorman had the awareness to state that she suspected her technique had been used elsewhere, but since she didn't know where or when, it was not unreasonable for her to call it her own technique. Sometimes the magazines for handweavers have quite imaginative names for types of weaves that are invented by the authors, based only on their own sense of labeling.

The confusion increases when one looks at magazines and articles for the fashion or interior design market, where names are often created for marketing strategies rather than for clarification of terms. Marketers

often want to obscure the facts, making something very mundane appear exotic. It is much more exciting to label a cloth as microfiber than it is to remind the public of the negative connotations of polyester, even though they are, in fact, the same.

So it is important to realize that different constituencies in the world of textiles will use different labels for cloth. Even when the same word is being used, it may have a different meaning, depending on the viewpoint and education of the speaker. An interior designer might speak to another designer using the word "tapestry" to describe a wall hanging, and they understand they are discussing a pictorial textile, not necessarily referencing how the work was made. A weaver, however, who thinks in terms of weave structure for classification, overhearing their conversation, might take exception to this usage, unless the work being discussed was specifically a weft-faced plain weave using discontinuous wefts to create the pictorial elements. Thus, it is important to recognize that the classification of weave types reflects the needs and concerns of the group using the terms.

#### Codifying Weave Types

Perhaps textile historians, archaeologists, and curators are the most rigorous group trying to codify and clarify the labeling of weave types. After all, their need for clear communication is critical; their research is used by others, and perhaps spurs on further research. Thus textile scholars began an international movement to standardize terminology through the establishment of the Centre International d'Etude des Textiles Anciens (CIETA) in 1954. If one attends a symposium of scholars presenting papers on woven textiles today, or reads an exhibition catalog for a contemporary exhibit of historical textiles, most of the classification will try to follow the conventions of CIETA.

Another influential study on textile classification is Irene Emery's *The Primary Structures of Fabrics*, first published in 1966. Although she covers more than woven cloth, most of the book is focused on the structural classification of weaves (not on the process of making). Weaving falls under the heading of constructions using two or more elements, composed of the interlacement of vertical (warp) elements and horizontal (weft) elements. With concise language, clarified by magnified photographs of the structures, Emery details plain weave, float weaves, compound weaves, crossed-warp structures (gauze), twining, and weft wrapping.

Since Emery limits her discussion to structure, she does not include fabric names, which can take into account other characteristics such as fiber, color, finish, and texture. This type of classification, however, is critical to the worlds of fashion design and interior design. Thus taffeta, poplin, grosgrain, cheesecloth, ottoman, and broadcloth are just a few of the varieties of cloth sharing the same weave structure (plain weave), but each evokes



A weave draft documents the different components of a specific woven cloth. A diligent weaver can express, diagrammatically, all the pertinent information for another weaver to exactly re-create their fabric. Written for a shaft loom, these elements include the threading draft, which records the sequence used for threading each warp thread in a shaft; the tie-up, which records what shafts are connected to each peddle of the loom; the sequence of treadling, which documents the order in which the peddles are used; and the cloth diagram, which is the sum of the parts, and is another term for the weave structure. (The draft for a dobby loom assumes a direct tie-up [as if one shaft is tied to one peddle] and the ability to raise multiple shafts. The draft has one area called the liftplan, which combines the information that tie-up and treadling sequence give for a shaft loom.) Diagrams can also include the color sequence used for both warps and wefts; notations of different sizes of yarn used; and notations for denting instructions (how threads are clumped in the reed).

a distinct fabric with specific characteristics for the designer who uses these names. Cheesecloth is very open and soft (more open than gauze), and is a balanced plain weave, while broadcloth is of medium-weight with a ribbed effect caused by the warp being more dominant than the weft. These names can also refer to specific yarns being used; for example, taffeta is traditionally made with filament yarns and is very shiny, while broadcloth is traditionally made from cotton or a cotton blend.

### Weave Types by Structure

The term weave structure refers specifically to the interlacement of the vertical and horizontal elements in a weave. As the vertical element, the warp, traverses the cloth, it dives over and under the horizontal element, the weft. Conversely, one can speak of the path the weft takes, moving over and under the warp ends, as it travels horizontally across the cloth. Structural diagrams of cloth can show slices of the cloth, depicting the paths of warp and weft in three-dimensional diagrams called cross sections. These diagrams are particularly helpful to remind the weaver that cloth, usually thought of as a flat, pliable plane, is really a three-dimensional form. More often, though, the diagram of a weave structure is rendered as a two-color grid format. Combined with other information needed to recreate the cloth, this diagram is called a weave draft.

The three most well-known categories of weave structure, using one warp system and one weft system, are plain weave, twills, and satin weaves. Each has a dis-

tinct type of interlacement that distinguishes it from the others. The path of a warp in plain weave is always over one weft, under one weft. The path of a warp thread in a twill can vary (for example, a 2,2 twill goes over two wefts and under two wefts, while a 5,3 twill would go over five wefts and under three), but it always has adjacent warp threads, in either the right or left direction, lifting, and following the same sequence of over and under. This causes distinct diagonal lines in the fabric. Satin structures, however, never have adjacent ends (warps) go under the same weft, and their appearance is of a smooth, unbroken surface.

These three weave types have been used throughout the history of textiles in all parts of the world. Whether on backstrap looms, draw looms, or floor looms, the majority of textiles created have used one of these three structures. Of course the sett of the warp (the density of the warp), the type of yarn used, the color of the warp and weft threads, and the texture of the yarn will affect the look of the fabric, and thus the classification of fabrics by name.

**Weave structure can look different in the cloth.** Since all weave structures can be modified in appearance through changes in sett, or yarn size, or color, using weave structure as the classification for weave type only tells part of the story.

**Compound weave types.** Weaves can also be classified in terms of dye processes done to the warp—thus ikat textiles, or painted warp textiles. Or they can be classified by finishing processes, such as fulled, felted, or shrunk; or stamped, incised, or watermarked. Whatever the classification, if one looks carefully, one can probably find a different name for the same weave type some time during the long and varied history of textiles.

See also **Polyester; Tapestry; Weave, Plain; Weave, Twill.**

### BIBLIOGRAPHY

- Burnham, Dorothy K. *Warp and Weft*. New York: Charles Scribner's Sons, 1980.
- Emery, Irene. *The Primary Structures of Fabrics*. Washington, D.C.: The Textile Museum, 1966.
- Collier, Billie J., and Phyllis G. Tortora. *Understanding Textiles*. Upper Saddle River, N.J.: Prentice Hall, 2001.
- Grosicki, Z. *Watson's Textile Design and Colour*. London: Newnes-Butterworths, 1975.
- . *Watson's Advanced Textile Design*. London: Newnes-Butterworths, 1989.
- Kadolph, Sara J., and Anna L. Langford. *Textiles*. Upper Saddle River, N.J.: Prentice Hall, 2002.
- Moorman, Theo. *Weaving as an Art Form*. West Chester, Pa.: Schiffer Publishing Ltd., 1975.
- Oelsner, G. Hermann. *A Handbook of Weaves*. Translated and revised by Samuel S. Dale. New York: Dover Publications, Inc., 1952. Original edition was published in 1915.

van der Hoogt, Madelyn. *The Complete Book of Drafting for Handweavers*. Coupeville, Wash.: ShuttleCraft Books, 1993.

*Bhakti Ziek*

**WEAVING** Weaving, one of the oldest technologies practiced by humans, is the interlacement of two or more vertical and horizontal elements. The result of this action is that the individual elements form a shallow three-dimensional plane, which is usually flexible. In its simplest form, known as plain weave, the first warp (the vertical element) goes over and under each weft (the horizontal element); the second warp goes under and over each weft; and this sequence is repeated throughout the cloth. When the warp and weft are similar in size, and show up in equal amounts in the fabric, the cloth is known as a balanced plain weave. However, the scale of the elements and their density can vary, creating fabrics that show more warp or more weft.

The path that the interlacement of the threads takes can also vary. Weavers, historians, and others interested in weave structure, have developed systems for describing the various forms of interlacement—plain weave, twills, satins, and double cloth are some of the most common families of weave.

The first weavings were probably done through manual manipulation of the elements. Mat weavers in Nepal still create products using their hands and working on the ground. Looms were developed in all parts of the world to make the process of weaving easier and quicker. A loom holds the vertical warp threads under tension so the weft threads can be inserted with ease. The pot-holder loom that children use is such a device. The wefts are then inserted by manually going over and under the tensioned warps. Eventually looms were modified to aid the separating of the warp threads so the weft could easily be inserted in the resulting triangular space, known as the shed.

In most instances, when looking at a woven cloth, one will see the warp and weft crossing each other in a perpendicular manner. There are structures, however, where the 90-degree intersection is modified and leans one way or another, such as in the group of weaves known as deflected warp or weft. There are other processes that make planes of cloth, such as beating bark fibers or meshing animal fibers together (felting), that do not have the interlacement of elements found in weaving. Even when woven cloth is modified (shrunk and matted in a process called fulling or felting) until it loses the appearance of interlacement, the structure is still embedded in the fabric.

Some planes of fabric are made through the looping of single elements, using processes such as crochet, knit, and knotting. There are other two-element processes (including plaiting or braiding, macramé, and twining,) that differ from weaving in the manner of the interconnection of their elements.

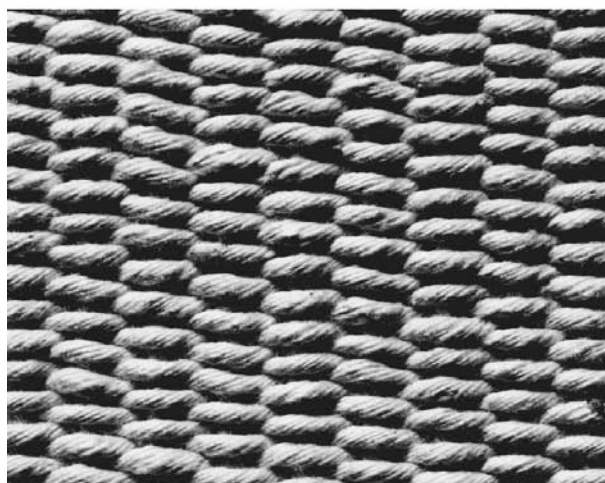
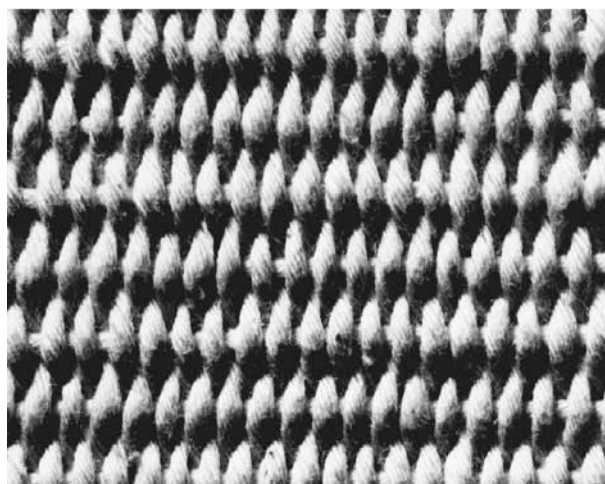
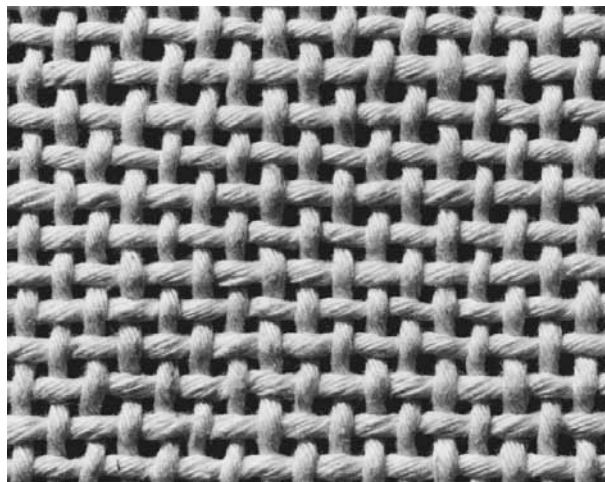

**Weave types.** *Top:* Balanced plain weave, warp and weft equal in size, spacing and count. *Center:* Warp-faced plain weave. *Bottom:* Weft-faced plain weave. PHOTOGRAPHS OF BALANCED, WARP-FACED AND WEFT-FACED PLAIN WEAVE FROM THE PRIMARY STRUCTURES OF FABRICS, BY IRENE EMERY, WASHINGTON, D.C.: THE TEXTILE MUSEUM, 1966, FIGURES 85, 86, 87, PAGE 76.



Weaving, which can have more than one vertical or horizontal element, usually results in a plane of fabric that looks two-dimensional, but is actually a three-dimensional form. The strength and flexibility of this plane make it perfect for creating clothing, shelter, and furnishing fabrics. In recent times it has also been used as an art form.

See also **Loom; Weave, Plain; Weave, Twill; Weave, Satin; Weave Types; Weaving, Machinery.**

#### BIBLIOGRAPHY

- Burnham, Dorothy K. *Warp and Weft*. New York: Charles Scribner's Sons, 1980.
- Emery, Irene. *The Primary Structures of Fabrics*. Washington, D.C.: The Textile Museum, 1966.
- Oelsner, G. Hermann. *A Handbook of Weaves*. Translated and revised by Samuel S. Dale. New York: Dover Publications, Inc., 1952. Original edition was published in 1915.

*Bhakti Ziek*

**WEAVING MACHINERY** The history of mechanization in the weaving industry is replete with stories of inventors whose ideas were untimely or impractical. The perseverance of inventors is a testimony to the importance of cloth in our culture and of the lucrative nature of the business. Mechanization of the weaving process began in earnest in the eighteenth century. Prior to developments in automation, one weaver was needed to operate one loom, and an assistant was necessary if a complex pattern was being woven. There were a few developments prior to 1700, but none of significance or permanent influence. One problem that inventors faced was violent opposition from textile workers who resented any innovations that would speed an individual's production capacity and therefore reduce the numbers of weavers needed. Improvements in the speed of weaving during the eighteenth century were given impetus by the invention of spinning machinery for the production of yarn necessary for weaving. Until mechanical spinning came into use, the output of three to four spinners was necessary to keep one weaver fully employed. Acceptance of advances in loom technology was also aided by continuing improvements in spinning and cloth finishing technologies. The first significant move toward automated weaving occurred when John Kay invented the flying shuttle in 1733. The flying shuttle was set in motion by the weaver pulling a cord or handle that propelled the shuttle across the width of the textile. Not only did this speed weaving by as much as four times, it also allowed a weaver to produce cloth wider than his arm's reach.

In 1785, a clergyman named Edmund Cartwright patented the first power loom. It was initially powered by an oxen, then by the new steam engine patented by James Watt in 1769. Cartwright's loom was slow to be accepted, but by the 1830s versions of his loom enabled

one weaver and an assistant to operate four looms simultaneously. This machine was limited to producing plain textiles.

The automation of patterned fabric production began with the 1804 invention by Joseph Marie Jacquard. His so-called Jacquard mechanism could be mounted on any loom and controlled the lifting of the warp yarns that create the fabric's pattern. Previously, complex patterns had to be set up in advance on a loom and required an assistant to operate, but the Jacquard attachment allowed one weaver to control the shuttle and the pattern mechanism alone. Punched cards controlled the lift of the warp pattern yarns and a design could be changed very quickly by changing the punch cards that correspond to a particular design. This basic system remains in use in the early twenty-first century.

In 1835 the first automatic shuttle change machine enabled weft yarns of different colors to be inserted automatically in the weaving. 1895 saw the invention of the automatic pirn (weft supply) change in the shuttle, introduced by J. H. Northrop. Not until the 1950s did automatic weft winding directly on the weaving machine become commercially viable. It was introduced by the Leesona Company and known as the "Unifil" system.

Shuttleless looms appeared in the mid-twentieth century and employed various systems: grippers, rapier, and jets of water or air. Gripper machines use a small projectile that picks up a weft from a supply on the side and carries it to the other side; rapier machines use a long thin rod which travels from one side and grabs a weft which it pulls across as it returns (there are single and double rapier looms; the double rapiers meet in the center and pass off the weft thread); jet looms use a jet of air or water to propel the weft from side to side. Jet looms have the advantage of being particularly fast and can weave widths up to 85 inches. The rapier loom has the oldest history as the concept appears in a patent of 1678; the modern rapier loom was launched in 1963 by Dornier of Germany. A forerunner of the modern air jet loom first appeared in England in the 1860s, but the idea was finally commercially successful in the 1950s, introduced by Max Paabo of Sweden. The projectile (gripper) loom was invented in Switzerland by the Sulzer Brothers in 1924 but did not come into commercial use until 1953.

Fabrics from shuttleless looms do not have a selvage, as the weft is not a continuous yarn. The edges can be sealed with heat or resin. Until recently, these machines were limited to high volume weaving. Shuttle looms are still used for weaving basic constructions in low-wage economies and for specialist fabrics, which still comprise a large part of the market.

In the 1970s, the multiphase loom, in which all the actions of the loom take place simultaneously, was introduced. There are two types of multiphase looms: wave shed looms, in which the shed changes across the width of the textile as the weft travels, and parallel shedding, in

which multiple sheds are formed along the length of the warp. One of the latest multiphase looms can produce 1.5 yards of fabric in one minute. In the early 1980s, computer-aided design and manufacture (CAD/CAM) became available and the design process, which could take weeks or months could be shortened drastically to as little as a twenty-four-hour period, if necessary. Computer generated design samples can also replace actual woven samples and can therefore be produced almost immediately and transmitted electronically to any point on the globe. This technology has also enabled designers to become partners in the manufacturing process, as changes can be introduced “virtually” without the cost of loom set-up and production time. Computers can also monitor the weaving process itself and can detect and automatically correct numerous mistakes.

Currently, designers have the possibility of working directly on systems where designs created on a computer screen are transferred directly to the controls of a computerized loom with the corresponding technology. The reaction to CAD/CAM has been mixed, as the ease of technology can lead to a disintegration of design.

See also **Loom; Weave, Double; Weave, Jacquard; Weave, Pile; Weave, Plain; Weave, Satin; Weave, Slack Tension; Weave, Twill; Weave Types; Weaving.**

#### BIBLIOGRAPHY

- Benson, Anna, and Neil Warburton. *Looms and Weaving*. London: Shire Publications, Ltd., 1990.
- Braddock, Sarah, and Marie O'Mahony, eds. *Textiles and New Technology: 2010*. London: Artemis Verlag, 1994.
- Broudy, Eric. *The Book of Looms: A History of the Handloom from Ancient Times to the Present*. New York: Van Nostrand Company, 1979.
- Kadolph, Sara. *Textiles*. Upper Saddle River, N.J.: Prentice Hall, 2002.
- Omerod, A. *Modern Preparation and Weaving Machinery*. London: Butterworths, 1983.
- Price, Arthur. *J.J. Pizzuto's Fabric Science*. New York: Fairchild Publications, 1994.

Melinda Watt

**WEDDING COSTUME** A wedding dress is apparel used in conjunction with wedding ceremonies, including accessories that may differentiate nonmatrimonial dress from that worn specifically for weddings.

#### Contemporary Overview

As of the late twentieth and early twenty-first centuries, the global, urbanized standard of wedding apparel has followed the Western tradition of a bride dressed in white or off-white, with a head-covering, whether a veil or headpiece, and carrying flowers, a book, or some other object. The groom is attired in keeping with the degree of for-

malty of the bride. Attendants are generally present, the number, gender, age, and dress of whom being peculiar to each culture. Family members usually attend, playing a prominent role, and are dressed in equally formal, but generally more subdued styles of clothing than the bridal party. Other accessories have become standard, some of which are mandated by religion or culture, and others of which are remnants of folk practice. The former may include specific types of headgear, for both bride and groom, and possibly all attendees. These range from yarmulkes at Jewish weddings, to crowns held over the heads of the bridal couple in Orthodox Christian ceremonies. Anglophone folkloric touches suggest the inclusion of “something old, something new, something borrowed, and something blue,” as well as a single garter, a remnant of the days when the public removal of one’s garters was a significant symbolic gesture. The throwing of the garter to the male attendants serves more or less the same function as the tossing of the bridal bouquet to the females: that of determining the next to wed, although the previous stipulation that all attendants be unmarried having disappeared, this old “good luck” charm is vitiated.

In contemporary non-western industrial societies, the situation is complex. There are generally local or national traditions, based on religious and/or societal norms that have developed over time to provide identifiable wedding apparel. This can range from Japanese kimonos to long body- and face-concealing robes in Islamic cultures, to elaborate saris in India, to hand-embroidered and metal-encrusted Hmong dress. However, the primacy of the “western wedding style”—that of a bride dressed in a white gown and a groom in typical western formal attire, has supplanted many local traditions, at least for the middle and upper classes. Even in countries with strong local traditions, if there are no specific religious strictures that would prohibit them and the economic resources are available, couples may opt to hold two ceremonies, one in the tradition of their own country and one of the western variety. This has been particularly popular in Japan and Korea, where the couple dresses according to the religion and architecture of the wedding chapel, or holds two separate ceremonies, and might change ensembles five to seven times during the course of the celebrations. Even in Islamic societies such as Saudi Arabia, this doubling up of wedding attire has proven popular among the upper classes.

#### History

It is not possible to determine from archaeological evidence whether or not prehistoric societies celebrated marital unions in a specific manner or marked those celebrations through the use of special garb. Information is nearly as scarce for the first great urban societies, where nothing is known of the wedding dress or practices of the bulk of the population and only dynastic marriages survive in the written record. However, it appears that even at the dynastic level, dress for weddings was

less occasion-specific than a matter of showing off one's best garments and accessories.

The first clear references to specific wedding apparel, in the form of bridal crowns and veils, come from the Hellenistic period of Greece. These too, while specified for use in weddings, and ranging from simple flowers to elaborate metal tiaras, were accessories. It is not until many centuries later that most cultures adopted recognizable ensembles to mark the occasion. This stems, in part, from simple economics. In pre-industrial times, the idea of ceremony-specific clothing, particularly for a one-time event, was beyond the means of the vast majority of the population. Even at the court level, wardrobe inventories discuss the fact that royalty and courtiers alike tended to wear their most fashionable garments, with no real consideration of one-time use or symbolism of color or style. Again, it is the use of accessories that gives the garments their meaning.

It was during the long rule of Queen Victoria (1837–1901) that the Western notion of what the bride and her party should look like solidified, first in Britain, and subsequently the rest of the industrialized world. However, certain aspects, such as identically dressed attendants, appeared in many other cultures for more symbolic reasons than simply to honor, support, and, perhaps impress. The generation previous to Queen Victoria's introduced the white wedding gown, when Victoria's cousin, Crown Princess Charlotte, was married in 1816. According to reports, and a controversial garment in the collection of the Museum of London, her bridal gown consisted of a silver tissue and lace overgown worn over a white underdress. That this probably had more to do with the Regency fashion of white dresses than any symbolic intent did not stop it from exerting the same fashion influence of twentieth-century "royalty" such as Princess Grace of Monaco; Diana, Princess of Wales; or Carolyn Bessette Kennedy. The ideal of a white wedding dress was codified in 1840, when Queen Victoria wore a creamy white Spitalfields silk satin and lace gown. It was endlessly reproduced in fashion journals, setting a fashion standard for some appreciable time.

With the advent of industrialization in the West, the combination of readily available and comparatively cheap fabric meshed with the aspirations and needs of a no-longer self-sustaining population to acquire more garments, particularly those for festive occasions. Improved communication, in the form of newspapers, magazines, and their delivery methods of roads, railroads, and improved shipping speeds, as well as the establishment of dependable rural postal delivery at the turn of the twentieth century, allowed even isolated or working-class women to aspire to new fashion trends. However, economics and practicality continued to play a significant role, particularly among these populations. Societal norms decreed that appropriately formal dress be worn for significant occasions, from confirmation, to weddings, to church attendance, to funerals. Frequently, such a dress

was presented to a young woman at her coming of age; if funding permitted, another was obtained for her wedding. However, this dress would be expected to serve, not only for the festive occasion for which it was purchased, but also for all others in the foreseeable future, including funerals. It tended toward a conservative cut for this reason, and often had large seam allowances that could accommodate pregnancy and possible weight gain. With the long-standing tradition of black for funerals and mourning, most of these "good" dresses were black, and often worn for the first time at the woman's wedding. This tendency continued into the late nineteenth and even early twentieth century among rural women. Women of the higher classes wore colors; frequently, but not invariably, white. After a death in the family, when the period of strict mourning was over, marriage could take place, but the bride would wear either gray or lavender. Among the working classes, as soon as it was economically feasible, colors were adopted, although the white, one-time only dress was still a rarity. Even the more affluent often assumed their gowns would see use more than once, and colored wedding dresses were still common into the first decade of the twentieth century, after which the ideal of a white, often anachronistic gown, meant to be worn only once, was only supplanted by extraordinary conditions, such as war.

With nods to changes in silhouette and length, the now-immutable tradition of the bride in white, surrounded by equally formally dressed family and attendants, became the norm, not only in Western culture, but wherever Western fashion was emulated, and frequently in the face of centuries-old local tradition. Occasional vagaries of lifestyle, including nude hippie weddings and thematic concoctions ranging from period or folk evocations to camouflage in honor of a deploying soldier, did not dislodge the basic formal make-up of the wedding party, or its concentration on white or off-white and a fairly conservative cut. However, in the 1980s, this began to change, first among the attendants and guests, who began to wear colors such as black, previously considered taboo for twentieth-century weddings. New materials began to appear, including leather, sequins, and even tattoos, as part of the wedding ensemble which itself frequently displayed significantly more flesh than had previously been considered appropriate. Now even brides were sporting colors such as red and black, and indeed, even getting tattoos for the occasion.

The symbolism of both color and cut for the wedding party, solidified over the nineteenth century and even earlier in the case of many of the accessories, is accepted in the early 2000s with no understanding of origin or is ignored by many modern brides. The idea of wearing a one-time only dress is more prevalent, as most medium-priced gowns have their beaded or pearl decoration glued on rather than sewn. Alternatively the bride simply rents her gown, a tendency common in Japan, but that is making inroads in Europe and the United States.



### Accessories and Their Symbolism

It is often the accessories that historically have provided clothing with bridal significance. Some can be traced to specific time periods while others appear to predate written records. One example of this is the headpiece. Depending on the culture, both men and women may have a specific type of head covering, but it is most unusual for the bride to be bareheaded. The earliest were undoubtedly simple wreaths of plant material: flowers, grain, or leaves, most of which appear to have had fertility symbolism, and possibly served to identify the wedding party. Later, head ornaments of cloth, metal, gems, and even wood began to be used. These were often accompanied by an additional piece of cloth, which might simply cover the hair or be draped over the entire head of the bride, obscuring her features. Certain religions dictate this kind of modesty, historically as well as in the early twenty-first century. However, in European culture, the veil also served as a disguise, a pre-Christian remnant of hiding the bride lest she be attacked by the forces of evil. Identically dressed attendants served not only to assist her, but to also confuse demonic presence.

Bouquets or other objects, such as fans or books, are also important accessories and are symbolic on several different levels. The carrying of flowers or other plants, such as wheat, is not only decorative, but refers to the fertility of the union. Flowers have been accorded symbolism in nearly every culture, but they also express wealth and taste in their choice and cost. In the early 2000s it is most common for Western brides to carry expensive flowers, with only very religious or economically prudent women opting for a prayer book. However, in earlier times, the owning and display of such a luxury item as a book would have lent the bride additional status, and frequently formed one of her betrothal gifts. The wedding ring, a token of affection, an exchange of property in the form of precious metal, and a none-too-subtle warning of future unavailability, is not a universal accessory. This is even more true of the engagement ring, a staple in North America, but not as common in other cultures, even in the West. Additionally, the finger or hand on which the rings are worn vary from culture to culture, as well as historically. Sixteenth-century examples of wedding portraits show the bride wearing a ring on her thumb.

Color symbolism did not play a role in weddings until relatively recently in the West, although now it signifies virginity, and, as mentioned above, the primacy of the white wedding dress flies directly in the face of many other cultures' norms. White is the color of mourning in most Asian cultures. Red, the one color still forbidden to most mainstream Western brides, due to its connotations of immorality ("scarlet woman," "red-light district"), is completely appropriate in other cultural settings. In India, it is the color of purity, and is often worn by brides. In much of East Asia, it is the color of celebration and luck, and therefore appropriate for bridal attire. How-

ever, the tendency toward adopting the Western white wedding, established only in the mid-nineteenth century, seems to be continuing throughout the world, sometimes alone, and sometimes in conjunction with local traditions. At the same time, the white wedding in the West is proving to be far less static than previously thought, evolving as fashions and societal norms do.

*See also Ceremonial and Festival Costumes; Religion and Dress.*

### BIBLIOGRAPHY

- Baker, Margaret. *Wedding Customs and Folklore*. Devon, U.K.: David and Charles, 1977. An early work exploring the symbolism of marriage and its dress.
- Baldizzone, Tiziana, and Gianni Baldizzone. *Wedding Ceremonies: Ethnic Symbols, Costume, and Ritual*. Paris: Flammarion, 2002. One of many new studies that look at modern global practice.
- Cunnington, Phillis, and Catherine Lucas. *Costume for Births, Marriages, and Deaths*. New York: A & C Black, 1972. One of the first, and still important studies of Western ceremonial clothing.
- Foster, Helen Bradley, and Donald Clay Johnson. *Wedding Dress: Across Cultures*. Oxford: Berg, 2003. A rather good exploration of modern global wedding practices.
- Kaivola-Bregenhøj, Annikki. *Bondebryllup*. Copenhagen, 1983. Excellent discussion of European peasant weddings.
- Mordecai, Carolyn. *Weddings, Dating and Love: Customs and Cultures Worldwide, including Royalty*. Phoenix, Ariz.: Nittany, 1998. An imperfect but broad compendium of modern practices.
- Newton, Stella Mary. *Fashion in the Age of the Black Prince: A Study of the Years 1340–1365*. Woodbridge, Suffolk: Boydell, 1980. Reprint, Totowa, N.J.: Rowman and Littlefield, 1999. One of the best studies of fourteenth-century dress, including weddings, using difficult to find primary sources.
- Noss, Aagot. *Lad og Krone: frå jente til brur*. Oslo: Universitetsforlaget, 1991. The most careful case study to date of ethnic wedding traditions, focusing on those of Norway, by one of the pioneers of costume history fieldwork.
- Piponnier, Françoise, and Perrine Mane. *Dress in the Middle Ages*. New Haven, Conn., and London: Yale University, 1997. A book that is significant because it presents much compressed information, and its discussion of garments signifying rites of passage is important.
- Tobin, Shelley, Sarah Pepper, and Margaret Willes. *Marriage à la Mode: Three Centuries of Wedding Dress*. London: The National Trust, 2003.

*Michelle Nordtorp-Madson*

**WESTWOOD, VIVIENNE** Born Vivienne Swire in Glossop in Derbyshire in 1941, Vivienne Westwood originally set out to become a teacher. She married Derek Westwood in 1962; her first child was born a year later and she seemed destined to lead a quiet, suburban life. However, in 1965 she met Malcolm McLaren, a publicist and impresario, whose subversive ideas and alternative



**Vivienne Westwood.** Two models flank designer Vivienne Westwood, displaying her designs for the 1996 spring-summer pret-a-porter collection. Westwood's unconventional fashions often reference historical and traditional dress. © B.D.V./CORBIS. REPRODUCED BY PERMISSION.

lifestyle gave Westwood the opportunity and momentum to break free from her former life and embark on a highly successful career of fashion.

Vivienne Westwood's designs are a reaction against traditional British standards of morality—against petty bourgeois notions of etiquette and propriety. Since her early street style-based collaborations with McLaren, Westwood has defied the ideal of polite, anonymous clothes that express the wearer's ascribed social status. She seeks to transcend definitions of class, gender, ethnicity, and sexual orientation and create outfits that are dramatic—that encourage wearers to carry themselves confidently as they masquerade in theatrical assimilations of eighteenth-century aristocratic dress or traditionally tailored suits adorned with fetish bondage buckles. Westwood is a utopian. Through her work and the ideas she expresses in interviews, she strives to construct new personae for future cultures that draw upon idealized visions of the past inspired by portraiture and film.

During the early to mid-1970s, she and McLaren merged tough biker leather jackets with pornographic imagery and traditional tartans to produce the DIY (do-it-yourself) aesthetic that expressed the antiestablishment spirit of punk. Based in London's King's Road, they changed the name of their shop from time to time to enhance the current collection's ideals, from *Let It Rock* (1971) to *Too Fast to Live, Too Young to Die* (1973) to *Sex* (1974) and finally to *Seditionaries* (1976)—a name and anarchic style that coincided with the increased notoriety of the Sex Pistols, a punk rock band that McLaren managed. Punk enabled Westwood to break free from the suburbs she had felt trapped in and experiment with fashion's power to shock and challenge. Her sex shop-style plastic miniskirts worn with ripped fishnet stockings, buckles, and chains, fractured traditional notions of femininity and beauty. Along with her straggly-knit sweaters, Karl Marx portrait print shirts, and bondage trousers, they became emblems of pop cultural revolt.

Westwood's subsequent work with McLaren was just as closely linked to youth culture, music, and clubs. As her King's Road shop settled into its final incarnation as World's End in 1980, she embarked on a series of collections that explored historical construction techniques. One example was *Pirates*, presented at her first catwalk show in 1981. She continued to play with the relationship between body and fabric in the multilayered bulk of the Buffalo collection of 1982–1983 and the *Witches* collection of 1983–1984, which used sweatshirt fabric cut to pull away from the figure. These collections have inspired other designers; for example, punk was revisited in the early 1990s by Jean-Paul Gaultier and Karl Lagerfeld. Westwood's asymmetrical sportswear-based designs, highlighted with the neon colors that she used in her last collections with McLaren between 1983 and 1984, were seen on catwalks and in such High Street stores as Topshop and H & M in 2002–2003.

Westwood's split from McLaren prompted her shift away from pop culture and street style toward a more thorough exploration of history and tradition. She no longer wanted to be seen as a creator of subcultural dress, but rather as a designer of high fashion posing serious questions about culture, art, and identity. While her standing as one of the most significant British designers of the period was already established in mainland Europe, America, and Japan, she remained an outsider in Britain itself. It was not until the late 1980s that such high fashion magazines as *Vogue* began to feature her work on a regular basis. Before that time, her clothes were seen mainly in style magazines like *The Face* and *i-D*.

Westwood's first post-McLaren collection, *Mini Crini* (1986), indicated the direction she was to take, with its juxtaposition of eighteenth-century corsets, the "crini" (abbreviated 1860s-style crinolines), and huge curved wooden platform shoes that laced up the leg and rocked forward as the wearer walked in them. This collection was fashion created to make an impact; Westwood wanted to distinguish her wearers through references to grandeur, royalty, and the Establishment. In 1987 this dramatic aura was tempered by Westwood's ironic wit and her expertise with rich traditional fabrics: Harris tweed, John Smedley fine knits, and wool baratheia were enlivened with such flourishes as a tweed crown worn with a tiny cape and crini. "You have a much better life if you wear impressive clothes," she remarked at the time (Jones, p. 57).

Westwood's philosophy, a mixture of contempt for late twentieth-century casual dress and reverence for the eighteenth-century Enlightenment's use of classical references, was encapsulated in her collections from 1988 through 1991 under the broad title *Britain Must Go Pagan*. These collections, like the punk fashions before them, sought to challenge existing ideas of status, gender, and display. In this case, however, Westwood strove for refinement and education rather than youthful rebel-

lion. She used togas to add grandeur to traditional suiting, and contrasted light, floating chiffons that evoked both ancient Greece and prerevolutionary France with thick Scottish tweeds and corsets photoprinted with Boucher paintings of rural idylls. The clothing that resulted from these combinations relied heavily upon an idealized vision of the past and required its wearers to take on new personae that suggested their awareness of the fine arts.

Westwood appropriated emblems of aristocratic status and elitism for their power and theatricality. She encouraged people to dress up in princess-style coats like those the Queen wore as a child, or in delicate silk coats with rose-strewn edges like an eighteenth-century gentleman's garment. She has continued to draw on these themes of heritage and culture in her subsequent work. While Westwood is always considered inherently British, and has undoubtedly drawn upon her own country's past, she has been equally transfixed by French art and style. This attraction was summarized in her autumn–winter 1993–1994 collection, *Anglomania*, which harked back to Parisians' fascination with Englishness in the 1780s.

Westwood has consolidated her label since the late 1990s. In 1993 she diversified her collections to appeal to different audiences: the Red Label for ready-to-wear styles, the Gold Label for made-to-measure garments, and in 1998, and the diffusion line *Anglomania* (a less expensive collection aimed at a younger market), which reinterprets such staples as the pirate shirts from her earlier collections. Along with her perfumes, *Boudoir*, launched in 1998, and *Libertine*, launched in 2000, this diversification has enabled her to widen her market and build upon her previous successes.

See also **Extreme Fashions; Gaultier, Jean-Paul; Lagerfeld, Karl; London Fashion; Perfume; Punk; Vogue.**

#### BIBLIOGRAPHY

- Arnold, Rebecca. "Vivienne Westwood's *Anglomania*." In *The Englishness of English Dress*. Edited by Christopher Breward, Becky Conekin, and Caroline Cox. Oxford: Berg, 2002.
- Evans, Caroline, and Minna Thornton. *Women and Fashion: A New Look*. London: Quartet, 1989.
- Jones, Dylan. "Royal Flush: Vivienne Westwood." *i-D* (August 1987): 57.
- Mulvagh, Jane. *Vivienne Westwood: An Unfashionable Life*. London: HarperCollins, 1998.

Rebecca Arnold

**WIGS** Wigs are artificial heads of hair, either cunningly concealing baldness or glaringly obvious fashion items in their own right. The Jewish *sheitel*, for instance, is worn for religious reasons where a woman's natural hair is shielded from the gaze of all men who are not her husband. The Talmud teaches that the sight of a woman's



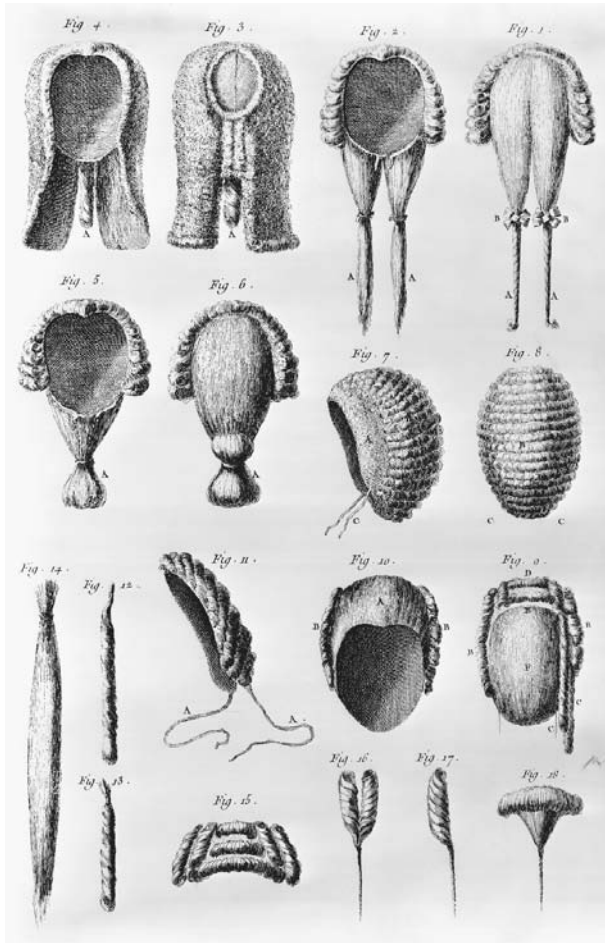

**Illustration of eighteenth-century wigs.** An engraving from the book *The Wigmaker III* shows the different styles of wigs popular during the eighteenth century. White wigs were most popular and were maintained with plaster of paris and starch.  
© BETTMANN/CORBIS. REPRODUCED BY PERMISSION.

hair constitutes an arousal or sexual lure; thus a woman hiding her hair helps protect the fabric of Jewish society. The entertainer Elton John's obvious ginger weave is, of course, completely different, worn to retain an air of youth and as a disguise for baldness.

### Early Wigs

The earliest Egyptian wigs (c. 2700 B.C.E.) were constructed of human hair, but cheaper substitutes such as palm leaf fibers and wool were more widely used. They denoted rank, social status, and religious piety and were used as protection against the sun while keeping the head free from vermin. Up until the 1500s, hair tended to be dressed as a foundation for headdresses, but by the end of the century hairstyles became higher and more elaborate constructions in which quantities of false hair were used to supplement the wearer's own. Hair was gummed and powdered, false curls and ringlets were in fashion,

and, in some cases, a complete head of false hair called a *perruque*, was worn. The French *perruque* was colloquially known as a peruke, periwyk, periwig, and eventually the diminutive *wig* by 1675.

### Seventeenth and Eighteenth Centuries

The seventeenth century saw the complete resurgence of the wig and it became the height of fashion for both men and women, with many shaving their heads beneath for both comfort and fit. Hair historian Richard Corson sees the ascendance of Louis XIV to the French throne as pivotal. The king supplemented his thinning hair with false pieces until "eventually he agreed to have his head shaved, which was done daily thereafter, and to wear a wig." (Corson, p. 215) By the eighteenth century, those who had the finances had a large wig for formal occasions and a smaller one for use in the home. The larger or more "full bottomed" the wig, the more expensive, thus they were also a mark of class and income and the target of wig snatchers. If one was unable to afford a wig, one made one's natural hair look as wiglike as possible. By the mid-eighteenth century, white was the favored color for wigs, and they were first greased then powdered with flour or a mixture of starch and plaster of paris in the house's wig closet using special bellows. Lucrative trades were constructed around their care and maintenance, such as hairdressing, so-called because hair was dressed rather than cut. Women's wigs were particularly high, powdered, and bejeweled, and the subject of much caricature. To achieve the look, hair was harvested from the heads of the rural working classes. Richard Corson noted that the full wig was disappearing by about 1790, however, "when there was a good deal of natural hair in evidence" (Corson, p. 298).

### Nineteenth and Early Twentieth Centuries

After this brief period of respite during the French Revolution, when a natural look and thus natural hair was fashionable, the elaborately dressed hairstyles of the Victorian and Edwardian era demanded a myriad of false pieces or fronts and transformations. As the feminine ideal in the Edwardian era required enormous hairstyles, the natural bulk of the hair was padded out. Lady Violet Harvey recalled,

Enormous hats often poised on a pyramid of hair, which if not possessed, was supplied, pads under the hair to puff it out were universal and made heads unnaturally big. This entailed innumerable hairpins. My sister and I were amazed to see how much false hair and pads were shed at 'brushing time.' (Hardy, p. 79)

The building of massive hairstyles was dependent on the use of *postiche*, the French word for "added hair" and styles included fringes, fronts, switches, pompadour rolls, and frizettes. All hairdressers had a workroom in which postiches were made for sale wherein the posticheur prepared hair. Hair combings were saved and then drawn through a hackle (a flat board with metal teeth sticking

upward) to straighten them. Hair was sorted into bundles ready to be curled into false pieces or curled by a device called a *bigoudis* made of wood or hardened clay. Sections of hair were rolled up on the *bigoudis* and then dropped into water mixed with soda. After being boiled for several hours the dry hair was then unwound and stored—a method that dates back to the Egyptians. If too little hair was obtained from combings it came from other women. It was a commodity to be exploited and one famous source was the Hair Market at Morlans in the Pyrenees, one of a number of hiring fairs where dealers literally bought the hair from women's heads. Much hair was also imported from Asia Minor, India, China, and Japan and boiled in nitric acid to remove the color and vermin. Men wore wigs, too, but this was to hide baldness.

### 1920s to Present

With the introduction of the new bobbed hairstyle in the 1920s, wigs fell out of favor and were worn by older women who were not interested in the newly shorn look. Their use returned in the 1950s, but only as a way of having temporary fantasy hairstyles. The most renowned wigmakers and hairdressers in Europe were Maria and Rosy Carita. In black hairdressing, though, the wig was of supreme importance allowing for fashionable styles without undergoing the time-consuming, and in some instances painful, process of straightening. Black stars such as Diana Ross were known for their stylish wig collections in the mid-1960s. It was not really until the late 1960s that wigs underwent a massive renaissance in white hairdressing practices. Rapidly changing fashion, a space-age chic and the vogue for drip-dry clothes in new man-made fabrics led to a vogue for the artificial over the natural. By 1968 there was a wig boom and it is estimated that one-third of all European women wore what hairdressers called a “wig of convenience.” Men still tended to wear wigs differently moving further toward the naturalism that many women were rejecting. Until the early 1950s, all wigs were made by hand. However, the invention of the machine-made, washable, nylon and acrylic wig in Hong Kong led to cheap, mass-produced wigs flooding the market. The novelty fashion wig or hairpiece became one of Hong Kong's fastest growing exports and by 1970 the industry employed 24,000 workers. In 1963 British imports of wigs and hairpieces from Hong Kong was worth £200,000 (\$350,000); by 1968 it was almost £5 million (\$8.78 million). By 1969 around forty percent of wigs were synthetic and the leading companies in wig development were the American firm Dynel and the Japanese Kanekalon, who both used modacrylics to create wigs that were easy to care for and held curl well. In the late twentieth century, many false forms of hair are used and the change from a long to a short hairstyle can be completed at a whim with extensions that have moved from black hairdressing to white hairdressing. Singers such as Beyoncé and Britney Spears use weaves of all styles and colors openly.

See also **Acrylic and Modacrylic Fibers; Caricature and Fashion; Hair Accessories; Hairdressers; Hairstyles; Head-dress.**

### BIBLIOGRAPHY

- Corson, Richard. *Fashions in Hair: The First Five Thousand Years*. London: Peter Owen, 1965.
- Cox, Caroline. *Good Hair Days: A History of British Hairstyling*. London: Quartet, 1999.
- Hardy, Lady Violet. *As It Was*. London: Christopher Johnson, 1958.

Caroline Cox

**WILDE, OSCAR** Oscar Wilde (1854–1900) was one of the most prominent and influential figures of the fin de siècle. Playwright, author, journalist, dandy-aesthete, wit, and homosexual social critic, his life and work foreshadowed many of the features of twentieth-century popular and creative subcultures, not least their obsession with the cult of celebrity and the act of self-fashioning. Wilde's constant concern with surface appearance and its power also ensured that his distinctive and constantly changing personal image became a style-template for those who wish to dress in extravagant and innovative ways, from actors and artists to pop stars and clubbers.

Born in Dublin in 1854, Wilde was the second son of a leading surgeon, Dr. William Wilde, and Jane Francesca Speranza Elgee, an Irish nationalist poet and translator. Following the traditional route for a boy of his social background and aptitude, Wilde studied classics at Trinity College, Dublin before winning a scholarship to Magdalen College, Oxford in 1874. In photographs of this period Wilde appeared quite the student “masher” in loudly checked suits and bowler hats. There was little to indicate his later espousal of artistic fashions, though his hair was a little longer than the norm for the 1870s. During his time at Oxford Wilde immersed himself in the ideas of Walter Pater and John Ruskin, honing an acute appreciation of ancient and renaissance art on study visits to Greece and Italy. He graduated with a first class degree in 1878. Having established a reputation as a promising poet with the award of the Newdigate Prize for his poem “Ravenna” in the same year, Wilde launched himself on the London social and literary circuit, where he skillfully adapted the learned theories of Ruskin and Pater for a less erudite audience. His talent for self-publicizing soon earned him notoriety as the “Professor of Aesthetics” in such satirical publications as *Punch*, where his flowing hair, loosely tied collars, floral accessories, and velvet suits formed an obvious target for the caricaturists.

By 1881, Wilde's reputation was such that he found his opinions and appearance lampooned in the Gilbert and Sullivan operetta *Patience*, whose libretto ridiculed the current metropolitan taste for “aesthetic” clothing, interior design, and amateur philosophizing. Wilde turned this critique to his advantage by spearheading a promotional



**Oscar Wilde.** Wilde was recognized during his time for his literary works as well as for his outrageous fashion sense. PUBLIC DOMAIN.

lecture tour for the operetta in the United States and Canada during the following year. Dressed in extreme aesthetic garb—which now included breeches, stockings and pumps, fur-trimmed overcoats, cloaks, and wide-brimmed hats—he delivered talks to American audiences on such subjects as “The House Beautiful.” Wilde had his image from this period immortalized in a series of striking portraits by the society photographer Napoleon Sarony that idealized him as a romantic bohemian.

Back in London, Wilde married Constance Lloyd in 1884, setting up an elegant home with her in Chelsea where they raised two sons, Cyril (born 1885) and Vyvyan (born 1886). For the remainder of the 1880s, Wilde had a successful career as a reviewer and editor of the progressive magazine *Woman’s World*, while honing his talents as an essayist and writer of exquisite short stories. During this time, he exchanged the long locks and soft velvets of the *Patience* era for dramatic “Neronian” curls—a subversive reference to the pagan moral code of imperial Rome—and urbane Savile Row tailoring, the better to represent himself as the epitome of cosmopolitan stylishness.

By the late 1880s Wilde was beginning to explore the then dangerous territory of male to male desire, both

in his personal life and as a subject for artistic expression. He experienced his first homosexual relationship with a Cambridge undergraduate named Robert Ross in 1886, which partly inspired him to write an essay on Shakespeare’s sonnets, “The Portrait of Mr. W. H.,” exploring the thesis that Shakespeare’s creativity was derived from his love for a boy actor. Wilde published the first version of his most explicit investigation of the demi-monde in which he was now operating in 1890. *The Picture of Dorian Gray* was not only heavily informed by French decadent literature in terms of style and subject matter, but also contained expressions of the amoral outlook that would bring Wilde into contact in 1891 with his most infamous lover, Lord Alfred Douglas. In tandem with this search for hedonistic sensation, which was the ultimate outcome of the “art for art’s sake” philosophy of aestheticism, Wilde was also a supporter of the socialism espoused by William Morris. He wrote his influential essay “The Soul of Man under Socialism” during the same period. In fashion terms, the ideals of socialism found a corollary in the rational Liberty style of “anti-fashion” dressing adopted by Constance Wilde and promoted by Oscar in his journalistic output.

Wilde’s popularity as an author of astringent drawing-room comedies for the London stage peaked during the first half of the 1890s. Following the success of *Lady Windermere’s Fan* in 1892, he went on to produce *A Woman of No Importance*, *An Ideal Husband*, and *The Importance of Being Earnest*. Besides opening the mores and hypocrisies of contemporary fashionable life to devastating scrutiny, these plays also afforded an opportunity for sophisticated costume designs that influenced the modes of the day. While the drawing-room plays enjoyed the critical acclaim of polite society, Wilde was also developing further his interest in decadent and erotic themes. These were represented most forcefully in Wilde’s association with the avant-garde journal *The Yellow Book* and in his play *Salome*, which was refused a license for production in London on the grounds of obscenity.

The tension between Wilde’s public and private interests snapped in 1895, when he rashly brought charges of criminal libel against the Marquess of Queensbury, who was enraged by Wilde’s liaison with his son, Lord Alfred Douglas. The marquess had been accusing Wilde of “unnatural acts” to all who would listen. On the collapse of the libel trial Wilde was himself arrested for “acts of gross indecency with other male persons,” for which he was eventually found guilty and sentenced to two years’ imprisonment with hard labor. In 1897, during his incarceration, Wilde authored *De Profundis*, a confessional account of his fall. He published “The Ballad of Reading Gaol,” a poem that captured the suffering of prison life, after his release and exile to Paris in 1898. Though the image of Wilde in convict’s clothing provided a fitting costume for the final act of a drama that he himself might have written, he never fully recovered from the shame and physical discomfort caused by his



punishment, and died a broken man in Paris in 1900. His remains were transferred to the Cimetière du Père-Lachaise in 1909, where they were marked by Jacob Epstein's powerful sculptured angel.

Following decades when his name, works and image were associated in the puritanical Anglo-Saxon world with "unmentionable vices," Wilde's reputation as a gifted writer was gradually restored from the 1950s onwards. Sympathetic film treatments of his life and plays helped bring his sparkling legacy to a new generation, and the counterculture of the 1960s interpreted Wilde as a sexual and aesthetic revolutionary. By the 1980s and 1990s Wilde's complex personality and self-contradictory proclamations made him once again the focus of intense study and speculation. For the fashion theorist and historian, Wilde's life and work undoubtedly offer a rich seam of material for further research.

*See also* **Aesthetic Dress; Dandyism; Fashion and Homosexuality; Fashion and Identity; Gender, Dress, and Fashion; Savile Row; Theatrical Costume.**

#### BIBLIOGRAPHY

- Cohen, Ed. *Talk on the Wilde Side: Toward A Genealogy of a Discourse on Male Sexualities*. London: Routledge, 1993. An examination of the relevance of Wilde's trial to modern understandings of homosexual identities.
- Ellmann, Richard. *Oscar Wilde*. London: Hamish Hamilton, 1987. The most authoritative and comprehensive biography of Wilde published to date.
- Holland, Merlin. *The Wilde Album*. London: Fourth Estate Limited, 1997. An excellent visual resource for images of Wilde and his milieu.
- Kaplan, Joel, and Sheila Stowell. *Theatre and Fashion: Oscar Wilde to the Suffragettes*. Cambridge, U.K.: Cambridge University Press, 1994. An innovative study of the relationship between the theater and sartorial culture in the 1890s.
- Sinfield, Alan. *The Wilde Century: Effeminacy, Oscar Wilde and the Queer Movement*. London: Cassell, 1994. A sophisticated account of the political and theoretical afterlife of Wilde in the twentieth century.
- Sloan, John. *Oscar Wilde*. Oxford, U.K.: Oxford University Press, 2003. A useful summary of the social and literary contexts of Wilde's life and work.

*Christopher Breward*

**WINDBREAKER** The windbreaker, or anorak, otherwise known as a windcheater in Great Britain, is a short, close-fitting garment with a hood, designed for the upper part of the body to give protection from the wind. The windbreaker, worn by men and women alike, is to casual dressing what the overcoat is to formal dress.

#### History

The windbreaker first became popular as an item of informal outerwear in the 1970s, but its history can be traced back almost 500 years. It is similar to, and de-

scended from, the parkas worn by Inuits in arctic conditions. In fact, the word "anorak" is derived from the Danish interpretation of the Inuit word *annoraaq*.

In one version, the Inuit parka was made of two animal skins (either seal or caribou) sandwiched together, with the skin side of each facing outward and the hair side facing inward to trap warm air and retain it for insulation purposes. Although it was not a rain garment as such, it was generally waterproofed, using seal gut until other methods were introduced during the nineteenth century. These parkas were adapted by Western polar explorers in the late nineteenth and early twentieth centuries, and modified versions entered the twentieth-century sports wardrobe. Parkas became standard wear for skiing and other winter sports, and gradually were adopted for ordinary outdoor use in the winter. After World War II, nylon and other artificial-fiber textiles replaced animal skins in the production of parkas, and advances in the development of waterproof fabrics and efficient insulating materials led to the production of parkas that were thinner and less bulky than older versions. During the 1970s, anoraks and other forms of casual jackets grew in popularity among younger men searching for outerwear that was both functional and fashionable.

Modern windbreakers are usually made from nylon, poly-cotton, or nylon/cotton mixes. These fabrics may be rubberized, oiled, or treated with other waterproofing finishes; at the more expensive end of the market, the garments are designed with stormproof taping on all seams to make them impenetrable to the rain. The modern version is also cut slightly longer to cover the buttocks; cuffs are elasticized and pockets are often slanted for ease of entry, and are at hip level. The hood should fold down, close with a drawstring, and either fit into the collar or be detachable.

The windbreaker has had a significant impact on men's fashions. The rise of sportswear during the 1970s coincided with a boom in spectator sports, such as both soccer (known as football in Europe) and American football. Fans who filled stadiums in cold weather wanted good-looking protection from the elements, and numerous designers offered versions of the windbreaker to fill that demand. In the early twenty-first century, nearly every sportswear and casual-wear company has a version of a windbreaker in its collection. Most are produced to keep the wearer warm during sporting activities such as golf, boating, football, or tennis. More significantly, the windbreaker has taken the place of raincoats and overcoats in most younger men's wardrobes.

*See also* **Outerwear; Parka.**

#### BIBLIOGRAPHY

- Amies, Hardy. *A, B, C of Men's Fashion*. London: Cahill and Co. Ltd., 1964.
- Byrde, Penelope. *The Male Image: Men's Fashion in England 1300–1970*. London: B. T. Batsford, Ltd., 1979.

- Chenoune, Farid. *A History of Men's Fashion*. Paris: Flammarion, 1993.
- De Marley, Diana. *Fashion For Men: An Illustrated History*. London: B. T. Batsford, Ltd., 1985.
- Keers, Paul. *A Gentleman's Wardrobe*. London: Weidenfeld and Nicolson, 1987.
- Roetzel, Bernhard. *Gentleman: A Timeless Fashion*. Cologne, Germany: Konemann, 1999.
- Schoeffler, O. E., and William Gale. *Esquire's Encyclopedia of 20th Century Men's Fashions*. New York: McGraw-Hill, 1973.
- Williams-Mitchell, Christobel. *Dressed for the Job: The Story of Occupational Costume*. Poole, England: Blandford Press, 1982.

Tom Greatrex

**WINDOW DISPLAYS** The eighteenth and early nineteenth centuries saw an evolution in shopping spurred by a faster turnover of manufactured “fashionable” goods and an increase in department stores selling them. These shops pioneered new techniques of window display. Rather than piling their stock up—as had been common in markets and bazaars—they sold goods in mannered and self-conscious window displays, intended to sell nonessential goods.

In cities, where competition was strongest, stores had larger windows and more frequently changing displays. A visitor to London in 1786 wrote of “A cunning device for showing women’s materials whether they are silks, chintzes, or muslins, they hang down in folds behind the fine high windows so that the effect of this and that material, as it would be in the ordinary folds of a woman’s dress, can be studied” (Adburgham, p. 6). This comment suggests that there was an awareness of sophisticated marketing techniques and a developing vocabulary for display in the late eighteenth century, which would be developed but not improved upon by later generations.

By the nineteenth century the small store with glass windows and some form of gas lighting dominated the main street. The arrival of department stores in the 1850s—multistoried buildings that utilized plate glass in long, uninterrupted window displays—would herald a new display aesthetic. Fashion goods began to be displayed in lifelike room settings, with mannequins. Known as “open displays,” these windows relied on themes and narratives, rather than sheer quantity of goods, for visual impact. The window display was now contextualizing goods, giving them precise domestic or cultural settings and imparting qualities other than practicality and price. In these displays the fixtures, stands, and mannequins, came into their own. Unfashionable stock goods continued to be displayed as though they were on a market stall—piled high or stacked in rows in the windows in “massed displays.”

### Professionalization of Display Trade

These open displays were developed first in America, where the professionalization of the display trade had begun in the late nineteenth century. The display technocrat L. Frank Baum (who would later write *The Wizard of Oz*) began the first journal aimed at the display trade—*The Show Window* in 1897—and founded the National Association of Window Trimmers in 1898, which did much to raise the status of window trimmer to that of display manager. America had a large number of colleges teaching commercial design based upon the work of pioneering consumer psychologist Walter Dill-Scott, author of *Psychology of Advertising* in 1908. His theories for appealing to hidden desires of customers using particular colors, images, and formations in advertising layouts were applied to window display through numerous handbooks and journals detailing the creation of the “selling shop window.”

This approach was brought over to England by Gordon Selfridge (a friend of L. Frank Baum) and his display manager, Ernst Goldsman. Both men had worked at Marshall Fields department store in Chicago in the 1890s, where Selfridge had introduced radical and innovative methods of display and marketing, starting the first window displays and display department. Selfridge’s department store in London opened in 1909 with the longest window facade ever seen in Britain. The store achieved instant fame for its window displays: “They gaped in amazement at the American-style window-dressing with its life-like scenes and with wax models arranged in realistic poses” (Honeycombe p. 205). Goldsman was integral to the professionalization of the British display trade, founding the National Association of British Display Men in 1919. Such display organizations disseminated new ideas via lectures, display fairs, and their journals.

### Art and Display

In Germany the design reform theories taught at the Deutsche Werkbund and later the Reimann School, in the first decades of the twentieth century, led to a new style of Modernist window display. The objects and fixtures were reduced to a bare minimum and arranged on strong geometric lines. These Modernist display ideals were disseminated when many window display managers left Germany for political reasons in the first decades of the twentieth century. The émigré designer Frederick Kiesler, for instance, was a Romanian architect, designer, and member of the De Stijl group who went to America in 1926. By 1928 he was working designing Modernist window displays at Saks and authoring the influential book *Contemporary Art Applied to the Store and Its Display* in 1929.

The photographer Eugène Atget had been documenting Parisian shop windows since the 1890s, and these images had been influential for succeeding generations of artists, particularly the Surrealists. Mass cultures, in-



**Window shopping in Kuwait.** First seen in eighteenth century Europe, window displays appeal to passersby in shopping malls worldwide. © ED KASHI/CORBIS. REPRODUCED BY PERMISSION.

cluding window display, had become subject matter for artists such as Léger, Max Ernst, and Salvador Dali. Both Kiesler and Dali used the window itself as a frame in their commercial display work and in England commercial designers like Misha Black, Edward McKnight Kauffer, and Tom Eckersley also worked in display.

### Hollywood

The extreme modernist displays would, for the most part, be confined to small designer boutiques. The rest of the retail industry was looking toward America and the film industry for inspiration. There was an obvious corollary between the brightly lit shop window display and the cinema screen and the new and “showy” style of window display developed in America. In the 1930s these displays drew on contained visual references from films and advertising to create windows that looked like stills from films: brightly lit, full of oversized props, shiny fixtures, and film-star-like mannequins. Film and magazine promotional “tie-in” displays became popular. Sometimes the shops were selling fashions copied from the film, but often these displays would only loosely link the goods in the window with the film, hoping that the merchandise would sell if it were associated with the glamour of Hol-

lywood. Advertising display agencies, which (on both sides of the Atlantic) mass-produced display campaigns for branded goods, were particularly well placed to take advantage of the mass appeal of film tie-ins.

World War II halted the progress of window display in Europe. As stores reopened for business after the war their windows were old fashioned and empty of goods. American display remained strong but uninspired. It was not until the 1960s, when display again became subject matter for artists such as Claes Oldenburg, Roy Lichtenstein, and Andy Warhol—particularly the bright spaces of food supermarkets—that creativity was revived. Warhol, who had begun his career in display, would combine the two when he introduced his pop paintings into windows commissioned by Bonwit Teller. American department stores would carry the creative banner of window display through much of the late twentieth century, working with artists such as Jasper Johns and Robert Rauschenberg.

Although some large stores continue to have display departments, shop windows across the world have been given over to the homogenous visual merchandising campaigns of the big brand names, often containing only tailor’s dummies and photographic backdrops. It is the



designer boutique that is pioneering truly creative work in the beginning of the twenty-first century. Shops such as Prada and Comme des Garçons prove that the window display can still offer enough beauty, theatre, and spectacle to halt a passerby.

See also **Department Store; Mannequins; Shopping.**

#### BIBLIOGRAPHY

- Adburgham, Alison. *Shops and Shopping, 1800–1914*. London: Allen and Unwin, 1964.
- Honeycombe, Gordon Selfridge. *Seventy-five Years: The Story of the Store, 1909–1984*. London: Gordon Park Lane Press, 1984.
- Kiesler, Frederick. *Contemporary Art Applied to the Store and Its Display*. London: Pitman and Sons, 1930.
- Leach, William. *Land of Desire*. New York: Pantheon Books, 1993.
- Marcus, Leonard S. *The American Store Window*. New York: Whitney Library of Design, 1978.
- Walsh, Claire. “Shop Design and the Display of Goods in Eighteenth-Century London.” *Journal of Design History* 8, no. 3 (1995): 157–176.
- Ward, Janet. *Weimar Surfaces: Urban Visual Culture in 1920s Germany*. Berkeley: University of California Press, 2001.

Jane Audas

**WINDSOR, DUKE AND DUCHESS OF** If Bettina Zilkha’s International Best Dressed List extended to couples, the Duke and Duchess of Windsor would be its king and queen. As individuals, their influence on twentieth century fashion was considerable, but combined it was unassailable. From the 1930s to the 1960s, the influence they exercised was all the more apparent for the media attention that magnified their sway on the public’s imagination.

#### Biography

The Duke of Windsor was born Prince Edward of York on 23 June 1894. With the death of his grandfather, King Edward VII in 1910, his father was crowned King George V. Upon his father’s accession, Prince Edward of York became Duke Edward of Cornwall, and on his sixteenth birthday, Prince Edward of Wales.

Bessie Wallis Warfield, who was to become the Duchess of Windsor, was born in Pennsylvania on 19 June 1896. Her upbringing, by her own admission, was modest and unexceptional. When she met Prince Edward of Wales for the first time around 1930, she had been married twice. Her first husband was Earl Winfield Spencer Jr., and her second was Ernest Aldrich Simpson, an American living in London.

It is generally accepted that the Prince of Wales and Mrs. Simpson began their affair in 1934. Following the

death of King George V, the prince was crowned King Edward VIII on 20 January 1936. That summer, he took Mrs. Simpson on a yachting holiday in the Eastern Mediterranean. Press coverage of the trip created a scandal, complicating the king’s decision to marry Mrs. Simpson. Parliament refused the king’s marriage request on the grounds of Mrs. Simpson’s status as a twice-divorced foreign commoner. A “Constitutional Crisis” ensued, which resulted in the king’s abdication on 11 December 1936. In his abdication speech he explained, “You must believe me when I tell you that I have found it impossible to carry out the heavy burden of responsibility and discharge my duty as King as I would wish to do, without the support of the woman I love” (Ziegler, p. 331).

Upon his abdication, he became His Royal Highness the Duke of Windsor, and with his marriage to Mrs. Simpson on 3 June 1937, she became the Duchess of Windsor. The title Her Royal Highness, however, was never conferred upon her. Apart from spending time in the Bahamas during World War II, the Duke and Duchess of Windsor remained in exile in France for the rest of their lives. The duke died on 18 May 1972, while the duchess, who was last seen in public in 1975, died on 24 April 1986.

#### The Duke: Trend Setter

More than any other individual, the Duke of Windsor was responsible for a transformation of men’s dress in the twentieth century. His personal preference for rejecting the received notions of Victorian and Edwardian “proprieties” not only influenced the men of his generation, but also—as Chanel is credited for having done with women—created a modern paradigm that persists to this day. What Nicholas Lawford said of him in the 1930s remained true of the Duke all his life, “In a world where men tend to look more and more alike, he seems more than ever endowed with the capacity to look like no one else” (Menkes, p. 95).

The Duke of Windsor preferred comfortable clothes that allowed freedom of movement, a style that he described as “dress soft” (The Duke of Windsor, 1960, p. 110). In the 1930s, he was one of the first men to wear unlined, unstructured jackets. From 1919–1959, these were made for him by Frederick Scholte, a Dutch-born, London-based tailor who disapproved of any form of exaggeration in the style of a jacket. As the duke commented in *A Family Album*, his treatise on style written in 1960, “Scholte had rigid standards concerning the perfect balance of proportions between shoulders and waist in the cut of a coat to clothe the masculine torso” (The Duke of Windsor, 1960, p. 99). The sleeves of the duke’s jackets were usually adorned with four buttons, and he preferred welted pockets rather than pocket flaps.

Before World War II, Forster and Son in London tailored the duke’s trousers. “I never had a pair of trousers

made by Scholte,” the duke explained. “I disliked the cut of them; they were made, as English trousers usually are, to be worn with braces high above the waist. So preferring as I did to wear a belt rather than braces with trousers, in the American style, I invariably had them made by another tailor” (*The Duke of Windsor*, 1960, p. 103). For every jacket the duke had made, two pairs of trousers were produced. These he wore in strict rotation. In 1934, along with his brother, the Duke of York, and his cousin, Lord Louis Mountbatten, he replaced the conventional button flies with zip flies. A heavy smoker all his life, the duke instructed Forster and Son to make his trousers with a slightly wider left pocket with no fastening, allowing him easy access to his cigarette case, which he always carried in his left pocket. The duke preferred trousers with cuffs or turn-ups. With the adoption of rationing restrictions in Britain during World War II, which banned turn-ups, he placed all subsequent orders with H. Harris, a tailor based in New York.

The London firm of Peal and Co. made the duke’s shoes, Lock and Co. his hats, and Hawes and Curtis his shirts and ties. He favored shirts with soft, unstarched cuffs and collars and wore his ties, which he ordered with thick inner linings, with a wide “four-in-hand” knot. Despite popular opinion, the Duke of Windsor did not, in fact, wear a style known as the “Windsor knot.” As he explains, “The so-called ‘Windsor knot,’ was I believe regulation wear for G.I.s during the war, when American college boys adopted it too. But in fact I was in no way responsible for this. The knot to which the Americans gave my name was a double knot in a narrow tie—a “Slim Jim” as it is sometimes called” (*The Duke of Windsor*, 1960, p. 116).

As a keen sportsman, the Duke of Windsor paid particular attention to his sporting attire. In the 1920s, he popularized the wearing of plus fours, which became his standard dress for hunting and sporting pursuits. Disliking the traditional style with fastenings below the knees, he developed a loose-fitting version with a soft cotton lining, which he wore slightly lower than the traditional four inches below the knee. When playing golf, he would wear them with brightly colored Argyle socks and Fair Isle sweaters. Commenting on the Prince at play, Lawford noted, “He was quite loud in the way he mixed his checks, but he represented style to his generation” (Menkes, p. 102).

Like his sportswear, the duke’s highland dress expressed his theatrical and audacious use of color, pattern and texture. He wore kilts, often made by Chalmers of Oban or William Anderson and Sons in Scotland, in casual settings, usually at “The Mill,” the Windsor’s weekend retreat just outside Paris. These he would wear with a leather sporran, in which he would store his cigarettes. The duke preferred “tartans which I have the right to wear—Royal Stuart, Hunting Stuart, Rothesay, Lord of the Isles, Balmoral” (*The Duke of Windsor*, 1960,



**The Duchess of Windsor, 1951.** The duchess was known to have bought entire collections from a couture designer. Pictured here, she wears a flowered and beaded strapless Dior ball gown. © CONDÉ NAST ARCHIVE/CORBIS. REPRODUCED BY PERMISSION.

p. 128). In *A Family Album*, the duke describes wearing a suit of Rothesay hunting tartan, originally belonging to his father, that triggered a vogue for tartan in the 1950s,

I happened to wear it one evening for dinner at La Croe near Antibes, where the Duchess and I lived for a while after the last war. One of our guests mentioned the fact to a friend in the men’s fashion trade, who immediately cabled the news to America. Within a few months tartan had become a popular material for every sort of masculine garment, from dinner jackets and cummerbunds to swimming-trunks and beach shorts. Later the craze even extended to luggage (*The Duke of Windsor*, p. 129).

One of the Duke of Windsor's most notable sartorial innovations was the introduction, in the 1920s, of the midnight blue evening suit, an alternative to the traditional black evening suit. Wanting to enhance his well-dressed standing in the popular press as well as soften men's formal wear, he explained,

I was in fact 'produced' as a leader of fashion, with the clothiers as my showmen and the world as my audience. The middle-man in this process was the photographer, employed not only by the Press but by the trade, whose task it was to photograph me on every possible occasion, public or private, with an especial eye for what I happened to be wearing (*The Duke of Windsor*, 1960, p. 114).

The Prince of Wales understood that in black and white photography, unlike black, midnight blue allowed the subtle details of tailoring, such as lapels, buttons, and pockets, to become more apparent.

It is through these photographs that the Duke of Windsor influenced fashionable men of his generation, and, indeed, continues to influence fashionable men today. Through their designs, Ralph Lauren, Paul Smith, Sean John Combes, and a host of other men's wear designers pay homage to the Duke of Windsor's witty and idiosyncratic approach to self-presentation. As Diana Vreeland (1906–1989), editor of *Harper's Bazaar* and *Vogue*, said of him, "Did he have style? The Duke of Windsor had style in every buckle of his kilt, every check of his country suits" (Menkes, p. 126).

### The Duchess: Trend Follower

Unlike the Duke of Windsor's innate sense of style, the Duchess of Windsor's self-presentation, as Suzy Menkes, fashion editor for the *International Herald Tribune*, has observed, was "a product of rigorous effort rather than inherited or natural taste" (p. 95). She was a picture of elegance, preferring simple, tailored clothes with no superfluous details or decoration. She remained on the *International Best Dressed List* for more than forty years, and upon her death in 1986, Elle commented, "She elevated sobriety to an art form" (Menkes, p. 95).

Being immaculate was the hallmark of the Duchess of Windsor's personal style. As Cecil Beaton (1904–1980), a British portrait photographer, commented, "She reminds one of the neatest, newest luggage, and is as compact as a Vuitton travelling-case" (Beaton, p. 27). Beaton's first impression of the Duchess, formed in 1930 before she had acquired her title, was less than favorable. He recalled her as "brawny and raw-boned in her sapphire blue velvet" (Tapert and Edkins, p. 92). Four years later, however, when they met again, the Duchess had changed. Beaton commented, "I liked her immensely. I found her bright and witty, improved in looks and chic" (Tapert and Edkins, p. 92). Lady Mendl (Elsie de Wolfe), who remained the Duchess of Windsor's friend and mentor throughout her life, was largely responsible for Mrs. Simpson's transformation. It was Lady Mendl who in-

troducted her to Mainbocher, who was to dress her until he retired in 1971. As Vreeland commented, "Mainbocher was responsible for the Duchess's wonderful simplicity and dash" (Menkes, p. 98).

Mainbocher was to make the Duchess of Windsor's wedding ensemble and trousseau. The wedding ensemble included a simple, floor-length dress and matching long-sleeved jacket in "Wallis Blue" silk crepe. The color was specially developed by Mainbocher to equal that of the Duchess of Windsor's eyes. The dress complemented the duchess's style of fashion austerity, being modest but not prudish. Shortly after her marriage, copies of the dress were sold at retailers for a small fraction of the original's cost, from \$25 at Benwit Teller to a mere \$8.90 at Klein's cash-and-carry. Within a few months, the "Wally" dress made its way to the United States, where it was available from department stores in a variety of styles, colors, and materials.

Cecil Beaton became the Duchess of Windsor's unofficial photographer. In this position, he was able to play an important role in the construction and depiction of her public image. Beaton, in fact, took photographs of the royal wedding the day before the actual ceremony. Several weeks before the marriage, he also took a series of famous photographs of the Duchess of Windsor wearing models from Elsa Schiaparelli's Spring/Summer 1937 collection, including the legendary "Lobster Dress" with a print designed by Salvador Dalí. Like Mainbocher's designs, Schiaparelli's clothes appealed to the Duchess of Windsor's rigorous, restrained aesthetic. She liked Schiaparelli's evening suits, in particular, and made them her trademark. Indeed, the duchess was at her most elegant in smart, impeccably tailored suits, a look that Cecil Beaton referred to as her "trim messenger-boy's suits" (Menkes, p. 102).

While the Duchess of Windsor's daywear tended to be plain and simple, her evening wear revealed a more feminine, romantic sensibility. As Danielle Porthault of Yves Saint Laurent commented, "Her Royal Highness's style was sobriety by day and fantasy and originality at night" (Menkes, p. 116). During the 1930s, the Duchess of Windsor favored Mainbocher, Schiaparelli, and Vionnet, while after World War II she preferred Dior, Givenchy, and Yves Saint Laurent. These she would wear with shoes by Roger Vivier, who began working for the House of Dior in 1953. According to Vreeland, one of the Duchess of Windsor's many sartorial innovations was the short evening dress.

The Duchess of Windsor's recipe of "sobriety by day and fantasy at night" included ingredients of wit and irony, often expressed in her exuberant use of jewelry. Her two favorite jewelers, Cartier and Van Cleef and Arpels, competed with each other to provide the Duchess with ever more lavish and innovative creations. The Duchess of Windsor's simple day suits proved the perfect backdrop for her flamboyant broaches, bracelets, ear-



rings and necklaces, as did her more romantic confections worn at night. One of her more memorable pieces of jewelry was a bracelet made from jeweled crosses, which she wore at her wedding. Each cross represented “a stepping stone in their love story, and a cross they had to bear” (Menkes, p. 151).

The Duchess of Windsor once told her friend and confidante Elsa Maxwell, “My husband gave up everything for me ... I'm not a beautiful woman. I'm nothing to look at, so the only thing I can do is dress better than anyone else” (Tapert and Edkins, p. 97). But she did much more than this. Not only did she dress to enhance the idiosyncrasies of her physicality, enhanced by her coiffure by Alexandre, but she dressed with a consciousness of how her image would be received by both the press and public. As Vreeland observed, “She had a position and dressed to it” (Menkes, p. 138). In this respect, she had a lasting influence on royal women and stateswomen alike, perhaps most notably Jacqueline Kennedy and Diana, Princess of Wales.

See also **Diana, Princess of Wales; Fashion Icons; Fashion Magazines; Formal Wear, Men's; Mainbocher; Neckties and Neckwear; Royal and Aristocratic Dress; Schiaparelli, Elsa; Tartan.**

#### BIBLIOGRAPHY

- Beaton, Cecil. *Cecil Beaton's Scrapbook*. New York: Charles Scribner's Sons, 1937.
- Duchess of Windsor. *The Heart Has Its Reasons*. New York: D. McKay Company, 1956.
- Duke of Windsor. *A King's Story*. New York: Putnam, 1951.
- . *A Family Album*. London: Cassell, 1960.
- Menkes, Suzy. 1988. *The Windsor Style*. Topsfield, Mass.: Salem House Publishers, 1988.
- Sothebys. *The Duke and Duchess of Windsor*. New York: Sothebys, 1997.
- Tapert, Annette, and Diana Edkins. *The Power of Style: The Women Who Defined the Art of Living Well*. New York: Crown, 1994.
- Ziegler, Philip. *King Edward VIII*. London: Collins, 1990.

Andrew Bolton

**WOMEN'S WEAR DAILY** Its own motto is “the retailer's daily newspaper,” but within the fashion industry, *Women's Wear Daily* is widely referred to as “the bible of the business.” It is far more than just a trade publication serving an industry. With its unique mix of hard business, financial stories, society gossip, and biting fashion reviews, *WWD* (as it is commonly known) is a high-impact cultural voice.

*Women's Wear* first appeared as a supplement to the 21 May 1910 edition of the *Daily Trade Record*, a broadsheet that tracked the burgeoning, if rather dry, textiles imports and apparel manufacturing businesses. Both were

products of Fairchild Publications, started by Edmund Wade (E.W.) Fairchild and his brother Louis E. Fairchild. But with department stores booming and women's fashion becoming a business unto itself, it seemed obvious to the Fairchilds that the *Women's Wear* supplement could succeed as a stand-alone publication. “There is probably no other line of human endeavor in which there is so much change as in the product that womankind wears,” opined an editorial in one of the first editions. *Women's Wear* became a daily on 15 July 1910, publishing every day but Sunday and selling for 15 cents.

The next year, E. W. Fairchild opened a Paris bureau, since that city's houses basically dictated the course of fashion; correspondents would wire stories about the trends in French fashion, such as the “universally repudiated hobble skirt,” or Paul Poiret's scandalous Turkish trousers of 1913. In 1912, one of the paper's Paris correspondents, Edith L. Rosenbaum, happened to be on the maiden voyage of the Titanic; she survived and gave *Women's Wear* a version of the tragedy that noted which prominent retailers were on the ship (Isidore Straus, a founder of Abraham & Straus, perished with his wife) and what some of the survivors wore in the lifeboats (“Lady Duff-Gordon made her escape in a very charming lavender bathrobe”).

The paper by then was based at 822 Broadway and had three Linotype machines dedicated to rolling out its copies. In 1927, Fairchild added the “Daily” to its name. Although the paper acknowledged world events, high society, Hollywood movies, and the like, its content was always within the context of the fashion industry. Coverage was always focused on business, not personalities. *WWD* adopted the mind-set of its readers slavishly following Paris designers like Christian Dior, Cristóbal Balenciaga, and Coco Chanel while essentially ignoring homegrown talents. It was first and foremost a trade paper, with a fairly narrow, albeit loyal and influential readership.

The second generation took over in 1948 when Louis E. Fairchild passed the president's title to his nephew, Louis W. But it wasn't until the charismatic, confident, worldly Princeton-educated John B. Fairchild (son of Louis W.) arrived in 1960, after a stint in the Paris office, that *WWD* shook off its old identity as a niche-market trade paper and became a cultural chronicler crackling with opinion. “It was as if a tornado hit 7 East 12th Street,” recalled fashion journalist Etta Froio, then just starting her *WWD* career as a market editor. “In just a few weeks, he swept away every trace of the musty, stodgy newspaper we had known and set out to create a new era of style and status.”

During his time in Paris, Fairchild had decided that the most interesting thing about fashion wasn't the clothes as much as the people who made and wore them. He began establishing the new tone of *WWD* there, as he befriended Coco Chanel, Christian Dior, Yves Saint Laurent, Pierre Bergé, and Pierre Cardin, among others.

Once back in New York, he expanded that vision to include the entire industry. Before John B., *WWD* had more or less ignored society, except as it pertained to the fashion business. Now, the paper began running on-the-street pictures of chic socialites and interviews with sexy young starlets like Julie Christie, Brigitte Bardot, Vanessa Redgrave, Jane Fonda, and Faye Dunaway. Even counterculture artists, rock stars, and scandalous trends (Andy Warhol, Patti Smith, braless women, the invasion of blue jeans), barely acknowledged in the mainstream press, were investigated and reported on.

Fairchild and *WWD* were instrumental in shifting the world's attention to the merits of American designers, giving their clothes and their personal style more attention than either had ever received. He covered designers such as Halston, Perry Ellis, Oscar de la Renta, and Calvin Klein as much for their social lives as for their collections. "We became fascinated with the personalities of the business executives and the social world," said John B. Fairchild in an interview he gave for *WWD*'s 90th Anniversary edition in 2001. "We were looking for people who made the world tick. That's what it has to be about. All the other coverage then was just endless descriptions of clothes. Nothing to me is more boring than that!" This new approach to fashion was seen in the paper's spin-off magazine *W*, founded in 1972, which combines edgy coverage of fashion with features such as celebrity interviews and news of society events.

When it came to modern women, Fairchild was particularly obsessed with Jacqueline Kennedy Onassis, sending photographers to wait outside restaurants like La Grenouille and Le Cote Basque where she regularly lunched. He also tracked chic young socialites like Babe Paley, Slim Keith, and CZ Guest. He had his editors write stinging reviews of collections that sometimes infuriated the designers (and occasionally resulted in banishment, which never lasted more than a season) but always delighted the readers. The phrases *WWD* invented to describe this gilded group have entered the common lexicon: the BPs (beautiful people), Nouvelle Society, Social Cyclones, Walkers (the men who escort Social Cyclones to events), and HotPants, coined in 1970 to describe indecently short shorts. The paper's power grew to the point that its decrees could make a trend or a designer; *Time* magazine put Fairchild on the cover of its 14 September 1970 issue, labeling him "The Man Behind Midi Mania."

*WWD* courted controversy, frequently needling designers—its review of Saint Laurent's first collection for Dior said the dresses looked like toothpaste tubes on top of a brioche—and occasionally banishing them from the pages. The most famous example was an estrangement lasting for several years between the paper and Geoffrey Beene. Under John B. Fairchild's editorship, *WWD* added theater, restaurant and movie reviews, lengthy interviews with celebrities such as Truman Capote, Barbra

Streisand, Alfred Hitchcock, and Cassius Clay (pre-Muhammad Ali), and even coverage of the social doings of the White House. The paper's Washington coverage prompted Henry Kissinger to complain that it was giving his active social life too much attention. *WWD* became a must-read not just for retail and business executives, but also for socialites, public-relations people, talent agents, and even politicians.

A new round of conspicuous consumption in the 1980s fit perfectly with the paper's exuberant coverage of the worlds of fashion and society. *WWD* gave the Reagan White House ample play. Couture came back, exemplified by Christian Lacroix's bubble dress and the swept-up hairdo, and a new generation of celebrities designed and wore the high-end fashions of the decade. Designer Carolynne Roehm, for example, was married to the wealthy Henry Kravitz, and appeared in the pages of *WWD* both as a designer and a socialite. The recession of the late 1990s that accompanied the bursting of the dot-com bubble was like a morning-after hangover after the long party of the 1980s and early 1990s. The pages of *WWD* began to fill with news of liquidations and reorganizations in the fashion industry, and the flight of manufacturing to Asia and the developing world. But the paper remained the must-read publication for everyone connected with the world of fashion.

In 1968, the family decided to sell Fairchild Publications (which had grown to include trade papers dedicated to footwear, home furnishings, even electronics) to Capital Cities Broadcasting, thus becoming part of a publicly owned media empire. In 1986 *WWD* editors retired their typewriters and moved into the computer age. In 1991, Fairchild Publications moved from its woefully outdated Greenwich Village headquarters to modern offices in a more convenient, if less attractive, neighborhood across the street from the Empire State Building. John B. Fairchild retired in 1997 at age 70, naming Patrick McCarthy to be his successor as chairman and editorial director of Fairchild Publications. After a series of media mergers and acquisitions that gave Fairchild Publications various corporate parents in the 1980s and 1990s, the company was acquired in 1999 by Advance Publications Inc., the publishing empire (and publishers of *Vogue*), owned by the Newhouse family.

*WWD* remains one of the most influential voices in the world of fashion. It is famous as a sort of prep school for fashion journalists. Its alumni are on the masthead of almost every American consumer magazine, from *Condé Nast Traveller* to *Time*, although the concentration is heaviest, naturally, at fashion magazines. *New York Times* theater critic Ben Brantley and Bernadine Morris worked at *WWD*, as did former CNN correspondent Elsa Klensch, *Vogue* editor-at-large André Leon Talley, photographer Bill Cunningham, former French *Vogue* editor Joan Juliet Buck, and even Calvin Klein, who had a brief, unsuccessful stint as a copy boy in 1961.

See also **Fashion Advertising; Fashion Editors; Fashion Icons; Fashion Industry; Fashion Journalism; Fashion Magazines; Fashion Photography.**

#### BIBLIOGRAPHY

Agins, Teri. *The End of Fashion: How Marketing Changed the Clothing Business Forever*. New York: Quill, 2000.

Kelly, Katie. *The Wonderful World of Women's Wear Daily*. New York: Saturday Review Press, 1972.

*Janet Ozzard*

**WOOL** Wool is one of the oldest textile fibers used by humans. The term wool is generally used to describe fiber obtained from sheep or lambs. Legally the hair of a few other animals can also be called wool because its qualities are similar to sheep's wool. The United States government allows the fiber from alpaca, camel, llama, vicuña, Cashmere goat, and Angora goat to be labeled as wool, but these can also be labeled by their own fiber names.

Sheep were first domesticated in Central Asia about 10,000 years ago to provide a ready source of meat, milk, and hides for clothing. As humans worked with the hair from the sheep hides, they found that twisting thin strands of wool fiber together forms a continuous length of yarn. As time went on, they discovered that interlacing the yarn would form a fabric. Once yarn and fabric production were part of the knowledge base of humans, fabric became a second skin. The oldest surviving fragments of wool cloth were found in Egypt and date between 4000 and 3400 B.C.E.

The early, wild species of sheep had a two-layer coat. The coat closest to the body was a short wool undercoat of fine, downy fiber. This was protected by long, coarse

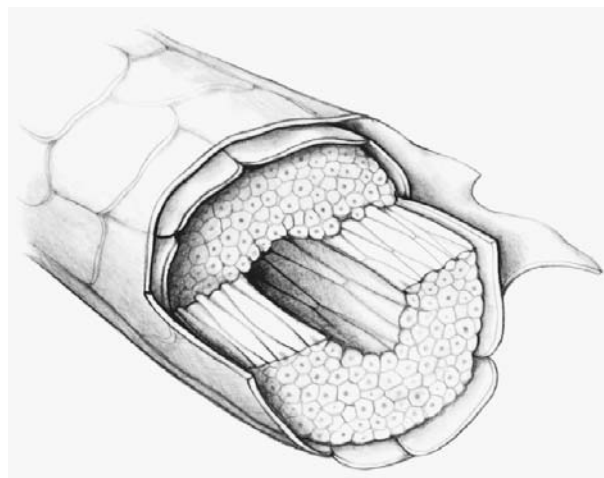

**Cross section of a wool fiber.** A wool fiber is made up of three layers: the cuticle, an outer layer of overlapping scales; the cortex which provides the bulk of the fiber; and the medulla, when present, is found in the middle of the cortex, and is a latticework of air-filled cells. REPRINTED WITH PERMISSION FROM *IN SHEEP'S CLOTHING* BY NOLA FOURNIER AND JANE FOURNIER. PUBLISHED BY INTERWEAVE PRESS, LOVELAND, COLORADO.

and straight guard hair. Since some sheep had better-quality fiber than others, people selected sheep for breeding that provided more undercoat and less guard hair. In the early 2000s, the majority of sheep growing wool for clothing produce mainly undercoat fiber.

A wool fiber is made up of three layers: the cuticle, cortex, and medulla. The cuticle is the outer layer of overlapping scales that comprises about 10 percent of the fiber. The cortex provides the bulk of the fiber, about 90 percent, and is composed of millions of long cells held together by a strong natural binding material. The cortex has two types of cells that behave differently to give wool fiber the characteristic "crimp" or waviness when a fiber is viewed from the side. The medulla, when present, is found in the middle of the cortex, and is a latticework of air-filled cells. A fiber with a large medulla is weak and doesn't dye easily.

#### Wool Production

**Shearing.** When human beings first used wool fiber, they gathered fiber that was shed from the sheep during their spring molt. As humans domesticated the sheep, they bred them to resist shedding so that the wool could be removed when it was convenient. In the early twenty-first century, the first step in wool production is removing the wool from the sheep by shearing (cutting). Once off the animal, the fleece of one sheep is bundled together with the clean side in.

**Grading and sorting.** Each fleece is examined, graded, and sorted. The tangled and dirty parts of the fleece are



#### TEASING OUT THE MEANING OF WOOL FIBER TERMS

**Hair vs. Wool:** Technically, hair differs from wool.

Hair is a coarse and straight fiber, whereas wool is a fine and crimped fiber with a scaly surface.

**Fur fiber vs. fur:** Fur fiber describes the hair of any animals other than sheep, lamb, Angora goat, Cashmere goat, camel, alpaca, llama, and vicuña. If hair or fur fiber is attached to the animal skin, it is also referred to as fur.

**Fleece:** The coat of fibers from one sheep is called a fleece.



removed and the fleece is graded for fiber fineness (diameter), length, crimp (a uniform waviness), color, kemp (thick hair fibers that dye poorly), strength, and elasticity. The finest wool's diameter is between 10 and 20 microns (one micron equals 1/20,000 of an inch). Fine wool is soft, like the fiber in a cotton ball, and is most luxurious. Coarse wool tends to be stiff and bristly, making it best for carpet. The length of wool fiber varies from 1 to about 14 inches. Fine combing wools measure 2.5 inches or more in length and coarse wools around 1.5 inches. While there are as many colors of sheep as there are colors of dogs and cats, white is the most common and has been the most valued over time. Sorting separates the individual fleece into various qualities, with the shoulders and sides giving the best quality and the legs the lowest quality.

**Scouring.** Wool needs to be cleaned of natural impurities before it is processed further. Impurities include a greasy substance called lanolin that oils the wool fiber and helps the sheep's coat shed water. Other impurities are dirt, vegetable matter, and perspiration or suint (pronounced *swint*). The wool is scoured by washing it with a detergent solution that carries the oil and dirt away from the wool. If some of the lanolin is left on the wool fibers to provide water repellency, it is called *grease wool*.

**Blending.** Sorted fleeces of a particular quality are thoroughly mixed together, in order to obtain a desired consistency of wool quality. Other types of fibers, such as spandex or nylon, may be added during this step to achieve an intimate blending of the fibers before they are spun into yarn.

**Stock Dyeing.** Clean fiber can be dyed before spinning it into yarn. This is referred to as stock dyeing. Dyed fiber may then be blended to obtain a yarn with a *heather effect*, which has many colors of fibers.

**Carding.** In order for an even yarn to be made, the fibers must be separated, spread into a uniform thickness, and encouraged to lie relatively parallel with one another. The carding step produces a continuous strand of untwisted fibers that are eventually drawn into a finer diameter strand before twisting the strand into yarn.

**Woolen system.** When a soft, fuzzy texture is desired in fabric, the woolen system of yarn production is used. In this process, the fiber is carded several times. Wool fibers of differing lengths and types may be processed with this system. Cloth made from yarn spun on the woolen system is correctly referred to as woolen. Typical fabrics include tweeds, sweater knits, and flannel.

**Combing (worsted).** In order to get a smooth and uniform textured fabric, the fiber must go through the combing process. Combing makes the fibers straight, in a parallel order. It removes short fibers and almost all of the foreign matter from the fiber matrix. Combed yarns are finer, cleaner, stronger, and more lustrous than

carded yarns. Examples of worsted wool fabrics are gabardine and serge.

**Spinning.** The final step in the process of making yarn is spinning. This draws out the fiber mass, thinning it to the desired diameter, and then stabilizes the strand by twisting the fibers into a yarn.

**Yarn dyeing.** Coloring the wool in the yarn stage before it is woven or knitted into fabric is called yarn dyeing. Dyed yarn produces plaids, checks, and other color-effects in weaving and knitting.

**Weaving.** Interlacing two or more sets of yarns at right angles to one another forms a woven fabric. Both woolen and worsted yarns can be used in the weaving process. Fabrics made with woolen yarns can be classified as woolens, and those made with worsted yarns may be classified as worsteds.

**Knitting.** Inter-looping one yarn or a series of yarns forms a knitted fabric. Either woolen or worsted yarns may be used in the knitting process, but woolen yarns are most commonly used. Garments may be knit into shape or flat knitted fabric can be created, which must be cut and sewn into a garment.

**Piece dyeing.** After a fabric is woven or knitted, pieces of a fabric can be immersed in a dye bath to give color to that fabric. Piece dyeing generally results in a solid color fabric. If yarns of differing fibers are included in one fabric, multiple color effects are possible.

**Finishing.** A completed fabric needs additional treatment before being acceptable for use by consumers. Numerous finishes can be done to wool fabrics, including: mending to repair damage done in the weaving or knitting process, wet finishes to control shrinkage and to make the fabric more dense; napping to brush-up a fuzzy surface; and singeing (burning) to eliminate long yarn ends. Wool fabric is given a final press to smooth out the wrinkles from previous finishing processes.

### The Properties of Wool

The natural qualities of wool are the reason it has been continually used for thousands of years. Its superior properties have not been totally duplicated by textile scientists. Wool remains a masterpiece of nature and provides a standard by which other fibers are compared.

**Resiliency and elasticity.** Wool fiber is resilient and elastic. It can bend 30,000 times without breaking or being damaged. Its natural elasticity is due to the cortex cells that naturally coil like springs to form crimp. The elasticity makes it comfortable to wear, because it conforms to the shape of the body and helps wrinkles disappear from wool garments when they are allowed to rest. Wool's resiliency is shown when it stretches and returns to its original shape. Dry wool fiber can be stretched about 30 percent without any damage. Wet wool can

stretch between 60 and 70 percent, but is weaker, so washed wool must be handled carefully. The resiliency of wool helps it to wear longer and maintain its good appearance longer than many other fibers.

**Comfort.** Wool clothing provides superior comfort during both hot and cold weather. Its complex cellular structure enables it to absorb water vapor, but repel liquid. As wool absorbs the body's water vapor, a dry layer of air is left next to the skin to hold in body heat, thereby keeping the body warm. The crimp in the wool fibers keeps each fiber apart from one another, resulting in little pockets of air trapped between the fibers. This trapped air acts as a very good insulator.

Wool is comfortable in hot weather because it helps keep the body cooler by absorbing perspiration vapor from the body. The evaporation of perspiration allows the body to naturally cool. The crimp that helps keep the body warm in cold weather blocks out much of the outdoor heat with its insulating barrier of air pockets. This helps the body maintain an even temperature.

Wool's insulating properties protect against sudden changes of temperature and let the body breathe. While wool can absorb moisture, it repels liquids. The scales on the outside of the fiber keep the liquid on the surface of the wool fabric. If it rains, it will take some time before the raindrops penetrate wool clothing, so wool keeps the wearer drier. When wool eventually gets wet it releases the heat and keeps the wearer warm. Wool can absorb up to 30 percent of its own weight in moisture before feeling really damp.

**Flame resistance.** Wool is naturally fire resistant because it absorbs water vapor from the air. While wool will eventually burn, it will not support a flame. Once the flame source is removed, wool self-extinguishes and an ash is left that can easily be brushed away. Wool does not melt when burned, so it won't stick to the skin.

**Resistance to static electricity.** Because of wool's ability to absorb moisture from the air, its tendency to build-up static electricity is low. Wool garments are less likely to "spark" and cling to the body. Wool resists dirt and stays cleaner longer than other materials because static electricity doesn't attract dust from the air. Furthermore the scales of the wool keep dirt from penetrating the surface. These same qualities make wool easier to clean.

**Felting.** Felting occurs when wool fibers interlock with each other when they are subjected to a combination of heat, moisture, pressure, and agitation. The scales lie in one direction on the fiber, making it move more easily in one direction than another. This is the differential friction effect (DFE). As wool fiber is moistened, rubbed, and warmed, the fibers' scales become locked together. Felting allows wool fiber to be made directly into a fabric without first being made into a yarn. It also allows wool fabrics to be finished with a process called "fulling," a con-

trolled form of felting. "Fulling" makes a fabric thicker and more densely packed. Wool's ability to felt makes it tricky to wash, as heat, moisture, and agitation will encourage felting and permanent shrinking will occur.

See also **Alpaca; Angora; Camel Hair; Mohair; Worsted.**

#### BIBLIOGRAPHY

Fournier, Nola, and Jane Fournier. *In Sheep's Clothing: A Hand-spinner's Guide to Wool*. Loveland, Colo.: Interweave Press, 2001.

Harmsworth, Tom, and Graham Day. *Wool and Mohair*. 2nd ed. Victoria, Australia: Inkata Press, 1990.

Kadolph, Sara J., and Anne L. Langford. *Textiles*. 9th ed. Upper Saddle River, N.J.: Prentice Hall, Pearson Education, 2002.

Ryder, Michael L., and S. K. Stephenson. *Wool Growth*. London and New York: Academic Press, 1968.

#### Internet Resources

The American Wool Council. *Wool Fabrics Fact Sheet*. Available from <<http://www.sheepusa.org/wool/genwool/woolfabrics.html>>.

Federal Trade Commission. *Threading Your Way Through Labeling Requirements Under the Textile and Wool Acts*. Available from <<http://www.ftc.gov/bcp/conline/pubs/buspubs/thread.htm>>.

The Woolmark Company. *Natural Properties*. Available from <<http://www.woolmark.com/about/naturalproperties.html>>.

*Ann W. Braaten*

**WORKING-CLASS DRESS** For much of the period between the eighteenth century and the present, most people in western countries could be characterized as working class. Many occupations and styles of living are encompassed, ranging from independent skilled artisans in regular work to unskilled laborers or the unemployed. Despite a numerical majority and their central place in social, cultural, and economic history, working-class people, like women as a group, until recently have been hidden from written history and their clothing has been overlooked or subject to only generalized or romanticized interest. What they wore also remained under-represented in museums, due to a low survival rate caused by the thrifty reuse of clothing or its worn-out condition, and the tendency of museums to collect and preserve elite fashions rather than utilitarian clothing. In the early 2000s there is widespread interest in occupational dress, the clothing of the poor, and the role of working-class clothing consumption in the development of a consumer society during this period. Academic studies in this field make use of an array of sources including inventories, court records, and household accounts to pursue this interest in the earlier part of the period and the use of oral history, film, and photography helps ensure the more recent past is better documented.



"Everybody knows that good clothes, boots or furniture are really the cheapest in the end, although they cost more money at first; but the working classes can seldom or never afford to buy good things; they have to buy cheap rubbish which is dear at any price" (Tressell, p. 296).

### Occupation, Social Position, and Clothing

One of the most marked gulfs between the appearance of working people and their employers was the use of livery for retainers and household servants. This practice of providing uniform clothing in the colors and style of a particular household was used to augment wages, and it served to embody hierarchy by distinguishing between employees and employer and between ranks of employees themselves. Livery was in widespread use during the period, as it had been since medieval times. It was far from universally popular with its recipients. By the nineteenth century it had become archaic in appearance, such as breeches and wigs for footmen, and had become very limited in use. It has been superseded to some extent by corporate uniforms. Domestic service was a major employer of women until World War I and generated styles of clothing representative of moral and practical notions of order and cleanliness.

Working people in the eighteenth and nineteenth centuries who did not get livery or other clothing as part of their employment often struggled not only to clothe themselves and their families at a basic level, but also to keep up certain levels of cleanliness and respectable appearances on which their continuing employment or their participation in local and church life depended. However, throughout these centuries, employers and the elite, in general, expressed anxiety about the consumption of clothing by working people. Increasing use, more styles, and a variety of available textiles, and the so-called democratization of fashion were judged to weaken conventional distinctions between social classes. Expenditure on clothing by working people was thought to indicate potential extravagance, vanity, and improvidence. There were numerous Victorian cartoons mocking both the domestic servant and her employer as the servant appeared in stylish crinolines or other finery. This was frequently observed in Britain, where social distinctions in dress are thought to have prevailed for longer than in the United States. In the twentieth century, new synthetic materials, simpler styles, affordable fashion magazines, dance halls, and the cinema especially, spurred greater access to fashionable clothing for working women. More recent adoption of homogeneous leisure wear means that social distinctions may be less visible than ever before outside work.

### Working Clothes and Fashion

Modish and symbolic use of working-class dress entered general consumption in various ways and in general over the last three centuries; there has been a significant flow of garment types and textiles from utilitarian and occupational clothing into fashion. Examples include appropriation of military combat styles into everyday wear and the rough and thorn-proof warmth of local Scottish and Irish tweeds that were adopted for fashionable urban use in Victoria's reign. Sailors wore "trowsers" long before they entered fashionable male wardrobes. What was produced in nineteenth-century America as denim work wear for men is, in the early 2000s, universally available as fashionable leisure wear for men, women, and children alike and authentic antique jeans command high prices among collectors.

Doc Marten boots had a similar pattern of appropriation and cult status. English agricultural smocks of the nineteenth century were adopted and revived as artistic dress, popularized by Liberty's for well-off urban women and children at the end of the century, echoing nostalgia for a largely imagined idyll of rural England.

Politicians have made use of the symbolic value of materials or garments associated with working-class life, such as when Keir Hardy, elected as one of Britain's first working-class members of parliament, insisted on wearing a rough-spun tweed suit and a flat wool cap instead of the more formal garb usually seen in parliament. President Lyndon Johnson famously wore a cowboy hat to signify his allegiance, and President Jimmy Carter often wore a sweater rather than more formal attire.

In the arts, performers and actors such as Dolly Parton, James Dean, Marlon Brando, and Charlie Chaplin have used working and utilitarian dress to powerful effect. Subcultures, as disparate as Hell's Angels, hippies, punks, and New Agers, have often demonstrated their nonconformism by blending garments from a variety of sources, including working clothes. In the 1970s many pioneer feminists adopted dungarees as a sartorial rejection of fashion and conventional gender roles.

The making and wearing of replica working clothing from the past has become widespread through the popu-



"To imagine New York City in 1789 is to conjure up...tattered beggars, silk-stockinged rich men, pomadoured ladies and their liveried footmen, leather-aproned mechanics and shabby apprentice boys, sleek coach horses, pigs...where the riotous world of the labouring poor surrounded a small, self-enclosed enclave of the wealthy and urbane" (Stansell, p. 3).



larity of historical reenactment and the use of living history to interpret historic sites. The shift such clothing makes in its esteem and value may have no single explanation; rather, it may embody a complex range of social, cultural, and economic factors over time. Mass production of clothing, urbanization, and more recently, new attitudes to work and leisure, money, and credit, may change not only our clothing but the identities they represent.

### Provision

Before the advent of systematic state support in the twentieth century, various local or parish bodies and charitable organizations took responsibility for those unable to help themselves, and clothing for such men, women, and children was often part of the provision. Outside this framework, provision was uncertain because it was dependent on income, locality, and luck.

Secondhand clothes were an important element in the clothing strategies of working people. These could be obtained as cast-offs from employers, or from markets and specialist shops in urban areas. There were large warehouses buying and selling secondhand clothing in bigger cities by the eighteenth century, and Henry Mayhew describes a vibrant trade in the wholesale and export of old clothes in 1850s London.

Where women possessed adequate sewing skills, much clothing was made over or recycled: For example, children's clothes were made from cut-down adult garments. The pawning of best clothes played a central part in many household economies. This provided regular cash, and often clothes left all week in the pawnshop were stored in better conditions than was possible in damp or overcrowded homes. In many working households, mothers were traditionally in charge of the budget, and there is evidence that they often clothed and shod working husbands, sons, and school-age children before meeting their own needs.

Sewing clothes at home was assisted by the advent of the sewing machine and effective paper patterns from the 1860s onward, but these were unaffordable for many women. Others sewed at home to earn cash by making or renovating garments for local customers.

Theft played its part in the provision of clothes for use or resale, and in the eighteenth century there are numerous records of vanished household servants who took quantities of clothing with them to pawn or sell. Peddlers traveled around selling clothing, accessories, and cloth to individual households in the eighteenth century before communications and transport improved.

Many working people continued to clothe themselves and their families in ways more suited to their circumstances than traveling to expensive shops. Local or workplace clothing clubs and, by the mid-nineteenth century, mail order with payment by installments played an important part in enabling them to be adequately and fashionably clothed.

Huge markets for slops and utilitarian clothing, including uniforms for the military, led to the development of the mass manufacture of ready-mades from the eighteenth century onward. In America the manufacture of jeans for men demonstrates the growth of factory-based specialist clothing companies. As urbanization coupled with expanding markets during the nineteenth century, new jobs grew up in service industries such as banking and insurance, which resulted in large numbers of low-paid white collar jobs for men and women. A big manufacturing sector developed for affordable clothes for this work, such as suits, blouses, collars, and shoes, which could be widely distributed through growth in urban retailing.

### Specific Modes and Items

The common utilitarian dress for laboring men before the twentieth century was made up of breeches or trousers, jackets, and waistcoats of hard-wearing materials such as moleskin, fustian, or corduroy. In some situations, working women were the first women to don breeches or trousers. This occurred in the second half of the nineteenth century in Britain (in pits and mines, in work associated with fishing, and in brickworks), and in the United States (where women did agricultural work), and in some utopian communities.

In many manual occupations, until shorter skirts were widely accepted, women simply hitched up long skirts in various ways. Commonly, in many countries, they wore aprons and woolen shawls. In eighteenth- and early nineteenth-century Britain, the red woolen, hooded cloak was commonly worn by rural women. Women used boots instead of shoes; pattens and then clogs were valuable assets for workingmen and -women on dirt roads and later in factories and mills. Stout and durable footwear has always been a major investment for those undertaking physical labor. Similarly in the United States, denim became widely used by the second half of the nineteenth century for tough work by cattlemen, on the railways and in the mines. Roomy and rugged work shirts accompanied these. Leather and suede have been used in working garments for centuries and persists to the present day, providing hard-wearing and durable covering in the form of aprons for blacksmiths and chaps, gaiters, gloves, and various specialist items and outerwear for other occupations.

Although Britain differed from continental Europe in having no recognizable regional folk dress, two agricultural garments stand out as characteristic of rural workers, and these were worn either at work or as Sunday best. These were smocks for men, from the eighteenth century onwards, which provided a measure of protection and warmth; and the cotton sunbonnet for women, which was decorated with tucks and piping and had strikingly long panels to protect the neck. Fishermen have always had special clothing needs to protect them against the elements. In this context, oilskin was developed in the nineteenth century, and the woolen hand-knitted, close-fitting and ornamented upper garment for fishermen known variously

as a gansy, jersey, Guernsey, knitfrock, and later sweater or jumper, became associated with the island fishing communities of Britain. Versions of it were later widely adopted as warm, informal attire for both sexes.

Occupational dress evolves as new occupations emerge, and innovative protective elements are introduced as new risks appear. In the industrializing period, boiler suits accompanied the use of steam power, and since the advent of forms of power that propel us into alien environments, special forms of clothing have been developed for, among others, pilots, divers, and astronauts. To an extent, occupational dress has often represented social and local or regional identities. In this sense, it has shown more style and commanded more loyalty than is strictly utilitarian. In 2002 in northern England a local bus driver was fired for refusing to exchange his habitual cloth cap for a baseball-style company cap. The dramatic fantail hats of the garbage collectors of early nineteenth century England or the intricate patterning on fishermen's knitwear have all testified to expressive and creative elements in occupational dress.

See also **Secondhand Clothes, History of; Uniforms, Occupational.**

#### BIBLIOGRAPHY

- Crane, Diana. *Fashion and its Social Agendas: Class, Gender and Identity in Clothing*. Chicago: University of Chicago Press, 2000.
- De Marly, Diana. *Working Dress: A History of Occupational Clothing*. London: B. T. Batsford, Ltd., 1986.
- Hall, Lee. *Common Threads: A Parade of American Clothing*. London: Little, Brown and Company, 1992.
- Kidwell, Claudia, and Margaret Christman. *Suiting Everyone: The Democratization of Clothing in America*. Washington, D.C.: Smithsonian Institution Press, 1974.
- Partington, Angela. "Popular Fashion and Working-Class Affluence." In *Chic Thrills: A Fashion Reader*. Edited by Juliet Ash and Elizabeth Wilson. London: Pandora, 1992.
- Quennell, Peter, ed. *Mayhew's London: Henry Mayhew*. London: Bracken Books, 1984.
- Severa, Joan. *Dressed for the Photographer: Ordinary Americans and Fashion, 1840–1900*. Kent, Ohio, and London: Kent State University Press, 1995.
- Stansell, Christine. *City of Women: Sex and Class in New York 1789–1860*. Urbana: University of Illinois Press, 1987.
- Textile History. Special Issue on the Dress of the Poor*. Vol. 33, no. 1 (May 2002).
- Tressell, Robert. *The Ragged Trousered Philanthropists*. London: Flamingo, 1993. The original edition was published in 1914.

Barbara Burman

**WORSTED** The term "worsted" identifies a yarn that has been processed on the worsted spinning system. This system of yarn production is designed to work with staple fiber lengths that range from 2.5 to 7 inches. It was originally designed for processing wool, but in the early

twenty-first century any fiber or fiber blend of the appropriate length can be processed. This system of yarn production can utilize fibers with diameters that range from fine to coarse. While worsted wool in apparel fabrics generally uses fine diameter wool, worsted fabrics can use any diameter fiber so can vary in quality. "Worsted" also refers to a fabric woven from yarn processed on the worsted spinning system.

Both worsted and woolen spinning systems include the steps of opening, blending, carding, drawing, and spinning. Opening separates the fibers from their compact state. Blending mixes fibers from different fleeces to get a fixed level of quality. Carding works to organize the fiber into an even and fairly parallel strand. Drawing pulls the fiber into the desired diameter. Spinning twists the strand to hold the fibers in place.

What makes the worsted spinning system differ from yarns made on the woolen spinning system is an extra step in the yarn manufacturing process called "combing" or "gilling." To visualize what happens in the combing process think of the difference between brushing and combing tangled hair. The combing action removes snarls, short fibers, and any other waste matter from the fiber matrix. The short fibers are called *noils* and are recycled by blending them into woolen yarns. Combed yarns have their fibers lying parallel with each other, like spaghetti before being cooked. When the fibers are in this arrangement, they can be pulled to form a very thin yarn. This compact orientation and uniformity in fiber length makes worsted yarn smoother and stronger than similar yarns made on the woolen spinning system.

The worsted spinning system was originally developed in the English city of Worstead. (The term "worsted" is a Middle English derivation of the city's name.) The term "woolen" should not be used to describe worsted yarns or fabrics, as woolen refers to yarns manufactured on the woolen spinning system.

Worsted wool fabrics vary from woolen fabrics in several ways. Wool will be comfortable to wear in the hot summer months if the fabric is made with worsted wool yarns, as they are thinner and flatter yarns that trap less air than fuzzy woolen fabrics. The smooth surface helps worsted wool fabric repel soil and lint better. Worsted wool fibers will not shed from the fabric because the short fibers were removed in the combing step, unlike woolen fabrics. Worsted fabrics are longer wearing and stronger than woolen fabrics. They are also lighter weight than woolens, and will not sag.

Worsted wool fabrics for apparel can range from sheers to suitings. Worsteds made of fine diameter wool will provide sleek fabrics that show design details, and will take and hold a crisp press. Some common examples of worsted wool fabric include tropical worsted, wool crepe, wool broadcloth, wool gabardine, and wool serge. The word "worsted" may be pronounced in two different ways, *woo-sted* and *wer-sted*.

See also **Wool**; **Yarns**.

#### BIBLIOGRAPHY

James, John. *History of the Worsted Manufacture in England*. London: Cass; New York, A. M. Kelley, 1968.

*Ann W. Braaten*

**WORTH, CHARLES FREDERICK** Four generations of Worths are associated with perhaps the most enduring name in fashion history. Indeed, without the house's contributions to fashion, the French Second Empire would not be remembered as an unending parade of luxurious confections in women's dress, and the Gilded Age would not seem so golden.

Charles Frederick Worth (1825–1895) was the founder of a fashion house usually credited with establishing the highest level of fashion creativity: *haute couture*. Originally the French phrase meant the highest level of sewing. Later it was employed to identify that portion of fashion—particularly French fashion—that both exemplified the pinnacle of dressmaking techniques and produced new styles. Unfortunately, the phrase *haute couture* has lost its original meaning through overuse.

#### Early Career

Charles Frederick Worth was uncommonly astute in recognizing that his talents were better directed toward artistic creativity rather than managing a business. Following a period of working in London dry-goods shops, Worth set out for Paris. In 1846 he found a position at the prominent dry-goods and dressmaking firm of Gagelin et Opigez. This position gave Worth the experience that later enabled him to build his own business. At Gagelin he was exposed to the best resources for fabrics and trims, and allowed to develop his design skills. He also learned the value of live models and met his future business partner, a Swede named Otto Bobergh (1821–1881). What eventually became the House of Worth was established in late 1856 or early 1857 as Worth and Bobergh at 7, rue de la Paix, with Worth as the artistic head and Bobergh as the financial director. The partnership dissolved in 1870–1871, when Bobergh decided to retire due to major political unrest in France.

Worth's wife, née Marie Vernet (1825–1898), was a former Gagelin model. Mme. Worth easily attracted the attention of the ladies of the French court and then the Empress Eugénie herself, by wearing Worth's creations. Taken with promoting French industries, including the once-dying silk industry of Lyon, the empress thrived on lavish gatherings and equally lavish dress at these events. The empress appointed Worth the court couturier in 1860. To make sure his house could keep up with the growing demand for his dresses, Worth introduced a new way of creating an outfit. Instead of designing a complete dress, he pioneered the concept of mixing and matching skirts



**Charles Frederick Worth.** Worth founded the House of Worth, which is credited as being the first producer of *haute couture*. THE LIBRARY OF CONGRESS. PUBLIC DOMAIN.

and bodices, which insured that ladies did not appear at a function in look-alike attire. Worth also developed interchangeable pattern pieces in constructing these garments, further insuring the uniqueness of a completed ensemble.

At the House, clients could preview evening attire in rooms illuminated by various forms of light—natural light, candlelight, gas lamps, and later, electric bulbs. While the House maintained the usual fitting and modeling rooms, it also offered rooms for fabric selection that were distinguished by color. An understanding of the play of colors and textures was one of the enduring achievements of the House, and was successfully passed from generation to generation. Charles Worth's sense of color was particularly noteworthy—he preferred nuanced hues to bold primary colors.

#### Merchandising Innovations

Throughout the House of Worth's existence, it catered to the rich and titled, although it also served those of more limited means. Garments could be ordered from afar with no personal fittings required. The client supplied a comfortably fitted garment from which appropriate measurements were taken. Worth's models also could be made from commercial paper patterns. The House initially advertised its creations in obscure but aesthetically interesting nineteenth-century publications before entering the



mainstream at the end of the century with full-page images in *Harper's Bazaar* and *The Queen* as well as their French counterpart *La mode illustrée*. In the twentieth century, the House's models were advertised in such selective fashion publications as the *Gazette du bon ton*, and such newer entries as *Vogue*. The former type of publication carried on the centuries-old tradition of hand-drawn and hand-colored illustrations, while the latter featured modern photographs.

Late-nineteenth-century publicity images of Charles Frederick Worth depict a man who saw himself as an artist, wearing a bow at the neck or a beret. Many of the images of his son Jean-Philippe also show someone intent on conveying an impression of creativity. Like many classically trained painters and sculptors of their day, the Worths drew on historical prototypes. The House's designs included references to garments in historical paintings gleaned from museum visits, published descriptions of works of art, and personal familiarity with historic costume. Large numbers of Worth garments from the period of Charles and Jean-Philippe referenced seventeenth- and eighteenth-century styles, but none of them will ever be confused with their prototypes, thanks to construction detail and fabric choice. The Worths employed several distinguishing features in their garments beyond the waistband label that they first introduced in the mid-1860s. Although often credited with the innovation, Worth was not the first dressmaker to use a label. The earliest Worth examples were stamped in gold, but they became a woven signature in the late 1870s. This signature label would last the duration of the House. Attempts to defraud the public with spurious labels were made, especially in the United States in the early twentieth century.

### Dress Construction and Materials

Contrary to Worth family mythology, the vast majority of the House's garments were trimmed with machine-made rather than handmade lace. Many Worth clients had collections of lace that had been acquired as investments. Sometimes such lace was used on a garment but almost always removed later and returned to the client. The same procedure was followed if gemstones were incorporated into a garment's design. An additional feature employed by the House was the use of selvage as a decorative touch as well as functional finishing.

Perhaps the House's most important contribution was the type of fabrics that it employed. Following the collapse of the Second Empire in 1870, Worth became an even more important client for the textile and trim producers of Lyon and its environs. There is evidence that Worth both used preexisting yard goods and worked with manufacturers to come up with patterns for new materials.

Charles Worth had begun his designing career by following the expansion of women's skirts in the 1850s, when they were supported by layer upon layer of petticoats. In the later 1850s Worth draped yards of fabric

over the skirts' increasing width, as the newly devised crinoline cage, or hoop, permitted expansion without increased bulk. Many Worth dresses from this period, sadly, were frothy, cloudlike confections in silk tulle that have now melted into oblivion. An impression of their impact, however, can be seen in portraits by such artists as Franz Xaver Winterhalter.

Worth introduced hooped dresses with flatter fronts in the early 1860s. It is evident, however, that he was careful not to diminish the amount of material needed; he merely pushed the fabric to the back of the dress. During this decade Worth is also credited with developing the princess-cut dress. These less expansive styles posed an economic challenge. Having been trained in dry-goods shops, Worth recognized the danger of weakening trades that contributed to the success of his own business. Therefore he had to either incorporate large quantities of material into his garments or support the production of costlier luxury goods. In order to maintain a high level of consumption, the House moved material throughout much of the 1870s and 1880s from draped overskirts to trains, bustled backs, and a variety of combinations of these styles. Just as the Empress Eugénie's patronage of the French textile industries had been crucial before 1870, so also was Worth's business vital for the looms of Lyon and Paris that created spectacular luxury materials afterward.

Many of the House's early garments had been constructed of unpatterned silks—tullies, taffetas, reps, and satins—or nominally patterned fabrics featuring stripes and small floral sprays—in other words, typical dress goods. Beginning in the 1870s, almost as a move to fill the void left by the departed French court, the house increasingly employed more expensive textiles usually associated with household furnishing in its garments. Worth boldly utilized grand-scale floral motifs designed for wall coverings in garments whose skirts were often not long enough to include a full repeat of the pattern. Such luxury fabrics, exhibiting astonishing richness of material and the highest level of technical skill, were a feature of the House's models into the first years of the twentieth century. With the exception of machine-made laces, Worth's trims and embroideries matched the ground fabric to which they were applied. The consensus among Worth's clients was that these costly toilettes were worth the price.

Charles Worth and his house did not merely purchase materials; they are also known to have worked closely with textile manufacturers. From such concerns as A. Gourd et Cie, J. Bachelard et Cie, and Tassinari et Chatel, the Worths either commissioned specific designs or ordered preexisting patterns. Often the fabrics they chose had been displayed at important international exhibitions. Many of the fabrics found in late-nineteenth- or early-twentieth-century Worth garments feature subjects that were especially popular with the House: feathers, stalks of grain, stars, butterflies, carnations, iris, tulips, chestnut and oak leaves, scallops and scales, and bowers of roses.

### The First Couturier

Worth was not the first man to be an acclaimed creator of fashion. LeRoy had been held in similar esteem as a milliner and dressmaker to the Empress Josephine. Worth was, however, the first clothing designer to be called a couturier. Nevertheless, Worth had the good fortune to be a man entering a field that had become dominated by women, a position that automatically made him a curiosity in the 1850s. During the heady days of the Second Empire, the magic of the “man milliner” called Worth drew the fashion-conscious to the rue de la Paix. Worth’s clients were decried as slaves to this dictatorial monarch. Nor was it lost on the House that the theater was an active agent for the propagation of fashion. Even when dressing actresses of the stature of Sarah Bernhardt, however, Worth would insist on full payment for garments. British actress Lillie Langtry was a faithful client, as were such other *grandes horizontales* (courtesans), actresses, and opera stars as Cora Pearl, Eleanora Duse, and Nellie Melba. Such Bostonians as Lillie Moulton, Isabella Stewart Gardner, and Mrs. J. P. Morgan were dressed by the House, as were their counterparts of the Vanderbilt, Astor, Hewitt, Palmer, McCormick, and Stanford families in New York, Chicago, and San Francisco. The House dressed members of the royal families of Russia, Italy, Spain, and Portugal as well as the noblewomen of numerous German principalities.

The first challenge to the house’s primacy came with the founding of the House of Paquin in 1891. During the 1890s Worth began to lose clients to this concern. An analysis of the order numbers found in late nineteenth- and early twentieth-century garments reveals not only the year of manufacture but also the fact that orders were declining during this period. But for nearly fifty years, however, a Worth garment had been the most coveted of all apparel, particularly among American women. Perhaps this popularity developed because women from the United States felt at ease discussing their dressmaking needs with a man who could speak English. In return, Charles Worth appreciated his American clients because they had faith in him, figures that displayed his creations to advantage, and perhaps most importantly—francs to pay his bills.

### Worth’s Successors

Charles Frederick Worth was officially succeeded on his death by his sons Jean-Philippe and Gaston, who had established important roles within the House in the 1870s. Jean-Philippe (1856–1926) worked as a designer alongside his father, and Gaston (1853–1924) functioned as business manager. Throughout the years and over the span of four generations, the Worths never lost sight of the need for astute financial as well as artistic direction.

During the period when Charles and Jean-Philippe worked together as designers within the House it is im-

possible to separate their designs. Even though later house labels carry the signature of the elder Worth, others may have been responsible for the garment’s inspiration.

World War I and the subsequent devaluations of European currencies were particularly devastating to the Worths, because the house had dressed so many female members of the royal families of Europe. In addition, many of the House’s older clients died during this period, while fashions were making the transition from Edwardian modes to jazz age styles. When Jean-Philippe and Gaston retired in the early 1920s, they were succeeded by Gaston’s sons; Jean-Charles Worth became the new designer, and his brother Jacques the financial director. Jean-Charles easily moved the House’s designs from the more staid yet elaborate models of the prewar period into the simpler and more practical styles of the 1920s. In the process, however, fewer and fewer of the characteristics that had been exclusively associated with the House’s production can be discerned in the garments that survive from this period.

Worth’s grandsons were followed in the 1930s by his great-grandsons Maurice and Roger, the latter assuming the couturier role. They attempted to breathe new life into the House; in 1936 they moved the Paris store to 120, rue du Faubourg St.-Honoré. At the end of World War II, however, both the London and Paris branches of the house merged with Worth’s old rival Paquin. The London branches, the first established in 1911, survived the Paris branch by eight years. Worth’s heirs also shuttered the branches of the House that had been established in Cannes and Biarritz.

As of the early 2000s, the Worth name survived in perfume, although the company has long been out of direct family control.

*See also* **Crinoline; Fancy Dress; Fashion Marketing and Merchandising; Haute Couture; Paquin, Jeanne; Paris Fashion; Perfume; Royal and Aristocratic Dress.**

### BIBLIOGRAPHY

- Coleman, Elizabeth A. *The Opulent Era: Fashions of Worth, Doucet and Pingat*. New York: The Brooklyn Museum in association with Thames and Hudson, 1989.
- De Marly, Diana. *Worth: Father of Haute Couture*. 2nd ed. New York: Holms and Meier, 1990.
- Saunders, Edith. *The Age of Worth*. London and New York: Longmans, Green, 1954.

### Internet Resources

- Charles Frederick Worth Organization. Available from <<http://www.charlesfrederickworth.org>>.
- House of Worth. Available from <<http://www.houseofworth.co.uk>>.

*Elizabeth Ann Coleman*



**XULY BËT** The Paris-based African fashion designer Lamine Kouyaté is the creator of the XULY.Bët brand. The company is best known for its use of recycled clothing to create high fashion, reshaping found garments by cutting, stitching, and silk-screening, or making modifications that range from the subtle shaping of a seam to the complete transformation of a garment's function. XULY.Bët's recycled clothing embodies several seemingly contradictory attributes: simultaneously mass-produced and unique, new and old, African and European, exclusive and accessible, emerging out of the rarified fantasy of fashion runways and the gritty practicality of the streets. This work turns the notion of haute couture inside out, since it relies on the creation of garments that are one of a kind because they are made of used clothing that has been discarded.

### **Personal Background**

Lamine Badian Kouyaté is the product of the cosmopolitan African culture of both urban Africa and the African diaspora. He was born in Bamako, the capital of the West African country Mali, in 1962. His father was a government minister in the first postcolonial administration, and his mother was a doctor from Senegal. Kouyaté's father was imprisoned during the 1968 coup d'état, when President Modibo Keita was overthrown by Moussa Traoré, who led a repressive, dictatorial government until 1992. The family left the country, moving to Paris when Kouyaté was fourteen, then to Dakar when he was sixteen, where his father worked for the United Nations. Dakar and Bamako are cosmopolitan centers whose cultural influences draw upon African, European, American, and myriad other sources. Kouyaté described the global perspective of youth culture in the African cities: "I knew more about rock and funk in the 70's than any of the kids in Paris when I got here" (Spindler, p. 1). At age twenty-four, he left Dakar to study architecture at the University of Strasbourg in France.

Before completing his architecture degree, Kouyaté moved to Paris and began working as a clothing designer. He founded his XULY.Bët label in 1989. Kouyaté's background in architecture may in part explain his tendency to reveal and rework the structure of garments, often by disassembling them at the seams. Kouyaté's fashion sen-

sibilities were also shaped by his interests in music and performance. He participated in the underground Parisian music and nightclub scene of the early 1980s and, as part of that environment, began designing clothes for performances and for his friends in the clubs. He continues to perform as a musician with his band, "This Is Not A Machine Gun." His attention to the expressive potential of music and performance continues to be manifested in his work, including most notably his presentation of designs at fashion shows.

### **Recycled Clothing**

Kouyaté's line of recycled garments debuted in 1992 as part of the first major collection of the XULY.Bët brand. The garments were made of previously owned shirts, sweaters, dresses, pants, hosiery, and other clothing purchased in flea markets, charity shops, and low-end department stores. Kouyaté altered each garment, responding to the fabrics and the shape of the piece, cutting, removing, and restitching seams using bright red thread. His energetic technique is preserved in the threads left hanging at the end of seams, their red hue emphasizing the process of transformation from discarded garment to designer statement. Kouyaté's reshaping of garments includes the transformation of dresses into skirts, skirts into bags, stockings into halter tops, and sweaters stitched together to create dresses.

The previous lives of XULY.Bët recycled garments are deliberately preserved; Kouyaté leaves the original labels in the collars of used shirts and the waistbands of pants purchased at flea markets. These labels provide vivid evidence of the histories of clothing that has been used, discarded, and later returned to the fashion market by the designer. The original label alludes to the garment's first life; the bright red XULY.Bët label, usually placed on the outside of the garment, declares its current identity. The used garments Kouyaté works with provide an endless source of constantly changing raw material, like an archaeological record of past styles that are reintroduced into the fashion market.

### **Rethinking the Fashion Show**

XULY.Bët's first major fashion show, held during the spring 1992 season in Paris, illustrates Kouyaté's interest



in the tension between the theatrical and the mundane. His debut fashion show's innovative staging emphasized the brand's raw, edgy aesthetic. Kouyaté presented the show outside the conventional precincts of the fashion industry, at a public park. He did not use a runway or a sound system. Instead, models emerged from a bus that pulled up at the site, each carrying a boombox that provided her own soundtrack to the event. No stage, no lights, no delineation of theatrical space separated the audience from the performers, just as the garments themselves were but subtly separated from their previous, mundane lives.

### African Elements

Kouyaté's work incorporates aspects of his own biography, which encompasses contemporary, urban Africa as well as the fashion worlds of Paris and New York. His company's name draws immediate attention to his African origins. In Oulouf (or Wolof), the predominant language of Senegal, *xuly bët* is a colloquial term that can be roughly translated as "voyeur," or, in a more nuanced definition, as someone who breaks through appearances to see the reality beneath the surface. This notion, peeling back the exterior to reveal the often uneven surfaces layered beneath, is embodied by Kouyaté's exposed seams and loose threads. He has cited his roots in Africa as an important source of inspiration for his recycled fashion, reflecting a widespread African ethic of reusing resources that is born out of necessity. Kouyaté draws on Africa in a more literal sense, using African fabrics in several of his designs and, in the early twenty-first century, working with dyers in Mali to create fabrics that he uses in his other clothing lines.

### International Presence

Kouyaté is among the few African designers to have achieved an international profile; XULY.Bët clothing and the designer himself have been featured in prominent

publications, including French *Glamour*, the *New York Times*, *Le Figaro*, and *Essence*. His clothing played a prominent role in Robert Altman's film *Ready To Wear* (1994), in which a fashion show in an underground subway station presents XULY.Bët clothing as the work of one of the film's main characters. The designer's personal background as well as his work drew substantial attention from both the fashion and the popular press, particularly in the early 1990s. In the early 2000s Kouyaté continued to design actively, marketing his clothing through several shops in Paris and for international clients.

*See also* **Fashion Designer; Fashion Shows; Recycled Textiles; Textiles, African.**

### BIBLIOGRAPHY

- Jacobs, P. "Xuly Bet: A Brother from the 'Mother' Turns Fashion Inside Out." *Essence* 15 (May 1994): 26–27, 144. Introduction to Kouyaté's background and his work, with several illustrations.
- Renaux, P. "Pari Dakar de Xuly Bët." *Glamour* (April 1994). Focuses on the designer's African background, documenting a trip home to Dakar to visit his family.
- Revue Noire* 27 (March 1998). Special issue on African fashion includes a large spread devoted to XULY.Bët, with generous illustrations of his recycled line of clothing. An important publication for readers seeking insight into African fashion design as an international phenomenon.
- Spindler, A. M. "Prince of Pieces." *New York Times* (2 May 1993): section 9, pp. 1, 13. Most substantive coverage of the designer available, including an overview of his career and extensive quotations from interview with Kouyaté.
- Van der Plas, E., and M. Willemsen, eds. *The Art of African Fashion*. Lawrenceville, N.J.: Africa World Press, 1998. Kouyaté is one of a handful of African designers featured in this important publication. Several essays by academics and fashion practitioners situate African fashion design within global markets.

*Victoria L. Rovine*



**YAMAMOTO, YOHJI** Yohji Yamamoto is widely regarded as ranking among the greatest fashion designers of the late twentieth and early twenty-first centuries. He is one of the few in his profession who have successfully broken the boundaries between commodity and art, by creating clothing that ranges from basics like athletic shoes and denim jeans to couture-inspired gowns that are nothing short of malleable mobile sculptures. Lauded as a blend of master craftsman and philosophical dreamer, Yamamoto has balanced the seemingly incompatible extremes of fashion's competing scales.

Despite the magnitude of his talent and the importance of his work, however, Yamamoto has yet to be the subject of serious critical discourse among fashion journalists and historians. It is perhaps ironic that the only probing analysis of Yamamoto—both the man and the designer—came from someone who possessed little knowledge of or interest in fashion. Wim Wenders, the renowned German filmmaker, produced a documentary in 1989 entitled *Notebook on Cities and Clothes*. Throughout the film, Wenders dramatized Yamamoto's creative genius by setting the words of the late German philosopher Walter Benjamin against the urban backdrops of both Tokyo and Paris. Yet the director's probing failed to illuminate the crucial elements that constituted Yamamoto's fashions. Neither the elements particular to the art of dressmaking nor Yamamoto's particular aesthetic contributions were discussed.

Inspiration from the intangible, mainly images of historical dress from sources such as photographs, has been a mainstay in Yamamoto's work. The crumpled collar in a August Sander portrait, the gauzy dresses captured by Jacques-Henri Lartigue while vacationing on the Riviera, and the gritty realism of Françoise Huguier's travels among the Inuit of the Arctic Circle are but a few examples. It is not surprising that the riveting catalogs created for each of Yamamoto's high-end ready-to-wear women's collections have included the work of such notable photographers as Nick Knight, Paolo Roversi, Inez van Lamsweerde, and Vinoodh Matadin. Whether Yamamoto is evoking historicism via the ancien régime or the belle époque, or ethnic garments made of richly woven silks and woolens, he has come to epitomize the vast range of creative possibilities in the art of dress.

### Early Career

Yamamoto was born in Tokyo on 3 October 1943. He never knew his father, who died in Manchuria during World War II; he was reared by his widowed mother Yumi. A dressmaker by trade, Yumi suffered what Yamamoto recalls as the indignities of a highly skilled worker whose gender and station in life afforded her little opportunity to make a rewarding living or to obtain recognition for her talents. Yumi encouraged her son to become an attorney—he graduated with a law degree from Keio University but never practiced. The lure of becoming a designer, however, pulled Yamamoto into fashion.

After completing his university studies in 1966, Yamamoto studied fashion design at the famous Bunkafukuso Gakuin, a fashion institute in Tokyo. Despite his skills as a master craftsman, he started his career as an anonymous creator around 1970. Two years later he marketed his own designs under the label Y's. Clothing under this label is now considered to be Yamamoto's lower-priced, or "bridge," line. In 1977 he presented his Y's collection for the first time in Tokyo. Along with his compatriot Rei Kawakubo, he designed his first high-end women's ready-to-wear collection in 1981 and presented it in Paris. Over the next two years, Kawakubo and Yamamoto pioneered the idea of deconstructed fashions. Their revolutionary aesthetic shocked the world with clothing that appeared to be unfinished, tattered, and haphazardly put together. Yamamoto's loose, flowing silhouettes and ubiquitous use of black further enhanced his groundbreaking work, which became the favored look of the 1980s urban aesthetic. In 1984 Yamamoto presented a deluxe menswear line that incorporated many of these same elements.

### Yamamoto's Aesthetic

From the moment Kawakubo and Yamamoto presented their first fashion collections to an international audience in the 1980s, they were defined as Japanese designers. Virtually every article about them as well as the critical reviews of their collections began by describing them as inseparable from and encapsulated in their Asian heritage. Many journalists inaccurately assumed that they produced clothing worn by all Japanese people. The reality was that the loose, dark-colored, and seemingly tattered garments were as startling to the average Japanese as they

were to the Western audiences that first viewed them. Although Yamamoto's work changed and evolved over the next two decades, it retained several key elements—the ambiguities of gender, the importance of black, and the aesthetics of deconstruction.

**Gender ambiguity.** Yamamoto's professed love of and respect for women has not been evident to many because his clothes were often devoid of Western-style gender markers. He expressed an aversion to overtly sexualized females, and often dressed women in designs inspired by men's wear. Such cross-gender role-playing has long been a part of Japanese culture, and a persistent theme among performers and artists for centuries. The fact that Yamamoto on more than one occasion chose women as models for his menswear fashion shows was another small piece of his sexual identity puzzle.

Even when his later work embraced the sweeping romanticism of postwar Parisian haute couture, Yamamoto's historical recontextualizations contrasted sharply with the work of other marquee designers. Deliberately absent from his runway presentations were the requisites of the contemporary high-fashion wardrobe for women: high heels, rising hemlines, plunging necklines, and sheer fabrics. These characteristics might be the reason that Yamamoto's dark tailored suits and white shirts for both men and women have been some of his most enduring and compelling products. Worn by Western men of all classes for two centuries, the dark-colored suit and the white shirt have a combined ability to convey both sexuality and power through conformity. This blend of erotic appeal and strength was a perfect template for Yamamoto to express his postwar version of male and female sexuality.

**Basic black.** No color in the fashion palette has been as important in the work of Yohji Yamamoto as black. This early unrelenting black-on-black aesthetic earned his devotees the nickname *karasuzoku*, or members of the crow tribe. Black has certain associations in the history of the West that have been processed through a kaleidoscope of self-conscious modernist or postmodernist theories and assumptions. As a result of historical recontextualization, black had by the last quarter of the twentieth century acquired a range of meanings, such as poverty and devastation for some fashion critics, and sobriety, intellectualism, chic, self-restraint, and nobility in dress for others.

The aesthetic attributes of traditional Japan and contemporary culture, as well as the role black plays in fashion, can be seen in the color's association with poverty. For some observers, black is an illusion of—or perhaps an allusion to—rusticity, simplicity, and self-restraint. In Japan, black dyes may connote rural origin as well as noble warrior status. An important connection between black and the symbolic associations of old Europe, traditional Japan, and the modern urban landscape may also be derived from the couture atelier. Yamamoto, like

Cristóbal Balenciaga, often created day suits, dresses, ball gowns, and coats devoid of any ornament. Charcoal gray, navy blue, and of course black woollens were often molded and manipulated into pure sculptural forms that displayed both marvelous engineering and tailoring techniques as well as a love of dramatic form.

**Deconstructed styles.** The connection between deconstruction, originally a French philosophical movement, and contemporary fashion design has yet to be fully explored by fashion historians. There is no direct evidence that such ideas were the motivating force in the early designs of Yohji Yamamoto. It is more likely that he combined a *mélange* of influences: the devastation and rapid rebuilding of Japan in the postwar era; the revolt against bourgeois tastes; an affiliation with European street styles; and a desire, like that of the early proponents of abstraction in fine art, to find a universal expression of design by erasing elements that assign people to specific socioeconomic and gender roles.

Aesthetically, the dressmaking techniques that gave Yamamoto's work its deconstructed look were also related to traditional non-Western methods of clothing construction as well as to the concept that natural, organic, and imperfect objects can also be beautiful. Yamamoto's clothes masked the body with voluminous folds and layers of dark fabric; in addition, they diminished such evident elements of clothing as frontality and clear demarcations between the inside and outside of a garment.

Yamamoto's version of deconstruction fashion more likely began by questioning the very essence of his postwar existence. Japan's initial efforts to rebuild its physical and political infrastructure, and its later economic ascendancy, did provide the right environment to foster the talents of an amazingly creative generation that included the architects Tadao Ando, Arata Isozaki, and Kenzo Tange as well as the furniture designer Shiro Kuramata and the fashion designers Yamamoto and Kawakubo.

It seems more plausible that Yamamoto was fueled by the anger typical of the generation that spearheaded the social changes of the 1960s. Thus he arrived at a new vision for fashion that railed against the bourgeois conformity that resulted from what Yamamoto obliquely referred to as American colonialism. Though the exact elements that led him to the creation of his particular style may not be known, more than one journalist concluded that Yamamoto's clothing reflected a kind of anger that evoked images of nuclear holocaust survivors and were labeled the "Hiroshima bag lady" look by some. A few critics even made an alliance between his fashions and a coven of witches.

Despite such misunderstandings, the designs of Yamamoto paralleled the rise of punk fashions and street style, and their connection with mid-twentieth-century urban degradation. In fact, more than one writer noted that the look established by Yamamoto was neither a pure invention on his part nor a derivative of Asian culture.



Such London-based designers as Malcolm McLaren and Vivienne Westwood, like other disenfranchised English youth, turned clothing into a medium for political expression and were at the forefront of the punk movement.

Yamamoto's ability to see beauty in degradation, however, and to strip things to their foundation in a search for the inherent integrity of each object is profoundly Japanese. This aesthetic of imperfection, incompleteness, or poverty, is a hallmark of *wabi-sabi*. A worldview that originated in Zen Buddhism, *wabi-sabi* was later applied to the creation of objects characterized by external lack of ornamentation and internal refinement (*wabi*) and an emphasis on the ephemeral nature of all things that eventually leads to decay (*sabi*). While Yamamoto did not formally study *wabi-sabi*, he is the product of his culture, one that is arguably the most aesthetically refined in the world.

### Mature Work

The initial impact of Yamamoto's designs began to diminish as the 1980s came to a close; the designer fell into a self-professed decline for the next few years. By the mid-1990s, however, Yamamoto experienced a resurgence of creativity rare in contemporary fashion. His output was vastly different from his work of a decade earlier, in that it fully embraced the most lyrical and fleeting elements of historical modes. His designs became a blend of street-style realism and Victorian romanticism, reshaped and reconfigured for a contemporary audience. At both extremes, Yamamoto retained his very personal vision—creating clothes for an ideal woman who, according to the couturier, does not exist.

Perhaps the most potent quality that Yamamoto displayed was his brilliant ability to recontextualize the familiar into wearable creations that came as close to works of art as any clothing designed in the early 2000s. Although he created several lines of clothing for both men and women, it was his couture-inspired creations for women that manifested this concept most completely. One of the best fashion presentations in recent memory was the spring 1999 collection that Yamamoto created around the theme of a wedding. All the Yamamoto hallmarks were evident: the play on androgyny as seen through an array of masculine-tailored suits; the reliance on a neutral color scheme of black, white and khaki; and magnificent three-dimensional gowns that evoked both the Victorian era and the golden age of twentieth-century Parisian haute couture. The glory of the garments was further enhanced by the lyrical presentation itself, with the highlight being a young bride who performed a reverse striptease. Rather than disrobing, as is usually the case in fashion shows, the mannequin, dressed in an unadorned hoop-skirted wedding gown, pulled her mantle, a pair of sandals, a hat, gloves, and finally, a bouquet of flowers from pockets hidden in the gown. Fittingly, the usually jaded fashion journalists found themselves shedding tears before giving Yamamoto a standing ovation.

After the success of this collection, he was honored as international designer of the year by the Council of Fashion Designers of America in New York City in June 2000.

Yamamoto continued to evolve in the early 2000s. His spring 2003 collection was not shown during the Paris ready-to-wear fashion week in October of 2002, but instead during the haute couture presentations earlier that year. Simultaneously, he became the designer for a new line of clothing produced in conjunction with the Adidas sportswear company called Y's 3. This agreement came about after Yamamoto first designed an astoundingly successful set of trainers, athletic shoes, and sports shoes for Adidas in 2001.

See also **Benjamin, Walter; Fashion, Theories of; Film and Fashion; Japanese Fashion; Punk; Street Style; Westwood, Vivienne.**

### BIBLIOGRAPHY

- Armstrong, Lisa. "Deconstructing Yohji." *British Vogue* (August 1998): 134–137.
- Chua, Lawrence. "Exploring the Yamamoto Cult." *Women's Wear Daily* (April 1988).
- Hildreth, Jean C. *A New Wave in Fashion: Three Japanese Designers, March 1–April 24, 1983*. Phoenix, Ariz.: The Arizona Costume Institute of the Phoenix Art Museum, 1983.
- Hirokawa, Taishi. *Sonomama Sonomama: High Fashion in the Japanese Countryside*. San Francisco: Chronicle Books, 1988.
- Kondo, Dorinne. *About Face: Performing Race in Fashion and Theater*. New York: Routledge, 1997.
- Koren, Leonard. *New Fashion Japan*. Tokyo: Kodansha International, 1984.
- Martindale, Richard. "Destitution and Deconstruction: The Riches of Poverty in the Fashions of the 1990s." *Textile and Text* 15 (1992): 3–12.
- Takashina, Shuji. "Japonism: An Aesthetic of Shadow and Fragment." In *Japonism in Fashion*. Edited by A. Fukai. Tokyo: Kyoto Costume Research Foundation, 1996.
- Wenders, Wim. *Aufzeichnungen zu Kleidern und Städten (Notebook on Cities and Clothes)*. Berlin: Road Movies Filmproduktion in cooperation with Centre National d'Art et du Culture Georges Pompidou, 1989.

Patricia Mears

**YARNS** Yarns are linear structures that are formed by collecting and twisting fibers together. Converting fibers into yarns is a necessary step for weaving or knitting fabrics. Yarns can be classified in a number of ways: by type, size, number of parts, or similarity of parts. These classifications determine the specification of yarns for end-use textile products with different properties. Yarn structure can affect fabric strength, appearance, comfort, feel or hand, and drape among other properties.

The two main types of yarns are staple and filament. Staple yarns, also called spun yarns, are made of fibers

that come in short discrete lengths. All natural fibers except silk are staple fibers. Filament yarns are collections of long continuous filament fibers. Silk is such a fiber, and manufactured fibers are produced in filament form. The manufactured filaments can then be cut into staple lengths if staple yarns are desired.

### Staple Yarns

Staple fibers are formed into yarns by a series of processing steps that have been developed over time for specific fibers. Cotton, wool, and linen yarns all have their distinctive processes. The cotton system is the most commonly used, for both cotton and cotton-blend yarns.

In the cotton system, fibers from bales are first run through rollers with spikes to pull the clumps apart, and are then further separated in an opening and cleaning step where trash is removed. This is followed by carding, in which the fibers are passed through fine wires or pins to individually separate and align them. They emerge as a loose collection of aligned fibers known as a sliver. The sliver can then be combed, an optional step in which the carded fibers are pulled through fine combs to remove shorter fibers and arrange the longer fibers into a parallel form. Cotton fabrics made from these yarns are smooth and soft and often labeled “fine combed cotton.” As can be imagined, combed cottons are more expensive than yarns that are carded only. After several processes in which the carded or carded and combed fibers are drawn through rollers, they are slightly twisted to form a soft rope called a roving. The roving is tightly twisted in the final spinning step.

Preparation of wool fibers for spinning is similar. Fibers that are carded only are formed into woolen yarns, which are soft and bulky. Worsted yarns, on the other hand, are combed and also subjected to a special drawing process, gilling, where pins help to straighten the fibers. Worsted yarns are more tightly twisted in the final spinning step, making them smoother and more compact in appearance.

There are several techniques for inserting the final twist in staple yarns. Ring spinning is the most mature spinning method. The yarn is wound on a bobbin or spool that rotates at a high rate of speed. The rotation twists the loose rope of fibers into a strong yarn. Ring spinning gets its name from a ring that travels up and down the spindle. A small clip, the traveler, holds the yarn and moves around the ring. Ring-spun yarns are smoother and stronger than yarns made by other spinning techniques, and can also be made in finer sizes. Ring spinning is slower and therefore more expensive than other methods, prompting garment makers to identify ring-spun yarns in products such as cotton underwear and T-shirts.

Another process for twisting staple yarns is open-end spinning. In its most common manifestation, rotor spinning, the fiber roving is carried by an air stream into a rapidly spinning rotor with a V-shaped groove. The fibers

are deposited by centrifugal force in the groove and then drawn off through a center delivery tube. The operation bears some resemblance to a cotton candy machine. As the fine candy fibers are formed they are caught and collected. In rotor spinning, fibers are caught by the “open end” of a previously formed yarn and the rapid rotation of the rotor twists the yarn. Rotor spun yarns are more uniform than ring-spun yarns, but not as strong. In addition, they cannot be made in very fine sizes. Most cotton yarns for denim are rotor spun.

Friction spinning is another open-end method. A mixture of air and fibers is fed between two drums rotating in opposite directions. This inserts twist into the fibers, much as spinners did in ancient times by rolling clumps of fibers between their fingers.

An increasingly popular spinning method is air-jet spinning. Yarns are formed by jets of air forcing the outer layers of fibers in a sliver to wrap around the interior fibers. Air-jet yarns are weaker than ring or open-end spun yarns, but can be made in finer sizes.

### Filament Yarns

Filament yarns are made by gathering together long continuous fibers, with or without inserting twist. Filament yarns produce fabrics that are smooth and slippery to the touch. They are also stronger than staple yarns, which is why before the discovery of synthetic manufactured fibers parachutes were made of silk. Because of their value, the parachutes used during World War II were often retrieved by civilians and made into garments. Filament yarns are also associated with luxury fabrics such as satin and velvet, which were traditionally made with silk filament yarns.

To change their properties, filament yarns can be textured or “bulked.” This makes them softer, stretchier, more resilient, and more like staple yarns. Textured yarn fabrics are also more permeable to moisture and air, increasing the comfort to the wearer. Common texturing methods are: false twist, in which the yarns are twisted, heated to set the twist, and then untwisted; and air jet, in which the slack filaments in the yarn are entangled and formed into loops by jets of air. False twist imparts stretch as well as the look and feel of staple yarn fabrics. Air jet yarns are soft and bulky but have little stretch. The polyester double-knit fabrics of the 1960s were made of textured filament yarns.

### Yarn Size

Over the years different systems have emerged for designating the size of textile yarns. The oldest systems are “indirect,” in that the higher the number is the smaller, or finer, the yarn. Cotton count is an indirect system for specifying the size of cotton and cotton-blend yarns. It is the number of 840-yard lengths of yarn in one pound. As spinning processes were developed for wool and linen, specific yarn numbering systems were created for these



**Yarn dyeing.** A worker lowers four spoils of yarn into a dyeing vat with a remote control. Textile styles such as bouclé and tweed can be produced by blending different color yarns. © ROGER BALL/CORBIS. REPRODUCED BY PERMISSION.



fibers, differing in the lengths that are specified per pound of yarn.

These indirect systems for yarn size were based on English measuring units (yards, pounds); the move toward universally accepted metric units has resulted in yarn numbering systems in which the yarn count varies directly with the size. Tex is the weight in grams of 1,000 meters of yarn, while denier is the weight in grams of 9,000 meters. Tex is the more general term as it can be used for sizing both staple and filament yarns.

An understanding of the relative sizes of yarns can be used to determine appropriate end-uses for fabrics. Properties such as strength, smoothness, drape, and wrinkle resistance are affected by yarn size. For example, heavier yarns are used in denim fabrics for jeans and pants because both strength and some degree of wrinkle resistance are desired. Cotton blouses and shirts, however, would require smaller yarns for a smooth comfortable feel.

### Number and Similarity of Parts

Yarns can be single, ply, or cord. Single yarns are made from staple or filament fibers twisted together. Ply yarns are two single yarns twisted together. They are stronger and smoother than singles. Most sewing threads are ply yarns. The strength and smoothness help the threads withstand the friction and mechanical action during sewing. Twisting two or more ply yarns together forms cord yarns, which are stronger still. Cords are mostly destined for industrial uses such as cables and ropes, although they can be used in apparel for different effects and textures.

If all parts of a yarn, be it single, ply, or cord, are uniform in size and have a regular surface, the yarn is termed a simple yarn. Varying the structure of one or more of the parts of a yarn produces a novelty yarn. An example of a novelty single yarn is a crepe yarn, which is over twisted to yield kinks and an irregular surface.

A great variety of novelty yarns can be made by plying two dissimilar singles or twisting similar singles in an irregular structure. In a bouclé yarn, one ply (the effect yarn) forms irregular loops around the base yarn. Ratiné yarns are similar in structure, but the loops are regularly spaced along the yarn. The loops are visible in fabrics made with bouclé or ratiné yarns. Another variation of this is twisting the effect yarn irregularly around the base yarn so that it creates knots or nubs in some places. These are called knot, spot, or nub yarns. Varying the degree of twist along single or ply yarn produces thick soft "slubs" in the yarn. Slub yarns show these irregularities in the fabric; one such fabric is shantung, often made of silk. Spiral or corkscrew yarns are made of two plies, one of which is heavy and soft, winding around a finer core yarn.

Chenille yarns are different from other structures in that a fabric is first woven, then cut into strips that form the yarn. The strips have fiber ends sticking out on all sides and the yarn resembles a caterpillar. These fluffy ends protrude in fabrics containing chenille yarns.

Color can be used to produce or enhance novelty effects. In plied yarns for example, single yarns of different colors can be twisted together. This effect is enhanced in bouclé, ratiné, or corkscrew yarns. Tweed fabrics are made from novelty single yarns; the novelty lies in combining different colored fibers in a single spun yarn.

### Blended Yarns

Blended yarns, which contain mixtures of fibers, have several purposes. Self-blending is done to more thoroughly mix fibers, particularly natural fibers, from different sources. This minimizes the possibility of concentrating fiber defects in one section or batch of yarn. Another purpose of blending is to combine the properties of different fibers, for example the comfort and absorbency of cotton with the strength and wrinkle resistance of polyester. Cotton-polyester blends are popular fabrics and are usually made by mixing the fibers at some stage of processing.

Fibers can be blended when bales or boxes are opened and cleaned prior to carding. They can also be mixed by drawing several slivers together. Repeated drawing of blended slivers enhances the mixing. Yarns for Harris tweed fabrics are made by blending different colored wool fibers in large chambers supplied with air streams, prior to carding.

*See also* **Spinning; Spinning Machinery; Wool.**

### BIBLIOGRAPHY

- Demir, Ali, and Hassan Mohamed Behery. *Synthetic Filament Yarn*. Upper Saddle River, N.J.: Prentice Hall, 1997.
- Goswami, Bhuvnesh Chandra, J. G. Martindale, and F. L. Scardino. *Textile Yarns: Technology, Structure, and Applications*. New York: Wiley-Interscience, 1977.

*Billie J. Collier*

**YEOHLEE** A native of Malaysia, Yeohlee Teng (1955–) came to the United States to study at the Parsons School of Design in New York City. She worked in New York since her graduation from Parsons, and opened her own house, Yeohlee Inc., in 1981.

Yeohlee's strong and consistent approach to clothing design has made her name synonymous with efficiency, striking geometrical designs, and concise functionalism. All of her clothing patterns have incorporated the principle of maximum utilization of fabric. Her signature garment was a one-size-fits-all hooded cape cut from a single 3.25-yard piece of 60-inch fabric, using all of the material with no waste whatsoever. This unique cape brought her widespread attention when it was included in her first collection in 1981, and it has been in every one of her collections since then. Yeohlee also pioneered the use of high-tech fabrics and surface treatments to produce wrinkle- and stain-resistant clothes that are easy to care for and easy to pack. She worked with a

palette of colors that emphasized black, white, and earth tones, though her collections were also often accented with striking shades of green, red, and orange. Yeohlee designed for the urban nomad, a postmodern customer who demanded adaptable, functional, low-maintenance clothing that looked appropriate and made a powerful impression in a wide range of situations. The designer was associated with the phrases “clothing as shelter” and “intimate architecture.”

The output of Yeohlee Inc. was aimed at a relatively small and loyal customer base rather than at the mass market; the company sold through a limited number of department stores and specialty shops in the early 2000s. Yeohlee’s designs tended to be relatively uninfluenced by seasonal and annual fashion trends, but rather followed the evolution of her own design vision. Her clothes appealed to the sophisticated, design-conscious clientele of the early 2000s.

Yeohlee’s work, often described as “architectural,” attracted the attention of critics and professionals in other fields of design. To an extent unusual for fashion designers, her clothes were exhibited as design art in many museums and galleries in the 1990s and early 2000s. Her participation in the group show *Intimate Architecture: Contemporary Clothing Design*, presented at the Hayden Gallery at the Massachusetts Institute of Technology in 1982, won a great deal of favorable attention for her work and was an important factor in the early success of her company. Her clothes were also featured in solo shows at the Aedes East Gallery, Berlin; P.S. 1, New York City; the Netherlands Architecture Institute, Rotterdam; the London College of Fashion in association with the Victoria and Albert Museum, London; and the Museum at the Fashion Institute of Technology, New York, as well as in a number of other group shows. Her work was also placed in the permanent collections of the Costume Institute of the Metropolitan Museum of Art, the Museum at the Fashion Institute of Technology, and other major fashion museums worldwide.

In the words of the late fashion historian Richard Harrison Martin, Yeohlee “is one of the few practitioners of her art who has fully eschewed fashion hyperbole to engage in a critical discourse about clothing in space [and] on the body.”

See also **Fashion Museums and Collections; High-Tech Fashion; Performance Finishes; Techno-Textiles.**

#### BIBLIOGRAPHY

- Major, John S., and Yeohlee Teng, eds. *Yeohlee: Work—Material Architecture*. Mulgrave (Victoria), Australia: Peleus Press, 2003.
- Steele, Valerie, and John S. Major. *China Chic: East Meets West*. New Haven, Conn., and London: Yale University Press, 1999.

*John S. Major*

**YOUTHQUAKE FASHIONS** A tag, a slogan, and a rallying cry, “Youthquake” exemplifies the slickness as well as the conviction, the spontaneous ebullience as well as the commercial aggression that during the 1960s marked the triumph of London ready-to-wear. Powered by the momentum of a cresting youth culture, a cadre of British designers, mostly women, wrenched dominance away from the Paris couture houses and profoundly altered global fashion.

Youthquake fashion cannot be explored or understood without acknowledging its social and political context. In *Fifty Years of Fashion*, Valerie Steele notes that the “narrow, apolitical approach,” preferred by many fashion journalists “becomes insupportable when dealing with the 1960s” (p. 49). These clothes garbed armies of protagonists in the ongoing narrative of women’s economic, sexual, and social independence, and the consequent and reciprocal expansion of men’s personas. In 1988, Mary Quant recalled: “Women had been building to this for a long time, but before the pill there couldn’t be a true emancipation. It’s very clear in the look, in the exuberance of the time—a rather child-like exuberance. “Wow—look at me!—isn’t it lovely? At last, at last!” (Conversation with author, December, 1988).

Youthquake fashion was also a lever as well as a product of the increased social mobility engendered by the postwar Labor governments of Britain. Due to government-subsidized tuition, an unprecedented number of students of humble origin were now able to pursue careers in the fine and commercial arts. At the Royal College of Art, Madge Garland, formerly editor in chief of British *Vogue*, had developed a graduate program in fashion design. Professor Janey Ironside became the program’s principal in 1956. “We were trained to see, to explore, to enjoy ourselves,” recalled RCA alumna Sally Tuffin, one half of celebrated Youthquake design team (Marion) Foale and Tuffin. “We felt as though we could go off and do anything, without restriction.” (Conversation with author, November, 1988).

#### Boutiques

Throughout the 1950s, British fashion was dominated by the Paris couture, and the long shadow it cast over London couturiers such as Norman Hartnell and Hardy Amies. British manufacturers followed the parameters laid out by the high end of fashion. But the emerging generation wanted something entirely different and entirely their own. They were out of sympathy with the mores of expensive made-to-order clothing. “The couture was for kept women,” said Barbara Hulanicki, who opened the London boutique Biba after working as a fashion illustrator in the late 1950s and early ’60s. As she sketched the couture for London newspapers, Hulanicki objected as well to “the snobbery that was designed to make everyone feel inferior.” (Conversation with author, November, 1988)



**Audrey Hepburn wears a Courrèges hat, 1965.** Youthquake designers pushed forward the mod look, which favored monochrome and streamlined outfits. © DOUGLAS KIRKLAND/CORBIS. REPRODUCED BY PERMISSION.

Youthquake fashion found its own staging ground as the boutique replaced the couture salon as fashion incubator. The Youthquake boutique was somewhere between a neighborhood dressmaker's atelier and the auxiliary shops maintained within some Paris couture strongholds, in which accessories and related bagatelles might be sold. Youthquake fashion could be said to have begun in November 1955, when Quant, recently graduated from art college, opened her boutique "Bazaar" in the London district of Chelsea. A year later she started designing because she couldn't find the type of clothes she wanted to stock her store.

"What was wrong at that stage was that fashion only came through one route," Quant recalled, "which designed for a way of life which was very much that of a minority."...She instead would design for "women who had a job and a fantasy life that took that job into account" (conversation with author, December 1988). The daughter of schoolteachers, Quant was married to Alexander Plunkett Greene, scion of an aristocratic lineage. Their marriage became emblematic of falling class barriers.

### The Miniskirt Emerges

Chelsea had long been a magnet for London artists and bohemians, and during the 1950s it was a haunt for the city's Beatnik culture. Quant paid tribute to their mini-

mal and monochromatic uniforms. As the couture never could, Quant and her brethren acknowledged, even asserted defiantly, that a primary design inspiration was the clothes of the young wandering the streets outside their workrooms. Quant was enamored, too, of the look of tap dancing students she'd watched as a child, as they practiced wearing short skirts, black tights, and patent-leather shoes. She kept on raising hemlines, and eventually Quant became known as "Mother of the Miniskirt." Some accounts have her showing skirts above the knee by 1958, although Quant's claims to precedence were challenged by Paris couturier André Courrèges. But who was first, or if there indeed was a first, is of peripheral importance. As far back as the late 1920s, hemlines were almost above the knee, and it was inevitable that after the long skirts of the late 1940s, they would rise again. As well, the inexorable shifts in society provided an historical imperative. In 1968, British fashion historian James Laver described the miniskirt as "the final word in the emancipation of women—in proving her economic independence...Long, hampering skirts were fetters to keep a woman at home. The very short ones scream: 'I am stepping out'" (*WWD* March 22, 1968, p.8).

### King's Road

Eventually, there were three Bazaars in London. They survived until 1968, by which time Quant was presiding over a vast wholesale and licensing empire. Bazaar was a catalyst in King's Road's transformation into a streaming, coursing artery of fashion and display. Kiki Byrne, who had worked as Quant's assistant, also opened a celebrated boutique there, where Hulanicki was enthralled by Byrne's "wonderful black dresses ... shifts that weren't over-designed" (conversation with author, November 1988). Her generation wanted something much looser both philosophically and structurally even than the unfitted shape that was being shown in the Paris couture as the 1950s progressed. The Youthquake silhouette was less determined, less sculptural, less constructed, and usually less decorated. "Our clothes *had* to be comfortable," Tuffin recalled. "That was the main requirement" (conversation with author, November 1988).

While the Paris couture continued to take itself very seriously, the kingdom of Youthquake teemed with humor and irreverence. Quant gave droll names to her clothes and arranged gag tableau in her store windows. Foale and Tuffin put Y's across the front of shift dresses—"Y-fronts" were men's underwear briefs.

Where pants for women were concerned, London was more adventurous than the Paris couture or even the "ye-yes," the young ready to wear designers of Paris. The Foale and Tuffin trouser suit became a global prototype—"The cut was incredible," Betsey Johnson recalled, "the best I've ever seen" (conversation with author, August, 1987). They were strongly advocating trousers well before Courrèges's pants-dominated couture collections of the mid-1960s. Yet in 1961, when they first began



teaming pants instead of skirts with jackets, the combination seemed so incongruous that “we actually fell about laughing,” Tuffin recalled. Lines were straight, shoulders natural, the jacket semi-fitted like riding attire, but devoid of constructed reinforcement. The trouser suit was one of Youthquake fashion’s most controversial provocations, but also one of its most enduring legacies.

Youthquake fashion at its most egalitarian and inclusive was represented by London’s Biba boutique, which Hulanicki opened with her husband Stephen Fitz-Simon in 1964. “We practically gave our things away to the public,” Hulanicki claimed. Biba practiced a rapid response to the trends of the street, alternately spurring and parrying the restless experimentation of the young. “I couldn’t stand wholesale,” Hulanicki said, “because it’s just between you and the buyer, and the buyers are always wrong, anyway. They want what sold last year, but we were working right on the moment, all the time” (conversation with author, November 1988). Biba kept moving to larger and large quarters, its decor an iconoclastic *mise-en-scène* of oddments and antiques. With Biba, the Youthquake boutique reached its apogee as destination, event, parade ground, and crossroads.

Although at Biba the use of inexpensive synthetics was dictated by the need to keep prices down, synthetics were also championed by Youthquake fashion for reasons other than necessity. Rather than simply a pallid imitation of natural fibers, they could manifest novel textures and appearances. Machine-tooled fabrics were celebrated as a threshold to a utopia of increased leisure and lessened drudgery. Quant extolled their ability to look “like a delicious soufflé that happened with a pure kind of joy—without anybody’s tears on them” (conversation with author, December 1988).

Youthquake designers were certainly gratified by the boggled attention their work received by mainstream manufacturers, journalists, and even the *couture* itself. But they were primarily concerned with designing for themselves and their contemporaries, and because of the exploding youth market, were able to do so without compromise. Certainly mature women could legitimately complain that the ubiquitous narrow armholes of the Youthquake silhouette were not easy to fit into. Women who’d been brought up on the postwar British rations were not robust. Hulanicki noted that the average women’s shoe size during the 1960s was 3 1/2 or 4, while twenty years later it had jumped two sizes. The somewhat androgynous silhouette privileged by Youthquake fashion was also an aesthetic and sexual statement, however, a rejection of the overblown ideal of hourglass femininity that been promulgated during the 1950s by the *couture* and, perhaps more oppressively, by the imagery of popular culture.

### Men’s New Look

Women’s reassessment of gender-specific clothes and behavior, unleashed from men a rejection of the dour



**Mary Quant with model wearing miniskirt.** Quant became known “the Mother of the Miniskirt,” a garment that became very popular with young women in the late 1960s. © Bettmann/Corbis. Reproduced by permission.

clothes that had been obligatory since the Regency epoch of the nineteenth century. Young working-class men of the late 1950s organized themselves into coterie—the Teddy Boys, The Mods, the Rockers—each with its own odd and distinctive uniform. Around this time, Scottish-born retailer John Stephens began to transform London’s Carnaby Street into a chockablock concentration of stores inviting men to cast off the fetters of old. Once all but completely polarized, men’s and women’s clothes could now converge into unisex outfits designed to be worn by either sex. A colony of men’s and unisex boutiques sprung up around London, allowing men a selection unlike anything previously imaginable.

### Clothing Anarchy

Biba’s enveloping of new world fashions in the warm patina of vintage furnishings could be seen to anticipate the historical bent of late ’60s London fashion. The city’s archival closets were turned inside out and its streets became a fantastic masquerade. The rage for antique clothing, as well as the folklore and psychedelic panoply of the

hippies dominated this second phase of Youthquake. The hippies' sartorial revolution evolved from the fashions of the Beats and the British ready-to-wear sisterhood; its founding mothers smoothly negotiated this second phase of Youthquake. The late '60s also saw the rise of designers like Ossie Clark and Zandra Rhodes, whose gossamer and fanciful creations recalled the romanticism of Arts and Crafts dress of the previous century. Vanguard London fashion of the late '60s was more anarchic than earlier in the decade. The *laissez-faire* of the hippies necessitated less homogeneous internal consistency to broadcast its sartorial and cultural message.

### The End of an Era

By the mid-1970s, however, the very moniker Youthquake was superannuated. Many of the movers and shakers were in states of decompression or stately retreat. Quant was by now concentrating entirely on licensing. Foale and Tuffin disbanded. After Hulanicki and Fitz-Simon's alliance with outside capital, Biba suffered a bitter demise not long after reaching its apotheosis taking over a huge Art Deco department store. On the other hand, designers like Rhodes thrived amid a London fashion environment that continued to appreciate the eccentric. Conversely, the more muted and classic designs of Youthquake's Jean Muir became more popular than ever.

The plucky young firebrands of Youthquake had succeeded in radically upending global fashion markets. London itself has never returned to the fashion backwaters it was in the 1950s. The social and economic leveling proclaimed by Youthquake's habits and habiliments were not defeated by reactionary political developments during Britain in the 1980s. The Youthquake movement will always be an inspiration to those who seek to democratize fashion and tap the creative vitality of youth.

See also **Biba; Miniskirt; Quant, Mary.**

### BIBLIOGRAPHY

- Lobenthal, Joel. *Radical Rags: Fashions of the Sixties*. New York: Abbeville Press, 1990.
- Mulvagh, Jane. *Vogue History of 20th Century Fashion*. London: Viking, 1988.
- Quant, Mary. *Quant by Quant*. London: Cassell, 1966.
- Steele, Valerie. *Fifty Years of Fashion: New Look to Now*. New Haven, Conn.: Yale University Press, 1997.

Joel Lobenthal

**YUKATA** The *yukata* of the early 2000s has remained, since the Edo period (1603–1868), an unlined cotton garment, with the traditional T-shape and overlapping lapels of the kimono. Purists may consider it more of a bathrobe than a true kimono. An ancestor of the modern yukata is the *katabira*, an unlined bast fiber (usually hemp or ramie) *kosode* worn in the summer by the upper classes. A *yukatabira* (*yu* is derived from the word for bathing) was



**A Japanese woman wearing a floral yukata.** Made of lightweight cotton, *yukata* are kimonos usually worn in the summer. © ROBERT ESSEL NYC/CORBIS. REPRODUCED BY PERMISSION.

put on after a bath as a way of drying the body; bath towels were not used in Japan at this time.

By the late Edo period cotton was abundant in Japan, having first been successfully cultivated as a commercial crop in the seventeenth century. As cotton, while still a bast fiber, is a softer and more absorbent fiber than hemp or ramie, it became the fiber of preference for the yukatabira. By the time cotton was readily available, the garment became known by its current abbreviated name, yukata.

Cotton is more easily dyed than other bast fibers, and indigo is one of the most colorfast of all natural dyes. It has the additional benefit of not requiring a separate mordanting process. Blue, therefore, became the dominant color for cotton yukata, and remains so, in spite of the prevalence of the more practical and versatile synthetic dyes, which can create virtually any desired color on cotton. Blue remains as popular a color for yukata as it was during the Edo period, when the color brought to mind coolness and water, welcoming thoughts during the hot Japanese summers.

The most common method employed for the dyeing of cotton fabric intended for yukata involved the use of paper stencils and a resist-paste made from rice. Stencils slightly wider than the width of a single bolt of cloth were cut with intricate designs, both figural and abstract. Rice paste was applied through the stencils, and the bolt of cloth would then be dyed by immersion in the indigo vat. The indigo dye would not penetrate the cloth in areas where the rice paste adhered; therefore, the designs would appear in white and the background in blue.

The custom of soaking in a wooden tub filled with hot water is relatively recent in Japanese history. Prior to the eighteenth century, bathing consisted of taking a steam bath. The rise of the public bathhouse (there were more than 500 in Edo [modern-day Tokyo] by the mid-nineteenth century) created a milieu for the wearing of yukata in a public place on a regular basis. Bathhouses were popular not only for reasons of hygiene and relaxation, but also because they often included rooms for eating, drinking, and having sex.

The most enthusiastic customers of the bathhouses came from the lowly merchant class, and they welcomed the opportunity to make a show of the latest in yukata designs. As with kosode, it was kabuki actors and other entertainers who often launched new fashions in yukata. Witty and amusing larger-scale motifs were most popular, and required the use of the *chûgata* stencil, as opposed to the tiny-scale repeats of the komon stencil. Komon patterns were typical of the dignified and conservative samurai class.

Another reason for the popularity of the yukata as a fashionable garment was the existence of sumptuary laws, which impacted most strongly on the merchant class. A yukata, being made of cotton rather than silk, and patterned by the inexpensive process of stencil dyeing, might be excessive in design, but was never very costly. Therefore, yukata escaped the scrutiny of the government authorities.

As Japan modernized in the Meiji period (1868–1912) and beyond, yukata became the one traditional garment that a man might wear in public. Hot spring resorts were, and still are, another popular venue for the yukata, as are traditional summer festivals, such as Obon. Foreign visitors to Japan, especially those who stay at a traditional inn (*ryōkan*), will find a yukata in their room, which conveniently presents the foreigner with an opportunity to wear a kimono-like garment.

See also **Japanese Fashion; Japanese Traditional Dress and Adornment; Japonisme; Kimono.**

#### BIBLIOGRAPHY

- Gonick, Gloria Granz. *Matsuri! Japanese Festival Arts*. Los Angeles: UCLA Fowler Museum of Cultural History, 2002.
- Kuo, Susanna Campbell. *Carved Paper: The Art of the Japanese Stencil*. Santa Barbara, New York, and Tokyo: Santa Barbara Museum of Art and Weatherhill, Inc., 1998.
- Stevens, Rebecca T., and Yoshiko Iwamoto Wada, eds. *The Kimono Inspiration: Art and Art-to-Wear in America*. Washington, D.C.: The Textile Museum, 1996.

*Alan Kennedy*





**ZIPPER** More generically called a “slide fastener,” the zipper is used as a closure in garments and a variety of other articles. Zippers were first introduced in a primitive form in the 1890s, but were not widely accepted in clothing until the 1930s.

The fastener that Americans most commonly call “zippers” can be traced to the invention of a Midwestern traveling salesman, Whitcomb Judson, in the early 1890s. Judson patented his device as a “clasp locker or unlocker” for shoes; this invention resembled the later zipper only superficially. It consisted of a series of hooks and eyes, each pair of which was engaged by the action of a key or slider. Over the next few years, Judson designed modifications of this device, none of which worked very effectively. The idea of an “automatic hook-and-eye,” however, caught the attention of entrepreneurs, so Judson was given money and encouragement to continue engineering his invention, and in the first years after 1900, the first devices came to market under the aegis of the Universal Fastener Company of Hoboken, New Jersey.

After several years of futile design and sales efforts, the Hoboken company gained the services of a Swedish immigrant, Gideon Sundback. Trained as an electrical engineer, Sundback was a remarkably clever and astute mechanic. He analyzed with care the key elements of the automatic hook-and-eye, and concluded that the hook-and-eye model was not a suitable one for any kind of automatic fastener. Late in 1913, Sundback introduced his “Hookless Fastener,” based on novel principles and resembling in all important respects the modern metal zipper.

Sundback’s hookless fastener depended on the action of a series of closely spaced elements, technically called “scoops,” whose precise spacing and ingenious shape are key to the fastener’s success. Each scoop has a dimple on one side and a protruding nib on the other. The fastener consists of two opposing rows of scoops, spaced so that the scoops from one side engage in the spaces between the scoops on the other side. The nib from one scoop fits into the dimple in the facing scoop, whose nib in turn fits into the next dimple down the row. Sundback likened the action to a series of spoons in which the bowls of alternating spoons fitted into one another. If the spoons at each end of the rows are held in place, the intermediate

spoons cannot disengage one another. The slider’s function is simply to bring the two rows of scoops together (or to separate them) in a continuous, serial action.

The entrepreneurs who had backed Judson and then Sundback readily saw the efficacy of the hookless fastener design. Sundback’s contributions went further to include the construction of machinery that made fastener manufacture rapid and economical. The Hookless Fastener Company was organized in Meadville, Pennsylvania, and efforts to market the novel device began in 1914. The fastener makers encountered challenges every bit as formidable as the technical ones they had overcome after such effort. The early hookless fastener was an unquestionably clever device, and it worked reasonably reliably and consistently. It was, however, expensive compared to the buttons or hooks and eyes that it was designed to replace, and it posed a host of difficulties for the designers and makers of most garments.

The clothing industry initially rejected the new fastener. It might, in fact, have died an ignominious early death if its salesmen had not cultivated small niche markets that sustained it for several years. Money belts for World War I sailors were followed by tobacco pouches, which in turn were followed, in the early 1920s, by rubber overshoes. The manufacturers of this last, the B. F. Goodrich Rubber Company, came up with a moniker for their new product, “Zippers,” that became even more popular than the overshoes themselves, and the term “zipper” came to be the common American term for the fastener (despite Goodrich’s trademark claims). Through most of the 1920s, expanding niche markets brought the fastener to a wider public, although garment makers still resisted wider adoption. Hookless Fastener adopted the trademark “Talon” in 1928 (and changed the corporate name to Talon, Inc., a decade later).

Only in the 1930s did zippers come to be accepted elements of men’s and women’s clothing, and even then only by steps. The famous haute couture designer, Elsa Schiaparelli, chose to set her designs of 1935 off by liberal use of zippers—even in places where no fastener was needed or expected. A couple of years later, in 1937, zippers began to appear widely in high fashion lines—Edward Molyneux’s pencil-slim coats, for example, used zippers to emphasize the sleek silhouette. At about the

same time, the designers of the best tailored men's clothing let it be known that zippered flies were acceptable, and by the end of the decade, zippers were common in the better men's trousers and were making their way into the ready-to-wear market. The combination of a reduction in prices (due to higher volume production) and the growing association of the zipper with modernity and fashion overcame the long-standing resistance of the garment makers and buyers. The widespread use of zippers in military uniforms during World War II was associated by many with the final popularization of the fastener, but its usage was already well on its way to becoming common before the war. By the 1950s, the zipper was the default fastener for everything from skirt plackets and trouser flies to leather motorcycle jackets and backpacks.

Even before the war, some manufacturers experimented with replacing the copper-nickel alloy standard in zippers with plastic, but this substitution was not very successful until Talon and the DuPont Company collaborated on a very new zipper design, in which the metal scoops were replaced by nylon spirals. The nylon zipper, after a few difficult years, became the standard appliance for lightweight applications, as garment makers were particularly attracted to the ease with which the nylon could be colored to match fabric dyes. Other materials were used for more specialized purposes: surgeons even adopted inert Teflon zippers for post-operative applications.

The zipper was by no means a strictly American phenomenon. Within only a few years of its introduction, British manufacturers sought to establish manufacture, and by the mid-1920s, French, German, and other suppliers followed. The chief British manufacturer, the Lightning Fastener Company of Birmingham, gave its name to the fastener itself in a wide range of languages; in France it became known as a "fermeture éclair," and in Germany as a "Blitzverschluss" (*Reissverschluss* became the more common German word later).

As the zipper became increasingly common in the twentieth century, it acquired an unusual cultural status. It became a widely recognized and used symbol with a host of associations. Aldous Huxley used zippers throughout his 1932 novel, *Brave New World*, to allude to the impersonal and mechanical nature of sex in his nightmarish world of the future. Broadway and Hollywood began in the same decade to use the zipper to convey images of promiscuity: Rodgers and Hart's 1940 musical *Pal Joey* included a famous pantomime striptease with the refrain of "zip" throughout. Rita Hayworth, in her 1946 movie *Gilda*, used the zipper more than once as an instrument of sexual provocation. Even in the realm of urban legend, the zipper quickly became a common trope, conveying the awkwardness of relying on the mechanical in the intimate realms of daily life.

In the course of the twentieth century, the zipper became so ubiquitous as to become almost invisible. It has multiplied in form, size, style, and function; ranging from

the simple plastic of the Ziploc bag to the zippers used in surgery and spacesuits. Arguably the most characteristic fastener of the twentieth century, the zipper has still not, even in the twenty-first century, lost its symbolic power to convey sexuality, opening and closing, separating and joining. And, despite the apparent allure of alternatives from old-fashioned buttons to modern Velcro, zippers appear in no danger of being displaced as the leading fastener.

See also **Fasteners; Uniforms, Military.**

#### BIBLIOGRAPHY

Friedel, Robert. *Zipper: An Exploration in Novelty*. New York: W. W. Norton, 1994.

Gray, James. *Talon, Inc.: A Romance of Achievement*. Meadville, Pa.: Talon Inc., 1963.

Robert Friedel

**ZOOT SUIT** The zoot suit cut a suave silhouette. Initially popularized by black "hipsters" in the mid- to late-1930s, but embraced more generally by swing jazz enthusiasts of all colors, the zoot suit jacket exaggerated the upper male body with wide padded shoulders and broad lapels, tapering dramatically down to the waist and flaring out to the knees. The pants were flowing, high waisted, and pleated, flaring at the knees and angling radically down to a tight fit around the ankles. The look was usually completed with a porkpie hat, long watch chain, thin belt, and matching shoes. It was a style androgynous enough to be worn by either men or women, but the fashion was most popular among men.

Eastern zooters favored eye-catching colors and patterns, but youth on the West coast preferred a more discreet appearance, possibly prompted by the March 1942 ruling of the War Production Board restricting the measurements for men's suits and rationing the availability of material for civilian use. Men's fashion in general became more moderate, and "the drape" was the more conservative version of the zoot suit. The length of the drape jacket was considerably shorter than the zoot jacket, falling at mid-thigh, and otherwise looked little different from a man's oversized business suit. Some women in Los Angeles took to wearing pleated skirts underneath the drape jacket with hosiery and huarache sandals.

Contemporary accounts placed the origins of the zoot suit in the African American communities of Gainesville, Georgia; Chicago; and Harlem, but the stylistic foundations of the zoot suit trace back to Edwardian fashion at the turn of the century. In the Northeast, the style was known as the "root suit," "suit suit," and "zoot suit"; in the South as "killer diller"; and in the West as "drape shape" or in Spanish as "el tacuche" (the wardrobe).

Jobs in war production allowed young people to experiment with consumption and a popular culture largely inspired by the African American jazz artists they admired. Jazz music, dance, clothing, and language that



**Three men wearing zoot suits at a Los Angeles night club, 1942.** Zoot suits were a trend carried by many Latino and black youth. Police and government authorities were often suspicious of the youth who wore it. © BETTMANN/CORBIS. REPRODUCED BY PERMISSION.

youth across the color line shared allowed for re-creations of social identities. For some, jazz music and the hipster style were audacious celebrations of life in spite of the difficulties blacks faced during the 1930s. For others, wearing the fashion was a show of newfound but modest wealth from wartime employment that signaled their move from square to cool or from “country” to urbane. At the same time, the zoot suit was a dashing if not scandalous image because of its association with hipsters, drugs, and sex. Such layered meanings promised rich possibilities for transforming cultural expression into a form of resistance to the social conventions of segregation.

Although a few saw the popularity of the zoot suit as a harmless development, many more had visceral reactions to it as a symbol of the breakdown of social convention. Critics of jazz fashion seemed unable to accept that working-class youth of color could afford such an expensive suit through honest means. Some saw the suit as a waste of rationed material and an unabashed disregard for community values of thrift and sacrifice. Others projected the antiwar sympathies that some black hipsters expressed to all jazz enthusiasts who wore the zoot suit.

In many communities, the zoot suit grew into a powerful symbol of subversion by the mid-1940s, transformed by different sources of tension over changing social

boundaries. As people of color challenged racial barriers across the nation, many whites violently resisted integration. To them, the popularity of the zoot suit seemed to epitomize growing concerns over juvenile delinquency as young people of color increasingly refused to defer to white privilege.

In early June 1943, sailors, soldiers, and some civilians in Los Angeles rioted for a week, setting off a wave of race riots in cities large and small across the nation. The Zoot Suit Riot in Los Angeles was the longest, but the Detroit Race Riot in mid-June was the deadliest. Growing tensions over integration led to a day and a half of rioting, leaving twenty-five blacks and nine whites dead and more than 1,800 arrested. Conversely, in Los Angeles, no murders, rapes, deaths, or serious damage to property were reported in connection with the riot, and only a few cases of serious injury. The mob of mostly white military men seemed focused on reasserting segregation, breached by “uppity” young men of color, by destroying their public displays of wealth and beating those who refused to yield their drapes.

Jazz followed wherever American troops were stationed abroad, and for a moment zoot suits were fashionable among jazz enthusiasts in France, England, and



**Jazz band members in zoot suits, 1942.** Jazz band leader Lionel Hampton shortens a band member's zoot suit on stage. Zoot suits were popular with jazz enthusiasts. © BETTMANN/CORBIS. REPRODUCED BY PERMISSION.



as far away as South Africa. The zoot suit fell out of fashion in the postwar years as the jazz world moved from swing to be-bop, but it served as the inspiration for the Teddy Boys' distinctive look in postwar London.

Decades later the zoot suiter arose immortalized in the dramatic and scholarly works of Chicano artists and intellectuals who saw the wartime generation as cultural nationalists. A zoot suit revival inspired by Luis Valdez's stage and screen musical continues in popular venues, and productions of *Zoot Suit* continue to draw large audiences in the Southwest. Some businesses and Internet sites cater to customers interested in zoot suits, and zoot-suited youth are a staple at some low rider car shows. For many Mexican American youth, putting on the zoot suit serves as a way to connect with a past that was self-assertive and stylish, pay homage to community elders, and assume a place in the continuum of cultural resistance and affirmation.

High-end designers such as Stacey Adams, Vittorio St. Angelo, and Gianni Vironi produce suits that could well be considered next-generation zoot suits. Updated zoot suits no longer elicit the public censure received in the 1940s, because the social context in which the fashion was first received has changed so dramatically.

See also **African American Dress; Latin American Fashion.**

#### BIBLIOGRAPHY

- Capeci, Dominic J., and Martha Wilkerson. *Layered Violence: The Detroit Rioters of 1943*. Jackson: University of Mississippi, 1991.
- Mazón, Mauricio. *The Zoot Suit Riots: The Psychology of Symbolic Annihilation*. Austin: University of Texas, 1984.
- Pagán, Eduardo Obregón. *Murder at the Sleepy Lagoon: Zoot Suits, Race, and Riot in Wartime L.A.* Chapel Hill: University of North Carolina Press, 2003.
- White, Shane, and Graham White. *Stylin': African American Expressive Culture From Its Beginnings to the Zoot Suit*. Ithaca, New York: Cornell University Press, 1998.

Eduardo Pagán

**ZORAN** Zoran Ladicorbic, born in 1947, was an architectural student from Yugoslavia who came to New York and launched an unconventional fashion business in 1976 that stood out for its simple formula of luxurious, casual basics. In contrast to the ornate frocks of Parisian couture that screamed "expensive," Zoran made stark minimalism his signature as he turned out spartan collections of tops, pull-on pants, shift dresses, sarong skirts, and sweaters in sumptuous cashmere, Tasmanian wool, cotton and silk taffeta, and lamé. Zoran's silhouettes never changed, so that a Zoran wardrobe defies the very notion of fashion trends. Zoran calls his fashion formula

"jet pack" fashion: simple styles without zippers, fastenings, or other embellishments. The clothes can be folded flat and tossed into a carry-on suitcase stashed in the overhead compartment of an airplane. Zoran's business is as spare as his fashions; he has neither design assistants nor does he offer secondary lines like jeans and fragrances that round out other designer collections.

In the 1990s, Zoran's business exploded and became one of the top-selling high-fashion brands in stores such as Neiman Marcus, Bergdorf Goodman, and Saks Fifth Avenue. As a luxury brand, Zoran appealed to upscale businesswomen and movie stars such as Isabella Rossellini and Elizabeth Taylor, who preferred the low-key glamour of simple basics that allowed them—and not the clothes—to shine through. His most devoted fans are known as the Zorans. Fashion observers regarded Zoran's minimalist formula as basics for the rich.

Fueling the mystique of Zoran's quirky fashions is his iconoclastic demeanor. As he wears his hair and busy beard long, he has been dubbed fashion's Rasputin. A chain smoker who loves Stolichnaya vodka, Zoran is a confrontational dictator who doesn't believe in fashion's usual conventions. He believes that confident women should simplify their lives and wear flat shoes, no jewelry, and a wash-and-wear haircut—along with his clothes.

Retailers say that the Zoran formula is luxury goods marketing 101. He only sells to one or two stores in every city, which makes his clothes hard to find, and therefore all the more coveted by his fans. As a result, retailers aren't compelled to mark down the goods to fuel sales, as Zoran repeats the same styles year after year so that nothing in his collections looks dated. Because he does no fashion shows and gets very little publicity in the press, shoppers regard his brand as having the ultimate snob appeal—the epitome of "dog whistle fashion," pitched so high that only insiders recognize it.

See also **Department Store; Fashion Designer; Fashion Marketing and Merchandising; Retailing.**

#### BIBLIOGRAPHY

- Agins, Teri. "Uniquely Chic: If Zoran Doesn't Ring a Bell That's Fine with Quirky Designer." *Wall Street Journal*, (5 May 1995).
- . "Outside of the Box: Zoran." In *The End of Fashion: The Mass Marketing of the Clothing Business*. New York: William Morrow and Co., 1999, pp. 247–274.
- Brantley, Ben. "Zoran Zeitgeist." *Vanity Fair*, (March 1992).

Teri Agins

**ZORIS.** See **Sandals.**



# SYSTEMATIC OUTLINE OF CONTENTS

---

This systematic outline provides a general overview of the conceptual scheme of the *Encyclopedia*, listing the titles of each entry. The outline is divided into seven broad subject areas and then subsequent categories within the topic.

- I. History of Clothing
  - A. Regional Dress
  - B. Garments
  - C. Styles
  - D. Costume
  - E. Religious and Ceremonial Dress
  - F. Sportswear
  - G. Occupational Dress
  - H. Protective Clothing
- II. Society
  - A. Class and Social Identity
  - B. Cultures and Groups
  - C. Gender and Personal Identity
  - D. Policy and Government
  - E. Psychology of Dress
- III. History of Accessories
  - A. Accessories
  - B. Jewelry
  - C. Footwear
  - D. Headwear
- IV. Body Modification and Adornment
  - A. Body Modification
  - B. Cosmetics
  - C. Hair
- V. History of Fashion
  - A. Fashion
  - B. Study of Fashion
  - C. Careers in Fashion
  - D. Illustration
  - E. Photography
  - F. Performance
  - G. Art and Literature
  - H. Movements
  - I. Icons
  - J. Writing about Fashion
  - K. Marketing and Merchandising
  - L. Display
- VI. Designers and Design Houses
- VII. Distribution, Materials, and Manufacturing

- A. Production and Distribution
- B. Labor
- C. Fibers, Fabrics, and Textiles
- D. Garment Construction
- E. Processes and Treatments

Because section headings are not mutually exclusive, certain entries in the *Encyclopedia* are listed in more than one section.

## I. HISTORY OF CLOTHING

### A. Regional Dress

- Africa, North: History of Dress
- Africa, Sub-Saharan: History of Dress
- America, Central, and Mexico: History of Dress
- America, North: History of Indigenous Peoples' Dress
- America, South: History of Dress
- Ancient World: History of Dress
- Asia, Central: History of Dress
- Asia, East: History of Dress
- Asia, South: History of Dress
- Asia, Southeastern Islands and the Pacific: History of Dress
- Asia, Southeastern Mainland: History of Dress
- Australian Dress
- China: History of Dress
- Europe and America: History of Dress (400-1900 C.E.)
- Folk Dress, Eastern Europe
- Folk Dress, Western Europe
- India: Clothing and Adornment
- Inuit and Arctic Dress
- Iran: History of Pre-Islamic Dress
- Japanese Traditional Dress and Adornment
- Jewish Dress
- Korean Dress and Adornment
- Latino Style
- Middle East: History of Islamic Dress
- Russia: History of Dress

## SYSTEMATIC OUTLINE OF CONTENTS

Scottish Dress  
Spanish Dress

### **B. Garments**

A-Line Dress  
Ao Dai  
Aprons  
Ball Dress  
Bikini  
Blazer  
Blouse  
Boubou  
Boxer Shorts  
Brassiere  
Breeches  
Burqa  
Bustle  
Caftan  
Chador  
Chemise Dress  
Coat  
Cocktail Dress  
Codpiece  
Corset  
Dashiki  
Djellaba  
Doublet  
Dress Shirt  
Duffle Coat  
Empire Style  
Evening Dress  
G-string and Thong  
Girdle  
Gloves  
Hawaiian Shirt  
Hijab  
Hosiery, Men's  
Jacket  
Jeans  
Jilbab  
Jockey Shorts  
Jumper Dress  
Kaffiyeh  
Kain-kebaya  
Kilt  
Kimono  
Leotard  
Lingerie  
Little Black Dress  
Mantua  
Mao Suit  
Masks  
Miniskirt  
Nehru Jacket  
Nightgown  
Outerwear  
Pagne and Wrapper

Pajamas  
Panties  
Paper Dresses  
Parka  
Penis Sheath  
Petticoat  
Polo Shirt  
Qipao  
Raincoat  
Rainwear  
Robe  
Salwar-Kameez  
Sari  
Sarong  
Scarf  
Shawls  
Shirt  
Shirtwaist  
Shroud  
Skirt  
Slip  
Space Suit  
Sport Shirt  
Sports Jacket  
Stockings, Women's  
Suit, Business  
Sweater  
Sweatshirt  
Swimwear  
Tailored Suit  
Tea Gown  
Toga  
Trousers  
T-Shirt  
Tuxedo  
Underwear  
Veils  
Waistcoat  
Windbreaker  
Yukata  
Zoot Suit

### **C. Styles**

Aesthetic Dress  
Children's Clothing  
Empire Style  
Ethnic Style in Fashion  
Extreme Fashions  
Fancy Dress  
Fetish Fashion  
Folklore Look  
Formal Wear, Men's  
Futurist Fashion, Italian  
Goths  
Grunge  
Heroin Chic  
High-Tech Fashion



Hip-Hop Fashion  
 Hippie Style  
 Historicism and Historical Revival  
 Japonisme  
 Latino Style  
 Macaroni Dress  
 Maternity Dress  
 Military Style  
 Modern Primitives  
 Nautical Style  
 New Look  
 Occult Dress  
 Orientalism  
 Prison Dress  
 Protective Clothing  
 Psychedelic Fashion  
 Punk  
 Retro Styles  
 Roma and Gypsy  
 Space Age Styles  
 Sportswear  
 Street Style  
 Teenage Fashions  
 Travel Clothing  
 Uniforms, Diplomatic  
 Uniforms, Military  
 Uniforms, Occupational  
 Uniforms, School  
 Uniforms, Sports  
 Vintage Fashion  
 Traditional Dress  
 Twentieth-Century Fashion  
 Youthquake Fashions

**D. Costume**

Academic Dress  
 Armor  
 Ballet Costume  
 Bicycle Clothing  
 Bloomer Costume  
 Carnival Dress  
 Clothing, Costume, and Dress  
 Costume Designer  
 Costume Jewelry  
 Court Dress  
 Cowboy Clothing  
 Cross-Dressing  
 Dance Costume  
 Dress for Success  
 Equestrian Costume  
 Fancy Dress  
 Flappers  
 Halloween Costume  
 Legal and Judicial Costume  
 Masks  
 Masquerade and Masked Balls  
 Prison Dress

Reenactors  
 Skating Dress  
 Tennis Costumes  
 Theatrical Costume  
 Theatrical Makeup  
 Veils  
 Wedding Costume  
 Wigs

**E. Religious and Ceremonial Dress**

Ceremonial and Festival Costumes  
 Ecclesiastical Dress  
 Fancy Dress  
 Islamic Dress, Contemporary  
 Jewish Dress  
 Middle East: History of Islamic Dress  
 Mourning Dress  
 Religion and Dress  
 Shroud  
 Traditional Dress  
 Veils  
 Wedding Costume  
 Wigs

**F. Sportswear**

Activewear  
 Bicycle Clothing  
 Dress Reform  
 Equestrian Costume  
 Golf Clothing  
 Helmet  
 Jockey Shorts  
 Nautical Style  
 Polo Shirt  
 Skating Dress  
 Ski Clothing  
 Sneakers  
 Sport Shirt  
 Sport Shoes  
 Sports Jacket  
 Sportswear  
 Swimwear  
 Tennis Costumes  
 Uniforms, Sports

**G. Dress and Occupation**

Casual Business Dress  
 Dress for Success  
 Dress Reform  
 Ecclesiastical Dress  
 Legal and Judicial Costume  
 Military Style  
 Nautical Style  
 Prison Dress  
 Protective Clothing  
 Space Suit  
 Striptease

Suit, Business  
 Tailored Suit  
 Travel Clothing  
 Uniforms, Diplomatic  
 Uniforms, Military  
 Uniforms, Occupational  
 Uniforms, School  
 Uniforms, Sports  
 Working-Class Dress

**H. Protective Clothing**

Outerwear  
 Parka  
 Protective Clothing  
 Rainwear  
 Space Suit  
 Travel Clothing  
 Umbrellas and Parasols  
 Windbreaker

**II. SOCIETY**

**A. Class and Social Identity**

Appearance  
 Barbie  
 Best-Dressed Lists  
 Bloomer Costume  
 Colonialism and Imperialism  
 Court Dress  
 Debutante Dress  
 Demimonde  
 Domestic Production  
 Dress Codes  
 Dress for Success  
 Dress Reform  
 Ethnic Style in Fashion  
 Fancy Dress  
 Fascist and Nazi Dress  
 Fashion and Identity  
 Fashion Dolls  
 Fashion Plates  
 Fashion Shows  
 Fashion Television  
 Flappers  
 Footbinding  
 Gender, Dress, and Fashion  
 Hippie Style  
 Macaroni Dress  
 Mao Suit  
 Mourning Dress  
 Politics and Fashion  
 Prison Dress  
 Royal and Aristocratic Dress  
 Sapeurs  
 Savile Row  
 Secondhand Clothes, Anthropology of  
 Secondhand Clothes, History of

Seventh Avenue  
 Social Class and Clothing  
 Street Style  
 Subcultures  
 Tea Gown  
 Traditional Dress  
 Trendsetters  
 Trickle-Down  
 Uniforms, Diplomatic  
 Uniforms, Military  
 Uniforms, Occupational  
 Uniforms, School  
 Uniforms, Sports  
 Working-Class Dress

**B. Cultures and Groups**

African American Dress  
 Afro Hairstyle  
 Afrocentric Fashion  
 Australian Dress  
 Bohemian Dress  
 Communist Dress  
 Debutante Dress  
 Ethnic Dress  
 Fetish Fashion  
 Flappers  
 Futurist Fashion, Italian  
 Goths  
 Hippie Style  
 Jewish Dress  
 Latino Style  
 Macaroni Dress  
 Occult Dress  
 Prison Dress  
 Punk  
 Roma and Gypsy  
 Royal and Aristocratic Dress  
 Sapeurs  
 Street Style  
 Subcultures  
 Working-Class Dress  
 Youthquake Fashions

**C. Gender and Personal Identity**

Appearance  
 Bloomer Costume  
 Bodybuilding and Sculpting  
 Body Piercing  
 Brassiere  
 Cache-Sexe  
 Codpiece  
 Color in Dress  
 Cowboy Clothing  
 Cross-Dressing  
 Dandyism  
 Dress Reform  
 Fashion and Homosexuality  
 Fashion and Identity

Fetish Fashion  
 Formal Wear, Men's  
 Gender, Dress, and Fashion  
 Macaroni Dress  
 Masks  
 Maternity Dress  
 Nudism  
 Nudity  
 Penis Sheath  
 Shoes, Men's  
 Shoes, Women's  
 Social Class and Clothing  
 Suit, Business  
 Traditional Dress  
 Unisex Clothing  
 Veils

**D. Policy and Government**

Colonialism and Imperialism  
 Communist Dress  
 Dress Codes  
 Fascist and Nazi Dress  
 Globalization  
 Hippie Style  
 Labeling Laws  
 Labor Unions  
 Politics and Fashion  
 Prison Dress  
 Royal and Aristocratic Dress  
 Social Class and Clothing  
 Sumptuary Laws  
 Uniforms, Diplomatic  
 Uniforms, Military  
 Uniforms, Occupational  
 Uniforms, School

**E. Psychology of Dress**

Barthes, Roland  
 Baudrillard, Jean  
 Color in Dress  
 Dress for Success  
 Fashion, Historical Studies of  
 Fashion, Theories of  
 Fashion and Identity  
 Fetish Fashion  
 Flügel, J. C.  
 Gender, Dress, and Fashion  
 Shopping  
 Simmel, Georg  
 Social Class and Clothing  
 Veblen, Thorstein

**III. HISTORY OF ACCESSORIES**

**A. Accessories**

Belts and Buckles  
 Brooches and Pins

Buttons  
 Canes and Walking Sticks  
 Crowns and Tiaras  
 Cuff Links and Studs  
 Eyeglasses  
 Fans  
 Hair Accessories  
 Handbags and Purses  
 Hosiery, Men's  
 Masks  
 Muffs  
 Neckties and Neckwear  
 Outerwear  
 Ribbon  
 Scarf  
 Stockings, Women's  
 Sunglasses  
 Umbrellas and Parasols  
 Veils  
 Watches  
 Wigs

**B. Jewelry**

Beads  
 Body Piercing  
 Bracelets  
 Brooches and Pins  
 Costume Jewelry  
 Crowns and Tiaras  
 Cuff Links and Studs  
 Earrings  
 Jewelry  
 Necklaces and Pendants  
 Rings  
 Watches

**C. Footwear**

Boots  
 Footbinding  
 High Heels  
 Inuit and Arctic Footwear  
 Pointe Shoes  
 Sandals  
 Shoemaking  
 Shoes  
 Shoes, Children's  
 Shoes, Men's  
 Shoes, Women's  
 Sneakers  
 Sport Shoes

**D. Headwear**

Beret  
 Hats, Men's  
 Hats, Women's  
 Headdress  
 Helmet



Hijab  
Masks  
Scarf  
Turban  
Veils  
Wigs

**IV. BODY MODIFICATION AND ADORNMENT**

**A. Body Modification**

Bodybuilding and Sculpting  
Body Piercing  
Branding  
Extreme Fashions  
Fetish Fashion  
Footbinding  
Implants  
Nail Art  
Penis Sheath  
Plastic and Cosmetic Surgery  
Scarification  
Tattoos  
Tight-Lacing

**B. Cosmetics**

Cosmetics, Non-Western  
Cosmetics, Western  
Lipstick  
Makeup Artists  
Nail Art  
Perfume  
Plastic and Cosmetic Surgery  
Theatrical Makeup

**C. Hair**

Afro Hairstyle  
Barbers  
Beards and Mustaches  
Braiding  
Hair Accessories  
Hairdressers  
Hairstyles  
Wigs

**V. HISTORY OF FASHION**

**A. Fashion**

African American Fashion  
Belgian Fashion  
Clothing, Costume, and Dress  
Dress Reform  
Extreme Fashions  
Fads  
Fashion  
Fashion Industry

Fashion Models  
Fashion Museums and Collections  
Future of Fashion  
Gender, Dress, and Fashion  
Haute Couture  
Italian Fashion  
Japanese Fashion  
Latin American Fashion  
London Fashion  
Paris Fashion  
Professional Associations  
Psychedelic Fashion  
Ready-to-Wear  
Savile Row  
Seventh Avenue  
Supermodels  
Trendsetters  
Trickle-Down  
Vintage Fashion  
Vogue  
Women's Wear Daily  
Youthquake Fashions

**B. Study of Fashion**

Baudrillard, Jean  
Color in Dress  
Economics and Clothing  
Extreme Fashions  
Fashion  
Fashion, Attacks on  
Fashion, Historical Studies of  
Fashion, Theories of  
Fashion Advertising  
Fashion and Homosexuality  
Fashion and Identity  
Fashion Designer  
Fashion Editors  
Fashion Education  
Fashion, Health, and Disease  
Fashion Illustrators  
Fashion Industry  
Fashion Journalism  
Fashion Magazines  
Fashion Marketing and Merchandising  
Fashion Models  
Fashion Museums and Collections  
Fashion Online  
Fashion Photography  
Fashion Plates  
Fashion Shows  
Fashion Television  
Fetish Fashion  
Gender, Dress, and Fashion  
Haute Couture  
Hemlines  
Historicism and Historical Revival  
Professional Associations

Ready-to-Wear  
 Savile Row  
 Secondhand Clothes, Anthropology of  
 Secondhand Clothes, History of  
 Seventh Avenue  
 Social Class and Clothing  
 Supermodels  
 Traditional Dress  
 Trendsetters  
 Trickle-Down  
 Twentieth-Century Fashion  
 Vintage Fashion  
 Vogue  
 Women's Wear Daily

**C. Careers in Fashion**

Costume Designer  
 Fashion Advertising  
 Fashion Designer  
 Fashion Editors  
 Fashion Education  
 Fashion Illustrators  
 Fashion Industry  
 Fashion Journalism  
 Fashion Magazines  
 Fashion Marketing and Merchandising  
 Fashion Models  
 Fashion Museums and Collections  
 Fashion Online  
 Fashion Photography  
 Fashion Shows  
 Fashion Television  
 Hairdressers  
 Makeup Artists  
 Milliners  
 Professional Associations  
 Seamstresses  
 Shoemaking  
 Supermodels  
 Textile Workers

**D. Illustration**

Barbier, Georges  
 Caricature and Fashion  
 Fashion Illustrators  
 Fashion Magazines  
 Fashion Plates  
 Godey's Lady's Book  
 Iribe, Paul  
 Vogue

**E. Photography**

Avedon, Richard  
 Beaton, Cecil  
 Bourdin, Guy  
 Dahl-Wolfe, Louise  
 Fashion Magazines  
 Fashion Models

Fashion Photography  
 Horst, Horst P.  
 Hoyningen-Heune, George  
 Meisel, Steven  
 Newton, Helmut  
 Penn, Irving  
 Vogue

**F. Performance**

Actors and Actresses, Impact on Fashion  
 Celebrities  
 Dance and Fashion  
 Dance Costume  
 Fashion Icons  
 Film and Fashion  
 Flappers  
 Hip-Hop Fashion  
 Hollywood Style  
 Madonna  
 Music and Fashion  
 Pointe Shoes  
 Reenactors  
 Striptease  
 Theatrical Costume  
 Theatrical Makeup

**G. Art and Literature**

Art and Fashion  
 Art Nouveau and Art Deco  
 Caricature and Fashion  
 Fashion Illustrators  
 Godey's Lady's Book  
 Vogue  
 Wearable Art  
 Women's Wear Daily

**H. Movements**

Aesthetic Dress  
 Art Nouveau and Art Deco  
 Dandyism  
 Dress Reform  
 Fads  
 Futurist Fashion, Italian  
 Historicism and Historical Revival  
 Japonisme  
 New Look  
 Sapeurs  
 Trendsetters  
 Trickle-Down  
 Youthquake Fashions

**I. Icons**

Barbie  
 Best-Dressed Lists  
 Brummell, George (Beau)  
 Diana, Princess of Wales  
 Fashion Icons  
 Fashion Plates

First Ladies' Gowns  
 Godey's Lady's Book  
 Hollywood Style  
 Madonna  
 Supermodels  
 Trendsetters  
 Twiggy  
 Vogue  
 Wilde, Oscar  
 Windsor, Duke and Duchess of  
 Women's Wear Daily

**J. Writing about Fashion**

Balzac, Honoré de  
 Barthes, Roland  
 Baudelaire, Charles  
 Baudrillard, Jean  
 Benjamin, Walter  
 Best-Dressed Lists  
 Clothing, Costume, and Dress  
 Cunnington, C. Willett and Phillis  
 Demorest, Mme.  
 Fashion, Historical Studies of  
 Fashion, Theories of  
 Fashion Editors  
 Fashion Journalism  
 Fashion Magazines  
 Fashion Online  
 Fashion Plates  
 Flügel, J. C.  
 Future of Fashion  
 Godey's Lady's Book  
 Laver, James  
 Mallarmé, Stéphane  
 Marx, Karl  
 Moore, Doris Langley  
 Proust, Marcel  
 Simmel, Georg  
 Uzanne, Octave  
 Veblen, Thorstein  
 Vogue  
 Wilde, Oscar  
 Women's Wear Daily

**K. Marketing and Merchandising**

Boutique  
 Brands and Labels  
 Department Store  
 Economics and Clothing  
 Fads  
 Fashion Advertising  
 Fashion Editors  
 Fashion Magazines  
 Fashion Marketing and Merchandising  
 Fashion Online  
 Fashion Photography  
 Fashion Plates  
 Fashion Shows

Fashion Television  
 Film and Fashion  
 Logos  
 Ready-to-Wear  
 Retailing  
 Savile Row  
 Seventh Avenue  
 Shopping  
 Supermodels  
 Trendsetters  
 Trickle-Down  
 Twiggy  
 Vogue  
 Window Displays

**L. Display**

Cunnington, C. Willett and Phillis  
 Fashion Models  
 Fashion Museums and Collections  
 Fashion Online  
 Fashion Photography  
 Fashion Plates  
 Fashion Shows  
 Fashion Television  
 Mannequins  
 Moore, Doris Langley  
 Ready-to-Wear  
 Seventh Avenue  
 Supermodels  
 Twiggy  
 Vogue  
 Wearable Art  
 Window Displays

**VI. DESIGNERS AND DESIGN HOUSES**

Adrian  
 Alaïa, Azzedine  
 Albini, Walter  
 Amies, Hardy  
 Armani, Giorgio  
 Balenciaga, Cristóbal  
 Balmain, Pierre  
 Beaton, Cecil  
 Beene, Geoffrey  
 Bertin, Rose  
 Biba  
 Blahnik, Manolo  
 Blass, Bill  
 Brooks Brothers  
 Burberry  
 Burrows, Stephen  
 Callot Sisters  
 Capucci, Roberto  
 Cardin, Pierre  
 Cashin, Bonnie  
 Chalayan, Hussein



Chanel, Gabrielle (Coco)  
 Clark, Ossie  
 Comme des Garçons  
 Courrèges, André  
 de la Renta, Oscar  
 Delaunay, Sonia  
 Demeulemeester, Ann  
 Dior, Christian  
 Dolce & Gabbana  
 Doucet, Jacques  
 Ellis, Perry  
 Fath, Jacques  
 Fendi  
 Ferragamo, Salvatore  
 Fogarty, Anne  
 Fontana Sisters  
 Ford, Tom  
 Fortuny, Mariano  
 Galanos, James  
 Galliano, John  
 Gaultier, Jean-Paul  
 Gernreich, Rudi  
 Gigli, Romeo  
 Givenchy, Hubert de  
 Grès, Mme.  
 Gucci  
 Halston  
 Hartnell, Norman  
 Hawes, Elizabeth  
 Head, Edith  
 Hermès  
 Hilfiger, Tommy  
 Hugo Boss  
 James, Charles  
 Kamali, Norma  
 Karan, Donna  
 Klein, Calvin  
 Lacroix, Christian  
 Lagerfeld, Karl  
 Lang, Helmut  
 Lanvin, Jeanne  
 Lauren, Ralph  
 Leiber, Judith  
 Lesage, François  
 Levi Strauss & Co.  
 Liberty & Co.  
 Lucile  
 Mackie, Bob  
 Mainbocher  
 Margiela, Martin  
 Marimekko  
 Marks & Spencer  
 McCardell, Claire  
 McFadden, Mary  
 McQueen, Alexander  
 Missoni  
 Miyake, Issey

Mori, Hanae  
 Moschino, Franco  
 Mugler, Thierry  
 Muir, Jean  
 Norell, Norman  
 Paquin, Jeanne  
 Patou, Jean  
 Poiret, Paul  
 Prada  
 Pucci, Emilio  
 Quant, Mary  
 Rabanne, Paco  
 Rhodes, Zandra  
 Rykiel, Sonia  
 Saint Laurent, Yves  
 Schiaparelli, Elsa  
 Seydou, Chris  
 Smith, Paul  
 Smith, Willi  
 Steele, Lawrence  
 Sy, Oumou  
 Toledo, Isabel and Ruben  
 Treacy, Philip  
 Trigère, Pauline  
 Valentina  
 Valentino  
 Versace, Gianni and Donatella  
 Viktor & Rolf  
 Vionnet, Madeleine  
 von Furstenberg, Diane  
 Vreeland, Diana  
 Vuitton, Louis  
 Westwood, Vivienne  
 Worth, Charles Frederick  
 Xuly Bët  
 Yamamoto, Yohji  
 Yeohlee  
 Zoran

**VII. DISTRIBUTION, MATERIALS, AND MANUFACTURING**

**A. Production and Distribution**

Boutique  
 Department Store  
 Domestic Production  
 Economics and Clothing  
 Globalization  
 Milliners  
 Ready-to-Wear  
 Seamstresses  
 Secondhand Clothes, Anthropology of  
 Secondhand Clothes, History of  
 Sewing Machine  
 Shoemaking  
 Shopping  
 Sweatshops

## SYSTEMATIC OUTLINE OF CONTENTS

Tailoring  
Textiles and International Trade  
Textile Workers

### **B. Labor**

Domestic Production  
Garments, International Trade in  
Globalization  
Labor Unions  
Milliners  
Seamstresses  
Shoemaking  
Sweatshops  
Textile Workers  
Working-Class Dress

### **C. Fibers, Fabrics, and Textiles**

Acrylic and Modacrylic Fibers  
Adinkra  
Adire  
Agbada  
Alpaca  
Appliqué  
Angora  
Animal Prints  
Bark Cloth  
Batik  
Beads  
Calico  
Cambric, Batiste, and Lawn  
Camel Hair  
Camouflage Cloth  
Cashmere and Pashmina  
Chintz  
Corduroy  
Cotton  
Crepe  
Crinoline  
Denim  
Elastomers  
Feathers  
Felt  
Fibers  
Flannel  
Fur  
Gabardine  
Handwoven Textiles  
Hemp  
Homespun  
Ikat  
Jersey  
Kanga  
Kente  
Lace  
Leather and Suede  
Linen  
Microfibers

Mohair  
Muslin  
Nonwoven Textiles  
Nylon  
Oilskins  
Olefin Fibers  
Paisley  
Plaid  
Polyester  
Ramie  
Rayon  
Recycled Textiles  
Ribbon  
Rubber as Fashion Fabric  
Silk  
Spangles  
Striped Cloth  
Tapestry  
Tartan  
Techno-Textiles  
Textiles, African  
Textiles, Andean  
Textiles, Byzantine  
Textiles, Central Asian  
Textiles, Chinese  
Textiles, Coptic  
Textiles, Japanese  
Textiles, Middle Eastern  
Textiles, Prehistoric  
Textiles, South Asian  
Textiles, Southeast Asian Islands  
Textiles, Southeast Asian Mainland  
Textiles and International Trade  
Textile Workers  
Trimmings  
Tweed  
Velvet  
Vinyl as Fashion Fabric  
Wool  
Yarns

### **D. Garment Construction**

Closures, Hook-and-Loop  
Cutting  
Fasteners  
Hemlines  
Mannequins  
Needles  
Patterns and Patternmaking  
Pins  
Pockets  
Safety Pins  
Sewing Machine  
Skirt Supports  
Tailored Suit  
Tailoring  
Trimmings  
Zipper

**E. Processes and Treatments**

Batik  
 Braiding  
 Crochet  
 Distressing  
 Dry Cleaning  
 Dyeing  
 Dyeing, Resist  
 Dyes, Chemical and Synthetic  
 Dyes, Natural  
 Embroidery  
 Flocking  
 Fulling  
 Glazing  
 Homespun  
 Ikat  
 Indigo  
 Knitting  
 Knitting Machinery  
 Knotting  
 Laundry

Loom  
 Napping  
 Performance Finishes  
 Quilting  
 Recycled Textiles  
 Spinning  
 Spinning Machinery  
 Tailoring  
 Tanning of Leather  
 Tie-Dyeing  
 Weave, Double  
 Weave, Jacquard  
 Weave, Pile  
 Weave, Plain  
 Weave, Satin  
 Weave, Slack Tension  
 Weave, Twill  
 Weave Types  
 Weaving  
 Weaving, Machinery  
 Worsted





# DIRECTORY OF CONTRIBUTORS

---

**Isabella A. Abbott**

Bark Cloth

**Thomas S. Abler**

*Department of Anthropology,  
University of Waterloo*  
Uniforms, Military

**Teri Agins**

*Wall Street Journal*  
Garments, International Trade in  
Zoran

**Heather Marie Akou**

*University of Minnesota, Twin Cities*  
Islamic Dress, Contemporary  
Jilbab  
Weave, Jacquard  
Weave, Plain  
Weave, Satin  
Weave, Twill

**Ann Ilan Alter**

Masquerade and Masked Balls

**Fiona Anderson**

*National Museums of Scotland*  
Plaid  
Scottish Dress  
Shawls  
Shoes, Men's  
Tartan  
Tweed

**Joanne Arbuckle**

*Fashion Institute of Technology*  
Closures, Hook-and-Loop

**Rebecca Arnold**

*Senior lecturer in fashion and theory,  
Central Saint Martins College of Art  
and Design, London*  
Heroin Chic  
Vionnet, Madeleine  
Westwood, Vivienne

**Linda B. Arthur**

*Washington State University*  
Asia, Southeastern Islands and  
the Pacific: History of Dress  
Hawaiian Shirt  
Religion and Dress

**Juliet Ash**

*Tutor in Fashion/Textiles Critical &  
Historical Studies, Royal College of Art,  
London, U.K.*  
Prison Dress

**Sonia Ashmore**

*Research fellow, London College of  
Fashion, University of the Arts, London*  
Liberty & Co.

**Jane Audas**

*Royal College of Art, London*  
Mannequins  
Window Displays

**Patricia L. Baker**

Iran, History of Pre-Islamic  
Dress  
Middle East: History of Islamic  
Dress

**Mukulika Banerjee**

*University College, London, U.K.*  
Sari

**E. J. W. Barber**

*Professor of Archeology and Linguistics,  
Occidental College, Los Angeles*  
Textiles, Prehistoric

**Ruth Barcan**

*Department of Gender Studies,  
University of Sydney, Australia*  
Nudism  
Nudity

**Ruth Barnes**

*Researcher, Department of Eastern Art,  
Ashmolean Museum, Oxford*  
Ikat

**Claire Barratt**

*Central Saint Martins, University of  
the Arts, London*  
Shroud

**Djurdja Bartlett**

*Independent scholar*  
Communist Dress

**Beatrix Bastl**

Royal and Aristocratic Dress

**Reed Benhamou**

*Department of Apparel Merchandising  
and Interior Design, Indiana  
University*  
Sumptuary Laws

**Lenore Benson**

Fashion Editors  
Professional Associations

**Parminder Bhachu**

*Clark University, Massachusetts*  
Salwar-Kameez

**Vandana Bhandari**

*Associate Professor, Fashion and  
Textiles Department, National Institute  
of Fashion Technology*  
Turban

**Martin Bide**

*Department of Textiles, Fashion  
Merchandising and Design, University  
of Rhode Island*  
Acrylic and Modacrylic Fibers  
Elastomers  
Olefin Fibers

**Thomas A. Bilstad**

*Professional copy editor, freelance author*  
Occult Dress

**Anne Bissonnette**

*Curator, Kent State University Museum*  
Tea Gown

**Sandy Black**

*Reader in Knitwear and Fashion, London College of Fashion, University of the Arts, London*  
Sweater

**Whitney Blausen**

*Independent researcher*  
Costume Designer  
Spangles  
Theatrical Costume

**Heidi Boehlke**

Batik  
Kain-kebaya  
Sarong

**Andrew Bolton**

*Associate Curator, The Costume Institute, The Metropolitan Museum of Art*  
Kilt  
Windsor, Duke and Duchess of

**Laird Borrelli**

*Senior Fashion Editor, Style.com*  
Fashion Illustrators  
Fashion Online  
Trendsetters  
Vogue

**Marie Botkin**

*Apparel Marketing and Design, Family and Consumer Science, California State University, Sacramento*  
Corduroy  
Flannel  
Jersey  
Napping

**G. Bruce Boyer**

*Fashion Writer and Editor*  
Brooks Brothers

**Ann W. Braaten**

*North Dakota State University*  
Alpaca  
Angora  
Camel Hair  
Mohair  
Wool  
Worsted

**Archie Brennan**

Tapestry

**Christopher Breward**

*London College of Fashion*  
London Fashion  
Savile Row  
Wilde, Oscar

**Claudia Brown**

*Arizona State University*  
Textiles, Chinese

**Stella Bruzzi**

*Professor of Film Studies at Royal Holloway, University of London*  
Film and Fashion

**Michele Wesen Bryant**

*Fashion Institute of Technology*  
Rubber as Fashion Fabric

**Vern L. Bullough**

Cross-Dressing  
Plastic and Cosmetic Surgery

**Barbara Burman**

*University of Southampton, U.K.*  
Domestic Production  
Pockets  
Seamstresses  
Working-Class Dress

**Jeffrey A. Butterworth**

Shoes, Children's

**Elizabeth K. Bye**

*University of Minnesota*  
High-Tech Fashion  
Nautical Style

**Colleen R. Callahan**

*Curator Emeritus, The Valentine Richmond History Center*  
Bloomer Costume  
Children's Clothing  
Godey's Lady's Book  
Outerwear

**Gillion Carrara**

*Director of the Fashion Resource Center*  
Ferragamo, Salvatore  
Fortuny, Mariano  
Gucci  
Italian Fashion  
Missoni  
Moschino, Franco  
Steele, Lawrence  
Versace, Gianni and Donatella

**Michael Carter**

*Department of Art History and Theory, University of Sydney*  
Flügel, J. C.  
Laver, James  
Veblen, Thorstein

**Frank Cartledge**

*Senior Lecturer, Chelsea College of Art, University of the Arts, London*  
Punk

**Anna Beatriz Chadour-Sampson**

*Freelance jewelry historian and scholarly author, England, U.K.*  
Jewelry  
Rings

**Gary Chaison**

*Professor of Industrial Relations, Clark University, Worcester, Massachusetts*  
Sweatshops

**Angel Chang**

*Design Assistant: Fabric Development and Creative Direction, The Donna Karan Company*  
Delaunay, Sonia  
Sport Shoes  
Viktor & Rolf

**Beth Dincuff Charleston**

Klein, Calvin

**Xavier Chaumette**

Gaultier, Jean-Paul  
Tailored Suit

**Joyce Cheney**

*Focus Communications/American Association of Museums/National Association of Museum Exhibition*  
Aprons

**Beverly Chico**

*Regis University, School for Professional Studies*

Beret  
Chador  
Hats, Women's  
Headdress  
Helmet

**Kimberley Chrisman-Campbell**

*Huntington Library, San Marino, California*

Bertin, Rose

**Alice Cicolini**

*Curator and Project Manager, Design, British Council*

Dandyism  
Historicism and Historical Revival  
Stockings, Women's  
Vintage Fashion

**Shaun Cole**

*Victoria & Albert Museum*

Jockey Shorts  
Fashion and Homosexuality

**Elizabeth Ann Coleman**

*Museum of Fine Arts*

Doucet, Jacques  
Fashion Dolls  
James, Charles  
Worth, Charles Frederick

**Billie J. Collier**

*University of Tennessee*

Microfibers  
Nonwoven Textiles  
Performance Finishes  
Yarns

**John R. Collier**

*University of Tennessee*

Spinning Machinery

**Caroline Cox**

*Vidal Sassoon Advanced Academy*

Barbers  
Beards and Mustaches  
G-string and Thong  
Lingerie  
Panties  
Petticoat  
Underwear  
Wigs

**Maxine Leeds Craig**

*California State University, Hayward*

Afro Hairstyle

**Patricia Cox Crews**

*Cather Professor of Textiles and Director, International Quilt Study Center, University of Nebraska, Lincoln*

Quilting

**Oriole Cullen**

*Museum of London*

Aesthetic Dress  
Fath, Jacques

**Elyssa Schram Da Cruz**

*Research Associate, The Costume Institute, The Metropolitan Museum of Art*

Cocktail Dress

**M. Catherine Daly**

Veils

**Mary Lynn Damhorst**

*Department of Textiles and Clothing, Iowa State University*

Casual Business Dress

**Alison Matthews David**

*Centre for the History of Textiles and Dress, University of Southampton*

Balzac, Honoré de  
Brummell, George (Beau)  
Equestrian Costume  
Tailoring

**Kaat Debo**

*Curator Contemporary Fashion MoMu*

Belgian Fashion  
Demeulemeester, Ann  
Margiela, Martin

**Amy de la Haye**

*London College of Fashion*

Chanel, Gabrielle (Coco)  
Muir, Jean  
Patou, Jean  
Quant, Mary

**Marilyn Revell DeLong**

*University of Minnesota, Saint Paul*

Color in Dress  
Fashion, Theories of  
Korean Dress and Adornment

**Marilee DesLauriers**

*The Goldstein Museum of Design, University of Minnesota*

Embroidery  
Marimekko

**Jasleen Dhamija**

Asia, Central: History of Dress

Asia, South: History of Dress  
Paisley  
Textiles, Central Asian

**Kitty G. Dickerson**

*Department of Textile and Apparel Management, University of Missouri, Columbia*

Textiles and International Trade

**Carol A. Dickson**

*Apparel Product Design and Merchandising, University of Hawaii-Manoa*

Bark Cloth  
Denim  
Hemp

**Jean L. Druesedow**

*Kent State University Museum*

Ready-to-Wear  
Trigère, Pauline

**Robin Dutt**

Formal Wear, Men's

**Bronwen Edwards**

Department Store  
Shopping

**Edwina Ehrman**

*Curator of Dress and Decorative Art, Museum of London*

Amies, Hardy  
Hartnell, Norman

**Joanne B. Eicher**

*University of Minnesota*

Africa, Sub-Saharan: History of Dress  
Clothing, Costume, and Dress  
Ethnic Dress

**Fadwa El Guindi**

*University of Southern California*

Djellaba  
Hijab  
Kaffiyeh



**Julia Emberley**

*Professor in English, University of Western Ontario*  
Fur

**Joy Spanabel Emery**

*Theatre University of Rhode Island*  
Patterns and Patternmaking

**Joanne Entwistle**

*Lecturer, University of Essex*  
Dress for Success  
Fashion, Attacks on

**Caroline Evans**

*Reader in Fashion Studies, Central Saint Martins College of Art and Design, The University of the Arts, London*  
Fashion Models  
McQueen, Alexander  
Schiaparelli, Elsa

**Sandra Lee Evenson**

*University of Idaho*  
Cache-Sexe  
Codpiece  
Penis Sheath

**William Ewing**

Avedon, Richard  
Horst, Horst P.  
Hoyningen-Huene, George

**Jane Farrell-Beck**

*Textiles and Clothing Program, Iowa State University*  
Girdle

**Brigitte Felderer**

Gernreich, Rudi

**Gretchen Fenston**

*Registrar, Condé Nast Archive*  
Klein, Calvin

**Mary Ann C. Ferro**

*Associate Professor, Fashion Institute of Technology*  
Vinyl as Fashion Fabric

**Michelle Tolini Finamore**

*Rhode Island School of Design*  
Callot Sisters  
Iribe, Paul  
Fashion Shows  
Vreeland, Diana

**Aurora Fiorentini**

Armani, Giorgio  
Valentino

**Lynda Fitzwater**

*M.A. in Fashion Theory from London College of Fashion*  
Secondhand Clothes, History of

**Marnie Fogg**

*M.A.*  
De la Renta, Oscar  
McFadden, Mary  
Rhodes, Zandra  
Rykiel, Sonia  
Smith, Paul  
Smith, Willi  
Suit, Business  
Treacy, Philip  
von Furstenberg, Diane

**Katherine Forde**

Nail Art

**Helen Bradley Foster**

*University of Minnesota*  
African American Dress

**Ed Franquemont**

Textiles, Andean

**Robert Friedel**

*University of Maryland*  
Zipper

**Phyllis Galembo**

*Professor, Fine Arts Department, University at Albany, State University of New York*  
Halloween Costume

**Lorraine Gamman**

*Reader Design Context, School of Graphic and Industrial Design, Central St. Martins College of Art and Design*  
Laundry

**Philippe Garner**

Newton, Helmut

**Colleen Gau**

*Independent historian*  
Brassiere  
Corset

**Liz Gessner**

*Freelance fashion writer, formerly editor of W Magazine and Women's Wear Daily*  
Blahnik, Manolo  
Karan, Donna  
Little Black Dress

**Key Sook Geum**

*Hong-ik University, Seoul, South Korea*  
Korean Dress and Adornment

**Donna Gheleter**

*Costume and Textile historian, NYC*  
Future of Fashion  
Norell, Norman  
Scarf

**Pamela Church Gibson**

*Senior Lecturer, London College of Fashion*  
Actors and Actresses, Impact on Fashion  
Celebrities  
Fashion Icons  
Hollywood Style  
Proust, Marcel  
Twiggy

**Madeleine Ginsberg**

Fashion Magazines  
Fashion Plates

**Jessica Glasscock**

*Author of Striptease: From Gaslight to Spotlight*  
Striptease

**Pamela Golbin**

*Curator, The Musée de la Mode et du Textiles, Paris*  
Lacroix, Christian  
Saint Laurent, Yves

**Ch. Didier Gondola**

*Indiana University, Indianapolis*  
Sapeurs

**Tom Greatrex**

*London, U.K.*  
Blazer  
Boxer Shorts  
Coat

**Tom Greatrex** *(continued)*

Dress Shirt  
Duffle Coat  
Jacket  
Oilskins  
Parka  
Polo Shirt  
Raincoat  
Rainwear  
Shirt  
Sport Shirt  
Sports Jacket  
Waistcoat  
Windbreaker

**Annette Green**

*President Emeritus, The Fragrance Foundation. Shipman School of Journalism, NYU, The New School*  
Perfume

**Rebecca L. Green**

*Associate Professor and Chair of Art History, Bowling Green State University*  
Kanga

**Susan W. Greene**

*American Costume Studies, Alfred Station, NY*  
Calico  
Cambric, Batiste, and Lawn  
Crepe  
Indigo  
Muslin

**Michael Gross**

*Contributing editor of Travel and Leisure, contributing writer for Radar*  
Lauren, Ralph  
Supermodels

**Irene Guenther**

*Professor, Department of History, Houston Community College-Northwest*  
Fascist and Nazi Dress

**Elisabeth Hackspiel-Mikosch**

*Lecturer at the Niederrhein University of Applied Sciences, Moenchengladbach, Germany*  
Uniforms, Diplomatic  
Uniforms, Occupational

**Nancy Hall-Duncan**

*Curator, Bruce Museum of Arts and Science, Greenwich, Conn.*  
Beaton, Cecil  
Bourdin, Guy  
Dahl-Wolfe, Louise  
Fashion Photography  
Meisel, Steven

**Karen Tranberg Hansen**

*Department of Anthropology, Northwestern University*  
Colonialism and Imperialism  
Secondhand Clothes,  
Anthropology of

**Marin F. Hanson**

*Assistant curator, International Quilt Study Center, University of Nebraska, Lincoln*  
Quilting

**Leslie Harris**

*Independent scholar, London, U.K.*  
Canes and Walking Sticks  
Legal and Judicial Costume  
Watches

**Avril Hart**

*Assistant Curator of the Department of Textiles and Dress, Victoria & Albert Museum*  
Fans

**H. Kristina Haugland**

*Philadelphia Museum of Art*  
Blouse  
Bustle  
Crinoline  
Leotard  
Nightgown  
Skirt  
Skirt Supports  
Slip

**Jana M. Hawley**

*Textile and Apparel Management, University of Missouri*  
Recycled Textiles

**Micheale Haynes**

*Curator of History and Textiles, Witte Museum of San Antonio*  
Debutante Dress

**Thomas Hecht**

*Central School of Speech and London College of Fashion*  
Ballet Costume  
Dance and Fashion  
Dance Costume  
Hugo Boss  
Lang, Helmut  
Pointe Shoes

**Joyce Heckman**

Fads

**Jane E. Hegland**

*Department Head and Associate Professor, Apparel Merchandising and Interior Design, South Dakota State University*  
Ball Dress  
Evening Dress  
Fashion Education

**Barbara Perso Heinemann**

*University of Minnesota*  
Jumper Dress

**Paula Heinonen**

*IGS (CCCRW), University of Oxford*  
Cosmetics, Non-Western

**Janet Hethorn**

*University of Delaware*  
Skating Dress

**Robert Hillestad**

*University of Nebraska, Lincoln*  
Appearance

**Bette Hochberg**

Spinning

**Paul Hodkinson**

*University of Surrey, England*  
Goths

**Susie Hopkins**

*London College of Fashion*  
Crowns and Tiaras  
Hats, Men's  
Milliners

**Catherine Horwood**

*Royal Holloway, University of London*  
Tennis Costumes

**Nancy Arthur Hoskins**

*Coptic researcher, former weaving instructor, and author of The Coptic Tapestry Albums and the Archaeologist of Antinoé*  
Textiles, Coptic

**Stephanie Day Iverson**

*University of California, Los Angeles*  
Cashin, Bonnie

**Anthea Jarvis**

*Curator, Gallery of Costume, Platt Hall, Manchester, U.K.*  
Fancy Dress

**Charlotte Jirousek**

*Cornell University*  
Textiles, Middle Eastern

**Paul Jobling**

*The School of Historical and Critical Studies, University of Brighton, U.K.*  
Fashion Advertising

**Anna Johnson**

Handbags and Purses

**Kim K. P. Johnson**

*University of Minnesota*  
Politics and Fashion

**Lucy Johnston**

*Curator of nineteenth century fashion and wedding dress, Victoria & Albert Museum*  
Ski Clothing

**Alan Cannon Jones**

*F.FCDE (Fellow, Federation of Clothing Designers and Executives)*  
Cutting

**Esther Juhasz**

*Hebrew University, Israel*  
Jewish Dress

**Sara J. Kadolph**

*Textiles and Clothing, Department of Apparel, Educational Studies, and Hospitality Management, Iowa State University*  
Chintz  
Dyeing  
Dyes, Natural  
Gabardine

**Susan B. Kaiser**

*University of California at Davis*  
Fads  
Fashion and Identity  
Trickle-Down

**Lydia Kamitsis**

*Fashion historian; independent fashion curator*  
Lesage, François  
Rabanne, Paco

**Walter Karcheski**

*Chief curator of arms and armor, Frazier Historical Arms Museum, Louisville, Kentucky*  
Armor

**Denise Kastrinakis**

Fads

**Yuniya Kawamura**

*State University of New York, Fashion Institute of Technology*  
Japanese Fashion  
Miyake, Issey  
Mori, Hanae

**Alan Kennedy**

*Independent researcher, contributing editor, Hali*  
Japanese Traditional Dress and Adornment  
Kimono  
Yukata

**Shirley Kennedy**

*Fashion Art Bank Inc., founding partner*  
Pucci, Emilio

**Claudia Kidwell**

First Ladies' Gowns

**Raisa Kirsanova**

Russia: History of Dress

**Rosanne Klass**

*Director, Afghanistan Information Center, Freedom House, New York, 1980–1991*  
Burqa

**Dorothy Ko**

*Barnard College, Columbia University*  
Footbinding

**Anna König**

*Associate Lecturer, London College of Fashion*  
Neckties and Neckwear  
Umbrellas and Parasols

**Désirée Koslin**

*Fashion Institute of Technology*  
Textiles, Byzantine  
Velvet

**Colleen E. Kriger**

*University of North Carolina at Greensboro*  
Robe

**Youn Kyung-Kim**

Recycled Textiles

**Karen L. LaBat**

*University of Minnesota*  
Asia, Southeastern Mainland:  
History of Dress  
Bicycle Clothing  
Fasteners  
High-Tech Fashion

**John Lappe**

*President, Museum Quality Speciality Drycleaning Services*  
Dry Cleaning

**Babatunde Lawal**

*Department of Art History, Virginia Commonwealth University*  
Agbada  
Carnival Dress

**Seung-Eun Lee**

*University of Minnesota*  
Retailing

**Leedom Lefferts**

*Drew University, Madison, New Jersey*  
Textiles, Southeast Asian  
Mainland

**Ulrich Lehmann**

*Royal College of Art, Victoria & Albert Museum*  
Art and Fashion  
Benjamin, Walter  
Futurist Fashion, Italian  
Mallarmé, Stéphane  
Simmel, Georg



**Ann Marie Leshkovich**  
*Assistant Professor of Anthropology,  
 College of the Holy Cross  
 Ao Dai*

**Esther Leslie**  
*Lecturer, School of English and  
 Humanities, Birkbeck, University of  
 London, U.K.  
 Marx, Karl*

**Van Dyk Lewis**  
*Assistant Professor, Textiles and  
 Apparel, Cornell University  
 Afrocentric Fashion  
 Hip-Hop Fashion  
 Music and Fashion*

**Joel Lobenthal**  
*Independent Writer  
 Hippie Style  
 Psychedelic Fashion  
 Space Age Styles  
 Youthquake Fashions*

**Linda Loppa**  
*Director and Chief Curator MoMu  
 Belgian Fashion  
 Demeulemeester, Ann  
 Margiela, Martin*

**Ingrid Loschek**  
*Professor of history and theory of  
 fashion, University of Applied Sciences  
 in Pforzheim, Germany  
 Twentieth-Century Fashion*

**Elizabeth D. Lowe**  
*City University of New York, Queens  
 College  
 Feathers  
 Labeling Laws  
 Polyester  
 Ramie*

**Marylou Luther**  
*Editor-in-chief of the International  
 Fashion Syndicate  
 Fashion Journalism  
 Retro Styles*

**Hazel Lutz**  
*Independent scholar of textiles, dress  
 and South Asia  
 India: Clothing and Adornment  
 Nehru Jacket*

**Karmen MacKendrick**  
*Department of Philosophy, Le Moyne  
 College  
 Body Piercing*

**Phyllis Magidson**  
*Curator of Costumes and Textiles,  
 Museum of the City of New York  
 Mainbocher*

**Michele Majer**  
*Assistant Professor, Bard Graduate  
 Center  
 Barbier, Georges  
 Boutique  
 Demimonde  
 Moore, Doris Langley*

**John S. Major**  
*China Institute  
 Asia, East: History of Dress  
 Balmain, Pierre  
 Blass, Bill  
 Camouflage Cloth  
 China, History of Dress  
 Givenchy, Hubert de  
 Lagerfeld, Karl  
 Mugler, Thierry  
 Paris Fashion  
 Prada  
 Striped Cloth  
 Textiles, Japanese  
 Yeohlee*

**Joanna Marschner**  
*Kensington Palace, State Apartments  
 and Royal Ceremonial Dress Collection  
 Court Dress*

**Margaret Maynard**  
*The University of Queensland, Australia  
 Australian Dress*

**Joanne McCallum**  
*Bachelor of Design Studies Honours  
 Class 1, The University of Queensland  
 Academic Dress  
 Cuff Links and Studs*

**Aliecia R. McClain**  
 Distressing

**Catherine McDermott**  
*Art, Design, and Music, Kingston  
 University  
 Diana, Princess of Wales*

**Elizabeth McLafferty**  
 Lipstick  
 Makeup Artists  
 Theatrical Makeup

**Peter McNeil**  
*University of New South Wales, Sydney,  
 School of Art History and Theory  
 Caricature and Fashion  
 Macaroni Dress*

**Brian J. McVeigh**  
*University of Arizona  
 Dress Codes  
 Uniforms, School*

**Patricia Mears**  
 Grès, Mme.  
 Japonisme  
 Orientalism  
 Yamamoto, Yohji

**Beatrice Medicine**  
 America, North: History of  
 Indigenous Peoples' Dress

**Katalin Medvedev**  
 Social Class and Clothing

**Lynn A. Meisch**  
*Associate Professor of Anthropology,  
 Saint Mary's College of California  
 America, South: History of  
 Dress*

**Dean L. Merceron**  
*M.A. from the Fashion Institute of  
 Technology, Museum Studies: Costume  
 and Textiles  
 Lanvin, Jeanne*

**Susan O. Michelman**  
*University of Kentucky  
 Gender, Dress, and Fashion*

**Caroline Rennolds Milbank**  
 Ellis, Perry  
 Hermès  
 Poiret, Paul

**Daniel Miller**  
 Sari

**Lesley Ellis Miller**  
*University of Southampton, U.K.  
 Balenciaga, Cristóbal  
 Spanish Dress*

**Kimberly A. Miller-Spillman**  
Gender, Dress, and Fashion

**Josephine Moreno**  
*University of California, Berkeley*  
Latino Style

**David Muggleton**  
*University College, Chichester, U.K.*  
Subcultures

**Robert Muir**  
Penn, Irving

**Hudita Mustafa**  
*Department of Anthropology, Emory University*  
Sy, Oumou

**Nan H. Mutnick**  
*Chair, Department of Human Ecology, Marymount College of Fordham University*  
Appliqué

**Michelle Nordtorp-Madson**  
*University of St. Thomas, St. Paul, Minn.*  
Wedding Costume

**Jill Oakes**  
*Department of Environmental Studies and Geography, Faculty of Environment, University of Manitoba, Winnipeg, Canada*  
Inuit and Arctic Dress  
Inuit and Arctic Footwear

**Alden O'Brien**  
*D.A.R. Museum*  
Empire Style  
Maternity Dress  
Travel Clothing

**Sean O'Mara**  
Laundry

**Alistair O'Neill**  
*London College of Fashion*  
Burberry  
Ford, Tom  
Lucile  
Tuxedo  
Vuitton, Louis

**Bill Osgerby**  
Teenage Fashion

**Janet Ozzard**  
Women's Wear Daily

**Eduardo Obregon Pagán**  
*Arizona State University West*  
Zoot Suit

**Alexandra Palmer**  
*Nora Vaughan Fashion Costume Curator, Textile section, Royal Ontario Museum, Toronto, Canada*  
Haute Couture

**Jennifer Park**  
*Fashion Institute of Technology, Museum*  
Courrèges, André  
Sweatshirt  
Unisex Clothing

**Pamela A. Parmal**  
*Department of Textile and Fashion Arts, Museum of Fine Arts, Boston*  
Hemlines  
Lace  
Ribbon

**Christopher M. Pastore**  
*Philadelphia University*  
Techno-textiles

**Kathleen Paton**  
*Freelance writer and editor*  
Best-Dressed Lists  
Paper Dresses  
Trimnings

**Jane M. Pavitt**  
*University of Brighton, Victoria & Albert Museum*  
Brands and Labels  
Logos

**Kathy Peiss**  
*University of Pennsylvania*  
Cosmetics, Western

**Nicole Pellegrin**  
Barthes, Roland

**Simioan Petrovan**  
*University of Tennessee*  
Spinning Machinery

**Lindsey Philpott**  
*President, Pacific Americas Branch of the International Guild of Knot Tyers*  
Knotting

**John Picton**  
*School of Oriental and African Studies, University of London*  
Textiles, African

**Uraivan Pitmaneeyakul**  
*King Mongkut's Institute of Technology Asia, Southeastern Mainland:*  
History of Dress

**Ted Polhemus**  
*Independent scholar, teacher and lecturer*  
Street Style

**Shannon Bell Price**  
*The Costume Institute, The Metropolitan Museum of Art*  
Grunge

**Eric Pujalet-Plaà**  
*Musée de la mode et du textile, Union centrale des arts décoratifs, Palais du Louvre*  
Dior, Christian  
New Look

**Bradley Quinn**  
*Independent scholar and freelance curator*  
Activewear  
Bodybuilding and Sculpting  
Chalayan, Hussein

**Leslie W. Rabine**  
*University of California, Davis*  
Boubou  
Globalization  
Pagne and Wrapper

**Erica Rand**  
*Department of Art and Visual Culture, Bates College*  
Barbie

**Jan Glier Reeder**  
*Consultant, The Costume Institute, Metropolitan Museum of Art*  
*Appraisers Association of America*  
Paquin, Jeanne

**Simona Segre Reinach**

*IULM University, Milan, Italy*  
Albini, Walter  
Capucci, Roberto  
Dolce & Gabbana  
Fendi  
Fontana Sisters  
Gigli, Romeo

**Elisha P. Renne**

*University of Michigan, Ann Arbor*  
Ecclesiastical Dress

**Victoria Z. Rivers**

*Design Program, University of California–Davis*  
Textiles, South Asian

**Janet Rizvi**

*Historian, freelance researcher, and writer specializing in the Western Himalaya, especially Kashmir and Ladakh*  
Cashmere and Pashmina  
Paisley

**Regina A. Root**

*College of William and Mary*  
Latin American Fashion

**Doran H. Ross**

Adinkra  
Kente

**Fred Rottman**

*Executive VP of Picchi Mills (Italian textile company)*  
Halston

**Victoria L. Rovine**

*University of Iowa Museum of Art, Curator of the Arts of Africa, Oceania, and the Americas*  
Bogolan  
Seydou, Chris  
Xuly Bët

**Carol J. Salusso**

*International Textiles and Apparel Association; Washington State University*  
Cotton  
Linen  
Nylon  
Rayon  
Silk

**Clare Sauro**

*Curatorial Assistant, The Museum at the Fashion Institute of Technology*  
Boots  
Flappers  
Head, Edith  
Jeans  
Pajamas  
Mackie, Bob

**Margot Blum Schevill**

*Curator, San Francisco Airport Museums*  
America, Central, and Mexico:  
History of Dress

**Mark Schultz**

*Curatorial specialist, Goldstein Museum of Design, University of Minnesota*  
Belts and Buckles

**Lidia D. Sciama**

*Senior Associate of Queen Elizabeth House, Oxford, U.K.*  
Beads

**Karen Searle**

Handwoven Textiles

**Dennita Sewell**

Animal Prints  
Burrows, Stephen  
Mantua  
T-Shirt

**Julia Sharp**

*Centenary College, Hackettstown, N.J.; Queens College, N.Y.*  
Felt

**Rebecca Shawcross**

*Assistant Shoe Resources Officer, Northampton Museum and Art Gallery, U.K.*  
High Heels

**Lindsay Shen**

*Director, Goldstein Museum of Design, University of Minnesota*  
Crochet  
Embroidery  
Knitting

**Jody Shields**

Costume Jewelry

**Margot Siegel**

Seventh Avenue

**Lise Skov**

*Post-doctoral research fellow, Department of Sociology, Copenhagen University*  
Ethnic Style in Fashion

**Orpa Slapak**

*Israel Museum, Jerusalem*  
Jewish Dress

**Fred T. Smith**

*Kent State University*  
Ceremonial and Festival  
Costumes  
Masks

**Jan Rawdon Smith**

*The Braid Society*  
Braiding

**Susan L. Sokolowski**

*Nike, Inc. Beaverton, Oregon*  
Sneakers  
Uniforms, Sports

**Christopher Spring**

*Curator, Ethnography Department British Museum*  
Africa, North: History of Dress

**Jo Ann C. Stabb**

*University of California–Davis*  
Tie-Dyeing

**Kristina Stankovski**

Dress Reform  
Gloves

**Valerie Steele**

*Fashion Institute of Technology*  
Baudelaire, Charles  
Corset  
Fashion  
Fashion Museums and  
Collections  
Fetish Fashion  
Italian Fashion  
Leiber, Judith  
Paris Fashion  
Tight-Lacing  
Toledo, Isabel and Ruben  
Uzanne, Octave

**Francesca Sterlacci**

*Fashion Institute of Technology*  
Fashion Designer  
Leather and Suede



**Elaine Stone**

*Professor Emeritus, Fashion Institute of Technology*

Fashion Marketing and Merchandising

**Mitchell D. Strauss**

*University of Northern Iowa*

Reenactors

**Pauline Sullivan**

Recycled Textiles

**Barbara Sumberg**

*Curator of Textiles and Costume, Museum of International Folk Art, Santa Fe, N.M.*

Traditional Dress

**Anne Hartley Sutherland**

*Georgia State University*

Roma and Gypsy

**Lou Taylor**

*Professor of dress and textile history, University of Brighton*

Art Nouveau and Art Deco  
Cunnington, C. Willett and  
Phillis

Fashion, Historical Studies of  
Mourning Dress

**Edward Tenner**

*Princeton University*

Pins  
Needles  
Safety Pins  
Sewing Machine

**Howard Thomas**

*Auburn University*

Knitting Machinery  
Weave, Double  
Weave, Pile  
Weave, Slack Tension

**Stefano Tonchi**

Military Style

**Susan J. Torntore**

*Iowa State University, Ames, Iowa*

Breeches  
Brooches and Pins  
Doublet  
Hosiery, Men's  
Necklaces and Pendants

**Phyllis Tortora**

*Author of Understanding Textiles, The Fairchild Encyclopedia of Fashion Accessories, and The Fairchild's Dictionary of Textiles*

Ancient World: History of  
Dress  
Europe and America, History of  
Dress (400-1900 C.E.)  
Fibers  
Toga

**Jane Trapnell**

Adrian

**Julianne Trautmann**

Bracelets  
Hair Accessories

**Efrat Tseëlon**

*University College, Dublin*

Baudrillard, Jean

**Marketa Uhlířová**

*Associate Lecturer and Research Assistant at Central Saint Martins College of Art and Design*

Galliano, John

**Laurel Thatcher Ulrich**

Homespun

**Jonathan Walford**

*Artistic director of Kirksbaw Productions*

Sandals  
Shoemaking  
Shoes  
Shoes, Women's

**Myra Walker**

*University of North Texas*

Cardin, Pierre  
Miniskirt

**Susan Ward**

*Research Fellow, Department of Textile and Fashion Arts, Museum of Fine Arts, Boston*

A-Line Dress  
Chemise Dress  
Earrings  
Eyeglasses  
Sunglasses  
Swimwear

**Patricia Campbell Warner**

*University of Massachusetts, Amherst*

Golf Clothing  
Shirtwaist  
Sportswear

**Susan M. Watkins**

*Professor Emeritus, Cornell University*

Fashion, Health, and Disease  
Protective Clothing  
Space Suit

**Judith Watt**

Clark, Ossie  
Muffs

**Melinda Watt**

*Metropolitan Museum of Art*

Beene, Geoffrey  
Buttons  
Extreme Fashions  
Hawes, Elizabeth  
Weaving Machinery

**Tiffany Webber-Hanchett**

*Museum of Fine Arts, Boston*

Bikini  
Fashion Television  
Fogarty, Anne  
Hilfiger, Tommy  
Madonna

**Linda M. Welters**

*Professor, Textiles, Fashion Merchandising and Design, University of Rhode Island*

Folk Dress, Eastern Europe  
Folk Dress, Western Europe  
Folklore Look

**Lauren D. Whitley**

*Museum of Fine Arts, Boston*

Demorest, Mme.  
Galanos, James  
Kamali, Norma  
Levi Strauss & Co.  
Tanning of Leather  
Wearable Art

**Clare Wilcox**

*Senior Curator, modern fashion, Victoria & Albert Museum, London*

Alaïa, Azzadine  
Comme des Garçons

**Gloria M. Williams**  
*University of Minnesota*  
 Labor Unions  
 Textile Workers

**Robyne Williams**  
*North Dakota State University*  
 Dyeing, Resist  
 Dyes, Chemical and Synthetic  
 Flocking  
 Fulling  
 Glazing

**Elizabeth Wilson**  
*Professor Emeritus, London*  
*Metropolitan University*  
 Biba  
 Bohemian Dress

**Eric Wilson**  
*Women's Wear Daily*  
 Fashion Industry

**Laurel E. Wilson**  
*University of Missouri-Columbia*  
 Cowboy Clothing

**Verity Wilson**  
*Asian Department, Victoria & Albert*  
*Museum, London, U.K.*  
 Qipao  
 Mao Suit

**Geitel Winakor**  
*Mary B. Welch Distinguished Professor*  
*in Family and Consumer Sciences, Iowa*  
*State University*  
 Economics and Clothing

**Theresa M. Winge**  
*University of Minnesota*  
 Branding  
 Implants  
 Modern Primitives  
 Occult Dress  
 Scarification  
 Tattoos

**Norma H. Wolff**  
*Department of Anthropology, Iowa*  
*State University*  
 Adire  
 Caftan  
 Dashiki

**Gundula Wolter**  
 Trousers

**Rachel Worth**  
 Marks & Spencer

**Ann Wright-Parsons**  
*Director, Anthropology Museum*  
 Textiles, Southeast Asian  
 Islands

**Kohle Yohannan**  
 McCardell, Claire  
 Valentina

**Steve Zdatny**  
*Associate Professor of History, West*  
*Virginia University*  
 Hairdressers  
 Hairstyles

**Bhakti Ziek**  
*Cerrillos, N.M.*  
 Loom  
 Weave Types  
 Weaving



# INDEX

---

Bold page numbers (e.g. **1:10–11**) refer to the main entry on the subject. Page numbers in italics refer to illustrations, figures and tables.

## A

- A-Line dresses, *1:35*, **35–36**  
 A Piece of Cloth (A-POC), 2:117, 310, 418, 420  
*Abaca*, 3:314  
*Abaya*, 3:392  
 Abbasid dress, 2:404–405, 3:287  
 Abington, Caroline, 1:6  
 Abrasilacon scarification, 3:144  
 Academic dress, **1:1–2**, 2  
 Academy Awards  
   Head, Edith, 2:191  
   tuxedos, 3:345–346  
 Accessories  
   canes and walking sticks, 1:220  
   Cardin, Pierre, 1:225  
   Central Asia, 1:79  
   Chanel, Gabrielle (Coco), 1:253  
   for cocktail dresses, 1:274–275  
   embroidery of Lesage, 2:351  
   fans, 2:5–8  
   gloves, 2:146–147  
   Gucci, 2:110, 155–156  
   hair, 2:157–160  
   international trade, 2:127  
   lace, 2:325–326  
   Middle Ages, 1:422  
   muffs, 2:427–428  
   1950s fashion, 3:351  
   Pucci, Emilio, 3:65  
   ready-to-wear, 3:84  
   Russian designers, 3:127  
   Saint Laurent, Yves, 3:133  
   scarves, 3:143  
   Schiaparelli, Elsa, 3:146  
   Sub-Saharan African dress, 1:21  
   Vuitton, Louis, 3:408  
   watches, 3:410–411  
   wedding costumes, 3:427  
 Acetate, 3:82–83  
 Achaemenid dress, 2:248  
 Acid dyes, 1:387–388  
 Ackermann, Haider, 1:145  
 Acquisitions and mergers  
   Fairchild Publications, 3:440  
   Gucci, 2:110  
   Lesage company, 2:351  
   pattern makers, 3:26  
   retailers, 2:52  
   Saint Laurent, Yves, 3:133  
 Acrylic and modacrylic fibers, **1:2–3**  
 Active protection, 3:60  
 Activewear, **1:3–4**, 3:219  
 Activism  
   Afro hairstyle, 1:26–27  
   Moschino, Franco, 2:424  
 Actors and actresses, **1:5–6**  
   *See also* Celebrities; Film and fashion  
 Adams, Stacey, 3:468  
 Adidas  
   sneakers, 3:196  
   sport shoes, 3:215  
   sweatshirts, 3:247  
   Yamamoto's association with, 3:455  
 Adinkra, **1:6–8**, 7, 8, 3:282  
*Adire*, **1:8–10**, 3:281  
 Adler and Adler, 1:232  
 Adot, Laurencio, 2:335  
 Adrian, **1:10–11**  
   American fashion, 2:51  
   Clark, Ossie, influence on, 1:268  
   costume design, 2:222  
   Crawford, Joan, fashions for, 2:46  
   film and fashion, 2:82, 83  
   “Letty Lynton” dress, 3:323  
 Advertising, **2:27–29**  
   Arrow Man, 3:275  
   Barneys New York, 2:49  
   Bourdin, Guy, 1:177–178  
   brassieres, *1:189*, *190*  
   celebrity, 1:239  
   children's shoes, *3:170*  
   corsets, *1:291*  
   cosmetics, 1:298, 299  
   department stores, 1:363  
   designer jeans, 2:274, 306  
   Dolce and Gabbana, *1:371*  
   fashion designers, 2:36  
   fashion illustrations, 2:66  
   fashion magazines, 2:56  
   Fendi, 2:77, 77  
   Gap campaign, 2:372  
   Gucci, 2:110  
   Hilfiger, Tommy, 2:213, 214  
   laundry soap, *2:337*, *338*, 339–340  
   Lauren, Ralph, 2:341  
   Levi Strauss, 2:352  
   Marks & Spencer, 2:386  
   Meisel, Steven, 2:401–402  
   men's underwear, 2:290  
   Missoni, 2:416  
   nail polish, *2:438*, 439  
   ready-to-wear, 3:88  
   shirtwaists, *3:163*  
   Solco hair products, *2:162*  
   sunglasses, 3:241  
   sweatshirts, 3:246  
   swimwear, 3:252–253  
   t-shirts, 3:341  
   underwear, *2:306*  
   women's shoes, *3:176*  
   Worth, Charles Frederick, 3:447–448  
   *See also* Marketing; Public relations  
 Aertex, 3:279  
 Aesthetic dress, **1:11–14**, *13*  
   artistic dress, 3:412  
   attacks on fashion, 2:15–16  
   dandyism, 1:343–344  
   dress reform, 1:382  
   historical revivals, 2:220  
   subcultures, 3:233  
   Wilde, Oscar, 1:426, 3:432  
 Afghan stitch, 1:318  
 Afghanistan  
   burqas, 1:202–203, 2:133, 253  
   veiling, 2:408, 3:392, 393  
 Africa  
   beads, 1:135  
   bogolan, 1:169–170  
   British colonialism, 1:278  
   cache-sexe, 1:211



- Africa (*continued*)  
 carnival dress, 1:230–231  
 colonialism and composite dress, 1:279  
 cosmetics, 1:294–295  
 ecclesiastical dress, 1:397  
 ethnic dress, 1:415–416  
 hair braiding, 2:158–159  
 kanga, 2:297–296  
 kente, 2:299–300  
 Kouyaté, Lamine, 3:452  
*sapeurs*, 3:137  
 secondhand clothes, 3:152–153, 154  
 textiles, 3:279–283  
 tie-dyeing, 3:327–328  
*See also* East Africa; North African dress; Sub-Saharan African dress; West Africa; Specific countries
- African American dress, **1:14–16**  
 dashikis, 1:346–347  
 ethnic textiles, 3:99  
 hip-hop, 2:214–218  
 music and fashion, 2:432–433  
 women's hats, 2:185  
 zoot suits, 3:466–468
- African Americans  
 Afros, 1:25–28  
 barbers, 1:119  
 beauty ideals, 2:130  
 cosmetics, 1:297, 299  
 debutantes, 1:349  
 employment by Madame Demorest, 1:359  
 fashion models, 2:59, 65, 401  
 kente and cultural identity, 2:300  
 models, 3:337  
 nail art, 2:439  
 subcultures, 3:235  
 teenage fashion, 3:276  
 wigs, 3:431
- African fashion  
 Seydou, Chris, 3:159–160  
 Sy, Oumou, 3:255–257
- African Independent Churches, 1:397
- African textiles, 3:256, **279–283**
- Afro hairstyles, 1:16, **25–28**, 26
- Afrocentric fashion, **1:28–30**, 29
- After Words collection, 1:248
- Afterimages, 1:282
- Agbada*, **1:30–32**
- Agent Provocateur, 2:357
- Agha, M. F., 3:405
- Agins, Teri, 2:118
- Aglets, 3:195
- Agnès, 2:184, 412
- AIDS  
 Ellis, Perry, 1:407  
 Halston, 2:168  
 red ribbons, 3:108
- Ailey, Alvin, 1:339
- Ainu textiles, 3:302
- Air France, 1:110
- Air jet looms, 3:424
- Air jet spinning, 3:456
- Airline pilots, 3:369
- Airline uniforms, 3:369, 372
- Airplane dress, 2:206
- Akker, Koos van den, 1:64
- Alaïa, Azzedine, **1:32–33**  
 fashion photography and, 2:65  
 leather, 2:345  
 little black dress, 2:360  
 Madonna and, 2:372  
 1980s fashion, 3:352  
 retro style, 3:103  
 Vionnet, Madeleine, influence of, 3:404
- Alaska, 2:243, 246–247
- Albanian folk dress, 2:94, 97
- Albers, Anni, 3:413
- Albert Parent et Cie, 1:208
- Albini, Walter, **1:33–35**
- Aleksei, Mikhailovich, 3:123
- d'Alençon, Emilienne, 1:355
- Alexander, Hélène, 2:60
- Alexander, Karen, 2:65
- Alexander, William, 2:17
- Alexandre, 2:161
- Algeria, 2:212
- Allen, Marit, 3:104
- Aloha shirts. *See* Hawaiian shirts
- Alpaca, 1:36, 36–37
- Alpha Phi Alpha fraternity debutante ball, 1:349
- Amazon  
 feathers, 2:74  
 history of dress, 1:45–46
- American Craft Museum, 3:414
- American dress, **1:418–427**  
 adolescents, 2:131  
 aesthetic dress, 1:14  
 African American influence on, 1:16  
 aprons, 1:65–66  
 beards and mustaches, 1:137  
 Brooks Brothers, 1:197–199  
 Council of Fashion Designers of America (CFDA), 3:58  
 Dahl-Wolfe photography, 1:333–334  
 debutante dress, 1:348–349  
 dress shirts, 1:383  
 Empire style, 1:410  
 fashion industry, 2:51–52  
 fashion photography, 2:64  
 garment factories, 2:51  
 Italian fashion, influence on, 2:254  
 jeans, 2:273–275  
 Nehru jackets, 2:451  
 plaid, 3:39–40  
 press coverage, 2:52–54  
 punk, 3:66–67  
 recognition of designers, 2:36  
 school uniforms, 3:375–376  
 Seventh Avenue, 3:155–157  
 sportswear, 3:221  
 subcultures, 3:234  
 t-shirts, 3:342  
 teenage fashion, 3:275–276  
 traditional, 3:332  
 underwear, 3:360–361  
 window displays, 3:435  
 working-class dress, 3:445  
*See also* Central American dress; United States; Specific designers
- American Fabrics* (magazine), 2:274
- American folk dance costumes, 1:337
- American Look  
 Kennedy, Jacqueline, 2:86  
 McCardell, Claire, 2:36, 396–398, 3:20  
 sportswear, 3:221
- American Viscose Corporation, 3:82
- Amies, Hardy, **1:49–51**  
 fashion by, 1:49  
 London fashion, 2:361  
 Savile Row, 3:143  
 tweeds, 3:347
- Amish dress, 3:96, 98, 99, 97
- Amish quilts, 3:75
- Anabaptist groups, 3:98
- Anaste, Charles, 2:49
- Ancien régime, 1:151–152
- Ancient world, **1:51–59**  
 Andean textiles, 3:283  
 armor, 1:69  
 beads, 1:134  
 boots, 1:173  
 bracelets, 1:183–184  
 Chinese dress, 1:261  
 Chinese silk, 3:292–294  
 cotton, 1:306  
 earrings, 1:391  
 fibulae, 1:196  
 hairdressers, 2:160  
 hairstyles, 2:161–162  
 handbags, 2:169  
 headdresses, 2:194  
 helmets, 2:195–196  
 jewelry, 2:277, 278  
 laundry, 2:337  
 lipstick, 2:357  
 manicuring, 2:437  
 masks, 2:388  
 outerwear, 3:7  
 pins, 3:129  
 sandals, 3:135–136  
 spinning, 3:209, 211–212  
 tanning, 3:264–265  
 tapestries, 3:266  
 tattoos, 3:268–269  
 women's footwear, 3:173  
 women's headwear, 2:181  
*See also* Byzantine Empire; Egypt, ancient; Greece, ancient; Rome, ancient
- Andalusian dress, 2:100, *101*, 3:206
- Andean dress, 1:46, 48
- Andean textiles, **3:283–286**, 307
- Anderson, Richard, 1:385
- Andreianova, Viktoriia, 3:127
- Andress, Ursula, 1:156
- Androgyny  
 Gaultier, Jean-Paul, 2:128

- Androgyny (*continued*)  
 hair bobbing, 2:164  
 Lang, Helmut, 2:329–330  
 shoes, 3:172  
 tailored suits, 3:260  
 Twiggy, 3:355  
 unisex clothing, 3:383  
 Yamamoto, Yohji, 3:454, 455  
 Youthquake fashion, 3:461
- Androver, Miguel  
 burberry, 1:202  
 Oriental belly-dance costumes,  
 influence of, 1:338
- Angell, Caroline, 2:429
- Anglican Church, 1:396–397
- Angola, 2:391–392
- Angora, **1:59**, 2:421
- Animal prints, **1:59–60**, 60, 3:389
- Animal rights  
 anti-fur campaign, 2:116  
 fur alternatives, 1:60  
 leather use, 2:345  
 1980s fashion, 3:353
- Anne, Princess, 1:412, 2:426, 3:105
- Annie Hall* (film), 2:84–85
- Anthropology of secondhand clothes,  
 3:151–153
- Anti-aging cosmetics, 1:299–300
- Anti-fashion, 2:218, 3:413
- Anti-Semitism  
 Beaton, Cecil, 1:139  
 Nazi dress policy, 2:8–9
- Antifur campaigns, 2:116
- Antimicrobial finishes, 3:33
- Antinoé, 3:297, 299
- Antoine, 2:161
- Antropometry, 1:331
- Antwerp, Belgium, 1:142–340
- Ao dai*, **1:60–62**, 61, 84
- Apaches  
 masks, 2:390  
 rites of passage costumes, 1:241–242
- Apollo space program, 3:201, 202
- Appearance, **1:62–64**  
 identity and, 2:34, 35  
 theory of fashion, 2:23–24
- Applied forces, 2:72
- Appliqué, **1:64**, 3:75
- Apprenticeships  
 cutters, 1:331  
 Fontana sisters, 2:104  
 seamstresses, 3:150  
 tailors, 3:262
- Aprons, **1:64–66**, 2:284, 3:311
- Aquascutum, 3:80
- Arab dress  
*djellaba*, 1:369–370  
*bijab*, 2:209–213  
 veils, 3:392–393  
*See also* Islamic dress; Middle Eastern  
 dress
- Arafat, Yasir, 2:293
- Aragon, Louis, 3:146
- Aran sweaters, 2:309
- Arbeid, Murray, 1:363
- Arbeitsgemeinschaft deutsch-arischer  
 Fabrikanten der Bekleidungsindustrie*,  
 2:9
- Arbus, Diane, 2:64
- The Arcades Project* (Benjamin), 1:147–148
- Archaeology  
 Central Asian textiles, 3:289  
 Chinese textiles, 3:292–294  
 Gayet, Albert, 3:297–298, 299  
 Peruvian tombs, 3:283  
 Southeast Asian textiles, 3:316  
 spinning, 3:208  
*See also* Ancient world
- Architecture  
 department stores, 1:362–363  
 fashion and, 1:247–248, 3:458
- Arden, B., 2:103
- Arden, Elizabeth, 1:296  
 Fashion Group, 3:57  
 James, Charles and, 2:259  
 lipstick, 2:358  
 salon, 1:297
- Argentine dress, 2:333–334
- Arickx, Filip, 1:145
- Aristocratic dress. *See* Royal and  
 aristocratic dress
- Arkwright, Richard, 3:210–211
- Armani, Giorgio, **1:66–68**, 67  
*ao dai* style, 1:62  
 Asian influence, 3:15  
 business suits, 3:238  
 costume design, 2:83, 222  
 eyewear, 1:434  
 grunge, 2:154  
 Italian fashion, 2:255  
 leather, 2:345  
 masculinized fashions for women,  
 2:133  
 men and fashion, 2:13  
 military style, 2:410  
 1980s fashion, 3:353  
 1990s fashion, 3:353  
 sportswear, 3:20  
 sweaters, 3:245  
 t-shirts, 3:343  
 tailoring, 3:263  
 trench coats, 3:80  
 tuxedos, 3:345
- Armor, **1:68–71**  
 ceremonial functions, 1:244  
 chain mail, 3:58–59  
 helmets and, 2:197  
 military uniforms, 3:366, 368
- Armstrong, Henry, 1:182
- Armstrong, Josephine, 3:23
- Army, U.S.  
 berets, 1:150  
 helmets, 2:197  
 t-shirts, 3:341
- Arnault, Bernard  
 haute couture, 2:188
- Lacroix, Christian and, 2:327
- Arnold, Janet, 2:19
- Arpege (perfume), 3:36
- Arrow Man advertisements, 3:275
- Arsacid dress, 2:249
- Art  
 nudity and, 2:460–461  
 quilts as, 3:75
- Art and fashion, **1:71–76**  
 buttons, 1:206–207, 209  
 Capucci, Roberto, 1:222  
 Delaunay, Sonia, 1:352  
 fashion photography, 2:62  
 Fortuny, Mariano, 2:113–114  
 Gernreich, Rudi, 2:137  
 handwoven textiles, 2:174, 175  
 hats, 2:413  
 Italian futurist fashion, 2:118–119  
 jewelry, 2:283  
 kimonos, 2:305  
 knitting, 2:310  
 lace-making, 2:326  
 Lacroix, Christian, 2:328  
 Paquin, Jeanne, 3:17–18  
 the person as art, 1:343  
 Poiret, Paul, 3:45  
 Pre-Raphaelites, 1:426  
 rings, 3:110  
 Saint Laurent, Yves, 3:132  
 scarves, 3:143  
 Southeast Asian textiles, 3:317–318  
 t-shirts, 3:343  
 wearable art, 2:305, 3:411–414  
 window displays, 3:434–435  
 Yeohlee, 3:458
- Art deco, **1:76–78**  
 Barbier, Georges, 1:123–124  
 earrings, 1:393  
 Iribe, Paul, 2:250  
 1920s fashion, 3:349  
 Patou's salon, 3:22  
 Poiret, Paul, 3:348
- Art galleries, 1:365
- Art nouveau, **1:76–78**, 326
- The Art of Beauty* (Haweis), 1:12
- Art textiles, 3: 302
- Artisans  
 globalization, 2:145  
 Southeast Asian weavers, 3:317–318  
 weavers, 2:174
- Artisan's Gallery, 3:414
- Artists. *See* Painters
- Arts and Crafts movement  
 artistic dress, 3:412  
 bohemian dress, 1:172  
 gothic influence, 2:219  
 mingei movement's relationship to,  
 2:271
- Artwork, 2:49–50, 3:245
- Asante  
 adinkra cloth, 1:6–8  
 kente, 2:299–300  
 wealth and dress, 1:24  
 weaving, 3:280

- Asboth, J., 3:277  
 Ascots, 2:446  
 Ash, Mary Kay, 1:299  
 Ashley, Laura, 2:310  
 Asia  
   ethnic dress, 1:415  
   fashion education, 2:42–43  
   ikat, 2:231–233  
   umbrellas and parasols, 3:357  
   *See also* Central Asian dress; East Asian dress; South Asian dress; Southeast Asian dress  
 ASICS, 3:196, 215  
*Aso oke*, 3:280  
 Association of Canadian Couturiers, 2:188  
 Astaire, Fred, 1:340  
 Astronauts' helmets, 2:198  
 Asuka period, 2:266  
 Asymmetrical cut, 1:353–354  
 Atelier of Fashion, 1:286  
 Atelier Simultané, 1:352  
 Atget, Eugène, 2:379, 3:434  
 Atlas, Charles, 1:166  
 Attacks on fashion, **2:13–16**  
 Auburn, Rachel, 2:432  
 Audemars, Georges, 3:82  
 Austin, Bunny, 3:277, 278  
 Australian dress and fashion, **1:101–104**, 103  
   Driza-Bone, 3:3  
   fashion education, 2:42  
   subcultures, 3:234  
 Austria  
   folk dress, 2:99, 99–100, 102  
   postman, 3:370  
   royal and aristocratic dress, 3:116–118  
 Autant Lara, Claude, 1:2  
 Automated weaving, 3:424–425  
 Automatic washing machines, 2:339–340  
 Avant-garde  
   art and fashion, 1:73–74  
   artistic dress, 1:5  
   Belgian fashion, 1:142–145  
   fashion plates, 2:67  
   Hugo Boss, 2:230  
   Kawakubo, Rei, 3:20  
   Miyake, Issey, 2:417–420  
   modern-dance, 1:339  
   music and fashion, 2:433  
   1980s fashion, 3:352  
   Rabanne, Paco, 3:78  
   Rhodes, Zandra, 3:104–105  
   Rykiel, Sonia, 3:128  
   unisex clothing, 3:383–384  
   Viktor & Rolf, 3:398  
   Yamamoto, Yohji, 3:20  
 Avedon, Richard, **1:104–105**, 105  
   fashion editors and, 2:40  
   Munkacsy, Martin, influence of, 2:64  
   space age styles, 3:199  
   style of, 2:64, 65  
   Twiggy, photographing of, 3:355  
   Versace, Donatella and, 3:396  
   Vreeland, Diana and, 3:407  
 Aviation coats, 3:80  
 Aviator sunglasses, 3:241  
 Avon, 1:299  
 Awls, 3:166  
 Ayrshire whitework, 1:408  
 Ayton, Sylvia, 3:104  
 Ayuthaya period, 1:99  
 Azagury, Jacques, 1:364  
 Azoic dyes, 1:388  
 Aztec headdresses, 2:194
- B**  
 B-boys, 2:215–216  
 Baby boomers  
   street style, 3:226  
   teenage fashion, 3:275–276  
 Baby-doll pajamas, 3:13  
 Babylonia, 3:84  
 Bachelder, John, 3:157  
 Backpacks, 2:172  
 Backstrap looms, 2:174  
 Backstreet Boys, 1:336  
 Bactrian camels, 1:218  
 Badu, Erykah, 1:27  
 Baguette handbag, 2:78  
 Bahri army, 2:405  
 Bailey, Christopher, 1:202  
 Bailey, David, 2:64, 3:355  
 Baining masks, 2:389  
 Baiul, Oksana, 3:187  
 Bakelite buttons, 1:209  
 Baker, Josephine  
   dance and fashion, 1:334, 335, 339  
   demimonde, influence of the, 1:357  
   as fashion icon, 2:46  
 Bakst, Leon  
   costume design, 3:5, 125–126  
   Poiret, Paul and, 3:45  
 Balanchine, George, 1:339  
 Balenciaga, Cristóbal, **1:107–112**  
   A-Line, 1:35  
   Alaïa, Azzedine and, 1:33  
   chemise dress, 1:255  
   Courrèges, André and, 1:309  
   De La Renta, Oscar and, 1:350  
   embroidery of Lesage, 2:350  
   fashion shows, 2:53  
   folklore look, 2:103  
   Galanos, James and, 2:123  
   Givenchy, Hubert de and, 2:141  
   homosexuality, 2:32  
   little black dress, 2:359  
   1950s fashion, 3:350  
   Rabanne, Paco and, 3:77  
   rubber wear, 3:121  
   signature design, 1:108  
   simplicity, 3:454  
   Spanish fashion, 3:206  
   Steele, Lawrence, influence on, 3:222  
   tailored suits, 3:261  
   trends, 2:184  
 Balestra, Renato, 2:105  
 Balfour, Emma, 2:203  
 Balkan countries  
   folk dress, 2:96–97  
 Ball, Lucille, 2:395  
 Ball dress, **1:112–114**, 113  
   dance costumes, 1:339  
   De La Renta, Oscar, 1:351  
   debutantes, 1:348–349  
   etiquette, 1:335  
   masked balls, 2:393–394  
   tango dress, 1:334–335  
   waltzes, 1:334  
   *See also* Fancy dress  
 Balla, Giacomo  
   art and fashion, 1:72  
   Italian futurism, 2:118  
   wearable art, 3:413  
 Ballard, Bettina, 2:40  
 Ballet costumes, **1:114–116**  
   leotards, 2:349  
   men's, 1:340  
   pointe shoes, 3:43  
   sheerness, 3:45  
   *See also* Dance costumes  
 Les Ballets Russes, 3:43, 45  
 Balmain, Pierre, 1:116, **116–117**  
 Dior, Christian and, 1:366  
   embroidery of Lesage, 2:350  
   haute couture, 2:187  
   1950s fashion, 3:350  
   Praline and, 2:69  
   t-shirts, 3:343  
 Balmoral berets, 1:150  
 Balmoral boots, 1:174, 3:172  
 Balmoral Castle, 2:301  
 Balsan, Étienne, 1:249  
 Baltic countries, 2:93–94  
 Balzac, Honoré de, **1:117–119**, 118, 356  
 Bancroft, 1:102  
 Bandeaux, 3:278  
*Bangdian*, 3:311  
 Bangladesh  
   dress, 1:91, 91–92  
   textiles, 3:308  
 Bangle bracelets, 1:183  
 Banks, Jeffrey, 2:307  
 Banks, Joseph, 2:367, 368  
 Banton, Travis, 2:46  
 Barbas, Raymond, 3:24  
 Barbers, **1:119–121**, 120, 2:160  
 Barbery D'Aureville, Jules, 1:341, 342, 343  
 Barbie, **1:121–123**, 122  
 Barbier, Georges, **1:123–125**  
   evening dress, 1:429  
   fashion illustrations, 2:49  
   fashion plates, 2:66, 67  
   Poiret fashion, 3:45  
 Barbours, 3:3  
 Barettes, 2:158



- Bark cloth, *1:96, 125–126, 126, 3:313*
- Barnes, David, 2:429
- Barneys New York, 2:49
- Baroque period  
ballet costumes, 1:114  
European and American dress, 1:423
- Bartenev, Andrei, 3:127
- Barthes, Roland, **1:127–129**
- Barthet, Jean, 2:413
- Barzini, Benedetta, 2:401
- Baseball uniforms, 2:181, 3:218, 381
- Basi, Armand, 2:432
- Basic dyes, 1:388
- Basket weave, 3:417
- Basketball uniforms, 3:381–382
- Basque berets, 1:149
- Basset, Anne, 3:120
- Bathhouses, 3:463
- Bathing beauties, 3:250
- Batik, **1:129–130, 130**  
African textiles, 3:282  
Japanese textiles, 3:301  
Java, 2:294, 295  
Orientalism, 3:5
- Batiste. *See* Cambric, Batiste, and Lawn
- Batteries, 3:274, 411
- Batters, Elmer, 3:224
- Battle of Culloden, 3:267
- Baudelaire, Charles, **1:130–132, 131, 343, 2:66**
- Baudrillard, Jean, **1:132–134, 133, 2:16**
- Baum, L. Frank, 3:434
- Bausch, Pina, 1:339
- Bausch & Lomb, 3:240
- Bavarian dress  
diplomatic uniforms, 3:362–363  
folk dress, 2:99
- Bazaar (boutique), 1:180, 2:415, 3:72, 460
- Beachwear  
beach pajamas, 3:14  
sandals, 3:136  
*See also* Swimwear
- Beads, **1:134–136**  
African American dress, 1:14  
hair accentuation, 2:158  
Native Americans, 1:409  
Sub-Saharan Africa, 1:22  
trimmings, 3:339
- Bean, Alan, 3:201
- Bean, L. L., 3:214, 215
- Beards and mustaches, **1:136–137**  
Egypt, ancient, 1:54–55  
India, 2:237  
Sixteenth century, 2:162
- Beardsley, Aubrey, prints of, *1:76*
- Beatles  
boots, 2:205  
collarless jackets, 2:450  
1960s fashion, 3:351
- Beatniks, 2:359
- Beaton, Cecil, **1:137–139, 138**  
caricature, 1:229  
dandyism, 1:344
- documentary style, 2:64  
fashion editors and, 2:40  
James' designs, drawings of, 2:259  
*My Fair Lady* costumes, 1:340  
surrealism, 2:64  
Twiggy, photographing of, 3:355  
Windsor, Duchess of, 3:438
- Beau Brummell* (Fitch), 1:200
- Beaumont, Étienne de, 1:251
- Beauty  
African Americans and beauty norms, 1:25  
athletic women, 2:133  
Barbie dolls, 1:122  
Baudelaire on, 1:132  
cosmetics industry, 1:296–300  
cultural aspects, 2:130  
Beauty pageants, *1:263, 3:250*
- Beauty surgeons, 3:40
- Beaver fur, 2:76, 115
- Becca, 2:178
- Beckford, Ruth, 1:25
- Beckham, David, 1:239–240
- Bedding  
bark cloth, 1:125–126  
quilted, 3:74–75
- Bedin, Albert Godde, 2:67
- Beecroft, Vanessa, 3:222, 335
- Beehive hairstyle, 2:165
- Beene, Geoffrey, **1:139–142, 141**  
embroidery of Lesage, 2:350  
leather, 2:345  
shirtwaists, 3:164  
sportswear, 3:221  
stage *vs.* runway shows, 2:53  
*Women's Wear Daily* review, 3:440
- Beerbohm, Max, 1:228
- Before minus now collection, 1:248
- Beige, 3:22
- Beirendonck, Walter van, 2:118
- Beker, Jeanne, 2:70–71
- Belarus, 2:94
- Belgian fashion, **1:142–146, 144, 145**  
1990s, 3:353  
Paris fashion system, 2:265, 3:20  
unisex clothing, 3:384  
*See also* Specific designers
- Bell, Clive, 1:333
- Bell, John, 2:66
- Bell and Khan, 2:432
- Bellanger, Marguerite, 1:355
- Belle Époque, *1:355*  
demimonde, 1:355  
Dior, Christian, influence on, 1:367  
jewelry, 2:283  
Proust, Marcel, 3:61  
World War II, 2:452
- Belly-dance costumes, 1:338–339
- Belts and buckles, **1:146–147, 3:172, 174–175**
- Benedict, Aaron, 1:208
- Benetton  
advertising, 2:29
- knitwear, 2:310  
sport shirts, 3:213  
sweaters, 3:245
- Benini, Giulia, 1:355
- Benito, Eduardo Garcia, 2:49
- Benjamin, Walter, **1:147–149**  
courtesans, 1:356  
dandyism, 1:341  
modernity, 2:387
- Bennett, Michael, 1:340
- Benois, Alexander, 3:126
- Benzine, 1:384
- Bérard, Christian  
Cardin, Pierre and, 1:223  
fashion illustration, 2:49  
fashion plates, 2:67  
Hoyningen-Huene, George and, 2:228  
Saint Laurent, Yves, influence on, 3:130  
Schiaparelli, Elsa and, 3:146
- Berardi, Antonio, 3:105
- Berdaches, 1:319
- Berets, *1:149, 149–151, 150, 2:181*
- Bergdorf Goodman, 2:185
- Bergé, Pierre, 3:130–133
- Berger, John, 2:460, 461
- Bergère, Eric, 2:202
- Bergery, Bettina, 3:147
- Berlin iron, 2:282
- Bermuda shorts, 2:150
- Bernhardt, Sarah, 1:6, 3:44
- Bertelli, Patrizio, 3:221
- Berthelot, Gaston, 1:254
- Bertin, Rose, **1:151–152, 2:183, 411**
- Bespoke tailoring, 3:261
- Best dressed lists, **1:152–153, 3:51**
- Bettina, 2:69, 141
- B'hoys, 3:274
- Bhutan, 1:90–91, 3:311
- Biagiotti, Laura, 2:255
- Bianchini and Ferrier, 1:216
- Bias cut, 3:402–404
- Biba, *1:153, 153–154*  
art nouveau, 1:77  
boutique shopping, 1:180–181  
Youthquake fashion, 3:459, 461, 462
- Bicycle clothing, **1:154–155, 155**  
bloomers, 1:163  
helmets, 2:197–198  
women's dress, 1:426
- BID (Business Improvement Center), 3:156
- Biga Bag, 2:78
- Biguine, Jean-Claude, 2:161
- Bikinis, **1:155–157, 3:253, 254, 350**
- Bikkembergs, Dirk, 1:144, 2:265, 3:353
- Bilibin, Ivan, 3:125
- Billabong, 1:103
- Bingata*, 3:301
- Bird populations, 2:74–75
- Birkin bags, 2:171, 173, 201–202
- Birtwell, Celia, 1:268, 269
- Bis, Dorothee, 3:128

- Bismarck, Mona, 1:110  
 Bizcarrondo, Nicolas, 1:109  
 Black  
   Abbasid dynastic color, 2:404–405  
   bohemian dress, 1:172  
   Chanel, Gabrielle (Coco), use by, 1:250–251  
   De la Renta, Oscar, 1:351  
   dyes, 1:389  
   formal wear, 2:110–112  
   fringe, 2:96  
   goths, 2:151  
   legal and judicial costume, 2:346–348  
   little black dress, 2:358–360  
   mourning dress, 2:425–426  
   punk, 3:68  
   Spanish dress, 3:204, 205  
   symbolism, 3:119  
   Yamamoto, Yohji, 3:454  
 Black, Misha, 3:435  
 Black-and-white photography, 3:31  
 Black Death, 1:401  
 Black is beautiful, 1:26, 30  
 Black market, 1:288–289  
 Black Panthers, 1:30  
 Black Tai, 1:99  
 Black tie, 2:110–112, 2:111  
 Blackwell, Betsy, 2:40  
 Blackwell, Richard, 1:152  
 Blackwork embroidery, 1:408  
 Blackwork tattoos, 2:420–421  
 Blahnik, Manolo, 1:157, 157–159  
   ballerina fashion shoes, 3:43  
   Ellis, Perry, collaboration with, 1:407  
   high heels, 2:205  
   “Sex and the City” (television show), 1:240  
 Blair, Alastair, 3:149  
 Blake, Lyman Reed, 3:195  
 Blass, Bill, 1:159, 159–160  
   Bush, Barbara, designs for, 2:86  
   celebrity, 2:52  
   embroidery of Lesage, 2:350  
   leather, 2:345  
   perfume, 3:36  
   Saint Laurent, copying style of, 3:103–104  
   shirtwaists, 3:164  
   sportswear, 3:221  
 Blatt, Anny, 2:386  
 Blazers, 1:160–161, 3:219, 219  
 Blended yarns, 3:458  
*Bliants*, 1:420  
 Block patterns, 1:330–331  
 Block printing  
   African textiles, 3:282  
   Central Asian textiles, 3:291  
   Fortuny, Mariano, 2:114  
   Islamic textiles, 3:303  
 Blonde Ambition tour, 2:430, 3:419  
 Blonde hair, 2:162  
 Bloomer, Amelia, 1:161, 381–382, 3:340  
 Bloomer costume, 1:161–163, 162, 381–382, 3:13–14  
 Bloomingdales, 2:417  
 Blouses, 1:163–164, 2:141  
 Blow, Isabella, 2:399, 3:334–335  
 Blucher boots, 1:174  
 Blue-collar dress, 1:377–378  
 Blue formal wear, 3:438  
 Blue jeans. *See* Jeans  
 Bluebonnets, 1:150  
 Blumarine, 3:43  
 Blumenfeld, Erwin, 2:64, 379  
 Boateng, Ozwald, 1:344, 3:143, 263  
 Boater hats, 2:180, 180  
 Bobbin lace, 2:323, 325  
 Bobby hats, 2:197  
 Bobby pins, 2:157–158  
 Bobby soxers, 2:430, 3:275  
 Bobs, hair, 2:157–158, 164, 165  
 Bodgies and widgeys, 3:234  
 Body  
   appearance and, 1:63–64  
   artistic concept of, 1:73  
   color and, 1:282  
   costume and dress, 1:272  
   cultural ideals, 2:130  
 Body adornment. *See* Cosmetics  
 Body exposure regulations, 3:48–49  
 Body hair removal, 2:237  
 Body Map, 1:319  
 Body meters, 3:263  
 Body modification  
   appearance and, 1:63  
   branding, 1:186–187  
   footbinding, 1:431, 2:106–109  
   implants, 2:233–235  
   modern primitives, 2:420–421  
   neck elongation, 1:431  
   negative connotation of, 1:430  
   piercing, 1:166–169, 393–394, 431  
   plastic and cosmetic surgery, 3:40  
   scarification, 3:144–145  
   Sub-Saharan Africa, 1:21–22  
 Body painting, 1:242  
 Body piercing, 1:166–169, 393–394, 431  
 Body scanning, 1:331, 2:37, 57–58  
 Body Shop, 1:299  
 Bodybuilding and sculpting, 1:165–166  
 Bodyguards, 1:70  
 Bodysuits. *See* Leotards  
 Bogatyrev, Petr, 2:95  
 Bogolan, 1:169–170, 3:159, 281  
 Bohan, Marc  
   Delaunay, Sonia, influence of, 1:352  
   Dior, House of, 1:368  
 Bohemian dress, 1:170–173  
   dandyism, 1:343, 345  
   subcultures, 3:232–233  
   vintage fashion, 3:399  
 Bohus Stickning collective, 2:310  
 Boilly, Louis-Léopold, 1:228  
 Boissonas et Taponnier, 2:62  
 Bold Look, 2:447  
 Bolide bag, 2:171  
 Bolivian *chullos*, 2:308, 309–310  
 Bolsheviks, 1:286–288  
 Bolton, Matthew, 1:207–208  
*Bombay Dreams* (musical), 1:340  
 Bon Marché, 1:361  
 Bond, James, 3:345  
 Bonding of nonwoven textiles, 2:456  
 Boniface, Ennemon, 2:459  
 Bonnets, 2:411–412  
 Bonwit Teller, 2:306  
 Bonwyn, 1:102  
 Boots, 1:173–175, 3:168  
   Courrèges, André, 1:309, 311, 2:415, 3:400  
   cowboy, 1:314, 315  
   fetish fashion, 2:81  
   Inuit and arctic, 2:245, 246–248  
   women’s, 3:176, 177  
 Borneo, 3:269  
 Bosio, Jean-Francois, 1:228  
 Bosse, Abraham, 2:48  
 Bosso, Renato di, 2:118  
 Boston Museum of Fine Arts, 2:61  
 Botox, 2:233, 234  
 Boubous, 1:175–177, 176  
 Bouché, 2:67  
 Boucheron, La Maison, 1:326  
 Bouclé yarns, 3:458  
 Boulanger, Louise, 1:274  
 Bouquets, 3:427  
 Bourbon, Louise, 2:412  
 Bourdin, Guy, 1:177–179  
   French *Vogue*, 2:65  
   morality and photography, 2:203  
   Paris *Vogue*, 3:20  
 Boussac, Marcel  
   Dior, Christian and, 1:366, 368  
   haute couture, 2:189  
 Boutiques, 1:179–181  
   Bazaar, 2:415, 3:72  
   Biba, 1:77, 153–154  
   Cheap and Chic, 2:423–424  
   display windows, 3:434–436  
   Fath, Jacques, 2:73  
   Fulham Road Clothes Shop, 3:104  
   haute couture, 2:187–188  
   India, 2:240  
   London, 3:354–355  
   Patou, Jean, 3:23  
   retailing, 3:102  
   Rykiel, Sonia, 3:128  
   Youthquake fashions, 3:459–460  
 Bow, Clara  
   as fashion icon, 2:46, 221  
   flapper style, 2:89  
 Bow Knot Tiara, 1:326  
 Bow-ties, 2:445  
 Bowerman, Bill, 3:196–197, 215  
 Bowie, David, 2:433, 3:67  
 Bowler hats, 2:179–180  
 Bowles, Carington and John, 1:226, 227  
 Bows, 3:338  
 Box look, 1:221

- Boxer shorts, **1:181–182**, 182  
 Boyars, 3:124–125  
 Boycotts, 3:249  
 Boyd, John, 2:185, 413  
 Boyle, Richard, 3:142  
 Bracelets, **1:182–184**, 2:279  
 Braiding, **1:184–185**  
 Braiding (hair), 2:158–159  
 Braies, 1:193  
 Bramani, Vitale, 3:214  
 Branding, **1:186–187**  
 Brando, Marlon, 2:222, 3:342  
 Brands and labels, **1:187–188**  
   advertising, 2:28–29  
   Callot sisters, 1:216  
   Cardin, Pierre, 1:225  
   clubwear, 2:432  
   color, 1:283  
   cosmetics, 1:299  
   Demorest, Madame, 1:358–359  
   Dior, Christian, 1:366  
   hip-hop style, 2:216  
   Hugo Boss, 2:229–230  
   Lang, Helmut, 2:329  
   Lauren, Ralph, 2:340–341  
   Margiela, Martin, 2:382  
   1990s fashion, 3:353  
   private labels, 3:88  
   sport shirts, 3:213  
   t-shirts, 3:343  
   watches, 3:411  
   Worth, House of, 3:448  
   *See also* Logos  
 Braniff Airways, 3:65  
 Branquinho, Veronique, *1:143, 144*, 145  
 Brantley, Ben, 3:440  
 Brassieres, **1:188–192**  
   development of, 3:361  
   Gernreich, Rudi, 2:136  
   sports bras, 3:361–362  
 Brathwaite, Kwame, 1:30  
 Bravo, Rosemary, *1:201*, 1:202  
 Brazil  
   carnival dress, 1:231  
   children's clothing, *1:257*  
   cosmetics, 1:294  
   history of dress, 1:45–46  
 Break dancing, 1:336, 2:215  
 Breast augmentation, 2:234, *234*, 3:40–41  
 Breeches, **1:192–195**  
   breeching, 1:256–257  
   doublets and, 1:375–376  
   women's equestrian costume, 1:412–413  
 Breton de la Martiniere, Jean Baptiste  
   Joseph, 2:17  
 Bretonne, Rétif de la, 1:227  
 Breward, Christopher, 2:20  
 Bricolage, 2:103, 3:233  
 Briefs, 1:182, 2:290  
 Brigance, Tom, 2:398  
 Brinkley, Christie, 3:243  
 Brisé fans, 2:6, 2:7  
 Britain Must Go Pagan collection, 3:429  
 British fashion. *See* Great Britain;  
   London fashion  
 British Imperial State Crown, 1:327  
 British *Vogue*, 1:50  
 Broadway, 1:335–336, 340  
 Brocades  
   Central Asia, 3:290  
   Jacquard weaving, 3:415  
   Japanese, 3:300, 301  
   Mexican dress, 1:39–40  
 Brodovitch, Alexey, 2:40, 228, 3:30  
 Brokaw, Lucile, 2:63  
 Bronze Age, 3:306–307  
 Brooches and pins, **1:195–197**, *196*, 2:98  
 Brooklyn Museum of Art, 2:61  
 Brooks, Jason, 2:49  
 Brooks, Romaine, 1:344  
 Brooks Brothers, **1:197–199**, 3:213  
 Brosseau, Jean-Charles, 2:413  
 Brotherston, Lez, 1:116  
 Brown, Helen Gurley, *2:55*  
 Brown, June, 2:453–454  
 Brownie uniforms, *1:258*  
 Brûlé, Tyler, 1:344  
 Brummell, George, **1:199–200**  
   bohemian dress, 1:172  
   boots, 1:174  
   dandyism, 1:341, 345–346  
   equestrian costume, 1:414  
   fashion interest, 2:132  
   formal wear, 2:111–112  
   neckwear, 2:445  
   suits, 3:237  
 Brunelleschi, Umberto, 2:49  
 Bryant Park shows, 2:53  
 Bubble-up theory. *See* Trickle-up theory  
 Buck, Anne, 1:329, 2:19  
 Buck, Joan Juliet, 3:440  
 Buckles. *See* Belts and buckles  
 Buddhist dress  
   Chinese textiles, 3:294  
   Han dynasty, 1:262  
   Japanese textiles, 3:299–300  
   Ladakh, 1:88  
   Nara era, 2:266–267  
   robes, *3:111*, 111  
   Tibet, 3:311  
 Buffalo 70 jeans, 2:274  
 Buffalo hide, 1:44  
 Buffalo style, 2:32  
 Bugle masks, 2:392  
 Bündchen, Gisele, 2:335, 3:244  
 Bundi, 2:449–450  
 Bunka-Bunsei period, 2:304  
 Burberry, **1:200–202**, 2:410, 3:79, 80  
 Burbridge, John, 2:38  
 Burial shrouds. *See* Shrouds  
 Burlesque, 3:230–231  
 Burlington Arcade, *3:179*  
 Burqa, *1:89*, **202–203**  
   Afghanistan, 2:253, 3:97  
   gender and power, 2:133, 3:95  
   India, 2:238  
   Maldives, 3:310  
 Burrows, Stephen, **1:203–204**  
 Burstein, Joan, 1:284  
 Bush, Barbara, 2:86  
 al-Bushairy, Yahya, *3:49*  
 Business attire  
   Brooks Brothers, 1:197–199  
   casual business dress, 1:236–237  
   dress for success, 1:378–380  
   gender and, 2:130–131  
   Hawaiian shirts, 2:189–190  
   Japan, 1:377, 2:261  
   maternity wear, 2:396  
   1970s, 3:352  
   1980s, 3:353  
   occupational uniforms, 3:372  
   skirts, 3:190  
   sports jackets, 3:216  
   suits, 3:236–238  
   turn of the twentieth century, 3:348  
   women's trousers, 3:341  
 Business Improvement Center (BID), 3:156  
 Business of fashion  
   Albini, Walter, 1:34  
   Balenciaga, Cristóbal, 1:109  
   brands and labels, 1:187–188  
   department stores, 1:361–363  
   Dior, House of, 1:366  
   Halston, 2:168  
   Paquin, House of, 3:16–17  
   pattern companies, 3:26, 28  
   *See also* Economics and clothing;  
   Fashion industry  
 Buster Brown shoes, 3:170  
 Bustle, **1:204–206**, *205*  
   hoopskirts, replacement of, 1:317  
   phases, 1:427  
 Butterflies, 2:423  
 Butterfly dandies, 1:341  
 Butterick, Ebenezer, 3:25, 86  
 Buttock augmentation, 2:235  
 Buttons, **1:206–209**, *207*, *2:72*, 3:338–339  
 B.V.D. swimwear, 3:253  
 Byrne, Kiki, 3:460  
 Byzantine Empire  
   jewelry, 2:280  
   rings, 3:109  
   textiles, 1:286–288  
   women's footwear, 3:173  
 Byzantine textiles, **3:286–288**
- ## C
- C. P. Company, 2:432  
 Cable television, 2:70–71  
 Cabochard (perfume), 2:152  
 Cabrera, Sylma, 2:335  
 Cache-sexe, **1:211–212**



- Caciededo, Jean Williams, 3:414  
 CAD (Computer Aided Design), 2:208, 3:28, 425  
 Cadwallder, Brooke, 3:143  
 Café society, 1:274  
 Caftans, **1:212–213**  
 Calandre (perfume), 3:78  
 Calf augmentation, 2:234  
 Calico, **1:213–215**, 214, 215, 217  
 Caliph dress, 2:404–405  
 Callot, Jacques, 1:225, 2:48  
 Callot sisters, **1:215–217**  
   art and fashion, 1:73  
   art deco, 1:77  
   embroidery of Michonet, 2:350  
   first modern fashion designers, 2:36  
   kimonos, 2:305  
   Orientalism, 3:5–6  
   society dresses, 3:348  
   Vionnet, Madeleine and, 3:401–402  
 Camargo, Marie, 3:43  
 Cambric, batiste, and lawn, 1:217, **217–218**  
 Cambridge University, 1:1  
 Camel hair, **1:218**, 3:303  
 Cameos, 2:282  
 Cameroon masks, 2:392  
 Camouflage cloth, **1:218–219**  
 Campbell, Naomi, 3:244, 395  
   Alaïa, Azzedine and, 1:32  
   diversity and fashion models, 2:59, 65  
   Meisel, Steven and, 2:401  
   as supermodel, 3:243, 244  
 Campos, Rubén, 2:335  
 Canada  
   fashion education, 2:42  
   Inuit clothing, 2:243, 246  
 Canal travel, 3:333  
 Canes and walking sticks, **1:219–221**  
 Cantillo, Lina, 2:335  
 Canvas  
   Demeulemeester's use of, 1:354  
   Vuitton, Louis, 3:408  
 Capes  
   Europe, 3:7–8, 9  
   Yeohlee, 3:458  
 Capitalism  
   dress for success, 1:379  
   Marx's criticism of, 2:386–387  
   nudism and, 2:459  
   social class and fashion, 1:133  
 Caplin, Roxey A., 1:291  
 Capping ceremonies, 1:260  
 Caps, 2:181  
 Caps and gowns, 1:1–2  
 Capsule dressing, 2:397  
 Capucci, Roberto, **1:221–222**, 2:254–255  
 Car racing helmets, 2:198  
 Carcanets, 2:442  
 Card weaving, 1:185, 2:364  
 Cardin, Pierre, **1:222–225**, 223  
   collarless jacket, 2:450  
   Courrèges, André, influence of, 1:309, 310  
   fashion shows, 2:69  
   haute couture, 2:188  
   licensing, 2:126  
   minidress, 1:224  
   Mod style, 2:430  
   1960s fashion, 3:351  
   perfume, 3:36  
   Rabanne, Paco and, 3:77  
   space age style, 3:200  
   sunglasses, 3:241  
   tailored suits, 3:261  
   unisex clothing, 3:383  
   vacuum-formed fabrics, 2:207  
   vinyl as fashion fabric, 3:400  
   youth style, 2:415  
 Carding, 3:210, 442  
 Care  
   acrylic and modacrylic, 1:3  
   feathers, 2:75  
   labeling laws, 2:320  
   polyester, 3:53  
   ramie, 3:81  
   rayon, 3:83  
   silk, 3:184  
 Caribou skin, 2:245, 247  
 Caricature and fashion, **1:225–230**, 226, 2368  
 Carita sisters, 2:161  
 Carmichael, Stokely, 1:26, 347  
 Carnaby Street fashions, 2:31  
 Carnegie, Hattie  
   Dahl-Wolfe photography of fashions by, 1:334  
   Gernreich, Rudi and, 2:136  
   Norell, Norman and, 2:457  
   recognition of, 2:36  
   women's hats, 2:184  
 Carnival dress, 1:230, **230–232**, 2:393–394  
*The Carol Burnett Show* (television show), 2:369  
 Carothers, Wallace, 2:461  
 Carpet weaving, 3:304  
 Carr, Zack, 2:307  
 Carter, Angela, 2:357  
 Carter, Michael, 3:198  
 Carthage, 1:17  
 Cartier, 3:438  
 Cartwright, Edmund, 3:211, 424  
 Carven, Marie-Louise, 2:188  
 Cashin, Bonnie, **1:232–233**  
   American fashion, 2:51  
   handbags, 2:172  
   Japonisme, 2:272  
   jumpers, 2:291  
   leather, 2:345  
   recognition of, 2:36  
   sportswear, 1:3, 3:221  
 Cashmere and pashmina, 1:233, **233–236**, 234  
 Cassidy, Carol, 3:318  
 Cassini, Oleg  
   fashion dolls, 2:38  
   Kennedy, Jacqueline, fashions for, 1:246, 2:48  
   women's hats, 2:185  
 Caste systems, 2:333  
 Castel-Bert, Mrs., 1:300  
 Castelbajac, Jean Charles de  
   Delaunay, Sonia, influence of, 1:352  
   duffle coats, 1:385  
 Castiglione, Countess, 1:355  
 Castillo, Antonio, 1:350, 3:206  
 Casual business dress, **1:236–238**, 380, 2:190  
 Casual wear  
   fashion change, 2:22  
   Levi Strauss, 2:353  
   social change, 2:23  
   *See also* Leisurewear; Sportswear  
 Catalina swimwear, 3:253  
 Catalog stores, 1:403, 3:102  
 Category killers, 3:101  
 Catherine II, 3:125  
 Catherinettes, 2:185  
 Cationic dyes, 1:388  
 Caughlan, Robyn, 1:102  
 Cautery branding, 1:186  
 Cavalier style, 2:163  
 Cavalli, Roberto, 3:7  
 Cavalry uniforms, 3:366  
 Cazaubon, Jean, 1:254  
 Celebrities, **1:238–240**  
   fashion designers as, 2:51, 52  
   fashion designers' use of, 2:36–37  
   fashion icons, 2:47  
   fashion models, 2:59, 65, 3:354–355  
   fashion shows, 2:53  
   fashion television, 2:71  
   Fontana sisters' designs, 2:104  
   Latino style, 2:335  
   music and fashion, 2:430–433  
   society celebrity models, 2:62  
   Versace, Donatella and, 3:396  
   vintage fashion, 3:399  
   *Women's Wear Daily* interviews, 3:440  
   *See also* Actors and actresses;  
   Supermodels; Specific celebrities  
 Cellulose fibers, 2:81–82, 3:81–83  
 Celtic dress  
   folk dress, 2:97–98  
   plain, 3:39  
   Samhain, 2:166  
 Center for the Promotion of Design and Fashion (CPDM), 3:206, 207  
 Central Africa, 2:158–159  
 Central American dress, **1:37–42**, 39  
   native headdresses, 2:194  
   tattoos, 3:269–270  
 Central Asian dress, **1:78–82**, 79, 80, 81  
   felt, 2:75–76  
   ikat, 2:232–233  
 Central Europe

- fashion education, 2:42  
folk dress, 2:95, 98–99  
textiles, 3:288–291
- Centre for Contemporary Cultural Studies (CCCS), 3:233, 234
- Centre International d'Etude des Textiles Anciens (CIETA), 3:421
- Ceramic buttons, 1:208
- Ceremonial and festival costumes, **1:240–246**  
armor, 1:70  
bark cloth, 1:125, 126  
beads, 1:134, 135  
boubou, 1:176  
canes and walking sticks, 1:220  
Central America and Mexico, 1:38, 40–41  
China, 1:409  
coronation robes, 3:112–113  
cosmetics, 1:293–295  
court dress, 1:313  
Ghanaian wrapper, 1:20  
headdresses, 2:194–195  
ikat, 2:232–233  
Korean traditional dress, 2:316  
mantillas, 2:193  
masks, 2:388–393  
military uniforms, 3:368  
North Africa, 1:18  
pagnes, 3:11  
robes of honor, 3:113  
Roma, 3:114  
Russian court dress, 3:122  
skullcaps, 2:285  
Spain, 3:205–206  
tapestries, 3:266  
women's hats, 2:185  
*See also* Rites of passage; Rituals; Wedding costumes
- Cerruti, Nino, 2:83, 222
- Césaire, Aimé, 1:28
- CEW (Cosmetic Executive Women), 3:57
- CFDA (Council of Fashion Designers of America), 2:53, 3:58
- Cha-cha dress, 1:339
- Chador, **1:246–247**, 247
- Chain mail, 1:69, 3:58–59
- Chain stores, 2:385–386, 3:179
- Chainse*, 1:420
- Chalayan, Hussein, **1:247–249**  
airplane dress, 2:206  
fashions of, 1:248  
knitwear, 2:310  
remote control dress, 2:209  
Tyvek fabrics, 2:208
- Challamel, Augustin, 2:17
- Chambre Syndicale de la Couture Parisienne  
art nouveau and, 1:76  
dominance of, 3:57  
Fath, Jacques, 2:73  
Grès, Madame, 2:152
- haute couture, 2:186–188  
*Les modes*, 2:55  
Mori, Hanae, 2:422–423  
Théâtre de la Mode, 2:73  
Treacy, Philip, invitation of, 3:335  
Valentino, 3:388
- Chanel, Gabrielle (Coco), **1:249–254**, 251  
A-Line, 1:35  
Albini, Walter, influence on, 1:33  
androgyny, 2:164  
art deco, 1:77  
ballet costumes, 1:116  
beach pajamas, 3:14  
body, liberation of the, 1:73  
brands and labels, 1:187  
celebrity, 2:51  
cocktail dresses, 1:274, 275  
costume design, 1:6, 2:83, 222  
costume jewelry, 1:302, 303, 303, 304  
fashion illustrators, 2:49  
on fashion/style distinction, 2:83  
flappers, 2:88  
folklore look, 2:102  
*garçonne* look, 3:22  
hats, 2:412  
Iribe, Paul and, 2:250  
jersey, 2:276  
jumpers, 2:291  
knitwear, 2:310  
lace, 2:326  
little black dress, 2:358–359  
modernity, 1:344  
nail polish, 2:439  
1910s fashion, 3:349  
1920s fashion, 3:349  
Norell, Norman, influence on, 2:457  
Paris fashion, 2:13, 3:19  
perfume, 3:35, 35  
on Rabanne, Paco, 3:77  
on Saint Laurent, Yves, 3:131  
simplicity, 1:131  
Soviet fashion show, 1:288  
Steele, Lawrence, influence on, 3:222  
street style, 2:46  
sweaters, 3:245  
tailored suits, 3:260  
tiaras, 1:326  
trickle up theory, 2:22  
tweeds, 3:347  
women's trousers, 3:383
- Chanel, House of  
bikinis, 1:157  
Courrèges, André, influence of, 1:311  
Diana, Princess of Wales, and, 1:363  
embroidery of Lesage, 2:351  
haute couture, 2:188–189  
Lagerfeld, Karl, 2:328  
Lil' Kim wearing fashions of, 2:216  
logos, 2:360  
1980s fashion, 3:352  
Paris fashion, 3:20  
precious jewelry, 1:305
- Treacy, Philip, 2:414
- Chanel 2005 handbag, 2:173
- Chanel No. 5 (perfume), 3:35, 35
- Change and fashion  
Baudrillard's theories, 2:16  
body/dress interrelationship, 1:64  
designers and fashion transformations, 2:26  
fashion industry, 2:50, 52  
fashion life cycles, 2:22–23  
gender and dress, 2:130  
Internet coverage, 2:61  
Laver, James, 2:342–343  
marketing and merchandising, 2:58  
Marx, Karl, 2:387  
modern art and, 1:75  
product innovation, 2:22  
ready-to-wear fashions, 3:87  
Simmel, Georg, 1:75, 3:186  
social class, 3:199  
traditional dress, 3:332  
Veblen's theories, 2:16
- Changshan*, 1:265
- Le chapeau mou*, 2:413
- Chapman, Ceil, 1:275
- Chapman, Frank, 2:74
- Chapman, Luman L., 1:188
- Chaps, 1:315
- Characteristics  
cotton, 1:307–308  
folk dress, 2:100  
silk, 3:183
- Chardonnet, Hilairede, Count, 3:82
- Charitable organizations, 3:84–85, 91, 151
- Charles, Prince, 1:363
- Charles Baudelaire* (Benjamin), 1:341
- Charles I, King of Austria-Hungary, 3:117
- Charles I, King of England, 1:423
- Charles II  
actors and actresses, influence of, 1:6  
beaver hat, 2:115  
suits, 3:236–237  
vests, 1:424  
waistcoats, 3:409  
wigs, 2:347
- Charles VII, 3:106
- Charleston dress, 1:339
- Charm bracelets, 1:183
- Chase, Edna Woolman  
editorship of *Vogue*, 2:40, 3:405  
Fashion Group, 3:57  
fashion shows, 2:69  
Hoyningen-Huene, George and, 2:228
- Chastity belts, 1:146
- Chasubles, 1:396, 1:398
- Cheap and Chic (boutique), 2:423–424
- Cheek implants, 2:234
- Chelsea district, 3:460
- Chemical dyes. *See* Dyes, chemical and synthetic

- Chemical scarification, 1:186, 3:144–145  
 Chemise dresses, **1:254–255**, 255, 256–257  
 Chenille yarns, 3:458  
 Cheongsam. *See* Qipao  
 Cher, 2:369, 369–370  
 Cheruit, Madeleine, 1:216, 274  
 Chest augmentation, 2:234  
 Cheviot tweeds, 3:346  
 Chi Wara, 2:391, 391  
 Chiffon, 1:316, 2:123  
 Children's clothing, **1:255–260**  
   Albanian folk dress, 2:96  
   Central Asia, 1:79  
   Communist dress, 1:287  
   Dolce & Gabbana, 1:371  
   fancy dress, 2:4–5  
   Halloween costumes, 2:166, 167  
   hook-and-loop closures, 1:270  
   India, 2:238  
   Inuits, 2:243, 243  
   Japanese fashion, 2:260  
   nautical style, 2:441  
   Roma, 3:116  
   Rome, ancient, 1:58  
   shoes, 3:169–171  
   Thailand, 1:98  
 Children's shoes, **3:169–3:171**, 170, 195  
 Chilkat blankets, 1:244, 3:307  
 Chin implants, 2:234  
 China  
   camel hair production, 1:218  
   Central Asia, trade with, 3:289  
   coercive power of government, 3:51  
   exports to Australia, 1:102–103  
   fashion education, 2:42  
   Greece's trade with, 1:55–56  
   Orientalism, 3:4–7  
   satin weaving, 3:418  
   silk, 1:82–83, 3:182  
   Southeast Asia, trade with, 3:316  
   trade with, 3:86  
   umbrellas, 3:357  
   velvet, 3:394  
 Chinese dress and fashion, **1:260–266**, 261, 262, 263, 265  
   beards and mustaches, 1:136  
   dragon robes, 3:113  
   embroidery, 1:409  
   ethnic dress, 1:415  
   fingernail length, 2:437  
   footbinding, 1:431, 2:106–109, 132  
   history, 1:83–84  
   Mao suits, 1:83, 280, 2:380–381, 381  
   qipao, 1:83, 415, 3:71  
   South Asian dress, influence on, 1:87  
   Vietnamese dress, influence on, 1:61, 84  
   wedding headdresses, 2:195  
 Chinese laundries, 2:339  
 Chinese textiles, **3:291–296**, 294, 319  
 Chino, 3:420  
 Chintes, 1:214–215  
 Chintz, **1:266–268**  
 Chipie, 3:213  
 Chipman, Richard Manning, 3:170  
 Chirac, Madame, 2:173  
 Chitons, 1:56–57  
 Chloé  
   embroidery, 1:409  
   Lagerfeld, Karl, 2:328  
   trench coats, 3:80  
 Choisy, Abbé de, 1:321  
 Cholo style, 2:335, 336  
*A Chorus Line* (musical), 1:340  
*Les Choses de Paul Poiret* (album), 3:46  
 Christensen, Helena, 3:243  
 Christianity  
   Balkan folk dress, 2:96  
   Coptic textiles, 3:296–299  
   cross-dressing, 1:321  
   crosses, 2:443  
   dress codes, 3:97–98  
   ecclesiastical dress, 1:395–400  
   jewelry, 2:280–281  
   Jewish dress restrictions, 2:286–287  
   Latin American colonialism, 2:333  
   missionaries, 1:95–97  
   missionaries and indigenous people's dress, 1:277  
   rings, 3:109  
   shoemaking, 3:164  
   veils, 3:393  
   wedding headdresses, 2:195  
   women and morality, 2:14  
   women's shoes, 3:173  
 Chuck Taylors, 3:171, 195–196, 214  
 Chullos, 2:308  
 Chun, Ellery, 2:189  
 Chung, Jane, 2:299  
 Chupa, 1:85  
 CIETA (Centre International d'Etude des Textiles Anciens), 3:421  
 Cinema Shop, 1:11, 2:222  
 Ciré, 2:142–143  
 Civic balls, 2:3, 4  
 Civil rights movement  
   Afro hairstyle, 1:25–26  
   West African dress, 1:16  
 Civil uniforms. *See* Occupational uniforms  
 Civil War  
   homespun fabrics, 2:223  
   reenactors, 3:92–94, 93  
 CK-1 (perfume), 3:36  
 cK fashion line, 2:307  
 Claiborne, Liz, 3:36  
 Clark, Edward, 3:158  
 Clark, Judith, 2:60  
 Clark, Kenneth, 2:460, 461  
 Clark, Larry, 2:203  
 Clark, Ossie, **1:268–269**  
   fashion icons, 2:47  
   fashion of, 1:269  
   London fashion, 2:362  
   Vionnet, Madeleine, influence of, 3:404  
   Youthquake fashion, 3:462  
 Clarke, John, 3:233  
 Classical dress, 2:17  
 Classicism  
   earrings, 1:392–393  
   Grés, Madame, 2:152–153  
   hairstyles, 2:163  
   Liberty & Co., 2:354  
   sandals, 3:136  
   Vionnet, Madeleine, 3:403–404  
   Westwood, Vivienne, 3:429  
   women's shoes, 3:175–176  
 Classification  
   acrylic and modacrylic, 1:2  
   colors, 1:281  
   dyes, 1:387–388  
   fashion industry pricing, 2:51  
   fibers, 2:81–82  
   nonwoven textiles, 2:455  
   rayon, 3:81–82  
   weave types, 3:421–422  
 Clayton, Lucie, 3:354, 355  
 Cleanliness, 2:339  
 Clert, Iris, 3:78  
 Clients  
   Balenciaga, House of, 1:109–110  
   Fontana sisters, 2:104  
   Halston, 2:168  
   James, Charles, 2:259  
   Lanvin, Jeanne, 2:332  
   Mainbocher, 2:374  
   Paquin, House of, 3:16, 17  
   Poiret, Paul, 3:47  
   Pucci, Emilio, 3:65–66  
   Schiaparelli, Elsa, 1:351  
   Valentina, 3:387–388  
   Worth, Charles Frederick, 3:449  
 Clinch, George, 2:18  
 Clinging garments, 1:32–33  
 Clinton, Bill, 2:202–203  
 Clinton, Hillary Rodham, 2:86  
 Clogs, 3:168  
 Clones, 2:32  
 Closménil, Mme Florensa de, 2:48  
 Closures, hook-and-loop. *See* Hook-and-loop closures  
 Clothing, costume and dress, **1:270–272**, 271, 272  
 Clothing cards, 2:11  
 Clover Leaf gown, 2:258  
 Club Les Dames Cotillion, 1:349  
 Clubs, cross-dressing, 1:321–323, 323  
 Clubwear designer labels, 2:431–432  
 CNN's *Style with Elsa Klensch*, 2:40–41, 53, 70  
 Coach  
   Cashin, Bonnie, 1:232–233  
   handbags, 2:172  
 Coats, **1:272–274**  
   cutaway coats, 3:348  
   driving coats, 1:273  
   duffle, 1:384–385



- duffle coats, 1:273  
 frock coats, 3:8, 348–349  
 greatcoats, 1:273, 3:8, 9  
 overcoats, 1:272–273  
 raincoats, 3:9, 3:79, 79–80  
 riding coats, 1:273, 3:217  
 trench coats, 2:410, 3:79, 80, 121  
 waistcoats, 3:409–410
- Cobain, Kurt, 2:153, 154  
 Cobb, John, 2:367  
 Cocker, Jarvis, 1:345  
 Cocktail dresses, 1:274–276, 275  
 1980s fashion, 3:353  
 1950s, 3:350–351
- Cocottes*, 1:355, 356  
 Cocteau, Jean  
 artistic dress, 3:413  
 Cardin, Pierre and, 1:223  
 Saint Laurent, Yves, influence on, 3:130  
 Schiaparelli, Elsa and, 2:49, 3:146
- Codpieces, 1:276, 276, 2:132, 3:29  
*Cofradías*, 1:41  
 Coigach tweeds, 3:346  
 Coke, Thomas, 1:341  
 Coker, J. K., 1:397  
 Colbert, Claudette, 3:14  
 Colbert, Jean-Baptiste, 3:106  
 Colby, Anita, 3:242  
 Cole of California, 3:253  
 Coleman, Nick, 2:432  
 Colin sisters, 2:48, 66  
 Collarless suits, 1:224, 2:450  
 Collars  
 dress shirts, 1:382–383  
 shirts, 3:162  
 wing, 1:383
- Collectibles  
 Barbie dolls, 1:121, 2:370  
 Blahnik shoes, 1:159  
 buttons, 1:209  
 fashion dolls, 2:39–40  
 fashion plates, 2:49, 66  
 Hawaiian shirts, 2:189  
 panama hats, 2:180  
 Shocking bottle (perfume), 3:36  
 Treacy, Philip, hats by, 2:414
- Collection of the Dresses of Different Nations, Ancient and Modern* (Jeffery), 2:17  
 Collins, Enid, 2:172  
 Colombia, 1:48–49  
 Colonial America  
 cosmetics, 1:295–296  
 dress, 1:424  
 harvest festivals, 2:167  
 legal and judicial costume, 2:347  
 spinning, 3:211
- Colonialism and imperialism, 1:277–280  
 Afrocentric fashion, 1:28  
 Andean textiles, 3:284–285  
 Australia, 1:101–102  
 China, 1:84  
 ecclesiastical dress, 1:397, 399–400  
 ethnic dress, 1:415  
*hijab* as reaction to, 2:212–213  
 knitting, 2:309  
 Latin America, 2:333  
 missionaries and dress of indigenous people, 3:99  
 Orientalism, 3:6  
 Pacific Islands, 1:95  
 Spanish, 1:47–48  
 Vietnamese dress, 1:61–62, 84
- Color, 1:280–283  
 adinkra cloth, 1:6  
 aesthetic dress, 1:12  
 Callot sisters, 1:216  
 Coptic textiles, 3:298  
 cosmetics, 1:294–295  
 costume jewelry, 1:303  
 cotton, 1:307  
 Delaunay's designs, 1:352  
 fur, 2:116  
 Gaultier, Jean-Paul, 2:128  
 gender and, 1:259, 2:129, 131  
 Gernreich, Rudi, 2:136  
 gloves, 2:147  
 golf clothing, 2:150  
 Greek dress, 1:55  
 Indian women's dress, 2:238  
 Korean fashion, 2:315–316, 317  
 Lacroix, Christian, 2:327–328  
 Lanvin, Jeanne, 2:332  
 leather, 3:265  
 legal and judicial costume, 2:346, 347  
 magical properties, 2:44  
 military uniforms, 3:364–365  
 Missoni, 2:416  
 mourning, 1:242  
 nail polish, 2:437–439  
 occult dress, 3:1  
 occupational uniforms, 3:371  
 photography, 2:64  
 prehistoric textiles, 3:306  
 Pucci, Emilio, 3:64–65  
 Southeast Asian textiles, 3:315  
 Umayyad dynasty, 2:404  
 wedding costumes, 3:426, 427  
*See also* Specific colors
- Color photography, 1:333  
 Colorfastness, 1:388  
 Coltman, Thomas and Mary, 1:411–412  
 Combat uniforms, 3:368  
 Combes, Sean, 3:438  
 Combing, wool, 3:442  
 Combs, hair, 2:158  
 Combs, Sean, 1:240, 2:217, 3:276
- Comfort  
 activewear, 1:4  
 golf clothing, 2:149–150  
 McCardell, Claire, 2:396–398  
 nylon, 2:462  
 Paquin, Jeanne, 3:18  
 techno-textiles, 3:272–273  
 wool, 3:443
- Coming of age. *See* Rites of passage  
 Coming-out balls. *See* Debutante dress  
 Comme des Garçons, 1:283–286, 284, 3:436  
 Commedia dell'arte, 3:322  
 Commercial artists, 2:28  
 Commercial dry cleaning, 1:384  
 Commercialization  
 psychedelic fashion, 3:63–64  
 punk, 3:68–69  
 Commissions, 3:84–85  
 Commodity fetishism, 2:387  
 Communication  
 adinkra cloth, 1:7–8  
 appearance and, 1:62–64  
 fans, 2:8  
 identity and dress, 1:272, 2:23–24  
 jewelry as means of, 2:277  
 Latin American fashion, 2:334  
 proverb cloths, 2:297–298  
 shamans' boots, 2:247  
 sweatshirts, 3:246  
 t-shirts, 3:342–343
- Communications technology, 2:117, 209, 3:273  
 Communist dress, 1:286–289, 287, 3:126
- Competition  
 fashion houses, 1:403  
 fashion magazines, 2:56  
 jeans, 2:353  
 pattern makers, 3:26  
 sweatshops, 3:249  
 Worth, House of, 3:449
- Complementary colors, 1:281  
*Complete Practical Guide to the Art of Dancing* (Hillgrove), 1:335  
 Complice, 2:432  
 Composite dress  
 colonialism, 1:279  
 rites of passage costumes, 1:242
- Composition, photographic, 1:178  
 Compound weave types, 3:422  
 Compressive shrinkage, 3:32  
 Computer Aided Design (CAD), 2:208, 3:28, 425  
 Computer industry, 1:236–237  
 Computer technology  
 cutting, 1:331  
 high-tech clothing, 2:45–46, 207, 209  
 pattern-making, 3:27, 27  
 sewing machines, 3:158  
 techno-textiles, 3:273
- Conceptual fashion, 2:20, 3:383–384  
 Condé Nast, 2:56, 3:26  
*See also* *Vogue*
- Confederate Civil War reenactors, 3:92:3:94  
 Congo, 2:391–393, 3:137  
 Conk hairstyle, 1:25  
 Connery, Sean, 3:345  
 Conspicuous consumption  
 headdresses, 2:163  
 royal and aristocratic dress, 3:118–119

- Conspicuous consumption (*continued*)  
 social class and status, 1:74–75, 3:198  
 Veblen, Thorstein, 3:390–391
- Conspicuous leisure, 3:198, 391
- Constantinople. *See* Byzantine Empire
- Construction  
 theatrical costumes, 3:323  
 Vionnet, Madeleine, 3:402–404  
 Worth, Charles Frederick, 3:448
- Constructivism  
 Delaunay, Sonia, 1:352  
 Exter, A., 3:126  
 Popova, L., 3:126  
 Rodchenko, Alexander, 3:126  
 Stepanova, V., 3:126  
 theatrical costumes, 3:323
- Consumerist Revolution, 3:377–378
- Consumers  
 Baudrillard, Jean, 1:132  
 department stores, 1:362  
 fads, 2:2  
 fashion leaders and followers, 2:23  
 fashion life cycles, 2:22–23  
 globalization of fashion, 2:143  
 government regulations, 3:48  
 labeling laws, 2:319–320  
 marketing for, 2:57  
 shopping, 3:178–180  
 Spanish fashion, 3:206  
 twentieth century marketing and distribution, 2:25  
*See also* Retailing; Shopping
- Consumption. *See* Conspicuous consumption; Consumers
- Contact dyeing, 1:389
- Contrasting colors, 1:281
- Controversies and scandals  
 attacks on fashion, 2:13–16  
 Barbie, 1:122–123  
 Beaton, Cecil, 1:139  
 bikinis, 1:156  
 chador, 1:247  
 Cher's costumes, 2:370  
 corsets, 1:290–291  
 cosmetics, 1:296, 297  
 ecclesiastical dress, 1:396–398  
 fur, 2:116  
 hair bobbing, 2:164  
 heroin chic, 2:202–203  
 Klein, Calvin, jeans advertising by, 2:306  
 leather, 2:345  
 McQueen, Alexander, 2:400  
 Meisel, Steven, 2:401–402  
 Patou's importation of American models, 3:23  
 Saint Laurent, Yves, 3:131, 133  
 thong underwear marketing, 2:121–122  
 U.S. Army issued black berets, 1:150  
*Women's Wear Daily*, 3:440
- Converse, Marquis, 3:214
- Converse Chuck Taylors, 3:171, 195–196, 214
- The Cook, the Thief, His Wife and Her Lover* (film), 2:83
- Cool, 2:217–218
- Cool colors, 1:281–282
- Cooperativa de Alta Costura, 2:188
- Copper, 1:43
- Coptic textiles, 1:396, **3:296–299**
- Copying  
 department store collections, 2:51  
 fashion designers, 3:103–104  
 press coverage of, 2:53  
 Vionnet, Madeleine, fashions of, 3:404
- Cord yarns, 3:458
- Cordonniers*. *See* Shoemaking
- Corduroy, **1:289–290**
- Cordwainers*. *See* Shoemaking
- Cornrowing, 2:158–159
- Coronations, 1:325, 3:112–113
- Coronets, 1:327
- Corpo Nove, 2:117
- Corporate fashion. *See* Business attire; Occupational uniforms
- Corres, Joseph, 2:357
- Corsets, **1:290–292, 291**  
 aesthetic movement's rejection of, 1:12  
 brassieres, replacement by, 1:189–190  
 caricature, 1:226  
 cross-dressing, 1:322  
 dress reform, 2:15–16  
 as extreme fashion, 1:431  
 as fashionable, 3:360–361  
 fetish fashion, 2:81  
 as gender marker, 2:132  
 health aspects, 1:381, 2:44–45  
 Madonna, 2:371, 372  
 Poiret, Paul, 3:45  
 satin, 3:419  
 tea gowns, 3:272  
 tight-lacing, 3:328–329  
 twentieth century, 3:348
- Cortefiel, 3:206
- Cosmeceuticals, 1:299–300
- Cosmetic Executive Women (CEW), 3:57
- Cosmetic surgery. *See* Plastic and cosmetic surgery
- Cosmetics, **1:292–295, 295–300**  
 beauty kit, 1:298  
 Chanel, Gabrielle (Coco), 1:252  
 department store counter, 1:297  
 Factor, Max, 2:221  
 Germany, 2:11  
 Henna tattoos, 1:294  
 India, 2:238  
 lipstick, 2:357–358  
 makeup artists, 2:374–375  
 New Guinea tribesman, 1:293  
 Quant, Mary, 3:74  
 Rome, ancient, 1:58  
 semipermanent tattoos, 3:270  
*See also* Theatrical makeup
- Cosmocorps, 1:224
- Cosmopolitan* (magazine), 2:55
- Costume design, **1:300–302, 301**  
 Adrian, 1:10–11, 2:222  
 Capucci, Roberto, 1:221  
 Cashin, Bonnie, 1:232  
 Chanel, Gabrielle (Coco), 1:251, 254  
 couturier/costume designer distinction, 2:83  
 Fath, Jacques, 2:73  
 Fendi, 2:78  
 Ferragamo, Salvatore, 2:221–222  
 Fontana sisters, 2:105–106  
 Gaultier, Jean-Paul, 2:128  
 Gernreich, Rudi, 2:136  
 Head, Edith, 2:191–192  
 Hilfiger, Tommy, 2:213–214  
 Iribe, Paul, 2:250  
 Lacroix, Christian, 2:328  
 Lucile, 2:365  
 Mackie, Bob, 2:369–370  
 Norell, Norman, 2:457  
 Rabanne, Paco, 3:78  
 Rhodes, Zandra, 3:105  
 Russia, 3:125–126  
 Saint Laurent, Yves, 3:130  
 Schiaparelli, Elsa, 2:82, 3:147  
 Sy, Oumou, 3:256  
 Valentina, 3:387–388  
 Valentino, 3:389  
*See also* Film and fashion; Hollywood style; Theatrical costumes
- Costume histories. *See* Historical studies of fashion
- Costume Institute, 2:60, 3:407
- Costume jewelry, **1:302–306, 303, 305, 393**
- Costume Society of America, 2:61
- Costumes. *See* Carnival dress; Clothing, costume and dress; Halloween costumes; Masquerade and masked balls
- Cosway, Richard, 2:367, 368
- Cote-hardie*, 1:420
- Cotillions, 1:348
- Cotton, **1:306–309, 307**  
 calico, 1:213–215  
 cambric, 1:217  
 Central Asia, 3:290, 291  
 China, 1:264  
 chintz, 1:266  
 flannel, 2:88  
 health aspects, 2:44  
 Japanese weaving techniques, 3:301  
 Middle East, 3:303  
 Ming dynasty, 3:295  
 muslin, 2:434–435  
 Southeast Asia, 3:314  
 textile trade, 3:319  
 yarn production, 3:456  
 yukata, 3:463
- Cotton gin, 1:306, 308, 3:211
- Coty Award  
 Beene, Geoffrey, 1:140  
 Burrows, Stephen, 1:203

- Cashin, Bonnie, 1:232, 233  
 De la Renta, Oscar, 1:351  
 Ellis, Perry, 1:406  
 Fogarty, Anne, 2:92  
 Galanos, James, 2:124  
 Halston, 2:168  
 James, Charles, 2:259–260  
 Klein, Calvin, 2:306  
 Norell, Norman, 2:457  
 Couching, 1:407–408  
 Council of Fashion Designers of America (CFDA)  
 Blahnik, Manolo, awards won by, 1:159  
 fashion journalism, 2:53  
 Klein, Calvin, award won by, 2:306  
 Klensch, Elsa, award won by, 2:70  
 Mackie, Bob, award won by, 2:370  
 membership, 3:58  
 Council of Latin American Fashion Designers, 2:335  
 Counterculture. *See* Subcultures  
 Counterfeit logos, 2:217, 361  
 Courrèges, André, **1:309–311, 311**  
 bonded jersey, 2:207  
 fashion models, 2:59  
 fashions of, *1:310*  
 future of fashion, 2:117  
 miniskirts and boots, 2:415  
 1960s fashion, 3:351  
 retro style, 3:103  
 Saint Laurent, Yves, comparison with, 3:131  
 space age styles, 3:199–200  
 sunglasses, 3:241  
 tailored suits, 3:261  
 vinyl as fashion fabric, 3:400  
 Youthquake fashion, *3:460*  
 Courrèges, Coqueline, 3:200  
 Court carpets, 3:304  
 Court dress, **1:312–314**  
 Bertin, Rose, 1:150  
 Brummel, George, 2:111–112  
 Byzantine textiles, 3:286  
 China, *1:265*  
 dance costumes, 1:337  
 embroidery, 1:408  
 hairstyles, 2:160  
 Japan, 2:266, 267  
 jewelry, 2:281–282  
 liveries, 3:369  
 Macaroni dress, 2:367–368  
 mantua, 2:380  
 Middle Eastern Islam, 2:404–408  
 mourning dress, 2:425  
 ribbons, 3:106  
 robes, 3:112–113  
 Russia, 3:122  
 South Asian dress, influence on, 1:87  
 Spain, 3:205  
 trendsetters, 3:335  
 women's hats, 2:182–183  
 women's shoes, 3:175  
  
*See also* Royal and aristocratic dress  
 Courtesans, 1:355–357  
 Courtly love, 2:170  
 Cousson, Mme Charles, 2:38  
 Covert coats, 1:273  
 Coward, Noel, 1:6, 344  
 Cowboy clothing, *1:314, 314–316, 315*  
 homosexuals, 2:33  
 Levi Strauss, 2:352, 353  
*See also* Western wear  
 Cox, Hilton, 1:231  
 CP Company, 1:4  
 CPDM (Center for the Promotion of Design and Fashion), 3:206, 207  
*Cracow. See* Pointed toe shoes  
 Craik, Jennifer, 2:20, 103  
 Crali, Tullio, 2:119  
 Crane, Walter, 3:412  
 Cravats, 2:444–445, *445*  
 Crawford, Cindy, 2:71, 3:243  
 Crawford, Joan, 1:10, 11, 2:89, 89  
 Crazy Horse Saloon, 3:77  
 Creed, Charles, 3:347  
 Creed, Henry, 3:348  
 Creole fashion, 2:333, 3:284  
 Crepe, *1:316, 316*  
 Crepe de chine, *1:316*  
 Crete, ancient, 1:55  
 Cricket uniforms, 3:380  
 Crinolines, **1:317–318**, 426–1:427  
 Crochet, **1:318–319**  
 Crombie coat style, 3:149  
 Crompton, Samuel, 3:211, 212  
 Cromwell shoes, 2:205  
 Cross Colors, 2:216  
 Cross-dressing, **1:319–324, 320, 323, 2:29, 31**  
*See also* Gender, dress and fashion  
 Crosses, 2:442, 443  
 Crow, Nancy, 3:75  
 Crown of Charlemagne, 1:327  
 Crowns and tiaras, 1:245, **324–327, 325**  
 Crucifixes, 2:442, 443  
 Cruikshank, Isaac, Robert and George, 1:228  
 Crusades, 1:419–420  
 Cruso, Thalassa, 2:18  
 Cuba  
 carnival dress, 1:230  
 socialism and fashion, 2:334  
 Cubism, 3:22  
 Cuff links and studs, **1:327–328, 2:111**  
*Culotte*, 3:340  
 Cult of the celebrity, 1:239  
 Cult of the golden lotus, 2:107–108  
 Cultural aspects of dress  
 African American dress, 1:14–16  
 Afrocentric fashion, 1:28, 30  
 Andes, 3:285–286  
 appearance, 1:63–64, 2:23–24  
 aprons, 1:65–66  
 ball dress, 1:112  
 Barbie, 1:121–123  
 beards and mustaches, 1:136–137  
 Benjamin on French fashion, 1:147–148  
 body piercing, 1:166–169  
 boubous, 1:176–177  
 bracelets, 1:184  
 cache sexe, 1:211–212  
 caricature, 1:226  
 ceremonial costumes, 1:243–244  
 dashikis, 1:346–347  
 debutantes, 1:349  
 dress for success, 1:378  
 extreme fashion, 1:430  
 fur, 2:116  
 gender, 2:128–133  
 Hawes, Elizabeth, 2:190  
 health and dress, 2:45  
 identity, 1:272  
 indigenous people and missionaries, 1:277  
 Mallarmé, Stéphane, 2:376–377  
 Pacific Island dress, 1:95–96  
*pagnes*, 3:11–12  
 penis sheaths, 3:29–30  
 pockets, 3:42  
 Simmel, George, 2:18  
 Southeast Asian textiles, 3:315  
 Veblen, Thorstein, 2:18  
 Culture Area, 1:45  
 Cumberbunds, 2:111  
 Cunningham, Bill, 2:53, 3:440  
 Cunningham, Merce, 1:339, 340  
 Cunnington, C. Willett and Phillis, **1:328–330**, 2:18, 19, 60  
 Cuprammonium rayon, 3:82  
 Curly Afros, 1:27  
 Custin, Mildred, 2:306  
 Custom tailoring, 3:261–264  
 Customization, mass, 2:208–209  
 Cutaway coats, 3:348  
 Cutex advertisement, *2:438*  
 Cutting, **1:330–332**  
 Demeulemeester, Ann, 1:353–354  
 mantua, 2:380  
 Rhodes, Zandra, 3:104–105  
 tailors, 3:262  
 Vionnet, Madeleine, 3:350, 401–404  
 Cutting (scarification), 3:144  
 Cutwork, 2:325  
 Cybergoth, 2:151  
 Czech Republic, 2:95  
  
**D**  
 Da Vinci, Leonardo, 3:212  
 Daché, Lilly, 2:184, 413  
 Dahl-Wolfe, Louise, **1:333–334**  
 color fashion photography, 2:64  
 documentary approach, 2:64  
 fashion editors and, 2:40  
 Vreeland, Diana and, 3:407  
 Daisy motif, 1:309



- Dale, Julie, 3:414  
 Dalí, Salvador, 1:72, 2:49, 3:78, 146, 147, 435  
 Damasks  
   Jacquard weaving, 3:415  
   Japan, 3:300  
 Damp cold and illness, 2:43–44  
 Damphene, 1:383–384  
 Dan masks, 2:392  
 Dance and fashion, 1:30, **334–336**  
 Dance costumes, **1:336–341**  
   shoes, 3:323  
   striptease, 3:230–231  
   Tang dynasty, 1:263  
 Dandré Bardon, Michel-François, 2:17  
 “The Dandy in Me” (Lucchesi), 1:344  
*The Dandy* (Moers), 1:343  
 Dandyism, **1:341–346**  
   Balzac, Honoré de, 1:117–119  
   Barthes, Roland, 1:127  
   Baudelaire, Charles, 1:131  
   bohemian dress, influence on, 1:172  
   boots, 1:174  
   Brummell, George, 1:199–200  
   dress shirts, 1:382  
   formal wear, 2:111–112  
   London fashion, 2:361  
   Macaroni dress and, 1:334  
   neckwear, 2:445  
   *The New Avengers* (television show), 3:235  
   Proust, Marcel, 3:61  
   *sapeurs*, 3:137  
   Savile Row, 3:142  
   shirts, 3:162  
   subcultures, 3:232  
*Du dandyisme et de Georges Brummell* (D’Aurevilly), 1:341, 343  
 Danforth, Charles, 3:212  
 Daniels, Bebe, 3:340  
 Dapper Dan, 2:216  
 Dark Ages, 1:418  
 Dark denim, 2:275  
 Darly, Matthew and Mary, 1:226, 227  
 Dashikis, 1:20, **346–348**, 347  
 Dassler, Adolf and Rudolf, 3:196, 214  
 Daumier, Honoré, 1:228, 2:394  
 Daves, Jessica, 2:40, 3:405  
 David, Jean-Louis, 2:161  
 David, Jules, 2:66  
 Davies, George, 2:386  
 Davies, Jessica, 2:225  
 Davies, Nigel, 3:355  
 Davis, Angela, 1:26, 27  
 Davis, Bette, 3:240  
 Davis, Jacob, 1:360, 2:273, 352  
 Dawes, John, 1:226  
 Day, Corinne  
   fashion icons, 2:47  
   realist aesthetic, 2:203  
 Daywear  
   Balenciaga, Cristóbal, 1:110  
   formal, 2:111  
   Vionnet, Madeleine, 3:403  
 De Brunhoff, Michel, 3:130  
 De la Haye, Amy, 2:60  
 De la Peña, José, 1:376–377  
 De la Renta, Oscar, 1:350, **350–351**  
   celebrity, 2:52  
   Council of Latin American Fashion Designers, 2:335  
   embroidery of Lesage, 2:351  
   Maison Balmain, work for, 1:117  
   polyester, 3:53  
   Seventh Avenue, 3:157  
 De Meyer, Adolf, 2:62  
 De Sole, Dominico, 2:156  
 Dean, James, 2:222, 273, 274, 3:342  
 Deangle masks, 2:392  
 Death. *See* Funerary and burial rituals; Mourning dress  
 Debucourt, Philibert Louis, 1:228  
 Debutante dress, 1:348, **348–350**, 2:336  
 Debutante slouch, 2:88  
 Deconstruction  
   Comme des Garçon, 1:284  
   Margiela, Martin, 2:381–382  
   t-shirts, 3:343  
   unisex clothing, 3:384  
   Yamamoto, Yohji, 3:453–455  
 Decorative prints  
   adinkra cloth, 1:6–8, 7, 8  
   *adire*, 1:8–10  
   Adrian, 1:11  
   African textiles, 3:282  
   animal prints, 1:59–60  
   bark cloth, 1:125  
   batik, 1:129–130  
   bogolan, 1:169–170  
   calico, 1:213–215  
   Central Asian textiles, 3:290–291  
   chintz, 1:266–267  
   Clark, Ossie, 1:268  
   Fortuny, Mariano, 2:113–114  
   Hawaiian shirts, 2:189–190  
   Hermès scarves, 2:202  
   ikat, 2:232–233  
   kimonos, 2:303–305  
   Liberty & Co., 2:354  
   Marimekko, 2:383–385  
   North African dress, 1:17–18  
   paisley, 3:12–13  
   paper dresses, 3:15–16  
   Patou, Jean, 3:22–23  
   Pucci, Emilio, 3:64–65  
   Rhodes, Zandra, 3:104–105  
   scarves, 3:143  
   Southeast Asian textiles, 3:313–314  
   Sub-Saharan Africa, 1:22  
 Decorative stitching, 1:203, 3:301–302  
 Deer-hide, 1:44  
 Deineg, Irina, 3:127  
 Delaney, Thomas, 3:169–170  
 Delaunay, Sonia, **1:351–353**  
   art deco, 1:77  
   artistic dress, 3:413  
   Ellis’s homage to, 1:407  
   1920s fashion, 3:349  
   simultaneous dresses, 2:119  
 Delhomme, Jean-Philippe, 2:49  
 Demand, 1:401  
 Demarchelier, Patrick, 3:243  
 Dembski, Lenore, 1:102  
 Demeulemeester, Ann, **1:353–354**  
   Belgian fashion, 1:144  
   Japanese influence, 2:265  
   1990s fashion, 3:353  
   unisex clothing, 3:384  
 DeMille, Cecil B., 2:250  
 Demimonde, **1:354–357**, 2:330  
 Democratization of fashion, 2:25, 3:175, 199  
 Demography, 3:276  
 Demorest, Madame, **1:358–359**  
   fashion publications, 3:26  
   pattern envelopes, 3:28  
   patterns and patternmaking, 3:25–27  
 Denim, **1:359–360**  
   distressing, 1:368–369  
   Indian production, 2:240  
   jeans, 2:273, 275  
   street style, 3:225  
   twill weave, 3:420  
 Denmark, 1:313  
 Dental implants, 2:234  
 D’Eon, Charles, 1:322  
 Department stores, 1:361, **361–363**  
   Balenciaga line, 1:110  
   boutiques *vs.*, 1:153  
   cosmetics counters, 1:297  
   fashion models, 2:59  
   fashion shows, 2:68, 69  
   first, 1:402  
   mannequins, 2:377, 378  
   mergers, 2:52  
   private labels, 3:87–89  
   ready-to-wear, 3:87  
   retailing, 3:100–101  
   shopping, 3:179  
   window displays, 3:434–436  
 Depero, Balla and Fortunato, 2:119  
 Depero, Marinetti, 2:119  
 Derain, André, 3:47  
 Derby hats, 2:179–180  
*La dernière mode*, 2:376  
 Descart, Rose, 2:412  
*Désabillé*, 3:402  
*Design for Ballet* (Clarke and Crisp), 1:116  
 Design rooms, 2:36  
 Designer eyewear, 1:433–434  
 Designer fragrances, 3:35–36  
 Designer handbags, 2:169, 172–173  
 Designer jeans, 2:274–275, 306, 353  
 Designer sunglasses, 3:241, 242  
 Désirat, Mme, 2:38  
 Despeissis, Louis-Henri, 3:82  
 Desrais, 2:66  
 Desrues, 1:254

- Dessange, Jacques, 2:161  
 Dessès, Jean, 2:188, 350  
*Deutsches Mode-Institut*, 2:9  
*Deux pagnes*, 3:11  
 Developing countries  
   garment production, 2:143–145  
   handwoven textiles, 2:174  
   secondhand clothes, 3:152–153, 154  
   sweatshops, 3:247–248, 249  
   textile trade, 3:319–320, 321  
   used clothing, 3:91  
 Dew, Diana, 3:63  
 Dhoti, 2:237  
 Diadems, 1:324–325  
 Diaghilev, Sergei  
   ballet costumes, 1:115–116  
   *en pointe*, 3:43  
   “Russian Seasons” program, 3:126  
   “A Thousand and One Nights,” 3:5  
 Diamond earrings, 1:393  
 Diamond Jubilee, 2:4  
 Diana, Princess of Wales, **1:363–364**, 364  
   celebrity, 1:240  
   as fashion icon, 2:47  
   hats, 2:185, 413  
   maternity dress, 2:395  
   Rhodes, Zandra, fashions of, 3:105  
   tiaras, 1:326  
   wedding dress, 3:38  
 Diapers, disposable, 2:455, 456  
 Dickens, Charles, 1:137  
 Dickinson, Janice, 3:243  
 Diesel, 2:255, 3:213  
 Dietrich, Marlene, 2:129  
   demimonde, influence of the, 1:357  
   as fashion icon, 2:46–47  
   Maddona, influence on style of, 2:371  
   sunglasses, 3:240  
   tailored suits, 3:261  
   trousers, 3:220, 340, 341  
 Differentiation, 3:336  
 Diffusion, 2:22  
 Dighton, Robert and Richard, 1:228  
 Digital art production, 2:49–50  
 Dill-Scott, Walter, 3:434  
 Dinner jackets, 2:257, 3:131, 345  
 Dinner suits, 1:274  
 Dinnigan, Collette, 1:103  
 Diop, Cheikh Anta, 1:28  
 Dior, Christian, **1:364–368**, 365  
   A-Line, 1:35, 35  
   Alaïa, Azzedine, designs by, 1:32  
   bouffant skirts and petticoats, 3:37  
   caftan style, 1:212  
   Cardin, Pierre and, 1:223, 224  
   chemise dress, 1:255, 255  
   cocktail dresses, 1:275  
   costume jewelry, 1:304  
   embroidery, 1:409, 2:350  
   eyewear, 1:434  
   fashion icons, 2:47  
   fashion models, 2:59  
   fashion transformation, 2:26  
   fashions of, 2:451  
   film and fashion, 2:83  
   folklore look, 1:339, 2:103  
   *Gone with the Wind*, influence of, 2:222  
   Gruau, René and, 2:49  
   haute couture, 2:187  
   hemlines, 2:199, 199  
   high heels, 2:204, 205  
   homosexuality, 2:32  
   little black dress, 2:359  
   Moscow fashion show, 1:288  
   New Look, 2:451–452, 3:20  
   1950s fashion, 3:350  
   1940s fashion, 3:350  
   Paris fashion, 2:13  
   perfume, 3:36  
   retro style, 3:103  
   Saint Laurent, Yves, similarity of, 3:130  
   stockings, 3:223, 224  
   t-shirts, 3:343  
   tailored suits, 3:261  
   Windsor, Duchess of, 3:438  
 Dior, House of  
   Diana, Princess of Wales, and, 1:363  
   embroidery of Lesage, 2:351  
   fashion shows, 3:325  
   Galliano, John, 2:125, 126  
   handbags, 2:172  
   haute couture, 2:189  
   logo, 2:361  
   milliners, 2:412  
   1990s fashion, 3:353  
   Paris fashion, 3:20  
   rubber wear, 3:121  
   sweaters, 3:245  
   Treacy, Philip, 2:414  
 Diplomacy, 3:292, 294–295  
 Diplomatic uniforms, **3:362–364**, 363  
 Dirandole earrings, 1:392  
 Direct dyes, 1:388  
 Dirndl fashion, 2:9–10  
 Dirndl skirts, 2:99  
 Dirty denim, 2:276  
 Disarming Acts, 3:148, 267  
 Disco  
   Burrows, Stephen, 1:203  
   dance and fashion, 1:336  
   disco bags, 2:172  
   music and fashion, 2:433–434  
 Discount stores, 3:101  
 Diskilting Act, 2:301  
 Disperse dyes, 1:388  
 Displays. *See* Window displays  
 Disposable diapers, 2:455, 456  
 Distaffs, 3:210  
 Distressing, 1:368–369  
 Distribution  
   fashion, 2:21–22  
   ready-to-wear, 3:87  
   twentieth century, 2:25  
 Diversification  
   Cardin, Pierre, 1:225  
   Fendi, 2:77  
   Gigli, Romeo, 2:138  
   Karan, Donna, 2:299  
   patterns, 3:28  
   Rhodes, Zandra, 3:105  
   Rykiel, Sonia, 3:128  
   Westwood, Vivienne, 3:429  
 Dixon, Harland, 1:340  
 DJ Kook Herc, 2:215  
*Djellaba*, **1:369–371**  
 DKNY, 2:299, 3:102  
 Dobby looms, 2:364  
 Dodd, William, 2:367, 368  
 Dolce & Gabbana, **1:371–372**, 372  
   animal print coat, 1:60  
   designer jeans, 2:275  
   folklore look, 2:103  
   folkloric theme, 1:339  
   grunge, 2:154  
   hip-hop style, 2:217  
   Italian fashion, 2:255  
   lingerie as outerwear, 2:357  
   Madonna’s collaboration with, 2:371  
   military style, 2:410  
   1990s fashion, 3:353  
   Scottish textiles, 3:149  
   sweatshirts, 3:246  
   transparent outerwear, 3:15  
   waistcoats, 3:410  
 Dolls  
   Barbie, 1:121–123, 122  
   doll clothes reproduced for humans, 2:382  
   fashion, 2:38–40  
 Dolpos, 1:90  
 Domestic furnishings, 3:415  
 Domestic patterns, 3:26  
 Domestic production, **1:372–374**  
   crochet, 1:318–319  
   folk dress, 2:100  
   homespun fabrics, 2:223  
   Japanese textiles, 3:300  
   knitting, 2:308–309  
   patterns, 1:358–359  
   Southeast Asian textiles, 3:316  
   spinning, 3:210  
 Domínguez, Adolfo, 3:207  
 Domino handbag, 2:173  
 Donald, Diana, 2:368  
 Donegal tweeds, 3:347  
*Donna* (periodical), 1:372  
 Donne, John, 3:181  
 Donovan, Carrie, 2:40  
 Doré, Gustave, 1:228  
 Doric chitons, 1:56–57  
 Doric peplos, 1:56  
 Dorsey, Hebe, 2:54  
 Double weaves, **3:414–415**  
 Doublet ikat, 2:231  
 Doublets, **1:374–376**, 375  
 Doucet, House of  
   fashion shows, 2:67–68

- Doucet, House of (*continued*)  
 Vionnet, Madeleine, 3:402
- Doucet, Jacques, **1:376–377**  
 art and fashion, 1:73  
 art nouveau, 1:76  
 demimonde, influence of the, 1:356  
 embroidery of Michonet, 2:350  
 fashion dolls, 2:38  
 first modern fashion designers, 2:36  
 Poiret, Paul and, 3:44  
 tailored suits, 3:260
- Dovima, 2:64
- Dow Corning, 2:234
- Dow XLA, 1:405
- Dowries, 3:309
- Doyle, Jimmy, 1:340
- Draft, weave, 3:422
- Dragon robes  
 Ming dynasty, 1:264  
 rank of wearer, 1:83  
 Song dynasty, 1:264
- Draper, Paul, 1:340
- Draping  
 defined, 1:51  
 Egypt, ancient, 1:54  
 Grès, Madame, 2:153  
 mantua, 2:380  
 saris, 3:138–140  
 South Asia, 1:86  
 Southeast Asian textiles, 3:313  
 togas, 3:330  
 Vionnet, Madeleine, 3:402–404
- Draw looms, 3:415
- Drawers  
 breeches and, 1:192  
 women's, 3:15
- Drécoll, 1:302
- Dress Code* (Fischer-Mirkin), 1:164
- Dress codes, **1:377–378**  
 businesses, 3:49–50  
 colonialism, 1:277–278  
 gender, 2:130–131, 3:49  
*bijab*, 2:212  
 homosexuality, 2:31–32  
 Latin American fashion, 2:334  
 legal and judicial costume, 2:346–348  
 Middle Eastern Islamic dress,  
 2:403–409  
 religious, 2:133, 3:96–100  
 schools, 3:50, 374–378  
 uniform/dress code distinction, 3:375
- Dress for success, **1:378–380**, 3:352
- Dress manuals, 1:378–380
- Dress reform, **1:381–382**  
 aesthetic movement and, 1:12  
 anti-footbinding movement, 2:108–109  
 artistic dress, 3:412  
 Bloomer costume, 1:161–163, 426  
 bohemian dress, 1:172  
 brassieres, 1:188–189  
 Empire style, 1:411  
 Flügel, J.C., 2:90–91  
 health-based, 2:15–16
- Italian futurist fashion, 2:119
- Middle Eastern Islamic dress, 2:408
- Peter I, 3:124–125
- Dress shirts, **1:382–383**
- Dresses  
 chemise, 1:254–255  
 cocktail, 1:274–275  
 empire-line, 1:261, 262–263, 264  
 hooped, 3:448  
 jumpers, 2:291  
 little black dress, 1:250–251, 274, 302,  
 2:358–360, 359, 3:349  
 “Paper doll” dress, 2:92  
 poem-dresses, 1:352  
*qipao*, 1:83, 266, 3:6–7, 71  
 rococo style, 1:424–425  
 shirtwaists, 3:162–164  
 slip dresses, 3:192  
 taxi dresses, 2:258  
 toga dresses, 3:330  
*See also* Gowns
- Dressmaking  
 Lamanova, N., 3:126  
 Vionnet, Madeleine, 3:401–404  
*See also* Seamstresses; Tailoring and  
 tailors
- Dreyfus, Alfred, 3:61
- Dreyfus, Camille and Henry, 3:82
- “Drinking Woman,” 1:274
- Driving coats, 623
- Driza-Bone, 3:3
- Dry cleaning, **1:383–384**, 3:53
- Dryden, Helen, 2:67
- Du Maurier, George, 1:12
- Duchamp, Marcel, 3:146
- Duckworth, Susan, 2:310
- Dude ranches, 1:315
- Dudel, Yvonne, 1:254
- Duff-Gordon, Lady, 2:364–365
- Duffle coats, 1:273, **1:384–385**
- Dufy, Raoul, 3:47
- Duke and Dutchess of Windsor,  
**3:436–438**, 437  
 dinner jackets, 3:345  
 Edwardian fashion, 3:348  
 as fashion icons, 2:46  
 golf clothing, 2:149  
 Mainbocher, 2:373, 373  
 tattoos, 3:270
- Duncan, Isadora, 1:339, 3:143
- Dungarees. *See* Jeans
- Dunlop Green Flash shoes, 3:195
- Dupatta*, 3:392
- DuPont  
 elastomers, 1:405  
 Fiber K, 2:140  
 nylon, 2:461  
 polyester, 3:52
- Duppioni silk, 3:183
- Durable-press fabrics, 3:32–33
- Durst, André, 2:64
- Dyeing, **1:385–386**, 386  
 acrylic and modacrylic, 1:3
- adire*, 1:8–10
- Andean textiles, 1:46
- bark cloth, 1:125
- batik, 1:129–130
- bogolan, 1:170
- boubous, 1:175–176
- buttons, 1:208
- Byzantine textiles, 3:287
- calico, 1:213, 215
- Central American and Mexican textiles,  
 1:39
- chintz, 1:267
- denim, 1:360
- Fortuny, Mariano, 2:113–114
- Greek textiles, 1:56
- ikat, 2:231–233
- indigo, 2:241–242
- Japanese textiles, 3:301
- Lanvin, Jeanne, 2:332
- leather, 3:265
- Middle East textiles, 3:304
- Ming dynasty, 3:295
- North American indigenous peoples,  
 1:42–43
- rayon, 3:83
- tie-dyeing, 3:325–328
- wool, 3:442
- yarns, 3:457, 458
- yozen, 2:304
- yukata, 3:463
- Dyes, chemical and synthetic,  
**1:387–388**, 3:265, 273
- Dyes, natural, **1:388–390**

## E

- E-commerce, 2:61, 3:102–103
- E! Network, 2:71
- Ear cuffs, 1:394
- Ear piercing. *See* Body piercing
- Earmuffs, 2:192–193
- Earrings, **1:391–395**
- East Africa, 2:297–298
- East Asian dress, **1:82–85**, 2:232–233
- East Indies, 2:241–242, 3:309
- East Turkestan, 1:85
- Easter bonnets, 2:185
- Eastern Europe  
 Communist Dress, 1:287, 288  
 embroidery, 1:409  
 fashion education, 2:42
- Eastern European folk dress, 1:337,  
 2:93, **93–97**, 94, 96
- Eastern fashion  
 Callot sisters, 1:216  
 historical studies of, 2:17  
 influence on European fashion, 1:424,  
 426  
 Liberty & Co., influence on, 2:354
- Eastern Orthodox Church, 1:396
- Ecclesiastical dress, **1:395–400**, 2:442
- Echoform collection, 1:248



- Eckersley, Tom, 3:435
- Economic development, 3:319–320
- Economics and clothing, **1:400–405**  
 globalization, 2:143–145  
 Islamic dress, 2:252–253  
 knitting, 2:308–309  
*See also* Business of fashion; Fashion industry
- Ecuador, 1:46, 46, 3:285
- Ederle, Gertrude, 3:252
- Edie Raymond Locke's Show*, 2:53
- Editors, fashion. *See* Fashion editors
- Edo period, 2:268–269, 304, 3:463
- Education and training  
 fashion models, 2:59  
 Kamali's work with public school students, 2:295  
 window display trade, 3:434  
*See also* Fashion education
- Edward, Prince of Wales. *See* Windsor, Duke and Dutchess of
- Edwardian wigs, 3:430
- Effeminacy  
 gay men, 2:31  
 Macaroni dress, 2:368  
 male dress codes, 2:24  
 morality and, 2:14–15
- Egypt, ancient  
 beads, 1:134  
 beards and mustaches, 1:136  
 Coptic textiles, 3:296–299  
 cross-dressing, 1:320  
 dress in, 1:53, 53–55  
 earrings, 1:391  
 history of dress, 1:17  
 jewelry, 2:278  
 perfume, 3:34  
 prehistoric textiles, 3:307  
 rings, 3:108–109  
 sandals, 3:135  
 tapestries, 3:266  
 tattoos, 3:268  
 textile workers, 3:306  
 underwear, 3:360  
 wigs, 2:161, 3:430
- Egyptian feminism, 2:211, 253
- Eighteenth century  
 actors and actresses, 1:6  
 advertising, 2:27  
 Andean textiles, 3:284–285  
 ballet costumes, 1:115  
 bathing costumes, 3:250–251  
 breeches, 1:194  
 buttons, 1:206–207  
 caricature and fashion, 1:226–228  
 children's clothing, 1:256–257  
 cosmetics, 1:296  
 court dress, 1:312–313  
 earrings, 1:392  
 Empire style, 1:410–411  
 European dress, 1:421, 423  
 fans, 2:6–7  
 fashion illustrators, 2:48  
 fashion magazines, 2:55  
 gloves, 2:146  
 gothic revival, 2:219  
 hairstyles, 2:163  
 handbags and purses, 2:170–171  
 high heels, 2:204–205  
 identity, 2:34–35  
 lace, 2:326  
 London fashion, 2:361  
 Macaroni dress, 2:367–368  
 masquerade and masked balls, 2:393  
 matching jewelry sets, 2:442  
 maternity dress, 2:395  
 men's hats, 2:179  
 mourning dress, 2:425  
 needle production, 2:448  
 neoclassicism, 2:220  
 outerwear, 3:8–9  
 quilted clothing, 3:74–75  
 ribbons, 3:106–107  
 rings, 3:110  
 secondhand clothes, 3:154  
 textile workers, 3:320  
 theatrical costumes, 3:322–323  
 waistcoats, 3:409  
 watches, 3:410  
 wig makers, 2:160  
 wigs, 3:430  
 women's hats, 2:183  
 women's shoes, 3:174–175
- Eisenhower jacket, 2:410
- El Monte, California, 3:249
- Elamite dress, 2:248
- Elastomers, **1:405**
- Electric and magnetic garments, 2:44
- Electric Plaid, 3:273
- Electrostatic flocking, 2:90
- Elf-Sanofi, 3:133
- Elisabeth, Comtesse Greffulhe, 3:61–62
- Eliseeva, V. A., 3:125
- Elizabeth, Queen Mother, 1:326, 2:176, 176–177, 413
- Elizabeth I  
 donated clothing, 3:84–85  
 fans, 2:5  
 lockets, 2:444  
 pearl necklaces, 2:442  
 royal dress, 3:116  
 wigs, 2:159
- Elizabeth II, 3:118  
 Amies, Hardy, designs by, 1:49, 50  
 coronation robes, 3:112–113  
 crown, 1:325  
 Hartnell, Norman, designs of, 2:177  
 Somerville design for, 3:116
- Ellis, Havelock, 1:322–323, 2:459
- Ellis, Perry, **1:405–407**  
 Delaunay, Sonia, influence of, 1:352  
 fashion of, 1:406  
 polyester, 3:53
- Embedded sensors, 3:273
- Embellishments  
 Central Asian dress, 1:78  
 Dior's use of, 1:367–368  
 spangles, 3:202–203  
 Vionnet, Madeleine, 3:403–404
- Emberton, Joseph, 1:362
- Embroidery, **1:407–410**  
*agbada*, 1:31, 32  
 Buddhist images, 3:294  
 Byzantine Empire, 3:287  
 Central American and Mexican dress, 1:40  
 Central Asian textiles, 3:291  
 Central European folk dress, 2:95  
 domestic production, 1:374  
 ecclesiastical dress, 1:396, 396  
 Galanos, James, 2:124  
 Hartnell, Norman, 2:177  
 Inuit and arctic footwear, 2:248  
 Inuit parka, 2:244  
 Japanese textiles, 3:301  
 Lesage, François, 2:350–351  
 Mandarin Squares, 1:264, 265  
 North African dress, 1:18  
 Schiaparelli, Elsa, 3:146  
 trimmings, 3:338  
 Turkmenistan, dress of, 1:81  
 Uzbek bridal clothes, 1:80  
 Vionnet, Madeleine, 3:404
- Emery, Irene, 3:421–422
- Emmanuel, David and Elizabeth, 1:363, 3:11
- Empire-line dresses  
 Ming dynasty, 1:264  
 Tang dynasty, 1:261, 262–263
- Empire style, **1:410–411**, 425, 426, 3:272
- Employment  
 of African Americans, 1:359  
 apparel industry, 3:84, 86–87  
 Balenciaga, House of, 1:109  
 department stores, 1:362  
*See also* Garment trade and garment workers; Labor issues; Textile workers
- The Empress of China* (merchant ship), 3:86
- EMUs (Extravehicular Mobility Units), 3:202
- Endangered and extinct species  
 feathers, 2:74  
 fur industry, 2:116
- Engagement rings, 3:109
- England. *See* Great Britain
- The Englishwoman's Domestic Magazine*, 1:291, 2:55, 3:328
- The Enlightenment  
 armor, 1:71  
 buttons, 1:208
- Entertainment  
 integrated into fashion, 2:117  
 masks, 2:388–389
- Entry suits, 3:59
- Entwistle, Joanne, 2:20

- Environmental issues  
 burial shrouds, 3:182  
 eco-friendly fibers, 2:208  
 fur, 2:116
- Enonism, 1:323
- Equestrian costumes, **1:411–414**  
 boots, 1:174  
 breeches, 1:194  
 coats, 1:273  
 greatcoats, 3:9  
 hats, 2:179  
 Japanese, 2:266  
 riding coats, 1:273, 3:217  
 tailored suits, as predecessor of, 3:259
- Eric, 2:49, 67
- Erman, 3:414
- Ernst, Max, 3:435
- Eroticism  
 Bourdin, Guy, 1:178  
 brassieres, 1:191  
 Comme des Garçon, 1:285  
 corsets, 2:132  
 cross-dressing, 1:322  
 footbinding, 2:107–109  
 Newton, Helmut, 2:454  
*pagnes*, 3:11–12  
 purses, 2:170  
 stockings, 3:224–225  
 underwear, 3:360, 361
- Erté  
 caricature, 1:229  
 fashion illustration, 2:49  
 Poiret, Paul and, 3:47, 348
- Esparza, Ramon, 1:254
- Esquire* (magazine), 2:67
- Esteban, Paulino, 2:308
- Ethiopia, 1:431
- Ethnic dress, **1:414–416**  
 cosmetics, 1:292–295  
 hats, 2:184  
 headbands, 2:192  
 sarongs, 3:141  
 South America, 1:45–49  
*See also* Folk dress; Traditional dress
- Ethnic profiling, 2:253
- Ethnic style, **1:417–418**  
 embroidery, 1:409  
 Grès, Madame, elements used by, 2:152  
 India, 3:310  
 necklaces, 2:442–443  
*pagnes*, 3:11  
 Sub-Saharan African dress, 1:19–20
- Ethnicity. *See* Race/ethnicity
- Ethno-religious groups, 3:98–99
- Ethnography  
 folk dress, 2:93, 97  
 photography, 3:31
- Etiquette  
 ballroom dress, 1:335  
 glove wearing, 2:146, 147  
 hats, 2:412  
 mourning dress, 2:425–426  
 tea gowns, 3:271  
 travel fashion, 3:334  
 underwear, 3:360–361
- Etiquette, and the Usages of Society* (Willis), 1:335
- Etro, 3:43
- Etruscan dress  
 bracelets, 1:184  
 earrings, 1:391  
 overview, 1:57
- Eugenics, 2:458–459
- Eugénie, Empress, 3:447
- Eula, Joe, 2:49
- Eurasian ethnic dress, 1:416
- Europe  
 striped cloth, 3:229  
 sumptuary laws, 3:197  
 tailoring, 3:261–263  
 tapestries, 3:266  
 theatrical costumes, 3:322–323  
 velvet, 3:394  
*See also* Central Europe; Eastern Europe
- European dress, **1:418–427**, 421, 423  
 Andean dress, influence on, 3:284–285  
 armor, 1:69–70  
 art nouveau, 1:76  
 in Australia, 1:101–102  
 batik, 1:130  
 Baudrillard on the three stages of, 1:132–134  
 calico, 1:214–215  
 capes, 3:7–8, 9  
 chintz, 1:267  
 court dress, 1:312–313  
 crochet, 1:318  
 crowns and tiaras, 1:324–326  
 diplomatic uniforms, 3:362–363  
 earrings, 1:391–392  
 embroidery, 1:407–408  
 ethnic, 1:416  
 fans, 2:5–8  
 fashion education, 2:42  
 felt, 2:76  
 helmets, 2:196  
 individual and self, 2:26  
 jewelry, 2:280–283  
 Jewish dress, 2:287–288  
 knitting, 2:309  
 legal and judicial costume, 2:346–348  
 men's shoes, 3:171–172  
 military uniforms, 3:364–368  
 modernism and jewelry, 2:283  
 occupational uniforms, 3:369–372  
 peasant dress, 2:17  
 Roma, 3:114  
 royal and aristocratic dress, 3:116–120  
 Russian dress, influence on, 3:124–125  
*sapeurs*, 3:137  
 shawls, 3:161  
 South Asian dress, influence on, 1:87–88  
 Spanish dress and, 3:205  
 subcultures, 3:232–233  
 teenage fashion, 3:275  
 turbans, 3:344  
 underwear, 3:360–361  
 used clothing, 3:85  
 women's shoes, 3:174  
*See also* Eastern European folk dress; Northern European folk dress; Western European dress and fashion
- EVA (Extra-Vehicular Activity) suits, 3:200–201
- Evangelista, Linda, 2:401, 3:243
- Evans, Caroline, 2:20
- Evansky, Rose, 2:161
- Evening bags  
 Leiber, Judith, 2:349  
 seventeenth century, 2:170
- Evening dress, **1:428–430**, 429, 430  
 Amies, Hardy, 1:49  
 art nouveau, 1:76  
 Balenciaga, Cristóbal, 1:111  
 ball dresses, 1:112–114  
 Beene, Geoffrey, 1:140  
 Chanel, Gabrielle (Coco), 1:249–250, 253  
 De La Renta, Oscar, 1:350–351  
 dress shirts, 1:383  
 Galanos, James, 2:123–124  
 James, Charles, 2:258–259  
 Mainbocher, 2:374  
 New Look, 2:452  
 1910s, 3:348  
 1920s, 3:349  
 1980s, 3:353  
 Windsor, Duchess of, 3:438
- L'éventail* (Uzanne), 3:384
- Ewe weaving, 3:260, 280, 299
- Excelsior drafting system, 1:358
- Exhibitionism, 2:91
- Exhibits  
 Alaïa, Azzedine, 1:33  
 Art Deco, 1:77–78  
 Beene, Geoffrey, 1:141–142  
 Biba, 1:154  
 Callot sisters, 1:216  
 Capucci, Roberto, 1:222  
 Chinese textiles, 3:295–296  
 Coptic textiles, 3:297–298  
 costume jewelry, 1:302–303  
 Delaunay, Sonia, 1:352  
 Demorest, Madame, 1:358–359  
 Exposition International des Arts Décoratifs et Industriels Moderne, 3:349  
 fashion dolls, 2:38  
 fashion history, 2:19–20  
 fashion museums and collections, 2:60–61  
 Ferragamo shoes, 2:79  
 First Ladies' gowns, 2:86–87  
 Galanos, James, 2:124  
 Great Exhibition (1851), 1:11–12

- Hawes, Elizabeth, 2:191  
 Hilfiger, Tommy, 2:214  
 Horst, Horst P., 2:225–226  
 Hoyningen-Huene, George, 2:229  
 International Contest of Hat Designers, 2:185–186  
 International Exhibition (1862), 1:12  
 Italian fashion, 2:256  
 James, Charles, 2:259  
 Japonisme, 2:265  
 Kawakubo, Rei, 1:285  
 Lanvin, Jeanne, 2:332  
 Lesage, François, 2:351  
 McQueen, Alexander, 2:400  
 Miyake, Issey, 2:420  
 Museum of Costume, 2:422  
 Newton, Helmut, 2:454  
 Norell, Norman, 2:457  
 Orientalism, 3:6  
 Ottoman Empire dress, 2:406  
 Penn, Irving, 3:31  
 Rabanne, Paco, 3:78–79  
 rayon, 3:82  
 Rhodes, Zandra, 3:105  
*Romantic and Glamorous: Hollywood Style*, 2:221  
 Russian dress, 3:126  
 Russian textiles, 3:125  
 Saint Laurent, Yves, 3:132–133  
 Spanish fashion, 3:206  
 tiaras, 1:327  
 Toledo, Isabel and Ruben, 3:331  
 Vreeland, Diana, 3:407  
 wearable art, 3:414  
*See also* Museums
- Exoticism**  
 Callot sisters, 1:216  
 colonialism, 1:279  
 cosmetics, 1:293  
 costume jewelry, 1:302–303  
 ethnic style, 1:417  
 folklore look, 2:102  
 Galliano, John, 2:125  
 historical studies of fashion, 2:17  
 Liberty & Co., 2:353–354  
 swimwear, 3:254  
 women's shoes, 3:176
- Exports.** *See* Trade
- Exposition International des Arts Décoratifs et Industriels Moderne, 1:259, 3:216, 301
- Exter, Alexandra, 1:286, 2:119, 3:126
- Extra-Vehicular Activity (EVA) suits, 3:200–201
- Extravehicular Mobility Units (EMUs), 3:202
- Extreme fashions, **1:430–432**
- Eyeglasses, **1:432–434**
- Eyeliners, 2:238
- Eyewear, 3:239–242
- F**
- Fabric display screens, 3:273
- Fabrics. *See* Textiles
- Facial augmentation, 2:233–234
- Factor, Max, 2:221
- Factoring, 1:404
- Fading, 1:308
- Fads, **2:1–2**
- Fair Isle knitting, 2:309
- Fairchild, E. W., 3:439
- Fairchild, John  
 editorial slant, 2:54  
 hemlines, 2:85  
 influence on fashion scene, 2:56  
*Women's Wear Daily*, 3:439–440
- Fairchild Publications, 3:439–440
- Faithful, Marianne, 2:401
- Fake fur, 2:116
- Fake logos, 2:217, 361
- Falchi, Carlos, 2:172
- Fame* (musical), 1:340
- A Family Album* (Duke of Windsor), 3:436–437
- Fan magazines, 2:222
- Fan Museum, 2:60
- Fancy dress, 2:3, **3–5**, 4  
*See also* Ball dress
- Fanni, Vincenzo, 2:118
- Fans, **2:5–8**, 6, 7
- Farley, Lillian, 3:23
- Farmer's wife, 2:9–10
- Farthingales, 3:191
- Fascist and Nazi dress, **2:8–12**, 10
- Fashion, 2:12–13**  
 apparel/fashion distinction, 2:50  
 colors, 1:282–283  
 as cultural construction, 3:232  
 origins, 1:419  
 pajamas as, 3:13–16  
 religion's rejection of, 3:96  
 style/fashion distinction, 2:83  
 terminology, 1:401
- Fashion, attacks on, **2:13–16**
- Fashion, historical studies of. *See* Historical studies of fashion
- Fashion, Photography of the Nineties* (Richardson, Nickerson and Wakefield), 2:203
- Fashion, Theories of. *See* Theory of fashion
- Fashion advertising. *See* Advertising
- Fashion and homosexuality. *See* Homosexuality and fashion
- Fashion and identity. *See* Identity.
- Fashion and Textile Museum, 3:105
- Fashion Center Business Improvement Center (BID), 3:156
- Fashion criticism, 2:190
- Fashion designers, **2:35–38**  
 copied collections, 2:51  
 copying, 3:103–104  
 costume designer/fashion designer distinction, 2:83  
 education, 2:41–43  
 Fairchild, John and, 3:439–440
- fashion dolls, 2:38, 39
- fashion industry and, 2:51–52
- Indian, 2:239–240
- Japanese, 2:262*t*, 263, 264*f*, 265
- logos, 2:360–361
- Madonna's collaborations with, 2:371–372
- Spanish, 3:206
- studies on, 2:20
- t-shirts, 3:343
- transformation of fashion, 2:26
- underwear design, 3:362
- vanity Web sites, 2:61  
*See also* Specific designers
- Fashion dolls, **2:38–40**, 39, 2:73
- Fashion editors, **2:40–41**  
 editorial slant, 2:54  
 Mainbocher, 2:372–373, 374  
*Vogue*, 3:405  
 women, 2:55  
*Women's Wear Daily*, 3:439–429  
*See also* Specific editors
- Fashion education, **2:41–43**  
 haute couture, 2:187  
 Muir, Jean, 2:429  
*See also* Education and training
- Fashion eyewear, 1:433–434
- Fashion Fair, 1:299
- Fashion Group. *See* FGI
- Fashion, health, and disease. *See* Health aspects of dress and fashion
- Fashion icons, **2:46–48**, 2:371  
*See also* Trendsetters
- Fashion illustrators, **2:48–50**  
 advertising posters, 2:28  
 fashion plates, 2:65–67  
*Godey's Lady's Book*, 2:148, 2:149  
*See also* Fashion plates; Specific illustrators
- Fashion industry, **2:50–52**  
 fashion leadership, 2:24–25  
 gay men in, 2:32  
 India, 2:239–240  
 Scotland and, 3:149  
 Seventh Avenue, 3:157  
 street style, 2:118  
 Uzanne, Octave, writing of, 3:385  
*See also* Business of fashion; Economics and clothing; Garment trade and garment workers
- Fashion Institute of Technology  
 Beene, Geoffrey, honoring of, 1:141  
 establishment of, 2:36
- Fashion Institute of Technology Museum, 2:60–61
- Fashion Is Spinach* (Hawes), 2:190
- Fashion journalism, **2:52–54**, 70–71
- Fashion leaders and followers, 2:23
- Fashion magazines and publications, **2:54–56**  
 art nouveau, 1:76  
 Barbier's illustrations, 1:124  
 best-dressed lists, 1:152



- Fashion magazines and publications  
*(continued)*  
 China, 1:266  
 Demorest, Madame, 1:358, 359  
 early, 2:48  
 editorial slant, 2:54  
 evening dress, 1:428  
 first, 2:13  
 Nineteenth century, 1:426  
 Paris fashion, 3:20  
 patterns and, 3:26–27  
 Spain, 3:206–207  
 trendsetters, 3:335  
*See also* Specific titles
- Fashion marketing and merchandising.  
*See* Marketing
- Fashion models, **2:58–60**  
 African American, 3:337  
 Avedon, Richard, choices of, 1:105, 2:64  
 body ideals, 2:130  
 Bourdin, Guy, treatment by, 1:178  
 Capucci's opposition to supermodel phenomenon, 1:222  
 celebrity, 2:65  
 Dior, House of, 1:367–368  
 diversity, 2:65  
 of Dolce & Gabbana, 1:371  
 fashion television, 2:71  
 first use of, 2:68  
 heroin chic, 2:202–203  
 McQueen, Alexander, choices of, 2:400  
 Meisel, Steven, choices of, 2:401  
 Patou's importing of American models, 3:23  
 photographic/runway distinction, 2:69  
 supermodels, 3:242–244  
*See also* Supermodels; Specific models
- Fashion museums and collections, **2:60–61**
- Fashion Nation, 1:145–146
- Fashion newsreels, 2:68–69
- Fashion online, **2:61–62**
- Fashion philosophy  
 Balenciaga, Cristóbal, 1:110–111  
 Beene, Geoffrey, 1:142  
 dandyism, 1:343  
 Dior, Christian, 1:367–368  
 Gernreich, Rudi, 2:137  
 James, Charles, 2:259  
 Steele, Lawrence, 3:222  
 Vionnet, Madeleine, 3:401–402  
 Yamamoto, Yohji, 3:454–455  
*See also* Theory of fashion
- Fashion photography, **2:62–65**, 63  
 fashion illustration, impact on, 2:48  
 fashion plates, 2:67  
 heroin chic, 2:203  
 makeup artists, 2:374–375  
 Paris fashion, 3:20  
*See also* Specific photographers
- Fashion plates, **2:65–67**  
*Godey's Lady's Book*, 2:148, 2:149  
 illustrators, 2:48–49  
 tea gowns, 3:272  
*See also* Fashion illustrators
- Fashion schools, 2:36
- Fashion shows, **2:67–70**, 68  
 China, 1:266  
 Fontana sisters, 2:104  
 Galliano, John, 2:124, 125  
 Italian fashion, 2:254  
 McQueen, Alexander, 2:399–400  
 Moschino, Franco, 2:424  
 Moscow, 1:288  
 music, use of, 1:34  
 origins, 1:402  
 Paris fashion, 3:19–20  
 press coverage, 2:52–54  
 Schiaparelli, Elsa, 3:146  
 stage *vs.* runway, 2:53  
 Steele, Lawrence, 3:222  
 theatrical makeup, 3:325  
 Versace, Donatella, 3:396  
 Viktor & Rolf, 3:398  
 Xuly, Bët, 3:451–452
- Fashion systems model of fashion theory, 2:21
- Fashion television, **2:70–71**
- Fashion textiles, 3:302
- Fashion tours, 2:68
- Fashion victims, 2:2
- Fashion Week of the Americas, 2:335
- Fashionista*, 2:335
- Fassett, Kaffe, 2:310
- Fasteners, **2:71–72**  
 activewear, 1:4  
 Gaultier, Jean-Paul, 2:128
- Fat grafting, 2:233–234
- Fath, Geneviève, 2:72, 74
- Fath, Jacques, **2:72–74**, 73  
 Bettina and, 2:69  
 cocktail dresses, 1:275  
 Givenchy, Hubert de, apprenticeship of, 2:141  
 haute couture, 2:187  
 Les Couturiers associés, 2:188  
 1950s fashion, 3:350  
 Paris fashion, 3:20
- Faux naives* fashion plates, 2:67
- Feathers, **2:74–75**  
 ceremonial costumes, 1:245  
 Demeulemeester, Ann, 1:353  
 fans, 2:5  
 hair adornment, 2:159  
 trimmings, 3:338  
 twining, 3:307–308
- Fede rings, 3:109
- Federal Trade Commission  
 fiber categories, 3:81–82  
 labeling laws, 2:319–320  
 olefin classification, 3:3
- Felix, 2:62
- Fellowes, Daisy, 3:147
- Felt, **2:75–76**
- Felt hats, 2:178
- Felting  
 beaver fur, 2:115  
 Central Asian textiles, 3:289, 290  
 shrinkage, 3:32  
 wool, 3:443
- Female impersonators. *See* Cross-dressing
- Femininity  
 Barbie, 1:122–123  
 bodybuilding and sculpting, 1:165  
 children's clothing, 1:259  
 cross-dressing, 1:322  
 Fogarty, Anne, designs of, 2:92  
 footbinding, 2:106  
 future of fashion, 2:117  
 Gaultier, Jean-Paul, 2:128  
 goths, 2:151  
 lace, 2:326  
 Lanvin, Jeanne, 2:332  
 lesbians, 2:32  
 lingerie, 2:356–357  
 New Look, 2:452  
 Saint Laurent, Yves, 3:133  
 theory of fashion, 2:24
- Feminism  
 bloomerism, 1:381–382  
 bra-burning myth, 1:192  
 cosmetics, criticism of, 1:299  
 Cunningtons' history of dress, 1:329  
 dress reform, 2:15  
 Egyptian, 2:253  
 embroidery and, 1:374  
 gender and dress, 2:133  
*bijab*, 2:211–212  
 1970s fashion, 3:351  
 nudity, 2:461  
 radical, 2:32  
 tailored suits, 3:259  
 veils, 3:393–394
- La Femme à Paris* (Uzanne), 3:385
- Fendi, **2:76–78**, 77  
 accessories, 2:127  
 handbags, 2:169, 2:172, 173  
 hip-hop style, 2:216  
 Lagerfeld, Karl, 2:328  
 leather, 2:345  
 logo, 2:361
- Fenton, Joyce, 2:429
- Ferguson, Rosemary, 2:203
- Ferragamo, Salvatore, **2:78–80**  
 costume design, 2:221–222  
 Italian fashion, 2:254  
 platform shoes, 2:177
- Ferré, Gianfranco  
 Dior, House of, 1:368  
 Italian fashion, 2:255
- Ferretti, Alberta, 2:372
- Ferri, Fabrizio, 1:372
- Ferry, Bryan, 2:433
- Festival costumes. *See* Ceremonial and festival costumes
- Fetish fashion, 2:80, **80–81**  
 corsets, 1:292  
 cross-dressing, 1:322

- footbinding, 2:107–109  
 fur, 2:116  
 high heels, 2:204  
 Mugler, Thierry, 2:428  
 Feudal society, 1:419  
 Fez, 2:293  
 FGI (Fashion Group International), 3:57  
 Fiber artists, 1:319  
 Fiber K, 2:140  
 Fiber-reactive dyes, 1:388  
 Fibers, **2:81–82**  
   acrylic and modacrylic, 1:2–3  
   alpaca, 1:36–37  
   angora, 1:59  
   camel hair, 1:218  
   cashmere and pashmina, 1:233–236  
   cotton, 1:306–309  
   felt, 2:75–76  
   flock, 2:90  
   hemp, 2:200–201  
   mohair, 2:421  
   nylon, 2:461–462  
   olefin, 3:3  
   ramie, 3:81  
   rayon, 3:81–84  
   silk, 3:182–184  
   Southeast Asian textiles, 3:314–315  
   spinning, 3:210  
   techno-textiles, 3:272–273  
   technological developments, 2:207–208  
   *toosb*, 1:235  
   wool, 3:441–443  
   *See also* Textiles  
 Fibulas, 1:195–196  
 Fidfad, 2:1, 2  
 Fields, Patricia, 3:399  
 Fiestas, 1:41  
 Fifteenth century  
   breeches, 1:193  
   legal and judicial costume, 2:346  
*The Fifth Element* (film), 2:84  
*Fifty Years of Fashion* (Steele), 3:459  
 Figure skating, 3:186–188  
 Filament yarns, 3:456  
 Film and fashion, **2:82–86**  
   actors and actresses, 1:5–6  
   Adrian, 1:10–11  
   art deco, 1:77–78  
   *Beau Brummell*, 1:200  
   caricature, 1:229  
   Cashin, Bonnie, 1:232  
   Chanel, Gabrielle (Coco), 1:252  
   costume design, 1:300–301  
   dance and, 1:335–336  
   Dior, Christian, 1:366, 367  
   distressing, 1:369  
   flappers, 2:89  
   Givenchy, Hubert de, 2:141  
   Head, Edith, 2:192  
   Italian fashion, 2:254  
   Japanese fashion, influence on, 2:262  
   jeans, 2:273–274  
   Levi Strauss, 2:353  
   lipstick, 2:358  
   little black dress, 2:358, 359  
   nail polish, 2:437  
   Norell, Norman, 2:457  
   Orientalism, 3:6–7  
   pajamas, 3:13, 3:14  
   Rabanne, Paco, 3:78  
   sarongs, 3:141–142  
   stockings, 3:224, 225  
   sunglasses, 3:241  
   swimwear, 3:250  
   t-shirts, 3:342  
   tuxedos, 3:345  
   Valentina, 3:387–388  
   women's trousers, 3:220  
   *See also* Actors and actresses; Costume design; Hollywood style; Theatrical costumes  
 Filmer, Naomi, 2:399  
 Final Home, 1:4  
 Finishes  
   cotton, 1:307–308  
   crepe, 1:316  
   glazing, 2:142–143  
   Steele, Lawrence, 3:222  
   technological innovations, 2:208  
   wool, 3:442  
 Finkelstein, Joanne, 1:379  
 Finnish fashion, 2:383–385  
 Fiorucci jeans, 2:274  
 Fire helmets, 2:197  
 Firefighters' clothing, 3:59  
 First Ladies' gowns, **2:86–87**, 87  
 First Nations, 2:116  
 Fischel, Oscar, 2:18  
 Fish skins, 2:245  
 Fishermen  
   guernseys, 2:309  
   oilskins, 3:2  
 Fitness fashion  
   leotards, 2:350  
   1980s, 3:352–353  
 Fitted garments, 2:235–236  
 Fittings  
   costume design, 1:302  
   cutting and, 1:330  
 Fitz-Simon, Stephen, 1:116, 153–154  
 Fitzgerald, F. Scott, 2:89  
 Five pillars of Islam, 2:251  
 Flame resistance  
   finishes, 3:33  
   wool, 3:443  
 Flammable Fabrics Act, 2:319  
 Flannel, **2:87–88**  
   grunge, 2:154  
   napping, 2:439–440  
 Flanner, Janet, 2:226  
 Flappers, **2:88–89**, 89  
   girdles, 2:138  
   hair bobbing, 2:164, 165  
   teenage fashion, 3:275  
 Flat bed silk-screening, 1:387  
 Flat garments, 2:381–382  
 Flemish laces, 2:325  
 Flip-flops, 3:136–137  
 Flocking, **2:90**  
 Floge, Emilie, 3:413  
 Floor looms, 2:363–364  
 Flowers  
   costume jewelry, 1:304  
   daisy motif, 1:309  
   hair adornment, 2:159, 195  
   rose motif, 3:404  
   trimmings, 3:338  
   wedding costumes, 3:427  
 Flüeler, M. Augustina, 1:398  
 Flügel, J. C., **2:90–92**  
   Cunnington, C. Willett, compared to, 1:328  
   Langley Moore, Doris, criticism by, 2:19  
   men's dress, 3:237  
   psychology of fashion, 2:18  
   skirts, 3:190  
   underwear, 3:361  
 Flyboys, 2:216  
 Flyer spinning wheels, 3:210  
 FNAC, 3:133  
 Foale and Tuffin, 3:459, 460–461, 462  
 Fogarty, Anne, 1:275, **2:92–93**  
 Fokine, Michel, 1:115  
 Folding fans, 2:5–6  
 Folk dress, **2:93–97**, **97–102**  
   Central American and Mexican dance costumes, 1:40  
   cowboy dress, 1:315  
   dance costumes, 1:337–338  
   Eastern European, 2:93, 94, 96  
   ethnic dress, 1:414  
   fascist and Nazi dress, 2:9–11, 10  
   Gernreich, Rudi, elements used by, 2:136  
   hats, 2:184  
   hippie style and, 2:218  
   Russia, 1:286  
   Western European, 2:97, 99, 101  
   *See also* Rural dress  
 Folklore look, **2:102–104**, 103, 3:351, 352  
 Folkwear (company), 2:103  
 Fonssagrives-Penn, Lisa, 2:64, 3:31  
 Fontana sisters, **2:104–106**  
   fashion of, 2:105  
   Italian fashion, 2:254  
 Fontange, 2:163, 182–183, 3:125  
 Fonteyn, Margot, 1:271  
 Football (American), 3:382  
 Football (soccer)  
   fashion and, 1:239–240  
   uniforms, 3:378–380  
 Footbinding, 1:431, **2:106–109**, 107, 2:132  
 Footwear  
   ancient world, 1:52  
   Ferragamo, Salvatore, 2:78–80  
   footbinding, 2:106–109, 107

- Footwear (*continued*)  
 Inuit and arctic, 2:246–248  
 Korean women, 2:314  
 Sub-Saharan Africa, 1:23–24  
*See also* Boots; High heels; Sandals;  
 Shoemaking; Shoes
- Forain, Cham and J. L., 1:228
- Ford, Tom, 2:109, **109–110**  
 celebrities, use of, 1:240  
 Gucci, 2:156  
 handbags, 2:173  
 1990s fashion, 3:353  
 Paris fashion, 3:20  
 Saint Laurent, Yves, 3:133  
 t-shirts, 3:343
- Ford modeling agency, 2:59, 69
- Forecasting, color, 1:283
- Fores, Samuel W., 1:226
- Forgeries. *See* Counterfeit logos
- Formal business dress, 1:237
- Formal wear, men's, **2:110–112**, *111*,  
*112*, 3:345, 438
- Forster and Son, 3:436–437
- Fortuny, Mariano, **2:113–114**  
 aesthetic dress, themes of, 1:14  
 artistic dress, 3:413  
 ethnic style, 1:417  
 Italian fashion, 2:254  
 neoclassicism, 2:220  
 Orientalism, 3:5  
 Poiret, Paul, influence of, 3:348  
 reform style, 1:382
- Fossilized fashion  
 golf clothing, 2:150  
 religion and dress, 3:95, 98
- Foster, Joseph W., 3:196, 214
- Foulard, 3:420
- Four-in-hand. *See* Long ties
- Fourrure*, 2:58
- Fox, Charles James, 2:367
- Fox, Frederick, 2:412
- Fox, George, 1:381
- Fox-trot dress, 1:339
- Foy, René, 1:326
- Fraga, 2:335
- La Française du siècle* (Uzanne), 3:384–385
- France  
 actors and actresses, 1:6  
 Baroque period, 1:424  
 Benjamin on social aspects of French  
 fashion, 1:147–148  
 Bertin, Rose, 1:151–152  
 bohemian dress, 1:170–172  
 button production, 1:206–207  
 caricature and fashion, 1:227  
 colonialism, 1:84, 95  
 court dress, 1:312–313  
 cross-dressing, 1:322  
 crowns, 1:324–325  
 cultural aspects of fashion, 2:24  
 dandyism, 1:341–343  
 Empire style, 1:410–411  
 equestrian costume, 1:412, 413–414  
 fans, 2:7, 8  
 farthingales, 3:191  
 fashion dolls, 2:38, 39  
 fashion education, 2:42  
 fashion in literature, 1:118–119  
 fashion plates, 2:66  
 folk dress, 2:99  
 hairstyles, 2:160  
 high heels, 2:204–205, *205*  
 historical studies of fashion, 2:17–18  
 jewelry, 2:281–282  
 lace, 2:325  
 legal and judicial costume, 2:346–348  
 Marist Brothers, 1:397–398  
 masquerades, 2:3  
 men's shoes, 3:172  
 military uniforms, 3:366–368  
 mourning dress, 2:426  
 nobility, 1:402  
 Orientalism, 3:5–6  
 perfume, 3:35–36  
 promotion of national products, 1:401  
 Republican Guard, 3:363  
 ribbons, 3:106–108  
 Rococo style, *1:421*  
 shawls, 3:161  
 sociology of fashion, 1:127–128  
 tea gowns, 3:271–272  
 umbrellas, 3:357–358  
 Uzanne, Octave, writing of, 3:384–385  
 Vietnamese dress, influence on,  
 1:61–62, 84  
 women's shoes, 3:174–176  
*See also* Paris fashion
- France Télécom, 3:273
- Franchising, 1:188
- Fratini, Gini, 1:363
- Frederick II, 3:370
- Frederick's of Hollywood, 2:121, 357
- Free-trade agreements  
 Latin America, 2:335  
 textile trade, 3:319–320, 321
- Freedom dress, 1:161
- Freedom of expression, 3:50, 376
- Freeze branding, 1:186
- French aviation coats, 3:80
- French Revolution  
 Bertin, Rose, 1:151  
 court dress, 1:313  
 Empire style, 1:410  
*La Française du siècle* (Uzanne),  
 3:384–385  
 jewelry market, 2:282
- French *Vogue*, 2:65, 454
- Friction spinning, 3:456
- Friezed textiles, 3:307
- Fringe  
 Jewish dress, 2:284  
 symbolism, 2:96
- Frissell, Toni, 2:64
- Frith, W. P., 1:14
- Frocks, 1:273, 3:8, 3:9, 348–349
- Fruit of the Loom, 3:341–342
- FTM, 1:34–35
- FUBU, 2:275
- Fuentes, Daisy, 2:71
- Fujiwara, Dai, 2:419
- Fukai, Akiko, 2:61
- Fulham Road Clothes Shop, 3:104
- Full Frontal Fashion* (television show),  
 2:53–54, 71
- Fuller's earth, 1:383
- Fulling, **2:114–115**
- Fulvimari, Jeffrey, 2:49
- The Function of Folk Costume in Moravian  
 Slovakia* (Bogatyrev), 2:95
- Funerary and burial rituals  
 Chinese textiles, 3:293  
 Ghana, 1:242–243  
 Kalabari, 1:242  
 shrouds, 3:180–182  
*See also* Mourning dress
- Funny Face* (film), 2:83
- Fur, **2:115–117**  
 animal prints as alternative to, 1:60  
 coats, 2:428  
 felt, 2:76  
 Fendi, 2:76–78  
 glazing, 2:143  
 Japanese fashion, 2:259–260  
 labeling laws, 2:319  
 Lapland, 2:98  
 muffs, 2:427, 427–428  
 1980s fashion, 3:353  
 North American indigenous peoples,  
 1:44  
 outerwear, 3:7, 9  
 parkas, 3:21  
 Russian dress, 3:123–124  
 sixteenth century, 1:401  
 sumptuary laws, 2:14
- Fusion, 3:103
- Future of fashion, **2:117–118**  
 active protection, 3:60  
 health and dress, 2:45–46  
 techno-textiles, 3:274
- Futurism, **2:118–119**  
 Courrèges, André, 1:309–310  
 Vionnet, Madeleine and, 3:403
- ## G
- G-strings, **2:121–122**
- Gaba, Lester, 2:379
- Gabardine, 1:201, **2:122**, 3:420
- Gable, Clark, 2:84, *3:14*
- Gagné, Mariouche, 2:116
- Galanos, James, 2:123, **123–124**, 3:107
- Galeotti, Sergio, 1:66
- Galitzine, Irene, 3:14
- Gallenga, Monica Monaci, 3:5
- Galleries, art, 1:72
- Gallery of English Costume, 2:60
- Galliano, John, **2:124–126**, *125*  
 art and fashion, 3:414  
 art deco, 1:78



- art nouveau, 1:77  
 camouflage cloth, 1:219  
 caricature, 1:229  
 Clark, Ossie, influence of, 1:269  
 Dior, House of, 1:368, 3:20  
 ethnic style, 1:417  
 Fashion and Textile Museum, 3:105  
 fashion shows, 2:70  
 fetish fashion, 2:81  
 folklore look, 2:103  
 Givenchy, House of, 2:142  
 handbags, 2:173  
 haute couture, 2:189  
 Jones, Stephen and, 2:414  
 knitwear, 2:310  
 lingerie as outerwear, 2:357  
 London fashion, 2:362  
 McQueen, Alexander, compared to, 2:400  
 New Romantics, 2:432  
 1990s fashion, 3:353  
 Oriental belly-dance costumes, influence of, 1:338  
 Orientalism, 3:7  
 perfume, 3:36  
 Rastafarian style, 2:432  
 retro style, 2:221  
 rubber wear, 3:121  
 Scottish textiles, 3:149  
 tweeds, 3:348  
 vanity Web sites, 2:61  
 vintage fashion, 3:400  
 Vionnet, Madeleine, influence of, 3:404  
 Gallitzine, 1:275  
 Gandhi, Mohandas, 2:224  
 Gangs. *See* Street style  
 The Gap, 2:372, 3:101, 383, 420  
 Garbo, Greta, 1:10, 11, 2:221  
 Garçonne  
   1920s fashion, 3:349  
   tailored suits, 3:260  
 Gargush, 2:285  
 Garibaldi shirts, 1:163  
 Garland, Madge, 3:459  
 Garment district. *See* Seventh Avenue  
 Garment trade and garment workers, 2:126–127  
   economics and clothing, 1:403  
   fashion industry, 2:51  
   globalization, 2:144–145  
   labor unions, 2:51, 321–322  
   Latin America, 2:334  
   London, 2:361–362  
   ready-to-wear, 3:88, 88  
   Seventh Avenue, 3:155–157  
   strike at House of Chanel, 1:252  
   sweatshops, 3:247–249  
   Vionnet, Madeleine, employees of, 3:404  
   *See also* Fashion industry  
 Garnier, Guillaume, 2:60  
 Garters, 2:227  
 Gaslight coffee house, 1:171  
 Gasperini, Nicoletta, 1:372  
 Gaster, Owen, 2:432  
 Gates, Henry Louis, Jr., 1:347  
 GATT (General Agreement on Tariffs and Trade), 3:319–320  
 Gattinoni, 3:50  
 Gaucho dress, 1:314, 315  
 Gaultier, Jean-Paul, 2:127–128, 128  
   corsets, 1:292, 3:419  
   costume design, 2:83, 84  
   crochet, use of, 1:319  
   demimonde influence, 1:357  
   embroidery of Lesage, 2:351  
   fashion photography and, 2:65  
   fetish fashion, 2:81  
   film and fashion, 2:85  
   fur fashion, 2:116  
   gay style, 2:32  
   haute couture, 2:189  
   Hermès, 2:202  
   Jones, Stephen and, 2:414  
   knitwear, 2:310  
   Madonna's Blonde Ambition tour costume, 2:371, 372  
   men's fashion, 3:353  
   music and fashion, 2:430  
   New Look, homage to the, 2:451  
   1980s fashion, 3:352  
   1990s fashion, 3:353  
   Oriental belly-dance costumes, influence of, 1:338  
   perfume, 3:36  
   punk, 3:429  
   Rastafarian style, 2:432  
   Scottish textiles, 3:149  
   second skin concept, 2:118  
   soccer and fashion, 1:239  
   suede, 2:345  
   sweaters, 3:245  
   sweatshirts, 3:246  
   t-shirts, 3:343  
   tartan, 3:268  
   unisex clothing, 3:383  
   waistcoats, 3:410  
 Gauntlet shops, 1:167–168  
 Gautreau, Virginie, 2:359  
 Gavarni, Paul, 2:394  
 Gavarni and Deveria, 2:66  
 Gay fashion. *See* Homosexuality and fashion  
 Gayet, Albert, 3:297–298, 299  
*Gazette du bon ton* (magazine), 2:49, 55, 67, 250  
 Gee, Cecil, 3:263  
 Gemini space program, 3:202  
 Gemstones. *See* Jewelry  
 Gender, dress and fashion, 2:128–134  
   Arab dress, 1:369, 2:294  
   attacks on fashion, 2:13–14  
   Barbie, 1:121–123  
   Bloomer costume, 1:161–163  
   bustles, 1:204  
   children's clothing, 1:256–260  
   color symbolism, 1:259  
   Cunningtons' history of dress, 1:329  
   Demeulemeester, Ann, 1:354  
   dress code discrimination, 3:49  
   dress for success, 1:378  
   ethnic dress, 1:414–415  
   female pseudonyms of Mallarmé, Stéphane, 2:377  
   Fogarty, Anne, 2:92  
   fur, 2:115–116  
   gloves, 2:147  
   goths, 2:151  
   India, 2:238–239  
   Latin American fashion, 2:334  
   Macaroni dress, 2:368  
   medieval fashion, 1:420  
   mourning dress, 2:425–426  
   *pagnes*, 3:11  
   pockets, 3:41  
   religion and dress, 3:95–100  
   *salwar-kameez*, 3:134  
   separate spheres theory, 2:24  
   sex *vs.* gender, 2:129  
   skating dress, 3:187–188  
   skirts, 3:190  
   subcultures, 3:234–235  
   trickle-down theory, 3:336  
   trousers, 3:340–341  
   veils, 3:392–394  
   Yamamoto, Yohji, 3:454  
   *See also* Cross-dressing  
 General Agreement on Tariffs and Trade (GATT), 3:319–320  
 Generation X, 2:154  
 Generators, 3:274  
 Genghis Khan, 3:289  
 Genital piercing, 1:167  
 Genius group, 2:276  
 Genroku style, 2:303–304  
 Gentlemanly style, 1:345–346  
 Geofriendly fibers, 2:208  
 Geometric designs  
   Patou, Jean, 3:22  
   George, Dorothy, 2:368  
 George IV, King of England, 2:301, 3:130  
 Geotrophics collection, 1:248  
 Gerber, Marie Callot  
   Japonisme, 2:271  
   Orientalism, 3:5–6  
 Germanic tribes, 2:280  
 Germany  
   armor, 1:70  
   diplomatic uniforms, 3:363  
   fascist and Nazi dress, 2:8–12  
   folk dress, 2:99–100  
   Hugo Boss, 2:229–230  
   needle production, 2:449  
   1930s fashion, 3:350  
   nudism, 2:458  
   occupational uniforms, 3:371–372  
   royal and aristocratic dress, 3:120  
   secondhand clothes, 3:152

- Germany (*continued*)  
 tattoos, 3:270  
 theatrical costumes, 3:323  
 window displays, 3:434
- Gernreich, Rudi, **2:134–137**, 135  
 animal prints, 1:60  
 bikinis, 1:156–157  
 disenchantment of, 2:219  
 Hawes, Elizabeth and, 2:191  
 homosexuality, 2:32  
 leotards, 2:349  
 1960s fashion, 3:351  
 scarves, 3:143  
 swimwear, 3:254  
 thong bikinis, 2:121  
 unisex clothing, 3:383
- Gerre, Gianfranco, 2:189
- GFT, 1:67, 68
- Ghana  
 adinkra cloth, 1:6–8  
 cosmetics, 1:294–295  
 funerary rituals, 1:242–243  
 kente, 2:299–300  
 wrappers, 1:20
- Ghauri, Yasmeen, 3:243
- al-Ghazali, Zaynab, 2:212
- Ghesquière, Nicolas  
 Balenciaga, House of, 1:111  
 handbags, 2:173  
 rubber wear, 3:121
- Ghezzi, Pier Leone, 1:226
- Gbo*, 3:311
- Ghost Dance movement, 1:244
- Giacobbe, Andrea, 1:229
- Gibb, Bill, 3:149
- Gibson, Charles Dana  
 caricature, 1:229  
 fashion illustrations, 2:49  
 shirtwaists, 1:164  
 silhouette of Lily Langtry, 2:46
- Giffo process, 3:77
- Gigi* (Colette), 1:355
- Gigli, Romeo, **2:137–138**  
 Hippie look, 2:433  
 Italian fashion, 2:255
- Gilbert, Eugene, 3:275
- Gill, Angela, 2:429
- Gillette razors, 1:119, 136
- Gillray, James, 1:228
- Gimmel's catalog, 1:164
- Gimmel rings, 3:109
- Ginsburg, Madeleine, 3:154
- Giorgini, Giovanni Battista, 1:34
- Girdles, **2:138–141**, 139, 140
- Girl in a Fur* (Titian), 2:280
- Givenchy, House of  
 accessories, 2:127  
 fashion shows, 3:325  
 Galliano, John, 2:125, 126  
 haute couture, 2:189  
 Madonna and, 2:372  
 McQueen, Alexander, 2:400  
 1990s fashion, 3:353  
 sunglasses, 3:241  
 Treacy, Philip, 2:414
- Givenchy, Hubert de, **2:141–142**, 142  
 caftan style, 1:212  
 costume design, 1:6  
 embroidery of Lesage, 2:350  
 film and fashion, 2:82, 83  
 little black dress, 2:359  
 1950s fashion, 3:350  
 Paris fashion, 3:20  
 perfume, 3:36  
 Rabanne, Paco and, 3:77  
 suede, 2:345  
 Windsor, Duchess of, 3:438
- Glasgow School, 1:408
- Glazing, 1:266, **2:142–143**
- Glen Urquhart tweeds, 3:346
- Global sustainability, 3:90–91
- Globalization, **2:143–145**  
 caftans, 1:212  
 Cardin, Pierre, 1:224–225  
 ecclesiastical dress, 1:398–399  
 fashion industry, 2:52  
 garment trade, 2:126–127  
 hip-hop, 2:215  
 Indian fashion, 2:240  
 labor unions, 2:321  
 Paris fashion, 3:20–21  
 perfumes, 3:36  
 retailing, 3:100  
 shopping, 3:179–180  
 Southeast Asian textiles, 3:317–318  
 sweatshops, 3:249  
 women's trousers, 3:341
- Glossaries  
 calico related terms, 1:213  
 chintz related terms, 1:267  
 gabardine related terms, 2:122  
 recycled textiles related terms, 3:91  
 textile related terms, 3:285, 304, 305  
 tie-dyeing related terms, 3:326
- Gloves, **2:146–147**  
 bicycling, 1:155  
 etiquette, 1:335  
 perfume and, 3:34
- Gluck, Peter, 1:344
- Go-Go boots, 1:175
- Goatees. *See* Beards and mustaches
- Godey's Lady's Book*, 2:55, **147–149**, 148
- Godwin, E. W., 1:12, 2:354
- Goffman, Erving, 1:378
- Golbin, Pamela, 2:60
- Gold Cup Day, 2:185
- Golden Spindle competition, 1:143
- Golden Thimble Award  
 Lacroix, Christian, 2:327  
 Montana, Claude, 2:330
- Goldin, Nan, 2:203
- Goldschmied, Adriano, 2:276
- Goldsmán, Ernst, 3:434
- Goldsmithing  
 Greece, ancient, 2:279  
 Rome, ancient, 2:279–280
- Golf clothing, **2:149–150**, 3:215, 220
- Golovin, A., 3:126
- Goncharova, Natalia, 3:126, 413
- Gone with the Wind* (film), 2:222
- Goodyear, Charles, 3:120, 167, 195
- Gordon, Lady Duff. *See* Lucile
- Gore-Tex. *See* Techno-textiles
- Gortex implants, 2:233, 234
- Gosudarstvenny Universalny Magazin (GUM) department store, 1:361
- Goth* (Hodkinson), 3:236
- Gothic dress  
 aesthetic *vs.* gothic, 2:220  
 armor, 1:70  
 revivals, 2:219–220  
 studies of medieval dress, 2:17
- Goths, **2:150–152**, 151  
 gothic influence, 2:220  
 occult dress, elements of, 3:2  
 subcultures, 3:236
- Goude, Jean-Paul, 2:430
- Gould, Edith, 2:444
- Government fashion control, 3:48, 126
- Gowns  
 China, ancient, 1:261  
 graduates', 1:1–2  
 Italian Renaissance, 1:422–423  
 legal and judicial costume, 2:346–348  
 medieval, 1:422  
 terminology, 3:110
- Gowns of Emotions, 2:365
- Grable, Betty, 1:5, 3:250
- Grace, Princess. *See* Kelly, Grace
- Graduation gowns, 1:1–2
- Graham, Martha, 1:339–340
- Grand boubous, 1:176
- Grand habits, 1:312, 2:380
- Grandassa, 1:25–26, 30
- Les grandes troit*, 1:355
- Grandville, J. J., 1:228
- Granny glasses, 1:434
- Gratitude Train, 2:38
- Gravenites, Linda, 2:218–219
- Gray, H. G., 2:28
- Gray, Miss, 1:50
- Gray, Richard, 2:49
- Great Britain  
 actors and actresses, 1:6  
 aesthetic dress, 1:11–14  
 Barbours, 3:3  
 Baroque period, 1:423–424  
 body piercing legislation, 1:169  
 British invasion, 3:276  
 British Navy, 3:270  
 Brummell, George, 1:199–200  
 button production, 1:207–208  
 caricature and fashion, 1:226  
 children's shoes, 3:170  
 coats, 1:273  
 colonialism, 1:95, 278, 278  
 coronation robes, 3:112–113  
 court dress, 1:312, 313

- cricket uniforms, 3:380  
 cross-dressing, 1:321–322  
 crowns and tiaras, 1:325–326, 327  
 diplomatic uniforms, 3:362–363  
 Empire style, 1:410–411  
 equestrian costume, 1:411–414  
 fashion education, 2:42  
 folk dress, 2:97–98  
 formal wear, 2:111–112  
 fur, 2:116  
 guernseys, 2:309  
 hats, 2:178–180  
 Highland dress, 3:148–149  
 history of dress, 1:328–329  
 Indian textiles, 3:309  
 jewelry, 2:2842–283  
 kilts, 2:301–302  
 legal and judicial costume, 2:346–348  
 Macaroni dress, 2:367–368  
 Marks & Spencer, 2:385–386  
 mechanization of production, 1:402  
 men's shoes, 3:171, 172  
 mourning dress, 2:425–426  
 naval uniforms, 2:440  
 neckwear, 2:444–447  
 needle production, 2:448–449  
 Nehru jackets, 2:450–451  
 prison dress, 3:55–56  
 punk, 3:67–68  
 ready-to-wear, origins of, 1:401–402  
 Royal footmen, 3:371  
 rugby uniforms, 3:380–381  
*sakwar-kameez*, 3:134  
 school uniforms, 3:375  
 scuttlers, 3:275  
 shawls, 3:160–161  
 shoemaking, 3:164–165  
 shrouds, 3:180–181  
 subcultures, 3:233–234, 235–236  
 sumptuary laws, 3:173–174  
 tartan, 3:267–268  
 tattoos, 3:269–270  
 tea gowns, 3:271–272  
 Teddy boys, 2:220  
 textile trade, 3:318  
 tweeds, 3:346–347  
 umbrellas, 3:358–360  
 working-class dress, 3:445–446  
 zipper manufacturing, 3:466  
*See also* London fashion
- Great Depression  
   girdles, 2:138–139  
   revival of historical styles, 3:6  
 Great Exhibition (1851), 1:11–12  
 Great Plains, 1:244  
 Great wheel, 3:210  
 Greatcoats, 1:273, 3:8, 9  
 Greece, ancient  
   beards and mustaches, 1:136  
   cross-dressing, 1:321  
   crowns and tiaras, 1:324, 325  
   dress, 1:55–57  
   earrings, 1:391
- Fortuny, Mariano, influence on, 2:113  
 hairstyles, 2:162  
 jewelry, 2:278–279  
 sandals, 3:135, 169  
 South Asian dress, influence on, 1:86  
 theatrical costumes, 3:322  
 wedding costumes, 3:426
- Greek folk dress, 2:98, 100  
 Greek Orthodox church, 2:195  
 Green, 2:406  
 Green, Rupert Lycett, 3:143, 263  
 Green Earth dry cleaning process, 1:384  
 Green Flash shoes, 3:195  
*The Green Hat* (Arlen), 1:123–124  
 Greenaway, Kate, 2:220  
 Greenland, 2:246, 248  
 Greenwich Village, 3:413  
 Grès, Madame (Alix), 2:152–153  
   celebrity, 2:51  
   embroidery of Lesage, 2:350  
   Orientalism, 3:6  
 Griffe, Jacques, 2:350  
 Gripper machines, 3:424  
*Grisettes*, 1:355  
 Grosz, Georg, 1:228  
 Group norms, 3:99  
 Gruau, René, 2:49  
 Grunge, 1:407, 2:153, 153–155  
 Guard armor, 1:70  
 Guardees, 2:432  
 Guardian Angels, 1:150  
 Guayabera, 2:336  
 Gucci, 2:155, 155–156  
   accessories, 2:127  
   discount stores, 3:102  
   Ford, Tom, 2:109–110  
   Fort, Tom, directorship of, 2:255  
   handbags, 2:172  
   hip-hop style, 2:216, 217  
   Italian fashion, 2:254  
   leather, 2:345  
   logo, 2:360, 361  
   Madonna and, 2:372  
   military style, 2:410  
   1990s fashion, 3:353  
 Guerin, Madame, 2:411  
 Guernseys, 2:309  
 Guess? Jeans, 2:274  
 Guibourgé, Philippe, 1:254  
 Guilds  
   ceremonial tapestries, 3:266  
   economics and clothing, 1:401  
   knitting, 2:309  
   shoemakers, 3:164–165  
   tailoring, 3:261–262  
 Guinness, Lulu, 2:173  
 Guise, Henri, Duc de, 2:131  
 Guy, Maria, 2:412  
 Gym uniforms, 2:133  
 Gypsies. *See* Roma and gypsies
- H**  
 Habermacher, René, 2:49  
 Habitat buttons, 1:208  
 Hadiths, 2:403  
 Haida, 1:45  
 Hair accessories, 2:157–160  
 Hair and hairstyles, 2:161–165  
   African American, 1:14–16  
   Afros, 1:25–28  
   ancient Mesopotamia, 1:52  
   ballroom dress, 1:335  
   barbershops, 1:120  
   bobs, 2:157–158  
   China, 1:260  
   close-cropped, 1:25, 27  
   Egypt, ancient, 1:54  
   flower-adornment, 2:159  
   hair replacement, 2:234  
   high-top, 2:430, 431  
   India, 2:237  
   Iran, 2:248  
   Jewish dress, 2:284–285  
   Korean women, 2:314  
   Marcel wave, 2:160  
   Middle Ages, 1:422  
   Minoan, 1:55  
   mohawks, 3:67, 68  
   religious dress codes, 3:98  
   Rome, ancient, 1:58  
   Sub-Saharan Africa, 1:22  
   wigs, 3:429–431  
   women's barbershop patronage, 1:119–120  
 Hair care, 1:15, 16, 25, 27  
 Hairdressers, 2:160–161  
*Hakama*, 2:268–270, 269  
 Halachah, 2:284  
 Hale, Sarah Josepha, 2:148–149  
 Half-tone printing process, 2:62  
 Hall, Jerry, 3:243  
 Hall, Radclyffe, 1:344  
 Halloween costumes, 2:165–167, 166  
 Halston, 2:167–169  
   caftan style, 1:212  
   celebrity, 2:52  
   eyewear, 1:434  
   handbags, 2:172  
   homosexuality, 2:32  
   minimalism, 3:20  
   pajama dressing, 3:14–15  
   perfume, 3:36  
*Hamatsa*, 2:392  
 Hamill, Dorothy, 3:188  
 Hamnett, Katharine, 2:117  
 Hampton, Fred, 1:347  
 Han dynasty, 1:262, 3:293  
*Hanbok*, 1:84, 263  
 Hancock, Thomas, 3:195  
 Hand-knitted sweaters, 3:245  
 Hand knitting, 2:307–308  
 Hand spinning, 3:208–209, 211  
 Handbags and purses, 2:169, 169–174  
   Cashin, Bonnie, 1:232–233  
   Chanel, Gabrielle (Coco), 1:253  
   Fendi, 2:77–78



- Handbags and purses (*continued*)  
 Gucci, 2:155–156  
 Hermès, 2:201–202  
 Leiber, Judith, 2:349  
 Marimekko, 2:385  
 1990s fashion, 3:353  
 Handler, Ruth, 1:121  
 Handweaving, 3:413  
 Handwoven textiles, **2:174–175**  
 folk dress, 2:100  
 saris, 3:138–140  
 Hanes underwear, 3:342  
*Haniwa*, 2:266  
 Hanoverian Fringe Tiara, 1:326  
 Hansen, Karen Tranberg, 3:154  
 Hansen, Patti, 3:243  
 Hard hats, 2:197  
 Hard Upper Torso Assembly (HUT), 3:202  
 Harding, Tim, 3:413  
 Hargreaves, James, 3:210, 212  
 Harlequin framed eyeglasses, 1:433  
 Harlow, Jean, 2:221  
 Harlow, Shalom, 3:244  
*Harper's Bazaar*  
 Avedon, Richard and, 1:104  
 bikinis, 1:156  
 costume jewelry, 1:304  
 Dahl-Wolfe, photography of, 1:333, 334  
 editorial slant, 2:54  
 fashion illustration, 2:49  
 Hoyningen-Huene, George, 2:228  
 patterns, 3:26  
 Vreeland, Diana, 3:406–407  
 Harris tweeds, 3:347, 347  
 Harrods of London, 1:361, 362  
 Hart, Spencer, 3:143  
 Hartnell, Norman, 2:175, **175–177**  
 fashion of, 2:176  
 homosexuality, 2:32  
 London fashion, 2:361  
 Hassidic Jewish dress, 2:287–288  
 Hat Making Museum, 2:185–186  
 Hats, **2:177–181**, **181–186**  
 Chanel, Gabrielle (Coco), 1:249  
 cocktail hats, 1:274  
 cowboy, 1:314, 315  
 feathers, 2:74–75  
 felt, 2:76  
 Halston, 2:168  
 James, Charles, 2:258  
 men's, 2:179, 180, 181  
 milliners, 2:411–415  
 Qing dynasty, 1:264  
 Treacy, Philip, 3:334–335  
 trimmings, 3:338  
 women's, 2:182, 183, 184, 411, 413, 414  
 World War II Germany, 2:11  
*See also* Head wear; Headdresses; Milliners  
 Hatshepsut, 1:320  
 Haute couture, **2:186–189**  
 art and fashion, 1:71–72, 73  
 Chambre Syndicale de la Couture Parisienne, 3:57  
 changes of the 1960s, 3:128  
 collection size, 3:22  
 decline of, 1:403  
 embroidery, 1:408–409  
 fashion designers, studies on, 2:20  
 fashion models, 2:59  
 fashion shows, 2:68, 69  
 French system, 2:186–189  
 garment trade, 2:126  
 Hawes, Elizabeth, fashion criticism of, 2:190  
 knitwear, 2:310  
 Madonna, 2:372  
 New Look, 2:451–452  
 1920s, 3:349  
 1950s, 3:350–351  
 1980s, 3:353  
 origins, 1:402  
 production and manufacturing, 1:72–74  
 Smith, Willi, dislike by, 3:193  
 t-shirts, 3:343  
 tailored suits, 3:260  
 youth style, 2:375  
*See also* Paris fashion; Specific designers  
 Hawaii  
 bark cloth, 1:125–126  
 ceremonial costumes, 1:245  
 hemp, 2:200  
 indigenous people's dress, 1:96–97  
 missionaries and indigenous people, 3:99  
 textiles, 3:307–308  
 Hawaiian shirts, 1:97, **2:189–190**  
 Hawes, Elizabeth, **2:190–191**  
 on the Callot sisters, 1:216  
 Japonisme, 2:272  
 Hawthorne, Steve, 2:235, 421  
 Hay, Harry, 2:136  
 Hayworth, Rita, 3:250  
 Hazmat suits, 3:59  
 Head, Edith, 2:37, 191, **191–192**  
 Fashion Group, 3:57  
 film and fashion, 2:82  
 Hitchcock films, costume design for, 2:84  
 Hollywood style, 2:222  
 New Look inspiration, 2:47  
 Orientalism, 3:6  
*Sabrina* costumes, 2:83  
 Head wear  
 African Americans, 1:14–15, 15  
 Central Asian dress, 1:79  
 China, 1:260  
 court dress, 1:313  
 Egypt, ancient, 1:54  
*'imama*, 2:293–294  
 Iran, 2:249  
 Islamic dress, 2:252  
 Jewish dress, 2:284–286  
*kaffiyeh*, 2:293–294, 294  
 Kyrgyzstan, dress of, 1:82  
 Mesopotamia, 1:52–53  
 Middle Ages, 1:422  
 military, 3:366  
 Minoan, 1:55  
 Ottoman Empire dress, 2:407  
 Russian dress, 3:125  
 Sub-Saharan Africa, 1:22–23, 23  
 Turkmenistan, 1:81  
 wedding costumes, 3:427  
*See also* Hats; Headdresses; Milliners  
 Headbands, 3:279  
 Headbangers, 3:2, 234  
 Headdresses, **2:192–195**, 193, 194  
 African, 1:15, 15–16, 23  
 batik, 1:129  
 eighteenth century, 2:163  
 military, 3:366  
 turbans, 3:343–344  
*See also* Hats; Head wear; Milliners  
 Healing process for brandings, 1:186–187  
 Health and Artistic Dress Union, 3:412  
 Health aspects of dress and fashion, **2:43–46**  
 aesthetic dress, 1:12, 2:220  
 branding, 1:186  
 corsets, 1:290–291  
 cosmetics, 1:295  
 embedded sensors, 3:273  
 felt production, 2:76  
 high heels, 2:204–205  
 implants, 2:235  
 Jaeger, Gustav, 1:381  
 men's underwear, 1:182  
 nudism, 2:458  
 safety skirts, 1:412  
 sandals, 3:136  
 scarification, 3:144–145  
 society dresses v. health dress, 3:348  
 tattoos, 3:270  
 theatrical costumes, 3:324  
 women's shoes, 3:177  
 Healthy and Artistic Dress Union, 1:12, 2:220  
 Hearst, Austine, 2:258  
 Hearth rugs, 3:289  
 Heat  
 acetate, reaction of, 3:83  
 glazing, 2:143  
 Heat shrinking, 3:32  
 Heavy Metal, 3:234  
 Hebdige, Dick, 3:68, 233, 234  
 Heddles, 3:306  
 Hedges, Sharon, 3:413  
 Hedstrom, Ana Lisa, 3:328, 414  
 Heian period, 2:267, 300  
*Heideloff's Gallery of Fashion*, 2:66  
 Heim, Jacques, 1:352, 3:6  
 Heimann, Betsy, 2:85  
 Held, John, Jr., 2:89

- Helena of Schallenberg, 3:119  
 Hellenistic chitons, 1:57  
 Hell's Angels, 3:233, 234  
 Helmets, **2:195–198**, 196  
   bicycle, 1:155  
   military, 3:366, 368  
 Helvin, Marie, 2:59  
 Hemlines, **2:198–200**  
   Chanel, Gabrielle (Coco), 1:250  
   movies and, 2:85  
   1980s fashion, 3:352  
   skirts, 3:190  
 Hemp, **2:200–201**  
 Henna, 1:21–22, 294, 3:270  
 Henry VIII  
   codpiece, 1:276  
   headwear, 2:178  
   overgowns, 3:8  
   sneakers, origins of, 3:194  
 Hepburn, Audrey, 3:460  
   in black dress, 2:359  
   film and fashion, 2:82, 83  
   Givenchy, Hubert de and, 2:141  
   tiaras, 1:326  
 Hepburn, Katharine, 3:220, 388  
 Hepworths, 1:50–51  
 Heraldry, 1:69, 3:229  
 Herbault, Madame, 2:411  
 Hermès, **2:201–202**  
   handbags, 2:173  
   Lacroix, Christian, 2:327  
   leather, 2:345  
   Marni, Martin, 2:382  
   scarves, 3:143  
   suede, 2:345  
   travel accessories, 2:171  
 Heroin chic, **2:202–204**  
 Herrera, Carolina, 2:335, 3:203  
 Herringbone twills, 3:420  
 Hessian boots, 1:174  
 High heels, **2:204–205**, 205  
   cross-dressing, 1:322  
   European fashion, 3:169  
   Ferragamo, Salvatore, 2:79  
   footbinding and, 2:107, 107  
   health aspects, 2:44  
   seventeenth century, 3:174  
   stiletto, 3:177  
 High schools, 1:2  
*High Society: The Real Voices of Club Culture* (Harrison), 1:336  
 High-tech fashion, **2:205–209**, 206, 207  
   fibers, 2:82  
   future, 2:117  
   health aspects, 2:45–46  
   *See also* Techno-textiles  
 High topper hats, 2:179  
 Highland dress, 2:301–302, 3:148–149, 267–268, 437  
 Highlights, color, 1:282  
*Hijab*, 1:246–247, 370, **2:209–213**, 211  
*Hijra*, 1:320  
 Hiler, Hilaire, 2:18  
 Hilfiger, Tommy, **2:213–214**  
   celebrities, use of, 1:240  
   Courrèges, André, influence of, 1:311  
   designer jeans, 2:275  
   fashion television, 2:71  
   hip-hop style, 2:217  
   logo, 2:361  
   sport shirts, 3:213  
 Hill, Thomas E., 1:204  
 Hindu dress and fashion  
   Bangladesh, 1:92  
   cosmetics, 1:294  
   cross-dressing, 1:320, 320  
   overview, 3:97  
   Sri Lanka, 1:90  
 Hinged bracelets, 1:183, 184  
 Hip-hop, **2:214–218**, 216  
   boxer shorts, 1:182  
   dance and fashion, 1:336  
   Hilfiger, Tommy, 2:213–214  
   jeans, 2:275  
   men's hats, 2:178  
   music and fashion, 2:432  
   sweatshirts, 3:246  
   teenage fashion, 3:276  
   Vuitton, Louis, 3:408  
 Hippie style, **2:218–219**  
   dashikis, 1:346  
   ethnic style, 3:6  
   folklore look, 2:103  
   music and fashion, 2:433  
   1960s fashion, 3:351  
   psychedelic fashion, 3:62–63  
   sandals, 3:136  
   teenage fashion, 3:276  
   tie-dyeing, 3:327–328  
   vintage fashion, 3:399  
   waistcoats, 3:410  
   Youthquake fashion, 3:461–462  
 Hiro, 2:64  
 Hirschfeld, Magnus, 1:322–323  
 Hirst, Frederic, 2:185  
 Hisdal, Solveig, 2:310  
 Hishinuma, Yoshiki, 2:420  
 Hispanic Americans. *See* Latino style  
 Historians  
   Laver, James, 2:341–343  
   Moore, Doris Langley, 2:421–422  
 Historic laces, 2:326  
 Historic revivals. *See* Revivals, historic  
 Historical studies of fashion, **2:16–21**  
   Chinese textiles, 3:295–296  
   traditional dress, 3:331–332  
   Uzanne, Octave, 3:384–385  
   *See also* Theory of fashion  
 Historicism, **2:219–221**  
   Galliano, John, 2:125–126  
   theatrical costumes, 3:323  
   women's shoes, 3:176  
   Worth, Charles Frederick, 3:448  
 History of dress  
   ancient world, 1:51–58, 51–59  
   art *vs.* fashion's depiction of, 1:72  
   Australia, 1:101–102  
   Barthes, Roland, 1:128  
   Baudrillard, Jean, 1:132–134  
   Benjamin, Walter, 1:147–148  
   Central America and Mexico, 1:37–41  
   Central Asia, 1:78–82  
   China, 1:260–266  
   Cunnington, C. Willett and Phillis, 1:328–329  
   diplomatic uniforms, 3:362  
   East Asia, 1:82–85  
   Eastern European folk dress, 2:93–97  
   Europe and America, 1:418–427  
   gender and dress, 2:131–132  
   Indian fashion industry, 2:239–240  
   Iran, 2:248–249  
   Laver, James, 2:341–343  
   leather and sued, 2:343–344  
   men's shoes, 3:171–172  
   Middle Eastern Islamic dress, 2:402–409  
   Moore, Doris Langley, 2:421–422  
   North Africa, 1:16–19  
   North American indigenous peoples, 1:42–45  
   overview, 2:25–26  
   Russia, 3:121–127  
   secondhand clothes, 3:153–155  
   shirts, 3:162  
   South America, 1:45–49  
   South Asia, 1:85–93  
   Southeast Asian and Pacific Islands, 1:93–97  
   Southeast Asian Mainland, 1:97–101  
   Sub-Saharan Africa, 1:19–24  
   wedding costumes, 3:425–426  
 Hitchcock, Alfred, 2:191  
 HIV/AIDS  
   Ellis, Perry, 1:407  
   Halston, 2:168  
   red ribbons, 3:108  
 Hmong  
   gender and dress, 2:131  
   necklaces, 2:443  
   ornamentation of garments, 1:99  
   story quilts, 3:317  
   wedding headdresses, 2:194–195  
 Hobble skirts, 3:348  
 Hogarth, William, 1:226, 227  
 Hogg, Pam, 3:149  
 Holland. *See* The Netherlands  
 Holland, William, 1:226  
 Hollar, Vaclav, 2:66  
 Hollywood Boot Shop, 2:78–79  
 Hollywood patterns, 3:26  
 Hollywood style, **2:221–222**  
   sunglasses, 3:240  
   swimwear, 3:250, 253  
   window displays, 3:435  
   *See also* Actors and actresses; Film and fashion  
*Holulu*, 1:97

- Home furnishings. *See* Interior design and decoration
- Home-shopping retailers, 3:102
- Homemade clothing  
folklore look, 2:102  
sewing machines, 3:158
- Homespun, **2:222–224**, 223, 3:309, 347
- Homosexuality and fashion, **2:29–34**, 30, 33  
cross-dressing, 1:322  
Gernreich, Rudi, 2:136  
Halloween costumes, 2:167  
kilts, 2:302  
Wilde, Oscar, 3:432
- Hong Kong  
*qipao*, 3:71  
school uniforms, 3:376
- Honorific gifts  
Muhammad, 2:404  
Ottoman Empire, 2:406  
robes of honor, 3:113
- Hood, Thomas, 3:150, 151
- Hoods  
men's, 2:177–178  
prison dress, 3:55
- Hook-and-loop closures, **1:270**, 2:72
- Hookless Fastener Company, 3:465
- Hooks and eyes, 3:465
- Hoop earrings, *1:394*
- Hooped dresses, 3:448
- Hoopla dress, 1:268
- Hoopskirts, 1:317–318, 427, 3:191
- Hope, Thomas, 2:17, 220
- Hopi Kachina costumes, *1:43*
- Hopi masks, 2:391
- Horizontal ground-loom, 2:364
- Horn rims, 1:433, 434
- Hornby, Lesley. *See* Twiggy
- Horror fiction, 2:151
- Horse riding costumes. *See* Equestrian costumes
- Horst, Horst P., **2:224–226**, 225  
Madonna, influence on style of, 2:371  
Steichen, Edward, influence of, 2:63
- Horta, Victor, 1:362
- Horyn, Cathy, 2:54
- Hosiery, **2:226–227**  
breeches and, 1:193  
doublets and, 1:374–375  
hosiers, 3:263  
*See also* Stockings
- Hot pants, 3:352
- Hot pink, 2:315, 3:146
- Houndstooth twills, 3:420
- Houppelandes*, 1:422
- House of Fraser, 1:362
- House of Style* (television show), 2:71
- Housewives  
aprons, 1:65–66  
Fogarty, Anne, designs of, 2:92
- Howe, Elias, 3:86, 157, 195
- Howe, John, 3:38
- Howell, Georgina, 1:33
- Hoxton style, 1:345
- Hoyningen-Huene, George, 1:104, **2:227–229**  
Horst, Horst P. and, 2:224, 226  
Steichen, Edward, influence of, 2:62–63
- Hue, 1:280–281
- Hughes, Talbot, 2:18, 19
- Hugo Boss, **2:229–230**
- Hulanicki, Barbara  
art nouveau, 1:77  
Biba, 1:153–154  
Youthquake fashion, 3:459–462
- Humane trapping, 2:116
- Humanism, 2:181–182
- Humor in fashion  
Mackie, Bob, 2:369–370  
Moschino, Franco, 2:423–424
- Humors, 2:43
- Humphrey, William, 1:226
- Hungary  
folk dress, 2:95  
military uniforms, 3:366
- Hunt, Walter, 3:129
- Hunting  
camouflage cloth, 1:218  
coats, 3:217  
equestrian clothing, 1:413
- Hurley, Elizabeth, 1:238
- Hurluberlu, 2:163
- Huryñ, Nina Vivian, 3:413
- Hussars, 3:366
- HUT (Hard Upper Torso Assembly), 3:202
- Hutterites, 3:99
- Hutton, Lauren, 2:401
- Hygiene  
barbers, 1:119, *120*  
body piercing, 1:169  
laundry, 2:339
- I**
- Ianina, Iulia, 3:127
- ICFTU (International Confederation of Free Trade Unions), 2:321–322
- Iconography  
Byzantine textiles, 3:287–288  
Central American and Mexican dress, 1:40  
jewelry, 2:279–281  
rings, 3:109
- ID* (magazine), 2:56
- Identification  
bracelets, 1:183  
military uniforms, 3:364
- Identity, **2:34–35**  
Afrocentric fashion and, 1:28, 30  
Andean dress, 3:285  
Australian dress, 1:102  
ceremonial costumes, 1:243
- Chalayan, Hussein, 1:248  
consumption, 3:178  
ecclesiastical dress and, 1:399–400  
gay signifiers, 2:31–32  
goths, 2:151–152  
hip-hop, 2:214–215  
kente, 2:300  
penis sheaths, 3:29–30  
religion and dress, 3:96–100  
school uniforms, 3:377  
Southeast Asian textiles, 3:315  
street style, 3:226–228  
theory of fashion, 2:23–24  
veiling, 2:212–213
- Ideology  
Modern Primitives, 2:421  
religion and dress, 3:97–98
- Ifugao, 3:152–153
- Ikat, **2:231–233**, 3:290, 301
- Illustrators. *See* Fashion illustrators
- ILO (International Labour Organization), 2:321
- Imama*, 2:293–294
- Iman, 2:65, 401, 3:243
- Imitation, 3:186, 336
- Immigrants  
garment workers, 1:403, 2:51, 144–145, 3:86  
laundry work, 2:339  
tailors, 3:85
- Imperfection, 3:454–455
- Implants, **2:233–235**
- Imports. *See* Trade
- Imprinted t-shirts, 3:342–343
- Inca dress, 1:47, 3:284
- Incorporated Society of London Fashion Designers  
Hartnell, Norman, 2:176  
haute couture, 2:188
- India  
calico, 1:213, 214, 217  
cashmere and pashmina, 1:233–235  
chintz, 1:267  
colonialism and composite dress, 1:279  
cosmetics, 1:293–294  
cotton production, *1:307*, 308  
department store mannequin, 2:378  
ethnic dress, 1:415  
European influence, 1:87–88  
fashion education, 2:42  
history of dress, 1:88  
homespun, 2:224  
ikat, 2:232–233  
indigo production, 2:241–242  
jewelry, 2:281  
muslin, 2:434, 435  
Nehru jackets, 2:449–450  
Orientalism, 3:5  
*salwar-kameez*, 3:133–134  
saris, 3:138–140  
secondhand clothes, 3:153  
shawls, 3:160–161  
textiles, 3:309–310, 318



- turbans, 3:344  
veils, 3:392
- India rubber cloth, 3:79, 80
- Indian dress, **2:235–241**, 236, 237, 238, 239
- Indigenous peoples  
Australia, 1:101–102  
colonialism and dress, 1:277–280  
Latin America, 2:333  
missionaries and dress, 3:99  
North American, 1:42–45  
Pacific Islands, 1:95–97  
South American dress, 1:45–49
- Indigo, **2:241–242**  
*adire*, 1:9, 10  
calico, 1:213  
history of use, 1:389  
tie-dyeing, 3:327  
West African textiles, 3:281
- Indonesia  
bark cloth, 3:313  
batik, 1:129–130  
Dutch influence, 1:415–416  
ethnic dress, 1:415  
Islamic dress, 1:94, 2:253  
*kain-kebaya*, 2:294–295  
sarongs, 3:141–142
- Industrial laundries, 2:339–340
- Industrialization  
Brooks Brothers, 1:197  
calico production, 1:215  
Europe and American fashion, 1:425  
jewelry, 2:282  
mechanization of production, 1:402  
men's hats, 2:179–180  
millinery industry, 2:183–184  
ready-to-wear, 3:86–89  
social class and fashion, 1:133  
spinning, 3:210–211  
textile trade, 3:318–319  
women's tailored suits, 3:259
- Infants  
clothing, 2:260  
layettes, 1:257, 259  
swaddling, 1:256, 256, 3:169–170
- Infineon Technologies, AG, 3:273
- Infrastructure, fashion industry, 2:50
- Initiation ceremonies. *See* Rites of passage
- Ink rubbing, 3:144
- Inlay appliqué, 1:64
- Innovation  
London fashion and retailing, 2:362  
philosophy of fashion, 3:186  
theories of, 2:22
- Inside Subculture* (Muggleton), 3:236
- Institut de France, 3:372
- Insulation  
felt, 2:75  
wool, 3:443
- Intellectuals  
Barthes, Roland, 1:127–128  
Baudrillard, Jean, 1:132–134
- Intelligent fashions, 2:209, 3:272–274
- Intensity, color, 1:281
- Interior design and decoration  
handwoven textiles, 2:174  
Kawakubo, Rei, 1:285  
Lanvin, Jeanne, 2:332  
Liberty & Co. furnishings, 2:354  
Martine style, 3:46  
polyester home furnishings, 3:54  
“International Best-Dressed Poll,” 1:152
- International Confederation of Free Trade Unions (ICFTU), 2:321–322
- International Contest of Hat Designers, 2:185–186
- International Exhibition (1862), 1:12
- International labor organizations, 2:321–322
- International Labour Organization (ILO), 2:321
- International Ladies Garment Workers Union (ILGWU), 1:164, 2:51
- International textile trade, **3:318–320**, 321
- Internet  
clothing sales, 1:404  
e-tailers, 3:102–103  
fashion editors' use of, 2:41  
fashion journalism, 2:54  
fashion marketing, 2:208  
fashion online, 2:61–62  
globalization of garment trade, 2:127  
Lang, Helmut, marketing of, 2:329
- Intersexed persons, 2:129
- Inuit and arctic dress, **2:242–246**, 243, 244, 245  
footwear, 2:246–248  
fur, 2:116  
history, 1:44  
*kamiks*, 1:173  
masks, 2:389, 389–390  
parkas, 3:21, 433
- Inuit and arctic footwear, **2:246–248**, 246, 247
- Invented tradition, 2:313
- Inventions  
acetate, 3:82  
bicycles, 1:154  
brassieres, 1:190  
cotton gin, 1:306, 308, 3:211  
electric tattooing implements, 3:270  
halftone printing process, 2:62  
hook-and-loop closures, 1:270  
Jacquard looms, 3:415, 424  
jock straps, 1:154  
Kevlar, 3:59  
knitting frame, 2:308–309  
knitting machine, 2:311  
lasting machines, 3:195  
leather-splitting machine, 2:344  
leather tanning method, 2:344  
lipstick in a sliding tube, 2:358  
little kilt, 2:301  
looms, 3:424
- Nomex, 3:59  
nylon, 2:461  
oilskins, 3:2  
pins, 3:38  
pleating device, 2:113  
polyester, 3:52  
raincoats, 3:9  
safety pins, 3:129  
safety razors, 1:119, 136  
sewing machines, 3:157, 195  
shoemaking tools, 3:167  
silicone breast implants, 2:234  
spinning machinery, 3:210–212  
sports bra, 3:361–362  
tape measure, 1:331  
vinyl, 3:400  
vulcanization of rubber, 3:120  
zippers, 3:465  
*See also* Patents
- Ionic chitons, 1:56, 57
- Iranian dress, **2:248–250**  
chador, 1:246–247  
Islamic dress, 2:408–409  
*jilbab*, 2:289  
Medes and Persians, 2:403
- Ireland  
crochet, 1:318–319  
folk dress, 2:98  
linen, 2:355
- Iribe, Paul, **2:250**  
fashion plates, 2:67  
Poiret, Paul, illustrations for, 2:49  
Poiret, Paul and, 3:45
- Ironside, Janey, 3:459
- Iroquois masks, 2:390
- Irwin, Elaine, 3:243
- Isabey, Jean Baptiste, 1:312–313, 324
- Ishimoto, Rujiwo, 2:384
- Islamic dress, **2:250–254**, **402–409**  
adinkra, 1:7  
Balkan folk dress, 2:96  
Bangladesh, 1:92  
boubous, 1:176  
burqas, 1:89, 202–203  
chador, 1:246–247  
cross-dressing, 1:320  
*djellaba*, 1:369–370  
dress code, 3:97  
ethnic dress, 1:416  
gender, 2:133  
*hijab*, 1:370, 2:209–213  
India, 1:88  
Indonesia, influence on, 2:294–295  
*jilbab*, 2:288–290  
*kaffiyeh*, 2:293–294  
Maldives, 3:310  
men at prayer, 3:96  
robes of honor, 3:113  
South Asian dress, influence on, 1:87  
Sri Lanka, 1:89  
Sub-Saharan African headwear, 1:23  
turbans, 3:344  
veils, 3:392–394

- Islamic dress (*continued*)  
 See also Arab dress; Middle Eastern dress
- Islamic Orientalism, 1:338
- Islamic textiles. *See* Middle Eastern textiles
- Isogawa, Akira, 1:103
- Isola, Maija and Kristina, 2:383
- It Happened One Night* (film), 2:84, 3:13, 14
- Italian fashion, **2:254–256**  
 business suits, 3:238  
 futurist fashion, 2:118–119  
 See also Specific designers
- The Italian Job* (film), 2:84
- Italian Look, 2:254–255
- Italy  
 commedia dell'arte, 3:322  
 fashion education, 2:42  
 Galleria del Costume, 2:60  
 Renaissance style, 1:422–423  
 shoemaking, 3:167
- Iudashkin, Valentin, 3:127
- Iusupov, Prince, 3:125
- Ivan IV, 3:123
- Ives, Frederic Eugene, 2:62
- Ivory Coast  
 cosmetics, 1:294  
 rites of passage costumes, 1:242
- Ivy League style  
 Brooks Brothers, 1:198–199  
 chino, 3:420  
 Japanese men, 2:262  
 1920s, 3:275  
 suits, 3:237  
 See also Preppy style
- J**
- Jack-type looms, 2:362–364
- Jackets, **2:257**  
 blazers, 1:160–161, 3:219, 219, 376  
 dinner jackets, 3:131, 345  
 Nehru, 1:224  
 nineteenth century, 3:9  
 sports jackets, 3:216–217  
 twentieth century, 3:10  
 Windsor, Duke of, 3:436
- Jackson, Jesse, 1:347
- Jackson, Linda, 1:102
- Jackson, Michael, 1:336
- Jacob, Mary Phelps, 3:361
- Jacobs, Marc  
 Clark, Ossie, influence of, 1:269  
 Courrèges, André, influence of, 1:311  
 Ellis, Perry and, 1:407  
 fashion illustrators, collaboration with, 2:49  
 grunge, 2:154  
 handbags, 2:173  
 logos, 2:360  
 perfume, 3:36
- Vuitton, Louis, 3:408
- Jacquard weave, 3:107, 161, **3:415**, 424
- Jaeger, Gustav, 1:376, 381, 3:341
- Jagessar, Lionell, 1:231
- Jamaican rude boys, 3:235
- James, Cassie Myers, 2:86
- James, Charles, **2:257–260**, 258  
 Clark, Ossie, influence on, 1:268  
 ribbons, 3:107  
 Steele, Lawrence, influence on, 3:222
- James, Michael, 3:75
- James, Richard, 3:143
- Jantzen swimwear, 3:252–253
- Japanese dress and fashion, **2:260–265**, 262, 264, **265–271**  
 colonialism, 1:278–279  
 Comme des Garçon, 1:283–285  
 diplomatic uniforms, 3:363  
 dress codes, 1:377–378  
 ethnic dress, 1:415  
 ethnic style, 1:417  
 extreme fashion, 1:432  
 fans, 2:5  
 hair sticks, 2:159  
 headdresses, 2:194  
 history, 1:84–85  
 Japanese designers, 2:262*t*, 264*f*  
 kimonos, 2:302–303  
 masks, 2:388–389, 390  
 1980s, 3:352  
 occupational uniforms, 3:372  
 school uniforms, 3:374–377  
 secondhand clothes, 3:155  
 unisex clothing, 3:384  
 wearable PC, 2:207  
 wedding headdresses, 2:195  
 Western fashion, 1:280, 2:304–305  
 yukata, 3:462, 462–463  
 See also Specific designers
- Japanese textiles, 2:208, **3:299–302**, 327
- Japonisme, 2:261, 265, **271–272**, 3:412  
 See also Orientalism
- Jasperware buttons, 1:208
- Java  
 batik, 1:129–130  
*kain-kebaya*, 2:294–295  
*lurik*, 3:314  
 sarongs, 3:141
- Javits, Eric, 2:414
- Jazz style, 3:466–468
- Jeans, **2:272–276**  
 Calvin Klein advertisement, 2:28–29, 275  
 denim, 1:360  
 distressing, 1:368–369  
 innovation, 2:22  
 Levi Strauss, 2:351–353  
 Soviet Union, 1:288  
 teenage fashion, 3:276
- Jennings, Dare, 1:103
- Jersey, **2:276–277**  
 A-POC, 2:420  
 Chanel, Gabrielle (Coco), 1:249, 253
- Jerseys. *See* Sports uniforms
- Jesse, William, 1:343
- Jet looms, 3:424
- Jet pack fashion, 3:468
- Jewelry, **2:277–283**  
 African American dress, 1:14  
 aromatic, 3:35  
 beads, 1:134–135  
 bracelets, 1:182–184  
 brooches and pins, 1:195–197  
 Chanel, Gabrielle (Coco), 1:251, 252  
 costume jewelry, 1:302–306  
 cuff links and studs, 1:327–328  
 earrings, 1:391–395  
 Egypt, ancient, 1:54  
 formal wear, men's, 2:111  
 India, 2:236–237  
 knotting, 2:312  
 Kyrgyzstan, dress of, 1:82  
 Masai, 2:194  
 necklaces and pendants, 2:441–444  
 North American indigenous peoples, 1:43  
 occult dress, 3:1–2  
 Peruvian, 1:47, 48  
 Rabanne, Paco, 3:77  
 rings, 3:108–110  
 Sub-Saharan African dress, 1:22  
 Windsor, Duchess of, 3:438–439
- Jewish dress, **2:284–288**, 3:95  
 dress code, 3:97  
 Hasidic Jews, 3:98  
 Purim, 2:167  
 social control, 3:99  
 veils, 3:393  
 wedding headdresses, 2:195
- Jilbab*, 1:369–370, 2:210, 252, **288–290**
- Jin dynasty, 3:294–295
- Jock straps, 1:154
- Jockey shorts, **2:290–291**
- Jockeys' clothing, 1:413, 3:379
- Jodhpurs, 1:413
- Johanna Theresia, countess of Harrach, 3:118
- John, Mr., 2:413
- John-Frederic, 2:184–185
- John Paul I, Pope, 1:399
- Johns, Jasper, 3:435
- Johnson, Betsey, 2:350
- Johnson, Jeff, 3:215
- Jolly Belin Dye Works, 1:384
- Jones, Bobby, 2:149
- Jones, Grace, 2:430, 430
- Jones, Stephen, 2:414
- Jorgensen, Christine, 1:323
- Joseph, 3:245
- Joseph II, King of Germany, 3:116–117
- Jourdan, Charles, 1:32, 177–178
- Journal der Luxus und der Moden*, 2:55
- le Journal des dames et des modes*, 1:124
- Journalism and celebrities, 1:239
- Jousts, 1:70
- Joy (perfume), 3:24, 36

- The Judgement of Paris* (Barbier), 1:124  
Judges. *See* Legal and judicial costume  
Judicial costume. *See* Legal and judicial costume
- Judson, Whitcomb, 3:465  
Jumper dresses, **2:291**  
Jupe-culottes, 3:46  
*Jupes culottes*, 3:348  
Justema, Willam, 1:398
- K**
- Kabuki, 2:270, 304, 3:325  
Kachinas, 1:43, 2:391  
*Kaffiyeh*, 2:252, **2:293–294**, 294  
*Kain-kebaya*, **2:294–295**  
*Kain panjang*, 3:141  
*Kajal eyeliner*, 2:238  
Kalabari  
  gender and dress, 2:130, 131  
  masks, 2:389  
  rites of passage costumes, 1:242  
Kamakura period, 2:267, 3:300  
Kamali, Norma, **2:295–296**, 296  
  sweatshirts, 3:246  
  swimwear, 3:255  
*Kamiks*, 1:173  
*Kampala*, 3:281  
Kanbun style, 2:304  
Kandinsky, Vasily, 1:172  
Kane, Art, 2:64  
Kanga, 1:346–347, **2:297–298**  
Kani, Karl, 2:216  
*Kantba*, 3:308  
*Kanzashi*, 2:157  
Kaplan, Melissa, 2:432  
Karan, Donna, **2:298–299**  
  boutiques, 3:102  
  celebrities, use of, 1:240  
  Clinton, Hillary Rodham, turtleneck dress worn by, 2:86  
  costume design, 2:83  
  Courrèges, André, influence of, 1:311  
  designer jeans, 2:275  
  on Halston, 2:168  
  leather, 2:345  
  1980s fashion, 3:352  
  perfume, 3:36  
  sweaters, 3:245  
  t-shirts, 3:343  
  vintage fashion, 3:400  
Karsavina, Tamara, 1:115  
*Kasaya*, 3:311  
Kashmir shawls, 1:234–235, 3:12, 161  
Katsuji Wakisaka, 2:384–385  
Katz, Karen, 1:158  
Kauffer, Edward McKnight, 3:435  
Kawakubo, Rei  
  camouflage cloth, 1:219  
  Comme des Garçons, 1:283–285  
  ethnic style, 1:417  
  extreme fashion, 1:432  
  Japanese fashion, 2:263, 265  
  Japonisme, 2:272  
  little black dress, 2:360  
  Miyaki, Issey and, 2:417–418  
  1980s fashion, 3:352  
  Paris fashion, 3:20  
  technology and fashion, 2:208  
  unisex clothing, 3:384  
  Yamamoto, Yohji and, 3:453, 454  
Kay, John, 3:210, 424  
Kayapo Indians, 1:294  
Keaton, Diane, 2:85  
Keds, 3:170–171, 195  
Kee, Jenny, 1:102  
Keefe, Tammis, 3:143  
Kellerman, Annette, 3:252  
Kelly, Gene, 1:340  
Kelly, Grace, 2:84, 201  
Kelly bag, 2:172, 201  
Kennedy, Jacqueline, 2:47  
  American look, 2:86  
  Chanel, Gabrielle (Coco), fashions of, 1:253  
  Fairchild, John and, 3:440  
  as fashion icon, 2:47, 48  
  Givenchy, Hubert de and, 2:141  
  Marimekko dresses, 2:383  
  pillbox hat, 2:183  
  sunglasses, 3:241  
  symbolism of dress, 1:246  
  tailored suits, 3:261  
  Valentino, fashions of, 3:389  
Kennedy, John F., 1:199, 3:241  
Kente, 1:20, 245, **2:299–300**, 3:280  
Kenya, 3:87  
Kenzo  
  ethnic style, 1:417  
  folklore look, 3:352  
  Japanese fashion, 2:263, 265  
  stage *vs.* runway shows, 2:70  
  sweaters, 3:245  
  Western awareness of, 1:283  
Keogh, Lainey, 1:319  
Keowing, Frank, 3:26  
*Kepala*, 3:141  
Kerchiefs, 2:193  
*Kesa*, 2:266, 267, 270  
*Kesi* tapestries, 3:294, 294  
Kevlar, 1:71, 3:59  
*Khadi*, 2:224  
Khaki, 2:410, 3:368  
*Kbalats*, 1:78–79  
Khan, Emmanuelle, 3:128  
*Khimar*, 1:370, 2:210  
Kidman, Martin, 2:310  
Kidman, Nicole, 3:399  
Kieselstein-Cord, Barry, 1:407  
Kiesler, Frederick, 3:434–435  
Kilt pins, 1:195  
Kilts, **2:300–302**, 3:148, 148  
Kimonos, 1:83, **2:302–305**  
  ethnic dress, 1:415  
  history, 1:84, 2:262, 265, 270  
  sleeves, 1:216, 3:402  
  textiles, 3:300  
  Western fashion, influence on, 2:271  
  *See also* Yukata  
King, Muriel, 1:274  
Kinski, Nastassja, 2:64, 65  
*Kira*, 3:311  
Kitmir, 2:102  
KL, 2:328  
Klein, Anne  
  Karan, Donna and, 2:298  
  recognition of, 2:36  
Klein, Calvin, **2:305–307**, 307  
  advertising, 1:239, 2:28–29, 401–402  
  boutiques, 3:102  
  celebrity, 2:52  
  costume design, 2:83, 84  
  designer jeans, 2:274, 275  
  discount stores, 3:102  
  embroidery of Lesage, 2:350  
  eyewear, 1:434  
  grunge, 2:154  
  homosexuality, 2:32  
  leather, 2:345  
  licensing, 2:126  
  masculinized fashions for women, 2:133  
  men's underwear, 1:239, 2:290, 3:353, 361  
  1980s fashion, 3:352  
  perfume, 3:36  
  polyester, 3:53  
  realist aesthetic, 2:203  
  supermodels, 3:243  
  sweatshirts, 3:246  
  t-shirts, 3:343  
  *Women's Wear Daily*, 3:440  
Klein, William, 2:64  
Klensch, Elsa, 2:40–41, 53, 70, 3:440  
Klimt, Gustav, 3:412–413  
Kloss, John, 1:268  
Klum, Heidi, 2:356, 3:244  
Knapp, Sonia, 3:200  
Knickerbockers, 1:194–195, 258, 2:149, 3:218  
Knight, Nick, 2:61, 400  
Knight, Phil, 3:196–197, 215  
Knights  
  armor, 1:69–70  
  ceremonial costumes, 1:244  
Knitting, **2:307–311**  
  domestic production, 1:373–374  
  Spain, 3:205  
  sweaters, 3:245  
  whole garment, 2:37  
  wool, 3:442  
Knitting machinery, **2:311**  
Knitwear  
  hosiery, 2:227  
  linen, 2:356  
  Rykiel, Sonia, 3:128  
  Scottish, 3:149  
  sweaters, 3:244–245  
  sweatshirts, 3:245–247



- Knossos scarf, 2:113  
 Knotting, **2:311–313**, 312, 313  
 Koda, Harold, 2:19, 60–61  
 Kodachrome, 1:333, 2:64  
 Kokosalaki, Sophia, 3:105  
 Kolokol'tsov, D. A., 3:125  
 Komo masks, 2:390  
 Komodo, 3:399  
 Konheim, Bud, 3:156, 157  
 Kool Herc, DJ, 2:215  
 Korean dress and adornment,  
   **2:313–318**, 314, 315, 316  
   Chinese fashion, influence of, 1:263  
   cultural aspects, 2:24  
   ethnic dress, 1:415  
   history, 1:84  
   invented tradition, 2:313  
   Japanese colonialism, 1:278–279  
 Kors, Michael, 3:36, 246  
 Kosciuszko Foundation, 1:349  
 Koshino, Michiko, 2:208  
*Kosode* costumes, 2:268, 270, 303–304  
 Kouyaté, Lamine, 3:451–452  
 Kracauer, Siegfried, 2:387  
 Kraftwerk, 2:430–431  
 Krizia, 1:33–34, 2:255, 3:245  
 Kroenke, Anja, 2:49  
 Krutikova, Irinia, 3:126–127  
 Kuba masks, 2:392–393  
 Kumar, Ritu, 2:240  
 Kushner, Robert, 1:319  
 Kutner, Christophe, 2:65  
 Kuwait, 3:435  
*Kyôgen* costumes, 2:268  
 Kyoto Costume Institute, 2:61  
 Kyrgyzstan, dress of, 1:81–82
- L**
- LAA (Leather Apparel Association),  
 2:345  
 Labanda, Jordi, 2:49  
 Labeling laws, **2:319–321**  
 Labels. *See* Brands and labels  
 Labor issues  
   immigrant garment workers,  
     2:144–145  
   Marx, Karl, 2:386–387  
   seamstresses, 3:150  
   strike at House of Chanel, 1:252  
   textile workers, 3:320–321  
 Labor unions, **2:321–323**  
   International Ladies Garment Workers  
     Union, 1:164  
   sweatshops, 3:248  
   Union of Needletrades, Industrial and  
     Textile Employees (UNITE), 2:51  
 Lace, 2:309, 323, **3:23–327**, 324, 3:338  
*Lacha*, 1:88  
 Lacroix, Christian, 1:326  
 Lacloche, Maison, 1:326  
 Lacoste, René  
   logos, 2:360  
   polo shirts, 3:52  
   sport shirts, 3:213  
   t-shirts, 3:343  
   tennis costumes, 3:278  
 Lacroix, Christian, **2:327–328**  
   caricature, 1:229  
   Clark, Ossie, influence of, 1:269  
   corsets, 1:292  
   costume jewelry, 1:305  
   embroidery of Lesage, 2:351  
   ethnic style, 1:417  
   evening dress, 1:429  
   fashion of, 2:327  
   folklore look, 2:103  
   handbags, 2:173  
   haute couture, 2:188, 189  
   1980s fashion, 3:353  
   pouf skirts, 3:20  
   Pucci collection, 3:66  
   retro style, 3:103  
   tailored suits, 3:261  
 Lacroix, House of, 1:363  
 Lacroix, Paul, 2:17  
 Ladakh, 1:88  
*The Ladies' Book of Etiquette, and Manual  
 of Politeness* (Hartley), 1:335  
*Ladies on Horseback* (O'Donoghue), 1:412  
 Lady Dior handbag, 2:173  
 Lady Jane boutique, 1:180  
*Lady's Magazine*, 2:55  
 Laferrrière, 1:76  
 Lafitte, Mme, 2:38  
 Lagerfeld, Karl, **1:250**, **2:328–329**  
   art and fashion, 1:72  
   caricature, 1:229  
   Chanel, House of, 1:254, 3:20  
   costume jewelry, 1:305  
   embroidery of Lesage, 2:351  
   Fendi, 2:77, 78  
   handbags, 2:173  
   haute couture, 2:188  
   1980s fashion, 3:352  
   perfume, 3:36  
   punk, 3:429  
   ribbons, 3:107  
   supermodels, 3:243  
 L'Air du Temps (perfume), 3:36  
 Laliq, René  
   artists' jewelry, 2:283  
   bracelet, 2:279  
   tiaras, 1:326  
 Lamanova, Nadezhda, 1:286, 287, 3:126  
 Lamarr, Hedy, 3:141–142  
 Lambert, Eleanor, 1:152, 2:52, 53, 3:58  
 Lamour, Dorothy, 2:222, 3:141–142,  
   253  
 Lancaster, Osbert, 1:229  
 Lancel bags, 2:171  
 Landshoff, Herman, 2:64  
 Lane, Jenai, 2:439  
 Lane, Kenneth Jay, 1:304  
 Lang, Helmut, **2:329–330**  
   Alaïa, Azzedine, tribute to, 1:33  
   Internet marketing, 2:208  
   1990s fashion, 3:353  
   rubber wear, 3:121  
   t-shirts, 3:343  
 Lange, Liz, 2:395  
 Langley, Batty, 2:219  
 Langley Moore, Doris, 2:19, 60  
 Langsdorf, Jesse, 2:447  
 Langtry, Lillie, 2:46, 278  
 Lanolin, 3:442  
 Lanvin, Jeanne, **2:330–333**, 331  
   art and fashion, 1:73  
   art deco, 1:77  
   Chanel, as competitor to, 3:19  
   embroidery, 1:408, 409  
   embroidery of Lesage, 2:350  
   fashion dolls, 2:38  
   first modern fashion designers, 2:36  
   hats, 2:412  
   haute couture, 2:189  
   international reputation, 2:51  
   Japanese influence, 2:265  
   perfume, 3:36  
   *robes de style*, 3:349  
   swimwear, 3:252  
   tailored suits, 3:260  
 Laotian dress, 1:98, 2:194  
 Lapland, 2:98  
 Laroche, Guy  
   Alaïa, Azzedine, designs by, 1:32  
   perfume, 3:36  
   Valentino and, 3:388  
 Larrikinism, 1:102  
 Laser tattoo removal, 3:270  
 Lastex, 2:139, 140, 3:253, 254  
 Lasting machines, 3:167, 195  
 Lastol, 1:405  
*Lastovitsy*, 3:122–123  
 Lasts, 3:165  
 Latin American fashion, **2:333–335**  
   *See also* South American dress  
 Latino style, **2:335–337**  
   *quinceañeras*, 1:349  
   subcultures, 3:235  
   zoot suits, 3:468  
 Lauder, Estée, 1:299, 3:36  
 Laundromats, 2:339–340  
 Laundry, **2:337–340**, 3:162  
 Laurel, Alicia Bay, 2:102  
 Lauren, Ralph, **2:340–341**, 341  
   *ao dai* style, 1:62  
   Asian influence, 3:15  
   boutiques, 3:102  
   business suits, 3:238  
   color and brand identification, 1:283  
   costume design, 2:85, 222  
   counterfeit labels, 2:217  
   discount stores, 3:102  
   eyewear, 1:434  
   hand knitted designs, 2:310  
   Hilfiger, Tommy, comparison with,  
     2:213  
   leather, 2:345

- masculinized fashions for women, 2:133  
 perfume, 3:36  
 polo shirts, 3:52  
 Scottish textiles, 3:149  
 sport shirts, 3:213  
 sportswear, 3:217, 221  
 t-shirts, 3:343  
 vintage fashion, 3:400  
 Windsor, Duke of, 3:438  
 Laver, James, 1:328, 2:18, **2:341–343**, 3:365, 460  
 Lavigne, Professor, 2:377  
 Law, J., 3:214  
 Lawn tennis. *See* Tennis costumes  
 Lawrence, Gertrude, 1:6, 2:46  
 Laws of Omar, 2:286  
 Layering  
   Cashin, Bonnie, 1:232  
   Sub-Saharan African social class and status, 1:24  
   wedding garments, 1:243  
 Layette, 1:259  
 Le Brun, Charles, 3:118  
 Le Jeune, Watteau, 2:66  
*Le Pouf*, 1:429  
 Le Roy, Edward, 3:2  
 Leadership masks, 2:392–393  
 Leane, Shaun, 2:399  
 Leather and suede, **2:343–345**, 344  
   animal prints as alternative to, 1:60  
   Cashin, Bonnie, 1:232  
   Fendi, 2:76–78  
   fetish fashion, 2:81  
   Gucci, 2:109–110, 155–156  
   Hermès, 2:201–202  
   Mugler, Thierry, 2:428, 428  
   tanning, 3:264–265  
   Vuitton, Louis, 3:408  
 Leather Apparel Association (LAA), 2:345  
 Leather Industries of America (LIA), 2:345  
 Leblanc, Lauren, 3:235  
 Leczinska, Maria, 1:421  
 Lee, Gypsy Rose, 3:230  
 Lee, William, 2:308–309, 311  
 Lee jeans, 2:240, 273  
 Leech, John, 1:228  
 Legal and judicial costume, **2:346–349**, 3:111  
 Léger, Ferdinand, 3:413, 435  
 Leggings, 3:353  
 Legislation. *See* Regulations  
 Legnani, Pierina, 3:43  
 Leiber, Judith, **2:349**, 3:157  
 Leigh, Dorian, 2:64, 3:242  
 Leighton, Fred, 1:305  
 Leisure, conspicuous, 3:391  
 Leisurewear  
   Australia, 1:103  
   Levi Strauss, 2:353  
   social change, 2:23  
   *See also* Casual wear; Sportswear  
 Leloir, Heloise, 2:66  
 Lelong, Lucien  
   art deco, 1:77  
   Dior's work for, 1:366  
   haute couture and World War II, 2:187  
 Lemarié, André, 1:254  
 Lemur, 1:62  
 Lenglen, Suzanne, 2:291, 3:23, 278  
 Lenzing AG, 3:82  
 Leotards, **2:349–350**  
 LePape, Georges, 2:49, 67  
 Les Couturiers associés, 2:188  
 Lesage, Albert, 3:404  
 Lesage, François, 1:254, **2:350–351**  
 Lesbians  
   androgyny, 2:32  
   dandyism, 1:344  
   masculine dress, 2:31  
   radical feminism, 2:32  
   *See also* Homosexuality and fashion  
 Leser, Tina, 2:36, 398, 3:254  
 Lettie Lane paper dolls, 1:121  
 "Letty Lynton" dress, 3:323  
 Levi Strauss, **2:351–353**, 352  
   advertising, 2:29  
   brands and labels, 1:187  
   denim, 1:359–360  
   Indian denim production, 2:240  
   jeans, 2:273–274, 275  
   teenage fashion, 3:276  
 Levine, Beth, 3:136  
 Levy, Maurice, 2:358  
 Lewinsky, Monica, 2:121  
 Leyendecker, J. C., 2:29  
 Li Yu, 2:108  
 LIA (Leather Industries of America), 2:345  
 Liberace, 3:338  
 Liberian masks, 2:392  
 Liberman, Alexander, 1:19, 3:30  
 Liberty & Co., **2:353–355**  
   artistic dress, 3:412  
   cotton, 1:308  
   Liberty, Arthur Lasenby, 1:12  
   Muir, Jean, 2:429  
   retailing, 2:362  
 Licensing  
   Amies, Hardy, 1:49, 51  
   Armani, Giorgio, 1:67, 68  
   Balmain, Pierre, 1:117  
   Beene, Geoffrey, 1:139–140  
   Blass, Bill, 1:160  
   brands and labels, 1:187–188  
   Cardin, Pierre, 1:222, 224–225  
   Chalayan, Hussein, 1:249  
   couture houses, 2:126  
   couture houses, post World War II, 1:403  
   Ellis, Perry, 1:406  
   fashion industry, 2:52  
   Fendi, 2:77, 78  
   film fashions, 1:11  
   Grès, Madame, 2:152  
   Halston, 2:168  
   haute couture, 2:187–188  
   Hollywood styles, 2:222  
   Hugo Boss, 2:229–230  
   James, Charles, 2:258  
   Madonna, 2:71  
   Missoni, 2:416  
   Paris fashion, 3:20  
   Pucci, Emilio, 3:65  
   Quant, Mary, 3:460, 462  
   Rabanne, Paco, 3:78  
   Saint Laurent, Yves, 3:131  
 Licht, Judith, 2:54  
 Lichtenstein, 3:435  
 Life cycle, fashion, 2:22–23  
 Lifestyle brands, 2:50  
 Lifestyle designing, 2:36  
 Light  
   psychedelic fashion, 3:63  
   UV resistant finishes, 3:33–34  
 Lightning Fastener Company, 3:466  
 Lil' Kim, 2:216, 217, 3:408  
 Linard, Stephan, 2:432  
 Lincoln, Abbey, 1:25–26, 27  
 Lindberg, Peter, 3:243  
 Lindbergh, Peter, 1:372  
 Lindy hop, 1:335  
 Linen, 2:355, **3:55–356**  
   cambric, batiste, and lawn, 1:217  
   Coptic, 3:298  
   Greece, ancient, 1:55  
   Middle East, 3:303  
 Lingerie, 2:356, **3:56–357**  
   Gaultier, Jean-Paul, 2:128  
   Patou, Jean, 3:23  
   satin, 3:418–419  
   stockings, 3:223–225  
   *See also* Corsets  
 Linguistics  
   Barthes, Roland, 1:128  
   Baudrillard, Jean, 1:132–133  
 L'Interdit (perfume), 3:36  
 Linton tweeds, 3:347  
 Lip piercing, 1:167  
 Lipkin, Janet, 3:413  
 Lipstick, **2:357–358**  
 Lipstick lesbians, 2:32  
 Liripipes, 2:178  
 List, Adele, 2:413  
 Liston, Melba, 1:25  
 Literature and fashion  
   Balzac, Honoré de, 1:117–119  
   dandyism, 1:343  
   Japanese traditional dress, 2:267  
   Proust, Marcel, 3:60–62  
 Lithographic posters, 2:28  
 Little black dress, **2:358–360**, 359  
   Chanel, Gabrielle (Coco), 1:250–251  
   cocktail dresses, 1:274  
   costume jewelry, 1:302  
   1920s fashion, 3:349

- Little Women* (film), 2:85  
 Livery, 3:369, 372, 444  
*Living on the Earth* (Laurel), 2:102  
 Llanover, Lady, 2:98  
 Location sensors, 3:273  
 Lock-stitch sewing machines, 3:167  
 Locke, Edie Raymond, 2:40, 53  
 Locke, John, 1:256  
 Locketts, 2:442, 443–444  
 Loewe, 3:206  
 Log wood, 1:389  
 Logos, **2:360–361**  
   Cardin, Pierre, 1:225  
   Fendi, 2:77  
   Hilfiger, Tommy, 2:214  
   hip-hop style, 2:217  
   Lacoste, Rene, 3:278  
   Lauren, Ralph, 2:340–341  
 Logos  
   Nike, 3:197  
   ski clothing, 3:189  
   sport shirts, 3:213  
   sweatshirts, 3:246  
   t-shirts, 3:343  
   tennis costumes, 3:278  
   Vuitton, Louis, 3:408  
   *See also* Brands and labels  
 Loincloths, 1:52  
 Loom, **2:362–364**, 363  
 London, England  
   sweatshops, 3:247  
   tapestries, 3:266  
 London fashion, **2:361–362**  
   aesthetic dress, 1:11–13  
   Biba, 1:153, 153–154  
   blazers, 1:160  
   boutiques, 1:180–181  
   business suits, 3:237–238  
   cross-dressing, 2:29  
   dandyism, 1:341, 344–346  
   debutantes, 1:348  
   Diana, Princess of Wales, 1:363–364  
   duffle coats, 1:384–385  
   gentlemanly style, 1:345–346  
   hats, 2:413–414  
   Liberty & Co., 2:353–354  
   masquerade and masked balls, 2:3, 393–394  
   men's preference for, 3:19  
   modernists, 1:345  
   museums, 2:60  
   New Romantics, 2:432  
   1960s, 3:351  
   Savile Row, 3:142–143  
   secondhand clothes, 3:153–154  
   Spanish dress, influence on, 3:205  
   tailoring, 3:263–264  
   Teddy Boys, 2:432  
   teenage fashion, 3:276  
   Twiggy, 3:354–355  
   vintage fashion, 3:399  
   women's tailored suits, 3:259–260  
   *See also* Youthquake fashion; Specific designers  
 London Fog, 3:80  
*London Labour and London's Poor* (Mayhew), 3:154  
 Long, Emile, 2:164  
 Long, William Ivey, 3:323  
 Long ties, 2:446  
 Looms, **2:362–364**, 363  
   African weaving, 3:280  
   Byzantine textiles, 3:287  
   Central American and Mexican, 1:38–39  
   Coptic, 3:298  
   handwoven textiles, 2:174  
   Jacquard, 3:415, 424  
   multiphase looms, 3:424  
   shuttleless, 3:424  
   Southeast Asia, 3:313, 314  
 Loop-manipulated braiding, 1:185  
 Lopez, Antonio, 2:49  
 Lopez, Jennifer, 2:335  
*Lorettes*, 1:355  
 Los Angeles Museum of Art, 2:61  
 Louis, Jean, 2:83  
 Louis XIII, 3:357–358  
 Louis XIV  
   caricature, 1:225  
   court dress, 1:312, 3:18–19  
   high heels, 2:204  
   jewelry, 2:284  
   lace, 2:325  
   Le Brun tapestry, 3:118  
   mantua, disapproval of the, 2:380  
   perfume, 3:35  
   political use of fashion, 1:423–424  
   promotion of French products, 1:401  
   ribbons, 3:106  
   shoes, 3:172  
   wigs, 2:163, 3:430  
   women's shoes, 3:175  
 Louis XV  
   court dress, 1:313  
   jewelry, 2:283–284  
   tea gown, 3:271–272  
 Louis XVI, 2:132  
 Loungewear, 3:13–15  
 Low riders, 2:336  
 LSD, 3:62–63  
 Lucas, Otto, 2:413  
 Lucet work, 1:185  
 Luchford, Glen, 2:65  
 Lucile, 1:113, **2:364–365**  
   art deco, 1:77  
   fashion models, 2:58, 59  
   fashion shows, 2:68  
   lingerie, 2:357  
 Lucite, 2:172  
 Lufthansa, 3:372  
 Luggage  
   design, 3:334  
   Hermès, 2:201–202  
   Vuitton, Louis, 3:408  
*Lurik*, 3:314  
 Lüscher Color Test, 1:282  
 Lutens, Serge, 2:375  
 LVMH  
   accessories, 2:127  
   Fendi, 2:78  
   Givenchy, House of, 2:142  
   haute couture, 2:188, 189  
   Lacroix, Christian and, 2:327–328  
   McQueen, Alexander, 2:400  
 Lycra, 2:140, 141, 3:279  
 Lydig, Rita de Acosta, 3:6  
 Lye, 2:337  
 Lynes, George Platt, 2:64  
 Lyocell, 3:82, 83
- ## M
- Macaroni dress, 2:15, **367–369**  
 Macdonald, Julien  
   Fashion and Textile Museum, 3:105  
   Minogue, Kylie and, 1:239  
   rubber wear, 3:121  
 Machine-made lace, 2:326  
 Macintosh, Charles, 3:9, 79, 80, 121  
 Mackie, Bob, 2:369, **369–370**  
   appliqué, use of, 1:64  
   *Barbie* designs, 2:38  
   spangles, 3:203  
 MacPherson, Elle, 3:244  
 Macramé, 2:312  
 Macy's  
   Cinema Shop, 1:11, 2:222  
   millinery, 2:184, 185  
 Madagascar, 2:297  
 Madame Demorest's Emporium, 1:358–359  
 Madder dyes, 1:388–389  
*Made in USA* label, 2:320, 3:156, 157  
 Madison, Dolley, 2:86  
 Madonna, **2:370–372**, 371, 372  
   corsets, 2:81, 3:419  
   costume jewelry, 1:305  
   demimonde, influence of the, 1:357  
   Dolce and Gabbana, relationship with, 1:372  
   Ford, Tom, fashions of, 1:240  
   licensing, 2:71  
   Meisel, Steven and, 2:401–402  
   music and fashion, 2:430  
   music videos, 1:336  
   1980s fashion, 3:352  
   stockings, 3:225  
   tiaras, 1:327  
 Magazines  
   fan, 2:222  
   *Godey's Lady's Book*, 2:147–149  
   Latino, 2:335  
   punk, 3:69  
   *See also* Fashion magazines and publications  
 Magdalena, Maria, Countess of Hardegg, 3:119  
 Magic



- beads, 1:134  
 brooches and pins, 2:98  
 cache sexe, 1:211  
 color, 2:44  
 cosmetics, 1:294  
 embroidery, 1:409  
 jewelry, 2:277, 278  
*lurik*, 3:314  
 masks, 2:388–392  
 Middle Eastern Islamic dress, 2:403  
 North African dress, 1:17–18  
 occult dress, 3:1–2  
 rings, 3:108–109  
 Southeast Asian textiles, 3:317  
 Magruder, Gail and Jeb Stuart, 3:108  
 Maiden Form, 1:190, 191  
 Mail-order  
   ready-to-wear, 3:87  
   shopping via, 3:180  
 Maimonides, 2:284  
 Mainbocher, 2:372–374  
   Vreeland, Diana, patronage of, 3:406  
   Windsor, Duchess of, 3:438  
 Mainstream culture, 1:168–169  
 Makarova, Nadezhda, 1:287  
 Makeba, Miriam, 1:25  
 Makeover shows, 2:71  
 Makeup. *See* Cosmetics  
 Makeup artists, 2:374–375  
   *See also* Theatrical makeup  
 Malaysian dress  
   batik creation, 1:130  
   Islamic dress, 2:253  
   traditional clothing, 1:93–94  
 Maldives, 3:310  
 Mali  
   bogolan, 1:169–170  
   masks, 2:390, 391, 391  
 Mallarmé, Stéphane, 2:375, 375–377  
 Malloy, Doug, 1:166  
*Malo*, 1:126  
 Mambo, 1:103  
 Mamluk sultanate, 2:405–406  
 Man-made fibers, 2:82  
 Manchus, 1:264, 2:108  
 Mandarin Squares, 1:264, 265  
 Mandarina Duck, 1:4  
 Mandela, Nelson, 1:347  
 Mandelli, Mariucci, 1:33  
 Mango, 3:206  
 Manicuring, 2:437–439  
 “Manifeste du Futurisme” (Marinetti), 2:118  
 Mannequins, 2:377–379, 378  
   *See also* Fashion models  
 Mansfield, Richard, 1:200  
 Mantillas, 2:193  
 Mantua, 2:379–380  
 Manuals, tailoring, 3:204, 262  
 Manuel, Henri, 2:62  
 Manufactured fibers, 2:82  
 Manufacturers  
   labeling laws, 2:319–320  
   merchandising, 2:57–58  
   retailer/manufacturer tension, 2:50–51  
   *See also* Fashion industry; Production and manufacturing  
 Mao suits, 1:83, 265, 266, 280, 2:380–381, 381  
 Mao Zedong, 2:381  
 Maori people, 1:244–245  
 Mapplethorpe, 2:226  
 Maps, 1:41  
*Maqamat al-Hariri*, 2:405  
 Marcel wave, 2:160, 163–164  
*Mardi gras*, 2:393–394  
 Mardi Gras debutantes, 1:349  
 Margaine-Lacroix, 2:38  
 Margiela, Martin, 2:381–383  
   Belgian fashion, 1:143  
   fashion shows, 2:125  
   French fashion system, 2:265  
   Hermès, 2:202  
   1990s fashion, 3:353  
   secondhand clothes, 3:155  
   unisex clothing, 3:384  
   vintage fashion, 3:399  
 Maria, Henrietta, 2:131  
 Maria Clara ensemble, 1:94–95  
 Mariachi dress, 2:336  
 Marie, Gerald, 3:243  
 Marie Antoinette  
   Bertin, Rose and, 1:151  
   chemise, 1:254  
   hairdressers, 2:160  
   pastoral look, 2:184  
 Marii technique, 2:399  
 Marimekko, 2:383–385, 384  
 Marinetti, Filippo Tommaso, 2:118  
 Market-research firms, 2:37  
 Marketing, 2:57–58  
   Barbie, 1:121–122  
   brands and labels, 1:187–188  
   color, 1:282–283  
   cosmetics, 1:298, 299  
   designer jeans, 2:274  
   ecclesiastical dress, 1:399  
   fashion designers, 2:36  
   garment trade, 2:126–127  
   girdles, 2:140  
   Hawes, Elizabeth, 2:190  
   Hilfiger, Tommy, 2:213, 214  
   Internet, 2:208  
   Lang, Helmut, 2:329  
   Lauren, Ralph, 2:341  
   Marks & Spencer, 2:386  
   Missoni, 2:416  
   Paquin, House of, 3:17  
   Poiret, Paul, 3:46–47  
   ready-to-wear, 3:88  
   sewing machines, 3:158  
   sneakers, 3:196–197  
   teenage fashion, 3:275–277  
   thong underwear, 2:121–122  
   Worth, Charles Frederick, 3:447–448  
   Zoran, 3:468  
   *See also* Advertising; Merchandising; Public relations  
 Marks & Spencer, 2:385–386  
 Marni, 2:433  
 Marriage attire. *See* Wedding costumes  
 Marshall Fields, 3:434  
 Martial arts, 1:146  
 Martin, Charles, 2:49, 67  
 Martin, Harrison, 3:459  
 Martin, Richard, 2:19, 20, 60–61  
 Martine school, 3:46  
 Marx, Karl, 2:386–388, 387, 3:198  
 Mary, Queen of England, 1:325–326  
 Mary, Queen of Scots, 2:3  
 Mary Jane shoes, 3:170  
 Mary Stuart, Queen of Scotland, 3:116  
 Maryhill School, 2:39  
 Masai  
   headdresses, 2:194  
   jewelry, 1:22  
 Masculinity  
   Australian dress, 1:102, 103  
   bodybuilding and sculpting, 1:165–166  
   children’s clothing, 1:259  
   codpiece, 1:276  
   cross-dressing, 1:322  
   in dance, 1:340  
   de-masculinization of sacred dress, 3:95–96  
   department stores, 1:362  
   Flügel, J.C., 2:91  
   Gaultier, Jean-Paul, 2:128  
   gay men, 2:31–32  
   kilts, 2:302  
   lesbian dress, 2:31  
   men’s underwear, 3:361  
   morality and, 2:14–15  
   Roma dress, 3:115  
   Saint Laurent, Yves, 3:133  
   t-shirts, 3:342  
   theory of fashion, 2:24  
   women’s fashion and, 1:344  
 Masks, 2:388–393, 389, 390, 391  
   ballet costumes, 1:116  
   Halloween, 2:167  
   theater, 3:324  
 Masquerade and masked balls, 2:3–5, 2:393–394  
   *See also* Clothing, costume and dress  
 Mass customization, 2:208–209  
 Mass media, 2:24, 3:276  
 Mass production  
   buttons, 1:208–209  
   democratization of fashion, 2:25  
   department stores, 1:361–362  
   ecclesiastical dress, 1:399  
   fashion industry and, 2:50–51  
   McCardell, Claire, 2:396  
   ready-to-wear, 3:86  
   shirtwaists, 1:164  
   shoes, 3:167, 172  
   sportswear, 3:221  
   watches, 3:410  
 Massachusetts, 3:167, 170  
 Massaro, Raymond, 1:254

- Master P, 2:217  
 Master's jacket, 2:150  
 Matching jewelry sets, 2:442  
 Materialism, 2:217  
 Materials  
   canes and walking sticks, 1:219–220  
   equestrian costume, 1:411–412  
   Gernreich, Rudi, 2:137  
   Rabanne, Paco, 3:77  
   techno, 2:207–208  
   theatrical costumes, 3:323–324  
 Maternity apparel, 2:132  
 Maternity dress, **2:394–396**, 395  
 Matignon Agreement, 1:252  
 Matisse, Henri, 1:72, 398, 3:5  
 Mattachine Society, 2:32, 136  
 Mattel Corporation, 1:121–123  
 Mattotti, Lorenzo, 2:49  
 Matzlinger, Jan, 3:167, 195  
 Maurier, George du, 1:228  
 Maximilian armor, 1:70  
 Maxwell, Vera  
   recognition of, 2:36  
   sportswear, 1:3  
 Mayo, Edith, 2:86  
 Mazurka dress, 1:339  
 Mazza, Valeria, 2:335  
 McCall, James, 3:25–26  
 McCall patterns, 3:27  
 McCardell, Claire, **2:396–398**, 398  
   American fashion, 2:51  
   American Look, 2:36, 3:20  
   Dahl-Wolfe photography of fashions  
     by, 1:334  
   eyewear, 1:434  
   Fashion Group, 3:57  
   fashion of, 2:397  
   Gernreich, Rudi, influence on, 2:136  
   jumpers, 2:291  
   leotards, 2:349  
   1940s fashion, 3:350  
   plaid, 3:39, 39  
   popover dress, 2:273  
   sportswear, 1:3, 2:456, 3:218, 221  
   swimwear, 3:254  
   t-shirts, 3:343  
   tunics with leotards, 2:415  
   Vionnet, Madeleine, influence of,  
     3:404  
 McCartney, Stella  
   fashion illustrators, collaboration with,  
     2:49  
   London fashion, 2:362  
   Madonna's collaboration with, 2:372  
 McClellan, Elisabeth, 2:18  
 McDean, Craig, 2:65  
 McDonald, Julien  
   Givenchy, House of, 2:142  
   London fashion, 2:362  
 McDowell, Shellie, 2:185  
 McFadden, Mary, **2:398–399**  
   embroidery, 1:409  
   polyester, 3:53  
 McFlimsey, Flora, 2:39  
 McKay Closing Machine, 3:167  
 McKinney, Henry Nelson, 3:171  
 McLaren, Malcolm  
   on fashion, 2:54  
   music and fashion, 2:433  
   1970s fashion, 3:352  
   punk, 3:67–68, 455  
   Westwood, Vivienne and, 3:427–429  
 McMenamy, Kristin, 2:401  
 McNamara's Lace, 2:312  
 McNeill, Elsie Lee, 2:114  
 McQueen, Alexander, **2:399–400**  
   art and fashion, 3:414  
   corsets, 1:292  
   duffle coats, 1:384–385  
   fashion shows, 2:70, 125  
   Givenchy, House of, 2:142  
   haute couture, 2:189  
   London fashion, 2:362  
   Oriental belly-dance costumes,  
     influence of, 1:338  
   Paris fashion showings, 3:20  
   Scottish textiles, 3:149  
   sweaters, 3:245  
   tailoring, 3:263  
   tartan, 3:268  
   tweeds, 3:348  
   vintage fashion, 3:400  
 Measurement  
   corsets and waist measurements,  
     3:328–329  
   cutters, 1:331  
   Paris Point system, 3:165  
   shoemaking, 3:164–165  
   tailoring, 3:262–263  
   yarn size, 3:456, 458  
 Mecca, 2:216  
 Mechanization  
   looms, 3:424–425  
   spun yarn, 3:282  
   tanning, 3:265  
   textile industry, 3:320  
 Medical profession, 1:220  
 Mediterranean countries  
   folk dress, 2:100  
   shared influences, 3:286  
 Mediterranean style, 1:371–372  
 Meiji era  
   Japanese fashion, 2:260–261  
   kimonos, 2:302, 304–305  
   traditional dress, 2:270–271  
   yukata, 3:463  
 Meiners, 3:323  
 Meisel, Steven, **2:400–402**, 401  
   Dolce & Gabbana, 1:372  
   fashion photography, 2:65  
   supermodels, 3:243  
   Versace, Donatella and, 3:396  
 Mellen, Polly, 2:40  
 Mellinger, Frederick, 2:121  
 Mello, Dawn, 2:156  
*Memento mori*, 2:283, 3:110  
 Men  
   beards and mustaches, 1:54–55,  
     136–137, 2:162, 237  
   bodybuilding and sculpting, 1:165–166  
   cross-dressing clubs, 1:321–323, 323  
   debuts, 1:349  
   department store customers, 1:362  
   fashion and, 2:13  
   fetishism, 2:80–81  
   hairstyles, 1:120  
   handbags, 2:170  
   shaving, 1:119, 136  
   veiling, 1:369, 370  
 Mende, 1:242  
 Mendelsohn, Erich, 1:362  
 Mendl, Lady, 3:438  
 Menichetti, Roberto, 1:202  
 Menkes, Suzy, 1:239, 2:54  
 Mennonites, 2:133, 3:98, 99  
 Men's dress and fashion  
   Afro hairstyle, 1:27  
   Albini, Walter, 1:34–35  
   Amies, Hardy, 1:50–51  
   ballet costumes, 1:340  
   Balzac's descriptions of, 1:117–119  
   bark cloth, 1:126  
   Baudelaire, Charles, 1:131  
   Brooks Brothers, 1:197–199  
   Central American and Mexican, 1:40  
   codpiece, 1:276  
   corsets, 2:132  
   cosmetics, 1:300  
   dress for success, 1:378–380  
   effeminacy, 2:14–15, 24, 31, 368  
   fashion magazines, 2:56  
   fashion plates, 2:66, 67  
   Flügel, J.C., 2:91  
   formal wear, 2:110–112, *111*, *112*,  
     3:345, 438  
   gay influence, 2:32  
   Hawe, Elizabeth, all-male fashion show  
     of, 2:190  
   high heels, 2:204, 205  
   Indonesia, *1:94*  
   Iran, 2:248–249  
   Islamic, 2:251–252  
   Italian fashion, 2:255  
   Jewish dress, 2:284, 285–286  
   Korea, 2:314–315, *315*, *316*  
   Macaroni dress, 2:15, 367–368  
   pockets, 3:41  
   Roma, 3:115  
   Savile Row, 3:142–143  
   street style, 3:225–228  
   striped cloth, 3:229–230  
   tailoring, 3:261–264  
   twentieth century, 3:348–353  
   Windsor, Duke of, 3:436–438  
   Youthquake fashion, 3:461  
   *See also* Specific designers; Specific  
     items of clothing  
   Men's hats, **2:177–181**, *178*, *179*, *180*,  
     *181*

- Men's shoes, 3:171, **171–3:172**  
 Mercedes Australian Fashion Week, 1:102  
 Merchandising, **2:57–58**  
*See also* Marketing  
 Merchant ships, 3:86  
 Mercier, Laura, 2:375  
*Le Mercure galant* (magazine), 2:54–55  
 Mercury space program, 3:202  
 Merlina, N. A., 3:125  
 "Merry Widow," 1:292  
 La Mésangère, 2:66  
 Mesh bags, 2:171–172  
 Mesopotamian dress, 1:52–53  
 Mestral, George de, 1:270  
 Metal, 3:77  
 Metallic fibers, 2:82  
 Metallurgy, 1:43  
 Metaphor, fashion as, 2:368, 376  
 Metcalf, Betsy, 2:411  
 Metissacana Web site, 3:255, 257  
 Metzner, Sheila, 2:65  
 Mexican dress, **1:37–42**  
   ecclesiastical dress, 1:397  
   headdresses, 2:194  
   Vaquero dress, 1:314, 315  
 Meyer, Baron de, 2:226, 228  
 MFA (Multifiber Arrangement), 3:81, 317–318  
 Michael, John, 3:263  
 Michahelles, Ernesto  
   unisex clothing, 3:383–384  
   Vionnet, Madeleine and, 3:403  
 Michahelles, Ernesto and Ruggero, 2:118, 119  
 Michel, Maison, 1:254  
 Microfibers, 2:207, **2:402**, 2:461–462  
 Middle Ages  
   academic dress, 1:1  
   aprons, 1:65  
   armor, 1:69–70  
   barber surgeons, 2:160  
   barbers, 1:119  
   boots, 1:173  
   brooches, 1:196–197  
   children's shoes, 3:170  
   doublets, 1:374–375  
   ecclesiastical dress, 1:396  
   embroidery, 1:407–408  
   European dress, 1:418–420, 419  
   hairstyles, 2:162  
   handbags and purses, 2:169–170  
   helmets, 2:196, 197  
   historical studies of fashion, 2:17  
   individual and self, 2:26  
   jewelry, 2:280–282  
   laundry, 2:337  
   legal and judicial costume, 2:346  
   masculinity and femininity, 2:24  
   masquerade and masked balls, 2:393  
   men's footwear, 3:171  
   men's headwear, 2:177–178  
   outerwear, 3:7–8  
   quilted clothing, 3:74  
   rings, 3:109  
   Spanish dress, 3:203–204  
   striped cloth, 3:229  
   sumptuary laws, 3:238–239  
   tailoring, 3:261–262  
   tapestries, 3:266  
   theatrical costumes, 3:322  
   trousers, 3:339–340  
   used clothing, 3:85  
 Middle class, 2:425–426  
 Middle Eastern dress, **2:402–409**  
   belly-dance costumes, 1:338–339  
   veils, 3:392–394  
*See also* Arab dress; Islamic dress  
 Middle Eastern textiles, **3:302–305**  
 Miele, Carlos, 2:334  
 Migratory bird protection, 2:74–75  
 Milan, Italy, 1:34, 2:255  
 Military style, **2:409–410**, 3:240  
 Military uniforms, **3:364–369**, 365, 367  
   Abbasid era, 2:405  
   armor, 1:69–71  
   belts, 1:146  
   berets, 1:149–150  
   blazers, 1:160  
   boots, 1:174  
   boxer shorts, 1:181  
   Burberry, 1:201–202  
   buttons, 1:208  
   camouflage cloth, 1:218–219  
   canes and walking sticks, 1:220  
   coats, 1:273  
   doublets, 1:374  
   duffle coats, 1:384  
   footwear, 3:166–167  
   Han dynasty, 1:262  
   helmets, 2:197  
   Highland dress, 3:148  
   Japan, 2:268–270  
   kilts, 2:301  
   Mamluk sultanate, 2:405  
   Ottoman Empire, 2:406  
   parkas, 3:21  
   protective clothing, 3:58–60  
   reenactors, 3:93–94  
   ribbons, 3:106, 107  
   Rome, ancient, 1:58  
   Safavid era, 2:407  
   sandals, 3:136  
   t-shirts, 3:341  
   Tang dynasty, 1:263  
   tartan, 3:267–268  
   trench coats, 3:79, 80  
 Miller, Annie Jenness, 1:14  
 Miller, Hinda, 3:361  
 Miller, Lee, 2:64  
 Miller, William, 2:17  
 Miller and Rhoads, 1:406  
 Milliners, **2:411–415**, 412, 3:334–335  
*See also* Hats; Head wear; Headdresses  
 Minagawa, Makiko, 2:418  
 Minaudières, 2:349  
 Mineral dyes, 1:389  
 Mineral tanning, 3:265  
 Ming dynasty, 1:264, 265, 2:107–108, 3:295  
 Mingei movement, 2:270–271  
 Minh Hanh, 1:62  
 Mini Crini collection, 3:429  
 Miniature portraits, 1:206–207  
 Minimalism  
   Baudelaire, Charles, 1:131  
   Cardin, Pierre, 1:224  
   costume jewelry, 1:305  
   Halston, 3:20  
   Lang, Helmut, 2:329–330  
   Steele, Lawrence, 3:222  
   Vionnet, Madeleine, 3:402–403  
   Zoran, 3:468  
 Miniskirts, **2:415–416**  
   Courrèges, André, 1:309  
   hemlines, 2:199–200, 3:461  
   vinyl, 3:400  
   Youthquake fashion, 3:460  
 Minkowitz, Norma, 3:413  
 Minnelli, Liza, 2:401  
 Minoan dress, 1:55  
 Minorities  
   Chinese, 1:84, 264  
   cosmetics, 1:299  
 Minshall, Peter, 1:231  
 Minsky brothers, 3:230–231  
 Mirabella, Grace, 2:40, 3:405  
 Miracle plays, 3:322  
 Mirman, Simone, 2:185  
 Mirror work, 1:409  
 Mirrored sunglasses, 3:241  
 Mischka, Badgley, 2:372  
 Miss Dior (perfume), 3:36  
 Missionaries  
   indigenous people's dress, 1:277  
   Pacific Islands, 1:95–97  
   religion and dress, 3:99  
 Missoni, **2:416**  
   knitwear, 2:310  
   Milan, Italy, 2:255  
   sweaters, 3:245  
 Miu Miu, 2:103  
 Mix-and-match. *See* Separates  
 Miyake, Issey, **2:417–420**  
   activewear, 1:4  
   ethnic style, 1:417  
   fashion photography and, 2:65  
   fashions of, 2:417, 419  
   future of fashion, 2:117  
   Japonisme, 2:272  
   knitwear, 2:310  
   1980s fashion, 3:352  
   perfume, 3:36  
   t-shirts, 3:343  
   technology and fashion, 2:208  
   Vionnet, Madeleine, influence of, 3:404  
   Western awareness of, 1:283



- Mizrahi, Isaac  
 fashion television, 2:71  
 fur fashion, 2:116  
 Klein, Calvin and, 2:307  
 retro style, 3:104
- Moccasins, 3:168
- Mod style, 2:415
- La Moda* (magazine), 2:334
- La mode*, 2:13
- La mode illustrée* (magazine), 2:55
- Modeling agencies, 2:59
- Modeling and Grooming School, 3:354, 355
- Modern art  
 change and, 1:75  
 Delaunay, Sonia, 1:352
- Modern dance, 1:284, 339–340
- Modern Merchandising Bureau, 1:11
- Modern Primitives, **2:420–421**  
 body piercing, 1:168  
 implants, 2:235  
 subcultures, 3:236  
 tattoos, 3:270
- Modern Tiara, 1:326
- Modernism  
 Courrèges, André, 1:309–310  
 dandyism, 1:345  
 fashion photography, 2:62  
 Italian futurist fashion, 2:118–119  
 jewelry, 2:283  
 philosophy of fashion, 3:186  
 window displays, 3:434  
 Woolf, Virginia, 1:344
- Modernity  
 Baudelaire, Charles, 1:131–132  
 Benjamin, Walter, 2:387  
 dandyism, 1:343  
 identity, 2:35  
 Lanvin, Jeanne, 2:332  
 veils, 3:393  
 Western fashion and non-Western societies, 2:24
- Modernization  
 Japanese fashion, 3:300  
 legal and judicial costume, 2:348  
 Middle Eastern Islamic dress, 2:408  
 tanning, 3:265
- Les modes* (journal), 2:55
- Modesty  
 bathing costumes, 3:251  
 Christian dress codes, 2:14–15  
 Flügel, J.C., 2:91  
 Hawaiian dress, 1:96–97  
*hijab*, 2:210–211  
 Islamic dress, 1:369–370  
 Jewish dress, 2:284–286  
 missionaries and indigenous people's dress, 1:277  
 penis sheaths, 3:29  
 religion and dress, 3:97, 98  
 veils, 3:393
- Modistes. *See* Milliners
- Mods  
 dandyism, 1:345  
 music and fashion, 2:430  
 1960s fashion, 3:351  
 Quant, Mary, 3:73  
 revival, 1:310–311  
 teenage fashion, 3:276  
 vinyl as fashion fabric, 3:400
- Moers, Ellen, 1:343
- Mogul Empire, 1:87
- Mohair, **2:421**, 3:303
- Mohawk haircuts, 3:67, 68
- Mohawk Warrior outfit, Cher's, 2:370
- Moholy-Nagy, László, 2:28
- Moisture control, 3:272–273
- Moldavian folk dress, 2:95
- Molding materials, 2:209
- Molloy, John T., 1:237, 378–379, 3:352
- Molyneux, Edward, 3:465
- Momoyama period, 2:268
- Monastic dress, 2:396–397
- Mongol Empire, 1:264
- Mongolia  
 felt, 2:75–76  
 history of dress, 1:85  
 swaddling, 1:256
- Monocles, 1:432
- Monroe, Marilyn, 2:222, 371, 3:15
- Monsieur* (magazine), 2:56
- Montagu, Lady Mary Wortley, 3:117, 118
- Montana, Claude  
*ao dai* style, 1:62  
 fashion shows, 2:70  
 fetish fashion, 2:82  
 haute couture, 2:188, 189  
 Jones, Stephen and, 2:414  
 Lanvin, House of, 2:330  
 leather, 2:345  
 little black dress, 2:360  
 retro-futurism, 2:430  
 retro style, 3:103
- Montecristi fino-fino, 2:180
- Montesquieu, Robert de, 3:61
- Monzani, Sarah, 2:375
- Moon knives, 3:164–165
- Moore, Colleen, 2:89
- Moore, Doris Langley, 1:329, **2:421–422**
- Moral standards and dress, 3:49
- Morality  
 flappers, 2:88  
 lingerie, 2:356–357  
 women's dress, 2:13–14
- Moran, Gertrude, 3:15
- Moran, Gussy, 3:278
- Mordant dyes, 1:389
- Moreau, J. M., 2:66
- Morehouse, Marion, 2:62
- Mori, Hanae, 2:263, **2:422–423**, 3:6
- Morley, Ruth, 3:323
- Mormons, 3:96
- Morning dress, 2:111
- Morocco, 2:286–287
- Morris, Bernadine, 2:416, 3:440
- Morris, Jane, 1:12, 13
- Morris, Ken, 1:231
- Morris, Robert Lee, 1:305
- Morris, William  
 artistic dress, 3:412  
 Bohemian dress, 1:172  
 ecclesiastical dress, 1:397  
 gothic influence, 2:219
- Morrissey, Peter, 1:102, 103
- Morton, Digby, 1:50, 3:347
- Moschino, Franco, **2:423–425**  
 appliqué, use of, 1:64  
 caricature, 1:229  
 Courrèges, André, influence of, 1:311  
 folkloric theme, 1:339  
 handbags, 2:173  
 Italian fashion, 2:255  
 trench coats, 3:80
- Moss, Jean, 2:310
- Moss, Kate, 1:202, 238–239, 2:47, 203, 3:243, 244
- Motherhood and Nazi ideology, 2:9
- Mothers of the Plaza de Mayo, 2:334
- Mothproofing finishes, 3:34
- Motifs  
 adinkra cloth, 1:7  
*adire*, 1:9  
 Adrian, 1:11  
 African, 1:27  
 animal prints, 1:60  
 batik, 1:129–130  
 Bhutanese textiles, 3:311  
 bogolan, 1:170  
 boubous, 1:175–176  
 button, 1:207–209  
 Byzantine textiles, 3:287–288  
 Central Asian textiles, 3:289, 290–291  
 Chinese dragon robes, 3:113  
 dragon robes, 1:264  
 Eastern European folk dress, 2:94, 96  
 embroidery, 1:409  
 fans, 2:6  
 folklore look, 2:102  
 Fortuny, Mariano, 2:113–114  
 Gaultier, Jean-Paul, 2:128  
 Hawaiian shirts, 2:189  
 ikat, 2:232  
 Japonisme, 2:271  
 jewelry, 2:278, 279  
 Korean dress, 2:316  
 Middle Eastern textiles, 3:302–303  
 North African dress, 1:18  
 Pucci, Emilio, 3:64–65  
 rings, 3:109  
 Russian folk, 1:286  
 sarongs, 3:141  
 scarves, 3:143  
 Seydou, Chris, 3:159–160  
 shawls, 3:12, 161  
 Southeast Asian textiles, 3:313–314, 315  
 swimwear, 3:254

Tam, Vivienne, 1:418  
 yukata, 3:463  
 Motion detection, 3:273  
 Motion in fashion, 1:353–354, 3:403  
 Motivation  
   change in dress style, 2:343  
   Macaroni dress, 2:367–368  
   reenactors, 3:93–94  
 Motorcycle gangs, 3:228, 233, 234  
 Mouret, Roland, 3:105  
 Mourning dress, **2:425–427**  
   black, symbolism of, 3:119  
   black ribbon, 3:107  
   *memento mori*, 2:282, 3:110  
   rings, 3:110  
   *See also* Funerary and burial rituals  
 Mrs. *Doubtfire* (film), 2:130  
 MTV, 2:71  
 Muffs, 2:427, **427–428**  
 Mugler, Thierry, **2:428–429**  
   Alaïa, Azzedine and, 1:32  
   embroidery of Lesage, 2:351  
   fashion shows, 2:70  
   fetish fashion, 2:81  
   1980s fashion, 3:352  
   retro-futurism, 2:430  
   retro style, 3:103  
   rubber dress, 2:80  
   tailored suits, 3:261  
 Muhammad, 2:404  
 Muir, Jean, **2:429**  
   Scottish fashion, 3:149  
   Youthquake fashion, 3:462  
 Mukanda, 2:391–392  
 Mulder, Karen, 3:243  
 Multifiber Arrangement (MFA), 3:81,  
   319–320  
 Multifunctional clothing, 2:117, 3:59–60  
 Munkacsy, Martin, 1:104, 2:40, 63–64  
 Munter, Gabriele, 1:172  
 Murakami, Hideo, 3:408  
 Murakami, Takashi, 2:49  
 Murex dye, 3:287  
 Murjani International, 2:213  
 Muromachi period, 2:268, 3:300  
 Musafar, Fakir, 1:167–168, 2:420–421  
 Musée de la Mode et du Costume, 2:60  
 Musée de la Mode et du Textile, 2:60  
 Museo Ferragamo, 2:79  
 Museum of Costume, 2:60, 422  
 Museum of Costume at Platt Hall, 1:329  
 Museum of the City of New York, 2:61  
 Museums  
   Chinese textiles, 3:295–296  
   Costume Institute, 3:407  
   Fashion and Textile Museum, 3:105  
   fashion doll collections, 2:38  
   Hat Making Museum, 2:185–186  
   Museo Ferragamo, 2:79  
   Museum of Costume, 2:422  
   Museum of Costume at Platt Hall,  
     1:329  
   Smithsonian Institution, 2:86–87

*See also* Exhibits  
 Music and fashion, **2:429–434**  
   celebrities, 1:240  
   fashion icons, 2:47  
   fashion television, 2:71  
   goth, 2:150–152  
   Hilfiger, Tommy, 2:213–214  
   Madonna, 2:370–372, 371  
   music videos, 1:336  
   *See also* Specific types of music  
 Musical theater, 1:335–336, 340  
 Muslim dress. *See* Islamic dress  
 Muslim lands, 2:285, 286–287  
 Muslin, 2:434, **434–435**  
 Mustaches. *See* Beards and mustaches  
 Muumuus, 1:415  
 My Fair Lady (musical), 1:340  
 “My Own” (Perfume), 3:388  
 Myra’s *Journal of Dress and Fashion*, 2:55  
 Mystery plays, 3:322  
 Mythology, 1:102  
 Myths  
   body piercing, 1:166  
   bra-burning, 1:192  
   corsets, 1:291, 292  
   Empire style, 1:411  
   fashion, 2:13, 19  
   femininity, 2:14  
   tight-lacing, 3:328

## N

Nadja handbag, 2:173  
 Nagel, Morris, 2:136  
 Nagle, Eleanor, 2:52  
 Nail art, **2:437–439**  
 Naismith, James, 3:381  
 Nakedness. *See* Nudity  
 Nalbinding, 2:308  
 Nambokuchō period, 2:268  
 Nana (Zola), 1:356, 413  
 Napoleon and Josephine  
   court dress, 1:312–313  
   head wreath, 1:324–325  
   jewelry, 2:282  
   perfume, 3:35  
 Napoleonic Wars, 3:366–368  
 Nappa skins, 2:344–345  
 Napping, 2:88, **439–440**  
 Naphthol dyes, 1:388  
 Nara period, 2:266–267  
 Nasif, Malak Hifni, 2:212  
 National Academy of Design, 1:140, 141  
 National Button Society, 1:209  
 National Debutante Cotillion and  
   Thanksgiving Ball, 1:348  
 National dress  
   Bhutan, 3:311  
   Indonesia, 2:295  
   kimonos, 2:302–303  
   Maldives, 3:310  
   Russia, 3:123  
   Scotland, 2:301–302  
 National Institutes of Fashion  
   Technology (NIFT), 2:240  
 National mourning, 2:425  
 Nationalism  
   black cultural, 1:28, 30  
   carnival dress, 1:231  
   colonialism and, 1:280  
   fascist and Nazi dress, 2:8–12  
   folk dress, 2:93, 97  
   India, 2:239  
   Italian futurist fashion, 2:118–119  
   kente, 2:300  
   Latin American fashion, 2:333–334  
   veiling, 2:212–213, 3:393  
 Native American dress  
   beading, 1:409  
   beads, 1:135  
   body piercing, 1:166–167  
   ceremonial costumes, 1:243–244  
   cross-dressing, 1:319  
   embroidery, 1:409  
   ethnic dress, 1:416  
   European elements of dress, 1:424  
   feathers as hair adornment, 2:159  
   footwear, 3:173  
   hair forks, 2:159  
   hippie style and, 2:218  
   history of dress, 1:42–45  
   Latin America, 2:333  
   masks, 2:390–391  
   oil tanning, 2:344  
   rites of passage costumes, 1:241–242  
   South America, 1:45–46  
   textiles, 3:307  
   war bonnets, 2:75, 194  
 Natural dyes. *See* Dyes, natural  
 Natural look  
   cosmetics, 1:299  
   fascist and Nazi dress, 2:9–11  
 Natural materials, 2:279, 282  
 Naturalism, 3:176  
 Nature masks, 2:389–390  
 Naudet, Simone, 1:275  
 Nautical style, **2:440–441**  
 Navajo dress, 3:332  
 Naval clothing. *See* Sailors  
 Nazi dress, **2:8–12**  
 Near East, 3:307  
 Neck elongation, 1:431, 431  
 Neckerchiefs, 2:445–446  
 Necklaces and pendants, 1:302–305,  
   **2:441–444**  
 Neckties and neckwear, **2:444–447**, 445,  
   446  
   Hermès, 2:202  
   Lauren, Ralph, 2:340  
   Windsor, Duke of, 3:437  
 Neckwear. *See* Neckties and neckwear  
 Needle lace, 2:325  
 Needles, **2:447–449**  
 Nefertari’s tomb, 1:53

- Negative sanctions  
 group norm violation, 3:49  
 religion and dress, 3:99
- Negligées. *See* Lingerie
- Negrin, Henriette, 2:113
- Negritude, 1:28
- Nehru jackets, 1:224, **2:449–451**, 450
- Neiman Marcus, 1:158
- Neiman Marcus Award  
 Cashin, Bonnie, 1:232  
 Dior, Christian, 2:452  
 Fogarty, Anne, 2:92  
 Pucci, Emilio, 3:64
- Neo-Edwardianism, 2:220
- Neo-Modernist style, 1:345
- Neoclassicism  
 Empire style, 1:410–411  
 Hoyningen-Huene, George, 2:228  
 music and fashion, 2:430–431  
 retro style, 3:103  
 revivals, 2:220  
 rococo style, 1:424–425  
 shawls, 3:160–161
- Neolithic period, 3:305
- NEP (New Economic Policy), 1:286
- Nepal, 1:90, 3:310–311
- Nestle, Joan, 2:31
- The Netherlands  
 batik, 1:130, 3:282  
 folk dress, 2:98  
 Sri Lanka, influence on, 1:89  
 textile trade, 3:309
- Netted bags, 2:171
- Netting, hair, 2:159
- Neumann, Vera, 1:406
- Nevill, Bernard, 1:268, 2:354
- The New Avengers* (television show), 3:235
- New Balance, 3:196, 215
- New Economic Policy (NEP), 1:286
- New Guinea  
 cosmetics, 1:293, 1:294  
 fashion education, 2:42  
 masks, 2:389, 392  
 rites of passage costumes, 1:241
- New Look, 2:451, **451–453**  
 Adrian's refusal to follow, 1:11  
 Balmain, Pierre, 1:116–117  
 caricature of, 1:229  
 cocktail dresses, 1:275  
 costume jewelry, 1:304  
 evening dresses, 1:429  
 fashion icons, 2:47  
 fashion models, 2:59  
 fashion transformation, 2:26  
 Fath, Jacques, rejection of by, 2:73  
 film and fashion, 2:83  
 Fogarty, Anne, adaptation of, 2:92  
 girdles, 2:140  
 Givenchy, Hubert de, 2:141  
*Gone with the Wind*, influence of, 2:222  
 haute couture, 2:187  
 hemlines, 2:199
- high heels, 2:205
- imperviousness to street style, 3:225
- La Belle Epoque influence, 1:367
- Mainbocher, influence of, 2:374
- 1940s fashion, 3:350
- Paris fashion, 3:20
- reaction to, 1:366
- retro style, 3:103
- shirtwaists, 3:164
- stockings, 3:224
- tailored suits, 3:261
- New Romantics, 2:432
- New York City  
 apparel industry, 3:86, 87  
 fashion photography, 2:64  
 garment factories, 2:51  
 Seventh Avenue, 3:155–157  
 sweatshops, 3:248, 248  
 youth culture, 3:274
- New York Dolls, 3:67
- New Zealand  
 ceremonial costumes, 1:244–245  
 fashion education, 2:42
- Newhouse, Ronnie Cooke, 2:49
- Newspapers. *See* Fashion journalism
- Newton, Helmut, 2:453, **453–454**  
 Dolce & Gabbana, 1:372  
 fetish fashion, 2:81  
 French *Vogue*, 2:65, 3:20  
 little black dress, 2:360  
 tuxedos, 3:345  
 Twiggy, photographing of, 3:355
- Newton, Huey P., 1:347
- Nicholas I, 3:125
- NIFT (National Institutes of Fashion Technology), 2:240
- Nigeria  
*agbada*, 1:30–32  
 ceremonial costumes, 1:245  
 ecclesiastical dress, 1:397, 399  
 ethnic style, 1:19–20  
 gender and dress, 2:130, 131  
 headdresses, 2:194  
 identity and dress, 1:243  
 masks, 2:389  
*pagnes*, 3:11  
 rites of passage costumes, 1:242  
 textiles, 3:280, 281
- Nightgowns, **2:454–455**
- Nijinsky, Vaslav, 1:115, 2:250
- Nike  
 hip-hop style, 2:216–217  
 logo, 2:360, 361  
 outsourcing of production, 2:143, 145  
 sneakers, 3:196–197  
 sport shirts, 3:213  
 sport shoes, 3:215
- Nikolais, Alwin, 1:340
- Nikon, Patriarch, 3:123
- 1910s  
 fashion, 3:348–349
- 1920s  
 Chanel, Gabrielle (Coco), 1:250–251
- cocktail dresses, 1:274
- cosmetics, 1:298
- costume jewelry, 1:302–303
- earrings, 1:393
- fancy dress, 2:4
- fashion, 3:349
- flappers, 2:88–89
- girdles, 2:138
- hair bobbing, 2:164, 165
- hemlines, 2:199
- Patou, Jean, 3:22–24
- skirts, 3:190
- swimwear, 3:252, 253
- teenage fashion, 3:275
- Vionnet, Madeleine, 3:403–404
- women's shoes, 3:177
- 1930s  
 Chanel, Gabrielle (Coco), 1:252
- cocktail dresses, 1:274–275
- costume jewelry, 1:302–303
- earrings, 1:393
- fashion, 3:349–350
- girdles, 2:138–139
- handbags and purses, 2:172
- Schiaparelli, Elsa, 3:145–147
- swimwear, 3:252
- tailored suits, 3:260
- women's shoes, 3:177
- 1940s  
 bobby soxers, 3:275
- earrings, 1:393–394
- fashion, 3:350
- Schiaparelli, Elsa, 3:147
- swimwear, 3:253–254
- See also* World War
- 1950s  
 African American women's hairstyles, 1:25
- Australian subcultures, 3:234
- Chanel, Gabrielle (Coco), 1:252–253
- democratization of clothing, 3:382–383
- earrings, 1:394
- fashion, 3:350–351
- fashion icons, 2:47
- folklore look, 2:103
- girdles, 2:140–141
- gloves, 2:147
- hairstyles, 2:164–165
- handbags and purses, 2:172
- music and fashion, 2:433
- Schiaparelli, Elsa, 3:147
- striptease, 3:231
- sunglasses, 3:241
- swimwear, 3:254
- t-shirts, 3:342
- teenage fashion, 3:275
- 1960s  
 advertising, 2:28
- Afro hairstyle, 1:25–26
- Afrocentric fashion, 1:28–30
- Biba, 1:153–154
- bikinis, 1:156
- boutiques, 1:179–181



- Chanel, Gabrielle (Coco), 1:253–254  
 costume jewelry, 1:304, 305  
 Courrèges, André, 1:309–310  
 dashikis, 1:346–347  
 earring, 1:394  
 evening dress, 1:429  
 fashion, 3:351  
 fashion icons, 2:47  
 folklore look, 2:103  
 German revival, 3:152  
 girdles, 2:141  
 hairstyles, 2:165  
 handbags and purses, 2:172  
 hatlessness, 2:185  
 miniskirts, 2:415  
 paper dresses, 3:15–16  
 parkas, 3:21  
 psychedelic fashion, 3:62–64  
 Pucci, Emilio, 3:65–66  
 retro style, 3:103  
 Rykiel, Sonia, 3:128  
 sandals, 3:136  
 space age style, 3:199–200  
 sunglasses, 3:241  
 swimwear, 3:254  
 tie-dyeing, 3:327–328  
 vinyl as fashion fabric, 3:400  
 waistcoats, 3:410  
 women's shoes, 3:177
- 1970s  
 Afro hairstyle, 1:26–27  
 Afrocentric fashion, 1:28–30  
 casual business dress, 1:236–237  
 costume jewelry, 1:305  
 earrings, 1:394  
 fashion, 3:351–352  
 fashion icons, 2:47  
 fashion photography, 2:65  
 gay men, 2:32  
 hairstyles, 2:165  
 handbags and purses, 2:172  
 Kamali, Norma, 2:296  
 midi-skirts, 2:200  
 punk, 3:66–69  
 sunglasses, 3:241  
 unisex clothing, 3:383  
 Von Furstenberg, Diane, 3:405–406  
 wearable art, 3:413–414  
 Westwood, Vivienne, 3:428  
 women's shoes, 3:177  
 women's trousers, 3:341
- 1980s  
 costume jewelry, 1:305  
 dress for success, 1:378–380  
 earrings, 1:394  
 fashion, 3:352–353  
 fashion icons, 2:47  
 fashion photography, 2:65  
 handbags and purses, 2:172–173  
 Kamali, Norma, 2:296  
 Klein, Calvin, 2:306–307  
 miniskirt revival, 2:416  
 Miyake, Issey, 2:417–418
- Smith, Paul, 3:192  
 Spanish fashion, 3:206  
 wearable art, 3:414  
*Women's Wear Daily*, 3:440
- 1990s  
 casual business dress, 1:236  
 earrings, 1:394–395  
 fashion, 3:353  
 fashion photography, 2:65  
 handbags and purses, 2:173
- Nineteenth century  
 advertising, 2:27–28  
 aesthetic dress, 1:12–14  
 art and fashion, 1:73  
 ballet costumes, 1:115  
 bonnets and hats, 2:411–412  
 breeches, 1:194–195  
 bustles, 1:204–205  
 buttons, 1:208–209  
 caricature and fashion, 1:228–229  
 children's clothing, 1:257–258  
 children's shoes, 3:170  
 coats, 1:273  
 corsets, 1:290–292  
 cosmetics, 1:296  
 court dress, 1:313  
 cross-dressing, 1:322  
 demimonde, 1:354–357  
 Demorest, Madame, 1:358–359  
 department stores, 1:361  
 dress reform, 2:15–16  
 earrings, 1:392–393  
 equestrian costume, 1:412  
 European and American dress, 1:425–427  
 European aristocratic dress, 2:131–132  
 evening dresses, 1:428–429  
 eyeglasses, 1:432–433  
 fancy dress, 2:3–4  
 fans, 2:7–8  
 fashion dolls, 2:38  
 fashion illustrators, 2:49  
 fashion magazines, 2:55  
 fashion photography, 2:62  
 fashion plates, 2:66–67  
 fashion shows, 2:67–68  
 gloves, 2:146–147  
*Godey's Lady's Book*, 2:147–149  
 hairstyles, 2:163–164  
 handbags and purses, 2:171  
 high heels, 2:205  
 historical studies of fashion, 2:17–18  
 industrial revolution and mass production, 2:25  
 Iranian dress, 2:408  
 jackets, 2:257  
 Japanese fashion, 2:260–261  
 Japonisme, 2:271  
 lace, 2:326  
 Latin American fashion, 2:333–334  
 laundry, 2:339  
 Laver, James, 2:343  
 London fashion, 2:361–362
- masquerade and masked balls, 2:393–394  
 maternity dress, 2:395  
 men's hats, 2:179  
 military uniforms, 3:366–368  
 mourning dress, 2:425–426  
 neckwear, 2:445–446  
 needle production, 2:448–449  
 nightgowns, 2:454–455  
 occupational uniforms, 3:372  
 Orientalism, 3:5  
 outerwear, 3:9  
 Paris fashion, 3:19  
 petticoats, 3:37  
 ready-to-wear, 3:86, 87  
 ribbons, 3:107  
 rings, 3:110  
 self and dress, 1:379–380  
 sewing machines, 3:157–158  
 shawls, 3:161  
 stockings, 3:223  
 subcultures, 3:232–233  
 suits, 3:237  
 swimwear, 3:251–252  
 tailoring, 3:262–263  
 tea gowns, 3:271–272  
 textile workers, 3:320  
 theatrical costumes, 3:323  
 tight-lacing, 3:328–329  
 trendsetters, 3:335  
 tweeds, 3:347  
 umbrellas and parasols, 3:358–359  
 underwear, 3:341  
 Valentino's references to, 3:389  
 waistcoats, 3:409  
 waltz and fashion, 1:334  
 wearable art, 3:412–413  
 wigs, 3:430–431  
 women's hats, 2:183  
 women's shoes, 3:175–176  
 women's tailored suits, 3:259
- Nipple piercing, 1:167  
 Nirvana, 2:153, 154  
 Nivi style saris, 3:138  
 Nkrumah, Kwame, 1:20, 2:300  
 No theater, 2:268, 388–389, 390  
 Nobility  
 English, 1:402  
 French, 1:402  
 Russian dress, 3:123–124  
 See also Royal and aristocratic dress  
 Noel, Laure, 2:66  
 Nomads  
 Central Asian textiles, 3:288–291  
 felt, 2:75–76  
 Middle Eastern Islamic dress, 2:408–409  
 Nomex, 3:59  
 Non-western cosmetics, 1:292–295  
 Non-western dress and fashion  
 ethnic jewelry, 2:442–443  
 extreme fashion, 1:431  
 Modern Primitives, 2:420–421  
 modernity, 2:24  
 wedding costumes, 3:425

- Nonconformity  
 Quaker dress, 1:381  
 t-shirts, 3:342
- Nonstore retailers, 3:102
- Nonwoven textiles, 1:125–126,  
**2:455–456**
- Norell, Norman, **2:456–458**  
 cocktail dresses, 1:275  
 Dahl-Wolfe photography of fashions  
 by, 1:334  
 perfume, 3:36  
 spangles, 3:203
- Norfolk jackets, 2:257, 3:216
- Norms, violation of, 3:49
- North African dress, **1:16–19**, 212
- North African textiles, 3:280–281
- North American indigenous peoples,  
**1:42–45**, 44, 416
- Northern European folk dress, 2:98–99
- Northrop, J. H., 3:424
- Norton Simon Industries (NSI), 2:168
- Norway  
 court dress, 1:313  
 folk dress, 2:98
- Nose piercing, 1:166, 167
- Nostalgia. *See* Retro styles; Revivals,  
 historic; Vintage fashion
- Notebook on Cities and Clothes* (Wenders),  
 3:453
- Novello, Giuseppe, 2:77
- Novelties  
 bikinis, 1:156  
 canes and walking sticks, 1:220  
 costume jewelry, 1:303  
 fans, 2:8  
 paper dresses, 3:15–16  
 rings, 3:110  
 yarns, 3:458
- NSI (Norton Simon Industries), 2:168
- Nuba, 1:295
- Nudism, **2:458–460**
- Nudity, **2:460–461**  
 Clark, Ossie, 1:268  
 Flügel, J.C., 2:91  
 g-strings and thongs, 2:121–122  
 modern-dance costumes, 1:339–340  
 Newton, Helmut, 2:454  
 occult dress, 3:1  
 Penn's nude studies, 3:31  
 striptease, 3:230–231  
 underwear, 3:360
- Nuns, 3:99
- Nureyev, Rudolph, 3:131
- Nurmesniemi, Vuokko Eskolin, 2:384
- Nutter, Tommy, 3:143, 238, 263
- Nylon, **2:461–462**  
 backpacks, 2:172  
 girdles, 2:139–140  
 as high-tech fiber, 3:272  
 microfiber, 2:402  
 parkas, 3:21  
 ski clothing, 3:188  
 swimwear, 3:254
- underwear, 3:361  
 windbreakers, 3:433
- O**
- O Boutique, 1:203
- Obi, 2:303–304
- Object-based studies of fashion, 2:18–20
- O'Brien, Glenn, 2:49
- Obsession (perfume), 2:307, 3:36
- Occult dress, **3:1–2**
- Occupational health, 2:45
- Occupational uniforms, 3:369, **369–373**,  
 370, 371, 3:444  
*See also* Working-class dress
- Oceania, 2:43
- Odetta, 1:25, 27
- Odom, Mel, 2:39
- Oestergaard, Heinz, 3:371–372
- Off-price-stores, 3:101–102
- Off-shore apparel production, 3:88
- Ogden, Jessica, 3:399
- Oil industry, 2:252–253
- Oil tanning, 3:264
- Oilcloth, 2:440
- Oilskins, **3:2–3**
- O'Keefe, Georgia, 1:344
- Okuboyejo, Betty, 1:9
- Oldenburg, Claes, 3:435
- Oldham, Todd, 2:71, 3:244
- Olefin fibers, **3:3**
- Olins, David, 2:28
- Olympics, 3:218–219, 378
- L'ombrelle, le gant, le manchon* (Uzanne),  
 3:384
- O'Neal, Ron, 1:27
- Onitsuke, Kihachiro, 3:196
- Online fashion, **2:61–62**
- Onozuka, Akira. *See* Zucca
- Open-end spinning, 3:212
- Oppenheim, Meret, 3:146
- Optical fibers, 3:273
- Opus Anglicanum*, 1:407–408
- Orientalism, **3:4–7**  
 ballet costumes, 1:115  
 Ferragamo, Salvatore, 2:79  
 Fortuny, Mariano, 2:113–114  
 historical studies of fashion, 2:17  
 Poiret, Paul, 1:338, 3:45  
*See also* Japonisme
- Orlando* (Woolf), 1:344
- Ornamentation. *See* Embellishments
- Les ornements de la femme* (Uzanne),  
 3:384
- Orrick, Mildred  
 leotards, 2:349  
 plaid, 3:39
- d'Orsay, Alfred Guillaume Gabriel,  
 Count, 1:341–342
- Orth, Maggie, 3:273
- Osmerkina, Tatiana, 1:288
- Ôsode* costumes, 2:268
- Ostrick, bag, 2:78
- Otero, Caroline, 1:355
- Otherness and hip-hop, 2:215
- Ottoman Empire  
 caftans, 1:212  
 embroidery, 1:409  
 Islamic dress, 2:406–407  
 silk production, 3:303
- Our Dancing Daughters* (film), 2:89
- Out of Africa* (film), 2:85
- Outerbridge, Paul, 2:28
- Outerwear, **3:7–10**  
 t-shirts as, 3:342  
 underwear as, 3:192, 361  
 windbreakers, 3:433
- Outlet stores, 3:102
- Outsourcing, 2:143–144
- Overalls, 2:273
- Overcoats, 1:272–273, 3:9
- Overgowns, 3:8
- Overton, Anthony, 1:297
- Owens, Jesse, 3:196
- Owens, Rick, 2:372
- Oxford University, 1:1–2
- Ozbek, Rifat  
 Oriental belly-dance costumes,  
 influence of, 1:338  
 Rastafarian style, 2:432
- Ozenne, Jean, 1:365
- P**
- P. Diddy. *See* Combs, Sean
- Pachuco style, 2:336
- Pacific Islands  
 bark cloth, 1:125–126  
 ethnic dress, 1:415  
 history of dress, 1:93–97  
 tattooed man, 1:93
- Packaging  
 Hermès products, 2:202  
 pins, 3:38  
 stockings, 3:224
- Packing, 3:144, 145
- Paduang tribe, 1:431, 431
- Paganism. *See* Occult dress
- Page, Anita, 2:89
- Pagnes*, **3:11–12**
- Pain, 2:421
- Painters  
 Barbier, Georges, 1:123–124  
 bohemian dress, 1:170–172  
 Delaunay, Sonia, 1:352
- Paisley, **3:12–13**, 149, 161, 303
- Pajamas, **3:13–15**, 14  
 India, 1:88  
 women's, 2:455
- Pakistan  
 burqas, 1:89  
 history of dress, 1:86, 88  
*salwar-kameez*, 3:133–134  
 textiles, 3:308–309  
 veils, 3:392, 393
- Palazzo pajamas, 3:14

- Paleolithic period  
 cache-sexe, 1:211  
 needles, 2:447–448  
 textiles, 3:305
- Palestinian dress  
*kaffiyeh*, 2:293  
 veiling, 2:212–213
- Pallium, 3:330
- Pallu*, 3:139, 140
- Palmer, Alexandra, 2:20
- Paltrow, Gwyneth, 2:84
- Panama hats, 2:180
- Panizon, Madeleine, 3:47
- Pantalets, 1:258
- Pantaloons, 1:194, 3:340
- Pantie girdles, 2:139
- Panties, **3:15**
- Pants. *See* Trousers
- Pantsuits  
 evening dress, 1:429  
 Gaultier, Jean Paul, 3:261  
 1960s, 3:351  
 tailored, 3:260  
 Youthquake fashion, 3:461
- “Paper doll” dress, 2:92
- Paper dolls, 1:121, 2:38
- Paper dresses, **3:15–16**, 3:77
- Paper patterns, 1:358–359
- Papini, Luciano, 1:34
- Paquin, House of  
 Cardin, Pierre, 1:223  
 Worth, House of, competition with, 3:449
- Paquin, Jean-Marc, 2:188
- Paquin, Jeanne, **3:16–18**  
 art and fashion, 1:73  
 art nouveau, 1:76  
 demimonde, 1:356  
 fashion of, 3:17, 18, 19  
 fashion shows, 2:67–68  
 first modern fashion designers, 2:36  
 international reputation, 2:51  
 Iribe, Paul, hiring of, 2:250  
 models, use of, 2:58  
 Orientalism, 3:5  
 society dresses, 3:348  
 suede, 2:345  
 Le syndicat de défense de la grande couture française, 1:216  
 tailored suits, 3:260
- Paramount Pictures, 2:191–192
- Parasols. *See* Umbrellas and parasols
- Paris, France  
 department stores, 1:361  
 fashion museums, 2:60  
 masquerade and masked balls, 2:393–394  
 sweatshops, 3:247
- Paris, Piet, 2:49
- Paris Exposition des Arts Décoratifs et Industriels, 3:47
- Paris Exposition Universelle, 1:216
- Paris fashion, **3:18–21**
- Barbier’s illustrations, 1:123–124
- Belgian designers, acceptance of, 2:265
- Chambre Syndicale de la Couture Parisienne, 3:57
- cocktail dresses, 1:274–275
- Comme des Garçon, 1:283
- demimonde, 1:354–357
- fashion leadership, 2:25
- fashion photography, 2:62, 65
- fashion shows, 2:67–68
- first modern fashion designers, 2:36
- hats, 2:183–185, 412–413
- international reputation, 2:51
- Japanese designers, acceptance of, 2:262*t*, 263–265, 264*f*
- mannequins, use of, 2:377, 379
- Miyake, Issey, invitation of, 2:417–420
- la mode*, 2:13
- origins, 1:402
- press coverage, 2:54
- sapeurs*, 3:137
- Spanish dress, influence on, 3:205
- Treacy, Philip, invitation of, 3:335
- turn of the twentieth century, 3:348
- twentieth century, 3:348–353
- Uzanne, Octave, writing of, 3:384–385
- Viktor & Rolf, 3:397–398
- window displays, 3:434–435
- women’s tailored suits, 3:260
- Women’s Wear Daily*, 3:439
- See also* Specific designers
- Paris Point system, 3:165
- Parkas, 2:243, 243–245, 244, **3:21**, 433
- Parker, Sarah Jessica, 1:157
- Parker, Suzy, 2:64, 396, 3:242
- Parmelee, Maurice, 2:458, 459
- Parsons, Frank Alvah, 2:18
- Parsons School of Design, 2:456–457
- Parthian dress, 2:249
- Partridge, Frederick, 1:326
- Pashm*, 1:234–235
- Pashmina. *See* Cashmere and pashmina
- Das Passagenwerk* (Benjamin), 1:147
- Paste-resist dyeing, 3:301
- Pastoral look, 2:182, 184
- Patch, Thomas, 1:226
- Patchett, Jean, 3:31
- Patchwork, 2:267
- Patents  
 brands and labels, 1:187  
 brassieres, 1:190  
 crinolines, 1:317  
 cuprammonium rayon, 3:82  
 electric tattooing implements, 3:270
- Fortuny, Mariano, 2:113
- Levi Strauss, 1:360
- looms, 3:424
- Macintosh, Charles, 3:79
- mannequins, 2:377
- paper patterns, 3:86
- riveted work pants, 2:351–352
- safety pins, 3:129
- sewing machines, 3:86–87, 157, 195
- umbrellas, 3:358, 359
- zippers, 3:465
- See also* Inventions
- Patiala suits, 3:133–130
- Patitz, Tatjana, 3:243
- Patola*, 2:232
- Patou, Jean, **3:21–25**  
 art deco, 1:77  
 cocktail dresses, 1:274  
 costume jewelry, 1:302  
 embroidery of Lesage, 2:350  
 fashion shows, 2:68, 69  
 flappers, 2:88  
 folklore look, 2:102  
 haute couture, 2:188  
 jumpers, 2:291
- Lacroix, Christian and, 2:327
- milliners, 2:412
- models, use of, 2:59
- 1920s fashion, 3:349
- swimwear, 3:252
- tailored suits, 3:260
- Vreeland, Diana, patronage of, 3:406
- Patriotism  
 cosmetics, 1:298–299  
 costume jewelry, 1:304
- Patterning, 3:280
- Patterns and pattern-making, 3:25, **25–29**, 26, 27  
 crochet, 1:318  
 cutting, 1:330–331  
 dress patterns, 1:358–359  
 film fashions, 1:11  
 tailoring, 3:263
- Paulette, Madame, 2:413
- Paulin, Guy, 2:327
- Pava, Ricardo, 2:335
- Pavlova, Anna, 1:114
- PCMs (Phase change materials), 2:208
- Peacock Revolution, 3:80
- Pearce, G. L., 3:214
- Pearl, Cora, 1:356
- Pearls, 2:280, 281–282, 442, 444
- Pears, John, 3:263
- Pearson, Easton, 1:103
- Peasant dress. *See* Folk dress; Rural dress
- Peele, Beverly, 2:401
- Le peintre de la vie moderne* (Baudelaire), 1:343
- Pekalongan sarongs, 1:130
- Pelham; or, The Adventures of a Gentleman* (Bulwer-Lytton), 1:343
- Peltier effect, 3:274
- Pendants. *See* Necklaces and pendants
- Pendleton shirts, 2:154
- Penile augmentation, 3:40
- Penile implants, 2:234
- Penis sheaths, **3:29–30**
- Penn, Irving, **3:30–32**  
 fashion editors and, 2:40  
 Miyake, Issey and, 2:65  
 style of, 2:64



- Penney, J. C., 2:168, 3:73  
 People for the Ethical Treatment of Animals (PETA), 2:345  
 Pepys, Samuel, 3:236–237  
 Perception and color, 1:281–282  
 Perestroika, 3:127  
 Peretti, Elsa, 1:305  
 Perez, Thierry, 2:49  
 Perfectionism  
   Brummell, George, 1:341  
   Ellis, Perry, 1:407  
 Perforated patterns, 3:27  
 Performance art, 3:398  
 Performance finishes, **3:32–34**  
 Perfumes, **3:34–37**  
   Armani, Giorgio, 1:67  
   Capucci, Roberto, 1:221  
   Chanel, Gabrielle (Coco), 1:250, 253  
   Chanel, House of, 1:254  
   Comme des Garçon, 1:284  
   De La Renta, Oscar, 1:351  
   Dior, Christian, 1:366  
   Dolce & Gabbana, 1:371  
   Fath, Jacques, 2:73  
   Fendi, 2:77, 78  
   Gigli, Romeo, 2:138  
   Givenchy, Hubert de, 2:141  
   Grès, Madame, 2:152  
   Halston, 2:169  
   Hilfiger, Tommy, 2:213  
   India, 2:237  
   Klein, Calvin, 2:307  
   Lang, Helmut, 2:329  
   Maison Balmain, 1:117  
   Mugler, Thierry, 2:428  
   Patou, Jean, 3:23–24  
   Poiret, Paul, 3:46  
   Rabanne, Paco, 3:78  
   Saint Laurent, Yves, 3:131, 132  
   Schiaparelli, Elsa, 3:145, 146  
   Sub-Saharan Africa, 1:22  
   Valentina, 3:388  
   Valentino, 3:389  
   Versace, Gianni, 3:396  
   Viktor & Rolf, 3:397  
   Westwood, Vivienne, 3:429  
 Perkin, William Henry, 1:387  
 Permanent-press fabrics, 3:32–33  
 Permanent waves, 2:163–164  
 Perniola, Mario, 2:460  
 Perry, Fred, 2:360, 3:52, 279  
 Peruvian dress, 1:46–47, 47, 48, 3:111–112, 283, 284  
 PETA (People for the Ethical Treatment of Animals), 2:345  
 Peter I, 3:124–125  
 Petri, Ray, 2:32  
 Petticoats, **3:37–38**  
 Phase change materials (PCMs), 2:208  
 Phat Farm, 2:275, 3:276  
*The Philadelphia Story* (film), 3:388  
 Philip IV, 3:118  
 Philippines, 1:94–95, 398  
 Phillips, Beryl Dean, 1:398  
 Phillips, Mary Walker, 2:310  
*Philosophie der Mode* (Simmel), 2:18  
 Philosophy of fashion. *See* Fashion philosophy; Theory of fashion  
 Photographic advertising, 2:28  
 Photography. *See* Fashion photography  
 Piaggi, Anna, 1:239, 2:49  
 Picabia, Francis and Gabrielle, 3:47, 146  
 Picasso, Pablo, 1:72, 3:413  
 Piecework, 3:86  
 Piecing, 3:75  
 Piel, Denis, 2:65  
 Pierce, Charles, 2:29, 31  
 Piercing. *See* Body piercing  
 Pigment dyes, 1:388  
 Pignet, Robert  
   Dior's work for, 1:365–366  
   embroidery of Lesage, 2:350  
   Les Couturiers associés, 2:188  
 Pile fabrics, 2:320  
 Pile weave, **3:415–416**  
 Pilgrims, 1:424  
 Pillbox hat, 1:246, 2:183  
*Piña*, 3:314–315  
 Pinault, François, 3:133  
 Pince-nez, 1:433  
 Pined PINET, 2:205  
 Pingat, Émile, 1:73  
 Pink, 3:146  
 Pins, **3:38–39**  
   *See also* Brooches and pins; Safety pins  
 Pinto, Fernando, 1:231  
 Pinups, 3:225, 250  
 Piocelle, John, 2:185  
 Pioneer Corporation, 2:207  
 Pire, P., 3:126  
 Pith helmets, 2:197  
 Plaid, **3:39–40**  
   folk dress, 2:97–98  
   kilts, 2:300–302  
   Scottish dress, 3:148  
 Plain weave, 3:298, 299, **3:416–417**, 417, 423  
 Plaiting, 3:312  
 Planché, James Robinson, 2:17  
 Plastic and cosmetic surgery, **3:40–41**  
   body shaping, 1:165  
   branding removal, 1:187  
   implants, 2:233–235  
 Plastic buttons, 1:209  
 Plate armor, 1:69–70  
 Platform footwear, 3:169, 175  
 Playtex girdles, 2:140  
 Pleats  
   dress shirts, 1:383  
   Miyake, Issey, 2:418  
*The Plum in the Golden Vase* (novel), 2:108  
 Plume bag, 2:171  
 Plunkett Greene, Alexander, 3:72  
 Ply yarns, 3:458  
 Pocket watches, 3:410  
 Pockets, 2:170–171, **3:41–42**  
 Poem-dresses, 1:352  
 Poets  
   Baudelaire, Charles, 1:130–132  
   Mallarmé, Stéphane, 2:375–377  
 Pointe shoes, **3:43–44**  
 Pointed toe shoes, 3:169, 173  
 Poiret, Paul, 3:44, **44–48**  
   Albini, Walter, influence on, 1:33  
   art deco, 1:77, 3:348  
   brands and labels, 1:187  
   caricature, 1:229  
   color, 2:359  
   costume design, 1:6, 2:222  
   Doucet, House of, 1:376–377  
   ethnic style, 1:417  
   exoticism, 2:102  
   on fashion, 2:51  
   fashion dolls, 2:38  
   fashion illustrators, use of, 2:49  
   fashion plates, 2:67  
   fashion shows, 2:68  
   Fortuny collections, boutique sales of, 2:113  
   haute couture, 2:188  
   hobble skirts, 3:348  
   international reputation, 2:51  
   Iribe, Paul, illustrations by, 2:250  
   Islamic Orientalism, influence of, 1:338  
   Japanese influence, 2:265, 271  
   jumpers, 2:291  
   kimonos, 2:305  
   Liberty fabrics, 2:354  
   models, use of, 2:58, 59  
   neoclassicism, 2:220, 3:103  
   Orientalism, 1:393, 3:5  
   pajama style, 3:14  
   Paris fashion, 3:19  
   perfume, 3:35–36  
   reform style, 1:382  
   Schiaparelli, Elsa and, 3:145  
   Le syndicat de défense de la grande couture française, 1:216, 279  
   tailed suits, 3:260  
   *la vague* style, 3:348  
   women's trousers, 3:340  
 Poland  
   folk dress, 2:95  
   military uniforms, 3:366  
 Polhemus, Ted, 3:236  
 Police helmets, 2:197  
 Police uniforms, 3:371–372  
*Poliki*, 3:122–123  
 Political prisoners, 3:56  
 Politics and fashion, **3:48–52**  
   First Ladies' gowns, 2:86  
   fur, 2:115, 116  
   future of fashion, 2:117  
   gender, 2:133  
   Hawes, Elizabeth, 2:190  
   homespun, 2:223  
   Islamic dress, 2:252–253

- Latin America, 2:333–334  
 1930s, 3:350  
*sapeurs*, 3:137  
 t-shirts, 3:342–343  
 working-class dress, 3:444
- Polka dress, 1:339
- Pollock, Alice, 1:268
- Polo (brand), 2:275, 340–341, 3:36  
*See also* Lauren, Ralph
- Polo shirts, 3:52, 213
- Polyester, 2:402, 3:52–54
- Polynesia  
 bark cloth, 1:125–126  
 ceremonial costumes, 1:245  
 history, 1:95  
 tattooed man, 1:93  
 tattoos, 3:269
- Polyvinyl chloride. *See* Vinyl as fashion fabric
- Pomona, 3:114
- Ponchos, 1:48
- Ponds, 1:296
- Poodle skirts, 2:76
- Poole, Henry, 3:142
- Pope, Virginia, 2:52
- Popova, Liubov, 1:286, 2:119, 3:126
- Popover dress, 2:398
- Popular culture, 2:24
- Populist model of fashion theory, 2:21
- Portrait buttons, 1:206–207
- Portrait photography  
 Avedon, Richard, 1:105  
 fashion photography, 2:62  
 Hoyningen-Huene, George, 2:228  
 Newton, Helmut, 2:454
- Portugal  
 colonialism, 2:333  
 umbrellas, 3:357
- Pose, 1:343
- Post, Wiley, 3:201–202
- Post-consumer waste, 3:91–92
- Posters, advertising, 2:28
- Postiches*, 2:163
- Postmen, 3:370, 370
- Postmodernism  
 Baudrillard, Jean, 1:133  
 identity, 2:35  
 street style, 3:227
- Poststructuralism, 1:132–134
- Potlatches, 1:243–244
- Potter, Clare, 3:221
- Pouf skirts, 2:327, 327, 3:20
- Pougy, Liane de, 1:355, 355
- Poulaine*. *See* Pointed toe shoes
- Poverty  
 black's association with, 3:454, 455  
 bohemian dress, 1:171
- Powdered wigs, 2:163
- Power  
 codpiece, 1:276  
 suits, 1:379
- Power looms, 3:424–425
- Power sources  
 techno-textiles, 3:274  
 watches, 3:411
- Powers, John Robert, 2:59, 69
- Poynter, Phil, 1:229
- Prada, 3:54–55  
 accessories, 2:127  
 Alaïa, Azzedine, 1:33  
 bowling bag, 2:171  
 handbags, 2:172  
 hip-hop style, 2:217  
 Italian fashion, 2:255, 256  
 precious jewelry, 1:305  
 Scottish textiles  
 sweaters, 3:245  
 window displays, 3:436
- Prada, Miuccia  
 backpack, 2:172  
 Courrèges, André, influence of, 1:310  
 Italian fashion, 2:255  
 1990s fashion, 3:353  
 Orientalism, 3:7  
 Steele, Lawrence, collaboration with, 3:221  
 vintage fashion, 3:400
- Praline, 2:69
- Prayer beads, 1:135
- Pre-Colombian society, 3:283–284
- Pre-consumer waste, 3:91
- Pre-distressed jeans, 1:369
- Pre-industrial era, 3:84–86
- Pre-Raphaelites  
 aesthetic dress, 1:12  
 boots, 1:172  
 European dress, 1:426  
 hairstyles, 2:162  
 wearable art, 3:412
- Preferences, color, 1:282
- Prehistoric dress and customs  
 amulets, 2:443  
 animal skins, 2:343  
 jewelry, 2:277  
 leather tanning, 3:264–265  
 necklaces, 2:441  
 outerwear, 3:7  
 ribbon, 3:105–106  
 scarification, 3:144  
 tattoos, 3:268
- Prehistoric textiles, 3:305–308, 306
- Premet, 1:302
- Preppy style, 2:213–214  
*See also* Ivy League style
- Preservation  
 leather, 2:343–345  
 Southeast Asian weaving, 3:318
- Press weeks, 2:52, 53
- Pressure suits, 3:201–202
- Le Prêt-à-porter Création, 2:188
- Preteens, 2:121–122
- Pretty in Punk* (Leblanc), 3:235
- Price, Anthony, 2:431
- Pricing, 2:51
- The Primary Structures of Fabrics* (Emery), 3:421
- Primrose, George, 1:340
- Princess-cut dresses, 3:448
- Printed patterns, 3:27
- Prints. *See* Decorative prints
- Prison dress, 3:55–57
- Privacy, 3:361
- Private labels, 3:88
- Processes  
 dyeing, 1:385  
 dyeing with natural dyes, 1:389  
 fulling, 2:115  
 leather tanning, 2:344–345  
 pattern-making, 3:27
- Production and manufacturing  
 acrylic and modacrylic, 1:3  
*adire*, 1:9–10  
 African textiles, 3:279–282  
 Armani, Georgia, 1:67  
 armor, 1:70  
 art and fashion, 1:72–74  
 Australian clothing, 1:102–103  
 Baroque clothing, 1:424  
 berets, 1:149, 150  
 bogolan, 1:170  
 boubous, 1:175–176  
 braids, 1:185  
 brassieres, 1:191  
 buttons, 1:207–208  
 Byzantine textiles, 3:286–287  
 calico, 1:215, 215  
 cambric, batiste, and lawn, 1:217  
 camel hair, 1:218  
 capitalism and, 2:386–387  
 cashmere and pashmina, 1:234–236  
 Central American and Mexican textiles, 1:39–40  
 Chinese silk, 3:292–295  
 chintz, 1:267  
 computer-aided design, 2:208  
 cosmetics, 1:298, 299–300  
 costumes, 1:301–302  
 cotton, 1:306–308  
 crinolines, 1:317  
 cuff links and studs, 1:328  
 cutting, 1:330–331  
 democratization of fashion, 2:25  
 embroidery, 1:408  
 equestrian costume, 1:413–414  
 fans, 2:5–6, 7, 8  
 fashion artwork, 2:49–50  
 fashion industry, 2:51  
 felt, 2:76  
 gender and, 2:24  
 girdles, 2:139  
 globalization, 2:143–144  
 Halloween costumes, 2:167  
 hats, 2:411  
 hemlines and textile manufacturers, 2:199  
 high-tech fashion, 2:208–209  
 hook-and-loop closures, 1:270  
 ikat, 2:231, 233  
 Indian textiles, 2:239–240

- Production and manufacturing  
(*continued*)  
indigo, 2:241–242  
Japanese textiles, 3:299–300, 302  
jeans production, Soviet, 1:288  
jockeys' clothing, 3:379  
knitted fabric, 2:311  
labeling laws, 2:319–320  
lace, 2:325, 326  
legal and judicial costume, 2:348  
linen, 2:355  
mechanization, 1:402  
men's hosiery, 2:227  
microfibers, 2:402  
Middle Eastern Islamic dress, 2:403  
Middle Eastern textiles, 3:302–304  
mourning dress, 2:425, 426  
Nazi Germany, 2:8–9  
neckties, 2:447  
needles, 2:448–449  
nonwoven textiles, 2:455–456  
nylon, 2:461, 462  
occupational uniforms, 3:372–373  
paisley shawls, 3:12  
perfume, 3:36–37  
pins, 3:38  
pointe shoes, 3:43  
prehistoric textiles, 3:305–307  
rayon, 3:82–83  
ready-to-wear, 1:401–402, 3:84, 86–89  
ribbons, 3:106–107  
saris, 3:140  
seamstresses, 3:149–151  
sericulture, 3:182–183  
sewing machines, 3:157–158  
shirtwaists, 1:164  
shoemaking, 3:164–169  
shoes, 2:143, 144, 3:172  
silk, 1:82–83, 261  
Southeast Asian textiles, 3:314, 315, 316–318  
Soviet Union clothes production, 1:287  
specialization, 1:400  
sweatshops, 3:247–249  
tartan, 3:268  
tweeds, 3:347–348  
umbrellas and parasols, 3:358–359  
women's hats, 2:183–184  
women's shoes, 3:176–177  
wool, 3:441–442  
workforce, 1:403–404  
working-class clothing, 3:444–445  
worsted yarns, 3:446  
yarns, 3:456  
*See also* Domestic production; Fashion industry; Garment trade and garment workers; Textile workers
- Professional associations, 3:57–58  
Professional garments, 3:373  
Progressivism, 1:359  
Promotion. *See* Marketing  
Propaganda, 2:9–11  
Proportional measure  
cutting, 1:331  
sizing and patterns, 3:28  
Prostitutes, 2:14  
Protective clothing, 2:45, 3:58–60  
armor, 1:71  
earmuffs, 2:193  
helmets, 2:195–198  
military uniforms, 3:368  
Protein fibers, 2:82  
Protest  
fashion as, 3:49, 50, 50  
t-shirts, 3:342–343  
Protestantism, 1:396–397  
Proust, Marcel, 3:60–62, 61  
Proverb cloths, 1:8, 2:297–298, 3:282  
Proximity suits, 3:59  
*Prozodezhda*, 3:126  
Prue, Edwina, 3:23  
Prussia, 3:370  
Psychedelic fashion, 1:77, 3:62–64  
Psychological aspects of dress  
ball dress, 1:112  
casual business dress, 1:237  
color, 1:281–282  
cross-dressing, 1:322–323  
Cunnington, C. Willett and Phillis, 1:328–329  
Flügel, J.C., 2:90–91  
school uniforms, 3:374–378  
shopping, 3:178  
Simmel, Georg, 3:185–186  
studies of fashion, 2:18  
underwear, 3:361  
*The Psychology of Clothes* (Flügel), 2:90–91  
Public laundries, 2:339  
Public relations  
Dior, Christian, 1:366–367  
Paquin, House of, 3:17  
*See also* Advertising; Marketing  
Pucci, Emilio, 3:64–66, 65  
Ferragamo, Salvatore, collaboration with, 2:79  
handbags, 2:172  
Internet site, 2:61  
Italian fashion, 2:254  
jumpsuits, 1:275  
1950s fashion, 3:350  
scarves, 3:143  
Pucci, House of, 2:328  
Pudor, Heinrich, 2:458  
Puech, Jamin, 2:173  
Puff Daddy. *See* Combs, Sean  
Pugin, A.W.N., 2:219  
Pullar, James, 1:384  
*Pulp Fiction* (film), 2:85  
Puma, 3:215  
Punjabi suits. *See* *Salwar-kameez*  
Punk, 3:66–69, 67  
body piercing, 1:168  
costume jewelry, 1:305  
extreme fashion, 1:432  
Gaultier, Jean-Paul, 2:127  
gothic influence, 2:219–220  
music and fashion, 2:433  
1970s fashion, 3:352  
Rhodes, Zandra, 3:104  
safety pins, 1:196  
street style, 3:228  
subcultures, 3:234  
tiaras, 1:326  
Westwood, Vivienne, 3:20, 428–429  
women, 3:235  
Yamamoto, Yohji, 3:454–455  
Purdah, 1:202–203  
Purfling, 2:115  
Purim, 2:167  
Puritans, 1:423–424  
Purity, 3:114, 115–116  
Purple dyes, 1:389, 3:287  
Purses. *See* Handbags and purses  
Purvis, Tom, 2:28  
Putnam, Carolyn, 3:23  
PVC. *See* Vinyl as fashion fabric
- Q**  
Qin dynasty, 3:293  
Qing dynasty, 1:264, 2:108, 3:295  
*Qipao*, 3:71  
ethnic dress, 1:415  
history, 1:83  
revival, 1:266  
Shanghai, 1:265  
western adaptation, 3:6–7  
Quaker dress, 1:381  
Quant, Mary, 3:71–74, 72  
boutiques, 1:180  
cosmetics, 1:299  
fashion models, 2:59  
fashion shows, 2:69  
hairstyles to fit the style of, 2:165  
hemlines, 2:199–200  
London fashion, 2:362  
miniskirts, 1:309, 2:415  
Mod style, 2:430  
models wearing fashions of, 3:73  
1960s fashion, 3:351  
revival of styles of, 3:103  
synthetics, 3:461  
teenage fashion, 3:276  
tights, 3:224  
vinyl as fashion fabric, 3:400  
Youthquake fashion, 3:459–462, 461  
Quantas Airways, 3:65  
*The Queen*, 2:55  
Quiksilver, 1:103  
Quillwork embroidery, 1:409  
Quilting, 3:74–75, 75  
*Quinceañeras*, 1:349, 2:336  
Quorum, 1:268, 269  
Qur'an  
*hijab*, 2:210  
Islamic dress, 2:251  
*jilbab*, 2:289  
women's clothing, 1:370



## R

- Rabanne, Paco, **3:77–79**, 78  
 Courrèges, André, influence of, 1:309, 310  
 future of fashion, 2:117  
 metal-linked garments, 2:207  
 1960s fashion, 3:351  
 perfume, 3:36  
 space age style, 3:200  
 vinyl as fashion fabric, 3:400
- Race/ethnicity  
 Barbie, 1:122  
 in De La Renta's designs, 1:350  
 debutantes, 1:349  
 indigenous textiles, 3:99  
 Jewish dress restrictions, 2:286–287  
 reenactors, 3:94  
 subcultures, 3:235–236  
 Zoot Suit Riot, 3:467
- Racinet, Auguste, 2:17–18
- Racism  
 Civil War reenactors, 3:94  
 cosmetics industry, 1:297  
 Rags and recycling, 3:91–92  
 Railway travel, 3:333  
 Raincoats, 1:200–202, 273, **3:79**  
 Rainey, Michael, 3:263  
 Rainwear, **3:79–81**  
 Driza-Bone, 3:3  
 oilskins, 3:2–3  
 rubber, use of, 3:121  
 Rajasthan turbans, 3:344  
 Ramie, 2:356, **3:81**  
 The Ramones, 3:67  
 Rand, Sallie, 2:273  
 Rank and uniforms, 3:363, 365, 369  
 Rap. *See* Hip-hop  
*Rashpatmyi*, 3:123  
 Rastafarian dress, 1:30, 150, 2:432, 3:234, 235  
 Rates of fashion change, 2:343  
 Ratia, Armi and Viljo, 2:383  
 Ratia, Risomatti, 2:385  
 Ratiné yarns, 3:458  
 Rational dress, 1:382, 2:220, 447, 3:233  
 Rationing, 2:11  
 Rauschenberg, Robert, 1:340, 3:435
- Rave  
 body piercing, 1:168  
 dance and fashion, 1:336  
 music and fashion, 2:431–432
- Rawlinson, Thomas, 2:97–98, 301
- Ray, Man, 2:64, 379, 3:146, 147  
 Ray-Ban sunglasses, 3:240, 241  
 Raymond, 2:161  
 Raynor, Dorothy, 3:23  
 Rayon, 2:356, **3:81–84**  
 Reactive dyes, 1:388  
 Read, Benjamin, 2:66  
 Ready-to-wear, **3:84–90**  
 Adrian, 1:11  
 advertising, 2:28  
 Alaïa, Azzedine, 1:32  
 Armani, Giorgio, 1:66–68  
 art and fashion, 1:73–74  
 art nouveau, 1:76  
 Australian fashion, 1:102  
 Brooks Brothers, 1:197–198  
 Capucci's opposition to, 1:222  
 Cardin, Pierre, 1:224  
 Cashin, Bonnie, 1:232  
 Chanel, Gabrielle (Coco), 1:249  
 Clark, Ossie, 1:269  
 cocktail dresses, 1:275  
 crochet, 1:319  
 democratization of fashion, 2:25  
 Dolce & Gabbana, 1:371  
 embroidery of Lesage, 2:351  
 fashion editors, 2:40  
 fashion models, 2:59  
 fashion shows, 2:69–70  
 Fath, Jacques, 2:73  
 Fendi, 2:77  
 folklore look, 2:103  
 Fontana sisters, 2:104–105  
 Galanos, James, 2:123, 124  
 Givenchy, Hubert de, 2:142  
 Gucci, 2:156  
 hats, 2:183  
 haute couture and, 2:189  
 India, 2:240  
 Lagerfeld, Karl, 2:328  
 maternity dress, 2:395  
 mechanization of production, 1:402  
 mourning dress, 2:426  
 nightwear, 2:455  
 1960s fashion, 3:351  
 origins of, 1:401–402  
 press coverage, 2:53–54  
 Rabanne, Paco, 3:78  
 Saint Laurent, Yves, 3:20, 131–132  
 shoes, 3:166  
 space age style, 3:200  
 Spanish fashion, 3:206  
 sportswear, 3:221  
 Treacy, Philip, 3:335  
 Viktor & Rolf, 3:398  
 Vionnet, Madeleine, 3:404  
 Vuitton, Louis, 3:408  
 Youthquake fashion, 3:459–462
- Reagan, Nancy  
 De La Renta, Oscar, fashions of, 1:350–351  
 Galanos, James, fashions of, 2:124
- Realism, 2:63–64  
 Réard, Louis, 3:350  
 Rebellion, 1:172  
 Reboux, Caroline, 2:412  
 Reconstructive surgery, 3:40  
 Recycled textiles, **3:90–92**, 92  
 Margiela, Martin, 2:382  
 polyester, 3:53  
 textiles, 3:90–92, 92  
 Xuly, Bët, 3:451  
*See also* Secondhand clothes
- Red  
 dyes, 1:389  
 Islamic dress, 2:406  
 royal and aristocratic dress, 3:119  
 textiles, 3:281–282  
 Redditch, England, 2:448–449  
 Redfern, John  
 as artistic bohemian, 1:73  
 embroidery of Michonet, 2:350  
 equestrian costumes, 1:413–414  
 women's tailored suits, 3:259, 348  
 Reebok, 2:144, 3:196, 215  
 Reed, Austin, 3:237–238  
 Reenactors, 2:132, **3:92–94**, 93  
 Rees, Dai, 2:399  
 Rees, Serena, 2:357  
 Reform, garment industry, 2:145  
 Refrigerated clothing, 3:273  
 Refugees, 3:317  
 Regency dandyism, 1:344  
 Reger, Janet, 2:357  
 Regional Spanish dress, 3:205–206
- Regulations  
 body piercing, 1:169  
 cosmetics, 1:298  
 haute couture, 2:187  
*hijab*, 1:247  
 Jewish dress, 2:287–288  
 school uniforms, 3:374–378  
 sweatshops, 2:51, 3:248  
 tartan, 3:267  
*See also* Sumptuary laws
- Rehnquist, William, 2:348, 3:111
- Reid, Mrs. Ogden, 3:57  
 Reindeer skins, 2:98  
 Réjane, 3:44  
 Religion and dress, **3:94–100**  
 beads, 1:134, 134–135, 135  
 beards and mustaches, 1:136  
 brooches, 1:197  
 ecclesiastical dress, 1:395–400  
 embroidery, 1:407–408  
 gender and dress codes, 2:133  
*hijab*, 2:209–212  
*kaffiyeh*, 2:293–294  
 occult dress, 3:1–2  
 pendants, 2:443  
 religious profiling, 2:253  
 robes, 3:111–112  
 shrouds, 3:181  
 sumptuary laws, 3:239  
*See also* Specific religions
- Religiosity, 3:98  
 Religious dramas, 3:322  
 Remfy, David, 2:49  
 Remote Control Dress, 1:248, 2:209  
 Renaissance period  
 armor, 1:70  
 ballet costumes, 1:114  
 codpiece, 1:276  
 hairstyles, 2:162  
 Italy, 1:422–423  
 jewelry, 2:281  
 revivals, 1:304–305

- Renaissance period (*continued*)  
 rings, 3:109  
 theatrical costumes, 3:322  
 women's hats, 2:181–182
- Renal, Georgette, 1:216
- Rendez-vous* (Barbier), 1:123
- Repository of the Arts, Literature, Commerce, Fashion and Politics*, 2:55
- Republican Guard, 3:363
- Research  
 Barthes, Roland, 1:128  
 fragrances, 3:36–37  
 historical studies of fashion, 2:16–20
- Reservoir Dogs* (film), 2:85
- Resiliency, wool, 3:442–443
- Resilient Construction, 2:447
- Resist dyeing, **1:387**  
*adire*, 1:8–10  
 batik, 1:129  
 indigo, 2:242  
 West Africa, 3:281
- Resor, Helen, 3:57
- Restraining forces, 2:72
- Retail Brand Alliance, 1:199
- Retailing, **3:100–103**  
 canes and walking sticks, 1:220  
 changes in, 1:404  
 department stores, 1:361–363  
 education in, 2:41  
 equestrian costume, 1:413–414  
 history, 1:402–403  
 Lauren, Ralph, 2:341  
 legal and judicial costume, 2:348  
 London fashion, 2:362  
 manufacturer/retailer tension, 2:50–51  
 Marks & Spencer, 2:385–386  
 merchandising, 2:57  
 mergers, 2:52  
 Quant, Mary, 2:258–259  
 ready-to-wear, 3:87–88  
 retail parks, 3:179–180  
 shop types, 3:179–180  
 twentieth century, 2:25  
 unisex clothing, 3:383  
 vintage fashion, 3:399  
*See also* Consumers; Shopping
- Reticella*, 2:325
- Retro-futurism, 2:430–431
- Retro styles, **3:103–104**  
 eyewear, 1:434  
 Kamali, Norma, 2:296  
 Saint Laurent, Yves, 3:131  
 social aspects, 2:220–221  
 swimwear, 3:255  
*See also* Revivals, historic
- Retting, 2:200
- Reutlinger, Maison, 2:62
- Reversals, 2:382
- Reverse appliqué, 1:64
- Revivals, historic, **2:219–221**  
 A-Line, 1:36  
 by aesthetic movement, 1:12  
*ao dai* style, 1:62  
 art deco, 1:77–78  
 art nouveau, 1:77  
 classical style, 1:422–423  
 crinolines, 1:318  
 cultural revival movements, 1:279  
 Dior, Christian, 1:367–368, 3:37  
 earring styles, 1:392–394  
 empire-line dresses, 1:264  
 Empire style, 1:411, 427, 3:272  
 folk costume, 1:339  
 French fashion, 3:20  
 Gothic, 1:396, 397  
 Great Depression, 2:272  
 handmade lace, 2:326  
 handweaving, 3:413  
 hippie style, 2:219  
 historical styles during the Great Depression, 3:6  
 knotting, 2:312  
 Liberty & Co., 2:354  
 miniskirts, 2:416  
 mod, 1:310–311  
 muff, 2:428  
 1960s, 3:152  
 petticoats, 3:38  
 Pucci, Emilio, 3:65–66  
*qipao*, 1:266  
 quilting, 3:75  
 retro style, 3:103–104  
 Roman diadems, 1:324–325  
 urban department stores, 1:361  
 Western fashion in Russia, 1:286  
 women's shoes, 3:177  
 zoot suits, 3:468
- Revlon Inc., 2:437, 439
- Revson, Charles, 2:437–438
- Reworking of collection pieces, 2:382
- Reynaud, Alain, 2:105
- Reynolds, Joshua, 1:226
- Reza Shah, 2:408
- Rhetoric, fashion, 1:128
- Rhinoplasty, 2:234
- Rhodes, Zandra, **3:104–105**, 105  
 embroidery, 1:409  
 folklore look, 2:103  
 London fashion, 2:362  
 Museum of Fashion and Textiles, 2:60  
 Youthquake fashion, 3:462
- Rhodoïd, 3:77
- Rib weave, 3:417
- Ribbons, **3:105–108**, 107  
 gowns, 2:258  
 hair, 2:157  
 trimmings, 3:338
- Ribeiro, Aileen, 2:368
- Ribeiro, Clements, 1:269, 3:245
- Ricci, Nina  
 embroidery, 1:409  
 milliners, 2:412  
 perfume, 3:36
- Rabanne, Paco and, 3:77
- Richardson, Bob, 2:64, 203
- Richmond, John, 2:432
- Riding apparel. *See* Equestrian costumes
- Right Bank, 1:357
- Riley, William J., 3:196
- Rimala, Annika, 2:384
- Ring spinning, 3:456
- Ringgold, Faith, 3:75
- Rings, **3:108–110**, 427
- Rip Curl, 1:103
- Rites of passage  
 capping ceremonies, 1:260  
 ceremonial costumes, 1:241–243  
 debutante balls, 1:348–350  
 masks, 2:390–392  
 penis sheaths, 3:29  
 veils, 3:392  
*See also* Ceremonial and festival costumes; Rituals
- Ritts, Herb, 2:65, 226
- Rituals  
 Modern Primitives, 2:421  
 shrouds, 3:181  
*See also* Ceremonial and festival costumes; Rites of passage
- Rivets, 1:360, 2:351–352
- Rizzo, Pippo, 2:119
- Robe de chambre*. *See* Tea gowns
- Robe de style*, 2:332, 3:107, 349
- Roberts, Patricia, 2:310, 3:245
- Robes, 2:346–348, **3:110–114**  
*Les Robes de Paul Poiret* (album), 3:45
- Robespierre, Maximilien, 2:445
- Robinson, Helen, 2:432
- Robinson, J. Mack, 3:130–131
- Robinson, Patrick, 1:407
- Robinstein, Helena, 3:57
- Rocawear, 2:275
- Rochas, Marcel  
 New Look, origins of the, 2:452  
 Orientalism, 3:6
- Rochford, Brian, 1:103
- Rock and roll, 1:336
- Rococo period, 1:421  
 European and American dress, 1:424–425  
 hair adornment, 2:159  
 jewelry, 1:303
- Rodchenko, Alexander, 1:286, 3:126, 413
- Roddick, Anita, 1:299
- Roderick Random* (Smollett), 3:118
- Rodgers, Shannon  
 fashion of, 3:86  
 ready-to-wear, 3:87–88
- Rodhe, Lennart, 1:398
- Rodier, Paul, 1:216
- Rodriguez, Narciso  
 on Halston, 2:168–169  
 Klein, Calvin and, 2:307  
 Latin American fashion, 2:335
- Rogers, Millicent Huddleston, 2:259
- Roland Barthes par Roland Barthes* (Barthes), 1:127

- Rollbag, 2:78  
 Roma and gypsies, **3:114–116**  
 Roman Catholic Church  
   change in dress, 3:99  
   ecclesiastical dress, 1:396, 397–398  
 Romanian folk dress, 2:95  
*Romantic and Glamorous: Hollywood Style*  
   (exhibit), 2:221  
 Romanticism  
   ballet costumes, 1:115  
   dandyism and, 1:341  
   dress for success, 1:379  
   evening dress, 1:428  
   fancy dress, 2:3  
   Gigli, Romeo, 2:137–138  
   Givenchy, Hubert de, 2:141  
   Hartnell, Norman, 2:175–176  
   histories of fashion, 2:16–17  
   Lanvin, Jeanne, 2:332  
   women's hats, 2:183  
 Rome, ancient  
   ballet costumes, influence on, 1:114  
   black and mourning, 3:119  
   cross-dressing, 1:321  
   crowns, 1:324  
   dress in, 1:57–58  
   earrings, 1:391, 392  
   hairstyles, 2:162  
   jewelry, 2:279–280  
   men's headwear, 2:177  
   sandals, 3:136  
   shoemaking, 3:164  
   South Asian dress, influence on, 1:87  
   sport shoes, 3:213  
   togas, 3:329, 329–330  
 Romijn-Stamos, Rebecca, 2:71  
 Rommel, Jacques and France, 2:38  
 Rompers, 1:258–259  
*A Room of One's Own* (Woolf), 1:344  
 Roosevelt, Eleanor, 3:57  
 Rootstein, Adel, 2:379  
 Rosaries, 1:134  
 Rose motif, 3:404  
 Rose-Pulham, Peter, 2:64  
 Rosenbaum, Edith L., 3:439  
 Rossellini, Isabella, 1:372  
 Rosso, Renzo, 2:255  
 Rotary silk-screening, 1:387  
 Roth, Christian Francis  
   appliqué, use of, 1:64  
   grunge, 2:154  
 Rotor spinning, 3:212, 456  
 Rouff, Maggy  
   art nouveau, 1:76  
   Rabanne, Paco and, 3:77  
 Roundheads, 1:423  
 Rounthwaite, Graham, 2:49  
 Rousseau, Jean-Jacques, 3:170  
 Rowan Yarns, 2:310  
 Rowlandson, Thomas, 1:228  
 Royal and aristocratic dress, *3:116, 116–120, 117, 118*  
   caricature, 1:225–227  
   ceremonial costumes, 1:245  
   crowns and tiaras, 1:324–327  
   gender and, 2:131–132  
   headdresses, 2:193–194  
   mourning dress, 2:425–426  
   perfume, 3:34–35  
   Russia, 3:122–125  
   suits, 3:237  
   *See also* Court dress  
 Royal Ascot, 2:111, 414  
 Royal College of Art, 1:268, 3:459  
 Royal footmen, *3:371*  
 Royal Ontario Museum, 2:61  
*Rubakhi*, 3:121  
 Rubber, 1:405, **3:120–121**, 194–195  
 Rubinstein, Helena, 1:297, 2:358, 3:47  
 Ruffs, 1:431  
 Rugby shirts, 3:213, 218, 220  
 Rugby uniforms, 3:380–381  
 Rugs, 2:174  
 Rumba dress, 1:339  
 Runway modeling, 2:58, 59, 69  
 Rural dress  
   Bangladesh, 3:308  
   homespun fabrics, 2:223  
   India, 3:310  
   Indian dress, 2:235  
   Middle Eastern Islamic dress, 2:408–409  
   North Africa, 1:17  
   *See also* Folk dress  
 Russell, Kristian, 2:49  
 Russian dress, **3:121–127, 122**  
   ballet costumes, 1:114–116, 340  
   Chanel, Gabrielle (Coco), influence on, 1:250  
   Communist dress, 1:286–288  
   folk dress, 2:93, 94–95  
   GUM department store, *1:361*  
   pointe shoes, 3:43  
 Russian Fringe Tiara, 1:326  
 Russian Orthodox Church, 2:195  
 Rykiel, Sonia, **3:127–128**  
   ballerina fashion shoes, 3:43  
   ethnic style, 1:417  
   handbags, 2:173  
   sweaters, 3:245
- S**  
 Saami, 2:98, 247  
*Sabrina* (film), 2:83  
 Sack dresses. *See* Chemise dresses  
 Sack gowns, 2:395  
 Sacred dress, 3:95–96  
 Sadikin, Ali, 1:130  
 Sadoomasochism  
   body piercing, 1:168  
   fetish fashion, 2:80–81  
 Safavid dress, 2:407  
 Safavid textiles, 3:303  
 Safety pins, 1:196, **3:129**  
   *See also* Pins  
 Safety razors, 1:119, 136, 2:160  
 Safety skirts, 1:412  
 Sage, Russell, 1:202, 3:399  
 Sailors  
   blazers, 1:160  
   McNamara's Lace, 2:312  
   oilskins, 3:2  
   t-shirts, 3:341  
   tattoos, 3:269  
   *See also* Military uniforms; Nautical style  
 Saint Angelo, Vittorio, 3:468  
 Saint-Cyr, Claude, 2:413  
 Saint Cyr, Lili, 3:231  
 Saint Edward's Crown, 1:327  
 Saint-Étienne, France, 3:107  
 Saint Laurent, Yves, 1:352, **3:129–133, 130**  
   accessories, 2:127  
   advertising, 2:29  
   Alaïa, Azzedine, designs by, 1:32  
   art deco revival, 1:78  
   Blass, Bill, copying by, 3:103–104  
   caftan style, 1:212  
   costume design, 2:83  
   on Courrèges, André, 3:200  
   Dior, House of, 1:368  
   embroidery, 1:409, 2:350, 351  
   ethnic style, 1:417  
   eyewear, 1:434  
   fashion museum, 2:60  
   folklore look, 2:103, *103*  
   folkloric theme, 1:339  
   haute couture, 2:188  
   homosexuality, 2:32  
   on jeans, 2:276  
   masculine look for women, 3:383  
   military style, 2:410  
   New Look, dismissal of the, 2:451  
   1950s fashion, 3:350  
   1960s fashion, 3:351  
   1970s fashion, 3:352  
   nonsuit formal male attire, 2:450  
   occupational uniforms, 3:372  
   Paris fashion, 2:13, 3:20  
   perfume, 3:36  
   Pop Art collection, 1:72  
   psychedelic fashion, 3:63  
   Trapeze Line, 1:35–36  
   trench coats, 3:80  
   tuxedos, 3:345  
   on underwear, 2:141  
   Windsor, Duchess of, 3:438  
   *Women's Wear Daily* review, 3:440  
   youthful fashion, 3:128  
 Saints, 1:321, 3:164  
 Salens, Ann, 1:142  
 Saline implants, 2:234  
 Salons  
   cosmetics, 1:296–297  
   hairdressers, 2:160–161, 164  
*Sakwar-kameez*, 1:418, 2:240, **3:133–134, 140, 310**  
 Samba dress, 1:339



- Samhain, 2:166  
 Samoa, 3:269  
 Samson silks, 3:287  
 Samurai, 2:268–270, 269, 303, 304  
 San Francisco, CA  
   hippie style, 2:218  
   teenage fashion, 3:276  
 San Marino Woman's Club, 1:349  
 Sand shoes, 3:194  
 Sandals, **3:135–137**, 168, 169, 173  
 Sande masks, 2:391  
 Sanders, Altina, 1:433  
 Sanders, Jill, 3:353  
 Sanderson, Elizabeth C., 3:154  
 Sandoz, A., 2:67  
 Sanitary belts, 1:146  
 Sapara, Oguntola, 1:31  
*Sapeurs*, **3:137**  
*Sarafan*, 3:124, 125  
 Sardanapulus, 1:321  
 Saris, **3:138–140**, 139  
   Bangladesh, 1:91  
   ethnic dress, 1:415  
   India, 2:235, 236  
   South Asian dress, 1:91, 92  
   textiles, 3:310  
 Sarongs, **3:141–142**  
   batik, 1:129–130  
   India, 1:88  
   Malaysia, 1:94  
   Orientalism, 3:6  
   Southeast Asia, 1:98–99, 3:313  
   Sri Lanka, 1:89  
 Sasanid dress, 2:249  
*Sashiko*, 3:302  
 Sass and Bide, 1:103  
 Sassoon, Belville, 1:363  
 Sassoon, Vidal, 2:159–160, 161, 165, 3:351  
 Satanists. *See* Occult dress  
 Satellite television, 2:70  
 Satin weave, **3:417–419**, 418  
*Saturday Night Fever* (film), 1:336  
 Savile Row, 2:361, **3:142–143**, 263  
 Savoy ballroom, 1:335  
 Saxony tweeds, 3:346  
 Scaasi, Arnold, 2:86  
 Scales, cutting, 1:331  
 Scandinavia  
   fashion education, 2:42  
   folk dress, 2:98  
 Scanning, body, 1:331  
 Scarabs, 3:108–109  
 Scarf, **3:143–144**  
 Scarification, 1:242, **3:144–145**  
 Scarves, 2:113, 202, 445–446, **3:143–144**  
*Scenario* (modern dance), 1:284–285  
 Schaefer, Rudolph, 1:333  
*Scheherazade* (ballet), 3:45  
 Scherrer, Jean-Louis, fashion of, 3:5  
 Schiaparelli, Elsa, **3:145–148**, 146  
   appliqué, use of, 1:64  
   Cardin, Pierre and, 1:223  
   Chanel, as competitor to, 3:19  
   cocktail dresses, 1:274  
   color and brand identification, 1:283  
   costume design, 2:82  
   costume jewelry, 1:303  
   Dalí, Salvador, work by, 1:72  
   embroidery of Michonet, 2:350  
   eyewear, 1:434  
   fashion illustrators, 2:49  
   fashion shows, 2:69  
   film and fashion, 2:85  
   folklore look, 2:102  
   hairnets, 2:192  
   handbags, 2:172  
   hats, 2:412  
   on Hollywood costumes, 2:222  
   hot pink, 2:315  
   Italian fashion, 2:254  
   1930s fashion, 3:350  
   perfume, 3:36  
   sweaters, 3:245, 245  
   swimwear, 3:252  
   tailored suits, 3:261  
   trends, 2:184  
   Vreeland, Diana, patronage of, 3:406  
   Windsor, Duchess of, 3:438  
   zippers, 2:202, 207, 3:465  
 Schiffer, Claudia, 3:243, 244, 395  
 Schleger, Hans, 2:28  
 Schnurer, Carolyn, 3:254  
 Schoerner, Norbert, 2:400  
 Scholte, Frederick, 3:436  
 School uniforms, **3:373–378**, 376, 377  
 Schuberth, Emilio, 2:254, 3:350  
 Schultz, Augustus, 2:344  
 Scianna, Ferdinando, 1:372  
 Scotch tweeds, 3:346  
 Scott, Sir Walter, 3:268  
 Scott, Venetia, 2:203  
 Scott Paper Company, 3:16  
 Scottish dress, 3:148, **148–149**  
   bluebonnets, 1:150  
   embroidery, 1:408  
   folk dress, 2:97–98  
   kilts, 2:301–302  
   paisley, 3:12–13  
   plaid, 3:39  
   shawls, 3:161  
   tartan, 3:267–268  
   tweeds, 3:346–347  
 Screen printing, 1:387, 2:114, 3:342  
 Scroll and Collet Spike Tiara, 1:325  
 Scrunchies, 2:157  
 Scupp, Gerald, 3:156  
 Scurto, Ignazio, 2:118  
 Scuttlers, 3:275  
 Sealskins, 2:245, 247  
 Seam-powered sewing machines, 3:86  
 Seamless garments, 2:37, 209  
 Seams, sealed, 3:79  
 Seamstresses, **3:149–151**  
   *See also* Dressmaking; Tailoring and tailors  
 Sears, Roebuck and Company, 1:403, 3:87, 341  
 Seat belts, 1:146  
 Seattle, WA, 2:153–154  
 Sebastian, John, 3:327  
 Second skin concept, 2:118  
 Secondary sex characteristics, 2:129  
 Secondhand clothes, **3:151–155**, 152, 154  
   economics and fashion, 1:404  
   ethnic dress and, 1:416  
   globalization, 2:145  
   grunge, 2:154  
   hippie style, 2:218  
   Kenya, 3:87  
   pre-industrial era, 3:85  
   shopping, 3:180  
   working-class dress, 3:445  
   *See also* Recycled textiles; Vintage fashion  
 Secular dress, 3:95–100  
 Seduction, 2:14, 343  
 Seebeck effect, 3:274  
 Seeberger brothers, 2:62, 67  
 Seersucker, 1:316, 3:216  
 Selena, 2:335  
 Self  
   Afrocentric fashion and, 1:28  
   consumption, 3:178  
   dress for success, 1:379  
   gender and dress, 2:132  
   identity and, 2:34–35  
   school uniforms, 3:374–375  
   street style, 3:226–228  
 Self-shaving, 1:119, 136  
 Selfridge, Gordon, 3:434  
 Semiformal jackets, 3:345  
 Semipermanent tattoos, 3:270  
 Semon, Waldo L., 3:400  
 Semsch, Sitka, 2:335  
 Senegal  
   *betbio*, 3:11–12  
   boubous, 1:175–177  
   Sy, Oumou, 3:255–257  
 Senghor, Léopold Sédar, 1:28  
 Sensors, embedded, 3:273  
 Separate spheres theory, 1:322, 2:24  
 Separates  
   fashion change, 2:22  
   Karan, Donna, 2:298–299  
   maternity dress, 2:395  
   McCardell, Claire, 2:397  
 Separation  
   *bijab*, 2:210  
   veils, 3:392–393  
 September 11 attacks, 2:253  
 Sequins. *See* Spangles  
 Sericulture, 3:182–183, 290, 292–293  
 Set design, 1:137–138  
*Setts*, 3:267–268  
*Seventeen* (magazine), 3:275  
 Seventeenth century  
   actors and actresses, 1:6

- ballet costumes, 1:114–115  
 breeches, 1:194  
 cosmetics, 1:295  
 court dress, 1:312  
 doublets, 1:376  
 earrings, 1:392  
 fans, 2:5–6  
 gender and dress, 2:131  
 gloves, 2:146  
 hairstyles, 2:163  
 lace, 2:325–326  
 legal and judicial costume, 2:346–347  
 maternity dress, 2:395  
 men's hats, 2:178–179  
 Middle Eastern Islamic dress, 2:407–408  
 ribbons, 3:106  
 tailoring, 3:262  
 waistcoats, 3:409  
 wigs, 3:430  
 women's shoes, 3:174  
 Seventh Avenue, **3:155–157**  
 Sevigny, Chloë, 3:399  
 Sewing  
   domestic production, 1:373  
   Inuit and arctic clothing, 2:245  
   Inuit and arctic footwear, 2:246–248  
   patterns, 1:358–359  
   Spain, 3:205  
   working-class dress, 3:445  
 Sewing machines, **3:157–159**  
   industrial revolution, 1:402  
   ready-to-wear production, 3:86–87  
   seamstresses, 3:150  
   shoemaking, 3:167  
   sneakers, 3:195  
   steam-powered, 3:86  
 “Sex and the City” (television show)  
   high heels, 2:205  
   Manolo, Blahnik, shoes of, 1:240  
   vintage fashion, 3:399  
 Sex Pistols, 3:67–68  
 Sexuality  
   advertising, 2:29  
   cache-sexe, 1:211–212  
   Cunnington, C. Willett and Phillis, 1:328–329  
   dress for success, 1:378  
   fetish fashion, 2:80–81  
   future of fashion, 2:117  
   historical studies of fashion, 2:18  
   lingerie, 2:356–357  
   *pagnes*, 3:11–12  
   religion and dress, 3:95–96, 98  
   tango, 1:334–335  
   women's dress, 2:14  
 Seydou, Chris, 1:170, **3:159–160**  
 Seymour, Jane, 3:120  
 Seymour, Lyn, 3:231  
 Seymour, Stephanie, 3:243  
 Sha'atnez, 2:284  
 Shadows  
   Beaton, Cecil, 1:138  
   Bourdin, Guy, 1:178  
   Shaft looms, 2:362–363, 2:363  
   Shakers, 3:99  
   Shakespearean plays, 3:322  
   Shaman footwear, 2:247  
   Shang dynasty, 3:293  
   Shaped-resist dyeing, 3:301  
   Shapiro, Joseph M., 3:26  
   Sha'rawi, Huda, 2:211–212  
   Sharov, Andrei, 3:127  
   Shaver, Dorothy, 3:57  
   Shaving, 1:119, 136  
   Shawls, **3:160–3:162**  
     cashmere and pashmina, 1:233, 234–235, 236  
     Coptic, 3:299  
     Middle East, 3:303  
     nineteenth century, 3:9  
     North African dress, 1:18  
     Orientalism, 3:5  
     paisley, 3:12  
     Russian, 3:125  
   Sheard, Stephen, 2:310  
   Shearer, Norma, 1:10, 11  
   Shearing, 3:441  
   Sheerness, 3:45  
   Sheppard, Eugenia, 2:53, 54  
   Sheridan, Mrs. Richard, 1:6  
   Shetland islanders, 2:309  
   *Shibori*, 3:327  
   Shields, Brooke, 2:64, 274, 275, 306  
   Shilling, David, 2:414  
   Shirts, **3:162**  
     cuff links and studs, 1:327–328  
     dress, 1:382–383  
     Garibaldi, 1:163  
     Hawaiian, 2:189–190  
     Pendleton, 2:154  
     polo, 3:52, 213  
     rugby, 3:213, 218, 220  
     sport, 3:212–213  
     sweatshirts, 3:245–247  
     t-shirts, 2:84, 3:341–343  
     wing collared, 1:383  
   Shirtwaist blouses, 3:162  
   Shirtwaists, 1:163–164, **3:162–164**, 163  
   *Shishbadur*, 1:409  
   Shocking pink, 3:146  
   Shoelaces, 3:195  
   Shoemaking, **3:164–169**, 165  
   Shoes, **3:168–178**  
     bicycling, 1:154, 155  
     Blahnik, Manolo, 1:157–159  
     dance, 3:323  
     Ferragamo, Salvatore, 2:78–80  
     fetish fashion, 2:81  
     footbinding, 2:107, 107–109  
     Ford, Tom, 2:109  
     golf, 2:149  
     health aspects, 2:44  
     high heels, 2:204, 204–205, 205  
     hip-hop style, 2:216–217  
     pointe shoes, 3:43  
     production and manufacturing, 2:143, 144  
     tap-dance, 1:340  
 Shopping, **3:178–180**  
   boutiques, 1:180–181  
   department stores, 1:362  
   globalization of fashion, 2:143  
   *See also* Consumers; Retailing  
 Shortages, 2:11  
 Shortie pajamas, 3:13  
 Shorts  
   Bermuda shorts, 2:150  
   tennis, 3:278–279  
 Shôsôin costumes, 2:266–267  
 Shoulder pads, 3:349–350  
 Shoulder sticks, 3:166  
 Showa period, 2:261–262, 305  
 Showmanship  
   Galliano, John, 2:70, 125  
   McQueen, Alexander, 2:399–400  
   Moschino, Franco, 2:424  
   Shrimpton, Jean, 2:59, 64, 3:199, 242, 355  
 Shrinkage control, 2:114–115, 3:32  
 Shrouds, **3:180–182**, 181  
 Shuttle looms, 3:414, 424  
 Shuttle suits, 3:202  
 Shuttleless weaving, 3:414–415, 424–425  
 Si Hoang, 1:62  
 Siberia, 2:243–244  
 Sidesaddle riding, 1:412  
 SIDS (Sudden Infant Death Syndrome), 3:273  
 Siedle, Caroline, 1:300  
 Siégel and Stockman, 2:377, 379  
 Sierra Leone  
   masks, 2:391  
   rites of passage costumes, 1:242  
 Sign structures, 1:132–134  
 Signet rings, 3:108, 109–110  
 Signification and social meaning, 1:132–134, *133tab1*  
 Signifiers, gay identity, 2:31–32  
 Sikh turbans, 3:344  
 Silhouettes, 2:422, 3:272  
 Silicone breast implants, 2:234, 234  
 Silk, **3:182–185**, 183, 184  
   Byzantine Empire, 3:286–287  
   Central Asia, 3:289–290  
   Central Asian weaving techniques, 3:290–291  
   Chinese, 3:291–295  
   Greece, ancient, 1:55–56  
   Hawaiian shirts, 2:189  
   labeling laws, 3:319  
   linen, as substitute for, 2:356  
   Middle East, 3:302–303  
   production, 1:261  
   rayon as alternative to, 3:82, 83  
   satin weaving, 3:418  
   shoes, 3:174  
   Southeast Asia, 3:314  
   *suzan dozi* embroidery, 3:291  
   Tang dynasty, 1:262

- Silk (*continued*)  
 velvet, 3:394  
 Silk Road, 3:182, 288–289  
 Silk screen printing, 1:387, 2:114, 3:342  
 Silks, jockeys', 1:413, 3:379  
 Silks, Philip, 1:232  
 Simmel, Georg, 1:75, 2:18, **3:185–186**, 198, 336  
 Simmons, Russell, 2:217, 3:276  
 Simone, Nina, 1:25, 27  
 Simons, Raf, 1:145, 2:430  
 Simplicity  
 Baudelaire, Charles, 1:131  
 Brummell, George, 1:199–200  
 ecclesiastical dress, 1:398  
 Halston, 2:168–169  
 Penn's fashion photography, 3:30–31  
 Quaker dress, 1:381  
 Simplicity Pattern Company, 3:26  
 Simpson, Wallis. *See* Windsor, Duke and Dutchess of  
 Simpson Piccadilly, 1:362  
 Sims, David, 2:203  
 Sims, Molly, 2:71  
 Simultaneity, 1:351–352  
*Sindur*, 2:238  
 Singer, Isaac, 3:86, 157, 158, 167, 195  
 Single spun yarns, 3:458  
 Sinhalese dress, 1:89  
 Sirikit, Queen, 3:318  
*Six* (magazine), 1:284  
 Sixteenth century  
 breeches, 1:193–194  
 doublets, 1:375–376  
 earrings, 1:391–392  
 fans, 2:5  
 hair styles, 2:162  
 lace, 2:325  
 legal and judicial costume, 2:346  
 maternity dress, 2:394  
 Middle Eastern Islamic dress, 2:406–407  
 tailoring, 3:262  
 trousers, 3:340  
 Size  
 Indian apparel, 2:240  
 patterns, 3:28  
 retail stores, 3:100–101  
 standardization, 3:86  
 tailoring, 3:263  
 women's average, 2:129  
*See also* Measurement  
 Skateboarders, 3:227, 246  
 Skating dress, **3:186–188**, 187  
 Skeleton suits, 1:257  
 Ski clothing, **3:188–190**, 189  
 Ski helmets, 2:198  
 Skinheads, 3:234  
 Skinning (scarification), 3:144, 145  
 Skins  
 Egypt, ancient, 1:54  
 history of use, 2:343  
 Inuit and arctic clothing, 2:242–245  
 Inuit and arctic footwear, 2:246–248  
 North American indigenous peoples, 1:44  
 tanning, 3:264–265  
*See also* Leather and suede  
 Skirt-kilts, 2:302  
 Skirt supports, **3:190–191**  
 Skirts, **3:190**  
 dirndl, 2:99  
 Egypt, ancient, 1:54  
 equestrian costume, 1:412  
 extreme fashion, 1:431  
 hobble skirts, 3:348  
 hoopskirts, 1:317–318, 427, 3:191  
 midi-skirts, 2:200  
 Minoan dress, 1:55  
 poodle skirts, 2:76  
 pouf, 2:327, 327, 3:20  
 tennis, 3:278  
 Vietnamese dress, 1:100  
*See also* Miniskirts  
 Skiwear, 2:102, 3:351  
 Skullcaps, 1:80, 2:285–286  
 Slack tension weave, **3:419**  
 Slaves  
 branding, 1:186  
 carnival dress, 1:230–231  
 cosmetics, 1:296  
 cotton production, 1:306  
 West African dress, retention of, 1:14–15  
 Sleepwear  
 nightgowns, 2:454–455  
 pajamas, 3:13–15  
 Sleeves  
 kosode, 2:303  
 sleeve dancing, 1:263  
 Slickers, 3:2–3  
 Slimane, Hedi, 3:383  
 Slip dresses, 3:192  
 Slips, 2:357, **3:191–192**  
 Slogans, 3:342–343  
 Slouch look, 1:406–407  
 Slovakian folk dress, 2:95  
 Slub yarns, 3:458  
 Smith, Graham, 2:185, 413  
 Smith, John Raphael, 1:226, 227  
 Smith, Paul, 2:432, **3:192**, 238, 438  
 Smith, Willi, **3:192–193**  
 Smith & Sons Ltd., 3:359  
 Smith patterns, 3:26  
 Smithsonian Institution, 2:86–87  
 Sneakers, 3:170–171, 172, **193–197**, 214–215  
 Snoods, 2:192  
 Snow, Carmel  
 Avedon, Richard and, 1:104  
 Cashin, Bonnie and, 1:232  
 editorship, 2:40  
 New Look, 2:451  
 professional associations, 3:57  
 Vreeland, Diana and, 3:406  
 Soap, 2:337, 337–340, 338  
 Sobol, Beth, 2:335  
 Soccer  
 fashion and, 1:239–240  
 uniforms, 3:378–380  
 Social aspects of dress  
 Afrocentric fashion, 1:28, 30  
 Barthes, Roland, 1:127–128  
 Baudelaire, Charles, 1:131–132  
 Baudrillard, Jean, 1:132–134  
 Benjamin on French fashion, 1:147–148  
 Brummell, George, 1:341  
 cosmetics, 1:295  
 courtesans, 1:356  
 gender, 2:128–133  
 impression management, 1:378  
 Lucile, designs of, 2:364–365  
 Marx, Karl, 2:387–388  
 masks, 2:392–393  
 nudism, 2:458–459  
 pockets, 3:42  
 religious dress codes and social control, 3:98–99  
 retro style, 2:220–221  
 school uniforms, 3:374–378  
 Simmel, Georg, 3:185–186  
 social change and fashion, 2:23  
 social power, 3:50–51  
 striped cloth, 3:229  
 Sub-Saharan Africa, 1:24  
 Veblen, Thorstein, 3:390–391  
 Social class and status, **3:197–199**  
 acquisition of clothing, 1:424  
 Australian dress, 1:102  
 ball dress, 1:112  
 Balzac's observations on fashion and, 1:118  
 Baudelaire, Charles, 1:131  
 Baudrillard, Jean, 1:133  
 beards and mustaches, 1:136  
 caricature and fashion, 1:225–228  
 ceremonial costumes, 1:244–245  
 Chinese dress, 1:83, 260–261, 262  
 cocktail dresses, 1:274  
 colonialism, 1:277–279  
 Communist dress, 1:287  
 conspicuous consumption, 1:74–75, 2:163, 3:118–119, 198, 390–391  
 cosmetics, 1:296  
 court dress, 1:312–313  
 debutante dress, 1:348–349  
 Egypt, ancient, 1:54  
 fashion models, 2:59  
 fingernail length, 2:437  
 fur, 2:115–116  
 gloves, 2:146  
 Hermès products, 2:201  
 India, 2:238  
 jewelry, 2:277–278  
 lingerie, 2:357  
 Macaroni dress, 2:367–368  
 mourning dress, 2:425–426  
 necklaces, 2:443



- Nepal, 1:90  
 occult dress, 1:1  
 occupational uniforms, 3:369–370  
 Ottoman Empire dress, 2:406–407  
 Pacific Islands, 1:96  
*pagnes*, 3:11  
 penis sheaths, 3:29  
 rings, 3:109  
 role of women's dress, 1:426  
 saris, 3:140  
 school uniforms, 3:375–377  
 shawls, 3:161  
 shrouds, 3:181  
 Southeast Asian dress, 1:98  
 Southeast Asian textiles, 3:315  
 spangles, 3:203  
 Spanish dress, 3:207  
 Sub-Saharan African dress, 1:24  
 sumptuary laws, 3:238–239  
 tea gowns, 3:271  
 togas, 3:330  
 trickle-down theory, 2:46, 78  
 umbrellas, 3:357  
 Veblen, Thorstein, 3:390–391  
 veils, 3:393  
 white shirts, 3:162  
 women's dress, 2:131  
 women's hats, 2:183  
 women's tailored suits, 3:259–260  
*See also* Wealth
- Social criticism, 3:432  
 Social differentiation, 3:185–186  
 Socialism  
 Cuba, 2:334  
 nudism, 2:459  
 Russia, 1:286–287  
 Socialites *vs.* courtesans, 1:356  
 Soghdian textiles, 3:289–290  
 Soil resistance finishes, 3:33  
 Sokolsky, Melvin, 2:401  
 Sokoto caliphate robes, 3:112, 113  
 Solar cells, 3:274  
 Solco hair products, 2:162  
 Soldiers  
 t-shirts, 3:341  
 tattoos, 3:269  
*See also* Military uniforms
- Soles, 3:166  
 Solubility of dyes, 1:388  
 Solvents, dry cleaning, 1:383–384  
 Solvyn, François Baltasar, 2:17  
 Somali dress  
 Islamic dress, 2:253  
*jilbab*, 2:289  
 veils, 3:392–393  
 Somatometers, 3:263  
 Somerville, Philip, 2:413, 3:116  
*Son Attese la femme* (Uzanne), 3:384  
 Song dynasty, 1:263–264, 2:106–107, 3:294, 294  
 Song Meiling, 3:71  
*The Song of the Shirt* (Hood), 3:150, 151  
*The Sonny and Cber Comedy Hour* (television show), 2:369–370
- Sophistication  
 De La Renta, Oscar, 1:350–351  
 Diana, Princess of Wales, 1:364  
 Soubise, Julius, 2:367  
 South African ceremonial costume, 1:241  
 South America  
 knitting, 2:308–310  
 tapestries, 3:266  
 South American dress, **1:45–49**, 47  
 bark cloth, 1:125  
 cosmetics, 1:294  
 dance dress, 1:339  
 ethnic dress, 1:416  
 gaucho dress, 1:314, 315  
*See also* Latin American fashion
- South Asian dress, **1:85–92**, 86, 3:138–140  
 South Asian textiles, **3:308–312**  
 South Korea, 2:42  
 Southeast Asia, 3:167  
 Southeast Asian dress, **1:93–97**, **97–101**  
 Black Tai Vietnamese women, 1:99  
 ikat, 2:232, 233  
 Indonesian couple, 1:94  
 Javanese wear, traditional, 1:95  
 Polynesian man with tattoos, 1:93  
 sarongs, 3:141–142  
 Thai royal dress, 1:98  
 Vietnamese family, 1:100  
 Southeast Asian textiles, **3:312–315**, **315–318**
- Soviet Union  
 Communist dress, 1:286–288  
 teenage fashion, 3:276  
 Space age styles, **3:199–200**  
 Cardin, Pierre, 1:224, 2:450  
 costume jewelry, 1:305  
 Space suits, 2:198, **3:200–202**, 201  
 Spade, Kate, 2:173  
 Spain  
 China, trade with, 3:292  
 textiles, 3:303  
 Spandex  
 elastomers, 1:405  
 girdles, 2:140  
 ski clothing, 3:188–189  
 swimwear, 3:254  
 Spangles, **3:202–3:203**, 338  
 Spanish dress and fashion, **3:203–3:208**  
 Balenciaga, Cristóbal, 1:107–111  
 Baroque fashion, 1:424  
 carnival dress, 1:230  
 cloak dress, 3:116–117  
 colonialism, 1:47–48, 2:333, 3:284–285  
 court dress, 1:312  
 cowboy clothing, influence on, 1:314–315  
 farthingales, 3:191  
 folk dress, 2:100, 101  
 mantillas, 2:193  
 Renaissance style, 1:423  
 Sparta, 1:321
- Spears, Britney, 1:336  
 Special effects makeup, 3:325  
 Specialization, 1:400, 3:38, 287, 295  
 Specialty stores, 3:2600  
 Spectacles, 1:432  
 Speculative production, 3:84  
 Speedo, 1:103  
 Sperry, Paul, 3:214  
 Spice Girls, 1:336  
 Spill, George, 3:79  
 Spindler, Amy, 2:54  
 Spindler, William, 1:384  
 Spindles, 3:208–209, 209  
 Spinning, **3:208–211**, 209  
 African textiles, 3:282  
 wool, 3:442  
 worsted, 3:446  
 yarns, 3:456  
 Spinning machinery, 3:209–211, **211–212**  
 Spiral line, 1:268  
 Splits, 2:344–345  
 Sponsored *vs.* spontaneous fads, 2:1–2  
 Sport sandals, 3:136  
 Sport shirts, **3:212–213**  
 Sport shoes, **3:213–216**, 214, 215  
 children's, 3:170–171  
 sneakers, 3:193–197  
 women's, 3:177  
 Sports bras, 1:192, 3:361–362  
 Sports helmets, 2:197–198  
*Sports Illustrated*, 1:156, 3:250  
 Sports jackets, 2:257, **3:216–217**  
 Sports photography, 2:63–64  
 Sports uniforms, **3:378–382**, 379  
 Sportswear, 3:217, **217–221**, 218, 219, 220  
 Armani, Giorgio, 3:20  
 Beene, Geoffrey, 1:140  
 bicycle clothing, 1:154  
 bloomers, 1:163  
 brands and labels, 1:188  
 for casual dress, 3:275  
 celebrities, 1:239–240  
 Ellis, Perry, 1:405–407  
 embedded sensors, 3:273  
 flappers, 2:88  
 golf clothing, 2:149–150  
 headwear, 2:184  
 hip-hop, 2:216–217, 3:276  
 Italian futurist fashion, 2:119  
 jumpers, 2:291  
 Klein, Calvin, 2:306  
 knickerbockers, 1:194–195  
 McCardell, Claire, 2:396–398  
 Patou, Jean, 3:22–23, 24  
 polo shirts, 3:52  
 protective clothing, 3:60  
 Schiaparelli, Elsa, 3:145  
 shirtwaists, 3:164  
 skating dress, 3:186–188  
 ski clothing, 3:188–189  
 Smith, Willi, 3:192  
 sport shirts, 3:212–213

- Sportswear (*continued*)  
 sports jackets, 3:216–217  
 striped cloth, 3:229  
 suits, influence on, 3:237  
 sweaters, 3:244–245  
 t-shirts, 3:342  
 tailored suits, 3:260  
 tennis costumes, 3:279  
 tweeds, 3:347  
 windbreakers, 3:433  
 Windsor, Duke of, 3:437  
 women's athletic wear, 2:133  
*See also* Activewear; Casual wear;  
 Leisurewear
- Sporty suits, 3:260–261  
 Spectra, 3:3  
 Sprouse, Stephen  
 logos, 2:360  
 Vuitton, Louis, 3:408
- Spurs, 1:315  
 Square dance costumes, 1:337–338  
 Square toe shoes, 3:176–177  
 Sri Lankan dress, 1:88, 90, 3:310  
 Stafford, Paula, 1:103  
 Stage fashion shows, 2:53, 70  
 Stain resistance finishes, 3:33  
 Stair, Rosalind, 3:23  
 Stalin, Josef, 1:286–288  
 Stallybrass, Peter, 2:387  
 Stamou, Katerina, 2:98  
 Stand and bobbin equipment, 1:185  
 Standardization  
 shoe measurement, 3:164–165  
 sizing, 3:86, 263  
 weave type terminology, 3:421–422  
 Staple yarns, 3:455–456  
 Starr, Blaze, 3:231  
 Static electricity, 3:443  
 Status symbols  
 Missoni, 2:416  
 sunglasses, 3:241  
 Treacy, Philip, labels of, 2:414  
 Vuitton, Louis, 3:408  
 Steamship travel, 3:333–334  
 Steel buttons, 1:207–208  
 Steele, Lawrence, **3:221–222**  
 Steele, Valerie  
 fashion history, 2:19  
 Fashion Institute of Technology  
 Museum, 2:61  
 Macaroni dress, 2:368  
 on Youthquake, 3:459
- Steichen, Edward  
 fashion advertising, 2:28  
 fashion editors and, 2:40  
 Horst, Horst P. and, 2:226  
 Hoyningen-Huene, George and,  
 2:228  
 modernism, 2:62  
 Steinkirks, 2:444  
 Stemp, Sindy, 2:429  
 Stencil dyeing, 3:301  
 Stencil printing, 1:387
- Stepanova, Varvara, 1:286, 3:126, 413  
 Stephen, John, 3:237, 263, 461  
 Stephens, Frederic George, 2:368  
 Stereotypes  
 Macaroni dress, 2:368  
 occult dress, 3:2  
 Stern, Bert, 2:64, 65  
 Stetson hats, 2:179, 181  
 Stewardess uniforms  
 Balenciaga, Cristóbal, 1:110  
 Pucci, Emilio, 3:65  
 Stickley, Gustav, 3:412  
 Stibel, Victor, 2:361  
 Stiletto heels, 3:177  
 Stilettoes, 2:204, 205  
 Stitch resist dyeing, 3:327  
 Stitching, 1:203, 3:301–302  
 Stockings, 3:223, **223–225**  
 flappers, 2:89  
 nylon, 2:461, 3:272  
*See also* Hosiery
- Stockman, Fred, 2:377  
 Stoddard solvent, 1:384  
 Stoles, 1:117  
 Stoller, Robert, 2:80  
 Stone Island, 2:432  
 Storey, Helen, 3:399  
 Storm, Tempest, 3:231  
 Storm, Tempest, 3:231  
 Story quilts, 3:317  
 Storytelling masks, 2:388–389  
 Strass, Georges Frédéric, 2:282  
 Stratton, Charles and Lavinia, 1:359  
 Straw hats, 2:411, 411  
 Strawberry Hill project, 2:219  
 Street style, **3:225–228**, 226, 227, 228  
*cholos*, 2:335, 336  
 dance costume, 1:336  
 dandyism, 1:345  
 dashikis, 1:347  
 Dolce & Gabbana, 1:371  
 fashion designers', inspiration for, 2:36  
 future of fashion, 2:118  
 Gaultier, Jean-Paul, 2:127  
 hip-hop, 2:214–218  
 London fashion, 2:362  
 punk, 3:68  
 Rhodes, Zandra, 3:104  
 Soviet Union, 1:288–289  
 trickle up theory, 2:21–22, 46  
 Yamamoto, Yohji, 3:454–455  
*See also* Subcultures; Urban dress
- Streetstyle* (Polhemus), 3:236  
 Strengell, Marianne, 3:413  
 Stretch fabrics, 1:224  
 Stretched ear piercings, 1:167  
 Strik handbag, 2:173  
 Strike branding, 1:186, 187  
 Striped cloth, **3:229–230**  
 Striptease, **3:230–232**, 231  
 Strobe lights, 3:63  
 Structure, weave, 3:422  
 Strutt, Joseph, 2:17  
 Stubble. *See* Beards and mustaches
- Student dress codes, 3:50  
 Studio 54, 2:47  
 Studs. *See* Cuff links and studs
- Style  
 fashion/style distinction, 2:83  
 Laver, James, 2:342–343  
 The Style Network, 2:71  
*Style with Elsa Klensch* (television show),  
 2:40–41, 53, 70  
 Sub-Saharan African dress, **1:19–25**  
 Subcontracting  
 garment production, 2:143–144  
 ready-to-wear, 1:401–402  
*Subculture The Meaning of Style*  
 (Hebdige), 3:68  
 Subcultures, **3:232–236**, 233, 234, 235  
 beards and mustaches, 1:137  
 body piercing, 1:167–168  
 bohemian dress, 1:170–172  
 cosmetics, 1:299  
 costume jewelry, 1:304  
 dashikis, 1:347  
 fads, 2:2  
 fetish fashion, 2:80–81  
 goths, 2:150–152  
 grunge, 2:153–154  
 hip-hop style, 2:214–218  
 hippie style, 2:218–219  
 identity, 2:35  
 Modern Primitives, 2:235, 420–421  
 New Romantics, 2:432  
 occult dress, 3:2  
 punk, 3:66–69  
 safety pins, 1:196  
 scarification, 3:144  
 Soviet Union, 1:288–289  
 street style, 3:225–228  
 sweatshirts, 3:246  
 tattoos, 3:270  
 teenage fashion, 3:276  
*See also* Street style
- Subkoff, Tara, 1:222  
 Subscription debutante balls, 1:348–349  
 Substantive dyes, 1:388, 389  
 Suburbs, 1:403  
 Sudden Infant Death Syndrome (SIDS),  
 3:273
- Sui, Anna  
 camouflage cloth, 1:219  
 Clark, Ossie, influence of, 1:269  
 folklore look, 2:103  
 grunge, 2:154
- Suits, **3:237–238**  
 Adrian, 1:11  
 Chanel, Gabrielle (Coco), 1:252,  
 253  
 dinner suits, 1:274  
 dress for success, 1:379  
 tailored, 3:131, 259–261, 348  
 Sulfur dyes, 1:388  
 Sullivan, J. E., 3:214  
 Sullivan, Louis, 1:362  
 Sumerian jewelry, 2:278

- Sumptuary laws, **3:238–239**  
 China, 1:262  
 Europe, 1:422  
 fur, 2:115  
 Japanese textiles, 3:300  
 Middle Ages, 3:197–198  
 politics and fashion, 3:51  
 shoes, 3:173–174  
 social class and status, 2:14  
 spangles, 3:203  
 Sun Yat-sen suits. *See* Mao suits  
 Sunbathing, 3:252  
 Sundback, Gideon, 3:465  
 Sunglasses, **3:240–242**, 241  
 Sunrise Dance, 1:241  
 Supermarkets, 3:179–180  
 Supermodels, 2:59, **3:242–244**, 243, 244  
   Capucci's opposition to, 1:222  
   fashion icons, 2:47  
   1990s, 3:353  
   promotion of, 2:70  
 Supernumerary gender, 1:319  
 Supreme Court robes, 2:348  
 Surfwear, 1:103, 3:246  
 Surgical steel implants, 2:235, 421  
 Surplices, 1:396–397  
 Surrealism  
   Beaton, Cecil, 1:137–138  
   Bourdin, Guy, 1:177–179  
   fashion photography, 2:64  
   mannequins, 2:379  
   Schiaparelli, Elsa, 3:145–146  
   window displays, 3:434–435  
 Sutcliffe, John, 3:121  
 Sutherland, Douglas, 2:67  
*Suzan dozi* embroidery, 3:291  
 Suzie Wong dress, 3:6–7  
 Swaddling, 1:256, 256, 3:169–170  
 Swan, Joseph, 3:82  
*Swan Lake* (ballet), 3:43  
 Sweaters, 3:22–23, **3:245–246**, 245  
 Sweatshirts, **3:246–247**  
 Sweatshops, **3:247–250**, 248  
   economics and clothing, 1:403  
   globalization of production, 2:143–144, 145  
   London, 2:361–362  
   regulations, 2:51  
   shirtwaist factories, 1:164  
 Sweden  
   court dress, 1:313  
   folk dress, 2:97, 98  
 Swimwear, **3:250–255**, 252, 253, 254  
   Australia, 1:103  
   bikinis, 1:155–157  
   Gernreich, Rudi, 2:136  
   Kamali, Norma, 2:296  
   McCardell, Claire, 2:397  
   Orientalism, 3:6  
   tankinis, 1:157  
   textiles, 3:219  
   thongs, 1:156–157  
 Swing dress, 1:339  
 Switzerland  
   folk dress, 2:99–100  
   watch industry, 3:411  
 Swoosh, 3:197  
 Sword sticks, 1:220  
 Sy, Oumou, **3:255–257**  
 Symbolism  
   barber poles, 1:119  
   Bhutanese textiles, 3:311  
   black, 3:119  
   black as color choice, 3:454  
   bogolan, 1:170  
   bracelets, 1:184  
   canes and walking sticks, 1:220  
   ceremonial costumes, 1:245–246  
   color, 1:282, 3:1  
   cosmetics, 1:293–295  
   crowns and tiaras, 1:324  
   dashikis, 1:347  
   Eastern European folk dress, 2:94, 96  
   Egypt, ancient, 1:54  
   feathers, 2:74  
   gay identity signifiers, 2:31–32  
   Ghost Dance movement, 1:244  
   handbags, 2:170  
   headdresses, 2:194  
   heraldry, 1:69  
   Indian dress, 2:238–239  
   Islamic dress, 2:250–251, 406  
   jewelry, 2:280, 3:1–2  
   Korean fashion, 2:316–317  
   legal and judicial costume, 2:348  
   Pacific Island dress, 1:95–96  
   *pagnes*, 3:11–12  
   penis sheaths, 3:30  
   religion and dress, 3:96, 99  
   sandals, 3:135  
   Seydou, Chris, 3:160  
   Southeast Asian textiles, 3:315, 317  
   subcultures, 3:233–234  
   turbans, 3:344  
   umbrellas and parasols, 3:357  
   veiling, 2:212–213  
   wedding costumes, 3:2227  
   white, 3:119  
   working-class dress, 3:444  
   zippers, 3:466  
   zoot suits, 3:467  
 Le Syndicat de la Couture de Paris  
   Callot sisters, 1:216  
   fashion shows, 2:69  
   Lanvin, Jeanne, 2:330  
   Theatre de la Mode, 2:38, 39  
 Syndicated pattern services, 3:26  
 Synthetic dyes. *See* Dyes, chemical and synthetic  
 Synthetics  
   acrylic and modacrylic, 1:2–3  
   cotton, as alternative to, 1:308  
   elastomers, 1:405  
   fibers, 2:82  
   fur, 2:116  
   Gernreich, Rudi, 2:137  
   indigo, 2:242  
   neckties, 2:447  
   1950s, 3:350–351  
   nylon, 2:461–462  
   olefin, 3:3  
   polyester, 3:52–54  
   saris, 3:139–140  
   shrinkage control, 3:32  
   silk alternatives, 3:184  
   techno-textiles, 2:207–208, 3:272–273  
   tennis costumes, 3:279  
   travel clothing, 3:334  
   wigs, 3:431  
   Youthquake fashion, 3:461  
 Syria, 3:307  
*Le Système de la Mode* (Barthes), 1:127
- T**
- T-shirts, 2:84, **3:341–343**  
 Tabby weave. *See* Plain weave  
 Taglioni, Marie, 1:115, 3:43  
 Tailor and Cutter Academy, 1:331  
 Tailored costume defined, 1:51  
 Tailored suits, women's, 3:131, **259–261**, 348  
 Tailoring and tailors, 3:85, **261–264**  
   cutting, 1:330–331  
   immigrants, 3:86  
   Margiela, Martin, 2:381  
   patterns, 3:25, 26, 3:26  
   Savile Row, 3:142–143  
   Spain, 3:204  
   suits, 3:237  
   Trigère, Pauline, 3:337  
   uniforms, 3:349  
   Windsor, Duke of, 3:436–437  
   *See also* Dressmaking; Seamstresses  
 Taisho period, 2:261, 305  
 Takada, Kenzo. *See* Kenzo  
 Take That, 1:336  
 Takizawa, Naoki, 2:420  
 Talbot, 2:62  
 Talbot, Suzanne, 2:412  
 Taliban, 2:133, 253  
 Talley, André Leon, 3:440  
 Talliths, 2:286, 286  
 Talon, Inc., 3:465  
 Tam, Vivienne  
   ethnic style, 1:417, 418  
   folklore look, 2:103  
   Orientalism, 3:7  
   paper dress, influence of the, 3:16  
 Tam-o'-shanters, 1:150  
 Tambouring, 1:318  
 Tamils, 1:89  
 Tampere University of Technology, 3:273  
 Tanaka, Ciyo, 3:4



- Tang dynasty, *1:261, 262–263, 3:294*  
Tango dress, *1:334–335, 339, 3:6, 348*  
Tankinis, *1:157*  
Tanning, *1:386, 2:343–345, 3:264–265*  
Tap-dance shoes, *1:340*  
Tapa. *See* Bark cloth  
Tape measures  
cutting and, *1:331*  
tailoring, *3:263*  
Tapestries, **3:266–267**  
Byzantine Empire, *3:287*  
handwoven, *2:174*  
Japanese, *3:300–301*  
*Kesi*, *3:294, 294*  
Le Brun, Charles, *3:118*  
prehistoric, *3:307*  
tabby-tapestry, *3:298, 299*  
Tapestry, **3:266–267**  
Tarabuco dancers, *1:45*  
Tarrant, Naomi, *2:19*  
Tartan, *2:301–302, 3:267, 267–268, 437*  
Taste, *2:342–343*  
Tatlin, Vladimir, *1:286*  
Tattoos, **3:268–271, 269**  
blackwork, *2:420–421*  
henna, *1:21–22, 294*  
Maori people, *1:244–245*  
occult dress, *3:2*  
Southeast Asian and Pacific Islands, *1:93*  
Taxi dresses, *2:258*  
Taylor, Elizabeth, *3:388–389*  
Taylor, Niki, *3:243*  
Taylor, Paul, *1:339, 340*  
Tchelitchev, Pavel, *2:228*  
Tcherassi, Silvia, *2:335*  
Tea gowns, **3:271–272**  
Liberty & Co., *2:354*  
Lucile, *2:364–365*  
Tear Drop Tiara, *1:325–326*  
Tech packs, *2:36*  
Techno music, *2:431–432*  
Techno-textiles, *2:37, 3:189, 272–274, 332*  
Technology  
activewear, *1:4*  
art production, *2:49–50*  
body-scanning, *2:57–58*  
fashion illustration, *2:49*  
and future of fashion design, *2:37*  
health and dress, *2:45*  
helmets, *2:197, 198*  
high-tech fashion, *2:205–209, 206, 207*  
Inuit and arctic clothing, *2:245, 247–248*  
machine-made wool felt, *2:76*  
military uniforms, *3:368*  
ready-to-wear production, *3:88*  
skating dress, *3:187*  
ski clothing, *3:189*  
watches, *3:411*  
weaving machinery, *3:424–425*  
Teddy, *2:357*  
Teddy Boys, *3:226*  
London fashion, *2:362*  
revivals, *2:220*  
street style, *3:225*  
tailoring, *3:263*  
teeage fashion, *3:276*  
Teenage fashion, **3:274–277**  
*See also* Youth culture  
Tefillin phylacteries, *2:285, 2:285*  
Teflon implants, *2:235, 421*  
Television  
caricature and fashion, *1:229*  
fashion journalism, *2:53–54*  
home-shopping retailers, *3:102*  
Teller, Juergen, *2:203*  
Temperature regulating textiles  
activewear, *1:4*  
future of fashion, *2:117*  
health and fashion, *2:45*  
high-tech fashion, *2:209*  
performance finishes, *3:34*  
space suits, *3:202*  
techno-textiles, *3:273*  
Temperley, *3:399*  
Temporary tattoos, *3:270*  
Tencel, *3:82, 83*  
Tennis costumes, *3:220, 277, 277–279, 278*  
Tennis shoes, *3:195*  
Terminology  
braiding, *1:184–185*  
breeches, *1:192–193*  
calico, *1:213*  
casual business dress, *1:236*  
chemise, *1:254*  
clothing, costume and dress, *1:270–271*  
cool, *2:217–218*  
dandy, *1:117*  
dandyism, *1:343*  
demand, *1:401*  
draped *vs.* tailored, *1:51*  
dress, *1:63*  
eonism, *1:323*  
ethnic, *1:414*  
fads, *2:1*  
fashion, *1:401, 2:12–13*  
fashion victim, *2:2*  
flame resistant *vs.* flame retardant, *3:33*  
flappers, *2:88*  
folk dress, *1:414*  
gabardine, *2:122*  
*hijab*, *2:209–210, 211*  
homespun, *2:222–223*  
hosiery, *2:227*  
Korean traditional dress, *2:313*  
lingerie, *2:356*  
Macaroni, *2:368*  
mantua, *2:379*  
medieval style garments, *1:420*  
merchandising, *2:57*  
models, *2:58*  
nudity, *2:460*  
polyester, *3:52–53*  
recycled textiles, *3:91*  
robes and gowns, *3:110–111*  
sex *vs.* gender, *2:129*  
sneakers, *3:194*  
striptease, *3:230*  
supermodels, *3:242*  
tartan, *3:267*  
tea gowns, *3:272*  
teenagers, *3:275*  
tiaras, *1:324*  
toga dresses, *3:330*  
traditional dress, *3:331*  
transvestism, *1:323*  
trends, *2:1*  
tuxedo, *2:110*  
veils, *3:391–392*  
weave types, *3:421–422*  
wool, *3:441*  
*See also* Glossaries  
Terrace Casual style, *1:345*  
Terry cloth, *3:415*  
Testino, Mario, *2:110, 416*  
Texas A&M Drill Team, *3:365*  
Texas debutantes, *1:349*  
Textile Fiber Products Identification Act (TFPIA), *2:319–320*  
Textile workers, *3:306, 319, 320–322*  
Textiles, **3:279–318**  
acrylic and modacrylic, *1:2–3*  
*adire*, *1:8–10*  
African, *3:159–160, 279–283*  
alpaca, *1:36–37*  
Andean countries, *1:46, 3:283–288*  
animal prints, *1:59–60*  
Australian, *1:102–103*  
bark cloth, *1:96, 125–126, 126*  
Beene, Geoffrey, *1:140, 141*  
Belgian, *1:143*  
bogolan, *1:169–170, 3:159*  
braiding, *1:184–185*  
Byzantine, *3:286–288*  
calico, *1:213–215, 217*  
cambric, batiste, and lawn, *1:217*  
camouflage cloth, *1:218–219*  
cashmere and pashmina, *1:233–236*  
Central American and Mexican weaving, *1:38–40*  
Central Asian, *3:288–291*  
China, ancient, *1:261*  
Chinese, *1:260, 3:291–296*  
chintz, *1:266–267*  
Coptic, *3:296–299*  
corduroy, *1:289–290*  
cotton, *1:306–309*  
crepe, *1:316*  
Delaunay, Sonia, *1:351–352*  
denim, *1:359–360*  
double weaves, *3:414–415*  
Egypt, ancient, *1:54*  
ethnic, *1:415–416, 3:99*  
felt, *2:75–76*  
flannel, *2:87–88*  
Fortuny, Mariano, *2:113–114*  
France, *2:186*  
gabardine, *1:201, 2:122, 3:420*

- glazing, 2:142–143  
 Greece, 1:55–56  
 handwoven, 2:174–175  
 hemlines and textile manufacturers, 2:199  
 hemp, 2:200–201  
 high-tech, 2:37  
 homespun, 2:222–224  
 ikat, 2:231–233  
 India, 2:239–240  
 indigo dyeing, 2:241–242  
 Jacquard weaving, 3:415  
 Japan, 2:266, 270, 3:299–302  
 Japonisme, 2:271, 272  
 jersey, 2:276–277  
 kanga, 1:346–347, 2:297–298  
 kente, 1:20, 245, 2:299–300  
 knitting, 2:307–309  
 labeling laws, 2:319–320  
 labor issues, 2:386–387  
 Liberty & Co., 2:354  
 linen, 1:55, 2:355–356  
 Marimekko, 2:383–385  
 Middle Eastern, 3:302–305  
 Middle Eastern Islamic dress, 2:403  
 Missoni, 2:416  
 Miyake's choices of, 2:418–419  
 muslin, 2:434, 434–435  
 napping, 2:439–440  
 nonwoven, 2:455–456  
 North African dress, 1:17–18  
 nylon, 2:461–462  
 Orientalism, 3:4–5  
 Ottoman Empire, 2:407  
 Pacific Islands, 1:96  
 paisley, 3:12–13  
 performance finishes, 3:32–34  
 pile weave, 3:415–416  
 plain weave, 3:416–417, 417, 423  
 prehistoric, 3:305–308  
 proverb cloths, 2:297–298  
 ramie, 3:81  
 rayon, 3:81–84  
 recycled, 3:90–92, 92  
 rites of passage costumes, 1:242  
 Rome, ancient, 1:57  
 Russian, 3:125  
 satin weave, 3:417–419, 418  
 Scottish, 3:149  
 silk, 3:182–184  
 silk production, 1:82–83  
 slack tension weave, 3:419  
 South Asian, 3:308–312  
 Southeast Asian, 3:312–315, 315–318  
 Spanish, 3:206  
 spinning, 3:208–211  
 striped cloth, 3:228–230  
 synthetics and Youthquake fashion, 3:461  
 tapestries, 3:266  
 tartan, 3:267–268  
 techno-textiles, 2:37, 3:189, 272–274, 332  
 technologically advanced, 1:4  
 tennis costumes, 3:279  
 Thai, 1:99–100  
 trade, 1:400–401  
 traditional dress, 3:332  
 tweeds, 3:149, 346–348  
 twill weave, 3:419–421, 420  
 velvet, 3:394  
 vinyl, 3:400–401  
 wearable art, 3:413  
 weave types, 3:421–422  
 weaving, 3:423  
 Worth, Charles Frederick, 3:448  
 yozen, 2:304  
*See also* Fibers
- Textiles and international trade, 3:318–320, 321  
 TFPIA (Textile Fiber Products Identification Act), 2:319–320  
 Thaarup, Aage, 2:413  
 Thackeray, William Makepeace, 1:343  
 Thai dress, 1:98, 1:98–100, 415, 2:194  
 Thayaht. *See* Michahelles, Ernesto  
 Theater, fashion shows as, 2:67–68  
 Théâtre de la Mode, 2:38, 39, 73  
 Theatrical costumes, 3:322–324  
 Barbier, Georges, 1:124  
 Beaton, Cecil, 1:137–138  
 Broadway and fashion, 1:335–336  
 Chanel, Gabrielle (Coco), 1:252  
 Delaunay, Sonia, 1:352  
 designers, 1:300–302  
 Dior, Christian, 1:365, 366  
 historical studies of fashion, 2:17  
 Japan, 2:266–270  
 Lucile, 2:365  
 makeup artists, 2:374–375  
 masks, 2:388–389  
 musical-dance, 1:340  
 Norell, Norman, 2:457  
 Rabanne, Paco, 3:78  
 Valentina, 3:387–388  
*See also* Costume design; Film and fashion
- Theatrical makeup, 3:324–325, 325  
*See also* Cosmetics; Makeup artists  
 Theologians, 2:405  
 Theory of fashion, 2:21–27  
 Baudrillard, Jean, 1:132–134  
 conceptual fashion, 2:20  
 fashion *vs.* ethnic clothing, 1:417  
 Flügel, J.C., 2:90–91  
 Laver, James, 2:342–343  
 Marx, Karl, 2:387–388  
 Simmel, Georg, 3:185–186, 198, 203  
 social class and status, 3:197–199  
 subcultures, 3:236  
 trickle-down theory, 2:46, 3:336  
 Veblen, Thorstein, 1:394–395, 423–424, 2:18  
*See also* Historical studies of fashion  
*The Theory of the Leisure Class* (Veblen), 1:426, 2:15, 16, 18, 3:198, 390–391
- Thermal energy, 3:274  
 Thermal Micrometeoroid Garment (TMG), 3:202  
*Theses on the Philosophy of History* (Benjamin), 1:148  
 Theyskens, Olivier, 1:145, 2:372  
 Thimonnier, Barthélemy, 3:157  
 Third Reich, 2:8–12  
 Thirty Years' War, 2:444  
 Thonburi period, 1:99–100  
 Thongs, 1:156–157, 2:121–122  
 Thorpe, John, 3:212  
 “A Thousand and One Nights” (ballet), 3:5  
 Three-dimensional body modification, 2:235  
 Three motives model of change in fashion, 2:343  
 Three-piece suits, 1:423, 424, 425, 3:236–237  
 Tiaras. *See* Crowns and tiaras  
 Tibet, 1:85, 236, 3:311  
 Tie-dyeing, 2:242, 3:63, 3:325–328, 327  
 Tie-on pockets, 3:42  
 Tiegs, Cheryl, 3:243  
 Ties, 1:185  
*See also* Neckties and neckwear  
 Tight-lacing, 3:328–329  
 Tights, 3:224  
 Tilaka, 1:293–294  
 Timberlake, Justin, 1:336  
 Time, 2:342, 401  
 Timor, 1:184  
 Timurid Empire, 3:289  
*Tinker vs. Des Moines Independent School District* (1969), 3:50  
 Tinling, Teddy, 3:278  
 Tiraz, 2:404, 3:303  
 Tirta, Iwan, 1:130, 2:295  
 Titanic, 3:439  
 TMG (Thermal Micrometeoroid Garment), 3:202  
 Toe shoes. *See* Pointe shoes  
 Togas, 1:20, 57–58, 3:329, 329–331  
 Toledo, Isabel and Ruben, 3:331–333  
 Toledo, Ruben, 2:49  
 Tonner, Robert, 2:39  
 Tools  
 shoemaking, 3:164–165  
 spinning, 3:208–211  
*Toosh*, 1:235  
 Top hats, 2:179  
 Topkapi Saray Museum, 2:406  
 Topless bathing suit, 2:136  
 Topolino, 2:375  
 Torry, Richard, 2:432  
 Total Look  
 Albini, Walter, 1:35  
 Gemreich, Rudi, 2:136  
 Toudouze, Anais, 2:66  
 Tour de France, 1:155  
*Townsend's Quarterly Selection of Parisian Costumes*, 2:55

- Tozer, Jane, 1:329  
*Tracht*, 2:9, 99  
 Trade  
   African textiles, 3:281  
   Asian/western, 3:4–5  
   beads, 1:135  
   calico, 1:213, 215, 217  
   Central Asian textiles, 3:288–289  
   Chinese/Greek, 1:55–56  
   Chinese imports in Australia, 1:102–103  
   chintz, 1:267  
   cotton, 1:306  
   fans, 2:7  
   fur, 2:115–116, 427  
   garment, 2:126–127  
   handwoven textiles, 2:175  
   Indian textiles, 3:309  
   Japanese textiles, 3:300  
   Japanese/Western, 2:261  
   Ming dynasty, 3:295  
   ready-to-wear, 3:84, 86  
   restrictions, 3:319–320  
   secondhand clothing, 3:151–153  
   silk, 3:182, 286–287  
   Southeast Asian textiles, 3:316  
   Tang dynasty, 1:262–263  
   textiles, 1:400–401  
   traditional dress and textile trade, 3:332  
   umbrellas, 3:359  
 Trade, international textile, **3:318–320**, 321  
 Trade agreements and treaties  
   fur related, 2:116  
   Latin America, 2:335  
   migratory bird protection, 2:74–75  
   textile trade, 3:319–320, 321  
 Trademarks  
   aloha shirts, 2:189  
   brands and labels, 1:187  
   Velcro, 1:270  
 Traditional dress, **3:331–333**  
   Indonesia, 1:94, 94, 95  
   Korea, 2:313–317, 314, 315, 316  
   North American indigenous peoples, 1:42–45, 44  
   Peru, 1:47  
   Russian dress, 3:122, 3:124–125  
   Vietnamese, 1:99, 1:99, 100  
   *See also* Ethnic dress  
 Traditional Japanese textiles, 3:302  
 Traeger, Ronald, 3:355  
 Traina, Anthony, 2:457  
 Trainers, 3:197  
 Training  
   cutters, 1:331  
   fashion schools, 2:36  
   haute couture, 2:187  
   lace-making, 2:326  
*Traité de la vie élégante* (Balzac), 1:117, 118  
 Transparent handbags, 2:172  
 Transsexual surgery, 3:41  
 Transvestism. *See* Cross-dressing  
 Trapeze Line, 1:35–36  
 Trapping, 2:116  
 Travel clothing, **3:333–334**  
 Travolta, John, 1:336  
 Treacy, Philip, 1:327, 2:413, 414, 414, **3:334–335**  
 Treadle looms, 2:174  
 Treadles, 3:210  
 Treaties. *See* Trade agreements and treaties  
*Treatise on the Elegant Life. See* *Traité de la vie élégante* (Balzac)  
 Trébutien, Guillaume-Stanislas, 1:343  
 Trémolet, Gérard, 2:351  
 Trench coats, 2:410, 3:79, 121  
 Trends  
   fads *vs.*, 2:1  
   Madonna and style trends, 2:372  
   movie-related, 2:84–85  
   skating dress, 3:188  
   theatrical costumes, 3:323–324  
 Trendsetters, **3:335–336**, 436–438  
   *See also* Fashion icons  
 Triangle Shirtwaist Company, 1:164  
 Tribal carpets, 3:304  
 Tribal tattoos, 3:270  
 Tribute, 3:316–317  
 Trick or treat, 2:166, 167  
 Trickle-down theory, 2:46, 3:198, **3:336**  
 Trickle-up theory, 2:46, 3:199, 225, 227  
 Trico, Joseph, 2:310  
 Tricorn hats, 2:179  
 Trigère, Pauline, 1:275, **3:336–337**, 337  
 Trimmings, **3:337–339**, 3:371  
 Trinta, Joaosinho, 1:231  
*Trio World Fashion Tour*, 2:70  
 Triolet, Elsa, 3:146  
 Tritik, 1:387  
 Troop, 2:216  
 Troubridge, Una, 1:344, 2:33  
 Trousers, **3:339**, **339–341**, 340  
   batik, 1:130  
   bloomerism, 1:381–382  
   breeches, as alternative to, 1:194  
   breeching, 1:256–257  
   Chanel, Gabrielle (Coco), fashions of, 1:252  
   De La Renta, Oscar, 1:350  
   Duke of Windsor, 3:436–437  
   girls', 1:259–260  
   sportswear, 3:218  
   suits, 3:237  
   twentieth century fashion, 3:349  
   women's, 1:161–163, 350  
   women's sportswear, 3:220  
   World War II, 2:11  
   Youthquake fashion, 3:460–461  
 True weave, 3:305–306  
 Trunk hose, 1:193  
 Truss, 3:339  
 TSE, 2:310  
 Tsumura, Kosuke, 1:4  
 Tswaki, Ed, 2:49  
 Tuffin, Sally, 3:459, 460  
 Tunics  
   ancient world, 1:51–52  
   Bhutan, 1:90  
   Central Asian dress, 1:78  
   Coptic, 3:298–299  
   Egypt, ancient, 1:54  
   Greece, ancient, 1:56–57  
   Iran, 2:248, 249  
   Rome, ancient, 1:58  
   Turkmenistan, 1:80–81  
 Tunisian crochet, 1:318  
 Turbans, **3:343–345**  
   India, 2:237  
   royal, 2:194  
   women's, 2:183  
 Turbeville, Deborah, 2:65  
 Turkey  
   Chinese dress, influence on, 1:262  
   Islamic dress, 2:253  
   Orientalism, 3:4–5  
   veils, 3:393  
 Turkmenistan, dress of, 1:80–81, 81  
 Turlington, Christy, 3:243  
 Turmeric, 2:238  
 Turner, Tina, 1:33  
 Turnshoes, 3:168  
*Tuta*, 3:383–384  
 “Tuta,” 2:119  
 Tuxedos, 2:110–112, **3:345–346**  
 Tweeds, **3:346–348**, 347  
   equestrian costume, 1:413  
   Scottish dress, 3:149  
   yarns, 3:458  
 Twelfth century, 1:419  
 Twentieth century, **3:348–353**  
   actors and actresses, 1:6  
   advertising, 2:28–29  
   Andean textiles, 3:285–286  
   art and fashion, 1:73–74  
   ballet costumes, 1:115–116  
   business suits, 3:237–238  
   children's clothes, 1:259–260  
   children's shoes, 3:171  
   Chinese dress, 1:264–265  
   coats, 1:273  
   cosmetics, 1:297–300  
   costume jewelry, 1:302–305  
   couture business, 1:403  
   dance and fashion, 1:334–336  
   debutante dress, 1:348–349  
   demimonde, 1:357  
   department stores, 1:362  
   dress shirts, 1:383  
   earrings, 1:393–394  
   evening dresses, 1:429, 429  
   eyeglasses, 1:433–434  
   fashion dolls, 2:38–39  
   fashion icons, 2:46–48  
   fashion magazines, 2:55–56  
   fashion photography, 2:62–65



- fashion plates, 2:67  
 gloves, 2:147  
 handbags and purses, 2:171–173  
 hemlines, 2:198–200, 3:190  
 high heels, 2:205  
 Japonisme, 2:271–272  
 jeans, 2:272–276  
 jewelry, 2:282–283  
 lace, 2:326  
 Latin American fashion, 2:334–335  
 London fashion, 2:362  
 marketing and distribution, 2:25  
 mass fashion, 2:26  
 maternity dress, 2:395–396  
 men's hats, 2:180–181  
 Middle Eastern Islamic dress,  
     2:408–409  
 military uniforms, 3:368  
 milliners, 2:412–414  
 mourning dress, 2:426  
 muffs, revival of, 2:428  
 neckwear, 2:447  
 occupational uniforms, 3:371–373  
 Orientalism, 3:5–7  
 outerwear, 3:9–10  
 pajamas as fashion, 3:14–15  
 Paris fashion, 3:19–21  
 ready-to-wear, 3:87–88  
 royal and aristocratic dress, 3:120  
 Savile Row, 3:142–143  
 scarification, 3:144–145  
 scarves, 3:143  
 secondhand clothes, 3:154  
 sewing machines, 3:158  
 shirtwaists, 3:164  
 shoemaking, 3:167–168  
 shop types, 3:179–180  
 Southeast Asian textiles, 3:316–318  
 sports jackets, 3:216  
 street style, 3:225–226  
 sunglasses, 3:240–242  
 swimwear, 3:252–254  
 t-shirts, 3:341–343  
 tailoring, 3:263–264  
 tattoos, 3:269–270  
 textile workers, 3:320  
 theatrical costumes, 3:323–324  
 tiaras, 1:326–327  
 umbrellas and parasols, 3:358–359  
 waistcoats, 3:410  
 wearable art, 3:412, 413–414  
 wigs, 3:430–431  
 women's hats, 2:184–185  
 women's shoes, 3:177  
 women's tailored suits, 3:259–261  
 wristwatches, 3:410–411  
 zippers, 3:465–466  
*See also* Specific decades  
 Twenty-first century  
   cosmetics, 1:299–300  
   dandyism, 1:345  
   scarification, 3:144–145  
   secondhand clothes, 3:155  
   social class and clothing, 3:198  
   street style, 3:226–228  
   tattoos, 3:270  
 Twigg, 2:59, 64, 3:242, 351, **354–355**  
 Twill weave, 1:234–235, **3:419–421**, 420  
   *See also* Denim; Gabardine  
 Twining, 3:307–308, 312–313  
 Two-bar looms, 2:174  
 Tyler, Richard, 1:62  
 Tyrian dye, 3:287  
 Tyrolean dress, 2:99, 99, 102  
 Tyvek, 2:208  
 Tzara, Tristan, 3:146
- U**
- Ukraine, 2:94  
 Ultraviolet rays, 3:33–34  
 Umayyad dress, 2:404  
 Umbrellas and parasols, **3:357–360**, 358  
 Undercutters, 1:331  
 Undershirts, 2:84  
 Undertones, 1:282  
 Underwear, **3:360–362**  
   advertising, 2:290  
   boxer shorts, 1:181–182  
   brassieres, 1:188–192  
   “fashion” lingerie, 3:73  
   g-strings and thongs, 2:121–122  
   girdles, 2:138–141  
   high-tech, 2:45–46  
   jockey shorts, 2:290  
   Klein, Calvin, 1:239, 2:306, 306–307,  
     3:353  
   lingerie, 2:356–357  
   as outerwear, 2:371  
   pantalets, 1:258  
   panties, **3:15**  
   petticoats, 3:37–38  
   satin, 3:418–419  
   slips, 3:191–192  
   t-shirts, 3:341–342  
   wool, 1:381  
   *See also* Corsets  
 Underwood, Patricia, 1:407, 2:414  
 Ungaro, Emanuel, 2:345, 3:200  
 Uniform Dress Law, 2:408  
 Uniforms, **3:362–382**  
   airline pilot, 3:369  
   Austrian postman, 3:370  
   British Royal footmen, 3:371  
   Brownies, 1:258  
   camouflage cloth, 1:219  
   fascist and Nazi dress for women,  
     2:10–11  
   formal wear, uniform nature of, 2:110  
   French Republican Guard, 3:363  
   girls in school uniforms, 3:377  
   gym, 2:133  
   Hong Kong boys in school blazers,  
     3:376  
   Mainbocher, 2:374  
   military style, 2:410  
   Navy, 2:440  
   prison dress, 3:55–57  
   production of jockeys' uniforms, 3:379  
   reenactors, 3:93–94  
   t-shirts, 3:342  
   Texas A&M Drill Team, 3:365  
   West Point cadets, 3:367  
   World War I, 3:349  
 Union-Alls, 2:273  
 Union of Needletrades, Industrial and  
   Textile Employees (UNITE), 2:51,  
   322  
 Union suits, 3:361  
 Unisex clothing, **3:382–384**  
   Cardin, Pierre, 1:224  
   Gernreich, Rudi, 2:137  
   headwear, 2:184  
   Italian futurist fashion, 2:119  
   modern-dance costumes, 1:339  
   1970s fashion, 3:351  
   rompers, 1:258  
   shoes, 3:172  
 Unitards, 1:337  
 UNITE (Union of Needletrades,  
   Industrial and Textile Employees),  
   2:51, 322  
 United Nations, 3:55  
 United States  
   bird protection legislation, 2:74–75  
   cotton production, 1:306  
   cross-dressing clubs, 1:323  
   diplomatic uniforms, 3:364  
   fashion education, 2:41–42  
   fashion museums and collections,  
     2:60–61  
   Halloween costumes, 2:165–167  
   history of dress, 1:418–425  
   industrial revolution, 1:425  
   Islamic dress, 2:253  
   legal and judicial costume, 2:348  
   *Made in USA* label, 2:320  
   mechanization of production, 1:402  
   milliners, 2:411, 414  
   prison dress, 3:55, 56  
   ready-to-wear, 3:86–89, 489–490  
   Roma, 3:114–115  
   sweatshops, 3:248–249  
   textiles, 3:318–319, 320–321  
   zippers, 3:465–466  
   *See also* American dress  
 Universal Fastener Company, 3:465  
 Universities  
   academic dress, 1:1–2  
   sweatshirts, 3:246  
 Upper/lower body distinction  
   Jewish dress, 2:284, 3:97  
   Roma, 3:114  
 Urban dress  
   camouflage, 1:345  
   Central American dress, 1:37–38  
   *cholos*, 2:335, 336

- Urban dress (*continued*)  
 fascist and Nazi dress, 2:9–10  
 India, 2:235  
 North Africa, 1:17  
 punk, 3:68  
 wearable PC, 2:207  
 Yamamoto, Yohji, 3:453–455  
*See also* Street style  
*Urban Latino* (magazine), 2:335  
 U.S. Rubber Company, 3:170–171, 195  
 USA Network, 2:53  
 Used clothing. *See* Secondhand clothes  
 Uzanne, Octave, **3:384–385**  
 Uzbekistan, dress of, 1:79, 79–80
- V**
- “V” silhouette, 1:11  
 Vacuum Persian fur, 2:78  
*La vague* style, 3:348  
 Valaya, J.J., 2:239  
 Valentina, 3:343, **3:387–388**  
 Valentino, **3:388–391**  
   Diana, Princess of Wales, and, 1:363  
   Italian fashion, 2:255  
 Valletta, Amber, 3:244  
 Vallhonrat, Javier, 2:65  
 Valois, Rose, 2:412  
 Value of colors, 1:281  
 Vampire fiction, 2:151, 3:2  
 Van Beirendonck, Walter, 1:144, 145, 2:208, 3:353  
 Van Cleef and Arpels, 3:438  
 Van Courtlandt Society, 1:349  
 Van de Velde, Henry, 3:412  
 Van Noten, Dries  
   Belgian fashion, 1:144  
   Clark, Ossie, influence of, 1:269  
   ethnic style, 1:417  
   fashions of, 1:145  
   Japonisme, 2:265  
   1990s fashion, 3:353  
 Van Saene, Dirk, 1:144  
 Vanderbilt, Gloria, 2:274  
 Vanderbilt, Mrs. W. K., 2:3  
 Vandevorst, An, 1:145  
*Vanity Fair* (magazine), 1:363  
*Vanity Fair* (Thackeray), 1:343  
*Vanity* (magazine), 2:49  
 Vanity Web sites, 2:61  
 Vaquero dress, 1:314, 315  
 Vara shoe, 2:79  
 Vat dyes, 1:388  
 Vatican II, 1:398, 3:99  
 Vaudeville, 3:230–231  
 Veblen, Thorstein, 1:426, 2:15–16, 18, 3:198, 390, **3:390–391**  
 Vegetable tanning, 3:264–265  
 Veils and veiling, **3:391–394**  
   ancient Mesopotamia, 1:52–53  
   chador, 1:246–247  
   dress reform, 2:408  
   Egyptian feminism, 2:253  
   gender and religious dress codes, 2:133  
   Greece, ancient, 1:57  
   *bijab*, 2:209–213  
   India, 2:238  
   Islamic dress, 1:369, 370  
   Roman brides, ancient, 1:58  
 Velcro, 1:270, 2:72  
 Velvet, **3:394–395**  
 Velvet Underground, 3:66  
 Venet, Philippe, 3:77  
 Venetia handbag, 2:173  
 Venice, Italy  
   beads, 1:135  
   lace, 2:325  
   secondhand clothes, 3:153  
 Venus figures, 3:305  
 Vera, 3:143  
 Verdingales, 3:191  
 Verhoeven, Julie, 2:49, 3:408  
 Vernet, Horace and Carle, 1:228  
 Versace, Donatella, **3:395–397**  
   celebrities, use of, 1:239  
   corsets, 1:292  
   folklore look, 2:103  
   Italian fashion, 2:255  
   Madonna and, 2:372  
 Versace, Gianni, 3:243, 395, **3:395–396**  
   appliqué, use of, 1:64  
   designer jeans, 2:275  
   Diana, Princess of Wales, and, 1:363, 364  
   fashion icons, 2:47  
   fetish fashion, 2:81  
   grunge, 2:154  
   hip-hop style, 2:217  
   homosexuality, 2:32  
   Italian fashion, 2:255  
   leather, 2:345  
   leather dress, 2:344  
   Madonna’s collaboration with, 2:372  
   1990s fashion, 3:353  
   retro-futurism, 2:430  
   supermodels, 3:243  
   tiaras, 1:326–327  
   transparent outerwear, 3:15  
 Versace, House of  
   celebrities, use of, 1:240  
   Hurley, Elizabeth, dress for, 1:238  
   logos, 2:360  
   Meisel’s advertising campaign for, 2:401  
 Vértes, Marcel, 2:49  
 Vertical ties. *See* Long ties  
 Verushka, 2:64  
 Vestments. *See* Ecclesiastical dress  
 Vever, Henri, 1:326  
 Vexed Generation, 1:4  
 VH1, 2:71  
 Victor, Sally, 2:185, 192, 413  
 Victoria, Queen  
   advertising, 2:27–28  
   crowns, 1:325  
   crowns and tiaras, 1:327  
   fancy dress, 2:4  
   Highland dress, 3:148–149  
   Highland style, 2:301  
   mourning dress, 2:425  
   parasols, 3:359  
   shoes, 3:176  
   wedding costumes, 3:426  
 Victoria & Albert Museum, 2:60  
 Victorian era  
   boots, 1:174  
   bustles, 1:204  
   consumption, 3:178  
   crinolines, 1:317–318  
   Cunnington garment collection, 1:328–329  
   dandyism, 1:343  
   equestrian costume, 1:412–413  
   gothic style, 2:219  
   Halloween, 2:167  
   jewelry, 1:303  
   London fashion, 2:362  
   maternity dress, 2:29  
   Orientalism, 3:5  
   shrouds, 3:181  
   style changes, 1:426–427  
   tea gowns, 3:271–272  
   *Theory of the Leisure Class* (Veblen), 2:15, 16  
   tight-lacing, 3:328–329  
   wedding costumes, 3:426  
   youth, 3:274  
 Victoria’s Secret  
   Internet marketing, 2:208  
   lingerie, 2:356, 357  
   supermodels, 3:244  
 Victorine, Madame, 2:411  
 Vicuñas, 1:37  
 Videofashion News, 2:70  
 Viel-Castel, Comte Horace de, 2:17  
 Vietnamese dress  
   *ao dai*, 1:60–62, 61  
   Black Tai women, 1:99  
   history, 1:84  
   pants and skirts, 1:100  
   traditional, 1:99  
 Viktor & Rolf, 3:397, **3:397–398**  
   art and fashion, 1:73  
   fashions of, 3:398  
   tuxedos, 3:345  
 Vintage fashion, **3:398–400**  
   dashikis, 1:347  
   designer clothing, 1:404  
   Internet sales, 2:61  
   jeans, 1:360, 2:275–276  
   secondhand clothes, 3:155  
   Von Furstenberg, Diane, fashions of, 3:406  
   Youthquake fashion, 3:461–462  
   *See also* Retro styles; Secondhand clothes  
 Vinyl as fashion fabric, **3:400–401**  
 Violence, 1:178

- Vionnet, Madeleine, **3:401–404**  
 Alaïa, Azzedine and, 1:33  
 art deco, 1:77  
 body proportion and dress, 1:73  
 Callot sisters, work with, 1:216  
 celebrity, 2:51  
 Chanel, as competitor to, 3:19  
 Clark, Ossie, influence on, 1:268  
 cocktail dresses, 1:274  
 Doucet, House of, 1:377  
 embroidery of Michonet, 2:350  
 fashions of, **3:401**  
 Japonisme, 2:271–272  
 kimono style, 2:265  
 neoclassicism, 2:220  
 1930s fashion, 3:350  
 revival of historical styles, 3:6  
 Steele, Lawrence, influence on, 3:222  
 Vreeland, Diana, patronage of, 3:406  
 Windsor, Duchess of, 3:438  
 Viramontes, Tony, 2:49  
 Vironi, Gianni, 3:468  
 Viscose rayon, 3:82, 83  
 Visé, Donneau de, 2:54  
 Visual color mixing, 1:282  
 Vitucci, Angelo, 2:386  
 Vivier, Roger, 2:204, 205  
 Vizé, Jean Donneau de, 2:66  
 Vladimir, Prince, 3:122, 123  
 Vocational and technical schools. *See*  
 Fashion education  
 Vogel, Lucien, 2:55, 67  
*Vogue*, **3:405**  
 1929 cover, 2:56  
 Avedon, Richard and, 1:105  
 Beaton, Cecil, 1:138–139  
 Bourdin, Guy, 1:177–178  
 caftans, 1:212  
 costume jewelry, 1:304  
 editorial slant, 2:54  
 editorship, 2:40  
 fashion illustration, 2:49, 67  
 Horst, Horst P., 2:224–225  
 Hoyningen-Huene, George, 2:228  
 Klein, Calvin, fashions of, 2:306  
 little black dress, 2:359  
 Meisel, Steven, 2:401–402  
 Penn, Irving, 3:30–31  
 trendsetters, 3:335  
 Twiggy, 3:355  
 Vreeland, Diana, 3:407  
 Volt, 2:118  
 Von Boehn, Max, 2:18  
 Von Furstenberg, Diane, 1:78, 434,  
**3:405–406, 406**  
 Von Runkle, Theodora, 3:323  
 Von Unwerth, Ellen, 2:65  
 Vreeland, Diana, **3:406–408, 407**  
 on bikinis, 1:156  
 caftans, 1:212  
 celebrity, 1:239  
 Chanel, Gabrielle (Coco), fashions of,  
 1:252  
 Clark, Ossie, influence on, 1:268  
 Costume Institute of the Metropolitan  
 Museum of Art, 2:60  
 costume jewelry, 1:303–304, 305  
 editorship of *Vogue*, 2:40, 3:405  
 on military dress, 2:409  
 Missoni style, 2:416  
*Romantic and Glamorous: Hollywood Style*  
 exhibit, 2:221  
 Saint Laurent exhibition, 3:132  
 Windsor, Duchess of, 3:438, 439  
 Windsor, Duke of, 3:438  
 on youthquake, 2:61  
 Vrubel', M., 3:125  
 Vuitton, Louis, **3:408**  
 accessories, 2:127  
 celebrities, use of, 1:240  
 logo, 2:360, 361  
 luggage, 2:171  
 military style, 2:410  
 Vulcanization of rubber, 3:120–121, 195,  
 214
- W**  
*W* (magazine), 2:56  
*Wabi-sabi*, 3:455  
 Wages  
 clothing workers, 1:403–404  
 garment workers at House of Chanel,  
 1:252  
 immigrant garment workers,  
 2:144–145  
 Wahlberg, Mark, 3:361  
 Waifs, 3:244  
 Waistcoats, **3:409–410**  
 Wakabayashi, Yasuhiro, 2:64  
 Walden, George, 1:344  
 Wales, 2:98  
 Walker, Catherine, 1:363–364  
 Walker, Madame C. J., 1:15, 16, 297  
 Walker Wear, 2:216  
 Walking sticks and canes, **1:219–221**  
 Walking suits, 3:259  
 Wallace, Barbara Markey, 1:398  
 Wallets, 2:170  
*Wallpaper\**, 2:49  
 Walpole, Horace, 2:219, 367  
 Waltzes, 1:334, 339  
 Wang, Vera, 3:36  
 War bonnets, 2:75, 194  
 War paint, 1:294  
 Ward, Jim, 1:167–168  
 Ward, Melanie, 2:203  
 Ward, Montgomery  
 ready-to-wear, 3:87  
 shirtwaists, 1:164–165  
 Warhol, Andy, 3:132, 396, 435  
 Warlocks. *See* Occult dress  
 Warm colors, 1:281–282  
 Warnings, fabric, 2:320  
 Warp-faced fabrics  
 gabardine, 2:122  
 twills, 1:359  
 Warp knits, 2:311  
 Warp stripes, 3:280  
 Warren, Lavinia, 1:359  
 Wash-and-wear  
 Brooks Brothers, 1:199  
 wrinkle resistance finishes, 3:32  
 Washing machines, 2:339–340  
 Wassau, Hinda, 3:230  
 Watanabe, Junya, 1:285, 2:208  
 Watch pockets, 3:41  
 Watches, **3:410–411**  
 Water-resistant clothing  
 Burberry, 1:200–202  
 health and, 2:45  
 Inuit and arctic, 2:245, 247–248  
 microfibers, 2:402  
 rubber, 3:121  
 techno-textiles, 3:272–273  
 Water spirit masks, 2:389  
 Waterbury Buttons, 1:208  
 Watkins, Liselotte, 2:49  
 Watteau pleats, 3:271  
 Waugh, Jacinta Numina, 1:102  
 Waugh, Nora, 2:19  
 Wax resist dyeing. *See* Batik  
 Wayfarer style sunglasses, 3:241  
 Wealth  
 Bhutanese textiles, 3:311  
 conspicuous consumption, 3:390–391  
 jewelry as repository of, 2:278  
*See also* Social class and status  
 Wearable art, 2:305, **3:411–414**  
 Wearable electronics, 2:207, 209,  
 3:273–274  
 Weather protection  
 health and, 2:45  
 microfibers, 2:402  
 protective clothing, 3:58  
 ski clothing, 3:189  
 umbrellas and parasols, 3:357–360  
 Weave types, **3:421–422, 423**  
*See also* Double weave; Jacquard weave;  
 Pile weave; Plain weave; Satin  
 weave; Slack Tension weave; Twill  
 weave  
 Weaving, **3:423–424**  
 ancient China, 3:292–294  
 Baltic folk dress, 2:93–94  
 Byzantine textiles, 3:286–287  
 card weaving, 1:185  
 Central America and Mexico, 1:38–40  
 Central Asian textiles, 3:290–291  
 Coptic textiles, 3:298  
 double weaves, 3:414–415  
 handweaving revival, 3:413  
 Japanese textiles, 3:300–301  
 looms, 2:362–364  
*lurik*, 3:314  
 Middle East, 3:304  
 prehistoric textiles, 3:305–307



- Weaving (*continued*)  
 shawls, 3:161  
 Southeast Asia, 3:312–313, 315–318  
 striped cloth, 3:228–229  
 tapestries, 3:266  
 wool, 3:442  
*See also* Textiles
- Weaving machinery, 3:424–425
- Web forming, 2:455–456
- Weber, Bruce, 2:65, 226, 3:396
- Weber, Max, 3:198
- Wedding costumes, 3:425–427  
 bridal hood, 2:193  
 Central Asia, 1:243  
 Central European folk dress, 2:95  
 Diana, Princess of Wales, 1:363  
 Fontana sisters, 2:104  
 headdresses, 2:194–195  
 ikat, 2:233  
 India, 2:238, 2:238–239  
 Kamali, Norma, 2:296  
 Middle Ages, 1:419  
 North Africa, 1:17, 18, 243  
 saris, 3:140  
 satin, 3:418  
 Swedish folk dress, 2:97  
 tiaras, 1:327  
 Tunisia, 1:243  
 Uzbekistan, 1:80  
 veils, 1:58, 3:392, 3:393  
 white, 3:119  
 Windsor, Duchess of, 3:438  
*See also* Ceremonial and festival costumes
- Wedding rings, 3:109
- Wedgwood, Josiah  
 buttons, 1:208  
 fashion showings, 1:402  
 jewelry, 2:282
- Weft knits, 2:311
- Weight-training, 1:166
- Wellington boots, 1:174
- Wenders, Wim, 3:453
- West, Mae, 1:357
- West Africa  
 Afrocentric fashion, 1:28, 30  
*agbada*, 1:30–32  
 boubous, 1:175–177  
 caftans, 1:212  
 cosmetics, 1:294  
 hair braiding, 2:158–159  
 looms, 2:174  
*pagnes*, 3:11–12  
 rites of passage costumes, 1:242  
 robes of honor, 3:113  
 slaves' retention of West African dress, 1:14–16  
 textiles, 3:279–282
- West Point cadets, 3:367
- Western dress and fashion  
 African influence on, 3:160  
 Afrocentric fashion and, 1:28  
 beards and mustaches, 1:136–137  
 berets, 1:150  
 body ideals, 2:130  
 bohemian dress, 1:172  
 bustles, 1:204–205  
 caftans, 1:212  
 Central American urban areas, 1:37–38  
 colonialism, 1:277–280  
 cosmetics, 1:295–300  
 dance and, 1:334–336  
 dress for success, 1:378–380  
 ethnic dress and style, 1:414–418  
 extreme fashion, 1:430–432  
 folklore look, 2:102–103  
 India, 2:236, 3:310  
 Indonesia, 1:94, 94  
 Islamic dress *vs.*, 2:251  
 Japanese fashion, influence of, 2:265, 271–272  
 Japanese fashion, influence on, 2:260–261, 261, 270, 304  
 Middle Eastern Islamic dress, influence on, 2:408  
 Miyake's opposition to, 2:418, 420  
 modernity, 2:24  
 nail polish, 2:437  
 Nehru jackets, 2:450–451  
 Orientalism, 3:4–7  
 Pacific Islands, 1:96–97  
 Russia, 1:286  
*salwar-kameez*, 3:134  
 sarongs, 3:142  
 Southeast Asia, influence on dress of, 1:100  
 Soviet Union, 1:288  
 subcultures, 3:232–233  
 teenage fashion, 3:274–277  
 wedding costumes, 3:425, 426–427
- Western European dress and fashion, 2:97, 97–102, 99, 101  
 beards and mustaches, 1:137  
 education, 2:42  
 maternity dress, 2:394–395
- Western wear  
 buckles, 1:147  
 folk dance, 1:337–338  
 jeans, 2:273
- Westphal, Katherine, 3:413
- Westwood, Vivienne, 2:128, 3:427–429, 428  
 advertising, 2:29  
 art and fashion, 1:72  
 caricature, 1:229  
 corsets, 1:292, 3:361  
 costume design, 2:222  
 crochet, use of, 1:319  
 fashion icons, 2:47  
 fetish fashion, 2:80–81  
 Gaultier, Jean-Paul and, 2:127  
 knitwear, 2:310  
 London fashion, 2:362  
 McQueen, Alexander, compared to, 2:400  
 music and fashion, 2:433  
 New Romantics, 2:432  
 1990s fashion, 3:353  
 1970s fashion, 3:352  
 petticoats, 3:38  
 punk, 1:432, 3:20, 67–68, 455  
 Scottish textiles, 3:149  
 sweaters, 3:245  
 sweatshirts, 3:246  
 tartan, 3:268  
 tiaras, 1:326  
 tweeds, 3:347, 348  
 vintage fashion, 3:399
- Wheeler, Nathan, 3:86
- Whistler, James McNeill, 1:344, 3:412
- White  
 shirts, 3:162  
 symbolism, 3:119  
 tennis costumes, 3:277–278  
 Umayyad dynastic color, 2:404  
 wedding costumes, 3:427  
 wedding dresses, 3:119, 426  
 White, Anne, 3:279  
 White, Clarence, 2:28  
 White, Nancy, 2:40  
 White, Rob, 3:234  
 White cloth, 3:316–317  
 White-tie, 2:111  
 Whiteley, William, 1:362  
 Whiteness, 3:94  
 Whitework, 1:408  
 Whitney, Eli, 3:211  
 Whitney, Gertrude Vanderbilt, 2:62  
 Whole garment knitting, 2:37  
 Whorls, 3:209–210, 212  
 Wicca. *See* Occult dress  
 Wickham, Henry, 3:120
- Wicking  
 linen, 2:355  
 olefin, 3:3
- Widgies and bodgies, 3:234
- Widows, 2:425–426
- Wife-dressing, 2:92
- Wigs, 3:429–431, 430  
 adornments, 2:159  
 ancient world, 2:161  
 blonde, 2:162  
 Eighteenth century, 2:160  
 Jewish dress, 2:285  
 legal and judicial costume, 2:347, 348
- Wilcox, Claire, 2:19, 60
- Wilde, Oscar, 3:431–433, 432  
 aesthetic movement, 1:12  
 aestheticism, 1:426  
 dandyism, 1:343–344, 345  
 trial for homosexuality, 3:61
- Willaumez, H. Bouet, 2:67
- Willhelm, Bernhard, 1:145, 222, 3:246
- Williams, Esther, 3:250, 3:254
- Williams, Venus, 3:278
- WilliWear Limited, 3:193
- Wilson, Allen B., 3:86
- Wilson, Elizabeth, 2:19, 34
- Wilson's of Bannockburn, 3:268

- Wimbledon, 3:277, 278  
 Windbreakers, **3:433–434**  
 Window displays, **3:434–436**, 435  
   boutiques, 1:180  
   department stores, 1:363  
   figures, 2:38  
   Quant, Mary, 3:73  
 Windsor, Duke and Dutchess of,  
   **3:436–439**, 437  
   dinner jackets, 3:345  
   Edwardian fashion, 3:348  
   as fashion icons, 2:46  
   golf clothing, 2:149  
   Mainbocher, 2:373, 373  
   tattoos, 3:270  
 Windsor knot, 3:437  
 Wing collared shirts, 1:383  
 Wintour, Anna, 2:41, 3:405  
 Wipers, 3:91–92  
 Wireless communications, 3:273  
 Witches. *See* Occult dress  
 Woad, 2:241  
*The Woman's Dress for Success Book*  
   (Molloy), 1:152–153, 164, 3:190  
 Women  
   apparel industry labor, 3:88  
   barbershop patronage, 1:119–120  
   bodybuilding and sculpting, 1:165  
   Central American and Mexican  
     weavers, 1:38–39  
   cosmetics entrepreneurs, 1:297  
   department store customers, 1:362  
   domestic production, 1:373–374  
   embroidery, 3:295  
   fashion editors, 2:55  
   fashion historians, 2:18–19  
   guild of tailors, 1:424  
   shopping, 3:178  
   Southeast Asian weavers, 3:314,  
     317–318  
   *See also* Working women  
 Women's dress and fashion  
   African Americans, 1:15–16  
   Afro hairstyles, 1:25–27  
   ancient Greece, 1:57  
   athletic dress, 2:133  
   attacks on fashion, 2:13–14  
   bark cloth, 1:125  
   Baudelaire on, 1:131  
   Bloomer costume, 1:161–163,  
     381–382, 426, 3:13–14  
   bohemian dress, 1:172  
   business attire, 1:237, 3:238, 341  
   bustles, 1:204–205, 317, 427  
   cache sexe, 1:211–212  
   Central American and Mexican, 1:40  
   chador, 1:246–247, 247  
   dandyism, 1:344  
   dress for success, 1:152–153, 164,  
     378–379, 3:190  
   Egypt, ancient, 1:54  
   ethnic dress, 1:414–415  
   flappers, 2:88–89, 138, 164, 3:275, 461  
   Flügel, J.C., 2:91  
   footbinding, 1:431, 2:106–109, 132  
   future of fashion, 2:117  
   hair bobbing, 2:164, 165  
   hemlines, 1:250, 2:85, 198–200, 3:190,  
     352  
   hip-hop, 2:214–215  
   'imama, 2:294  
   Indian dress and marital status,  
     2:238–239  
   Indonesia, 1:94  
   Iran, 2:249  
   Islamic, 1:369–370, 2:252  
   Jewish dress, 2:284–285  
   Korea, 2:314, 314, 315  
   Latin America, 2:334  
   leisure wear, 3:219  
   masculinized fashions, 2:133  
   maternity dress, 2:394–395  
   morality, 2:13–14  
   nautical style, 2:441  
   Paris fashion, 3:19–21  
   pockets, 3:41–42  
   production, 1:402  
   psychological aspects, 1:328–329  
   punk, 3:235  
   reform, 1:381–382  
   Roma, 3:115–116  
   simplicity, 1:131  
   skirt supports, 3:190–191  
   social class and status, 1:426  
   sportswear, 3:218, 218–220  
   sumptuary laws, 3:239  
   tweeds, 3:347  
   twentieth century, 3:348–353  
   Uzanne, Octave, writing of, 3:384–385  
   Veblen, Thorstein, 3:391  
   veiling, 1:52–53, 369–370, 2:209–213,  
     3:392–394  
   Youthquake fashion, 3:458–461  
   *See also* Specific designers; Specific  
     items of clothing  
 Women's hats, **2:181–186**, 182, 183,  
   184  
 Women's shoes, **3:173–3:178**, 176  
*Women's Wear Daily*, **3:439–441**  
   editorial slant, 2:54  
   influence on fashion scene, 2:56  
 Wonder, Stevie, 1:347  
 Wong, Anna May, 3:184  
 Wood  
   canes and walking sticks, 1:219  
   sandals, 3:135  
 Woods, Tiger, 3:219  
 Wool, **3:441–443**  
   alpaca, 1:36–37  
   Central Asia, 3:289  
   China, 1:265  
   dress reform, 1:381  
   felt, 2:75–76  
   flannel, 2:88  
   fulling, 2:114–115  
   health aspects, 2:44  
   labeling laws, 2:319  
   Mesopotamian dress, 1:52  
   Middle East, 3:304  
   saya, 2:96  
   shrinkage control, 3:32  
   tailoring, 3:262  
   tsocha, 2:96  
   worsted, 3:446  
   yarn production, 3:456  
 Woolf, Virginia, 1:344  
 Work clothing  
   Hugo Boss, 2:229  
   Levi Strauss, 2:351–353  
   protective clothing, 3:60  
   youth style, 3:276  
 Workers' rights. *See* Labor issues  
 Working-class dress, **3:443–446**  
   Japanese, 1:84–85  
   punk style, 3:68  
   *See also* Occupational uniforms  
 Working women  
   blouses, 1:164  
   cosmetics, 1:297  
   Courrèges, André, 3:200  
   Salwar-kameez, 3:134  
   tailored suits, 3:259–260  
   trousers, 3:220, 349  
   working-class dress, 3:445  
 World Trade Organization (WTO),  
   3:320  
 World War I  
   cellulose acetate, 3:82  
   Chanel, Coco, fashion of, 2:46  
   fashion, 3:349  
   fashion shows, 2:69  
   hairdressers, 2:160–161  
   military uniforms, 3:368  
   plastic surgery, 3:40  
   ski clothing, 3:188  
   tattoos, 3:269  
   trench coats, 3:80  
   women's shoes, 3:177  
 World War II  
   American fashion designers, 2:36  
   Amies, Hardy, 1:50  
   Balenciaga, Cristóbal, 1:108–109  
   camouflage cloth, 1:219  
   Chanel, Gabrielle (Coco), 1:252  
   coats, 1:273  
   cocktail dresses, 1:275  
   cosmetics, 1:298–299  
   costume jewelry, 1:304  
   fashion, 3:350  
   fashion photography, 2:64  
   German clothing cards, 2:11  
   girdles, 2:139  
   Grès, Madame, 2:152  
   hairstyles, 2:164  
   haute couture, 2:187  
   hemlines, 2:199  
   hemp, 2:200  
   Japan, 2:305  
   jeans, 2:273

- World War II (*continued*)  
 Mainbocher, 2:373  
 military style, 2:410  
 Paris fashion houses, 3:20  
 sandals, 3:136  
 Schiaparelli, Elsa, 3:147  
 stockings, 3:224, 3:225  
 swimwear, 3:250  
 t-shirts, 3:341  
 tattoos, 3:269, 270  
 women's shoes, 3:177  
 zoot suits, 3:467–468  
*See also* 1940s
- Worst-dressed lists, 1:152
- Worsted, 2:114, **3:446–447**
- Worth, Charles Frederick, *3:447, 447–449*  
 as artistic bohemian, 1:73  
 courtesans, designs for, 1:356  
 embroidery, use of, 1:408  
 embroidery of Michonet, 2:350  
 fashion shows, origins of, 2:67  
 haute couture, 1:425, 2:36, 186–187  
 international reputation, 2:51  
 models, use of, 2:58  
 Paris couture, origins of, 1:402  
 Paris fashion, 2:13, 3:19  
 Regent Street emporium, 2:362
- Worth, Gaston, 3:348
- Worth, House of  
 art nouveau, 1:76  
 brands and labels, 1:187  
 fashion plates, 2:67  
 garment trade, 2:126  
 Poirer, Paul, 3:44  
*See also* Worth, Charles Frederick;  
 Worth, Gaston; Worth, Jacques;  
 Worth, Jean-Philippe
- Worth, Jacques, 1:216
- Worth, Jean-Philippe, 3:348, 448, 449
- Worth, Marie, 2:58
- Wrappers, **3:11–12**  
*adire*, 1:9  
 Demeulemeester, Ann, 1:354  
 ethnic dress, 1:415  
 gowns, 2:395  
 India, 2:235, 2:236  
 South Asia, 1:86  
 Southeast Asian dress, 1:98–99,  
 3:141–142  
 Sub-Saharan African dress, 1:19, 20  
 togas, 3:330  
 Vionnet, Madeleine, 3:402–404  
 Von Furstenberg, Diane, 3:405–406
- Wreaths, 1:324
- Wright, Frank Lloyd, 3:412
- Wrinkle resistant fabric  
 Brooks Brothers, 1:199  
 finishes, 3:32–33  
 travel clothing, 3:334
- Wrinkling  
 cotton, 1:308  
 linen, 2:355
- Wristwatches, 3:410–411
- Writers  
 Balzac, Honoré de, 1:117–119  
 Barthes, Roland, 1:127–128  
 Benjamin, Walter, 1:147–148  
 Hawes, Elizabeth, 2:190–191  
 Proust, Marcel, 3:60–62  
 Uzanne, Octave, 3:384–385  
 Wilde, Oscar, 3:431–433, 432
- WTO (World Trade Organization),  
 3:320
- Wyatt, John, 3:212
- X**
- Xanith, 1:320
- Xuly Bët, **3:451–452**
- Y**
- Yacht clubs, 2:440–441
- Yamamoto, Kansai, 2:433
- Yamamoto, Yohji, **3:453–455**  
 ethnic style, 1:417  
 Fashion and Textile Museum, 3:105  
 Japanese fashion, 2:263, 264  
 Japonisme, 2:272  
 knitwear, 2:310  
 little black dress, 2:360  
 men's fashion, 3:353  
 Miyaki, Issey and, 2:418  
 New Look, homage to the, 2:451  
 1980s fashion, 3:352  
 Paris fashion, 3:20  
 sweatshirts, 3:247  
 t-shirts, 3:343  
 technology and fashion, 2:208  
 unisex clothing, 3:384  
 Vionnet, Madeleine, influence of,  
 3:404
- Yang Weizhen, 2:108
- Yarmulke, 2:285–286
- Yarns, **3:455–458**  
 designer knitting, 2:310  
 dyeing, 1:385–386  
 spinning, 3:208–211  
 wool production, 3:441–442  
 worsted, 3:446
- Yellow dyes, 1:389
- Yellow ribbons, 3:107–108
- Yeohlee, **3:458–459**  
 ethnic style, 1:417  
 paper dress, influence of the, 3:16
- Yorkshire tweeds, 3:346–347
- Yoruba  
*agbada*, 1:30–32  
 ceremonial costumes, 1:245  
 headdresses, 2:194  
 identity and dress, 1:243  
 indigo, 3:281  
 weaving, 3:280
- Young, Andrew, 1:347
- Youth culture  
 advertisements, 2:28  
 baseball caps, 2:181  
 bikinis, 1:156–157  
 body piercing, 1:167–168  
 bohemian dress, 1:171–172  
 boutiques, 1:179–181  
*cholo* style, 2:335, 336  
 cosmetics, 1:299  
 Courrèges, André, 1:309–310  
 debutantes, 1:348–349  
 fads, 2:2  
 fashion icons, 2:47  
 flappers, 2:88–89  
 folklore look, 2:103  
 goths, 2:150–152  
 grunge, 2:153–154  
 hemlines, 2:199–200  
 heroin chic, 2:203  
 hip-hop, 2:214–218  
 hippie style, 2:218–219  
 Japanese, 2:262–263  
 jeans, 2:273–275  
 kilts, 2:302  
 London fashion, 2:362  
 mannequins, 2:379  
 miniskirts, 2:415–416  
 Nehru jackets, 2:450–451  
 1950s, 3:382–383  
 punk, 3:66–69  
 Quant, Mary, 3:73  
 safety pins, 1:196  
*sapeurs*, 3:137  
 Simons, Raf, 1:145  
 Soviet Union, 1:288–289  
 street style, 3:225–228  
 subcultures, 3:232–236  
 twentieth century, 1:260  
 Westwood, Vivienne, 3:428–429  
 Youthquake fashion, 3:459–462  
*See also* Music and fashion; Street style;  
 Teenage fashion
- Youth Dew (perfume), 3:36
- Youthquake fashion, **3:459–462, 460, 461**  
 Courrèges, André, 1:309–310  
 fashion icons, 2:47  
 revival of styles of, 3:103
- Yozen style, 2:304
- Y's 3, 3:455
- YSL brand, 2:110
- Yuan dynasty, 1:264, 3:294–295
- Yukata, *3:462, 462–463*
- Yuzen*, 3:301



**Z**

- Zaitsev, Slava, 3:126  
 Zambia, 3:152  
 Zara, 3:206  
 Zegna, Ermenegildo, 2:254, 255  
 Zeitgeist, 2:342, 401  
 Zen Buddhist robes, 3:111, 111  
 Zhou dynasty, 3:293  
 Zimmermann, Nicole, 1:103
- Zippers, 3:465–466  
   on handbags, 2:171  
   Hermès, 2:202  
   invention, 2:72  
   as technological innovation, 2:207  
   vs. buttons, 1:209
- Zippodt, Patricia, 3:323  
 Zita, Queen of Austria-Hungary, 3:117  
 Zola, Emile, 1:356
- Zoot suits, 3:466–468, 467  
   African American dress, 1:16  
   music and fashion, 2:432  
   tailoring, 3:263
- Zoran, 3:468  
 Zoroastrianism, 2:249  
 Zubets, Viktor, 3:127  
 Zucca, 2:420  
 Zulu, 1:241



**Woman in "Chinese" slacks and a jacket.** Stylistic conventions from diverse cultures spanning the Asian continent have been a source of inspiration for fashion designers since the seventeenth century. (See Orientalism) John S. Major. Reproduced by permission.



---

**Top: Ancient sandals.** Sandals are the oldest form of footwear. These leather sandals from Egypt date from the fourth millennium B.C.E. (See Sandals) © Gianni Dagli Orti/Corbis.

**Middle: Eighteenth-century shoe with clog.** By the eighteenth century, shoes of varying heels were in use. The English heel, as pictured in this example from 1750–1760, was thicker and low to mid-height. (See Shoes, Women's) Courtesy of the Bata Shoe Museum, Toronto. Reproduced by permission.

**Bottom: Art Deco style shoe, 1922–1925.** By the 1920s, heels grew taller and colored footwear began to appear, though it was seen as inappropriate for anything other than evening wear. (See Shoes, Women's) Courtesy of the Bata Shoe Museum, Toronto. Reproduced by permission.

---







---

*Portrait of a Lady with Spindle and Distaff*, (1531) by **Maerten van Heemskerck**. The flyer wheel, such as the one shown here, rotates faster and continuously winds yarn as it is spun. (See Spinning) The Fundación Colección Thyssen-Bornmisza. Reproduced by permission.

---







---

**Carved printing blocks.** Intricately carved printing blocks are used to decorate textiles. In the twentieth century, modern textiles replaced much of this traditional production. (See Textiles, Middle Eastern) © Arthur Thevenart/Corbis.

---







---

**Top: Embroidered silk robe.** Ever since the domestication of the silkworm around the third millennium B.C.E., silk has been the favored fabric of the Chinese upper class. (See Textiles, Chinese; China: History of Dress) © Christie's Images/Corbis.

**Middle: Coptic textile fragments.** An estimated 150,000 of these archeological fabrics were found in Egyptian burial sites, representing the fashions and furnishings of Egypt's Coptic period, dating from the late third- to mid-seventh centuries. (See Textiles, Coptic) Henry Art Gallery, University of Washington, Seattle, Helen Stager Poulsen Collection, 83.7-56, 93.7-57, 83.7-58. Photo credit: Richard Nicol. Reproduced by permission.

**Bottom: Iranian fabric printer.** This artisan is using a wooden printing block to print fabric by hand. With its fine details and complex coloring, Iranian designs have been considered to be among the finest in the Middle East. (See Textiles, Middle Eastern) © Corbis.

---

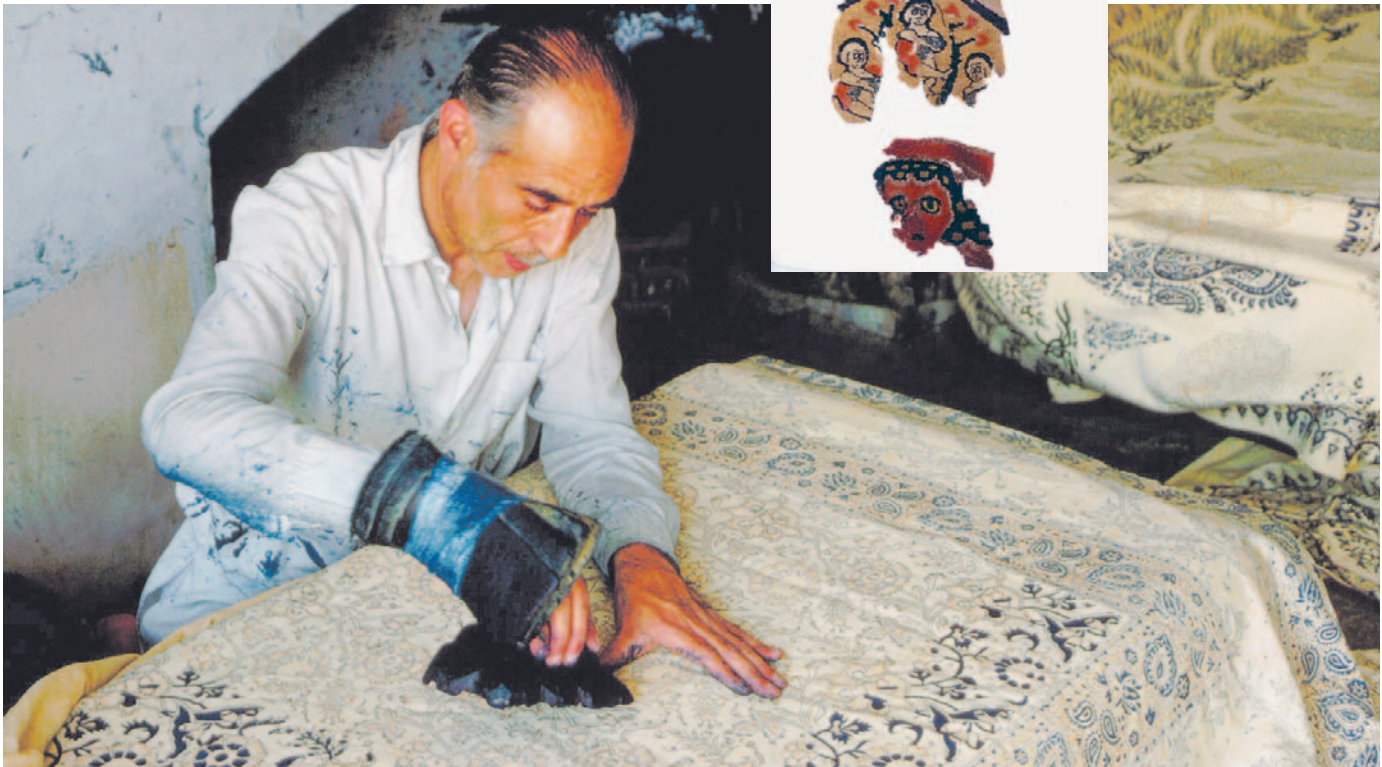
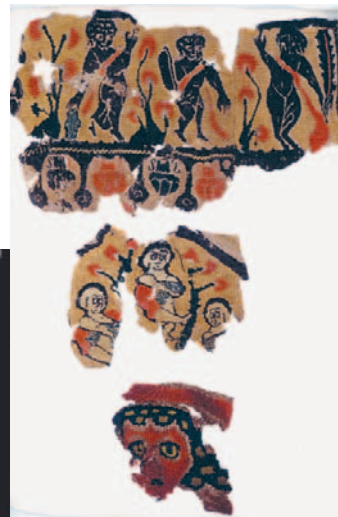





**Top left: Chinese wedding costumes.** Both the bride and groom in traditional Chinese ceremonies wear elaborate headdresses. (See Wedding Costume) © Royalty-Free/Corbis.

**Top right: Nigerian bride and groom.** Despite the prevalence in many societies to incorporate Western wedding fashion into their marriage ceremonies, many people continue to value national and local traditions. (See Wedding Costume) © Kerstin Geier/Corbis.

**Bottom: Bridal fashions from Godey's Lady's Book, 1868.** The traditional white wedding gown known in the twentieth and twenty-first centuries was less common in the nineteenth century, when women often wore one of their few "good" gowns at their marriage ceremony. These gowns were often black. (See Wedding Costume) © Cynthia Hart Designer/Corbis.







**A Hindu bride and groom.** A Hindu bride and groom are seated for their traditional marriage ceremony. The bride wears an elaborate red *sari*, while the groom is dressed in a white *sherwani*. (See Wedding Costume) © Bob Krist/Corbis.







---

**Kid Creole performs in the musical *Oh! What a Night*, at London's Apollo Theatre.** The zoot suit projected a sophisticated and daring image for its wearer, associated as it was with hipsters, drugs, and sex. (See Zoot Suit) © Robbie Jack/Corbis.

---

