

THE COSMIC WAR

Joseph P. Farrell



**Interplanetary Warfare,
Modern Physics and
Ancient Texts**

Table of Contents

[Dedication](#)

[Title Page](#)

[Copyright Page](#)

[Introduction](#)

[PART ONE: THE BACKGROUND LIGHTNING, STONES, AND WHIRLPOOLS](#)

[Chapter 1. - MODERN ARMAGEDDON, ANCIENT CATASTROPHE: CATASTROPHES CONFRONT](#)

[A. Killer Asteroids and the Exploded Planet Hypothesis](#)

[Chapter 2. - THE THUNDERBOLTS OF THE GODS: PLASMA COSMOLOGY, PLANETARY ...](#)

[A. Plasma Cosmology and Ancient Mythology](#)

[B. Petroglyphs and Anthony Peratt: Plasma Paleophysics](#)

[C. The Divine Weapon](#)

[D. Evidence of Planetary Sized Discharges in the Solar System](#)

[E. Conclusions](#)

[Chapter 3. - THE CATASTROPHE OF CATASTROPHISM](#)

[A. The Catastrophist Problematic](#)

[B. A Return to the Catastrophist Problematic](#)

[Chapter 4. - TIAMAT'S GIANTS AND EARTH'S SKELETONS](#)

[A. Ancient Testimony to the Existence of Giants](#)

B. Strange Legends and Chronological Clues

C. Curious Coincidences and Connections

D. Conclusions

Chapter 5. - PROMETHEUS PULSES THE PULSARS AND GRINDS HAMLET'S MILL: THE ...

A. Hamlet's Mill: Another Mythological Background

B. Tossing Comets at the Sun: McCanney's Version

C. Pulsing the Pulsars: Physicist Paul LaViolette's Promethean Star- and ...

Chapter 6. - CONCLUSIONS TO PART ONE

PART TWO: - THE QUESTIONS: WHO FOUGHT? WHY WERE THEY FIGHTING?
WHO WON? WHO ...

Chapter 7. - REVOLT AND WAR IN THE PANTHEON: A LOT OF WHO, A LITTLE WHY,
SOME ...

A. The Sumerian Version

B. The Egyptian Version

C. The Human Version: the Ullikummi Text

D. When It Happened: Further Indications

Chapter 8. - THE STORY OF THE STONES: A LITTLE MORE WHY

A. The Technological Motivation

B. The Immediate Aftermath: The Technological Inventory

C. The Immediate Legacy: Conclusions

Chapter 9. - THE ENIGMA OF THE TABLETS: WHAT WERE THE "TABLETS
DESTINIES"?

A. The Mythological Components and The Possessors of The Tablets

B. A Summary Thus Far

C. The Mythological Component and the Meaning of “Destinies” in “The Tablets o Destinies”

C. The Quantum Potential or Scalar Physics Basis of the Four Associations of...

Chapter 10. - ME‘S, MER’S, AND MARS: MORE WHO’S AND WHAT’S, AND (AT LA SOME WHERE’S

A. Introductory Pemarks

B. MEs, MERs, and Mars

Chapter 11. - THE GOOD, THE BAD, AND THE NEPHILIM

A. General Observations and Cautionary Notes on Sumerian and Biblical Parallels

B. Sir Laurence Gardner’s Genealogical Tables

C. Ninurta-Nimrod and the Tower of Babel Moment

Chapter 12. - A CATALOGUE OF CLUES: A REVIEW OF THE WAR

A. Primordial Revolts and Wars: Sumer, Edfu, and the Genesis “Gap” Theory

B. More Miscellaneous Clues:

C. Summary: A Catalogue of Clues

PART THREE: - EXTERNAL EVIDENCES: THE EARTH, THE MOON, MARS, A SATURN

Chapter 13. - THE MYSTERIOUS MOON

A. How Did It Get There?

B. Apollo Anomalies

C. LTPs: Lunar Transient Phenomena and the Pre-Apollo Top Secret Telescope Program

D. Shards, Octagons, Craters, and Towers versus “Incessant Meteoric Bombardment”

E. It Rings, Too!

F. Apollo 12 and 13 and Other Moon Miscellanies

Chapter 14. - MARS, AND THE FEAR OF MARS

A. Mars Surface Anomalies

B. The “Fear” of Mars: the Moonlet Phobos and its Monolith

C. The Two Space Programs Hypothesis

Chapter 15. - THE LORD OF THE RINGS OF SATURN

A. Saturn in Greek Mythology: The War With the Titans

B. The Anomalous Orbital Mechanics of Iapetus

C. Anomalous Surface Features of Iapetus

D. Hoagland’s Three Hypotheses For Explaining Iapetus

Chapter 16. - THE ANTIQUITY OF MAN...OR OF WHOMEVER

A. A Brief Review of Cremo and Thompson’s Critique of Evolutionary Theory

B. Anomalous Finds of Great Antiquity Indicating the Existence of Technology

C. Some Radical Speculations Courtesy of the Cooper-Cantwheeler MAJIC-12 Documents

Chapter 17. - SUMMARIES AND FINAL SPECULATIONS

BIBLIOGRAPHY

*For my good friends, the “Extended Inklings”:
Dennis, David, Brad, Susan, Steve, Scott, Bill, Tracy,
Walter, and Kate:*

*All friends who remained true during a storm,
and in fulfillment of discussions held long ago;*

For my good friend Ann, who listened and encouraged;

*And for my mom, Dorothy F. Farrell,
who fought her part in this cosmic war so heroically,
and went to be with the Lord Whose love she so well exemplified
as this book was being finished.*

*Benedicite Deo omnipotente, Patri et Filii et Spiritui Sancto
descendat et maniat super te in aeternum.*

THE COSMIC WAR:
INTERPLANETARY WARFARE, MODERN PHYSICS,
AND ANCIENT TEXTS:
A STUDY IN NON-CATASTROPHIST INTERPRETATIONS
OF ANCIENT LEGENDS

BY

JOSEPH P. FARRELL



Adventures Unlimited Press
Kempton, Illinois

The Cosmic War:

Interplanetary Warfare, Modern Physics, and Ancient Texts (A Study in Non-Catastrophist Interpretations of Ancient Legends)

Copyright 2007 by Joseph P. Farrell

All rights reserved

ISBN: 978-1-931882-75-0

Printed in the United States of America

Published by Adventures Unlimited Press
Kempton, Illinois 60946 USA

10 9 8 7 6 5 4 3 2

Other books by Joseph P. Farrell:

The Giza Death Star

The Giza Death Star Deployed

The Giza Death Star Destroyed

Reich of the Black Sun

SS Brotherhood of the Bell

*“Newton was not the first of the Age of Reason. He was the last of the magicians, the last of the Babylonians and Sumerians, the last great mind which looked out on the visible and intellectual world with the same eyes as those who began to build our intellectual world rather less than 10,000 years ago... Why do I call him a magician? Because he looked on the whole universe and all that is in it **as a riddle**, as a secret which could be read by applying pure thought to certain evidence, certain mystic clues... He believed these clues were to be found partly... in certain papers and traditions handed down by the brethren in an unbroken chain back to the original cryptic revelation in Babylon. ”*

The economist John Maynard Keynes, “Newton *the Man*,” *The Royal Society. Newton Tercentenary Celebrations* (1947), p. 29, cited in Giorgio de Santillana and Hertha Von Dechind, *Hamlet’s Mill: An Essay on Myth and the Frame of Time*, p. 9, emphasis in the original.

INTRODUCTION:

APPROACHES TO A PROBLEM

“This weapon can slay any being within the three worlds, including Indra and Rudra.”

*The Mahabharata*¹

Giants. Nephilim. Annunaki. Colliding planets and the Exploding Planet Hypothesis. Cosmic catastrophe. Comets. Angels. Demons. War in Heaven. The Fall of Lucifer. Wars of the Gods. Ancient epics. Ancient advanced technology. Artificial moons. Miscegenation, genetic engineering, and chimeras. The Face on Mars. Out of place artifacts. And last but surely not least... ..Atlantis.

For most people, these things are unrelated. But for me, the sense has always lingered in the corners of my mind that they were and are somehow all connected, that they are all somehow part of one “something,” components of one all-encompassing *scenario*, a scenario of epic historical and indeed cosmic proportions.

Readers of my *Giza Death Star* trilogy will already be familiar with my weapons hypothesis for the Great Pyramid, and be aware as well of the scenario advanced there that some very ancient and sophisticated weapon of mass destruction *might* have been used to explode the now missing planet(s) of the solar system where the asteroid belt now orbits our sun, grim remnants and reminders of some ancient planet “Krypton.” And most readers of that trilogy will likewise be aware of the fact that I believe the Great Pyramid - or something similar and based upon similar “scalar” physics conceptions - *might* have been the weapon deployed to do it.

But it is to be emphasized that there are massive problems with this all-encompassing and highly speculative scenario, and readers of that trilogy will be aware of some of them. Needless to say, many of these problems are chronological in nature. But there are other equally weighty problems, and I deliberately left these unexplored in the *Giza Death Star* trilogy, leaving them for another book: this one.

My reason for doing so was rather simple: I thought that to burden those already technical books with a lengthy examination of the scenario of an ancient interplanetary war and its ongoing consequences would detract from the main emphasis of those books, since such a scenario, while pertinent to the Weapon Hypothesis of the *Great Pyramid*, is not necessary to it. The *Giza Death Star* books focused on the type of weaponry used to fight the war, and secondarily on the war itself as corroboration that such weaponry once existed. Here the situation is the converse. Here the focus is on the war itself, and secondarily on the type of weaponry used to fight it as corroboration that such cosmic wars in local space were once fought.

But what are those “other problems”?

These may be understood by asking a very simple set of questions: Who fought this alleged war? Why were they fighting? What weapons did they use? What were their effects? Who won? Who lost? Who survived? What was their legacy? And perhaps most importantly, who were the “good guys,” the “bad guys,” and *why* were they “good” or “evil”?

Thus, unlike in my *Giza Death Star* trilogy of books, the emphasis here is on the scenario itself, on the scenario of an ancient interplanetary war in our own solar system and on its prolonged perhaps even contemporary consequences. There are, of course, implications for the hypothesis explored and outlined in the *Giza Death Star* trilogy, and accordingly, some of the material of those books is reprised and expanded upon here, but only insofar as it is necessary to explore the scenario itself. Therefore, the reader should bear in mind throughout the following pages that the two hypotheses

- that of an Ancient Interplanetary War and that of Great Pyramid as a Weapon of Mass Destruction — remain *separate* hypotheses. They dovetail, to be sure, but they do not stand or fall together. Indeed, as the reader will eventually learn in the main body of this work, there is some textual evidence to suggest that whatever weaponry was once associated with Giza may in fact lie in an older stratum beneath the current structures at Giza, and that the present Great Pyramid may be an attempt to reconstruct a much older weapons technology of hegemony. It will also be apparent that *other types* of weaponry than scalar weaponry, or other *modes of deployment* of scalar weaponry — which is my preferred view - may have been used, not only to blow up planets and other celestial bodies, but to leave fantastic searing scars on others, to manipulate weather, and even to manipulate consciousness itself.

Readers of the *Giza Death Star* books will likewise recall that the hypothesis of a Very High Civilization in “extremely ancient times” - named “paleoancient” in the *Giza Death Star* trilogy by my intentionally redundant term — was a broad component of the scenario outlined in those three books. In this book, my occasional use of the term “Atlantis” is to be understood as a *symbol* for that Very High and paleoancient Civilization. Accordingly, I do not intend on entering into lengthy discussions of the location of the celebrated “lost continent” other than in those instances where the topic is germane to the subject under discussion. As has been seen in The *Giza Death Star* trilogy, there are significant reasons to take Plato’s story of a “lost continent” in an “allegorical” sense, in the sense of a “myth” with multiple layers of meaning, from the prosaic literal sense to carefully crafted “paleophysical” ones.

Thus, inevitably, we are led back to the subject of “paleophysics.” The *Giza Death Star* trilogy contained much discussion of the speculative possibility that there once existed a sophisticated “paleophysics” in that paleoancient Very High Civilization, a physics as sophisticated, if not more so, than our own theoretical and practical edifice of quantum mechanics, relativity, string and membrane theory, or alternatively, loop quantum gravity, plasma cosmology, and so on. Such a view had to be advanced if one was to seriously entertain what the ancient texts themselves suggested, namely, that such weapons of mass destruction existed in very ancient times, and that they were associated simultaneously with the destruction of planets on the one hand, and with the capabilities of pyramids in general and the Great Pyramid in particular.

Here the discussion of an ancient paleophysics is renewed and expanded upon. Readers of the first book of that trilogy, *The Giza Death Star*, will find here an expansion on the plasma physics and cosmology of Swedish physicist and Nobel laureate Hannes Alfvén. Additionally, readers will also find additional material on Tom Bearden’s “scalar” or “quantum potential” physics as well,

conceptions which were discussed in *The Giza Death Star Deployed*, *The Giza Death Star Destroyed*, and most recently in my book on the Nazi secret weapon project known as “the Bell”, *The SS Brotherhood of the Bell*.

With all this being said, a further cautionary note is also necessary. In order to tie together all the disparate pieces that I believe may form components of this gigantic scenario of cosmic war and catastrophe, of giants and chimeras, of “gods” and men and Nephilim, it is essential to paint in very broad strokes. While I do entertain discussion of broad chronological and other scientific and archaeological considerations, I do not enter into lengthy examinations of disciplines related to and affected by the Cosmic War hypothesis, such as evolutionary biology, anthropology, or even theology, philosophy, comparative religion, and esoteric or occult history. That such fields are affected by this hypothesis should be obvious. But to discuss each of these implications in detail would not only require several lengthy tomes in their own right, it would also distract attention from the main themes of the scenario as exhibited by the above questions. To ignore them altogether, however, would be equally precarious. Accordingly, I have only sparingly indicated such implications in synoptic form either in the main text or in footnotes, when I think it is appropriate to do so.

Similarly, I do not attempt to reconstruct a whole *detailed* chronology of an alternative “pre-history” of extraterrestrial contact, intervention, war, and so on, as does Zechariah Sitchin in his *Earth Chronicles* series, for a very simple reason. The Cosmic War hypothesis has not hitherto been adequately advanced or explored in its own right, so it would seem best to ascertain its very broad outlines and progression and to put them forward here as a kind of *prima facie* case, and then to work out the detailed chronology at some later point. It may indeed be the case that eventually chronological data, once the frame into which they may be set has been erected, may be easily placed into it. Or it may likewise be the case that such data may completely overturn the framework proposed here. Similarly they may suggest an entirely different framework of the broad progression of the war than the one I suggest here. In any case, the emphasis here is to outline the Cosmic War Hypothesis and its supporting textual, physics, and archaeological evidences in as broad a fashion as possible.

Consequently, the Cosmic War scenario as outlined here remains, like the *Giza Death Star* weapon hypothesis, a *hugely speculative hypothesis*. It is most decidedly not a theory. If it is at all true as a *theory*, then its predictive power must lie in the fact that it will predict the occurrence of distinctly artificial artifacts on nearby planetary bodies in our own solar system, and perhaps of very ancient artificial satellites of planets as well. Additionally, it will “predict” the occurrence of evidence indicating deliberate targeting and destruction of these artifacts and satellites. And finally, it will “predict” the necessity of observers to record this information in the various forms that have come down to us, albeit in garbled form. But history, much less reconstructions of paleoancient history based on mythological texts, is not science for the very obvious reason that its “predictions” are always of an *a posteriori* nature, and thus the cosmic war hypothesis can remain only a hypothesis. Corroboration can only come in the total context of external evidence adduced to support it.

The existence of observers highlights one aspect of the interpretive problems associated with this hypothesis. As will be seen in the main body of this work, human myths and legends abound with details of the “wars of the gods” and the horrendous weapons with which they were fought. As such, one must either (1) opt for the “naturalist” and “materialist” interpretation of such myths along catastrophist lines, or (2) posit the tremendous antiquity of man in a time frame lying quite beyond the

pale of standard cultural history, evolutionary theory, anthropology, and paleontology in order for there to be observers of the events that the texts describe, *or* (3) one must posit a precursor race or species somehow tied to humanity, which bequeathed to mankind its own observations of this war and catastrophe, which then became the nuclei for these human myths and legends. As will be evident in the main body of this book, the myths themselves point to this third alternative as their own favored explanation. But any way one views this problem, one has stepped quite outside the pale of the standard academic models of history, evolution, and anthropology.

It must therefore be frankly and bluntly acknowledged that this work is accordingly *not* one that would be accepted in any academic context. It merely makes a case for looking at these myths as containing real elements of historical and scientific truth in yet another way: that the “wars of the gods” were real, that they engendered planetary destruction and catastrophe here on earth and elsewhere in the solar system, and perhaps even outside it, and that some of the consequences may still be with us in ways that we scarcely imagine.

Similarly, the cosmic war hypothesis is not likely to be met with much enthusiasm among certain strains of revisionists either. At one end are the catastrophists best exemplified in the work of Alan Alford and many others, for whom the whole matrix of conceptions in the complex of symbols used by myths are nothing more than a metaphor for naturally occurring explosions of planets. The cosmic war hypothesis is, needless to say, antithetical to this whole enterprise. At the other end of the spectrum is the disturbing tendency in so much alternative literature to paint this putative paleophysical past in idealistic terms, as a golden age, a warm and fuzzy “Disneyworld” of “jonquils and daisies” devoid of nasty bad things like interplanetary wars and their associated technologies. However, such an attitude simply flies in the face of the overwhelming preponderance of “cosmic war” traditions from all over the globe. And this brings us to the nature of the evidence itself.

Careful consideration of the questions outlined above, and of the parameters of the “interplanetary war scenario” itself, will also reveal the *types of evidence* to be considered in this work: (1) physics, (2) the material evidences of anomalous artifacts, (3) evidences and mechanisms of planetary destruction, (4) evidences of possible deliberate targeting and destruction, and finally, and by no means the least important, (5) textual and “legendary” evidence from texts, oral myths and traditions, and physical monuments and ancient glyphs. “Text” in other words is understood in this book in the broadest sense, as being inclusive of all these things.

Finally, a word about how the term “war” is to be understood in this work. When one normally thinks about this word “war”, one conjures images of trebuchets, tanks, and triremes, of ballistas and bombardiers, of cavalry and cannon, of ships-of-the-line and steel-clad armored dreadnoughts, of armies, fleets, and more recently, vast aerial armadas and mushroom clouds, particle beams, high energy lasers and grasers,² all clashing and often annihilating their enemies. In short, one naturally imagines all the associated technologies of war. It is no different, as we shall see, with the ancient texts. There too, the ancient texts conjure images of generals, admirals, political leaders, of heroic deeds and despicable acts, of the suffering of the innocent, wanton destruction of property, and most importantly, a technology capable of the most contemporary interpretation of extreme sophistication. The ancient texts, as does recent history, conjure images of city-wide devastation, and of the as yet (and hopefully) only theoretical regional destruction that might follow even the most limited nuclear and thermonuclear exchange. As will be seen in the remainder of this work, I certainly believe the cosmic war scenario to include these aspects of “war.”

But there are also more subtle forms of warfare, such as when a “vanquished” party goes underground to wage a “guerilla war,” complete with secret cells, passwords, means of recruitment, propaganda and psychological warfare and all that these things entail. These, too, are included in my use of the term “war”. Consequently, I mean the term “cosmic war” in a truly “cosmic” sense inclusive of its *spiritual aspects and ongoing nature*, for as any careful consideration of the texts will demonstrate, this war possessed the characteristics of an ongoing guerilla that from time to time erupted into wholesale open hostilities. And as the texts also indicate, some of the “people” who fought this war, or their descendents, may still be around. In this respect, “war,” also includes the underlying concept of the civilization fighting it. So in examining the cosmic war hypothesis, we are also examining the underlying civilization and its mores, and this fact may indeed be why the hypothesis has never been adequately explored by the two strains of revisionists previously referred to, for it thrusts the philosophical question of theodicy to the fore, a question totally avoided by catastrophism which is but a variant of materialism, and by the golden age warm fuzzies and Disneyworld “jonquils and daisies” approach, which is but a variant of wishful thinking.

In fact, as I suggested in my book *The GiZa Death Star Destroyed*, the paleoancient war was not only the fertile seeding ground for the many versions of catastrophism (including that version which views it as a regular cycle), but also the soil that germinated and nurtured the ancient mystery cults and eventually the secret societies and priesthoods that succeeded them. The “cosmic war,” as many religious traditions - especially the Judeo-Christian - have alluded, is an ongoing one. But as will become equally clear, that latter tradition may itself have erred somewhat by viewing that “warfare” as an exclusively “spiritual” or even “personal” one, without considering the possibility that it was also a very real war in a very real cosmic sense fought in very real places by very real persons who possessed very real *technologies*. It is, after all, only our modern outlook that opposes the spiritual and the physical, but such an opposition would have been foreign to the ancient frame of mind, and would seem to be at complete variance with the broad sense of the Christian tradition’s own legacy of sacramentalism.

One may perhaps now appreciate the magnitude of the task presently before us, for not only are so many disparate themes and subjects - as outlined in the opening paragraph - possible components of this scenario, but many discrete types of evidence must be adduced and synthesized in a convincing fashion to support it. Consequently, on any number of levels the scenario may be rightly and strongly challenged, from the weight accorded to different types of evidence, to the interpretation put upon them, to the broad picture that emerges, to the chronological - and more importantly spiritual and theological - questions it raises.

For these reasons it must be reiterated - here, now, and in the strongest possible fashion - that the highly speculative and indeed radical scenario outlined here is *only* hypothetical, dwelling in that foggy gray area between ancient science fiction, and the disturbing question “Yes, but what if it were true, even if only in parts?”

When I first began this line of research and writing a few years ago with my book, *The GiZa Death Star*, I included as an epigraph to the Preface of that book a statement allegedly made by the physicist Nils Bohr to his colleague Werner Heisenberg, one of the main architects of modern quantum mechanical theory, and discoverer of the Uncertainty Principle which is named after him. It seems fitting to close this preface with that same remark, and to suspend it over the totality of this work as a reminder of its radical and speculative nature: “Sir, we’re all agreed your theory is crazy. The

question that divides us is, whether it is crazy enough.”[12](#)

Joseph P. Farrell
2007

PART ONE: THE BACKGROUND LIGHTNING, STONES, AND WHIRLPOOLS

*“I suggest that Van Flandern’s Exploded Planet Hypothesis makes sense only if one is willing to entertain a nonnatural explanation. Of course, this is heretical on several levels, as the explanation must somehow encompass the presence of potential artifacts on Mars as well as a presumed high-tech culture on Mars’ erstwhile parent. “Strangely, the revelatory climax from Eando Binder’s **Puzzle of the Space Pyramids** comes to mind. In Binder’s novel, the asteroid belt was formed by a focused gravity assault that harnessed the energy of the entire solar system. The pyramids of the title were essentially gravity generators used to manipulate space-time.”*

Mac Tonnes,

After the Martian Apocalypse: Extraterrestrial Artifacts and the Case for Mars Exploration, p. 47.

“Reality will transcend allegory every time.”

Paul Krassner, from the Foreword to Peter Levenda’s
Sinister Forces: A Grimoire of American Political Wlitchcraft,
Book Three: The Manson Secret.

1.

MODERN ARMAGEDDON, ANCIENT CATASTROPHE: CATASTROPHE CONFRONTS TECHNOLOGY, AND LOSES

“The strategy that Werner Von Braun taught me was that first the Russians are going to be considered the enemy... Then terrorists would be identified, and that was soon to follow... Then we were going to identify third-world country ‘crazies.’ We now call them Nations of Concern. But he said that would be the third enemy against whom we would build space-based weapons. The next enemy was asteroids. Now, at this point he kind of chuckled the first time he said it. Asteroids — against asteroids we are going to build space-based weapons. And the funniest one of all was what he called aliens, extraterrestrials. ”

*Dr. Carol Rosin.*³

The war rooms of the world’s major powers are busy with gloomy activity, playing out games with think tank precision and dedication, toying inconsistently with planet-busting technologies in order to avert a global Armageddon and save the world.

In Moscow, in hardened bunkers far below the Kremlin, Russian President Valerie Pischoff and his senior defense command heatedly discuss their options. Some urge that they deploy their gigantic region-busting hydrogen bombs *en masse* and, in a sudden, decisive, and massive strike, blow the enemy into a thousand pieces. Others weigh in against such a drastic move, reminding the President that the danger of a radioactive rain from such a move would be almost as dangerous as the threat itself.

In Beijing, in similar bunkers, the mandarins of China’s burgeoning defense establishment argue with China’s premier, Dang Mai Luk, for a more subtle course. Perhaps it would be just possible, they argue, to divert the attack with just the right, precisely placed counterstrike to give it a slight “push” in the right direction, and thus avert the catastrophe. It is a classical martial arts approach, one steeped in the Oriental tradition of warfare: the use of an enemy’s strength and mass against him.

In Europe, defense ministers and heads of governments hastily summoned to Berlin by German Federal Chancellor Angeline Merkwurdigliebe urge an international diplomatic effort in the United Nations Security Council, warning of dire political consequences if any of the world’s powers should decide to deal with the rogue attack unilaterally in an ill-conceived and hasty military response, while outside, Neo-Fascist skinhead groups protest, urging that Europe’s powers flex their considerable military and technological muscles and take out the rogue, demonstrating to a grateful world that Europe was still a “player.” Inside, some delegates, acutely aware of the demonstrations outside, call for a technologically sophisticated variation on the subtle Oriental approach: a “nudge,” a “warning shot across the bows,” not with the sledge-hammer thermonuclear approach of the Russians, nor the scaled-down nuclear nudge of the Chinese, but with space-based lasers and other

exotic directed energy weapons. Leading the charge for this approach are the four major European powers, France, Great Britain, Germany, and Italy. The rest of the European nations' delegates fidget and squirm nervously in their chairs, but ultimately acquiesce, for the reality of European geopolitics has not changed since the Franco-Prussian War; those four nations still possessed the bulk of Europe's financial, technological, and military clout. Everyone else was, well, just along for the ride.

In the United States, an ad hoc presidential "blue ribbon panel" has been quickly, if not quietly, assembled on the orders of President Jordan Walter Schrub. The panel consists of the National Security Council, Pentagon generals and admirals, various scientists, engineers, economists, and media experts. Typically, the panel weighs all the alternatives being discussed in the other capitals, recommends all of them and none of them at the same time, urges "cautious but decisive action," calling upon the State Department to mitigate the political fallout of what will be perceived as "American unilateralism." The Congressional opposition meanwhile calls for hearings on why nothing was done about the rogue threat long before, since the United States government gave every indication of having known about it for several years, and of having done nothing to avert it. And in typical fashion, the Congressional opposition's more radical members produce their own retired military and scientific experts who argue that the threat is no threat at all, that it will break up of its own internal stresses long before it can do any serious damage. Even more radical elements in Internet chat rooms and discussion groups go so far as to suggest that the government had engineered the threat for its own benefit, or at the minimum was capitalizing on a heaven sent opportunity to expand its power. But the opposition is clear about one thing: no military action should be taken against the threat, since that could be used as an excuse to militarize outer space.

And there is a final player, a most unexpected one. In Sao Paulo, Brazil, a small and elite cadre of generals, scientists, and cabinet ministers gather in the president's study over cognac and cigars, casually recommending that the Brazilian President offer to the concerned parties Brazil's own quite unique technology for dealing with the threat, a technology that has no need of the "gentle" thermonuclear nudge of massed hydrogen bombs nor of the more sophisticated obliteration of lasers, particle accelerators, or phased plasma cannon. The discussion is relaxed and cordial, having none of the sense of urgent gloom that pervading the discussions in other world capitals.

"The earth," says one paleontologist in perfect and elegant Portuguese, "faced this threat before, and all life was nearly exterminated. We are fairly certain that the dinosaurs, at least, owe their extinction to it. But now we can do something about it, and need not face another such catastrophe. Mr. President, I urge you to deploy the weapon, to make it available to the world, because we can be quite certain that neither the Russians nor the Germans nor the Japanese will reveal their own possession of the weapon unless they absolutely have to, and even then, we cannot risk the chance that they would not do so, and we cannot allow the Russians, Chinese, or Americans to make a thermonuclear strike." The Brazilian President nods in agreement, savoring his cigar.

The "rogue threat" is a killer asteroid, larger than one kilometer in diameter, and it is on a definite collision course with the planet Earth in approximately nine months' time. When it collides, it will release the energy of 10,000 megatons of TNT, one hundred times the magnitude of the largest thermonuclear bomb mankind has ever tested. It will throw into the atmosphere a choking cloud of dust, alter the earth's climate in unknown, permanent and catastrophic ways, and possibly eliminate all life from the face of the earth.

A. Killer Asteroids and the Exploded Planet Hypothesis

While the scenario outlined above may seem to be the farthest thing from the subject of an ancient, lost, technologically advanced civilization, much less an interplanetary cosmic war, it affords perhaps the best entry into a discussion of these subjects, for the scenario of a modern-day killer asteroid strike is based on evidence of similar primordial strikes on the earth, one of which was indeed believed to have been the cause of the extinction of the dinosaurs, and the rise of mammalian life ca. 65 million years ago. Such a scenario has become a major concern of the militaries of the world's technologically sophisticated powers. Yet another "minor" event ca. 3.2 million years ago coincides, according to the standard theory, with the rise of the earliest hominid ancestors of mankind. These two dates, as will be seen, will become very crucial in the development of the Exploded Planet Hypothesis, and thus in the development of the Cosmic War Hypothesis.

In the last two books of my *Giza Death Star* trilogy, *The Giza Death Star Deployed* and *The Giza Death Star Destroyed*, I referred to the scenario of an exploding planet in our solar system having been the victim of deliberate destruction utilizing the enormous power of "scalar" or "quantum potential" weaponry. In doing so, I outlined the Exploded Planet Hypothesis of Dr. Tom Van Flandern. Since our focus is now on the scenario an ancient interplanetary war itself, his hypothesis must be outlined more thoroughly, in order to correct the inevitable inaccuracies that arise in presenting any short summary, as well as to understand his hypothesis and its implications for such a cosmic war scenario more completely.

1. The History of the Exploded Planet Hypothesis

The history of the Exploded Planet Hypothesis actually begins in the eighteenth century with an unusual astronomical law known as Bode's law, or the Titius-Bode law, named for the German astronomers Johann Daniel Titius and Johann Ehlert Bode who first proposed it. Basically, both astronomers noticed that the distance of the planets' orbits from the Sun fell into a neat harmonic mathematical progression. The progression may be obtained by starting with the simple numerical sequence 0 1 2 4 8 16 32 128 256. Multiply this by 3 to get 0 3 12 24 48 96 192 384 768. Add 4 to this to obtain 4 7 10 16 28 52 100 196 388 772. Setting the earth's distance at "10" gives Mercury at 4, Venus at 7.2, Mars at 15.2, and Jupiter at 52.0, which is approximately in line with the progression and with their actual orbits. But astronomers noticed that, by the prediction of the law, there should be a planet at the number 24 in the progression, but there was none. The search was quickly on for the missing planet. The modern exponent of the Exploded Planet Hypothesis, astronomer Dr. Tom Van Flandern, puts this history this way in his work *Dark Matter, Missing Planets, and New Comets*:

The astronomer Daniel Titius notices a curious fact about the spacing of the planets: each of the six known planets is roughly twice the distance of the previous one from the Sun, with only one exception, a gap between Mars and Jupiter. The gap is just the right size to hold one additional planet. Astronomer Johann Bode publicizes the curious fact in 1778 as a "law." Not too much is thought of it until 1781, when William Herschel discovers the seventh planet, Uranus, and it is found to be in excellent agreement with Bode's law. This draws attention to the gap and the missing planet predicted by the law.⁴

The problem was quickly resolved, for on January 1, 1801 the Italian astronomer Giuseppe Piazzi "discovers the missing planet while observing."⁵ The new planet orbits the Sun exactly where the Titius-Bode law predicted it should. It was given the name Ceres.

But there was a further problem, and it was a significant one. The new "planet" was "incredibly tiny compared to the other planets, not even big enough to make a good-sized moon."⁶ The problem was quickly magnified when later that year yet another miniature "planet" was discovered in roughly the same orbital distance from the sun, and given the name Pallas.⁷ Now there was not one, but two miniature planetoids, where there should only have been one large planet according to the Titius-Bode law, and both of these "planets" were not even as large as moons.

At this point, the German astronomer Heinrich Olbers proposed a bold new theory to explain the phenomenon: "a larger planet had exploded!"⁸ Thus, Olbers was able to predict that more such miniature "planets" would be discovered in more or less the same orbit, and "that they would vary in brightness as they spun, because fragments should be irregular in shape."⁹ The Exploded Planet Hypothesis was then expanded by the French astronomer Louis Lagrange in 1814 to explain the origin, and the unusual and extremely elongated orbits, of comets, since these would be "natural byproducts of an explosion."¹⁰

However, unfortunately for Olbers' and Lagrange's explosion theory, the well known and highly

respected astronomer Laplace weighed in with “several telling arguments” and discounted the theory.

The attack of this prestigious astronomer cast the planetary explosion theory into disfavor for most of the next 175 years. Various new evidence and arguments, pro and con, appeared in the interim, but the astronomers as a whole were now committed to more conventional explanations. Even the appearance of a definitive treatise on meteorites by Brown and Patterson in 1948, in which they concluded there was irrefutable evidence that meteorites were once an integral part of a larger planet, did not sway the bulk of the astronomers.... who generally believed that the thousands of known minor planets orbiting between Mars and Jupiter were the remains of a planet which had never been formed, rather than one which had broken up.¹¹

Then, in 1972, the Exploding Planet Hypothesis was given a first nudge toward rebirth when the Canadian astronomer Michael Ovenden resurrected and revised Bode’s Law.

Ovenden derived a much more elaborate mathematical formula than the original Titius-Bode law, a new formula that not only “predicted the spacing of the planets” but also “their major satellites.”¹² But that was not all.

(He) also came to the conclusion that a planet was missing from the area where the minor planets orbited. But Ovenden predicted that it must have been a giant planet the size of Saturn, and much larger than all the other planets put together. This was an important possibility not previously considered. *It meant that the event which destroyed the planet must have involved enormous energy.* It also meant that much of the debris had been blasted out of the solar system completely.¹³

The enormous energy required for a planet to explode plus a plausible model for why they should do so is one of the most significant difficulties in the Exploded Planet Hypothesis, as we shall see.

2. *The Explanatory and Predictive Power of the Exploded Planet Hypothesis*

a. Asteroids and Meteorites

However, notwithstanding the problem of the enormous energy required for a planet to blow up, plus the additional problem of a plausible physical model by which such an event may be explained by natural causes, the Exploded Planet Hypothesis *does* possess enormous explanatory and predictive power, an explanatory and predictive power that far exceeds those of the favored theories within contemporary astronomy.

For example, the hypothesis is more than an adequate explanation not only for the occurrence of meteorites, but for some of their more unusual features:

Some of them show evidence of rapid melting a long time ago, as if they were affected by an immense heat blast. A few show evidence of shock, others are badly charred. Some meteorites display evidence that they formed in a high-temperature or high-pressure environment, as in the interior of a large planet; for example, tiny diamonds have occasionally been reported in meteorites. And there is specific evidence of exposure to an event of enormous energy, which conventional theory supposes to have been a nearby supernova.¹⁴

Moreover, those bodies without an atmosphere in the “outer solar system are coated with an extremely dark material. This may be the carbonaceous residue from the blast.”¹⁵ Additionally, some of the moons of Neptune lie within the Roche limit “*where tidal stresses would tear apart a forming body.*” Remember this point about tidal stresses, for it will become crucially important in a moment. This means simply that these “moonlets” simply could not have been formed near their current orbits, but were the result of capture, and the “exploded planet hypothesis provides a natural origin” for this phenomenon.¹⁶

And as for the presence of diamonds in some meteorites, this is not the only unusual feature of meteorites that the hypothesis helps to explain. Their presence in fact led some astronomers to propose novel and heretofore unknown mechanisms for their formation from “space collisions” or “during atmospheric entry or by Earth-impact shock” without the need for the sudden shock and high-pressure high-heat environment of a planetary explosion. But there exists one unshocked meteorite, named Abee, where none of these suggestions “can be operative.” Moreover, there are diamonds found at the K/T geological boundary on earth (ca. 65,000,000 years ago) that “are confirmed to be of extraterrestrial origin” and which therefore cannot be generated by earth impact.¹⁷

Yet another unusual feature is explained by the hypothesis. Van Flandern puts it this way:

Asteroids exhibit “explosion signatures” in the distribution of their orbital elements. These relationships between the orbital elements “a” (semi-major axis), “e” (eccentricity), and “I”

(inclination) were first found among fragments from artificial satellites of the Earth which exploded in orbit, and then were found to hold for the asteroid belt as well.¹⁸

The theory explains why some of these asteroids, which appear to have their own even smaller satellites, even *have* such satellites at all, for “tidal forces and collisions should have eliminated most minor planet satellites in far less than the age of the solar system, but not in a time as short as a few million years.”¹⁹ In other words, the event that led to the formation of the asteroid belt, in which one finds asteroids with their own tiny satellites, must have occurred in a relatively “recent” time as far as astronomical times go, in the last few million years. As we shall soon discover, the timing of this event will assume enormous importance both for the development of the Exploded Planet, and for the Cosmic War, Hypothesis.

b. Comets

While the Exploded Planet Hypothesis was first formulated by Olbers to explain the existence of asteroids, Lagrange soon found an even more interesting aspect of its explanatory power: it adequately accounted not only for the existence of the elongated orbits of comets and their large orbital periods, but it accounted adequately for their origin. It also accounted for another odd feature of comets, or rather, for an odd feature that has never been observed about comets. If one assumes, as contemporary astronomical theory does, that most comets originate from a point beyond the planetary solar system, that is, from a point beyond Pluto, then one should expect that there is a class of comet, on hyperbolic orbits, that will take them into the solar system once, then back out of it, once, never to return. But no such orbits have ever been observed for comets.²⁰

This raises the issue of the current standard theory for the origin of comets, the so-called “Oort cloud” and its corollaries. The Oort cloud is contemporary astronomy’s accepted standard model for the origin of comets. This “cloud” is thought to be a region of “space debris” far beyond the orbit of Pluto, at the very fringes of the solar system. At such distances, the debris is thought to be able to react to the gravitation of passing stars, which then more or less “kick” it into the wild orbits we observe as comets. But this theory should mean that some comets are “kicked” into the hyperbolic orbits already described, and these should “arrive at the rate of at least a few per century if comets have been interacting with passing stars for billions of years.”²¹ But comets, as we know, *return*. They may be recurrent pests, visiting every few decades or so, or the occasional visitor stopping by once every few hundreds, thousands, or even millions of years. But the point is, they *return*, and if they return, then there is a regularity and pattern to their orbits that is difficult for the Oort Cloud model to predict. It is here that the scientific priesthood stepped in with a quick patch to fix the leaky structure:

To minimize these difficulties it is now imagined that the Oort cloud comets come from a hypothetical “inner core” between the planetary region²² and the Oort cloud. There is no observational evidence for such a region - it is simply a theoretical construct. Then the inner core is fed by a hypothesized “Kuiper belt” of comets of nearly circular orbits near the plane of

the other planets, beginning just outside the orbit of Neptune, which is supposed to have been left over from the primeval solar nebula. Again, there is no observational evidence for this region either, despite many intensive searches...²³

Thus, Van Flandern proposed a revival and revision of the Exploded Planet Hypothesis in 1978 since the origin of comets in the explosion of a planet would explain the observed characteristics of their orbits “in an a priori way.” Moreover, the new theory proposed that the exploded planet, which was the origin of comets, existed in a parent body “in or near the present location of the asteroid belt” and that this event had necessarily occurred “in the relatively recent past.”²⁴

Such a theory makes far more sense than an imaginary theoretical construct like the Oort Cloud, with its recent “fix”, the Kuiper Belt, for yet another simple reason. In order for the Oort cloud theory to work, the “debris cloud” which comprises it has “to be immense in order to provide the few comets we observe, because the chances are so small of any one comet being perturbed into observable range.”²⁵

In summary, the hypothesis that comets originated in a breakup event only a few million years ago in the inner solar system makes a number of very specific predictions: that there will exist a category of first return (“new”) comets; that these will have huge aphelion distances with intrinsically very little scatter; that they will come from preferred directions on the celestial sphere with a specific percentage bias; that the number of orbits will diminish as one looks closer to the Sun; that the distances and directions of approach will be correlated; and several other characteristics.²⁶

Thus,

The exploded planet theory is the only dynamically viable alternative to the Oort cloud. The latter requires the existence of an implausible cloud of more than a trillion comets orbiting the Sun at distances 1000 times that of Pluto, so remote that passing stars would frequently pass through it.²⁷

The failure of this standard Oort cloud theory to detect any source for a re-supply of the Oort cloud “from a hypothetical inner ‘Kuiper Belt’ means that Oort cloud comets should have long since been depleted by passing stars, galactic tides, and passage of the Sun...unless comets originated quite recently.”²⁸

c. Other Phenomena Explained by the Exploding Planet Hypothesis

Other strange solar system phenomena are explained by the hypothesis, not the least of which is the strange hemispheric discrepancy observed on the Earth’s satellite, the Moon, and its even stranger regions of anomalous “denser mass,” the well-known “mascons,” for

The Moon's hemispheric asymmetry could have been caused by the blast. It would then be no coincidence that the hemisphere with all the dark "seas" faces the Earth, since the extra mass accreted by the Moon (which shows up as "mascons" — mass concentrations under the lunar "seas", which are actually lava flows) would have caused the Moon to change its orientation until its "heavy side" faced "down".²⁹

Yet another odd feature explained by the hypothesis is that the orbit of Mars' moon Phobos will decay into Mars' atmosphere "in about 30-40 million years," a fact which is explainable if Phobos originated about "3,200,000 years ago."³⁰ Note now that one has the first indicator of a more or less exact time that the explosion of the missing planet occurred. This will become quite the crucial point as we proceed.

A loose corroboration of this timing is provided by the fact that the ratio of hydrogen to deuterium on Mars indicates that the Red Planet's "formerly abundant flowing water has been lost in just the last 10^5 to 10^7 years,"³¹ that is, Mars lost its water between 100,000 and 10,000,000 years ago. This would mean that during the 3,200,000 years event, Mars may still have been a water-bearing planet. Yet another loose corroboration of the 3,200,000 years benchmark is provided by Jupiter and its massive gravity itself. While Jupiter's mass "is insufficient to have interfered with the formation of a normal planet" in the asteroid belt, it is sufficient to have "swept up almost all the mass from the exploded planet that did not escape the solar system." Even its excess heat "may be an indication of relatively recent mass accretion by the planet."³²

d. The Timing of the Event: 3,200,000 Years Ago

In its original version, Van Flandern was led by the preponderance of the evidence, especially the mathematical, statistical evidence based on cometary orbits, to suggest that the explosion of the missing planet occurred some 3,200,000 years ago. He describes what then occurred in very suggestive terms:

Let us go back in time three million years. On Earth, the dinosaurs became extinct much earlier, land animals gave rise to the primates, *and the earliest ancestors of man have just appeared on the scene*. Elsewhere in the solar system everything is as we know it in the twentieth century, with one major exception. There is one additional planet between Mars and Jupiter, larger than any of the others except Jupiter itself. From Earth the extra planet is bright enough to be seen in the daytime, and dominates the night sky with its brilliance.

Suddenly, it explodes! Like a nova in our own solar system, it brightens until it outshines the Sun itself. Solid, liquid, and gaseous debris is hurled into space at high velocities in all directions. Nonetheless, it takes months for the leading edge of the blast to reach the Earth. What a sight it would have been for early man to see! The sky ablaze with meteors night and day unceasingly for months.³³

Such an event, and its effect on the Earth and any observers on it, would clearly have been very dramatic, as Van Flandern suggests. More importantly, it would have had an inevitable effect on the Earth's geology and climate. Indeed, it is precisely around the same time frame, approximately 3,000,000 years ago, that the equatorial-like climatic conditions which are believed to have prevailed on the Earth up until that time, suddenly changed to "a succession of ice ages over the past 3,000,000 years or so."³⁴ While the mechanism for such a sudden change is not known in conventional theories, a "massive influx of water vapor from the planetary explosion may have been responsible."³⁵ Indeed, to the influx of water vapor one would also have to add an influx of "debris" and "dust" that would have had atmospheric and climate-altering potential.

So what do we know about the missing planet? "Ovenden's dynamical calculations indicate that a massive planet, perhaps Saturn-sized, is missing from the gap between Mars and Jupiter, where the main belt of asteroids is found."³⁶ Since comets and asteroids also appear to be about 20% water,³⁷ we can now draw some conclusions:

1. The planet was large, approximately the same mass as Saturn.
2. The planet was *solid*, for diamond bearing carbonaceous asteroids appear as the debris of its explosion.
3. The planet was very likely a water-bearing planet, since Mars, exhibits definite and distinct evidence of sudden, massive flooding across its entire southern hemisphere.

We may now speculate a bit further. If this planet was home to intelligent human-like life, it would seem to be likely that such life would have been of much larger size, with more massive skeletal structure and musculature to accommodate the higher gravity. In short, such creatures would be, by modern human standards, giants. Thus, the existence of any remains of such creatures might be explainable as having an ultimate origin on such a world, and would therefore constitute corroborative evidence — of a very loose sort, to be sure - of the existence of such a planet.

For the moment, however, let us return to Van Flandern's hypothesis, and note its problems, problems he himself ran into as he elaborated the theory.

3. Problems of the Original Exploded Planet Hypothesis and the Revised Hypothesis

a. Astronomy versus Geology: The Chronological Problem

As noted, in its first formulation, Van Flandern proposed that the explosion of the planet occurred some 3,200,000 years ago. But this highlights a clash of sciences, in this case, astronomy and geology.

(1) Van Flandern's Initial Reconciliation

Van Flandern first observed this problem and noted its difficulties in the following fashion:

Such a major explosion should leave evidence all over the solar system, and apparently has. Yet in the geological record on Earth, there is little to support the hypothesis of a major explosion specifically at 3.2 million years ago. There is evidence for the onset of a series of ice ages about then, after a long span of tropical climate. And the origin of man dates to around then. But one would have expected a global layer of carbon deposits, enrichment in the element iridium, shocked quartz from impacts, multiple impact craters, micro-tektites and micro-diamond formation, enhanced volcanism, atmospheric and ocean changes, a single global fire, mass extinction of species, and many other dramatic changes. Such things are seen in several places in the geological record, but not near 3 million years ago according to the presently adopted geochronology. Strikingly, all those features are seen together at the Cretaceous-Tertiary (K/T) boundary, dated at 65 million years ago, when the dinosaurs and many other species became extinct. *The expectations from the astronomical evidence and the realization in the geophysical evidence appear to be identical except for dating.* [38](#)

Astronomy and geology, in other words, agreed on the *event*, but were in profound disagreement as regards its *timing*.

Van Flandern's initial reconciliation of this dilemma is worth citing at length:

Occam's Razor virtually demands that the astronomical and geological events be reconciled. This leads naturally to the conjecture that the geological time scale (based as it is on radiometric dating, stratigraphy, magnetic reversals, sea-floor spreading, and a few other techniques) may not be interpreted correctly. For example, among the possibilities for such a drastic rewriting of the geological record, the rocks that are radiometrically dated to 65 million years ago may indeed have formed at that epoch, but were perhaps only deposited into the geological layers where we find them about 3 million years ago. *Or radiation from the explosion may have*

falsified the radiometric ages. To pursue these conjectures, a geologist would have to consider what effect an energetic, irradiating event like the planetary explosion would have had on each type of geological clock, and then determine if there is an alternative way of synchronizing the various geological clocks. *Certain existing clues, such as the mystery of the polonium halos in granitic rocks (which shouldn't exist if the accepted chronology is correct), may be indicating that the accepted chronology does indeed need extensive modification.* ³⁹

That is, in Van Flandern's initial confrontation of the astronomical versus geological chronologies, geology had to be modified on the basis of the astronomical theory, which in order to account for the discrepancy posited significant modifications of radiometric dating effects as consequences of the event itself.

(2) The Failure of Van Flandern's Initial Chronological Reconciliation

Van Flandern was led to reformulate his hypothesis in order to account for this chronological discrepancy, as well as to account for new classes of evidence not adequately accounted for in the original theory:

Numerous unusual geological anomalies associated with the K/T boundary layers on Earth closely match the predicted consequences of an exploded planet, especially their global nature. But the geological dating of that layer, (to approximately 65 million years ago)⁴⁰ and an even more devastating event recorded in geological layers at (250 million years ago), do not match the well-established dating of the most recent solar system explosion event at 3.2 (million years ago). Some meteorites came from a chemically differentiated parent body, while others came from an undifferentiated parent. New findings in the outer solar system strongly hint at a second asteroid belt beyond Neptune. Even main-belt asteroids come in two chemically distinct types. And cosmic ray exposure ages of meteorites have several age clusterings. *These and other data, while still favoring an exploded planet origin over the standard model, are inconsistent with a single such event. We here introduce the multiple exploded planet hypothesis (MEPH), and conclude that the most recent and best-defined astronomical event serving as the origin of all comets at 3.2 (million years ago) was the explosion of a modest, probably moon-sized, body.* Comets originating from explosions cannot survive in orbits that bring them within observable ranges for longer than 10 million years, so earlier explosions, even of major bodies, show only asteroidal, meteoric, and geological evidence.⁴¹

Thus, as far as the timing of the event was concerned, the conflict between the astronomical and geological models was simply too great to be resolved or reconciled along the lines that he initially suggested, as he himself acknowledges:

The geological dating of the K/T event at (65 million years ago) by radiometry is confirmed by multiple independent methods yielding similar dates, which makes calibration errors in using the method unlikely. I considered that radiation from the explosion might have falsified the

radiometric clocks in rocks used for this dating. But it is difficult to invent a realistic scenario in which the stratigraphic layers on Earth both below and above the K/T boundary layer, typically 5 km below the Earth's present surface, could still show a continuous pattern of radiometric ages from zero near the present surface to hundreds of millions of years at depths greater than the K/T boundary. So I then considered possibility that all rocks suitable for radiometric dating originated on the planet that exploded, and simply mixed with a large amount of inert terrestrial matter on impact. However, the predicted discontinuity of radiometric dates at the K/T boundary under that scenario is not observed.⁴²

Thus, for this and other reasons, Van Flandern was led to posit *more than one planetary explosion*, at different dates, to explain the geological record of the Earth, as well as to square the hypothesis with other types of evidence.

(a) A Speculative Reconciliation of the 3,200,000 BC Explosion with the K/T Geological Boundary Layer Data

By now it is apparent that Van Flandern initially favored a planetary explosion around a mere 3,200,000 years ago, since this was where the preponderance of the astronomical and mathematical data led him, and yet, this could not be conveniently reconciled with the geological data on the basis of the models he initially proposed.

But in my opinion, he may have abandoned the 3.2 million years ago date as the main event a little too quickly, for another mechanism would seem to be available to explain the relative absence of confirming geological debris on the Earth for such an explosion at that date. It is possible that this explosion took place when the Earth was at or near its farthest point from the exploding planet. In such a case, it is conceivable that the shock wave and debris from the explosion of the planet would have been considerably dissipated by the time it reached the earth, nevertheless leaving the event *observable* from the Earth. On this model, there would be no need to explain the K/T geological boundary, or rather, the absence of a similar boundary at 3,200,000 years ago. One must look, then, for other types of corroboration of the 3,200,000 years event. Nonetheless, evidence for a planetary explosion at the time of the K/T boundary at 65,000,000 years ago remained.

b. Two Classes of Asteroids and a New Asteroid Belt?

One type of evidence unaccounted for in the original hypothesis but explained by the revised version are the two types of asteroid classes, the "C" class, composed mostly carbonaceous material, and the "S" class, composed mostly of silicate material. "The C-type asteroids are found predominantly in the middle and outer main belt, whereas the S-types are concentrated toward the inner main belt. This is one of a few lines of evidence... that suggests two different origin events for the main belt."⁴³ Moreover, a recent discovery of another belt of asteroid-like objects beyond

Neptune may indicate yet another distinct planetary event as their origin.⁴⁴

(1) And Multiple “Events”

Because of the existence of these two very different and chemically distinct classes of asteroids, and the possible existence of a second asteroid belt beyond Neptune,

I now consider that there may have been at least two bodies orbiting between Mars and Jupiter (e.g. Planet V and Planet K...) that exploded at different epochs. Indeed, if it turns out that the trans-Neptune belt is a third example of an exploded body in our solar system, *it might even be suggested that explosion is a not-infrequent end state for masses of lunar or planetary dimensions everywhere in our galaxy.*⁴⁵

Note now that what began as an observed problem in the Titius-Bode law, that of a missing planet, has now become a problem of a very different sort, that of *two* planets in more or less the same orbit, where the law predicts one.⁴⁶

(2) The Revised Scenario Outlined

Van Flandern summarizes the new revised Multiple Exploded Planet Hypothesis this way:

I thus tentatively associate the earlier, larger mass-extinction event at (250 million years ago) with the explosion of Planet K in the main asteroid belt, with iron meteorites (because of their long cosmic ray exposure ages), and with most cataloged main-belt asteroids. This event occurred so long ago that it gives Mars enough time to clear out most Mars-crossing asteroids from the main belt - thereby neatly explaining the one other line of evidence that did not fit the original hypothesis....

And I tentatively associate the smaller event at (65 million years ago) with the explosion of Planet V in the inner asteroid belt, with achondritic and stoney-iron meteorites (which have younger exposure ages than iron meteorites, but are also differentiated and apparently came from a planet-sized body), and with many inner-belt asteroids. Comets created by any explosion older than 10 (million years ago) would have long since vanished because of galactic tides and passing stars. The population of Earth-crossing asteroids from this event would now be reduced to a fraction of its original number. And *this may have been the event that delivered large quantities of water to the inner solar system, most notably to Mars (which may have still been one of Planet V's moons at the time of the explosion).*

The event at 3.2 (million years ago) that resulted in all comets that survive to the present must have been the explosion of a much smaller body in the asteroid belt. I associate this latest explosion with chondritic meteorites (which are undifferentiated, and must therefore have come from a smaller parent body), with most present-day Earth-crossing asteroids... The

parent body was apparently a moon of another planet (presumably of the former Planet K or Planet V)...in many respects, the body that exploded perhaps resembled the largest asteroid, Ceres, which we have previously suspected of being a former moon of Planet K. [47](#)

Here the probable abundance of water on one of the (now two) original exploded planets becomes critical, since “evidence of water erosion on achondritic meteorites, presumed here to have originated from Planet V, indicates that the exploded planet contained abundant water as well, much of which would have hit Mars.”[48](#) And that, of course, would explain the evidence for massive, sudden flooding in the southern hemisphere of Mars.[49](#)

In this revised scenario, Van Flandern has both Mars and a smaller body (which he calls C) as satellites of Planet V, which, once released by the explosion, evolve into a small double-planetary system. Then, C exploded ca 3.2 million years ago, peppering Mars with craters and inundating it with water and giving rise to massive volcanism. [50](#)

4. Problems of the Revised Hypothesis

a. The Commonality of Planetary Explosions

It will now be evident what the problem of the revised “multiple exploded planet hypothesis” is. Simply put, it is that explosions of planets, having been a rare occurrence in the original version of the theory, the one that prevailed from Olbers to Van Flandern’s first version, is now a disquietingly commonplace occurrence in the revised theory: “The recent discovery of another belt of asteroid-like objects orbiting the Sun beyond Neptune has forcibly brought back to our attention the possibility that planetary explosions may be relatively common events, as uncomfortable as that thought is.”⁵¹

b. Mars

(1) And “the Flood”

As has been evident throughout the discussion of Van Flandern’s exploded planet hypothesis both in its original and in its revised forms, Mars plays a crucial role, for the hypothesis is the only rational contender for the strong evidence of a massive, sudden planetary inundation by water that Mars exhibits. Indeed, as I have remarked elsewhere, Mars alone of all the planets in the solar system has the best geological evidence for the type of Flood described in the Old Testament and in other ancient legends and traditions. Indeed, the severe hemispherical disparity one encounters on Mars is exactly explained by the hypothesis, for “one hemisphere would have been heavily bombarded, and the other barely touched by the explosion.”⁵²

(2) Debris

Under such conditions as these, one would expect not only that Mars’ atmosphere, magnetic poles, but also its polar alignment would be severely effected. More importantly, the explosion of a nearby planet, whether V or C, would strew Mars with craters and debris of the event, at once inundating it, and possibly stripping it, of water, atmosphere, and whatever life might have existed there. And if, as we have speculated, the original Planet V supported intelligent life, then Mars may have been inundated with debris of a very different, artificial, nature.

And this raises the question of the so-called “Face” on Mars and the equally, if not much more mysterious and apparently anomalous structures nearby in the Cydonia region of Mars, namely, the so-called “Fort”, “Tholus” and the various pyramidal and tetrahedral structures, including the famous “D and M” five-sided Pyramid. By the nature of the case, Van Flandern believes that these structures if artificial, were built by some civilization prior to the event at 3.2 million years ago. [53](#)

(3) Mars’ Excess Xenon 129

But there is an even more anomalous feature about Mars that must be explained than some anomalous formations and possible structures on the surface of Mars. Mars, as it turns out, not only has an unusually thin atmosphere for a planet of its mass - a consequence of the fact that most of it was literally blown away in the explosion⁵⁴ - but its content of the isotope Xenon 129 is almost three times that on any other planetary body. But Xenon 129 is a by-product of nuclear fission and does not ordinarily arise from normal processes. ⁵⁵ Mars’ proximity to an exploding planet might explain such a phenomenon.

c. What Mechanism Can Explode a Planet?

But Van Flandern’s mention of the anomalous Xenon 129 content of Mars’ atmosphere raises the possibility of other explanations for its occurrence. As I have already noted in my previous book *The Giza Death Star Deployed*, Mars researcher Richard Hoagland points out that the phenomenon of double-cratering and odd damage patterns on the D and M pyramid might indicate a *non*-natural mechanism was at work on Mars: nuclear war. And this highlights what is the most basic problem with the Exploded Planet Hypothesis - in whatever version one encounters it - and that is, what mechanism can explain why planets should suddenly explode?

The problem is not a small one, nor will it go away, for while the Exploded Planet Hypothesis does explain a tremendous amount of data, it does not do so well when it comes to explain why a planet should explode to begin with. After all, while exploding planets may be a common occurrence in the revised theory, they are not so common that they have ever been observed in modern astronomical history.

One mechanism for exploding a planet, that favored by Zechariah Sitchin and many other catastrophists, is that a large body entered the solar system, and collided with the now missing planet, causing both to explode and consume themselves. Van Flandern dispenses with this possibility rather quickly before proceeding to outline his own speculations:

Unless the exploded planet was a lot less massive than the evidence suggests, chemical or collisional processes do not generate enough energy to blow it apart. Nuclear processes are indicated by the meteoric evidence. It has been objected that planets are not hot enough even in their cores for nuclear reactions. Yet natural fission reactors have been known to operate even on the Earth’s surface in the geologic past, suggesting related possibilities. [56](#)

True enough, but one must also mention that for a full order nuclear explosion to occur by *fissionable* processes, rather pure uranium 235 or plutonium 239 must be assembled into a critical mass rather quickly, and one simply would not be able to assemble *enough* critical mass of any known fissionable substance quickly enough to produce an explosion *large* enough to explode a planet of even modest size. There simply is no model for it.

Perhaps sensing this difficulty, Van Flandern immediately goes on to suggest a more viable mechanism:

But the most natural way to produce the isotopic anomalies observed in meteorites, and supply abundant energy, is by a matter-antimatter explosion. This speculative possibility might result from a magnetic separation and storage of the antimatter in a planet over billions of years before the explosion; or from some sort of chain-reaction high-energy antimatter generation process.⁵⁷

But again, there are problems with that scenario, for Van Flandern's suggested matter-antimatter separation and storage model suggests that such "antimatter accumulation" is a natural event in massive planetary bodies, and that in turn would not only suggest that exploding planets are a rather commonplace occurrence, but also that large accumulations of anti-matter can be stored and kept separate from matter by natural causes! Yet, no exploding planets have been observed in modern astronomical history. More importantly, it has not been demonstrated that antimatter can even *occur* in the large amounts seemingly suggested by Van Flandern's speculative model, much less stored and maintained separately by natural causes for a prolonged period of time.⁵⁸ In the end, one is left with the most significant problem of them all: planets just do not suddenly and spontaneously explode. There is simply no good model to explain such an event by natural causes.

And this leads to Van Flandern's last suggestion, the one that simultaneously is the most radical and yet, the most plausible; the explosion of a planet might result "from the intervention of intelligent beings. In my opinion, the last possibility should not be dismissed out of hand."⁵⁹ "Intervention by intelligent beings" implies the existence of such beings in the first place, and secondly, implies their knowledge of a physics capable of blowing up a planet, and their possession of the technological means of doing so. This is a consequently breathtaking statement for someone of Van Flandern's stature to make! Van Flandern is gingerly and delicately implying that his exploded planets might have been blown up in deliberate acts of war. Yet, as will be seen in Part Two of this book, it is precisely *this* model that the abundance of ancient texts actually supports!

(1) The Relevance of the Modern Fictitious Scenario

Van Flandern's scenario of "intervention by intelligent beings" now highlights the relevance of the fictitious scenario that began this chapter, for clearly, one such motivation for an "intervention by intelligent beings" would be precisely to protect their world from a catastrophic collision with ...an asteroid. But unfortunately, the possession of a technology sufficient to defend against such a threat also inevitably implies the existence of a technology that can be used for a similar purpose in war.

As Van Flandern has pointed out in the above series of quotations, such collisions, while catastrophic to the planet undergoing them, even to the point of the near extinction of all life on it, are *not* really plausible explanations for the explosion of the entire planet itself. Moreover, there is an even more pressing problem with this “intervention” to destroy a wandering planetary body like an asteroid, and that problem is highlighted by the Exploded Planet Hypothesis itself: *asteroids are the result of planetary explosions*. In other words, in order to defend against an asteroid, one must first explode a planet to begin with. After all, this is how the Exploded Planet Hypothesis began, as an explanation for the existence of asteroids. And there’s the rub, for no good mechanism exists for why a planet should suddenly and spontaneously explode, *barring “intervention by intelligent beings.”* and thus, inexorably, one is faced with the real cause of the exploded and missing planet:

War.

(2) Rilles: Water? Or Something Else? The Problem of Peratt

But what type of war? And what types of *physics* does exploding a planet imply? What types of *weapons* might be constructed upon that physics? Clearly, to explode a planet would require a truly vast amount of energy. Van Flandern points the way forward in two unlikely passages:

Recent examination of the global distribution of interstellar hydrogen “clouds” by G. Verschuur suggests that the majority of the observed ones actually are parts of filaments (as would result from a supernova explosion), are quite young, and lie within 100 parsecs of the Sun. This surprising result suggests a linkage with the planetary breakup in the solar system.⁶⁰

Such filaments are but one step away from the electrical plasma filaments that Swedish Nobel laureate and plasma physicist Hannes Alfvén posited to exist in huge inter-galactic electrical currents. Such enormous energies imply, of course, energies not only sufficient to the task of at least seriously scarring and searing planetary surface, but also a deeper physics capable of blowing one up.

But is there any evidence for this type of huge electrical discharge in the solar system?

Van Flandern indicates just such a class of evidence:

Mars displays evidence that there was enough water for a brief period to produce flowing rivers and channels, although that would be impossible today. Sinuous rilles on the Moon and Mars are almost certainly water-carved features, and relatively recent as well, judging from the lack of overlying craters. The assumption that they must be from lava flows is inconsistent in some cases, since the rilles don’t slope away from potential lava sources, and neither lava nor any other candidate substance is not known to carve sinuous features.⁶¹

As we shall see in the next chapter, however, some of these Martian and Lunar rilles point not to water as their origin, but precisely to gigantic electrostatic discharges. They point to a physics sufficient to the task of planetary scarring of large areas of a planet’s surface, to a physics that is

weaponizable, and most importantly, to human observers of the events. And *that* physics in turn points to an even *deeper* physics, one that might be capable of exploding an entire planet.

In short, the rilles point to plasmas and to “the problem of Peratt.”

THE THUNDERBOLTS OF THE GODS: PLASMA COSMOLOGY, PLANETARY DESTRUCTION, AND THE PROBLEM OF PERATT

“Who would have guessed that the myths of ancient cultures could throw new light on the mysterious surface features of planets and moons? Or give new meaning to current work in artificial-lightning laboratories?” [62](#)

Mel and Amy Acheson [62](#)

A. Plasma Cosmology and Ancient Mythology

One of the more recent and serious entries into the question of the existence of an ancient paleophysics must surely be plasma cosmology. Brainchild of Swedish physicist and Nobel laureate Hannes Alfvén, plasma cosmology is a significant departure within mainstream physics from the “Big Bang” cosmology spawned by Einstein’s relativity theories and pursued by most cosmological physicists. In Alfvén’s view, the most important force in the universe is not the geometry of gravity, as with relativity-based cosmological theories, but electromagnetism, and the complex geometries of rotating plasma vortices. In Alfvén’s view, electromagnetism spans all scales, from the very small to the very large, including star-and-planetary systems, to whole galaxies, to the even larger scale of clusters of galaxies. This is another way of saying that our own galaxy and solar system are not electrically neutral, but rather, electrically dynamic systems.

Eric J. Lerner - a noted plasma physicist himself and author of the best layman’s study of plasma cosmology, *The Big Bang Never Happened* - traces Alfvén’s fascination with plasmas to his boyhood experiences in Sweden, where Alfvén “was fascinated by the spectacular displays of the northern lights, the moving curtains of filaments and spikes.”⁶³ Alfvén even quipped humorously that “Our ancestors called them ‘the Spears of Odin,’”⁶⁴ a statement as we shall soon see that may not be a joke after all, but a significant clue into a paleophysical problem discovered by fellow plasma physicist Anthony Peratt.

What Alfvén soon began to notice, however, was that the same filaments that he saw in aurora displays were also being found in his laboratory:

“Whenever a piece of vacuum equipment started to misbehave, there they were,” he recalls. They were there too, in photographs of solar prominences and of the distant Veil and Orion nebulas....

Many investigators had analyzed the laboratory filaments before, so Alfvén knew what they were: tiny electromagnetic vortices that snake through a plasma, carrying electrical currents. The vortices are produced by a phenomenon known as the “pinch effect.” A straight thread of electrical current flowing through a plasma produces a cylindrical magnetic field, which attracts other currents flowing in the same direction. Thus the tiny current threads tend to “pinch” together, drawing the plasma with them.. The converging threads twine into a plasma rope, much as water converging toward a drain generates a swirling vortex, or air rushes together in a tornado. The filaments are plasma whirlwinds.⁶⁵

Lerner explains the implications of this important phenomenon as follows:

Magnetic fields and currents can concentrate matter and energy far faster and more effectively than can gravity. The magnetic force of a plasma thread increases with the velocity of the plasma. This leads to a feedback effect: as threads are pulled into the vortex, they move faster, which increases the force on the threads of current and pulls them still faster into the filament. In addition, a contracting mass tends to spin faster and faster, like an ice skater who pulls in his or

her arms. This generates a centrifugal force which fights the contraction. Magnetic filaments can carry away this excess spin, or angular momentum, allowing further contraction, while gravity cannot.⁶⁶

Lerner reproduces the following diagram to illustrate this “pinch effect:”

*Pinching Effect of an Electrical Current in a Plasma*⁶⁷

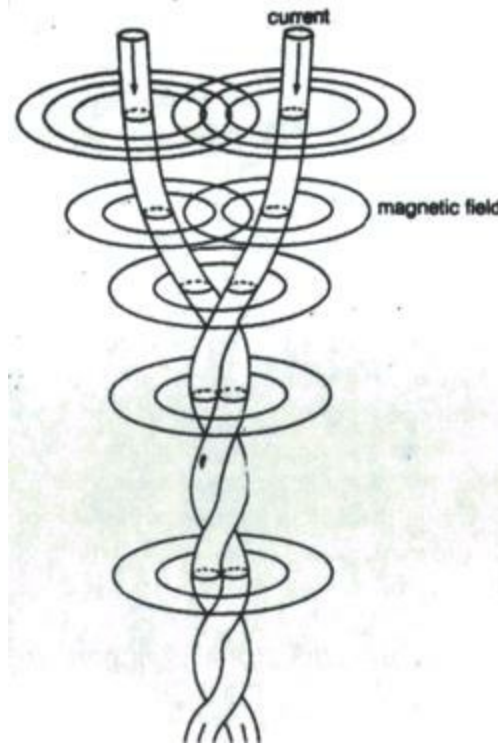

One unique component of Alfvén’s theory was its ability to be applied to systems of any scale, from the very large to the very small. “Plasmas should look similar no matter how big or small they are. ‘If we can extrapolate from the laboratory to the solar system, which is a hundred trillion times larger,’ he asks, ‘then why shouldn’t plasma behave the same way for the entire observable universe, another hundred trillion times larger?’”⁶⁸ Consequently,

In his theory, a galaxy, spinning in the magnetic fields of intergalactic space, generates electricity, as any conductor does when it moves through a magnetic field... The huge electrical current produced by the galaxy flows in great filamentary spirals toward the center of the galaxy, where it turns and flows out along the spin axis. This galactic current then short-circuits, driving a vast amount of energy into the galactic core. The galaxy “blows a fuse”: powerful electrical fields are created in the nucleus which accelerate intense jets of electrons and ions out along the axis (of spin).⁶⁹

Thus, as fellow plasma physicist Anthony Peratt demonstrated, computer generated simulations of this electromagnetic plasma pinch effect are able to generate the familiar forms of spiral galaxies, as the

following pictures show (reading the pictures time-wise from left to right, then down the page):

*Computer Simulations of Plasma Pinch Effects Over Time*⁷⁰

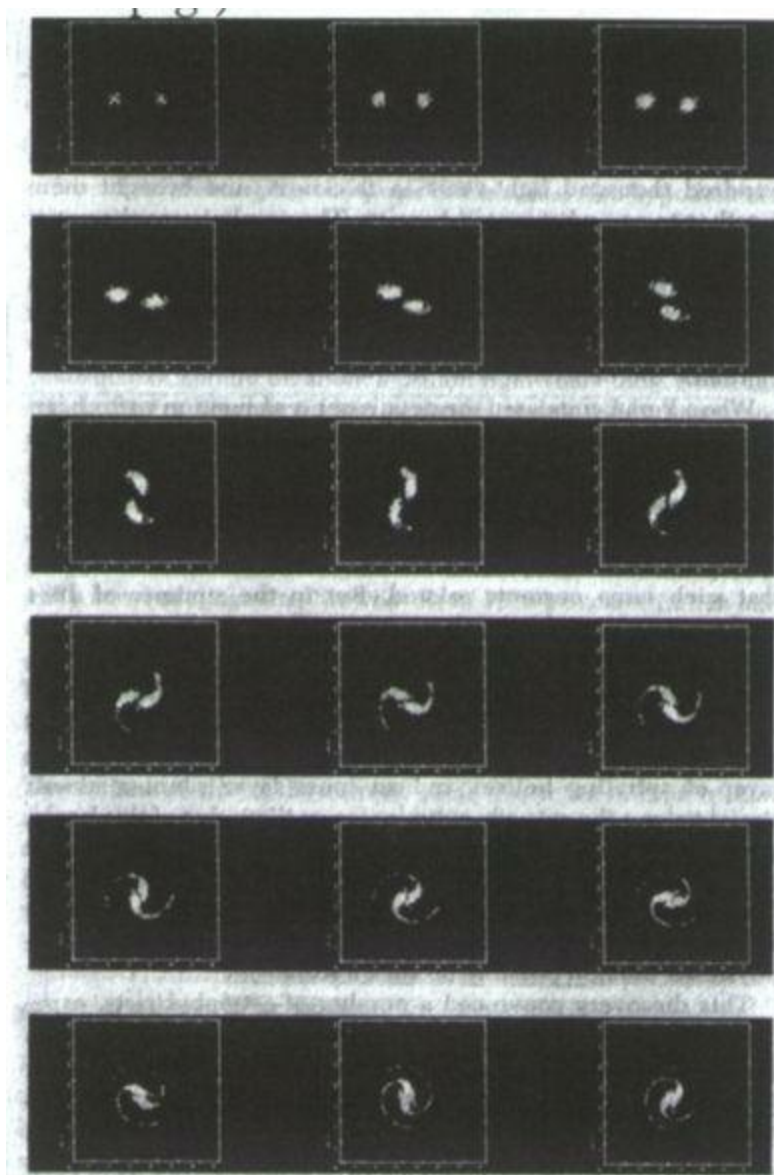

Peratt was able to demonstrate even more stunning correlations between these computer simulations and actual galaxies, for he found that he “could link up each picture of a galaxy with some stage of one of my simulations and I knew exactly what forces - electromagnetic forces - were shaping the galaxies.”⁷¹ Lerner reproduces Peratt’s simulations and the galaxies - 3C66, 3C285, NGC3187, NGC1300, and M95 - that he compared with his simulations. The results are stunning:

*Comparison of Actual Galaxies with Peratt’s Computer Simulation*¹¹

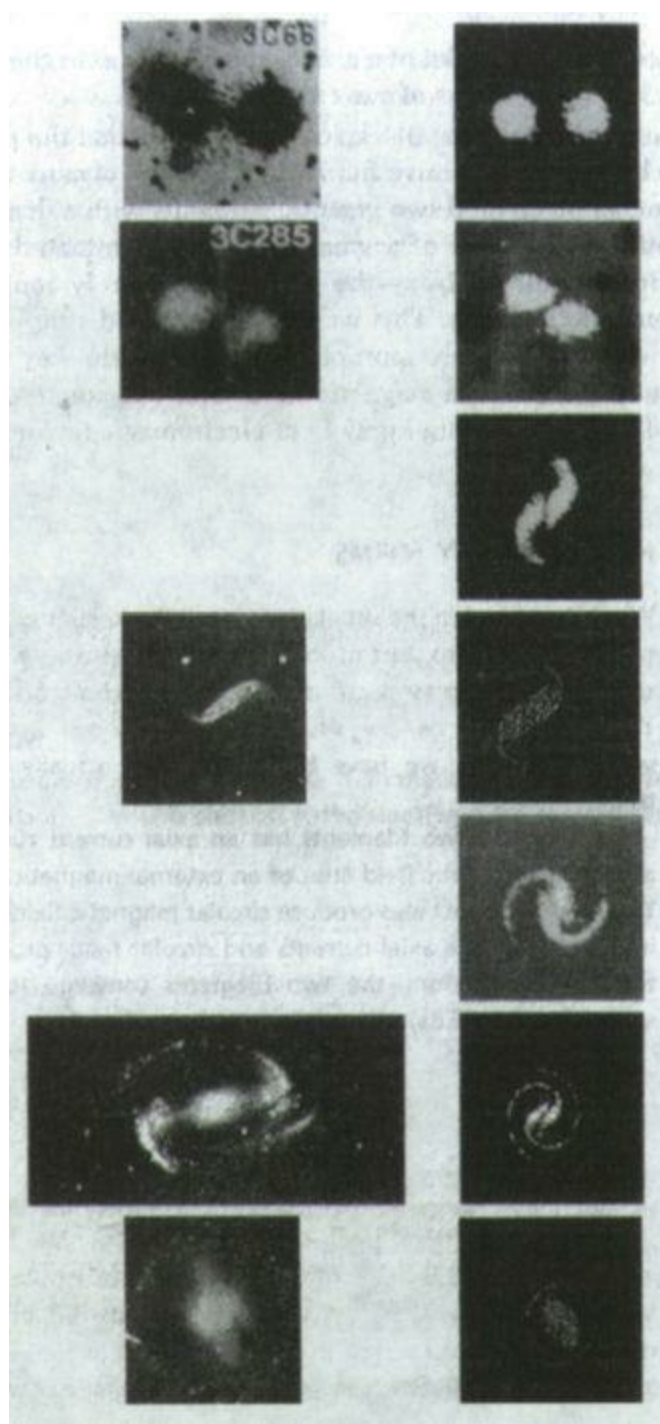

The implications of plasma cosmology for the hypothesis of an ancient interplanetary war, fought with horrendously powerful weapons, now begins to take on significance, for if a planetary system such as our solar system, or a galaxy such as our own Milky Way, are not electrically neutral, then the same basic technology that allows such simulations to be made, might, on a larger and more sophisticated scale, also be able to tap into these enormous supplies of energy for either good or ill. In short, such a principle could conceivably be weaponized, and if weaponized, then it becomes entirely feasible that exploding a planet would be child's play for the very energy of an entire planetary system, much less a galaxy.⁷²

And these observations bring up...

1... *The Problem of the Mercury Rectifiers.*

Alfvén was soon confronted by a new phenomenon associated with plasmas: the sudden and explosive release of energy. As Eric Lerner puts it:

By forming the filamentary structures observed on the smallest and largest scales, matter and energy can be compressed in space. But it is clear that energy can be compressed in *time* as well - the universe is filled with sudden, explosive releases of energy. One example that Alfvén was familiar with is the solar flare, the sudden release of energy on the sun's surface, which generates the streams of particles that produce magnetic storms on earth... Understanding the explosive release of energy was the key to the dynamics of the cosmos.

Again, Alfvén and his colleagues drew inspiration not from mathematical theory, but from their practical work in technology. In the late fifties, Alfvén and others at the Royal Institute had been called in by the Swedish Power company, ASEA, to solve an urgent problem. Most of Sweden's electrical supply is generated by hydroelectric power in the north of the country, and is then transmitted over six hundred miles to the industrial south. ASEA found that it was cheaper to transform the alternating current to direct current for transmission with large mercury rectifiers. A rectifier allows a current to pass in only one direction, holding it back for the other half of the cycle, thus producing DC. But every so often a rectifier would explode, causing considerable damage.

Herlofson and Alfvén were consulted because the rectifier mechanism, consisting of a low-pressure mercury vapor cell, employs a current-carrying plasma. The team from the Royal Institute rapidly located the problem: the pressure of the mercury vapor in the rectifiers was too low. As a result, at high currents nearly all the electrons carried the electrical flow, creating an unstable situation in which the plasma started to slosh about within the rectifier.

...(At) high current something else happened. If the ions accidentally spilled out of a region, the electrons in the current *would rush toward the ions with such momentum that their collision pushed the ions farther out of the region.* This accelerated the electrons more, and so on. *However, a few ions would break away and accelerate toward the electrons on the other side, pushing most of them back. An ever-widening tear in the plasma would open up, with electrons bunching up on one side and ions on the other. As the gap widened, fewer electrons could pass, so the current... would drop. This is like unplugging an appliance. The drop in current produces a sudden drop in the magnetic field created by the current, and the changing magnetic field creates a powerful electrical force that further accelerates the electrons. In the case of an unplugged appliance, the voltage becomes high enough to make a spark jump across from the socket to the plug. In the case of the rectifier, the voltage builds and builds until the electrons heat the rectifier plasma so hot that an explosion ensues, and gigantic sparks jump through the air in the station. Energy is suddenly released, creating the explosive damage.*⁷³

Note what is really being said here. Since ions - the protons and neutrons of an atom separated from

their electrons - constitute most of the mass of any given substance, the mercury rectifiers, in this unstable state, were pushing the mass of the mercury *away from* the rectifier itself, that is, an anti-gravitational (or more aptly, a contrabarcic) effect was being created. Note secondly that the same basic technology *also* could be used to produce an explosion.

And this brings us, surprisingly, to the Nazis.

2. Plasma Pinch, Plasma Focuses, and the Nazi “Bell” Project

Lerner’s interest in plasma cosmology led him to investigate controlled fusion research, and to a fusion researcher named Winston Bostick.

Bostick’s research centered on a fusion device called the plasma focus. This focus - *invented independently in the early sixties* by a Soviet, N. V. Filippov, and an American, Joseph Mather - is extremely simple, in contrast to the huge and complex tokamak, a large magnetic device that has long dominated fusion research. *The focus consisted of two conducting copper cylinders, several centimeters across, nested inside each other... When a large current is discharged across the cylinder, a remarkable sequence of events occurs.* [74](#)

But for readers of my two books on Nazi secret weapons, *Reich of the Black Sun*, and *The SS Brotherhood of the Bell*, this construction of two nested cylinders across which a large current is discharged will sound all too familiar, for this is the exact principle of construction of the Nazis’ most highly classified wartime secret weapons project, “the Bell.” And like Alfvén’s “mercury rectifiers,” the “Bell” utilized a mysterious compound code named “IRR Xerum 525,” a violet-reddish hued liquid compound that I speculated was some isotope of mercury and other elements. This compound was placed into the cylinders of the Bell, and subjected to intense electrical pulsing. The only difference between the Bell and Bostick’s plasma focus (and indeed, between it and all other plasma focuses) is that the Bell’s two cylinders were *rotated in contrary directions to each other*, a simple but brilliant expedient that the Nazi scientists had hit upon for the cohering [75](#) of the spin of the atoms-soon-to-be-ions of mercury and other substances that they were experimenting with. Additionally, the Nazi scientists also added one more factor: they *cooled* this mysterious substance inside the Bell with liquid oxygen or nitrogen. These sophisticated additions would have, in all probability, have made the Bell a much more efficient device than the common plasma focus. [76](#)

In any case, Lerner reproduces the following schematic of a plasma focus device:

Plasma Focus Device [77](#)

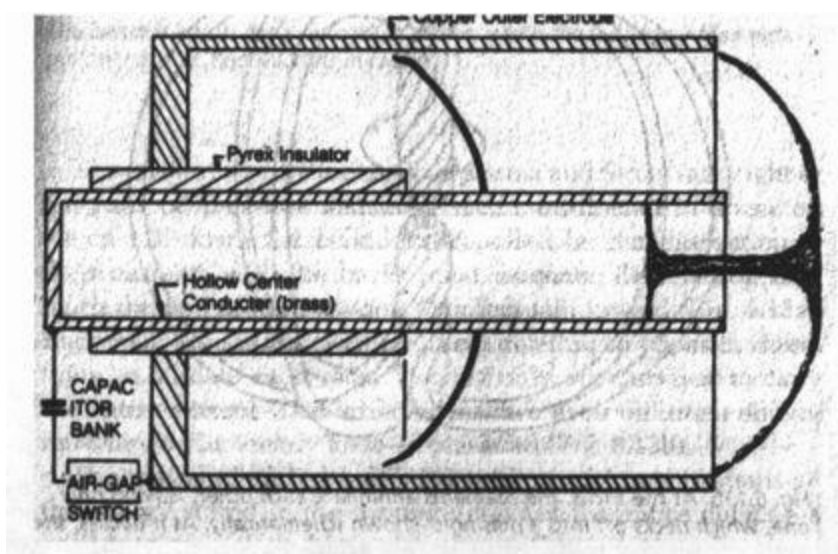

But what happened when Bostick turned on this device?

Lerner states that the plasma inside the device is rapidly ionized by the current, forming into “eight or ten pairs of force-free filaments” which then begin to “roll down the cylinder, propelled by the interaction of their currents with the background magnetic field.” At this juncture, an amazing thing happens:

When they reach the end of the cylinder, they fountain inward... Each pair, consisting of two vortices rotating in opposite directions, annihilate each other, leaving only one survivor to carry the entire current. This survivor pinches itself off into a doughnut-shaped filamentary knot - a plasmoid.⁷⁸

Lerner then reproduces the following diagram of the minute plasmoid

*Schematic of a Plasmoid*⁷⁹

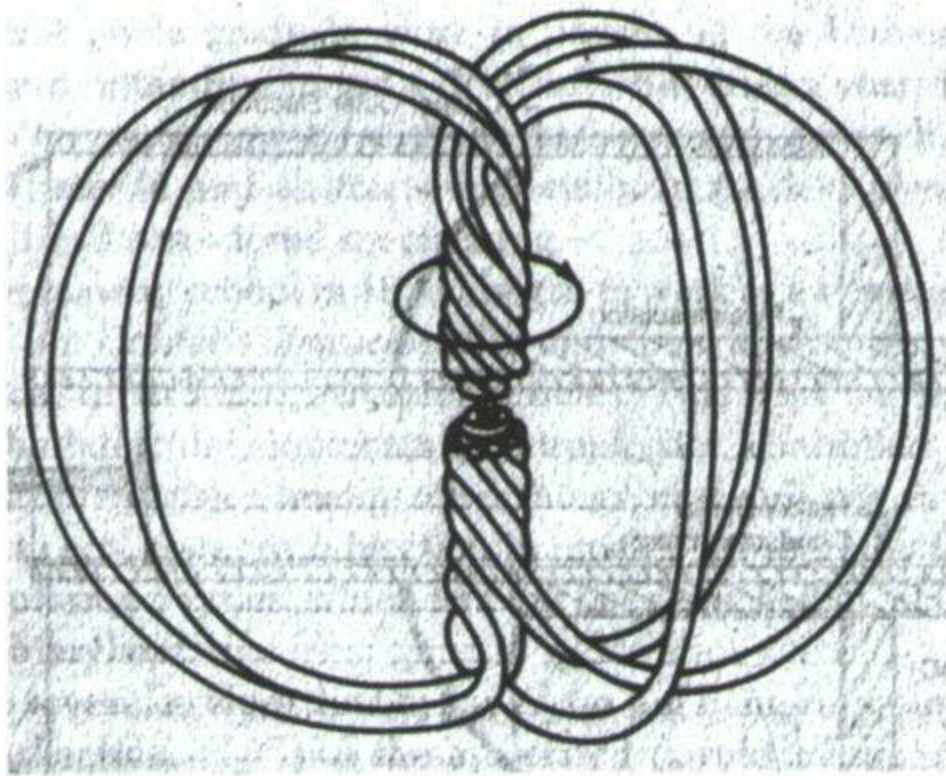

Lerner continues:

The plasmoid, only a half-millimeter across, *now contains all the energy stored in the magnetic field of the entire device - a million or more times bigger*

in volume. For a fraction of a microsecond, as the plasmoid continues to pinch itself, it remains stable. But as its magnetic field increases, the electrons *orbit in smaller circles, giving off radiation of a higher frequency.* Because plasma tends to be opaque to low-frequency radiation and transparent to high-frequency, *the radiation suddenly begins to escape.*

This sets in motion a second series of events. As the electrons radiate their energy away, the current drops and the magnetic field weakens. Since the electrons are traveling along magnetic field lines, the weakening field tangles the electrons' path up as its shape changes - causing the current to drop still further.

The result is like turning off a switch, as... Alfvén had observed. The falling magnetic field generates a huge electrical field, which shoots two high-energy beams out of the plasmoid - the electrons in one direction, the ions in the other. The beams consist of extremely dense, helical filaments, each a micron (one ten-thousandth of a centimeter) across. In the course of this process some ions are heated to such high temperatures that they fuse.... *A plasma focus can increase the power density of its emissions by a factor of ten thousand trillion over that of the incoming energy - comparable to the ratio of a quasar to a galaxy.* [80](#)

But what would happen if, at the very moment that the electrons begin to radiate away their energy, setting up the collapse of the magnetic field, they were pulsed again? Such would indeed appear to have been one of the principles behind the Nazi Bell. [81](#)

In any case, several things are now clear.

First, the simple expedient of a plasma focus allows one to access a multitude of phenomena, from anti-gravitational effects, to thermonuclear fusion - the same basic explosive energy behind the hydrogen bomb - to deadly radiations in the form of high frequency electrons and ions, deadly streams of electrical energy.

Secondly, *if such energy could be tapped at a "celestial" scale a weapon of extraordinary power could be based upon it.* Since plasma cosmology shows the same effects from the very small to the very large, this should theoretically be possible.

Thirdly, it is clear that the idea of accessing this energy *did not begin with the Russians and Americans in the 1960s but fully two decades before, with the Nazis.*⁸² *By counter-rotating the two cylinders of a typical plasma focus, by utilizing what was probably a radioactive compound to begin with as its plasma-forming fuel, and by super-cooling that material, it would appear that the Nazis made such great strides in plasma technology and its uses that their ideas have yet to be duplicated.* A case in point is that no one to my knowledge has since thought to rotate the two cylinders of the focus, much less rotate them in opposite directions!

As I indicated in my book *The SS Brotherhood of the Bell*, the Nazis' interest in pursuing this arcane line of research might very well have been motivated by their knowledge of occult texts, such as the ancient Hindu "vimana" texts that refer to aircraft propelled by using *mercury* as fuel. In short, they may have been deliberately investigating the ancient traditions and legends of the gods and their wars for their paleophysical content and potentials. In this regard it should be noted that Germany, throughout the late nineteenth and early twentieth centuries, was not only a home to scholarly research into the ancient Vedic culture of India, but even more so into the ancient cultures of Mesopotamia: Sumer, Babylon, Akkadia, and Assyria. The legends of the wars of the gods were therefore very well known by the Nazi regime. It therefore stands to reason that the texts that we will examine in part two of this book might have formed the mythological impetus and motivation to some of their research.

But there is also another way that plasmas enter into the question of paleophysics, as we shall see momentarily.

3. Plasma Physics, the Plasma Focus, and Scalar Physics

How might one access this relatively simple technology and physics *at the “celestial” scale and weaponize it to explode a planet, and do so from a “safe” distance?* It is here that there are direct, though little publicized, connections between plasma physics and the even more arcane world of “scalar” or “quantum potential” physics.

Throughout my works I have repeatedly made reference to the work of scalar physics theorist and exponent, Lt. Col. (US Army, Ret) Tom Bearden. It is necessary to do so once again.⁸³ Bearden maintains that at the core of the theory of scalar physics are three relatively obscure, highly mathematical, entirely pre-relativistic, and *immensely unusual* papers. Two of them were by the well-known mathematician and theoretical physicist E.T. Whittaker, and one was by a physicist named Barus. Of the three, the Whittaker papers are breathtaking in their implications, not the least of which because they can be made to work within the context of the later-developed quantum theory.

The first paper, a lengthy and highly mathematical tome, is a masterpiece whose full implications - in spite of its benign and somewhat intimidating title “On the partial differential equations of mathematical physics” - are spelled out by Whittaker in the conclusion of the paper (I have italicized the significant portions that bear directly on Bearden’s analysis which follows):

*It is clear from the foregoing that the field of force due to a gravitating body can be analyzed, by a “spectrum analysis” as it were, into an infinite number of constituent fields; and although the whole field of force does not vary with time, yet **each of the constituent fields is of an undulatory character, consisting of a simple wave-disturbance propagated with uniform velocity...** In each of these constituent fields the potential will be constant along each wave-front, and consequently the gravitational force in each constituent field will be perpendicular to the wave-front, **i.e., the waves will be longitudinal.*** ⁸⁴

The significance of this short paragraph may be missed unless one remembers that E.T. Whittaker was also a physicist who believed ardently in the *aether*, i.e., in a medium or mechanism of electromagnetic energy propagation. Indeed, he is the same Whittaker who wrote a classic history of the concept of the aether. Note also that this paper was originally published in *Germany*, and therefore, the Germans could hardly have been unaware of its existence or of its importance as a *non-relativistic* physics as they sought to explain the curious anomalies of.. their late war radar experiments. Indeed, their experiments with radar, and even the Bell itself, are evidence that they were pursuing this “scalar physics” with a vengeance.

To understand what Bearden means by “scalar” waves in the medium or vacuum, we must now go further into the history of where public consumption physics went wrong. According to Bearden, it began to make its first massive wrong turn after Maxwell. Maxwell first formulated his equations in a mathematical language all but extinct today, a mathematical language called quaternion geometry. This mathematical language differs significantly from the standard “linear algebra,” “tensor calculus” and “vector analysis” in which the standard electromagnetic theory is usually couched in textbooks and physics lectures. In short, the equations one learns in physics textbooks and physics courses today

as Maxwell's equations are not Maxwell's original equations! They are *edited* equations. But to understand what effect this simple change of mathematical language - from quaternions to vector analysis - had on physics, we need to understand a few simple concepts.

First, there are two types of effects that electromagnetic fields can have on charged particles: (1) translation, and (2) stress. There are two types of translation, or movement. The first type is simple translation in a straight line, producing the electrical, or "E" field itself. The second type of movement is that of a spiral, mathematically symbolized as the "B" field. We will not be dealing with the "B" field immediately.

Now let us assume there are two vectors, E_1 , and E_2 , acting upon a particle as shown:

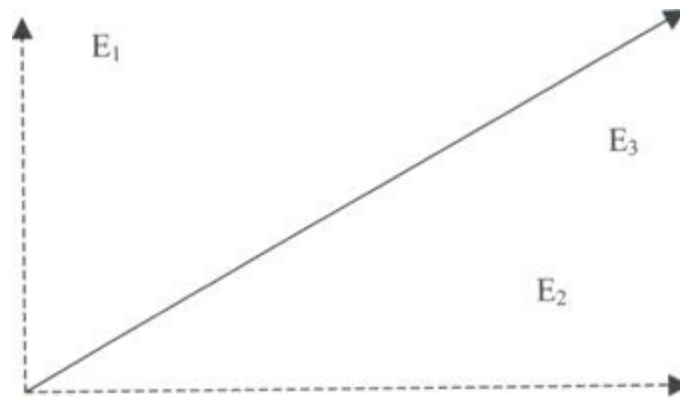

The result is a translation in the direction of vector E_3 as the two vectors are added together to get a result, which is called aptly enough, a "resultant" vector. Thus, in systems where a large number of translation vectors are involved, "the entire system can be replaced by a single vector," the resultant, which describes the *actual* translation that results from the original vectors.⁸⁵

Now observe that if no translation occurs, the resultant is a "zero vector." However, one must always recall that one is dealing with *geometry* and not simply *mathematics* or *numbers*. One can therefore envision a multitude of multi-vector systems resulting in a zero translation vector, and yet *which have profoundly different internal stresses and geometries*:

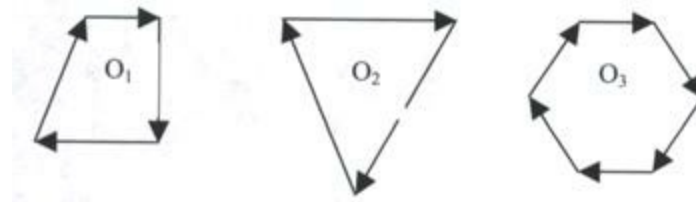

If one were trained to think only in terms of the conventions of linear algebra to replace multi-vector systems with a resultant vector, then in each of the three cases or systems above, one will replace the entire system with a *zero resultant vector*. This means that the *internal stresses of the systems and their rotational characteristics* - each obviously quite different - are all replaced by a zero vector, and thus the three systems are erroneously reduced to physical equivalence by a mathematical convention!

Now we are in a position to see what a scalar is, and why Maxwell deliberately chose quaternion

geometry to write his equations, for he had in mind when he did so precisely the types of physical *stress* situations that are simply represented by the vortices in the above diagram.

In standard linear algebra, each of the arrows in the above system would be mathematically represented like this:

$$v(\text{vector}) = ai + bj + ck.$$

Thus, if the total sum of all such vectors is no translation, then one will replace all such mathematical expressions with a zero vector. But as we have seen, each of these systems contains an internal rotation or stress, so *something* remains. The question is, how to represent it mathematically?

In quaternion geometry, a quaternion is simply a “scalar” plus a “vector,” and a “scalar” is simply a *pure magnitude*, a “number” that has no *direction*. It simply “is.” Thus, a quaternion (q) is a scalar(s) plus a vector (v):

$$q = s + v$$

Substituting our previous expression of a vector into this, we get

$$q = s + ai + bj + ck.$$

Thus, for the hexagonally shaped system above, one would have six different expressions resembling $q = s + ai + bj + ck$. Now imagine we multiply each of these vectors. According to the special rules in linear algebra for multiplying such things, we know that zero times zero is zero. So in linear algebra one would end up with nothing once again, a zero vector, since no translation has occurred. But in *quaternion geometry the scalars in our hexagonal vortex diagram, which are not zero, all multiply, and give - according to the rules of quaternion multiplication - the following result:*

$$q \times q = s^2 + t^2 + u^2 + w^2 + x^2 + y^2 + 0_{v},$$

where 0_v is the zero vector and the squared quantities are the multiplied scalars. Thus, in quaternion geometry the internal stress is preserved even though there is zero translation occurring. *The scalars thus represent pure magnitudes of force “locked within” a structure possessing no “direction” or “translation.”*

Now we are in a position to understand what scalar physics is: *it is **not** standard vector or “linear” physics in any sense, but is the **non-linear** physics of internal stresses in the local medium.*

We are likewise now in a position to understand the enormous implications of the end of Whittaker’s paper quoted above, implications that Bearden’s analysis makes quite clear:

(The) interference of scalar potentials - each of which is actually a set of longitudinal (electromagnetic) waves, and not a scalar entity at all, but a **multivectorial** entity - *produces* (electromagnetic) fields and waves and their dynamics. Hence we hypothesize that the Whittaker interference of the propagating reordered (electromagnetic) energy entities, continuously occurring at any point in space, generates the zero-point (electromagnetic) field energy

fluctuations of the vacuum itself. Indeed, (a) paper by Evans...has already shown that *just such “scalar interferometry” produces transverse (electromagnetic) fields and waves in the vacuum at a distance.* ⁸⁶

In other words, one must imagine each of the scalar entities accompanying the vectors in the diagrams above as being composed of bi-directional *longitudinal* or “acoustic” waves in the medium. Thus, Whittaker “decomposes” the scalar entities into pairs of such pressure waves or “stresses” in the medium. Combining, or “interfering” such waves thus causes the standard electromagnetic fields and waves observed in standard physics. And most importantly, this can be done “at a distance.”

But what does this mean?

Simply put, since every atom and every *type* of atom consists of particles with charge and/or mass, then every atom has its own peculiar “scalar signature” or “resonance” (recall the diagrams above and imagine the mathematical notations that would describe each in quaternion geometry). Thus, to produce an *effect* on any one of these systems, one simply has to “work backwards” as it were, and configure its scalar signature, decomposing each of the scalars into its own pair of bi-directional longitudinal pulses and waves.

One may thus envision the innumerable types of “zero sum vector systems” like the diagram above as also being a kind of *template for action*, or what Bearden calls a “causal system robot,” or CSR, *ε template for producing a desired outcome in a system at a distance by means of configuring resonance to its “scalar signature”*:

With sufficient theoretical development, one can “work backwards” to obtain a desired causal system... corresponding to some physical system... One thereby creates a deterministic set of spacetime curvatures and impressed dynamics, which we call an “engine.”...By building in scalar interferometry functions, the CSR can be given “weapons” capabilities, etc. ⁸⁷

That is, one reproduces the “scalar” or if one prefers the topological signature of the system one wants to influence (or destroy), and loads the appropriate information into it:

(By) assembling the desired (longitudinal) wave biwave subsets, the two scalar potentials and their resulting interference-produced carrier wave are internally structured *as desired*. This is the use of the so-called ***internal information content of the field***. We speak of a deliberately structured potential, field, or wave as having been ***conditioned, dimensioned, or activated***. If these terms are deemed inappropriate, just use the more generic term “internally structured.” ⁸⁸

By the well-known mass-energy conversion mechanism, mass and inertia are thus “the direct result of - and are - trapped scalar resonance.” But what is “trapped scalar resonance”? “The trapping mechanism is the spin of the particle,” ⁸⁹ that is, the peculiar internal rotating stresses or vorticies in the medium of various systems, diagramed in our simple example above! ⁹⁰

More than anything else, it is this ability to configure a template based upon the scalar signature and its long distance resonance effects in the medium that allows one to produce an action at a

distance that best fills the bill for the “monstrous area of physics” that the Germans were working on with the Bell. It is, indeed, a very sophisticated form of magic, and sympathetic magic at that.

For the result of this new physics is that space itself *has structure and content*, the medium or “aether” *may be viewed as nothing but a vast set of scalar potentials, which can be decomposed into longitudinal wave pairs.*⁹¹ And since a “scalar” represents an *internal rotational stress* - as per our diagrams above - scalar physics is also not only non-linear, but *vorticular* physics.⁹²

a. Bearden’s Claims for “Scalar” Physics and its Weaponization

(1) The Dangers of Scalar Resonance: Planet-Busting “Doomsday” Implications

In addition to a superb defensive capability, there is a far more ominous offensive capability. Since, as has been seen, “scalar waves pass through the electron shells of an atom and interact with the nucleus” directly, this means that “they are continually absorbed and emitted by all nuclei in the universe.” *Consequently, “any large collection of nuclei — such as a star or a planet - is a strong absorber and radiator of scalar wave radiation.”*⁹³ One cannot ponder this too long nor overestimate its importance, for it means that any large mass such as a planet is a *natural resonator* of such waves, and this means any scalar weapon has a planetary-sized potential destructive power:

(This) scalar coupling of the solar system provides a major check on unrestricted use of the large Soviet strategic scalar EM weapon systems. If significant scalar effects are produced or earth in a “pulse” mode, *pulsed disturbance of the earth-sun and earth-moon system results.* Here a danger exists that one or more natural resonances of the coupled systems may be excited. If the feedback stimulation of the Sun is not insignificant, for example, large sunspot activity may result sometime thereafter, say in a day or two. If too much or too sharp stimulation occurs on earth, the coupled resonant response from the sun could be disastrous. Indeed, a solar response could be stimulated so that the Sun would violently belch and destroy our biosphere, among other effects. The simplest doomsday stimulation would be for a violent expulsion of Solar (electromagnetic) energy and particles to occur. If this were due to resonance, the expulsion of Solar (electromagnetic) energy and particles would continue during some decay time. In that case, fiery destruction of the earth, strongly indicative of Biblical prophecy, would result....

Accordingly, use of huge scalar (electromagnetic) weapons is a double-edged sword. Unless carefully employed, use of the weapons could cause a terrible backlash to the user as well as the victim, and even accidentally cause the destruction of the earth itself.⁹⁴

One may even envision the use of a scalar weapon to acoustically oscillate an entire planet beyond its ability to damp the enormous cascade of quantum potential energy to the point that it would explode.⁹⁵ Bearden himself is quite alive to this disturbing potential for the weapons:

(If) the discharge happens to tickle the Sun and Moon's feedback loops the wrong way, you'll get convulsions of the earth, mighty burps of the sun raining fire and brimstone on the earth, and *a violent increase in the interior heat of the earth's molten core, with a concomitant eruption of that core right up through the mantle....*

(Whenever) one activates a large scalar (electromagnetic) weapon, one immediately places the entire earth in deadly peril. The slightest misstep, and it's curtains for everyone. And it's curtains for the earth as well.⁹⁶

It takes only a little imagination to see that this principle could be pressed even farther, to the inability of the planet to damp its violent, scalar-induced acoustic cavitation. The planet would consume itself in a violent explosion making a hydrogen bomb look like a firecracker.

But in any case, as Bearden makes abundantly clear, scalar weapons possess planet-busting potential.

Any number of mechanisms now suggest themselves for how one might access scalar phenomena, *for these are specifically, as has been seen, vorticular and non-linear in nature.* One might construct a "template" allowing one to unleash the tremendous electrical energy in a planetary system or to create enormous plasma discharges striking a planetary surface. Alternatively, one might use that energy itself to create powerful longitudinal standing waves in a target. In either case, there would be enormous electrostatic displays and acoustic cavitation in any planetary target just prior to its explosion.

And this brings us back to plasma cosmology, and to the "problem of Peratt." And the "problem of Peratt" is simply that he maintains that *ancient observers recorded precisely such displays - beyond those of a mere aurora borealis - on a celestial scale.*

B. Petroglyphs and Anthony Peratt: Plasma Paleophysics

Peratt's work is quite the crucial matter for any investigation of paleophysics along the lines of Alfvén's plasma cosmology, for not only is Peratt a respected physicist, but more importantly, his paleophysical investigations and comparisons of ancient American Indian petroglyphs with laboratory plasma discharges has been published in a series of papers in peer-reviewed journals.⁹⁷ Two of these papers - "Evidence for an Intense Aurora Recorded in Antiquity," and "The Origin of Petroglyphs" - were published while Peratt was associated with the Los Alamos National Laboratory, raising the question of whether or not his work and that of his fellow scientists at Los Alamos might involve such paleophysical investigations.⁹⁸ And a glance at his other research interests would tend to support that view, for these "include numerical and experimental contributions to high-energy density plasmas and intense particle beams, inertial confinement fusion, explosively-driven pulsed power generators, lasers, intense-power-microwave sources, particles, high-energy density phenomena, new concepts in space propulsion and high-performance computing," as well as his interest in plasma cosmology and cosmogony.⁹⁹ Peratt is consequently no light-weight New Age prognosticator. On the contrary, his interests and associations would seem to suggest in the strongest possible fashion that someone, somewhere in the corridors of power in government black projects is seriously interested in pursuing the avenues of paleophysics research that his investigations outline.

Plasma Physicist and Cosmologist Anthony Peratt



But what exactly has Peratt uncovered? Peratt himself puts the case with all the understated succinctness of a scientific abstract: "Based on the compilation and analysis of the order of 50,000 digitally recorded petroglyphs, we have identified several dozen general categories of instabilities of

a highly non-linear plasma column generally associated with multi-mega ampere Z-pinches. This suggests that prehistoric man recorded the occurrence of an intense and long-lasting aurora.” [100](#) By means of a “direct comparison of the temporal evolution of experimental instabilities with petroglyphs” Peratt demonstrates that “nearly all archaic carvings match the phenomena that might be produced in an intense and long-lasting aurora.” [101](#) In other words, the seemingly meaningless stick figures of many petroglyphs are not meaningless at all. They are the accurate recorded observations by humans of immense electrical and plasma phenomena on a celestial and planetary scale.

As if this were not enough, Peratt is even more explicit in his lengthy article, “Characteristics for the occurrence of a High Current, Z-Pinch Aurora as Recorded in Antiquity,” which appeared in the Dec 6, 2003 issue of the *IEEE Transactions on Plasma Science*. There Peratt states quite unequivocally that “it is found that a great many archaic petroglyphs can be classified according to plasma stability and instability data. As the same morphological types are found worldwide, the comparisons suggest the occurrence of an intense aurora, as might be produced if the solar wind had increased between one and two orders of magnitude, millennia ago.” [102](#)

For our purposes, this implies three significant things:

- (1) There is concrete worldwide evidence of a massive aurora phenomenon on a planetary scale from human prehistory, implying the existence of a physics able to produce such a phenomenon;
- (2) human beings existed contemporaneously with this phenomenon, *or* other intelligent observers existed who passed on their knowledge to subsequent humanity; and,
- (3) humans more or less accurately *recorded* it in the form of certain petroglyphs.

The last point is the most significant, for it is not yet an argument for the case that they may have accurately *understood* it, much less have *produced* it.

Having made this last all-important observation, however, it is highly suggestive and paradoxical that Peratt himself begins the main text of his article in the following fashion:

On July 9, 1962, the United States detonated a 1.4-megaton thermonuclear device in the atmosphere 400 km above Johnston island. The event produced a plasma whose initial spherical shape striated within a few minutes as the plasma electrons and ions streamed along the Earth’s magnetic field to produce an artificial aurora....

Concomitant with the artificial aurora was a degradation of radio communications over wide areas of the Pacific, lightning discharges, destruction of electronics in monitoring satellites, and an electromagnetic pulse that affected some power circuitry as far away as Hawaii. [103](#)

In other words, it is only with the rise of modern physics and its associated technologies that such large scale plasma and aurora phenomena can really be understood at all, since only these technologies allow it to be *artificially produced and studied in the laboratory*. That the “laboratory” in this case was the entire earth’s magnetic field and a 1.4 megaton hydrogen bomb detonated atmospherically should give one pause as to just what the implications may really be for an *ancient* human observation of similar large-scale auroral effects.

In any case, having begun his article in this thought-provoking fashion, Peratt passes immediately to a scientific consideration of the characteristics of auroral plasma columns and displays. These plasma instabilities come in two basic forms and may be observed over a wide range of electromagnetic frequencies.¹⁰⁴ The first type of instability is a “column” of many varieties of toroidal or vorticular structure. The second basic type is a “sheet.” Peratt notes that the first type may have dimensions of “hundreds of kilometers in diameter,” while sheets may be as wide as tens of kilometers.¹⁰⁵ The red, green and blue auroras that occur naturally in the earth’s atmosphere are easily explained as the natural result of atoms of nitrogen and oxygen in the atmosphere “de-exciting” from their plasma state.¹⁰⁶

In producing the various “mini-plasma” geometries in the laboratory, data was obtained from the U.S. Department of Energy “pulsed-power facilities at the Los Alamos National Laboratory and Sandia national Laboratories.” Additionally “high-explosive generators” from the United States and Russia also contributed to the data set. Currents ranged from a few hundreds of kiloamperes to approximately 150 mega-amperes.¹⁰⁷

Most notably, the geometries themselves were “generated by applying high-voltage pulses to gas-puffs to simulate an aurora-like plasma inflow... and concentric plasma sheets formed by nested cylindrical foils to produce high-velocity shock waves.”¹⁰⁸ The beautiful and evocative geometries that resulted were “a few centimeters in diameter and 203 centimeters in length.”¹⁰⁹

But what has this to do with petroglyphs? And what has any of it to do with paleophysics and the possible thesis of an ancient interplanetary war?

Again, Peratt points the way in his paper, for in spite of its scientific technicality, its real focus is not on the plasma geometries themselves, but on their uncanny resemblance to these ancient petroglyphs. Notably, Peratt focuses his attention on petroglyphs thought to be dated from 10,000 to 2000 BC.¹¹⁰ This is significant, for it may provide yet another anchor point for any eventual dating of the “war” scenario, and as we shall see, it falls within the latest possible temporal window for the cataclysmic events.¹¹¹

In the presentation of Peratt’s comparison of petroglyphs and the geometries of plasma instabilities, I will rely on the excellent summary of his work provided by comparative mythologist David Talbott, and Australian physicist Wallace Thornhill, from whose masterful and provocative book, *Tunderbolts of the Gods*, this chapter takes its name. Talbott and Thornhill’s study is an apt summary of

Peratt’s extensive research, reprising its more salient points and greatly expanding upon its cultural and historical implications.¹¹²

One of the most common of the petroglyphs is the so-called “Squatter Man,” an apparently humanoid stick figure with two dots to either side of its “torso.” Found worldwide, the most common forms are early American Indian versions.

Native American Indian “Squatter Man” Petroglyphs

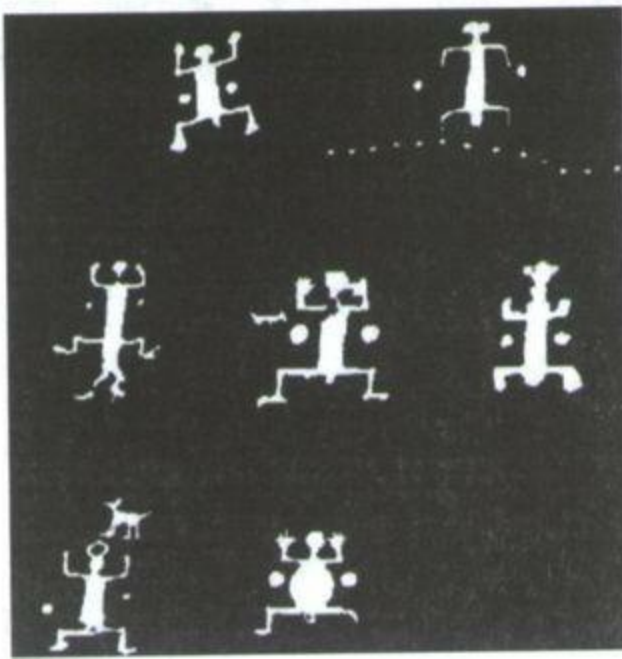

Such nomenclature, assigned to these pictographs by anthropologists who could view such cultures as nothing other than “primitive,” may have missed the point entirely, according to Peratt, for they may be indicative of a columnar plasma instability, indeed, bear an uncanny resemblance to it.

Peratt’s Comparison of a Three-Dimensional Plasma Instability on the Left, with its Two Dimensional Analogue on the Right (photos found on p. 22 of Talbott and Thornhill’s Thunderbolts of the Gods)

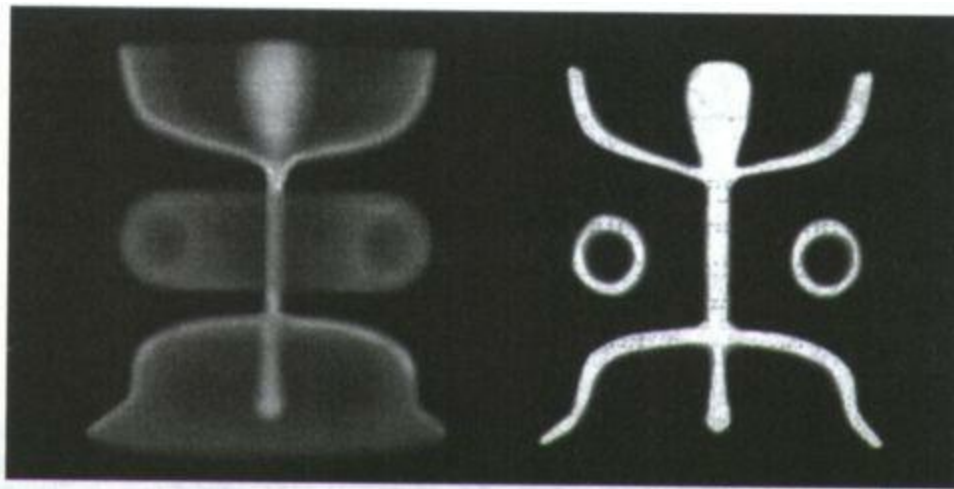

As the above comparison indicates, the “Squatter Man” petroglyph may be nothing more than the recorded two dimensional observation of a vast auroral display, with the two dots to either side of the torso representing the various toroidal forms such instabilities may take.

Yet another such comparison is the “stacked torus” columnar instability seemingly indicated by yet another petroglyph.

Pictograph from Kayenta, Arizona.

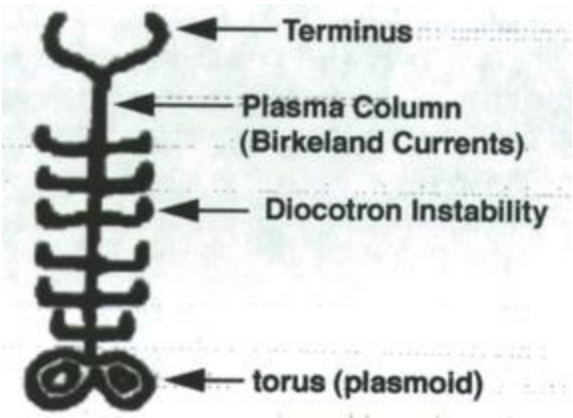

As the above interpretation of Talbott and Thornhill indicates, this petroglyph, from an American Indian site at Kayenta, Arizona, not only gives another verifiable connection to plasma physics but also demonstrates that “primitive” man may not have been as primitive as we have been led to believe, but was an *accurate* recorder of phenomena and events he witnessed. This highlights a very significant question, for if these ancient human observers were accurate recorders and observers of such phenomena in their myths and art works, why would one argue, as catastrophism does, that they accurately record such awesome celestial displays, and yet dismiss them as mere metaphor-makers or inaccurate recorders, when those same cultures often indicate that such displays are the result of the wars of the gods, fought with weapons of lightning and stones? We will return again and again to this point throughout this work.

Three Dimensional Model of the Kayenta, Arizona Petroglyph: Stacked Plasma Toroids

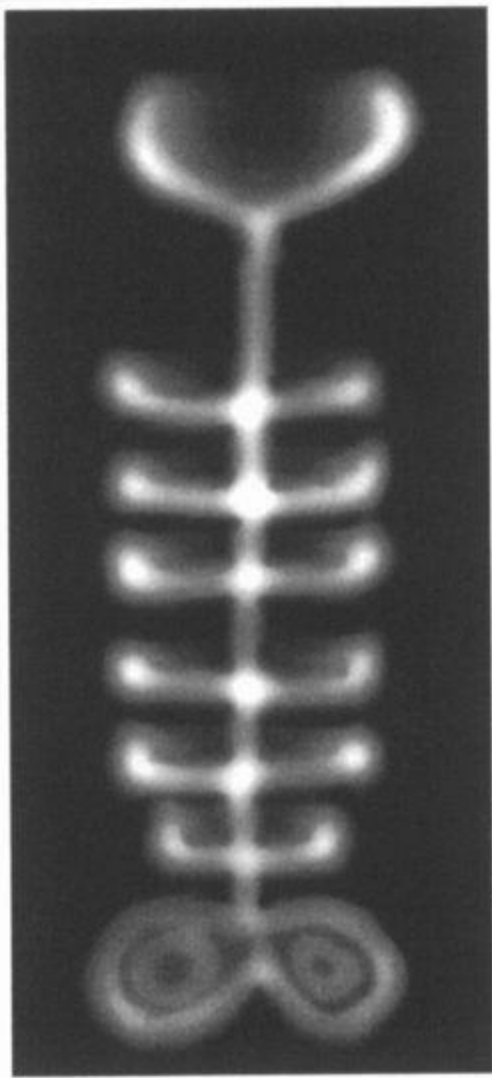

Other Petroglyphs of Stacked Toruses

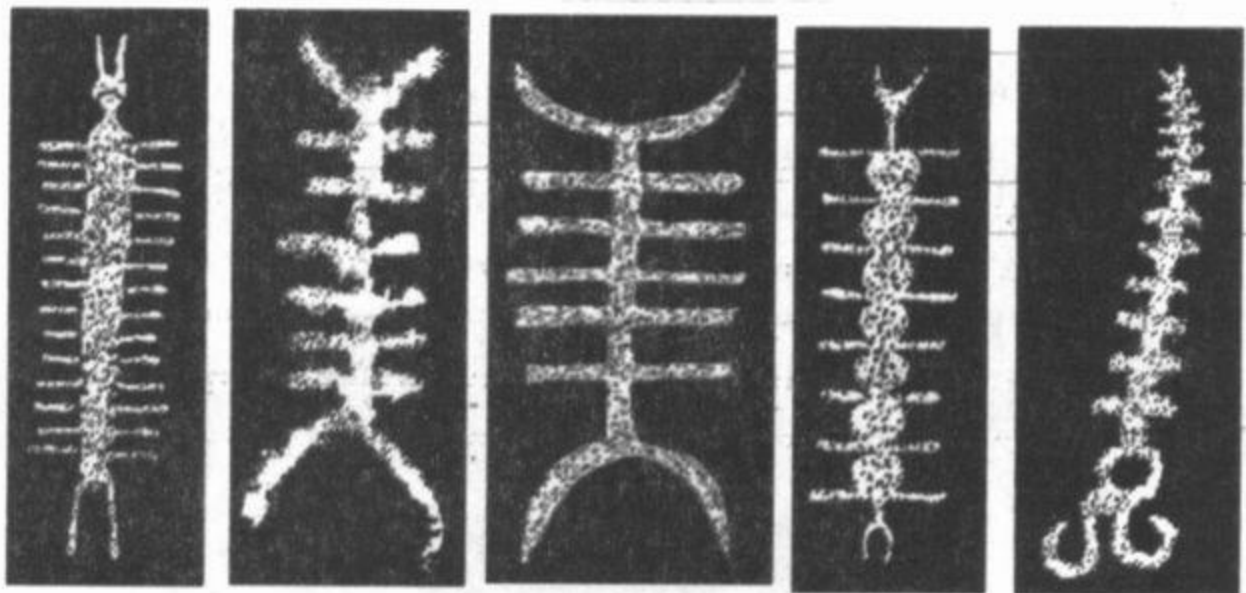

C. The Divine Weapon

One of the most intriguing comparisons of Peratt's plasma instability geometries and ancient depictions comes not from Peratt, but from Talbott and Thornhill themselves. Using the following depiction of the "divine thunderbolt" of the Babylonian god Ninurta, as commonly depicted in ancient art, they compare it to an astonishingly similar model of a plasma discharge in the laboratory.

Ninurta with Thunderbolts



Ninurta's Divine Weapon and Plasma Discharge Compared (From p. 52 of Talbott and Thornhill's Thunderbolts of the Gods)

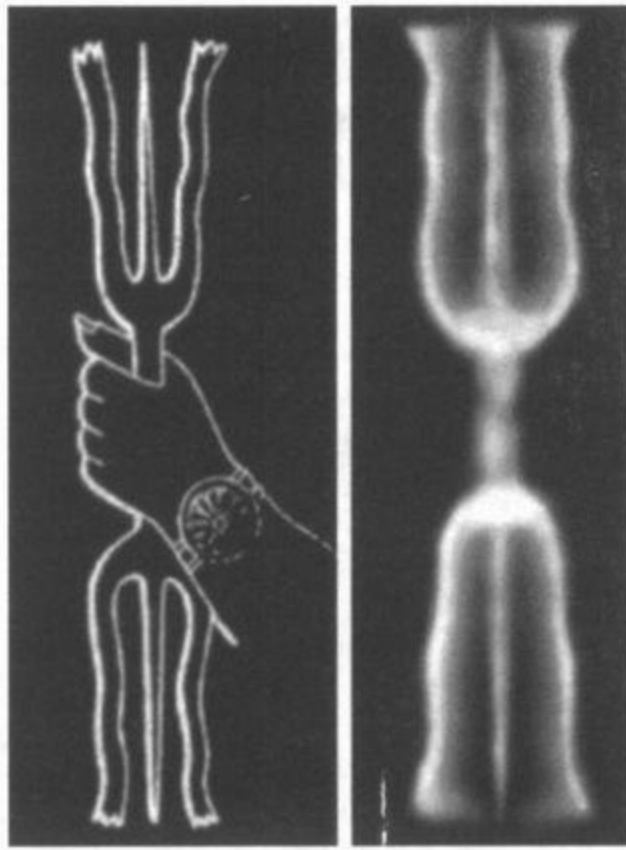

Moreover, the comparison is not confined to Babylonia. The various Greek depictions of the “thunderbolts of Zeus” bear similar artistic depictions of the same plasma geometry:

Various Greek Depictions of the Thunderbolts of Zeus (From p. 53 of Talbott and Thornhill’s The Thunderbolts of the Gods)



An even more thought provoking comparison may be made of multi-tailed “pitchfork” Greek depictions of this thunderbolt, and similar laboratory generated plasma discharges:

Multi-Tailed Greek Thunderbolt “Pitchforks” (From p. 53 of Talbott and Thornhill’s Thunderbolts of the Gods)



“Pitchfork ” Plasma Discharge in the Laboratory (From p. 55 of Talbott and Thornhill’s Thunderbolts of the Gods)

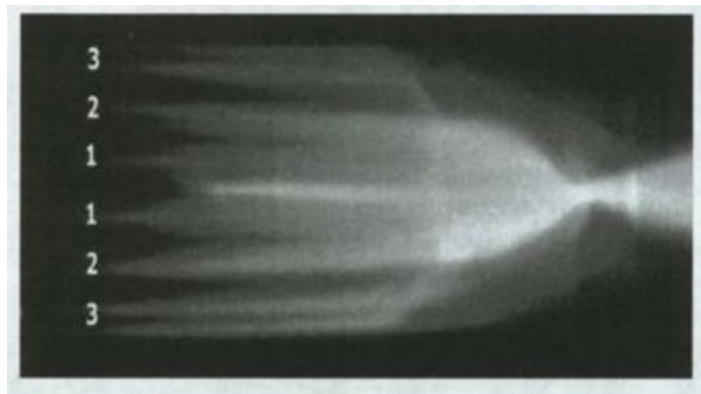

While the above is but a small sample of the many fascinating comparisons drawn by Peratt, and by David Talbott and Wallace Thornhill in their excellent study *The Thunderbolts of the Gods*, it should suffice to demonstrate that plasma physicists have taken the paleophysical examination of ancient art to new and detailed - and in Peratt’s case, scientifically peer-reviewed - levels.

D. Evidence of Planetary Sized Discharges in the Solar System

In addition to all the foregoing considerations, there is evidence that various bodies in the solar system have suffered huge electrostatic discharges, scarring their surfaces. Such massive discharges may have been large enough to just barely be seen from Earth by man. One class of evidence that should be considered are so-called “rilles” which in mainstream planetary geological theory are the result of brief releases of running water, or, in some cases, lava. While such channels can indeed be created by such means, there are rilles that show evidence of creation by the mechanism of gigantic lightning strikes. One such rille is the Hyginus Rille on Earth’s nearest neighbor, the Moon.

Hyginus Rille on the Moon



Notice the circular “pits” in this rille. Such pits, according to physicist Wallace Thronhill, are a typical characteristic of channels created by massive electrostatic discharges.^{[113](#)}

One of the moons of Jupiter, Europa, shows even more dramatic evidence of massive discharges, displaying a typical feature of the “corkscrew” effect of plasma filaments.

Corkscrew Discharge Pattern on Jupiter’s Moon, Europa

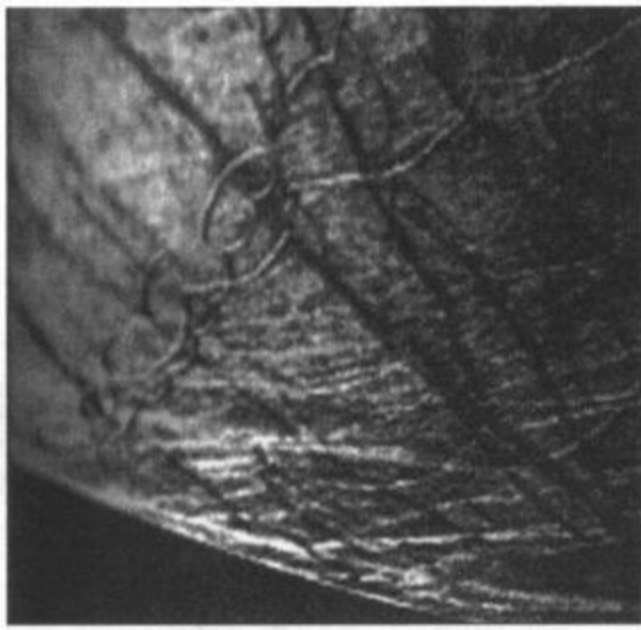

Wallace Thornhill's characterization of this type of evidence may be summarized as follows, noting the comparison of craters on planets and moons with those created by electrical discharge in the laboratory:

Both tend to be perfectly circular because an electrical arc always strikes perpendicular to a surface. Walls are nearly vertical and floors are nearly flat as the circular motion of the arc machines out the crater. Impact and explosion craters, by contrast, tend to have a bowl shape: Instead of being lifted from the surface, excavated material undergoes shock displacement, shattering and flowing in a manner similar to that of a fluid for the duration of the shock.

Another common feature of electrically generated craters, Thornhill explains, is terracing along the sides, sometimes corkscrewing down to the floor, following the rotary motion of the arc. The Moon and Mars both provide many examples of terraced and corkscrew craters.¹¹⁴

These considerations indicate that at one time the solar system was far more electrically active than it is now.

But perhaps the most important - and from the standpoint of an actual *war* having been the cause of such scarring - a significant piece of evidence for this planetary-wide scarring by massive electrical discharges lies on Earth's closest neighbor, Mars, in the gigantic Valles Marineris, a huge canyon some four thousand kilometers long, up to seven hundred kilometers across "in some places, and up to six hundred kilometers deep." Nor is this the only mystery to this highly anomalous planetary feature. "Approximately two million cubic kilometers of the Martian surface was removed with no comparable debris field apparent."¹¹⁵

Valles Marineris on Mars: Scarred Evidence of a Massive Electric Discharge

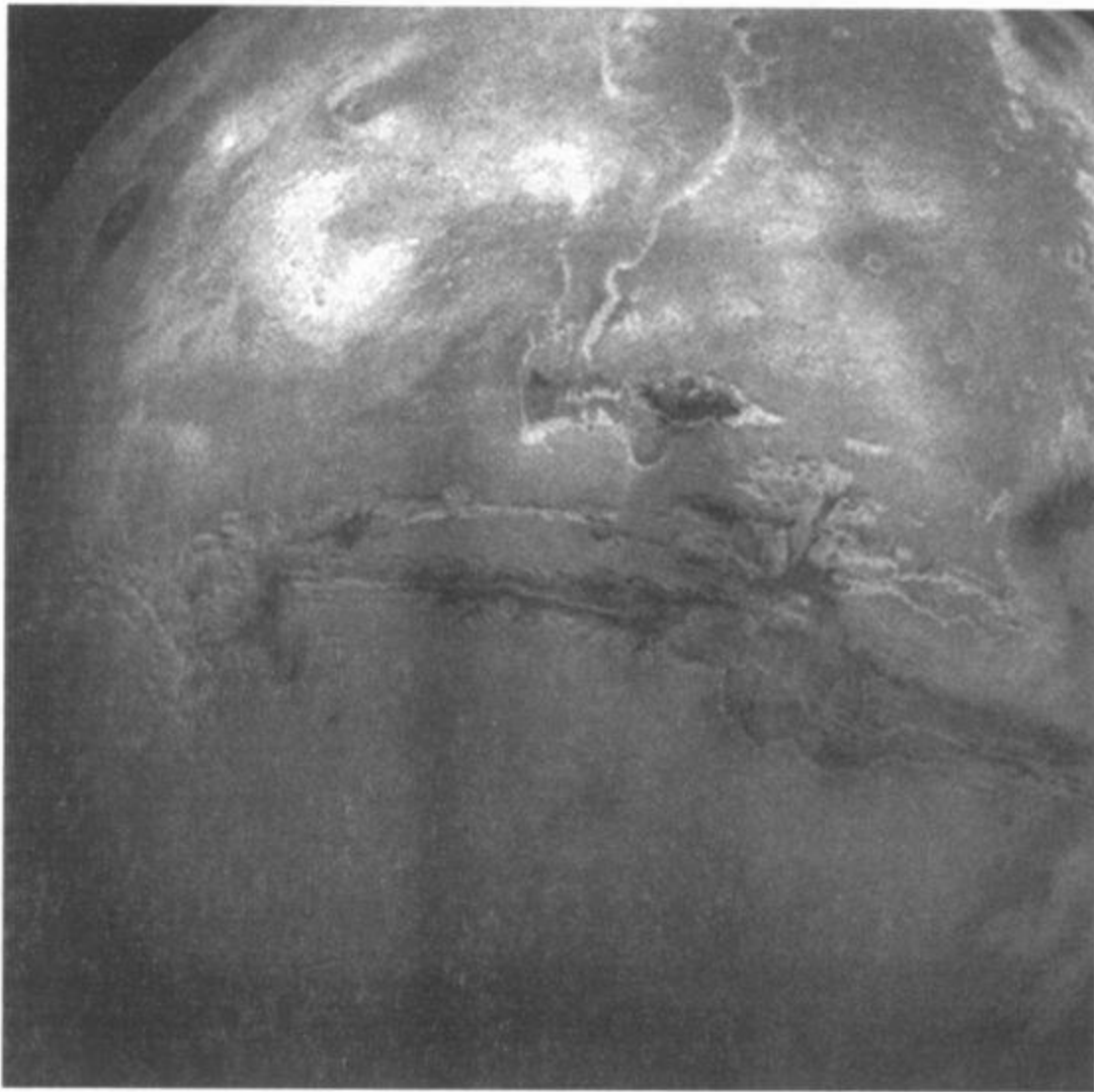

This is not, however, the only thing unusual about the Valles Marineris.

Wallace Thornhill was first contacted by comparative mythologist David Talbott, who, investigating an ancient theme of classical mythology and knowing of the Valles Marineris, decided to get in touch with the physicist. What Talbott had noticed was the “Scarface Motif” of some ancient myths. This motif, common to many cultures, is one of a “warrior-god, who, at a time of upheaval, receives a gaping wound or scar on his forehead, face, or thigh.” But it would be a mistake to see it as a merely “personal” wound inflicted on some mythological hero. It is, rather, the wound associated with the “celestial *archetype* of warriors - the god whom human warriors celebrated as their inspiration on the battlefield. In early astronomies, this warrior archetype is identified with a specific planet - Mars.”¹¹⁶

Talbott immediately asked a significant question, raising the “Problem of Peratt” yet again, and in yet a different form: was it just possible that

The “wounding” of Mars refers to an actual event? “I remember looking at one of the first Mariner photographs of Mars,” Talbott recalls. “It displayed a stupendous chasm cutting across the face of the planet. Even from a considerable distance, the chasm looked like a scar.... At that moment I realized that of all the planets and moons in our solar system, Mars alone bore the

likeness of the warrior-god's wound.”¹¹⁷

Behind the myth, in other words, lay a very real event: science and mythology were converging at the very place mythology — if taken seriously from a paleophysical perspective — said it would: Mars.

The wound of the warrior-God, Ares, the Greek's Mars, was real.

But this immediately provokes two questions, the first of which was asked by Talbott himself:

1. “Could something as massive as Valles Marineris have been carved by interplanetary lightning?”¹¹⁸
2. Did someone - humans or otherwise - actually *observe* the event from Earth or elsewhere, and *record* the event?

While the first question indicates that one feature of Talbott and Thornhill's hypothesis is that these discharges are evidences of gigantic, solar system wide interplanetary “arcing” from a time when the solar system was very young and electrically dynamic, it is important not to lose sight of the question itself: could such a geological feature, massive as it is, be carved by electrical discharge? “Could Valles Marineris have been caused by a thunderbolt?” Talbott asked Thornhill.¹¹⁹

Thornhill replied, “It couldn't have been anything else.”

“...Valles Marineris was created within minutes by a giant electric arc sweeping across the surface of Mars,” Thornhill claims. “The rock and soil were lifted into space. Some of it fell back around the planet to create the great, strewn fields of boulders seen by both Viking Landers and Pathfinder.”¹²⁰

The “mighty chasm” of Valles Marineris thus “represents the confluence of two worldviews: the dramatic, historical worldview of mythology and the objective, physical worldview of science.”¹²¹

If that is so, however, it raises the second question in no uncertain terms. How is it that ancient mythology, art, and petroglyphic symbols can preserve the legend of planetary scarring, can accurately record the very shape of complex plasma filaments, of stacked toruses, intertwining currents, and of plasma pinching effects?

There are only three real possibilities:

1. The ancients possessed a plasma cosmology and physics themselves, and from laboratory experiments, were well familiar with the patterns exhibited by Peratt's petroglyphs. They chose, for some strange reason, to disguise their knowledge by creating myths and legends in archaic petroglyphs and mythological symbols. But this implies a *technology at least as advanced as our own in order to create plasma effects of the type observed to begin with.*
2. Someone *else* possessed all these things, and actually transmitted this knowledge to ancient man, who subsequently embellished the basic conceptions with mythological hyperbole.
3. Ancient man actually *observed and more or less accurately recorded what he saw in myth,*

artistic symbol, and in the petroglyphs.

Regardless of which version one opts for, one is left with another disquieting aspect of “The Problem of Peratt,” and that is, that whatever catastrophes as ancient mankind appeared to witness and record in his art and mythological archetypes, the catastrophes witnessed *appear to fall outside the chronological parameters both of Van Flandern’s Exploded Planet Hypothesis and Hannes Alfvén’s electrically dynamic solar system, for in both cases the events or conditions described in those hypotheses happened some millions of years ago.* Yet the artistic symbols, the myths, and Peratt’s petroglyphs themselves are all only *thousands* of years old.

Any way one slices it, various sciences are involved in the contradiction, in the *problematic* inherent in the “Problem of Peratt,” for on the one hand, if humans observed these events, then either the described events are much more recent than the two physics theories that can account for them will allow, or mankind is of far greater antiquity than contemporary paleontology, anthropology, and historical theory will allow.¹²² In the latter case, an additional problem arises, for it would imply that mankind preserved his artistic and mythological archetypes with amazing consistency and accuracy over several million years.

It is this accuracy of the artistic record - of the petroglyphs and ancient art work depicting the “divine weapons” by capturing the subtleties of plasma discharges - that is itself problematic for the catastrophist view, espoused most brilliantly by scholar Alan Alford as we shall see in the next chapter, that would then in turn maintain that all mythological references to the Wars of the Gods are but metaphors for an exploded planet cult. If that were so, why did the ancients, who were certainly *capable* of depicting planets as circular orbs, not depict them as such? Why give them arms and legs and faces and beards, and thunderbolts that are amazingly accurate depictions of electrical plasma phenomena? And why give the gods not only the technology for such massive displays of power, but ascribe to them personalities and motivations to use it?

Why indeed, unless they are describing *real events* in a *real war*.

E. Conclusions

Whatever one makes of the above questions and considerations, a number of important things have emerged in the investigation thus far.

1. Plasma discharge phenomena can account for the vorticular geometry of entire galaxies as well as phenomena that can be simulated and reproduced in a laboratory.
2. These phenomena may be accessed in part by the technology of a plasma focus device, which exhibits both peculiar anti-gravitational “electro-gravitic” effects as well as weaponizable effects, from fusion, to explosion, to streams of high energy negative and heavy ionic radiation.
3. Such plasma phenomena additionally appear to be intricately linked to even more fundamental scalar physics properties via the non-linear and rotational properties of plasmoids. Given that such plasma phenomena may be accessed by technology, as in point 2 above, it is then conceivable that the phenomena may be coupled to or accessed at a celestial scale, and weaponized at that scale.^{[123](#)}
4. Celestially scaled plasma discharge phenomena appear to have been recorded, if not witnessed, by ancient mankind in a variety of mythological symbols, petroglyphs, and legends.
5. In certain cases these myths actually point to the planet Mars, ancient “god of war”, as being the central location for some of these phenomena.^{[124](#)}

One has with plasma phenomena, on the one hand then, a physics sufficient to the task of significantly scarring, if not exploding, a planet, a basic technology in the plasma focus that can access some of the most significant phenomena of plasmas, and on the other hand a mythological tradition that clearly and unequivocally maintains that this physics was once accessed, used in a war for the deliberate destruction of one or more planets, and for the massive scarring of the surface of another, leaving its collateral damage strewn throughout the solar system.

It seems to me that there might be a fundamental difficulty with plasma cosmology, and this is its maintenance that vast electrical-plasma filaments connect and bind together whole galaxies in galactic clusters. But such bonding could only occur at the velocity of light, and would therefore seem insufficient as a basis of their bonding. Something else must therefore be transferring information between galaxies in order to form these clusters in such a way that the filamentary connections of galaxies emerge as its signature. Thus, extending this speculation a bit further, it might be that the phenomenon of galactic clusters and their filamentary bonding is a large scale version of photon entanglement, and a very large demonstration of the non-local nature of the medium. In this, then, plasma cosmology would seem to point to an even deeper physics, which we have followed Bearden in calling “scalar” physics. As this chapter has averred, the connection between the two models is quite strong.

But why would ancient mankind employ such a diffuse and complex symbolism to convey all these things? And when broken down to its basic motifs, what constitutes the various layers of that

symbolism? As will be seen in the next chapter, the second question is actually the means to answer the first...

3.

THE CATASTROPHE OF CATASTROPHISM

“A torrent of large stones coming from the sky, an earthquake, a whirlwind, a disturbance in the movement of the earth - these four phenomena belong together. ”

Immanuel Velikovsky^{[125](#)}

“In the exploded planet, then, we have a primary ‘Myth of all myths’ which was not only extremely profound, but also, allegedly, true. ”

Alan Alford^{[126](#)}

A. The Catastrophist Problematic

Ever since Immanuel Velikovsky first wrote his classic masterpiece *Worlds in Collision*, catastrophism has been the dominant model in the paleophysical interpretation of ancient myths. Indeed, Velikovsky's book was perhaps the first real attempt to *do* what I call "paleophysics," that is, an examination of ancient mythological texts and legends for the possibility that they encode scientific, physics related knowledge and a comparison of that knowledge with existing scientific theory. Velikovsky's goal was, for all that, not scientific but historical, for he sought to illumine overlooked areas of cosmological history. Nonetheless, his works - notwithstanding the outcry against them from a scientific priesthood locked into its own astronomical dogmas - struck an elegant balance between science and history that has not been exceeded by any, and equaled by none but a few.

Where Velikovsky earned - even if undeservedly - the ire of the "scientific" community was his use of the ancient mythological texts to make scientific predictions and to formulate new scientific hypotheses, the two most famous being his assertion that Venus was once a large comet, and that the solar system was not electrically neutral. As physicist Anthony Peratt and others in the plasma physics school have amply demonstrated and ably argued, the latter hypothesis appears to have some support within contemporary thinking. So whatever one makes of Velikovsky's hypothesis that Venus was once a comet, he stands at least partially vindicated. And if the work of Clube and Napier and others regarding meteor and comet impacts and near misses, or if Van Flinders's Multiple Exploded Planets hypothesis is considered, then even Velikovsky's former hypothesis appears partially vindicated as well: comets can, and moreover, did, wreak untold destruction in the solar system *subsequent* to the initial planetary explosion. But the problem of explaining that *initial* explosion remains.

What Velikovsky discerned, in ancient legends spanning the globe from the Mayans to the Hebrews, was a discernible *pattern* of celestial, cosmic catastrophe that had dire consequences for the earth's life, climate, geography, topography, and even its own celestial mechanics. His examination of these mythological traditions led him to observe "A torrent of large stones coming from the sky, an earthquake, a whirlwind, a disturbance in the movement of the earth - these four phenomena belong together."¹²⁷ But it was what Velikovsky discerned as the cause of these phenomena that gave birth to a whole new school of reading such ancient texts and interpreting them as containing elements of science:

It appears that a large comet must have passed very near to our planet and disrupted its movement; a part of the stones dispersed in the neck and tail of the comet smote the surface of our earth a shattering blow.¹²⁸

These words gave birth to a whole new school of mythological interpretation - catastrophism - and one need only replace the word "comet" in the above quotation with "meteor" or "asteroid" and one will have its contemporary version.

Many have followed in Velikovsky's footsteps, but none is more capable nor as broadly read as is

Alan Alford, who is perhaps the most learned and articulate spokesman for this school.

1. *The Interpretive Paradigm of Alan Alford*

Alford's case for catastrophism is ably set out in three masterful tomes: *The Phoenix Solution: Secrets of a Lost Civilisation*, *The Atlantis Secret: A Complete Decoding of Plato's Lost Continent*, and perhaps the most important study of the three, *When the Gods Came Down: The Catastrophic Roots of Religion Revealed*. Indeed, as the last title reveals, Alford's intention is somewhat different than Velikovsky's, though both men consult a similar range of texts. Whereas Velikovsky aims merely at explaining a broad cosmological history in terms of the physics that his texts suggest, Alford's aim is narrower, seeking to explain the *origin* of those myths and texts, *and the religions based upon them*. In other words, for most catastrophists, the paradigm is used to explain certain types of physical evidences, and certain types of statements in texts, on the basis of physical theory. In a new twist on philosophical naturalism and materialism, however, Alford uses the catastrophist paleophysical paradigm to explain the origin of religions and certain types of expressions in religious texts themselves.

This caveat notwithstanding, it is safe to say Alford's works constitute the most scholarly and well-researched continuation of the catastrophist paradigm of mythological interpretation since Velikovsky first gave it textual flesh and bones. Here our concentration will be on his *Atlantis Secret and When the Gods Came Down*, for it is in these works that he makes the most sweeping claims for the interpretive power of this paradigm. Indeed, in *The Atlantis Secret* Alford is quite explicit about the universal explanatory power that he claims for his version of catastrophism:

In this book, I present not only a complete decoding of the lost continent of Atlantis, but also a complete decoding of ancient Greek religion in its entirety. I am able to decode the myths of the Olympian gods and their associated mystery cults; I am able to decode the myth of the golden age and the fall of man; I am able to to decode the scientific cosmogonies of Thales, Anaximander, Heraclitus, Anaxagoras, Empedocles and Philolaos; I am able to decode the 'soul religion' of Orpheus, Pythagoras, Parmenides, Socrates and Plato; and I am able to decode Plato's Theory of Forms, his account of creation by the *Demiourgos*, and his story of Atlantis. *Behind all of these ideas there lies a single secret of stunning simplicity - the age-old myth of exploded planet.*

[129](#)

In other words, behind all the complex imagery and themes of the Greeks, behind all their arcane and well-reasoned philosophy, behind all the arcane rituals of their mystery schools, lies one simple concept

for which they are *all* metaphors and allegories: *all* of it is but "the age-old myth of the exploded planet."

But lest one think that the catastrophist paradigm is restricted merely to the Greeks, Alford pointedly states that the same applies to the other religions of the region: "The religions of the ancient Near East are best described as 'exploded planet cults,'" [130](#) even, as we shall see, Judaism and Christianity in their very core doctrines. Lest one think that Alford is unaware of the sweeping nature of his claims for the universal explanatory power of the catastrophist paradigm, he spells it out

explicitly:

- The exploded planet was invisible by nature, thus explaining the ancients' worship of visible substitutes - meteorites, statues, fertility-gods, weather-gods, Sun, Moon and stars.
- The worship of the gods in anthropomorphic form was an entirely predictable offshoot of the exploded planet cult.
- The exploded planet cult was as profound as profound gets, involving the death of a living planet and the rebirth of life on another planet - the Earth. There is no need to suppose any deeper, hidden meaning to the ancient myths.
- The mythical (Exploded Planet Hypothesis) is entirely separate from the scientific (Exploded Planet Hypothesis) and does not require the actual explosion of a planet. There is no law that requires ancient religious beliefs to be scientifically true.¹³¹

However, it is this last point that highlights the problematic inherent in Alford's version of catastrophism, and indeed inherent in most catastrophist interpretations of ancient myths, and that is, if the texts are *not* to be correlated with any scientific theory - ancient or modern - of an exploded planet in nearby space, then how and why would the ancients, across such a broad diversity of cultures and dispersion of this one theme, hit upon the idea in the first place? And if this scenario is, as Alford says, "one of a ... world that was once saturated with the cults of numerous exploded planet deities, each personifying exactly the same idea, but expressed in a variety of different ways,"¹³² then why employ such a confused jungle overgrowth of symbols to portray it? The ancients, on Alford's problematical view, were obsessed across cultures and religions with this one idea to such an extent that this obsession itself must be explained. As will be seen, this, too is another problematic inherent in Alford's approach.

a. Chimeras as Meteorites

Alford produces a veritable blizzard of thematic motifs and references in his books in support of his contention that most if not all such motifs refer to the "hidden" truth of an exploded planet. A basic formula, however, underlies all the motifs he explores in his works, and that is that anything referring to mountains, cities, or islands in the "sea" or "the deep" is a metaphor for a planet, which is an "island" or "mountain" in the midst of the "deep" or "sea" of space.

This formula has a corollary: anything chimerical or of a "hybrid" nature, particularly if it involves a heavenly component and an earthly one - the *Nephilim* or "sons of God" who sired chimerical giant offspring with human women in the Old Testament for example - is a *meteorite*, since a meteorite, as a remnant of the exploded planet, has both a heavenly component since it fell from heaven, and an earthly one, since it fell to, and in some cases, penetrated under, the surface of the earth.

Accordingly, as Alford explicitly states, "it is worth mentioning that even the Sphinx - a supreme solar symbol in the eyes of Egyptologists - was actually an exploded planet symbol."¹³³

b. Giants and Titans as Meteorites

Similarly, even the hero of the Babylonian epic *Gilgamesh* becomes a similar symbol, for as the epic itself states, “Two thirds of him is god and one third of him is man.”¹³⁴ Since Gilgamesh was also a “giant” according to the Babylonian epic, the meaning of the symbol thus becomes crystal clear for Alford:

Once we marry up this information with the other legends of Gilgamesh’s Titan-like birth, together with the fact that the senior gods were *exploded planets*, it becomes evident that the “flesh of the gods” was the meteorite efflux of the gods. The name Gilgamesh, then, meant “*meteorite...*”¹³⁵

So far so good, but the reader may perhaps have already detected a difficulty with Alford’s methodology: there are no external controls or checks on it. Once his basic formula is unleashed on mythological texts, anything fitting its general parameters becomes a symbol of the catastrophism of an exploded planet.

c. Planetary Collisions as Wars

Thus, when ancient mythological texts speak of the “wars” of the gods, they are speaking of the “collisions” of celestial bodies, notwithstanding the fact that not all ancient texts can be construed as collisions between objects. In other words, while it is certainly true that some ancient texts speak of divine “arrows” and “stones” or “missiles” being used to slay some divine opponent, not all war references include these types of weapons. Just as often mythological texts speak of the “lightning” or “bolt” of the gods, and even the theme of “divine arrows” could be a metaphor for lightning discharges. Thus, Alford’s formula begins to show a subtle crack. Nonetheless, there is a consistency with which he applies it, for the “children” of the “gods” then become the meteors and asteroids that crash to the earth.

For example, the “‘people’ who came forth from the womb of the goddess Ishtar were not really ‘people’ at all - *they were the meteorite offspring from an exploding planetary body.*”¹³⁶

d. The Ultimate Reductio

Alford’s catastrophism knows no bounds. Even “Noah was not a man but a god - a fallen meteorite.”¹³⁷ And if that were not enough, Alford reaches his ultimate *reductio ad absurdum* with the following passage:

How would the Church explain the fact that Jesus Christ was originally a physical flood o:

meteorites?

And, if this long-hidden-aspect of Jesus Christ was revealed, how would the Church explain the role of Jesus-the-man from the 1st century AD? Would the Church admit that Jesus-the-man was an actor in a Mystery Play or Passion play? Would the Church acknowledge that the crucifixion was in fact an ingenious esoteric parable for the death of a planet?

The mind absolutely boggles at the thought of all this. [138](#)

Yes indeed, the mind truly *does* boggle at the thought of all this, for it would seem that, following his well-footnoted formula with the absolute devotion of a fundamentalist, one can interpret literally *all* mythological references or religious texts in such a manner as to construe it as referring to nothing more than an exploded planet.

But - if I may be permitted to paraphrase the Christian apologist C.S. Lewis for a moment - to see through everything is to see nothing at all; there must be *some* opacity to the text.

Thus, how would Alford explain the fact, referred to in my book *The Giza Death Star Destroyed*, that these same planets-as-gods then go on to sire very *human* offspring and teach them the various arts and sciences necessary to civilization, as those very same texts, across several cultural traditions, attest? Alford's answer is to maintain that this meteoric bombardment seeded the earth with life which then evolved, via the familiar mechanisms of "evolution," into mankind.

So how does one answer someone like Alford?

Very simply.

If all the textual references to giants, titans, Nephilim, Anunnaki and so on are nothing but cleverly concocted metaphors for an exploded planet, and thus *not real*, then one should never be able to find any evidence or ancient artifact of intelligent life on nearby planets, nor any evidence of giants, titans, and such on earth. If, however, such things are found, then by the very nature of the sweeping and universal explanatory power that Alford claims for his "method" of interpreting the texts, these things would constitute loose corroboration of my own reading of the texts, and the fatal "exception" to Alford's claims, for to claim universal validity and powers of explanation is to claim no exceptions. We shall turn to the evidence for the existence of ancient giants in the next chapter.

e. An Intriguing Formula: Gods Equal Mountains Equal Planets

Here we shall concentrate on the implication of the discovery of ancient extraterrestrial *artifacts* of intelligent life for Alford's hypothesis, by focusing on the significant, and truly important and *legitimate* insight that Alford makes regarding the equation "mountains equal planets equal gods." Referring to the fact that Mesopotamian texts often refer to the god Enlil as "the Great Mountain" who engenders the four seasons, Alford then makes the following insightful observation: "It must be said that the idea of summer and winter being engendered upon a 'mountain' only makes sense if the

‘mountain’ in question was the entire planet of Earth.”¹³⁹ Thus one arrives at a significant formula that guides Alford (and as we shall see in later chapters, contains another constant or variable that Alford does not take into account). That formula is, once again, “mountains equal planets equal gods.” And I mean the word “equals” here in its entire logical and ontological significance; if “a” equals “b” and “b” equals “c”, then by the laws of logic and commutivity, “a” equals “c”.

B. A Return to the Catastrophist Problematic

Is this formula true? Or has Alford misconstrued *close association or approximation* in the texts of those three components with *equality and identity*? Is the formula this:

Mountains \equiv planets \equiv gods,

where “ \equiv ” means “is identical to”, or this:

Mountains \approx planets \approx gods,

where “ \approx ” means “is closely associated with”?

If the latter, then the three things, while closely related in the text, remain distinct, requiring not the reduction of various levels of meaning in the texts to one prosaic and materialistic level, as with Alford’s formula, but rather the careful unpacking of several intertwined levels of meaning. This brings us to something I discussed briefly in my book *The Giza Death Star Destroyed*:

1. *The Unified Intention of Symbol*

To understand how the difference in formulas works, and to understand how the formulas require some external check or grounding, let us return to the plasma cosmology and the observations of physicist Anthony Peratt and the ancient petroglyphs.

While Peratt's interpretations of petroglyphs as symbols of plasma stabilities and instabilities are compelling, and give new weight to the plasma cosmology from the paleographical context, there is a significant problematic, which presents itself in two fundamental ways: (1) a cosmological and physics component, and (2) a textual component.

The cosmological and physics component may best be examined by noting one implication of the "catastrophist" interpretation of plasma cosmology, for during the age of the "interplanetary discharges," a very different picture of celestial mechanics would have been necessitated:

According to Talbott, what the ancients worshipped and feared as powerful *gods* were *planets positioned extremely close to the Earth. This close congregation of planets appeared as huge powers in the sky. Their instabilities and unpredictable movements gave rise to one of the most common themes of myth - the wars of the gods.* In these dramatic stories, the gods pounded each other with cosmic lightning while fire and stone descended on Earth.¹⁴⁰

This is as succinct a statement of both aspects of the problematic as one could wish for.

In it, one encounters the familiar catastrophist theme of the interpretation of the names *of gods* as metaphors for *planets*. But note the implication of this interpretation for the rest of the textual evidence of ancient mythologies, for the metaphor "bleeds into" that of the "wars of the gods," a common theme in ancient myths. As I noted in my book *The Giza Death Star Destroyed*, this would be a plausible interpretation were it not for the fact that many of these same mythological cultures then continue the "story" by having these gods marry and sire, or mother, children.¹⁴¹ This too, as I noted there, would be capable of a plausible catastrophist interpretation were it not for the fact that these children, through similar marriages, eventually become the ancestors to very real, very human, flesh and blood ancient kings. In other words, the metaphor was "mixed" in the very worst fashion, reminiscent of the most hackneyed and clumsy schoolboy compositional exercise. So much, for the moment, for the "textual" component of the problematic.

What is of great significance is the cosmological component alluded to, for as is clear, in the standard electro-dynamic plasma cosmology view of these "wars", the planets were once, in the very distant past, much closer to each other and therefore much more electrically active and unstable. And this highlights the difficulty, for if this were the case, then what mechanism would have led from this initial chaotic condition to the condition of the relatively stable celestial mechanics in evidence now? More importantly, what process of extrapolation, from the observable existing "stability" of the local celestial system backwards to the paleoancient chaotic one, could have led the myth makers to such an exact and apparently accurate description of these ancient events? Talbott and Thornhill state this problem in the following way:

How stable was the solar system in the past? In the pioneering work of Hannes Alfvén and his successors, orbital instability is a virtual certainty in the long-term evolution of an electrical model. In the birth of stellar and planetary systems, the electric force will typically dominate. But as the system dissipates electrical energy, it will reach a transitional phase at which a shift toward gravitational supremacy will occur, with potentially violent consequences. A chaotic system will then move toward stable electrical and gravitational equilibrium. Once planets achieve predictable orbits, no computer simulation based on later motions of the planets can provide even a clue as to the earlier system or its disruption.¹⁴²

In answer to this problem, we are left with two choices: (1) either the celestial science of the ancients was considerably more advanced than we realize, such that it possessed such a theoretical model that allowed such extrapolations to be made, a thesis that, if true, would make their science much more advanced than our own; *or* (2) human myth-makers were telling stories that they had *received*, and ultimately the events that the myths described were therefore *observed* by intelligent entities (and/or mankind) and passed down to subsequent humanity.

This last possibility raises two further, and equally important, and equally problematic questions. Either the events were (1) observed by *humans*, or (2) were observed by *non-human intelligent life* (either in conjunction with human observers, or not) and then subsequently communicated to man. The first is problematical for the simple reason that it implies an antiquity and *cultural sophistication* for humanity quite at variance with standard academic theory of the biological and cultural evolution of mankind, since the events described would be on the order of millions if not billions of years old. The second is problematic for a similar reason, and additionally so, for it implies an “interventionist” origin for human culture, and perhaps for humanity itself. But additionally, it is problematic for the simple reason that *this interventionist view is what most of the ancient myths themselves state!*

The two components of this problematic - the cosmology-physics and the (con)textual - are not unrelated nor even loosely so, for lacking a plausible *physical* model of celestial mechanics that could bridge the gap between the paleoancient “chaos” to the present “order”,¹⁴³ the texts and mythical traditions themselves indicate the answer to this question in no uncertain terms, for a *real war* would be able to do just that.

But that, of course, implies real people to fight the war, and real weapons of truly cosmic proportions, to fight it with.

To appreciate the significance of the war scenario, one may refer to the chronological questions it both resolves and the new chronological questions it raises. On the one hand, if one takes the “war” scenario seriously, then there is no need to assume the “cosmic catastrophes” that the myths describe as having to do with the initial chaotic conditions of the entire universe. In other words, there is no need to push the events back into the remotest past of billions of years ago, during the electrically stormy period of the universe’s initial formation. Indeed, the “chaotic” conditions it describes need not indicate anything at all about the “normative celestial mechanics” of the period in which the events described occur, since such chaotic conditions could be *imposed upon the otherwise normal and regular celestial mechanics of any local solar system by a society possessed of a sufficiently advanced physics to do so, and a technology capable of weaponizing that physics*. Such physics, if it existed at all, could be imposed on any regularly ordered celestial system, including our own, thus

making it appear for the moment to be chaotic. We may therefore not be dealing with events that transpired some billions of years ago, but with events that occurred “mere” millions of years ago.

Once this highly speculative concept is entertained, it opens the door to a resolution of other chronological issues, for it allows the war to have occurred at any stage that such a society might have emerged. In short, and barring the consideration of other types of evidence for the moment, the door is open for the cosmic cataclysm to occur anywhere from millions, to mere thousands, of years ago. And as has already been seen from the evidence presented in this chapter, there are two loci around which a chronological resolution must be orbited: on the one hand, it must account for the existing planetary data of such a catastrophe, from the asteroid belt as remnants of a missing exploded planet in our solar system, to the electrical discharge scarring on the various moons and planets - most notably Mars - in our solar system. The evidence, in other words, *precludes that catastrophist interpretation which would see the myths as describing the chaotic conditions at the origins of the solar system. The evidence necessitates a much later dating, for once one adds intelligent observers into the mix to observe and record these events, one perforce cannot be dealing with the primordial conditions of the solar system.* As will be seen eventually, the petroglyphic evidence compiled by Peratt, and the textual evidence of the myths themselves, fix another terminus a few thousands or tens of thousands of years ago.

When these thoughts are seriously entertained, they lead to an almost inexorably inescapable conclusion: if one must take such texts and cultural traditions seriously when it comes to planetary cataclysm, as the catastrophists consistently maintain, then perhaps it is time to take the same texts and traditions equally seriously and consistently when they talk of the wars that caused the catastrophes in the first place, and when they refer to the motivations and consequences for those wars.

a. Further Considerations of The Unified Intention of Symbol

This raises the question of what is meant by “the unified intention of symbol.” Basically, I mean this terminology to indicate that the multi-leveled nature at which mythological symbols operate were *originally chosen and intended to operate in such a fashion by the creators of those myths.* The phrase means, then, the exact opposite of what one encounters in Alan Alford’s work. Where Alford would have us *reduce and identify* several symbolic motifs and implied layers of meaning to one layer of meaning - that of the exploded planet - the ancients employed individual symbols or motifs in constellations and arrangements designed to *unfold into* several layers of meaning.

In this respect it would be useful to review what I wrote concerning this very same subject in *The Giza Death Star Destroyed.*

What are we to make of all this textual ambiguity that permits of so many different, well-argued interpretations? One could maintain that each hypothesis remains open until more evidence is known, until such time as a determination may be made between them. However, it is my belief that this interpretive ambiguity is *intentional and original to the case,* the deliberate contrivance of some paleoancient “elite” to preserve knowledge. That is to say, it would appear that the gods’ names, lengths of reigns, genealogies and bloodlines, the record of an interplanetary war and resulting recurrent catastrophism, and paleophysical astronomical and

quantum and sub-quantum-mechanical “secrets” were all *deliberately combined in a densely packed, multi-leveled symbolism designed to convey accurate knowledge of all of these things simultaneously*. These densely packed symbols are a device to preserve simultaneously the bloodline records, the interplanetary war and the origins of the current structure of the solar system, the necessary astronomical, physical, mathematical knowledge (and, by implication, the technology) by initiates into the Egyptian mysteries who doubtless did not know the full significance of their own religious esoteric tradition. That the *texts* intentionally combine all the religious, cosmological and quantum mechanical data along with dynastic wars is itself a corroboration of the type of unified physics I believe the Great Pyramid itself attests to. The ambiguity results from their interpretation should come as no surprise.¹⁴⁴

I call this resulting, and *intentional* ambiguity the ‘Unified Intention of Symbol,’ since one of its implications is that the contradiction between the interpretation of *real war* and that of *naturally recurring catastrophe* is only an apparent contradiction.”¹⁴⁵

b. The Emergence of the Unified Intention of Symbol from the Analogical Method

One may easily see how this unified intentionality of the complex and interrelated layers of mythological symbolism might have arisen from the analogical habit of thinking of ancient cultures itself. Indeed, if that habit of thinking in turn arose out of the sophisticated physics of its paleoancient precursor Very High Civilization, then it is also relatively easy to see why the spiritual and physics components of those myths were blended almost from the start.

1. *The Paleophysical Hermeneutic: Catastrophe Metaphor vs. Real War*

With these thoughts in mind a comparison of catastrophism versus the “real war” hermeneutic (explanation) is in order.

Clearly, catastrophism and “real war” are both paleophysical interpretive paradigms, that is, they both attempt to make sense of ancient legends and stories by means of a comparison of the claims of those texts and the models of modern science. Here, however, catastrophism and “real war” diverge on a number of points.

For the “real war” hermeneutic, the texts only make consistent sense if taken more or less as asserting an underlying reality to the events described. In other words:

- (1) the war was real;
- (2) the people or “gods” who fought it were real;
- (3) these people had real motivations for doing so, i.e., there is an underlying social order that was threatened by some perceived enemy, and a political agenda was at work;
- (4) it was fought with real, and horrendously powerful weapons of mass destruction on a planetary scale, including, weather weapons; thus, the exploded planet hypothesis is used merely to explain *certain texts as a limited event*;
- (5) there were real winners and losers;
- (6) these people or “gods” in some cases prior to, in some cases during, and in some cases after the war, then initiated a contact with humanity and began to interfere in its affairs, to the point of siring and initiating human civilizations and their dynasties.

For the “catastrophist” explanation, however, especially as exemplified in the popular work of Alan Alford, the following interesting thing begins to happen:

- (1) the exploded planet hypothesis is used to interpret references to “wars of the gods” as a metaphor for colliding planets;
- (2) the exploded planet hypothesis is used to interpret references in texts to the unions or marriages of the gods as metaphors for colliding planets;
- (3) the exploded planet hypothesis is used to interpret the children of such marriages as metaphors for the debris of those collisions;
- (4) the exploded planet hypothesis is used to interpret references of mixed heavenly and earthly origins of people (e.g. Adam, or the Nephilim in the Old Testament) as meaning this debris fell to earth - in yet more planetary collisions and impacts - and seeded life on earth.

In other words, the catastrophist use of the exploded planet hypothesis - especially in the hands of an Alan Alford, becomes a way to view almost *every* textual theme in such legends as a metaphor of

what he calls “the exploded planet cult.” This is as true of Plato in his allegory of Atlantis, to the Hebrew priests who compiled the Old Testament, to the Sanskrit scribes who composed the Hindu epics.

The tendency “to see through everything” in the texts in catastrophism is a real one, for by seeing through everything, one is in real danger of seeing nothing at all to paraphrase C.S. Lewis once again. If there is no opacity to the texts, there is nothing to see. On Alford’s approach, one would have to understand even *comic books* such as *Superman* to nothing but “cleverly disguised propaganda” for the exploded planet cult. One might view coffee with cream and sugar as a “mixture,” as a “chimera”, and thus as a symbol of “meteorites” and exploded planets. One might view the current genetic chimeras of biologists and genetic engineers as a vast new program of symbols for the exploded planet, and so on and so forth. In the face of modern technologies that recapture the images recounted, Alford’s catastrophism reduces to ridiculousness, for his interpretive paradigm must explain them on the very same basis, as nothing more than manifestations of the exploded planet religion.

As interpretive approaches to paleophysics, then, no two schools could be farther apart than the catastrophist school and the “real war” school for a very obvious methodological reason. In the former, *one* particular modern physics model, the exploded planet hypothesis itself, is used to interpret *most if not all* textual themes as metaphors for that one thing. In the latter, however, *different* modern physics models, from “scalar physics” to the “exploded planet hypothesis” to “plasma cosmology” are used to *find correspondences between specific textual references and the modern model with a view to testing the accuracy of those texts and their various assertions*. Moreover, other areas of science are employed to make sense of other portions of the textual traditions, as, for example, in the use of genetic engineering to explain the occurrence of chimeras in those texts.

While both paleophysical approaches certainly challenge standard models of science and history, one may safely maintain that the catastrophist model exemplified in the works of Alford, the most popular and careful of the catastrophists, leads everywhere and nowhere all at once. It is difficult to conceive what sort of predictions it makes, other than to make predictions that more such metaphors can be found, and found almost *anywhere*. It ends by being nothing more than a well-footnoted compendium of the various types of metaphors for the one and only model it is willing to consider: the exploded planet hypothesis itself.

The “real war” model, in contradistinction from this, does not run quite so roughshod over the texts it considers, and moreover is able to make a prediction, namely, that artificial artifacts of the civilization that fought that war *might* be found and conclusively documented. And, as we shall discover in part two, there is yet another variable in the formula:

Mountains \approx planets \approx gods \approx “X”.

For now it is best to leave that “X” factor unstated. But once discovered and articulated, we shall see that it spells the death knell for Alford’s convenient reductionism.

In any case, such artifacts might be structures in the desert, to structures on other planetary bodies that evidence some type of machining or intelligent origin, to residual evidences within earthly DNA that indicate some prior manipulation, or the remains of some strange humanoid creature that is anomalous in some way, from its appearance to its size. To this last subject, giants, we now turn.

4.

TIAMAT'S GIANTS AND EARTH'S SKELETONS

“... there is also reason to think that some of those bones of giants, which did survive to be discovered, have been hidden from public view. That is to say, these proofs that giants exists have been collected.... The question then is why would museums choose to hide giants away behind closed doors and in locked cabinets to be seen only by a very select few? Could there be a conspiracy?”

Stephen Quayle. [146](#)

The previous chapters have suggested that the missing exploded planet may have been a large water-and-life bearing planet, of Saturn-sized mass. They have also suggested, if it was home to intelligent human-like life, that this exploded planet - “Tiamat” - may have required such life to have relatively larger physiognomies due to its higher gravity. In short, its “men” may have been giants. Such a “literal” confirmation of ancient myths with their numerous references to chimerical giants would likewise contraindicate the catastrophist interpretation of Alford.

The myths state that this giant race, or its precursor, “came down from heaven,” literally, and interacted with mankind, a thesis that, if true, would seem to predict a very odd kind of corroboration: there should exist both remains of such creatures, as well as testimony to their existence.

Fortunately there is a wealth of testimony, and some very suggestive evidence in the form of remains, concerning the existence, and strange features, of these giants.

A. Ancient Testimony to the Existence of Giants

1. *The Christian Church Fathers*

No less than that our exponent of divine predestination and the most important church father for the Latin Mediaeval Catholicism of the Western Church, Saint Augustine of Hippo Regius, wrote an entire treatise devoted to the subject of giants entitled “Concerning the Long life of Men before the Flood, and the Greater Size of Their Bodies.” The title is indicative of its contents, for it seems to reflect one strand of an ancient tradition within Christianity, going back to its Jewish roots, that mankind was once not only much longer-lived, but also of much larger physical stature. Augustine observes that

...some indeed do not believe that men’s bodies were formerly much greater than now.... But concerning the magnitude of their bodies, the graves laid bare by age or the force of rivers and various accidents especially convict the incredulous, where they have come to light, or where bones of the dead of incredible magnitude have fallen, as I have seen, and not I alone, on the shore by Utica, so huge a molar tooth of a man, that were it cut up into small models of teeth like ours, it would seem enough to make a hundred of them. But this I should think had belonged to some giant; for beside that the bodies of all men were much larger than ours, the giants again far exceeded the rest.¹⁴⁷

Note that Augustine is maintaining two things: (1) that graves of such giants had been uncovered through various accidents of nature, a point to which we shall repeatedly return, and (2) that he has seen the tooth of one such giant.

Stephen Quayle, a researcher into the subject of giants, observes that Augustine believed that mankind was “once both enormously larger and longer-lived than he is now, and that his stature has diminished in the course of ages to its present dimensions.”¹⁴⁸ He also notes that it is an Islamic tradition that Adam was as tall as a palm-tree.¹⁴⁹

But the situation is made even stranger by what the Church Fathers and other early Christian ecclesiastical writers themselves maintained, for far from dismissing the pagan myths outright as fanciful tales, they in fact appeared willing to seek some underlying prosaic explanation for their actual occurrence. As Celtic antiquities scholar Paul Pezron puts it:

All the ancient fathers, who in their writings have taken upon them to controvert the divinity of these imaginary gods, have spoken of them much after the same manner as Tertullian:¹⁵⁰ They made no scruple to own that Saturn and Jupiter were warlike and powerful men, that ruled over nations: and any one may read what Athenagoras, Theophilus of Antioch, Minutius Felix, Arnobius, Lactantius, Augustine, and others, say upon this account.¹⁵¹

This citation is intriguing for a different reason, for its source, Paul Pezron, a scholar of antiquities of the Celts, maintained that the legendary War of the Titans in Greek mythology had a basis in reality.

Pezron maintained that there was an original stock of giants, a “giant race” that migrated in two

tribal groupings, one into Europe, and the other into Asia Minor.¹⁵² The Asia Minor group, the Gomarians tribe of the Sacae, had followed its leader Acmon there, and established a city on the coast of the Black Sea called Themicyra, to honor his granddaughter Themis.

But the history takes a strange turn when these gigantic settlers in northern Anatolia began to call themselves “Titans.” So, to quote giant investigator Stephen Quayle, “here’s the interesting twist (and one that most modern historians miss). The Gomarian giants actually can be traced into Greek mythology and, as such, were actual individuals who were giants and who were treated as gods. Thus, far from being simply myths, it is possible to trace some of the Greek gods to actual historical figures.”¹⁵³

But how is this possible?

Because Acmon’s son, *Uranus*, who succeeded him in ruling their new conquests, was himself worshipped by his subjects as “a Man of Heaven.”¹⁵⁴ As Pezron goes on to note, the ancient author Simias of Rhodes gave Uranus the name “Acmonides,” or “son of Acmon,” an opinion that Hesychius shared.¹⁵⁵ In other words, “from this single family of giant Gomarian princes came ‘those who have passed for the greatest and ancientest (sic) gods of the heathen world.’”¹⁵⁶ So it would appear that the opinions of some Church fathers and other early ecclesiastical writers is not without its classical antecedents.

2. *Classical Sources*

But there is more to this story, for “while the minute (and often erroneous) stories of Nero and his fiddle and Julius Caesar and Brutus continue to be told, something as amazing as the fact that Roman legions on occasion battled giant soldiers has been covered up.”¹⁵⁷ Indeed, no less than the famous Roman historian and man of letters Pliny the Elder reported that the bones of one such giant, who had been observed by the Romans while he was alive, had been “brought by Marcus Scaurus from Joppa in Judea... The monster was over 40 feet long, and the height of its ribs was greater than that of Indian elephants, while its spine was 1 ½ feet thick.”¹⁵⁸

In fact, ever since Rome cast its imperial eyes in the form of Julius Caesar on the conquest of Gaul the disciplined Roman legions seem to have been dogged by encounters with the Northern branch of the Gomarians, that branch that migrated into Europe. Here, the legions ran into the stock of a new and formidable enemy: the Celts, and their cousins, the Teutons, or Germans.

This new enemy was something different than Rome had ever faced, and Rome had faced quite a bit, from Hannibal’s Carthaginian armies with its war elephants, to all manner of intrigue and scheming.

Not a lot is known about the people who would become known as the Celts. It is known that they migrated across Asia Minor, through northern Europe and into what have become the Celtic countries of Wales, Scotland and Ireland. Most accounts of them include references to the giants that were often found among them. The ancient Greek historian, Pausanias, called them “the world’s tallest people.” Modern historians now believe that, in fact, the giants among the Celts were a ruling class that held control over the indigenous population that formed the majority of Celtic tribes.

(The) modern historian, Gerhard Herm, agrees that the Celts were “blond giants” who struck terror in the hearts of every foe, even in the mightiest of mighty Rome. As such, the Celts fought several ferocious wars with Rome and captured, sacked, and burnt many Roman outposts to the ground. Although the Romans would eventually devise methods of defeating these giant warriors, attacking long legs that couldn’t be guarded by the massive shields these creatures carried, the blue-eyed, blond giants inspired terror among those facing them in battle for the first time.¹⁵⁹

The unusual size reported for the Celts was not a feature noted merely by Roman historians in the wake of the conquest of Gaul. The Greek historians Arrian and Diodorus also comment on their unusually large size, Arrian mentioning them in connection with Alexander the Great’s encounter with them after he had burned down one of their cities on the Danube in 335 BC.¹⁶⁰ Moreover, when Alexander queried the Celts as to what their worst fear was, they gave him the strangely intriguing answer that their worst fear was “that the sky might fall on their heads.”¹⁶¹ The Celts, it seems, preserved in their beliefs and legends, along with other ancient peoples, that there had been a time long ago when the sky had done just that.

But beyond Gaul, east of the Rhine, the Roman legions faced an even fiercer foe, indeed, the only foe ever to best the vaunted legions of Rome, the foe that closed out forever any Roman conquests in central Europe — in what today would be modern Germany — and that foe was the Teutons, or the Cimbri...the Germans. The classical historian Strabo notes of these tribes that they were ever “wilder, taller, and having yellower hair.”¹⁶² Indeed, when Caesar’s men at Besancon asked some Gauls, “who were themselves of great stature” about the Germans, Caesar wrote the following about the Gauls’ reply:

They described the Germans mentioning their enormous physique, their unbelievable valor, and extraordinary military training. The Gauls said that often when they had encountered the Germans they had not been able to endure even the expression on their faces or the glare of their eyes.¹⁶³

Indeed, at the famous Battle of the Teutobergerwald, the Germans would so utterly decimate four Roman armies in the brutal fighting that Rome would maintain a more or less defensive posture with respect to the Germans until the Western Empire’s final collapse. The Gallic-Celtic giants were one thing, but their even taller cousins across the Rhine were quite another.

Eventually, however, some of these Germans were captured by the Romans, and one of them, a particularly troublesome King by the name of Teutobokh, was paraded in Rome in the customary triumph. The Roman historian Floras reports that this king was so tall that when his captor returned to Rome, “Teutobokh could be ‘seen above all the trophies or spoils of the enemies, which were carried upon the tops of spears.’ This suggests that Teutobokh was easily nine feet tall and perhaps considerably taller.”¹⁶⁴

3. *Giant Remains and Other Testimonies*

The story of giants becomes even more intriguing once Europeans established (or perhaps, *re*-established) contact with the Americas during the great age of exploration, for many of the early explorers, from Vespucci, Sir Francis Drake, De Soto, to the great Coronado, report their encounters with giants. Pedro de Castaeda, for example, a member of Coronado's expedition, stated that some of the Cocopa Indians were giants "who could carry logs that six of the Spaniards couldn't budge."¹⁶⁵ Even more fantastically, one of Magellan's crew reported that when Magellan's fleet had anchored at Port San Julian "they were greeted by... a native giant" who was so tall "that our heads scarcely came up to his waist, and his voice was like that of a bull."¹⁶⁶ The place seemed a veritable haven of giants and remains of giants:

When Sir Francis Drake anchored at the same place in 1578, he didn't see as big a giant, but did report that men well over seven feet in height were there. When Anthony Knyvet visited in 1592, he wrote of men ten to twelve feet in height. Several skeletons ten to eleven feet long were discovered there in 1615 by crewmen from the Dutch schooner *Wilhelm Schouten*.

When Commodore Byron visited in 1764, he also found giants there. He later wrote in his log that there were men there "of a gigantic stature." One of his officers wrote of their height "... some of them are certainly nine feet, if they do not exceed it." This proved to be the last sighting of giants in the region.¹⁶⁷

Such multiple sightings from so many different witnesses, whose political agendas were, moreover, often in conflict with each other, makes collusion unlikely, and make it more likely that there really were giants in South America as recently as 300 years ago.¹⁶⁸

As indicated by the quotation from Saint Augustine that began this chapter however, it is the remains of the giants that perhaps tell the most interesting part of the story, for there is more to it than merely people of large stature.

a. Double Dentition

Giant researcher Stephen Quayle has assembled a veritable catalogue of testimonies and legends. Among a lengthy list of reports of giant remains of varying heights, Quayle notes that many of these remains bear a very unusual feature:

- In 1833, soldiers digging at Lompock Rancho, California, discovered a male skeleton 12 feet tall. The skeleton was surrounded by carved shells, stone axes, other artifacts. The skeleton had double rows of upper and lower teeth. Unfortunately, this body was secretly buried because the local Indians became upset about the remains.¹⁶⁹
- A giant found off the California Coast on Santa Rosa Island in the 1800's was distinguished by its

double rows of teeth.¹⁷⁰

- In Ohio in 1872, an earthen mound was discovered to contain three skeletons that in life would have stood at least eight feet tall. Each also had double teeth in front as well as in back of their mouth and in both upper and lower jaws.¹⁷¹
- Near Toledo, Ohio, 20 skeletons were discovered with jaws and teeth “twice as large as those of present day people.” The account also noted that odd hieroglyphics were found with the bodies.¹⁷²
- Miners in Lovelock Cave, California, discovered a very tall, red-haired mummy in 1911. This mummy eventually went to a fraternal lodge where it is used for “initiation purposes.”¹⁷³
- The Catalina Islands, off California, are the home of dwarf mammoth bones that were once roasted in ancient fire pits. These ...were eaten by human-like creatures who were giants with double rows of teeth.¹⁷⁴

What interests us here is the fact that not all reports of giant remains (and I have listed but a very few of Quayle’s extensive catalogue) include the mention of double rows of teeth, but clearly, there are enough mentions to suggest that at least some of these creatures were carriers of a very unique gene, if not of a very different genetic make-up altogether.

But what was the *purpose* of such double dentition? No one knows for sure, but there is an interesting suggestion in the literature - both ancient and modern — concerning giants. The Old Testament book of Numbers records that not only was Canaan, the “promised land,” a land full of giants, but that these giants inhabited a land “which eateth up the inhabitants thereof,” implying cannibalism was a favorite practice of giant races.¹⁷⁵ Even the children’s fairy tale of Jack and the Beanstalk records that the giant of the story is a man-eater.

b. Sexedigitism

There is yet another unusual feature reported for some giants. The Old Testament book of II Samuel (III Kings in the Catholic and Orthodox versions), 21:19-22 records that one such Canaanite giant “had on every hand six fingers, and on every foot six toes.” This is repeated in I Chronicles 20:6. Even more peculiar is the fact that ancient Mayan images of their kings often depict them as having six fingers and six toes.¹⁷⁶

B. Strange Legends and Chronological Clues

The picture becomes even more unusual when one considers various legends from around the world, legends that associate creation with wars, catastrophes, and with giants. The Inca legend of its creator god Viracocha, for example, not only has him annihilating previous pre-human worlds, the first by fire and the second by flood, he then takes two of his servants, who are “sometimes portrayed as a sort of Adam and Eve” and then

Went to (lake) Tiahuanaco where he sculpted a great piece of stone, forming an image of all the nations he intended to create. When he was finished, he commanded his two servants (to) memorize the names of all the tribes he had depicted. Viracocha then sent the two servants down different roads to tell the various tribes to “go forth and multiply and settle the land.” Viracocha then took another road, doing the same thing. As the god and servants went down the roads calling, people emerged from the springs, valleys, trees and other places and then spread through the countryside and formed the nations of Peru.¹⁷⁷

Author Stephen Quayle rightly notes that this creation account appears to record the destruction by fire of one civilization that occurred before the Genesis account, a civilization that obviously would be “pre-Adamic”, and then recorded the destruction of another civilization by the Flood. There is even another odd parallel, and this is the creation of various tribes by Viracocha and his servants “calling out” to them, like the Genesis 1 account of God fashioning the world by a series of spoken fiat.¹⁷⁸

However, this is not the most unusual thing about Viracocha. For the Incas, Viracocha was also often described as a giant, with very light skin!¹⁷⁹

In any case, the references to a creation and destruction prior to the creation of the current heaven, earth, and mankind is a clue, as we shall see, of when the scenario of an ancient war and planetary destruction took place: somewhere between the creation of all and the creation of man.

A stranger creation-flood-destruction account occurs in the legends of the North American Okanagan Indians.

(In) 1886, historian Hubert Howe Bancroft wrote of the Okanagan myth of their lost island of origin, *Samah-tumi-whoo-lah*:

“Long, long ago, when the sun was young and no bigger than a star, there was an island far off in the middle of the ocean. It was called *Samah-tumi-whoo-lah*, meaning “hite Man’s Island.” On it lived a race of giants — white giants. Their ruler was a tall white woman called Scomalt.... She could create whatever she wished.

For many years the white giants lived at peace, but at last they quarreled amongst themselves. Quarreling grew into war. The noise of battle was heard, and many people were killed. Scomalt was made very, very angry....

(S)he drove the wicked giants to one end of the White Man’s Island. When they were gathered

together in one place, she broke off the piece of land and pushed it into the sea. For many days the floating island drifted on the water, tossed by waves and wind. All the people on it died except one man and one woman...

Seeing that their island was about to sink they built a canoe... after paddling for many days and nights, they came to some islands. They steered their way through them and at last reached the mainland.¹⁸⁰

The parallels here with the Babylonian *Enuma Elish* and the destruction of Tiamat are amazing.

If one understands “island” to mean “planet”, following the suggestion of Alan Alford, and the “sea” as being surrounding space as he also suggests, then Scomalt’s destruction of “White Man’s Island” records the destruction of a planet. Moreover, the parallel is even more exact in that the apparent “ruler” of both planets is a woman, who becomes angry and causes great destruction. Here is where Alford’s “metaphor of exploded planet catastrophism” once again breaks down, for the Okanagan legend clearly has it that the “island” or planet is *inhabited* by intelligent life, a race of “white giants,” exactly as one would expect if the exploded planet were a large, solid, life-bearing planet, as has been previously conjectured! In other words, the Okanagan Legend *records a real war as the cause of the destruction of a planet, a planet that is life-bearing.*

But there is more.

The Legend also makes it clear that the survivors negotiated their way through “some islands,” braving “waves and wind” after having constructed a “canoe,” until at last they came to the “mainland.” If one extends the “islands” equals “planets” metaphor, more details of the story emerge, for it is clear that the “mainland” differs from the “islands” the survivors negotiate through in *size*. In other words, these “islands” might very well be the asteroid belt itself, the debris field of a previously exploded planet — shades of Van Flandern’s revised “multiple exploded planet hypothesis”! Moreover, even the “waves” and “wind” now take on a new significance, perhaps explaining why only two of the “white giants” survived, for the waves and wind might very well be the sheets of a violent plasma “electric wind” that permeated the “sea” of local space after the catastrophe.

In short, viewed in this way, the Okanagan Legend is about a war that exploded a planet, on which dwelt an intelligent race of giants, ruled by a woman, which race then constructed an “ark” of sorts to undertake a perilous journey to a new planet home. The detailed parallels to the Exploded Planet hypothesis and its massive water bearing planet, and to the Babylonian war-creation epic, the *Enuma Elish*, are amazing, and in my opinion, not coincidental.

C. Curious Coincidences and Connections

But if these parallels are not coincidental, what might they imply? Obviously, one answer would be that both the *Enuma Elish* and the Okanagan Legend, stem from some common source far in the mists of “prehistory,” a common “paleoancient Very High Civilization.” If so, then there ought to be similar connections between the classical Old World and the pre-Columbian New World.

This is indeed the case, but it presents even more difficulties. For example, there are clear cases of Egyptian remains in North America. As has been seen, in some few cases, the remains of giants found in the Americas are also found surrounded by hieroglyphs having similar characteristics to those of Egypt. Former Harvard University professor Barry Fell even believes that the Micmac Indians of Maine and Eastern Canada employed a script of hieroglyphs actually derived from Egyptian and Libyan symbols. He believes this because of the highly anomalous discovery of a tablet on shell mound on Eagle Neck on Long Island, New York. The tablet “is now stored at the Museum of the Americas in New York.”¹⁸¹

A deeper connection is to be found in human mitochondrial DNA itself. The conventional theory of the origin of the North and South American native Indian populations is, of course, that they migrated long ago over the “land bridge” across the Bering Straits between Asia and North America. In 1994 a team of Emory University scientists surveyed American Indian groups and their mitochondrial DNA, and found “four major varieties, each of which had components associated with groups in Asia.” Had the study stopped there it would have been a resounding scientific confirmation of the standard version of “prehistory.” But unfortunately for that version, the study also found a fifth group of mitochondrial DNA among the Ojibway, the Sioux, Navajo and other tribes, and “the only other place this group shows up is among Europeans.”¹⁸²

The connections become even more amazing, if not perplexing. Consider the fact that the capital of the Aztecs, the magnificent “Venice of the New World,” Tenochtitlan, was situated “on an island in a large lake surrounded by canals.” But why build such a city in such a difficult place, one that required extraordinary engineering skills and labor? The answer: The city “was apparently built as a ‘replica’ of the one” that, in Aztec myths of their origins, “lay to the East of them and from which their ancestors came.” What makes this intriguing is “that no such city has ever been found — *except in the description Plato gave of Atlantis.*”¹⁸³

While it would be foolhardy to suggest that the Aztecs had read Plato, the “coincidence” points to another “deep connection,” since Plato claims to have derived his famous allegory of the lost planet from Egyptian sources, and the parallels of Egyptian legends with some of those in the New World’s indigenous populations has perplexed many scholars of the subject, from alternative researchers to those securely ensconced in the towers of academic orthodoxy.

But there is one *other* possibility to be considered, one that, to my knowledge, has not ever been mentioned in connection with the Aztec legends of their origins “in the east.” The Aztecs, like the Mayans, were gifted astronomers and mathematicians. Consequently, *what if the reference to “eastern origins” is an astronomical one?* As I noted in *The Giza Death Star Destroyed*, if one follows Alan Alford’s prescient suggestion that “eastern” references refer to planets lying *outside* the

Earth's orbit of the Sun — Mars, Jupiter, Saturn — and “western” references to mean those bodies *inside* the Earth's orbit — Venus, Mercury, and the Sun itself — then the Aztec legends of their origins in the east, in this one instance at least, might be preserving yet another residue shared in common with the classical Old World of antiquity. It might be telling us that the Aztec's original ringed city of canals and islands in the middle of a lake, was on another planet, if it was not the planet itself.

D. Conclusions

So what has emerged from this brief excursion into “giantology”? First, both ancient and more modern testimony exists testifying to living giants and to their remains. If this is loose corroboration of the scenario of a large exploded planet that was water and life-bearing, then perhaps such creatures or their remains as are found on earth are not indigenous to this planet. Their larger physiologies would appear to be more appropriate to a planetary environment of larger mass and greater gravity. Over time, as these creatures grew accustomed to the earth’s gravity, micro-evolutionary processes may have led to an adaptation of their physiology to smaller sizes.

Secondly, if this were the only corroborating evidence of the scenario, then it would, as has been noted, be rather loose and unconvincing. But the existence of a class of legends among many cultures — and I have cited but a very few — that refer to a giant race among ancient peoples increases its evidentiary value.

Thirdly, the fact that some of these legends, like the Okanagan Indian legend of Smocalt’s destruction of a planetary “island” with its warring “giants” or Viracocha’s two previous destructions of the world by fire and flood — if viewed from the paleophysical perspective suggested by Alford where “islands” equal “planets” and “waters” or “seas” or “oceans” represent the surrounding local space - seem to corroborate the scenario of an ancient and very *real war* as the cause of the destruction of that planet. The detailed parallels between the Okanagan Legend and the Babylonian War-Creation epic, the *Enuma Elish*, make such a scenario more likely.

Fourthly, the fact that the Okanagan Legend *explicitly* refers to a race of giants as inhabitants of that exploded, lost world and their subsequent survival and transplantation to another “island” planetary home, plus the existence of remains of such giants and reliable classical and modern testimony as to their existence would seem to be a piece of evidence that would suggest, contra Alford, that these legends are *not* metaphors of an “Exploded Planet Cult” or any other form of naturalistic catastrophism, but the very real, if garbled, accounts of a real war and its aftermath. The parallel with Mesopotamian accounts is further strengthened by the fact that some *other* North American indigenous Indian legends feature “monsters and giants which both *perish by the thunderbolts sent by the Great Spirit.*”¹⁸⁴ This parallels the *Enuma Elish* and Marduk’s divine arrows and thunderbolts. Contrary to Alford, the giant remains are obviously *not* mere metaphors; their existence would thus seem to constitute loose corroboration of the fact that the wars in which these giants were repeatedly engaged were not mere metaphors either.

It is now time, then, to consider what type of weapon would be involved that would allow inhabitants on earth both to see and to record plasma discharges accurately.



A “Fossilized Irish Giant” Some 12 feet 2 inches tall, leaning against a Railroad Car at Broad Street Goods station, London, in the 19th Century (Stephen Quayle’s Genesis 6 Giants)

French Chart Showing Comparisons of Giants Based on Physical Remains (or in the case of Goliath, biblical testimony). Quayle records that “Near Mezanno in Sicily in 1516 there was found the skeleton of a giant whose height was at least 30 feet... and in 1548 and 1550 there were others found of the height of 30 feet. The Athenians found near their city skeletons measuring 34 and 36 feet in height. In Bohemia it is recorded that there was found a human skeleton 26 feet tall, and the leg-bones are still kept in a medieval castle in that country. ”

Chart of Known, Excavated Giant Skeletons

Géant de Trapani

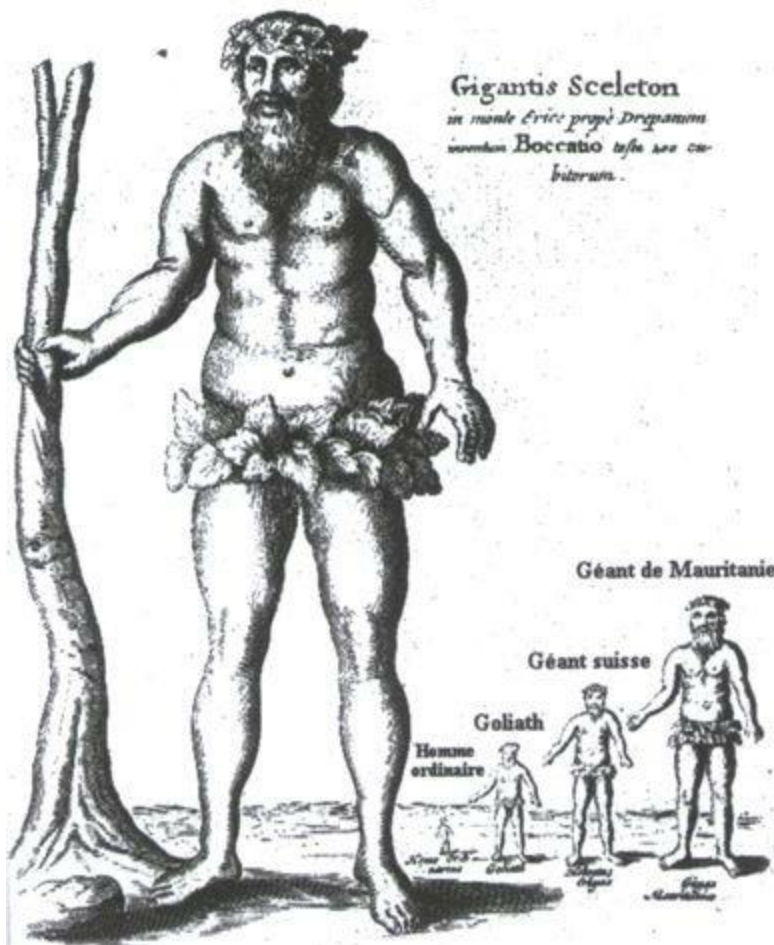

PROMETHEUS PULSES THE PULSARS AND GRINDS HAMLET'S MILL: THE DISTURBING STELLAR AND GALACTIC POSSIBILITIES

“That Tiamat is the Milky Way, and no ‘Great Mother’ in the Freudian sense, and more than Ganga, Anahita and others, seems by now obvious. ”

*Giorgio de Santillana and Hertha von Dechind*¹⁸⁵

“If extraterrestrial civilizations are attempting to communicate with us and are distinguishing their transmissions by doing ‘something that can’t be done in nature,’ then pulsar signals certainly are the closest thing known to fit this criterion. ”

*Dr. Paul LaViolette*¹⁸⁶

*“The reader now has a clear concept for the great interest in ancient archeology exhibited by modern military experts. It is highly likely that the civilizations that existed prior to the great cataclysm were far in advance of our own with respect to use of these powerful energy devices. ”*¹⁸⁷

James M. McCanney

A. Hamlet's Mill: Another Mythological Background

1. The Galactic Context of Ancient Myths

One of the most famous and respected scholarly attempts within the mainstream of academia to construe ancient myths from a wide variety of cultures — Celtic, Scandinavian, German, Graeco-Roman, Sumerian, Egyptian, Persian, Native American, and Hindu-Vedic — in a paleophysical sense is the monumental and critically important work by philosophers Giorgio de Santillana and Hertha von Dechind, *Hamlet's Mill: A Essay on Myth and the Frame of Time*. While it would be impossible to summarize their work adequately here, one salient conclusion about their study should be noted. This is that many of the images and motifs from a supposedly “primitive” time were subsequently wildly misinterpreted because the galactic astronomical context to which those motifs referred was ignored, if it was not totally unknown. While any attempt to summarize their work here would inevitably fail, some concepts should be highlighted, since they dovetail I have said elsewhere¹⁸⁸ concerning ancient concepts of space and the harmonic interconnectedness of things in it.

Indeed, De Santillana and Von Dechind noted that one very curious feature of this “archaic cosmology” was not only its emphasis on a primeval “cosmic harmony,” but also its description of the creation of the *present* world as a kind of “breaking asunder” of that harmony, “a kind of cosmogonic ‘original sin’ whereby the circle of the ecliptic (with the zodiac) was tilted up at an angle with respect to the equator, and the cycles of change came into being.”¹⁸⁹ And they hint at the tremendous anomaly at the heart of this cosmology with an astute observation, an observation many other researchers have pointed out, for such a view requires an astronomical knowledge and “prodigious feats of concentration and computing.”¹⁹⁰ This implies that underlying the relatively “primitive” states of ancient cultures, even ancient cultures as sophisticated as Babylon or China, was something even more sophisticated. Here De Santillana and Von Dechind halt, never speculating on what that might be. They are simply concerned with a cataloguing of the cross-cultural motifs, and with an elucidation of their possible meaning in physical and astronomical terms.

One common implication of their cross-cultural comparative mythology approach is that the ancient cosmology was profoundly aware that “the fabric of the cosmos is not only determined, but overdetermined *and in a way that does not permit the simple location of any of its agents*, whether simple magic or astrology, forces, gods, numbers, planetary powers, Platonic Forms, Aristotelian Essences or Stoic Substances. Physical reality here cannot be analytical in the Cartesian sense; it cannot be reduced to concreteness even if misplaced. *Being is change, motion and rhythm, the irresistible circle of time*, the incidence of the ‘right moment,’ as determined by the skies.”¹⁹¹ In other words, “there is no simple location, no analytical space.”¹⁹² While they observe that these ideas “were incompatible with anything that our physics can think of,”¹⁹³ this is not entirely true. While the “on-locality” of any of the active agents in the ancient cosmology was something of a puzzle to De Santillana and Von Dechind, in fact, with the advent of Quantum Mechanics and Bell’s Non-Locality Theorem, it is not a puzzle at all, but quite the reverse.

2. *The Astronomical-Galactic Meaning of "Earth", "The Flat Earth", and the "our Corners of the Earth"*

Indeed, within ancient myths it would seem that terms such as "Earth" are operative on a number of discrete but related levels. For example, while "Earth" may indeed refer at the most prosaic level to the planet we are standing on, it also has *a meaning in relation to the total system of the galaxy*:

In the most general sense, the "earth" was the ideal plane laid through the ecliptic. The "dry earth," in a more specific sense, was the ideal plane going through the celestial equator. The equator thus divided two halves of the zodiac which ran on the ecliptic, $23\frac{1}{2}^{\circ}$ inclined to the equator, one half being "ry land" (the northern band of the zodiac, reaching from the vernal to the autumnal equinox), the other representing the "waters below" the equinoctial plane (the southern arc of the zodiac, reaching from the autumnal equinox, via the winter solstice, to the vernal equinox. The terms "ernal equinox," "Winter solstice," etc are used intentionally because myth deals with time, periods of time which correspond to angular measures, and not with tracts in space.¹⁹⁴

This way of viewing the "earth" is a component in a total system is part of that "open systems paradigm" we first encountered in *The Giza Death Star*¹⁹⁵ and is a very modern view, so modern, in fact, that it lies on the cusp of some of the most advanced ideas in systems theory.

Thus, the "flat earth" is not a reference to some presumed primitive view of the ancients who looked at our own planet like a dinner plate or a pancake, but to the celestial, galactic equator:

The mythical earth *is*, in fact, a place, but this place is not our "earth" at all, neither our globe, nor a presupposed homocentric earth. "Earth" is the implied plane *through the four points of the year, marked by the equinoxes and solstices, in other words the ecliptic. And this is why the earth is very frequently said to be quadrangular. The four "corners,"* that is, the zodiacal constellations rising helically at both the equinoxes and solstices... are the "points" which determine an "earth." Every world-age has its own "earth." It is for this very reason that "ends of the world" are said to take place. A new "earth" rises, when another set of zodiacal constellations brought in by the Precession determines the year points.¹⁹⁶

There is yet another way to understand the "four corners" of the earth, and that is as the vertices of a spherically circumscribed and embedded tetrahedron. Note then that the "four corners of the earth" has essentially two simultaneously functioning meanings: (1) as a reference to the Platonic solid of an embedded tetrahedron in a sphere, the "four corners" being its four vertices, and (2) as an astrological-astronomical reference to the constellations rising at the solstices and equinoxes. It is as if the ancient myths were trying to tell us that these two meanings might be related in a fundamental physical way that we do not understand. Perhaps, however, the clue might lie in the other strange characteristic of ancient mythological cosmology that De Santillana and Von Dechend have already pointed out: the ancients' view of the active agents of their universe — in this case, the globe of the

earth, and then the wider “galactic earth” — as being *non-local* in nature.

Another possible clue into an underlying sophisticated — and lost — paleophysics behind this non-local view of active agents is afforded by Plato and Aristotle. For the former, in addition to the “four elements” that make up every physical object in the world, there is a “fifth” element which, aptly enough, Plato called the “aether” which “contains the four earthly elements but is wholly removed from them.”¹⁹⁷ Similarly, Aristotle changed this to a kind of “crystalline heavenly ‘matter.’”¹⁹⁸ The view is not unique to the Greeks. The Egyptians certainly had their version of this strange transmutative *materia prima*, as did the Mesopotamians, the Hindus, the Chinese... almost every culture on earth had some version of it. For our purposes, it might provide a basis for the non-local character of the active agents of ancient cosmology. We shall eventually return to this point, but for the moment, we must note one more strange “galactic context” of an ancient motif.

3. *The Galactic Meaning of “Tiamat”*

In this case, the motif is that of “Tiamat,” the Babylonian goddess who revolted, led a cosmic war with other gods, and was eventually defeated by the god Marduk.¹⁹⁹ As I noted in *The Giza Death Star Destroyed*, “Tiamat” was not only the name for a “goddess,” but the name for an exploded planet in our own solar system, a water bearing planet.²⁰⁰ Indeed, her name can mean “salt waters” and can imply the “primeval waters,” making her yet another symbol that can operate on a multitude of levels. As I also noted in *The Giza Death Star Destroyed*, her name may actually be a *title* conferred on specific individuals or rulers of that now missing planet. She can refer to the earth’s oceans, as well as another water bearing planet. And finally, as “primeval waters” she can also refer to the “deep” or to the transmutative aether or medium itself. In this last context De Santillana and Von Dechind observe that she can also refer obliquely to the Milky Way galaxy.²⁰¹

4. *The Celestial, or Galactic War and Deluge, and Mars-Nergal: The “Great Leaping One”*

One of the overlooked areas of De Santillana’s and Von Dechind’s work is the galactic and astronomical-astrological context in which they understand the ancient mythological references to the Deluge, to war, and other apocalyptic imagery. An entry into their discussion is afforded by their remarks on the gigantic war between the Pandavas and the Kauravas in the Hindu epic, the *Mahabharata*: “The epic states unmistakably that this tremendous war was fought during *the interval between the Dvapara and the Kali Yuga.*”²⁰² A significant clue is thus afforded from yet another mythological source as to when it dates its major “war of the gods in heaven.”

To see why, a brief summary of Hindu thought on its “world ages” or “yugas” is in order. In its most basic form, there are four great “yugas” or ages. They begin in a “Golden Age” and each yuga thereafter is an age that is declined from the previous one. Each age is thousands of normal years in length, though each age is of a different length. In order then, these yugas, with their lengths in years, are:

The Satya Yuga:	1,728,000 years
The Treta Yuga	1,296,000 years
The Dvapara Yuga	864,000 years
The Kali Yuga	432,000 years

The final yuga, named after the notoriously bloodthirsty deity Kali, is an age of darkness, chaos, evil deeds, and war. Observe also that each yuga is exactly half the length of the yuga previous to it, until the cycle returns.

Note also that in Hindu teaching, the world currently is in a Kali yuga, which began — depending on the authority one consults — approximately 3000 BC. But if the *Mahabharata* refers to events of the *previous* transition from the Dvapara to the Kali yugas, running through the full cycle, then one is looking at a war that occurred between 3,898,000 and 4,320,000 years ago. While many would object to taking the epic this literally here, it is nonetheless highly intriguing that the great war recounted at such length and fought with such eerily modern-sounding and awesomely destructive weapons in the *Mahabharata* occurs in very roughly the same time frame as Van Flandern’s *second* exploded planet event, which occurred ca. 3,200,000 years ago. In other words, we are once again looking at the possibility of a real war, involving real planets blown up in a deliberate act of that conflict.

Let us now turn our attention to a seemingly unlikely source for additional perspective of this ancient war and the “cosmological original sin,” and the astronomical meaning it entails: the myths of the ancient Germanic peoples of Scandinavia. De Santillana and Von Dechind observe that, like the Hindus, and indeed, like the Babylonians and the Greeks, the ancient Teutons also had a Golden Age, who’s passing was marked by a war between the ruling “good” god and his ministers and a new race of giants who sought to overturn the old harmonious order.

Not having “multiplied” yet, this first generation of the world established the Golden Age under the rule of Him of many names — Enki,²⁰³ Yima,²⁰⁴ Freyr²⁰⁵ and many more. “But these sons

whom he begot himself, great Heaven (*megas Ouranos*) used to call Titans (Strainers) in reproach, for he said that they strained and did presumptuously a fearful deed, and that vengeance for it would come afterwards,” as Hesiod has it (*Theogony* 207-10).²⁰⁶

But what was it that these Titans - or giants or *Nephilim* or Annunaki or whatever one wishes to call them - had done? De Santillana's and Von Dechind's understanding of the galactic context of ancient myths shows exactly what was involved:

...It was bound to happen ...when future generations would construct “forbidden ways to the sky,” or build a tower which happened to be too high. The one secure measure, the “golden rope” of the solar year, is stretched beyond repair. The equinoctial sun had been gradually pushed out of its Golden Age “sign,” it had started on the way to new conditions, new configurations. *This is the frightful event, the unexpiable crime that was ascribed to the Children of Heaven. They had nudged the sun out of place, and now it was on the move, the universe was out of kilter and nothing, nothing — days, months or years, the rising or setting of stars — was going to fall into its rightful place any more... and now the time machine had been set rolling forever, bringing forth at every new age “a new heaven and a new earth,” in the words of Scripture. As Hesiod says, the world had entered now the second age, that of the giants, who were to wage a decisive battle with the restraining forces before their downfall.*²⁰⁷

While De Santillana and Von Dechind would agree with Alford that the “war” motif is purely metaphorical, they would not have, as Alford does, reduce this imagery to a flat univocal and monotonous reference to an exploded planet and falling meteorites. In fact, to do so would miss the point entirely, for what the ancient myths are trying to say is not only that a planet exploded, but that the war was truly cosmic in nature, and affected all the celestial bodies of local space, including “earth.” In the Norse version, interestingly enough, this “end of the world” is brought about by sounding the apocalyptic trumpet, the Gjallarhorn, which has a “sound which reaches all the worlds.”²⁰⁸ Universal sound, capable of wreaking havoc throughout the “universe”, i.e., all the worlds in the galaxy.

Indeed, as De Santillana and Von Dechind observe, the Graeco-Roman cultural complex is full of references to a celestial catastrophe of such magnitude that even the “immoveable joints of the universe” were shaken and the “very axle” running “through the middle of the revolving heavens” was “bent.”²⁰⁹ At the minimum, this last reference is nothing less than a statement that the angle of the earth's axis of rotation relative to the ecliptic was altered in some drastic fashion.

But what if the reference to a war is taken literally and not metaphorically? Only if one takes it *this* way do some interesting things now emerge. At this point, we shall now begin a process of periodically summarizing the emerging case, adding, as we go, new details. For now, the details we have assembled are these:

1. Van Flandern's Revised Exploded Planet Hypothesis indicated two events, one at 65,000,000 years ago, roughly coincident with the extinction of the dinosaurs, and another “lesser” event at 3,200,000 years ago, roughly coincident with the appearance of the first humans according to the

standard mainstream theory;

2. This second event roughly corresponds with the timing given for the Great War in the *Mahabharata*;
3. *Both* events must have altered the geometry of local space and the astronomical arrangement of the heavens;
4. One or both events were observed and recorded, making it likely the *second* event was recorded, and referred to as the result of a *war*;
5. A case can be made, based on the plasma cosmology of Hannes Alfvén and the petroglyphs observations of Anthony Peratt, that ancient humans observed large plasma discharges in the heavens, though these petroglyphs cannot be dated to the time frame of Van Flandern's second exploded planet event nor to the *Mahabharata's* Great War;
6. Further basis for believing that such discharges were *observed* is afforded by the peculiar resemblance of ancient depictions of the lightning bolts of the gods, such as Ninurta (with whom we shall much to do in part two), or ancient Greek depictions of the thunderbolts of Zeus, to the models of plasma instabilities observed by Peratt in the laboratory.²¹⁰ The fact that these resemblances are so exactly described in ancient art and drawing, and, as we shall see in part two, described in texts as being weapons of war, strengthen the case that we are both looking at observed events and events of a *real war*. If so, then it follows that the "broken and shattered geometry" of local stellar and galactic space described in ancient myths is a result, as they themselves attest, of a war. In other words, the motif of war in the myths is not a metaphor for recurrent catastrophism, but the real cause of catastrophes, just as the myths state.
7. One or both planets may have been large water-bearing planets, and if of higher gravity than earth, and if home to intelligent humanoid life, then they may have been home to a race of "giant" like creatures;
8. Thus the explosion of such a water bearing planet would give rise not only to the asteroid belt, but, as the shock wave from that event spread through local space, would inundate first Mars, and then the Earth, with debris and water. Thus, the tremendous hemispherical "gouging" by sudden flood waters often commented upon by Martian planetary geologists is explained. One should therefore expect to be able to find references of a *celestial* Deluge.²¹¹ Of course, there is no lack of references from various mythological traditions referring to waters in or above the heavens. Perhaps it is time to take them less metaphorically!
9. Furthermore, if the exploded planet *did* have life, *and if* this life was of a high degree of sophistication and technological ability, its civilization might have been interplanetary in nature. The nearest planets capable of sustaining such life would naturally have been Earth, and Mars. As such, one might be expected to find mythological associations of Mars with war, which is in fact the case. In fact, it is highly significant as we shall see that the Vedic tradition refers to Mars as "the Great Leaping One."
10. This war brought an end to an age and was fought between the "gods" and a race of giants, a theme common to mythological traditions from Sumer, Babylon, and Greece to Scandinavia and the Celts.

11. There does exist artifact and textual evidence of giant remains from all over the globe, which loosely corroborate the existence of anomalously large intelligent humanoid beings referred to in ancient texts.
12. Some traditions such as the Sumerian and the Biblical, ascribe the origin of this giant race to a mingling of the “gods” with “men.” The *Enuma Elish* makes it clear that Tiamat fought the war in part by creating chimerical creatures.

The image of the “divine lightning” or the thunderbolt of the gods will become quite crucial later on in this chapter.

B. Tossing Comets at the Sun: McCanney's Version

As was seen above, De Santillana and Von Dechind referred to the frightful deed of the “Childrer of Heaven” as having been to “nudge the sun out of place”, which they understood to be a metaphor of the alteration of the angle of the Earth’s rotation relative to the plane of the ecliptic. But might there be an additional interpretation, one of actually somehow “nudging” the Sun, of disturbing it in some fashion that would have dire consequences for the solar system?

The first to give a hint of this possibility is alternative researcher, and physicist James M. McCanney. He reproduces the following photograph which came from the SOHO satellite, a satellite which “monitors the sun on a daily basis.”²¹² To appreciate the significance of the photograph in McCanney’s view, it is necessary to understand a little about his theory of the electro-dynamic solar system, and comets.

For McCanney, as for the plasma physicists, the solar system is not electrically neutral. The Sun, of course, pours out a prodigious amount of electrical and nuclear energy every day. But in McCanney’s view as in the plasma cosmologists’s view, this means that on occasion and under certain conditions, the planets themselves can become electrically polarized, and thus, filamentary current can arc between various bodies when the charge is sufficient *or when one polarized body approaches near enough to another differently polarized body. And* this holds true for comets as for any other body. In short, comets are not electrically neutral, and their corona or “tail” is a sign of this effect.

Now let us consider the 1998 SOHO picture of the Sun.

McCanney's Comets “Shot Across the Bows” from the 1998 SOHO Satellite Picture

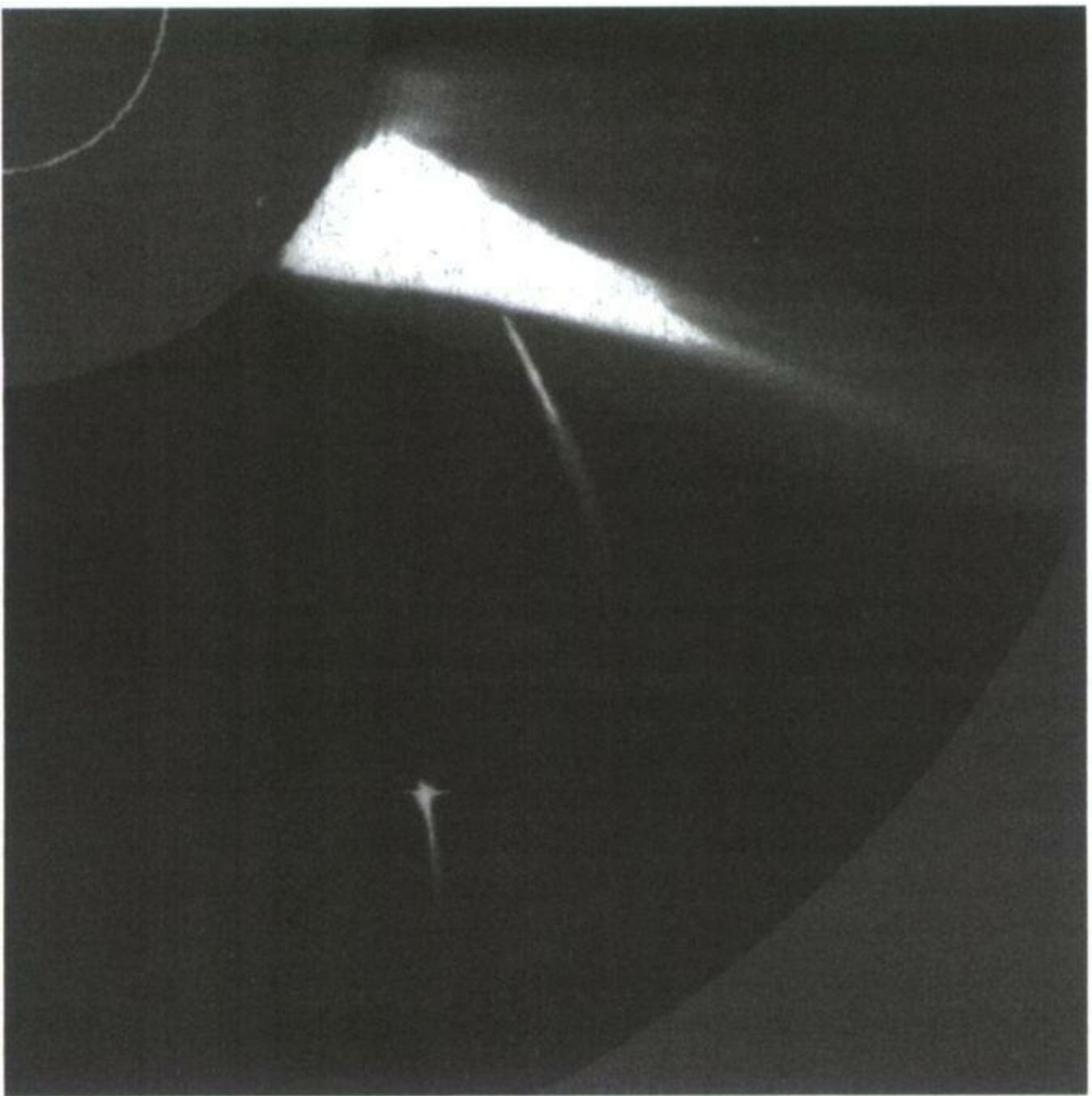

Note in the upper left hand corner one sees the Sun, and note the large solar flare. The two “comets” are clearly visible, with one very near the solar flare.

Now let us cite McCanney in full:

Unexpectedly the two streaking comets came directly into the solar vicinity and flew directly through the intense solar flare to the lower right of the sun. The first comet apparently missed by just a small amount whereas the second made a direct hit through the flare

The cover figure has far more meaning than that of just a few comets passing by the sun. Along with the immense solar which “the experts” said was mere coincidence, came a buzz out of the high levels of the national and international security agencies who monitor space for any intruders. The word from these sources was that this was a “shot over the bow” or also saying “look what we can do...look how accurately we can aim these puppies”. This is not me talking,

but as I said, this was the buzz out of the security agencies.[213](#)

McCanney is implying, in other words, that the comets were artificially and intelligently targeted at the sun, and moreover, that they were polarized in such a fashion as to *cause* the solar flare. In other words, the immense flare, a *plasma discharge*, was not electrically neutral, but of one electrical polarity, and the comet was of another. And this, of course, is implying that someone was doing the “shooting”, had the *technology* to do the shooting, and that it was not *us*. How else account for the fact that the “comets,” to use McCanney’s apt wording, “unexpectedly” came near the sun?

But all this is merely prologue....

C. Pulsing the Pulsars: Physicist Paul LaViolette's Promethean Star- and Galaxy-Sized Weapons

Physicist Paul LaViolette figured prominently in my *Giza Death Star* trilogy, and rightly so, for he truly is a modern day Prometheus who, as we shall see, is not afraid, in spite of his academic credentials, to think in bold terms, and to outline the physics of capturing the fire of the stars, and like De Santillana and Von Dechind, he thinks in terms of the galaxy itself as sources of energy and as means of communication. But as we shall also see, he goes much further than theorizing about *communicating* literally with, i.e., *by means of*, the stars, but using them for far deadlier purposes. And LaViolette is signally important for yet another reason as we shall see, for his work along with the scalar physics work of Lt Col. (US Army, Ret.) Tom Bearden provides the basis for solving one of the greatest mythological riddles of them all.

LaViolette, it should be noted, has a BA in physics from Johns Hopkins and a PhD from Portland State in system theory, and is a member of the American Astronomical Society. Notwithstanding these credentials from mainstream institutions, LaViolette is not afraid to think, and to think *deeply*, outside of the box.

But what exactly has LaViolette to do with the stellar and galactic context into which De Santillana and Von Dechind place their own paleophysics interpretation of mythological motifs? A great deal.

LaViolette begins his most recent book, *The Talk of the Galaxy*, with the history of the discovery of pulsars, a kind of star that emits pulses or bursts of radio signals *at regular intervals of time*. After the first pulsar was discovered in July of 1967 by Cambridge graduate student Jocelyn Bell and her professor Anthony Hewish,²¹⁴ its strange characteristics began almost immediately to perplex astronomers. After observing this first pulsar for a few months, its signal suddenly faded, and then reappeared again. Hewish “became convinced that they had detected a new kind of astronomical source.”²¹⁵ The regularity of the pulses led the team to designate the source “LGM 1, the acronym ‘LGM’ standing for ‘Little Green Men.’”²¹⁶ In December of 1967 Jocelyn Benn found a second pulsar, designated LGM 2.

Obviously, the regularity of the pulses had opened the two astronomers to the possibility that they were dealing with signals from some intelligence, but since the two pulsars were separated by 4000 light years, they concluded naturally enough that two civilizations were involved.²¹⁷ Over the next few months as more and more pulsars were discovered, MIT radio astronomer Alan Barrett was quoted in the *New York Post* as being open to the possibility that the pulsars “*might be part of a vast interstellar communications network which we have stumbled upon.*”²¹⁸

But scientists soon moved to close the door on this hypothesis, as one naturalist hypothesis after another was put forward to explain why pulsars behaved as they did. One of the early theories, that pulsars were radially pulsating white dwarf stars was discarded when it was found that two of the pulsars that had been discovered in the Crab and Vela nebula were actually remnants of supernovas, or exploding stars.³⁵ The model that was eventually decided upon and which became for a period the standard theory of pulsars is the “Neutron Star Lighthouse Model” as LaViolette calls it. Pulsars were

thought to be extremely dense rapidly rotating masses of *neutrons*, “neutron stars” which emitted beams of radiation called “synchrotron radiation” as they spun. This radiation is not so difficult to understand if one envisions the beam of a spotlight, rotating on its pedestal. When the rotation approaches one’s position, one sees the beam, until it rotates away, gradually dimming back into darkness, then gradually reappearing, and so on, only in the case of the pulsar, the beam is a radio wave of several frequencies.

This model worked well enough until astronomers discovered pulsars whose pulses were *not* regularly spaced, as they would be if the “lighthouse” model were true. The model had to be revised, and revised again, as more and more anomalous behavior was observed in pulsars. Against this history of failure to adequately explain the pulsar phenomenon on the basis of natural causes and models, then, LaViolette proposes in his book to revive the pulsars-as-nonrandomly placed, and as possible communications devices:

If extraterrestrial civilizations are attempting to communicate with us and are distinguishing their transmissions by doing “something that can’t be done in nature,” the pulsar signals certainly are the closest thing known to fit this criterion.

The chapters that follow present evidence that pulsars are nonrandomly placed in the sky, with particularly distinctive beacons being situated at key Galactic locations that are meaningful reference points from the standpoint of interstellar communication.²¹⁹

Evidence soon showed that pulsars originated from the surfaces of star-sized bodies, since many pulsars were known to have massive neighbors such as nearby stars or their own orbiting planets.²²⁰ This fact too, spelled the end of the idea that pulsars might be part of an artificially placed intra-galactic grid.

But not so fast, says LaViolette. He urges us do one of Einstein’s thought experiments and

Imagine a scientifically advanced civilization seeking out a hot stellar core and making use of its outgoing cosmic ray electron wind for communication purposes.

In this case, the star thus functions as a *gigantic particle accelerator*. Remember McCanney’s comets and the shot across the bow? In this case, the engineering *theory* at least, is simple:

By using advanced technology... magnetic fields might be artificially generated near the star’s surface that would, in turn, decelerate the star’s cosmic ray electrons and cause them to produce one or more beams of ...radiation.²²¹

Note that such a magnetic field might also be engineered to do another thing: it might be engineered to *accelerate* the star’s cosmic rays.

By placing several such fields near the surface of a star, several such beams could be directed to different locations. LaViolette reproduces the following diagram to illustrate his idea.

*La Violette's Model of Using A Star as a Source of Synchrotron Radiation By Engineering Fields near its Surface*²²²

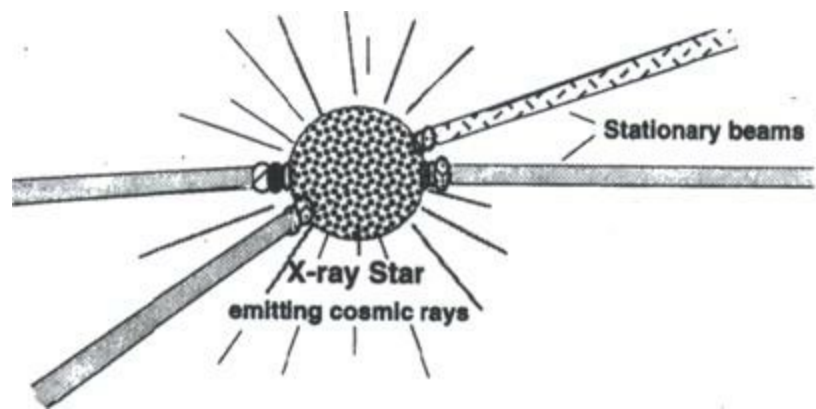

LaViolette then drops his bombshell: "In fact, a careful study reveals that pulsars are nonrandomly distributed in the plane of the sky in such a way that they point out a key location *relative to the Galactic Center*."²²³

La Violette then reproduces the following map which plots some 330 known pulsars on a map of the galaxy, with the center being the galactic center:

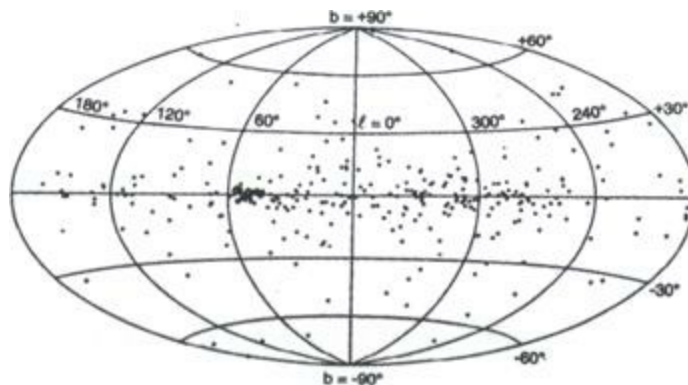

Note that the cluster of pulsars to the left of the galactic center should not be there if the pulsars were randomly placed. As LaViolette observes the center of this cluster "marks an angular deviation of *precisely one radian from the Galactic center*."²²⁴

What is a radian and why is this particular galactic longitude so special from the standpoint of extraterrestrial communication? The radian is a universal concept that comes from the study of geometry. Let us begin by drawing a circle... If we mark off a length along the circle's circumference that has the same length as the circle's radius, then the angle that subtends this arc, as measured from the center of the circle, is *one radian*. It takes a total of 2π radians to completely circumscribe a circle. Consequently, one radian will equal 36° divided by 2π , or about 57.296 degrees.²²⁵

So far so good.

But note that the cluster to the left of the galactic center diverges from the galactic center as *observed from Earth*. LaViolette then draws the first of many stunning conclusions:

By pointing out (this) one radian (location), the fabricators of this pulsar network, not only would be conveying to us that their signals are of intelligent origin... but also that their senders know the director of the *Galactic center as viewed from our solar neighborhood*.... Consequently, marking this one-radian location with a network of beacons would have meaning *only from our particular Galactic locale with its particular perspective for viewing the Galactic center direction.*²²⁶

But there is a problem with this concept, and LaViolette knows what it is.

Any “galactic communications grid” such as he is proposing is constrained by the “relativistic speed limit”: nothing can travel conventionally faster than the velocity of light. Thus, to construct such an array implies that anyone doing it would have to have a means both of communicating and traveling faster than light.²²⁷

However, while man has not done the latter (yet), he has already communicated faster than light:

In 1991, Thomas Ishii and George Giakos reported that they had transmitted microwaves a faster than light speeds. Shortly afterward in 1992, Enders and Nimtz, physicists at the University of Cologne in Germany, described transmitting *microwaves through an undersized waveguide at superluminal velocity*. This work became more widely known after 1995 when this group succeeded in transmitting Mozart’s 40th symphony through an undersized 11 centimeter long waveguide at a speed 4.7 times faster than that of light.²²⁸

Other experiments have involved the phenomenon of non-locality, and photon entanglement, to communicate information over great distances²²⁹ in violation of relativistic dogma.

But there were other, *earlier* attempts at communications, and here is where one begins, at last, to draw close to the connection between pulsars, the ancient war, and De Santillana’s and Von Dechind’s “galactic context” for ancient myths. La Violette produces the following diagram of a device built by the noted American “electro-gravitics” physicist Thomas Townsend Brown, the physicist whose name many will recognize as having been involved in the alleged Philadelphia Experiment.

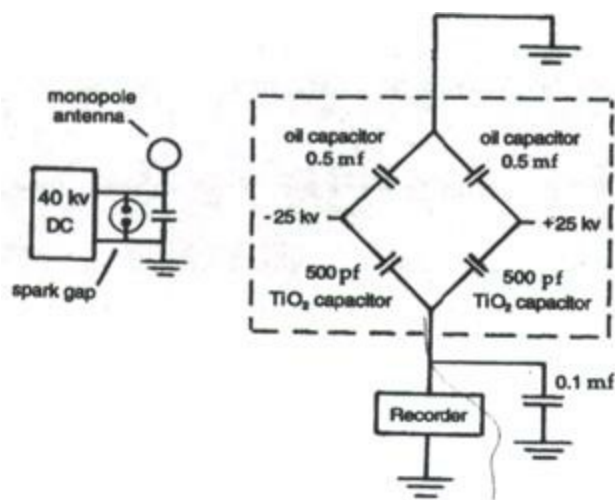

This was Brown's modification of similar experiments produced by Nikola Tesla, and relied upon the transmission of messages over great distances

By means of longitudinal wave shock fronts. (Brown's device) generated its signals by repeatedly charging a capacitor to a high-voltage and abruptly discharged it through a spark gap. The resulting energy shock fronts so produced were received by an electrified capacitor bridge that registered these waves as voltage transients read by means of a brush chart recorder. An investigator from the Office of Naval Research who witnessed a test of this device in 1952 *reported that signals were successfully transmitted to a receiver located in an adjoining room within an electrically grounded metal shield.* [230](#)

In other words, the receiver had been completely electrically shielded, and yet it registered the shock fronts! [231](#)

Because of this and other phenomena, Brown, like Tesla who had discovered a similar effect, began to suspect these longitudinal waves were superluminal, "although at the time he had no definitive proof of this." [232](#) But there was more:

Since he had determined that his capacitor bridge was able to detect gravitational disturbances, he concluded that the signals he was conveying must be gravitic, rather than electromagnetic. He reasoned that the waves were the gravitational homologues of light waves, which, for lack of a better word, he called "quasi-light." [233](#)

Brown discovered that he obtained even better reception if his original titanium oxide capacitors were replaced by ceramic capacitors with a "high mass density and high dielectric constant." [234](#) Note that the phenomenon is produced by standard electromagnetic components, the most important of which is a high energy direct *current pulse* across a spark gap. In short, one has similar components in a pulsar, and this leads Laviolette to ask the next important question: "Could the Hertzian electromagnetic emissions from pulsars contain a non-Hertzian superluminal component, as yet unidentified, that permits such rapid communication?" [235](#) In other words, was there a hidden longitudinal wave component in pulsars that was hitherto unrecognized? If so, then LaViolette's

thought experiment would be vindicated.

1. Back to the Myths: Sagitta, The Celestial Arrow

In order to trace down this and other possibilities for his pulsar hypothesis, LaViolette turns to ancient myths and the zodiac. As he observes,

We cannot help noticing a similarity between the pulsar clump and the ancient constellation of Sagitta which portrays the Celestial Arrow, both of which have their far tip situated near the Galaxy's northern one-radian point. In the case of the constellatory Arrow, the arrow tip is represented by the star Gamma Sagittae.... In fact, there is strong evidence to suggest that the ancient astronomers who outlined the Sagitta constellation knew the location of the Galactic center and purposely marked this one-radian point.[236](#)

In other words, the lore of constellations is oddly paralleled by an apparently non-random placement of pulsars one radian from the galactic center, as *viewed from the earth*. This implies that whoever "placed" the pulsars, and whoever initiated the lore of the zodiac in all its various permeations, may have been one and the same.

In any case, it is worth citing what LaViolette maintains this lore says:

A close study of constellation lore reveals that (Sagitta, the Celestial Arrow) is part of a larger constellation cipher, one that includes the southern constellations of Centaurus, and Crucis, as well as the constellations of the zodiac and their astrological lore. As explained in the author's books *Beyond the Big Bang and Earth Under Fire* these ancient asterisms and their associated lore use the language of metaphor to convey that the Galactic center underwent a major explosion and that cosmic rays and radiation from this outburst began to shower our solar system around 16,000 years ago, bringing about a global climatic disaster.... That is, according to star lore mythology, Sagittarius (The Archer) is aiming his arrow tip (Gamma Sagittarii) at the Heart of the Scorpion which is specifically represented by Alpha Scorpii, a bright red supergiant star.
[237](#)

In other words, we are now dealing not with exploding *planets*, but an explosion at the center of the galaxy, presumably involving one or several stars!

And note now the implications of what LaViolette has *almost* said: if the placement of the pulsar cluster to the left of the galactic center by one radian is not non-random, and is moreover only capable of being viewed this way from the Earth, and if the lore of constellations emanates from the same source as placed the pulsars in the first place, then perhaps the deliberate association of Sagittarius, a chimerical "person", aiming an *arrow or weapon at the galactic center* is a complex metaphor that the galactic explosion was itself an act in a war, the *same* cosmic war alluded to in other texts.

The implications of LaViolette's "pulsar hypothesis" are truly staggering, for it would take *thousands of years for the energy to travel roughly half way across the galaxy from its center to the Earth to impact its climate, since the galaxy is some 80,000 to 100,000 light years in width!*

This would require, in other words, any civilization as left these pulsar markers and zodiacal lore to have been very advanced technologically, and capable of warning its “Earth outpost” thousands of years ahead of the event!

But why associate this event with a real war at all? The answer lies in part of that astrological lore that LaViolette does *not* mention, and to answer it, we must return, for a moment, to De Santillana and Von Dechind’s *Hamlet’s Mill*, for there is also another constellation that is *also* a “hunter”, a “mighty man of renown,” and that constellation is Orion, “alias Nimrod.”²³⁸ Orion, of course, is associated with Egypt, and Nimrod was also the first “conqueror” who planned to build a “tower” that could “reach heaven,” a tower that had to be destroyed - according to the book of Genesis — because it would allow mankind to do whatever he imagined to do. This tower that could “reach heaven” was, as I have written elsewhere, no mere pile of bricks straining to reach great heights, but rather, a tower incorporating the celestial “plan” or geometry.²³⁹

But would such a civilization have the technology to cause an explosion of *that* magnitude?

Surprisingly, it is LaViolette who provides the disturbing answer. Noting that the two nebulae, Crab and Vela, remnants of supernovas or exploding stars, are not only uniquely placed relative to our solar system, but also two of the few nebulae that are marked by pulsars, LaViolette cautions that “we must look beyond merely the fact that they are uniquely placed relative to us.,”²⁴⁰ What one must look at, rather, is the fact that both nebulae, produced by the explosions of stars, “appear to have been triggered by the same Galactic superwave that was responsible for the major cataclysm at the end of the last ice age.”²⁴¹ This wave “first passed the relatively nearby Vela site, causing its supernova to occur, and then after traveling some 6300 light years further on, passed the Crab Nebula site causing its supernova also to occur.”²⁴² As for the mechanism that could have caused these two colossal explosions,

A particularly intense superwave could have coaxed the progenitor stars of these various remnants to explode if these stars were hot, inherently unstable, and embedded in a dust-laden environment. That is, upon their arrival, the superwave cosmic rays would overpower the star’s stellar wind and push nearby dust in close to the star. As the star begins to gravitationally draw this material onto its surface, the added kinetic energy would provoke its energy output to rise abruptly, whereupon the star would finally explode. *Alternatively, an advancing superwave might carry a steep gravitational field gradient that could induce frictional tidal forces sufficiently strong to energize the star and cause it to explode.*²⁴³

But then LaViolette raises a disturbing possibility: the Crab nebulae supernova might have been purposely engineered “by a highly advanced extraterrestrial civilization.”²⁴⁴ In other words, if one can engineer a star’s explosion, then one might have engineered the original galactic explosion as well, even though LaViolette does not maintain the latter! Again, in this context, it is important to recall that for De Santillana and Von Dechind, the *ultimate* context ancient myths is a *galactic* one; Tiamat herself, blown apart by Marduk in the epic of the *Enuma Elish*, may not only have symbolized a planet, but something far, far larger! Something truly cosmic.

But again, how might one actually *do* this? La Violette’s answer is chilling:

The technology required (for interstellar communication) is the same as that used in particle

accelerators employed by high-energy physicists for carrying out particle collision experiments. It is also the same technology used in a particle beam weapons systems such as those developed in the Pentagon's Star Wars program. Except in this case the technology would be employed for peaceful purposes.²⁴⁵

Star Wars indeed!

But recall that this would still limit one to the "relativistic speed limit" of the velocity of light, and this would be far too slow for interstellar communications, much less the ability to travel hundreds and thousand of light years to place the galactic pulsar "grid." So a modification is required

Which promises to vastly extend the present state of the art. This so called *beat-wave plasma accelerator* is able to generate 10,000 to 10 million times stronger than those used in the Stanford accelerator. *Two powerful laser beams of slightly differing frequencies are projected into a gas plasma tube to produce a "beat frequency wave" that moves through the plasma at tremendous speed.* Electrons "surfing" on this wave are then accelerated as the wave travels down the tube. A 10 meter long accelerator of this sort is theoretically capable of accelerating electrons to 100 billion electron volt energies.²⁴⁶

Note that what makes this accelerator work is the phenomenon of *interferometry*, and imagine what might happen if *masers* (microwave lasers), being squeezed through a waveguide that was too small, as was seen earlier, and interfered in a plasma, might then do. For after all, a star is but a big ball of plasma! And the "beat wave" is simply the interference wave set up by the *interferometry* in the plasma!

This is precisely where LaViolette goes:

Could a civilization possessing advanced field projection technologies perhaps even engineer an entire supernova explosion? By establishing a field bridge between the two poles of a star *and inducing a resonant electrodynamic oscillation between these two linked regions, the star might be induced to explode.* Clearly, a civilization must reach a high degree of maturity if it is to wield such a technology. While it could be very beneficial if put to the proper use, it could also be *used as a weapon of mass destruction if it fell into the wrong hands.*²⁴⁷

Indeed, such a weapon would be a one-shot method for taking out any putative civilizations based in a particular solar system. Take out the primary star, and one takes out the system and any life in it.

And this brings us finally to the actual nuts and bolts method that LaViolette proposes to do it with. The central component, as has been seen, is a "beat wave," produced by interferometry, in a plasma, such as a star. But how would one produce this "interference wave" in a star? After all, one would have to do it from a tremendous distance from the star itself, or risk being consumed in the stupendous explosion. The answer, not surprisingly, is with microwave utilization of the principles of optical *phase conjugation*, which is a principle, of course, of scalar physics.

The term "phase conjugation" refers to a special kind of "mirror" that is able to reverse the trajectories of the incident light waves and cause them to *precisely retrace the path they*

*followed to the phase conjugating mirror. The outcome is as if the photons had been made to travel **backward** in time.* If you shine a flashlight beam at an angle toward a regular silvered mirror, the beam will reflect off at an equal angle in the opposite direction. But if you angle a flashlight beam at a phase conjugate mirror, the returned beam will instead shine directly back at your flashlight!

Ok, but exactly *how* does this work?

It is extremely important that the reader note the details and conceptual components of LaViolette's summary of this principle that now follows, for they will become signally important in answering one of the most enduring questions of mythology from a paleophysical point of view.

Optical phase conjugation is most commonly known for its use in military laser weapons systems for destroying enemy missiles. In this application, a laser beam *is directed at a distant moving missile target and light rays scattered back from the target are allowed to enter the phase conjugator, a chamber containing a medium having nonlinear optical properties. In this nonlinear medium, the scattered rays interact with two opposed laser beams of similar wavelength to form a hologram-like electrostatic light refracting pattern called a "grating."* Once this grating pattern is formed, the system has essentially locked onto its target. A powerful laser weapon is then discharged into this holographic grating pattern, whereupon the coherent laser light reflects (from the grating) in such a way as to produce an intense outgoing laser beam that retraces the paths that had been followed by the incoming rays that had originally been scattered from the missile. Consequently, the outgoing laser pulse converges precisely back onto its missile target. [248](#)

Bearing in mind that plasma is one such "nonlinear medium," we may now see what optical phase conjugation is, and why it was used in the Star Wars program, both the modern one, *and the ancient one.* [249](#)

Phase conjugation is best understood by breaking down its components into steps or stages:

1. A coherent beam of electromagnetic energy is aimed at a target, which beam is reflected *back* to the transmitter.
2. The returning beam is then split in a non-linear medium and interfered in it, which creates the "grating", or, as Lt. Col Tom Bearden would put it, a "template" for action. The reason that an interference pattern is created is that *the atmosphere distorted the returning or reflected beam, thus making it of slightly different frequency from the outgoing wave.*

And here an important comment is necessary. Vacuum space is also both a wave *propagating* and wave *distorting* medium, for as the rotating version of the famous Michelson-Morley experiment of French physicist Georges Sagnac demonstrated, a split beam of light fired in opposite directions in a rotating system and then interfered produces precisely such a grating or interference pattern, demonstrating a local effect of an "aether drag." But what would be the best way of detecting an interference grating for a target many millions of miles distant, where electromagnetic waves would have to travel to and back from an object through vacuum space? Here recall the rotating plasmas, or plasmoids of chapter two, and one has the answer: *the non-*

*linear medium par excellence for forming a grating that results from reflecting a beam through the wave-distorting medium of spaces would be a quickly rotating plasma. A further consequence of this view should also be noted, for this means that stars are natural phase conjugate mirrors of local stellar- system spaces.*²⁵⁰ Once one has the concept of phase conjugation and the nonlinear interference grating “capturing medium” of rotating plasma, one has the two essential ingredients for any such “scalar” weapon as La Violette proposes.

3. Once this grid or interference pattern is created, the actual “punch” or energetic pulse of the weapon is fired *through the “holographical” grating which then reverses the effect of the intervening distorting medium, and thus the main punch arrives at its target perfectly cohered and in perfect resonance with its target, since the “grating” is the signature of that target and that target only.*

We now return to LaViolette, who proposes a “Mark II” version of phase conjugation, this time, not with cohered electromagnetic energy in the visible spectrum, but in the radio and microwave frequencies:

Consequently, it should be possible to phase conjugate microwaves by following techniques similar to those described in experiments with an optical phase conjugation. However, it appears that most of this research is still highly classified. While many papers have been published on optical phase conjugation, virtually no literature is available on the application of phase conjugation at microwave frequencies.²⁵¹

And if LaViolette can propose microwave phase conjugation as a kind of Mark II, “power upgrade” of optical phase conjugation, it is not difficult to see that the next step, Mark III, would be *X-ray* and *gamma ray* phase conjugation.

LaViolette produces this simple schematic of his microwave phase conjugate mirror (next page):

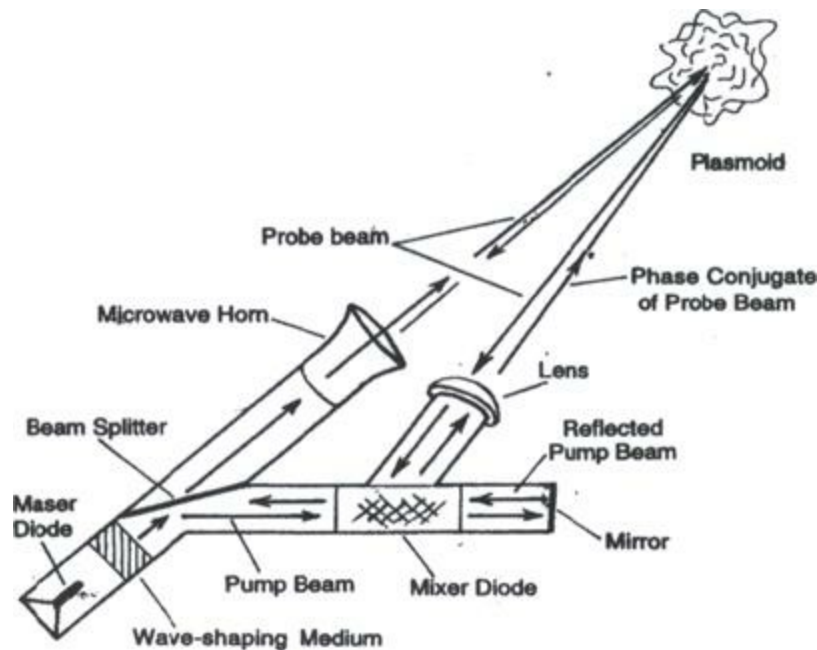

LaViolette then comments at length as follows:

...suppose that a bank of high-voltage capacitors are suddenly discharged to momentarily create a powerful air ionizing arc, or regularly shaped plasmoid. Also, suppose that a beam of coherent microwave radiation from a maser is targeted on this plasmoid. This beam would be sent out by a phase conjugating device something like that pictured... This device splits the original maser beam into two beams, *a probe beam* and a *pump* beam. The probe beam is directed toward the plasma target, and some of its scattered microwaves shine back toward the phase conjugator device and enter its *mixer* chamber. The mixer chamber is filled with a medium that has very nonlinear electromagnetic properties. Meanwhile, the pump beam that is split off from the maser generator is directed to the adjoining mixer chamber where it passes through the nonlinear mixer medium, reflects from a wall at the far end, makes a second pass back through the mixer medium, and then reenters the maser generator compartment.

The microwaves that scatter from the plasmoid and enter the mixer medium strongly interact with the two pump maser beams to form an electrostatic grating pattern. This holographic pattern stores information about the directions and phases of all the scattered maser beam microwaves that have entered the mixer. The counterpropagating pump beams then reflect from this grating pattern to produce an outgoing microwave beam that *precisely traces the paths followed by the incoming scattered waves... the randomizing effects of wave scattering having been automatically compensated for.*

...The grating that performs this time-reversed reflection is called *a phase conjugate mirror* and the mixing arrangement that allows all this to happen is termed *a four wave mixer*.This closed loop path from the maser beam generator, to the plasmoid, to the mixer, to the plasmoid, and back to the maser beam generator, causes the maser system to function as *a phase conjugate resonator* and to *preferentially select and amplify only those microwaves that target the phase conjugating mixer chamber*. As a result, most of the microwave power emitted from the maser will end up being confined to a beam that extends between the maser beam generator, the plasmoid target, and the mixer chamber. The energy bottled up in this beam will then progressively build up to a very high value. [252](#)

One might therefore be able to scale this version of things up considerably, and use a star itself as the target “plasmoid,” as LaViolette previously suggested.

But one might go beyond even the gamma and X-ray “Mark III” versions of this phase conjugate star-busting “Mark II mirror.” One might be able to envision using those very longitudinal “electro-acoustic” waves themselves in such a device.

In any case, with the “galactic context” of De Santillana, Von Dechind, and La Violette, it is now clear why the sinking of Atlantis and the wars of the gods have to be understood as involving more than just a lost continent on our tiny planet. For if LaViolette’s galactic explosion and superwave, or if the explosions of Van Flandern’s two exploded planets, were acts in a war, an act fought by an extremely advanced society having access to such star and planet busting phase conjugate mirrors, or “scalar” weapons, and having access thereby to non-local and superluminal means of travel and communication, then Atlantis, and Tiamat were not, per Alford’s reading, merely metaphors of a planetary “mountain” or “island” in the midst of an “ocean” of space, nor, following other readings,

was the lost continent merely a “continent” or that sank some 10,000 years ago beneath the seas here on earth, a distant victim in time and space from that original galactic explosion.

But even if this galactic context should not ultimately prove to be a component of the war scenario, the evidence thus far presented would seem to indicate that at least *one* such celestial explosion, even a relatively “small” one of a “small” celestial body, was a gruesome act in a brutal cosmic war.

So perhaps the war motif is, on the contrary, true, for as all the physics of LaViolette and Bearden, and so many others indicates, we are on the cusp of reconstructing the very technology and weapons that made that war possible. And if this physics sophistication mirrors an ancient application of similar principles, it should not surprise us then that we are also (re-)developing sciences and technologies in other areas, to genetically engineer and alter the biology of human life itself to prolong it abnormally, the same technologies and sciences which are now allowing us, like the gods of old, once again to dream of terrible chimeras and hybrids: to grow human ears on rats today, and perhaps half-human half-animal chimeras, centaurs, and gryphons, and fish-men and serpent-men tomorrow.

We have found the physics for the weapons, and seen evidence of their use in physics theories and ancient petroglyphs, art, and artifacts. We have found the general time periods in which it occurred both in modern theory and ancient text, and the debris that it left behind, and we intuit, in our inmost being, that planets unlike stars simply do not spontaneously explode. And we have learned from LaViolette that some stars may not have spontaneously exploded either. We have seen the gigantic mummies and read the reports of giants, distant cousins, perhaps, of some lost race on a lost and exploded world and - with their great height, their double dentition and sexedigitism - skeletal contradictions to our sense of the “normal” and regular.

But who was fighting?

And why?

And who won? Who lost?

And who were the “good guys” and the “bad guys”? And *why* were they good? Or conversely, bad, beyond the obvious evil of deliberately blowing up a planet or two — or worse, a star - and flooding a couple of others with oceans of water and debris?

We can no longer ask the physicists — or for that matter, the geneticists or biologists — to lead the way here. At best they can provide us corroborating evidence or unique insights into the ancient story of this war. But beyond answering certain specific things one encounters in the ancient texts that tell this story, these sciences and technologies can show us only that intelligent life is able to be behind these things and to fight such a war, and that the story need not be merely metaphors for an accidental cosmic game of billiards in which mankind is stuck helplessly on the balls.

To ask the questions at all is to turn to the ancients and their texts for the answers.

6.

CONCLUSIONS TO PART ONE

“The clamour has deafened me and I feel stupefied. The twang of the Gandiva, like repeated thunderclaps, and your lightning bolt arrows have rent my heart. I am consumed by fear. It appears as if the earth is shifting before my eyes and I am losing my vitality. ”

The Mahabharata [253](#)

“In their shining armor the fighters appeared like two planets colliding. ”

The Mahabharata [254](#)

We are now in a position to summarize some very suggestive connections.

1. There were *two planetary explosions* within our solar system, and these two events form the basic framework around which to fasten any chronology distilled from the ancient texts relating the cosmic war;
 - a. The first of these was the explosion of a larger body, some 65,000,000 years ago, that accounts for the formation of the K/T boundary in the geological records, and coinciding with the demise of the dinosaurs and the rise of mammalian life;
 - (1) As was seen, Van Flandern was led to the adoption of two explosions on the basis of the lack of a planetary geological layer, such as the K/T boundary, occurring in rock strata ca. 3,200,000 years ago;
 - (2) As I suggested, however, the explosion ca. 3,200,000 years ago may have occurred when the Earth was at its farthest point from the exploding body, and hence any shock wave would have been considerably dissipated.
 - b. The second of these was the explosion of a smaller body ca. 3,200,000 years ago.
2. According to Van Flandern, these two explosions at 3,200,000 and 65,000,000 years ago were the explosions of a smaller “moon-sized” body and a larger Saturn-sized planet, respectively;

- a. This planet Saturn-sized body was in all likelihood a solid and water-bearing planet. This planet may have been the planet referred to in the ancient Babylonian epic, the *Enuma Elish*, as Tiamat.
 - b. As a water-bearing planet, this body might have been a life-sustaining planet, and possibly home to intelligent human-like or humanoid life as well.
 - c. If it was home to intelligent life, it was speculated that this creature would have had much larger physiologies and skeletal structure compared to modern *homo sapiens sapiens*. In short, these creatures would have been giants. Given the interaction between the “gods” and mankind that so many Mesopotamian texts and traditions — including the biblical — attest to, and their resulting offspring in “giants,” one method of loosely corroborating the existence of such life on the now missing and exploded planet, and its interaction with the earth, would be the discovery of giant humanoid fossilized remains, or acceptable testimony to the same.
 - d. As was seen in chapter four, there does exist a whole set of data, both of written testimony, plus fossilized or mummified remains, that attests to the existence of much-larger-than normal humans or human-like creatures.
 - (1) As noted, many of these testimonies report peculiar features, such as sexedigitism and double dentition;
 - (2) Many of these ancient testimonies record the aggressive and cannibalistic tendencies of these creatures.
3. Plasma physicist Anthony Peratt argues that some ancient petroglyphs — some dating to over 20,000 years ago — demonstrate remarkable accuracy in the depiction of standard plasma instabilities, and reasons that ancients must have witnessed such instabilities on a massive celestial scale thousands of years ago.
- a. In arguing this point of view, Peratt poses the problem of the existence of intelligent observers of such events.
 - b. Peratt and other plasma cosmologists maintain that under certain conditions any celestial system such as the solar system is not electrically neutral, and that enormous discharges can occur between differently polarized planetary bodies, causing enormous scarring and searing of the planets’ surfaces.
 - (1) In this respect, the Hygenius Rille on the Moon, and
 - (2) The channels on Jupiter’s moon Europa, and
 - (3) The Valles Marineris were all cited as typical large scale planetary features that display the same features of “plasma drilling” caused on surfaces in the laboratory.
 - (4) As was also demonstrated, the Martian scarring in particular may be planetary confirmation of the mythological motif of the scarred warrior, given Mars’ association within so many disparate mythologies with war, and given the planetary scarring

referred to above.

4. It was suggested in chapter two that this plasma physics might itself be weaponized, and thereby account for the ancient myths of the divine weapon as a “lightning” bolt. In this respect, the similarity of ancient art works depicting these divine weapons with modern plasma instabilities was demonstrated.
 - a. An entirely different use of plasmas for communications - in the form of a galaxy-spanning *grid* of stars and pulsars - was proposed by Paul LaViolette. La Violette points to the anomalous behavior of pulsars and the lack of a good physics model to explain not only their behavior, but their non-random clustering in an exact geometry of one radian from the center of the galaxy as *viewed from Earth*. This non-randomness argues strongly that they may be the technological products of a highly advanced, galaxy-spanning civilization.
 - b. However, LaViolette also observes that there is a weapons application of this technology, related specifically to the scalar physics phenomena of beam splitting and mixing through an interferometric “grating” or template, and the use of a phase conjugate mirror. This implies that weapons drawing upon the very energy of entire stars or even star systems can be stimulated and accessed by the phenomenon of phase conjugation. This fact, coupled with the galaxy-wide “grid” of LaViolette’s “pulsar network” would imply that any warfare using such weapons would draw upon and affect that entire grid. It would be, in short, a truly *cosmic* war.
 - c. The link to scalar physics implies a deeper physics, one of longitudinal waves in the medium itself, as LaViolette himself suggested, citing the work of Lt. Col. Tom Bearden. Such waves could conceivably be used as propulsion, or also used to “surf” large scale celestial objects such as comets or asteroids on collision courses with planets, or used to explode a celestial body such as a planet or star by means of acoustic loading and cavitation to the point that such bodies lose core stability and explode. LaViolette himself proposes that some stars were deliberately exploded by his putative galactic civilization as components in his galactic grid.

5. Finally, the examination of catastrophism showed that it was in contradiction to the type of dense punning found in most ancient myths and motifs. Such symbols, it was argued, were best viewed not as symbols indicating one level of meaning, but several levels, each interlocking, but not identifiable with, the other, in a complex of associations. Among these associations, we discovered a formula

Mountains \approx planets \approx gods,

where “ \approx ” means “is closely associated with but not identical to”, that will now become a crucial complex of symbols in Part Two.

PART TWO:

THE QUESTIONS: WHO FOUGHT? WHY WERE THEY FIGHTING? WHO WON? WHO LOST? WHAT HAPPENED?

*“WE ARE THE LOST ONES
From a Time before Time
From a Land beyond the Stars
From the Age when ANU walked the earth
In company of Bright Angels.
We have survived the first War
Between the Powers of the Gods
And have seen the wrath of the Ancient Ones
Dark Angels
Vent upon the Earth.*

*WE ARE FROM A RACE BEYOND THE
WANDERERS OF NIGHT.*

*We have survived the Age when ABSU ruled the Earth
And the Power destroyed our generations....
And TIAMAT has promised us nevermore to attack
With water and with wind....
Know that our years are the years of War
And our days are measured as battles. ”*

From the Magan Text of the Babylonian Necronomicon,
“Simon,” ed., *The Necronomicon*, (Avon), pp. 159-160.

REVOLT AND WAR IN THE PANTHEON: A LOT OF WHO, A LITTLE WHY, SOME WHAT, AND A HINT OF WHEN

‘We incline to the opinion that experiences of a far distant past lie at the heart of the Edfu myth of creation. ’

E. A. E. Reymond[255](#)

*“Was it possible therefore that the world once possessed an understanding of sound that was lost and **never** recovered?”*

Andrew Collins[256](#)

“For years Keely attempted to find a way to by-passing the personal association of the apparatus to its operator but in this he failed again and again. ”

Andrew Collins[257](#)

What sparked this horrendous War in the Pantheon, protracted for seemingly endless millennia, and fought with such horrific technologies?

It is a peculiarity that among the three main legacy civilizations of the ancient world, the Sumerian, the Egyptian, and the Vedic, that each of them maintains that it was fought in part to recover stolen technology, the very technology with which the war was fought. Additionally, there is unusual corroboration of the main outlines of this story from across the oceans in the Americas.

A. The Sumerian Version

As is to be expected, the Mesopotamian tradition is rich with details concerning the revolt in the Pantheon, the war, and the motivations for it. These motivations may be broadly classified into two types, the “Mankind Motivation,” and the “Technological Motivation.” In this chapter, our focus is on the first motivation. The technological motivation will be discussed in the next chapter.

There are three main texts that tell the story of who was involved in the revolt, why they were involved, what happened, and that give an indication of when it happened. These are the *Atrahasis Epic*, the legend of *Erra/Nergal and Ishum*, and the well-known *Sumerian Kings List*. In this section we shall be concerned with the first two, reserving our comments on the *Sumerian Kings List* for a later section of this chapter.

1. *The Atrahasis Epic*

The oldest clay tablets containing the Flood Epic of Atrahasis “can be dated around 1700 BC.”²⁵⁸ The entire focus of the epic is on the relation of mankind, called the “Igigi” in the text, and the gods, a relationship that leads ultimately to the gods’ extermination of mankind whom they had helped create.

The story begins with an overview of the plot that will be unfolded in more detail as the myth proceeds:

When the gods instead of man
Did the work, bore the loads,
The gods’ load was too great,
The work too hard, the trouble too much.
The great Anunnaki made the Igigi
Carry the workload sevenfold.
Anu their father was king,
Their counselor warrior Ellil,
Their chamberlain was Ninurta,
Their canal-controller Ennugi,
They took the box [of lots]....,
Cast the lots; the gods made the division.
Anu went up to the sky,
[And Ellil(?)] took the earth for his people (?)... ²⁵⁹

They were counting the years of loads.
For 3,600 years they bore the excess,
Hard work night and day.
They groaned and blamed each other,
Grumbled over the masses of excavated soil;
“Let us confront our [] the chamberlain,
And get him to relieve us of our hard work!
Come, let us carry [the Lord (?)],
The counselor of gods, the warrior, from his dwelling...”²⁶⁰

As these passages make clear, the “gods” were near open revolt due to the exorbitant workload laid on them, and they demand to see the “chamberlain.”

A little later on in the text, the revolt or strike threatens to become open war:

“Every single one of us gods declared war!
We have put [a stop] to the digging.

The load is excessive, it is killing us!
Our work is too hard, the trouble too much!
So every single one of us gods
Has agreed to complain to Ellil.”²⁶¹

As Zechariah Sitchin has often pointed out, in the face of this situation, the gods decided to ease their workload by creating an intelligent “worker,” mankind:

Ea made his voice heard
And spoke to the gods his brothers...

...

“There is []
Belet-ili the womb goddess is present -
Let her create primeval man
So that he may bear the yoke [()],
So that he may bear the yoke, [the work of Ellil],
Let man bear the load of the gods!”²⁶²

Mankind’s “purpose in life was to relieve the gods of hard labour,”²⁶³ he was, in short, created to be a slave.

A little later on, the exact, and grizzly, methods of the creation of mankind are described in detail:

Enki made his voice heard,
And spoke to the great gods,
“On the first, seventh, and fifteenth of the month
I shall make a purification by washing.
Then one god should be slaughtered.
And the gods can be purified by immersion.
Nintu shall mix clay
With his flesh and his blood.
Then a god and a man

Will be mixed together in clay.
Let us hear the drumbeat forever after,
Let a ghost come into existence from the god’s flesh,
Let her proclaim it as his living sign,
And let the ghost exist so as not to forget (the slain god).”

They answered “Yes!” in the assembly,
The great Anunnaki who assign the fates.²⁶⁴

The decision made, the “gods” then proceed to the task of slaughtering one of their own and creating “primeval man.”

On the first, seventh, and fifteenth of the month
He made a purification by washing.
Ilawela who had intelligence,
They slaughtered in their assembly.
Nintu mixed clay
With his flesh and blood.
They heard the drumbeat forever after.²⁶⁵

This gives a crucial insight into the “morality” of the Annunaki, who are clearly not above murdering one of their own to lighten the workload of the rest.

But the passage is obviously pregnant with much more significance. As Assyriologist Stephanie Dalley observes:

This account of man’s creation may be compared with that in the *Epic of Creation*, in which Marduk used the blood of Qingu, the evil leader of the enemy gods whom he had slain, to create mankind with the help of Ea; clay is not mentioned, and no birth-goddess takes part, but the purpose of man’s creation is again to toil on the gods’ behalf.

...

The account in Genesis describes God using earth (adamah) to create the first man (Adam) animating him with the breath of life.²⁶⁶

The ancient Mesopotamian account of the creation of man, in other words, appears generally of a piece with the biblical account in so far as common clay or dirt is mingled with the “life” of God or the “gods”: in the case of the Hebrew version, with the “breath of life,” and in the *Atrahasis*, the blood of life.

But here the resemblance stops. Beyond the obvious moral differences between the two accounts, the Mesopotamian version of mankind’s creation also hints at something else: mankind is a *chimera*, a *hybrid*, engineered by mingling the “gods” with *an already existing “man:”* “Nintu shall mix clay With his flesh and his blood. / Then a god and a man / Will be mixed together in clay.” Zechariah Sitchin believes that this is an indicator of a sophisticated “paleoscience” of a very different sort: advanced genetic engineering and manipulation.

For the theologically inclined, these observations suggest a method of reconciliation between the Mesopotamian and the Biblical traditions, for if there was an already existing human or human-like creature from which “primeval” worker-man was engineered, as the *Atrahasis* suggests, then the biblical account in Genesis would appear to be referring to this creature, while its subsequent mention of the creation of a hybrid race brought about by the intermarriage of the *Nephilim* and the daughters of men in Genesis 6 would then be the hybrid race referred to here as the creation of man by the gods in the *Atrahasis*. More on this point in a subsequent chapter.

That this is a plausible reconciliation is borne out by what immediately follows in the

Mesopotamian epic:

Far-sighted Enki and wise Mami
Went into the room of fate.
The womb-goddesses were assembled.
He trod the clay in her presence;
She kept reciting an incantation,
For Enki, staying in her presence, made her recite it.
When she had finished her incantation,
She pinched off fourteen pieces (of clay),
(And set) seven pieces on the right,
Seven on the left.
Between them she put down a mud brick.
She made use of (?) a reed, opened it (?) to cut the umbilical cord,
Called up the wise and knowledgeable
Womb-goddesses, seven and seven.
Seven created males,
Seven created females.²⁶⁷

In other words, the resulting race of “primeval man”, of “worker man” was a hybrid of the gods and whatever “man” had already existed as the “clay” from which the new man was created. This roughly parallels the account of the *Nephilim* in Genesis 6.

But there is another extremely important connection between the two traditions that should not be overlooked, and like all such things, it is easy to do because it is so obvious. Both the *Atrahasis* account of the creation of this hybrid “worker” man and the Genesis account of the Nephilim and their hybrid offspring form the immediate context for their respective versions of the Deluge.

The *Atrahasis* legend, however, puts the motivations for the Deluge in starkly different terms, for it is not this new hybrid race’s utter lack of morality that is the reason for the Deluge, as it is in the biblical account, it is rather this new race’s *longevity and the resulting overpopulation of the earth by a hybrid “mankind”*:

And the country became too wide, the people too numerous.
The country was as noisy as a bellowing bull.
The God grew restless at their racket,
Ellil had to listen to their noise.
He addressed the great gods,
“The noise of mankind has become too much,
I am losing sleep over their racket.”

Ellil orders that the population be reduced by introducing a deadly disease among hybrid population:

“Give the order that *suruppu*-disease shall break out...”²⁶⁸

Dalley's comment is worth citing:

In *Atrahasis* the Flood was sent by the gods in order to reduce overpopulation, a situation which has been compared with an early Greek poem, the *Cypria* (loosely attributed to Homer in antiquity and known mainly from allusions and quotations), in which Zeus planned to reduce overpopulation by war. [269](#)

In any case, one individual of the new hybrid race, for whom the epic is named, Atrahasis, beseeches his "god" Enki to do something about "humanity's" plight:

Now there was one Atrahasis
Whose ear was open (to) his god Enki.

...

Atrahasis made his voice heard
And spoke to his lord,

“How long (?) [will the gods make us suffer]?
Will they make us suffer illness forever?”

Enki's response to Atrahasis is that he should foment a rebellion against all the gods, and strike, refusing to work, returning the pantheonic council to the same situation that led to the creation of the hybrids in the first place:

Enki made his voice heard
And spoke to his servant:

“Call the elders, the senior men!
Start [an uprising] in your own house,
Let the heralds proclaim..
Let them make a loud noise in the land:
Do not revere your gods,
Do not pray to your goddesses... [270](#)

The result, however, is a replay of what brought about the disease in the first place, as Enlil decrees that the hybrid man should be starved to death to reduce the overpopulation:

The God grew restless at their clamour,
Enlil had to listen to their noise.
He addressed the great gods,

“The noise of mankind has become too much.
I am losing sleep over their racket.
Cut off food supplies to the people!

....

Command that Anu and Adad keep the (air) above (earth) locked,
Sin and Nergal keep the middle earth locked.“[271](#)

Interestingly, the “god” of wars, rebellions, of Mars and of the Underworld, Nergal, is involved in this nefarious activity.

As a result of this new assault, which according to the legend lasted for six years, the hybrid “man” was reduced to cannibalism:

A daughter would eye her mother coming in;
A mother would not even open her door to her daughter.
A daughter would watch the scales (at the sale of her) mother,
A mother would watch the scales (at the sale of her) daughter.
When the sixth year arrived
They served up a daughter for a meal,
Served up a son for food.[272](#)

But even this brutality did not work.

Finally a council is held, and Enlil/Ellil complains that the plan to create the hybrid worker race did not work, and he quickly proceeds to blame the god who has “befriended” mankind, Enki:

He (Ellil) was furious [with the Igigi][273](#)

“We, the great Anunna, all of us,
Agreed together on [a plan].

Anu and [Adad] were to guard [above],
I was to guard the earth [below].
Where Enki [went],
He[274](#) was to undo the [chain[275](#) and set (us) free],
He was to release [produce for the people].[276](#)

An argument quickly develops between Ellil/Enlil and Enki:

“[You] imposed your loads on man,
You bestowed noise on mankind,
You slaughtered a god together with his intelligence.
(Ellil to Enki): You must... and [create a flood].
It is indeed your power that shall be used against [your people!][277](#)
You agreed to [the wrong (?)] plan!
Have it reversed! (?)

Let us make far-sighted Enki swear... an oath.”

Enki made his voice heard
And spoke to his brother gods,

“Why should you make me swear an oath?
Why should I use my power against my people?
The flood that you mention to me -
What is it? I don’t even know!
Could I give birth to a flood?
That is Ellil’s kind of work!

....

[Let Erakal²⁷⁸ pull out] the mooring poles
Let [Ninurta] march, let him make [the weirs] overflow.²⁷⁹

Enki, in other words, will have no part in wiping out the new race.

Indeed, Enki actually warns Atrahasis of the impending genocide:

Enki made his voice heard
And spoke to his servant,

....

“Dismantle the house, build a boat,
Reject possessions, and save living things...”²⁸⁰

Then, the Deluge breaks over mankind.

Anzu was tearing at the sky with his talons,

....

...the Flood [came out (?)].

The *kasusu*-weapon went against the people like an army.

No one could see anyone else,

They could not be recognized in the catastrophe.

...

The darkness was total, there was no sun.²⁸¹

Notably it is Anzu that is credited with bringing the Flood. As will be seen in the next chapter, this is the same Anzu that wages war with the rest of the Pantheon by stealing the Tablets of Destinies, making it likely that the Flood, the decision to wipe out mankind, and the war in the Pantheon, are all somehow components of the same scenario.

It is clear from the *Atrahasis* however, that at least one motivation for the Deluge, as far as the Mesopotamian tradition is concerned, is the overpopulation of the earth by the new hybrid race.

Reading between the lines a bit, it is possible that the pantheon perceived the growing population as a threat to its own power, a reading borne out by the argument between Enlil and Enki, for perhaps inflicting the catastrophe on the hybrid race was the pantheon's "loyalty test" on Enki. This would imply that perhaps Enki's seeming beneficence to Atrahasis and the human race was just that: *seeming* beneficence. Perhaps he had plans to use the revolt among the human workers to further his own power.

In any case, it seems that the *Atrahasis* is more than a mere epic, for it hints at dark designs and agendas at work in the pantheon, and moreover clearly suggests that mankind, whether in his hybrid form or not, is perhaps both battlefield and prize in a much larger cosmic conflict.

2. *The Legend of Erra/Nergal and Ishum*

The second major Mesopotamian text that bleakly hints at this central role of mankind in the conflict is the *Legend of Erra and Ishum*. Before proceeding to the text itself, it should be noted that “Erra” is but another name for Nergal, and thus the legend not only gives significant insights into the “mankind motivation” for the war, but also into the dubious character of Nergal himself, in all his miserific glory.

The *Legend of Erra and Ishum* begins with the creation of the seven “sebitti”, the seven sages-and-warrior gods given to Nergal as his “fierce weapons.” These “seven sages” are critical players in the conflict. Their importance, in fact, is underscored by the *Erra and Ishum* itself, for they council Nergal into total and open revolt, and to seek absolute power:

‘Go out to the battlefield, warrior Erra, make your weapons resound!
Make your noise so loud that those above and below quake,
So that the Igigi hear and glorify your name,
So that the Anunnaki hear and fear your word,
So that the gods hear and submit to your yoke,
So that kings hear and kneel beneath you,
So that countries hear and bring you their tribute,
So that demons hear and avoid (?) you,
So that the powerful hear and bite their lips.’

...

Warrior Erra listened to them.

The speech which the Sebitti made was as pleasing to him as the best oil.^{[282](#)}

One god, Ishum, steps forward to council Nergal against open revolt and war:

When Ishum heard this,
He made his voice heard and spoke to the warrior Erra,
“Lord, Erra, why have you planned evil for the gods?
You have plotted to overthrow countries and to destroy their people, but will you not turn back?”^{[283](#)}

Undeterred, Nergal resolves to assault the king of the gods, Marduk himself, and actually confronts Marduk personally.

Marduk’s response is to remind Nergal of his power, by reminding him how he destroyed Tiamat and *rearranged the very mechanics of heaven itself*:

The king of the gods made his voice heard and spoke,
Addressed his words to Erra, warrior of gods,

‘Warrior Erra, concerning that deed which you have said you will do:

A long time ago, when I was angry and rose up from my dwelling and arranged for the flood,

I rose up from my dwelling, and the control of heaven and earth was undone.

The very heavens I made to tremble, the positions of the stars of heaven changed, and I did not return them to their places.

Even Erkalla quaked....

Even the control of heaven and earth was undone... “[284](#)

At this juncture, it is worth citing at length what I wrote concerning the Babylonian creation epic, the *Enuma Elish* in my book *The Giza Death Star Destroyed*.

a. Revisiting the Enuma Elish

“...The Babylonian creation epic, the *Enuma Elish*, presents a concise though quite suggestive account of this interplanetary rebellion and war. The principal characters... are the “gods” Tiamat and Marduk.

(1) The War as a Rebellion

“The account begins as a creation account in rather typical fashion for an ancient text, recounting a state of initial chaos from which, through conflict of opposites, the order of creation gradually emerges:

1. When in the height heaven was not named,
2. and the earth beneath did not yet bear a name,
3. and the primeval Apsu, who begat them,
4. *and chaos, Tiamat, the mother of them both -*
5. *their waters were mingled together,*
6. and no field was formed, no marsh was to be seen;
7. when of the gods none had been called into being;
8. *and none bore a name, and no destinies [were ordained]... [285](#)*

Note that the first state or condition of creation is an undifferentiated state, or “chaos,” a condition recalling physicist LaViolette’s hermeneutic examined in my first book, *The Giza Death Star*.²⁸⁶ This undifferentiated state would best be described by our modern physics terms of “vacuum”, “zero point energy”, “quantum flux” or even “medium” or “aether.” The occurrence of the concept here, prior to the appearance of any distinctive objects of creation, is a strong indicator that the document preserves a residue of an earlier more sophisticated “paleophysical” cosmology. This is corroborated by the absence of names - “and none bore a name, and no destinies [were ordained]” - indicating in another fashion the absence of physically distinct and observable characteristics, corroborating the idea that we are dealing with a document of cosmological physics guised in a religious text.

“This might suggest that the proper names for the “gods” would argue against the “titular” *pars pro toto* rhetorical usage advocated by Laurence Gardner. As will be seen, however, the association of “Tiamat” with chaos and destruction subsequently in the *Enuma Elish* may be an artifact of the role of actual persons in the war described subsequently in the epic. In fact, the indicator of this war occurs almost immediately after the opening verses cited above, strongly suggesting that the conflict was a very ancient one:

22. But T[iamat and Apsu] were (still) in confusion [...],

23. They were troubled and [.....]

24. In disorder(?)..[.....]

25. Apsu was not diminished in might[....]

26. and Tiamat roared[.....]

27. She smote, and their deeds [.....]

28. Their way was evil..[.] ²⁸⁷

“Notwithstanding the deteriorated condition of the tablets from which the text is translated, there are clear indications that Tiamat and Apsu were real persons, since they are engaged in activities perceived as *evil*. Soon after this, the epic gives the reason for this moral assessment:

49. Come, their way is strong, but thou shalt destroy [it];...

...

51. Apsu [hearkened unto] him and his countenance grew bright,

52. [Since] he (i.e., Mummu) planned evil against the gods his sons.²⁸⁸

“Note again the personalism of the document, as well as the fact that the war appears to be a “family quarrel” that has erupted into a civil war, a reading well in line with Zecharia Sitchin’s reconstructions. Many of the “gods” quickly flock to Tiamat’s side.

“At this juncture, the epic becomes very specific - unusually specific in fact, for a mere “creation epic” - in cataloguing the weapons used by the “Tiamat alliance”:

109. [They banded themselves together and] at the side of Tiamat [they] advanced;

110. [They were furious, they devised mischief without resting] night and [day].

111. [They prepared for battle], fuming and raging;

112. [They joined their forces] and made war,

113. [Ummu-Hubu}, who formed all things,

114. [made in addition] *weapons invincible, she spawned monster serpents,*

115. *[sharp of] tooth, and merciless of fang;*

116. *[with poison instead of] blood she filled [their] bodies.*

117. Fierce [monster-vipers] she clothed with terror....

...

120. Their bodies reared up and *none could withstand [their] attack.*²⁸⁹

121 [She set] up vipers, and dragons, and the (monster) [Lamamu],

122. [and hurricanes], *and raging hounds, and scorpion-men,*

123. *and mighty [tempests], and fish-men, and [rams];*

124. [They bore] cruel weapons, without fear of [the fight].²⁹⁰

“Now let us pause, and see what has been presented, and speculate on its possible meaning for the scenario of a “paleoancient” interplanetary war.

(2) The War as Interplanetary

“(a) The war is between the various “gods” as some go into rebellion, for reasons that the passages cited do not make immediately clear;

“(b) Tiamat appears to fashion two types of dreadful weaponry against her opponents:

”(1) *biological weapons*: there are certain features to be noted about these weapons if one follows the interpretive paradigm of the existence of sophisticated technology in extremely ancient times:

“(i) some are of apparently much-larger-than normal size and are reptilian in nature, strongly suggesting dinosaurs or similar creatures;

”(ii) some are apparently *hybrids between species*, suggesting the existence of a sophisticated genetics technology, e.g., “fish-men” and “scorpion-men”;

“(iii) This fact in turn suggests that the hybrid human-animal forms often used in Egyptian hieroglyphics to denote the gods might indicate that a reality once may have been the foundation of the association of such glyphs with the gods in ancient Egypt and other ancient cultures.²⁹¹

“(b) Weather weapons: hurricanes and immense storms. This implies the existence of a physics to engineer phenomena on a *planetary scale* by controlling or manipulating the electrodynamic properties of planetary atmospheres.

“But what were the motivations for this titanic struggle and the development and actual *use* of such horrendous weapons? These are alluded to at the very end of the first tablet and again in the second tablet of the *Enuma Elish*:

137. *She gave to (Kingu) the Tablets of Destiny, on [his] breast she laid them, (saying):*

138. *“Thy command shalt not be without avail, and [the word of thy mouth shall be established]. ”*

139. *Now Kingu, (thus) exalted, having received [the power of Anu]...[292](#)*

“The reference to “the power of Anu” is significant, since “Anu” in the Babylonian theogony is the name of God. Thus, whatever the “Tablets of Destiny” were, they conveyed such tremendous power to their possessor that the power was regarded as being divine.

“If one now combines the insights of Alford and Sitchin, for whom such ancient texts and names of “gods” were metaphors of naturally occurring planetary collisions and catastrophes - a metaphor telling of the destruction of the fifth planet of the solar system by collision with another large celestial body - with Sir Laurence Gardner’s understanding of such texts as a “titular” usage of the proper names of the sovereigns of the planets or regions involved, then one is left with the picture of an *actual, though extremely ancient, war of interplanetary celestial, or “heavenly” scale, exactly as recounted in other ancient traditions.*

“But what was the reason for this war? According to the epic, it was Tiamat’s possession of these mysterious “Tablets of Destiny” and the extreme power they conveyed. This constituted the primary reason for the war against her and for her utter destruction at the hands of her opponents. And this brings us to Marduk, the chief of her opponents in the epic, and to his arsenal and to “The Sequence of Tiamat’s Destruction.”

(3) The Sequence of Tiamat’s Destruction by Marduk in the Enuma Elish

(a) Marduk ’s Appointment as Sovereign

“The epic quickly moves to the topic of the appointment of Marduk as the leader of the coalition to defeat Tiamat:

13. O Marduk, thou art our avenger!
14. We give thee sovereignty over the whole world.
15. Sit thou down in might, be exalted in thy command. [293](#)

“Marduk a little further on is then given a very interesting mission:

31. Go, and cut off the life of Tiamat,
32. and let the wind carry her blood into secret places. [294](#)

“The significance of this mission will be lost unless one bears in mind the titular *pars pro toto* paradigm. On that view, Marduk is charged to destroy the entire planet represented by the titular term “Tiamat.” The horrendous biological and weather weapons Tiamat has unleashed on her opponents has called forth an escalation of the war as her opponents now call for her complete destruction. This is hinted at by the phrase that her blood - the life of the planet - is to be carried “into secret places.”

(b) Marduk’s Weaponry: The “Stealth Suit” and Invisible Weapon

“In this same context, Marduk is then given two rather interesting weapons, from this “paleophysical” point of view, one of which, perhaps, represents some form of stealth technology:

23. “Command now and let the garment vanish,
24. and speak the word again and let the garment reappear!”
25. Then he spake with his mouth, and the garment vanished;
26. Again he commanded it, and the garment reappeared. [295](#)

“In addition to this “stealth suit,” Marduk is given an invincible weapon, a weapon far exceeding Tiamat’s biological and weather arsenal:

27. When the gods, his fathers, beheld (the fulfillment of) his word,
28. they rejoiced, and they did homage (unto him, saying) “Marduk is King!”
29. They bestowed upon him the sceptre, and the throne, and the ring,
30. *They give him an invincible weapon, which overwbelmeth the foe.* [296](#)

“What this invincible weapon may be is not described nor named, but its effects appear to be in view in the following passage:

39. *He set the lightning in front of him,*
40. *with burning flame he filled his body,*

41. *he made a net to enclose the inward parts of Tiamat,*
42. *the four winds he stationed so that nothing of her might escape,-...*
43. The South wind and the North wind and the East wind and the West wind
44. *He brought near to the net, the gift of his father Anu.*
45. *he created the evil wind, and the tempest, and the hurricane,*
46. *and the fourfold wind, and the sevenfold wind, and the whirlwind, and the wind which hath
no equal.*²⁹⁷

“This passage implies a rather remarkable set of characteristics of the “invincible weapon”:

“(a) Its use apparently involved lightning, i.e., extremes of electrostatic energy;

“(b) The “net ” used to “enclose the *inward* parts of Tiamat” recalls the language of another Babylonian epic, the *Lugal-e*, which forms so much of the material Zechariah Sitchin used to reconstruct his “Second Pyramid War.”²⁹⁸ As was detailed in my first book, *The Giza Death Star*, the term “net” in the *Lugal-e* occurred in a context such as to suggest a weapon employing *gravity and acoustics* as its primary component. Thus, the “inward parts of Tiamat” strongly suggests an interpretation, *not of planetary “external” collisions, but something “internal,” affecting the planetary core of Tiamat.* Thus, Marduk’s “invincible weapon” appears to be able to tap into the field of space-time, i.e., the medium itself, and thereby the planetary *center* of Tiamat. While this interpretation is at this juncture highly speculative, it is corroborated in quite strong language at the end of the fourth tablet as we shall see.

“(c) If one understands the “net” in this fashion, as the gridwork or lattice or cellular-like structure of the medium itself, then further corroboration of this reading would appear to be provided by the reference to the “four winds,” which might be taken to mean the compass points, or even more abstractly, *coordinate references*. In this regard, it will be recalled that the ancient Hindu epics, examined in *The Giza Death Star*,²⁹⁹ made similar reference to a weapon that was tied to the four points of the compass.

“(1) Alternatively, such references to the “four winds” or “the four compass points” or, as is very common, the “four corners of the earth” might also be taken as indicating something even more profound. It will be recalled from *The Giza Death Star Deployed* that the simplest geometric solid that can be circumscribed in a sphere is a tetrahedron, a four-sided pyramid with four vertices touching the surface of a sphere.

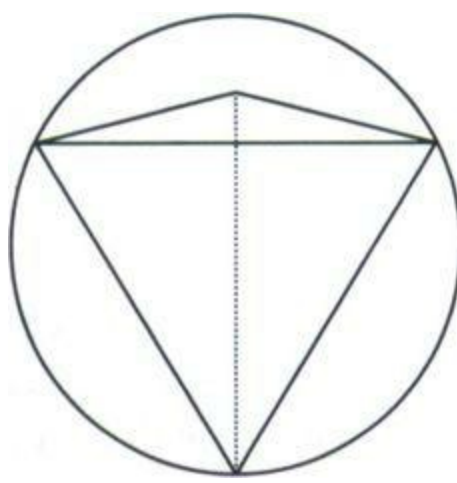

“(d) Finally, the passage refers to weather weapons that are specifically rotational or vorticular in nature: “hurricanes” and “whirlwinds”. In the context of the reading I am advancing here, these might be metaphors for structures involving longitudinal pressure waves in the medium. If this is true, then this is a very significant clue as to the fundamental unifying concept of paleophysics. It is, perhaps, the single most important clue, for it points clearly to vortex physics.

“With these thoughts in mind, we turn to the Sequence of Tiamat’s Destruction itself. This “Sequence” comprises the *main theme* of the Fourth Tablet of the *Enuma Elish*. In it, as we shall see, the signature of Marduk’s “invincible weapon” points very strongly to it being the type of “scalar” weapon employing such distortions or pressure waves in the medium as its primary component, exactly what I have argued in *The Giza Death Star* and *The Giza Death Star Deployed*:

47. *He sent forth the winds which he had created, the seven of them;*

48. *to disturb the inward parts of Tiamat, they followed after him.*

49. *Then the Lord raised the thunderbolt, his mighty weapon,*

50. *He mounted the chariot, the storm unequalled for terror,*

51. *He harnessed and yoked it unto four horses,*

52. *Destructive, ferocious, overwhelming, and swift of pace...* [300](#)

58. *With overwhelming brightness his head was crowned...*

...

65. *And the Lord drew nigh, he gazed upon the inward parts of Tiamat...* [301](#)

75. *Then the Lord [raised] the thunderbolt, his mighty weapon...*

76. *[and against] Tiamat, who was raging, thus he sent (the word):*

77. *”[Thou art become great, thou hast exalted thyself on high,*

...

78. *and thy [heart hath prompted] thee to call to battle....* [302](#)

87. *When Tiamat heard these words,*
88. *She was like one possessed, she lost her reason.*
89. *Tiamat uttered wild piercing cries,*
90. *she trembled and shook to her very foundations....*

...

95. *The Lord spread out his net and caught her,*
96. *and the evil wind that was behind him he let lose in her face.*
97. *As Tiamat opened her mouth to its full extent,*
98. *He drove in the evil wind, while as yet she had not shut her lips.*
99. *The terrible winds filled her body,...*

...

101. *He seized the spear and burst her body,*
102. *he severed her inward parts, he pierced (her) heart.*[303](#)

“Afterwards, Marduk then captures Tiamat’s allies,[304](#) recapturing the Tablets of Destiny from Kingu, and then returns to Tiamat to complete her destruction:

129. *And the Lord stood upon Tiamat’s hinder parts,*
130. *and with his merciless club he smashed her skull.*[305](#)
137. *He split her up like a fish into two halves;...*

...

143. *And the Lord measured the structure of the Deep.*[306](#)

“I believe these passages reveal a remarkably accurate sequence of what the destruction of a planet by a “scalar” weapon employing a longitudinal pulse or acoustic stress the medium itself would entail, right down to acoustic cavitation and large electrostatic displays, signatures of the use of such a weapon at extreme power. Let us note the sequence:

“(a) The “winds” are sent to “disturb” or destabilize the “inward parts” of Tiamat, the planetary core(w. 47-48);

“(b) “Lightning” is then unleashed on the already unstabilized planet from the “four winds”, i.e., from every direction(w. 49-50), or alternatively, at the tetrahedral “vertices”;

“(c) These “thunderbolts” are then apparently directed toward that destabilized core, suggesting that a sudden and extreme *pulse* is administered(vv. 58, 65, 75-78);

“(d) Tiamat responds with cries and trembles and shakes to “her very foundations”, i.e., experiences very severe earthquakes or acoustic cavitations throughout the planet, to its very

core(w. 95, 97-97);

“(e) Tiamat appears unable to break resonance with the weapon (w. 97-98) as Marduk spreads the net and drives in the final “wind” or pulse(v. 98);

“(f) Tiamat reaches maximum instability in her planetary core and mantle (w. 98-99);

“(g) Marduk pierces the crust, and releases the enormous energies that have built up in the planet through the acoustic cavitations, resulting in a colossal explosion with the entire planet as its fuel, rather like bursting a balloon filled to extreme pressure.(w. 101-102, 137).

“All this implies the existence of a physics sophisticated enough to “measure the structure of the deep”(v. 143), and to weaponize it.³⁰⁷ This last statement is the reason why it was argued that the reference to “winds” in the case of Marduk’s weapon may indicate the types of longitudinal pressure-waves associated with Tesla-like scalar weapons.

“Another comment is perhaps warranted by this discussion. It is to be noted that Marduk “measures the structure of the Deep” *after* Tiamat’s destruction. This would have been necessary in terms of the type of physics being suggested, since the destruction of a planetary sized body in the approximate orbit of the asteroid belt would have required an adjustment to astronomical measurements of the solar system, since its previously existing celestial mechanics and geometry has been shattered.³⁰⁸ With the explosion of a planet giving rise to the cyclic return of comets and the “catastrophes” they bring, one has an explanation for catastrophism itself. *The war and catastrophism are therefore intimately related, for on this view, the planetary wars of the “gods” is not a metaphor for the latter, but its very real origin and cause.*

“A final comment is necessary about the *Enuma Elish*. The preceding excerpts would seem to contraindicate its being a creation account at all. Rather, it would seem that it is more an epic of “War Among the Gods”.³⁰⁹ That it came to be interpreted as a creation epic involving dualism and dialectics of opposites is perhaps due to the quick change from creation in the opening verses to its preoccupation with war for much of the remaining epic. In this sense, it is an interpretation that the legacy civilization - Sumer and Babylon - most likely placed upon it.³¹⁰ But read from the paleophysics standpoint of interpretation being argued here and in my two previous books *The Giza Death Star and Giza Death Star Deployed*, it is first and foremost the account of a very ancient, very real, and quite interplanetary war within our own solar system, in a galaxy long, long, ago, and far, far away.”³¹¹

Marduk’s remarks in the *Erra and Ishum* are wholly in line with the outlines of the scalar physics found in the *Enuma Elish* cited above, referring, for example, to making the very heavens tremble, changing the positions of the stars, i.e., the planets of the solar system, even undoing the control of heaven and earth, a clear allusion to the broken celestial mechanics of the solar system after the explosion of Tiamat-Krypton (Krypton being another name for Tiamat, I believe).

And we can fix a date to this event, on the basis of Van Flandern’s revised Multiple Exploded Planet Hypothesis: 65,000,000 years ago. Marduk’s warning to Nergal in the *Erra and Ishum* is therefore perhaps obliquely referring to Van Flandern’s second event at 3,200,000 years ago, for it

would seem to be suggested by the *Erra and Ishum* that Nergal is plotting a similar destruction. As we shall see later on in this chapter, there is other textual corroboration from Mesopotamia of Van Flandern's two explosions at these two separate dates.

Returning to the *Erra and Ishum*, Marduk reveals to Nergal that he actually considered wiping out the survivors of his destruction of Tiamat and the resulting floods it caused elsewhere:

(As for) the people who were left from the Flood and saw the result of my action,
Should I raise my weapons and destroy the remnant?³¹²

This is an important statement, for it implies once again that there were *observers* of the destruction of Tiamat, of the awesome weapons deployed, and of the celestial displays that resulted. Shades of Anthony Peratt!

Then follows an astonishing challenge from Marduk:

I changed the location of the *mesu*-tree (and of) the *elmesu*-stone, and did not reveal it to anyone.
Now, concerning that deed which you have said you will do, Warrior Erra,
Where is the *mesu*-wood, the flesh of the gods, the proper insignia of the King of the World...?

....

Where is the pure *zaginduru*-stone which []threw away?³¹³

In the next chapter we shall examine the technological motivation for the war, the theft by Anzu of the Tablet of Destinies from Enlil. These, as we shall see there, are objects of technology that conveyed supreme power to their possessors. Here, Marduk appears to be referring to some similar objects, without which he hints that Nergal's plan is doomed to failure.

Nergal then addresses Marduk at length, and though the text is decayed at this point, perhaps one may speculate that he is challenging him to produce the locations of various stones and objects of power,³¹⁴ or perhaps, failing to learn their location, proceeds to persuade Marduk to join him in his course of action. This, it would seem from what follows, is a likely conjecture:

When Marduk heard this,
He made his voice heard and spoke to warrior Erra,

“I shall rise up from my dwelling, and the control of heaven and earth will be undone.
The waters will rise and go over the land,
Bright day will turn into darkness.
A storm will rise up and cover the stars of heaven.
An evil wind will blow, and the vision of people and living things will [be obscured (?)].³¹⁵

Marduk, in other words, appears ready to join Nergal's war and to inflict a second cosmic

catastrophe. If this would seem to be stretching the text, it is placed beyond doubt by Nergal's speech which immediately follows, and Marduk's reaction to it:

When Erra heard this,
He made his voice heard and spoke to prince Marduk,
 “Prince Marduk, until you re-enter that house...
 Until then shall I rule and keep firm control of heaven and earth.
 I shall go up into heaven, and give orders to the Igigi;
 I shall go down to the Absu and direct the Anunnaki
 ...
 I shall set my fierce weapons over them.
 At that house which you shall enter, prince Marduk,
 I shall make Anu and Ellil like down like bulls, to right and left of your gate.”

Prince Marduk listened to him,
And the speech that Erra made was pleasing to him.^{[316](#)}

Later on, after his success, Nergal is praised by Ishum in terms that imply his control over the very same scalar technology that Marduk used to destroy Tiamat:

Ishum made his voice heard and spoke to warrior Erra,
 ‘Warrior Erra, you hold the nose-rope of heaven,
 You control the whole earth, and you rule the land.’^{[317](#)}

Then follows a rather curious statement, one highly significant given what has already been said about the *Nephilim* and the use of hybrid species as workers and weapons; Ishum is speaking to Nergal:

“You have changed your divine nature and become like a human!”^{[318](#)}

This vaguely suggests that Nergal was also intimately involved in the hybrid creation projects.

No examination of the *Erra and Ishum* legend would be complete, however, without citing the lengthy speeches where Ishum describes Nergal's genocidal and monomaniacal character:

“You set up the weapons of *kidinnu*-men as an abomination to Anu and Dagan.
You have made their blood flow like water in the drains of public squares.”^{[319](#)}

O warrior Erra, you have put the just to death,
You have put the unjust to death.
You have put to death the man who sinned against you,
You have put to death the man who did not sin against you.

...

You have put old men to death on the porch,
You have put young girls to death in their bedrooms.
Yet you will not rest at all.³²⁰

Warrior Erra listened to him,

And the words that Ishum spoke to him were as pleasing as the best oil.

And Warrior Erra spoke thus,

“Sea (people) shall not spare sea (people), nor Subarian (spare) Subarian, nor Assyrian
Assyrian,
Nor shall Elamite spare Elamite, nor Kassite Kassite,
Nor Sutean spare Sutean, nor Gutian Gutian

...

Nor shall tribe spare tribe, nor man man, nor brother brother brother, and they shall slay
one another.”³²¹

What emerges from this legend is the picture of a supreme warlord, basking in his sick bloodlust and supreme powers of destruction, affording yet another glance in the ongoing struggle in the pantheon for supreme power.

3. Preliminary Conclusions

These Mesopotamian excursions allow certain tentative conclusions to be drawn.

1. First, there are allusions to two separate sets of catastrophes, particularly in the *Erra and Ishum* with Marduk's sudden entry, a primeval or very ancient one involving a Deluge and Marduk, and a more recent one, also involving a Deluge, contemplated and presumably executed by Nergal;
2. Nergal appears to wield the same scalar technologies once wielded by Marduk;
3. The warfare in the pantheon is revealed to be ongoing, though perhaps of intermittent periods, not only over several millennia, but even over several millions of years;
4. It is clear from the Mesopotamian texts that there are two versions of mankind, a hominid version which exists *prior* to the "gods'" manipulations and engineering of a second version, which is a chimeric hybrid, part "god" and part "clay";
5. It is clear that mankind is one motivation - in his overpopulation in the Mesopotamian tradition - of the conflict. Similarly, it appears that mankind's fear of the gods, particularly in the case of Nergal, is one of the sought-after goals of the gods. It is as if they feed off man's strongest emotions, in this case, the fear of death and destruction. As noted in the detailed examination of these myths above, mankind appears to be both some kind of goal or prize of the war, as well as a battlefield over which it is in part fought.

These outlines can be perceived in the other great ancient tradition from the Middle East, Egypt, and in some cases, significant new details can also be discerned.

B. The Egyptian Version

Corroboration of the Mesopotamian legends comes from one of the most obscure texts of ancient Egypt, the so-called Edfu temple texts. So obscure is this text that it has never been completely translated, and perhaps for good reason, for its contents would certainly be of extreme interest to anyone wishing to reconstruct not only a “paleoscience” but also the events of that paleoancient pantheonic war. So obscure are the Edfu texts that the best source for their study remains a secondary source which quotes extensively from them. This is E.A.E. Reymond’s *The Mythical Origin of the Egyptian Temple*, published by the University of Manchester in England in 1969. Another important source is revisionist author Andrew Collins’s *Gods of Eden: Egypt’s Lost Legacy and the Genesis of Civilisation*. The latter book is relied on here primarily due to the relative ease with which it is publicly available, although Reymond’s work will also be extensively cited for certain details.

The Edfu texts are found inscribed on the walls of the temple of Edfu. Collins notes that what remains of this temple was “begun in 237 BC, and yet it was not completed until 57 BC.”³²² Since each temple had its own “building text” that summarized “the name, nature, ritual significance and sometimes even the contents of decoration of the particular room,”³²³ then it is “possible to draw up an outline picture of the nature and significance of temple as a whole” by conflating these texts.³²⁴ Like many other Egyptian texts, however, the Edfu texts clearly stated that they were based on extremely ancient antecedents, for “according to legends carved” on the stone walls of the temple, the current structure was a replacement for a much older temple

designed in accordance with a divine plan that “dropped down from heaven to earth near the city of Memphis. Its grand architects were, significantly, Imhotep - a native of Memphis and, of course, a high priest of Heliopolis - and his father Kanefer.”³²⁵

The Edfu texts, in other words, claimed a very ancient provenance.

But the “jewel in Edfu’s crown” are its “so-called Building texts which adorn whole walls in various sections of the existing Ptolemaic temple.”³²⁶ It is here that E.A.E. Reymond’s work enters the picture, for as Andrew Collins observes, “she was one of the few people who seemed to have grasped the profound nature of the Edfu texts and realized that they contained accounts of a strange world that existed in Egypt *during what might be described as the primeval age.*”³²⁷ While “the texts at Edfu are many and varied,” Collins observes that it is almost a certainty

that much of their contents was derived from several now lost works, with titles such as the *Specification of the Mounds of the Early Primeval Age*, accredited to the god Thoth, the *Sacred Book of the Early Primeval Age of the Gods* and one called *Offering the Lotus*. All of these extremely ancient works begin with the gradual emergence out of the Nun, the primeval waters, of a sacred island, synonymous with the primeval mound of Heliopolitan tradition. This event is said to have occurred during a time-frame spoken of by Reymond as the “first occasion” - her interpretation of the Egyptian expression *sep tepi*, or the First Time.³²⁸

As I noted in the first book of my *Giza Death Star Trilogy*, *The Giza Death Star*, physicist Paul LaViolette understands this primeval mound to refer to the a paleoancient and highly developed science of a transmutative aether or medium of creation. The “mound” being the first emergence from that sea of nothingness, the Nun or primeval waters, of a particle wave form.³²⁹

Around this primeval mound, which was known as “the Island of the Egg” was a “channel of water,” and on the edge of it was “a field of reeds” that constituted a kind of sacred domain where columns “referred to as *djed*-pillars” were erected for the domain’s “first divine inhabitants.”³³⁰ These were led by a group of “Sages” who were in turn led by “an enigmatic figure called... simply This One.”³³¹ These Sages of “faceless forms were said to have been the seed of their own creation at the time when the rest of the world had not yet come into being.”³³² Indeed, these Sages are said by the Edfu texts to have preceded the appearance of the standard Egyptian gods.³³³

This tranquil state of affairs does not continue for long, however, for

The Edfu account ... *alludes to some kind of violent conflict which brought to a close the first period of creation. An enemy appears in the form of a serpent known as the Great Leaping One. It opposes the sacred domain’s divine inhabitants, who fight back with a weapon known only as the Sound Eye, which emerges from the island and creates further destruction on behalf of its protectors.* No explanation of this curious symbol is given, although Reymond felt it to be the centre of the light that illumines the island. *As a consequence of this mass devastation, the first inhabitants all die...* Death and decay are everywhere - a fact recorded in the alternative names now given to the Island of the Egg, which include the Island of Combat, the Island of Trampling, and, finally, the Island of Peace.³³⁴

These statements positively compel and require commentary.

Firstly, it is to be noted that sometime after their “self-creation” from the “primeval waters,” an expression of speech that I believe refers to La Violette’s underlying transmutative medium, a cosmic and cosmically violent conflict, a war, erupts. Moreover, the similarity here to Tiamat, whose name likewise symbolizes not only a planet, but primeval waters in the Babylonian *Enuma Elish*, is not to be overlooked. In other words, the Edfu text may be obliquely referring to the destruction of Tiamat-Krypton, Van Flandern’s first exploded planetary event, that took place ca. 65,000,000 years ago. But there is another possible parallel to be noted, and this is the similarity of the Edfu account of a primordial war or conflict that occurs almost immediately after the founding of the “island” or first creation, to that of the Fall of Lucifer in the Judeo-Christian tradition. More will be said on this subject in a later chapter, but it is important to draw attention to it here.

Secondly, the individual that appears to have wrought this destruction is referred to as “the Great Leaping One,” a title we have encountered before as a Vedic reference. This title seems to beg for association with the priests of Sali in ancient Rome, who celebrated the feasts associated with Mars and the founding of Rome by leaping in the streets and blowing trumpets.³³⁵ In other words, the Edfu texts are obliquely indicating that this ancient war, the end of the period of the “First Creation,” somehow involved *Mars*. There are numerous connections to Mars to be considered, and it is best to do so now.

1. Edfu and the Mars Connections

As mentioned above, when the primeval “island” or “mound” emerged, it “seems to have been in darkness, surrounded by the primeval water.”³³⁶ Before continuing, a connection to the Babylonian epic, the *Enuma Elish* should be noted, for the destruction of the planet Tiamat by Marduk may also be interpreted as the destruction of the primeval waters, since the name “Tiamat” signifies precisely those waters. Thus, the Edfu accounts, by referring to a similar primordial conflict that results in the destruction of the first “mound” is describing a similar, if not the very same, event. But in any case, once this primordial mound is brought forth, the Edfu texts relate that it was attended upon by two deities, named Wa and Aa.³³⁷ And here another connection to Mesopotamia may be in evidence, for as is well known, another name for the Sumerian god Enki is Ea, who is of course Enlil’s opposite number. This suggests that perhaps the god Wa is but the Edfu texts’ name for Enlil.

It is in this primordial conflict that we encounter numerous threads of connection to Mars. For example, Reymond points out that the Edfu texts also are a catalogue of the “origin of the sacred places of the Falcon and those of the Sun-God.”³³⁸ The mention of the Falcon recalls one name for Horus in the Egyptian symbolism of the gods, and that is his title “Falcon of the Horizon.” This title is a connection to Mars as will eventually be seen. The sun-god referred to here is, of course, Ra. Thus in the Edfu texts, there is implied a clear set of relationships between Edfu, Horus and thereby Mars and Ra.

A further connection to Mars is to be observed in a title given in the Edfu texts to the “island” *after* the conflict, and that is “the underworld of the soul.” In this respect, one should recall that the connection between Mars and the underworld is very clear in the Mesopotamian tradition, with Nergal, the god of Mars who is also the god of the underworld. As Reymond also observes, it is shortly after this initial primordial conflict that the appearance of the “serpent” first occurs.³³⁹ This fight against the snake was led by none other than the Falcon.³⁴⁰ However, the Edfu texts give Horus himself his own peculiar association with serpents. According to Reymond, Horus “is equated with Tanen, and is described as the ‘snake who created the Primeval Ones...’”³⁴¹ But what of the first serpent, against whom this struggle is waged? Reymond observes that this serpent has a most unusual, and for our purposes here, significant title; he is known as “The Great Leaping One.”³⁴² This is a very strong connection to Mars, for as I noted in my book *The Giza Death Star Destroyed*, the ancient Roman festival for Mars, whose priests were known as the “leaping priests,” because of their practice of jumping and leaping during the Mars festival.³⁴³ In the Vedic tradition the title of “The Leaping One” is precisely a designation for Mars.

Consequently, the Edfu texts convey, in the following variety of ways, a connection between the primordial “war,” the “island,” and Mars:

1. In the connection between Horus, the “Falcon of the Horizon”, and Mars;
2. In the title “the Great Leaping One” and its connection to Mars;
3. In the fact that the “island” is surrounded by primordial waters, which closely parallels the designation of Tiamat in the Mesopotamian tradition, in this case, Tiamat’s *orbit* would

“surround” the “island” of Mars.

But it is even more illuminating to note what the Edfu texts have to say about the weapons used in this ancient conflict. The inhabitants of the sacred “Island of the Egg” fight back with a weapon called the “Sound Eye,” a weapon which the Edfu texts state emerges *from the island in the very same waters, i.e., from the very same transmutative medium*. This strongly suggests that the “sound” involved was longitudinal pressure waves or stresses in the medium itself. In short, the “Sound Eye” may be a crude metaphor for these very type of “electro-acoustic” longitudinal waves and stresses in the medium, the “Sound” part of the “Sound Eye” referring to the “acoustic” part of “electro-acoustic,” and the “Eye” part referring to the “electromagnetic” part. “Sound Eye” is thus a crude, but synonymous way of saying “electro-acoustic.” Thus, while Collins observes that Reymond provides no explanation for this curious weapon,³⁴⁴ an explanation is readily available if one interprets it as a metaphor for the type of scalar “paleophysics” I advanced in my three *Giza Death Star* books. This “sound eye” parallels traditions noted in Ovid of a race of giants called Telchines who blighted the land by a glance from an “evil eye.”³⁴⁵ A clue to the power of this weapon may be seen by comparing it to another part of the Edfu texts dealing with the creation itself.

Reymond notes that the act of creation is a “symbolic and magical rite” whose main part

Consisted of uttering sacred spells by the creators over certain (objects) which, we may say, might have been believed to symbolize the Earth to be created. We suspect that by virtue of this rite it was believed that the symbols of the Earth were filled with special power.

Thus far, these objects and the associated “spells” sound very much like the Sumerian Tablets of Destinies, a similarity that will assume great importance in chapter ten.

This process of creation of the Earth by the word of the creators has no equivalent. Such a manner of creation can be compared with the Hermopolitan conception of the creation of the world; according to the latter, the Earth was believed to have been created by drying up the primeval waters that surrounded the island. Both of these ways of creating, the magical process as well as the procedure by solar radiance, had the same result, they seem to have made manifest what was created previously by the nameless powers, but was hidden beneath the primeval waters.³⁴⁶

Note what Reymond has really implied here:

1. The Edfu accounts, by maintaining a creation by the utterance of “magic spells” is paralleling yet another famous account of a similar concept of creation, that of Genesis 1. Both maintain that *sound* is somehow involved;
2. These “spells” were, however, unlike the Genesis account, uttered *over* certain objects which then created the various “earths” desired;
3. If one adds in the Hermopolitan tradition, the use of (solar) radiation or energy is also a component.

Boiling this down, we have:

1. Sound
2. Objects
3. Energy, or radiation.

If this begins to sound eerily similar to the scalar physics discussed in chapter two, it should, for a scalar wave is nothing less than a pressure wave or stress in the medium of space time itself, a stress in turn caused by the interferometry of electromagnetic radiation. Viewed in the paleophysical sense, then, the Edfu texts are describing *a process of creation by the paradigms scalar physics*, a process that possesses “all the power of the universe.”

Note then Andrew Collins’ extremely intriguing comment that the use of this “Sound Eye” by the Island of the Egg’s inhabitants to defend themselves results in their utter destruction. This too may be seen in the light of the Exploded Planet Event at 65,000,000 years ago, for the explosion of such a large planet, especially if it was water-bearing, would have likely nearly obliterated any life on Earth. The “smaller” event of some 3.2 million years ago, while causing severe collateral damage in its immediate celestial vicinity, would not have been as drastic.

But with this observation, one must raise an objection: there is nothing in the Edfu texts thus far to suggest that this primeval “Island of the Egg” was on Earth at all. Moreover, my own suggestion that it is a metaphor for the paleophysics of a transmutative aether and the emergence of particles from the “sea of quantum fluctuations” would also seem to preclude this idea. We shall return to this point in a moment.

Collins remarks that “after this violent conflict with the enemy serpent, a major transition occurs in the conception of the sacred island. For a time it vanishes beneath the primeval waters of Nun...then it emerges again and henceforth is given the title Underworld of the Soul. It also becomes known as the Place of the First Occasion...”³⁴⁷

The history of this sacred Island is as equally interesting after the war as before it. The Edfu texts state that a second and new group of divine inhabitants comes to dwell on the Island, whose leaders are Wa and Aa,³⁴⁸ the latter of which may be identical to the Mesopotamian Ea. The leaders of this new group of occupants are given “enigmatic titles such as ‘The Far Distant’, ‘The Sailor’” and a title suggestive of their bloodthirsty and/or cannibalistic nature, “The Lord, mighty-chested, who made slaughter, the Soul who lives on blood.”³⁴⁹

Note the sequence that we now have:

1. Sages “create themselves” from the “primeval waters,” a metaphor, perhaps, for a paleophysics of a transmutative aether or medium. These sages then occupy an “island” in the midst of water.
2. A “Great Leaping One,” a serpent, goes to war with the divine inhabitants of the Island, who defend themselves with the “Sound Eye” and destroy themselves in the process.
3. The Island recedes back into the primeval waters, and again reemerges with new occupants, who appear to be of a different, warlike and bloodthirsty character, than its first inhabitants.

These observations suggest that ownership or dominion of the island changed hands, a point whose full significance will be appreciated in a moment.

Then,

After an undisclosed period, rising waters again threaten the Island of Trampling, causing the original temple ... to be damaged or destroyed. Yet then something curious occurs.... *Wa and Aa are instructed by the God-of-the-Temple to enter within the enigmatically named Place-in-which-the-things-of-the-earth-were-filled-with-power, another name for the water-encircled island, and here they conduct “magic spells” which make the waters recede. To this end they appear to have used mysterious power objects, named iht, “relics”, which are stored within the island.*³⁵⁰

Once again, the text is capable of a deeper understanding.

To see how, one must unpack the italicized statements one by one.

Firstly, the gods Wa and Aa are instructed to enter “the enigmatically named Place-in-which-the-things-of-the-earth-were-filled-with-power,” that is, they are required to enter some sort of structure, to be in or in proximity to it, in order to accomplish whatever it was they were doing. This important point raises yet another component of the scalar physics that I believe was a crucial element of the ancient technology, and that is *consciousness*.³⁵¹

Secondly, note that the “Place-in-which-the-things-of-the-earth-were-filled-with-power” is another name for the island itself, i.e., it is now a physical location that can be “entered.”

Thirdly, they enter it in order to make use of “mysterious power objects” that are themselves stored inside the island.

This is beginning to sound an awfully lot like the mysterious “power stones” of Mesopotamian tradition that will be examined in the next chapter, and an awfully lot like Ninurta’s entry into the Great Pyramid to inventory its contents, an event described in detail by Zechariah Sitchin in his *Wars of Gods and Men*.³⁵²

But once again, we are far from making the case that the “sacred island” is to be identified with Giza or its pyramids. That case will be made in a moment.

Collins then makes some crucial observations about the history of *constructions* on the sacred island. According to Collins, “various subsequent stages in the creation of the world involve a gradual progression” in the construction of a “Temple of the Falcon, while a further building, named as the Solar Temple, *is said to have been built on the site of an earlier battle, plausibly one connected with the destruction of the first divine inhabitants by the enemy serpent.*”³⁵³ Alan Alford, it should be recalled, argued persuasively in his book *The Phoenix Solution* that the (1) Great Pyramid, (2) the Second Pyramid, the Sphinx and Temples, and (3) the other structures at Giza represented three distinct phases over a prolonged period of time in the construction of the Giza complex, with the Great Pyramid representing the oldest, pre-Egyptian phase, the Second Pyramid Sphinx, and temples representing a later, though still pre-Egyptian, phase, and the remaining

structures the distinctively Egyptian phase of construction.³⁵⁴ It is thus possible that the Edfu texts are referring to the same phased construction phenomenon, though it should be observed that its first phase would be far more ancient than what Alford proposes.³⁵⁵ Collins concludes his remarks by stating that prior to beginning each new phase, various consecration rites were performed using the very same power objects as once resided in the island.³⁵⁶ E.A.E. Reymond seems to concur with at least the general tenor of these speculations, for she herself remarks “We incline to the opinion that experiences of a far distant past lie at the heart of the Edfu myth of creation.”³⁵⁷ Collins himself concurs: “The incredible significance of the Edfu material cannot be overstated, for the Egyptian priests, scribes and artists involved in preserving these traditions saw them as very real events that preceded the rise of their own civilization.”³⁵⁸

2. *The Strange Story of the "Rostau"*

It is Collins himself, however, who makes the identification of the "sacred island" of the Edfu texts with the Giza compound.

The key to this identification is to be found in the sacred island's title "Underworld of the Soul," a title given to it after the primeval conflict between the serpent, the "Great Leaping One," and its original inhabitants: "The term 'underworld' is the same here as that used in the Heliopolitan texts to describe the journey of the sun-god through the *duat-undenvorld*... ³⁵⁹ It is this journey that Osiris first undertook. And with Osiris comes the link to Giza, for in the famous Inventory Stela, discovered at Giza in the nineteenth century, reference is made to various structures on the plateau "including the Great Pyramid and Great Sphinx." More importantly, it records "the visit to Giza of King Khufu." This is highly significant for it would appear that the ancient Egyptians were not in synch with modern standard Egyptology, since Khufu reigned before Khafre, the latter being the King standard Egyptology believes to have built the Great Pyramid!³⁶⁰ In other words, the Great Pyramid was said by the ancient Egyptians themselves to be of greater antiquity than current standard theory allows.

But this is not all.

The Inventory Stela "also makes reference to the 'House of Osiris, Lord of Rostau'. Since the Sphinx is cited as being 'north-west' of this 'House of Osiris,' it is thought by some writers to be a reference to the Valley Temple, which lies roughly east-south-east of the Sphinx monument."³⁶¹ Collins himself draws the inescapable conclusion: "It therefore seems certain" that the "sacred island" and home of the "Sound Eye" and all its environs "-with its field of reeds, water-encircled island and temple complex - *was almost certainly located at Giza.*"³⁶²

Giza, in other words, was directly associated with the "true Point of First Creation,"³⁶³ referred to in the Edfu texts, as Collins puts it, it is an "attractive supposition." But if this is so, then it is also the true point of the "Sound Eye" and the locus and center of the terrible conflict with the "Great Leaping One" that brought an end to that first creation, and new, more bloodthirsty occupants of the "sacred island." It was, in short, the location of the weapon that brought a cataclysmic end to a conflict in the pantheon and ruin to the people that wielded it.

But Collins *does* mention another difficulty:

There is, however, one major problem - how might we reconcile the appearance of the plateau today with the description of (the sacred island) as a temple located beside a field of reeds, situated on the edge of a primeval lake containing a small mound-like island?³⁶⁴

Collins' answer is "that in the *eleventh millennium BC*, low-lying areas east of the Giza plateau were regularly, if not permanently, flooded to create a shallow lake that may have encircled a small rocky island."³⁶⁵ Consequently, the first two phases of construction at Giza at least - namely the Great Pyramid, the Second Pyramid, the Sphinx, and the Temples - would seem to be millennia older than dynastic Egypt. With this in mind, it should be observed that the very physical *form* of Giza,

“mountains” or “mounds” in the form of the pyramids emerging “from the waters,” sticking up over the surrounding lake, is *itself* a visible analogue to the *Sep Tepi*, to the First Time when the primeval mound emerged from the primeval waters, or medium. The whole compound is, in other words, suffused (or perhaps inundated would be a better word) with visible analogies of the scalar physics of the transmutative medium, even in the very form of the lake and mounds/pyramids themselves.

Recall, however, that the Edfu texts stated that the original mound *disappeared* back into the waters, only to reemerge as a new mound-island, with a new title or function. There seem to me to be two possible ways to understand these ideas in view of the identification of Giza with the original sacred island of the First Time, and that is (1) either the pyramids/mounds disappeared under massive flood waters and reappeared, or (2) the original structures present at the site were destroyed or partially destroyed in the conflict, and the current structures were built over the ancient sites as an attempt to rebuild and reconstitute the original island/mound of power. This may indicate that the current Great Pyramid (and the Second Pyramid) may be *copies, reconstructions, of something far older*, whose remains may yet lie buried far beneath it.

A further connection is highlighted by the term “Rostau.” Author Peter Goodgame, in an article entitled “The Myth and Religion of Osiris the God,” observes that “the word Rostau means *underground tunnels*” and as such “was simply another name for the Giza plateau and the many tunnels underneath it.”³⁶⁶ Goodgame notes that this understanding of the meaning of “Rostau” is “clarified by a stela (sic et passim) that once stood between the paws of the Sphinx that is attributed to Thutmose IV (c. 1400 BC). Line seven of this stela states that the Sphinx lies ‘beside the house of Sokar... in Rostau.’”³⁶⁷

These points allude to still other connections to Mars, for these underground tunnels constitute a kind of “underworld,” and the Sphinx, of course, has its own counterpart on the Martian surface with the famous “Face” at Cydonia.

3. The Mysterious “Sound Eye”

As I outlined above, the mysterious “Sound Eye” may be a metaphor for the type of electro-acoustic stresses in the medium that form a central component in scalar physics. Collins himself is alive to the possibility that something dangerous may lie far beneath the Giza complex, as the Edfu texts themselves imply: “What was the... divine power source spoken of in the Edfu texts? Was it still there beneath the limestone bedrock awaiting discovery, or had it been removed and destroyed long ago?”³⁶⁸ Collins leaves no doubts about the power attributed to it in the texts:

Illustrations of the House of Sokar show a fiery-orange bell-shaped *omphalos*.... This object is placed in direct relationship with both a sacred island... and the mound of creation, suggesting therefore that it was synonymous with the ‘embryo’, ‘seed’, ‘egg’, etc. of the Edfu and Theban creation myths, as well as with the Heliopolitan concept of the *benben-stone*.

*Were we therefore dealing with the presence at the heart of the underworld complex of some kind of enormous sacred stone associated with the potency of cosmic creation? Did it embody the coming together, the crystallization, of the universe’s creative power source?*³⁶⁹

On the basis of what I said earlier regarding the “Sound Eye” I believe the answer to this is probably yes.

But Collins adduces “one more tantalizing piece of evidence which hints at the presence of something of extreme magical potency beneath the bedrock at Giza-Rostau.”³⁷⁰ Spell 1080 of the Heliopolitan *Coffin Texts* states “This is the sealed thing, which is in darkness, with fire about it, which contains the efflux of Osiris, and it is put in Rostau. It has been hidden since it fell from him, and it is what came down from him onto the desert of sand.”³⁷¹ Collins then comments that spell 1080

Points clearly to the fact that this powerful object has been sealed away in total darkness. Yet despite its solitary confinement, Spell 1080 still tells us that it has ‘fire about it’, implying that it emits some form of divine fire or radiance, exactly what is stated in the Edfu texts in connection with the nucleus of the underworld complex. That ‘the sealed thing’ is said to have been ‘put in Rostau’, where it now lies hidden, seems doubly to confirm that we are dealing with an actual physical object inside an underground world that exists to this day beneath the sands of Giza.³⁷²

As will be seen in the next chapter, the “sealed thing” resembles quite strongly the “power crystals” and “Tablet of Destinies” that lay at the center of the Mesopotamian accounts of a war for their control. Indeed, as we shall also see, Ninurta, when he makes his inventory of “power stones,” reserved one stone - whose destructive power is enormous, and which cannot be destroyed - for secret preservation. It is my belief that all these things are one and the same identical object, a stone or crystal - a *technology* - that made the whole thing “work.”

Collins is also alive to the possibility that the “Sound Eye” may represent some lost science and technology of *sound*. Citing other traditions and anomalies dealing with sound, Collins mentions the

Incan and Andean tradition surrounding Viracocha who consumed “stones” by fire, thus enabling men to move large blocks by hand “as if they were cork.”³⁷³ This was aided by individuals who possessed “supernatural powers” that allowed large blocks to be levitated through the air “to the sound of a trumpet.”³⁷⁴ The Mayans had similar acoustic levitation myths,³⁷⁵ as did the Greeks,³⁷⁶ and there were even contemporary reports of similar phenomena being used by the lamas of Tibet to levitate large rocks.³⁷⁷ He even mentions the case of nineteenth century American inventor John Worrell Keely, whose weird acoustical inventions were observed by witnesses to be able to disintegrate the hardest rock with mere vibration after appropriate tuning of his devices by the inventor, and yet who, to his own frustration, discovered that somehow his own physical presence was required to make his inventions work!³⁷⁸

This last fact recalls in a rather curious fashion the statements of the Edfu texts that the physical presence of Wa and Aa was required in the sacred island in order to make its power work, an indicator again of effects associated with scalar physics, which explains such phenomena as the ability of people to subtly affect the structured potential of the local vacuum.

C. The Human Version: the Ullikummi Text

Some researchers might be inclined to dismiss E.A.E. Reymond's and Andrew Collins' interpretation of the Edfu temple texts on the grounds that - while the texts purport to refer to an extremely ancient conflict surrounding the "power of creation" that was embodied at Giza - the temples on which the texts are found are not that old.

But how would the Hurrian *Ullikummi* texts³⁷⁹ be explained? Undeniably ancient, these texts refer to a similar conflict, and often parallel the conceptions of the Edfu texts in a rather astounding way. The text centers on the Hero-God Ullikummi's birth from the mother-goddess, and his subsequent exploits. As will be seen as we proceed, the texts are certainly capable of a catastrophist interpretation. But they are equally capable of a "war" interpretation. The following passage is one example of this:

Kumarbi in his own mind began to speak:

"What name shall I put on him,

On the son whom the Fate-Goddesses and Mother-Goddesses gave me?

Out of (her) body like a spear point he sprang -
He shall go!

Ullikummi shall be his name!

He shall go up to the Celestial Realm to kingship!

And he shall press down the beloved town of Kummiya!

He shall hit the sky-God,

And he shall pound him (into) salt,

And he shall crush him like an ant with his foot,

He shall break off Tashmishu like a [...] reed!

He shall scatter all the Gods down from the Celestial Realm like birds,

And he shall break them like empty vessels!"

Note the reference to the "sky-god" which suggests a parallel with the Sumerian god Anu. There follows a passage reminiscent of Marduk's conflict with Tiamat:

And he shall pound him (into) salt,

And he shall crush him like an ant with his foot,

He shall break off Tashmishu like a [...] reed!

He shall scatter all the Gods down from the Celestial Realm like birds,

And he shall break them like empty vessels!"

Clearly this passage is capable of a catastrophist interpretation along the lines of Alford's colliding and exploding planets, since the "gods" referred to are in the "Celestial Realm." The "gods" or planets in this case are clearly shattered, "broken like empty vessels." But observe that it is equally capable of a war interpretation, a possibility that becomes stronger as we proceed.

The text soon begins to display its own evidences of an underlying "paleophysics" as well, for the god Kumarbi then asks:

"Who will carry him (Ullikummi) to the [dark] earth
(So that) the Sun-God of the Celestial Realm
And the Moon-God shall not see him?"

The references to the "Sun-God" and the "moon-God" are indicators, once again, that the characteristics and symbols of various ancient gods strongly parallel each other, the Sun-God resembling Egypt's Ra and Mesopotamia's Marduk, and the Moon-God resembling the Moon-associated gods Osiris and Thoth of Egypt and Nanner-Sin of Mesopotamia. But what of the reference to "the [dark] earth?" This might possibly refer to the void of space itself, a reading in keeping with the "paleophysical" interpretations both of Alan Alford and Paul La Violette.

But then follows a curious speech of the god Kumarbi:

And Kumarbi began to speak to the Irshirraas-Gods:
"Take [this child],³⁸⁰
And [treat] him as a gift,
And carry him to the dark earth
Hurry, hasten!
And put him as a spear point
Upon Upelluri's right shoulder!"

Upelluri is an Atlas-like god who carries the heavens and the earth on his shoulder. But what sort of "child" is this Ullikummi? What follows is a strange statement:

In one day he shall grow a "yard";
In one month he shall grow a "furlong";
The stone which is at his head,
His face shall cover."

This text lends itself to a catastrophist interpretation very handily, for the "growth" of the "child" can be, and is, understood by some to refer to the growth of a comet's visible tail as it approaches the Sun, and "the stone which is at his head" would thus be the core of the comet itself.

But there is another possibility, one which will loom larger as we proceed, and that is that the text is describing *construction*, in this case, construction of a pyramid. The "stone which is at his head, (which) his face shall cover" could equally be the stone which covers the face of a pyramid.

This interpretation of Ullikummi being some sort of "stone"child — whether that of a comet or a pyramid — is made obvious by what immediately follows, when Ullikummi is presented to the god

EnlilEllil, whom we have encountered before:

And Enlil lifted his eyes,
And he saw the child.
The child was standing before the Deity:
*The child's body was made of stone,
Of meteorite-stone.*

Here one has a little-noticed theme of some ancient texts, and that is the reference to stones as living things. But what is to be noticed here is the translation of “meteorite stone.”

In this instance, catastrophism has intervened to construe the translation in favor of the theory, for as H.G. Guterbrock and Harry A. Hoffner, foremost translators of Hurrian texts, maintain, the word is best translated as “basalt stone.” Basalt, as it turns out, is a stone not readily associated with meteors, but rather with *volcanoes*, which suggests a different version of catastrophism, one dealing not with the growth of comets' tails but with the growth of a volcano.

But basalt can have some very strange properties. David Hatcher Childress observed the massive basalt stones used in the construction of Nan Madol on Pohnpei Island in the western Pacific:

One of the travelers from the Village Hotel had a pocket compass with him and moved it along one of the basalt crystals on the wall of Nan Dowas. “Hey look at this!” he called. His name was Sid, and he was from Michigan. We all looked at his compass as he moved it along a horizontal block in the massive wall. The needle spun around and around.

A geologist who was part of the group looked at it and said, “It is normal for basalt to become magnetized like this as part of its cooling process, but it should be magnetized vertically. The needle should not spin like that. These stones are strangely magnetized.”[381](#)

Might these strange stones have been the product of a technology rather than a volcanic accident of nature? Basalt might have been superheated in a kind of spinning furnace, with the molten rock spun at very high speeds, and then suddenly cooled, polarizing the rock magnetically. But in any case the Ullikummi text is capable of more than one catastrophist interpretation.

Immediately after the stone “child's” presentation to Enlil, however, the latter makes a very curious, and very strange statement if one were only dealing with catastrophism, whether cometary or volcanic:

*“This is an evil plan
Of no one but Kumarbi!
(Just) as Kumarbi raised the Sky-God,
So he raised this (basalt-)stone as (a) rebel against him!”*

This is the first hint that the war is a war of rebellion, a civil war in the pantheon. And note the context in which it occurs: the “raising” of “basalt” stone against “the sky-god.”

The text continues:

When Enlil [ceased to speak] these words,
 They put the child as a spear point
 Upon Upelluri's right shoulder.
 He grew up, the (basalt-)stone,
 And the strong [...] raised him:
 In one day he grew one "yard",
 In one month he grew one "furlong";
 The stone which was at his head,
 His face covered.
 When the fifteenth day came,
 The Stone had grown high.
 And he stood in the sea on his knees (point)
 Like a spear-point.
The Stone, he stood out of the water,
And his height was like [...],
And the Stone reached from the sea like a garment
Up to the "Place of the Belt. "
The Stone, like a [...] he was lifted,
And he reached up to the temples and chamber in the celestial realm.

The "meteor catastrophe" reading of the text now seems to be definitely excluded, since the text clearly refers to Ullikummi, who is "the Stone," reaching up "from the sea like a garment," a reference which would clearly favor the volcanic catastrophist reading.

But there is a reference in the text that would seem to exclude that interpretation as well, and that is the line that immediately follows, for the "Stone" reached up from the sea to "the Place of the Belt." This would seem to be a reference to the constellation Orion, and to the three stars that comprise Orion's "belt." And here the text now begins to take on its peculiar parallel to the Edfu texts, and to their reference to the "Rostau," for nowhere does one find "stones" reaching up to heaven in connection to Orion's belt other than at Giza, whose three main pyramids are arranged in the exact geometric analogue of the constellation!

Consequently, both catastrophist readings of the text — as referring to a comet or to a volcano — would seem to be contraindicated by this statement. The text is referring to a real earthly site, and to its *construction and use in the cause of that conflict and rebellion*. The emergence of "The Stone" from the sea clearly recalls the parallel themes — including those of conflict — found in the Edfu texts.

The Ullikummi text then continues with statements reminiscent of yet another epic, the Babylonian *Enuma Elish*, of a power capable of altering the very celestial mechanics of local space:

And the Sun-God began to speak in his own mind:
 "What swift God [is standing] in the sea?
 His body is not like that of the [...] Gods."
 The Sun-God of the Celestial Realm turned [his face],
 And he went out into the sea.

And the Sun-God held (his) hand to his forehead.

[...]

and from his anger

his [...] became altered.

When the Sun-God of the Celestial Realm saw the Stone,

The Sun-God [crossed again the horizon a second time.

[...u]p he traveled,

And to the Sky-God he went.

Something, in other words, has unsettled the “Sun God,” i.e., the Sun, causing it somehow to become “altered.” This passage recalls a similar “alteration” in the local celestial mechanics, that of the Babylonian “Sun God” Marduk, who “measured the structure of the deep” after his destruction of Tiamat in the *Enuma Elish*.

In any case, a “council of war” is soon called, as Tashmishu, brother of the Sun-God, cautions him about Ullikummi and his intentions:

“Why does he come...?”

That matter about which he comes,

(that) matter is grave,

It is not to be cast aside.

It is strong, the struggle!

It is strong, the battle!

It is the uproar of the Celestial Realm!

It is the land’s hunger and death!”

Once again, conflict and war is the context, but note again the multiple levels on which the text operates, for the “grave matter” that is “not to be cast aside” is nothing less than “the uproar of the Celestial Realm.” That is, the text may be - and it is my belief that it is - operating here on two levels simultaneously, for the “uproar of the Celestial realm” clearly implies a chaotic and unstable situation in celestial mechanics, as well as an actual revolt or warfare in the pantheon itself. Were it not for the odd reference previously to the “place of the belt” one could perhaps dismiss these two levels of meaning as just another metaphor for the catastrophe caused by an impact or near miss of a planet with a meteor. But meteors and volcanoes do not neatly arrange themselves in the geometric relationship of Orion’s belt.

The violent destructive powers of the Ullikummi Stone are clearly attested by the text:

And the King of Kummiya³⁸² set his face,

He set his face upon the dreadful (basalt-) stone,

And he saw the dreadful (basalt-) stone,

And from his anger his [...] became changed.

And the Sky-God sat down on the ground,

And his tears flowed forth like streams.

The Sky-God, his eyes tearful, spoke these words:

“Who can endure it any longer, this one’s violence?
And who can fight any longer?
And who can endure it any longer, this one’s fearfulness?”

The Ullikummi “Stone” was clearly an object of great power, and once again it seems prudent to point out the resemblance of the Ullikummi text to the “Rostau” of the Edfu texts, and the resemblance of both to Giza. It seems a plausible speculation then to associate the Giza-Rostau-Ullikummi with weaponry of some sort.

The Ullikummi text then alludes to yet another theme paralleled in other ancient Near Eastern texts such as the *Enuma Elish*, for it refers to the manipulation of extremely severe weather as a weapon of war. Once the power of the “Stone” has been lamented, Tashmishu

Called for the thunder-storms;
The rains and winds which break the rock for ninety “furlongs.”

....
[...The Sky-God] took a stand to fight.
Then he took the battle gear,
And he took the carts,
And he brought the clouds from the Celestial Realm.
And the Sky-God set his face on the (basalt-) stone,
And he saw him.

In other words, weather is again a weapon in a vast celestial conflict, only in this case it is a weapon specifically directed against the Ullikummi Stone “in the midst of the sea.” The scale of forces is thus cosmic on both sides, for a little further on the Ullikummi text relates that the

(basalt-)stone his body [...]
[...]
And he shook the Celestial Realm.

In spite of the breaks in the text, it appears that the Ullikummi Stone, reacted to this terrific weather weapons assault with a response that “shook the Celestial Realm,” i.e., by altering it at its very foundations. An even more interesting statement is related a little further on:

And the (basalt-) stone rose above Hebat and the temple:
So that Hebat could not hear news of the Gods,
And she could not see with her eyes the Sky-God ...

Something, in other words, was interfering with *communications*.

The destructive power of the Ullikummi is referred to somewhat later in the text, when Ea-Enki goes to Upelluri to relay to him the news:

Ea began to speak again to Upelluri:

“Do you not know, O Upelluri?
Has no one brought you word?
Do you not know him,
The swift God whom Kumarbi fashioned against the Gods?
And that Kumarbi [has made] death plans against the Sky-God,
And fashions a rebel against him?
The Basalt-stone who grew in the water,
Do you not know him?

Note now that the Stone that “grew in the water,” paralleling the Giza-Rostau references in the Edfu texts, is clearly associated with rebellion, and specifically, with “death plans against the Sky-God.” It would appear then that the Ullikummi Stone is connected with the very power to draw upon and alter the power of the heavens, i.e., it is able to utilize the fabric of the local space-time medium itself.

In any case, Ea-Enki formulates a plan to undo this power of the Ullikummi by undercutting its foundations:

And they shall bring out the former saw,
With which they cut apart the Celestial Realm and the Earth,
[And...] saw under the feet of Ullikummi, the Basalt-stone,
Whom Kumarbi raised as a rebel against the Gods.

Ea-Enki then commands Tashmishu to

“...go and fight him again!
The Basalt-stone shall no longer stand as a spear-point!”

A summary of what the text implies is now in order.

1. It is clear that the passages of the Ullikummi text cited here are capable of a catastrophist interpretation in two ways:
 - a. As a catastrophe involving *comets* or meteorites, and the resulting chaos and destruction caused by the impact on or near miss of the earth caused by a large enough celestial body, as the repeated references to the “Celestial Realm” would imply. But as was seen, the translation of “basalt-stone” as “meteorite-stone” was done in service of this interpretation, whereas the most noted translators of the text prefer “basalt-stone”, which would exclude this interpretation, and favor the following:
 - b. As a catastrophe involving massive volcanic activity, an interpretation favored by the text’s repeated references to this Stone arising “out of the sea.” But as was also seen, this interpretation cannot make sense of the curious reference to the “place of the belt” in connection with the “Stone,” a reference clearly implying some association of the “Stone” with the three stars of Orion’s belt. Thus,

2. The repeated references in the Ullikummi text to the Stone standing out of the midst of the sea not only parallels the similar picture of the Edfu texts to the “Rostau,” the association of the Ullikummi with Giza would appear to be strengthened by the reference to the Place of the Belt i.e., to Orion’s belt. Thus,
3. The Ullikummi text refers to something clearly artificial, involving Stones that rise “out of the sea,” and associates these stones with massive conflict and disturbances in the heavens, and with a “rebellion.” The clear implication of the Ullikummi text is that this place where the Stone rises out of the sea is possessed of enough power to affect and destroy things on a celestial scale.
4. Like the *Enuma Elish*, the Ullikummi text also refers to weather as a weapon, and clearly implies the alteration of the geometry of local space. This alteration or destruction of the original geometry as a result of this conflict and rebellion is *itself* not only a sign of that rebellion but a kind of rebellion in its own right, since it no longer reflects the original order of things, presumably the order that the “gods” or God originally ordained.

Certainly impacts from comets and meteors have occurred and can wreak untold destruction on the planetary bodies that endure them.

But so can wars fought with weapons of sufficient power to scar whole regions of, or to explode, an entire planet. And with the Ullikummi text and its obvious reference to Giza in the context of a conflict involving cosmically scaled forces, one is no longer looking at the metaphors for a naturalist religion of “exploded planet cults” ala Alan Alford. One is looking at very real, very artificial structures that are no mere metaphors. This implies, however unbelievable it may seem, that the war was also real, that it was interplanetary, and that it happened millennia ago.

D. When It Happened: Further Indications

1. *The Sumerian Kings List*

The Sumerian Kings List provides a strong — and as will be seen, important — indication of when these wars and catastrophes took place. In order to understand its significance, only its end will be cited in full, but readers not wishing to read the whole context may skip to pages 192 and 198-199 for the central points.

After the kingship descended from heaven, the kingship was in Eridug. In Eridug, Alulim became king; he ruled for 28800 years. Alaljar ruled for 36000 years.

2 kings; they ruled for 64800 years.

Then Eridug fell and the kingship was taken to Bad-tibira.

In Bad-tibira, En-men-lu-ana ruled for 43200 years. En-men-gal-ana ruled for 28800 years. Dumuzid, the shepherd, ruled for 36000 years.

3 kings; they ruled for 108000 years.

Then Bad-tibira fell (?) and the kingship was taken to Larag.

In Larag, En-sipad-zid-ana ruled for 28800 years. 1 king; he ruled for 28800 years.

Then Larag fell (?) and the kingship was taken to Zimbir.

In Zimbir, En-men-dur-ana became king; he ruled for 21000 years.

1 king; he ruled for 21000 years.

Then Zimbir fell (?) and the kingship was taken to Curuppag. In Curuppag, Ubara-Tutu became king; he ruled for 18600 years.

1 king; he ruled for 18600 years.

In 5 cities 8 kings; they ruled for 241200 year.

Then the flood swept over.

After the flood had swept over, and the kingship had descended from heaven, the kingship was in Kic.

In Kic, Jucur became king; he ruled for 1200 years. Kullassina-bel ruled for 960 (ms. P2+L2 has instead: 900) years. Nanjiclicma ruled for (ms. P2+L2 has:) 670 (?) years. En-tarah-ana ruled for (ms. P2+L2 has:) 420 years, 3 months, and 3 1/2 days. Babum ruled for (ms. P2+L2 has:) 300 years. Puannum ruled for 840 (ms. P2+L2 has instead: 240) years. Kalibun ruled for 960 (ms. P2+L2 has instead: 900) years. Kalumum ruled for 840 (mss. P3+BT14, Su have instead: 900) years. Zuqaqip ruled for 900 (ms. Su1 has instead: 600) years. (In mss. P2+L2, P3+BT14, P5, the 10th and 11th rulers of the dynasty precede the 8th and 9th.) Atal (mss. P2+L2, P3+BT14, P5 have instead: Aba) ruled for 600 years. Macda, the son of Atab ruled for 840 (ms. Su1 has instead: 720) years. Arwium, the son of Macda, ruled for 720 years. Etana, the shepherd, who ascended to heaven and consolidated all the foreign countries, became king; he ruled for 1500 (ms. P2+L2 has instead: 635) years. Balih, the son of Etana, ruled for

400 (mss. P2+L2, Su1 have instead: 410) years. En-me-nuna ruled for 660 (ms. P2+L2 has instead: 621) years. Melem-Kic, the son of En-me-nuna, ruled for 900 years. (ms. P3+BT14 adds:) 1560 are the years of the dynasty of En-me-nuna. Barsal-nuna, the son of En-me-nuna (mss. P5, P3+BT14 have instead: Barsal-nuna) ruled for 1200 years. Zamug, the son of Barsal-nuna, ruled for 140 years. Tizqar, the son of Zamug, ruled for 305 years. (ms. P3+BT14 adds:) 1620 + X Ilku ruled for 900 years. Iltasadum ruled for 1200 years. En-men-barage-si, who made the land of Elam submit, became king; he ruled for 900 years. Aga, the son of En-men-barage-si, ruled for 625 years. (ms. P3+BT14 adds:) 1525 are the years of the dynasty of En-men-barage-si.

23 kings; they ruled for 24510 years, 3 months, and 3 1/2 days.

Then Kic was defeated and the kingship was taken to E-ana.

In E-ana, Mec-ki-aj-gacer, the son of Utu, became lord and king; he ruled for 324 (ms. P2+L2 has instead: 325) years. Mec-ki-aj-gacer entered the sea and disappeared. Enmerkar, the son of Mec-ki-aj-gacer, the king of Unug, who built Unug (mss. L1+N1, P2+L2 have instead: under whom Unug was built), became king; he ruled for 420 (ms. TL has instead: 900 + X) years. (ms. P3+BT14 adds:) 745 are the years of the dynasty of Mec-ki-aj-gacer. (ms. TL adds instead: he ruled for 5 + X years.) Lugalbanda, the shepherd, ruled for 1200 years. Dumuzid, the fisherman, whose city was Kuara, ruled for 100 (ms. TL has instead: 110) years. (ms. P3+BT14 adds:) He captured En-me-barage-si single-handed. Gilgamec, whose father was a phantom (?), the lord of Kulaba, ruled for 126 years. Ur- Nungal, the son of Gilgamec, ruled for 30 years. Udul-kalama, the son of Ur- Nungal (ms. Su1 has instead: Ur-lugal), ruled for 15 years. Laba'cum ruled for 9 years. En-nun-tarah-ana ruled for 8 years. Mec-he, the smith, ruled for 36 years. Melem-ana (ms. Su2 has instead: Til-kug (?)) ruled for 6 (ms. Su2 has instead: 900) years. Lugal-kitun (?) ruled for 36 (ms. Su2 has instead: 420) years.

12 kings; they ruled for 2310 (ms. Su2 has instead: 3588) years.

Then Unug was defeated and the kingship was taken to Urim.

In Urim, Mec- Ane-pada became king; he ruled for 80 years. Mec-ki-aj- Nanna (ms. P2+L2 has instead: Mec-ki-aj-nuna), the son of Mec- Ane-pada, became king; he ruled for 36 (ms. P2+L2 has instead: 30) years. Elulu ruled for (mss. L1+N1, P2+L2, P3+BT14 have:) 25 years. Balulu ruled for (mss. L1+N1, P2+L2, P3+BT14 have:) 36 years. (mss. L1+N1, P2+L2 have:)

4 kings; they ruled for (mss. L1+N1, P2+L2, P3+BT14 have:) 171 years.

Then Urim was defeated and the kingship was taken to Awan.

In Awan, became king; he ruled for years..... ruled for years..... ruled for 36 years.

3 kings; they ruled for 356 years.

Then Awan was defeated and the kingship was taken to Kic.

In Kic, Susuda, the fuller, became king; he ruled for 201 + X years. Dadasig ruled for (ms. vL has:) 81 years. Mamagal, the boatman, ruled for 360 (ms. L1+N1 has instead: 420) years. Kalbum, the son of Mamagal (ms. WB has instead: Magalgal), ruled for 195 (ms. L1+N1 has instead: 132) years. Tuge (?) ruled for 360 years. Men-nuna, (ms. L1+N1 adds:) the son of Tuge

(?), ruled for 180 years. (in mss. L1+N1, TL, the 7th and 8th rulers of the dynasty are in reverse order) ruled for 290 years. Lugalju ruled for 360 (ms. L1+N1 has instead: 420) years.

8 kings; they ruled for 3195 (ms. L1+N1 has instead: 3792) years.

Then Kic was defeated and the kingship was taken to Hamazi.

In Hamazi, Hadanic became king; he ruled for 360 years.

1 king; he ruled for 360 years.

Then Hamazi was defeated and the kingship was taken (ms. P3+BT14 has instead: was returned a second time) to Unug.

(In mss. IB, L1+N1, TL, the 2nd dynasty of Unug of ll. 185- 191 is preceded by the 2nd dynasty of Urim of ll. 192-203.)

In Unug, En-cakanca-ana became king; he ruled for 60 years. Lugal-ure (ms. P3+BT14 has instead: Lugal-kinice-dudu (?)) ruled for 120 years. Argandea ruled for 7 years. (ms. L1+N1 has:)

3 kings; they ruled for (ms. L1+N1 has:) 187 years.

Then Unug was defeated (ms. TL has instead: destroyed) and the kingship was taken to Urim.

In Urim, Nani became king; he ruled for (ms. vD has:) 120 + X (ms. IB has instead: 54 + X years. Mec-ki-aj- Nanna, the son of Nani, ruled for (ms. vD has:) 48 years., the son (?) of ruled for (ms. IB has:) 2 years. (ms. IB has:)

3 kings; they ruled for (ms. IB has:) 582 (ms. TL has instead: 578) years. (ms. vD has instead: 2 kings; they ruled for 120 + X years.)

Then Urim was defeated (ms. TL has instead: destroyed) and the kingship was taken to Adab.

In Adab, Lugal-Ane-mundu became king; he ruled for (mss. L1+N1, TL have:) 90 years. (mss L1+N1, TL have:)

1 king; he ruled for (mss. L1+N1, TL have:) 90 years.

Then Adab was defeated (ms. TL has instead: destroyed) and the kingship was taken to Mari.

In Mari, Anbu (?) became king; he ruled for 30 (ms. TL has instead: 90) years. Anba (?), the son of Anbu (?), ruled for 17 (ms. TL has instead: 7) years. Bazi, the leatherworker, ruled for 30 years. Zizi, the fuller, ruled for 20 years. Limer, the gudu priest, ruled for 30 years. Carrum-iter ruled for 9 (ms. TL has instead: 7) years.

6 kings; they ruled for 136 (ms. TL has instead: 184) years.

Then Mari was defeated (ms. TL has instead: destroyed) and the kingship was taken to Kic.

In Kic, Kug-Bau, the woman tavern-keeper, who made firm the foundations of Kic, became king; she ruled for 100 years.

1 king; she ruled for 100 years.

Then Kic was defeated (ms. TL has instead: destroyed) and the kingship was taken to Akcak.

In Akcak, Unzi became king; he ruled for 30 years. Undalulu ruled for 6 (mss. L1+N1, S have instead: 12) years. Urur ruled for (ms. IB has instead: was king (?) for) 6 years. Puzur- Niral ruled for (mss. IB, L1+N1, S, Su1 have:) 20 years. Icu- Il ruled for (mss. IB, L1+N1, S, Su have:) 24 years. Cu- Suen, the son of Icu-II, ruled for (mss. IB, L1+N1, S, TL have:) 7 (ms. Su has instead: 24) years. (mss. S, Su1, TL have:)

6 kings; they ruled for (mss. L1+N1, S, TL have:) 99 (ms. Su1 has instead: 116) years (ms. IE has instead: 5 kings; they ruled for (ms. IB has:) 87 years).

Then Akcak was defeated (ms. S has instead: Then the reign of Akcak was abolished) and the kingship was taken to Kic. (mss. IB, S, Su1, Su3+Su4 list the 3rd and 4th dynasty of Kic of ll. 224-231 and ll. 244-258, respectively, as one dynasty)

In Kic, Puzur-Suen, the son of Kug-Bau, became king; he ruled for 25 years. Ur-Zababa, the son of Puzur-Suen, ruled for 400 (mss. P3+BT14, S have instead: 6) (ms. IB has instead: 4 + X years. (ms. P3+BT14 adds:) 131 are the years of the dynasty of Kug-Bau. Zimudar (ms. TL has instead: Ziju-iake) ruled for 30 (ms. IB has instead: 30 + X) years. Uß,,i-watar, the son of Zimudar (ms. TL has instead: Ziju-iake), ruled for 7 (ms. S has instead: 6) years. Ectar-mut ruled for 11 (ms. Su1 has instead: 17 (?)) years. Icme-Camac ruled for 11 years. (ms. Su1 adds:) Cu-ilicu ruled for 15 years. Nanniya, the jeweller, (ms. Su1 has instead: Zimudar) (ms. IB has instead:) ruled for 7 (ms. S has instead: 3) years. 7 kings; they ruled for 491 (ms. Su1 has instead: 485) years (ms. S has instead:

7 kings; they ruled for 491 years.

Then Kic was defeated (ms. S has instead: Then the reign of Kic was abolished) and the kingship was taken (ms. P3+BT14 has instead: was returned a third time) to Unug. (ms. IB omits the 3rd dynasty of Unug of ll. 258-263)

In Unug, Lugal-zage-si became king; he ruled for 25 (ms. P3+BT14 has instead: 34) years.

1 king; he ruled for 25 (ms. P3+BT14 has instead: 34) years.

Then Unug was defeated (ms. S has instead: Then the reign of Unug was abolished) and the kingship was taken to Agade.

In Agade, Sargon, whose father was a gardener, the cupbearer of Ur-Zababa, became king, the king of Agade, who built Agade (ms. L1+N1 has instead: under whom Agade was built); he ruled for 56 (ms. L1+N1 has instead: 55) (ms. TL has instead: 54) years. Rimuc, the son of Sargon, ruled for 9 (ms. IB has instead: 7) (ms. L1+N1 has instead: 15) years. Man-icticcu, the older brother of Rimuc, the son of Sargon, ruled for 15 (ms. L1+N1 has instead: 7) years. Naram-Suen, the son of Man-icticcu, ruled for (mss. L1+N1, P3+BT14 have:) 56 years. Car kali-carri, the son of Naram-Suen, ruled for (ms. L1+N1, Su+Su4 have:) 25 (ms. P3+BT14 has instead: 24) years. (ms. P3+BT14 adds:)

157 are the years of the dynasty of Sargon.

Then who was king? Who was the king? (ms. Su3+Su4 has instead: who was king? Who indeed was king?) Irgigi was king, Imi was king, Nanûm was king (in mss. L1+N1, Su3+Su4 Imi and Nanûm are in reverse order), Ilulu was king, and the (mss. P3+BT14, S have:) 4 of them ruled for only (mss. P3+BT14, S have:) 3 years. Dudu ruled for 21 years. Cu- Durul, the son of

Dudu, ruled for 15 (ms. IB has instead: 18) years.

11 kings; they ruled for 181 years (ms. S has instead: 12 kings; they ruled for (ms. S has:) 197 years) (mss. Su1, Su3+Su4, which omit Dudu and Cu-Durul, have instead: 9 kings; they ruled for (ms. Su1 has:) 161 (ms. Su3+Su4 has instead: 177) years.

Then Agade was defeated (ms. S has instead: Then the reign of Agade was abolished) and the kingship was taken to Unug.

In Unug, Ur-nijin became king; he ruled for 7 (mss. IB, S have instead: 3) (ms. Su1 has instead: 15) (ms. Su3+Su4 has instead: 30) years. Ur-gigir, the son of Ur-nijin, ruled for 6 (ms. IB has instead: 7) (ms. Su1 has instead: 15) (ms. Su3+Su4 has instead: 7) years. Kuda ruled for 6 years. Puzur-ili ruled for 5 (ms. IB has instead: 20) years. Ur-Utu ruled for 6 (ms. Su3+Su4 has instead: Ur-Utu), the son of Ur-gigir, ruled for 25 (ms. Su1 has instead: Lugal-melem, the son of Ur-gigir, ruled for 7) years.

5 kings; they ruled for 30 (ms. IB has instead: 43) (mss. Pđ+Ha, S have instead: 26) years (ms. Su3+Su4, which omits Kuda and Puzur-ili, has instead: 3 kings; they ruled for (ms. Su3+Su4 has:) 47 years). Unug was defeated (ms. S has instead: Then the reign of Unug was abolished) and the kingship was taken to the army (ms. Su3+Su4 has instead: land) of Gutium.

In the army (ms. Su3+Su4 has instead: land) of Gutium, at first no king was famous; they were their own kings and ruled thus for 3 years (ms. L1+N1 has instead: they had no king; they ruled themselves for 5 years). Then Inkicuc (ms. Su3+Su4 has instead:) ruled for 6 (ms. L1+N1 has instead: 7) years. Zarlagab ruled for 6 years. Culme (ms. L1+N1 has instead: Yarlagac) ruled for 6 years. Silulumec (ms. Mi has instead: Silulu) ruled for 6 (ms. G has instead: 7) years. Inimabakec ruled for 5 (ms. Mi has instead: Duga ruled for 6) years. Igecauc ruled for 6 (ms. M has instead: Ilu-an (?) ruled for 3) years. Yarlagab ruled for 15 (ms. Mi has instead: 5) years. Ibate ruled for 3 years. Yarla (ms. L1+N1 has instead: Yarangab (?)) ruled for 3 years. Kurum (ms. L1+N1 has instead:) ruled for 1 (ms. Mi has instead: 3) years. Apil-kin ruled for 3 years. La-erabum (?) ruled for 2 years. Irarum ruled for 2 years. Ibratum ruled for 1 year. Hablum ruled for 2 years. Puzur-Suen, the son of Hablum, ruled for 7 years. Yarlaganda ruled for 7 years. ruled for 7 years. Tiriga (?) ruled for 40 days.

21 kings; they ruled for (ms. L1+N1 has:) 124 years and 40 days (ms. Su3+Su4 has instead: 25 years).

Then the army of Gutium was defeated (ms. TL has instead: destroyed) and the kingship was taken to Unug.

In Unug, Utu-hejal became king; he ruled for 427 years, days (ms. IB has instead: 26 years, 2 + X months, and 15 days) (ms. J has instead: 7 years, 6 months, and 15 days) (ms. TL has instead: 7 years, 6 months, and 5 days).

1 king; he ruled for 427 years, days (ms. J has instead: 7 years, 6 months, and 15 days) (ms. TL has instead: 7 years, 6 months, and 5 days).

Then Unug was defeated and the kingship was taken to Urim.

In Urim, Ur-Namma became king; he ruled for 18 years. Culgi, the son of Ur-Namma, ruled for 46 (mss. Su3+Su4, TL have instead: 48) (ms. P5 has instead: 58) years. Amar-Suena, the son

of Culgi, ruled for 9 (ms. Su3+Su4 has instead: 25) years. Cu-Suen, the son of Amar-Suena ruled for 9 (ms. P5 has instead: 7) (ms. Su1 has instead: 20 + X) (ms. Su3+Su4 has instead: 16) years. Ibbi-Suen, the son of Cu-Suen, ruled for 24 (mss. P5, Su1 have instead: 25) (ms. Su3+Su4 has instead: 15) (ms. TL has instead: 23 (?)) years.

4 kings; they ruled for 108 years (mss. J, P5, Su1, Su3+Su4 have instead: 5 kings; they ruled for (ms. P5 has:) 117 (ms. Su1 has instead: 120 + X) (ms. Su3+Su4 has instead: 123) years).

Then Urim was defeated (ms. P5 has instead: Then the reign of Urim was abolished). (ms. Su3+Su4 adds:) The very foundation of Sumer was torn out (?). The kingship was taken to Isin.

In Isin, Icbi-Erra became king; he ruled for 33 (ms. P5 has instead: 32) years. Cu-ilicu, the son of Icbi-Erra, ruled for 20 (ms. P5 has instead: 10) (ms. Su1 has instead: 15) years. Iddin-Dagan, the son of Cu-ilicu, ruled for 21 (ms. Su1 has instead: 25) years. Icme-Dagan, the son of Iddin-Dagan, ruled for (mss. P2, P5 have:) 20 (ms. Mi has instead: 18) years. Lipit-Ectar, the son of Icme-Dagan (ms. P2 has instead: Iddin-Dagan), ruled for (mss. L1+N1, P2, P5 have:) 19 years. Ur-Ninurta (mss. L1+N1, P2 add:) , the son of Ickur -- may he have years of abundance, a good reign, and a sweet life -- ruled for (ms. P5 has:) 28 years. Bur-Suen, the son of Ur-Ninurta ruled for 21 years. Lipit- Enlil, the son of Bur-Suen, ruled for 5 years. Erra-imitti ruled for 8 (mss. P5, TL have instead: 7) years. (ms. P5 adds:) ruled for 6 months. Enlil-bani ruled for 24 years. Zambiya ruled for 3 years. Iter-pica ruled for 4 years. Ur-dul-kuga ruled for 4 years. Suen-magir ruled for 11 years. (ms. P5 adds:) Damiq-ilicu, the son of Suen-magir, ruled for 23 years.

14 kings; they ruled for 203 years (ms. P5 has instead: 225 years and 6 months). (Mss. P2+L2, L1+N1 and P4+Ha conclude with a summary of the post-diluvium dynasties; the translation of ll 378- 431 uses numerical data from each mss. but follows the wording of P2+L2 and L1+N1)

A total of 39 kings ruled for 14409 + X years, 3 months and 3 1/2 days, 4 times in Kic.

A total of 22 kings ruled for 2610 + X years, 6 months and 15 days, 5 times in Unug.

A total of 12 kings ruled for 396 years, 3 times in Urim.

A total of 3 kings ruled for 356 years, once in Awan.

A total of 1 king ruled for 420 years, once in Hamazi.

16 lines missing

A total of 12 (?) kings ruled for 197 (?) years, once in Agade.

A total of 21 (ms. P4+Ha has instead: 23) kings ruled for 125 years and 40 days (ms. P4+Ha has instead: 99 years), once in the army of Gutium.

A total of 11 (ms. P4+Ha has instead: 16) kings ruled for 159 (ms. P4+Ha has instead: 226) years, once in Isin.

There are 11 cities, cities in which the kingship was exercised.

A total of 134 (ms. P4+Ha has instead: 139) kings, who altogether ruled for 28876 + X (ms. P4+Ha has instead: 3443 + X) years. [383](#)

A number of things may now be noted about this odd list.

First, observe the length of the reigns of the individual kings mentioned. Prior to the Deluge, the lengths are extraordinarily long, which has led most conventionally minded scholars to dismiss the List's historical value. After all, such extraordinarily long reigns means equally extraordinarily long life spans, or at the very minimum, unusual permanence and staying power of a very few dynasties. Similarly, the assertion that "kingship descended" to the earth from the heavens is understood to be a metaphorical reference typical for the region, as kings sought to legitimize their authority by claiming their divine right to rule by virtue of a descent from the gods.

Secondly, note that 241,200 years passed from the "descent of kingship" to the Deluge itself.

Thirdly, observe that the list is clearly divided into a pre- and a post-Deluge period by the succinct statement, "In 5 cities 8 kings; they ruled for 241,200 years. Then the flood swept over." Then follows the post-Deluge list, in which the reigns and therefore the life-spans of the kings and their associated cities become progressively shorter, until at last they enter the realm of "reality", becoming normal for human beings. In this, there is an odd parallel to the biblical account of the life-spans of the pre- and post-Deluge lives of the Patriarchs and descendents from Adam.

Fourthly, note that the total length of time from the Deluge to the end of the Kings List is "28876 + X (ms. P4+Ha has instead: 3443 + X) years," that is, 28,876 years, give or take a few years depending on which manuscript tradition one follows.

But what do these numbers, and the curious division of the List into pre- and post-Deluge sections, mean? R. A. Boulay comments as follows:

The *King List* attributes reigns of legendary and incredible lengths to many of the rulers of the earlier antediluvian kings. In this sense, it affirms the enormous lifespans of the Patriarchs of the Old Testament.

These lifespans in the Sumerian *King List* has been a source of wonder and puzzlement. By current standards, the numbers of the antediluvians are completely fanciful. These huge numbers are consistent throughout the *King List* and therefore seem not to be erroneous. While a rational explanation has thus far escaped historians, most researchers feel there must be some underlying logic to these large numbers since a parallel can be found in the enormous lifespans of the antediluvian Patriarchs.^{[384](#)}

Indeed, since one very important Old Testament patriarch, Abraham, originated from this region, the odd connection, plus the Old Testament's own division of life spans into two sections, the antediluvian, and the post-diluvian life spans, where, like the Sumerian King List the life spans of the patriarchs declines progressively to what is now a normal human lifespan, the connection would seem to be more than coincidental.

Something else is at work in both cases.

Boulay offers one explanation, and that is that the reigns and therefore the long life spans of the antediluvian kings is a reflection of the Sumerian numerical system itself.

It was not unusual for the ancient to compute time by other than normal Earth years such as, for example, in the *Book of Jubilees*, where a Jubilee year is equivalent to 50 regular years. That is

equal to seven week years (a week year was seven years) and one year added for atonement, when all activities were supposed to cease.

...

(The Sumerians') numerical system was sexagesimal in character and they made use of the factor of 10 as well as 6. Thus the sequence 1, 10, 60, 360, 600, 3600 takes on a special meaning in their mythology. If the duration of the various terms of kingship are presented graphically, it becomes obvious that this sexagesimal system underlies the fabulous numbers of the *King List*. Called a SHAR by the Sumerians, the number 3600 appears to have a special meaning in this list. It can be seen that with slight adjustment, the years of reign of the Sumerian kings are divisible by this number. It indicates that the term of reign for a Sumerian antediluvian king was presumably a "shar" — probably renewable every ³⁶⁰⁰ years.³⁸⁵

But this really solves nothing. In fact, it makes the problem of the abnormally lengthy reigns and life spans even more intractable, for if one were to multiply the total length of the reigns of the antediluvian kings, 241,200 years, by the length of a "shar," 3600 years, one would obtain the figure of 868,300,000 years, roughly one fifth the supposed age of the earth!

Moreover, this "solution" does not really place the events referred to in the Kings List in synch with any date for the cosmic catastrophe advanced by Van Flandern's Exploded Planet Hypothesis. One is left with dates — 241,200 years ago or 868,300,000 years ago — hovering in mid-air with no connection otherwise to any historical or scientific events, such as the dates of Van Flandern's Multiple Exploded Planet Hypothesis, which, it will be recalled, posited two major explosions a 65,000,000 and 3,200,000 years ago. And Boulay's method of "resolution" places any historical basis for the Kings List far beyond the normal reckoning of the Deluge as being ca. 10,500 B.C.

It is the connection to the similarly long life spans of the Old Testament patriarchs that may in fact provide a resolution of the dilemma, for the book of Genesis indicates the existence of yet another unit of time, a unit of 120 years, which we may call a "Flood Year" for convenience. It should also be noted that while 120 years is not a standard unit of significance in the Sumerian sexagesimal numerical system, it is nonetheless a unit easily harmonized with it.

If one takes the ante- and post-diluvian ages of the kings from the Kings List, and multiplies it by this new number, 120 years, some *very* interesting results begin to appear. The post-diluvian total reign of kings, 28,876 years, multiplied by this "Flood Year", yields a date of 3,455,120 years ago, *roughly the same time as Van Flandern's second major exploding planet event of 3,200,000 years ago*. And if one takes the antediluvian figure of 241,200 years from the Kings List and does the same thing, one obtains a date of 28,944,000 years ago, which is very roughly *one half* of Van Flandern's date for the earliest exploding planet event of 65,000,000 years ago.³⁸⁶

These results suggest that the connection between the biblical and Sumerian traditions is not only more than coincidental, but viewed in this way, also suggest that the Sumerian Kings List is somehow tied to at least one, and possibly both, of the celestial events of Van Flandern's Multiple Exploded Planet Hypothesis. But let us note which event: the 3,200,000 years ago event, the one that Van Flandern originally favored as the "main explosion."

This is significant, for now there is a connection between an ancient textual tradition and the

celestial catastrophes of Van Flandern's Hypothesis. There are two hidden implications of this connection. First, it would imply that there was a major flood event on earth ca. 3,200,000 years ago, with attendant meteoric bombardment and so on. Given that Van Flandern's 3,200,000 years date is for the explosion of a smaller, moon-sized planet, evidence of this event on earth should be found, though it will not be of the major nature as that of the major event at 65,000,000 years ago. Secondly, the connection between the two also strongly suggests that this event was an *observed* event and, if one takes this new speculative interpretation of the Kings List at face value, an observed event that is clearly tied to human history and civilization. This implies both an antiquity to mankind *and* an antiquity of civilization predating standard academic theory and the archaeological evidences supporting it. The archaeological evidence for our interpretation will be discussed later. In any case, the Kings List establishes an important connection between an ancient textual tradition and Van Flandern's hypothesis.

The Kings List, viewed in this way, also suggests one other thing highly important for our discussion: it not only suggests a connection between the antediluvian kings and Van Flandern's second "minor" event, but also suggests something far older, a connection to an even older time, and perhaps to even older, and much more catastrophic events.

In any case, one may draw some basic conclusions from this chapter concerning the timing and connections of the events:

1. There was a "primordial revolt" soon after the initial creation of the "primeval mound" from the primeval "waters;"
2. This revolt may pre-date the 65,000,000 years event of Dr. Van Flandern, or may be synonymous with it;
3. A subsequent second event occurred ca. 3,200,000 years ago, which may also be the event alluded to in the ancient texts describing the war; this benchmark event was found to be roughly corroborated by the Sumerian Kings List;
4. A strong textual tradition exists which connects this conflict to serpents and to Mars.

And now, as they say, the plot is about to thicken...

8.

THE STORY OF THE STONES: A LITTLE MORE WHY

“The Hero had conquered the Mountains. As he moved across the desert... ”

The Exploits of Ninurta

A. The Technological Motivation

From the Judeo-Christian traditions of the Fall of Lucifer, to the Hindu epics with their legends of titanic wars of the gods and wanton slaughter, to the Sumerians, Babylonians, Assyrians, Egyptians, and Greeks of antiquity, to the Aztecs, Toltecs, and other indigenous nations of North and South America, and to the Teutonic tribes of northern Europe and Scandinavia, almost every culture in the world has a tradition of the warfare, and in many cases of the revolt, of the gods. The struggles and battles are epic in their scale, cosmic in the degree of their slaughter, and titanic in their scale of destruction. The weapons with which they were fought are so far-fetched — or advanced — that they were literally described in almost magical science fiction terms: the “thunderbolts” or “arrows” or “darts” of the gods; they were “the divine weapons.”

Many of these stories contain common elements, however, that in spite of the supposed isolation of these cultures from one another, appear to indicate a shared source or sources for their legends. And one of the strangest common elements to many of these legends concerns the theft or usurpation of some object or objects of power belonging to one god or set of gods, by another god or set of gods. And quite often, these objects of power are “magic stones,” or “power crystals.”

Thus, we come to one of the strangest motifs in the already strange hypothesis of a real, but very ancient, interplanetary war: What was the motivation for this cataclysmic cosmic warfare? What were these objects? And most importantly, what happened to them and to the “gods” and/or “people” that wielded them? As will be seen, one motivation of the war in many traditions is for the control of these technologies of power.

1. A Glance at the Breadth of the Theme

The breadth of the tradition of ancient “stones” or “crystals” of power is impressive, and before looking at the tradition that devotes the most detailed attention to it — the Sumerian — a glance at the wider context is in order.

From Mesoamerica, the Mayan *Popol Vuh* recounts the giving of a “power-crystal,” called the “Giron-Gagal,” to Balaam-Quitze by “‘the Great father’ of Patulan-Pa-Civan, the Mayas’ version of Atlantis.”³⁸⁷ According to Atlantologist Frank Joseph, the Giron-Gagal was a “symbol of power and majesty to make the peoples fear and respect the Quiches.”³⁸⁸ No explanation is given as to how mere crystal could do this, but the clear implication is that it was a component in a technological or ritual-cultural matrix, or both.

In Australia, aboriginal peoples have a tradition of a sunken “Land of Mystery” with a similar “power stone,” in this case a large “crystal cone” that had a “‘serpent’ winding up its length from bottom to top.”³⁸⁹

Even the Slavs have their own version of the “power stone” tradition. Their “Alatuir” was not only a “magic stone” but “the source of ultimate power” that resided at the very center of “Bouyan, a sunken island kingdom from which the ancestors of the Slavic peoples migrated to the European continent from the Western Ocean.”³⁹⁰

And one must not forget to mention the Slavic tradition of “magic stones” without recalling the curious association of Russian mystic and painter Nicholas Roerich with the so-called “Chintimani” Stone. From the Sanskrit for “magical stone from another world,” many researchers have interpreted this, following the catastrophist paradigm, to be a clear allusion to its being a meteorite. But Atlantologist Frank Joseph reports that there is “an exceptionally clear quartz crystal” now in the Moscow Museum that is the Chintimani Stone.

As if that were not enough, this curious tradition is known in China and Japan as well, where the stone is known as the “Jewel- That-Grants-All-Desires.” It was believed to have once “belonged to the Makara, a dragon- or dolphin-god, living in a palace at the bottom of the sea, underscoring its Atlantean provenance.”³⁹¹

Taken together, these disparate traditions would seem to underscore the idea of “magic stones” or “crystals of power” having once been components in a technology of power and hegemony.

2. *The Sumerian Tradition*

But no tradition underscores the role of “power stones” and their role in the War of the Pantheon and the Revolt of the Gods more than does the Sumerian.³⁹² Two legends are crucial in the exposition of this tradition: the *Legend of Nergal and Ereshkigal*, and *The Myth of Zu* or as he is sometimes known, *The Myth of Anzu*.

a. Nergal, the Storming of the Underworld, and the “Tablet of Wisdom ”

According to Assyriologist Stephanie Dalley, the earliest of the two versions of *The Legend of Nergal and Ereshkigal* was found in what at first glance appears to be a most unlikely place for the tablets of a Sumerian epic to be found: Tell el-Amarna in Egypt, and dates from the fifteenth or fourteenth centuries B.C!³⁹³ In my last book on the Giza Death Star hypothesis, I speculated on the possible though seemingly implausible link of the Babylonian god of Mars, war, revolt, and the underworld, Nergal, to the complex at Giza, and to the Martian ruins at Cydonia.³⁹⁴ The *Legend of Nergal and Ereshkigal* in its Tell el-Amarna version, while not directly supporting this very speculative connection, certainly does not contradict it.

In any case, the standard Babylonian version *The Legend of Nergal and Ereshkigal* recounts in a very few short lines Nergal’s storming of “the Seven Gates of the Underworld,” the names of the gates, and his oddly “biblical” six-day long lovemaking with the “legitimate” goddess of the underworld, Ereshkigal.³⁹⁵

But curiously, the Egyptian Tell el-Amarna version of the legend contains a twist toward the very end of the text, which suggests a *motivation* behind Nergal’s storming of the Seven Gates of the Underworld. Addressing the would-be usurper, the Queen of the Underworld, Ereshkigal, offers him an unusual deal:

“You can be my husband, and I can be your wife. I will let you seize
Kingship over the wide Earth! I will put the Tablet
Of wisdom in your hand! You can be master,
I can be mistress.”³⁹⁶

The implications are immediately obvious, for Nergal’s whole storming of the Underworld, following the older Amarna version of the text, would appear to be motivated by nothing less than a desire for global domination by means of some technology or symbol of authority represented by the “tablet of wisdom,” an object that appears to be intimately connected to “Kingship over the wide Earth.”

b. The Myth of (An)Zu: The Tablet of Destinies and the Causus Belli

A much more detailed and suggestive glimpse into the technological motivation for the War in the Pantheon is provided by the *Myth of (An)Zu*. Indeed, in this legend one gains a glimpse into the characters of the main players, their motivations, and suggestions of the incredible technologies and science with which the war was waged.

Here again the text comes in two versions. According to Sumerologist Stephanie Dalley once again, the “Old Babylonian” version consists of “a small portion of the tale” dating from “the early second millennium.”³⁹⁷ The Standard Babylonian version, “dating to the first millennium BC” was discovered on tablets of three or four columns, most of which were “found on the Late Assyrian sites of Ninevah, Tarbisu and Sultantepe,” although there is a tablet of unknown provenance from this textual tradition of the legend in a museum collection in the United States.³⁹⁸

As Dalley notes, the whole story of the Legend “centres around possession of the Tablet of Destinies.”³⁹⁹ The text is even more curious however, for the odd resemblance it paints of the gods Ninurta and Nergal:

The opening lines of the epic introduce the theme in the first person, representing the singer or poet, and are very closely comparable to the opening lines of *Erra and Ishum*. *Nergal and Ninurta are quite close in some aspects of their characters, and in Erra and Ishum the defeat of Anzu with a net and the conquest of asakku-demons are attributed to Nergal/Erra. The fight of Ninurta to defeat the asakku-demons is known from the mainly Sumerian epic story of cosmic warfare called Lugal-e, and a companion story An-gim.*⁴⁰⁰

The similarities between epics of the themes and characters of the two gods suggests the possibility that Ninurta and Nergal might be one and the same individual. As outlandish as that might seem at first glance, Dalley herself notes that one line of the *Erra and Ishum* epic actually “assimilates Nergal with Ninurta,”⁴⁰¹ so apparently someone in ancient times noticed the similarity as well.

In any case, the legend makes a number of important observations both about Ninurta, the technological motivations for the war, and the technological means by which it was fought. Ninurta is called “the powerful god, Ellil’s son, *Ekur’s child, leader of the Annunaki, focus of Eninnu.*”⁴⁰² Note the clear connection between Ninurta and the Annunaki, the beings equivalent with the “Nephilim” who fell from heaven and interbred with human beings. Here Ninurta is clearly called their “leader,” and this makes another connection or association with the god Nergal likely, since the leader of these Nephilim in the apochryphal *Book of Enoch* is, like Nergal, clearly associated with an armed *revolt*.⁴⁰³

(1) “Ekur’s Child:” Ninurta and Nergal: Identification or Association?

The other reference — “Ekur’s child” — is equally if not much more important, for the word “ekur” not only means mountains, but also signifies the artificial “mountains” of the pyramids and

ziggurats. In other words, Ninurta is clearly associated with *pyramids*, and if one recalls our “mountains \approx planets \approx pyramids” equation, then Ninurta is simultaneously a “child”, i.e., one “intimately associated with” a planet, and with pyramids.

This would seem to make his possible identification or association with Nergal even stronger, for as I presented in my book *The Giza Death Star Destroyed*, Nergal is a god of war and rebellion, is associated with a specific planet, Mars, and may be associated not only with Egypt, but with pyramids, the pyramids at Giza.⁴⁰⁴ And as leader of the Annunaki, Ninurta — if one adopt the biblical viewpoint for a moment — is also clearly associated with the whole attempt to create a “hybrid” or “chimeric” race, part human and part “god.”

However, even if one rejects this highly speculative identification of Ninurta with Nergal, and only views it as a strong and highly suggestive association, it is an important association, for Nergal is a personage of some importance, a regular Sumerian “jet-setter” who manages to turn up under various names almost everywhere in the ancient world’s various pantheons. Moreover, he is associated with some truly catastrophic activity.

On the “activity” side of things, it is Nergal along with other gods in the “Sumerian” pantheon, one of them notably being Ninurta, who wields one of the gods’ favorite “divine weapons”: the “abubu” or “flood weapon.”⁴⁰⁵ But Nergal also gets around. Under the name “Erra” he is the “god of war, hunting, and plague,” and, notes Dalley, the etymology for Erra as “scorched earth” is “probably incorrect,” though she does not state why.⁴⁰⁶ Yet another of his names translates into “lord who prowls by night,”⁴⁰⁷ a reference curiously reminiscent of biblical descriptions of Lucifer.⁴⁰⁸ Elsewhere Nergal was called “Erragal” and “Erakal” which were most likely the pronounced forms of Nergal according to Dalley, who adds the comment that the name was probably pronounced “Herakles in Greek.”⁴⁰⁹ Under his Sumerian name Gibil, Nergal is also the god of fire.⁴¹⁰ These characteristics of Nergal will, as we see, bear strong resemblance to those of Ninurta as we examine the text, making it clear that Nergal is at least “partly assimilated” with Ninurta. ⁴¹¹

(2) Ninurta and Nimrod: the Tower of Babel Moment

But enough about Nergal. Who is Ninurta?

Dalley makes one very significant and highly suggestive comment in the glossary to her book *Myths from Mesopotamia* under the entry for Ninurta, which she notes was “probably pronounced Nimrod”!⁴¹² Nimrod was, of course, the “mighty hunter” and empire-builder mentioned in the list of Noah’s descendents in the tenth chapter of the biblical book of Genesis. In this context, it is interesting that in the *eleventh* chapter the Tower of Babel incident is recounted. In other words, the context of the biblical accounts of Nimrod and the Tower of Babel suggests a connection between the two. And the connection may be more than contextual.

To see how, it is worth quoting what I said about the event in my book *The Giza Death Star Destroyed*:

There is another event that bears mentioning with regard to the decline of the paleoancient Very

High Civilization and its presumably unified physics and sophisticated technology: the Tower of Babel. The Old Testament affords a significant clue into the event that transformed the unified and paleoancient Very High Civilization into a multitude of squabbling and declined legacy cultures that resulted from it. The story is recounted in Genesis 11:1-9:

1. And the whole earth was of one language and of one speech.
2. And it came to pass, as they journeyed from the east, that they found a plain in the land of Shinar; and they dwelt there.
3. And they said one to another, Go to, let us make brick, and burn them thoroughly. And they had brick for stone, and slime had they for mortar.
4. And they said, Go to, let us build a city and *a tower whose top may reach unto heaven*; and let us make us a name, lest we be scattered abroad upon the face of the whole earth.
5. And the LORD came down to see the city and the tower, which the children of men builded.
6. And the LORD said, *Behold, the people is one, and they have all one language; and this they begin to do: and now nothing will be restrained from them, which they have imagined to do.*
7. Go to, let us go down, and there confound their language, that they may not understand one another's speech.
8. So the LORD scattered them abroad from thence upon the face of all the earth: and they left off to build the city.
9. Therefore is the name of it called Babel; because the LORD did there confound the language of all the earth: and from thence did the LORD scatter them abroad upon the face of all the earth.

I then commented as follows:

...The “Tower of Babel Moment” permits a further speculation: could the “one language” and “one people” be taken in the broadest sense, not only of one natural human language and one civilization, but of one *language of science*, a *unified* science and physics? And could the “one people” refer not only to that one paleoancient Very High Civilization, but also to the unifying cultural effects that “one language” and unified scientific worldview afforded it? Nothing in the biblical account precludes these possibilities, and indeed, there is a strong indication that the Tower may be the (Great) Pyramid itself, if one understands the “top which reaches to heaven” to be a metaphor of the Pyramid’s many dimensional analogs of local celestial mechanics. By a similar line of reasoning, a unified physics and science is implied in the divine observation that “nothing will be restrained from them, which they have imagined to do.” Clearly the “Tower” was no Renaissance painting of vast scaffolding and cranes groaning to lift massive weights to enormous heights. Something else entirely was at work. In this context, it might not be going too far to speculate that the destruction of the Tower of Babel may refer, in oblique terms, to the destruction of “the Great Affliction” and “Weapon,” the Great Pyramid. [413](#)

In other words, the “Tower of Babel” *was an “ekur”*, a mountain ziggurat or pyramid, the possession of the *physics* and technology of which allowed its possessor(s) to imagine to do “whatever they imagine to do” in the way of challenging the divine order. The “Tower” was, to put it succinctly, a very threatening device, *one well-suited to the ambitions of a Nimrod, a would be world-emperor, of a Ninurta... of a Nergal.*

(3) Ninurta, “Subduer of the Mountain of Stones”

With all this being said, we may return to the examination of the Myth of (An)Zu, for a little bit further from the passage where he has just been called “Ekur’s child,” another passage places Ninurta once again in close association with pyramids:

Listen to the praise of the powerful one’s strength,
Who subdued, who bound the Mountain of Stones in his fury,
Who conquered soaring Anzu with his weapon... [414](#)

Ninurta, in other words, renders a “Mountain of Stones” harmless, since the clear implication is that whatever “mountain” is being talked about, to bind it would imply that this “mountain” was being used for destructive purposes. Note also that the Mountain of Stones in this case is associated with the god Anzu. In other words, by defeating Anzu and binding the “Mountain of Stones,” possession of the mountain has changed hands. Ninurta-Nimrod (-and-Nergal?) is now in possession of it.

But what weapons did Ninurta use to achieve this feat?

The answer to this question follows a little further on in the text:

At his shout [
The south wind [
The powerful [] wind [
The mass [
Whirlwinds [
They met and [
The four winds [[415](#)

The text, while in a greatly deteriorated condition, suggests that some form of *weather weaponry* was used by Ninurta, a fact strongly reminiscent of Tiamat’s arsenal as recorded in the *Enuma Elish*. [416](#)

(4) The Motivation for the War: The Theft of Hegemony-Bestowing Technology

What brought on this state of affairs was Enlil's appointment of (An)Zu to high position, a position in which the epic clearly records (An)Zu is tempted by the awesome power Enlil wields:

(Anzu's) eyes would gaze at the trappings of Ellil-power:

His lordly crown, his robe of divinity,

The Tablet of Destinies in his hands. Anzu gazed,

And gazed at Duranki's god, the father of the gods,

And fixed his purpose, to usurp the Ellil-power.

Anzu often gazed at Duranki's god, father of the gods,

And fixed his purpose, to usurp the Ellil-power.

"I shall take the gods' Tablet of Destinies for myself

And control the orders for all the gods,

*And shall possess the throne and be master of rites!"*⁴¹⁷

In other words, Enlil (called Ellil in the text) did not wield supreme power and hegemony in his own right; it was dependent on the possession of the "Tablet of Destinies," an object that conferred supreme power, a *technology*. More about this "Tablet of Destinies" in a moment. In any case, Anzu steals the Tablet of Destinies while Enlil was taking a bath, flees, and goes into hiding!⁴¹⁸

But there is something else to notice here: this is the *second* time we have encountered the theft of the Tablet of Destinies, and it is the second time that a war ensued for their recovery. The *first* time was Tiamat's theft of the Tablet, and the subsequent war with Marduk, as recounted in the *Enuma Elish*.⁴¹⁹ One must view these as two *separate* events rather than as two versions of the *same* event in that, other than their theft of the Tablet, the goddess Tiamat and the god Anzu's characters (not to mention their sex) are entirely different. Whereas with Ninurta and Nergal we can be reasonably confident that the gods were at least partially assimilated by the ancients, and whereas we might even reasonably speculate that they were in fact the same individual underlying their various legends, with Tiamat and Anzu we cannot. We are dealing with *two events*, an *extremely ancient* one in the War with Tiamat, and a *much less ancient though still quite old event* with the contest between Ninurta and Anzu. In other words, *the Mesopotamian legendary tradition is broadly compatible with Van Flandern's Multiple Exploded Planet Hypothesis, and its two planetary explosions at 65,000,000 and 3,200,000 million years ago.*

But we must go further than this, for if Van Flandern's two events are to be seen in connection with the Mesopotamian tradition as has been done here, then it is clear that that tradition ascribes both events to a war, to the use of technology; both wars were brought about by the presumed theft or usurpation of objects or technologies that conferred supreme power. Both wars had the same motivation, both had the same goal in the recovery of that technology, and both resulted in the destruction of an entire planetary body in our local solar system. We are looking, in other words, *at an extremely extended conflict spanning several millions of years, all for control or usurpation of a technology that confers supreme powers of destruction or hegemony.*

This being said, we may now note the *difference* between the "First Act" - between Tiamat and

Marduk - in this pantheonic war, recounted in the *Enuma Elish*, and the “Second Act” — between Ninurta-Nimrod and Anzu — recounted in *The Myth of (An)Zu*, for as will be seen in a moment, the latter myth *clearly connects this technology to “mountains” and stones*.

(5) The Pantheon Holds Council: The Lightning Weapon and the Inaccessible Mountain

At this juncture, predictably enough, the gods hold council to determine what is to be done about the theft, how to recover the stolen Tablet, and defeat Anzu. The first god to be addressed and requested to deal with the usurper is Adad, who is addressed in the following fashion:

“Powerful Adad, ferocious Adad, your attack cannot be deflected;
Strike Anzu with lightning, your weapon!
Your name shall be great in the great gods’ assembly,
You shall have no rival among the gods your brothers.⁴²⁰

Adad’s lightning weapon recalls the divine weapons and planetary discharges of the “gods” recounted in chapter two.

But even with such powerful weaponry in his possession, Adad demurs:

Adad answered the speech,
Addressed his words to Anu his father.

“Father, *who could rush off to the inaccessible mountain?*
Which of the gods your sons will be Anzu’s conqueror?
For he has taken the Tablet of Destinies for himself.
....His utterance has replaced that of Duranki’s god!
*He has only to command, and whoever he curses turns to clay!*⁴²¹

This passage is full of important clues as to the nature of the Tablets of Destinies and the war that followed their theft. First, note the reference to “the inaccessible mountain” that implies Anzu has taken refuge there. Likewise, note that his possession of the Tablets of Destinies makes even Adad think twice about using his powerful “lightning weapon,” since Anzu’s possession of the Tablet apparently makes him able to effect action at a distance: “He has only to “*command*” as opposed to Adad having to “*rush off*” to the place where Adad is, the “inaccessible mountain,” in order to strike a blow at him.

There is more to be observed here, for the text also seems to suggest that Anzu has taken one technology — the Tablets of Destinies - and combined it with another — the inaccessible mountain — to be able merely to command or effect destruction at a distance. Finally, if one takes our “mountain equals planets equals pyramids” equation from previous chapters and applies it here, then this passage takes on a multi-leveled significance: the “inaccessible mountain” could be a pyramid — and the Great Pyramid’s candidacy for “inaccessibility would seem to be quite strong — or a

planetary body, or *both*. In this respect, it is perhaps significant that the Tablets of Destinies may be an oblique metaphor for the “destinies of the planets” in a culture suffused with astrological lore. In short, it may be a metaphor for the type of celestial mechanics and associated physics connected to the whole idea of plasma and scalar physics.⁴²²

In any case, after Adad declines the dubious and risky honor of taking out Anzu and reacquiring control of the Tablets of Destinies, Gerra, who is identical with Nergal in this text, is addressed next, and pleaded with to use his “fire weapon” to “burn Anzu”, and the result is the same: Nergal, like Adad before him, declines the dubious “honor.”⁴²³

This pattern is repeated again and again with other gods all declining the risky attack on Anzu, until finally Ea formulates a plan to get Ninurta to do the deed:

The Lord of intelligence, wise one who dwells in the Apsu,
Formed an idea in the depths of his being;
Ea formed intelligence in his heart.
He told Anu what he was thinking in his inmost being.

“Let me give orders and search among the gods,
And pick from the assembly Anzu’s conqueror.

...

Have them call for me Belet-ili, sister of the gods,
Wise counselor of the gods her brothers.”

....

They called Belet-ilil, sister of the gods, to him..

...

(Then) Ea told the idea in the depths of his inmost being.

“Previously [we used to call you] Mami
(But) now [your name shall be] Mistress of All Gods.
Offer the powerful one, your superb beloved,
Borad of chest, who forms the battle array!
Give Ninurta, your superb beloved...”

...

[Mami listened to this speech of his...

[And Belet-ili the supreme uttered “Yes.” And she called her son into the gods’ assembly,
And instructed her favourite, saying to him

“...[I gave birth to all] the Igigi,
I created every [single one of the Annunaki],
And I created the [gods’] assembly. [I, Mami,]
[Assigned(?)] the Ellil-power [to my brother],
[Designated] the kingship of heaven for Anu.
Anzu has disrupted the kingship that I designated!
He has obtained for himself the Tablet of Destinies...
Muster your devastating battle force,
Make your evil winds flash as they march over him.
Capturing soaring Anzu

And inundate the earth, which I created — wreck his dwelling.
Let terror thunder above him,
Let fear (of?) your battle force shake in (?) him,
Make the devastating whirlwind rise up against him.
Set your arrow in the bow, coat it with poison.
Your form must keep changing, like a *gallu*-demon.
Send out a fog, so that he cannot recognize your features!
May your rays proceed above him.
Make a high, attacking leap: have glare
More powerful than Shamash generates...
Rush and inundate the mountain pastures
And slit the throat of wicked Anzu
The shall kingship enter Ekur again... [424](#)

The stratagem is simple: a mother half pleads, half orders her “favorite” son, with all the emotional manipulations that this entails, into a direct confrontation with the hated enemy Anzu. The whole passage thus has about it the air of reality and authenticity. Note also the important sequence that war leads to a flood with the repeated commands from Mami to “inundate” Anzu’s territories.

(6) The Contest between Ninurta and Anzu

What son can resist the impassioned pleas of his own mother? Ninurta certainly cannot, especially since in the context of the whole pentheonic council it is obviously backed with force. So, Ninurta and Anzu meet:

On the mountainside Anzu and Ninurta met...
(Anzu’s) mantle of radiance covered the mountain...

...
Anzu listened to (Ninurta’s) speech,
Then hurled his shout furiously amid the mountains.
Darkness fell over (?) the mountain, their faces were overcast.
Shamash, the light of the gods, was overcast by darkness

....
A clash between battle arrays was imminent, the flood-weapon massed.

....
Clouds of death rained down, an arrow flashed lightning,
Whizzed, the battle force roared between them.
The powerful, superb one, Mami’s son,

....
Set the shaft to the bow, drew it taut,
Aimed (?) the shaft at him from the bow’s curve. [425](#)

Before proceeding further, it is important to note how this passage, if read with the equation “mountains equal planets equal pyramids” in mind, yields a some very interesting insights. On this view, the “face” of the mountain on which the combatants are met could be either the “face” of a pyramid, or the surface of a planet, or both. Ninurta raises his “divine arrow,” his plasma thunderbolt, ready to strike. If mountain is here viewed in the “planetary” sense, then once again enormous discharges are ready to “arc” from one planetary “god” to another.

But then, suddenly, nothing happens:

But it (the arrow) did not go near Anzu: *the shaft turned back.*

Anzu shouted at it,

“You, shaft that came: return to your reed thicket!

Bow frame: back to your copse!

Bow string: Back to the ram’s gut! Feathers, return to the birds!”⁴²⁶

For readers of my *Giza Death Star* trilogy, and as we have also seen from Part One of this work, this is a clear signature of the type of “time-reversed,” scalar longitudinal waves being reflected back on their target. The arrow shaft of Ninurta, Ninurta’s “divine thunderbolt” far from reaching its intended target, bounced back to its origin! The explanation for this feat immediately follows in the text, and it’s a breather:

(Anzu) was holding the gods’ Tablet of Destinies in his hand.

And they influenced (?) the string of the bow; the arrows did not come near his body.

Deadly silence came over the battle, and conflict ceased.

Weapons stopped and did not capture Anzu amid the mountains. ⁴²⁷

Anzu, who had taken the Tablet of Destinies and fled to the “Inaccessible Mountain” had not only turned Ninurta’s divine thunderbolt back on itself, but had simply rendered all Ninurta’s arsenal useless. He had, so to speak, simply turned *off* Ninurta’s war machine. There are only two ways to interpret this passage in a non-catastrophist sense: either the effect was entirely *magical*, or it was entirely *technological*. And if the latter, it is a clear signature of the use of *scalar* weaponry on Anzu’s part, the signature of a phase conjugate mirror.

This should give one pause, for if this is so then the equation “mountain equals planets equals pyramids” means that Anzu has taken the Tablet of Destiny and hid it and himself in an “Inaccessible Mountain/Planet/Pyramid.” The war is both planetary and pyramidal in nature and scope.⁴²⁸

In the face of this devastating debacle, the pantheonic council again deliberates and decides that the only thing one can do in the face of this qualitative and technological superiority of firepower on Anzu’s part is to not “let the battle slacken’ with a view to ”tire him out.”⁴²⁹

This strategy of attrition does the trick, but only at a new cost:

Ninurta slew the mountains, inundated their proud pastures;
Inundated the broad earth in his fury,
Inundated the midst of the mountains, slew wicked Anzu.
*And marrior Ninurta regained the gods' Tablet of Destinies
for his own hand.* [430](#)

Thus the Tablets of Destinies, the original *causus belli*, were *not* returned to Enlil, but kept by Ninurta for himself, in usurpation upon usurpation!

Ninurta with his "Thunderbolts", from a Sculpture in the Palace of Assyrian King Asburnasirpal, ca. 800 BC

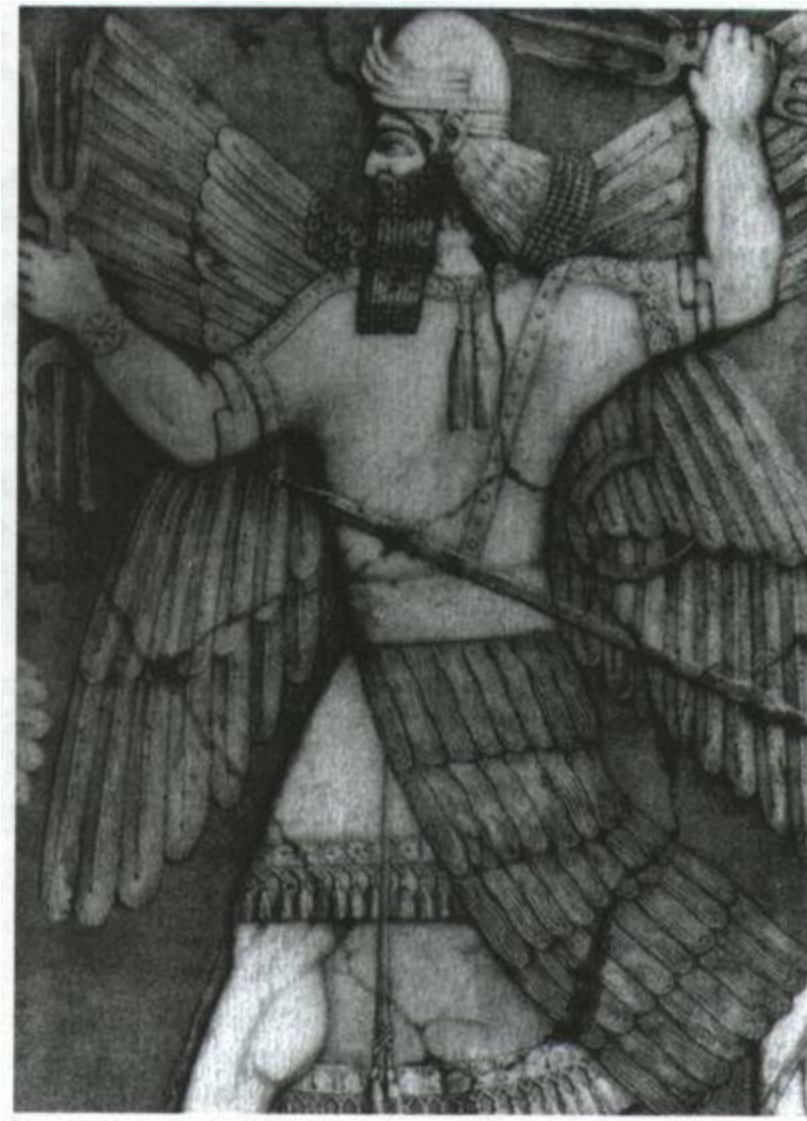

But this is not the end of the story.

It seems that Ninurta had difficulty in relinquishing the ME to the pantheon after he had retrieved them from Zu. Their vulnerability in the temple of Enlil was recognized and it was

decided to store them under the watchful eyes of Enki....in the Abzu...

There is a myth directly related to the battle between Zu and Ninurta and the events after that struggle. *Ninurta's Pride and Punishment* has been reconstructed from fragments found at Ur and Nippur. It tells what happened after Zu handed the ME over to Ninurta.

....Ninurta...laments the loss of the ME which he had possessed briefly, with the awesome power that went with them. As the story continues, Ninurta makes a trip to the Abzu where he is greeted joyously by Enki (who) praises him as the victor over the "bird" (Anzu) and as an unrivaled hero whose name will be duly honored by all.

This blessing, however, does not satisfy the ambitious Ninurta. As the myth states, "*On the whole universe the hero Ninurta set his sights,*" or in other words, *he coveted the ME and their power.* Ninurta demanded that Enki release the power stones to him.⁴³¹

That is, the ME were some sort of technology that allowed one to tap into the "power of the universe." What was this all-powerful "ME", what were these enigmatic and mysterious Tablets of Destinies? The answer to this all important question must wait until the next chapter. For now we must remain focused on the total context necessary to answer this most important question.

B. The Immediate Aftermath: The Technological Inventory

But exactly what happened to the ME after the defeat of Anzu by Ninurta?

As I indicated in the first book of my *Giza Death Star Trilogy*, *The Giza Death Star*, the victors in the struggle led by Ninurta perform an inventory of the vanquished foe's technology, slating some of it for use elsewhere, and part of it for destruction.

Another ancient Mesopotamian legend, *The Exploits of Ninurta*, enumerates this inventory at great length, after a brief introduction outlining the familiar motivations of the war: to recapture the ME.

In this legend, having vanquished the "mountains" arrayed against him, Ninurta was reminded by Aruru, Enlil's elder sister, that he had not yet "fixed the destinies of the warriors that you have slain." An interesting comment then immediately follows in the text: "The Lord (Ninurta) then addressed the U stone. He defined (?) its typical behaviour. The Lord spoke to it in anger in the Land, Ninurta, son of Enlil cursed it."⁴³² In other words, it is clear from the text that the "warriors" referred to are none other than the "power stones" Ninurta seized from Anzu and coveted for his own. Then follows a lengthy inventory, where Ninurta "fixes the destinies" of each stone, or group of stones. In reading the following lengthy excerpt, it should be remembered that specific modern equivalents of the names of stones are the guesses of modern scholars.

"U stone (emery), since you rose against me in the Mountains, since you barred the way (2 mss. have instead: seized me) so as to detain me, since you swore to put me to death, since you frightened me, Lord Ninurta, on my great throne; you are powerful, a youth of outstanding strength: may your size be diminished. A mighty lion, confident in its strength, will tear you into pieces, the strong man will fling you in his hand in combat (1 ms. Has instead: for strength). Young u stone, your brothers will heap you up like flour. You will lift your hand against your offspring, sink your teeth into their corpses. You, young man, though you may cry out, will end as Like a great wild bull killed by many people, be divided into portions. U Stone, you will be hounded from the battlefield with clubs, like a dog chased by shepherd boys. Because I am the Lord: since cornelian is polished by you, you shall be called by its name. And now, according to the destiny fixed by Ninurta, henceforth when u stone touches it, there will be pierced cornelian."

The Hero addressed the cu and gasura stones. The Lord enumerated their characteristics Ninurta son of Enlil fixed their destiny:

"Cu stones, since you attacked against my weapons; gasura stones, since you stood fiercely against me like bulls, since you tossed (?) your horns in the dust at me like wild bulls, you shall be..... like butterflies. My terrifying splendour will cover you. Since you cannot escape from my (1 ms has instead: his) great strength, the goldsmith shall puff and blow on you with his breath. You shall be shaped by him to form a matrix for his creations. People shall place the first fruits of the gods on you at the time of the new moon.

My King stood before the sajkal stone, he addressed the gulgul and sajjar stones. Ninurta son of Enlil fixed their destiny:

“*Sajkal stone, since you flew up against me.....; gulgul stone, since you sparked lightning against me.....; sajjar stone, since you shook your head at me, since you ground your teeth at me, the Lord! The sajjal stone will smash you, sajjar stone, young brave, and the gulgul stone will destroy(gul) you. You will be discarded as contemptible and valueless (saj nukala). Be a prey to the famine (Cagir) of the Land; you shall be fed by the charity of your city. You shall be accounted a common person, a warrior among slave-girls. They shall say to you, ‘Be off with you, hurry!’, it shall be your name. And now, by the destiny fixed by Ninurta, henceforth you shall be called a bad lot in the Land. So be it.*”

My King stood before the esi stone..... he spoke in hymnic language. Ninurta son of Enlil fixed its destiny:

“*Esi(diorite), your army in battle changed sides separately(?). You spread before me like thick smoke. You did not raise your hand. You did not attack me. Since you said, ‘It is false. The Lord is alone the Hero. Who can vie with Ninurta, son of Enlil?’ — they shall extract you from the highland countries. They shall bring(?) you from the land of Magan. You shall shape (?) Strong Copper like leather and then you shall be perfectly adapted for my heroic arm, for me, the Lord. When a king who is establishing his renown for perpetuity has had its statues sculpted for all time, you shall be placed in the place of libations - and it shall suit you well- in my temple, E-ninnu, the house full of grace. ”*

My King turned to the na stone. He..... the body from the na stone. Ninurta son of Enlil cursed it:

“*Stone, since you said, ‘If only it had been me’; na stones, since you bewitched my powers — like down there, you, to be worked on like a pig. Be discarded, be used for nothing, end up by being reduced to tiny fragments. He who knows you shall reduce you to liquid.’*

My King turned to the elal stone. Ninurta son of Enlil fixed its destiny:

“*Elal, intelligently you caused terror of me to descend on the Mountains where discord had broken out. In the rebel lands you proclaimed my name among my people who had banded together. Nothing of your wholeness shall be diminished (?). It shall be difficult to reduce your mass to small pieces. My divine ordinances shall be set out in straight lines on your body. You shall be greatly suited to the clash of weapons, when I have heroes to slay. You shall be set up on a pedestal in my great courtyard. The Land shall praise you in wonder, the foreign lands shall speak your praises (2 mss. have instead: elevate you).”*

The Hero turned to the kagina (haematite) stone, he addressed it for its hardness. Ninurta son of Enlil fixed its destiny: “*Young man worthy of respect, whose surface reflects the light, kagina, when the demands of the rebel lands reached you, I did not conquer you..... I did not notice you among the hostile ones. I shall make room for you in the Land. The divine rites of Utu shall become your powers. Be constituted as a judge in the foreign lands. The craftsmen, expert in everything, shall value you as if gold. Young man of whom I have taken possession, because of you I shall not sleep until you come to life. And now, according to the destiny fixed by Ninurta, henceforth kagina shall live! So shall it be.*”

The Hero stood before the jicnugal (alabaster) stone. Ninurta son of Enlil fixed its destiny: “*Icnu, whose body shines like the daylight! Purified silver, youth destined for the palace, since*

you alone held out your hands to me, and you prostrated yourself before me in your Mountains, I did not smite you with the club, and I did not turn my strength against you. Hero, you stood firm by me when I yelled out. Your name shall be called benevolence. The treasury of the Land shall be subject to your hand, you shall be its seal-keeper. (1 ms. adds the line: The Anuna.....)”

My King turned to the algamec stone and frowned. The Lord spoke to it angrily in the Land Ninurta son of Enlil cursed it: *“What provision did you make to assist my progress? Be the first to go into my forge. Algamec, you shall be the regular sacrifice offered daily by the smiths.”*

My King turned to the ducia stone. He addressed the nir, the gug (cornelian) and the zagin (lapis lazuli); the amac-pa-ed, the caba, the jurizum, the gug-gazi, and the marhali; the egi-saga, the girin-hiliba, the anzugulme and the nir-mucjir stones (1 ms.: the..... And the gazi-musud stones). The Lord Ninurta, son of Enlil, fixed their destinies for..... the waterskin: *“How you came to my side, male and female in form, and in your own way! You committed no fault, and you supported me with strength. You exalted me in public. Now in my deliberation, I shall exalt you. Since you made yourself general of the assembly, you, nir, shall be chosen for syrup and for wine. You shall all be decorated with precious metal. The principal among the gods shall cause the foreign lands to prostrate themselves before you, putting their noses to the ground.”*

My King turned to the jir-zu-jal (flint), and frowned. The Lord spoke to it angrily in the Land Ninurta son of Enlil cursed it: *“Ah, duplicitous jir-zu-jal, what then? They shall split your horns, wild bull, in your Mountains. Lie down before the..... You were not equal to me who supported you. I shall rip you like a sack, and people will smash you into tiny pieces. The metalworker shall deal with you, he shall use his chisel on you. Young man, massive, bearer of hatred: the carpenter, saying, ‘I wish to buy it for my work’, shall wet you with water..... and shall crush you like malt.”*

My King turned to the iman stones, he addressed the alliga stones. Ninurta son of Enlil fixed their destiny:

“Iman stones, in the Mountains you cried out against me. You fiercely uttered ballet-yells. I shall enflame you like fire. Like a storm I shall overturn you. I shall strip you like rushes. I shall rip you like weeds. Who will assist you then? Iman stone: your cries shall not be valued, no attention shall be paid to them. Iman stone, alliga stone: your path shall not lead to the palace.”

My King turned to the macda stone. He addressed the dubban and urutum stones. Ninurta son of Enlil defined (?) their characteristic behaviour:

“Macda stone, dubban stgone, blazing fires; urutum stone, which nothing resists; when the gasura stone..... and you were set ablaze, you burnt against me in the rebel lands like a brazier. Since you all stood against me in the land of Saba: macda stone, they shall slaughter you like a sheep. Dubban stone, they shall crunch you for pulverizing. Urutum stones, they shall sharpen you for the battle-mace; with bronze, the arrowheads of the gods, they shall smash you with the axe, stinging with fierce swords. ”

My King turned to the cagara stone. Ninurta son of Enlil fixed its destiny:

“Cagara stone, who smash (?) your head against anyone traveling alone in the desert, in the Mountains when my arms were occupied you tried to trample on me. Since you glutted yourself in the battle, the reed-worker shall make the reeds jump with you. You shall be thrown onto your couch; the appearance(?) of your mother and father who bore you shall be forgotten(?). No one shall say to you, ”Get up“, no one shall have the feeling that he misses you, the people shall not complain about your loss. In praise of the eternally-created powers in Ninursaja’s resting place, *you shall be discarded on the dais there*. They shall feed you on malt, as they do for sheep; you shall content yourself with a portion of the scattered flour. This shall be the explanation for you.”

My King turned to the marhuca stone, Ninurta the son of Enlil pronounced its destiny.

“Marhuca..... The string in my place, you were taken, since you did not participate in the crimes of your city,.....; *you shall be the bowl under the filter-jug, the water shall filter into you. Marhusa, you shall be used for inlay-work,* You shall be the perfect ornament for sacred brooches. Marhuca, you shall be duly praised in the temples of the gods.”

The Hero turned to the hactum stone and frowned. In the Land of the Lord addressed it angrily: Ninurta the son of Enlil pronounced its destiny:

“Hactum stone, *you cried out against me in the Mountains. You yelled fiercely with wild battle-yells. With your yelling, you fixed a lila demon in the Mountains*. Young man, because of your digging, Ditch (hactum) shall be your name. And now, according to the destiny of Ninurta, henceforth they shall say hactum. So be it.”

My King turned to the durul stone. Ninurta son of Enlil fixed its destiny:

“Durul stone, holy garment of mourning, blinded youth whom people carve, in the Mountains you prostrated yourself before me. Since you said to me, ‘If only it had been me who broke the bars of the gates, if only I had stood before him, before my King, Lord Ninurta’, your name shall be magnified of its own accord wherever it is mentioned. *As the connoisseur says of precious metal, I will buy it’, so the foreign nations, like musicians playing the reed-pipe, shall pursue you.* ”

My King turned to the cigcig stone, he addressed the engen and ezinum stones. For the ug-gun, the hem, the madanum, the sajgirmud, the and the mursuh stones, Ninurta son of Enlil fixed their destiny:

“(two lines unclear)... with ribs drawn in, balancing on the haunches, heart elated, legs bent like a bear,.....: I shall come to you; now, being an ally, you come forward from all of them; who shall extend the hand to them? You were the club, you stood as the doorway. (3 lines unclear) In the Land, the champion shall always look (?) with favour on you.”

The Hero turned to the kurgaranum stone. He addressed the bal stone; the Lord Ninurta, son of Enlil, fixed the destiny for the yellow-coloured cimbi (kohl):

“Since you said, ‘I will bring forth the people’, (1 line unclear) you.....as if.....the young man who has obtained (?) glory for you; the young artisan shall sing your praises. You shall be favoured for the festival of spirits of the dead; on the ninth day of the month, at the new moon, the young men shall..... for you.”

He assigned them to the cult of Ninhursaja.

The Hero had conquered the Mountains. As he moved across the desert, he.....[433](#)

While there are obviously numerous elements here that are clearly of a purely mythological nature, and consequently make it difficult to interpret in any meaningful or conclusive “paleophysical” way, there are other elements — the elements I have emphasized — that positively invite such an interpretation.

Among the latter is the basic fact that one does have here an *inventory* being made for the express purpose of the disposition of the technology that the stones embody and represent. The whole lengthy process is dimly evocative of the behavior of the western Allies after World War One and Two toward their former enemy, Germany. Some of the defeated side’s technologies were confiscated by the victors and carted off, to be used, or modified and then used in different applications, elsewhere. Other technologies were simply forbidden to be developed by the vanquished. And a few especially threatening technologies and weapons were simply smashed up and destroyed.

The principle by which Ninurta makes his determinations and “fixes the destinies” of the power stones is a simple one, devolving into two basic classes: (1) those which were directly deployed against him, or from which he experienced grave personal danger to his life or power or the power of the “gods,” were destroyed; and (2) those that were not so deployed or which constituted no direct threat in and of themselves, were preserved, and often removed and used elsewhere. As will be seen, there are also two special cases.

1. Stones to be Preserved and Adapted to Other Use

There are forty-one named stones in the text that are preserved and used elsewhere. These are the Cu, Gasura, Esi, Kagina, Jicnugal, Ducia, Nin, Gug, Zagin, Amal-Pa-Ed, Laba, Jurizum, Gug-gaz, Marhali, Egi-saga, Girin-Hihiilba, Anzugulme, Nir-muckir, Gazi-musud, Marhuca, Hactum, Durul, Cigcig, Engen, Ezinum, Ug-gun, Hem, Madanum, Sajgirmud, Mursum, Kurgaranum, Bac, and Ciml stones. Given that there are some breaks in the text, the possibility that other stones, whose names are now lost to history, cannot be discounted.

Many on this list — the Ducia, Nin, Gug, Zagin, Amal-Pa-Ed, Laba, Jurizum, Gug-gazi, Marhal, Egi-saga, Girin-Hihiilba, Anzugulme, Nir-muckir, Gazi-musud Stones - were to be preserved and apparently used for ornamental and ceremonial purposes, since Ninurta decreed that they were to be “decorated with precious metal” and that “foreign lands” would prostrate themselves before them.

In the case of the “Kagina Stone,” whose “surface reflects the light,” Ninurta decrees an odd fate. It would, he said, be used “as a judge in foreign lands,” and that it therefore should “live.” A similar destiny for use in official functions awaited the “Jicnugal Stone,” yet another stone connected with luminous brilliance, for its “body (shone) like the daylight.” Ninurta, as has been seen, decreed that it would be the “seal-keeper” of “the treasury of the land,” perhaps indicating that it played some special security function in guarding a place of wealth.

a. The “Cu Stones,” “Gasura Stones,” and “Hactum Stone”

But three stones in this list are worthy of some special attention, for unlike the others, they appeared to have been more directly components of a weapon of some sort, but they, unlike the other stones in this category, were preserved.

The “Cu Stone” was credited by Ninurta to have “attacked against my weapons.” The “Gasura Stone” is similarly accused of having “stood fiercely against me like bulls” and of “having tossed your horns in the dust at me like wild bulls.” These stones therefore had a clear weapons application. Ninurta, as has been seen, decrees that his own “terrifying splendour will cover” the stones and that they would be shaped by a “goldsmith” to “form a matrix for his creations.”

The “Cu” and “Gasura” Stones were thus to be subjected to intense heat, and molded or adapted to some other use, in spite of their original application as weapons.

The “Hactum Stone” was also clearly a weapon, having “cried out” against Ninurta from its place “in the Mountains.” Additional clues are given in the text that it “yelled fiercely with wild battle yells,” indicating that it was possibly a component in a weapon of an acoustical nature.⁴³⁴ Like the “Cu” and “Gasura” Stones, however, the “Hactum” Stone is apparently preserved, for Ninurta enigmatically states “Because of your digging, ditch shall be your name.” Apparently it was preserved because it was easily adaptable to uses that were not necessarily military, but which used its destructive potential in other practical ways.

Finally, the fate of the “Durul” Stone should be mentioned, for as the text indicates, it was a sought commodity of “connoisseurs” of precious metals. Ninurta thus decrees that “foreign nations shall pursue you,” suggesting that it was removed and sold.

2. Stones to be Destroyed

In addition to some special cases to be noted in the next section, there are stones that are obviously weapons and that could not be adapted to other uses. These were destroyed by various means.

a. The “Sajkal, Gulgul, and Sajjar” Stones

The “Sajkal” Stone is accused by Ninurta as having “flown up against me.” The “Sajjar” Stone “shook (its) head” and “ground (its) teeth” against Ninurta. But the most interesting and suggestive property of any of the stones is that associated with the “Gulgul” Stone,” which Ninurta states had “sparked lightning against me,” that is, it was capable of producing enormous electrostatic displays and somehow utilizing the same as a weapon, as was seen in chapter two.⁴³⁵

These three stones share a common and complex fate. Ninurta decrees that the “Sajjar” stone would be smashed and pulverized by the “Sajkal” stone and that the “Gulgul” stone would also be a part in its destruction. All three would then be “discarded as contemptible and valueless.” This would perhaps imply that there was some functional relationship between the three stones to begin with, and that a certain order had to be followed in the sequence of their destruction. Alternatively it might imply that the only things capable of destroying the “Sajjar” Stone was the “Sajkal” and “Gulgul” stones, and that all three stones are difficult to destroy.

b. The “U” Stone

The “U” Stone has earned Ninurta’s hostility by being the stone that “barred the way” (or, alternately, “seized me”) so as “to detain me.” Ninurta orders that its size “be diminished” and that a “mighty lion” should tear it to pieces. In other words, its size is somehow related to its power, and accordingly its size is to be “reduced” by breaking up the stone. The “U” Stone thus inhabits an ambiguous destiny, either being altogether destroyed, or merely broken up and preserved in other smaller forms.

The “Na” Stone appears to be similar in its functions, for it suffers a similar fate after having defied Ninurta and “bewitching (his) powers.” In one of the more colorful metaphors found in the various “destinies of the Stones,” Ninurta orders that it be “worked on like a pig,” be “used for nothing,” and both “reduced to tiny fragments,” *and* “reduced ... liquid.” The stone, on other words, appears to have been pulverized, liquefied, and then “discarded,” whatever terrifying powers it once enabled were to be poured out like water on the desert.

Of the “Algame” Stone not much is said. Ninurta notes it made no provision “to assist my progress,” and states simply that it should “be the first to go into my forge,” implying that it was melted down and destroyed, or perhaps adapted or molded for some other purpose.

The “Jir-Zu-Jal” Stone, noted for “duplicity” in the text, shares a similar fate. It is “ripped... like a sack” and smashed into “tiny pieces.”

Finally, the “Iman” and “Alliga” Stones are said by Ninurta to have “cried out against me” from within “the Mountains,” and of having “fiercly uttered bullet yells,” suggesting once again the primacy of acoustical phenomena to whatever weapon was deployed against Ninurta. To these, Ninurta decrees that he “shall enflame you like fire, like a storm I shall overturn you....I shall rip you like weeds.” These stones, too, in other words, were broken up and destroyed.

3. *Special Cases*

a. The “Cagara” Stone

The first special case is that of the “Cagara Stone.” Though it occurs later in the text than that of the second special case, it is treated first here because it would seem to be of lesser importance than that of the “Elel Stone” which preceded it. The “Cagara Stone” is accused of smashing its head “against anyone traveling in the desert.” Like the other stones, it was located “in the Mountains” where, when Ninurta was otherwise occupied, it had “tried to trample on me.” Ninurta’s decision concerning its “destiny” is somewhat peculiar, for he “discards it on the dais” of Ninhursag’s “resting place.”

What does one make of this? Clearly it departs from the pattern associated with the other stones that had been used against Ninurta, yet, it is preserved, although apparently hidden. This may be because it simply could not be destroyed without great difficulty. This possibility brings us to the second special case.

b. The “Elel” Stone

An even more special case is represented by the “Elel stone”. Let us recall Ninurta’s opening words: “Elel, intelligently you caused terror of me to descend on the Mountains where discord had broken out. In the rebel lands you proclaimed my name among my people who had banded together.” Thus far, the Elel Stone sounds like many others that were not used against Ninurta, and hence, its eventual preservation would seem to be motivated by that fact. But not so, if one reads carefully what later follows: “Nothing of your wholeness shall be diminished (?). It shall be difficult to reduce your mass to small pieces....You shall be greatly suited to the clash of weapons, when I have heroes to slay. You shall be set up on a pedestal in my great courtyard.” In other words, the “Elel Stone,” whatever it was, was difficult if not impossible to destroy, and its application as a weapon was clear and obvious to Ninurta. Hence, rather than letting it remain in its “Mountain,” pyramidal home, Ninurta removes it. It is safe to say that it was essential to the “Mountain’s” functioning as a weapon. Given what has been speculated and argued previously, that some scalar weaponry was involved in the destruction of the missing planet(s), the “Elel Stone” would appear to be a crucial component of this technology. Hence — and this is quite the crucial point — the “Elel Stone” was lost to history, secreted somewhere, *and may, like the “Cagara Stone” therefore still exist.* If the Sumerian origins of the text are any clue, then it may still exist in Iraq, buried beneath the shifting sands of the ages.⁴³⁶

C. *The Immediate Legacy: Conclusions*

What emerges from this examination is rather chilling, for it will be apparent that the “Story of the Stones” and Ninurta’s inventorying activity parallels another, though less ancient, myth: the Fall of Lucifer and the removal of the *lapis exili*, The “Stone of Exile” from his crown.

There is, however, a significant difference. Not only is there a clear indication that the function of many of the specifically weaponized stones is “*acoustic*” in nature, in keeping with a possible weapon based on scalar physics, but there is also an indication that two of these stones in particular were so powerful and impervious to destruction that they could only be removed and hidden, thus allowing the possibility that, while lost, they may still exist, and exist somewhere on the earth at that.

Equally important is the fact that the text seems to confirm our equation in a previous chapter that not only associates “Mountains” with “planets” in the formulary of catastrophists, but with the *e-kurs* of the Sumerians, the man-made mountains of the Pyramids and Ziggurats. Thus, if

Mountains \approx Planets \approx Pyramids,

then it is clear that an inventory is not only being taken of objects inside a pyramid, but it is equally clear that the best known example of a Pyramid from which there is clear evidence that something has been removed is the Great Pyramid.

This equation thus casts Zechariah Sitchin’s “Pyramid Wars” in a whole new light and context, for now, far from being events set merely on earth, the planetary component of the equation would indicate that these wars were cosmic in their scale, ferocity, and significance.

Clearly, if the inventory of the power stones that forms the bulk of the *Exploits of Ninurta* are identified with the Tablet(s) of Destinies stolen initially by Tiamat and later by Anzu, as there is evident reason to believe, then by the same token, it is also evident that at least *some* of this awesomely destructive technology survived the last known war for their possession.

And the clear association of these “stones of power” with the “ekurs” or artificial mountains of the pyramids and ziggurats would suggest where one with sufficient money and technology might look to find them again.

But exactly *what* were the original Tablets of Destinies? And why fight such a cosmically destructive war over, and *with*, them?

THE ENIGMA OF THE TABLETS: WHAT WERE THE “TABLETS OF DESTINIES”?

*“The ME ... has no equivalent in English and no translator has thus far been able to provide a satisfactory explanation of the term... Traditionally, scholars translate the term as ‘divine powers’ or ‘tablets of destiny’ for want of a better descriptive term.”*⁴³⁷

R. A. Boulay.

The question that now inevitably occurs is what exactly were these “stones of power”? What exactly were the “Tablets of Destiny” or, following Dalley’s translation, “Tablet of Destinies”, or following Sitchin’s translation, “Tablets of Destinies”? This enigma, in any of its variants, is one of the central riddles to be solved for anyone taking the war scenario of the ancient texts at their word. After all, if a war were fought to possess or to regain them because they conferred “the power of the universe” then obviously their possession conferred tremendous power to their owner. Merely to assert *that* they were a primary cause of this war is not enough, one must understand *why* they were a cause of that war, and to understand *why* they were, one must understand *what* they were, with as much precision and exactitude as possible.

From the previous chapter it would seem obvious that Zu’s theft of the Tablets from Enlil challenged the latter’s hegemony. It would seem equally apparent that they were somehow used by Zu in his war against Ninurta, that is, it would seem that the Tablets of Destinies either were weapons of awesome power, or that they could be used as such. And finally, it would appear that Ninurta’s inventory of the “stones” after the recovery of the Tablets of Destinies is somehow related, i.e., the inventoried stones may be components of the Tablets of Destinies. But this really does not advance us much further toward solving the riddle of these enigmatic “stones of power.” And this situation is not aided by the fact that in some instances it appears that the Tablets of Destinies could be used for communications.

Part of the enigma lies in the fact that the term “Tablets of Destinies” itself is an uncertain translation, an academic convention that has become accepted merely through widespread use. R.A. Boulay points out the difficulty few mainstream Assyriologists are willing to admit: no one knows exactly what they were, and the translation of the word “me” (pronounced like the month May) as “stone” or “tablet” is simply at best an educated guess:

The story of (An)Zu must have had a strong impact on the minds of ancient peoples for it concerned a struggle for power within the pantheon itself. It actually concerns the theft of the ME or “power stones” from the possession of the chief god Enlil and their recovery by his champion, the god Ninurta. The ME ... has no equivalent in English and no translator has thus far

been able to provide a satisfactory explanation of the term. It seemed to apply to anything composed of system, direction, ordered events, law, arts and crafts, even weapons and mechanical devices.

Traditionally, scholars translate the term as “divine powers” or “tablets of destiny” for want of a better descriptive term. But these names are grossly deficient, for in reality they were physical objects that could be carried about and upon which was engraved or transcribed instructions and standards of behavior. In this sense they seemed to be like our modern day computer storage disks and chips. The ME were actually the how-to-manuals of the ancients but embedded in “stone.”

Each ME provided the possessor full authority and power over a certain aspect of life, perhaps by providing essential information and instructions on controlling certain physical equipment. In this respect they may have been control modules use to operate certain pieces of equipment. Some of the ME were called ME-GAL-GAL or “great ME” and were associate with “divine” weapons of mass destruction.⁴³⁸

In yet another combination, MELAM or ME-LAM, meaning “brilliant ME,” the term suggests that the ME “were light-emitting crystals,”⁴³⁹ a significant clue, as we shall see.

Putting all these indications together, one may outline a preliminary answer to the riddle of what the ME or “power stones” or “Tablets of Destinies” were:

1. They were, first of all, *information* or objects *containing* information, that allowed one to tap into “the power of the universe;”
2. They were objects of *technology* that in use or conjunction with the “ekurs” or “mountains of stone” - the ziggurats and pyramids of the ancient world - allowed one to *access* that power, and thus wield a global hegemony by virtue of being able to manipulate that power *in a variety of ways*;
3. In the myths previously examined, these ME are almost always understood to be weapons. Their theft from Enlil by Anzu (or, earlier, by Tiamat!) thus implies something quite important about the civilization of the ancient “gods,” and that is, that the whole idea of “kingship” resided in the implicit ability and threat to make use of this force.
4. As was also seen in the previous chapter, the greatest of the MEs, the “Tablets of Destinies,” appear to be able to effect action at a distance.
5. Some MEs are also referred to as ME-LAM, or light emitting, suggesting a connection between the Tablets of Destinies and light, or electromagnetic radiation. This interpretation is supported by the fact that the texts indicate that after their theft, “radiance” disappeared.
6. And finally, it will be noted that these particular MEs, from their first theft by Tiamat to their their subsequent theft by Anzu, and their brief (?) period in the possession of Ninurta, exercises a peculiarly corrupting moral influence on their possessors, gradually sapping their will and consuming them with the obsessive desire to control and possess them. The MEs are like the “Ring” in J.R.R. Tolkien’s *Lord of the Rings* that gradually consume and corrupt the will of their possessors with their godlike powers both for destruction and for communication. They

were, for Tiamat, Kingu, and even Marduk himself, then Enlil, Zu, and Ninurta, and presumably others, as they were for Tolkien's character Gollum, their "precious."

But having said even all of this, we have merely rephrased what was known all along about them. We are still no nearer a solution to the riddle; we have merely outlined its complexity.

Clearly a more systematic approach is needed, one that pieces together a plausible picture of what the Tablets of Destinies were from the twin tracks of myth and of physics; the interdisciplinary approach of what I have termed "paleophysics" is tailor-made to answer precisely such questions. One might even say it is tailor-made to answer this specific question.

A. The Mythological Components and The Possessors of The Tablets

1. *Tiamat and Marduk*

The entry into the solution of the riddle lies first in the *possessors* of the Tablets of Destinies. The reason why is simple: the possessors of the Tablets are the least ambiguous concepts in the whole textual and conceptual complex surrounding the mysterious objects. The texts are clear about who possessed them, and more or less clear about the order of their successive owners. These two things - the *possessors* and the *order of the possessors* - afford the key that will begin to unlock the riddle.

The first “illegal” owner of the Tablets, who had stolen them, is of course, Tiamat. It will be recalled that the *Enuma Elish* indicates she gave them at some point to Kingu, one of her allies in her revolt and war. As we noted in our interpretation of that epic, Tiamat begins to use weather weapons in her war against her enemies, the clear implication being that the mysterious Tablets gave her the power to manipulate weather.

Now recall the “unified intention of symbol” for a moment, and remember that Tiamat is a *multi-leveled symbol* operating on several different levels simultaneously. At the most prosaic level, we have argued that she is a real person of some sort, and the name “Tiamat” itself may be a titular usage for the ruler or even a succession of rulers of a particular “region”, a particular *planet*. We also saw that the name Tiamat can function as a symbol of the Milky Way. Finally, we recall that her name may also mean “primordial waters,” or “the ocean of the deep.” And following the paleophysical paradigm, this “primordial deep” or “ocean” in turn functions as a symbol of a transmutative aether or medium, of the *materia prima*. And it should be noted, we learn these things about her *after* her theft of the Tablets of Destiny. Thus, it seems reasonable to conclude that her possession of them in some sense conferred upon her the ability to influence all these things. Once again, to paraphrase the *Lugal-e*, they conferred upon her “the power of the universe.”

Thus, the complex matrix of conceptual levels of meaning associated with “Tiamat” are the following:

1. Personal Ruler or succession of rulers (of);
2. A Planet;
3. The “Deep” or “Primeval Waters,” understood as the transmutative medium or *material prima*; and,
4. The Milky Way galaxy.

As the *Enuma Elish* relates, however, Tiamat is destroyed by Marduk. And not surprisingly, Marduk has his own multi-leveled set of associations. The Sumerologist Stephanie Dalley informs us that the name “Marduk” may mean “bull-calf of the Sun.”⁴⁴⁰ Marduk, like his Egyptian “cousin” Aten-Ra and his Hindu cousin Rama is a “sun god.” But De Santillana and Von Dechind also point out that Marduk is associated with the planet Jupiter.⁴⁴¹ Like Tiamat then, Marduk in the *Enuma Elish* is not only a personal ruler, but is also associated with a planet and also a star, i.e., with massive bodies.

According to the *Enuma Elish*, after his defeat of Tiamat, Marduk then (re-)measured the “structure

of the Deep.” In other words, the implication is that Marduk recovered the Tablets of Destinies, and with their assistance “measured the structure of the Deep”, an operation that was necessary since Tiamat, the exploded planet, was no longer in the picture, and the local celestial mechanics and geometry had changed drastically. With this, the structure of the Deep, of that transmutative medium or *materia prima* in local space, had been altered, and hence its new geometrical characteristics had to be ascertained anew. The Tablets of Destinies thus appear to give Marduk the power to do just that. *Thus, the Tablets have some intimate connection to the geometries of space and time of the local system.*

Thus, one has a similar if not identical list of meanings or levels associated with Marduk, or over which Marduk has “kingship” or power. Marduk is a

1. Personal Ruler, or succession of rulers (over);
2. The Sun
3. A planet
4. The “deep,” or transmutative aether.

The situation changes somewhat, though, with the next series of owners and possessors of the Tablets of Destinies: Enlil, Zu, and Ninurta.

2. Enlil, Zu, and Ninurta

Presumably the Tablets of Destinies were passed on from Marduk to Enlil. Here, of course, things took another turn for the worse, as the Tablets were stolen again, this time by Zu. Ninurta, Enlil's son, was sent to lead the effort to recover them, and another terrible war ensues, ending in the defeat and execution of Zu, Ninurta's recovery of the Tablets and his Inventory of the Stones. As was seen in the previous chapter, however, a new association has entered the picture, and this is the relationship:

Mountains \approx planets \approx gods \approx pyramids(or "ekurs").

While in possession of the Tablets, Zu waged a war with Ninurta similar in its ferocity and the types of weapons - some implying weather weapons - as was used by Tiamat after *her* theft of the Tablets. And this likewise implies once again that their possession conveyed the "kingship" or power over those things. So, Zu is

1. A Personal Ruler or succession of rulers (over)
2. A "mountain", which is associated with
3. A planet, which is now also associated with
4. A pyramid, or "ekur".

The obvious association of the last item with *stones* should not be overlooked.

Similarly, Ninurta after his victory and the recovery of the Tablets, performs his now celebrated "inventory of the stones," in which he destroys some and preserves others. But let us recall the strange connections of Ninurta, and the *associations* that those connections bring to the light. Stephanie Dalley states that Ninurta was not only a warrior God, but was "probably pronounced Nimrod."⁴⁴² As such, Ninurta is associated with that famous "tower that reaches to the heavens," an allusion clearly associating him with a pyramid.⁴⁴³ This tower, we learn from Genesis, was of concern because it would enable mankind to do whatever it had a mind to do. Its power, in other words, was "universal," and hence God took the decision to destroy it and to confound mankind's language. Let us recall that for the Mesopotamians, this "ekur" or tower, or pyramid, was the DU-AN-KI, the "bond heaven-earth," coupling the earth to the heavens and vice versa. This strange reference would seem to associate the DU-AN-KI with the Tower of Babel, and both in turn to the only structure in that region to clearly embody both celestial and terrestrial geometries in its dimensions: the Great Pyramid.⁴⁴⁴

B. A Summary Thus Far

At this juncture, it is worth pausing once again to summarize the clues assembled thus far. By sifting the evidence from the texts carefully, we know that the Tablets of Destinies

1. Convey universal power, or the power of the universe, to their possessors;
2. Were associated with electromagnetic energy, since they are referred to as ME-LAMs, or light emitting crystals, and their theft causes “radiance” to depart;
3. Were associated with Marduk’s re-measuring of “the structure of the deep” after his defeat of Tiamat, that is, they are associated with the geometry of local space and the celestial bodies in it, since a new Zodiac system is emplaced by Marduk, replacing that used by Tiamat;
4. Were associated with the DU-AN-KI or “Bond heaven-earth,” and with the Tower of Babel;
5. Conferred the power to manipulate weather.

But there are other clues to be considered.

C. *The Mythological Component and the Meaning of “Destinies” in “The Tablets of Destinies”*

One of the most significant clues as to what the Tablets of Destinies were may lie in the second term of the phrase used to describe them, “Destinies.” This term strongly suggests some connection to the pervasive role that astrology played in the ancient Mesopotamian cultures. The movements of the stars and planets, after all, were the movements of the “gods” themselves, decreeing the fates or “destinies” of things on earth below. But where does this belief come from, and why? No one really knows, but the famed Egyptologist E.A. Wallis Budge does provide a significant clue in his books *Amulets and Superstitions*, a study of ancient Middle Eastern magical artifacts.

The Sumerians and Babylonians believed that the will of the gods in respect to man and his affairs could be learned by watching the motions of the stars and planets, and that skilled stargazers could obtain from the motions of and varying aspects of the heavenly bodies indications of future prosperity and calamity. They therefore caused observations to be made and *recorded on tablets*, which they interpreted from a magical and not astronomical point of view, and these observations and their comments on them, and interpretations of them, have formed the foundation of the astrology in use in the world for the last 5,000 years. *According to ancient traditions preserved by Greek writers, the Babylonians made these observations for some hundreds of thousands of years, and though we must reject such fabulous statements, we are bound to believe that the period during which observations of the heavens were made on the plains of Babylonia comprised many thousands of years.*⁴⁴⁵

It is the pervasive habit of recording these astrological observations, and the sheer amount of such tablets, that surely led Assyriologists and translators to translate the term “Me” and “Me Gal Gal” as “Tablets of Destinies.” And their educated guess, as will be seen in this chapter, was much more appropriate than they might have cared to know!

But notice something else that Budge brings to our attention: there is a tradition in the cultures of the Middle East that these observations extend back to a period of time hundreds of thousands of years before the advent of Sumer and Egypt themselves! The Sumerian and Babylonian astrological sciences, in other words, were a *legacy*, and a *declined* legacy at that, of something far older, and as we shall see, something far more sophisticated.

This last point may be more fully understood by asking a very obvious question: *Why* was astrology such a pervasive “scientific” presence in almost all the great cultures of antiquity - Sumer, Egypt, Greece, the Vedic and Hindu, the Chinese, the Mayan, the Aztec, the Incan? Mainstream and even alternative scholars have labored over this question for decades, and have come to essentially the same conclusion: the ancients observed the motions of the heavens, were occasionally victims of some sort of celestial catastrophe, needed to know when to plant and harvest their crops, and so on, and felt awe and religious reverence for these tremendous powers that clothed, fed, and sometimes destroyed them, and embodied it all in the astrological lore we know today. De Santillana and Von Dechend’s classic study *Hamlet’s Mill* is perhaps the prime example of this line of thinking, but there

are many, many others. One is left, in other words, with a well-footnoted reassertion of the old paradigm that the ancients were primitive and superstitious peoples and that this sort of thing is just the sort of thing that they did. The standard line is that one need not look further into the possibility that their knowledge is a residue of an actual *science* left over, misunderstood - or understood as best as they could - by the cultures that were legacies of an incomparably more sophisticated civilization. According to that standard school of interpretation, therefore, one must not take those civilizations' own assertions that they are the legacies of that much older, much more ancient, and much more sophisticated culture at their word.

But Budge presents information - tantalizing information - that something more must have been going on. He notes that the Babylonian zodiac in use throughout Babylon was "set up by Marduk' *after* his defeat of Tiamat, and that its signs "were different from the old ones, which he had disbanded..."⁴⁴⁶ Indeed, Budge even produces the *previous* zodiac in use by Tiamat, Kingu and their associates prior to the war that destroyed her.⁴⁴⁷ In other words, in addition to the *Enuma Elish's* statement that after the war and the explosion of the Planet Tiamat, Marduk "measured the structure of the deep," there was also the introduction of a new zodiac, which is precisely a new "measure of the structure of the deep."

So we may draw our first tentative answer, our first *clue*, to unraveling the enigma of what exactly the Tablets of Destinies were: *They concerned "astrological" information, written or transcribed on "tablets."* But since we know the consistent belief of astrology is that the positions and motions of the stars have subtle influences on life, emotions, and consciousness, we must add that this information was somehow included in whatever the Tablets of Destinies were.

So far, so good.

1. *The Astrological Association of Certain Stones with Celestial Bodies*

But there is more to this ancient astrological lore, according to Budge, than this, and here is where it begins to get very interesting. Most modern people only encounter astrology, if they encounter it at all, in the “horoscope” page of the local newspaper, or in little booklets of sun signs in the grocery store aisle. Because of this type of exposure, most people think of astrology as having only to do with the subtle influences of the stars and planets on human life. But there is most decidedly more to the ancient view, as Budge observes:

The old astrologers believed that precious and semi-precious stones were bearers of the influences of the Seven Astrological Stars or Planets. Thus they associated with the-

SUN, yellowish or gold-coloured stones, e.g. amber, hyacinth, topaz, chrysolite.

With the MOON, whitish stones, e.g. the diamond, crystal, opal, beryl, mother-of-pearl.

With MARS, red stones, e.g. ruby, haematite, jasper, blood-stone.

With MERCURY, stones of neutral tints, e.g. agate, carnelian, chalcedony, sardonyx.

With JUPITER, blue stones, e.g. amethyst, turquoise, sapphire, jasper, blue diamond.

With VENUS, green stones, e.g. the emerald and some kinds of sapphires.

With SATURN, black stones, e.g. jet, onyx, obsidian, diamond, and black coral.⁴⁴⁸

But what is this, this new association of crystalline *stones* with the *stars* (the Sun) and with *planets*? And more importantly, where did it come from? *Why is it there?* Almost no one seems to know, but the implication of Budge’s remarks are clear: *this too is a component of that astrological lore that dates back into that tradition of “hundreds of thousands of years” of observation.*

It is, in other words, part of the “sciences of the ‘gods.’” Recall the association of similar stones with the war between Ninurta and Zu, his careful inventory of Zu’s “stones” after his victory, his relegation of some of them to destruction, others to other uses, and some - a very few - which could not be destroyed nor adapted, were simply secreted away in temples to be used in rites, and presumably never heard from again. Recall too the association of the “stone of exile,” the “jewel” in Lucifer’s crown, which he lost when he fell. And of course, recall the most obvious thing: the whole cosmic war in both its phases, the struggle between Tiamat and Marduk, the later struggle between Ninurta and Zu, was a war for the possession and control of stones, of the “Tablets of Destinies.”

We now observe another obvious thing: Ninurta’s “Inventory of the Stones” as recorded in the *Lugal-E* occurs when he has defeated Anzu, and since the whole war was caused by the latter’s theft of the “Tablets of Destinies”, we conclude that *Ninurta’s inventory was an inventory of the “stones” or components that constituted the Tablets of Destinies.* We now have another clue to answering what exactly these Tablets of Destinies were, and why they conferred such tremendous powers to their possessors, power that, if one recalls our examination of the texts in the two previous chapters, was an almost “universal” power, i.e., conferred the power of the universe - of the stars and

planets, and indeed the galaxy (recalling the “galactic context” of De Santillana and Von Dechind) - on their possessors. In this respect, De Santillana and Von Dechind record a very peculiar fact about Marduk’s war with Tiamat: two of the stars of the constellation Scorpio were some of his *weapons*.[449](#)

If one now recalls the association of particular types of “stones” with certain celestial bodies that is a signal part of this ancient astrological lore, then one might draw the conclusion that “stones” could be “weapons” when connected with such celestial bodies as Marduk’s “star weapons”. This conclusion seems warranted by the very fact of Ninurta’s “Inventory of the Stones,” which, as we have learned, was an inventory of the recovered components of the Tablets of Destinies, which conferred “the power of the universe.”

2. *The Tablets of Destinies Jam the Talk of the Galaxy*

Anzu's theft of the Tablets of Destinies from Enlil brought forth a most unusual complaint, which I cite here from the Old Babylonian version:

(Anzu) stole the Ellil-power; rites were abandoned,
Father Ellil their counselor was dumbstruck.

*Radiance faded (?), silence reigned...*⁴⁵⁰

Zechariah Sitchin observes that "In Sumerian the name ZU meant 'He Who Knows,' one expert in certain knowledge. Several references to the evil hero of this tale as AN.ZU - 'He Who Knows the Heavens' - suggest" for Sitchin a disruption in communications between the gods on Earth and elsewhere in the universe.⁴⁵¹ Sitchin, of course, maintains that the theft of the Tablets shut down communications between a "spaceport" from which rockets maintained a steady traffic between Earth and the gods' "homeworld," Nibiru. While this is not the place to delve into the particulars of Sitchin's "paleophysical" interpretations, needless to say, I do not subscribe to this particular detail of Sitchin's scenario for the simple reason that mere rockets would be a far too slow and inefficient method for any practical travel between worlds.

But his observation here is nonetheless an intriguing and important one for two crucial reasons. The first is that (An)Zu's *actions* give him the characteristic of a rebel and warrior, while his *name* gives him characteristics similar to Egypt's wisdom-god, Thoth. The second important point about Sitchin's observation is that *the theft of the Tablets of Destinies breaks down communications between Earth and "Elsewhere."*

3. *Thoth's Tablets Once Again*

Ninurta's "Inventory of the Stones" and the Tablets of Destinies, viewed in this total "astro-mythological context," begins to sound peculiarly familiar, for it implies that his "Inventory" was nothing less than a lithographic record of a vast body of knowledge, encompassing celestial geometry, the properties of celestial bodies, and the mutual influences that existed between them and particular stones. They are, in one sense, summaries of *information*.

And in this respect, they begin to sound like the Tablets of another well-known Middle Eastern god, the Egyptian god of wisdom, Thoth. Here, I quote from pages 58 - 62 of my book *The Giza Death Star Destroyed* once again, this time in order to show the similarities between Thoth and Ninurta, and more importantly, between *The Book of Thoth* and Ninurta's Tablets of Destinies:

"a. The Role of Hermes-Thoth in the Founding of Esotericism

"Scattered throughout (Manly) Hall's *Secret Teachings of All Ages* are numerous references to the enigmatic figure of Hermes-Thoth, and his crucial role in the post-diluvian founding of esotericism. Aside from his identifications with Enoch and other figures in various traditions,⁴⁵² the figure of Hermes-Thoth is "of first importance to Masonic scholars, because he was the author of the Masonic initiatory rituals, which were borrowed from the Mysteries established by Hermes."⁴⁵³ This connection of Hermes-Thoth with ante-diluvian knowledge and its survival in Masonic traditions is made even more apparent by the identification of Thoth with the figure of Hiram Abiff, a figure who plays such a central role in the death-resurrection rituals of the first three degrees of Masonry.⁴⁵⁴ This tradition ascribes the identification to the so-called *Emerald Tablet of Thoth*, about which we shall have more to say in a moment. More important for the subject of esoteric continuity are the numerous references to the survival of Hermes-Thoth's knowledge in the forms of books or inscribed tablets. In some versions, forty-two volumes of his works were removed from the Library of Alexandria prior to its burning, and secreted with "initiates" who buried them in the desert for safekeeping.⁴⁵⁵

"Returning now to the subject of the *Emerald Tablet of Thoth*, another strand of esoteric tradition concerns the so-called *Sacred Book of Thoth*, a work we have referred in the two previous *Giza Death Star* books.⁴⁵⁶ Esoteric tradition has it that while Thoth-Hermes "still walked the earth with men, he entrusted to his chosen successors the sacred *Book of Thoth*. This work contained the secret processes by which the regeneration of humanity was to be accomplished and also served as the key to his other writings."⁴⁵⁷ The theme of this book was most likely the connection between the cosmos and man, a key made manifest by the law of analogy:

The ancients believed that the theory of man's being made in the image of God was to be understood literally. They maintained that the universe was a great organism not unlike the human body, and that *every phase and function of the Universal Body had a correspondence in man*.⁴⁵⁸ The most precious Key to Wisdom that the priests communicated to the new initiates

was what they termed the *law of analogy*.⁴⁵⁹

Here I will interrupt my quotation of *The Giza Death Star Destroyed* to note that one aspect of ancient belief was precisely the idea that that “subtle influences” and correspondences existed between the universe and the human individual, a variation on the astrological theme. Returning now to the extended quotation from that book:

“This principle (of analogy) formed the basis of my interpretation of ancient Hermetic and Vedic texts in *The Giza Death Star*⁴⁶⁰ and ... is a central methodology informing the work of revisionist Egyptologist and scholar R. A. Schwaller De Lubicz.

“In any case, not much is known about the alleged *Book of Thoth* other than that its “pages” were apparently covered with hieroglyphics and other symbols that allegedly gave its possessors “*unlimited power over the spirits of the air and subterranean divinities*”⁴⁶¹

“That is to say, the *Book of Thoth* was, for the esoteric tradition, a book of high magic. That it might have been a book of high science is possible, if one understand the “spirits of the air and subterranean divinities” to mean the principles of celestial and terrestrial mechanics and physics.

And once again I interrupt my quotation to observe that Thoth’s mysterious book of “magic”, like the Mesopotamian “Tablets of Destinies” conferred a kind of universal power to its possessor. Continuing now with the quotation:

“But there is another significance to the *Book of Thoth*:

According to legend, the *Book of Thoth* was kept in a golden box in the inner sanctuary of the temple. There was but one key and this was in the possession of the “Master of the Mysteries,” the highest initiate of the Hermetic Arcanum. He alone knew what was written in the secret book. The *Book of Thoth* was lost to the ancient world with the decay of the Mysteries, but its faithful initiates carried it sealed in the sacred casket into another land. The book is still in existence and continues to lead the disciples of this age into the presence of the Immortals. No other information can be given to the world concerning it now, but the apostolic succession from the first hierophant initiated by Hermes himself remains unbroken to this day, and those who are peculiarly fitted to serve the Immortals may discover this priceless document if they will search sincerely and tirelessly for it.⁴⁶²

“While Hall gives no reference for these assertions, it is significant that, for our purposes, this book of lost knowledge constitutes a center piece in the notion that the esoteric tradition is *continuous* from the time of the Flood....

“It will be recalled that according to some traditions, this book was inscribed on sapphire. Similar traditions in Judaism record that the first giving of the tablets of the Law to Moses were also inscribed on sapphire. And in some cases, the *Book of Thoth* was said to be deposited in an “ark” like box. The *Zohar* records that God originally fashioned the tablets of the Law from a “divine

sapphire, *Schethiya*, which the Most High, after removing from His own throne, had cast into the Abyss to become the foundation and generator of the worlds.⁴⁶³ This recalls the association of sapphire with the enigmatic properties of gravity, recorded in *The Giza Death Star*, for apparently this crystalline structure is capable of detection of very small quantum gravitational fluctuations.⁴⁶⁴

“But there is another association of sapphire in the esoteric tradition, and for our purposes, this association is quite significant. This is the “Stone of Exile” or *Lapis Exilis*, the “crown jewel of the Archangel Lucifer.”⁴⁶⁵ This version of the legend has it that the Archangel Michael struck the jewel from Lucifer’s crown, whence it fell into the Abyss.

I then outlined a lengthy series of relationships, but highlight the two that concern us here, for they are signally important:

- “The tentative identification of the Sphinx with Lord Nergal, Babylonian god of Mars, Fire, and War;
- ”The association of Giza, and in particular, the Great Pyramid, with Hermes-Thoth;
- ***“The further association of Thoth with a tablet or book of lost knowledge of physical mechanics of a comprehensive nature, inscribed on emerald or sapphire***
- “The association of Lucifer with similar crystals;
- “The association of both Lucifer and Nergal with wars of *rebellion*;⁴⁶⁶
- “The interplanetary war between “Tiamat” and “Marduk” caused by Tiamat’s possession, or usurpation, of the “Tablet” or “Stone(s) of Destiny”;
- “The missing resonator assemblies in the Grand Gallery of the Great Pyramid, which were according to Sitchin’s reconstruction of the Babylonian epic Lugal-e, of crystalline nature;
- ***“The association of this lost and crystalline Book of Thoth with the notion of the continuity of the esoteric tradition.***

This way of viewing things tends to support the notion, so cherished in Freemasonry and other modern secret societies, that embedded within such esoteric traditions is an occulted science, and that at least one element of the lost paleoancient Very High Civilization deliberately occulted such science for the eventual resurrection and recovery of the technologies it made possible.

“Thoth’s tablets are also associated with one more thing, and that is alchemy.⁴⁶⁷ Alchemy is, of course, the “science” of the transmutation of “base elements” into “gold”. From the “paleophysics” perspective adopted here, this too might be understood as the residue of a *real* lost science dealing with the physics of a “hydro-dynamic” transmutative aether or physical substrate.⁴⁶⁸

Summing up what we have learned, we now have the following highly suggestive catalogue of properties of the Tablets of Destinies:

Clue Number 1:

The Tablets of Destinies were “stones” or stone-like material, each of which was associated with some celestial body, and with some subtle influence between those bodies and their possessors.

We will call this the **“Stones \approx Celestial Body Association.”** This association is evidenced by (1) Ninurta’s “Inventory of the Stone” of the Tablets of Destiny after their recovery from Zu at the end of their war; and by (2) the long association of stones with celestial bodies in ancient astrological lore. We posit, therefore, an underlying *purely scientific and “paleophysical”* basis for these associations that, by the time of the classical Mesopotamian civilizations, has declined to the interplanetary sympathetic magic of astrological lore.

This “Stones \approx Celestial Body Association” is also related to the doctrine of astrology that celestial bodies have a subtle influence on human lives, and the whole ancient practice of sympathetic magic with its talismans and amulets is an indicator that a reciprocal influence is also possible, that the latter can also influence the former.

Clue Number 2:

The Tablets of Destinies also contained information on the underlying physical medium or substrate itself, and how to manipulate it, presumably in connection to the “Stones \approx Celestial Bodies Association” of clue number one above. They confer the power of the universe to their possessors.

Both Thoth’s *Book of Magic* and/or his celebrated *Emerald Tablet*, and the Mesopotamian Tablets of Destinies are also associated with the idea that they convey “universal power” to their possessors. That is, they convey power *over* the universe by conveying the power *of* the universe to their possessors. In the case of Thoth’s Tablets we saw that their strong alchemical association might be interpreted as the residue of a long lost science of the *power of the transmutative aether, or physical medium or substrate itself*. The Tablets are, then, a kind of physical version of the Akashic Records of esoteric lore, since the Tablets appear to record how to effect the information content in the field of that medium or substrate.

We shall call this the **“Transmutative Medium \approx Akashic Records \approx Universal Power Association.”**

Clue Number 3:

Per Sitchin, the Tablets of Destinies were involved in interplanetary and interstellar communication of some sort.

Their theft by Anzu therefore not only conferred to him tremendous power, but also cut off or interfered with the communications of his opponents. We shall call this the **“Commmunications Association.”**

And finally,

Clue Number 4:

The Tablets of Destinies appear to have been “activated” only in physical proximity to their possessors.

This point is related to the alchemical connection of Thoth’s Tablets, and to the general ancient doctrine that the Universe was somehow a “makanthropos,” a large scale version of mankind. Thus, there were subtle influences between the gods, mankind, and even between individuals, and the celestial bodies of the universe. This is further born out by curious statement from the *Myth of (An)Zu* that Ninurta “regained the gods’ Tablet of Destinies for his own hand.”⁴⁶⁹ The Tablets may thus have contained the original actual science behind the ancient doctrine of man as “makanthropos”⁴⁷⁰ as well as that behind the ancient belief in the celestial influences of astrology.

We shall call this most mysterious and enigmatic property of the Tablets of Destinies the “**Subtle Influences Association.**”

A table will perhaps best summarize what is known of them from the mythological side, and what the evidence is for each point:

Table of Tablets of Destinies Associations

<i>Association</i>	<i>Supporting Mythological Conceptual Complex</i>
Stones ≈ Celestial Body Association	<ol style="list-style-type: none">1. Zodiacal lore association precious and semi-precious gems with celestial bodies2. Relationship of Ninurta’s Inventory of the Stones with Tablets of Destinies
Transmutative Medium ≈ Akashic Records ≈ Universal Power Association	<ol style="list-style-type: none">1. <i>Book of Thoth</i>2. Thoth’s <i>Emerald Tablets</i>3. References in various Mesopotamian myths that describe the Tablets as containing information, or “laws” or “Mes” conveying the power of the universe.
Communications Association	<ol style="list-style-type: none">1. Sitchin’s interpretation that the theft of the Tablets interfered with or cut off Enlil’s and his associates’ ability to communicate with “Elsewhere”
Subtle Influences Association	<ol style="list-style-type: none">1. The general mythological context of the universe as a “makanthropos,”2. The references in some texts that the Tablets appear to be activated in close physical proximity or actual context with their possessors, as with Ninurta’s acquiring them for “his own hand.”

This table of the “Clues” and their supporting associations indicates both why so many interpreters - who *do* sense some underlying “paleophysical” and technological basis for the Tablets of Destinies - come up with such a wide variety of explanations, for viewing only one or two of the Associations, the answer will be incomplete. It is only in the *total* context of all four “Clues” or “Associations” viewed against the background of the points in our summaries in this chapter, that a more thorough — though still speculative — answer may be obtained, as we shall now see.

C. The Quantum Potential or Scalar Physics Basis of the Four Associations of the Tablets of Destinies

The careful reader will have noticed that each of the four associations or clues of what the Tablets of Destinies were has an exact analogue in the various physical theories and phenomena surveyed in part one. Accordingly, we shall follow each of the four associations into the realm of physics, and assemble a complete hypothetical edifice at the end of this section corresponding with the table above.

1. *The Physics of the “Stones ≈ Celestial Body” Association: Paul LaViolette’s Stars As Galactic Communications Devices*

At the risk of being redundant, let us now recall verbatim from chapter five what scientist Paul LaViolette wrote about the possibility that pulsars could be, or have been, used in a vast galactic system of interstellar communication with a physical frame of reference centered upon our own solar system. LaViolette’s series of crucial observations, as we noted there, would become “signally important in answering one of the most enduring questions of mythology from a paleophysical point of view,” and the question to be answered was “What exactly are the Tablets of Destinies”? LaViolette wrote

Optical phase conjugation is most commonly known for its use in military laser weapons systems for destroying enemy missiles. In this application, a laser beam is *directed at a distant moving missile target and light rays scattered back from the target are allowed to enter the phase conjugator, a chamber containing a medium having nonlinear optical properties. In this nonlinear medium, the scattered rays interact with two opposed laser beams of similar wavelength to form a hologram-like electrostatic light refracting pattern called a “grating.” Once this grating pattern is formed, the system has essentially locked onto its target. A powerful laser weapon is then discharged into this holographic grating pattern, whereupon the coherent laser light reflects (from the grating) in such a way as to produce an intense outgoing laser beam that retraces the paths that had been followed by the incoming rays that had originally been scattered from the missile. Consequently, the outgoing laser pulse converges precisely back onto its missile target.* [471](#)

I then commented in chapter five as follows:

Bearing in mind that plasma is one such “nonlinear medium,” we may now see what optical phase conjugation is, and why it was used in the Star Wars program, both the modern one, *and the ancient one.* [472](#)

Phase conjugation is best understood by breaking down its components into steps or stages:

1. A coherent beam of electromagnetic energy is aimed at a target, which beam is reflected *back* to the transmitter.
2. The returning beam is then split in a non-linear medium and interfered in it, which creates the “grating”, or, as Lt. Col Tom Bearden would put it, a “template” for action. The reason that an interference pattern is created is that *the atmosphere distorted the returning or reflected beam, thus making it of slightly different frequency from the outgoing wave.*

And here an important comment is necessary. Vacuum space is also both a wave *propagating* and wave *distorting* medium, for as the rotating version of the famous Michelson-Morley experiment of French physicist Georges Sagnac demonstrated, a split beam of light fired in opposite directions in a rotating system and then interfered produces precisely such a grating or interference pattern, demonstrating a local effect of an “aether

drag.” But what would be the best way of detecting an interference grating for a target many millions of miles distant, where electromagnetic waves would have to travel to and back from an object through vacuum space? Here recall the rotating plasmas, or plasmoids of chapter two, and one has the answer: *the non-linear medium par excellence for forming a grating that results from reflecting a beam through the wave-distorting medium of spaces would be a quickly rotating plasma.* A further consequence of this view should also be noted, for this means that stars *are natural phase conjugate mirrors of local stellar-system spaces.* Once one has the concept of phase conjugation and the non-linear interference grating “capturing medium” of rotating plasma, one has the two essential ingredients for any such “scalar” weapon as LaViolette proposes.

3. Once this grid or interference pattern is created, the actual “punch” or energetic pulse of the weapon is fired *through the “holographical” grating* which then *reverses the effect of the intervening distorting medium, and thus the main punch arrives at its target perfectly cohered and in **perfect** resonance with its target, since the “grating” is the signature of that target and that target only.*

We now return to LaViolette, who proposes a “Mark II” version of phase conjugation, this time, not with cohered electromagnetic energy in the visible spectrum, but in the radio and microwave frequencies:

Consequently, it should be possible to phase conjugate microwaves by following techniques similar to those described in experiments with an optical phase conjugation. However, it appears that most of this research is still highly classified. While many papers have been published on optical phase conjugation, virtually no literature is available on the application of phase conjugation at microwave frequencies.⁴⁷³

And if LaViolette can propose microwave phase conjugation as a kind of Mark II, “power upgrade” of optical phase conjugation, it is not difficult to see that the next step, Mark III, would be *X-ray and gamma ray phase conjugation.*

At this juncture, having refreshed the reader’s memory with LaViolette’s “pulsar communicator system” and its interstellar, lethal potentialities, it is also worthwhile to recall that *stars formed one weapons system in Marduk’s arsenal, as De Santillana and Von Dechind observed.*

Let us also recall, at the risk of being redundant once again, the exact components that LaViolette envisioned for this vast interstellar communications and weapons system:

...suppose that a bank of high-voltage capacitors are suddenly discharged to momentarily create a powerful air ionizing arc, or regularly shaped plasmoid. Also, suppose that a beam of coherent microwave radiation from a maser is targeted on this plasmoid. This beam would be sent out by a phase conjugating device something like that pictured... This device splits the original maser beam into two beams, a *probe beam and a pump beam.* The probe beam is directed toward the plasma target, and some of its scattered microwaves shine back toward the phase conjugator device and enter its *mixer chamber.* The mixer chamber is filled with a medium that has very

nonlinear electromagnetic properties. Meanwhile, the pump beam that is split off from the maser generator is directed to the adjoining mixer chamber where it passes through the nonlinear mixer medium, reflects from a wall at the far end, makes a second pass back through the mixer medium, and then reenters the maser generator compartment.

The microwaves that scatter from the plasmoid and enter the mixer medium strongly interact with the two pump maser beams to form an electrostatic grating pattern. This holographic pattern stores information about the directions and phases of all the scattered maser beam microwaves that have entered the mixer. The counterpropagating pump beams then reflect from this grating pattern to produce an outgoing microwave beam that *precisely traces the paths followed by the incoming scattered waves... the randomizing effects of wave scattering having been automatically compensated for.* ...The grating that performs this time-reversed reflection is called a *phase conjugate mirror* and the mixing arrangement that allows all this to happen is termed a *four wave mixer*.This closed loop path from the maser beam generator, to the plasmoid, to the mixer, to the plasmoid, and back to the maser beam generator, causes the maser system to function as a *phase conjugate resonator* and to *preferentially select and amplify only those microwaves that target the phase conjugating mixer chamber.* As a result, most of the microwave power emitted from the maser will end up being confined to a beam that extends between the maser beam generator, the plasmoid target, and the mixer chamber. The energy bottled up in this beam will then progressively build up to a very high value.⁴⁷⁴

Thus, we may now see what possibly comprises one element of what the Tablets of Destinies were; *they were a catalogue of the grating or interference patterns of various celestial bodies for a phase conjugate mirror of great sophistication.* They were, to recall Bearden's remarks from chapter two, the *templates of action* for those mirrors.

3. The Physics of the “Transmutative Aether \approx Universal Power \approx Akashic Field” Association:

Bearden’s “Mark IV” Scalar Version of LaViolette’s Galactic Communicators, and Laszlo’s Akashic Field

As has been seen, La Violette’s speculations involve only standard electromagnetic phase conjugation, even though he himself proposes a microwave, “Mark II” version of normal “Mark I” optical phase conjugation.⁴⁷⁵ As I then observed in chapter five, this would seem to open up the possibility for a “Mark III” version of electromagnetic phase conjugation based on X-rays and or even deadlier gamma rays. Of course, there are engineering problems galore with such a notion. In my book *The SS Brotherhood of the Bell* I noted that one problem scientists faced, who were involved in the Pentagon’s so-called - and in the context of this book - aptly named “Star Wars” program, was how to cohere gamma rays like an optical laser beam. How would one construct the “optical” or “lasing cavity” for a gamma ray laser, or graser, since no known means seemed to be available to do it until the stressing-and-cohering properties of the Mossbauer Effect were discovered. This effect essentially means that a radioactive and gamma emitting source such as cobalt, under certain conditions of acoustic resonance and stress, can be induced or stimulated to emit beams of coherent gamma rays.⁴⁷⁶

A similar problem would be faced in constructing a beam-splitter for a gamma-ray based phase conjugate mirror, since no method is yet known how to split a graser-beam, much less to mix them to construct a “grating” through which the main graser beam would be pumped.

But once one recalls what Bearden’s scalar physics actually is - and as was seen in chapter five LaViolette is specifically aware of Bearden’s work and its potential - then one would have to posit a “Mark IV” version of a phase conjugate mirror, *one based on recording the gratings of the interfered longitudinal waves in the medium itself*. This version, like all other properly configured “Marks” in our series of phase conjugate mirrors, would be capable of action at a great distance without the constraints of the “relativistic speed limit” of the velocity of light.

In this context, The Tablets with their catalogue of interference patterns of longitudinal waves within the medium would constitute an object conferring a kind of universal power. Such a catalogue, with the medium acting as a kind of “akashic field” that, in the words of philosopher and scientist Ervin Laszlo, carries information “by super-imposed vacuum wave-interference patterns that are equivalent to holograms,”⁴⁷⁷ would be an object conferring almost godlike powers for communications over vast distances, and almost godlike powers of destruction. And it should be noted that *both* uses are modes of deployment of the *same* technology.

Laszlo’s reference to holograms in this context of action at a distance through what is essentially the non-local phenomenon of the medium throws light on the basic *technique* that would be used in such a Mark IV phase conjugate mirror. It is a technique already well-known and empirically demonstrated in the laboratory:

First two charged atoms (ions), labeled A and B, are “entangled,” creating the instance

link...Then a third atom, labeled P, is prepared by encoding in it the coherently superposed quantum state that is to be teleported. Then A, one of the entangled ions, is measured together with the prepared atom P. At that point the internal quantum state of B transforms: it assumes the exact state that was encoded in P! ...When A and P are measured together, the preexisting nonlocal connection between A and B creates a nonlocal transfer of state from P to B.⁴⁷⁸

Magnified to a universal scale, this means that “the quantum vacuum generates the holographic field that is the memory of the universe.”⁴⁷⁹

Such nonlocal transference of quantum states, it is now known, can be greatly extended to *whole interference patterns of torsion waves*:

A particularly promising theory is the work of the Russian physicists G.L. Shipov, A.E. Akimov, and coworkers, further elaborated by scientists in America as well as Europe. Their “torsion-wave” theory shows how the vacuum can link physical events throughout space-time. According to the Russian physicists, torsion waves link the universe at a group speed of the order of 10^9 c - one billion times the speed of light!

Torsion-wave linking⁴⁸⁰ may involve more than the known forms of energy: it may also involve *information*. It is standard knowledge that particles that have a quantum property known as “spin” also have a magnetic effect: they possess a specific magnetic momentum. The magnetic impulse is registered in the vacuum in the form of minute vortices... As the Hungarian theoretician Laszlo Gazdag has argued, these tiny vortices carry information, much as magnetic impulses do on a computer disk. The information carried by a given vortex corresponds to the magnetic momentum of the particle that created it: it is information on the state of that particle. *These minute spinning structures travel through the vacuum, and they interact with each other. When two or more of these torsion waves meet, they form an interference pattern that integrates the strands of information on the particles that created them. This interference pattern carries information on the entire ensembles of the particles....*

There is no evident limit to the information that interfering vacuum torsion waves can conserve and convey. In the final count, they can carry information on the state of the whole universe. Throughout the universe, particles are linked by the vacuum in much the same way as objects are linked in the sea: by making and receiving waves. ⁴⁸¹

The medium, therefore, carries universal information, namely, the information of the universe. It is worth citing Laszlo at length once again, for his insights bear directly on the Association of “Transmutative Aether \approx Universal Power \approx Akashic Field”:

Although much remains to be discovered about the quantum vacuum, it is already clear that it is a superdense cosmic medium. It carries light, and all the universal forces of nature. Pressure waves may propagate through it... This is the finding of the German mathematical physicist Hartmut Mueller,⁴⁸² who claims that *the observed dimensions of all entities, from atoms to galaxies, is determined by interaction with density-pressure waves propagating in the vacuum.*⁴⁸³

Consequently, “all the information that constitutes the universe is stored on its periphery, which is a two-dimensional surface.”⁴⁸⁴ Thus, the Tablets of Destinies are a catalogue of a certain limited set of this holographic information. Like all holograms, they are a grating or interference pattern, whose information is only revealed by shining a cohered energy beam of the frequency that created them through the grating. And we saw previously that the Tablets were also associated with ME-LAMs with “light emitting crystals.”

Thus, we may now see what comprises yet another element of what the Tablets of Destinies were; they were not only a catalogue of the grating or interference patterns of various celestial bodies for a phase conjugate mirror of great sophistication, but - since they are based on such interference waves in the medium itself - they are also a catalogue of those types of waves, giving their possessor limited access to the “memory of the universe” (to borrow Laszlo’s phrase), or to the “information content of the field” of the universe, and as such, conveying to their possessors both “universal” powers and the powers of “the universe.” In this sense, the “destinies” component of the term “Tablets of Destinies” is not so far from what actually may have been the case, signifying objects able to manipulate the local space and time, the “destinies”, of objects themselves.

There is one more implication of this component of the Tablets of Destinies that should be noticed, though extensive comment will have to be reserved to a later point in this chapter: Because such an interferometric grating of waves in the medium itself would give the Tablets’ possessor access to the “memory” of at least a large part of the galactic universe, it stands to reason that part of that “memory” comprises the memory, and therefore, *the character and intention*, of its possessors. Or to put it in a scalar physicist’s terms, *the memory, character, and intention of the possessor of the Tablets of Destinies functions like a local structured potential, and impresses these dynamics of their possessor upon the Tablets. These impressed dynamics become part of the catalogue of “gratings” that comprise the Tablets.*

3. The Physics of the “Communications Association”: Bearden’s Scalar Physics and Communications via Longitudinal Waves in the Medium, LaViolette’s Grating, and a Fearsome Interface

As scientist Paul LaViolette noted earlier, and as has been noted with the above quotations from Ervin Laszlo, scalar, longitudinal pressure waves - what I have repeatedly called “electro-acoustic” waves - in the medium might be the most effective way of communication over vast interstellar distances, since it would not be limited by the relativistic speed limit of the velocity of light. And as I noted above, there is a definite and important role of the conscious observer both in influencing, and in being influenced by, the “grating” of the interference of such waves.

Many commentators and physicists have observed that the phenomenon of Coordinate Remote Viewing seems to access this “information content of the field” or medium. One may therefore speculate that the Tablets of Destinies are not only catalogues of gratings in the senses of the two previous associations, but possibly also a mechanism or *interface* that would enhance such phenomena as coordinate remote viewing, or, as will be seen toward the end of this chapter, “channeling”.

Thus, we may now see what comprises yet another element of what the Tablets of Destinies were; they were not only a catalogue of the grating or interference patterns of various celestial bodies for a phase conjugate mirror of great sophistication. They are not only a catalogue of those types of waves, giving their possessor limited access to the “memory of the universe” (to borrow Laszlo’s phrase), or to the “information content of the field” of the universe, and as such, conveying to their possessors “universal” powers and the powers of “the universe.” They are also the “gratings” necessary to send information, to *communicate* over vast distances free of the constraints of the relativistic speed limit of light. And as also noted, the Tablets of Destinies are also perhaps a technology of interface between consciousness and the gratings themselves.

Laszlo’s remarks concerning the “holographic” nature of these phenomena, plus the implication that consciousness can impress its emotional, character, and intentional dynamics on these gratings and in *turn be impressed by them*, leads us finally to...

4.... *The Physics of the “Subtle Influence Association ”: Bearden on the Local Structured Potential and Psychoenergetics*

One aspect of scalar or quantum potential physics that Lt. Col. Tom Bearden spends a great deal of time on is the ability of his “templates” or “causal system robots” - which we have been calling “gratings” - to effect the induction of *disease* or, conversely, *healing* at a distance, by inducing the structured potential or “grating” or electromagnetic signature of particular diseases at a distance.⁴⁸⁵

But beyond the ability to effect states of disease or health in biological organisms, there is also a component, an implication, of this science of impressed dynamics and templates that is nothing less than chilling. It is best to cite Bearden’s own trenchant and succinct warning in this regard:

- When God created life and living systems He also created the process for making life and a living biological system.
- The process is still there and it exists as a process in and of this 4-spatial world.
- Once the process is discovered and modeled, technology can be developed to apply the process at will.
- So scientists can scientifically study the process and develop the technology to use it.
- (Scientists can thus) make a living mind and living biological system, and tailor it to form ***and whatever behavior is desired***.
- That superweapon science is called psychoenergetics⁴⁸⁶

Note then, that one implication of the “grating” or template is the ability to influence emotions, character, and behavior at a distance by constructing a “grating” or template, through which a beam is sent.

a. Impressed Emotional Dynamics: The Tablets of Destinies and the Spread of the “Virus” of Evil

As these thoughts aver, it is possible to impress certain character, emotional, and intentional dynamics on these gratings, and vice versa, it is possible, as the quotation from Bearden avers, for these gratings to induce, via “electro-acoustic” means, states of character, emotion, and behavior.

At this juncture it is crucial for the reader to recall what happened to the possessors of the Tablets of Destinies after their initial theft by Tiamat. From Tiamat, to Marduk, who recovered them from her, to Enlil, to Anzu, to Ninurta...each of their possessors engaged in horrific acts of warfare and wholesale destruction and slaughter. It is as if the evil acts and/or intentions of their initial possessor impressed itself on the Tablets, and in the case of their later possessors, that this latent impressed dynamic in turn may have influenced them.

So in addition to all the foregoing, the Tablets of Destinies may also be a catalogue of the templates of *the impressed dynamics of consciousness* of certain individuals. They are, so to speak, not a “virus” of evil, but what produces that virus.

b. A Return to the Edfu Texts

With these thoughts in mind, let us return to the Edfu texts and note some peculiar features. E.A.E. Reymond says that shortly after the creation of the Primeval mound was “connected also with uttering of names.” But these names are “names either of one or of several sacred places which were created” on the Primeval Mound.⁴⁸⁷

We saw in chapter seven how the process of creation in the Edfu texts is also connected with the recitation of “spells” over objects that represented the special places to be created. The presence of such objects in connection with sound and the process of creation, and now the evident use of “names” to denote specific locations, strongly suggests the type of scalar physics I believe to be operative in the Tablets of Destinies is also operative here in the Edfu texts. The parallels are quite remarkable. Indeed, Reymond states that the Edfu texts mention a “Sacred Book of the Temples.” It is certain that this book did not contain regulations of the temple ritual services or descriptions of the structural development of the Edfu Temple. *The part of this document preserved at Edfu reveals that it included lists of names of mythical shrines and sacred places; each name listed is accompanied with a brief explanation of the mythological significance implicit in that particular name.*⁴⁸⁸ In other words, the “Sound Eye” to which the Edfu texts refer may be one and the same as the technologies the Edfu texts recount elsewhere in relation to the creation of the primeval mound itself. The technology described corresponds with the basic components of scalar technology and weapons to a remarkable, and in my opinion, non-coincidental degree. In this case, the “naming” of places would correspond to the specific “gratings” for each location.

This conclusion is supported by an extensive comment Reymond makes elsewhere, and which we previously cited in chapter seven:

We attempted to explain in one of our previous studies the significance of the action described as ... *to endure with power the substances of the Earth*. It appeared as though this... action had the aspect of a symbolic and magical rite of creation. The main part of that rite consisted of uttering sacred spells by the creators over certain (objects) which, we may say, might have been believed to symbolize the Earth to be created. We suspect that by virtue of this rite it was believed that the symbols of the Earth were filled with special power. This power then caused the Earth to emerge in the form of specific plots of earth along and around the edges of the island. This process of creation of the Earth by the word of the creators has no equivalent. Such a manner of creation can be compared with the Hermopolitan conception of the creation of the world; according to the latter, the Earth was believed to have been created by drying up the primaevial waters that surrounded the island. Both of these ways of creating, the magical process as well as the procedure by the solar radiance, had the same result, they seem to have made manifest what was created previously by the nameless powers, but was hidden beneath the primaevial waters.⁴⁸⁹

As I observed in chapter seven, this gives us the following elements:

1. The Edfu accounts, by maintaining a creation by the utterance of “magic spells” is paralleling yet another famous account of a similar concept of creation, that of Genesis 1. Both maintain that *sound* is somehow involved;
2. These “spells” were, however, unlike the Genesis account, uttered *over* certain objects which then created the various “earths” desired;
3. If one adds in the Hermopolitan tradition, the use of (solar) radiation or energy is also a component.

So we have:

1. Sound
2. Objects
3. Energy, or radiation.

But now we also have a “book” describing the names of specific places, in other words, along with the above three items, the “book” of “sacred place names” constitutes the final essential element in this scalar technology. It is analogous to the “templates” or gratings discussed previously in respect to the Tablets of Destinies. In short, the Edfu texts indicate a similar if not identical technology that was associated with the “creation” and the subsequent conflict, and that these very same technologies describe the mythical “Sound Eye” that wrought such destruction during that conflict. It would thus appear that both the Mesopotamian “Tablets of Destinies” and the Edfu “Sound Eye” are two traditions that reflect a common and remote technological ancestor.

c. A Summary

We are now in a position to summarize the whole conceptual complex within mythology that surrounds the Tablets of Destinies by adding to our familiar formula. Here, however, we make one significant modification to it based on the findings of this chapter; here we replace the term “Planets” in the formula, with the term “Celestial Bodies:”

“Mountains” \approx “Celestial Bodies” \approx “Pyramids” \approx “Tablets”

As before, I define the symbol \approx to mean “are closely associated, but not identical, with.”

All the above relationships are summarized in the following table on the next page.

Table of Associations of the Tablets of Destinies

<i>Association</i>	<i>Supporting Mythological Conceptual Complex</i>	<i>Supporting Physics Conception</i>
Stones ~ Celestial Body Association	<ol style="list-style-type: none"> 1. Zodiacal lore association precious and semi-precious gems with celestial bodies 2. Relationship of Ninurta's Inventory of the Stones with Tablets of Destinies 	<ol style="list-style-type: none"> 1. LaViolette's Pulsar Communications and Weapons Systems, involving, 2. The gratings or templates of phase conjugate mirrors in versions Mark II and Mark III.
Transmutative Medium ~ Akashic Records ~ Universal Power Association	<ol style="list-style-type: none"> 1. <i>Book of Thoth</i> 2. Thoth's <i>Emerald Tablets</i> 3. References in various Mesopotamian myths that describe the Tablets as containing information, or "laws" or "Mes" conveying the power of the universe. 	<ol style="list-style-type: none"> 1. The view of the medium as a "field of memory or information", as a kind of "akashic field". 2. Impressed local dynamics of consciousness may be, and most likely are, involved.
Communications Association	<ol style="list-style-type: none"> 1. Sitchin's interpretation that the theft of the Tablets interfered with or cut off Enlil's and his associates' ability to communicate with "Elsewhere" 	<ol style="list-style-type: none"> 1. Bearden's, T.T. Brown's, and Tesla's longitudinal wave form in the medium as a communications system. 2. The phase conjugate mirror's grating may have a mechanism of interfacing with consciousness
Subtle Influences Association	<ol style="list-style-type: none"> 1. The general mythological context of the universe as a "makanthropos"; 2. The references in some texts that the Tablets appear to be activated in close physical proximity or actual context with their possessors, as with Ninurta's acquiring them for "his own hand." 	<ol style="list-style-type: none"> 1. Consciousness is also a local structured potential, and may impress its dynamics —and hence its character, emotions, and behavioral habits — on the grating, and vice versa. That is, it may be directly influenced by scalar interferometry.

We now have a rational basis upon which to speculate what the Tablets of Destinies were:

Grounded both in the ancient texts and a modern physics interpretation of them, the Tablets of Destinies were most likely crystals of some sort through which light or other electromagnetic energy was beamed, and these crystals contained information. This information was the "holographic" interferometric "grating" or "interference pattern", Bearden's quantum potential "template of action," the scalar signatures, of almost every celestial body considered important in, to, and by the civilization of the "gods." These priceless catalogues were, moreover, compiled relative to our own solar system as their physical frame of reference. Additionally, they included within their catalogue of "gratings" or "templates" the "subtle influences" — as an impressed dynamic — of consciousness.⁴⁹⁰ They most likely worked best, therefore, when interfaced — by means now lost and unknown to us — with an intelligent and conscious user. This catalogue of interferometric gratings, based on longitudinal waves in the medium, was thus the central component of any communications system that held together their vast and interstellar empire, since only the gratings themselves allowed one to select the system with which one wished to communicate. Similarly, these interferometric gratings were the central

components in any weapon system designed to target celestial bodies from a great distance. Finally, the catalogue which was the Tablets of Destinies also likely included numerous gratings or templates of emotional states, which could also be impressed into targets from a great distance.

If this speculative hypothesis concerning the Tablets of Destinies is true, then it constitutes an explanation that explains why their theft at various times

- Broke down communications between the solar system and other parts of their empire;*
- Caused the “gods” extreme concern that they would no longer be able to rule because of their lack of ability to continue to manipulate their subjects mentally and emotionally;*
- Conferred hegemony to whomever possessed them not only for the above reasons, but because they allowed the targeting of scalar weapons of mass destruction at great distance.*

In short, The Tablets of Destinies were the “software”⁴⁹¹ gratings of phase onjugate mirrors for almost every celestial body that was considered important to them, that held their empire together, and made their scalar- and “electro-acoustic”- based communications and weapons systems work.

As has been outlined here, one aspect of this paleophysics involves consciousness and mind manipulation by means of impressed electrodynamics on targeted biological systems and intelligent life. This is, perhaps, an enduring legacy of the war, for if as I have argued in the *Giza Death Star* trilogy, the Great Pyramid *was* a component in some ancient scalar weapons system of vast power, then its shell still stands at Giza, *perhaps maintaining some partial functioning of this nature.*

While it is highly speculative, it is nonetheless worth pointing out here that there might be a *technology* - a very *ancient* technology - that lies behind the phenomena of “channeled messages from ‘extraterrestrials’” and so on that have been with humanity throughout most of its history, down to, and including the modern obsession with them and with their dubious messages of coming “peace and enlightenment.” One researcher, with whom the present author has been privileged to share a stage during conferences, and whom the present author highly respects, seriously suggested that if the Great Pyramid was a weapon, then perhaps its usage was entirely benign, being one of beaming feelings of love, harmony, and peace, and thus preventing wars. Beyond the moral questions this raises about the interference with the individual will, it begs the obvious question of why that particular region seems throughout its history to be the home not only of “revelations” but of rivers of blood spilt in countless wars. Far from supporting such a contention, the bloody barrenness of the region would seem to argue against my friend’s speculation. Indeed, his speculation would not seem to be the best way of dodging the bullet that there might be a *malign* aspect and influence at work, one attested to time and again in the texts from that part of the world.

In this connection it is interesting to note that Thorkild Jacobsen’s translation of the *Lugal-e* refers to some of the stones as *warriors*, a theme that was clearly recognizable in the previous chapter, in Dalley’s translations of the same epic:

The Basalt, the Diorite, the Dolerite,
the “Duck”-stone, the Haematite,

and the warrior Alabaster, its warriors
constantly come raiding the cities,
for them a monster's tooth has grown up...⁴⁹²

While the “monster's tooth” could be a reference to a pyramid, a little further on the text states that “daily the Azag is turning the border (district) over to its side!”⁴⁹³ These references suggest that the Tablets were being used to manipulate the emotions of whole populations to take up arms in the revolt, and tend to confirm our hypothesis that consciousness was a primary component of the manipulation both of the Tablets by their possessors, and in turn of individuals by the Tablets.

So what happened to the Tablets of Destinies? As we already know, some of their components were destroyed by Ninurta. Others, as we also know, were adapted to other use, and some, which could not be destroyed, were, like Thoth's emerald tablets, secreted away. The truly sobering reality is not only *what* the Tablets of Destinies were, but that some of them, the most malign components in fact, may still exist.

A clue perhaps, if afforded by Marduk's own admission in the *Erra/Nergal and Ishum* text that he “changed the location of the *mesu*-tree (and of) the *elmesu*-stone, and did not reveal it to anyone.”⁴⁹⁴ If, as seems likely, these objects were components of the Tablets, then it would appear that some of them were deliberately hidden by Marduk long before their subsequent theft from Enlil by (An)Zu. A little later on in the same story, it appears that Nergal convinced Marduk to reveal to him the location of these objects:

He made his voice heard and spoke to prince Marduk

“[
[The holy *elmesu*-stone {
]]”⁴⁹⁵

⁴⁹⁵ The gap in the text suggests that this is what Nergal was up to, for a short while later, Nergal reveals his intentions to Marduk, who approves of his plan:

I shall make Anu and Ellil lie down like bulls, to right and left
of your gate.”

Prince Marduk listened to him,

And the speech that Erra (Nergal) made was pleasing to him.⁴⁹⁶

This gives us not only some insight into the genocidal characters of Nergal and Marduk, but a clue as to the possible whereabouts today of these missing components of the Tablets of Destinies.

Careful consideration of the details of this and the previous chapter will reveal that their possible locations are tied to a very few locations, far beneath the sands and rock of the deserts of Mesopotamia and Egypt: Giza, Babylon and Nimrud or Nippur - site of Ninurta's temple - in Iraq,⁴⁹⁷ and possibly Baalbek in Lebanon. But as we shall also discover, there is a certain body of evidence

that suggests that some of them also made their way... elsewhere.

But whatever their location, the texts and legends associated with them, from Thoth's Emerald Tablets to Ninurta's missing stones of power, all indicate that something of the original Tablets of Destiny survived.

**ME'S, MER'S, AND MARS: MORE WHO'S AND WHAT'S, AND (AT LAST)
SOME WHERE'S**

“There is nothing connected to the many supposed superstitious funerary rituals of Egypt that cannot also be interpreted as pertaining to space travel or some more advanced scientific accomplishment. ”

Bruce Rux[498](#)

A. *Introductory Remarks*

There are, according to alternative researcher Bruce Rux, essentially three ways to view the similarities in ancient myths from around the world:

One, each myth cycle is indigenous to a given people, beginning with features unique to them that then become influenced by invaders or assimilated tribes; two, myths are all psychological projections (called by Jung “archetypes”) of man’s innermost psyche, showing the universality of the human soul; or, three, they are all the same myth from great antiquity, becoming individually corrupted in various ways over the ensuing centuries. The first two theories are the prevailing ones today, being the anthropological and psychological schools of thought. The latter is generally dismissed without much consideration, since it brings to mind Atlantis (and other seemingly fabulous theories), which has become excluded from the accepted canon of theories though there is a tremendous amount of evidence to suggest it once existed.⁴⁹⁹

How else would one explain, for example, the myth among the Omaha Indians of North America of the burning cedar tree which was not consumed, and from which the animals had worn four trails, each of which led in one of the four cardinal compass points?⁵⁰⁰ The similarity to Moses’ theophany at the burning bush in Sinai is at least as remarkable as the differences between the two accounts.

And this “similar-dissimilar” pattern is one that can be encountered time and again when one examines the myths of the world. It is not the fact that there *are* such similarities that is so arresting, it is rather their sheer *quantity*, and the extent to which these similarities extend to details. But equally arresting are the *dissimilarities*. All too often one encounters in parallel myths not only the same details, but *new* ones, at times seemingly contradictory to what is assumed to be the “original” story.

So one must modify Rux’s “third alternative” method of explaining the commonalities of ancient myths to include the possibility that not all details of a mythological “archetype” will be included in any given culture’s retelling of a particular myth. Details might be missing in one account that might be preserved in another. And this makes any task of reconstructing the “original” myth that much more difficult. It is like trying to assemble a massive four-dimensional jigsaw puzzle, matching the edges of motifs from one account with those of another. The situation is rendered all the more complex given that so many of these myths evidence the same kind of “sacred punning” and multi-tiered layers of meaning that we have called the “Unified Intention of Symbol” in our encounters with the rich mythological traditions of Egypt and Mesopotamia. The details preserved in one account might be found in a completely different context in another account, and thus, one or the other, or both, might be garbled versions of the “original.” On any account, if the pursuit of the first two alternatives mentioned by Rux be viewed as a kind of “mythological liberalism” or Jungian “deconstruction,” then by the same token the third alternative is a kind of “mythological higher criticism” seeking to recover the lost originals from textual clues and external evidences.

But clues nonetheless there are, and ignoring them by the standard academic anesthetic of deconstruction, Jungian or otherwise, will not make them go away. They are still there, a throbbing and nagging symptom in our perceptions that the anesthetic has only dulled but not eradicated. It is

time then to allow the anesthetic to wear off and die of its own dead weight, and confront the headache head-on.

Perhaps the most painful aspect of this mythological migraine is the persistent, and *detailed* association of Egypt, Mesopotamia, and Mars. In *The Giza Death Star Destroyed* I speculated on a connection between the Red Planet and the Giza plateau by way of the curious correspondences that exist between the Mesopotamian god Nergal - god of Mars, fire, rebellion, and war - and the whole concept of a chimerical creature such as the Sphinx.^{[501](#)} But there are many, many more such peculiar connections...

B. MEs, MERs, and Mars

Bruce Rux, to whom we have already referred, points out that the word “mer”, meaning “place of ascension” is one term that ancient Egyptians gave to their pyramids, a meaning associating them, once again, with the heavens.⁵⁰² The same, Rux notes, can also be said of the Sumerian MEs, or power objects. But Rux adds one of those “details” referred to earlier. “The Sumerian Enoch’s name, ‘Enmeduranki,’” contains the root DUR-AN-KI, which as noted previously, means the “bond heaven earth,” and thus the Sumerian Enoch’s name “meant ‘Ruler whose Me connects Heaven and Earth.’”⁵⁰³ But this is not all. There are peculiar, and detailed, connections to the Red Planet, to Mars, and to the god of war who rules it. To see how, one must journey away from Mesopotamia and Egypt, out across the Atlantic, to North and South America and to some very intriguing native American Indian traditions.

1. Native American Indian Connections

One tale that concerns us is that of the Chiapas Indians of Guatemala, whose language, notes Rux “has always confused scholars because of its strong resemblance to Hebrew.”⁵⁰⁴ The Chiapas had a legend

about an exiled king come came to stay with them, a white man-god who lived among them, traveling frequently, teaching them civilization and all their knowledge. His name was “Votan,” and his people were called the *Chivim*, “Serpents.” Not only is the name quite obviously the same as that of “Wotan” (which, in the German tongue, would be exactly pronounced “Votan”) and “Odin,” but it also cannot help but call to mind the great god of the American Indian Creation epic, the *Chon-oopa-sa*, named “Wo-kon.” Votan told them the story of the Tower of Babel, as “*a great city where a magnificent temple was under construction which was intended to reach to heaven, but was doomed by a confusion of languages.*” He was associated with snakes, and with healing. Before his departure, he wrote a book in the Quiche language describing his travels and hidden treasures, which was burned by Bishop Nunez de la Vega in 1691.⁵⁰⁵

More will be said about the connection of this “civilizing god” with snakes at a subsequent point. Here what must command one’s attention is the fact that the Guatemalan version of the story is almost identical with that of the biblical, and yet no explanation exists for it! It is, nonetheless, *there*.

Consider the magnitude of the problem that this presents. On the standard theory of Indian migration from Asia to North America via a land bridge some tens of thousands of years ago, prior to all physical connection between the two great world islands being lost, the story could not possibly have come by this route, unless one posits that it took place much earlier than standard biblical histories will allow, or that communication between the two world islands was maintained by a high seafaring culture, which standard theory likewise discountenances to some extent, in spite of some considerable evidence that such was precisely the case.

The Tower of Babel, however, is not the only such case to be explained. In Australia, aboriginal peoples recount a legend of a sun god who comes down from heaven, and conquers the earth with “intense heat after a mighty and terrifying conflict.”⁵⁰⁶ This reference to a sun god, to a kind of heat-based weapon, and to an obvious war, resonates with the Egyptian sun-god Ra, and with his “eye” weapon, as we shall see in a moment. But how would Egyptian and Australian aboriginals recount almost the same war, in the same terms? “Jungian archetypes” might be able to explain the coincidences of “war legends” across various cultures, but it seems to stretch their explanatory power to assume that they explain the detailed similarities in weapons used and in the personages involved in wielding them.

2. More Connections: Giants, the Red-Paint People, and the Astronomical West

Egyptian, Irish-Celtic, and Gallic-Celtic legends refer to an enigmatic “Land of the West” which may well refer to the two American continents. The various Celtic and Germanic traditions also refer - as we saw in chapter three - to races of warlike giants, and even the Cherokee nation of North America refers to the *Tsunilkalu*, a “slant-eyed” race of giants” from a land in the west, and classical Greek references exist quoting Gallic stories about a “Hyperborean” land in the west which was invaded by warring giants from the Western Ocean.⁵⁰⁷

Another peculiar connection exists between the “New” world and the “Old” world of ancient Egypt: the “Red Paint People.” The Mayan god Pacal was depicted as a white man of - for then large stature, “whose teeth were discovered to be painted bright red.”⁵⁰⁸ It is this same figure of Pacal on his famous “sarcophagus” in Palenque, that many revisionists of the “ancient astronauts” school, beginning with Erich von Däniken in his famous *Chariots of the Gods*, take to be a stylized portrayal of an astronaut in a space capsule.

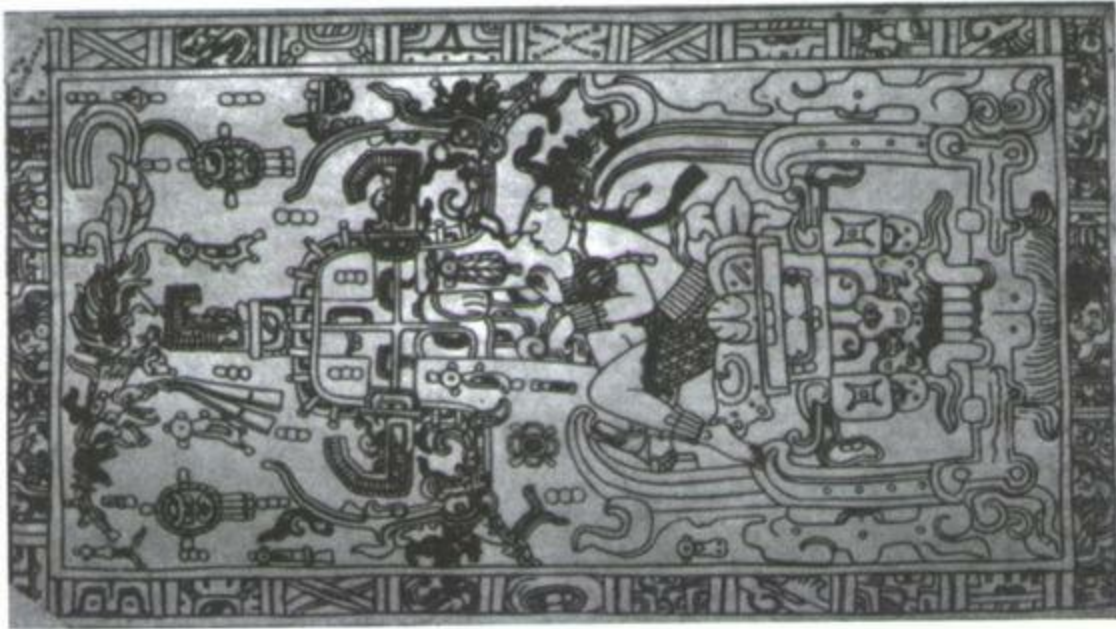

Lord Pacal of Palenque

While many revisionists see in Pacal’s sarcophagus a corroboration of their “ancient astronauts” theory and are quick to dismiss its mythological connections, there really is no reason to oppose the mythological elements of the sarcophagus lid from what are also very suggestive elements of stylized technology and transportation.

Why this is so may be seen from the fact that, as author and alternative researcher David Hatcher Childress observes, the “sacred bird, sun and moon motifs” that appear to the left of the picture “signify the upper world, while the monster below signifies the under world. The ancient Chinese had the exact same belief in three interlocking worlds.”⁵⁰⁹ Indeed, the theme of the three interlocking worlds is a common one in most mythological traditions.

But Pacal, as was seen, is an example of the “Red Paint People,” and it is this connection which with its own network of concepts, traces to Egypt, and to the possibility that, in Pacal’s case, the “ancient astronaut” and the “mythological” elements need not necessarily be opposed, but rather, aid in each other’s complete understanding. As Rux observes,

The Red Paint People were written of around the turn of the (last) century by such notable scholars as Lewis Spence in *The History of Atlantis*, and then appear to have been ignored until such anthropologists as Richard Cavendish and Franklin and Mary Folsom brought them up again.... Also known as the “Maritime Archaic” culture circa 5,500-2,000 BC, they were a comparatively tall white race (five-foot eight or taller) who...got their nickname from their practice of sprinkling red ochre paint (common to Egypt...) over their dead.⁵¹⁰

Even more strange is the fact that this “Red Paint People’s” skull measurements and medical defects appear the closest to the Irish, and that their remains have been found over a wide range from Canada, in Labrador and Newfoundland, to Norway, Finland, central Siberia, Mesoamerica, and that their bodies are always buried facing west.⁵¹¹

But why red paint? Why that color in particular? The color itself reveals some interesting associations, again, from legends spanning the globe and seemingly unrelated cultures. The Hopi Indians of North America, for example,

Have “hundreds of tales” about a mysterious Red City of the South from which the kachinas came, where the highest learning and moral instruction were taught in structures specifically designated as pyramids. This may or may not have been the once-red Mayan city of Tikal.⁵¹²

However, notes Rux, the Hopi nation is not “the only tribe with legends telling of a lost red land.”⁵¹³

The “Weeping God” on the Gateway to the Sun at Tiahuanaco⁵¹⁴ is said to cry for “the sunken Red Land.” L. Taylor Hansen, in *The Ancient Atlantic*, quotes a Sioux chief as saying, “...this is the land of our beginning, where we went from the old Red Land before it sank, because *this land is as old as the dragon land of the fire god*” The Apache myth is the same: “Long before the Deluge, we used to live in the land of red fire, in a city whose entrance was hard to find... the mountains were the highest in the world in those days, and deep down in them was the abode of the fire-god...It was through his rage that our old land was destroyed: the god left his underground cave, rose up through the mountain and poured fire and death on the terrified people.”⁵¹⁵

As Rux rightly observes, the last reference could indicate a massive volcanic eruption. But the problem is the lack of agreement between this legend and others; they are simply not agreed in its particulars.⁵¹⁶ Notes Rux, the Awawak Indians likewise have a similar legend about their fire-god, suggestively named “Aimon,” destroying the world by burning and submerging it.⁵¹⁷ The name “Aimon” might refer, as Rux observes, to Amon-Ra, the Egyptian fire and sun god.

And with Ra one has yet another intriguing connection in the catalogue of associations with the color red within mythology, for red is “the color worn in battle by both the Valkyries and Sekhmet,

who the ‘Father of Terror,’ Ra, sent with his eye to burn the human race.”⁵¹⁸ And more importantly, Sekhmet wore red because “it was the color of her homeland.”⁵¹⁹ So here is another curious reference, this time from Egyptian, and not native American Indian, sources associating red with a lost land. Note, too, that Ra is “the Father of Terror,” a designation that would associate him with the Sphinx at Giza, which in the Arabic tradition is known as *Abu-Hol*, the Father of Terrors. As we shall see later on in this chapter, there are yet more references associating Ra with the chimerical figure of a sphinx.

3. The “Underworld” as a Planet

With Ra, we are back to the theme of the Underworld, where we began this excursion with the sarcophagus lid of Lord Pacal in Palenque. Ra, of course, ruled the Egyptian underworld for a time. But the Egyptian underworld, while certainly understood to be a real place beneath or inside of the Earth, was also a place

In “the west,” under the sea or ocean, or beneath the earth. All these locations were one, used interchangeably,

a fact that recalls, once again, the Unified Intention of Symbol. Thus,

Since “sea” or “ocean” can also mean “space”, and there is no up or down in space, it is certainly possible that this Underworld is actually beneath the earth - another *planet*. [520](#)

Alford’s identification of the underworld with a meteor that has crashed into, and sunk beneath, the surface of the Earth has now been stood on its head, for while Alford himself pointed out the meaning of “oceans” and “mountains” and “islands” as “planets in the deep sea of space,” it appears that — in his rush to flatten the multi-tiered meanings of mythological symbols into one flat and utterly prosaic meaning, he has forgotten the very astronomical context of many of his own observations, and forgotten, therefore, that “Underworld” itself may refer not only to the interior of the Earth in a prosaic sense, but also to another planet which was and still is entirely real.

4. *The Red Land, the Red Man, and the Red Planet*

a. *The Red Land*

But *which* planet is meant?

The clues thus far examined, and to be examined, lead inexorably to Mars, the Red Planet. Another clue to the role of Mars in this paleoancient interplanetary war is found scattered throughout Spell 17 of the Egyptian book of the Dead, where a cryptic reference occurs to the “Children of Heaven” who have “entered into the eastern part of the sky,” whence “there straightaway taketh place a battle in haven and in the earth to its whole extent.”⁵²¹

The reference to the “eastern part of the sky” is an astronomical reference, to be sure, but its meaning must not be associated merely as a reference to where the Sun rises. The “eastern part of the sky” refers to those regions of space and the planets that lie outside the Earth’s orbit, Mars, Jupiter, and Saturn, whereas the “western” part of the sky refers to those regions and planets inside the Earth’s orbit, Venus, Mercury, and the Sun itself.⁵²² Thus, if one follows the mythological clues, *the war involved regions outside the Earth’s orbit, as well as the planet Earth herself*. The war, in other words, could have involved the planets Mars, Jupiter, and Saturn, and possibly the satellite bodies associated with them. This is our first real textual clue of *where* the war took place.

There are other indications that support this interpretation. Red, of course, was the color of one of Egypt’s “Two Lands,” the other being black. As Bruce Rux notes,

The Red Land was the Sacred Desert in which the Pharonic Pa-Ra-Emheb Stela *named Ra as the engineer who measured the land and built the ‘protected place’ from which he could ‘ascend beautifully and traverse the skies,’* and the Sphinx in his own image and name (Ra-Harakhte). Red was also the original color of the Sphinx itself, evidenced by the traces of bright scarlet paint still found on its uraeus crest and beard in the British Museum.⁵²³

Ra appears here as nothing less than the Egyptian counterpart, indeed, perhaps merely the Egyptian *name*, of Marduk, who similarly measured the structure of the deep, and who, as a Babylonian god, possessed his own “ekur” or pyramidal mountain temple, a “protected place.” In other words, Ra and Marduk share not only the role of “sun-gods”, but also performed similar functions and were associated with similar technologies. Presumably this is the reason the ancient Egyptians associated the color red with the home of Ra and Sekhmet, and since the latter destroyed the earth with “fire,” also associated red with evil. Note again, the association of Ra with the Sphinx via yet another root, the color which they both share.

b. *The Red Man*

A second association tying Mars to events on Earth is man himself. This association is no mystery to students of esoteric or astrological lore, for the symbol for Mars, ♂ is the same as the symbol for man, ♂. But there is more.

Red is the color of the clay from which Adam was made, and the color associated with the sea Moses crossed in the Exodus. Red is also the color the Egyptians painted the males of their race in hieroglyphs... In addition to its aforementioned meanings, *Adom* means “he of the ruddy complexion,” or “he who is red.” *Adama*, and its parallel Akkadian word *Adamatu*, both had the distinct meaning of “dark red soil” or “dark red earth.” That red soil was taken by Enki from the *Abzu* or Lower World, where he lived, and it was there that he made mankind.⁵²⁴

Alford, of course, would have it that this merely refers to mankind’s life having been “seeded” to Earth by life-bearing meteorites which set the process of evolution in motion. But the ancient texts know of no materialistic concept like evolution.

There is yet still more: the term “Abzu” or “Absu” is not only a term referring to the sun, but also for a boat or ship of some sort which reaches Enki’s world. It may thus be associated with the “solar barques” which ferried the deceased to the afterlife both in the Egyptian and Celtic traditions.⁵²⁵ The texts thus clearly suggest an inextricable relationship between mankind and Mars, but also in some cases even associate the *origins* of mankind, and the Deluge itself, with Mars.

And now the plot *really* thickens...

5. *The Two Sphinxes of Ra, and the Two Eyes of Horus*

As noted above, Ra is associated with the Sphinx. However, as Rux states, there are problems with that association:

Ra was specifically mentioned in Egyptian stelae as erecting a Sphinx in his own image in a “protected place,” i.e., a place of pyramids. Until the discoveries of the Viking probe, we had nothing but Giza to equate that to. But the Cairo Sphinx does not look like Ra, who was depicted as a hawk - the Cydonia Sphinx on Mars does. The very name of this Sphinx is given as Ra Harakhte: “Falcon of the Horizon.” More to the point, Ra was said to wear a diadem on his forehead...

(This is sounding familiar!)

...from which he could fire a bolt to kill his enemies - the Cydonia Sphinx appears to have exactly such an item sculpted on its forehead.^{[526](#)}

But why refer to the Cydonia Face as a Sphinx at all?

Alternative researchers George J. Hass and William R. Saunders, in their remarkable and provocative book *The Cydonia Codex: Reflections from Mars*, summarize the history of Richard Hoagland’s, and his associate, Dr. Mark Carlotto’s identification of the Cydonia face as a Sphinx in the following manner:

In 1984, Hoagland proclaimed the “Face on Mars” to be the embodiment of a Martian Sphinx where the face was half humanoid and half feline. The profound implication of Hoagland’s claims was that an identical fusion of two specific combinations of humanoid and feline features exists on massive structures on two different worlds: Earth and Mars. Using computer enhancements of NASA’s Viking Frame 70A13 by Dr. Mark Carlotto, Hoagland produced a mirror split of the “Face.” He was astonished with the results and quickly adopted the title of Martian Sphinx in reference to the “Face.”^{[527](#)}

We can perform this experiment ourselves.

First, the Viking frame 70A13:

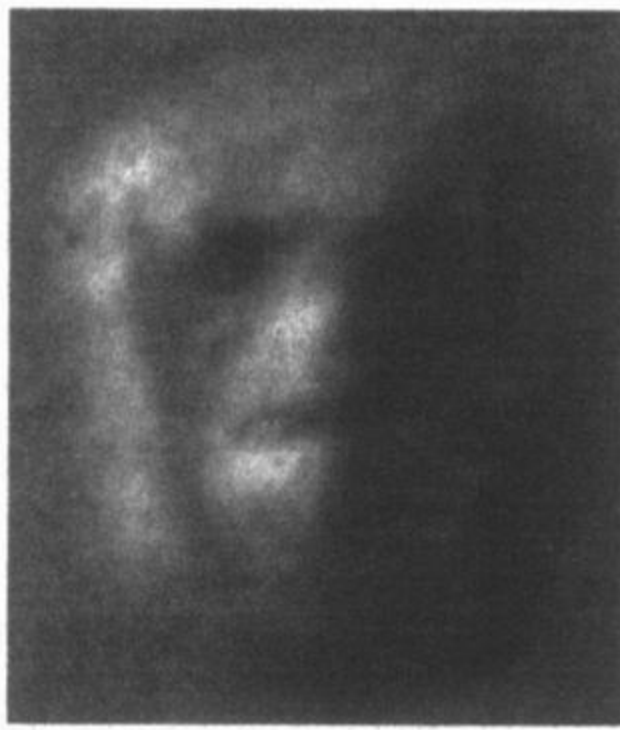

Then, Carlotto's computer enhancement:

Carlotto's Enhanced Image of Viking Frame 70A 13.



If one now pauses and recalls Rux's comments, it would appear that there are *three*, and not just two, types of forms being morphed into this fascinating figure, for clearly, while the left and right sides each have their own peculiar humanoid and feline characteristics, as we shall see in a moment, their *overall* combination could be loosely construed as ornithological, or bird-like. The author can only add that his own personal reaction, when he first saw this image, was one of fright and fear. In short, my reaction to this face is that it conveys a malevolent intention, an intention that will, I believe,

become more apparent with the later images.

In any case, Hoagland correctly identified the humanoid and feline aspects of this Martian Sphinx.



And Hoagland's humanoid aspect is no less apparent:



The above image, in my opinion, is not the countenance or visage of “love, harmony, and peace”; it is most decidedly not Disneyworld “jonquils and daisies.”

But then came the images from the Mars Orbital Camera, in 1998, and it appeared as if the whole Martian Face-Sphinx controversy would die down, for as nationally syndicated radio talk-show host Art Bell quipped, the image looked like a cat's litter box, and the name stuck. The image became

“The Catbox Image:”

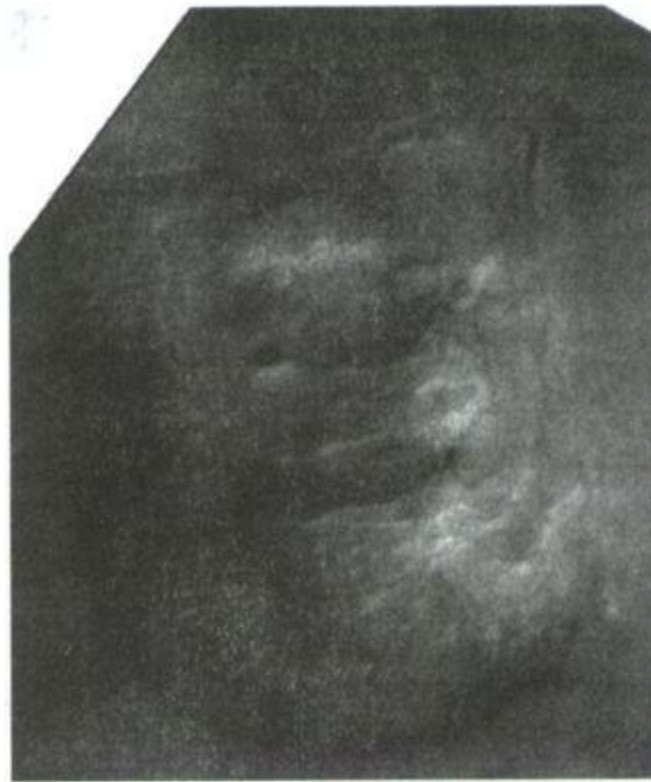

But careful scrutiny of the image will show face-like features. The question then became whether this image preserved the peculiar double morphology of a Sphinx. If so, then it was, once again, an artificial structure, albeit one in great decay. Haas and Saunders set out to do just that.

This time, much to the chagrin of “it’s just a mesa” proponents, the flipping of the image, after computer rectification to provide an overhead view that *could* be flipped, was nothing less than astounding, as Haas and Saunders point out.

1998 Mars MOC Image, Flipped for Feline Component

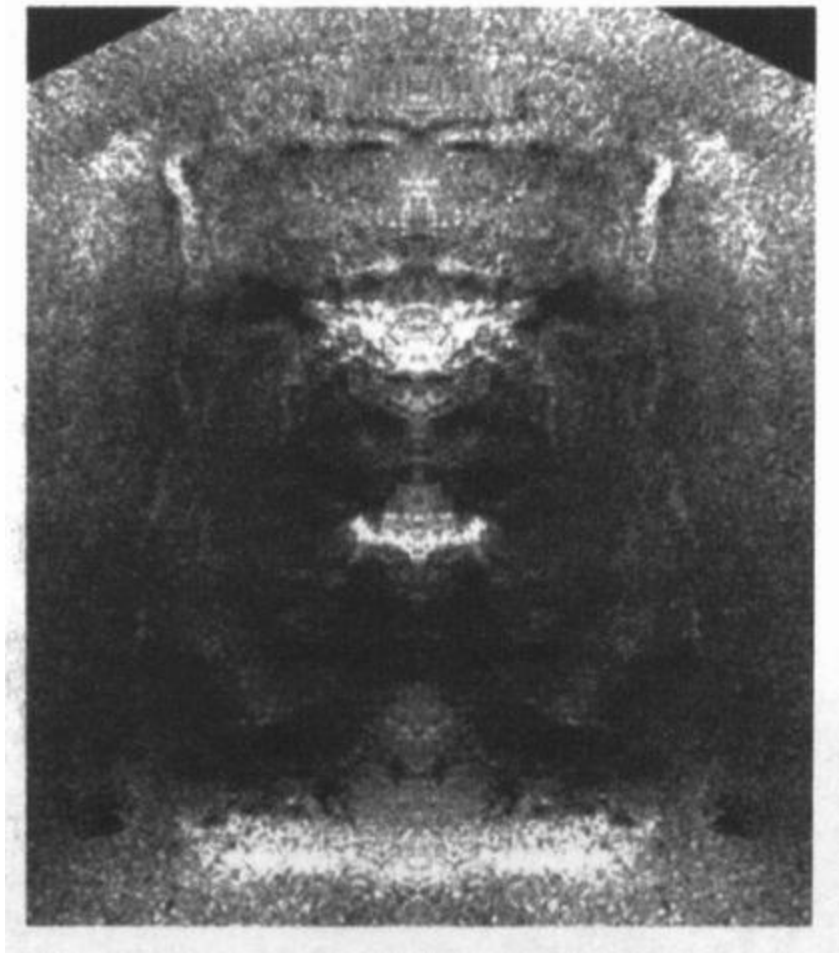

If anything, the improved optics of the 1998 Mars Orbital Camera only *enhanced*, rather than overturned, Hoagland's original Sphinx hypothesis, providing a confirmation of it. The resemblance of the image to a head-on image of an African male lion is all too apparent and palpable.

But what of the humanoid component?

Here the results were even more astounding, for not only was the humanoid component confirmed, but Rux's additional comment that the "headdress" of the Face appeared to show a *diadem* or *jewel* of some sort, as associated with Ra's "eye", appeared to be confirmed in no uncertain terms, a fact made all the more remarkable in that Rux wrote his comments in 1996, fully two years before the image was even captured by the satellite's camera!

1998 Mars MOC Picture, Humanoid Aspect with Clearly Visible Diadem



Ra then, is associated with *two* Sphinxes, one on Earth, and the other, paradoxically, on Mars.

But there is still more.

Rux again points the way to yet more Mars-Earth connections by stating that

On the painted papyrus of Queen Nejmet in the Egyptian Department of the British Museum is : red planet to the right, surmounted by Harpokrates, the young Horus - it is called “The Red Eye of Horus.” Horus is sometimes referred to *as having “two red eyes” or “two blue eyes”, or as having one red eye with the other blue.* Ra’s “right eye” and “left eye” being used to refer to the Sun and Moon respectively, and “Thoth’s eye” used to refer to the Moon, we know that “eyes” are sometimes used by the ancient Egyptians to refer to planets. Horus lost one of his eyes in battle with Set during the civil wars, having it restored to him by the magic of Thoth...it is not unreasonable to assume ...that Horus’ blue eye would of course be the blue planet, Earth. As reasonably, his red eye would be Mars. [528](#)

In other words, Earth and Mars describe two parts of an interplanetary relationship — a civilization.

But Rux then notes a disturbing aspect to this use of “eyes” to mean planets: “An ‘eye’ also can represent a weapon and/or a ship, as has been demonstrated.”[529](#) Moreover, if viewed as a ship, and if one “enters the vehicle which is ‘the eye of Horus,’ it powers up, and one goes from the blue to the red — more specifically, in the typical dual meaning of ancient sacred puns, from his ‘blue eye’ to his ‘red eye,’ or from Earth to Mars.”[530](#) Indeed, if this “ship” were based on any sort of field propulsion,

its ionization of the atmosphere would first start on the blue end of the electromagnetic spectrum and as the “ship” swiftly receded from its point of origin, its radiation would undergo the classic Doppler phase shift, from blue to red.

Such a trip is related to the Egyptian concept of the *Tuat* or *Duat*, which, since it contains neither water nor air, and is “an unfathomable abyss... dark with the blackest darkness” wherein a man can wander, and in which there is no life, is space itself.⁵³¹ At this point, notes Rux, a journey through the *Tuat* “not only involves one Sphinx - it involves *two*.”⁵³²

A double sphinx (*Aker*)⁵³³ can be seen depicted in the Pyramid Texts and the Book of the Dead, being either two sphinxes back to back with a solar disk between them, or else a single body with one head gazing eternally east (as ours does at Cairo), and the other gazing eternally west...it is referred to as the “Great God who opens the Gates of Earth.”⁵³⁴

The Pa-Ra-Emheb Stele, moreover, refers precisely to “Ra’s building of the Sphinx in his image amid a ‘protected place in the Sacred Desert’ with a ‘hidden name,’ the place of the ‘King of the Gods’ in the ‘secret underworld’.” Additionally, this stele also mentions “the extension of cords and a crossing of the sky to the subterranean world where secret things are made.”⁵³⁵ And as if that were not enough, Rux states that Wallis Budge himself wrote in 1934 that

Mars... was called Hor-Tesher, the “Red Horus,” He was said “to journey backwards in traveling,” and he was also known as “Harakhti,” “Horus of the Two Horizons.” *The God of this planet was Ra; he had the head of a hawk with a star above it.* The Cydonia Sphinx of Mars is to all appearances exactly that: the head of a hawk with a star above it, the star (diadem) containing a stylized human face.⁵³⁶

Consequently we have the following relationships:

- The association of Mars with Ra;
- Ra’s association with two sphinxes;
- The existence of the Sphinx at Giza, which may be associated with Ra through the use of red paints on its beard;
- The apparent existence of a sphinx or chimerical Face on Mars, depicting both humanoid and feline aspects in its two halves, and an ornithological or bird-like quality when viewed as a whole, which is associated with Ra’s depiction as the “Falcon of the Horizon;
- The use of the term “eye” to refer not only to planets, as with the red and blue eyes of Horus referring to Mars and Earth respectively, but also to refer to weapons, as with the Eye of Ra, which is used by Sekhmet to destroy all life on earth in a fiery conflagration;
- The association of Ra’s “eye” with his diadem, which parallels the *lapis exilis* or “stone of power” of Lucifer in the Christian tradition,⁵³⁷ and the evident presence of just such a diadem in the “humanoid” version of the 1998 Mars Orbital Camera’s imaging of the Martian Sphinx;
- The apparent association of Ra, as a sun-god, not only with *light*, but apparently with crystals, as

with the stone or “eye” of his diadem;

- The association of mankind, of *Adam*, with the “red earth“, i.e., the Red Planet of Mars; and, from chapter two,
- The association of Mars with the “scarred warrior” of some ancient mythological motifs, a scarring quite visibly demonstrated in the massive scar of the *Valles Marineris*.

And last, but surely not least,

- The clear association of Mars with warfare.

These associations allow us to hypothesize both who was involved in this paleoancient war, and where it was fought, for these associations indicate that the warfare referred to in ancient Sumerian and Egyptian texts was interplanetary - cosmic — in nature, and involved at the minimum, both Mars and Earth, and their “gods.” And we have now yet another variation on our now familiar formula:

Mountains \approx Celestial Bodies \approx Pyramids \approx Eyes \approx Weapons.

Perhaps, in the light of this formula, it is not surprising that the Martian Sphinx should likewise be near a “protected compound” of pyramids, the most massive of which is the celebrated five-sided D & M Pyramid! We would, however, be remiss if we did not take note of the other players...

6. Saturn and Jupiter

Interestingly enough, Scandinavian tradition records that Saturn (Greek *Kronos*) was involved in dismembering the body of the deity Mimer, yet another mythological allusion, from a wholly different quarter than that of Sumer or Egypt, with their “dismembering” of Tiamat or Osiris, indicating that Saturn, perhaps, or one of its satellites, may have also been involved in this ancient war.⁵³⁸ Similarly, Marduk, as a sun-god, is associated not only with Ra and the Sun, but also with the planet Jupiter. We have already observed that De Santillana and Von Dechind note the peculiar association of Saturn with Mars.

But while there is abundant evidence that Mars might have once been a water bearing planet and, as the Martian ruins attest, home to intelligent life, the picture is not so easy when it comes to the two gas giants of the solar system. Clearly neither could be the home to any intelligent life as we know it.

However, Richard C. Hoagland has recently pointed out the peculiarly *artificial* characteristics of Saturn’s little moon, Iapetus, in a brilliant, and breathtaking paper posted on his website, entitled “Moon with a View.”⁵³⁹ We shall have more to say on this matter in a subsequent chapter. But for now we merely note the following: *external planetary evidence from Saturn’s moon Iapetus would appear to corroborate in loose fashion the mythological association of Mars, Earth, and Saturn in an ancient interplanetary war that destroyed a civilization based in part on those worlds.*

In this regard it is intriguing that Rux finds an association of the Egyptian god Thoth with the ringed planet.⁵⁴⁰ Moreover, one version of the Book of the Dead, the Ra papyrus in the Leiden Museum even has Thoth ordering the Deluge.⁵⁴¹ The association of Thoth with the Deluge has been noted elsewhere,⁵⁴² but now Thoth clearly enters the picture as one of the main players not only in events subsequent to the Deluge, as much esoteric tradition maintains, but in events leading up to it. He becomes a part of the conceptual matrix along with Ra, Marduk, Ninurta, Nergal, the Sun, the Earth Mars, Saturn, the war, and its associated technologies. And as if all of this were not enough to consider, even rabbinical tradition associates Mars with the serpent of Paradise.⁵⁴³

In the face of all these diverse and yet intricately interlocking details, it is perhaps not surprising, then, that the Hopi Indian nation of North America has a tradition that the world in and on which they live is their *fourth* world. Their third world, to which they fled after their second world was destroyed, was not only colored red, but lay in the astronomical “east”. After their arrival here, on their fourth world, the former red world was now referred to as being in the west. As Rux observes,

This, along with *the description of a world destroyed by spinning off its axis and perishing in a Flood*, make for a good argument that Earth was abandoned for Mars, then was returned to when Mars itself was later destroyed - or perhaps that the Hopi Second World was that shattered planet (mythically referred to in Babylon as Tiamat) which is now the asteroid belt between Mars and Jupiter.⁵⁴⁴

Perhaps the reference to a world “spinning off its axis and perishing in a Flood” is not to be interpreted in the standard sense of most catastrophists as a world knocked off its axis of rotation, but

of a world knocked off *its axis of revolution around another planet*. If so, then the Hopi tradition provides yet another mythological confirmation of Van Flandern's multiple Exploded Planet Hypothesis, where the first event destroyed a large, ancient water-bearing planet, freeing its satellite (Mars), and concussing it with a massive shock wave of debris and water in a planetary Deluge and destruction by fire.

In any case, one thing should now be apparent, and that is that the standard models of interpretation of these myths - be they catastrophist or Jungian — simply cannot account for the presence of artificial structures on our nearby planetary neighbors nor for the many mythological connections between the Earth and Mars, connections those very artifacts attest to, much less can it account for the fact that one entire moon, Iapetus of Saturn, exhibits all the characteristics of being itself a gigantic artificial artifact and satellite. But the cosmic war hypothesis can do so, and moreover, is corroborated by their existence in a detailed correspondence between mythological motifs and external evidences that the other methods of mythological interpretation simply fail to account for. The actuarial probability that all these correspondences are merely coincidental would be astronomical.

However, important questions and tasks remain, for a broad chronological framework has yet to be extrapolated, and more importantly, the moral character of the combatants, and the enduring legacy of the war itself, have yet to be considered in detail....

THE GOOD, THE BAD, AND THE NEPHILIM

“In virtually all of the mythologies of the world there is the theme of an ancient conflict among the gods. In Egyptian myth it is the conflict of Osiris and Horus against Set; in Babylonian myth it is the battle of Marduk against the primeval goddess Tiamut; in the Canaanite myths of Ugarit it is Baal against Yum and Mot; and in Greek myth it is Zeus against the Titans. All of these conflicts relate in one way or another to the original conflict, the first divine conflict ever set down in writing, which was the ongoing conflict between Enlil and Enki as told by the ancient Sumerians. ”

Peter Goodgame⁵⁴⁵

Certain “characters” from ancient myths have repeatedly appeared throughout this work: Ra, Marduk, Ninurta, Nergal, Thoth, Zu, and to a lesser extent, Horus, Osiris, and by implication, the consorts of all of these. This cluster of names from Mesopotamia and Egypt highlights the cultural milieu from which our own culture’s biblical basis derives, and the poles between which it thus moves. Like all such traditions, it has its own unique way of recounting the same events, and its own unique perspectives on why the events happened. This broad Mesopotamian-Egyptian context, however, is one largely hidden from most of the public and accessible only to a few specialists, or more recently, to those interested in pursuing alternative or revisionist paradigms of ancient human history.

Accordingly, in order to gain an appropriate perspective from which to view the peculiarly biblical understanding of some of these events, it is necessary to place them against the backdrop of the relationships of the above personages. And the term “relationships” here is to be understood in the fullest sense of the term, for it is a little known fact that the genealogies of these individuals may be reconstructed from the ancient Mesopotamian myths. One scholar who has taken the time to do this is Laurence Gardner, in his book *Genesis of the Grail Kings*. When one views his genealogical charts one gains that additional and much-needed perspective on why the cosmic war was considered by so many cultures to be a war of rebellion, a “civil war in the pantheon.” One also gains an immediate understanding of the central role of mankind in this struggle, and a unique and ancient perspective on answering some age old biblical riddles. We shall present the first three of Gardner’s genealogical tables, and then comment on each of them as a way of beginning to answer the important questions of “Who were the ‘good’ guys and the ‘bad’ guys in this war? And *why* were they good, or bad?”

Before doing so, however, a generalized comparison and cautionary note on Biblical and Sumerian parallels is in order.

A. General Observations and Cautionary Notes on Sumerian and Biblical Parallels

Ever since Frazer's *The Golden Bough* was published in the last years of the nineteenth century, it has become an academic fashion to point out the parallels between biblical stories and motifs and those found in other traditions and mythologies. One theme in particular, that of the "dying and rising god" became a favorite, with many scholars pointing to Egypt's god Osiris as perhaps the best non-Christian example of this motif. Osiris, then, may seem like a very unusual place to begin a series of generalized observations and cautionary notes about the Sumerian and Biblical parallels, but it will become highly relevant as we proceed in this chapter.

We will begin with the Coffin Texts from ancient Egypt, which provide two intriguing comments about Osiris:

This is the sealed thing which is in darkness, *with fire about it, which contains the efflux of Osiris*, and it was put in Rostau... (Coffin Texts, Spell 1080)

This is the world which is in darkness. As for any spirit who knows it, he will live among the living. *Fire is about it, which contains the efflux of Osiris*. As for any man who shall know it, he will never perish there, since he knows what shall be in Rostau... Rostau is (another name) for Osiris..." (Coffin Texts, Spell 1087). [546](#)

Recall that "Rostau" was another name for the underground complex of tunnels at Giza, and by implication, was a metaphor of the "Underworld" itself. Osiris is thus identified in the Coffin texts with this "Rostau" underworld of tunnels. Moreover, note that the Coffin texts imply that some sort of technology guards Osiris' "efflux." Osiris, in other words, is *not* a good example of a "dying and rising god" — in spite of what many academics would maintain - for a very simple reason. In fact, as Peter Goodgame has aptly observed, Osiris would actually seem to be "*the least-suited* to be a member of the category," for the simple reason that his rising was not bodily, but in the spirit world. As far as this world is concerned, Osiris is a "dead and gone" god, not a "dying and rising" god. [547](#)

But why would Egypt develop such a complex religious and philosophical tradition to begin with, especially since Egypt springs, fully fledged, into being almost from nowhere. As John Anthony West and many other alternative researchers have observed, Egypt itself maintains that it is a legacy of something else. But the view was once not restricted merely to alternative researchers. It was once the considered opinion of academe's most respected mainstream scholars, among them the father of modern Egyptology, Sir William Flinders Petrie. Petrie put forward his own theory after his lifetime of exhaustive study, a theory known as the "Dynastic Race" theory. Petrie maintained that

In the pre-dynastic era Egypt was invaded by a technologically superior group of elite foreigners *who came originally from Mesopotamia*. This "Dynastic Race" invaded and conquered Upper Egypt and settled... near where the important cult centers of Abydos, Thebes, Luxor and Edfu would later emerge. Petrie referred to this invading force as the "Falcon Tribe," and the name of their capital of Nekhen means "City of the Falcon." [548](#)

But as Peter Goodgame correctly observes, this racially-based theory quickly fell into disrepute in academic circles after the horrors of World War Two and the Nazi party's genocide in the name of racial superiority. It was replaced with an ill-considered "nationalism" in Egyptology as the former European colonies of Africa broke away from their former superintending imperial powers. Nonetheless, Petrie's theory appears to have great merit, for it explains why there are so many detailed comparisons between the mythologies of Egypt and Mesopotamia, comparisons illustrated in the peculiar conceptual parallels between Edfu and the Tablets of Destinies.

Sumeria, then, forms the other terminus, along with Egypt, between which the Biblical narrative of the Old Testament flows, and thus it was only natural for scholars to seek parallels between the two.

And parallels there undoubtedly are.

Peter Goodgame puts the case for these parallels, and the problems they raise, in very precise terms:

Much of pagan mythology and religion, in its many different forms and cultural expressions, can be traced back to this original conflict, but it is interesting that the accounts that most closely parallel the Sumerian accounts of creation, of the gods, and of human civilization and religion, are not to be found in later "pagan" traditions, but are instead found in Hebrew accounts, specifically the book of Genesis. Both the Sumerians and the Hebrews told a story of mankind being created from the earth of clay with divine assistance; both sources refer to an ancient dispute between a farmer and a shepherd; both give an account of gods or angels descending from heaven and influencing human civilization; both mention the creation of the first city; both testify of a great flood that covered the land which wiped out civilization and almost all of mankind; and both speak of the conquests of a great king who was involved in some way with a great temple or tower and with the creation of the many languages that divided the nations.⁵⁴⁹

But this raises a very obvious and pertinent series of questions.

How could such a strict form of Hebrew monotheism have "evolved" from the liberal and diverse polytheistic religion of the Sumerians? Another way to pose this question is: Where is the God of Israel to be found within the Sumerian pantheon? This is a good question to ask because Abraham, the founder of the nation of Israel, was supposedly called out by God from the city of Ur, which was located in the heart of the land of the Sumerians.⁵⁵⁰

To put it differently, we are looking at two parts of a whole, with each part representing two very diverse and antithetical theologies.

But this does not answer the question Goodgame poses: Where in the Sumerian pantheon would one locate the Hebrew God, Yahweh? Or to state it differently, where in the Hebrew "angelic hierarchies" would one place the principal Sumerian gods? However one asks the question, the fundamental problem remains. There are, notes Goodgame, three main contenders for the Sumerian equivalent of the Hebrew God Yahweh: Anu, Enlil, and Enki.

The Yahweh-Anu parallel is exemplified in two major ways, according to Goodgame. Anu is, like

Yahweh, a “father” god dwelling in the uttermost and inaccessible glory of heaven.⁵⁵¹ But the “apparent relationship between YHWH and Enlil is much more substantial.” Even though Enlil was not viewed by the Sumerians as the original creator god, he nonetheless was the ultimate King over all gods, and over mankind as well, and some Sumerian myths even refer to Enlil, and not Enki, as the creator of mankind. This important point - the disputed origin of mankind through the action of Enlil or Enki - is, as we shall see, ably resolved by Laurence Gardner by reincorporating the Hebrew component into the story. But there is one last important Yahweh-Enlil parallel, and that is that both gods directly order the Flood.

But it is, paradoxically, the parallels between Yahweh and Enki that are the most pervasive, persuasive, and disturbing, for Enki would in some lights also appear to be the best Sumerian candidate for a parallel to the Biblical tradition’s Lucifer. Goodgame notes that Enki, like Yahweh, is the most “personal” of all the Sumerian gods, and like Yahweh, he was “viewed by the Sumerians as powerful, kind, and wise in his schemes to protect the Sumerians from the animosity of other gods (especially Enlil) and from neighboring enemy tribes.” And in many Sumerian myths it is Enki, and not Enlil, who is personally involved in the creation of mankind, though as we saw in a previous chapter, by a particularly grizzly method.⁵⁵²

However, the closest parallel between Enki and Yahweh lies at what is the most important theophany in all the Old Testament, that of Yahweh to Moses in at the Burning Bush, recounted in Exodus 3:13-14:

13 And Moses said unto God, Behold, when I come unto the children of Israel and shall say unto them, The God of your fathers hath sent me unto you; and they shall say unto me, What is his name? what shall I say unto them? And God said unto Moses, I AM THAT I AM: and he said Thus shalt thou say unto the children of Israel, I AM hath sent me unto you.

David Rohl, another scholar of these parallels, explains the theophany’s Sumerian background and its densely punning word play this way:

As we have learnt, Enki... was called Ea in Akkadian (East Semitic)-that is to say in the Babylonian tradition. Scholars have determined that Ea was vocalized as “Eya”. So, when Moses stood before the burning bush and asked the name of the god of the mountain, did he really reply “I am who I am”(Hebrew *Eyah asher eyah*)? This puzzling phrase has long perplexed theologians⁵⁵³ but now there is a simple explanation. The voice of God simply replied “*Eyah asher Eyab*”-“I am (the one) who is called Eyah” the name of Ea in its West Semitic (i.e. Hebrew) form. Scholars have simply failed to recognize that this is another of those characteristic puns in which the Old Testament abounds. “I am (*Eyah*) he who is called (*asher*) Ea (*Eyah*)” is a classic biblical play on words. It also explains God’s apparently nonsensical instruction: “This is what you are to say to the Israelites, “I am has sent me to you.” God’s words should really be translated as “Eyah has sent me to you.”

“Eyah” or simply “Ya” is the hypocoristic form of the name Yahweh found as an element of so many Old Testament names. So Enki/Ea, the god who created Man and then later warned Zuisudra/Utnapishtim of the impending destruction of mankind, is one and the same as the god of Moses.⁵⁵⁴

But there all similarity ceases. While not discounting the probable biblical relationship of Yahweh to Enki, the two figures nonetheless possess important distinctions. Enki, for one, is a sorcerer, experienced in the practice of magic of all varieties, whereas the biblical traditions of Yahweh specifically prohibit such practices. Moreover, Yahweh in the biblical tradition is clearly associated with the actual first creation as well as with the creation of mankind. Enki, on the other hand, has no such honor in the Sumerian texts, being associated only with the creation of mankind, but not the first creation itself. And finally, there is no special “covenant relationship” between Enki and the Sumerians, while there is between the Yahweh and the Hebrews.⁵⁵⁵

With these thoughts in hand, we are now able to view Gardner’s use of the Sumerian and Biblical-Judaic tradition to compile a total picture. We shall cite only the first three tables of Gardner’s extensive “divine genealogies.”

B. Sir Laurence Gardner's Genealogical Tables

The first table understandably is the most ancient, going far back into the mists of pre-history, to the original revolt of Tiamat, to her theft of the Tablets of Destinies, and to her subsequent destruction in a war by Marduk.

1. Gardner's "Grand Assembly of the Annunaki"

The Grand Assembly of the Annunaki [556](#)

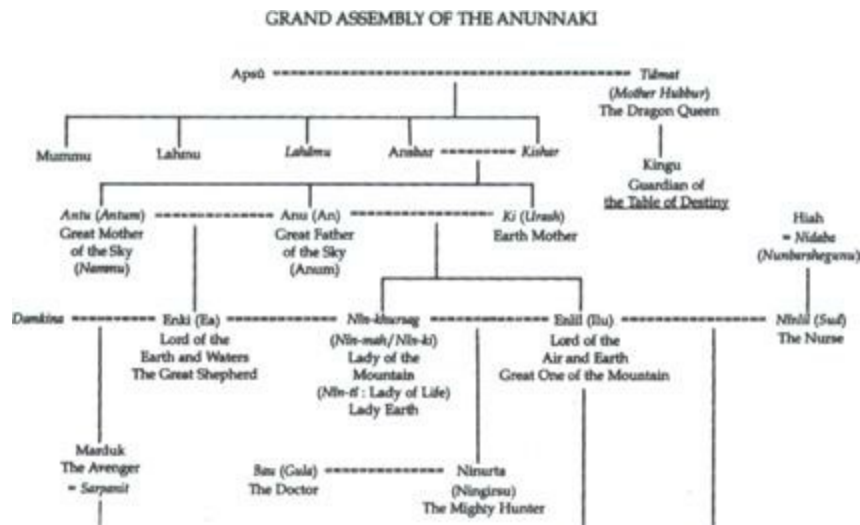

There are a number of crucial points to be observed about this chart. First and foremost is that it preserves the mythological character of Tiamat, Apsu, and An. Tiamat, it will be recalled from previous chapters, is not only a galactic symbol as De Santillana and Von Dechend averred, but also a planetary symbol, as well as a symbol for the primeval waters of chaos. Absu is the “Abyss” or primordial deep itself, and sometimes functions as a symbol of the Sun. Anu and Ki are two of their “children”, and clearly this distinguishes them from Tiamat, because the genealogical chart supports the notion that as a planetary symbol, Tiamat does not refer to the Earth, but to “Elsewhere,” to the first exploded planet, and perhaps to an even more galactic context.

Secondly, observe the “marriage relationships” between brothers and sisters, and, as will be seen in a moment, between half-brothers and half-sisters. This is one of the stable features both of Mesopotamian and Egyptian dynastic practice.

Thirdly, observe that these “consanguineous” relationships assume particular importance with the two great Anunnaki gods Enlil and Enki, both brothers who share their sister Nin-khursag, or Ninursag, as their wife. In this context, the placement of Marduk becomes paramount, for as a son of Enki, he is on the opposite side of the family - one “great big happy pantheon” all! - from his distant “great-grandmother” Tiamat - whom he would eventually destroy - and from the Enlil side of the pantheon. Note too that Marduk is cousin to Ninurta.

Finally, note that many of the gods are “titled,” as being lords or “gods” of a particular realm, or, alternatively, a specific functional “department” of the “pantheonic government.” Thus, one might likewise be looking at a genealogical chart of the relations not only of individuals but of dynasties.

Thus, when Marduk recovers the Tablets of Destinies from Tiamat, their possession passes from one side of the “family” or pantheon, to the other. If this sounds a little farfetched, one need only

recall that World War One, from a certain point of view, may be understood as a family “feud” of gargantuan proportions between the Von Hohenzollerns in Germany, the Romanovs in Russia, the Von Sachse-Coburgs (Windsors) in England, and the Von Hapsburgs in Austria, all of which families were intricately and inextricably interrelated through decades of intermarriages. Kaiser Wilhelm was thus a cousin to Tsar Nicholas *and* to King George, a nephew of Queen Victoria, and a distant relation of Kaiser Franz Josef of Austria, King Leopold of Belgium, and King Vittorio Emmanuel of Italy! World War One, viewed in this somewhat simplistic and very over-generalized light, was a “civil war” of sorts, between the interrelated Houses of Europe. The same holds true of the Sumerian and Babylonian traditions of the cosmic war; it is in every respect *a family war*, a civil war and revolt in the pantheon.

2. The “Grand Assembly of the Anunnaki” and Mankind

However, it is at the second of Gardner’s genealogical tables that things begin to become very interesting indeed.

*Gardner’s Fourth through Sixth Generations of the Grand Assembly of the Anunnaki*⁵⁵⁷

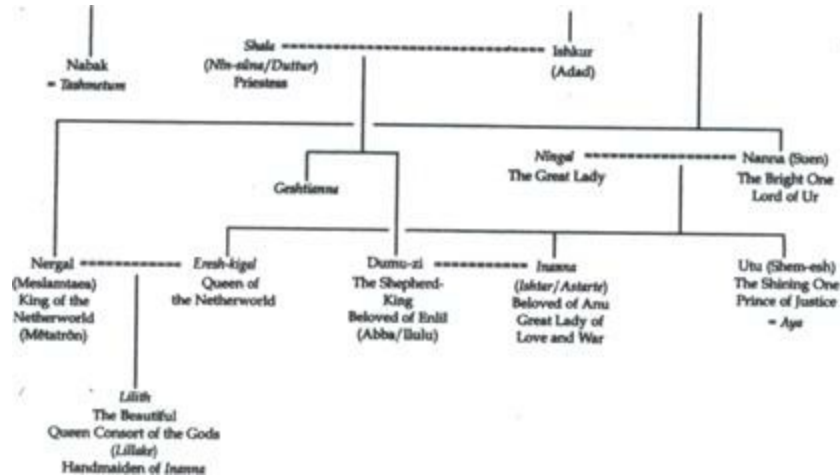

The reader should bear in mind that the solid lines of this chart connect with the ones in the previous table. Thus, Nabak is the son of Marduk, while Nergal is revealed to be the son of Enlil and Ninlil. Consider what this means from the point of view of the texts examined in chapters five and six: it means that Enlil and Enki, who themselves at some point are guardians or keepers of the Tablets of Destinies, have “traded off” guardianship of the objects from one side of the pantheon to the other, *or* that they became booty of war in the pantheon’s ongoing warfare. Recalling that Nergal is also the “god” of Mars and war, and at one brief period also in possession of the Tablets, it would seem to indicate that they had not only been passed from one wing of the pantheon family to the other, but from one planet to another, from Earth to Mars or vice versa. This would be corroborated by the interplanetary implications of the Two Eyes of Horus, as discussed in the previous chapter.

But note who Nergal’s daughter is: the infamous Lilith of Jewish tradition, Adam’s first wife.

Thus, at the final tier of Gardner’s three initial genealogical charts, we arrive at Adam, Eve, and Lilith. And at this point an even *more* suggestive and intriguing set of relationships becomes evident.

3. The Anunnaki and Mankind: Adam, Eve, and Lilith

Gardner's Chart of the Sumerian Version of Adam and Eve [558](#)

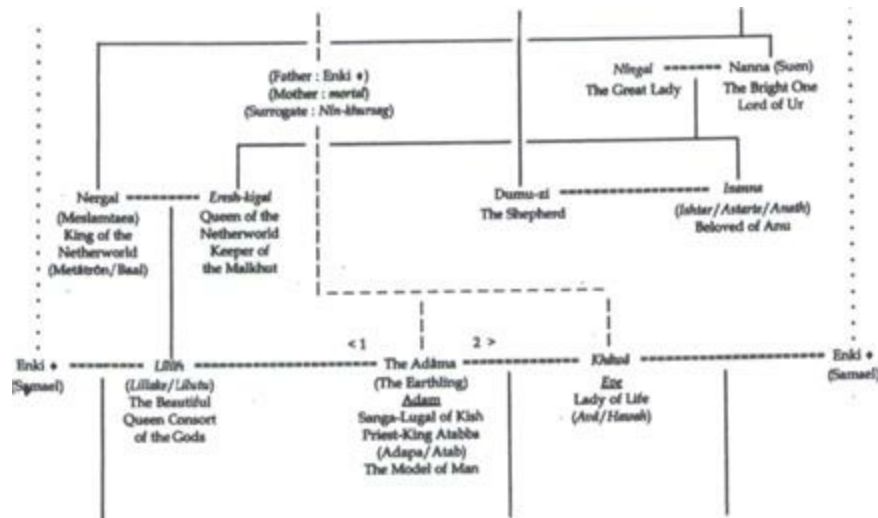

Note that Lilith, daughter of the notorious character Nergal whom we encountered in chapter five, is married in turn both to Adam *and to Enki, who likewise shares Eve with Adam*. Viewed in a certain way, it is a “marriage of political expedience” for the two sides of the pantheon - Enlil’s and Enki’s - are reunited in mankind himself. If one recalls what was said in the previous chapter about the peculiar associations within esoteric literature of mankind with Mars, then this chart gives yet one more detail testifying to a connection between mankind and Mars, this time via Lilith and her relationship to Nergal. Note something else. Enki, who figures previously in the charts as an *ancestor* to all these figures - Adam, Eve, Nergal and Lilith - is now not only ancestor and consort to the two *female* figures, but also both ancestor, brother-in-law, cousin, and son-in-law to the *male* figures. This means that Enki, in a certain sense, is “still around,” i.e., *that he is either very long-lived, or that the name “Enki” refers to someone from the House of Enki*. Either way, the chart points up a significant problem, and it is best to examine it here.

From one standpoint, Gardner’s research provides an answer to the age-old question that has haunted biblical scholars, and that is that the book of Genesis only records Cain and Abel as the offspring of Adam and Eve, and yet, in Gen 4:17, Cain sires offspring of *his* wife. Where did she come from? The standard answer has always been that this unnamed wife was some other child of the biblical progenitors of humanity Adam and Eve. The Sumerian context, Jewish tradition, and Gardner’s charts suggest another answer altogether: Cain’s wife may have been a descendant of some *other* wing of the pantheon.

Let us also recall who and what the Anunnaki are and mankind’s relationship to them. Note the dotted lines connecting Adam and Eve to the rest of the pantheon. According to the interpretation of Sitchin and others, the Sumerian texts indicate that Adam and Eve were deliberately and genetically engineered creatures, a hybrid between the Anunnaki themselves, and a proto-human hominid already

in existence on Earth. Man was thus part “clay” and part “god.” In this the biblical and Sumerian versions are not so different, and even in the biblical version of the creation of mankind by the direct action of God, there is a parallel, for in the Sumerian version the creation of mankind is similarly by the direct action of the “gods,” the Anunnaki. Only the mechanism of creation differs between the two versions, for the Sumerian version has it that the “clay” in mankind is precisely a pre-existing living creature genetically adaptable to, and adapted by, the Anunnaki. The Anunnaki, in short, are the Sumerian equivalent of the Nephilim, the “sons of God,” of Genesis 6.

Note what this means for the “situation” of mankind in the Sumerian version: mankind - Adam and Eve’s direct descendants - *is not directly connected to either side of the pantheon*, whereas there *is* a continuation of the Anunnaki line via Enki and Lilith, on Nergal’s side of the pantheon, and there is also a *further hybridized part-human, part Anunnaki line deriving from Eve and Enki on the other side, a line independent of Nergal’s “more pure” Anunnaki line*. Mankind exists in a precarious middle ground between these two dynastic lines.

The obvious implication that follows from this should not be left unstated, for these charts indicate that ancient Sumerian belief was that their “gods” were *real personages, capable of interbreeding with mankind*.

Viewed in this light, the Sumerian texts indicate that there are *three* major lines of players on the field after the creation of mankind:

1. The “pure” Anunnaki line of Nergal-Enki-Lilith;
2. The “corrupted” and ultra-hybridized Anunnaki-human line of Enki-Eve; and,
3. A “pure” human line of Adam and Eve.

This is a dynamic tailor-made for conflict, for there are two “pure” lines, the Nergal Anunnaki line, and the Adam-Eve human line. But there are also two “hybrid” lines, the hybrid Anunnaki-human line of Enki-Eve, and the line of mankind from Adam and Eve itself, which is a “less hybridized” line. Finally, there are two Anunnaki lines, the line of Nergal, and the line of Enki-Eve.

It is interesting to ponder the second of these lineages, the “corrupted” or “ultra-hybridized” line of Enki-Eve, from the standpoint of the biblical tradition of the “Nephilim,” of the “sons of God” of Genesis 6, who came down from heaven, and sired hybrid chimerical children of “the daughters of men,” producing a race of giants, for the account of this activity in Genesis gives no indication of *when* this activity began. The Sumerian version indicates when: it was present almost from the beginning of the human race. And as for the giants themselves, we have already speculated that the inhabitants of the planet Tiamat, if such there were, may have been physiologically much larger than mankind’s average size, given Tiamat’s much higher gravity.

Moreover, there is an odd corroboration of the tradition of chimerical offspring of such unions from yet another source, and this is the traditional depiction of Enki, who is sometimes “shown with the legs of a goat complete with cloven hooves, whilst his upper body is clothed in the scales of a fish.”⁵⁵⁹ He is a “goatfish,” a Capricorn. Enki himself, in other words, is a chimerical being, who in turn, as a “son of God” in the Biblical perspective, sires similar chimerical offspring.

However, there is a *second* connection between the Sumerian and Biblical versions, for in the

account of the destruction of Tiamat in the *Enuma Elish*, her creation of chimerical biological life-forms as *weapons* appears to be one principal reason she incurred the wrath of the rest of the gods, in addition to her theft of the Tablets of Destinies. In the Biblical version, the story of the Nephilim and their hybrid-giant offspring forms the immediate context for the divine decision to wipe out mankind for his wickedness. The clear implication is, once again, that it was the continued co-habitation of man and “the sons of God” that formed a motivation for the Deluge. These points suggest a further speculation: could the creation of mankind in the Sumerian version be related to the cosmic war and the theft of the Tablets of Destinies?

Whatever the answer to that question may be, one thing seems to be strongly implied by all that has preceded, and that is that according to the Sumerian tradition mankind appears to be centrally connected both to the motivations of the cosmic war and is to an extent also a legacy of it, at least in the hybridized Nephilimic line. In the Sumerian version, it is human overpopulation that formed one of the motivations for the war, and in the Biblical version, it is the “Nephilimic wickedness” that forms the backdrop of the divine decision to wipe out “mankind” by means of the Deluge. Putting two and two together, it would appear that it is the Enki-Eve line that may have been the focus of attention here, both as a chimerical ultra-hybridized lineage, and perhaps as an overly-populated one vis-à-vis the “pure human lineage” of Adam and Eve themselves. Indeed, we may be drawing near to one reason why the various books of the Old Testament place such an emphasis on preserving various genealogical records, for as an examination of those records will demonstrate, there is little if any association of the Old Testament patriarchal lineage with the second “ultra-hybridized” lineage of Enki-Eve. In fact, the converse is true, for from the moment of the Hebrew Exodus from Egypt to the conquest and occupation of Canaan, an endless struggle is waged against the Nephilimic dynasties of surrounding peoples, the story of David and Goliath being the most familiar example. To put it as bluntly and briefly as possible, one legacy of the conflict appears to be an ongoing “struggle between the bloodlines.” Unfortunately, as fascinating as this story is, as it weaves its way through history, it is not a story that can be recounted here, for it would require a book in its own right.

The relationship between Enki and Eve revives an ancient Talmudic tradition in a particular way, for Enki here takes on the principal role of what Genesis describes as being the activities of the Nephilim, of the “sons of God” who married human wives and sired chimerical, giant offspring. In a roundabout way, then, Gardner has confirmed Genesis’ own characterization of the Nephilim, a characterization supported by the Sumerian’s traditional artistic renditions of Enki as a chimerical being.

C. *Ninurta-Nimrod and the Tower of Babel Moment*

Another intriguing Biblical-Sumerian perspective on the events of the cosmic war is provided by the Tower of Babel episode. As will be seen in a moment, this episode also leads back to Egypt, and Osiris, in a very peculiar fashion. Previous chapters have mentioned the close association of the Anunnaki god Ninurta with the Biblical figure of Nimrod. Any comparison of the Sumerian genealogy of Ninurta with the Biblical genealogy of Nimrod in Genesis 10 will demonstrate there is little if any parallel between the two. So why associate the two?

Beyond the prosaic level of the fact that Ninurta's temple was centered at Nimrud in modern day Iraq, there are other much more suggestive themes that link the two. For example, one of Ninurta's titles that Gardner's genealogical chart clearly highlights is his title of "The Mighty Hunter," a title associated in turn with Ninurta's defeat of (An)Zu. It is, in other words, a title deliberately and directly associated with the cosmic war and the theft and recovery of the Tablets of Destinies, with their universal-power bestowing properties. As Assyriologist Stephanie Dalley notes, Ninurta is the avenger and champion of Enlil and the leader of the Anunnaki in that phase of the war that concerned itself with the second theft of the Tablets.⁵⁶⁰ It is with this tapestry of concepts and titles associated with Ninurta that one finds the resemblance to the Biblical figure of Nimrod.

Nimrod is mentioned only very briefly in the Old Testament, in Genesis 8: 8-10. The context here is significant, for Genesis 8 forms one part in the total "Flood" context that begins with chapter 6 and ends with the Tower of Babel moment in chapter 11. At this point, it is worth quoting what Genesis 8:8-10 has to say about him:

8. And Cush begat Nimrod: he began to be a mighty one in the earth.
9. He was a *mighty hunter* before the LORD: wherefore it is said, Even as Nimrod the mighty hunter before the LORD.
10. And the beginning of his kingdom was Babel, and Erech, and Accad, and Calneh, in the land of Shinar.⁵⁶¹

Thus Nimrod shares with Ninurta the distinctive title of "Mighty Hunter." And in the biblical version it is clear that Nimrod is given this title because he is a conqueror, indeed, the very first conqueror-despot mentioned in the Bible. In this he closely parallels Ninurta, who obtained his title of Mighty Hunter for similarly warlike reasons.

It is also interesting to note the context in which these verses occur within chapter ten, for the entirety of the rest of the chapter is nothing but a record of "the generations of the sons of Noah (v. 1)." In other words, the usual succession of "begats" is interrupted momentarily to provide a small commentary on the enigmatic figure of Nimrod, and then the text resumes for twenty-one more verses of "begats", whereupon the chapter ends, and the eleventh chapter begins. And this is significant, for the eleventh chapter of Genesis begins immediately with the story of the Tower of Babel in verses 1-9. Now note what Gen 8:10 says about Nimrod's kingdom: it began in Babel. This strongly suggests that the biblical account intends for the reader to associate Nimrod with the Tower of Babel moment.

Now let us recall - once again - what I said in my book *The Giza Death Star Destroyed* about the Tower of Babel moment.

1. *The Genesis Account*

“There is another event that bears mentioning with regard to the decline of the paleoancient Very High Civilization and its presumably unified physics and sophisticated technology: the Tower of Babel. The Old Testament affords a significant clue into the event that transformed the unified and paleoancient Very High Civilization into a multitude of squabbling and declined legacy cultures that resulted from it. The story is recounted in Genesis 11: 1-9:

1. And the whole earth was of one language and of one speech.
2. And it came to pass, as they journeyed from the east, that they found a plain in the land of Shinar; and they dwelt with there.
3. And they said one to another, Go to, let us make brick, and burn them throughly. And they had brick for stone, and slime had they for mortar.
4. And they said, Go to, let us build us a city and ***a tower, whose top may reach unto heaven;*** and let us make us a name, lest we be scattered abroad upon the face of the whole earth.
5. And the LORD came down to see the city and the tower, which the children of men builded.
6. And the LORD said, ***Behold, the people is one, and they have all one language; and this they begin to do: and now nothing will be restrained from them, which they have imagined to do.***
7. Go to, let us go down, and there confound their language, that they may not understand one another's speech.
8. So the LORD scattered them abroad from thence upon the face of all the earth: and they left off to build the city.
9. Therefore is the name of it called Babel; because the LORD did there confound the language of all the earth: and from thence did the LORD scatter them abroad upon the face of all the earth.^{[562](#)}

“In the context of the broad scenario previously outlined, the “Tower of Babel Moment” permits a further speculation: could the “one language” and “one people” be taken in the broadest sense, not only of one natural human language and one civilization, but of one *language of science*, a *unified science* and physics? And could the “one people” refer not only to that one paleoancient Very High Civilization, but also to the unifying cultural effects that “one language” and unified scientific worldview afforded it? Nothing in the biblical account precludes these possibilities, and indeed, there is a strong indication that the Tower may be the Pyramid itself, if one understands the “top which reaches to heaven” to be a metaphor of the Pyramid’s many dimensional analogs of local celestial mechanics. By a similar line of reasoning, a unified physics and science is implied in the divine observation that “nothing will be restrained from them, which they have imagined to do.” Clearly, the “Tower” was no Renaissance painting of vast brickwork straining to reach skyscraper heights with wooden scaffolding and cranes groaning to lift massive weights to enormous heights. Something else entirely was at work. In this context, it might not be going too far to speculate that the

destruction of the Tower of Babel may refer, in oblique terms, to the destruction of “the Great Affliction” and “Weapon,” the Great Pyramid.”

And thus I wrote in *The Giza Death Star Destroyed*.

But we now have new data that forms part of the paleophysical context from which to view the Tower of Babel moment, and these are the Tablets of Destinies, which as we have seen throughout the previous chapters, not only conveyed a universal power to their possessors, but their power - as we have theorized - was based on the fact that they were catalogues of the holographic interferometric “gratings” of objects in local space, inclusive of the emotional states of conscious beings. Recalling also that R.A. Boulay stated that the Tablets or MEs were a kind of “instruction manual” or software to a technology of some sort, then it stands to reason that one way to interfere with or to destroy a project designed to build - or rebuild - an “ekur,” “tower” or “pyramid” that utilized the Tablets in a hegemony-bestowing way was to render the “software” inoperable by rendering its human interpreters incapable of understanding its “operating language.” It is a classic maneuver in a kind of guerilla warfare.

To put it differently, if Nimrod is associated with Ninurta, then he is associated with the Tablets of Destinies, and this in turn means that the Biblical account of the Tower of Babel may be yet another chapter in the saga of the Tablets and the Story of the Stones.

2. *The Sumerian Tower of Babel*

But Nimrod is also associated with..*Enki*. In the Sumerian version of the Tower of Babel, known as *Enmerkar and the Lord of Aratta*, composed ca. 2000 BC and thus in all likelihood older than the Genesis version of the story, the “whole world, the people as one, to Enlil in one tongue gave voice.”⁵⁶³ Then enters a peculiar character, En, or Enki:

Then did the contender - the en (lord)

The contender - the master

The contender - the king

The contender - the en

The contender - the master

The contender - the king

Enki, en of hegal,

The one with the unfailing words,

En of cunning, the shrewd one of the land,

Sage of the gods, gifted in thinking,

The en of Eridu,

Change the speech of their mouths,

He having set up contention in it,

In the human speech that had been one.⁵⁶⁴

Nimrod in the Sumerian version of the story is represented by the character Enmerkar. Now note that in the Hebrew, with its consonantal alphabet, the name Nimrod would be represented n-m-r-d. In Sumerian, the character Enmerkar is simply Enmer, to which the suffix “kar,” meaning “hunter”, has been added. Enmer would be consonantly represented as n-m-r.⁵⁶⁵

The parallels do not stop there.

The Sumerian Kings List, to which reference has already been made in this book, states that Enmerkar also constructed Uruk. In Genesis, the center of Nimrod’s kingdom was Babel or Babylon and Erech, which is another name for Uruk. Here too there is reason to believe the Biblical text, given its antiquity, might not refer to Babel or Babylon, but to Eridu, the cult headquarters for Enki. This headquarters was known as the “nun-ki” or “mighty place,” a title that was only bestowed on Babylon some one thousand years later with the temple to Marduk that was dedicated there, where it was known as the “bab-ilu”, its Akkadian name. “In other words, *Bab-ilu* equates to *Nun.ki*, and the original *Nun.ki* was located not in Babylon, but in Eridu.”⁵⁶⁶ Archaeology would appear to support this idea, since there is an impressive ziggurat that was unearthed in the 1940s at the ancient site of Eridu. More importantly, the excavators discovered that at the highest point of this massive ziggurat, the entire settlement was entirely and suddenly abandoned.⁵⁶⁷

This surely seems as far from Egypt, Giza, and Osiris as one can get.

However, the picture is not quite that simple, for the name Osiris itself was hieroglyphically written as the sigil for a throne, followed by that of an *eye*, but the order was subsequently reversed. The Egyptian form of Orisis, *Ausar*, is a cognate of the Mesopotamian *Ashur*, and implies someone who possesses his throne. Other meanings are “The seat that creates” and “The seat of the eye,” and “the Mighty one.,”⁵⁶⁸ The connections with the “Sound Eye” of the Edfu texts and with the title of Nimrod in Genesis are now apparent. The revisionist scholar David Rohl explains this constellation of symbols — Osiris, Nimrod, Eridu-Babel, and the Tower of Babel — this way:

It appears that we are dealing here with a single historical character who established the first empire on Earth and who was deified by many nations under four main groupings:

- (1) Early Sumerian Enmer, later Mesopotamian Ninurta, ...biblical Nimrod, Greek Ninus;
- (2) Old Babylonian Marduk, biblical Merodach, later simply known as Bel of Baal(“Lord”);
- (3) Late Sumerian Asar-luhi...Assyrian Ashur, Egyptian Asar (Osiris);
- (4) Sumerian Dumuzi, biblical Tammuz, Phoenician Adonis, Greek Dionysius, Roman Bacchus...⁵⁶⁹

If this identification proves true, then the connection of the Tower of Babel not only with Eridu but also with Giza, which I first speculated upon in my *Giza Death Star Destroyed*,⁵⁷⁰ appears even more solid, for now the connections are between Osiris, Nimrod, and Osiris’ resting place in the “Rostau” or Underworld of Giza.

We are in the presence, once again, of the richly punning, multilayered levels of meaning of the Unified Intention of Symbol, for there are now numerous connections between Giza, the wars of the Gods, Mars, the Tower of Babel moment, and mankind itself. And as the previous chapters have also detailed, we are likewise in the presence of texts that preserve a dim, though still very discernible pattern of the technology that was associated with those wars and indeed, in some accounts, was their cause. And there is one more connection that must now be mentioned. Enki, in the Greek tradition, is one and the same as *Chronos*, or *Saturn*.⁵⁷¹ So again, one encounters that peculiar association of Mars and Saturn in this cosmic conflict, an association first observed by De Santillana and Von Dechind.

At this juncture, after many chapters and pages of analysis of texts and of science, with some linguistic and etymological excursions along the way, we are in the presence of a complex of intricately interlocking symbols and motifs all in aid of the exposition of a very simple theme: a cosmic war, fought on many worlds, with advanced technology, a technology involving stones, Tablets of Destinies, mountains, and “sound-eyes.” The worlds with which we are concerned are indicated by the “gods” hitherto discussed, and their associated planets:

Mars	Nergal, and in some instances, Horus
Saturn	Enki
The Moon	Thoth
The Sun	Marduk-Ra
Jupiter	Marduk.
Earth	All of the above.

We have but to look for anomalous features of artificiality, and of warfare, on these planets or their associated satellites, for external confirmation of the war hypothesis, for a prima facie case has already been made that there was once a physics sufficient to weaponize to explode a planet in an act of war, and moreover, a physics whose outlines are clearly visible, though a dim memory, in the ancient texts.

A “catalogue of clues” is now in order, by way of the exposition of certain chronological features of the scenario alluded to throughout this work, and by way of an exposition of the timing of the fall of one of the most sinister, malevolent, and genocidal and “globalcidal” figures of all in this cosmic drama of war, subterfuge, and extremes of technology: Lucifer, Ra the “sun-god” and “light-bearer.”

A CATALOGUE OF CLUES: A REVIEW OF THE WAR

*“Logic suggests (and I believe the facts bear this out) that there have been not one but **two** rebellions against God: One that occurred before the Genesis account of the formation of the earth and another that caused the fall of mankind...”*

Stephen Quayle [572](#)

The chronological framework of the cosmic war has been alluded to throughout this work, but it is now time to explore it further, in conjunction with new clues not only into the war's participants, but also in conjunction with its phases and locations. In the process, a “catalogue of clues” will be assembled that will guide the quest for external confirming evidences in the next part of this book.

A. *Primordial Revolts and Wars: Sumer, Edfu, and the Genesis “Gap” Theory*

As was seen in previous chapters, there are two “primordial revolts and wars,” that referred to in the Edfu texts from Egypt, and that referred to in the *Enuma Elish* and other texts from Mesopotamia. There is a third major tradition from that world that must now be examined, for it moves between Mesopotamia and Egypt throughout its history, and that is the Hebrew tradition of the Old Testament and other writings.

But its movement within this mytho-cultural matrix is scarcely appreciated for what it is: a variation on the broad theme of the cosmic war. The subject is, of course, the Fall of Lucifer. Unfortunately however, both “believers” and “skeptics” know this only in basic “Sunday school” version and thus only in its broad outlines, but neither of these two polarities tends to view the angelic revolt and fall against this broader mythological and cultural context, and some would be positively disinclined to do so, for ill-conceived “theological” reasons. Nonetheless, it is important to do so, since the Fall of Lucifer provides yet a third corroboration of the idea of a primordial revolt and war in the pantheon.

This event is usually best examined in conjunction with another theory, the so-called “gap” theory of creation, for in this theory, the Fall of Lucifer is usually understood to have occurred *prior* to the creation of mankind.⁵⁷³ A hint of the possibility of a pre-existent civilization on the earth prior to the creation of mankind may be found in Jeremiah 4:23-26:

23 I beheld the earth, and lo, it was without form, and void; and the heavens, and they had no light.

24 I beheld the mountains, and, lo, they trembled, and all the hills moved lightly.

25 I beheld, and, lo, there was no man, and all the birds of the heavens were fled.

26 I beheld, and, lo, the fruitful place was a wilderness, and all the cities thereof were broken down at the presence of the LORD, and by his fierce anger.

The fact that this passage uses the same phrase, “without form and void” to describe conditions suggests that the time frame involved is that described in Genesis 1:1. Yet, as Stephen Quayle points out, there are three indicators that, while the time-frame of Genesis 1:1 is more or less in mind, there is also a civilization in existence:

- Birds were present. This suggests that the previous creation had elements similar to today’s...
- The pre-Adamic land was “fruitful” and therefore had vegetation that supplied abundant food.
- There were ancient cities that pre-dated Adam, which were “broken down” by God’s wrath.⁵⁷⁴

In other words, the Old Testament itself strongly suggests the idea of a pre-cursor, pre-human civilization on the earth. Moreover, it strongly hints that the reason for its collapse was some sort of war.

But what of Genesis itself?

The usual translation of Genesis 1:1 has always been “*In the beginning*, God created the heavens and the earth.” But as many biblical scholars have not tired of pointing out, the Hebrew language’s verb system and other peculiarities of its grammar would also permit the translation *When God began to create* the heavens and the earth,” and then the second verse would immediately follow, “the earth was without form, and void...” and so on. This way of translating the verse, and viewing it in conjunction with the passage from Jeremiah quoted above, led to the formation by some theologians and commentators of the “Gap Theory.” This theory holds that there was an initial creation by God, that Lucifer and his hosts subsequently fell, and corrupted this original creation. In some versions of the theory, Lucifer and his hosts fell almost immediately after the initial creation, a view that would corroborate the Edfu texts’ notion of a primordial fall, a fall and conflict that occurs just as the transmutative aether is being fashioned by the gods into a recognizable world.

In any case, the Gap Theory holds that after this angelic fall, the “war in heaven” between Lucifer and his fallen angels, and Michael the Archangel and the heavenly hosts, occurred, wreaking havoc on creation itself. Thus, a “second creation” was brought about by God, this time not out of nothingness, but rather to “repair” the damage, so to speak, caused by that war. Like the Sumerian tradition, this war even has Lucifer and his hosts falling to the earth from the sky.

Author Stephen Quayle interprets this theory against the twin backdrops of the planetary anomalies on Mars and elsewhere, and against the backdrop of catastrophism:

Exactly how the ancient Earth became “without form and void” is hard to say. But there are several events that appear to have taken place which would have done the job, and thus, might have been employed by God to wipe the face of the Earth clean. Interestingly, both of these had the capacity to throw up massive amounts of sort and ash, thereby blocking the light from the planet, as is suggested by the “darkness on the face of the earth.”

The method, of course, is

The most likely ‘suspect’ ... one or more comets... [575](#)

Mars and other planets show the evidence of massive meteoric bombardments of their surfaces. [576](#)

As has been seen, however, a scalar weapons technology would also certainly be capable of manipulating weather, blacking out the light of the sun, and causing plasma- and explosion-generated craters on other celestial bodies. In any case, as Quayle points out, “Since Mars and other planets, as well as the planet-sized moons of Jupiter and Saturn also exhibit this destruction, one might also speculate that these worlds and moons might also have been inhabited by angels, or even space-faring giants.” [577](#)

Regardless of whether or not one accepts Quayle’s interpretation in its narrow biblical application, it is clear that it *does* fit the wider Mesopotamian and Egyptian context that we have examined in conjunction with the Sumerian and Edfu texts, and in that context the biblical “war in heaven” would appear to be another version of the great cosmic war in the pantheon those texts describe.

1. A Chronological Outline Emerges

Putting these observations together with Van Flandern's Multiple Exploded Planet Hypothesis, the Sumerian *Enuma Elish*, and the Edfu texts, one has a "primordial revolt" occurring somewhere between shortly after the initial creation and 65,000,000 years ago, with the explosion of the large planet in the asteroid belt, with the resulting evidence of a massive catastrophe that occurred at approximately that time that exists in the K/T geological boundary layer.

After this, a "second creation" occurs which repairs the damage. It is important to note that both the "Gap Theory" and the Edfu building texts, with their emphasis on the creation of a second "island" at the Rostau, both maintain more or less the same sequence of events.

Following this, there is a period in which there is a civilization that appears to exist on Mars, the Earth, and possibly the Moon, and then a second, smaller planetary explosion ca. 3,200,000 years ago, according to Van Flandern. This event, it will be recalled, did not leave sufficient geological evidence of its occurrence on the earth, and thus Van Flandern was led to modify his initial theory and to posit that it was the explosion of a much smaller celestial body. But as will be recalled, I posited an alternative explanation for the relative absence of such a layer as the K/T layer for this event, and that was that it may be possible that this more recent event occurred when the exploding planet, and the earth, were at their farthest distance from each other. In this case, such damage as would be recorded in the geological data would be of a more random and sporadic nature, as the earth subsequently moved through the "debris" field of this explosion.

Another point should be observed, and that is the presence within the Great Pyramid's remaining limestone, of small fossils dating to about 5,000,000 years ago. This would tend to indicate the very remote possibility that, while not built in time for the 65,000,000 years event, it may have been very remotely possible for it to have been built in time for the event at 3,200,000 years ago. However, most of the other chronological data concerning the Pyramid would definitely exclude this possibility, since they indicate the structure is only thousands of years old, and possibly pre-dates the Flood event at 10,500 BC, by some unknown number of years.

Sometime after this second planetary explosion, we have the possibility of a third event, the "Flood event" ca. 10,500 -15,000 years ago.

As noted previously, the explosion of a large water-bearing Saturn-sized planetary mass, which may have been home to intelligent life, would have had two possible confirmations: (1) such life would likely have been, by human standards, of very large, or "gigantic" stature; and (2) the explosion of a water-bearing planet of that size would have concussed its nearest neighbor, Mars, with a shock wave of water and debris that would have scoured the hemisphere of that planet that faced the exploding planet, and inundated the other hemisphere with a truly planet-wide deluge. This shock wave would have reached the earth in a dissipated form, causing similar wide-spread planetary damage.

In any case, viewing the texts in this light against the backdrop of Van Flandern's Multiple Exploded Planet Hypothesis highlights one fact about the cosmic war, if one ascribes *both* planetary explosions to that war, and that is, the war was *cosmic* not *only in its* breadth in *space* but *for its*

duration in time.

This scenario would also imply the following types of corroborating evidence:

1. The presence of anomalous features on the planets Mars, and the Moons of Jupiter and Saturn suggesting an artificial origin since the texts as studied in pervious chapters indicate the involvement of these planets in the war and its resulting destruction;
2. The presence of anomalous features on the Earth's Moon suggesting a similar artificial origin;
3. Moreover, these features, if their artificial nature is established, should in turn indicate a common *cultural origin* and technology, i.e., they should be *similar in appearance*;
4. Following the suggestions of the Mesopotamian and Biblical traditions, there should be evidence of the chimerical, giant offspring of the unions of the "gods" and humans, a point already explored in chapter four;
5. There should also be evidence of the antiquity of mankind on earth prior to the standard theories of human origins, and/or evidence of the presence of intelligent life on earth in great antiquity;
6. There should be evidence of the existence of a weaponizable physics capable of wreaking planetary-wide damage and of destroying a planet in its entirety, a point which has already been argued; and finally,
7. There should be evidence of *intentional destruction* on the surfaces of the above planets, or at the minimum, evidence of anomalous patterns of destruction on those planets.

This list does not change significantly if one takes the alternative dates of the scenario, based on the event of 3,200,000 years ago being the main event. If, however, one takes my suggestion that the event at 3,200,000 years ago was the main event, as Van Flenden himself initially proposed, and that a K/T-like boundary layer is missing from the earth simply due to its distance from that explosion, then the above chronology is modified accordingly. In this case, while the celestial mechanics become much more improbable, the scenario would seem to square with the chronology suggested by the mythological texts which *always seem to imply human observers to the events*, and early mankind begins to emerge circa this time frame according to the standard theories.

Either way one wishes to view the chronological problem, however, one thing should now be abundantly clear, and that is that the ancient traditions of a cosmic war and the implications of the Multiple Exploded Planet Hypothesis fit together with enough exactitude to allow this set of corroborative evidence to be constructed. The likelihood of the cosmic war hypothesis consequently increases with the fulfillment of each of the seven above criteria of corroborative evidences.

But one serious question remains.

2. Angels and Plasma Life?

This serious question is the clear implication found in the Mesopotamian, the Egyptian (Edfu), and the Biblical traditions that the “gods” are “spirits”, i.e., incorporeal and non-material in nature. They are, in short, a very *different* form of intelligent life than the humanoid “giants,” Nephilim, and humans themselves, that we have discussed thus far. And as I have observed elsewhere,⁵⁷⁸ the problem is compounded by the fact that in the Mesopotamian and Biblical traditions, these “gods” or “sons of God” marry humans and sire chimerical offspring from them.

Traditionally, Christian theology has maintained that the angels, and by implication demons, are beings of “light” and thus not inhibited by the normal constraints of space and time. They are, so to speak, a sort of “hyper-dimensional” life form able to “slow down” long enough to manifest themselves corporeally, materially, and locally, and thus presumably, to sire offspring of humans.⁵⁷⁹ This whole approach has often been sarcastically portrayed in the popular imagination as a debate on “how many angels can fit on the head of a pin,” when in fact its profound character as a speculation in *theoretical physics and its implications for alternative life forms* has gone entirely unnoticed.

But the theological conjectures of an earlier age might not be so easily dismissed. In fact, they find rather strange corroboration from the plasma physics community, for the famous quantum and plasma physicist David Bohm once noted that the behavior of electrons in plasma gave him the impression that they were somehow alive, since they exhibited the kind of self-organizing properties in plasma that one normally associated with life. More recently, an even more suggestive connection between plasmas and life appeared to have been demonstrated by physicists who were able to create plasmas that *grew, replicated, and communicated information to each other*.⁵⁸⁰ This fulfills three out of the four main criteria that many list for the presence of life. The major distinction between such plasmas and ordinary life is that *ordinary life requires the presence of inherited material from the parent to the child*. This is eerily reminiscent of the statement by Christ in the New Testament that angels neither marry nor are given in marriage. One is permitted to speculate that perhaps plasmas are able to communicate or imprint information almost totally on another plasma. By implication, this would enable them to do so in any interface with more organically based life. In the case of the evil intentions of “fallen angelic ‘plasmas’” this would manifest itself as an habitual inclination toward evil, recalling our speculations concerning an impressed dynamic of evil on the Tablets of Destinies, explaining their consistent and persistent association in the texts with the cosmic war in the pantheon.⁵⁸¹

B. More Miscellaneous Clues:

1. Serpent Gods and Dragon People

Lucifer is, of course, usually understood by the Judeo-Christian tradition to be the serpent referred to in the Genesis three account of the fall of man. His description as the “wisest” and “most cunning” of all the creatures - as well as his promise to mankind that if it but eats of the “forbidden fruit” of the tree of the knowledge of good and evil - has led some commentators to draw parallels between him and the “civilizing” and “wisdom” gods of other cultures, the gods who taught mankind the arts and sciences of civilization. The Mayan-Aztec god Quetzlcoatl, who is credited with teaching them their civilization, is said to have been a bearded white man, but is also, as is well-known, depicted as a “feathered serpent” or a “winged serpent.” Similarly the Incan Viracocha was a bearded white man, and also a “feathered” or “winged” serpent. The Egyptian “wisdom god” Thoth, who is also credited with building the Great Pyramid, is also associated with a lizard, the salamander. Even the book of Revelation refers to Lucifer as a “dragon” or, to put it differently, a “feathered serpent.”⁵⁸²

In ancient Egypt’s mythology the flying serpent is not only a symbol of immortality, it is also an ambiguous symbol both of the source of good and of evil, a dialectic recalling the serpent’s temptation of mankind in Genesis three to eat of the tree of the knowledge of good and evil. Not surprisingly, these feathered serpents or dragons are also said to have sired a chimerical offspring with mankind.

The *Book of Dzyan*...(states that) the Sarpa or Great Dragons were the Fifth Race to inhabit the world. The Fourth Race was a race of giants who had lived before the Deluge but were wiped out by that catastrophe. The book relates how the serpent gods or dragons redescended after the Deluge and instructed man in the arts of civilization. These serpent-gods had a human face and the tail of a dragon: they founded divine dynasties on Earth and are believed to be the ancestors of our current civilization, the Fifth Race of the *Book of Dzyan*. The leader of these gods was called “The Great Dragon.”⁵⁸³

Like the giant offspring of the Nephilim described in the Old Testament, the *Book of Dzyan* also describes the “reptilian-human” offspring of this fifth race as practicing cannibalism.⁵⁸⁴

Egyptian art often depicts the slaying of an evil serpent in terms starkly reminiscent of the Christian theme of St. George slaying the dragon.

*Egyptian Winged Serpent Motifs*⁵⁸⁵



*Egyptian Slaying of the Serpent Motifs*⁵⁸⁶



The Egyptians also depicted “serpent vehicles” in the Pyramid texts, carrying Osiris in the underworld in a “boat” and then to the stars.

*Egyptian “Serpent Vehicles” Carrying Osiris, from the Pyramid Texts*⁵⁸⁷



These feathered or flying serpents and dragons are also associated with the notion of kingship itself, appearing in the Egyptian pharaoh's headdress or ureaus.⁵⁸⁸ Similarly, the ancient Emperors of China claimed descent from the "Celestial Dragon," since dragons were "present at the Creation and shared the world with mankind." Moreover, in China "the dragon was linked with the development of man" and who "taught him the essential arts." Indeed, "the first humans were believed to have been created by an ancient goddess...who was herself part dragon and part mortal."⁵⁸⁹

2. *Dragon Treasures*

Another strange connection of dragons with this unfolding story is the motif that one often associates with dragons: their underground existence, guarding hordes of treasure and precious gems. So pervasive is this theme in the lore of dragons from around the world that it compels an obvious question.

Gems have a central theme in the legends of dragons. They had a compulsion to hide and protect these precious stones. Sometimes the possession and protection of these jewels was the all-encompassing purpose of existence. Were these “stones” the “power crystals” of the Sumerians which gave extraordinary power to the owner?⁵⁹⁰

Given the fact that there are so many other persistent motifs that connect these various legends, from Nephilim and Anunnaki to “dragon” or “serpent gods” and their chimerical offspring, to Lucifer the “serpent” lost stone of power, the *lapis exilis*, one would have to answer this with a tentative yes.

We may now assemble the “catalogue of clues.”

C. Summary: A Catalogue of Clues

A broad mythological context has now been assembled from which to view the cosmic war that, when viewed with the evidences presented in part one, constitute a *prima facie* case that this war was *literal and real* and *not* merely a metaphor for the explosions of planets brought about by collisions between celestial bodies, as various schools of catastrophism would have it. Among these the following points should be stressed:

1. The broad outlines of this war involved the planetary systems of the Earth-Moon, Mars (and by implication its satellites Phobos and Deimos), Jupiter and its satellites; Saturn and its satellites the now missing and exploded planet(s) and its satellite, which was probably Mars, and the Sun itself.
2. This hints at the existence of a civilization based at least in part on those worlds, and, if one takes LaViolette's Pulsar hypothesis into view, based elsewhere in the galaxy as well.
3. This civilization is suggested by the associations of the following gods with the various celestial bodies under consideration:
 - a. Mars and satellites with Nergal, and possibly Ra and Thoth and other wisdom gods, since there are indications of serpent-reptile themes in association with Mars. The war is one of rebellion, and this associates well with the characters of Nergal, Lucifer, Enki, (An)Zu and others from various traditions;
 - b. The Moon with Thoth and other "Moon gods";
 - c. The Sun with Ra-Marduk and other "sun gods;"
 - d. The missing planet, "Tiamat" or Krypton, with a primordial rebellion;
 - e. Saturn with Chronos from Greek mythology, and therefore with the wars against the Titans or Giants;
 - f. The close association of Saturn and Mars, as observed by De Santillana and Von Dechind;
 - g. Jupiter with Marduk in some versions.
4. As noted in part one, the recent images of the Cydonia "Face" are not only capable of the dual-aspect and Sphinx-like interpretation first suggested by Richard Hoagland in conjunction with the Viking images of the object, but are even more suggestive of these characteristics, and not less so. As was seen, one aspect depicts a humanoid-like face complete with a "gemstone" or "serpent-like" feature in the Mars Face's "headdress" reminiscent of the pharaonic uraeus' serpent motif, and consistent with the "stones of power" motif from Sumerian texts and the "stone of exile" associated with Lucifer's crown in the Judeo-Christian tradition.

As a result of this constellation of relationships, we may observe that the war appears to have been, at the minimum, between the following parts of this ancient civilization: on the one hand, Mars, the

missing planet “Tiamat” or Krypton, and possibly some areas of the Moon and the Earth; and on the other hand, Jupiter, Saturn, their satellites, the Sun, and parts of the Moon and the Earth on the other. Earth and the Moon would, therefore, appear to be divided between the two factions, and thus possibly be one point of contention between them, and perhaps even the central point.

From this reading of the scenario, then, the “Flood” itself appears to be yet another example of the “Unified Intention of Symbol,” since *many* such planetary- and regional-wide floods appear to be in view: (1) the Flood on Mars that resulted from the explosion of “Tiamat-Krypton” and, as the shock wave traveled further, similar damage to Earth; (2) subsequently the regional floods that recurred periodically on the Earth. The same would apply for the “Noah motif found especially in Sumerian and biblical literature. However, an interesting distinction between the two should be noted.

It is often pointed out by biblical scholars and Sumerologists that there is a clear similarity between the biblical story of Noah and that of the Sumerian flood epic and its heroes Utnapishtim and Gilgamesh. But there is an important distinction that might indicate that these two stories are referring to *different* floods: the Sumerian account clearly contains a reference to its heroes being able to view the entire Earth from a point in space above it, and this implies a space-faring technology. Thus, the Sumerian account might be referencing a “Noah” episode that concerns a planet *other than the Earth*, one that was concussed by a sudden planet-wide flood. The best candidate, of course, is Mars. The Biblical account, conversely, is squarely set on the Earth exclusively. While there are similarities in the accounts, therefore, it is my belief that they refer to separate events, or perhaps to a *Space/Mars-based frame of reference as distinct from an Earth-based frame of reference for the same event*. One might, in this case also, be in the presence once again of the Unified Intention of Symbol. In either case, if one is positing a sophisticated ancient society of this interplanetary nature, with a physics sufficient to fight a war and wreak destruction on a planetary scale, one is also positing a civilization with a sophistication sufficient to the genetic manipulations suggested by those same texts. In this light, the “ark” would appear to be less a boat packed with adult animals, than it would a container of DNA samples.

With these ideas in mind, we may now turn our attention to the planets themselves, seeking confirming clues that they may once have been the homes of a long-lost, advanced civilization, and the battlefields of a very ancient, cosmic war.

PART THREE:

EXTERNAL EVIDENCES: THE EARTH, THE MOON, MARS, AND SATURN

“Cremo and Thompson ’s central proposition is that the model of human prehistory, carefully built-up by scholars over the past two centuries, is sadly and completely wrong. Moreover, the authors are not proposing that it can be put right with minor tinkering and adjustments. What is needed is for the existing model to be thrown out the window and for us to start again with open minds and with absolutely no preconceptions at all. ”

Graham Hancock, from the Foreword to Michael A. Cremo’s and Richard L. Thompson’s *The Hidden History of the Human Race*, p. xiii.

THE MYSTERIOUS MOON

“Earth not only has a satellite, but it is a giant satellite, 2,160 miles in diameter. Amazing.”

*Isaac Asimov*⁵⁹¹

“The Moon is the only thing that gives me a headache.”

Sir Isaac Newton

In order to corroborate the scenario of cosmic war suggested by the ancient traditions, it is necessary to examine the planetary systems on which it was alleged to occur or with which it was connected, for corroborative evidence. This evidence would of necessity have to be artifacts suggesting an artificial, intelligent origin, implying a civilization to construct it. Moreover, this evidence would also of necessity have to suggest the type of destruction associated with a war, and with the types of scalar, plasma, and nuclear types of weapons that those texts suggest.

Our focus here is, obviously, the Moon. Many people state that they have never seen a UFO. But, as we shall see, one of the most *unexplained* “flying objects” in the skies over our heads is precisely the Moon. It is, in a way, the largest, most obvious flying saucer, and by the same token it is therefore also the largest, most blatant challenge to the assumptions of “normal science” and the various paradigms of explanation and the models it engenders, for almost nothing about the Moon makes any sense if viewed from the standpoint of those very same paradigms and models. Our concentration will be on five principle areas of data: (1) How did it Get There? (2) LTPs, or Lunar Transien Phenomena, (3) Shards, Cuspids, and Towers versus “Incessant Meteoric Bombardment,” (4) its ability to “ring like a bell” and its implications, and finally (5) Strange Possibilities of Deliberate Destruction.

A. How Did It Get There?

The most obvious difficulty that the Moon presents is simply its *presence*, since by any reckoning it is just too massive for such a small parent planet as the Earth. This has prompted a variety of models to explain its origin, which may be reduced to two broad theories: the “planetary fission” model and the “capture” model.

1. The Planetary Fission Model

One theory, favored in the pre-Apollo era, was that the Moon and the Earth “fissioned” or split apart in the early years of the planets’ formation, with the Moon emerging from what is now the Pacific basin, and settling into its current orbit. This would entail enormous difficulties of celestial mechanics that simply pile up too many coincidences. For example, the Moon exists in a nearly perfect circular orbit around the Earth, an orbit that, moreover, allows only about 60% of the Moon’s surface — the same side — to be visible from the Earth, even though the Moon, like the Earth, rotates around its own axis. Additionally, the Moon exists at the precise distance from the Earth that allows it to totally eclipse the Sun. A “fission” model would, moreover, imply that the Moon’s orbital mechanics around the Earth would of necessity be rather more elliptical than they are.

But there is a final difficulty, one that proved fatal to the “fission” model after the first Apollo Moon landings returned with rocks from our celestial neighbor. For the fission model to be true, the age of rocks on the Moon would have to be of similar antiquity to the Earth itself, yet rocks and soil were discovered on the Moon that were some *billions* of years older. The oldest rocks found on Earth are some 3.7 billions of years old, while rocks returned from the Apollo missions dated from 4.3 to 4.6 billions of years old, while one rock even dated to some 5.3 billions of years old. This fact is made the more curious because the area of the Moon from whence they originated was thought to be one of the geologically youngest on that planet!

2. *The Capture Model*

With the death of the “fission” model, scientists were led to posit a “capture” model for its origin. In one version of this theory, the Earth and the Moon evolved into their current double-planet system from the same primordial space dust in the early formative years of the solar system. However, for this model to be true the age of rocks from the two planets would again have to be similar, and here again, the Apollo moon rocks simply exhibited too great of an age disparity for this model to be correct.

This led to the second, and now regnant, theory of “capture” to be adopted. According to this theory, the Moon was “captured” by the Earth’s gravity as it wandered too close, and became a permanent satellite of the Earth.

The problem with this model is, once again, the physics simply does not work, for in addition to piling up all the previously mentioned mechanical “coincidences” a further problem is encountered. This is the idea of “capture” itself, a phenomenon used, in fact, by the Russian and European space agencies, and by NASA itself, in launching deep space probes to the other planets of the solar system. Using another planet’s gravity well, these probes are steered close enough to these planets to “slingshot” them to even more distances. As the probes enter a planet’s gravitational attraction, they *accelerate* and thus slingshot by the planet, able to gain speed for their outward journey.

And so the Moon, if it *was* captured would have to *accelerate* as it entered the gravitational pull of the Earth, and this in turn would inevitably have led to an elongated and elliptical orbit. But this is not what millennia of observations have shown. Since the Moon is apparently older than the Earth, it stands to reason that the capture model is correct in its basic outline. However, no known mechanism can account for its current orbital mechanics. In short, it would appear that the Moon had to have been “braked” as it entered Earth orbit, and in such a fashion as to assume its current position. As no known naturalist mechanism exists to explain such “braking,” the only other explanation would appear that it had been intelligently guided to its current position. It is a celestial mechanics analogue to parallel parking a car.

Briefly stated, the Moon was *parked*. And that implies a *pilot*.

This catalogue of facts led two Soviet scientists to propose in the 1970s for the Soviet magazine *Sputnik* that the Moon was, in fact, a gigantic artificial spaceship. But there were other anomalies about the Moon, first revealed during the initial days of the space race between the United States and the Soviet Union, and continuing all the way up through the Apollo moon landings.

B. Apollo Anomalies

1. Previous Soviet and American Probes

One of the most interesting aspects of the lunar anomalies is the strange behavior of early Soviet and American unmanned probes to the planet. The Russians were the first to the Moon with an unmanned probe, another first in their long line of early space firsts; Luna 1 reached the Moon on a “fly-by” mission in 1959, coming to within about 4500 miles of the Moon’s surface.

This was followed by Luna 2, which was the first man-made object to actually hit the moon. This probe was not designed to survive the impact on the Moon’s surface. Things suddenly changed, however, with the Luna 3 probe.

Luna 3 was the first man-made satellite to circle around to the far side of the Moon, where it was also the first to take pictures of that side of the Moon. Strangely, and as far as is publicly known, the Soviet Union ceased all lunar exploration for a full four years after Luna 3, and the probe’s pictures were a closely held secret.

Meanwhile, the United States was late getting to the Moon, and its early probes were not very successful. Ranger 3, which was launched in 1962, so completely missed the Moon that it wound up in orbit around the Sun. Ranger 4 struck the Moon, but returned little useful information. Ranger 5 missed the Moon by a whopping 450 miles.

When the Soviet Union revived its lunar exploration in 1964 with Luna 5, the craft crashed into the Moon at full speed when it had been designed for a soft lunar landing. Luna 6 was even less successful, missing the moon completely. Like Luna 5, Luna 7 crashed into the Moon, a result of its retro-rockets having fired too early. This point is highly significant, as will be seen momentarily.

Luna 8 also crashed, but finally the Russians were successful with Luna 9, which was able to soft land on the Moon, the first man-made spacecraft to do so. It is also noteworthy that after Luna 9, both Russian and American success rates of attempts to land probes on the Moon improved.

2. *The Equigravisphere and Other Gravitational Problems*

Why were the early Soviet and American attempts to orbit or land probes on the Moon so unsuccessful? Clearly neither the Russians nor the Americans lacked the mathematical talent to calculate a proper trajectory for spacecraft going to the Moon, *unless there was some hidden problem that made accurate calculations erroneous*. As an example of this problem, many have pointed out that Dr. Werner Von Braun let slip an interesting piece of information after the first successful Apollo landing, in an interview to *Time* magazine in 1969. In the interview, Von Braun revealed that the neutral point for the gravitational attraction between the Earth and the Moon was approximately 43,500 miles from the lunar surface. This was over twenty thousand miles further away from the surface of the Moon if the Moon were only $1/6^{\text{th}}$ of the gravitational attraction of the Earth.

Yet another problem was revealed during these early space probes and the subsequent Apollo missions. Orbiting spacecraft would suddenly “dip” and accelerate over certain very localized areas of the lunar surface, those areas precisely known as the lunar “maria” or “seas,” the dark glassy areas of the Moon found only on the side facing the Earth. These concentrations of heavy mass were called appropriately enough “mascons,” and they could only mean that there was present beneath the lunar surface in these areas dense concentrations of some very heavy matter. Yet, no naturalistic explanation has yet been advanced for these formations that can account for their presence through random processes.

But the final gravitational anomaly may be the most significant one, and that is the anomaly related to the Russian space probe Luna 7’s early firing of its retro-rockets. It was natural for the Russians to assume that the Moon was a solid, homogeneous “rock” floating in space. In these circumstances, retro-rockets may be fired fairly early. But if the Moon were *not* a “solid rock” floating in space, but was either of greatly differing densities of material on its interior, or even worse, *hollow*, then this would change everything. Retro-rockets would have to fire later and burn faster.

The reason is relatively simple. If the Moon was a solid rock, then the center of gravity is farther away from the surface one is landing on, and hence, one may fire retro-rockets earlier, and burned at a slower rate. Conversely, if the Moon is hollow, the center of gravity shifts towards the surface one wishes to land on, and thus one would fire retro-rockets later and burn them faster in order to effect a soft landing. Indeed, in the July 1982 issue of *Atsronautics* magazine, Dr. Gordon McDonald of NASA actually reported that a NASA study of the Moon’s motion revealed that it moved more like a hollow object than a solid one, i.e., that the material in its interior was much less dense than that toward its surface.⁵⁹²

So gravitationally, the Moon is almost completely unlike any other celestial object man has encountered. Even if one does *not* accept the possibility that its gravity might be much more than the $1/6^{\text{th}}$ gravity that prevailed before Von Braun’s significant revelation about the distance of the neutral point between the Earth and the Moon, one is still left with the difficulties of physical mechanics that the Earth should even *have* such a large satellite based on a random “capture” of a passing celestial body, much less have it in precisely the perfectly “circular” orbit that it has. The gravitational problem of such a capture is further enhanced by the presence of the anomalous regions of greater

mass concentrations beneath the maria, the “mascons,” for their presence would make any such “capture” somewhat “wobbly.” And finally, there is the problem of all those early space probes, careening wildly by the Moon, or, retro-rockets firing as if to soft land on a solid rock, and instead crashing straight into it.

This led two Soviet scientists to draw what was by then an obvious, but very uncomfortable, conclusion: the Moon was not a planet in any normal sense at all. It was an artificial body. It was a gigantic spaceship. This idea became, in fact, the subject of a “UFO classic” in the 1970’s in a book by Don Wilson called *Our Mysterious Spaceship Moon*. The book contains a goldmine of details on strange lunar anomalies, and, in spite of its popularity, has never been republished.

In any case, if this “spaceship Moon” hypothesis were ever to be confirmed, however, its relevance to the Cosmic War hypothesis and scenario outlined here is rather obvious, for a civilization in possession of a physics and technology capable of wreaking giant regional scarring on the surfaces of planets, or of exploding one, would likely also be capable of other similarly huge “mega-engineering” projects. But even if, as is much more likely, the Moon is not an artificial body, it still contains sufficient anomalies to suggest that it may once have been an outpost of the civilization that waged that cosmic war. And the problem of how it got there remains.

3. *Mission to Ground Transmissions*

An odd confirmation of this has been the strange radio signals coming from the Moon and its vicinity. In fact, the radio transmissions were not the only strange things man encountered in the beginning years of space exploration. It is well known that Project Mercury astronaut Gordon Cooper never made it a secret that he had spotted a UFO during his Faith 7 Mercury mission. The object was also seen by over 200 people at Muchea tracking station near Perth, Australia. Additionally, Cooper maintained that he heard radio voice transmissions in an “unintelligible foreign language.” According to Don Wilson of *Our Mysterious Spaceship Moon* once again, the tapes of these signals were replayed by NASA and analyzed, but no known human language could ever be identified as the language on the transmissions. [593](#)

Even earlier, in 1956, the University of Ohio and other Moon-watching institutions reported that there was strange “codelike radio chatter” coming from the Moon. And in October of 1958, American, British, and Russian astronomers all reported observing something speeding toward the Moon at 25,000 miles an hour, emitting radio signals that, once again, no one could interpret. [594](#)

Once mankind *did* reach the Moon with the Apollo landings, the radio chatter — this time man’s own radio chatter - became even more suggestive. Consider the following transcript from Apollo 17, between its Ground Control (GC) on the lunar surface, and the Command Module Pilot (CMP) orbiting above.

CMP: What are you learning?

GP: Hot spots on the Moon, Jack.

CMP: Where are your big anomalies? Can you summarize quickly?

GC: Jack, we’ll get that for you on the next pass.

CMP: Hey, I can see a bright spot down there on the landing site where they might have blown off some of that halo stuff.

GC: Roger. Interesting. Very go to KILO KILO.

CMP: Hey, it’s gray now and the number one extends...

GC: Roger. We got it. And we copy that it’s all the way down there. Go to KILO KILO on that.

CMP: Mode is going to HM. Recorder is off. Lose a little communication there, huh? Okay there’s Bravo Bravo, select OMNI. Hey, you know, you’ll never believe it. I’m right over the edge of Orientale. I just looked down and saw the lights flash again.

GC: Roger. Understand.

CMP: Right at the end of the rille.

GC: Any chance of...?

CMP: That’s on the EAST of Orientale.

GC: You don't suppose it could be Vostok?⁵⁹⁵

CMP: I'll be damned. I've got to mark that spot on the map!⁵⁹⁶

Many in the UFOlogy community have pointed to this transcript as an indication that the Apollo 17 astronauts on the lunar surface saw a UFO, and maintain that the reference to seeing the old Russian Vostok probe was simply a last minute attempt to cover-up something that had already gone out on the airwaves in the clear.

But this is not what interests us here. What interests us is the clear reference by the astronauts to switch to what are apparently secure frequencies for their communications. This clearly would imply that they saw *something* that did not belong there, although it need not be a UFO. Whatever they saw, it does not make much sense that they would have gone to secure frequencies merely to continue a conversation about the Russian Vostok probe.

Exactly what they might have seen may be indicated by the transcripts of a conversation held between mission Ground Control (designated CAPCOM here) and astronauts Duke and Young on the Moon's surface:

DUKE: These devices are unbelievable. I'm not taking a GNOMON up there.

YOUNG: O.K., but man, that's going to be a steep bridge (sic)⁵⁹⁷ to climb.

DUKE: You got YOWEE! Man John, I tell you this is some sight up here. Tony, the blocks in Buster are covered, the bottom is covered with blocks, five meters across. Besides, the blocks seem to be in a preferred orientation, northeast to southwest. They go all the way up the wall on those two sides and on the other side you can barely see the outcropping at about 5%. 90% of the bottom is covered with blocks that are 50cm and larger.

Blocks!?!? Wall!?!? As if this is not enough, the conversation becomes even stranger, if not even somewhat surreal:

YOUNG: Mark. It's open.

DUKE: I can't believe it!

YOUNG: And I put that beauty in dry!

CAPCOM: Dover. Dover. We'll start EVA-2⁵⁹⁸ immediately.

DUKE: You'd better send a couple more guys up here. They'll have to try (garbled)...

CAPCOM: Sounds familiar.⁵⁹⁹

As if a "wall" and "blocks" were not enough, during Apollo 17 there was this short exchange between astronaut Schmitt and Mission Control:

SCHMITT: I see tracks running right up the wall of the crater.

MISSION CONTROL: Your photo-path runs directly between Pierce and Pease. Pierce Brav

go Bravo, Whiskey, Whiskey, Romeo.⁶⁰⁰

Wilson's commentary on these codes — Bravo Bravo, Kilo Kilo, and so on — is highly illuminating:

Mission control from time to time gave orders to the astronauts in some unusual terms, seemingly whenever an unusual sighting was taking place, directing them to Go to *Whiskey Whiskey* or *Barbara Barbara* or *Bravo Bravo* or *Kilo Kilo*. Interestingly, there is an ICBM base in Montana by the name of Kilo Kilo. Could NASA have used this base's radio equipment to filter out through this prearranged private channel anything NASA did not want the public to know? Shockingly, WHISKEY WHISKEY, BARBARA BARBARA, and BRAVO BRAVO are all bases in the West.⁶⁰¹

In my previous book *The SS Brotherhood of the Bell* I speculated on the possibility that there are in fact two space programs, an overt one, and a covert one wrapped up inside the public one.⁶⁰² If Wilson's statements here are correct, then it is one more indicator that the two space programs hypothesis is true, and it is a solemn reminder that mankind's presence on the Moon in the form of the Apollo missions may have had another agenda altogether, one well-hidden from the public. We will return to this theme of two space programs and a hidden agenda in a subsequent chapter.

4. Apollo 18 and 19

Perhaps the strangest anomaly of them all is the fact that, having spent so much time, treasure, and thought on reaching the Moon, the last two Apollo missions were suddenly and by any account mysteriously cancelled. Altogether, there were supposed to have been ten lunar flights, and the Apollo 18 and 19 rockets were “already paid for and the astronauts trained and raring to go.”⁶⁰³ Why then were these already-paid for missions scrubbed? The standard explanation has always been that the final four Apollo missions were cancelled for budgetary reasons. But this cannot be the explanation for canceling Apollo 18 and 19 for these, as has been noted, were already paid for. Some other reason must lie at the core of the mystery, but whatever it is, the American government and NASA are not talking. Perhaps, as some UFOlogists assert, we were “warned” not to return by someone who did not like our presence there. Or perhaps, too, we found whatever it was we were looking for.

5. *Leaping on the Moon: an Esoteric Symbolism*

Prior to the Apollo missions, it was an item of popular discussion to imagine the fantastic athletic feats that man could accomplish on the moon. Why, in 1/6th the gravity, a 180 pound man would weigh only 30 pounds. He would be able to leap much taller, run faster and farther, hit golf balls off the tee for a mile. This line of discussion was hammered home in children's *Weekly Readers* in schools, in television and film documentaries, in science fiction movies and novels, on late night talk show monologues and in almost every way conceivable. By the time of the Apollo missions, we were well-prepared to see some truly stupendous things.

But as William Brian II notes, we saw no such fantastic feats as we were glued to our television sets watching Apollo astronauts on mission after mission leaping around on the lunar surface.

Even with the astronaut gear...(Apollo 16 astronaut John Young) should have been able to jump over six feet off the ground if the Moon had one-sixth of the Earth's gravity. In actuality, his efforts lifted him at most 18" off the ground.... Observations...indicated that Young made several attempts to jump as high as he could but with no success in achieving a height of more than 18 inches.⁶⁰⁴

This fact corroborates the implications of Von Braun's statement concerning the neutral point of gravity between the Earth and the Moon, indicating yet again that the gravity of the Moon is much more than the public has been told.

And this in turn has led some revisionists to maintain that the entirety of the Apollo missions were hoaxed and done on a television mock-up set. But in fact, the small heights achieved by the leaping astronauts on all those Apollo landings in my opinion is a strong indicator that we went, and that, in this instance at least, NASA concealed nothing. Had NASA wished to hoax the missions on television stage or film set, it is hardly likely that it would have overlooked the obvious implications of leaps from astronauts that were far too short for a Moon with 1/6th the gravity of the Earth. So why the leaping at all? Why show everyone on Earth in the plainest possible fashion that the Moon is a much more massive object than our pre-Apollo science had led us to believe?

I believe in part that the answer to this lies in the fact that, if the Moon is more massive, then the likelihood of us getting off the Moon by means of the small rockets on the Lunar Excursion Module is very small. Rockets may have been adequate to the task of getting us there, but if, as our and the Soviets' earlier probe failures had already indicated, the Moon's gravity was already known to be more massive, then the leaping is a subtle but nevertheless definite signal that some other technology may have been in play in getting us off the Moon.⁶⁰⁵

But there may be *another* message altogether in the leaping exercises of the astronauts on the Moon, a message heavy with esoteric significance: leaping is associated with Mars, the "Great Leaping One" of so much esoteric literature. Indeed, the imperial Roman Salii priests who celebrated Rome's founding relationship with Mars did so by blowing trumpets and *leaping*.⁶⁰⁶ So perhaps the leaping of the astronauts is designed to convey both a scientific significance, and a *ritual* one. In this

respect, it has often been pointed out that many of the Apollo astronauts were Masons, and actually took Masonic regalia with them on their Moon missions to perform Masonic rites on the lunar surface, rites that were never broadcast to the public. And as Face-on-Mars exponent Richard C Hoagland has often pointed out, many of the space missions of NASA are oddly scheduled so as to fulfill certain astrological and celestial alignments.

It is not only the behavior of the Moon that is odd, it is also the behavior of our astronauts on it.

C. LTPs: Lunar Transient Phenomena and the Pre-Apollo Top Secret Telescope Program

Anomalous behavior has been observed about the Moon ever since man first trained telescopes on it and began keeping accurate records of observations. One of the strangest facts about the Moon are the surface features that are there at one time, and not at another, or which disappear slowly over time, or conversely, emerge over time. One of the most famous instances is the case of the disappearing crater named Linne. First observed by the German astronomer Johann Schroeter in 1843, Linne was estimated to be some six miles in diameter and approximately 1200 feet deep. During the course of several years' observations and careful lunar map-making, Schroeter eventually saw Linne disappear almost completely.⁶⁰⁷

Other astronomers have periodically reported seeing lights in the crater Plato, which then disappear, only to reappear again some time later. Other such changing phenomena, called Lunar Transient Phenomena or LTPs for short, are inexplicable changes in the color of the Moon's surface, dark spots that appear and disappear, and so on.

Then came 1953 and famed astronomer and selenologist Dr. H. P. Wilkins's, of "domes" that began to appear on the surface of the Moon. This was not the only problem. Wilkins also noted

That their number had been increasing rapidly. Similar reports were made by many expert observers. Wilkins could not explain their sudden appearance. Neither could other astronomers, for the newly discovered domes were near the limits of telescopic resolution, and the blurred features prevented positive conclusions. However, something was definitely responsible for the appearance of more than 200 strange domes.⁶⁰⁸

Indeed, as author David Hatcher Childress points out in his book *Extraterrestrial Archeology*, one of Apollo 15's precise mission objectives was for the astronauts to "describe the domes in the mare material and their probable origin."⁶⁰⁹

An Example of a Lunar Dome, Visible just above the Arrow in the Crater toward the top center of the picture.

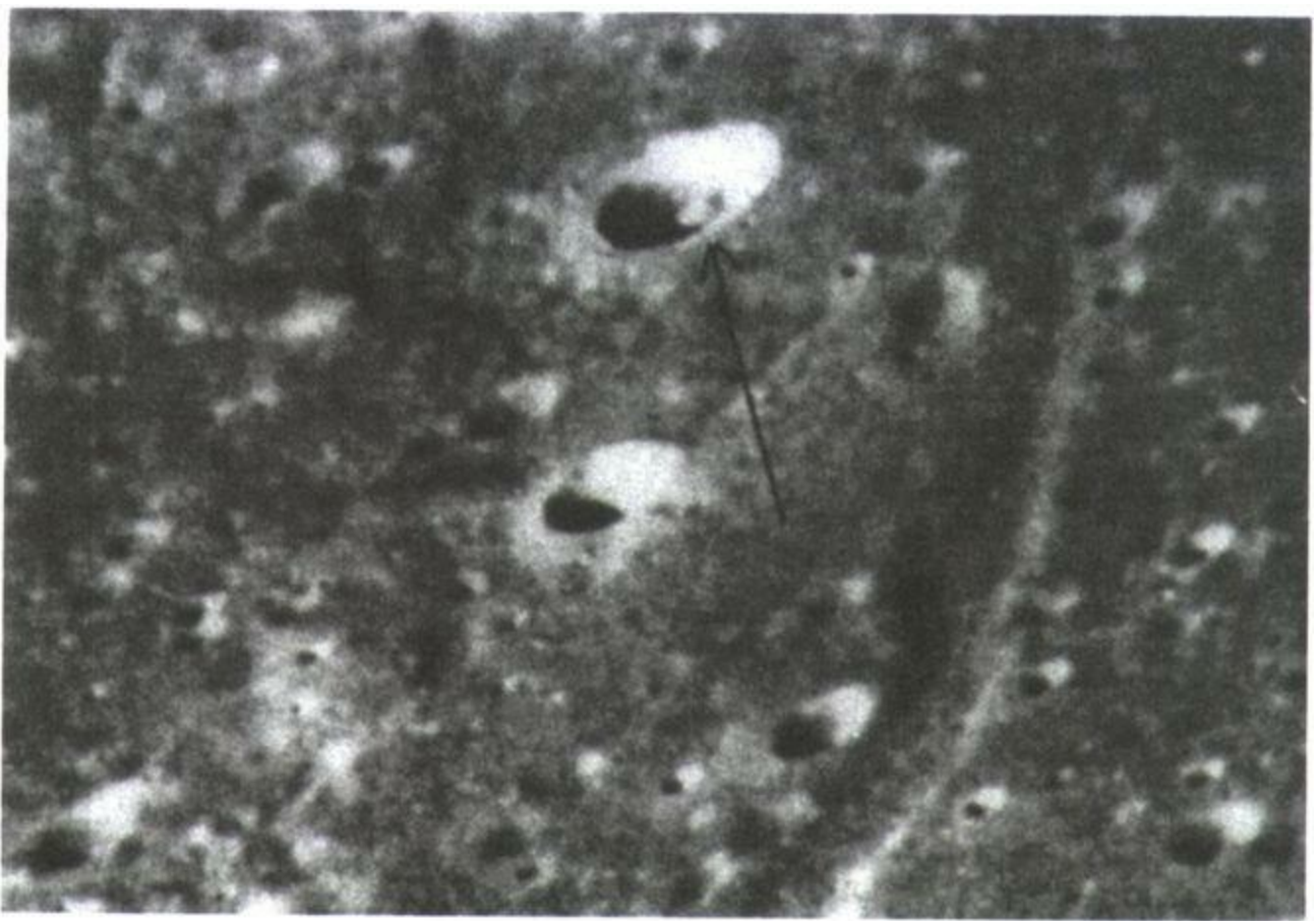

The observation of these domes and other transient phenomena by such respected astronomers and Wilkins apparently set off some sort of alarm in the intelligence corridors of Washington DC, for the Pentagon shortly thereafter began various programs to have the larger telescopes, such as at Mount Palomar, photograph the surface of the Moon in detail. These studies were classified Top Secret.⁶¹⁰ Lunar anomalies had become subject to national security guidelines.⁶¹¹ The year 1953 is significant, of course, for being the year following the infamous Washington DC, US Capitol UFO Flap of 1952 in which UFOs were seen on radar by American military personnel, seen visually over the US capital city, and chased by scrambled American Air Force fighter jets. This activity came at the end of a major period of UFO activity dating from just before the end of World War Two, with the famous “Foo Fighter” incidents over Nazi Germany in late 1944, to the period immediately surrounding the Kenneth Arnold and Roswell episodes of 1947.

Thus, when Lunar Transient Phenomena suggestive of an artificial origin, like “domes,” were observed, catalogued, and reported by someone of Wilkin’s prestige, and confirmed by other reputable astronomers from all over the world, the American military, nerves already on edge with endless UFO activity, was bound to sit up and take notice. Since 1953, as author Daniel Ross observes,

The National Security Agency had been behind the official censorship of information concerning UFOs, and now it was equally necessary for them to clamp down security regarding any proof of alien operations on the Moon. By 1954, the guidelines and restrictions were set, regarding any photographic studies or announcements by the big observatories concerning the Moon... Planetary studies of the Moon, Mars, and Venus, *that had the capability of disproving the*

uninhabitable theories, were now a matter of national security.⁶¹²

In other words, any data or information that indicated that Earth's closest neighbors might be inhabited had to be suppressed. But there is more to this agenda than just this, for it also meant that any data that suggested planetary environments on Earth's nearest neighbors even remotely conducive to habitability had also to be suppressed. And one must assume that the subsequent recommendations of the Brookings Report to withhold any evidence of past habitation on those planets also fell under that 1953 national security rubric.

Against this backdrop the strange coded language of some of the Apollo transmissions previously cited makes sense, for it is indicative of the same types of security protocols in place on the Apollo missions as were present in the telescopic studies and mappings of the 1950s. And that in turn would mean that they did indeed see "something" up there.

Following the same line of reasoning, it would perhaps also fall within the brief of these intelligence agencies to suppress any evidence of an interplanetary war that once occurred on these planets, for such evidence would also imply the existence of a technology. And perhaps this, ultimately, is the reason for the hidden military presence throughout the space program.

D. Shards, Octagons, Craters, and Towers versus “Incessant Meteoric Bombardment”

The surface of the Moon boasts a number of features suggestive of an artificial origin for themselves, and possibly for the Moon as a whole.

One of the strangest of these is the so-called “Shard” located south west of the *Sinus Medii* region of the Moon. The photo is from the Lunar Orbiter frame III-84M. The shadow of the object is clearly visible extending from the bottom of the structure to the lower right hand corner of the picture. The strange “star-like” light on the top of the structure is a camera registration mark and not actually a part of the structure.

The Sinus Medii “Shard” on the Moon

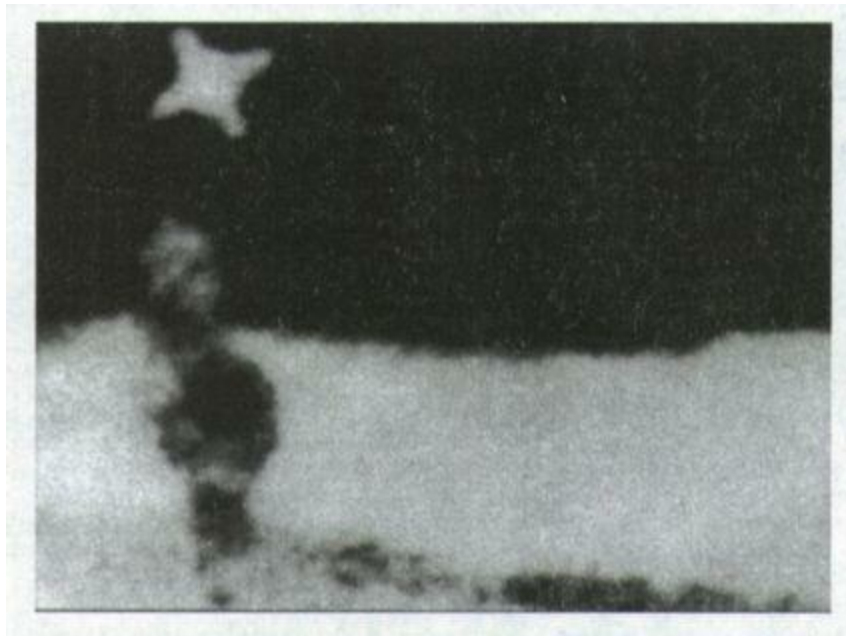

However, why call this strange object a “structure” at all? For one thing, it stretches some *one and a half miles* above the surface of the Moon. It is, in other words, enormous. But the fact that it is there raises certain questions. According to the standard model, the Moon is supposedly subjected to an unceasing rain of meteors, a “bombardment” that would batter down sharp edges and jagged mountains into smooth, rounded hills over the billions of years the Moon has existed. Yet, there it stands, with its strangely regular “twisted” or “spiral” geometry. The object not only exists, in spite of this unceasing meteoric rain, but it has preserved some apparently basic, structural geometry.

Yet another odd feature not explainable by the standard “meteoric bombardment” model are the presence on the surface of the Moon of craters and other oddly *rectilinear* formations, formations almost impossible to explain on the basis of natural geological processes, much less those of meteoric bombardment. For example, how would one explain the origin of the oddly rectilinear polygons in the following photograph?

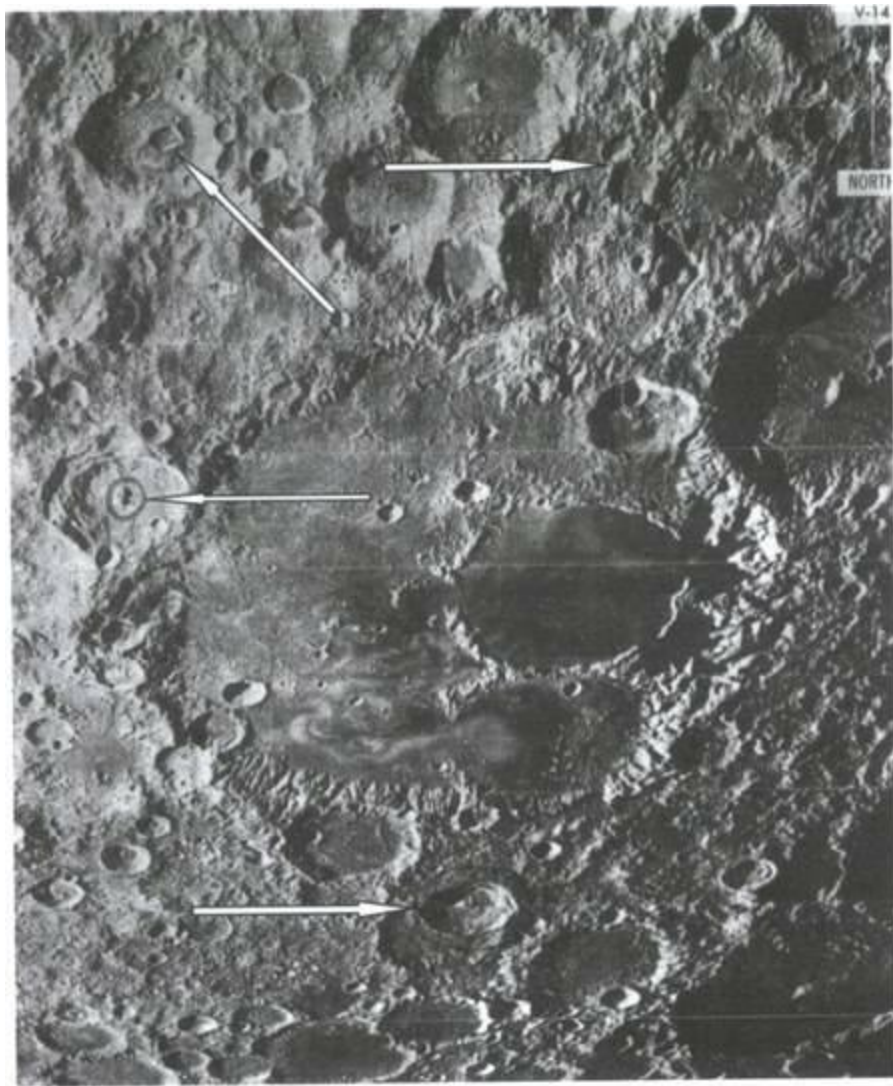

Note in particular the two very tiny pyramidal like objects in the left center of the picture. But most importantly, how would one explain the *octagonal* “crater” toward the bottom center? The meteoric bombardment is obvious from the picture. By the same token however, the rectilinear polygon shapes of some of these “craters” suggests the presence of an underlying structure and order.

Similar rectilinear structure is found in the following photo.

“Pie Slice” on the Moon

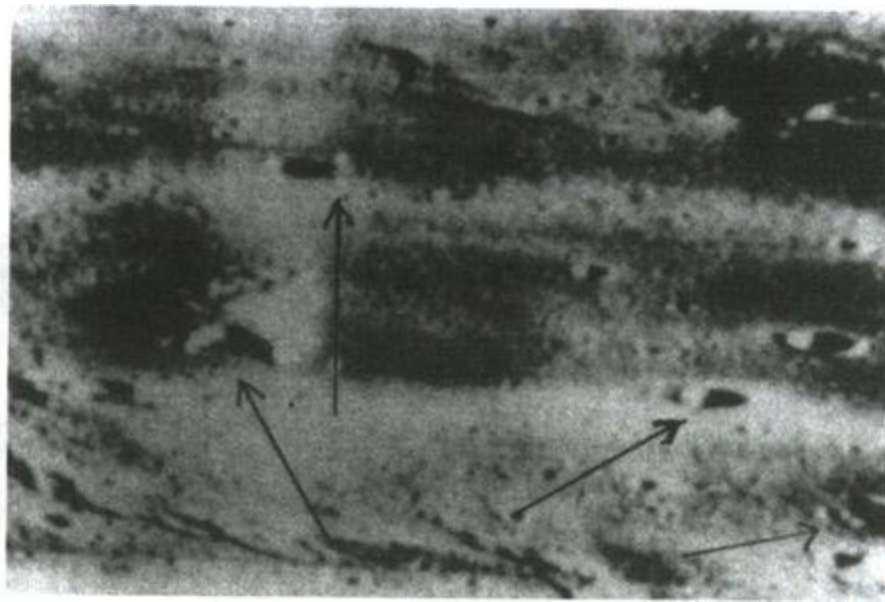

Note the pie “slice” cut to the left center of the picture, the “tower” like object immediately above it, and the two “double craters” to the right side of the picture. Again, meteoric bombardment over billions of years should have obliterated such features long ago. And no known geological mechanism would seem to account for such *neat and precise* regularity. The presence of such features once again seems to suggest an artificial origin.

1. Various Explanations for Shallow Craters

But even the vast majority of craters on the Moon which obviously are the result of the impact on its surface of space debris have a problem. Depending on the size and velocity of the meteor, the impact crater it leaves behind will vary in the depth of the crater. Thus, one would expect that the largest craters would have, by comparison, a relatively greater depth. Thus, the most familiar feature of the Moon, its many craters, some of them quite large, are ironically the most anomalous features of them all, octagons, pyramids, domes, shards and pie slices notwithstanding.

Despite their fantastic size, even the *largest* gaping holes are surprisingly *shallow*. Craters fifty, even one hundred miles in diameter are no more than a mere two to three miles deep... Even *conservative* estimates by scientists indicate that meteors 10 miles or more in diameter should have penetrated the Moon surface to a depth of 4 or 5 times that diameter; yet the deepest Moon crater we know about (the Gagarin Crater) is 186 miles across but less than 4 miles deep. The conclusion that some scientists drew is that there is something extremely tough and strong under the shallow lunar surface, beneath the thin layers of rock and dirt covering this mysterious sphere, that prevented deep holes.⁶¹³

In one case of a 148 mile wide crater, the depth is a mere 3 miles, about half of which is accounted for merely by the surrounding wall of rock thrown up around it. Weirder still is the fact that the floor of the crater is *convex, following the curvature of the Moon's surface*, rather than concave.⁶¹⁴

The mechanism most familiar to current science that can cause such shallow craters are ...thermonuclear explosions.

2. Double Cratering

Another odd feature of lunar craters was noticed by Richard C. Hoagland, after pouring over Moon photographs. This was the occurrence of “double craters,” craters in close proximity to each other, having the same size, and more or less the same directional orientation. Meteoric bombardment over billions of years might explain some of these, but not their fairly frequent occurrence on the Moon. Briefly put, the presence of such phenomena is suggestive of deliberate targeting, not random bombardment by meteors.

E. It Rings, Too!

A “superhard” layer of material beneath the surface of the Moon impervious to deep penetration by meteors; dense, localized areas of strong localized gravity causing orbiting satellites to “dip” and accelerate; enormously tall “shards” projecting out from the lunar surface in defiance of the meteoric bombardment; “pie slices” and other anomalously rectilinear formations on the surface; gravitational anomalies and shallow craters, suggesting the Moon is “hollow,” or at the minimum has an interior core of much less dense material than that towards its surface, a model itself at variance with standard models of the interiors of solid planets: all this suggests that the Moon, if not an artificial body in its own right, at least has some elements on and beneath its surface that are artificial in nature.

Confirmation of the “hollow Moon” idea came in a dramatic and unexpected fashion when the Lunar Module ascent stage of Apollo 12 was jettisoned from the Command Module after depositing the two astronauts on board for their return journey to Earth. The ascent stage was sent crashing back into the Moon where special seismographic equipment left on its surface recorded the shock waves and radioed them back to earth. The results “staggered NASA scientists. The artificially created Moonquake lasted 55 minutes!”⁶¹⁵ But this was not all. Scientists were baffled by the *type* of signals that were recorded. The waves started small, then gained in size to a peak, lasted “for unbelievably long periods of time.” This is completely different behavior from seismic waves generated on the Earth.⁶¹⁶ Subsequent experiments with components from the failed Apollo 13 mission, and later from Apollo 14, generated Moonquakes that lasted for about 3 hours and 20 minutes in each case, with the waves in each case traveling to a depth of 22-25 miles.⁶¹⁷

There was a further puzzle to the Moonquakes. Werner Von Braun revealed to *Popular Science* magazine in January of 1972 that the velocity of the waves gradually increased to a depth beneath the lunar surface of about 15 miles, whereupon there was a sudden increase, an increase only possible if the material became suddenly much denser. Around 40 miles beneath the surface the velocity of the waves was about 6 miles per second.⁶¹⁸ The outer maria of the Moon were composed of a mixture of metals, some of them very rare: iron, titanium, beryllium, molybdenum, and yttrium. It is perhaps significant that the velocity of sound through such material is approximately the same: about six miles per second. This suggests that deep beneath the lunar surface there is a thick layer of what can only be described as a “specially alloyed” compound of these rare metals.

This would explain why the Moon, to the shock of the scientists performing these experiments, rang like a bell.

Rounding out this picture of high lunar strangeness are the curious features noted about some of the moon rocks brought back by Apollo, and also by Soviet unmanned probes. Apollo 16 brought back samples of Moon rocks that contained rusted iron, an impossibility without the presence of free oxygen and hydrogen.⁶¹⁹ But the August 26, 1976 edition of the *Detroit Free Press* carried a short article from the Associated Press wire service about a startling Russian announcement. The Russians it seemed, had discovered their own particles of lunar iron returned to the Soviet Union in one of their probes. The iron could not, did not, and would not *rust*. As the newspaper noted, such “rustless” iron cannot be manufactured on Earth” and yet, to be rustless, some sort of manufacturing process has

to be involved.⁶²⁰ The only other place such rustless iron is known is the iron column in New Delhi, India, thought to be incomparably old and also, like the lunar rustless iron, this pole does not rust, though it has stood outside enduring monsoon after monsoon.

Finally, lunar soil and rock samples that were brought back to Earth by Apollo 12 and 14 contained traces of Uranium 236 and Neptunium 237, isotopes that were “never previously found in nature.”⁶²¹ Of course such isotopes may be synthesized, but that is the point: prior to the Apollo missions they had to be synthesized.

F. Apollo 12 and 13 and Other Moon Miscellanies

This excursion into lunar anomalies would not be complete without mention of the Apollo 12 and 13 missions, and their very near disastrous outcomes. Apollo 12 was only the second of man's flights to land on the Moon, lifting off from Earth in November of 1969. However, less than a minute after lift-off the craft was struck by lightning when it was barely a mile and a half above Earth. All its electrical systems were shut down. The astronauts — Charles Conrad, Dick Gordon, and Allan Bean — worked calmly and restored all the craft's electrical power and systems.⁶²² The origin of the lightning bolt was a mystery, since the nearest weather reports of lightning were some twenty miles distant.⁶²³

Then, while on the way to the Moon, observatories from around the world reported seeing flashing lights both leading and trailing the spaceship. The day after lift off, November 15, 1969, the three astronauts radioed Mission Control that they also had spotted the “bogeys,” i.e., the UFOs.⁶²⁴

The Apollo 12 lightning-UFO episode has led some UFOlogists and others to speculate that someone was trying to halt manned missions to the Moon and, having failed to do so, traveled along with it to keep a close eye on things. While possible, another explanation would be that the Soviet Union might have been using some of its own Tesla weaponry to stop the missions.

An even more chilling rumor was related by NASA insider and engineer Maurice Chatelain regarding the ill-fated Apollo 13 mission. Chatelain maintained

That there was a lot of talk and speculation within the space agency about the unsuccessful mission. It seems that Apollo 13 was carrying a secret payload - a nuclear device that was to be detonated on the Moon's surface. The nuclear test would be measured by the seismographic packages left on the surface at the two previous Apollo sites, in order to determine the infrastructure properties of the Moon. A predominant opinion circulating at the space agency was that a UFO trailing Apollo 13 deliberately caused the mysterious explosion of an oxygen tank in the service module, in order to prevent the planned nuclear detonation.⁶²⁵

While the idea of a “secret nuclear payload” seems highly unlikely, it is interesting that elements inside of NASA would even be speculating along such lines, much less along the lines of a deliberate sabotage of the mission by an “extraterrestrial power.”

What emerges from all this is that there is a substantial case for the idea that, at the minimum, the Moon is covered in anomalous formations highly suggestive of an artificial origin. And at the maximum, all the strange features of the Moon's gravitational pull, its almost impossible-to-account-for celestial mechanics in its orbit around the Earth, its oddly shallow craters, the apparent presence miles beneath its surface of a hard metallic “inner crust”, and its ability to “ring like a bell,” may point to the whole planet being a gigantic artificial structure.

Something else has emerged from all this as well, and that is the persistent presence within the space program - from the first days of organized observation of the lunar surface by the Pentagon and the various intelligence agencies in 1953, to the heavy presence within the astronaut corps itself - of the military. It has been suggested in this chapter that one possible reason for this heavy military

presence in the initial days of space exploration, was to suppress any data that indicated former or current habitation of our nearby celestial neighbors. A reason for this was also suggested, and that is that the “hidden” space programs of the United States and the Soviet Union may have been not only to suppress evidences of an ancient war, but also to possibly recover the technology that made that war possible.

This last possibility - that of covering up evidence of an ancient war while simultaneously seeking to recover some of the lost technology of that war - will loom as an even larger possibility in the next chapter.

MARS, AND THE FEAR OF MARS

*“It was (John Brandenburg’s) suggestion that, if the craters on this part of Mars were ‘artificial,’ there would be a way to tell — because nuclear explosions (as opposed to meteor craters) would be shallower... On the other hand, he said(undercutting, in the next breath, my brief hope that here was a **definitive** test!), the craters produced in targets in the lab, as part of the new Space Defense Initiative tests, were deep — not unlike meteor craters themselves — a direct result of the **way** they were produced: by the exotic particle beams ‘burying’ their energy deep within the targets. ”*

Richard C. Hoagland⁶²⁶

Along with the Moon, Mars is without doubt the planet that has the most hold on the human imagination. Its persistent association with war and destruction within astrological lore goes back as far as recorded human memory extends. And ever since the Viking Mars probe took its famous picture of the Sphinx-like Face on the surface of that planet’s Cydonia region, it has become the focus of a protracted debate between “Face believers” and “Face debunkers.” Previous chapters have shown that, in so far as ancient myth is concerned, Mars and its ruler(s) was a definite and decisive player in the ancient Cosmic War. Accordingly, one may look for anomalous objects on the surface of Mars, for corroboration of the idea that there was once a civilization there, and one may look also for evidence that at least some of Mars may have undergone deliberate destruction. However, since the whole Cydonia-Face controversy has engendered so much debate, nothing will be said about it here except toward the end of this chapter. Here our concentration will be on other anomalous features on Mars’ and its satellite Phobos’ surfaces that are suggestive of an artificial origin. The reader should bear in mind that what will be covered in this chapter is but a very small sampling of a very large catalogue of anomalous formations on that planet.

A. Mars Surface Anomalies

1. The "Airport"

The following picture and its computer enhancement were taken by Mariner 9. Ever since, the strange formation, which exhibits structural elements, including rectilinearity and other regular geometric designs, has been dubbed the "Airport" for its resemblance to a modern airport terminal.

Mariner 9, # 4209, of the "Airport" on Mars. Location 1.9° S 186.4°W

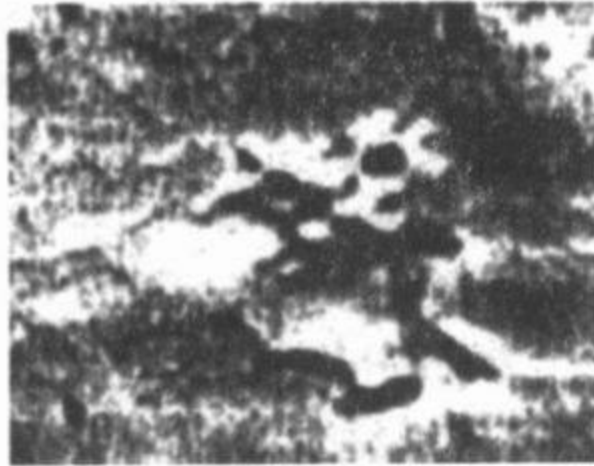

Computer Enhancement of The Mariner 9 Airport



It is conceivable that some sort of geological process could account for such a formation. But as will be seen, if this is the case then Mars is home to a variety of geological processes of a very exotic nature, since there are so many disparate types of anomalies to account for.

2. "Hexagons"

For example, consider the following hexagonal structure on the surface of Mars. While hexagons do form naturally in crystals, it is difficult to imagine such a large structure arising from natural crystal-forming processes. The following photos were taken by Mars Global Surveyor.

Mars Global Surveyor Hexagons

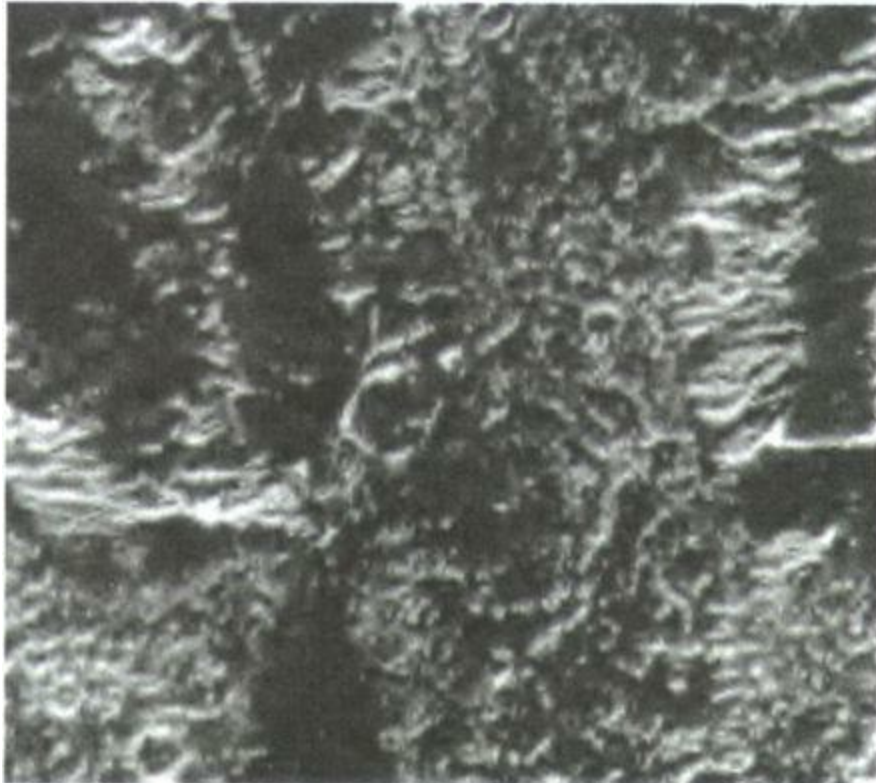

In this picture there are actually two hexagons visible, the large one toward the center, and a smaller one towards the lower left hand corner. Some unknown geological process might account for the rise of such structures, but if that were the case, how would one account for the apparent isolation of the unknown geological process in this region, and for the fact that only two such hexagons appear to have been formed?

3. *Pyramidal and Other Rectilinear Formations*

While giant hexagons and “airports” might be accounted for by some unknown and exotic geological process, four-sided pyramids possessing symmetry along perpendicular axes is a whole other matter.

A Martian Four-Sided Pyramid

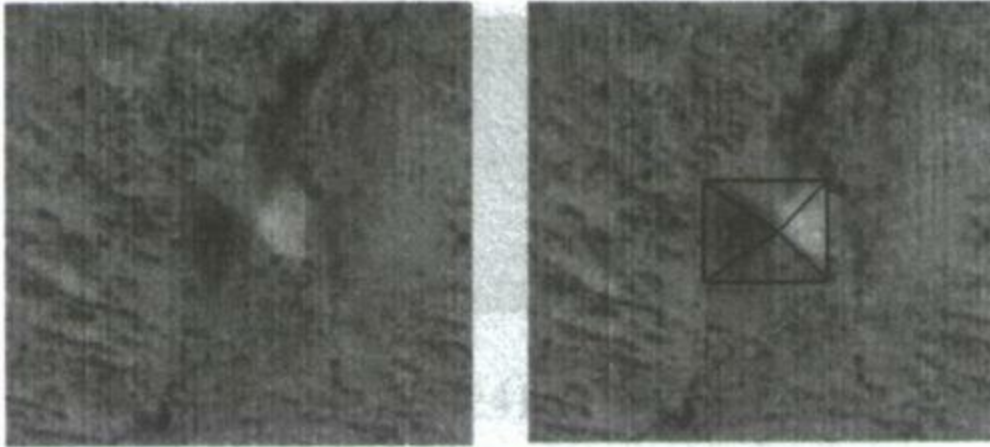

The Cydonia region, thanks to the efforts of Richard C Hoagland, Errol Torrun, Vincent DePietro Mark Carlotto and so many others, is well known to be dotted with a number of pyramidal formations, including the large and well-known five-sided D & M Pyramid. But the presence of such structures in other areas of the Martian surface strongly suggests that one is in the presence of a common cultural matrix. The Sphinx-like Face, the Cydonia Pyramids and other formations, and now another pyramid *not* in Cydonia, decreases considerably the likelihood that the Cydonia formations are accidents of nature. Geological processes might explain large hexagons and large “airports”, but they will not adequately explain such formations, which are not known to occur in nature. This fact, along with the presence of such structures on the Earth, and the odd presence of rectilinear and other regular surface features on the Moon suggestive of artificiality, imply that we might be in the presence of a common culture.

Another odd feature found on Mars is the presence of *depressions* in its surface that, superficially, resemble craters, but which, on closer examination, reveal themselves to have a degraded rectangular structure underlying them. Again, the question inevitably arises of how would natural processes such as meteor impacts account for such features?

Double Rectangular “Craters” on Mars



An even more stunning example of a rectangular “crater” is the following.



Again, what natural process would account for this?

Another picture, released from Malin Space Systems, appears to be nothing but a typical region of Mars, with some non-descript geological features.

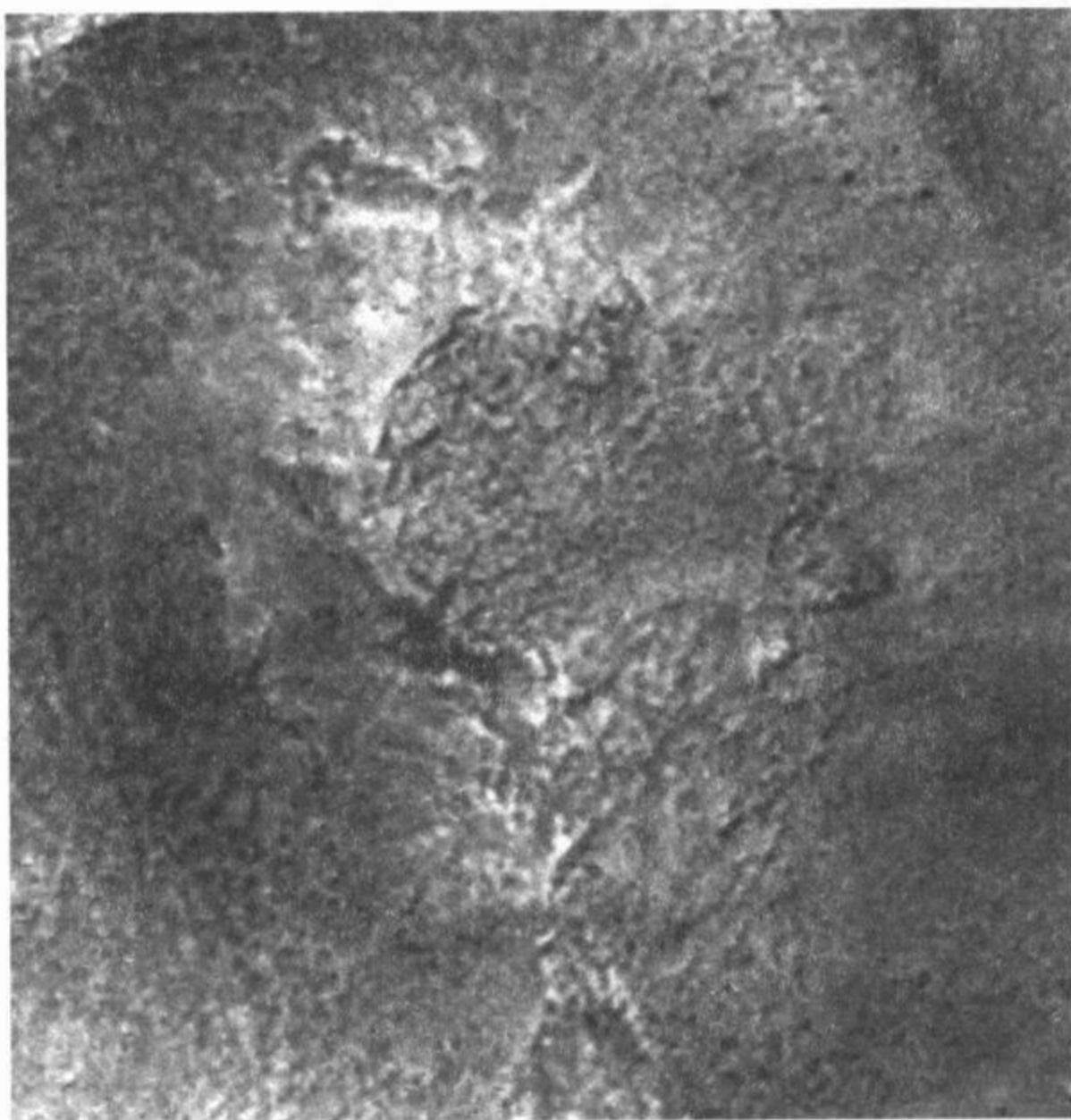

But closer inspection will reveal a wealth of details about this “non-descript” formation that are quite anomalous. Note first that the bulge is almost perfectly circular. And note the zigzag rectilinear feature to the left on the top of the bulge. On the right side of the bulge note again the straight lines that form a “design” almost reminiscent of a seventeenth and eighteenth century Vauban-style fortress.

The “Bulge” with Zigzag lines and “Vauban” Style “Fortress

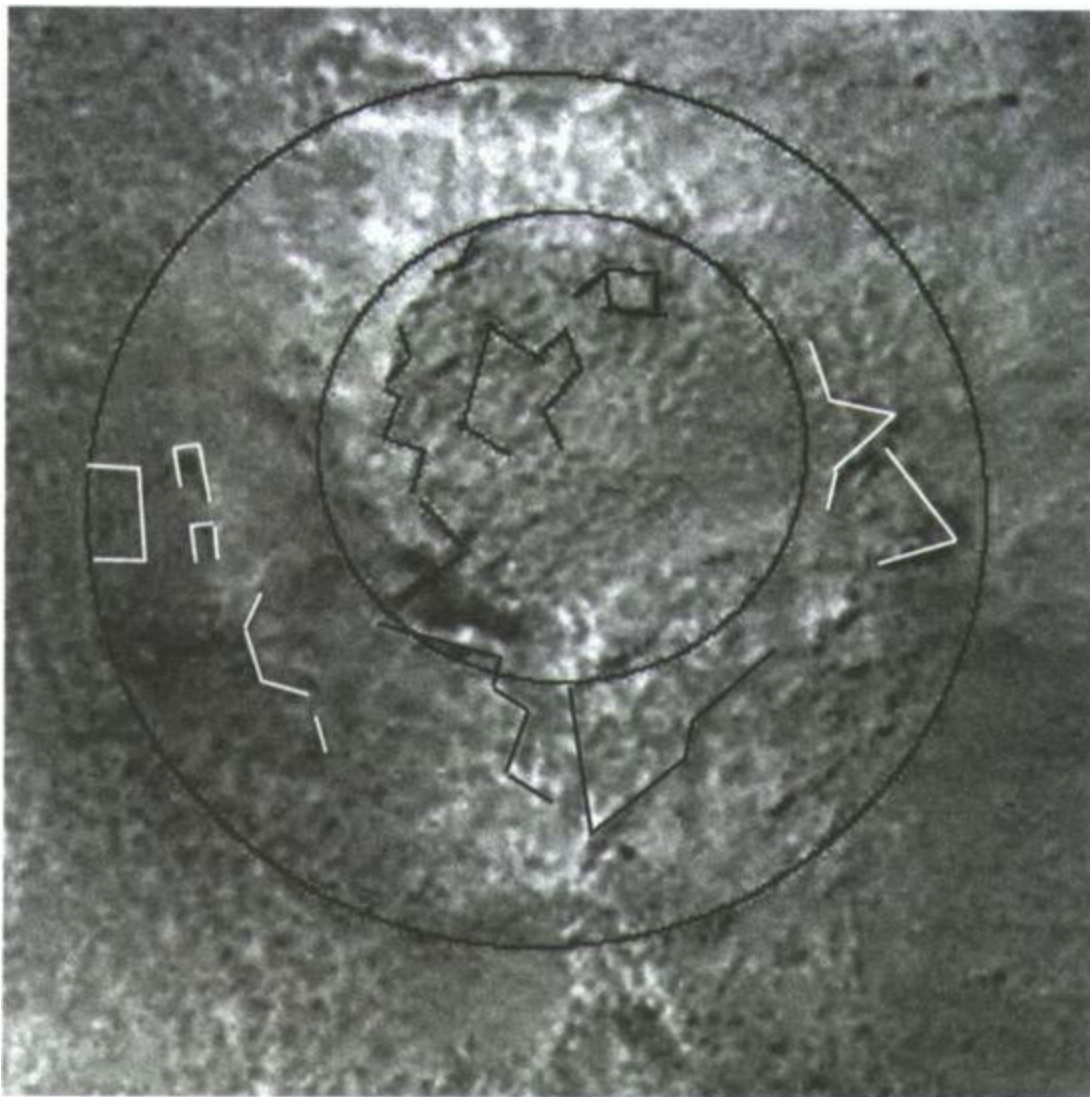

This extremely interesting feature with all its anomalous characteristics might be accounted for by geological processes, to be sure, but if so, then it would appear that a number of discrete and very different processes would be at work, and in a most unusual combination. In short, natural causes might account for *some* of these features, but for all of them to be present in one location, with such straight-lined regularity, would seem to stretch plausibility. The only other explanation is that these features are the creations of intelligence, and that *one is looking at degradations of structure that have occurred over time.*

4. "The Monoliths"

One very difficult feature to explain by natural causes is a grouping of what appears to be monoliths. This photo was actually released by NASA under Dr. Malin — in charge of the Mars Global Surveyor — a feat in and off itself.

Mars Monoliths Grouping

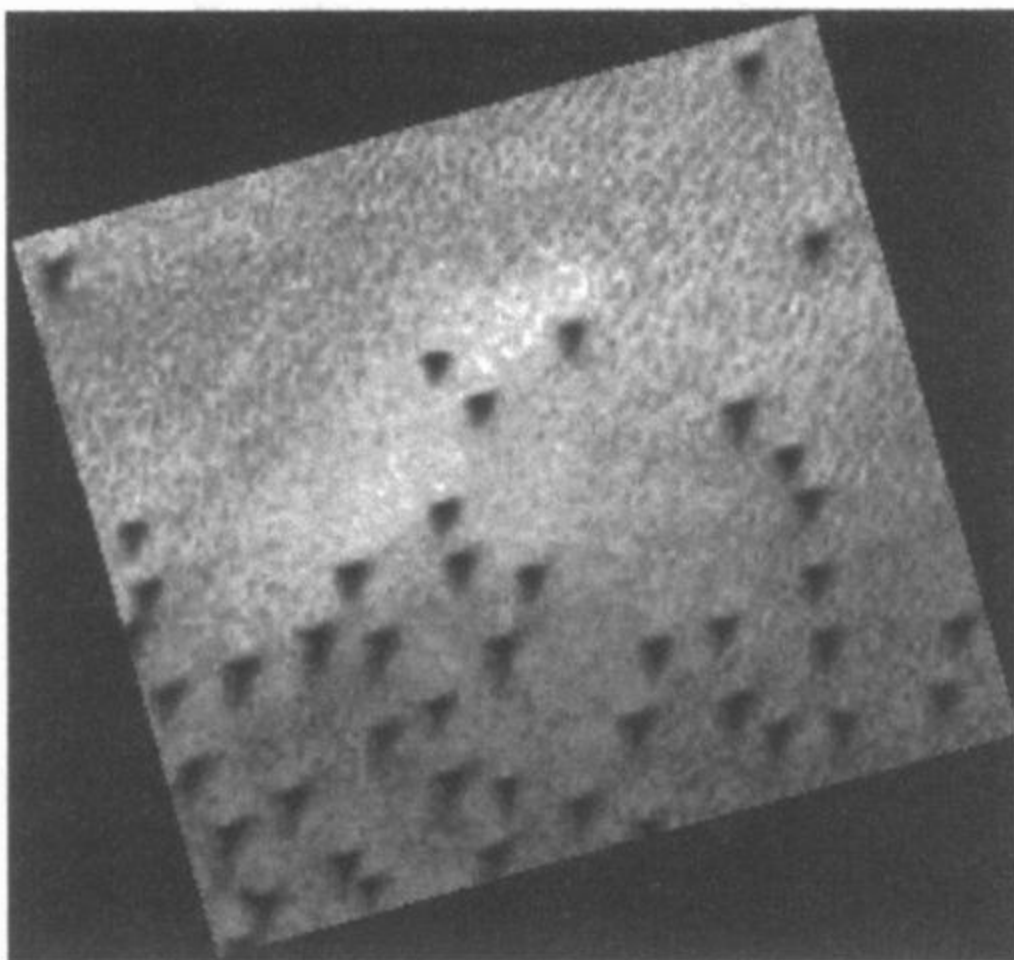

What are these odd objects? And what geological process might account for them? On any view, it would be difficult to account for this feature as being merely and exclusively the product of natural causes, and if not, one is left with artificial intelligent construction.

5. *More Double Cratering*

A feature found on the Moon is also found on Mars: “double cratering.” Richard Hoagland, again was the one who noticed this odd characteristic, and began to wonder about a mechanism that could explain it. To see why, it is necessary to place what he says in the context of his wider musings on craters.

Craters themselves — whether double or not — are a significant geological technique for the dating of surface features on planets.

- 1) Given that every other solid planetary body in the solar system has major portions of its surface “saturated” with large (above 20 km) craters — Mars has roughly one entire hemisphere (the southern) covered with such craters.
- 2) Given that the central assumption for the creation of these “shoulder-to-shoulder” craters is that there was a period of intense bombardment very early in the history of the entire solar system — Mars’ heavily cratered terrain most probably dates from this “heavy bombardment period” as well.
- 3) Given that the presence of these ancient crated terrains on the Moon, Mercury, and the satellites of the outer planets...bespeaks preservation in the airless vacuum of these objects’ surfaces — the preservation of similar terrain on Mars argues forcefully for negligible erosion, most likely from the lack of dense atmosphere for most of the lifetime of the planet.
- 4) Given that the other hemisphere of Mars (the northern) matches similar terrains on the Moon and Mercury, in terms of far less cratering — this “two-faced” distribution of craters argues ...that there was a dramatic drop-off in the rate of cratering for Mars, consistent with a solar system-wide termination of “heavy bombardment” 4 billion years ago.⁶²⁷

While Hoagland is here following the standard line that such cratering is due to the early stages of the solar system and its presumed intense bombardment of planets by meteors, and therefore that he is following the standard model’s dating of such surface features with an age more or less concurrent with that of the planet’s formation some four billion years ago, Hoagland is quite alive to other possibilities of explanation, and therefore, for the formation of these features in much more recent times.⁶²⁸

The presence within the southern, heavily-cratered hemisphere of Mars of many apparent water-run off channels in the same terrain, however, indicated a problem. For the standard theory, it indicated that Mars either had abundant water very early in its planetary history, or that it was suddenly inundated with abundant water. Either way, this appeared to pose problems for the age of Mars. For one thing, it meant that water and atmosphere were stripped from Mars at a very early period, making the idea of intelligent life dwelling on that planet quite problematic. This, plus the anomalous “Face-Sphinx” and pyramidal structures at Cydonia on Mars, which were of an apparently later date, was the problem. How to reconcile the two conflicting data streams? Hoagland was thrust back upon the method of “dating by cratering,” and began to look at the Viking Cydonia images from this point of

view:

The area of the single Viking frame encompassing the objects - 35A72 — was slightly less than a thousand miles in area. - a thousand times *smaller* than the areas used for “crater counting” in the literature. Nonetheless, I decided to apply this tried and true technique to this single Viking frame, for it would give me some rough estimate of the numbers of craters in this region of the planet — and thus a rough idea of the underlying landscape’s age...

And moments later I was presented with a paradox: there were “too many” craters.

....

(The) actual numbers of craters in the picture, exceeding a kilometer in size, was *three to five times* the numbers in the published curves. This could be explained by “clumping” (the numbers were a statistic fluke...), or they could be real...

In which case, this region of Cydonia was among the oldest on the planet — over 4 *billion* years in age! [629](#)

It is worth pausing for a moment to consider this possibility in the light of what has been written previously here about the *primordial* nature of the revolt and cosmic war in the pantheon. If — and it must be emphasized that this is a gigantic “if” — Cydonia and its artifacts were that old, then it would constitute *prima facie* corroborative evidence of this primordial cosmic war.

However, such an extreme date for all these Martian anomalies need not actually have been the case. Van Flandern’s Exploded Planet Hypothesis in any of its versions would also explain why there is such heavy cratering on Mars and *much more aptly explain why it is limited to largely the southern hemisphere of that planet*. It would similarly explain why Mars shows every sign of having been suddenly and violently inundated with water. It would explain the run-off channels and their presence in heavily crated areas quite easily. But this would place the cratering dates at a much later 65,000,000 or 3,200,000 years ago. This is more acceptable, to be sure, in terms of the possibility of the presence of life on Mars.

Hoagland began to turn his attention to the phenomenon of double-cratering, i.e., twin craters of almost the exact same size and internal features, laid out in neat linear patterns. But there was another problem he noticed about many of the craters on Mars, whether double or not: *many were too shallow to have been caused by impacts*. This, plus the evidence of strange damage to the admittedly eroded “Face” and even stranger apparent damage to the massive five-sided D&M Pyramid on Mars formed “one of the most disturbing observations” that Hoagland made, “that the objects at Cydonia exhibited considerably more than ‘natural degradation’ — for any reasonable age.”[630](#) And it all went back to Hoagland’s highly anomalous crater counts for the Cydonia Viking frame.

This led him to pose the following significant question. This, and the response of the scientist whom he consulted, is cited extensively below, for it is of paramount importance as corroborative evidence of the Cosmic War Hypothesis:

Was it possible (I’d dared to ask myself, after the numbers consistently came out too high), that the evidence of significant erosion on the Face and pyramids - and the abnormally high number of 1-kilometer creators in the area were a result of some powerful *artificial* agent...?

In other words, had life on Mars — the Roman “God of War” — been exterminated in an all-out *nuclear holocaust*?!

The thought was too fantastic...yet, it could explain a lot of things ... the craters... and the other evidence I’d seen; in examining the City under the magnifying glass, I’d viewed direct evidence of *melting* and *flow* on the Main Pyramid within the City. In addition, there was the apparent massive destruction of much of the southeast sides of both that structure, and the equally puzzling “Fort” — *and* of forces which had, somehow, apparently completely vaporized (or blown off) the “roof” which must have originally covered up “the honeycomb!”

Then, there was the strategically placed “impact crater” in the south-eastern flank of the D&M pyramid, and the equally suspicious “domed uplift” distorting its geometry. Was this the work of some kind of “rocket-borne explosive” — which had penetrated the interior of the pyramid, and then detonated, leaving an exit “blow-hole” type crater, and severe internal structural deformation?

Very cautiously, during our second phone call, I explored with (plasma physicist John Brandenburg) the kinds of craters a nuclear exchange would leave behind, and the “statistical anomalies” of so many craters on the objects of most interest — like the Face and the D&M pyramid.

It was his suggestion that, if craters on this part of Mars were “artificial,” there would be a way to tell — because nuclear explosions (as opposed to meteor craters) would be shallower... On the other hand, he said (undercutting in the next breath, my brief hope that here was a *definitive* test!), the craters produced in targets in the lab, as part of the new Space Defense Initiative tests, were deep — not unlike meteor craters themselves — a direct result of the *way* they were produced: by exotic particle beams “burying” their energy deep within the targets.

Now shades of ray guns and Orson Welles’ green Martians!

More significant was the fact that (John Brandenburg) had access to people at the lab who did have information regarding the kinds of exotic *isotopes* a nuclear exchange would likely leave behind within the atmosphere... [631](#)

Remember the Xenon¹²⁹ found on Mars, a nuclear by-product not normally encountered naturally?

What Hoagland has clearly implied is that the Cydonia region shows every sign of having been deliberately targeted and destroyed in a war, a war that notably was fought not only with nuclear bombs, but exotic energy weaponry, weaponry recalling the plasma discharges of Anthony Peratt, and the ancient petroglyphs. Cydonia, in other words, constitutes not only strong *prima facie* evidence of a civilization on Mars, but also of a war, a cosmic war, that destroyed it.

6. *Plasma Discharge, Valles Marineris, and Strange Sumerian Myth*

But why call this war “cosmic,” inferring that it was of an interplanetary nature, and not simply a war fought just on Mars itself, by elements of the civilization that was there? The answer, as seen in chapter two, lies in a peculiar “interdisciplinary” piece of evidence, that of the colossal gashing wound on the surface of Mars called the Valles Marineris:

The Valles Marineris



Reference has already been made of this unusual feature of Mars in chapter two, and to the fact that it fulfills geologically the ancient mythological archetype of the “wounded warrior,” for in mythology and astrological lore, Mars — Nergal, Aries, Herakles in his Babylonian and Greek nomenclature — was certainly a warrior. A *wounded* warrior.

After all the foregoing chapters, it should not now surprise us that there is possibly very curious corroboration of this gashing wound from the ancient Sumerian myth, the *Lugal-E*, which we have

referred to previously in this work.

To recapitulate what was previously said about the *Lugal-E*, it recounts the revolt of Azag against Ninurta, and Ninurta's subsequent "inventory of the stones." However, we now draw attention to some other features. In the myth, Azag is referred to as a "fearless warrior,"⁶³² a title with suggestive connections to Mars as we have seen. But most curiously are the *Lugal-E*'s identification of Azag, not with a person, but with a *thing*, an object of incredible power, as the following passages indicate:

The Azag rose to attack In the front line of the battle.

The sky it pulled down as a weapon For its hip, took it in hand,

Into the earth it struck the head snakelike

...It screamed wrathfully

Like a formidable serpent It hissed from among its people

It wiped up the waters in the highland Swept away the tamarisks,

It gashed the earth's body.

Made painful wounds

...

And till today black cinders are in the fields. ⁶³³

If one take the statement about a gash made "in the earth's body" as a reference not to this specific planet, but rather simply to the ground beneath one's feet, to a planetary frame of reference in general, then the depiction of Azag's war against Ninurta in this passage fits remarkably well with the features on Mars recounted by Hoagland and others.

For example, the statement that the Azag "pulled down the sky" as a weapon, plus the subsequent sentence that it intended it as a weapon for its "hip," that it could "take in hand" implies a sword. Azag's weapon appears as a version of Zeus' divine thunderbolt and Ninurta's divine lightning discussed in chapter two. It sounds very much like the plasma discharges of Anthony Peratt. Thus, the gashing wound that it made, whose "black cinders are in the fields" up "till today" is a reference to a gaping wound of planetary scale, a wound made by "lightning," whose scorching effects are still visible. The *Valles Marineris* fits the bill perfectly for a "wound in a warrior," Mars, that is caused by lightning, or plasma discharge, which is still visible. This type of discharge, moreover, could easily be taken as "pulling down the sky" and striking like a sword "into the earth" in a twisting, lightning bolt fashion, like a snake.

The planetary context, in other words, of at least some parts of the *Lugal-E* would appear to fit better with events on Mars, than on Earth.

B. The “Fear” of Mars: the Moonlet Phobos and its Monolith

In this context of the Azag as a “thing”, and a context for some parts of the Lugal-E taking place on Mars, the peculiar features of Mars’ little moonlet Phobos should be considered. Phobos,⁶³⁴ a name which in the Greek means “fear,” is an unusual object in its own right.

Mars’ Moonlet, Phobos



Note carefully the large crater, barely visible in the above picture, which more or less faces toward the right of the Moonlet, looking toward the surface of Mars. A close-up of this feature follows:

Close-up of the Large Crater Feature on Phobos

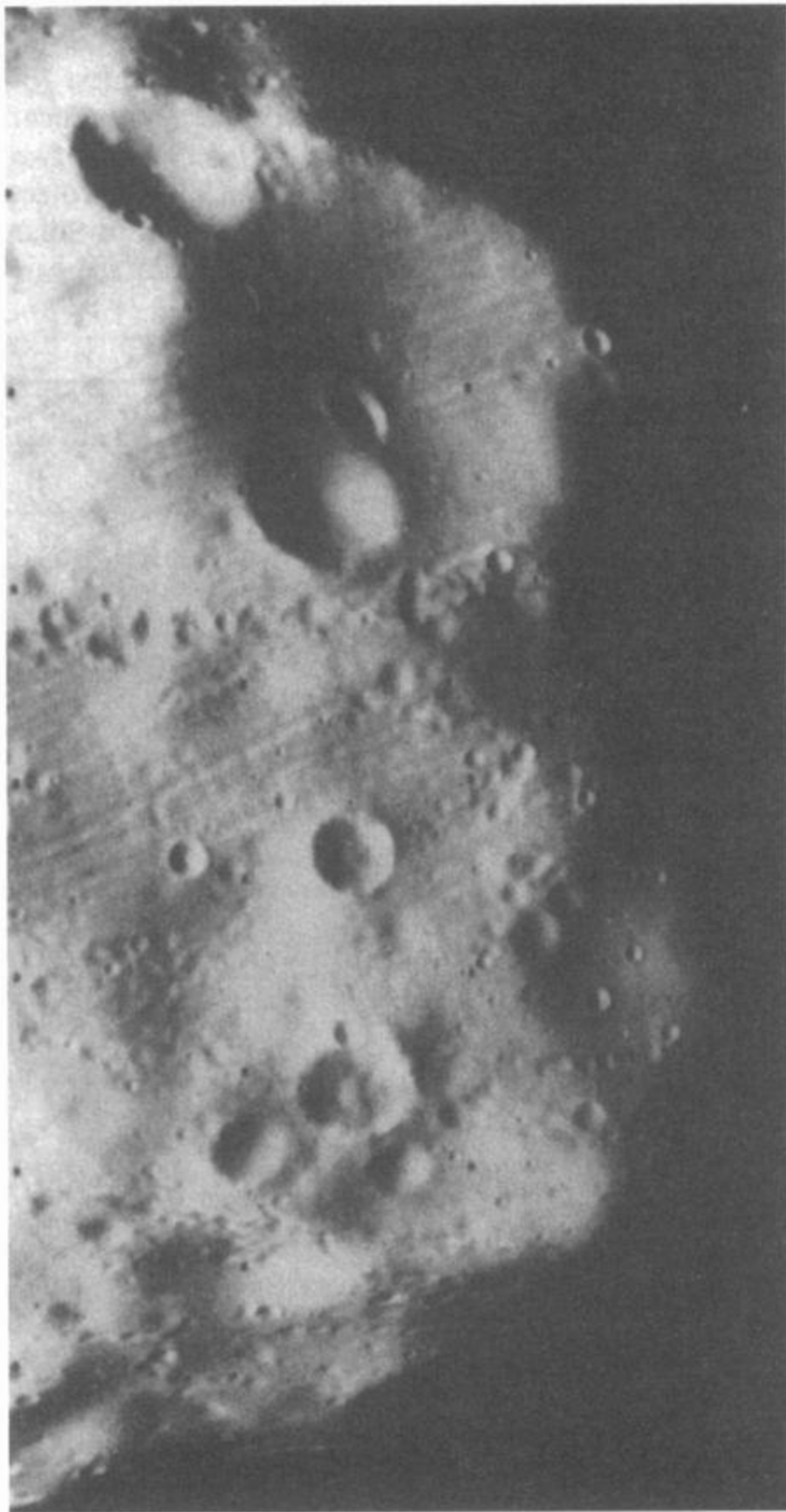

Careful scrutiny of this picture will reveal that the large crater is hexagonally shaped!

Phobos' Peculiar Hexagon Crater

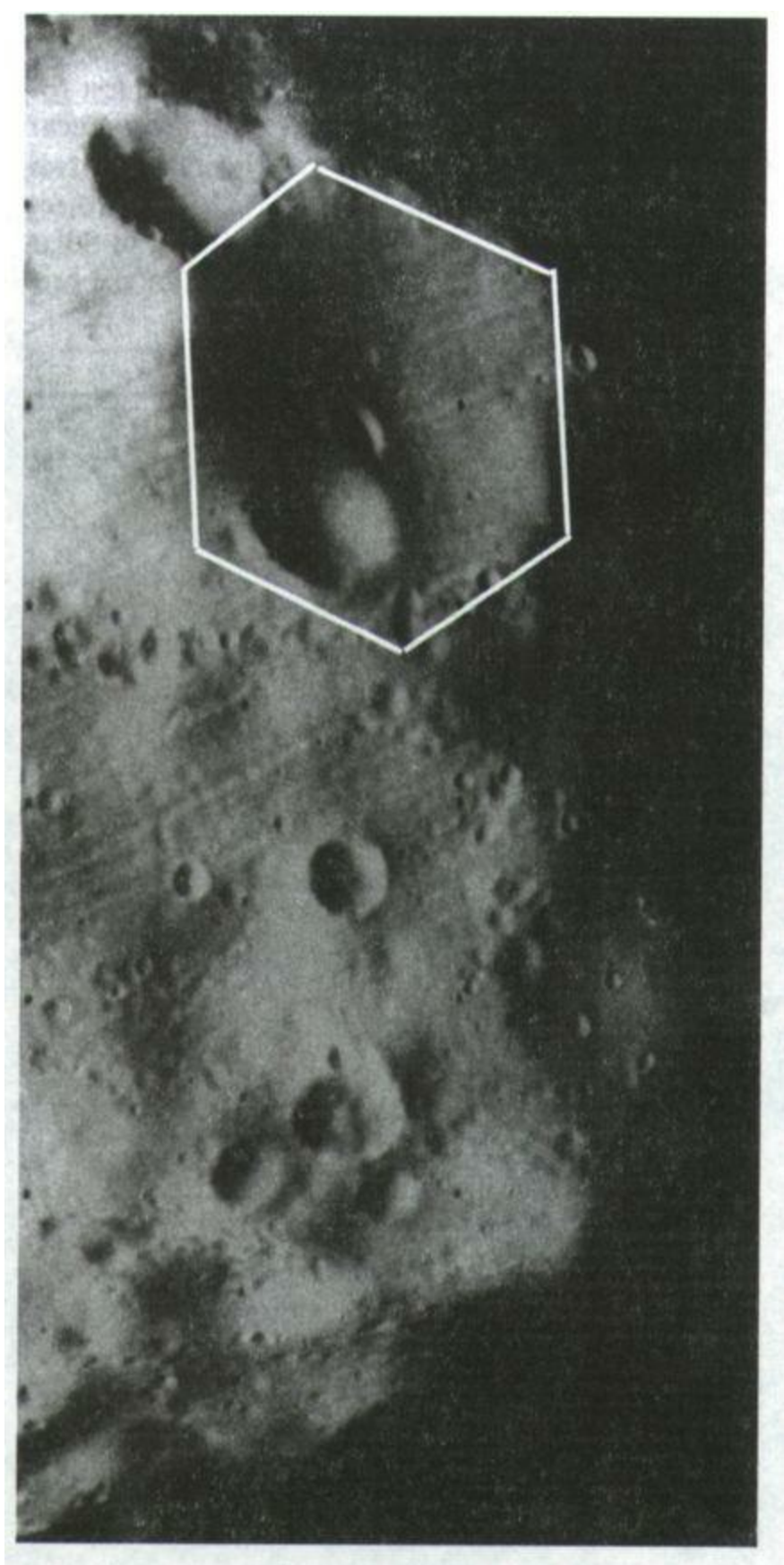

This feature, plus the strange grooves running on the surface of the little moon just beneath the hexagonal crater, suggest, once again, that there is more afoot on Mars and its satellites than just natural geological processes. As we shall see in the next chapter, the strangeness of this feature is magnified by the fact that there is almost an exact analogue of this feature on yet another moonlet, far far away from Phobos.

The strangeness of this little moonlet does not end there. The following picture of a small “tower”, its square shape and shadow clearly visible, is also from Phobos.

Small “Cylindrical Tower” on Phobos



Additionally, Phobos also has its own gravitational anomalies that strongly suggest that it, too, might be a “hollow” moonlet. Indeed, the Soviets were the first to suggest, as they did with Earth’s far larger Moon, that Mars’ little satellite might indeed be an artificial object in its entirety.

And well they might, for Russian attempts to explore the Red Planet and Phobos have met with some very disastrous results, the most extreme example of which was the apparent deliberate destruction of their Mars probe Phobos II on the 25th of March, 1989. Just before transmissions from the probe suddenly ended, it sent back the following picture of the shadow of an object on the surface of Mars itself, an object that was in the vicinity of the moonlet Phobos. The Russian probe also photographed a now famous picture of a long, thin, cylindrical object beneath the Martian moon shortly before all further communication was permanently lost.

Shadow of Cylindrical Object Cast on the Surface of Mars, Photographed by the Russian Phobos II Probe, 25 March, 1989

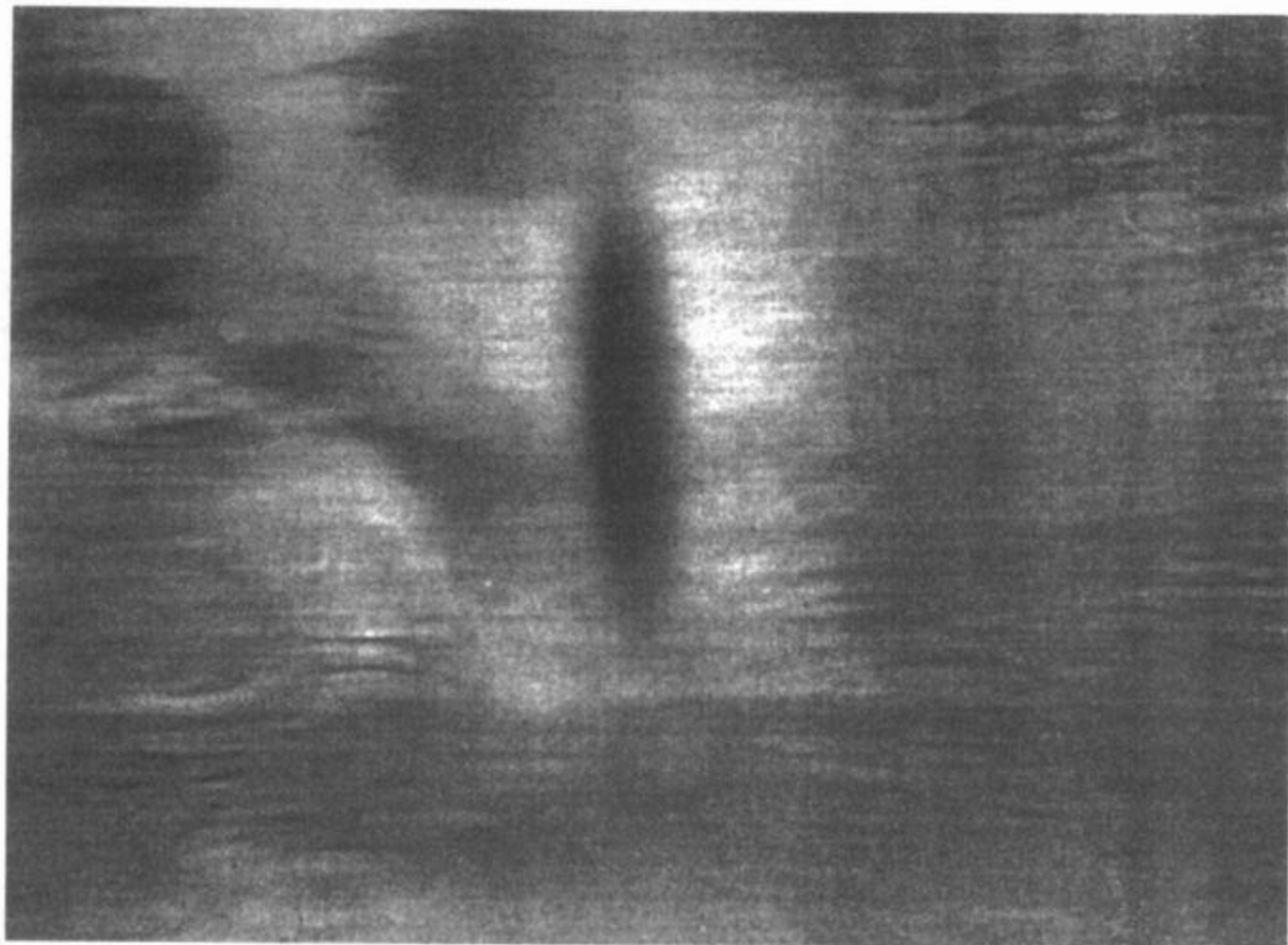

Photograph of Long Cylindrical Object Beneath the Martian Moon Phobos Taken Before Transmissions Ceased, 25 March 1989



Needless to say, the Soviet Union at first placed these photographs under the highest security

classification, then, for some reason, decided to share these two pictures with the United States. This fact led some Russian scientists to conclude that Phobos itself was an artificial moon, and that their probe has been deliberately attacked and neutralized by the cylindrical object that it photographed just prior to the probe's loss.

C. The Two Space Programs Hypothesis

1. The Occult Basis of Missions Timing

The presence of such anomalies on Mars, and the equally mysterious objects and structures on - and *around* - its little moonlet Phobos, highlight the hypothesis of Two Space Programs, one a public one for show, and the other a deeply covert and hidden one, in no uncertain terms.

In its most recent form, the Two Space Programs Hypothesis has been advanced by such luminaries as former astronaut, physicist, and PhD Brian O'Leary, and of course, Richard C. Hoagland. O'Leary maintains that the United States - and therefore presumably anyone else with a space program — has maintained a hidden military program under the auspices of the US Air Force in conjunction with various intelligence agencies of the American government. This program has run at least since the inception of NASA, if not before, and oftentimes its missions are wrapped within NASA missions and sometimes its missions are run entirely independently of NASA. O'Leary maintains that this program has its own launch facilities, vehicles, and its own corps of trained astronauts kept well away from the public eye.

In its Hoagland version, however, the Two Space Programs takes on an additional aspect. Hoagland has often pointed out in interviews on radio shows, and in various papers found on his website, that many space missions appear to be timed to take place when certain astrological conditions or alignments occur. He has marshaled over the years a vast body of evidence to suggest a strong prima facie case that this is so. Additionally, Hoagland has also pointed out that the very names of the space projects of the “golden years” of NASA — Projects Mercury, Gemini, and Apollo - are full of astrological and occult significance. Hoagland and others have pointed to the existence of a variety of Masonic and esoteric symbolism in mission logos, and the heavy presence of Masons within the astronaut corps plus the performance of Masonic rites on the Moon as indicating a hidden, covert or occulted aspect to the space program.

2. A Covert Missions Objective: The Quest for and Recovery of Paleophysics and Paleotechnology

This heavy Masonic presence, plus the astrological alignments of many space missions, does indeed suggest a covert and little known agenda behind the space program. Indeed, as author William Henry has observed, the quest for the recovery of ancient science and technology became

An essential feature of their secret society. In November 1752, when George Washington became a Mason in Fredericksburg, he heard the following words:

“The proper business of a Mason is astronomical, chemical, geological and moral science, and more particularly that of the ancients, with all the mysteries and fables founded upon it.

“Let us endeavor to turn the stream, to go from priest-craft to science, from mystery to knowledge, from allegory to real history.”⁶³⁵

Weighed in the balance along with the Masonic presence in the early astronaut corps and the likelihood of an additional and hidden military program, it would thus appear that there is another aspect to the Two Space Programs Hypothesis, and that is a *paleophysical* one. It would appear that one goal of the space effort is to “turn the stream” in precisely the Masonic sense alluded to above, to recover the ancient physics, and its associated technologies.

If so, then the implications are staggering, for it means that from the inception of the space age, someone had already determined on the basis of the then-existing evidence, that this evidence was sufficient to indicate *that such technology existed and by implication, that such wars were fought*. It stands to reason, then, that any evidence supporting such conclusions in the public sphere would be either suppressed or tampered with.

In short, the reason that NASA does not come clean with an admission of the artificial nature of Cydonia or of other Martian anomalies is not because they are indicators of a former civilization there. It is rather because the mythological context - the Cosmic War context - of those artifacts is also known, and that context implies the possible existence of a science and technology that may be recoverable.

a. Hoagland on the Paleophysics Message of Cydonia

Hoagland and some of his closest associates have persistently hinted at such possibilities - though admittedly not in such starkly clear terms — with their insistence that the whole Cydonia complex embodies a geometry that encodes a lost, “hyper-dimensional” physics. He does not mince words about the enormity of the physics he believes is embodied at Cydonia: it “involves nothing less, we now believe, than the fundamental *constructive energy* of the Universe...whose existence - and accessibility — was apparently *one* of the prime reasons for the very creation of the ‘ruins’ at

Cydonia.”⁶³⁶

In Hoagland’s view, the Cydonia complex is an encoded message of this physics, a message that he also finds echoed in “ancient Egyptian temples and other ‘sacred’ structures here on Earth.”⁶³⁷ But there might be another functional reason for the geometries that Hoagland and his associates found at Cydonia beyond that of merely memorializing a “hyper-dimensional” physics. Hoagland himself hints at this function by his own suggestion that the region was deliberately destroyed in a war. He himself points to the peculiar damage done to the D&M pyramid as the best example of this intentional destruction. So might it be that the geometries found at Cydonia are there, like the geometries in the Great Pyramid, for some other, less benign purpose? Might the compound be, as I have argued in my *Giza Death Star Trilogy*, a vast military compound, and might the D&M pyramid be the Martian version of the Sumerian Azag, able to “pull down the skies” on its enemies? Might it be a kind of Martian “Rostau”?

The answer to these questions is, I believe, a tentative yes.

But whatever the answer to them is, Hoagland has done one significant thing in his work, a significance few have appreciated. He has pointed out, for those who would care to weigh what he has said carefully, that there is a *common cultural matrix, inclusive of common architectural forms, that is shared between Earth, and Mars*. In short, he has given the Cosmic War of the Pantheon a planetary context from which to be viewed.⁶³⁸

b. The Possible Locations of the Tablets of Destinies Based on the Scenario: Giza, Iraq, and Mars

The possibility that there is a hidden “paleophysics” component to the Two Space Programs Hypothesis now raises another significant question and possibility. As has been seen throughout this work, the “interplanetary context” of the Cosmic War Hypothesis involves the local space of our solar system, including the planets Earth, Mars, and, as we have also seen, Saturn, Jupiter, and their satellites, and finally, the Sun itself.

As was seen in chapter two, a physics sufficient to the task of tremendously scarring planets by means of plasma discharges does exist, and this physics in turn couples quite easily to an even more powerful physics - scalar physics - in which the planets and the Sun act as massive natural resonators of stresses in the medium. And as we speculated in chapter eight, the Tablets of Destinies — the cause of that Cosmic War and one of the principal means by which it was fought - were ultimately components in the technology that tapped these tremendous resources. As noted in part two of this work, the components of these Tablets were inventoried, and some carted off and used elsewhere by the victors in a kind of “paleoancient Operation Paperclip,” some were deliberately hidden because of their potential destructive power, and because of the impossibility of destroying them, and some components were permanently destroyed. All of these features of the story have the profound ring of truth, for precisely such events transpired after the end of World War Two, with the Allied inventory of the Nazi war machine’s arsenal of exotic technologies. Some of it was carted off to be used elsewhere in other applications, some of it was permanently destroyed and lost, and some of it was

deliberately hidden because of its enormous potential for destruction. The parallels are amazing, and make the ancient myths ring of an underlying truth.

And the ancient myths, viewed against this interplanetary context provided by the review of anomalous data from our nearby planetary neighbors, also allows us to reconstruct the general locations for some of these missing components. As was seen previously, the myths suggest quite obviously that modern day Iraq, and Giza or other “ancient sacred environs” in Egypt, are locations where these components might be found some day, buried beneath untold yards of sand and dirt. But another location must also surely be Mars, and possibly even the Moon. If the Two Space Programs Hypothesis is true, then *perhaps* this too forms one of its hidden mission agendas.

c. The Remote Viewing of Lost Technology: Implications of Hurtak and the Face

And this raises a last possibility.

While the “Face” on Mars and all the attendant controversy surrounding it are well known, it is not so well known that it was viewed before the Viking probe first photographed the Cydonia region. Dr. James J. Hurtak, well-known antiquities scholar and esotericist, claimed to have remote-viewed precisely such an object before the Viking probe ever reached Mars.

While I remain personally skeptical of the spiritual influences and consequences of such techniques, I do not doubt their actuality or even their accuracy. Thus, while it is possible that Hurtak was merely releasing information that had been made available to him, information that in turn was collected by technological means well in advance of its actual public release date, I am skeptical of this explanation, and tend to take Hurtak’s claims here at face value, since they were published in a book before the Viking photos were ever taken, much less making the rounds in the general public or becoming topics of magazine articles and radio talk shows.

Hurtak’s viewing of the Mars Face thus raises another disturbing possibility, one known to be in use presently by the various countries’ militaries and also by large corporations researching exotic technologies, and that is that such technologies might be located via such processes. And it raises the possibility that such processes were being used to guide technological exploration of Mars long before probes were actually sent. If so, it casts another shadow on the Two Space Programs Hypothesis. It will only be a matter of time before someone, somewhere, attempts to use the same process to view and generally locate the missing components of the cause of that Cosmic War, the Tablets of Destinies.

And after that, it will only be a matter of time...

THE LORD OF THE RINGS OF SATURN

*“Without venturing a hypothesis, even an ‘outrageous one’ — attempting to knit together all the various assembled facts into some kind of a coherent **storyline** (the speculative part) - ‘science’ would simply be an exercise in making **lists**....”*

*Richard C. Hoagland*⁶³⁹

It is perhaps only fair that the epigraph for this chapter be taken from a series of papers - essays really - by Richard C. Hoagland, and posted on his website, for his thoughts on what he himself justifiably calls the “most baffling” and “the most important object” in the solar system,⁶⁴⁰ including the Cydonia Face and all the other anomalies on Mars and even on Earth’s Moon, will form the main focus of this penultimate chapter. Indeed, Mars’ tiny moonlet Phobos, and the Earth’s own gigantic Moon, are not the only satellites to exhibit anomalies that betoken a possible artificial origin. The “most baffling” and “most important object” in question is Saturn’s “moon” Iapetus, and the reasons for the qualification of Iapetus as a “moon” will become abundantly clear.

Hoagland’s remark comes from a series of papers entitled *A Moon With a View: Or, What Did Arthur Know, and When Did He Know It?*, a subtitle that reflects the curious fact that internationally-known and respected science fiction author Arthur C. Clarke first speculated on a catalogue of weird facts about one of Saturn’s many satellites, and by any reckoning, its strangest. Clarke did so in his well-known fictional work *2001: A Space Odyssey*, a work that predated the many photographs that we will examine in this chapter by approximately three decades. Hoagland’s work is entirely about Saturn’s “moon” Iapetus.

We have already encountered in this book the peculiar association of Mars with Saturn in ancient mythology. However, it is an association extending far beyond the astrological relationships usually conceived in this regard. The association is, in fact, related to the Cosmic War itself, and to the role of Saturn in it. This role is best exhibited by a brief consideration of Saturn in Greek mythology.

A. Saturn in Greek Mythology: The War With the Titans

Hoagland summarizes Saturn's role in Greek mythology in the following fashion:

Iapetus...is the seventeenth of Saturn's thirty three currently known moons, and the third largest. It was named after a Titan - the son of Uranus and the father of Prometheus and Atlas (the latter said to be the "fathers of Mankind"). Thus, in Greek myth, Iapetus was also an ancestor... a *progenitor*... of "Homo Sapiens Sapiens."

....

The current names of Saturn's major moons, taken from a group of "superbeings" in Greek myth called "Titans," were given them by Sir John Herschel, in 1847. Herschel's nomenclature for Iapetus and the other six (then) known moons, was based on the logical association of Saturn ("Cronus" (sic) in Greek) with the Titans; Herschel, continuing the ritual, named the largest Saturnian moon "Titan" itself - in honor of the entire pantheon.⁶⁴¹

But Kronos (to give Saturn's Greek name literal transliteration) was more than just the father of the Titans. In Greek mythology he was the "first god" prior to Zeus, and he was overthrown by a rebellion against him by the Titans, who were, let it be noted, a race of *giants*.

So in other words, the entire mythological conceptual matrix concerning Saturn - at least in Greek mythology - is precisely that of the ancient Cosmic War in the Pantheon, a war which, in its Greek version, is clearly associated with rebellion and a race of physiologically large humanoids called Titans. And Iapetus is precisely one of these Titans. The Titans, rebelling against Kronos, eventually overthrow him, and in turn are overthrown by Zeus, who then becomes the more familiar principle god in the Greek pantheon. One might therefore justifiably amend the subtitle to Hoagland's essay to include the more pertinent question of "What did the ancient Greeks know, and when did they know it?"

Hoagland does eventually mention the connection of Saturn and Iapetus with this ancient cosmic civil war in the pantheon, but ultimately favors a very different hypothesis, as we shall see. In my opinion, however, the mythological context of the War Against the Titans forms an essential backdrop from which to view the anomalies of Iapetus, and from which to weigh the various hypotheses Hoagland advances to explain them.

B. The Anomalous Orbital Mechanics of Iapetus

Like the Earth's Moon, Saturn's "moon" Iapetus has an orbit whose physical mechanics makes it next to impossible that the "moon" was "captured" by Saturn's gravitation as it wandered aimlessly through the solar system. And in the case of Iapetus, it is an impossibility acknowledged by all that it did not "fission" and separate from Saturn early in the history of the formation of the giant ringed planet. Ever since the astronomer Cassini first discovered the small satellite in 1671, its orbit around Saturn has been a mystery. Unlike all of Saturn's other known satellites, only Iapetus' orbit is inclined some fifteen degrees from Saturn's equator; the rest of Saturn's satellites all orbit at the equator. And like the Earth's moon, Saturn's Iapetus also orbits Saturn, and revolves on its own axis, in such a fashion that one of its hemispheres always faces Saturn, while the other does not.⁶⁴²

But these are but the least peculiar features of Iapetus' anomalous orbital mechanics! It is best to cite Hoagland's summary of the other strange features of its orbital mechanics in their entirety, to place his concluding remarks in the wide physics context that his stunning concluding observation deserves:

Once the (amazing) possibility is admitted that Iapetus could be an *artificial* "moon" — and may have been deliberately *inserted* into such an odd orbit - the "coincidental" nature of its unique, steep inclination (relative to the other similar-sized Saturnian moons - Dione, Rhea, etc.) goes away.

But, equally "coincidental" is the shape of Iapetus' inclined orbit...and its precise *distance* from Saturn.

Iapetus' orbit is extremely close to being circular —

Shades of Earth's Moon!

with an eccentricity of only 0.0283 departing from a perfect circle by slightly less than 3%. (By comparison, our Moon's orbital eccentricity ...is 0.0549 or ~6%...essentially *twice* as eccentric as Iapetus!)

For an almost *circular*, very high inclination orbit to have formed through "random chance" is really pushing coincidence - if the agent for achieving that low eccentricity *and* the high inclination is supposed to be the same "*random*" collisional event, back when Iapetus was forming.⁶⁴³

Recall that such orbital mechanics were strong arguments advanced by some scientists for the radical notion that Earth's Moon was an artificial satellite that had been "braked" and "parked" into terrestrial orbit. In other words, if one advances the argument for the Moon having been artificially *steered* into Earth orbit on the basis of its perfect circularity and the fact that its orbital mechanics also show only one hemisphere to the Earth, then much more so is it the case for Iapetus and Saturn!

And, there's more.

The sharp reader will have noticed, from the preceding references, that Iapetus orbits slightly less than 60 radii away from Saturn (59.09) radii, to be exact...). This discrepancy, 0.15% - in the artificial model that *precisely* 60 radii was originally intended - would represent how much Iapetus has drifted since it was “parked” (as a designed “station”) in Saturn orbit. That rate of drift, either due to Saturnian/sun tides, or other forces...could give another way to estimate - other than by counting craters - roughly “when” this entire scenario in fact occurred....[644](#)

Hoagland is here referring to the fact that Iapetus orbits Saturn some two million miles from the planet, which is almost exactly sixty times the radius of Saturn. And that number, sixty, should sound very familiar:

That “ideal” Iapetus distance from Saturn just “happens” to also be base 60 - another tetrahedral number — suddenly appearing *in the first Sumerian civilization on Earth some 6000 years ago...* [645](#)

In other words, Iapetus’ orbital mechanics are massively artificial, and even bear a connection to *Sumeria!*

As if this were not enough, Hoagland even runs the numbers a bit further, in order to drive home the point that Iapetus’ orbit simply is not explainable on any naturalist model.

If you take the inclination of Iapetus’ orbit (~ 15 degrees) and multiply by its distance in Saturn radii (60), the result is the *average* of the current (Cassini probe) triaxial measurements of Iapetus’ diameter - ~ 900 miles!

All these numbers - Iapetus’ size, distance from Saturn, and orbital inclination - are “independent variables.” Meaning - *none* of them are automatically *interrelated*, or mandated by *any* current theory of satellite formation. Yet, for some reason, they have all come together in Iapetus... this one bizarre “moon”...orbiting Saturn. This simply makes no sense, and the odds of it happening coincidentally - especially, resulting in the actual diameter of Iapetus expressed in *miles!* Are (really!) “astronomical” —

Unless this was *designed!*[646](#)

But statistically improbable orbital mechanics for a *natural* satellite are the *least* substantial arguments that may be advanced in favor of the artificiality of Iapetus. To see why, one must actually *look* at Iapetus itself, a vision that was only possible in very recent history, with the Cassini probe’s mission to the ringed planet, and its many *extremely* unusual photographs of the “moon”.

C. Anomalous Surface Features of lapetus

1. The “Yin-Yang” Moon

Our exploration of the unusual features of Iapetus - and we catalogue but a few mentioned by Hoagland in his excellent series - begins with the fact that this “moon” has two distinctly different regions, a “dark” region, and a “white” region, that is, a region of high albedo and reflectivity, regions which are *not* mere artifacts of photography, but actually present on the small “planetoid.” Even more strangely, these regions are roughly interpenetrating ellipses, a pattern that earned Iapetus the nickname the “Yin-Yang” Moon, after scientists saw the following photo taken by the Cassini probe:

Iapetus, the Yin-Yang Moon [647](#)

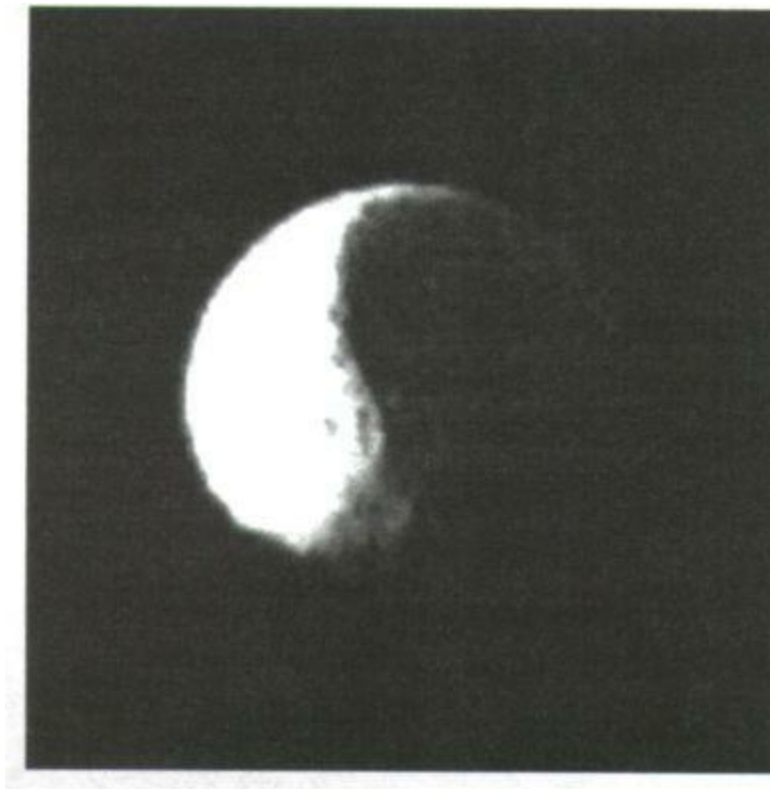

And there is another feature denoting artificiality, one that we have encountered before, on Earth’s Moon, and again to an even greater degree, on Mars and its little moonlet, Phobos: hexagonal cratering.

2. Hexagonal Craters, Again and Again

A careful examination of the following Cassini probe photograph will reveal numerous craters of Iapetus are in fact degraded hexagons.

Iapetus' Hexagonal Craters[648](#)

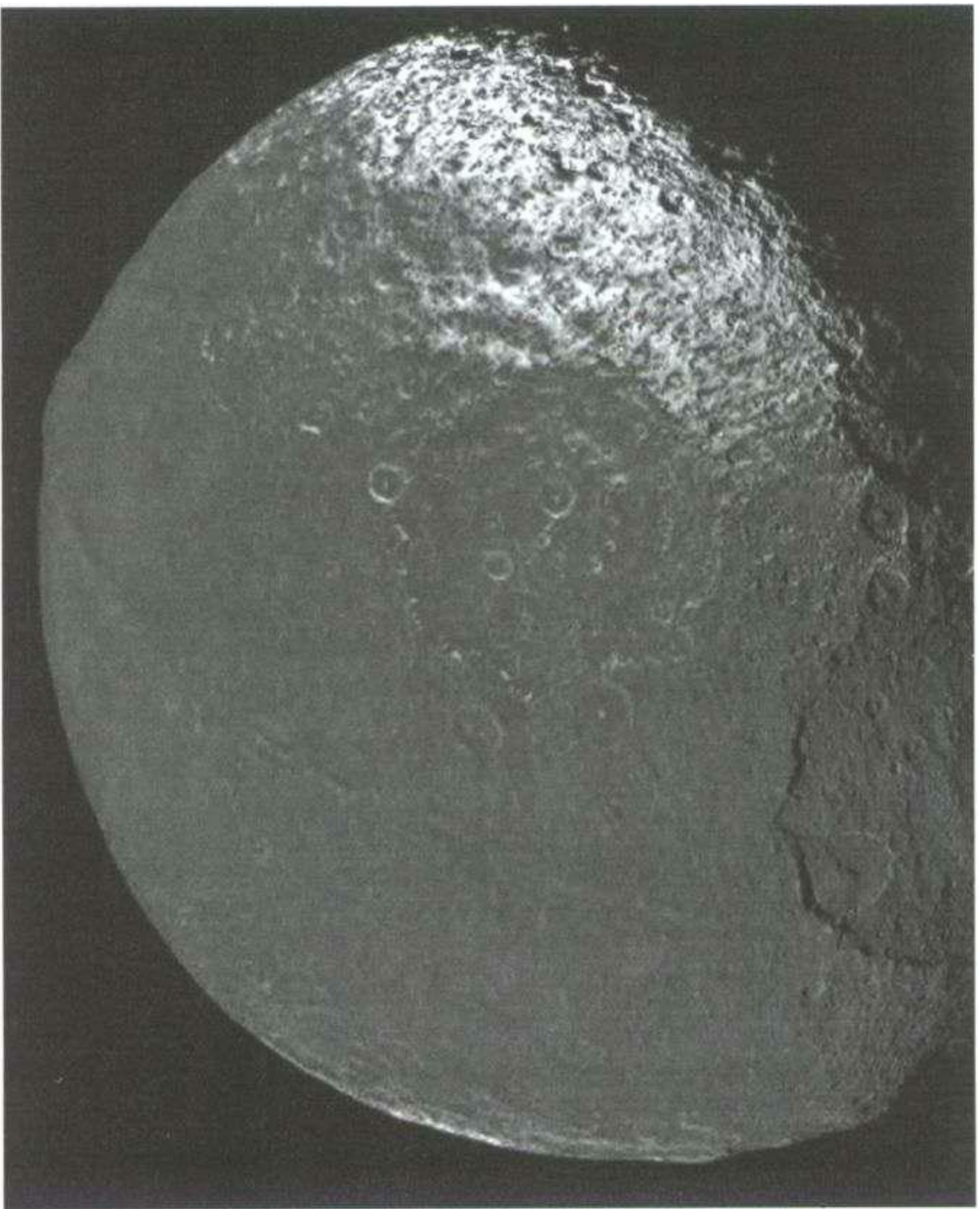

Hoagland observes that while Iapetus has obviously been subjected to a meteoric bombardment, “the larger structural geometry literally holding it together - on a variety of scales — is repeatedly revealed.”⁶⁴⁹

3. A Darkly Suggestive Coincidence? Iapetus' "Equatorial Ridge"

Another Cassini view of the Saturnian "moon" reveals an even more highly irregular feature on a supposedly "natural" object: a ridge or "wall" running the entire length of Iapetus' equator, in a *straight line*, a feature visible in the previous picture just below the two large (and perceptibly hexagonal) craters, and thrown into even more stark relief in the following close-up.

Iapetus' Equatorial "Ridge" In Close Up.

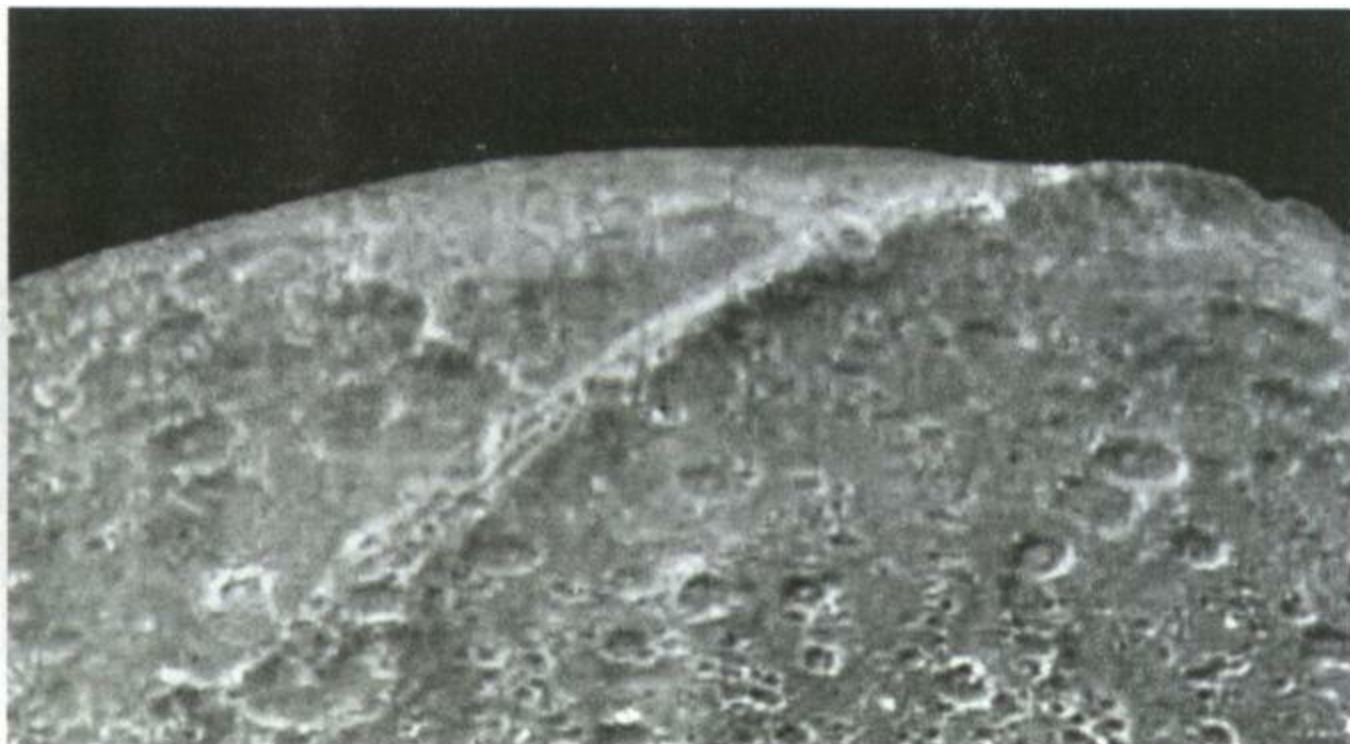

Again, close attention to this photograph will reveal two more features: (1) the hexagonal craters already previously mentioned, and (2) the fact that the equatorial "ridge" appears to be composed of three parallel components, a fact that will assume some importance subsequently. As for the ridge itself, it is estimated to be some six miles high, and of slightly greater width. This feature, notes Hoagland, is "*the greatest linear feature in the solar system,*" a fact that takes on some scientific urgency, because "there is no viable geological model to explain a *sixty thousand-foot-high, sixty-thousand-foot-wide, four million foot-long* "wall"... spanning *an entire planetary hemisphere*... let alone, located in the *precise plane* of its equator!"⁶⁵⁰ And what about those three parallel lines that appear to make up the "ridge"? Hoagland minces no words: "It is a well-known cliché that 'Nature doesn't usually create straight lines.' If that is true, then it certainly doesn't create *three* of them... - all running *parallel*, not only to each other, *but* to the literal equator of the planet."⁶⁵¹

4. Iapetus' Flat Plane Edges

As if this were not enough, the Cassini photographs revealed that Iapetus is not even a sphere at all, nor is it even a “squashed” sphere or ellipsoid. This feature was captured in all its obvious, though anomalous glory by a Cassini photograph taken when the “moon” was lit by reflected light from Saturn.

*Iapetus' Straight Plane Edges*⁶⁵²



Another view of these straight edges may be seen from yet a different point of view in a close-up photograph.

Iapetus' Straight Edges

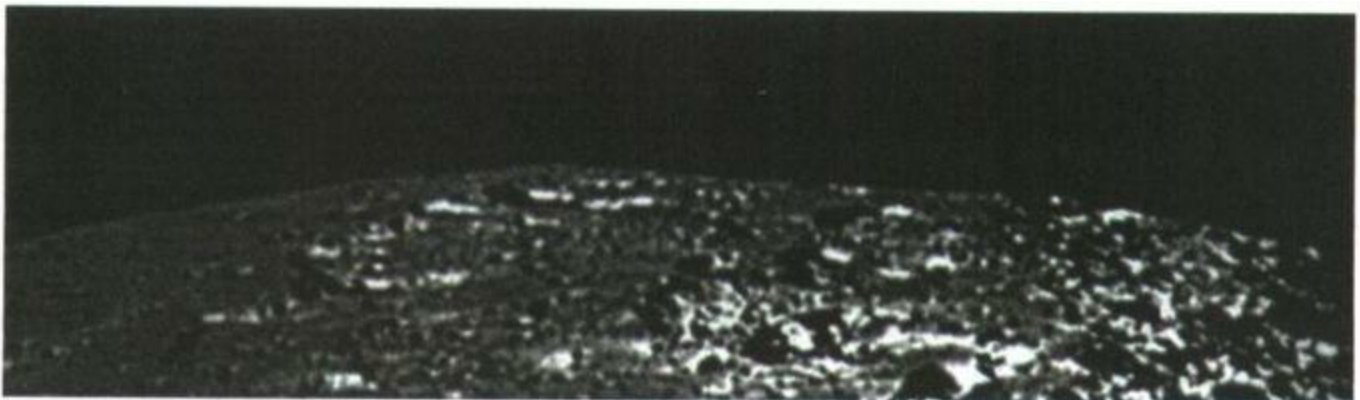

Looking at the horizon carefully, these straight edges are clearly visible once again. Iapetus is, on

other words, *not* a sphere nor even an ellipsoid. Or as Hoagland quips, “Needless to say - natural planets or satellites do NOT come with sharply-defined ‘straight edges!’”⁶⁵³ And these effects are again not due to any photographic defect. To drive this point home, Hoagland cites NASA’s own press release.⁶⁵⁴

Whatever Iapetus may be, it is clearly *not* a moon, a natural satellite. It is an artificial body - of immense size to be sure — placed in an artificial orbit around Saturn. Hoagland observes that the fact that NASA had the Cassini probe take over a hundred distant images of the “moon” indicated “that NASA also strongly suspected... what we’ve just discovered: that Iapetus, for *some* reason, is NOT a ‘spherical’ moon...In fact...that it’s not a ‘moon’ at all!”⁶⁵⁵

But from the standpoint of this study and of the Cosmic War Hypothesis it advances, Iapetus must surely be understood as corroborative evidence that the participants in that war, as indicated by the myths themselves, included Saturn, for now with Iapetus, we have clear evidence of a civilization, and of a technology, sufficiently advanced to wage war of that destructive a nature. This does not, however, imply that Iapetus was a component in whatever dreadful arsenal was used, but merely that a technology once existed sufficient to that task.

D. Hoagland's Three Hypotheses For Explaining lapetus

1. The “Ark” Hypothesis

While any survey of Hoagland’s *Moon With A View* paper could not possibly do it justice, no survey of the Iapetus anomalies that he so carefully catalogued in the over two hundred pages of analysis in that paper would not be complete without a brief mention of his own hypotheses for explaining the presence of this most extreme of all the anomalies in the solar system. Hoagland boils the main points of his argument for Iapetus’ artificial origins down to three basic facts, or as he calls them, “exhibits”:

Exhibit #1: the baffling, highly geometric, precisely equatorial ~60,000-foot-high “Iapetus Wall.”⁶⁵⁶

Exhibit #2, the equally astonishing, equally unnatural *rectilinear geometry* - evident all across the surface of this “moon.”⁶⁵⁷

Exhibit #3, without doubt our most astonishing Iapetus discovery - unique (so far...) in the entire solar system:

That, instead of being *spherical* - as natural moons larger than about 250 miles across *must* be (due to inexorable gravitational contraction) - the overall 900-mile-wide form of Iapetus is *highly geometric...* specifically, apparently an eroded *truncated isocahedron!*⁶⁵⁸

Viewing this planetary anomaly against the background of Van Flandern’s Exploded Planet Hypothesis, Hoagland advances his first hypothesis:

That, this extraordinary object was deliberately *constructed* as an “ark” — an artificial, world-sized spacecraft, designed to rescue as many as possible from the imminent, hyperdimensional explosion of *an entire world*, the destruction of a former major member of the sun’s planetary system which now *no longer exists*: Planet V. An event which would have inevitably, disastrously, affected the very existence of even an extremely advanced, *solar system wide* civilization...which we (and others) - based on a myriad of accumulating evidence - have proposed arose long before us...literally *millions* of years ago.⁶⁵⁹

But there is another, more disturbing possibility, one that perhaps the reader has already recognized, an imagery that comes from our own contemporary “mythologies”, and the fertile story-telling imagination of one of film-making’s most celebrated producers and directors...

2. The “Death Star” Hypothesis

Hoagland was not oblivious to this striking similarity, and in fact, captured the stunning nature of his next hypothesis in a very haunting visual comparison:

Hoagland’s Iapetus-Death Star Comparison

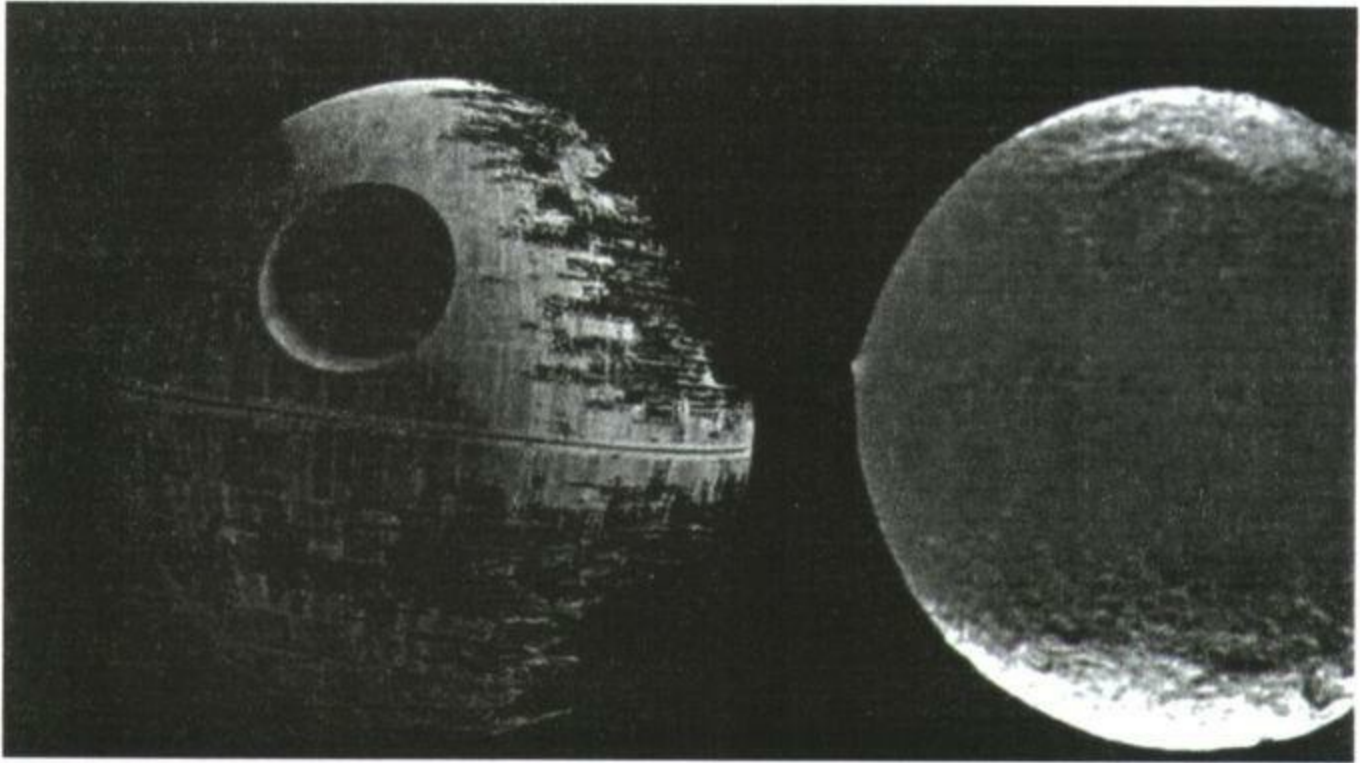

I have to confess that when I first saw this comparison on Hoagland’s website I was literally stunned. Even Hoagland had to ask an additional question at this point, not only wondering about what Arthur C. Clarke knew and when he knew it, but what *Star Wars* producer and director George Lucas knew, and when *he* knew it. As I have mentioned elsewhere,⁶⁶⁰ there are a whole host of parallels between the *Star Wars* “mythology” and that of the ancient myths themselves. Even “Anaken Skywalker’s” first name is a rough assonance on the Sumerian term “Anunnaki,” the beings who in Sumerian mythology came down from heaven and created mankind and subsequently taught him civilization.

Hoagland puts the case for his second hypothesis, his “Death Star” hypothesis, this way: Iapetus

Was indeed a “Deathstar world” — created as an instrument of war by that same civilization (which is *still* humans’ primary occupation, isn’t it?) - an “instrument” then used in some unimaginable conflict in this solar system a long, long time ago....

That Iapetus may somehow have even been instrumental in creating the almost unimaginable holocaust — a literal “war in Heaven” — which ultimately resulted in the *deliberate* destruction of that same doomed world ... with Iapetus itself caught by the aftermath. As an eternal silent tomb, forever trapped now in a permanent, unique orbit around Saturn....⁶⁶¹

At this juncture, Hoagland mentions his third, and most favored, hypothesis, dismissing the other two for their lack of sufficient explanatory power.

3. The “Temple” Hypothesis

This third hypothesis is that Iapetus was designed as a kind of “temple world” and placed in its precise orbital positioning to model, and “sacralize” various “hyper-dimensional” physics and mathematics. In short, it is the geometries present on Iapetus and in its orbital mechanics that the “rescue ark” and “deathstar” hypotheses cannot explain.⁶⁶²

There is much to commend this last hypothesis, including something that Hoagland does not mention, though it is clearly implied from his extensive remarks throughout his paper, and it was surely in his mind when he proposed this hypothesis, and that is that the “Temple Hypothesis” would certainly square with the type of religious world-view evident in the ancient myths we have examined in this book, and with the preoccupation of Mesopotamian, Egyptian, and later, Graeco-Roman civilizations to build temples embodying precisely such mathematical relationships. This, the “Ark Hypothesis” cannot do.

But I am bold to suggest that his “Deathstar” hypothesis *can* account for these geometries, for as has been repeatedly argued not only here but in my previous books, any weapons system based on scalar physics would seek to embody as many geometric analogues of local celestial systems and their mechanics into its structure as possible, *in order to make it the most efficient resonator of those local space-time geometries*. One would come to *expect* such redundancies, and such orbital mechanics, for they would serve a *functional* purpose for the weapons system. Similarly, as we have also pointed out in this book, such a physics can also be made the basis, in one and the same system, for a powerful interstellar communications network. So yet another possibility is that Iapetus may form some component or “base of operations” in such a network.

Moreover, Hoagland’s “Deathstar” hypothesis shares something in common with his “Temple Hypothesis” and that is that there is a mythological context in which it makes perfect sense: the war of the Titans, the giants of old, to overthrow the “first god” Kronos, Saturn. This fact, coupled with the fact observed earlier in this book that Saturn is often, for some reason lost to history, portrayed in conjunction with Mars, the god of war. Viewed in this light, Hoagland perhaps may have abandoned his “Deathstar” hypothesis too quickly.

In any case, our examination of the extra-terrestrial evidence for an ancient interplanetary civilization and war is now complete. Only one final problem remains: the antiquity of its observers and combatants themselves...

THE ANTIQUITY OF MAN...OR OF WHOMEVER

“From the Vedic literature, we derive the idea that the human race is of great antiquity. For the purpose of conducting systematic research into the existing scientific literature on human antiquity, we expressed the Vedic idea in the form of a theory that various humanlike and apelike beings have coexisted for long periods of time. ”

Michael A. Cremo⁶⁶³

Any attempt to summarize the voluminous and well-documented research of Michael A. Cremo and Richard L. Thompson in one short chapter is doomed to failure at the outset. Their magisterial work on alternative paleontology and anthropology, *Forbidden Archeology*, runs a little over nine hundred pages. Its “condensed” version, *The Hidden History of the Human Race*, is itself over three hundred.

However, one may approach their work from the standpoint of the Cosmic War Hypothesis, and what it implies for their own thesis. Cremo and Thompson approached their work in the broadest possible sense, as a “sociological, philosophical, and historical critique of the scientific method, as applied to the question of human origins and antiquity.”⁶⁶⁴ Their basic thesis is that humanity is of far greater antiquity than the standard academic models will allow, hence, this places them in direct conflict with modern evolutionary theory. Again, this is not the place to examine their critique of that theory; however, as a result of their extensive review of the archeological evidence in the literature, oftentimes dating back a century or more, they conclude that the “facts” of evolutionary theory “turn out to be networks of arguments and observational claims.”⁶⁶⁵

A. A Brief Review of Cremo and Thompson's Critique of Evolutionary Theory

One of the dogmas of the standard model concerns the discovery of Java Man, a “protohuman hominid” that was discovered

In Middle Pleistocene deposits generally given an age of 800,000 years. The discovery became a benchmark. Henceforth, scientists would not expect to find fossils or artifacts of anatomically modern humans in deposits of equal or greater age. If they did, they (or someone wiser) concluded that this was impossible and found some way to discredit the find as a mistake, an illusion, or a hoax. Before Java man, however, reputable nineteenth-century scientists found a number of examples of anatomically modern human skeletal remains in very ancient strata.⁶⁶⁶

After citing a series of reports and papers from such scientists concerning human remains from a date prior to the “evolutionary benchmark” of Java man, Cremo and Thompson observe that a similar set of papers and reports exists in support of the standard theory. One is left with the unpleasant alternative of rejecting both types of reports, or accepting both.

However, if one accepts the first set of reports,

Then we must accept the existence of intelligent, tool-making beings in geological periods as remote as the Miocene, or even the Eocene. If we accept the skeletal evidence presented in these reports, we must go further and accept the existence of anatomically modern human beings in these remote periods. This not only contradicts the modern theory of human evolution, but it also casts grave doubt on our whole picture of the evolution of mammalian life in the Cenozoic era.⁶⁶⁷

The Miocene era is generally understood to run from approximately 25 to 5 million years ago, and the Eocene from 50 or 55 to 45 million years ago. Thus, Cremo and Thompson's work has the happy benefit of providing its readers with a veritable catalogue of “pre-evolutionary” evidence, widely reported in the literature of the day, that subsequently was forgotten, or worse, hushed up. In any case, they outline a substantial case that mankind is indeed of far greater antiquity than modern standard models will countenance.

For the Cosmic War Hypothesis, however, the antiquity of mankind is a given. What must be explained, rather, is the level of cultural achievement of this “paleoancient man,” or lack of it, for as we have already seen, the War Hypothesis demands that at some point between 3,200,000 and 65,000,000 years ago, there existed a sufficiently advanced culture - human or otherwise — in order to wage the war, if one accepts the dates of Van Flandern's Exploded Planet Hypothesis as chronological benchmarks. This problem is acknowledged by Cremo and Thompson themselves in no uncertain terms, even though they most decidedly are *not* concerned with any version of the Cosmic War Hypothesis.

Up to this point, most of the evidence we have considered gives the impression that even if humans did exist in the distant past, they remained at a somewhat primitive level of cultural and

technological achievement. One might well ask the following question. If humans had a long time to perfect their skills, then why do we not find ancient artifacts indicative of an advancing civilization?

In 1863, Charles Lyell expressed this doubt in his book *Antiquity of Man*: “Instead of the rudest pottery or flint tools... we should now be finding sculptured forms, surpassing in beauty the master-pieces of Phidias or Praxiteles; lines of buried railways or electric telegraphs, from which the best engineers of our day might gain invaluable hints; astronomical instruments and microscopes of more advanced construction than any known in Europe, and other indications of perfection in the arts and sciences.”⁶⁶⁸

Cremo and Thompson then go on to list a very suggestive catalogue of anomalous archeological artifacts that would seem to indicate *some* level of technological sophistication, even if not “astronomical” or “microscopic” devices, although as they also observe, such artifacts are very rare, and dispersed throughout the world.

B. Anomalous Finds of Great Antiquity Indicating the Existence of Technology

1. The Aix-en-Provence Find

One such discovery that Cremo and Thompson relate is the discovery made by French laborers from 1786 to 1788 in Aix-en-Provence, and recounted by the Count Bournon. Having dug to a depth of *fifty feet through solid limestone*, the workers then came upon a chamber, in which they discovered tools, hammers, coins, and other standard mason's equipment. Some of the stones found in the chamber had already been worked. The *American Journal of Science* in 1820 cited the Count Bournon's concluding words concerning the implications of this discovery: "The presence of man had then preceded the formation of this stone, and that very considerably since he was already arrived at such a degree of civilization that the arts were known to him, and that he wrought the stone and formed columns out of it."⁶⁶⁹

2. Finds Reported in American Scientific Journals

In 1831, *The American Journal of Science* was at it again, reporting the discovery of raised characters on a block of marble taken from a quarry near Philadelphia, from a depth of 60-70 feet. The characters once again suggested an origin by humans who had worked the stone in the distant past.⁸

As no evolutionary college of cardinals existed at the time to suppress archeological Galileos making inconvenient discoveries, even a prestigious journal such as *Scientific American* could get in on the act. In its June 5, 1852 issue, the journal ran an account of a discovery of truly “paleoancient” proportions:

A few days ago a powerful blast was made in the rock at Meeting House Hill, in Dorchester, a few rods south of Rev. Mr. Hall’s meeting house. The blast threw out an immense mass of rock, some of the pieces weighing several tons, and scattered fragments in all directions. Among them was picked up a metallic vessel in two parts, rent asunder by the explosion. On putting the two pieces together it formed a bell-shaped vessel, 4-1/2 inches high, 6-1/2 inches at the base, 2-1/2 inches at the top, and about an eighth of an inch in thickness. The body of this vessel resembles zinc in color, or a composition metal, in which there is a considerable portion of silver. On the side there are six figures or a flower, or bouquet, beautifully inlaid with pure silver, and around the lower part of the vessel a vine, or wreath, also inlaid with silver. The chasing, carving, and inlaying are exquisitely done by the art of some cunning workman. This curious and unknown vessel was blown out of the solid pudding stone, fifteen feet below the surface.... There is not doubt but that this curiosity was blown out of the rock, as above stated.... The matter is worthy of investigation, as there is no deception in the case.⁶⁷⁰

Cremo and Thompson state the implications in no uncertain terms:

According to a recent U.S. Geological Survey map of the Boston-Dorchester area, the pudding stone, now called the Roxbury conglomerate, is of Precambrian age, *over 600 million years old. By standard accounts, life was just beginning to form on this planet during the Precambrian. But in the Dorchester vessel we have evidence indicating the presence of artistic metal workers in North America over 600 million years before Leif Erickson.*⁶⁷¹

In other words, before there were even dinosaurs, someone of intelligence, with a culture and a technology to produce such an object of art, existed on planet Earth, and all this from *Scientific American*, before the theory of evolution, and before it was taken over by that theory’s cardinalate.⁶⁷²

3. The Smithsonian's 200,000 Year Old Coin

Another strange find was reported in 1871 by William E. Dubois of the Smithsonian Institution. One of these was a small copper coin covered with strange markings and an unidentifiable figure. The coin was retrieved by a man drilling a well from a depth of 125 feet, through 3 feet of soil, “10 feet of yellow clay; 44 feet of blue clay; 4 feet of clay, sand, and gravel; 19 feet of purple clay; 10 feet of brown hard pan; 8.5 feet of green clay; 2 feet of vegetable mould; 2.5 feet of yellow clay; 2 feet of yellow hard pan; and 20.5 feet of mixed clay.”⁶⁷³ The Illinois State Geological Survey's estimates for the age of deposits at the 114 foot level was that they were formed at the “Yarmouthian Interglacial ‘sometime between 200,000 and 400,000 years ago.’”⁶⁷⁴ This is intriguing, because it corresponds with the same approximate time frame given in the Sumerian Kings List of the arrival on Earth of the Anunnaki, and the time that they allegedly reigned on Earth prior to the Flood: 241,200 years.

But there were other interesting things about the coin than its age. Dubois noted that the coin was polygonal, its inscriptions were in no recognizable language, and most importantly, since it was of uniform thickness, Dubois concluded that it must have “passed through a rolling-mill...”⁶⁷⁵ This flies squarely in the face of standard models in any number of ways, from the existence of such technology, to the fact that *Homo sapiens sapiens* is not believed to have lived “much earlier than 100,000 years ago,” to the fact that metal coins were thought to be used only after the eighth century BC in Asia Minor.⁶⁷⁶

400,000-200,000 Year Old Coin from Illinois: the Writing is not from any known ancient language
⁶⁷⁷



4. The Nampa Figurine, and Technology in the Coal

Another anomalous find was discovered in 1889 at Nampa, Idaho at a depth of 300 feet, again from a well-boring. The figurine is an anatomically correct depiction of the modern human form, of a female, and of very refined artistic technique. The figurine is only approximately 1 ½ inches tall, making the refinement of the artistic technique it displays the more remarkable. The strata from which the little female figure came dates from the Plio-Pleistocene age, making it approximately 2,000,000 years old!

Another remarkably old object was discovered by an Illinois housewife as she was breaking up coal to place in her coal scuttle. On breaking up one lump, she discovered a gold chain of apparently antique design was partially embedded in one of the fragments. After the woman's death the chain could not be traced, but the layer of coal from which it allegedly came made the chain between 260-320 million years old.⁶⁷⁸ A similar incident occurred in Oklahoma, when an iron pot was discovered embedded in coal that had been broken up. The coal was traced to its original mine, where the strata from which the pot came dated to 312,000,000 years ago.⁶⁷⁹ Again the implications of these discoveries would be dismissible if there was only one of them, but two such discoveries in widely separated regions, from approximately the same time period indicate that someone with technological metal-working skills existed on planet Earth a very long time ago.

5. Footprints of a Paleancient Civilization

Two enormously anomalous discoveries were made in the American Southwest. On October 8, 1992 the “American Weekly” section of the *New York Sunday American* carried an article entitled “Mystery of the Petrified ‘Shoe Sole’ 5,000,000 Years Old.” The article was by Dr. W.H. Ballou who reported a discovery by the geologist John Reid, who was digging for fossils in Nevada. Much to his surprise, Reid discovered a very strange “fossil” indeed, that of the sole print of a shoe in rock that was at least 5,000,000 years old!⁶⁸⁰ But five million years proved to be far too *late* a date for the print, since the rock on which it was found was from the Triassic period, usually dated to some 213-248 million years ago.

213-248 Million Year Old Shoe Sole Print from Nevada ⁶⁸¹



Another very controversial find is the so-called Meister shoeprint, discovered in 1968 in Utah by William J. Meister, an amateur fossil hunter and collector. This shoeprint was found in Cambrian shale near the town of Antelope Spring, Utah. The print occurs in rock that is over 505 million years old. Of course, as Cremo and Thompson point out, the find was quickly dismissed, as scientists closed ranks and came up with a variety of sound bites attacking “creationists” and “flat earthers,” even after one evolutionary biologist admitted he had not actually seen the print firsthand himself. While this is not the place to survey the controversy surrounding this incredible print,⁶⁸² Cremo and Thompson admit that the case remains ambiguous, but unlike the dogmatists in the university science faculties, they “suggest... that the resources of empirical investigation have not yet been exhausted and that the Meister print is worthy of further research.”⁶⁸³

*The Meistner Shoe Print: If Genuine, this Fossilized Shoe Print would be over 505 Million Years Old*⁶⁸⁴

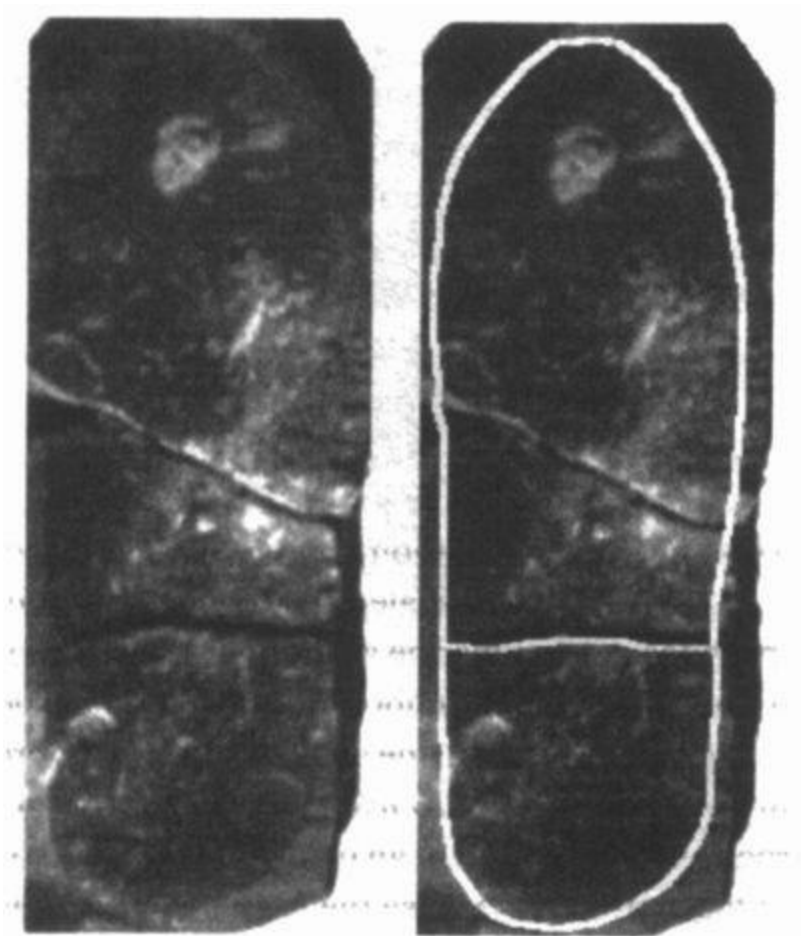

6. Artifacts that are Products of Technology

In 1968 Y. Druet and H. Salfati stated that they had found semi-ovoid metallic tubes “of identical shape but varying size in Cretaceous chalk” in a quarry near Saint-Jean de Livet in France. This would make the mysterious tubes, the obvious products of a technology, at least 65,000,000 years old. The significance of the date, by now, should be obvious, for it is the date of Van Flandern’s first planetary explosion.

An even more anomalous find occurred when curious metallic spheres were found in a mine in Ottosdal in the Transvaal in South Africa. According to Roelf Marx, “curator of the museum of Klerksdorp, South Africa, where some of the spheres are housed,” the metallic spheres “are a complete mystery. They look man-made, yet at the time in Earth’s history when they came to rest in this rock no intelligent life existed.”[685](#)

Sketch of 65,000,000 Year Old Metallic Tubes Found in Chalk in France [686](#)

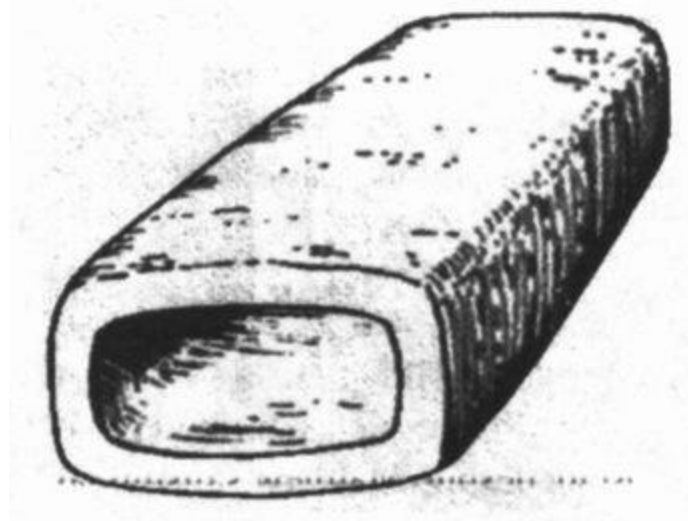

Two of these little balls show features we’ve encountered before. One of them, a metallic sphere, was discovered in a layer of Precambrian deposits, making it some 2.8 *billion* — that’s billion with a “b” — years old! This strange sphere has another oddity: three parallel grooves running around its equator:

2.8 Billion Year Old Metallic Sphere with Three Equatorial Grooves, Found in the Transvaal, South Africa [687](#)



Yet another of these spheres exhibits a single equatorial groove, and a small “pit” or “crater” just above this groove:

South African Metallic Sphere with Single Equatorial Groove and Small “Pit” or “Crater” Like Feature above it [688](#)



We’ve seen something like these features before, *on Saturn’s “moon” Iapetus!* While there is, of course, no evidence to connect the little South African metal balls with that enormous and most probably artificial object orbiting Saturn, the resemblance is all too palpable, and raises intriguing possibilities. Might we be looking, for example, at a child’s set of *toy models*? While we will probably never know the answer to that or similar questions, the fact remains that the resemblance is

there.

But more importantly, the fact that these little spheres even exist is yet another piece of evidence that *someone* intelligent, possibly human, possibly not, was on this planet *a very very* long time ago indeed.

C. Some Radical Speculations Courtesy of the Cooper-Cantwheeler MAJIC-12 Documents

1. Human Origins and the “Celestial Extent” of Humanity or its Genus

This short review of Cremo and Thompson’s massive catalogue of evidences for the great antiquity of mankind has indicated that someone of intelligence was on Earth *during the time periods hypothesized for the great Cosmic War*. Moreover, the dispersion of this evidence, from North America to Europe to South Africa, slight as this account of evidence reviewed here is, tends to support the view that this paleoancient civilization was at least fairly well-dispersed over the surface of the planet. And the great antiquity of some of these anomalous discoveries also suggests an answer to Lyell’s question that began our review of Cremo and Thompson’s evidences. Lyell, as was seen, asked why there was not evidence of a great, advanced, lost civilization. And the answer that Cremo and Thompson’s own catalogue of anomalies seems to suggest is, that there is so little because that civilization was of such extreme antiquity that very little evidence is *likely* to remain, and if it does, it lies buried beneath hundreds of feet of geological strata. To put it succinctly, we merely haven’t dug deep enough.

These evidences also raise another equally if not more important question: *Who* was present on Earth that long ago? The answer of many of the ancient mythologies would be that the “sons of heaven” or the “Anunnaki” or the “*b’nai Elohim*,” the “sons of God,” were.

However, a slightly different - though not ultimately contradictory — answer is suggested by a most unusual source. Readers of my books on World War Two Nazi secret weapons research, *Reich of the Black Sun* and *The SS Brotherhood of the Bell*, will recall that I analyzed the so-called Cooper-Cantwheel series of the MAJIC-12 or MAJESTIC-12 documents. One of those documents which will be our focus here, was called the “Project White Hot Intelligence Estimate (Preliminary).” This document is divided into three sections, the first section dealing with the crash and recovery of bodies at the celebrated Roswell crash, the second section being a “Technical Evaluation(Preliminary)”, and the third section entitled “Scientific Probabilities.”⁶⁸⁹

It is part three that interests us here. I will cite the portion of this section of the document that concerns us at length to show the context, italicizing those portions of the document that provide a radical answer to our question, “Who was here that long ago?”

1. Based on all available evidence collected from recovered exhibits currently under study by AMC, AFSWP, NEPA, AEC, ONR, NACA, JRDB, RAND, USAAF, SAG, and MIT, deemed extraterrestrial in nature.

Thus far, the document sounds like it is supporting the idea that the bodies allegedly recovered at the Roswell crash are non-human extraterrestrials, right? Read further:

This conclusion was reached as a result of comparisons of artifacts ~~from the Missouri~~⁶⁹⁰ discovery in 1941. The technology is outside the scope of US Science, even that of German rocket and aircraft development.

2. Interplanetary space travel is possible provided adequate funding, necessary resources are made available, and national interest is piqued.

5. *Human origins may not be constrained to one planet. Our genus may be found among solar systems similar to our own.*
6. *The laws of physics and genetics may have a genesis in a higher, structured order that once (sic) previously thought.*⁶⁹¹

Statements 5 and 6 occur in a context in the document *after* autopsies are allegedly performed on the “recovered bodies” from the UFO crash. While most people rush to see in these documents a confirmation of the extraterrestrial hypothesis, what they miss are the implications of these two highly significant statements, for if the document is genuine - and assuming for the sake of argument that it is - then it means that the recovered bodies were so sufficiently like us that they are referred to as “human,” and thus the document raises the question that the document itself addresses: that the genus within which *homo sapiens sapiens* fits may, and evidently *does*, exist on other planets.

And thus one is led to point 6 in the document, and to its astonishing conclusion: “The laws of physics and genetics may have a genesis in a higher, structured order (than) once previously thought.” What the document is in fact suggesting here is a degree of scientific sophistication - apparently suggested to the experts examining the recovered components and bodies from the crash — that displays a union of physics and biology in a higher theoretical order. This is exactly the same sort of thing that was implied by the clues upon which we speculated on what really constituted the Tablets of Destinies. That is, that evolutionary processes that lead to the development of particular *kinds* of intelligent life - recall that comment about the human “genus” in point 5 — might be derivable from the same sort of formally explicit laws that the *physical technology* of the recovered craft suggests.

Now this is interesting, because it flies in the face of the physics technology that is actually *described* in the document, which, as I point out in *Reich of the Black Sun* and in *The SS Brotherhood of the Bell*, is simply *insufficient* to indicate a craft capable of interplanetary, much less interstellar, travel. In fact, as I argue in those books, the technology surveyed in the Cooper-Cantwheel MAJIC-12 documents sounds all too *human* and *terrestrial*, indeed, it sounds only modestly more advanced than the technology of the late 1940s, when this “advanced craft” crashed!

So in other words, these conclusions in points 5 and 6 *exceed the stated scope of the evidence cited internally in the document itself*, and this implies that something about the technology that was *omitted* from the document suggested to the technical analysts involved in the recovery that they were dealing with something *paradoxically both humanly terrestrial and humanly extraterrestrial*.

In any case, the document makes the astonishing suggestion that humanity or at least its “genus” *may possibly be found on a multitude of worlds and may not be limited to our own solar system*.

2. *The Two Space Programs Hypothesis and Scientific Suppression*

These speculations return us once again to the idea of two space programs, a covert and an overt one. Many researchers who have studied the phenomena of anomalous and artificial artifacts on other planets, such as Richard Hoagland, Mark Carlotto, and others have often commented on the fact that NASA and other agencies are apparently covering up, or tampering with or otherwise altering the publicly available data and photographs. Others, such as Lt. Col. Tom Bearden, or physicists Tom Vallone or Paul LaViolette, have noted a similar cover-up in place in the suppression of alternative energy inventions or theoretical papers. And, in this chapter, we have encountered evidences of the antiquity of mankind (or of “*whomever*” as I have indicated in the chapter title) which is ignored or deliberately forgotten and suppressed by the scientific community.

We thus have the following areas in which a cover-up, tampering, or suppression of the evidence is visible, or at least suggested:

1. A cover-up of anomalies indicating intelligent design on other planets within our solar system, which may extend to a cover-up of data concerning the actual geology, geography, and physics of celestial bodies. Moreover, this cover-up may extend to the concealment of the true purpose of space programs, which may be to recover whatever ancient advanced technology as may be found on nearby celestial bodies;
2. A cover-up of alternative conceptions and technologies in physics since at least the early nineteenth century, which may lead both to greater energy efficiency, and to weapons of horrendous power;
3. A cover-up of anomalous data concerning the great antiquity of mankind, or of “*whomever*,” on Earth, and of the apparent technological sophistication that was achieved, a cover-up usually made in aid of defending the theory of evolution. In fact the real motivation for doing so may not lie in defending the leaky theory of evolution, but diverting attention from the possibility that very advanced ancient technologies may exist. Moreover, this cover-up may be due - as the MAJIC-12 documents suggest - to the fact that “*insiders*” possess information suggesting that human origins are interplanetary in nature.

If one looks at this list of possibilities and speculations, then it is clear that the Cosmic War Hypothesis touches on each of the three main areas. This in turn suggests that the Cosmic War Hypothesis itself may be one of the hidden motivations for each of the three areas of cover-up. After all, if there was such a war, it implies a celestial extent to humanity, or “*whomever*,” and a sophistication of technology and a potential for destruction that we can scarcely imagine. If one adds into that volatile mix the clear indications of our most ancient myths, that there was also an ancient and preternaturally malign intelligence behind the most primordial revolt, then it is a frightening scenario indeed.

SUMMARIES AND FINAL SPECULATIONS

“As to the fight by the Persea tree hard by, in Annu, it concerneth the children of impotent revolt when justice is wrought upon them for what they have done. As to (the words) ‘that night of the battle,’ they concern the inroad (of the children of impotent revolt) into the eastern part of heaven, whereupon there arose a battle in heaven and in all the earth. ”

The Egyptian Book of the Dead, Spell XVII[692](#)

This book has outlined the prima facie case for a paleoancient Cosmic War within our own solar system, a case based in part on modern science, on ancient texts, and on the peculiar interface that seems to exist between the two, allowing reconstructions of an ancient paleophysics from suggestive passages in those texts.

For purposes of the chronological benchmarks of that war, Dr. Tom Van Flandern’s two exploded planet events at 65,000,000 and 3,200,000 years ago were viewed as the benchmarks around which to fasten the events of the wars in the pantheon alluded to in the Mesopotamian texts examined here. As was also seen, the 3,200,000 year benchmark had textual and mythological corroboration both from the Vedic tradition of the great “yugas” and from the Sumerian Kings List.

A physics sufficient to the task of significantly scarring a planet surface was found in the plasma physics of Alfvén and Peratt, and the latter’s corroborating evidence of petroglyphs was found to support human observation of massive plasma discharges and instabilities in very ancient times, though certainly not within the timeframe suggested by Van Flandern’s Exploded Planet Hypothesis in its original or revised versions. Moreover, as we saw, this physics would adequately explain the resemblance of Mars to the mythical motif of the “scarred warrior,” with its distinct large planetary feature of the Valles Marineris, which strongly suggests formation via a large electrostatic discharge. Its almost straight nature also suggests that this discharge was intelligently manipulated and steered - targeted would be a better word — across the surface of that planet.

This plasma physics in turn suggested disturbing ties to the wartime Nazi “Bell” project, as was seen, and also indicated deeper connections to scalar physics, a physics that, in the hands of Paul LaViolette’s exposition of pulsars, could be made to form a galactic communications grid, and could be made of sufficient power to explode a planet in a deliberate act of war, an act strongly suggested by the Enuma Elish and other Mesopotamian legends.

The exploded planet, of which Van Flandern believes Mars was once a satellite, was a large planet, of similar mass to Saturn, and very possibly solid and water bearing. And that implied in turn that it may have been home to intelligent life, life that we speculated was humanoid in nature, but of much larger physiology to accommodate the greater gravity. Ancient myths from the Sumerian to the

Greek to the Biblical traditions also record a race of giants that came from the heavens, and revolted against their gods or God, and fought a prolonged and destructive war. In the Sumerian and Biblical traditions, these giant creatures also intermarried with humans, and produced giant offspring. Corroborative evidence of the existence of extraordinarily large human giants was presented both from ancient and more modern times as a very loose corroboration both of the ancient legends, and of the speculation offered concerning the large inhabitants of that exploded and now missing planet.

The ancient Mesopotamian texts also make it clear that the war was fought over, and by means of, a hegemony-conferring technology called the Tablets of Destinies, a technology found to be paralleled in some Egyptian legends such as the Edfu building texts, the Egyptian Book of the Dead, and in legends surrounding the disappearance of Thoth's emerald or sapphire tablets. These Tablets were apparently connected to the stones of power, inventoried by Ninurta prior to the destruction of some, the preservation and the secreting-away of others. In this, the inventory of the stones resembles nothing so much as the post-World War Two behavior of the Allied powers inside of vanquished Germany, and lends the ancient myths an air of authenticity, as if they are dimly remembered historical events.

These Tablets of Destinies, as was also seen after careful examination of the complex of mythological symbols associated with them, were speculated to be the indexes of interferometric "gratings," the necessary targeting information or software, to be plugged into the hardware of a devastatingly power scalar weapon of mass destruction, whatever that weapon may have been.

The textual traditions and mythological symbols examined also pointed to certain combatants in this Cosmic War: the now missing and exploded planet, plus Mars, Saturn, the Moon of Earth, and the Earth itself. Corroborative evidence of the existence of artifacts of intelligent design was presented, from anomalous features on our own Moon, to the familiar, and not-so-familiar, anomalies on the surface of Mars, to the bold hypothesis of Richard C. Hoagland that Saturn's moon Iapetus itself appears to be one gigantic artificial satellite.

The Cosmic War Hypothesis also requires the presence of intelligent observers of the events described, not only on those planets, but on the Earth itself. In this respect evidence was presented from Cremona and Thompson's voluminous work on suppressed archaeological discoveries that suggest that modern man is of much greater antiquity than standard evolutionary biological, paleontological, and anthropological models will allow. Evidence was presented that *someone* intelligent, of human-like characteristics, existed on the Earth many millions of years ago, and in time frames that fell within the benchmarks of Van Flandern's Exploded Planet Hypothesis.

All this is to say, of course, that I believe that the Cosmic War Hypothesis has been made an adequate prima facie case, if not, perhaps, the best one that could have been made.

But in addition to all this, there are, of course, disturbing possibilities, and we have mentioned some of them throughout this work. But there are more, of the "what if" variety.

The Tablets of Destinies, and their counterparts, the Tablets of Thoth, were inextricably tied to Mesopotamia, and to Egypt. And, via the "Mountains \approx Celestial Bodies \approx gods \approx Pyramids" formula, they are inextricably tied to the artificial mountains - the pyramids and ziggurats - of those areas. We have speculated in this work, therefore, that perhaps some of their remaining components lie secreted beneath the sands and silts of the ages of those places.

And this point raises those disturbing possibilities, possibilities that someone, somewhere, may be looking for them. I hinted at these possibilities only obliquely when I wrote in my book, *The Giza Death Star*, the following passage:

From the 19th and on into the 20th centuries until the outbreak of (World War Two), American and German scholars poured over Near Eastern archaeological sites with a view to but one thing: proving their pedigree and connection with those ancient societies. It was the first outbreak of the “culture war,” expressed in a kind of social imperialism as the ascendant Anglo-American culture and the ascending German culture each laid claim to a vaunted ancient pedigree. For the Anglo-Americans, the lineage ran from Egypt, to Greece, Rome, Britain, and finally to America. For the Germans, the lineage ran from Atlantis, to Sumer, to India, and finally to Germany. [693](#)

The search was, however, doomed so long as it was conceived as a search for true origins between Egypt and Sumer, as if the two cultures are opposed and unrelated entities. On the contrary, as we have seen, there is ample evidence to suggest that they each preserved, in their own ways within their own myths, an older stratum of histories about the Cosmic War, and the technologies with which it was fought.

But search nevertheless they did. And no nation more assiduously than did Germany, for Germany was the home, in that day, of some of the most renowned and famous Sumerologists and Assyriologists in the world. German orientophilia expressed itself popularly with translations of Mesopotamian myths into German. It is possible then, that during the crazed inter-war years of the Weimar Republic, with its numerous secret societies stressing an ancient super-race from which the Germans allegedly descended, that this expressed itself in the form of an organized effort to seek and recover those lost technologies. And in the milieu of the Third Reich, and Reichsführer SS Heinrich Himmler’s SS “occult and ancestral research bureau,” the notorious *Ahnenerbedienst*, the bureaucratic climate would certainly have existed for the type paleophysics interpretation of ancient texts as has been undertaken here. This would have led to a profound, and very secretive, German presence in what is now...Iraq.

Nazi interest in that country, then under strong British influence, dates back to the 1920s when the National Socialist party was still in its infancy. Not surprisingly, one finds the character of Detlef Schmude - a main player in the Nazi party’s secret society backer, the infamous *Thule Gesellschaft*, a member as well in Von Liebenfels’ Order of the New Templars (ONT) and an editor of the Thule Society’s magazine *Ostara* - settling in Tabriz, in neighboring Persia. There he based his next few years’ search for the “Hidden Masters.” Someone of Schmude’s importance and position within these groups suggests that he was the point man for gathering facts and information for them.

Then, in 1939 Admiral Wilhelm Canaris’ *Abwehrabteilung*, Germany’s military intelligence, dispatched Dr. Paul Leverkühn to the Middle East to cultivate allies among the Muslim populations under British rule or influence. His headquarters was also Tabriz, in Persia. But most interestingly, his most highly-placed recruit was none other than pro-Nazi Iraqi Prime Minister Rashid Ali overthrown two years later by the British invasion of Iraq.

Canaris’ network of *Abwehr* agents inside of Iraq was taken over by Himmler in 1944, after Canaris’ implication in the Bomb Plot against Hitler in July of that year. Strangely enough, Himmler

placed these agents under the control of none other than Baron Rudolf Von Sebottendorff, one of the principal founders of the *Thule Gesellschaft* to begin with and, like Schmude, a member of Von Liebenfels' Order of the New Templars! This implies that the *real* basis of Nazi networks in Iraq was grounded in the secret society network in the region, perhaps initiated by Schmude.

Yet another connection that must be mentioned is "Himmler's Rasputin," Karl Maria Willigut, a.k.a. Weisthor. In 1940 Willigut brought several archaeological discoveries that indicated man's presence in Iraq's Irbil province as far back as 10,000 B.C.

What happened to this Thule-SS network in Iraq after 1945 no one knows, however, it is interesting to note that Von Sebottendorff's body was found floating in the Bosphorus in Istanbul in 1945, after the war's end.

This, plus the fact that both Germany and France gave great archaeological assistance to Saddam Hussein's regime, and the fact that there is now an armed American and British presence in the country, strongly suggests that another agenda may have been at work besides the prevention of Hussein's acquisition of weapons of mass destruction or the spread of terrorism. Indeed, perhaps everyone was in search of weapons of mass destruction of a very *different* and much more ancient sort!

Then there is the peculiar behavior of the Egyptian government, building a wall around Giza...

Finally, there is America's recent announcement that it intended to go back to the Moon, and on to Mars, with manned space missions. The announcement came after a series of manned space flights by Red China, as if to say that America intended to continue its "monopoly" of those two planets, and of whatever might be on them.

It is as if the wickedness and evil of contemporary men of might, cloaked in their agencies of power, prestige, and privilege, were secretly groping and reaching out, with all the might and dark technological sophistication that modern man can muster, for that diabolical stone of exile, for the tablets that once conferred and may yet confer again to their possessors an almost universal mastery.

Caveat lector!

BIBLIOGRAPHY

- Acheson, Mel and Amy. "Thunderbolts of the Gods: Does Growing Evidence of an Electric Universe Reveal Previously Hidden Meaning in Ancient Mythology?", *Forbidden History: Prehistoric Technologies, Extraterrestrial Intervention, and the Suppressed Origins of Civilization*. J. Douglas Kenyon, ed. Rochester, Vermont: Bear and Company. 2005. ISBN 159143045-3.
- Alford, Alan F. *The Atlantis Secret: A Complete Decoding of Plato's Lost Continent*. Walsall, England: Eridu Books. 2001. ISBN 0-9527994-1-3.
- Alford, Alan F. *The Phoenix Solution: Secrets of a Lost Civilisation*. London: Hodder and Stoughton. 1998. ISBN 0-340-69615-X.
- Alford, Alan F. *When the Gods Came Down: The Catastrophic Roots of Religion Revealed*. London: Hodder and Stoughton. 2000. ISBN 0-340-69616-8.
- Bearden, Thomas E., Lt. Col (US Army Ret), PhD. *Gravitobiology*. Tesla Book Co. 1991.
- Bearden, Thomas E., Lt. Col (US Army Ret), PhD. *Oblivion: America at the Brink*. Santa Barbara, California: Cheniere Press. 2005. ISBN 0-9725146-2-7.
- Bearden, Thomas E., Lt. Col (US Army Ret.), PhD. "Maxwell's Original Quaternion Theory was Unified Field Theory of Electromagnetics and Gravitation," *Proceedings of the International Tesla Society*.
- Bearden, Thomas E., Lt. Col (US Army Ret.), PhD. *Energy From the Vacuum: Concepts and Principles*. Santa Barbara, California: Cheniere Press. 2004. ISBN 0-9725146-0-0.
- Bearden, Thomas E., Lt. Col. (US Army, Ret.), PhD. *Fer De Lance: Briefing on Soviet Scalar Electromagnetic Weapons*. Santa Barbara, California: Cheniere Press. 2002. ISBN 0-9725146-1-9.
- Boulay, R. A. *Flying Serpents and Dragons: The Story of Mankind's Reptilian Past*. Revised and Expanded Edition. Escondido, California: The Book Tree. 1999. ISBN 1-885395-38-8.
- Brian, William L. II. *Moongate: Suppressed Findings of the U.S. Space Program: The NASA Military Cover-up*. Portland, Oregon: Future Science Research Publishing Co. 1982. ISBN 0-941292-00-2.
- Budge, Sir E. A. Wallis. *Amulets and Superstitions: The Original Texts with Translations and Descriptions of a Long Series of Egyptian, Sumerian, Assyrian, Hebrew, Christian, Gnostic and Muslim Amulets and Talismans and Magical Figures, with Chapters on the Evil Eye, The Origin of the Amulet, The Pentagon, the Swastika, the Cross (Pagan and Christian), the Properties of Stones, Rings, Divination, Numbers, the Kabbalah, Ancient Astrology etc.* Oxford: Oxford University Press. 1930. Kessinger Publishing Reprint. ISBN 0-7661-5789-X.
- Budge, Sir E. A. Wallis. *The Egyptian Book of the Dead: (The Papyrus of Ani) Egyptian Text Transliteration, and Translation*. Mineola, New York: Dover Publications, Inc. 1967. ISBN 0-486-21855-X.
- Childress, David Hatcher. *Extraterrestrial Archeology*, Revised Edition. Kempton, Illinois: Adventures Unlimited Press. 2002. ISBN 00932813-77-1.

Childress, David Hatcher. *Lost Cities of North and Central America*. Kempton, Illinois: Adventures Unlimited Press. 1998. ISBN 0- 932813-09-7.

Cohen, David. "Plasma Blobs Hint at New Form of Life," *New Scientist*, 17 September, 2003.

Collins, Andrew. *The Gods of Eden: Egypt's Lost Legacy and the Genesis of Civilization*. Rochester, Vermont: Bear and Co. 2002. ISBN 187918176-2.

Cremona, Michael A., and Thompson, Richard L. *The Hidden History of the Human Race*. Los Angeles: Bhaktivedanta Book Publishing. 1999. ISBN 0-89213-325-2.

Dalley, Stephanie, trans. and ed. *Myths from Mesopotamia: Creation, the Flood, Gilgamesh, and Others*. Oxford: Oxford University Press. 2000. ISBN 0-19-283589-0.

De Santillana, Giorgio, and Von Dechend, Hertha. *Hamlet's Mill: An Essay on Myth and the Frame of Time*. Boston: Gambit Incorporated. 1969.

Dharma, Krishna (a.k.a. Kenneth Anderson), ed. *The Mahabharata*. Badger, California: Toeclight Publishing, Inc. 2000. ISBN 1- 887089-17-9.

Farrell, Joseph P. *Reich of the Black Sun: Nazi Secret Weapons and the Cold War Allied Legend*. Kempton, Illinois: Adventures Unlimited Press. 2004. ISBN 1-931882-39-8.

Farrell, Joseph P. *The Giza Death Star Deployed: The Physics and Engineering of the Great Pyramid*. Kempton, Illinois: Adventures Unlimited Press. 2003. ISBN 1-931882-19-3

Farrell, Joseph P. *The Giza Death Star Destroyed: The Ancient War for Future Science*. Kempton, Illinois: Adventures Unlimited Press. 2005. ISBN 1-913882-47-9.

Farrell, Joseph P. *The Giza Death Star: The Paleophysics of the Great Pyramid and the Military Compound at Giza*. Kempton, Illinois: Adventures Unlimited Press. 2001. ISBN 0-932813-38-0.

Farrell, Joseph P. *The SS Brotherhood of the Bell: The Nazis' Incredible Secret Technology: NASA's Nazis, JFK, and MAJIC-12*. Kempton, Illinois: Adventures Unlimited Press. 2006. ISBN 1 931882-61-4.

Gardner, Laurence. *Genesis of the Grail Kings; the Explosive Story of Genetic Cloning and the Ancient Bloodline of Jesus*. Gloucester, MA.: Fair Winds Press. 2002. ISBN 1-931412-93-6.

Goodgame, Peter. *The Giza Discovery*. www.redmoonrising.com.

Greer, Steven M., M.D. *Disclosure: Military and Government Witnesses Reveal the Greatest Secrets in Modern History*. Crozer: Virginia: Crossing Point Publications, Inc. 2001. ISBN 0 9673238-1-9.

Gunterbrock, Hans Gustav. "The Song of Ullikummi," *Oriental Institute*. New Haven, CT.: The University of Chicago Press, and The American Schools of Oriental Research. 1952.

Haas, George J., and Saunders, William R. *The Cydonia Codex: Reflections from Mars*. Berkeley, California: Frog, Ltd. 2005. ISBN 1-58394-121-5.

Hall, Manley P. *The Secret Teachings of All Ages: Reader's Edition*. New York: Penguin. 2003. ISBN 1-58542-250-9.

Henry, William. *One Foot in Atlantis: the Secret Occult History of World War II and Its Impact*

on New Age Politics. Anchorage, Alaska: Earthpulse. 1998. ISBN 1-890693-49-9.

Hoagland, Richard C. *A Moon With a View: or, What Did Arthur Know...And **When** Did He Know It?* www.enterprisemission.com/moon1.htm.

Hoagland, Richard C. *The Monuments of Mars: A City on the Edge of Forever*, Fifth Edition. Berkeley, California: Frog Ltd. 2001. ISBN 1-58394-054-5.

Jacobsen, Thorkild, trans and ed. *The Harps that Once...: Sumerian Poetry in Translation*. New Haven and London: Yale University Press. 1987. ISBN 0-300-07278-3.

Joseph, Frank. *The Atlantis Encyclopedia*. Franklin Lakes, New Jersey: New Page Books. 2005 ISBN 1-56414-795-9.

King, L. W. *Enuma Elish: the Seven Tablets of Creation*, Volume One. Escondido, California: The Book Tree. 1999. ISBN 1-58509-041-7.

Laszlo, Ervin. *Science and the Akashic Field: An Integral Theory of Everything*. Rochester, Vermont: Inner Traditions. 2004. ISBN 159477042-5.

LaViolette, Paul. *Subquantum Kinetics: A Systems Approach to Physics and Cosmology*. Alexandria, Virginia: Starlane Publications. 2003. ISBN 0-9642025-5-7.

LaViolette, Paul. *The Talk of the Galaxy: An ET Message for Us?* Alexandria, Virginia: Starlane Publications. 2000. ISBN 0-9642025-3-0.

Lerner, Eric J. *The Big Bang Never Happened: A Startling Refutation of the Dominant Theory of the Origin of the Universe*. New York: Vintage Books. 1992. ISBN 0-679-74049-X.

McCanney, James M. *Atlantis to Tesla: The Kolbrin Connection: The Science of Atlantis and Tesla are Recovered, Giving a Unique Untold View of Life on the Lost Continent, Ancient Spacecraft Design, Unlimited Electrical Power, and the Secret Societies*. Minneapolis, Minnesota: jimccanneyscience.com press. 2003. ISBN 0-9722186-4-5.

Peratt, Anthony L. "Characteristics for the Occurrence of a High-Current, Z-Pinch Aurora as Recorded in Antiquity," *IEEE Transactions on Plasma Science*, Vol. 31, No. 6, Dec. 2003, pp. 1192-1214.

Peratt, Anthony L. "Evidence for an Intense Aurora Recorded in Antiquity," *ICOPS 2003: The 30th Annual International IEEE Conference on Plasma Science*, June 3-5, 2003.

Quayle, Stephen. *Genesis 6 Giants: Master Builders of Prehistoric and Ancient Civilizations*. Bozeman, Montana: End Time Thunder Publishers. 2005. No ISBN number.

Reymond, E. A. E. *The Mythical Origin of the Egyptian Temple*. Manchester, England: The Manchester University Press. 1969.

Ross, Daniel. *UFO's and the Complete Evidence from Space: The Truth about Venus, Mars, and the Moon*. Walnut Creek, California: Pintado Publishing. 1987. ISBN 0-944255-00-0.

Rux, Bruce. *Architects of the Underworld: Unriddling Atlantis, Anomalies of Mars, and the Mystery of the Sphinx*. Berkeley, California: Frog Ltd. 1996. ISBN 1-883319-46-3.

Sitchin, Zechariah. *The Wars of Gods and Men*, New York: Avon Books. 1985. ISBN 0-380-89585-

4.

Talbott, David, and Thornhill, Wallace. *Thunderbolts of the Gods: A Radical Reinterpretation of Human History and the Evolution of the Solar System*. Portland, Oregon: Mikamar Publishing 2005. ISBN 0- 9772851-0-3.

Tonnes, Mac. *After the Martian Apocalypse: Extraterrestrial Artifacts and the Case for Mars Exploration*. New York: Paraview Pocket Books. 2004. ISBN 0-7434-8293-X.

Van Flandern, Tom. *Dark Matter, Missing Planets, and New Comets: Paradoxes Resolved, Origins Illuminated*. Berkeley, California: North Atlantic Books. 1993. ISBN 1-55643-268-2.

Velikovsky, Immanuel. *Worlds in Collision*. New York: Dell Publishing Co. 1971. No ISBN number.

Whittaker, E. T. "On the partial differential equations of mathematical physics," *Mathematische Annalen*, Vol 57, 1903, pp. 333-355.

Wilson, Don. *Our Mysterious Spaceship Moon*.



NASA, NAZIS & JFK:

The Torbitt Document & the JFK Assassination

Introduction by Kenn Thomas

This book emphasizes the links between "Operation Paper Clip" Nazi scientists working for NASA, the assassination of JFK, and the secret Nevada air base Area 51. The Torbitt Document also talks about the roles played in the assassination by Division Five of the FBI, the Defense Industrial Security Command (DISC), the Las Vegas mob, and the shadow corporate entities Permindex and Centro-Mondiale Commerciale. The Torbitt Document claims that the same players planned the 1962 assassination attempt on Charles de Gaul, who ultimately pulled out of NATO because he traced the "Assassination Cabal" to Permindex in Switzerland and to NATO headquarters in Brussels. The Torbitt Document paints a dark picture of NASA, the military industrial complex, and the connections to Mercury, Nevada which headquarters the "secret space program."

258 PAGES, 5x8. PAPERBACK. ILLUSTRATED. \$16.00. CODE: NNJ



INSIDE THE GEMSTONE FILE

Howard Hughes, Onassis & JFK

by Kenn Thomas & David Hatcher Childress

Steamshovel Press editor Thomas takes on the Gemstone File in this run-up and run-down of the most famous underground document ever circulated. Photocopied and distributed for over 20 years, the Gemstone File is the story of Bruce Roberts, the inventor of the synthetic ruby widely used in laser technology today, and his relationship with the Howard Hughes Company and ultimately with Aristotle Onassis, the Mafia, and the CIA. Hughes kidnapped and held a drugged-up prisoner for 10 years; Onassis and his role in the Kennedy Assassination; how the Mafia ran corporate America in the 1960s; the death of Onassis son in the crash of a small private plane in Greece; Onassis as Ian Fleming's archvillain Ernst Stavro Blofeld; more.

320 PAGES, 6x9 PAPERBACK. ILLUSTRATED. \$16.00. CODE: IGF



POPULAR PARANOIA

The Best of Steamshovel Press

edited by Kenn Thomas

The anthology exposes the biological warfare origins of AIDS; the Nazi/Nation of Islam link; the cult of Elizabeth Clare Prophet; the Oklahoma City bombing writings of the late Jim Keith, as well as an article on Keith's own strange death; the conspiratorial mind of John Judge; Marion Pettie and the shadowy Finders group in Washington, DC; demonic iconography; the death of Princess Diana, its connection to the Octopus and the Saudi aerospace contracts; spies among the Rajneeshis; scholarship on the historic Illuminati; and many other parapolitical topics. The book also includes the Steamshovel's last-ever interviews with the great Beat writers Allen Ginsberg and William S. Burroughs, and neurosurgeon Timothy Leary, and new views of the master Beat, Neal Casady and Jack Kerouac's science fiction.

308 PAGES, 8x10 PAPERBACK. ILLUSTRATED. \$19.95. CODE: POPA



MIND CONTROL, OSWALD & JFK:

Were We Controlled?

Introduction by Kenn Thomas

Steamshovel Press editor Kenn Thomas examines the little-known book *Were We Controlled?*, first published in 1968. The book's author, the mysterious Lincoln Lawrence, maintained that Lee Harvey Oswald was a special agent who was a mind control subject, having received an implant in 1960 at a Russian hospital. Thomas examines the evidence for implant technology and the role it could have played in the Kennedy Assassination. Thomas also looks at the mind control aspects of the RFK assassination and details the history of implant technology. Looks at the case that the reporter Daron Raiten, Jr. was murdered because of this book.

256 PAGES, 6x9 PAPERBACK. ILLUSTRATED. NOTES. \$16.00. CODE: MCO



THE SHADOW GOVERNMENT

9-11 and State Terror

by Len Bracken, introduction by Kenn Thomas

Bracken presents the alarming yet convincing theory that nation-states engage in or allow terror to be visited upon their citizens. It is not just liberation movements and radical groups that deploy terrorist tactics for offensive ends. States use terror defensively to directly intimidate their citizens and to indirectly attack themselves or harm their citizens under a false flag. Their motives? To provide pretexts for war or for increased police powers or both. This stratagem of indirectly using terrorism has been executed by statesmen in various ways but tends to involve the pretense of blind eyes, misdirection, and coverups that give statesmen plausible deniability. Louisiana, Pearl Harbor, October Surprise, the first World Trade Center bombing, the Oklahoma City bombing and other well-known incidents suggest that terrorism is often and successfully used by states in an indirectly defensive way to take the offensive against enemies at home and abroad. Was 9-11 such an indirect defensive attack?

288 PAGES, 6x9 PAPERBACK. ILLUSTRATED. \$16.00. CODE: SGOV



LIQUID CONSPIRACY

JFK, LSD, the CIA, Area 51 & UFOs

by George Piccard

Underground author George Piccard on the politics of LSD, mind control, and Kennedy's involvement with Area 51 and UFOs. Reveals JFK's LSD experiences with Mary Pinchot Meyer. The plot thickens with an ever expanding web of CIA involvement, from underground buses with UFOs seen by JFK and Marilyn Monroe (among others) to a water conspiracy that affects every government agency from NASA to the Justice Department. This may have been the reason that Marilyn Monroe and actress-columnist Dorothy Kilgallen were both murdered. Focusing on the bizarre side of history, *Liquid Conspiracy* takes the reader on a psychedelic tour de force. This is your government on drugs!

264 PAGES, 6x9 PAPERBACK. ILLUSTRATED. \$14.95. CODE: LIQC



THE ARCH CONSPIRATOR

Essays and Actions

by **Len Bracken**

Veteran conspiracy author Len Bracken's witty essays and articles lead us down the dark corridors of conspiracy, politics, murder and mayhem. In 17 chapters Bracken takes us through a maze of interwoven tales from the Russian Conspiracy (and a few "extra notes" on conspiracies) to his interview with Costa Rican novelist Joaquin Gutierrez and his Psychogeographic Map into the Third Millennium. Other chapters in the book are: A General Theory of Civil War; A False Report Exposes the Dirty Truth About South African Intelligence Services; The New-Catline Conspiracy for the Cancellation of Debt; Anti-Labor Day; 1997 with selected Aphorisms Against Work; Solar Economics; and more. Bracken's work has appeared in such pop-conspiracy publications as *Paranoia*, *Sturm und Drang*, *Press* and the *Village Voice*. Len Bracken lives in Arlington, Virginia and haunts the back alleys of Washington D.C., keeping an eye on the predators who run our country. With a gun to his head, he cranks out his rants for fringe publications and in the editor of *Estraphale*, described by *New Yorker Magazine* as "fusion conspiracy theory."

256 PAGES, 6X9 PAPERBACK, ILLUSTRATED, BIBLIOGRAPHY, \$14.95, CODE: ACON.



PIRATES & THE LOST TEMPLAR FLEET

The Secret Naval War Between the Templars & the Vatican

by **David Hatcher Childress**

Childress takes us into the fascinating world of maverick sea captains who were Knights Templar (and later Scottish Rite Free Masons) who battled the Vatican, and the Spanish and Italian ships that sailed for the Pope. The lost Templar fleet was originally based at La Rochelle in southern France, but fled to the deep firths of Scotland upon the dissolution of the Order by King Phillip. This banned fleet of ships was later commanded by the St. Clair family of Roslyn Chapel (birthplace of Free Masonry). St. Clair and his Templars made a voyage to Canada in the year 1298 AD, nearly 100 years before Columbus! Later, this fleet of ships and new ones to come, flew the Skull and Crossbones, the symbol of the Knights Templar. They preyed on the ships of the Vatican coming from the rich ports of the Americas and went ultimately known as the Pirates of the Caribbean. Chapters include: 10,000 Years of Seafaring; The Knights Templar & the Crusades; The Templars and the Assassins; The Lost Templar Fleet and the Jolly Roger; Maps of the Ancient Sea Kings; Pirates, Templars and the New World; Christopher Columbus—Secret Templar Pirate?; Later Day Pirates and the War with the Vatican; Pirate Utopias and the New Jerusalem; more.

320 PAGES, 6X9 PAPERBACK, ILLUSTRATED, BIBLIOGRAPHY, \$16.95, CODE: PLTF



THE HISTORY OF THE KNIGHTS TEMPLARS

by **Charles G. Addison**, introduction by **David Hatcher Childress**

Chapters on the origin of the Templars, their popularity in Europe and their rivalry with the Knights of St. John, later to be known as the Knights of Malta. Detailed information on the activities of the Templars in the Holy Land, and the 1312 AD suppression of the Templars in France and other countries, which culminated in the execution of Jacques de Molay and the continuation of the Knights Templars in England and Scotland; the formation of the society of Knights Templars in London; and the rebuilding of the Temple in 1816. Plus a lengthy intro about the lost Templar fleet and its connections to the ancient North American sea routes.

395 PAGES, 6X9 PAPERBACK, ILLUSTRATED, \$16.95, CODE: HKT



THE LUCID VIEW

Investigations in Occultism, Ufology & Paranoid Awareness

by **Aeolus Kephas**

An unorthodox analysis of conspiracy theory, ufology, extraterrestrialism and occultism. *The Lucid View* takes us on an impartial journey through secret history, including the Gnostics and Templars; Crowley and Hitler's occult alliance; the sorcery wars of Freemasonry and the Illuminati; "Alternative Three" covert space colonization; the JFK assassination; the Manson murders; Jonestown and 9/11. Also delves into UFOs and alien abductions, their relations to mind control technology and sorcery practices, with reference to inorganic beings and Kundalini energy. The book offers a balanced overview on religious, magical and paranoid beliefs pertaining to the 21st century, and their social, psychological, and spiritual implications for humanity, the leading game player in the grand mythic drama of Armageddon.

298 PAGES, 6X9 PAPERBACK, ILLUSTRATED, \$16.95, CODE: LVEW



MIND CONTROL, WORLD CONTROL

by **Jim Keith**

Veteran author and investigator Jim Keith uncovers a surprising amount of information on the technology, experimentation and implementation of mind control. Various chapters in this shocking book are on early CIA experiments such as Project Artichoke and Project R.H.I.C.-EDOM, the methodology and technology of implants, mind control assassins and couriers, various famous Mind Control victims such as Sirhan Sirhan and Candy Jones. Also featured in this book are chapters on how mind control technology may be linked to some UFO activity and "UFO abductions."

256 PAGES, 6X9 PAPERBACK, ILLUSTRATED, FOOTNOTES, \$14.95, CODE: MCWC



MASS CONTROL

Engineering Human Consciousness

by **Jim Keith**

Conspiracy expert Keith's final book on mind control, Project Monarch, and mass manipulation presents chilling evidence that we are indeed spinning a Matrix. Keith describes the New Man, where conception of reality is a dance of electronic images fired into his forebrain, a possumer construction of his masters, designed so that he will not—under any circumstances—perceive the actual. His happiness is delivered to him through a tube or an electronic connection. His God lurks behind an electronic curtain, when the curtain is pulled away we find the CIA sorcerer, the media manipulator! Chapters on the CIA, Tavistock, Jolly West and the Violence Center, Guerrilla Mindwar, Bozo Taylor, other recent "victims," more.

256 PAGES, 6X9 PAPERBACK, ILLUSTRATED, INDEX, \$16.95, CODE: MASC



PERPETUAL MOTION

The History of an Obsession

by Arthur W. J. G. Ord-Hume

Make a machine which gives out more work than the energy you put into it, and you have perpetual motion. The deceptively simple task of making a mechanism which would turn forever fascinated many an inventor, and a number of famous men and physicists applied themselves to the task. Despite the naivety and blatant trickery of many of the inventors, there are a handful of mechanisms which defy explanation. A vast canvas-covered wheel which turned by itself was erected in the Tower of London. Another wheel, equally surrounded by mystery and intrigue, turned endlessly in Germany. Chapters include: Elementary Physics and Perpetual Motion; Medieval Perpetual Motion; Self-moving Wheels and Overbalancing Weights; Lodestones, Elects Magnetism and Steam; Capillary Attraction and Springswheels; Cox's Perpetual Motion; Keely and his Amazing Motor; Odd Ideas about Vaporization and Liquefaction; The Astonishing Case of the Garbold Project; Ever-Ringing Bells and Radium Perpetual Motion; Perpetual Motion Inventors Barred from the US Patent Office; Rolling Ball Clocks; Perpetual Lamps; The Perpetuity of the Perpetual Motion Inventor; more.

260 PAGES, 6X9 PAPERBACK, ILLUSTRATED, BIBLIOGRAPHY, INDEX, \$20.00. CODE: PPM



HIDDEN NATURE

The Startling Insights of Viktor Schauberger

by Alick Bartholomew, foreword by David Bellamy

Viktor Schauberger (1885-1958) pioneered a new understanding of the Science of Nature, (re)discovering its primary laws and principles, unacknowledged by contemporary science. From studying the fast flowing streams of the unspoilt Alps, he gained insights into water as a living organism. He showed that water is like a magnetic tape; it can carry information that may either enhance or degrade the quality of organisms. Our failure to understand the need to protect the quality of water is the principle cause of environmental degradation on the planet. Schauberger warned of climatic chaos resulting from deforestation and called for work with free energy machines and energy generation. Chapters include: Schauberger's Vision; Different Kinds of Energy; Attraction & Repulsion of Opposites; Nature's Patterns & Shapes; Energy Production; Motion, Key to Balance; Atmosphere/Electricity; The Nature of Water; Hydrological Cycle; Formation of Springs; How Rivers Flow; Supplying Water; The Role of the Forest; Tree Metabolism; Soil Fertility and Cultivation; Organic Cultivation; The Energy Revolution; Harnessing Implosion Power; Viktor Schauberger & Society; more.

288 PAGES, 7X10 PAPERBACK, ILLUSTRATED, REFERENCES, INDEX, \$22.95. CODE: HNAT



MIND CONTROL AND UFOs

Casebook on Alternative 3

by Jim Keith

Drawing on his diverse research and a wide variety of sources, Jim Keith delves into the bizarre story behind *Alternative 3*, including mind control programs, underground bases not only on the Earth but also on the Moon and Mars, the real origin of the UFO problem, the mysterious deaths of Marconi Electronics employees in Britain during the 1980s, top scientists around the world kidnapped to work at the secret government space bases, the Russian-American superpower arms race of the 50s, 60s and 70s as a massive hoax, and other startling areas. Chapters include: Secret Societies and *The Newswatch*; The Fourth Reich; UFOs and the Space Program; Government UFOs; Hot Jobs and Crop Circles; Missing Scientists and LGIBs; Ice Picks, Electrodes and LSD; Electronic Wars; Batch Crossings; The Depopulation Beach; Veins and Tributaries; Lunar Base Alpha One; Dnirofo; Other Alternatives; Noah's Ark II; *Das Maraprojekt*; more.

248 PAGES, 6X9 PAPERBACK, ILLUSTRATED, BIBLIOGRAPHY, \$14.95. CODE: MCUE



UFOs, PSI AND SPIRITUAL EVOLUTION

A Journey through the Evolution of Interstellar Travel

by Christopher Humphries, Ph.D.

The modern era of UFOs began in May, 1947, one year and eight months after Hiroshima. This is no coincidence, and suggests there are beings in the universe with the ability to jump hundreds of light years in an instant. That is teleportation, a power of the mind. If it weren't for levitation and teleportation, star travel would not be possible at all, since physics rules out star travel by technology. So if we want to go to the stars, it is the mind and spirit we must study, not technology. The mind must be a dark matter object, since it is invisible and intangible and can freely pass through solid objects. A disembodied mind can see the de Broglie vibrations (the basis of quantum mechanics) radiated by both dark and ordinary matter during near-death or out-of-body experiences. Levitation requires warping the geodesics of space-time. The latest theory in physics is String Theory, which requires six extra spatial dimensions. The mind warps those higher geodesics to produce teleportation. We are a primitive and violent species. Our universes lack any scenarios of mind, spirit or civilization. If we want to go to the stars, the first thing we must do is "grow up." That is the real Journey.

274 PAGES, 6X9 PAPERBACK, ILLUSTRATED, REFERENCES, \$16.95. CODE: UPSE



INVISIBLE RESIDENTS

The Reality of Underwater UFOs

by Ivan T. Sanderson, Foreword by David Hatcher Childress

This book is a groundbreaking contribution to the study of the UFO enigma, originally published over 30 years ago. In this book, Sanderson, a renowned zoologist with a keen interest in the paranormal, puts forward the curious theory that "OINTS"—Other Intelligences—live under the Earth's oceans. This underwater, parallel, civilization may be twice as old as *Homo sapiens*, he proposes, and may have "developed what we call space flight." Sanderson postulates that the OINTS are behind many UFO sightings as well as the mysterious disappearances of aircraft and ships in the Bermuda Triangle. What better place to have an impenetrable base than deep within the oceans of the planet? Yet, if UFOs, or at least some of them, are coming from beneath our oceans or lakes, does it necessarily mean that there is another civilization besides our own that is responsible? In fact, could it be that since WWII a number of underwater UFO bases have been constructed by the very human governments of our planet? Whatever their source, Sanderson offers here an exhaustive study of USOs (Unidentified Submarine Objects) observed in nearly every part of the world. He presents many well-documented and exciting case studies of these unusual sightings; more.

298 PAGES, 6X9 PAPERBACK, ILLUSTRATED, BIBLIOGRAPHY, INDEX, \$16.95. CODE: INVS

THE WORLD CATAclysm IN 2012

Maya Calendar Countdown

by Patrick Geryl

In his previous book, *The Orion Prophecy*, author Geryl theorized that the lost civilization of Atlantis was destroyed by a huge cataclysm engendered by changes in sunspot activity affecting Earth's magnetic poles and atmosphere. Having experienced earlier catastrophes, the Atlanteans had developed amazing astronomical and mathematical knowledge that enabled them to predict the date of their continent's demise. They devised a survival plan, and were able to pass along their knowledge to civilizations we know as the Maya and Old Egyptians. Here, Geryl shows that the mathematics and astronomy of the ancient Egyptians and Maya are related, and have similar predictive power which should be taken very seriously. He cracks their hidden codes that show definitively that the next earth-consuming cataclysm will occur in 2012, and calls urgently for the excavation of the Labyrinth of ancient Egypt, a storehouse of Atlantean knowledge which is linked in prophecy to the May predictions.

256 PAGES, 6x9 PAPERBACK, ILLUSTRATED, REFERENCES, \$16.95, CODE: WC20



HAARP

The Ultimate Weapon of the Conspiracy

by Jerry Smith

The HAARP project in Alaska is one of the most controversial projects ever undertaken by the U.S. Government. Jerry Smith gives us the history of the HAARP project and explains how it works, in technically correct yet easy to understand language. At best, HAARP is science out of control; at worst, HAARP could be the most dangerous device ever created, a futuristic technology that is everything from super-beam weapon to world-wide mind control device. Topics include Over-the-Horizon Radar and HAARP; Mind Control, ELF and HAARP; The Tesla Connection; The Russian Woodpecker; GWEN & HAARP; Earth Penetrating Tomography; Weather Modification; Secret Science of the Conspiracy; more. Includes the complete 1987 Eastland patent for his pulsed super-weapon that he claims was stolen by the HAARP Project.

256 PAGES, 6x9 PAPERBACK, ILLUSTRATED, \$14.95, CODE: HARP

SECRETS OF THE HOLY LANCE

The Spear of Destiny in History & Legend

by Jerry E. Smith and George Piccard

As Jesus Christ hung on the cross a Roman centurion placed the Savior's side with his spear. A legend has arisen that "whoever possesses this Holy Lance and understands the powers it serves, holds in his hand the destiny of the world for good or evil." *Secrets of the Holy Lance* traces the Spear from its possession by Constantine, Rome's first Christian Caesar, to Charlemagne's claim that with it he ruled the Holy Roman Empire by Divine Right, and on through two thousand years of kings and emperors, until it came within Hitler's grasp—and beyond! Did it rest for a while in Antarctic ice? Is it now hidden in Europe, awaiting the next person to claim its awesome power? Neither debunking nor worshiping, *Secrets of the Holy Lance* seeks to pierce the veil of myth and mystery around the Spear. More belief that it was infused with magic by virtue of its shedding the Savior's blood has made men kings. But what if it's more? What are "the powers it serves"?

312 PAGES, 6x9 PAPERBACK, ILLUSTRATED, BIBLIOGRAPHY, \$16.95, CODE: SOHL



FROM LIGHT INTO DARKNESS

The Evolution of Religion in Ancient Egypt

by Stephen S. Mehler

Building on the esoteric information first revealed in *Land of Osiris*, this exciting book presents more of Abd'El Hakim's oral traditions, with radical new interpretations of how religion evolved in prehistoric and dynastic Kemet, or Egypt. * Have popular modern religions developed out of practices in ancient Egypt? * Did religion in Egypt represent only a shadow of the spiritual practices of prehistoric people? * Have the Western Mystery Schools such as the Rosicrucian Order evolved from these ancient systems? * Author Mehler explores the teachings of the King Akhenaten and the real Moses, the true identity of the Hyksos, and Akhenaten's connections to The Exodus, Judaism and the Rosicrucian Order. Here for the first time in the West, are the spiritual teachings of the ancient Kemetians, the foundation for the coming new cycle of consciousness—The Awakening; more.

240 PAGES, 6x9 PAPERBACK, ILLUSTRATED, REFERENCES, \$16.95, CODE: FLID



THE LAND OF OSIRIS

An Introduction to Khemitology

by Stephen S. Mehler

Was there an advanced prehistoric civilization in ancient Egypt who built the great pyramids and carved the Great Sphinx? Did the pyramids serve as energy devices and not as tombs for kings? Mehler has uncovered an indigenous oral tradition that still exists in Egypt, and has been fortunate to have studied with a living master of this tradition, Abd'El Hakim Awyan. Mehler has also been given permission to present these teachings to the Western world, teachings that unfold a whole new understanding of ancient Egypt. Chapters include: Egyptology and Its Paradigm; Aswat Nefer—The Harmony of Water, Kemet and the Myth of Atlantis; The Extraterrestrial Question; more.

272 PAGES, 6x9 PAPERBACK, ILLUSTRATED, COLOR SECTION, BIBLIOGRAPHY, \$18.95, CODE: LOOS





ORACLE OF THE ILLUMINATI Coincidence, Cocreation, Contact

By William Henry

Investigative mythologist William Henry follows up his best-selling *Cloak of the Illuminati* with this illustration-packed treatise on the secret codes, oracles and technology of ancient Illuminati. His primary expertise and mission is finding and interpreting ancient gateway stories which feature advanced technology for raising of spiritual vibration and increasing our body's innate healing ability. Chapters include: From Cloak to Oracle; The Return of Sophia; The Cosmic G-Spot Simulator; The Reality of the Rulers; The Hymn of the Pearl; The Realm of the Illuminati; Francis Bacon's Oracle; Abydos and the Head of Sophia; Enki and the Flower of Light; The God Head and the Dodecahedron; The Star Walker; The Big Secret; more.

243 PAGES, 6x9 PAPERBACK, ILLUSTRATED, NOTES & REFERENCES, \$16.95, CODE: ORIL



CLOAK OF THE ILLUMINATI

Secrets, Transformations, Crossing the Star Gate
by William Henry

Thousands of years ago the stargate technology of the gods was lost. Mayan Prophecy says it will return by 2012, along with our alignment with the center of our galaxy. In this book: Find examples of stargates and wormholes in the ancient world; Examine myths and scripture with hidden references to a stargate cloak worn by the Illuminati, including Mari, Nimrod, Elijah, and Jesus; See rare images of gods and goddesses wearing the Cloak of the Illuminati; Learn about Saddam Hussein and the secret missing library of Jesus; Uncovers the secret Roman-era eugenics experiments at the Temple of Hathor in Denderah, Egypt; Explore the duplicate of the Stargate Pillar of the Gods in the Illuminati's secret garden in Nashville, TN; Discover the secrets of manna, the food of the angels; Share the lost Peace Prayer posture of Osiris, Jesus and the Illuminati; more. Chapters include: Seven Stars Under Three Stars; The Long Walk; Squaring the Circle; The Mill of the Host; The Miracle Garment; The Fig; Nimrod: The Mighty Man; Nebuchadnezzar's Gate; The New Mighty Man; more.

238 PAGES, 6x9 PAPERBACK, ILLUSTRATED, BIBLIOGRAPHY, INDEX, \$16.95, CODE: COIL



THE GIZA DEATH STAR

The Paleophysics of the Great Pyramid & the Military Complex at Giza

by Joseph P. Farrell

Was the Giza complex part of a military installation over 10,000 years ago? Chapters include: An Archaeology of Mass Destruction; Truth and Theories; The Machine Hypothesis; Pythagoras, Plato, Plank, and the Pyramid; The Weapon Hypothesis; Encoded Harmonics of the Plank Units in the Great Pyramid; High Frequency Direct Current "Impulse" Technology; The Grand Gallery and its Crystals; Gravitational Resonators; The Other Two Large Pyramids; "Caisseways," and the "Temples"; A Pulse Conjugate Hypothesis; Evidence of the Use of Weapons of Mass Destruction in Ancient Times; more.

290 PAGES, 6x9 PAPERBACK, ILLUSTRATED, \$16.95, CODE: GDS



THE GIZA DEATH STAR DEPLOYED

The Physics & Engineering of the Great Pyramid

by Joseph P. Farrell

Farrell expands on his thesis that the Great Pyramid was a chemical laser, designed as a weapon and eventually deployed—with disastrous results to the solar system. Includes: Exploding Planets, The Movie, the Mirror, and the Model; Dating the Catastrophe; and the Cosmopolis; A Brief History of the Esoteric and Exoteric Investigations of the Great Pyramid; No Machines, Please!; The Stargate Conspiracy; The Scalar Weapon; Message or Machine?; A Tesla Analysis of the Putative Physics and Engineering of the Giza Death Star; Cohering the Zero Point, Vacuum Energy, Flux; Synopsis of Scalar Physics and Paleophysics; Configuring the Scalar Pulse Wave; Inferred Applications in the Great Pyramid; Quantum Numerology; Feedback Loops and Tetrahedral Physics; and more.

290 PAGES, 6x9 PAPERBACK, ILLUSTRATED, BIBLIOGRAPHY, INDEX, \$16.95, CODE: GDSD



THE GIZA DEATH STAR DESTROYED

The Ancient War For Future Science

by Joseph P. Farrell

This is the third and final volume in the popular *Giza Death Star* series, physicist Farrell looks at what eventually happened to the 10,000-year-old Giza Death Star after it was deployed—it was destroyed by an internal explosion. Recapping his earlier books, Farrell moves on to events of the final days of the Giza Death Star and its awesome power. These final events, eventually leading up to the destruction of this giant machine, are dissected one by one, leading us to the eventual abandonment of the Giza Military Complex—an event that halted civilization back into the Stone Age. Chapters include: The Mars-Earth Connector; The Lost "Root Races" and the Moral Reason for the Flood; The Destruction of Krypton; The Electrodynamic Solar System; Exploding Planets and Ancient Wars; Turning the Stream of the Flood; the Origin of Secret Societies and Esoteric Traditions; The Quest to Recover Ancient Mega-Technology; Non-Equilibrium Paleophysics; Monatomic Paleophysics; Frequencies, Vertices and Mass Particles; the Pyramid Power of Dr. Pat Flanagan and Joe Parr; The Topology of the Aether; A Final Physical Effect: "Acoustic" Intensity of Fields; The Pyramid of Crystals; tons more.

292 PAGES, 6x9 PAPERBACK, ILLUSTRATED, BIBLIOGRAPHY, \$16.95, CODE: GDES

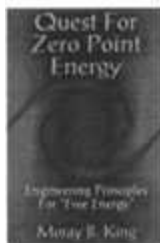

QUEST FOR ZERO-POINT ENERGY Engineering Principles for "Free Energy"

by Moray B. King

King expands, with diagrams, on how free energy and anti-gravity are possible. The theories of zero point energy maintain there are tremendous fluctuations of electrical field energy embedded within the fabric of space. King explains the following topics: Tapping the Zero-Point Energy as an Energy Source; Fundamentals of a Zero-Point Energy Technology; Vacuum Energy Vortices; The Super Tube; Charge Clusters: The Basis of Zero-Point Energy Inventions; Vortex Filaments, Torsion Fields and the Zero-Point Energy; Transforming the Planet with a Zero-Point Energy Experiment; Dual Vortex Forms: The Key to a Large Zero-Point Energy Coherence. Packed with diagrams, patents and photos. With power shortages now a daily reality in many parts of the world, this book offers a fresh approach very rarely mentioned in the mainstream media.

224 PAGES, 6X9 PAPERBACK, ILLUSTRATED, \$14.95. CODE: QZPE

TAPPING THE ZERO POINT ENERGY

Free Energy & Anti-Gravity in Today's Physics

by Moray B. King

King explains how free energy and anti-gravity are possible. The theories of the zero point energy maintain there are tremendous fluctuations of electrical field energy imbedded within the fabric of space. This book tells how, in the 1930s, inventor T. Henry Moray could produce a fifty kilowatt "free energy" machine; how an electrified plasma vortex creates anti-gravity; how the Pons/Fleischmann "cold fusion" experiment could produce tremendous heat without fusion; and how certain experiments might produce a gravitational anomaly.

180 PAGES, 5X8 PAPERBACK, ILLUSTRATED, \$12.95. CODE: TAP

THE FREE-ENERGY DEVICE HANDBOOK

A Compilation of Patents and Reports

by David Hatcher Childress

A large-format compilation of various patents, papers, descriptions and diagrams concerning free-energy devices and systems. *The Free-Energy Device Handbook* is a visual tool for experimenters and researchers into magnetic motors and other "over-unity" devices. With chapters on the Adams Motor, the Hans Coler Generator, cold fusion, superconductors, "N" machines, space-energy generators, Nikola Tesla, T. Townsend Brown, and the latest in free-energy devices. Packed with photos, technical diagrams, patents and fascinating information, this book belongs on every science shelf. With energy and profit being a major political reason for fighting various wars, free-energy devices, if ever allowed to be mass distributed to consumers, could change the world! Get your copy now before the Department of Energy bans this book!

292 PAGES, 8X10 PAPERBACK, ILLUSTRATED, BIBLIOGRAPHY, \$16.95. CODE: FEH

ETHER TECHNOLOGY

A Rational Approach to Gravity Control

by Rho Sigma

This classic book on anti-gravity and free energy is back in print and back in stock. Written by a well-known American scientist under the pseudonym of "Rho Sigma," this book delves into international efforts at gravity control and discuss craft propulsion. Before the Quantum Field, there was "Ether." This small, but informative book has chapters on John Searle and "Searle discs," T. Townsend Brown and his work on anti-gravity and other-vortex turbines. Includes a foreword by former NASA astronaut Edgar Mitchell.

108 PAGES, 6X9 PAPERBACK, ILLUSTRATED, \$12.95. CODE: ETT



THE TIME TRAVEL HANDBOOK

A Manual of Practical Teleportation & Time Travel

edited by David Hatcher Childress

In the tradition of *The Anti-Gravity Handbook* and *The Free-Energy Device Handbook*, science and UFO author David Hatcher Childress takes us into the weird world of time travel and teleportation. Not just a whacked-out look at science fiction, this book is an authoritative chronicle of real-life time travel experiments, teleportation devices and more. *The Time Travel Handbook* takes the reader beyond the government experiments and deep into the uncharted territory of early time travellers such as Nikola Tesla and Guglielmo Marconi and their alleged time travel experiments, as well as the Wilson Brothers of EMI and their connection to the Philadelphia Experiment—the U.S. Navy's foray into invisibility, time travel, and teleportation. Childress looks into the claims of time travelling individuals, and investigates the unusual claim that the pyramids on Mars were built in the future and sent back in time. A highly visual, large-format book, with patents, photos and schematics. Be the first on your block to build your own time travel device!

316 PAGES, 7X10 PAPERBACK, ILLUSTRATED, \$16.95. CODE: TTH



MAN-MADE UFOS 1944—1994

Fifty Years of Suppression

by Renato Vesco & David Hatcher Childress

A comprehensive look at the early "flying saucer" technology of Nazi Germany and the genesis of man-made UFOS. This book takes us from the work of captured German scientists to escaped battalions of Germans, secret communities in South America and Antarctica to today's state-of-the-art "Dramaland" flying machines. Heavily illustrated, this astonishing book blows the lid off the "government UFO conspiracy" and explains with technical diagrams the technology involved. Examined in detail are secret underground airfields and factories; German secret weapons; "suction" aircraft; the origin of NASA; gyroscopic stabilizers and engines; the secret Marconi aircraft factory in South America; and more. Introduction by W.A. Hartman, author of the Dell novels *GENESIS* and *REVELATION*.

318 PAGES, 6X9 PAPERBACK, ILLUSTRATED, INDEX & FOOTNOTES, \$18.95. CODE: MMU



THE A.T. FACTOR

A Scientists Encounter with UFOs: Piece For A Jigsaw Part 3

by Leonard Cramp

British aerospace engineer Cramp began much of the scientific anti-gravity and UFO propulsion analysis back in 1955 with his landmark book *Space, Gravity & the Flying Saucer* (out-of-print and rare). His next books (available from Adventures Unlimited) *UFOs & Anti-Gravity: Piece for a Jig-Saw* and *The Cosmic Matrix: Piece for a Jig-Saw Part 2* began Cramp's in depth look into gravity control, free-energy, and the interlocking web of energy that pervades the universe. In this final book, Cramp brings to a close his detailed and controversial study of UFOs and Anti-Gravity. **324 PAGES. 6X9 PAPERBACK. ILLUSTRATED. BIBLIOGRAPHY. INDEX. \$16.95. CODE: ATF**

COSMIC MATRIX

Piece for a Jig-Saw, Part Two

by Leonard G. Cramp

Leonard G. Cramp, a British aerospace engineer, wrote his first book *Space Gravity and the Flying Saucer* in 1954. *Cosmic Matrix* is the long-awaited sequel to his 1966 book *UFOs & Anti-Gravity: Piece for a Jig-Saw*. Cramp has had a long history of examining UFO phenomena and has concluded that UFOs use the highest possible aeronautic science to move in the way they do. Cramp examines anti-gravity effects and theorizes that this super-science used by the craft—described in detail in the book—can lift mankind into a new level of technology, transportation and understanding of the universe. The book takes a close look at gravity control, time travel, and the interlocking web of energy between all planets in our solar system with Leonard's unique technical diagrams. A fantastic voyage into the present and future! **364 PAGES. 6X9 PAPERBACK. ILLUSTRATED. BIBLIOGRAPHY. \$16.00. CODE: CMX**

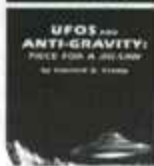

UFOs AND ANTI-GRAVITY

Piece For A Jig-Saw

by Leonard G. Cramp

Leonard G. Cramp's 1966 classic book on flying saucer propulsion and suppressed technology is a highly technical look at the UFO phenomena by a trained scientist. Cramp first introduces the idea of "anti-gravity" and introduces us to the various theories of gravitation. He then examines the technology necessary to build a flying saucer and examines in great detail the technical aspects of such a craft. Cramp's book is a wealth of material and diagrams on flying saucers, anti-gravity, suppressed technology, G fields and UFOs. Chapters include *Crossroads of Aerodynamics, Aerodynamic Saucers, Limitations of Rocketry, Gravitation and the Ether, Gravitational Spaceships, G-Field Lift Effects, The Bi-Field Theory, VTOL and Hovercraft, Analysis of UFO photos, more.* **388 PAGES. 6X9 PAPERBACK. ILLUSTRATED. \$16.95. CODE: UAG**

THE TESLA PAPERS

Nikola Tesla on Free Energy & Wireless Transmission of Power

by Nikola Tesla, edited by David Hatcher Childress

David Hatcher Childress takes us into the incredible world of Nikola Tesla and his amazing inventions. Tesla's rare article "The Problem of Increasing Human Energy with Special Reference to the Harnessing of the Sun's Energy" is included. This lengthy article was originally published in the June, 1900 issue of *The Century Illustrated Monthly Magazine* and it was the outline for Tesla's master blueprint for the world. Tesla's fantastic vision of the future, including wireless power, anti-gravity, free energy and highly advanced solar power. Also included are some of the papers, patents and material collected on Tesla at the Colorado Springs Tesla Symposiums, including papers on: "The Secret History of Wireless Transmission" "Tesla and the Magnifying Transmitter" "Design and Construction of a Half-Wave Tesla Coil" "Electrostatics: A Key to Free Energy" "Progress in Zero-Point Energy Research" "Electromagnetic Energy from Antennas to Atoms" "Tesla's Particle Beam Technology" "Fundamental Excitatory Modes of the Earth-Ionosphere Cavity" **325 PAGES. 8X10 PAPERBACK. ILLUSTRATED. \$16.95. CODE: TTP**

THE FANTASTIC INVENTIONS OF NIKOLA TESLA

by Nikola Tesla with additional material by David Hatcher Childress

This book is a readable compendium of patents, diagrams, photos and explanations of the many incredible inventions of the originator of the modern era of electrification. In Tesla's own words are such topics as wireless transmission of power, death rays, and radio-controlled airships. In addition, rare material on German bases in Antarctica and South America, and a secret city built at a remote jungle site in South America by one of Tesla's students, Guglielmo Marconi. Marconi's secret group claims to have built flying saucers in the 1940s and to have gone to Mars in the early 1950s! Incredible photos of these Tesla craft are included. The Ancient Atlantean system of broadcasting energy through a grid system of obelisks and pyramids is discussed, and a fascinating concept comes out of one chapter: that Egyptian engineers had to wear protective metal head-shields while in these power plants, hence the Egyptian Pharaoh's head covering as well as the Face on Mars! "His plan to transmit free electricity into the atmosphere." "How electrical devices would work using only small antennas." "Why unlimited power could be utilized anywhere on earth." "How radio and radar technology can be used as death-ray weapons in Star Wars." **342 PAGES. 6X9 PAPERBACK. ILLUSTRATED. \$16.95. CODE: FINT**





REICH OF THE BLACK SUN
Nazi Secret Weapons and the Cold War Allied Legend
 by Joseph P. Farrell

Why were the Allies worried about an atom bomb attack by the Germans in 1944? Why did the Soviets threaten to use poison gas against the Germans? Why did Hitler in 1945 insist that holding Prague could win the war for the Third Reich? Why did US General George Patton's Third Army race for the Skoda works at Pilsen in Czechoslovakia instead of Berlin? Why did the US Army not test the uranium atom bomb it dropped on Hiroshima? Why did the Luftwaffe fly a non-stop round trip mission to within twenty miles of New York City in 1944? *Reich of the Black Sun* takes the reader on a scientific-historical journey in order to answer these questions. Arguing that Nazi Germany actually won the race for the atom bomb in late 1944, and then goes on to explore the even more secretive research the Nazis were conducting into the occult, alternative physics and new energy sources.

352 PAGES, 6x9 PAPERBACK, ILLUSTRATED, BIBLIOGRAPHY, \$16.95, CODE: ROBS



SAUCERS OF THE ILLUMINATI
 by Jim Keith, Foreword by Kenn Thomas

Soaking the truth behind stories of alien invasion, secret underground bases, and the secret plans of the New World Order, *Saucers of the Illuminati* offers ground breaking research, uncovering clues to the nature of UFOs and to forces even more sinister: the secret cabal behind planetary control! Includes mind control, saucer abductions, the MJ-12 documents, cattle mutilations, government anti-gravity testing, the Sirius Connection, science fiction author Philip K. Dick and his efforts to expose the Illuminati, plus more from veteran conspiracy and UFO author Keith. Conspiracy expert Keith's final book on UFOs and the highly secret group that manufactures them and uses them for their own purposes: the control and manipulation of the population of planet Earth.

148 PAGES, 6x9 PAPERBACK, ILLUSTRATED, \$12.95, CODE: SOIL

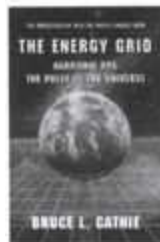

THE ENERGY MACHINE OF T. HENRY MORAY
 by Moray B. King

In the 1920s T. Henry Moray invented a "free energy" device that reportedly output 50 kilowatts of electricity. It could not be explained by standard science at that time. The electricity exhibited a strange "cold current" characteristic: where thin wires could conduct appreciable power without heating. Moray suffered ruthless suppression, and in 1939 the device was destroyed. Frontier science lecturer and author Moray B. King explains the invention with today's science. Modern physics recognizes that the vacuum contains tremendous energy called the zero-point energy. A way to coherently activate it appears surprisingly simple: first create a glow plasma or corona, then abruptly pulse it. Other inventors have discovered this approach (sometimes unwittingly) to create novel energy devices, and they too were suppressed. The common pattern of their technologies clarified the fundamental operating principle. King hopes to inspire engineers and inventors so that a new energy source can become available to mankind.

192 PAGES, 6x8 PAPERBACK, ILLUSTRATED, \$14.95, CODE: EMHM



THE ENERGY GRID
 Harmonic 695, The Pulse of the Universe
 by Captain Bruce Cathie.

This is the breakthrough book that explores the incredible potential of the Energy Grid and the Earth's Unified Field all around us. Cathie's first book, *Harmonic 53*, was published in 1968 when he was a commercial pilot in New Zealand. Since then, Captain Bruce Cathie has been the premier investigator into the amazing potential of the infinite energy that surrounds our planet every microsecond. Cathie investigates the Harmonics of Light and how the Energy Grid is created. In this amazing book are chapters on UFO Propulsion, Nikola Tesla, Unified Equations, the Mysterious Aerials, Pyramids & the Grid, Nuclear Detonation and the Grid, Maps of the Ancients, an Australian Stonehenge examined, more.

255 PAGES, 6x9 TRADEPAPER, ILLUSTRATED, \$15.95, CODE: TEG



THE BRIDGE TO INFINITY
 Harmonic 371244
 by Captain Bruce Cathie

Cathie has popularized the concept that the earth is crisscrossed by an electromagnetic grid system that can be used for anti-gravity, free energy, levitation and more. The book includes a new analysis of the harmonic nature of reality, acoustic levitation, pyramid power, harmonic receiver towers and UFO propulsion. It concludes that today's scientists have at their command a fantastic store of knowledge with which to advance the welfare of the human race.

204 PAGES, 6x9 TRADEPAPER, ILLUSTRATED, \$14.95, CODE: BTF



THE HARMONIC CONQUEST OF SPACE
 by Captain Bruce Cathie

Chapters include: Mathematics of the World Grid; the Harmonics of Hiroshima and Nagasaki; Harmonic Transmission and Receiving; the Link Between Human Brain Waves; the Cavity Resonance between the Earth; the Ionosphere and Gravity; Edgar Cayce—the Harmonics of the Subconscious; Stonehenge; the Harmonics of the Moon; the Pyramids of Mars; Nikola Tesla's Electric Car; the Robert Adams Pulsed Electric Motor Generator; Harmonic Clues to the Unified Field; and more. Also included are tables showing the harmonic relations between the earth's magnetic field, the speed of light, and anti-gravity/gravity acceleration at different points on the earth's surface. New chapters in this edition on the giant stone spheres of Costa Rica, Atomic Tests and Volcanic Activity, and a chapter on Ayers Rock analyzed with Stone Mountain, Georgia.

248 PAGES, 6x9, PAPERBACK, ILLUSTRATED, BIBLIOGRAPHY, \$16.95, CODE: HCS



THE ANTI-GRAVITY HANDBOOK

edited by David Hatcher Childress, with Nikola Tesla, T.B. Paulicki, Bruce Cathie, Albert Einstein and others

The new expanded compilation of material on Anti-Gravity, Free Energy, Flying Saucer Propulsion, UFOs, Suppressed Technology, NASA Cover-ups and more. Highly illustrated with patents, technical illustrations and photos. This revised and expanded edition has more material, including photos of Area 51, Nevada, the government's secret testing facility. This classic on weird science is back in a 90s format!

- How to build a flying saucer.
- Arthur C. Clarke on Anti-Gravity.
- Crystals and their role in levitation.
- Secret government research and development.
- Nikola Tesla on how anti-gravity airships could draw power from the atmosphere.
- Bruce Cathie's Anti-Gravity Equation.
- NASA, the Moon and Anti-Gravity.

230 PAGES. 7X10 PAPERBACK. ILLUSTRATED. \$14.95. CODE: AGH



ANTI-GRAVITY & THE WORLD GRID

Is the earth surrounded by an intricate electromagnetic grid network offering free energy? This compilation of material on ley lines and world power points contains chapters on the geography, mathematics, and light harmonics of the earth grid. Learn the purpose of ley lines and ancient megalithic structures located on the grid. Discover how the grid made the Philadelphia Experiment possible. Explore the Coral Castle and many other mysteries, including acoustic levitation, Tesla Shields and scalar wave weaponry. Browse through the section on anti-gravity patents, and research resources.

274 PAGES. 7X10 PAPERBACK. ILLUSTRATED. \$14.95. CODE: AGW



ANTI-GRAVITY & THE UNIFIED FIELD

edited by David Hatcher Childress

Is Einstein's Unified Field Theory the answer to all of our energy problems? Explored in this compilation of material is how gravity, electricity and magnetism manifest from a unified field around us. Why artificial gravity is possible; secrets of UFO propulsion; free energy; Nikola Tesla and anti-gravity airships of the 20s and 30s; flying saucers as superconducting whorls of plasma; anti-mass generators; vortex propulsion; suppressed technology; government cover-ups; gravitational pulse drive; spacecraft & more.

240 PAGES. 7X10 PAPERBACK. ILLUSTRATED. \$14.95. CODE: AGU



THE GIZA DEATH STAR

The Paleophysics of the Great Pyramid & the Military Complex at Giza

by Joseph P. Farrell

Physicist Joseph Farrell's amazing book on the secrets of Great Pyramid of Giza. *The Giza Death Star* starts where British engineer Christopher Dunn leaves off in his 1998 book, *The Giza Power Plant*. Was the Giza complex part of a military installation over 10,000 years ago? Chapters include: An Archaeology of Mass Destruction, Thoht and Theories; The Machine Hypothesis; Pythagoras, Plato, Planck, and the Pyramid; The Weapon Hypothesis; Encoded Harmonics of the Planck Units in the Great Pyramid; High Frequency Direct Current "Impulse" Technology; The Grand Gallery and its Crystalline Gravitational Resonators; The Other Two Large Pyramids; the "Causeways," and the "Temples"; A Phase Conjugate Howitzer; Evidence of the Use of Weapons of Mass Destruction in Ancient Times; more.

290 PAGES. 6X9 PAPERBACK. ILLUSTRATED. \$16.95. CODE: GDS



DARK MOON

Apollo and the Whistleblowers

by Mary Bennett and David Percy

- Was Neil Armstrong really the first man on the Moon?
- Did you know a second craft was going to the Moon at the same time as Apollo 11?
- Do you know that potentially lethal radiation is prevalent throughout deep space?
- Do you know there are serious discrepancies in the account of the Apollo 13 "accident"?
- Did you know that "live" color TV from the Moon was not actually live at all?
- Did you know that the Lunar Surface Camera had no viewfinder?
- Do you know that lighting was used in the Apollo photographs—yet no lighting equipment was taken to the Moon?

All these questions, and more, are discussed in great detail by British researchers Bennett and Percy in *Dark Moon*, the definitive book (nearly 600 pages) on the possible faking of the Apollo Moon missions. Bennett and Percy delve into every possible aspect of this beguiling theory, one that rocks the very foundation of our beliefs concerning NASA and the space program. Tons of NASA photos analyzed for possible deceptions.

568 PAGES. 6X9 PAPERBACK. ILLUSTRATED. BIBLIOGRAPHY. INDEX. \$25.00. CODE: DMO



TECHNOLOGY OF THE GODS

The Incredible Sciences of the Ancients

by David Hatcher Childress

Popular *Lost Cities* author David Hatcher Childress takes us into the amazing world of ancient technology, from computers in antiquity to the "flying machines of the gods." Childress looks at the technology that was allegedly used in Atlantis and the theory that the Great Pyramid of Egypt was originally a gigantic power station. He examines tales of ancient flight and the technology that it involved; how the ancients used electricity; megalithic building techniques; the use of crystal lenses and the fire from the gods; evidence of various high tech weapons in the past, including atomic weapons; ancient metallurgy and heavy machinery; the role of modern inventors such as Nikola Tesla in bringing ancient technology back into modern use; impossible artifacts; and more.

356 PAGES, 6x9 PAPERBACK, ILLUSTRATED, BIBLIOGRAPHY, \$16.95, CODE: TGD



VIMANA AIRCRAFT OF ANCIENT INDIA & ATLANTIS

by David Hatcher Childress, Introduction by Ivan T. Sanderson

Did the ancients have the technology of flight? In this incredible volume on ancient India, authentic Indian texts such as the *Ramayana* and the *Mahabharata* are used to prove that ancient aircraft were in use more than four thousand years ago. Included in this book is the entire Fourth Century BC manuscript *Vimana Shastru* by the ancient author Maharishi Bharadwaja, translated into English by the Mysore Sanskrit professor G.R. Josyer. Also included are chapters on Atlantean technology, the incredible Rama Empire of India and the devastating wars that destroyed it. Also an entire chapter on mercury vortex propulsion and mercury gyros, the power source described in the ancient Indian texts. Not to be missed by those interested in ancient civilizations or the UFO enigma.

334 PAGES, 6x9 PAPERBACK, ILLUSTRATED, \$15.95, CODE: VAA



LOST CONTINENTS & THE HOLLOW EARTH

I Remember Lemuria and the Shaver Mystery

by David Hatcher Childress & Richard Shaver

Lost Continents & the Hollow Earth is Childress' thorough examination of the early hollow earth stories of Richard Shaver and the fascination that fringe fantasy subjects such as lost continents and the hollow earth have had for the American public. Shaver's rare 1948 book *I Remember Lemuria* is reprinted in its entirety, and the book is packed with illustrations from Ray Palmer's *Amazing Stories* magazine of the 1940s. Palmer and Shaver told of tunnels running through the earth—tunnels inhabited by the Deros and Teros, humanoid forms from an ancient spacefaring race that had inhabited the earth, eventually going underground, hundreds of thousands of years ago. Childress discusses the famous hollow earth books and delves deep into whatever reality may be behind the stories of tunnels in the earth. Operation High Jump to Antarctica in 1947 and Admiral Byrd's bizarre statements, tunnel systems in South America and Tibet, the underground world of Agartha, the belief of UFOs coming from the South Pole, more.

344 PAGES, 6x9 PAPERBACK, ILLUSTRATED, \$16.95, CODE: LCHE

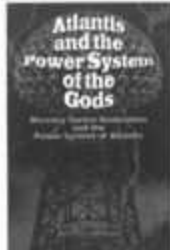

ATLANTIS & THE POWER SYSTEM OF THE GODS

Mercury Vortex Generators & the Power System of Atlantis

by David Hatcher Childress and Bill Clendenon

Atlantis and the Power System of the Gods starts with a reprinting of the rare 1900 book *Mercury: UFO Messenger of the Gods* by Bill Clendenon. Clendenon takes on an unusual voyage into the world of ancient flying vehicles, strange personal UFO sightings, a meeting with a "Man In Black" and then to a centuries-old library in India where he got his idea for the diagrams of mercury vortex engines. The second part of the book is Childress' fascinating analysis of Nikola Tesla's broadcast system in light of Edgar Cayce's "Terrible Crystal" and the obelisks of ancient Egypt and Ethiopia. Includes: Atlantis and its crystal power towers that broadcast energy; how these incredible power stations may still exist today; inventor Nikola Tesla's nearly identical system of power transmission, Mercury Proton Gyros and mercury vortex propulsion, more. Richly illustrated, and packed with evidence that Atlantis not only existed—it had a world-wide energy system more sophisticated than ours today.

246 PAGES, 6x9 PAPERBACK, ILLUSTRATED, \$15.95, CODE: APSG



A HITCHHIKER'S GUIDE TO ARMAGEDDON

by David Hatcher Childress

With wit and humor, popular *Lost Cities* author David Hatcher Childress takes us around the world and back in his trippy finale to the *Lost Cities* series. He's off on an adventure in search of the apocalypse and end times. Childress hits the road from the fortress of Megiddo, the legendary citadel in northern Israel where Armageddon is prophesied to start. Hitchhiking around the world, Childress takes us from one adventure to another, to ancient cities in the deserts and the legends of worlds before our own. Childress muses on the rise and fall of civilizations, and the forces that have shaped mankind over the millennia, including wars, invasions and cataclysms. He discusses the ancient Armageddons of the past, and chronicles recent Middle East developments and their ominous undertones. In the meantime, he becomes a cargo cult god on a remote island off New Guinea, gets dragged into the Kennedy Assassination by one of the "conspirators," investigates a strange power operating out of the Altai Mountains of Mongolia, and discovers how the Knights Templar and their offshoots have driven the world toward an epic battle centered around Jerusalem and the Middle East.

320 PAGES, 6x9 PAPERBACK, ILLUSTRATED, BIBLIOGRAPHY, INDEX, \$16.95, CODE: HGA

[1](#)

The Mahabharata (Torchlight Publishing, 2000), p. 644.

[2](#)

High energy lasers are usually abbreviated, appropriately enough, HEL, and “grasers” are simply “gamma ray amplification by stimulated emission of radiation,” in short, they are gamma ray lasers.

[3](#)

Cited in Steven M. Greer, M.D., *Disclosure: Military and Government Witnesses Reveal the Greatest Secrets in Modern History* (Crozer, Virginia: 2001), pp. 255-256.

[4](#)

Tom Van Flandren, *Dark Matter, Missing Planets, and New Comets: Paradoxes Resolved, Origin Illuminated*, p. 157.

[5](#)

Ibid, p. 157.

[6](#)

Ibid.

[7](#)

Van Flandern, *Dark Matter, Missing Planets, and New Comets*, p. 158.

[8](#)

Ibid, p. 158.

[9](#)

Ibid.

[10](#)

Ibid.

[11](#)

Ibid.

[12](#)

Van Flandern, *Dark Matter, Missing Planets, and New Comets*, p. 157

[13](#)

Ibid, p. 159, emphasis added.

[14](#)

Van Flandern, *Dark Matter, Missing Planets, and New Comets*, pp. 160- 161.

[15](#)

Ibid., p. 228.

[16](#)

Ibid, p. 228.

[17](#)

Ibid., p. 230.

[18](#)

Van Flandern, *Dark Matter, Missing Planets, and New Comets*, p. 216.

[19](#)

Ibid.

[20](#)

Ibid, p. 218.

[21](#)

Van Flandern, *Dark Matter, Missing Planets, and New Comets*, p. 182.

[22](#)

“Planetary region,” i.e., the region inside the orbit of Pluto.

[23](#)

Ibid, p. 183.

[24](#)

Ibid., p. 185.

[25](#)

Van Flandern, *Dark Matter, Missing Planets, and New Comets*, p. 181.

[26](#)

Ibid., p. 191

[27](#)

Ibid, p. 217.

[28](#)

Ibid., pp. 217-218.

[29](#)

Van Flandern, *Dark Matter, Missing Planets, and New Comets*, p. 224.

[30](#)

Ibid., p. 227.

[31](#)

Ibid, p. 226.

[32](#)

Ibid., p. 227. I personally believe that there are other explanations for Jupiter's excess heat. I mention Van Flandern's explanation to highlight the explanatory power of the Exploded Planet Hypothesis. Hoagland believes, however, that since all the planets of the outer solar system exhibit an anomalous excess energy outflow, that the cause must lie in something else, and here I believe he is correct in ascribing the source of this outflow to "hyperdimensional" sources of energy.

[33](#)

Van Flandern, *Dark Matter, Missing Planets, and New Comets*, pp. 156- 157, emphasis added.

[34](#)

Ibid., p. 223.

[35](#)

Van Flandern, *Dark Matter, Missing Planets, and New Comets*, p. 224.

[36](#)

Ibid., p. 227.

[37](#)

Ibid., p. 226.

[38](#)

Van Flandern, *Dark Matter, Missing Planets, and New Comets*, p. 235, emphasis added.

[39](#)

Van Flandern, *Dark Matter, Missing Planets, and New Comets*, pp. 235- 236, emphasis added. I have highlighted the radiometric and polonium problems because other alternative researchers have often pointed to problems in the technique of radiometric dating. It is perhaps possible, in his revised Exploded Planet Hypothesis, that Van Flandern may have abandoned this possibility rather too quickly. But as will be seen, the formulation of the revised theory was based not only on the need to resolve this chronological discrepancy, but also on the need to account for new classes of evidence.

[40](#)

I have added this explanatory phrase to Van Flandern's text, to avoid any confusion that might result from his use of the abbreviation 65 Ma.

[41](#)

Van Flandern, *Dark Matter, Missing Planets, and New Comets*, p. 403, emphasis added.

[42](#)

Van Flandern, *Dark Matter, Missing Planets, and New Comets*, p. 405.

[43](#)

Van Flandern, *Dark Matter, Missing Planets, and New Comets*, p. 407.

[44](#)

Ibid.,

[45](#)

Ibid, p. 408, emphasis added.

[46](#)

It might be the case that these formed a double-planetary system such as that of the Earth-Moon system, but this would seem to pose further difficulties of celestial mechanics.

[47](#)

Van Flandern, *Dark Matter, Missing Planets, and New Comets*, pp. 411- 412, emphasis added.

[48](#)

Van Flandern, *Dark Matter, Missing Planets, and New Comets*, pp. 427- 428.

[49](#)

See my *Giza Death Star Deployed*, pp. 15-18.

[50](#)

Van Flandern, op. cit., p. 432. Obviously, C would have had to have been sufficiently large, at least as large as Mars, in order to retain water. The water may have been original to both satellites - Mars and C - or may have been deposited on them by the explosion of V, or some combination of both.

[51](#)

Ibid, p. 407.

[52](#)

Van Flandern, *Dark Matter, Missing Planets, and New Comets*, p. 427.

[53](#)

Ibid, p. 435. Van Flandern speculates further on the possible civilization of the Mars-Planet C system and on its basic history and extent in the light of the explosions of Planets V at 65 million years ago and Planet C at 3.2 million years ago, on pp. 438-439 of his book.

[54](#)

Van Flandern, *Dark Matter, Missing Planets, and New Comets*, p. 431. Van Flandern means the 65,000,000 years' event. I have stated it in this ambiguous fashion in order to leave open the possibility that it may have been the 3,200,000 years event. As previously noted, Mars during this time could have been home to abundant water, suggesting that it might have procured some or all of this water from the 65,000,000 years' event, or that the 3,200,000 years' event was not large enough to sweep all of its water away in the shock wave of the explosion.

[55](#)

Ibid.

[56](#)

Van Flandern, *Dark Matter, Missing Planets, and New Comets*, p. 233.

[57](#)

Ibid, p. 233.

[58](#)

See, for example, Paul LaViolette, *Subquantum Kinetics*, pp. 62-65, for a discussion of the matter-antimatter symmetry problem.

[59](#)

Van Flandern, op. cit., p. 233.

[60](#)

Van Flandern, *Dark Matter, Missing Planets, and New Comets*, p. 232.

[61](#)

Van Flandern, *Dark Matter, Missing Planets, and New Comets*, p. 226.

[62](#)

Mel and Amy Acheson, "Thunderbolts of the Gods: Does Growing Evidence of an Electric Universe Reveal Previously Hidden Meaning in Ancient Mythology?" in *Forbidden History: Prehistoric Technologies, Extraterrestrial Intervention, and the Suppressed Origins of Civilization*, ed. J. Douglas Kenyon (Rochester, Vermont: Bear and Company), 69-76, p. 69.

[63](#)

Eric J. Lerner, *The Big Bang Never Happened: A Startling Refutation of the Dominant Theory of the Origin of the Universe* (Vintage Books, 1992), p. 42.

[64](#)

Ibid.

[65](#)

Ibid., pp. 42-43.

[66](#)

Eric J. Lerner, *The Big Bang Never Happened*, pp. 44-45.

[67](#)

Ibid., p. 44.

[68](#)

Ibid., p. 45.

[69](#)

Eric J. Lerner, *The Big Bang Never Happened*, p. 46.

[70](#)

Eric J. Lerner, *The Big Bang Never Happened*, p. 47.

[71](#)

Eric J. Lerner, *The Big Bang Never Happened*, p. 232.¹¹ Eric J. Lerner, *The Big Bang Never Happened*, p. 233.

[72](#)

Readers of my *Giza Death Star* trilogy will recall that in the first book of the series, *The Giza Death Star*, I speculated that the Great Pyramid was a harmonic oscillator that was coupled not only to the planet earth, but to the local solar system geometry as well as to the galactic geometry of the Milky Way itself.

[73](#)

Eric J. Lerner, *The Big Bang never Happened*, pp. 196-197, emphasis added.

[74](#)

Eric J. Lerner, *The Big Bang Never happened*, p. 243, emphasis added.

[75](#)

“Cohering”, i.e., lining up the axes of spin of the atoms

[76](#)

For the story of the Bell in more detail, see my *Giza Death Star Deployed*, pp. 121-130, *Reich of the Black Sun*, pp. 331-344, and especially my *SS Brotherhood of the Bell*, particularly pp. 139-308.

[77](#)

Eric J. Lerner, *The Big Bang Never Happened*, p. 243.

[78](#)

Ibid., p. 245.

[79](#)

Eric J. Lerner, *The Big Bang Never Happened*, p. 244.

[80](#)

Eric J. Lerner, *The Big Bang Never Happened*, pp. 246, 247, emphasis added.

[81](#)

Q.v. my *SS Brotherhood of the Bell*, pp. 180-181.

[82](#)

As I also point out in *The SS Brotherhood of the Bell*, the idea may actually go all the way back to German scientific work in the 1920s! Q. v. *The SS Brotherhood of the Bell*, pp. 272-308.

[83](#)

The following material is excerpted verbatim from pages 212-220 of my *SS Brotherhood of the Bell*.

[84](#)

E.T. Whittaker, “On the partial differential equations of mathematical physics,” *Mathematische Annalen*, Vol 57, 1903 (333-355), p. 355, italicized emphasis mine, bold and italicized emphasis Whittaker’s.

[85](#)

Bearden, “Maxwell’s Original Quaternion Theory was a Unified Field Theory of Electromagnetic and Gravitation,” *Proceedings of the international Tesla Society*, 6/24-6/68, p. 6/24.

[86](#)

Bearden, *Energy from the Vacuum*, p. 145, bold and italicized emphasis Bearden’s, italicized emphasis mine.

[87](#)

Bearden, *Fer De Lance*, p. 27. For more on CSRs, see pp. 15-16.

[88](#)

Ibid., p. 112, bold and italicized emphasis Bearden’s, italicized emphasis mine.

[89](#)

Ibid., p. 173.

[90](#)

I am *acutely* aware of over-simplifying so much of Bearden’s (and others’) thinking here.

[91](#)

Bearden, *Energy from the Vacuum*, p. 244.

[92](#)

This paragraph is the end of the excerpted material from my *SS Brotherhood of the Bell*.

[93](#)

Bearden, *Fer De Lance*., p. 209, emphasis added.

[94](#)

Ibid., pp. 209-210, emphasis added. Readers of my *Giza Death Star* trilogy will recall that I indicated that one characteristic of a scalar weapon of “mass destruction” planet-busting potential was precisely that it be coupled to the base solar system that it is in. Q.v. my *Giza Death Star*, pp. 251-252. The reason for this requirement, once again, is that large masses are natural resonators to scalar waves.

[95](#)

See my *Giza Death Star Deployed*, *Giza Death Star Destroyed*.

[96](#)

Bearden, *Fer De Lance*, p. 408, emphasis is Bearden's.

[97](#)

Anthony L. Peratt, "Evidence for an Intense Aurora Recorded in Antiquity," and D. Scott and A. I. Peratt, "The Origin of Petroglyphs - Recordings of a Catastrophic Aurora in Human Prehistory, *ICOPS 2003; the 30th Annual International IEEE Conference on Plasma Science*, June 3-5, 2003, Jeju, Korea; and his seminal paper in this field, "Characteristics for the Occurrence of a High Current, Z-Pinch Aurora as Recorded in Antiquity," *IEEE Transactions on Plasma Science*, Vol. 31, No. 6, Dec. 2003, pp. 1192-1214.

[98](#)

According to the brief biography of Peratt attached to his article "Characteristics for the Occurrence of a High-Current, Z-Pinch Aurora as Recorded in Antiquity," *IEEE Transactions on Plasma Science*, Vol. 31, No. 6, Dec. 2003, pp. 1192-1214, Peratt was a staff member of Los Alamos from 1971- 79, and from 1981 to the present. He was also a guest physicist with the prestigious *Max Planck Institut für Plasmaphysik* in Germany and was a Guest Scientist with the Alfvén Laboratory of the Royal Institute of Technology in Stockholm, Sweden.

[99](#)

Ibid., p. 1214.

[100](#)

Peratt, "Evidence for an Intense Aurora Recorded in Antiquity."

[101](#)

Peratt, "The Origins of Petroglyphs - Recordings of a Catastrophic Aurora in Human Prehistory."

[102](#)

Peratt, "Characteristics for the Occurrence of a High-Current, Z-Pinch Aurora as Recorded in Antiquity," from the Abstract, *IEEE Transactions on Plasma Science*, p. 1192.

[103](#)

Ibid.

[104](#)

Peratt, "Characteristics for the Occurrence of a High Current, Z-Pinch Plasma as Recorded in Antiquity," p. 1193.

[105](#)

Ibid.

[106](#)

Ibid.

[107](#)

Ibid., p. 1194.

[108](#)

Ibid. p. 1194. Readers of my previous book, *The SS Brotherhood of the Bell*, will no doubt recall my argument there, contra Witkowski, that the Bell was also a *pulsed* device. The creation of electrodynamic shock waves of this type depends on it.

[109](#)

Ibid.

[110](#)

To my knowledge, Peratt does not advance a reason for the selection of this age range. Peratt lists an extensive range of data and sites that his data was collected from on p. 1198.

[111](#)

For example most people date the Flood to approximately 10,000 BC. Plato fixes the destruction of Atlantis ca. 9,600 BC, and so on.

[112](#)

Peratt's comparisons cannot easily be reproduced here due to the difficulty of graphic reproduction of his small illustrations. For those wishing to read Peratt's own commentary and reproductions, these may be found on pp. 1199-1212 of his article, "Characteristics for the Occurrence of a High-Current, Z-Pinch Aurora as Recorded in Antiquity." Talbott and Thornhill convincingly expand Peratt's methodology to a consideration of plasma geometries depicted in ancient coins, statues, and other art works.

[113](#)

Mel and Amy Acheson, "Thunderbolts of the Gods: Does Growing Evidence of an Electric Universe Reveal Previously Hidden Meaning in Ancient Mythology?", *Forbidden History: Prehistoric Technologies, Extraterrestrial Intervention, and the Suppressed Origins of Civilization*, ed. J. Douglas Kenyon, (Bear and Co.), p. 72.

[114](#)

Mel and Amy Acheson, "Thunderbolts of the Gods," *Forbidden History*, p. 73.

[115](#)

Mel and Amy Acheson, "Thunderbolts of the Gods: Does Growing Evidence of an Electric Universe Reveal Previously Hidden Meaning in Ancient Mythology?" p. 76.

[116](#)

Mel and Amy Acheson, "Thunderbolts of the Gods: Does Growing Evidence of an Electric Universe Reveal Previously Hidden Meaning in Ancient Mythology?" p. 74.

[117](#)

Ibid., p. 75.

[118](#)

Ibid.

[119](#)

Mel and Amy Acheson, “Thunderbolts of the Gods: Does Growing Evidence of an Electric Universe Reveal Previously Hidden Meaning in Ancient Mythology?”p.75.

[120](#)

Ibid., p. 76.

[121](#)

Ibid.

[122](#)

It will be recalled that a similar contradiction was evidenced in the collision of the parameters of Van Flandern’s initial Exploded Planet Hypothesis, which indicated that the explosion of the planet that became the asteroid belt occurred ca. 3.2 million years ago, whereas the terrestrial geological record could only support such an event occurring approximately 65 million years ago.

[123](#)

It is my belief that the peculiar plasma phenomena Alfvén encountered in the Sweden’s mercury rectifiers, and that Bostick accessed in his plasma focus device, and that the Nazis accessed with their “Bell” device, was scalar in nature, i.e., that the plasma phenomena are signatures of a deeper underlying physics and topological principle.

[124](#)

Other legends also point to Jupiter and Saturn as being implicated in the events.

[125](#)

Immanuel Velikovsky, *Worlds in Collision*, Dell, 1971, p. 59.

[126](#)

Alan Alford, *The Atlantis Secret*, p. 264.

[127](#)

Velikovsky, *Worlds in Collision*, p. 59.

[128](#)

Ibid.

[129](#)

Alan Alford, *The Atlantis Secret*, p. v, emphasis added.

[130](#)

Alford, *The Atlantis Secret*, p. 159.

[131](#)

Ibid.

[132](#)

Ibid., p. 194.

[133](#)

Alford, *When the Gods Came Down*, p. 114.

[134](#)

Ibid., p. 120, citing A. Heidel, *The Gilgamesh Epic and Old Testament Parallels*, pp. 17-18.

[135](#)

Alford, *When the Gods Came Down*, p. 126.

[136](#)

Ibid., p. 179, emphasis in the original.

[137](#)

Ibid., p. 245.

[138](#)

Alford, *When the Gods Came Down*, p. 370.

[139](#)

Alford, *When the Gods Came Down*, p. 37.

[140](#)

Ibid, p. 70, italicized emphasis original, bold and italicized emphasis added.

[141](#)

Q.v. my *Giza Death Star Destroyed*, pp. 33-34.

[142](#)

Talbott and Thornhill, *Thunderbolts of the Gods*, p. 79.

[143](#)

One must mention the various attempts to bridge this gap via the non-equilibrium thermodynamics of Ilya Prigogine and various chaos theorists, who cite the examples of various systems, including plasma systems, to self-organize under extreme conditions of non-equilibrium. Such attempts may provide an adequate theoretical foundation to bridge this gap *physically*, but they still do not dispense with the *textual* component of the problem, for as LaViolette and others have noted, there is ample paleographical and textual evidence to suggest that the a sophisticated physics might once have been in existence in paleoancient times. Q.v. my *Giza Death Star*, pp. 38-110, *Giza Death Star Deployed*, pp. 60-76, and *Giza Death Star Destroyed*, pp 21-52, 99-174, 222- 246. These attempts to explain this celestial “gap” theory only highlight the fact, in a very sophisticated and subtle way, that there may have once been a similarly sophisticated physics. And that, of course, only raises the problem of a lost Very High Civilization in a new guise.

[144](#)

Consider just the differences between scholarly and well-argued interpretations of such ancient myths as Sitchin's, Santillana-Dechind's (*Hamlet's Mill*), Van Flandern's, LaViollette's, Gardner's, and Alford's.

[145](#)

Joseph P. Farrell, *The Giza Death Star Destroyed*, pp. 49-50

[146](#)

Stephen Quayle, *Genesis 6 Giants: Master Builders of Prehistoric and Ancient Civilizations*, p. 182.

[147](#)

Saint Augustine (of Hippo), "Concerning the long life of men before the flood, and the greater size of their bodies," Chapter XI, pp. 322-325, cited in Stephen Quayle, *Genesis 6 Giants: Master Builders of Prehistoric and Ancient Civilizations*, pp. 250-251.

[148](#)

Quayle, op. cit., p. 250.

[149](#)

Ibid.

[150](#)

An early Latin ecclesiastical writer.

[151](#)

Quayle, op. cit., p. 236, citing Paul Pezron, *Antiquities of Nations*, pp. 74- 75.

[152](#)

Quayle, op. cit., p. 239. I cite Quayle's work as the primary source for this material since Pezron's work is more difficult to obtain.

[153](#)

Ibid., p. 240.

[154](#)

Ibid.

[155](#)

Ibid., p. 241.

[156](#)

Ibid., p. 241, citing Pezron, p. 51.

[157](#)

Quayle, op. cit., p. 213.

[158](#)

John F Healy, trans. and ed., *Pliny the Elder — Natural History — A Selection* (Penguin Books).

[159](#)

Quayle, op cit., p. 214.

[160](#)

Quayle, op cit., p. 216.

[161](#)

Ibid., p. 217.

[162](#)

Ibid., p. 231.

[163](#)

Ibid., p. 232.

[164](#)

Quayle, op. cit., p. 235.

[165](#)

Ibid., p. 190.

[166](#)

Ibid., p. 197.

[167](#)

Ibid., pp. 197-198.

[168](#)

Quayle, op. cit., p. 198.

[169](#)

Ibid., p. 191, citing David Hatcher Childress, *Lost Cities of North America*, Adventures Unlimited Press, p. 509.

[170](#)

Ibid., citing Childress, *Lost Cities of North America*, Adventures Unlimited Press, p. 509.

[171](#)

Ibid., p. 192, citing *Historical Collections of Ohio in Two Volumes*, (Noble County Ohio) pp. 350-351.

[172](#)

Quayle, op. cit., p. 192, citing *Chicago Record*, October 24, 1895.

[173](#)

Quayle, op. cit., p. 192, citing *The Humboldt Star*, May 13, 1928, and Childress, *Lost Cities of North America*, p. 193.

[174](#)

Ibid., p. 193, citing Childress, p. 526.

[175](#)

Numbers, 13:32.

[176](#)

Quayle, op. cit., p. 200.

[177](#)

Quayle, op. cit., p. 208.

[178](#)

Ibid.

[179](#)

Ibid.

[180](#)

Quayle, op. cit., p. 93.

[181](#)

Quayle, op. cit., p. 195, citing Childress, *Lost Cities of North America*, p. 353.

[182](#)

Quayle, op. cit., p. 196, citing John J. Miller, "Roots — Deep Ones," *National Review*, June 9-10, 2001.

[183](#)

Quayle, op. cit., p. 204, emphasis added.

[184](#)

Quayle, op. cit., p. 194, emphasis added.

[185](#)

Giorgio de Santillana and Hertha von Dechind, *Hamlet's Mill: An Essay on Myth and the Frame of Time* (Boston: Gambit Incorporated, 1969), p. 262.

[186](#)

Paul LaViolette, *The Talk of the Galaxy: An ET Message for Us?* (Alexandria, VA: Starlane Publications, 2000), p. 15.

[187](#)

James M. McCanney, *Atlantis to Tesla: The Kolbrin Connection: The Science of Atlantis and Tesla are Rediscovered, Giving a Unique Untold View of Life on the Lost Continent, Ancient Space Craft Design, Unlimited Electrical Power, and the Secret Societies* (Minneapolis, Minnesota: jmmccanneyscience.com press, 2003), p. 29.

[188](#)

Q.v., *The Giza Death Star*, pp. 66-110, *The Giza Death Star Destroyed*, pp. 196-245.

[189](#)

De Santillana and Von Dechind, *Hamlet's Mill*, p. 5.

[190](#)

Ibid.

[191](#)

De Santillana and Von Dechind, *Hamlet's Mill*, pp. 56-57, emphasis added.

[192](#)

Ibid., p. 64. Their remarks here were said specifically in reference to Stoic physics, but understood as a symbol for the “archaic cosmological view” as a whole.

[193](#)

Ibid.

[194](#)

De Santillana and Von Dechind, p. 58.

[195](#)

Q.v. my *the Giza Death Star*, chapter three, “The Paleography of Paleophysics.

[196](#)

De Santillana and Von Dechind, p. 235, emphasis added.

[197](#)

De Santillana and Von Dechind, *Hamlet's Mill*, p. 232.

[198](#)

Ibid.

[199](#)

Q.v. my *The Giza Death Star Destroyed*, pp. 37-52.

[200](#)

Ibid.,

[201](#)

De Santillana and Von Dechind, *Hamlet's Mill*, p. 262.

[202](#)

Ibid., p. 78.

[203](#)

Enki, the Babylonian name.

[204](#)

Yima, the Persian-Zoroastrian name.

[205](#)

Freyr, the Norse name.

[206](#)

De Santillana and Von Dechind, *Hamlet's Mill*, p. 153.

[207](#)

De Santillana and Von Dechind, *Hamlet's Mill*, p. 154, emphasis added.

[208](#)

Ibid, p. 156.

[209](#)

Ibid.

[210](#)

It should be noted that the Hindu epics are full of references to the divine “arrows” and “thunderbolts,” e.g., the thunderbolt of Indra. Q.v. De Santillana and Von Dechind, *Hamlet's Mill*, p. 166.

[211](#)

In this respect, De Santillana and Von Dechind understand the Era epic of Mesopotamia to refer precisely to a celestial Deluge. Q.v. *Hamlet's Mill*, p. 323. And there are any number of references in Alford to “waters in the heavens.:

[212](#)

James M. McCanney, *Atlantis to Tesla: The Kolbrin Connection*, p. 13.

[213](#)

James M. McCanney, *Atlantis to Tesla: The Kolbrin Connection*, p. 13. He also states immediately afterward, without offering any substantiation, that these same intelligence people “are the same people who sponsor secret missions to Mars and who are in charge of absconding with priceless archaeological treasures from around the world in search of ancient technologies...”

[214](#)

Paul La Violette, *The Talk of the Galaxy*, p. 1.

[215](#)

Ibid.

[216](#)

Ibid., p. 2.

[217](#)

Ibid.

[218](#)

La Violette, *The Talk of the Galaxy*, p. 3, emphasis added by La Violette. ³⁵ Ibid., p. 8.

[219](#)

LaViolette, *The Talk of the Galaxy*, p. 15.

[220](#)

Ibid., p. 16.

[221](#)

Ibid.

[222](#)

La Violette, *The Talk of the Galaxy*, p. 17.

[223](#)

Ibid., p. 19, emphasis added.

[224](#)

La Violette, *The Talk of the Galaxy*, p. 22, emphasis in the original.

[225](#)

Ibid., p. 22.

[226](#)

Ibid., pp. 24-25, emphasis in the original.

[227](#)

Ibid., pp. 29-30.

[228](#)

La Violette, *The Talk of the Galaxy*, p. 33, emphasis added.

[229](#)

Ibid., pp. 33-34.

[230](#)

La Violette, *The Talk of the Galaxy*, p. 34, emphasis added.

[231](#)

As I note in my work *The Giza Death Star*, Nikola Tesla noticed a similar effect of these electro-acoustic or electrical longitudinal waves, in that they would travel through shielding of all sorts with very little diminution of force or dispersion of energy.

[232](#)

La Violette, op. cit., p. 35.

[233](#)

This phenomenon I chose to call “electro-acoustic”, and Tesla often referred to it by a variety of names.

[234](#)

LaViolette, op. cit., p. 35.

[235](#)

Laviolette, *The Talk of the Galaxy*, p. 35.

[236](#)

Ibid., pp. 39-40.

[237](#)

LaViolette, *The Talk of the Galaxy*, p. 48.

[238](#)

De Santillana and Von Dechind, *Hamlet's Mill*, p. 166.

[239](#)

The Tower of Babel is discussed elsewhere in this book, and in my *Giza Death Star Destroyed*, 77-78.

[240](#)

LaViolette, *The Talk of the Galaxy*, p. 65.

[241](#)

Ibid., p. 66.

[242](#)

Ibid.

[243](#)

Ibid, emphasis added.

[244](#)

LaViolette, *The Talk of the Galaxy*, p. 95.

[245](#)

Ibid. p. 120.

[246](#)

La Violette, *The Talk of the Galaxy*, p. 121, emphasis added.

[247](#)

Ibid., p. 127, emphasis added.

[248](#)

La Violette, *The Talk of the Galaxy*, p. 132, emphasis added.

[249](#)

And the Nazi one, for readers of my book *The SS Brotherhood of the Bell* will recall the late war German radar wave-mixing experiments on their nonlinear Radar Absorbent Material. The major difference between the German experiments and the modern one is that the German radars were not cohered.

[250](#)

As noted in chapter two, p. 46, Bearden indicates that any large mass is a natural resonator of scalar waves.

[251](#)

La Violette, *The Talk of the Galaxy*, p. 132.

[252](#)

La Violette, *The Talk of the Galaxy*. 132-134, emphasis in the original.

[253](#)

The Mahabharata, trans. Krishna Dharma, p. 402.

[254](#)

Ibid., p. 590.

[255](#)

E. A. E. Reymond, *The Mythical Origin of the Egyptian Temple* (Manchester University Press, 1969), p. 229.

[256](#)

Andrew Collins, *Gods of Eden: Egypt's Lost Legacy and the Genesis of Civilization* (Bear and Co., 2002), p. 37.

[257](#)

Ibid., p. 93.

[258](#)

Stephanie Dalley, *Myths from Mesopotamia*, p. 3.

[259](#)

Ibid., p. 9.

[260](#)

Ibid., p. 10.

[261](#)

Dalley, *Myths from Mesopotamia*, p. 12.

[262](#)

Ibid., p. 14.

[263](#)

Ibid., p. 4.

[264](#)

Dalley, *Myths from Mesopotamia*, p. 15.

[265](#)

Ibid., p. 15.

[266](#)

Ibid., p. 4.

[267](#)

Dalley, *Myths from Mesopotamia*, p. 16.

[268](#)

Dalley, *Myths from Mesopotamia*, p. 18.

[269](#)

Ibid., p. 5.

[270](#)

Dalley, *Myths from Mesopotamia*, p. 19.

[271](#)

Dalley, *Myths from Mesopotamia*, pp. 20-21.

[272](#)

Ibid., p. 26.

[273](#)

Igigi is the term for mankind.

[274](#)

He: reading the text carefully, it is unclear whether “he” refers to Enki, or to the new worker, or to both.

[275](#)

Presumably the chain of the gods having to labor so hard prior to the hybrid’s creation.

[276](#)

Dalley, *Myths from Mesopotamia*, p. 27.

[277](#)

“Your people,” i.e., the hybrid human race.

[278](#)

As will be seen in the next chapter, Erakal is another name for the god Nergal.

[279](#)

Dalley, *Myths from Mesopotamia*. pp. 28-29. As will also be seen in the next chapter, there is some basis for the idea that Nergal and Ninurta might be closely associated or even assimilated.

[280](#)

Ibid., pp. 29-30.

[281](#)

Dalley, *Myths from Mesopotamia*, p. 31.

[282](#)

Dalley, *Myths from Mesopotamia*, pp. 287-288.

[283](#)

Ibid., p. 289.

[284](#)

Dalley, *Myths from Mesopotamia*, p. 290, emphasis added.

[285](#)

Enuma Elish, ed. L. W. King, M.A., F.S.A, Vol. I I(London: Luzac and Co., 1902), p. 3, Tablet 1 p.3(the numbers of verses are from the edition cited.)

[286](#)

The Giza Death Star, pp. 38-41.

[287](#)

Enuma Elish, Tablet 1, p. 7.

[288](#)

Ibid., Tablet 1, p. 11.

[289](#)

Enuma Elish, Tablet 1, p. 17, emphasis added.

[290](#)

Ibid., Tablet 1, p. 19, emphasis added.

[291](#)

Similar hybrids have been seriously proposed for various purposes in modern literature, including military uses. This “genetic state of affairs” of creating or mingling various species is one reason given in the Old Testament for the Flood for the destruction of the world, since the “gods” had descended to earth and sired children with humans. It is suggested again as a possible motivation for the 2nd world-wide destruction by Christ: “As in the days of Noah...”.

[292](#)

Enuma Elish, Tablet 1, 0. 21, emphasis added, q.v. also Tablet 2: vv. 43- 45, p. 29.

[293](#)

Enuma Elish, Tablet 4:, p. 59.

[294](#)

Ibid., Tablet 4, p. 61.

[295](#)

Enuma Elish. Tablet 4, p. 61.

[296](#)

Ibid., Tablet 4, p. 61, emphasis added.

[297](#)

Ibid., Tablet 4, p. 63, emphasis added.

[298](#)

q.v. Zechariah Sitchin, *The Wars of Gods and Men*, (Avon Books), pp. 163-172. See also the first book in this series, *The Giza Death Star*, pp. 45-56.

[299](#)

The Giza Death Star, pp. 95-96

[300](#)

Enuma Elish, Tablet 4, p. 65, emphasis added.

[301](#)

Ibid., Tablet 4, p. 67.

[302](#)

Ibid., Tablet 4, p. 69.

[303](#)

Ibid., Tablet 4, p. 71, emphasis added.

[304](#)

Enuma Elish, Tablet 4: vv. 105-112, p. 73.

[305](#)

Ibid., Tablet 4, p. 75.

[306](#)

Ibid., p. 77.

[307](#)

As was seen in chapter five and the pulsar grid of La Violette, such a physics would seem to exist.

[308](#)

The subject of a solar system catastrophe and the immediate need for the surviving civilizations to quickly and easily re-measure astronomical data, and to be able to teach simple people how to build such observatories, is the subject of a fascinating book by Christopher Knight and Robert Lomas called *Uriel's Machine: Uncovering the Secrets of Stonehenge, Noah's Flood, and the Dawn of Civilization*.

[309](#)

The significance of this point may be lost unless one realizes that in many seminaries, as a component of learning “biblical criticism,” for example, or as a component of ancient comparative religions courses, the *Enuma Elish* and epics such as Gilgamesh are used to point out the similarities of the Biblical with the Babylonian accounts, and in some instances, to posit the reliance of the former upon the latter. However, if the *Enuma Elish* is *not* understood as a creation epic disguised in a war metaphor, but as a very real account of a very real war, the comparison would seem to collapse. As will be apparent in a subsequent chapter, there is another way of viewing the Sumerian and Biblical traditions as components of a whole.

[310](#)

The clear association of Marduk and Ninurta with the Great Pyramid was one feature of Sitchin's reading of the *Lugal-e*.

[311](#)

Joseph P. Farrell, *The Giza Death Star Deployed*, pp. 37-49.

[312](#)

Dalley, *Myths from Mesopotamia*, p. 291.

[313](#)

Dalley, *Myths from Mesopotamia*, p. 291.

[314](#)

Dalley, *Myths from Mesopotamia*, pp. 291-292

[315](#)

Ibid., p. 292. Perhaps instead of “be obscured” one might say “will stop”, indicating the cessation of life to be brought about by this new deluge.

[316](#)

Dalley, *Myths from Mesopotamia*, p. 293.

[317](#)

Ibid., p. 302.

[318](#)

Ibid.

[319](#)

Ibid., p. 304.

[320](#)

Dalley, *Myths from Mesopotamia*, p. 307.

[321](#)

Ibid., p. 308.

[322](#)

Andrew Collins, *Gods of Eden*, p. 173.

[323](#)

E.A.E. Reymond, *The Mythical Origins of the Egyptian Temple*, p. 4.

[324](#)

Ibid.

[325](#)

Collins, *Gods of Eden*, p. 173.

[326](#)

Ibid., p. 174.

[327](#)

Ibid., emphasis added.

[328](#)

Ibid.

[329](#)

Q.v. my *Giza Death Star*, pp. 56-58.

[330](#)

Collins, *Gods of Eden*, p. 174.

[331](#)

Ibid.

[332](#)

Ibid., pp. 174-175. This curious fact indicates clearly that one is dealing specifically with the paleophysics of the primary scission: see my *Giza Death Star Destroyed*, pp. 106-110, 222-245.

[333](#)

Ibid., p. 175.

[334](#)

Ibid., emphasis added.

[335](#)

Q.v. my *Giza Death Star Destroyed*, pp. 10-14.

[336](#)

E.A.E. Reymond, *The Mythical Origins of the Egyptian Temple*, p. 13.

[337](#)

Ibid.

[338](#)

Ibid., p. 10.

[339](#)

Reymond, *The Mythical Origins of the Egyptian Temple*, p. 19.

[340](#)

Reymond, *The Mythical Origins of the Egyptian Temple*, p. 35.

[341](#)

Ibid., p. 60.

[342](#)

Ibid., p. 113.

[343](#)

See my *The Giza Death Star Destroyed*, pp. 8-9.

[344](#)

Q.v. Reymond, *The Mythical Origins of the Egyptian Temple*, p. 108.

[345](#)

Q.v. my *The Giza Death Star Destroyed*, p.8.

[346](#)

Reymond, *The Mythical Origins of the Egyptian Temple*, pp. 91-92.

[347](#)

Collins, *Gods of Eden*, p. 175.

[348](#)

Ibid., p. 176.

[349](#)

Ibid.

[350](#)

Collins, p. 177, italicized emphasis added, bold and italicized emphasis in the original.

[351](#)

Q.v. *Giza Death Star Destroyed*, pp. 222-245.

[352](#)

See my *The Giza Death Star*, pp. 42-56.

[353](#)

Collins, *Gods of Eden*, p. 177, emphasis added.

[354](#)

See my *The Giza Death Star Deployed*, pp. 25-38.

[355](#)

Against this view, however, it should be stated that Collins remarks that “these additional building phases are not necessarily to be seen as later events, since the texts are often mixed up, duplicated and confused and may therefore refer to events relating to the first two period of creation.” (p. 177) This would seem to argue my point, however, that the initial phases are “paleoancient”, i.e., perhaps millions of years old.

[356](#)

Collins, *Gods of Eden*, p. 177.

[357](#)

E. A. E. Reymond, *The Mythical Origin of the Egyptian Temple* (Manchester University Press, 1969), p. 229.

[358](#)

Collins, *The Gods of Eden*, p. 178.

[359](#)

Ibid., p. 179.

[360](#)

Ibid., p. 180.

[361](#)

Ibid.

[362](#)

Collins, *Gods of Eden*, p. 180, emphasis in the original.

[363](#)

Ibid., p.180.

[364](#)

Ibid.

[365](#)

Ibid., p. 181, emphasis added.

[366](#)

Peter Goodgame, "The Myth and Religion of Osiris the God," *The Giza Discovery Part Two*, www.redmoonrising.com/Giza/OsirisMyth2.htm, p. 6.

[367](#)

Ibid., p. 7

[368](#)

Collins, *The Gods of Eden*, p. 194.

[369](#)

Ibid., p. 195, emphasis added.

[370](#)

Collins, *The Gods of Eden*, p. 196.

[371](#)

Faulkner, *The Ancient Egyptian Coffin Texts*, spell 1080, p, 147, cited in Collins, *The Gods of Eden*, pp. 196-197.

[372](#)

Collins, *The Gods of Eden*, p. 197.

[373](#)

Collins, *The Gods of Eden*, p. 60.

[374](#)

Ibid.

[375](#)

Ibid., p. 61.

[376](#)

Ibid., p. 62.

[377](#)

Ibid., pp. 66-71.

[378](#)

Ibid., p. 93. The phenomenon is not, however, as mysterious as it would first appear to be, for one of the implications of scalar physics is the ability of an object, under the right geometrical configuration, to *structure* the local potential of the medium. This would include the “inventor” himself as a component, in some circumstances, of this geometry. When the invention is *moved*, or *operated by someone else*, it loses this local structuring of the potential. This is a phenomenon dealt with at some length by Bearden in various papers.

[379](#)

The text cited is from Hans Gustav Gunterbock, trans., “The Song of Ullikummi: Revised Text of the Hittite version of a Hurrian Myth,” *Oriental Institute* (University of Chicago, New Haven, CT: The American Schools of Oriental Research, 1952).

[380](#)

“This child”, i.e., Ullikummi

[381](#)

David Hatcher Childress, *Lost Cities of Ancient Lemuria and the Pacific*, p.

[382](#)

Most likely a reference to Baal.

[383](#)

<http://earth-history.com/Sumer/sumer-sumer-kinglist.htm> Emphasis added.

[384](#)

R.A. Boulay, *Flying Serpents and Dragons*, pp. 56-57.

[385](#)

Ibid., p. 57.

[386](#)

Alternatively, if one takes Van Flandern’s figure, 65,000,000 years ago, and divides it by 120 and then again in half, one obtains 270,833 years ago, roughly the same time frame as the antediluvian reigns of the Sumerian kings.

[387](#)

Frank Joseph, "Giron-Gagal," *The Atlantis Encyclopedia*, p. 123.

[388](#)

Ibid.

[389](#)

Frank Joseph., "Okinoshima," *The Atlantis Encyclopedia*, p. 212

[390](#)

Frank Joseph, "Alatuir," *The Atlantis Encyclopedia*, pp. 17-18.

[391](#)

Frank Joseph, "Chintamani," *The Atlantis Encyclopedia*, pp. 86-87.

[392](#)

Once again I am using the term "Sumerian" as a symbol or shorthand of the Mesopotamian tradition.

[393](#)

Stephanie Dalley, *Myths from Mesopotamia* (Oxford, 2000), p. 163.

[394](#)

Q.v. my *Giza Death Star Destroyed* (Adventures Unlimited Press, 2005), pp. 10-20.

[395](#)

Stephanie Dalley, *Myths from Mesopotamia*, pp. 170, 175.

[396](#)

Ibid., p. 180.

[397](#)

Ibid., p. 203.

[398](#)

Stephanie Dalley, *Myths from Mesopotamia*, p. 203.

[399](#)

Ibid., p. 204.

[400](#)

Ibid., emphasis added.

[401](#)

Ibid., p. 314, n. 37.

[402](#)

Ibid., p. 205, emphasis added.

[403](#)

Q.v. *The Book of Enoch*.

[404](#)

Q.v. my *The Giza Death Star Destroyed*, pp. 10-20.

[405](#)

Dalley, *Myths from Mesopotamia*, p. 317.

[406](#)

Dalley, *Myths from Mesopotamia*, p. 321.

[407](#)

Ibid.

[408](#)

The biblical echoes are found in:

[409](#)

Dalley, *Myths from Mesopotamia*, p. 321.

[410](#)

Ibid., p. 322.

[411](#)

Ibid., p. 325.

[412](#)

Ibid., p. 326.

[413](#)

Joseph P. Farrell, *The Giza Death Star Destroyed*, pp. 77-78.

[414](#)

Stephanie Dalley, *Myths from Mesopotamia*, p. 205.

[415](#)

Dalley, *Myths from Mesopotamia*, p. 206.

[416](#)

Q.v. my *The Giza Death Star Destroyed*, pp. 37-49.

[417](#)

Dalley, *Myths from Mesopotamia*, p. 207, emphasis added.

[418](#)

Ibid.

[419](#)

Q.v. my *Giza Death Star Deployed*, pp. 37-49.

[420](#)

Dalley, *Myths from Mesopotamia*, p. 208.

[421](#)

Ibid., p. 208, emphasis added.

[422](#)

It should be emphasized in this connection that scalar physics is inclusive of a strong biophysical component as well as of a consciousness component.

[423](#)

Dalley, *Myths from Mesopotamia*, p. 208.

[424](#)

Dalley, *Myths from Mesopotamia*, pp. 210-212.

[425](#)

Dalley, *Myths from Mesopotamia*, pp. 213-214.

[426](#)

Dalley, *Myths from Mesopotamia*, p. 214, emphasis added.

[427](#)

Dalley, op. cit., p. 214, emphasis added.

[428](#)

The fact that most pyramids are planetary analogues should be recalled, as well as the fact that the pyramidal analogue of the Earth par excellence is the Great Pyramid.

[429](#)

Dalley, *Myths from Mesopotamia*, p. 215.

[430](#)

Ibid., p. 218, emphasis added.

[431](#)

R.A. Boulay, *Flying Serpents and Dragons*, p. 83, emphasis added.

[432](#)

<http://earth-history.com/Sumer/sumer-ninurta-exploits.htm>, p. 8.

[433](#)

<http://earth-history.com/Sumer/sumer-ninurta-exploits.htm>, pp. 8-15, emphases added.

[434](#)

This acoustic component is loose corroboration of my speculation that the Great Pyramid represented a weaponized “scalar” technology using longitudinal waves in the medium, “electro-acoustic” waves, as its primary punch. Such types of waves would be one clear contender for the necessary power to blow up a planet.

[435](#)

In my *Giza Death Star Destroyed*. I indicated that such electrostatic displays would be a secondary signature of scalar effects being manipulated on a planetary scale.

[436](#)

In this context it is interesting to contemplate once again the strange episodes that preceded and immediately followed the Anglo-American assault on Iraq to deny Saddam Hussein the perfection of his alleged “weapons of mass destruction.” It is well known that prior to the invasion, France and Germany had teams of archaeologists assisting the Bathist regime to recover and catalogue a number of important archaeological finds and sites in the country. Might Hussein’s alleged “weapons of mass destruction” have been the code for something more than just chemical, biological, or nuclear weapons? We will never know for sure, but it is perhaps illuminating to recall the “Baghdad Museum Incident” shortly after the city was captured by American forces. Several priceless ancient artifacts, with some ancient texts presumably among them, disappeared for a period of a few days, and then were suddenly “recovered” and restored to the museum, giving the thieves enough time, perhaps, to copy or take pictures of whatever items they had stolen, or to substitute other items in their place which were subsequently recovered and returned.

[437](#)

R.A. Boulay, *Flying Serpents and Dragons*, p. 79.

[438](#)

R.A. Boulay, *Flying Serpents and Dragons*, p. 79.

[439](#)

Ibid., p. 80.

[440](#)

Stephanie Dalley, *Myths from Mesopotamia*, p. 329.

[441](#)

De Santillana and Von Dechind, *Hamlet’s Mill*, p. 324.

[442](#)

Dalley, *Myths from Mesopotamia*, p. 326.

[443](#)

Q.v. my comments in *The Giza Death Star Destroyed*, pp. 77-78, where I suggest a connection between the Tower of Babel and the Great Pyramid.

[444](#)

For a summary of these dimensions, see my *Giza Death Star*, pp. 161-179, and Peter Tompkins, *Secrets of the Great Pyramid*, pp. 361-382.

[445](#)

Sir E.A. Wallis Budge, *Amulets and Superstitions: The Original Texts with Translations and Descriptions of a Long Series of Egyptian, Sumerian, Assyrian, Hebrew, Christian, Gnostic and Muslim Amulets and Talismans and Magical Figures, with Chapters on the Evil Eye, The Origin of the Amulet, The Pentagon, the Swastika, the Cross (Pagan and Christian), the Properties of Stones, Rings, Divination, Numbers, the Kabbalah, Ancient Astrology, etc.* (Oxford University Press, 1930), p. 406, emphasis added.

[446](#)

Budge, *Amulets and Superstitions*, p. 408.

[447](#)

Ibid., pp. 407-408.

[448](#)

Budge, *Amulets and Superstitions*, p. 423.

[449](#)

De Santillana and Von Dechind, *Hamlet's Mill*, p. 294.

[450](#)

Stephanie Dalley, *Myths from Mesopotamia*, p. 222, emphasis added.

[451](#)

Zechariah Sitchin, *The Wars of Gods and Men*, p. 96.

[452](#)

Ibid., p. 94.

[453](#)

Ibid.

[454](#)

Ibid., p. 239.

[455](#)

Ibid., p. 96.

[456](#)

See *The Giza Death Star*, pp. 270-271..

[457](#)

Manley P. Hall, *The Secret Teachings of All Ages*, p. 96.

[458](#)

This phrase was not italicized in *The Giza Death Star Destroyed*, but I emphasize it here.

[459](#)

Ibid., p. 160. It will be recalled that this relationship between man and cosmology was a central feature of the texts examined in *The Giza Death Star*(pp. 46-107), and that this strongly indicated that the paleophysics of the paleoancient Very High Civilization knew of, and strongly incorporated, some version of the Anthropological Principle of modern physics into its understanding of physical mechanics.

[460](#)

Joseph P. Farrell, *The Giza Death Star*, pp. 46-107.

[461](#)

Manley P. Hall, op. cit., p. 86.

[462](#)

Manley P. Hall, op. cit., p. 97.

[463](#)

Ibid., p. 306.

[464](#)

Joseph P. Farrell, *The Giza Death Star*, pp. 267-268.

[465](#)

Manley P. Hall, op. cit., p. 308.

[466](#)

In this regard it is worth noting that Hall records that in some versions of the esoteric tradition, the solar system itself becomes “Lucifer’s realm” following his fall and exile from heaven. (Hall, op. cit., p. 473)

[467](#)

Manley P. Hall, op. cit., p. 496.

[468](#)

This is precisely the contention of physicist Paul LaViolette, as will be seen later in this book.

[469](#)

Dalley, *Myths from Mesopotamia*, p. 218.

[470](#)

While many scientists do not accept the recent studies in physics concerning the “Anthropic Principle,” many do, and this principle in some form may thus be a clue as to what the science behind “makanthropos” may have been.

[471](#)

LaViolette, *The Talk of the Galaxy*, p. 132, emphasis added.

[472](#)

And the Nazi one, for readers of my book *The SS Brotherhood of the Bell* will recall the late war German radar wave-mixing experiments on their nonlinear Radar Absorbent Material. The major difference between the German experiments and the modern one is that the German radars were not *cohered*.

[473](#)

LaViolette, *The Talk of the Galaxy*, p. 132.

[474](#)

LaViolette, *The Talk of the Galaxy*, 132-134, emphasis in the original.

[475](#)

Bearden makes the following extremely disturbing remarks which provide the historical basis to LaViolette’s Mark II microwave version of this technology:

“One should also realize that the Soviets discovered time-reversed (TR) EM waves right after World War II. In the latter 60’s and early 70’s, to their astonishment, Western scientists found time-reversed EM Waves emerging in the open Soviet nonlinear optics literature. In 1972, two Soviet scientists briefed U.S. scientists at Lawrence Livermore National Laboratory on nonlinear optical phase conjugate waves.

“At the end of World War II, the Soviets discovered four-wave mixing and pumped phase conjugate mirror effects in the German radar team’s anomalous radar experiments with multibeam illumination of radar absorbing material (RAM). Specifically, in multibeam illumination of RAM materials, one gets four-wave mixing and amplified phase conjugate replica effects. The phase conjugate replica, of course, is a time-reversed EM wave. Further, in four-wave mixing, this time-reversed EM wave can be amplified. Thus anomalous, amplified, time-reversed radar waves would have been encountered in the radar team’s experiments. The Soviets obtained the entire German radar team - RAM materials, multibeam illumination anomalies and all - at the end of the war. In deciphering these anomalies, the Soviets and their German protégés discovered time-reversed EM waves, phase conjugate replicas, pumped phase conjugate mirrors, and multiwave mixing effects. And they first discovered them in *radar* waves - microwaves - not in *optical* waves.” (Bearden, *Gravitobiology*, pp. 26- 27, emphasis in the original).

As I noted, however, in my last book, *The SS Brotherhood of the Bell*, I believe that the ascription of this discovery to the Soviets by Bearden is erroneous. I believe the Germans were looking for these effects, found them, and knew full well what the physics implications were. While Bearden credits the invention of the whole vocabulary of scalar or quantum potential physics to the Soviets, since it first appears there in their open physics literature, I believe the likelihood to be that the

concepts and terms were first invented during the war by the Nazis to explain the anomalous effects they were observing in terms ideologically *acceptable* to the occult- and anti-relativistically obsessed SS that oversaw all such secret research in Nazi Germany. (Q.v. *The SS Brotherhood of the Bell*, pp. 225-229). Finally, I believe the effects of the Bell itself also involved torsion waves and interference patterns of the type outlined here. As such, it was a scalar device in every way. That the physics conceptions the Nazis were working on should so closely parallel the conceptions outlined in this chapter should give one pause.

[476](#)

Q.v. my *SS Brotherhood of the Bell*, pp. 242-248.

[477](#)

Ervin Laszlo, *Science and the Akashic Field*, p. 107.

[478](#)

Ibid., pp. 80-81.

[479](#)

Ibid., p. 55.

[480](#)

Another way of saying “linking” is “entanglement”.

[481](#)

Laszlo, *Science and the Akashic Field*, pp. 51-52, emphasis added.

[482](#)

Q.v. my *Giza Death Star Destroyed*, pp 118-122, for more information on Hartmut Mueller’s “Global Scaling Theory.”

[483](#)

Laszlo, *Science and the Akashic Field*, p. 49.

[484](#)

Ibid., p. 21.

[485](#)

Q.v. Tom Bearden, *Gravitobiology* (Testa Book Co, 1991), pp. 18, 38.

[486](#)

Tom Bearden, *Oblivion: America at the Brink* (Cheniere Press, 2005), p. 249, bold and italicized emphasis added. It is worth noting that on p. i of the book, there is the statement “This book is an expanded version of a very close-hold brief provided to a certain Head of State and his Foreign Minister in 2003.”

[487](#)

E. A. E. Reymond, *The Mythical Origins of the Egyptian Temple*, p. 18.

[488](#)

E.A.E. Reymond, *The Mythical Origin of the Egyptian Temple*, p. 6, emphasis added.

[489](#)

Ibid., pp. 91-92.

[490](#)

I should stress that what I am saying does not mean that the entire memory or consciousness of an individual is downloaded, as it were, into a “grating” or interference pattern. Rather, I mean that the generalized gratings for producing certain emotional states in a variety of individuals is what constitutes a grating.

[491](#)

Regarding “software,” the words of R.A. Boulay should once again be recalled. “In this sense they seemed to be like our modern day computer storage disks and chips. The ME were actually the how-to-manuals of the ancients but embedded in stone.

“Each ME provided the possessor full authority and power over a certain aspect of life, perhaps by providing essential information and instructions on controlling certain physical equipment. In this respect they may have been control modules use to operate certain pieces of equipment. Some of the ME were called ME-GAL-GAL or “great ME” and were associated with “divine” weapons of mass destruction.” R.A. Boulay, *Flying Serpents and Dragons*, p., 79.

[492](#)

Thorkild Jacobsen, *The Harps that Once*, p. 238.

[493](#)

Ibid., p. 239, emphasis *added*.

[494](#)

Dalley, *Myths from Mesopotamia*, p. 291.

[495](#)

Ibid., p. 292.

[496](#)

Ibid., p. 293.

[497](#)

Q.v. Dalley, p. 326

[498](#)

Bruce Rux, *Architects of the Underworld: Unriddling Atlantis, Anomalies of Mars, and the Mystery of the Sphinx* (Berkeley: Frog Ltd. 1996), p. 370.

[499](#)

Ibid., p. 305.

[500](#)

Ibid., p. 310.

[501](#)

Q.v. *The Giza Death Star Destroyed*, pp. 10-20.

[502](#)

Bruce Rux, *Architects of the Underworld*, p. 372.

[503](#)

Ibid., p. 373.

[504](#)

Ibid., p. 328.

[505](#)

Rux, *Architects of the Underworld*, p. 328, emphasis added.

[506](#)

Ibid., p. 366.

[507](#)

Rux, *Architects of the Underworld*, pp. 363-364.

[508](#)

Ibid., p. 362,

[509](#)

David Hatcher Childress, *Lost Cities of North and Central America*, p. 220.

[510](#)

Rux, *Architects of the Underworld*, pp. 362-363.

[511](#)

Ibid., p. 363.

[512](#)

Rux, *Architects of the Underworld*, p. 365.

[513](#)

Ibid.

[514](#)

In the Andes mountains of Bolivia.

[515](#)

Ibid., emphasis added.

[516](#)

Ibid.

[517](#)

Ibid.

[518](#)

Rux, *Architects of the Underworld*, p. 365.

[519](#)

Ibid.

[520](#)

Ibid., p. 364, emphasis added.

[521](#)

Rux, *Architects of the Underworld*, p. 378. Budge's translation differs slightly, saying "As to (the words) 'that night of the battle,' they concern the inroad (of the children of impotent revolt) into the eastern part of heaven, whereupon there arose a battle in haven and in all the earth." (E. A. Wallis Budge, *The Egyptian Book of the Dead: (The Papyrus of Ani) Egyptian Text Transliteration and Translation* [Dover, 1967], p. 287.)

[522](#)

The observation is actually originally Alan Alford's! Q.v. my *Giza Death Star Destroyed*, p. 28.

[523](#)

Rux, *Architects of the Underworld*, p. 366, emphasis added.

[524](#)

Rux, *Architects of the Underworld*, p., 366.

[525](#)

Ibid., p. 367.

[526](#)

Ibid., p. 369.

[527](#)

George J. Haas and William R. Saunders, *The Cydonia Codex: Reflections from Mars*, p. 5. Along with Hoagland's magnificent study of the Cydonia ruins, *The Monuments of Mars: A City on the Edge of Forever*, Haas' and Saunders' book is one of the most thought-provoking books the author has ever read. Sadly it does not get the attention it deserves.

[528](#)

Rux, *Architects of the Underworld*, p. 369.

[529](#)

Ibid., p. 370.

[530](#)

Ibid.

[531](#)

Ibid., p. 374.

[532](#)

Ibid., p. 375, emphasis in the original.

[533](#)

Note the close resemblance of the term “aker” to the Sumerian term for a pyramid, or ziggurat, “ekur”.

[534](#)

Ibid., p. 375.

[535](#)

Rux, *Architects of the Underworld*, p. 375.

[536](#)

Ibid., emphasis added.

[537](#)

Q.v. *The Giza Death Star Destroyed*, pp.

[538](#)

Rux, *Architects of the Underworld*, p. 387.

[539](#)

www.enterprisemission.com/moonl.htm. Hoagland’s pictures and his extensive commentary simply must be viewed together to obtain their full impact, and hence, no attempt beyond outlining his case is made here. The reader is urged to consult Hoagland’s paper and consider its enormous implications for the cosmic war scenario being developed here.

[540](#)

Rux, *Architects of the Underworld*, p. 391.

[541](#)

Ibid., p. 380.

[542](#)

Q.v. *my Giza Death Star Destroyed*, pp. 53-67.

[543](#)

Rux, *Architects of the Underworld*, p. 390.

[544](#)

Rux, *Architects of the Underworld*, p. 377, emphasis added.

[545](#)

Peter Goodgame, "Domination by Deception," *The Giza Discovery*, Part Six, www.redmoonrising.com/Giza/DomDec6.htm, p. 1 .

[546](#)

Cited in Peter Goodgame, "The Myth and Religion of Osiris the God," *The Giza Discovery*, www.redmoonrising.com/Giza/OsirisMyth2.htm, Part Two, p. 8.

[547](#)

Peter Goodgame, "The Saviors of the Ancient World," *The Giza Discovery*, Part Three, www.redmoonrising.com/Giza/DyingRising3.htm, pp. 13-14.

[548](#)

Peter Goodgame, "Egypt's Forgotten Origins," *The Giza Discovery*, www.redmoonrising.com/Giza/EgyptOrigins4.htm, p. 3.

[549](#)

Peter Goodgame, "Domination by Deception," *The Giza Discovery*, Part Six, pp. 1-2.

[550](#)

Ibid., p. 2.

[551](#)

Ibid., p. 3.

[552](#)

Peter Goodgame, "Domination by Deception," *The Giza Discovery*, www.redmoonrising.com/Giza/DomDec6.htm, p. 3.

[553](#)

Being personally familiar with most theological literature on this subject, this author would hardly qualify the response of theologians to this verse - from John of Damascus and Ambrose of Milan to Thomas Aquinas - as one of perplexity.

[554](#)

David Rohl, *The Lost Testament*, cited in Peter Goodgame, "Domination by Deception," *The Giza Discovery*, www.redmoonrising.com/Giza/DomDec6.htm

[555](#)

Q.v. Peter Goodgame, "Domination by Deception," *The Giza Discovery*, Part Six,

www.redmoonrising.com/Giza/DomDec6.htm, pp. 4-5.

[556](#)

Laurence Gardner, *Genesis of the Grail Kings*, p. 316. The entire set of Gardner's thorough genealogies plus his extensive annotations is found on pp. 316-358.

[557](#)

Gardner, *Genesis of the Grail Kings*, p. 317.

[558](#)

Gardner, *Genesis of the Grail Kings*, p. 319.

[559](#)

Peter Goodgame, "Domination by Deception," *The Giza Discovery*, www.redmoonrising.com/Giza/DomDec6.htm, p. 6.

[560](#)

Dalley, *Myths from Mesopotamia*, p. 326.

[561](#)

All citations in this section are from the Authorized King James version.

[562](#)

All quotations from the Bible are from the Authorized Version unless otherwise noted. Bold and italics emphasis added.

[563](#)

Cited in Peter Goodgame, "The Spirit World and Civilization," *The Giza Discovery*, p. 13, www.redmoonrising.com/Giza/SpiritCiv5.htm.

[564](#)

Ibid., p. 14.

[565](#)

Peter Goodgame, "The Spirit World and Civilization," *The Giza Discovery*, www.redmoonrising.com/Giza/SpiritCiv6.htm, p. 14.

[566](#)

Ibid., p. 15.

[567](#)

Ibid., p. 17.

[568](#)

Ibid., p. 27.

[569](#)

David Rohl, *The Lost Testament*, pp. 73-74.

[570](#)

Q.v. *The Giza Death Star Destroyed*, p. 77-78.

[571](#)

Peter Goodgame, "The Second Coming of the Antichrist," *The Giza Discovery*, Part Seven, www.redmoonrising.com/Giza/SavDest7.htm, p. 3.

[572](#)

Stephen Quayle, *Genesis 6 Giants: Master Builders of Prehistoric and Ancient Civilizations*, p. 30.

[573](#)

Q.v. Stephen Quayle, *Genesis 6 Giants*, p. 25.

[574](#)

Ibid., p. 62.

[575](#)

Stephen Quayle, *Genesis 6 Giants*, pp. 52, 53.

[576](#)

Quayle, *Genesis 6 Giants*, pp. 52-53.

[577](#)

Ibid., p. 53.

[578](#)

Q.v. my *The Giza Death Star Destroyed*, pp. 31-36.

[579](#)

Q.v. the Christian Church Father, St. John of Damascus, *On the Orthodox Faith*, or the mediaeval Latin scholastic, Thomas Aquinas, *Summa Theologica*. Other early Christian authors such as the Apologists or, even better, Origen, speculated that angels had a kind of material existence, but one that was "less dense", i.e., *closer* to the original *materia prima* from which they and the rest of creation were created. To put this metaphysical conception in slightly different, more "physics and mathematics related" terms, such beings were closer in terms of their "topological descent" from this *materia prima* than more "material" - or to use the terms of this earliest period of metaphysical speculation, more "gross" - creatures such as humans.

It is interesting to note that, in the Patristic Christian and as well as the early mediaeval Latin traditions, angels inhabit a kind of "hyperdimensional" realm, as "created everlastings," i.e., as creatures having a temporal beginning, but no end. In this sort of timeless existence, so closely tied to the transmutative aether, there is no distinction between an act of the will and the formation of its habit, a condition that *does* apply to humans. Thus, angels, on this view, acquire a habit or "impressed dynamic" simultaneously with the first exercise of their will, for good or ill. Extending this line of reasoning, this impressed dynamic conceivably impresses itself in turn on objects that they encounter.

[580](#)

David Cohen, "Plasma Blobs Hint at New Form of Life," *New Scientist*, 17 September, 2003.

[581](#)

Another obvious implication of such a life form would be that it would be capable of inhabiting worlds not thought to be habitable by human-like life.

[582](#)

Q.v. Revelations 12:7.

[583](#)

R.A. Boulay, *Flying Serpents and Dragons*, p. 41.

[584](#)

R.A. Boulay, *Flying Serpents and Dragons*, p. 41.

[585](#)

From R. A. Boulay's *Flying Serpents and Dragons*, p. 44.

[586](#)

Ibid., p. 45.

[587](#)

R.A. Boulay, *Flying Serpents and Dragons*, p. 44. Note, in the second of the above pictographs, the three stars above the snake which appear to be the three stars of the belt in the constellation Orion.

[588](#)

Ibid.

[589](#)

R.A. Boulay, *Flying Serpents and Dragons*, p. 47.

[590](#)

Ibid., p. 52.

[591](#)

Isaac Asimov, *Intelligent Man's Guide to Science*, p. 108.

[592](#)

Don Wilson, *Our Mysterious Spaceship Moon*, p. 72,

[593](#)

Don Wilson, *Our Mysterious Spaceship Moon*, pp. 26-27.

[594](#)

Ibid., p. 24.

[595](#)

Vostok was a Russian lunar landing probe.

[596](#)

Don Wilson, *Our Mysterious Spaceship Moon*, pp. 58-59.

[597](#)

In my opinion, this is simply an error in transcription, since “steep ridge” could sound like “steep bridge.”

[598](#)

EVA, that is, extra-vehicular activity.

[599](#)

Don Wilson, *Our Mysterious Spaceship Moon*, pp. 135-136.

[600](#)

Ibid., p. 145.

[601](#)

Don Wilson, *Secrets of Our Spaceship Moon*, p. 53.

[602](#)

Q.v. my *SS Brotherhood of the Bell*, pp. 54-137.

[603](#)

Don Wilson, *Secrets of Our Spaceship Moon*, p. 261.

[604](#)

William L. Brian II, *Moongate: Suppressed Findings of the U.S. Space Program*, p. 63.

[605](#)

See also my previous book, *The SS Brotherhood of the Bell*, pp. 123-128.

[606](#)

For further discussion of this point, see my previous book, *The Giza Death Star Destroyed*, pp. 8-9.

[607](#)

Don Wilson, *Our Mysterious Spaceship Moon*, p. 21.

[608](#)

Daniel Ross, *UFO's and the Complete Evidence from Space: The Truth about Venus, Mars, and the Moon*, p. 100.

[609](#)

David Hatcher Childress, *Extraterrestrial Archeology*, p. 80, citing NASA's “Lunar Orbital Science

Visual Observation Site Graphics, Apollo Mission 15, for V-4, Cauchy Rilles region (38.7° E, 9.7° N). Childress' book is full of photographs of these strange "domes" which are almost perfectly circular objects, often found in the bottom and exact center of smaller craters.

[610](#)

Daniel Ross, *UFO's and the Complete Evidence from Space*, p. 101.

[611](#)

Ibid., p. 102.

[612](#)

Daniel Ross, *UFOs and the Complete Evidence from Space*, p. 103, emphasis in the original.

[613](#)

Don Wilson, *Our Mysterious Spaceship Moon*, pp. 66-67.

[614](#)

Ibid., p. 79.

[615](#)

Don Wilson, *Our Mysterious Spaceship Moon*, p. 99.

[616](#)

Ibid.

[617](#)

Ibid.

[618](#)

Don Wilson, *Our Mysterious Spaceship Moon*, pp. 101-102, citing *Popular Science*, January, 1972, pp.67-68.

[619](#)

Ibid., pp. 105-106.

[620](#)

Ibid., p. p. 125.

[621](#)

Don Wilson, *Our Mysterious Spaceship Moon*, p. 95.

[622](#)

Ibid., p.49.

[623](#)

Ibid.

[624](#)

Ibid., p. 50.

[625](#)

Daniel Ross, *UFOs and the Complete Evidence from Space*, p. 130.

[626](#)

Richard C. Hoagland, *The Monuments of Mars: A City on the Edge of Forever*, Fifth edition, p. 149.

[627](#)

Richard C. Hoagland, *The Monuments of Mars: A City on the Edge of Forever*, fifth edition, pp. 112-113.

[628](#)

See his discussion on pp. 114-117.

[629](#)

Hoagland, *The Monuments of Mars*, p. 126.

[630](#)

Richard C. Hoagland, *The Monuments of Mars*, p. 148.

[631](#)

Hoagland, *The Monuments of Mars*, pp. 148-149, all emphasis Hoagland's.

[632](#)

Thorkild Jacobsen, trans and ed., "The Lugal-e," in *The Harps That Once...*, p. 237.

[633](#)

Ibid., p. 245, emphasis added.

[634](#)

Mars' other little satellite is named Deimos, or "Trembling."

[635](#)

Cited in my *The Giza Death Star Destroyed*, p. 54.

[636](#)

Hoagland, *The Monuments of Mars*, p. 350, emphasis Hoagland's.

[637](#)

Ibid.

[638](#)

It should be noted that Hoagland is certainly aware of the work of Sitchin. And it should also be pointed out that Hoagland has, on some occasions during radio talk show interviews, alluded to the

possibility of a war having been the cause of the destruction of Mars and of the former planet that caused the asteroid belt.

[639](#)

Richard C. Hoagland, *A Moon with a View: Or, What Did Arthur Know...and When Did He Know It?* Part 4, p. 2, www.enterprisemission.com/moon4.htm.

[640](#)

Ibid., Part 1, p. 6, www.enterprisemission.com/moon1.htm.

[641](#)

Hoagland, *A Moon With A View*, Part One, p., 7, www.enterprisemission.com/moon1.htm.

[642](#)

Hoagland, *A Moon With A View*. Part One. p. 8, www.enterprisemission.com/moon1.htm.

[643](#)

Hoagland, *A Moon With A View*, Part Four, pp. 22-23, www.enterprisemission.com/moon4.htm, emphasis Hoagland's.

[644](#)

Ibid., p. 23.

[645](#)

Hoagland, *A Moon With A View*, p. 23, bold and italicized emphasis added, www.enterprisemission.com/moon4.htm.

[646](#)

Ibid., p. 24, emphasis Hoagland's.

[647](#)

Hoagland, *A Moon With A View*, www.enterprisemission.com/moon1.htm p. 9,

[648](#)

Hoagland, *A Moon With A View*, Part Two, pp. 10-11, www.enterprisemission.com/moon2.htm.

[649](#)

Hoagland, *A Moon With A View*, Part Two, p. 11, www.enterprisemission.com/moon2.htm.

[650](#)

Hoagland, *A Moon With A View*, Part 1, p. 21, emphasis Hoagland's, www.enterprisemission.com/moon1.htm.

[651](#)

Ibid., p. 22, emphasis Hoagland's.

[652](#)

Ibid., Part 2, p. 26.

[653](#)

Hoagland, *A Moon With A View*, Part 2, p. 26, emphasis Hoagland's, www.enterprisemission.com/moon2.htm.

[654](#)

Ibid.

[655](#)

Ibid., p. 27, emphasis Hoagland's.

[656](#)

Hoagland, *A Moon With A View*, Part 6, p. 2, www.enterprisemission.com/moon6.htm.

[657](#)

Ibid., p. 3. It should be pointed out that our survey here has barely scratched the surface of the detailed analysis that Hoagland gives to this precise point.

[658](#)

Ibid., p. 5, emphasis Hoagland's. Again, space did not permit us to explore this aspect of Hoagland's analysis. But the point he is making is obviously related to the fact that lapetus displays flat, planar edges.

[659](#)

Hoagland, *A Moon With A View*, Part 6, p. 8, emphasis Hoagland's, www.enterprisemission.com/moon6.htm.

[660](#)

See my *The Giza Death Star Deployed*, pp. 1-11.

[661](#)

Hoagland, *A Moon With A View*, Part 6, p. 8, emphasis Hoagland's, www.enterprisemission.com/moon6.htm.

[662](#)

Ibid., p. 14.

[663](#)

Michael A. Cremo, from the Introduction to Michael A. Cremo and Richard L. Thompson, *The Hidden History of the Human Race*, p. xix.

[664](#)

Michael A. Cremo, from the Introduction to *Forbidden Archeology*, p. xxiv.

[665](#)

Cremo and Thompson, *Forbidden History*, p. 19.

[666](#)

Cremo and Thompson, *Forbidden Archeology*, p. 19.

[667](#)

Cremo and Thompson, *Forbidden Archeology*, p. 22.

[668](#)

Cremo and Thompson, *The Hidden History of the Human Race*, p. 103.

[669](#)

Cremo and Thompson, *The Hidden History of the Human Race*, p. 104. ⁸ Ibid., p. 105.

[670](#)

Cited in Cremo and Thompson, *The Hidden History of the Human Race*, pp. 106-107.

[671](#)

Cremo and Thompson, *The Hidden History of the Human Race*, p. 107, emphasis added.

[672](#)

I stress this point simply because mere suppression of anomalies such as this cannot advance the cause of science. They should be presented to the scientific public for its consideration, not rejected by editorial committees with a vested interest, often financial, in maintaining a status quo.

[673](#)

Cremo and Thompson, *The Hidden History of the Human Race*, p. 109.

[674](#)

Ibid.

[675](#)

Ibid., p. 110.

[676](#)

Ibid.

[677](#)

Ibid., p. 109.

[678](#)

Cremo and Thompson, *The Hidden History of the Human Race*, p. 113.

[679](#)

Ibid., p. 114.

[680](#)

Cremo and Thompson, *The Hidden History of the Human Race*, p. 115.

[681](#)

Ibid.

[682](#)

For a review, see Cremo and Thompson's discussion on pp. 118 -120.

[683](#)

Crema and Thompson, *The Hidden History of the Human Race*, p. 120.

[684](#)

Ibid., p. 119.

[685](#)

Crema and Thompson, *The Hidden History of the Human Race*, p. 121.

[686](#)

Ibid., p. 117.

[687](#)

Ibid., p. 121.

[688](#)

Richard C. Hoagland, *A Moon With A View*, Part 6, p. 19, www.enterprisemission.com/moon6.htm.

[689](#)

See my *Reich of the Black Sun*, pp. 287-295.

[690](#)

The struck through portion is in the original document.

[691](#)

Cited in my *Reich of the Black Sun*, p. 295.

[692](#)

E.A. Wallis Budge, *The Egyptian Book of the Dead: (The Papyrus of Ani), Egyptian Text Transliteration and Translation*, (Dover), p. 287.

[693](#)

The Giza Death Star, p. 31, citing William Henry, *One Foot in Atlantis: The Secret Occult History of World War II and Its Impact on New Age Politics* (Anchorage, Alaska: Earthpulse, 1998), p. 7.