

# **THE BOOK OF ULTIMATE WISDOM**

**By Team O°chelle**

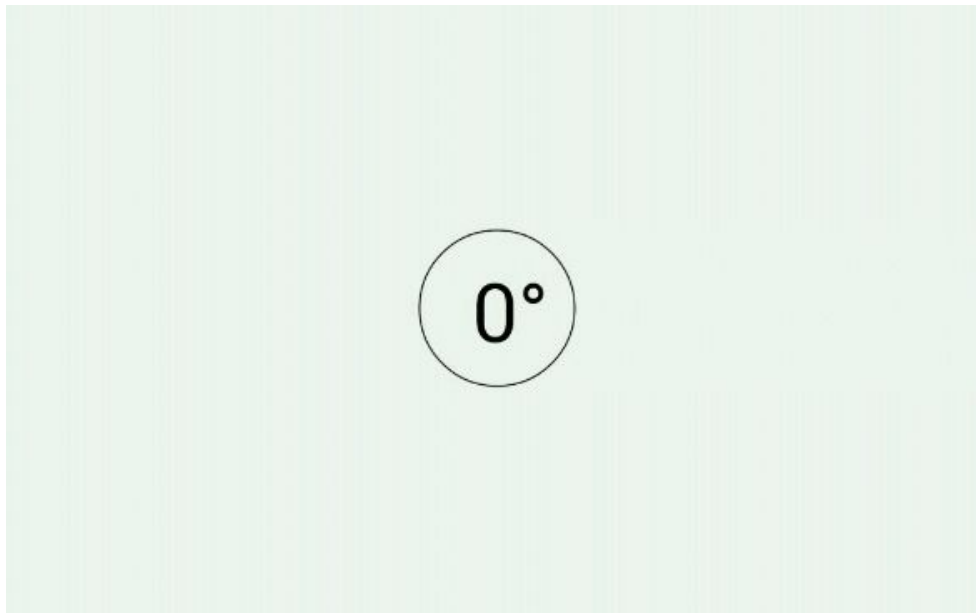

**An Introduction to Divine and Supra-Divine Wisdom**

## Introduction

This is an Original; not a copy! This Book of Ultimate Wisdom draws directly from super-human sources that the world claims to be 'Divine'. Fact is that 'human' is a relative expression and so is 'divine'. Human and Divine are mirror pictures of each other projected out of a third that is still largely unknown and unheard of on Earth.

If we call the mirror picture to the human 'divine', then what will we call the 'third' that is effectively 'projecting' both human and divine in a dual presentation.

One ultimately needs the viewing perspective of that Unknown Third; only then one will see in all clarity and finally understand. This Book of Ultimate Wisdom is written as seen out of that perspective; things are not derived from the human world. That is why we call this book an Original. It is not derived from human publications or presentations whatsoever. It is a first hand view out of a perspective that is still unknown to most human beings.

If we were sitting on top of a tree among small branches and plenty of leaves, we would find it difficult to analyse the nature of that tree. We are simply too close to things and would likely come to incorrect conclusions. One would, ideally, climb down from that tree and walk a few steps away. Now we can see that tree in all its beauty and we will be able to talk about that tree. The tree consists, inherently, of three parts: We see the greenery above ground and if we dig down we would find roots below the ground. But there is a third that gave raise and birth to the tree. That's the seed from which that tree has grown. To fully understand that tree we would have to start with that seed that projected dual into a part going upwards and a part striving downwards. Similarly it is with the human and divine sides that have come out of the Third. In the case of that tree the Third was the seed. We need to understand that 'third' to be able to correctly analyze the two projections that came out of it.

This Book of Ultimate Wisdom is presenting out of that Third Angle perspective. Such perspective, unknown to most human beings, may sometimes be a cause of confusion on the human side: The projected. We have been trying to bridge that gap between 'projection and projected' by frequently switching viewing angles. There are three viewing angles involved.

Traditionally, people have been held to 'worship' rather than to investigate. That approach made it easier for earthly rulers to keep control. Belief in given concepts was encouraged, often even enforced. Investigation, especially investigation on one's own, was strongly discouraged. As such much existing information, declared as 'heresy', was lost to the human world. Religion became a matter of ritual and blind belief. 'Religion is opium to the people', it was eventually claimed; and sure it was and still is. But religion is not meant to be a drug. It is meant to be a clarification of matters that are based on scientific facts. Religion is meant to explain and teach scientific facts to the masses that may not even be able to read and write. But rather than making people knowledgeable, giving them wisdom, for centuries and millennia they were given a drug called religion. Can we then call anyone a drug addict, because such person has experienced religion only as such?

It is time to clarify things to the masses. That is why this Book of Ultimate Wisdom was prepared. It will be the duty of clergy and religion to administer these facts in small doses; an antidote to the opium that was administered for centuries and millennia. De-drugging the masses will take time; we envisage a time frame of some 500 solar years. The world in the 26th Christian Century then will be a much wiser one.

This Book of Ultimate Wisdom is divided into three parts. Part 1 deals with basic knowledge and information in twelve chapters focusing specifically on the two projected sides: The Human and the Divine.

Part 2 of this Book of Ultimate Wisdom will largely be of scientific nature explaining the 'three sides or viewing angles' from an earthly understandable scientific perspective.

Part 3 of this Book of Ultimate Wisdom is called 'Wisdom in Action'.

Science in itself is a theory as long as it is not put to practice. Such practice is a personal one and no one can teach that. Each and every individual will need to make its own experience and derive its own self-realisation. Such experiences may differ, as people differ in nature and upbringing. The tree came from the SEED. That's the common start for all; the rest of the development is an individual one in a way that no two trees naturally grow exactly the same. Individuality is everything! Individual experience is therefore the most important, as no one wholly and totally can speak for the other. Individuals may write volumes of books about their own paths and developments. These are mere individual expressions and experiences and not pertain to anyone else in the exactly same fashion. One could study such works for general idea and information, but then one has to set out to explore and experience oneself and write perhaps one's own volume of books. That's the part where an outsider like clergy

and religious authorities can't really help anymore. Once the child has grown up the parents will have to let their child go and explore on its own. It's the same when it comes to religion; would all religious bodies please take note of that and not stop people or even force 'religiously grown ups' down to their own level of knowledge and understanding. Everyone will eventually need to proceed on its own and new ones to be taught the basics will come to keep the clergy engaged and busy. That is the true role of the clergy of this world and not to forcefully hold its members in smaller and larger flocks forever.

We will now proceed in Part 1 with acquainting the human world with some basic facts about their very own existence on Earth. To wholly understand that, one would have to take the 'third' viewing angle oneself. As this is initially impossible for the typical human being, we would like to suggest 'openness' and 'receptivity' to humanly new thoughts and ideas. In the finals, when each individual gathers its own practical experiences, everything will be clearly understood; scientifically and not merely religiously.

This 'Book of Ultimate Wisdom' is 'An Offering to a much bewildered World' that not even understands its own existence here on Earth beyond religions of unproven belief concepts. This offering is rendered 'free of cost' and no 'donations' are being called for. The divine side serves free; a striking difference to the human world that largely works for monetary gain.

We suggest that no changes are being made to this Offering, neither contextually nor grammatically. We understand that scholars strive for perfection of presentation; we rather strive for perfection of contents and information and don't worry then, when there are occasional spelling errors and grammatical mistakes in the text. Please take the text 'as is' and refrain from so-called 'interpretation'. Ultimate truth and facts of this Universe don't need an interpretation; they are clear in themselves once one has mastered the three viewing angles involved. Till such mastery is achieved, please take statements as information that will become clear at a later stage instead of trying, in desperation of understanding things theoretically, to interpret and put some human sense in what has been said in this 'Book of Ultimate Wisdom'. Your practical experience is of utmost importance to such understanding. Things are about 'self-realisation' and not intellectual memorization. The one that has really understood can speak; the one who just memorised is inherently not much different from a parrot that recites but doesn't understand the meaning of its recitation. Please develop yourself into a knower of things; not become a parrot or blind believer of statements whatsoever. You need to put things to the test within the framework of your own daily life, no matter where you are and what you represent in your community. You don't need to be a scholar or university laureate to be a person of great wisdom. Wisdom is inborn in each and every human being; one just has to bring it out.

## **Table of Contents**

### **Introduction and Table of Contents**

### **Part I - Comprehensive Knowledge and Understanding**

**I.1.1 In the Beginning**

**I.1.2 Creation**

**I.1.3 Before the Beginning**

**I.1.4 Creation re-addressed**

**Note How to read and study this offering?**

**I.2.1 Relative versus Absolute, Circular versus Linear**

**I.2.2 We are running in Circles, aren't we?**

**I.2.3 Is there something like a 'Creator'?**

**I.2.4 A most lovely entertaining Computer World**

**I.2.5 The Universe WE live in**

**Note The Eager Researcher**

**I.3.0 The Creator and the Creators**

**I.3.1 Joint Venture Operations and Team Work**

**I.3.2 Key Differences between Gods and Humans**

**I.3.3 Selective versus Universal**

**Note The impossible feat of being multi-gender**

**I.4.0 The Role of Clergy and Religion**

**I.4.1 What is the Role of Religion?**

**I.4.2 The role of the Clergy****Note Why study the Book of Ultimate Wisdom?****I.5.0 The Queen of the Amazons****I.5.1 Human and Divine Outlooks****I.5.2 Hermaphrodite - a Clue to Ultimate Wisdom****I.5.3 Ages of Wisdom and Ages of Ignorance****I.5.4 The Clues left behind for us from Higher Ages****Note The Secret of the Universe revealed****I.6.0 "Hurrah, I'm a God; let's go out and have fun!"****I.6.1 Striking Qualities of a True God of the Micro Cosmos****I.6.2 Why do we suffer here on Earth?****I.6.3 "We don't need to be a God"****Note You ask for proof, you say ...****I.7.1 We shall be forgiven; so why worry?****I.7.2 Eternal life in Heaven is awaiting us****I.7.3 I am an Expert; trust me!****Note Of Divine Origin****I.8.0 I am a Soul****I.8.1 Soul, Mind and Body****I.8.2 Reincarnation as it unfolds****I.8.3 We come with nothing, we go with nothing****I.8.4 Is the Universe our Home?****Note A world beyond our Universe?**

**I.9.0 Not knowing what 'they' do...****I.9.1 The Realities of Life****I.9.2 Russian Roulette****I.9.3 Belief, Trust, Faith****Note Faith****I.10.0 What is in it for ME?****I.10.1 I am God****I.10.2 Relative versus Absolute****I.10.3 Need help?****I.10.4 I believe in my 'Savior'!****I.10.5 I have 'my Guru'!****I.11.1 Ignorance leads to Confusion****I.11.2 Confusions of Mind****I.11.3 The best Citizen in the best Form of State****I.11.4 Who's the Owner anyway?****Note The Purpose of Life****I.12.0 Reward and Punishment****I.12.1 What is Balance?****I.12.2 The Balance of the Universe****I.12.3 The Effects of Imbalancing the World around us****I.12.4 The Need for Greed****Note Divine Logic versus Human Logic**

## **Part II - Scientific Insights**

**II.1.0 The Secret of the Legendary Philosopher's Stone**

**II.2.0 Scientific Analysis**

**II.3.0 Further Scientific Considerations**

**II.4.0 Advanced Scientific Considerations**

**II.5.0 Universal Aspects**

**II.5.1 The Area or Region around Start and End**

**II.5.2 The Third Side**

**II.5.3 Our Universe Unveiled**

**II.5.4 The Third Angle called Zore**

**II.6.1 A small Analysis of our Universe**

**II.6.2 We got into the Circle; how to escape it again?**

**II.6.3 Introduction to Part III of this Book of Ultimate Wisdom**



## **Part III - Divine and Supra-Divine Insights**

### **III.1.0 The Relative Nothing and the Relative Everything**

#### **III.1.1 Beyond 'Zero and Infinite'**

#### **III.1.2 The 'Switch' from Human to Divine Perspective**

#### **III.1.3 Our Universe as seen out of the Supra-Divine Perspective**

#### **III.1.4 The real Us or Me**

#### **Note The World outside the Big Show**

### **III.2.0 The World around us (seen from the Supra-Divine Angle)**

#### **III.2.1 Mind and Body**

#### **III.2.2 Sense Experience**

#### **III.2.3 Sustenance**

#### **III.2.4 A look at the health scenario from the supra-divine angle**

#### **III.2.5 Healing through GENTLY stimulating MIND**

### **III.3.0 The Nature of Mind**

#### **III.4.1 Methods of Healing**

#### **III.4.2 The Nature of Action and Consequence**

#### **III.4.3 The Law of Cause and Effect**

#### **III.4.4 In all fairness and where it starts there it must end**

### **III.5.0 Close to Zero and Infinite**

#### **III.5.1 The Operator Perspective**

#### **III.5.2 Back at the Controls**

#### **III.5.3 Helping Others**

**III.5.4 Helping effectively**

**III.5.5 Mental Healing using Mass and Energy**

**III.6.0 Implications**

**III.6.1 Our own choice**

**III.6.2 Communications with Mind**

**III.7.1 Who am I ?**

**III.7.2 Enlightenment**

**III.7.3 Up to the Challenge?**

**III.7.4 Beyond Mind**

**III.7.5 Obstacles**

**III.7.6 In Daily Life**

**III.7.7 Involve your Partner**

**III.7.8 Taking Rest**

**III.7.9 What is in it for 'Me'?**

**III.7.10 The Ultimate God**

**III.8.0 To Be or Not To Be**

**Epilogue**

**Authors' Note**

# PART I

## I.1.1 In the Beginning

In the Beginning there was a VOID. We could call this VOID a Nothing, but the word Nothing is an expression in relation to Everything. The VOID was neither Everything nor Nothing nor did it have existence. Existence is relative to Non-Existence. That VOID was not relative to something else; nor was it absolute. Why? Simply because Absolute is the one and Relative the other. That VOID was neither the one nor the other.

This VOID can't be called GOD, as GOD is relative. One might want to claim here that by human understanding GOD is absolute. But that's only human understanding that can claim that in relation to its own relative existence here on Earth.

An illustration might help here. Let's say someone was born on Earth in what people would call a royal family. However, the last person that was the King was the Great Grandfather. Can that person of the present generation still claim to be a King. One is a King relative to a country that accepts that person as their King, isn't one?

A GOD can only be GOD in relation to something that is not GOD, like a King can only be King in relation to something that is not King. When no 'something else in relation to...' exists, then how could one make any relative claims. Again, as human beings we might now claim again that then we talk about something Absolute.

We see we are running in a circle trying to explain VOID. And that is what EXISTENCE ultimately is all about: Running in endless circles, over and over again, more or less repetitive. VOID was there before there was EXISTENCE - and VOID isn't NON EXISTENCE either. We need to break out of 'that vicious circle' of our own thinking, if we want to logically understand VOID.

Let us draw a simple circle on a piece of paper. The point, where we start our drawing from, we say is Point ZERO. Then we draw the circle towards INFINITE. Where is Point INFINITE. Point Infinite is the place where we close our circle and lift our pen off the paper. Illogical? How could the Infinite be a defined point: The rear side of Point Zero, where we started our circle drawing from, being Point Infinite, as that is where the circle drawing ended?

We could help our consideration in saying that the diameter of the circle could be Infinite, as we did not define a diameter in this example. Different people would quite likely have drawn circles in different sizes, wouldn't they. But, where it started there it ends. In a circle like the

one we just drew up the farthest point from where we started the drawing is the end point where the circle closes and we lift our pen off the paper. The farthest possible point is defined as Infinite. Would we just have drawn a straight line, Point Infinite could not have been shown. But in a circle like the one we just drew up Point Zero is the same point as Point Infinite. We could just say, to help our little consideration, that Point Infinite is on the Rear Side of Point Zero.

It is that 'vicious circle' of our own thinking that we must escape from to understand VOID.

## I.1.2 Creation

Let us now place our just drawn circle into the discussed VOID. We can now distinguish three participants in our concept-model:

- (1) The VOID that we started our consideration from, non related and non absolute without anything to refer to or compare with.
- (2) The Circle that we drew on a piece of paper for more clarity and understanding and now put it into a context in making it a concept-model for us.
- (3) A new VOID that is relative to the Circle that we introduced and perhaps absolute in itself. Our Circle is said to be "floating" in a VOID.

Here we have to make an amendment to our consideration in determining that we need a new word to express VOID as shown in (1), as it is different from VOID as shown in (3). We simply switch the center letters 'o' and 'i' to coin a new word. VIOD is the word that we will be using from here on whenever we speak of the VOID as discussed in (1) above.

In our consideration we started from what we call now a VIOD and 'created' a 'something' consisting of Circle and VOID. Circle and VOID are relative to each other as they 'exist' in each other. VOID has 'existence' in relation to the Circle we placed in it and the Circle exists in relation to VOID. Remember, VIOD had no existence, as there was nothing to compare that with nor was VIOD existence absolute.

However, with the introduction of the VOID and Circle consideration even our term VIOD has now become relative to both VOID and Circle equally, as we started the development out of what we now call VIOD. We could just say that VIOD was the foundation that set 'the ball rolling' to arrive at a VOID and Circle Consideration. In other words we could also say that we projected VOID and Circle out of VIOD, couldn't we?

### **I.1.3 Before the Beginning**

'Before the Beginning' sounds illogical. The human folks typically think 'absolute' and so there could not have been anything BEFORE the beginning. But if we approach the subject 'relative', then there could have been something BEFORE the beginning.

Let's fill a bowl with water. Before, the bowl was empty; we also could say it was 'filled with void'. After putting the water inside the bowl, the water floats 'inside the void'.

BEFORE the beginning there was consciousness floating in the VOID that we later determined as VIOD.

When the water inside the bowl has come to rest there is no movement whatsoever. Consciousness rests in the Viod likewise. But there is a POTENTIAL to change. If we move the bowl the water inside the bowl moves too. Likewise the consciousness floating in the VIOD has POTENTIAL too.

Consciousness can be both active and passive, expressed and unexpressed.

### **I.1.4 Creation re-addressed**

Consciousness is both passive and active. It can remain and it can change itself as well as effect change. Consciousness is a bit like dow that children play with. In this context it resembles water that can take on almost any form as well as change itself into ice and vapour. Water can perform labor if channeled accordingly. So can consciousness.

Let us have a look at a lovely lake on a calm day without any wind. The surface of the lake is flat like a mirror and quite likely we can see our reflection in it. Now wind comes up; our reflection distorts. Little wavelets form on the surface of the water. The wind increases in intensity; a storm comes up and huge waves are moving around the surface of the lake. The storm calms down and the wind subsides. Again we can see our mirror reflection in the calm surface of the water inside that lake.

One might want to ask WHAT has changed OVERALL after so much activity on the surface of that lake. There was a lot of 'change' to be observed, but all that change was relative and

compensated back into Zero. Thus, overall there was NO CHANGE. The lake was after the storm exactly the same as before the storm.

Likewise is consciousness. It transforms, it changes, it expresses - there is a lot of activity and change - but all that is relative and compensates to 'no change' overall.

That's the world and universe we live in.

### **How to read or study this offering?**

This is the Book of Ultimate Wisdom. Ultimate Wisdom has no price and if it had, the price would be way beyond human imagination. Thus is the value of ultimate wisdom.

This is an OFFERING to a much bewildered world that can't understand its own existence here on Earth. Religions are mere unproven belief concepts. While each of the many religions CLAIM to be Ultimate Truth, all those religions are based on CONCEPTS that someone had formulated in distant times. There is, alas, no proof. So one is held to BELIEVE.

This Book of Ultimate Wisdom introduces thoughts, ideas and concepts that may be NEW to the people of this world. People may feel confused. What are those thoughts, ideas and concepts that are presented here and where do they originate from?

It is and has been customary to give REFERENCES for new write-ups of this kind; but references have been omitted here on purpose. There are just too many references to the said in this Offering. The diligent reader is encouraged to investigate further and find those references. Only then things will become clear. Spoon-feeding anyone with Ultimate Truth is NOT the Objective of this Offering. Ultimate Truth must be mentally assimilated and mentally digested, then further researched to be understood. This research is the duty of each individual, irrespective of its scholastic education and standing in society.

Understanding one's own existence on Earth is a job that can't be delegated. For millenniums so called 'clergy' has made it their business to INTERPRETE 'Holy Scriptures' and other texts for the masses. Why is there a need to interpret? Most scriptures are very clear in their sayings. Is it perhaps that people generally don't like everything that the scriptures say and proclaim? Are customs and traditions of ageless societies more important to the masses than Ultimate Truth pertaining to one's existence here on Earth? Could it be, perhaps, that clergy of all kind set out to interpret 'Holy Scripture' to the masses in ways that are pleasant to their

ears and expectations or simply to foster the clergy's own motives? Sure, clergy members want to live too. Could clergy risk being left to starve by their individual congregations, if they 'interpret' scripture in ways that are not pleasant to the ears of the people, not confirming people in pre-conceived ideas of culture, customs and traditions, etc.?

The need for 'Interpretation' clearly shows that people either don't understand or simply 'don't want to' understand. Otherwise texts could be taken 'as is' without further interpretation. It is interesting to see in how many different ways existing Holy Scriptures have been differently interpreted by the various sects and groupings within a particular religion.

How are things with this Offering of Ultimate Wisdom? Is there a need for 'interpretation' too?

Clearly speaking, there should not be a need for 'interpretation' of any kind, as we have tried to show things in their ultimate simplicity. The foundations of this Universe and the root cause of human existence are extremely simple. What is baffling, though, is the COMPLEXITY that can be developed out of such SIMPLICITY. If we start with Complexity, yes, then it will be very, very difficult to understand. But if we start from the Simplicity, things will be easy even when further developed into Complexity. We must not start with 'us', as we are an expression of that Complexity, but we must start from what was there before we even existed. Only then we will be able to understand our own existence here on Earth.

So we have started with the 'origins' overthrowing existing human ideas like God being an 'absolute being'. Another change needed is our mind setting. We are living in a world of relativity, but approach things usually absolute. When even God is relative, then why do we cling to our cherished absolute thinking? Once we drop our love for things being 'absolute' and switch over to RELATIVE THINKING so many facts of life will start making sense.

We sure did not understand the Introduction to the Origins of this world as outlined in the beginning of this chapter. Ideas and concepts like VOID and VIOD escape our mental frame work, don't they? Then what will we do now? Start once again with interpreting? Please don't!

Rather than interpreting let's put thoughts we can't understand temporarily aside. We can deal with them later. This Offering may need to be read in the reverse, per chance; starting to read things with the last chapter first. Or we may need to switch in and out repeatedly; reading a part in the beginning, followed by the last chapter and then again in the middle. It all depends on our present frame of mind. There is no scholastic approach taken here. Ultimate Truth is 'circular' and 'relative' in nature; not a straight line starting from Zero and ending in Infinite.



One can walk a circle clockwise and counterclockwise, can't one? Thus it is also with this Offering of Ultimate Truth. There is no 'best way' or 'fastest way', but many 'relative ways'. That 'relative' pertains to us and our present frame of mind. Different people likely will read this Offering in different ways; it is up to us individually to find the 'relative approach' that suits us best. No 'clergy' or 'scholar' is needed for that; we are asked to investigate ourselves, each one of us with their individual relative approach.

This is the Book of Ultimate Wisdom, an Offering to a much bewildered world, priceless in value and therefore given free. But investigation of a personal kind remains a necessity. No references are given; it is up to the reader and student to find those references themselves. Thorough investigation of the personal kind will reveal those references to the eager reader and student delivering the proof and confirmation of the things being said here being true. But no confirmation will be found by the one looking for references in this Offering itself; perhaps the kind of person accustomed to be 'spoon-fed' with the details. In this respect this Offering is unique among so many Presentations.

This Presentation is an Offering of Ultimate Truth to a much bewildered world that does not even understand its own existence in this Universe: An Original, not a Copy!

So take your time to acquaint yourself with Ultimate Wisdom the way it presents itself everywhere in the Universe: To be seen by those who know HOW to see and to be heard by those who know HOW to hear and to be smelled by those who know HOW to smell and to be touched by those who know HOW to touch and to be tasted by those who know HOW to taste; for five senses are available to us.

## **I.2.1 Relative versus Absolute, Circular versus Linear**

We live within the boundaries of a Universe that is RELATIVE in its inherent nature. The processes and movements within this Universe are CIRCULAR and not linear, even though it may sometimes look otherwise.

Speaking of 'boundaries' suggests that there is something beyond or outside this Universe; but this is just logical speculation at this stage. Let's consider that our Universe is a huge bubble that hangs, swims or floats within a VOID like water hangs, swims or floats within the empty space of a CUP. Everything that 'happens' happens within this boundary. As all processes and movements are inherently circular and not linear, it is not difficult to imagine that everything 'rotates' within the 'bubble' that we call our Universe.

In a Circle we start at some point that we may call 'Point Zero'. Then we draw a circle clockwise or counterclockwise till we reach the point where we started. That's the place where we lift our pen off the paper. The maximum distance from Point Zero from where we started to draw is 'Point Infinite'; simply because in a circle that's the largest distance from 'Point Zero' possible. Interestingly, in a circle Point Infinite and Point Zero are in the same place and location. One could say that the reverse side of the marker that we could have used to write 'Point Zero' on when we started to draw is marked with 'Point Infinite'. While in movement on the circle we would, looking back to where we started, see our marker with a big ZERO written upon it and not realize yet that the reverse side of just that marker shows INFINITE.

What makes that distance around the circle INFINITE when it is a clearly identifiable spot that is located just behind the Zero? It is the diameter of the circle that we did not specify. We may realize here that within the boundaries of that 'bubble' that we call our Universe that 'Infinity' must be relative and not absolute. Our Universe is immensely 'huge', so that we could speak of 'relative infinity', but there is no such thing as 'absolute infinity', as we may realize now. In our discussed circle 'relative infinity' depends on the not specified diameter of our circle. Infinity, not specified distance or vastness, is relative.

## **I.2.2 We are running in Circles, aren't we?**

Our Universe, though huge, is ultimately a 'bubble' that hangs, swims or floats in a non-specified VOID in a similar way as water may hang, swim or float within the empty space of

a cup. Awesome or frightening?

Infinity is 'relative' and not absolute. And all processes and movements are circular, too. Then what about us who are living within this Universe and its circular planetary movements? Are we relative, too? Relative to what, if we may ask? And are we running 'in circles', too, perhaps without knowing it?

### **I.2.3 Is there something like a 'Creator'?**

If we would be the Creators of a Universe similar to ours ourselves, how would we proceed? We could, for example, 'create a Universe' in our computer, couldn't we?

Then how would we go about that?

In the 'Beginning' there is a smart and clever computer software writer. That software writer may program his/her own ideas and perceptions or the ideas and perception of someone else. Whichever of these two options, one would sit down, first, and discuss 'in principle', how this 'Universe' is supposed to look like and how it is going to function. One could take a linear approach in which the Universe 'starts' at some point of time and then 'ends' at some point of time. One also could take a circular approach, in which our Universe, once set in motion, keeps running 'in a circular pattern' on and on and on till someone takes the action to stop it again.

Of course, in a circular pattern the processes of our Universe repeat after some time, again and again, and things could get 'boring'. But one could also envisage a circular Universe similar like an old good mechanical clock, that runs on many small wheels that move the time indicators. One round of the long indicator that we call 'an hour' moves the short indicator by a distance that we usually call 5 minutes. The long indicator then repeats the same circle as before, but due to the changed position of the short indicator we speak of 'different time'.

Let's create a circular Universe in a circular pattern like a mechanical clock, as that promises to be fun. We could call the time frame of one round of the long indicator 12,000 solar years and the time frame of one full round of the short indicator  $12 \times 12,000$  solar years. That gives us a time span of 144,000 solar years until our circular Universe becomes repetitive in functions and processes.

We could even go for more complexities, in which we introduce further spinning indicators

that multiply the 'ultimate time frame' to billions and trillions of solar years before we envisage repetition. For simplicity, however, let's stick to our earlier model of a maximum of 144,000 solar years, before things get repetitive.

We would like to 'create' in our Computerized Universe a nice 'stage' on which the main action is supposed to take place. We program such 'stage' by the example of our old good Mother Earth. Having done that, we populate our Computer Earth with various living beings in much the same fashion as it is on our real Earth. Finally we introduce 'computerized human beings' following, once again, our own reality settings.

Now, to make operations automated or at least semi-automated we need to write a screen play covering 144,000 solar years. Beyond, things will simply repeat; so we only have to program 'repetition' for that.

What is the general life span of our computerized beings to be? Once again, we follow the patterns set here on our Earth: some short-lived creatures and some long-lived creatures and some 80 to 100 years life span for our more intelligent 'human beings'.

Will our computerized human beings figure out our 'trick' of a circular universe that repeats every 144,000 solar years and thus realize that things are running in a circle? Likely they will not, as their life span of 80-100 solar years is very much shorter than our programmed circle of 144,000 years for the Universe they live in. For our 'computerized human beings' their world thus must appear as a 'linear' one that started sometime in the past and ends sometime in the future.

Time frame and associated processes perceived are relative to the eye and the life span of the beholder or participant in the 'play'. Only a being that 'lives' for more than 144,000 solar years could in our computerized example perhaps figure out that things are ultimately repetitive.

## **I.2.4 A most lovely entertaining Computer World**

Okay, we have now discussed all the 'options' for our Computerised World and have programmed it into our computer system. We push the 'Start' Button and off we go. As we are running our 'show' in a circular motion of 144,000 solar years, we could call 'START' our computerised 'Big Bang' that quite naturally will see only 'another Big Bang', when we push the 'STOP' Button after so many 144,000 solar year cycles. But had we introduced more

circular wheels into our 'clock' that runs our computerised Universe, then we could also have made circular systems with cycles of say 12x 144,000 solar years that start with a Big Bang and end with a Big Bang every 1,728,000 solar years. If we further envisage those 'Big Bangs' being 'perls on a necklace' that someone wears around its neck, things would still not be repetitive for each time frame between those Big Bangs, but only once we have made a full round through that 'necklace' in which each 'perl' constitutes a 'Big Bang'. The question remains, how many 'perls' are on that necklace. We can't even speculate on that...

But we realize some important fact: 'Big Bang' is not absolute but relative. There existed 'something' before a Big Bang and there will exist something after the next 'Big Bang' and things would not repeat, though everything is circular motion and action, till we have made a full round through that 'necklace' with an unknown number of 'perls' on it, each 'perl' constituting a Big Bang.

Let's sit back some time and marvel and contemplate on our 'chosen time frames'; certainly 'gigantic' compared with 80 to 100 years of a usual human life span.

### **I.2.5 The Universe WE live in**

The Universe WE live in is governed similarly as in our computerised example. It should not be too difficult for the eager researcher to figure out the actual time frame of our solar system cycle. The center point is the sun that itself rotates through a circle of 12 zodiac signs. That number of solar years that take our sun through all 12 zodiac signs is the main cycle of our solar system. Of course, within this frame of a solar cycle there are shorter cycles within the planetary arrangement of the planets of our solar system. There are also longer cycles in the stellar frame of the Milky Way Galaxy of which our solar system is an integral part. All these different system cycles compare to the 'wheels' of a giant clock, all of which are interdependent. In total, the entire Milky Way Galaxy is a carefully balanced and interdependent system that makes LIFE ON EARTH possible. Any disturbance of that harmonious balance has an impact on the harmonious balance of the rest of that giant system.

In a circular system we find, eventually, repetition. There is relative repetition found, of course, in our Milky Way Galaxy, but no absolute one. The largest 'wheel' within the movement of our Milky Way Galaxy Clock thus must rest beyond that Galaxy. Chances are that the largest wheel is based on a cycle started by a 'big bang' in very ancient times that is followed by another 'big bang' very far into the future. But considering a series of 'big bangs'

that are like 'perls' on a very long 'necklace' could be another possibility of 'the ultimate cycle'.

No wonder then that we human beings, having a life cycle of only 80 to 100 years at our disposal and knowing little about 'history' beyond some 5,000 years, perceive things as 'linear'.

If our solar system cycle is so much longer than our life span and 'knowledge' of 'history', no wonder then that we can come to incorrect conclusions.

## **The Eager Researcher**

This Offering of Ultimate Wisdom, too valuable to be sold for any earthly Gold or Money, is offered FREE to the 'Eager Researcher'. Eager research of the herein said remains a necessity for the reader and student of these lines. This is not a dissertation that aims at 'spoon-feeding' all the details. Self-Realization and Ultimate Understanding of the here presented Wisdom will only come, when one puts things to the test. Only then one can derive one's own realization and understanding. Otherwise we would remain just 'parrots' that repeat memorized phrases without having understood them ourselves. There appear to be candidates that have memorized entire so-called 'holy texts' without having ever lived and practised the injunctions of such texts. That's certainly futile exercise! Whatever one reads, studies or memorises one needs to assimilate, first, then carefully reflect about it and finally put it into practice. In a process of 'self-realization' then one will find the essence of what has been said in such text.

'Interpretation' is for the 'lazy mind' that seeks not Ultimate Truth and Wisdom, but a confirmation of one's own perception of things. 'Self-Realization' is a must for everyone who REALLY wants to know, even if it is uncomfortable to existing views and perceptions.

We hope that the readers and students of this Offering will opt for 'Self-Realization' based on a thorough research and application of the said and refrain from 'interpretation'.

### **I.3.0 The Creator and the Creators**

In this World of ours we may distinguish between 'a Creator' and 'the Creators'. People often accredit the 'Creator Role' to a 'God'. But who are 'The Creators'?

You have been born on Earth at some point of time and religion generally proclaims that God created you. Then you went to school and perhaps college and university to become a doctor or a lawyer. Who created that 'doctor or lawyer'? Who else then you yourself created that 'doctor or lawyer' by years of diligent study and practice?

If there is a God behind the scenes who created that marvellous universe with its perfectly automated processes that make human life on Earth possible after all, how does that God of the Macro Cosmos relate to the Gods of the Micro Cosmos? For being Creators ourselves we certainly are Gods ourselves. Otherwise we would be dependent on the God of the Macro Cosmos to create us as doctors and lawyers right from birth, wouldn't we?

We could go to the ocean shore armed with a large array of vessels in various shapes and sizes, couldn't we. Placing all those differently shaped and sized vessels along the ocean shore we could fill all our vessels with ocean water. We would certainly agree that, though shape and size of our vessels look different, all of them are filled with the same ocean water, wouldn't we?

The Gods of the Micro Cosmos relate to the God of the Macro Cosmos in a similar way as the water inside the 'vessel of the Ocean bed' to the water inside the differently sized and shaped 'vessels on the Ocean shore'. The 'vessels' are different, but the 'contents' are the same.

In such way the 'God of the Macro Cosmos' relates to the 'Gods of the Micro Cosmos'.

Let's take a moment of rest and reflect on our perhaps newly discovered status: We are all 'Gods' after all; relative, of course, and not absolute.

### **I.3.1 Joint Venture Operations and Team Work**

We are all Gods 'relative' to the God of the Macro Cosmos and the God of the Macro Cosmos is 'relative' to us. While the God of the Macro Cosmos takes care of the functions and processes of the Macro Cosmos, we are taking care of the processes and functions of our

Micro Cosmos circumscribed largely by our good old planet Earth. Of course, there are still processes and functions here on Earth that on present day scenario we have no or little control about, like climate and weather, the automated functions of our own bodies, and so on.

Then where is the 'borderline' of action and control between the God and the Gods? That borderline is relative and fluctuating. How come? We keep learning, over the centuries and millennia, to take more control. Of course, using radio and TV waves to communicate information or flying an aeroplane was possible also 2,000 years ago, but at that stage we had not learned yet how to go about it. So we see, we are learning and in this process discover new forms of self-expression.

If we really are Gods ourselves that relate so neatly to the God of the Macro Cosmos, then why can't we do the same things that the God of the Macro Cosmos is doing?

The answer is very simple: We haven't learned that yet.

And how can we learn that?

Very simple: The vessels in our illustration were all different, but they have a common denominator. The WATER 'inside' those vessels is the same in all cases. So all we have to do is focussing away from the 'vessel' that circumscribed the outside and focus on the 'medium' that is on the inside.

Presently all our attention is about the vessel, our human bodies, which are all different in shape and looks to such an extent that even the finger prints of two persons on Earth are not matching. That circumscribes individuality 'physically', but there is also 'individuality' mentally. And beyond mind and body there is something that we have likely never explored: Who is that being that talks about itself as 'myself'? That being is expressed as an individual in body and mind on the 'outside', but, as we just discovered, it is the 'inside' that we need to put our focus on, as it is 'the water inside the vessels on the ocean shore' that links to 'the water inside the ocean bed': Both are of the same nature!

Why is it important that we do connect with the medium on the 'inside'; why not just enjoy ourselves here on Earth and have fun?

Well, ultimately it is all about 'joint venture operations' and 'team work' between the God of the Macro Cosmos and the Gods of the Micro Cosmos. Though our 'powers' here on Earth are fairly limited, we can create the circumstances of our own self-destruction. We have already



realized that in a nuclear war there is likely no winner and now we are realizing that climate can go haywire, when we pollute our environment too much. Other realizations of such nature will come to us over the coming years, centuries and millennia. So we are in a process of learning. But is it really always necessary to take the painful road of learning through bad experience? Being Gods inherently, we have access to a vast field of knowledge that is based on wisdom. But that wisdom is latent right now within us, as we have never seriously tried to develop our inherent wisdom that actually makes us Gods. The base nature of a God is 'wisdom guided action', whereas the base nature of a typical human being is 'willful guided action' which is often wholly based around the 'me, my, mine, myself' perception. Such perception is commonly termed EGO.

Besides a person based EGO there is also a group EGO circumscribed by terms like 'we, our, ours, us' in contrast to other groups. We could group our vessels on the ocean shore by size. That would give us various shaped vessels grouped together by similar size. But that doesn't alter the fact that the water inside all the vessels irrespective of size and shape is of the same origin and same quality: in all cases derived from the water contained in the ocean bed. Human wisdom is slow to realize that, as all the focus is set to and on the 'outside'. Divine wisdom would perceive a world of 'we, our, ours, us' in which there are no 'others' or 'outsiders'.

Isn't planet Earth your home? Then WHY do you call yourself an American, a Russian, a Chinese? Is it just because the 'outside vessel' looks different? Divine Wisdom focuses on the 'inside' and sees the inherent connection beyond the outer difference of the looks of the vessel. In this realization a true God would never put the views, ideals or goals of an individual or a group of individuals higher than the common good for all. We are all Gods living on Planet Earth that is an inherent part of the solar system and further up of the Milky Way Galaxy. So a truly divine being would live, act and work 'in the interest and welfare' of at least all beings in the solar system, if not Milky Way Galaxy, irrespective of whether we have already found other 'Gods' living outside our Solar System or not.

It's all about joint venture operations and team work; the sooner we realize that the sooner we will be able to claim and express our inherent divine powers and qualities.

### I.3.2 Key Differences between Gods and Humans

We usually circumscribe ourselves as 'human beings' as we don't know that in essence we are the Gods of the Micro Cosmos. There are some key differences in attitude between True Gods and Typical Humans. It is up to us to choose now, whether we would like to be Gods or Humans.

As we have learned already above one key difference is that Gods see 'the big picture' while human beings typically limit themselves at seeing 'the small picture'. Limiting oneself on the small picture creates various 'interest groups' that promote certain individual views and ideas and follow various goals. In the interaction of such interest groups often conflict arises, as the 'views and perceptions' of WHAT IS BEST FOR US vary widely. The 'us' is then often limited to the actual members of such 'interest group' and not too the world's population at large. Such interest groups could be religious, political, business and so on. We may try desperately to 'sell' our views or the views of our interest group to others. We are convinced that 'our way' is the best way for everyone on Earth to follow. Traditionally, military and brute force were used to promote interest groups, though in our more modern days we are starting to realise that also other groups may have 'valid points'.

We will not in the following discuss which one is the best religion or best political system, but have a look at things from the perspective of a 'God of the Micro Cosmos' in comparison with the outlook from a typical human perspective.

Among all the creatures living here on Earth the human being sticks out with its ability to make rational choices. The other creatures are largely limited to instinctual choices. In which intellectual pattern our human beings typical make their choices?

Say, you are visiting someone and are asked by the host 'would you like a cup of coffee or a cup of tea'. What would be your reply? Typically you would make a choice selecting the coffee or the tea, wouldn't you?

A God of the Micro Cosmos would choose **both** the coffee **and** the tea, even at the risk of being considered 'rude and impolite'.

The choice of the typical human being is usually a **selective** one, whereas the choice of a typical God would be an **all comprehensive** one.

### I.3.3 Selective versus Universal

A key difference between a typical human being and a typical God is a 'selective attitude' for the human being and a 'universal attitude' for the God.

Such 'attitude difference' extends into all walks of life and existence. Here we are just mentioning a few:

Nationality, Culture, Class/Caste, Religion, Gender

A typical God of the Micro Cosmos would be Multi-National, Multi-Cultural, Multi-Class/Caste, Multi-Religious and Multi-Gender compared to a typical human being that expresses Single-Nationality, Single-Culture, Single-Class/Caste, Single-Religion and Single-Gender.

We see here some crucial differences in both perception and attitudes. While we may still be able to come to terms with the first two or three we certainly will start struggling when things come to 'multi-religious' and 'multi-gender'. Could anyone realistically be a Christian and a Muslim or even male and female at the same time? That's impossible, the typical human being would proclaim. It's basic nature, the true God would proclaim.

If that's the difference between the Gods of the Micro Cosmos and the typical human beings we are presently, then perhaps we better stay 'human' and don't try to be Gods...

The God of the Micro Cosmos would laugh heartily and proclaim: But that's all basics what the human beings perceive 'impossible'. It's only because human beings are looking from the opposite perspective, the one of the CREATED rather than the one of the CREATOR that things are so difficult to understand. Didn't we all, essentially, come from the God of the Macro Cosmos that 'divided' into human beings like the water of the ocean in our earlier example was 'divided' into vessels of various shape and size.

In our inherent nature of a 'God' we are Everything, while in our inherent human nature we are just 'Something'. This is one of the hurdles we as human beings need to overcome to claim our right to be Gods.

Saying 'I am a God' doesn't make anyone a God, but changing one's outlook on things in thinking, feeling and action to divine standards, of which an inherent multi-consciousness is

one of the key attributes, opens the door to really being a God of the Micro Cosmos endowed with all the wisdom and understanding that is due to a God, but eclipsed from a human being.

## **The impossible feat of being multi-gender**

Remember, when we lined up all our variously sized and shaped vessels on the shore and filled them with ocean water? All those vessels regardless of size and shape are filled with exactly the same ocean water, aren't they? Let's assume that some of those vessels were shaped as women and some shaped as men. Even in such case the water contained in both the male and female shaped vessels is still the same as in the ocean, isn't it?

We see here in all clarity that being male or female are 'externals' pertaining to body and mind, but not to us who are in essence Gods of the Micro Cosmos relative to the God of the Macro Cosmos.

The common denominator in all of us is the inherent nature of a God that was super-imposed 'for practical purpose' with male and female gender characteristics. While expressing male or female outwardly in body and mind, in our inherent nature of a God we are gender-neutral. Another expression of 'neutrality' is pertaining to the qualities or nature of both or all sides EQUALLY. That simply means that the God of the Micro Cosmos, while 'neutral-gender' in its base nature, would express dual male and female equally in a human role. But due to one-sided superimposed human nature and upbringing the God develops selectively into male OR female while such God should strictly be EQUALLY MALE AND FEMALE. Such one-sided nature and expression, however, has psychological consequences very deep within the subconscious mind. Missing, very dearly, that missing other gender nature within, the God seeks to satisfy that need where that God, now a human being, is usually looking for satisfying all its needs: in the surroundings of an **outside** world. Luckily, there are some other 'vessels' of the opposite sexual nature and upbringing equally one-sidedly 'programmed' as our God and both 'fall in love' out of a deep inner necessity to compliment what is missing in the subconscious mind. That's the actual background WHY opposite gender persons fall 'in love'.

Occasionally, someone comes to Earth who is more conscious of that missing nature within and 'falls in love with itself'. Here we find the true roots of transgenderism. The one who does feel like being born in the wrong body does feel so, because such person is more advanced in its quest of being a God of the Micro Cosmos in comparison to a typical human being. Over

the coming millennia the number of persons craving transgenderism is likely to drastically increase, as the number of those claiming their inherent 'Godhead' is likely to increase.

However, ignorant of the fact that they are 'Gods' in their basic nature and in this context 'gender-neutral' the typical transgender person may desperately try to become 'the opposite' to what such person is in physics and upbringing right now. The important clue that neutrality expresses as 'multi', but never selective the one or the other, is still missing in the human world. Such clue is given to the human world right here in this Book of Ultimate Wisdom.

Another clue that will be given in the following chapters are the Nature and Message of the legendary Philosopher's Stone, of which it is said that it changes everything into pure gold that one touches with it. Of course, the treasure here is 'golden wisdom' and not physical gold, as in the world of true Gods of the Micro Cosmos gold, silver and money are of little value.

That's another key difference between a typical God and a typical human being: The human being calls 'gold' its treasure, whereas the God calls 'wisdom' its treasure.

## **I.4.0 The Role of Clergy and Religion**

Religion is Opium for the people - and all too often it appears like religion is just that: a way to escape from the realities of daily life by drugging oneself.

On the other hand there is a so-called Clergy that has to deal with people who see or practice religion like drug addicts. Why can't that Clergy step in and clarify that religion is not supposed to be opium or a drug of any kind?

The 'Clergy', more often than not, is financially dependent on their devotees. Being financially dependent the clergy is, in a sense, an employee of those whom they are supposed to teach. In such an unfortunate situation it would be very dangerous for the clergy to 'offend' their sponsors in any way. Offending their sponsors-cum-devotees could lead to them turning away from those who teach them and seek out the teachings of someone else who is more supportive to what the sponsors-cum-devotees expect to hear and see. Motivated by such fears the clergy generally interpretes holy texts selectively or doesn't tell people the full story. Beyond, since centuries it has been common practice that clergy was politically exploited, either by their own politically motivated superiors or by politicians of some state generally. Thus the 'good guys' within the clergy were motivated to follow the views and expectations of superiors, politicians and finally their particular congregation. Disobedience was punished severely up to excommunication, emprisonment and even execution. 'Saints' there may have been many, but they were often unable to speak up. Beyond, any priest is an employee of its institution and as such held to express the views of its institution and not its own.

Under these circumstances many clergy members were silenced efficiently; life and welfare of the individual clergy member were dependent on that they were 'obedient' to both institution and congregation. The attachment to daily food and well being is usually stronger than all commitment to truth and wisdom.

### **I.4.1 What is the role of Religion?**

Religion is, all too often, a watered-down or misinterpreted presentation of the teachings of some master. Many masters have come over the millennia and many more will come to teach individuals and masses. Contrary to some belief concepts of existing religions, there is not just one messiah or prophet, as we are speaking not only of a few thousand years, but tens and hundreds of thousands of years. Processes of the Universe are circular and not, as often

perceived by people, linear in a fashion in that there was a start and there will be an end. The Universe and all existence therein are relative-repetitive and the time frames that we are looking at are gigantic compared with a normal period of life of a human being. Processes being circular-repetitive suggests that there will be periods of more clarity of mind and periods of more confusion of mind. We are all Gods and don't know it! How come? Do we live in an epoch where mind confusion is so high that we don't know anymore 'who' and 'what' we are?

Masters, Messiahs and Prophets have come, again and again, to acquaint us with the facts. They spoke in different languages to different people of different understanding at different times. One simply can't talk to a small child the same way as one can talk to an educated adult. One can't expect a small child to understand university mathematics, when such child has not even learnt the very basics of mathematics in pre- and primary schools. Therefore teachings were largely 'tailored' to the overall understanding of those people to whom they were given. Beyond, people of different background and times had their most cherished existing customs and traditions that they were eager to continue to pursue. Thus, teachings of wisdom were soon turned into a watered down interpretation incorporating in addition also the existing views, superstitions, customs and traditions. That's what we call 'religion' in contrast of what we call 'wisdom'.

But religion still has value overall. Though being watered down wisdom, it still contains some elements of wisdom. It is up to us to search and identify such wisdom. After all, religion may be all that we have at our disposal on our initial search for ultimate wisdom. Then there might be 'Philosophy', often equally misinterpreted and watered down like religion. And then there is what we call 'Science' these days. Ultimate Wisdom has to be able to incorporate all the views of Religion, Philosophy and Science equally. Impossible? Why not give it a serious try?

### **I.4.2 The role of the Clergy**

It is the role of the Clergy to introduce us to the 'Concept of Religion'. While there are different religions available, they are relative to each other in a sense that none of them teaches ultimate truth and wisdom but all of them contain relative wisdom. That is, because those religions are 'watered down' versions of Ultimate Truth and Wisdom, each watered down differently in a fashion that they now appear different from each other.

Imagine a pyramid with four sides. On the bottom of each side of the pyramid are different people arguing with each other that the best side to climb the pyramid is their own. They try their level's best to convince the teams on the other sides that their own side is better than theirs. In this attempt they waste their 'few years on Earth' away and never even attempt to do the climb.

As a matter of fact, all sides of the pyramid are relative to each other in that they all lead to the same peak on the top of that pyramid. The one that wouldn't have wasted its time in arguing and rather had climbed up would have seen for itself that all the four sides of the pyramid equally lead to its top. But one would have to be at the top of the pyramid to really see that.

So don't waste your years on Earth with arguing and perhaps changing religion. Rather start the climb from wherever you are. All four sides of the pyramid lead to the same top; the challenge for the climber is the climb, not the side from where the climber climbs up. There are no easier or more difficult sides. Challenges faced may vary at different points of time, but over the entire climb the individual challenges sum up to be equal to each other. While on one side one might face a difficulty very early in one's climb, on the other side one might face the related difficulty later in one's climb. That is, because the basic training of each climber was different from the start. The start, that is birth here on Earth. Basic training is what the clergy was supposed to bestow along with other earthly instructors and teachers. But none of those is qualified to teach Ultimate Wisdom as perceived from the top of the Pyramid, as for Ultimate Wisdom one will have to do that climb oneself. Even we can't give you Ultimate Wisdom, as for Ultimate Wisdom your own experience is necessary. In the same way as we or anyone else can't eat for you to fill your stomach, but you have to eat yourself, Ultimate Wisdom is dependent on you making your own efforts: that's to climb up and don't waste your time with arguing and trying to convince others of the 'best side' to climb up from.

It is the Role of the Clergy of your respective Religion to provide you with the basic clues and introduction. That is all they really they can do for you. It is not their role to hold you down on their 'level of belief' (in fear of loosing perhaps a sponsor or supporter) nor can anyone see you through for your entire climb. Religion and clergy can support you to a maximum of about the lower 20% of that climb; beyond those 20% you'll be on your own. But having been introduced to the 'concept' of a God of the Macro Cosmos who is relative to you, as you are in essence a God of the Micro Cosmos, will help you to orientate correctly and seek help from where help surely can be expected: from your inner self that relates to the universal self like the water of the vessels on the shore to the water in the ocean bed described in Chapter 3.



## Why study the Book of Ultimate Wisdom?

Why study the book of Ultimate Wisdom, when even its authors can't give you Ultimate Wisdom?

Ultimate Wisdom can't be 'spoon-fed', because it is based on a process called Self-realisation. Otherwise one would only be a 'believer'; not a knower of things.

Do you 'believe' in God? Whatever your answer to this question, don't be satisfied until you have actual KNOWLEDGE of whether there is or isn't a God. Whether you support or negate the existence of God or a God is irrelevant. Relevant is only what you KNOW. Disputing the existence of a God without having done one's own diligent research is equally foolish as blindly believing in a God. Saying that the one who blindly believes has no proof is no proof that there isn't a God. In such context the atheist is as foolish as the blind believer. Only the one who has done thorough and diligent research has the right to speak. You have never seen God? How come? Are you blind? How come you can't see God? Perhaps you just don't know what God looks like. Have a closer look and once you figure out who and what is God you will see God everywhere.

It is not up to us or this Book of Ultimate Wisdom to tell you what 'God' looks like. We're not spoon-feeding anyone. You got to conduct your own thorough research. Disputing the existence of a God simply because you haven't seen God yet or because someone else has not proven God to you you are as 'blind' in your approach as is the 'blind believer'. It is not up to others to prove things to you, but it is up to you yourself to prove things to yourself. Refusing to do that and waiting to be spoon-fed or others proving things to you you are acting irresponsibly and thus have no right to speak.

This Book of Ultimate Wisdom is just giving you a few clues and perhaps new thoughts and ideas for your own research. Then you are on your own. You got to conduct the entire research yourself. There is no other road to Ultimate Wisdom. There is no other road to self-realising yourself as the God of the Micro Cosmos that you really are. You must KNOW that in every cell and corpuscle of your being; otherwise your mind won't accept that and firmly hold you down on your habitual human plane. To truly being the God of the Micro Cosmos you must be able to speak out of your own inherent 'self-realisation'; otherwise you are just a parrot or simply a blind believer.

Saying 'you are the Prime Minister' or 'President' of a country doesn't make you the Prime

Minister or President. But you have it within the framework of your own possibilities to really become that, if you are prepared to really work hard towards achieving that goal. In the same sense you may have to work very hard to actually BE the God of the Micro Cosmos that you really are. All it takes is realising this truth out of yourself and then living and acting as one. One needs to be able to think, feel and act like the God of the Micro Cosmos to really be that. Two clues for you to this end: The God of the Micro Cosmos is the most humble one; not the biggest show off. And being able to perform miracles is no proof of being a God of the Micro Cosmos. But the one who has 'miracle power' at one's disposal and has the self-control NOT to use it, neither for oneself nor for others' benefit nor even shows off with its super-human capabilities, may be on the road to become a True God of the Micro Cosmos.

## **I.5.0 The Queen of the Amazons**

There is a legendary tale from South America telling of tribes that consisted only of women; men were not allowed or be simply enslaved. How could a tribe of just women multiply, when there existed only women in the tribe? They may have copied their tribal system from nature, perhaps the bees, in some sort.

Once in a while, quite rarely indeed, a child is born with gender characteristics that are called 'hermaphrodite'. Such a child is a sort of 'siamese twin' in that it incorporates male and female gender characteristics in one body and may later depict both male and female natures in its mental perceptions, if such child was nurtured and brought up 'dual' by parents and society.

Where would such a child fit into the Amazon Concept? It's likely to be perceived to be special in as far as being a woman that can make other women pregnant. In such capability a hermaphrodite is entitled to be called a 'Queen of the Amazons'.

It has become customary under the guise of 'religion' and 'law' to surgically alter babies that are naturally born 'hermaphrodite'. No one can be both male and female in one person, religion and law insist. It would be interesting to research, in all honesty, how such child that was born hermaphrodite fared in its life after having been surgically altered into single gender male or female. One can surgically alter the body, but one can't surgically alter the mind.

## **I.5.1 Human and Divine Outlooks**

The human and divine side stand to each other like mirror pictures and could be compared with the relationship between a photo negative and a photo positive. Both photo negative and photo positive are true images of each other, but they don't look the same. In an absolute approach they are looking very different from each other, while in a relative approach one can quickly discover that they are just opposites of the same: colour, light and side reversals of each other.

In terms of photography, the human and the divine are nothing else than photographic reversals of each other. Both are unreal in a sense as that they are mere 'projections' out of a 'third' that we don't know yet about. In photography, both photo positive and photo negative are mere projections produced out of a camera. Both are reversals of the same, 'frozen moments' or 'depictions frozen in time'.

A movie, as we may know, is nothing else than a sequence of still photographs added up in a sequence. The frames per seconds shot may vary, but even here we are speaking of negatives and positives. The advent of 'digital photography' has made many users unaware of what is actually taking place in photography; the reversal from initial photo negative to photo positive happens automatically in our sophisticated cameras so that we may never become aware of what really has happened here and how our lovely photos have come about.

The human and divine sides being like photo negatives to photo positives in comparison have an interesting angle. If one overlays a photo positive with a photo negative on transparent film and then projects a light beam through the set, the picture that they display simply disappears. In the same sense, if we were able to overlay our human nature with our inherent divine nature in equal proportions, both the human and divine concepts would simply disappear. Both being just 'concepts of perception' we say they are both unrealistic; they can be produced by means of projections out of a 'third', in a similar way as in photography both photo negative and photo positive are projected stills out of a camera. A big question arises here: What is the 'third' in relation to human and divine? At this stage we can only marvel about it...

## **I.5.2 Hermaphrodite - a Clue to Ultimate Wisdom**

What does it really mean to be 'hermaphrodite'? What does it mean to be both male and female not only in body, but also in mind and consciousness?

The ancients living more than 3,000 years ago have marveled plenty about such concept. What was known as hermaphrodite in ancient Greece, was described as Ardhanarishwara in ancient India and entertained in a 'Ying and Yang Concept' in ancient China.

Interestingly, both ancient Greek and ancient Indian (the Sanskrit language) had three genders in their languages and not just two as in most languages these days. What is the gender of the sun and the moon? In modern English they have no gender, but in modern French and Italian they have. And in modern German one also distinguishes a third gender which is called 'neutral', neither male nor female. Interestingly, ancient Latin, the language of the Romans, also distinguished three genders, while the languages derived from ancient Latin, such as Italian, Spanish, Portuguese and French have only two genders in their languages. What has motivated people to drop the third gender? What has motivated the Indians to reduce the three genders of ancient Sanskrit to only two genders in modern Hindi? One can only conclude that

for some reason people got confused about the meaning of a third gender and simply dropped it off as 'irrelevant'.

### **I.5.3 Ages of Wisdom and Ages of Ignorance**

This World and Universe move in cycles over lengthy periods of time that much exceed the short life spans of human life here on Earth. Seeing no repetition of universal nature in our life times we come to the incorrect conclusion that things are linear with a start and with an end to it.

In our solar system we find a cycle of some 24,000 solar years which it takes the sun to 'cycle' through all 12 zodiac signs. We, the inhabitants of the solar system, are directly affected by that. There are periods of wisdom over a 12,000 solar years arc and periods of ignorance over another 12,000 solar years arc. Of course, such wisdom and ignorance are relative and not absolute. In our present time of the Christian 21st century we observe an increase in knowledge and understanding. Such development is suggestive that we have been through an arc of ignorance and are simply 'recovering' again. Our exact location on that arc is speculative at this point of time. But it could well be that 'simple facts of life' of an earlier generation living some 3,000 to 6,000 years ago have simply been forgotten in an in between spell of ignorance. How come we don't know that we are Gods in essence, when our holy scriptures clearly point us to that fact? Could it be that we simply 'forgot' that we are Gods by being 'so busy' in our ways trying to be human?

### **I.5.4 The Clues left behind for us from Higher Ages**

A clue for guidance has been left behind for us from Higher Ages, when people were more intelligent and knowledgeable than we are even these so-called modern times. It is the clue of the Greek 'Hermaphrodite', the Indian 'Ardhanarishwara' (sometimes also spelled with 'v' instead of 'w') and the Chinese 'Ying+Yang'. It is the clue to tell us HOW to uplift ourselves back into our inherent Divine and Super-Divine Status. It also is the clue to understand the nature of our Universe, its creation and functioning, its mathematical perfection and structure and our own existence within.

The Secret, if it is a secret at all, has also been preserved in the legendary Philosopher's Stone of which it says that it turns into GOLD everything it touches. The Philosopher's Stone is not

physical but symbolic in the same sense that Hermaphrodite, Ardhanarishwara and Ying+Yang have largely symbolic character. The Philosopher's Stone produces 'golden wisdom', not physical gold as some alchemists are dreaming. But one needs to know how to use it to benefit from its wisdom.

## **The Secret of the Universe revealed**

The Secret is an open one for those who are acquainted with photography. It is also an open secret to those who are acquainted with science, mathematics and processes of nature. There isn't really anything 'magic' about it; in fact, we will wonder, why we haven't realised it long ago. We see 'it happening' right in front of our eyes in our daily lives here on Earth and still can't see things? How come? It is the same that we think we can't see God when we are seeing God in fact every day. It is simply that our minds have somewhat become 'numb' to finer perceptions. We see - and don't see; we hear - and don't hear. All we have to do is learning to see and to hear to be able to understand. Is this too much to ask from anyone?

We know, it is a big challenge to give Ultimate Wisdom and Knowledge to the people living in the 21st Christian Century. Such knowledge is centuries ahead of time and the human folks aren't really prepared for such information. For one thing, the message of the Philosopher's Stone contradicts all human interest and yearning, as its message is a divine and not a human one. A major difference between a human being and a God is that the human being craves physical gold and the God craves golden wisdom. Earthly treasures like money and gold hold little attraction for a God.

One is born a human on Earth, but everyone has the inherent ability to develop itself into a God. No one is born a God on Earth, as Earth is a place that presently isn't really meant for the Gods. As humans we do not remember our inherent Godhead. In such sense of us not knowing who we really are Planet Earth is considered, looking from a divine and not from a human perspective, a 'mental hospital for Gods that have lost their mind and memory'. As such a healthy God presently really has no place on Earth; it is meant a place for those Gods that lost their memory and are no struggling to come to sense with their own being and existence.

Of course, those 'mentally ill Gods on Earth' are only temporary mentally ill. In a theatre play the actor puts on a mask and a costume and plays a role pretending that such actor is someone else than in real life. Only if that actor loses the memory of who such actor is in real life, we

would call that actor 'mentally ill', wouldn't we? It is the same with us being Gods. As long as we remember our inherent Godhead and the 'rules of the play' here on Earth we remain healthy Gods. But who does really remember being a God these days and in actuality knowing 'the rules of the play'? What 'rules of the play', you might ask now and here is the problem in our human existence on Earth. We haven't only forgotten that we are Gods, but we have also forgotten that there a 'rules' to the play. No wonder then that the Gods outside Planet Earth perceive us as mentally ill and Planet Earth the place for us to recover again. Recover from what? Recover from our mental error that we are humans and remember the most crucial 'rules of the play' again.

We do know that being perceived 'mentally ill' is like a shock, if not an insult, to every human being perceiving itself as sane and healthy. Therefore we must clarify again that it is NOT the human being that is mentally ill, but it is the GOD within every human being that is mentally ill having forgotten its true nature and being. This is high psychology; so please take some time to think about and digest that.

Ironically, the only one who can help that God to 'snap out of it' is the human being that such God displays. That is you in your present human role. You are the only one who can help the GOD in you to come back to senses in a process called 'remembering'. In such arrangement you, the human being, are the DOCTOR and the ignorant GOD within you is the PATIENT. The big question here is: Will you take up the big challenge to be the DOCTOR for the erring GOD in you and help that God in you to wake up from its dream of being YOU?

It is all psychology, nothing else. As the God in you starts waking up, you will remember again that you are that God yourself and will want to be that God rather than a frail human being. It is all in your own hands now: remain a frail human being as in your present misperception or take up the challenge to recover in Godhead with ultimate knowledge, wisdom and understanding.

## **I.6.0 'Hurrah, I'm a God; let's go out and have fun!'**

Careful! Things are not as simple as they just appear. You are, presently, a God in THEORY, but not in PRACTICE. Having forgotten all about your inherent Godhead, you need to learn things all over again; mainly in a process called 'remembering'. For the first, you need to remember that the GOD in you is your image or mirror picture. If you are a photo negative, the God in you is likely to be your photo positive. Just saying or mentally brainwashing yourself to being a God doesn't make you a God. You must be able to think, feel and act like a God under all circumstances, especially challenging situations, when you would act automatically out of age long habits of mind. You must be in control; not be controlled by your habitual whims and moods. You will need to learn the crucial facts and rules of Godhead to qualify to being a 'doctor' to the erring God within you and remind such God of 'the facts' and not to just follow the habitual 'whims'. That's a big challenge ahead.

First, as thinking usually comes before acting, you must learn to 'think like a God' and for that you must know and understand, how a God thinks. In human perception a God is an all powerful being that could bestow reward and punishment to the human being and therefore should be 'appeased' with sacrifices. This is, of course, foolish human misperception. The true God can't be 'bribed' under any circumstances. And a God isn't the one that sits 'in judgement' of others; the true God only judges itself.

What has been perceived as 'punishment from the Gods' in historical times has been none else then automated reactions from the Universe to human folly. A big flood is being said to have been sent by an angry God to punish humanity to a point that there were only a few survivors left. That's nonsense, of course. If there was a big flood, it was the direct result of the human beings imbalancing their own world and nature.

We speak of 'Global Warming' these days and drastic changes in the world's weather patterns. If such changes of weather kill millions, would be that the result of 'a God' punishing us or simply the natural consequence of us polluting nature too much? It is the same in all other cases where human beings felt a God or Higher Being is punishing them. In all cases we have invited such punishment ourselves as a consequence to errors of the past that we might not even remember anymore. Retribution is automatic in the universal set up and no God is punishing or rewarding us. This is the first important lesson in our existence here on Earth: We are the manufacturers and judges of our own destiny.

When 'religion' speaks of the 'wrath of God' then someone is clearly misguiding us. Reward



and punishment here on Earth are of our own making; after all we are, though ignorant of such fact at present, Gods ourselves. It is our sense of fairness and justice deeply buried in our subconscious mind, the God within us so to speak, that we punish and reward ourselves. For such understanding you have to self-realise yourself as the God that you really are and in such process remember again all the 'rules of the play' in which you, as an all awakened God, are participating. Breaking the Rules of the Game, knowingly or ignorantly, invites automatic retribution. No God is involved in that; it's inbuilt in the basic structure of nature and universe. Ignorance doesn't protect from punishment; if ignorantly you break a law in your country, police will step in and you'll be punished just the same. It is our earthly set up of some authority stepping in and punishing us that has led to the misperception that there is also a universal authority that rewards and punishes us. It is our political set up of having a king or queen governing our country that in the past we have come to the erroneous conclusion that God is like a king that needs to be worshipped. 'Praise the Lord', we hear people sometimes proclaim. The 'Lord' is not like an earthly king that responds to praise and flattery.

### **I.6.1 Striking Qualities of a True God of the Micro Cosmos**

There are some striking qualities pertaining to the TRUE God of the Micro Cosmos that are contrary to widespread human belief and perception.

The GREATEST is the one who is the most HUMBLE one. This goes essentially for everyone, but in particular for a True God. We will in an upcoming chapter explain in more detail, why the 'most humble' one is also the greatest one. It is inherent to the very structure of our Universe.

So the one who thinks, being a God means going around town and showing off, is mistaken. A True God never shows off; nor will a True God brag or show off superior qualities and abilities. There have been incidents in history where great saints overstepped such rules and have finally ended up in dire straits. Jesus Christ is such an example. It is NOT the job of a true saint to go around healing the sick and suffering. That's the job of the human doctors, who could become irate, when someone makes them jobless. Out of the angle of a human being, of course, such a magic healer is perceived a blessing. But certainly not for a doctor that loses the patients, the source of income to care for itself and its family. Here we see in all clarity that a True God must give EQUAL credit and consideration to ALL the parties involved. If a True God involves itself in an act of supernatural healing, it would be a very great exception.

## I.6.2 Why do we suffer here on Earth?

We suffer, because we have, knowingly or inadvertently, broken some Rules of the Play, in which we all are volunteering participants. It is therefore adamant to acquaint ourselves with the Rules of the Play. These Rules can be easily understood, when we understand the cause and the structure of our Universe. As we for the most of us still don't even know how we came to be here on Planet Earth and satisfy ourselves with following some belief concept rather than actual facts, we will discuss Universal Law and Structure a few chapters later. Out of a human perspective the Rules of the Play may appear to be confusing, when they are all logical out of a divine perspective. It is therefore best for us to first learn to THINK LIKE A GOD.

In a nutshell, ask yourself, whether it would be appropriate, in society's interest and perception, if a True God would go and open all the gates of human prisons and let the murderers, rapists, thieves and so on run free. Your answer would most likely be 'no'. And why? It's because you as a human being can easily relate to human law that has originally brought these criminals to justice. In the same sense as the True God of the Micro Cosmos can't just release all those criminals from human prisons, the True God can't release everyone from the 'cage' of suffering. In the earlier case human justice would be turned upside down, in the latter case universal justice would be put to ridicule. We suffer the direct consequences of a misbehaviour under Universal Law. But there is no God our judge that submitted or punished us to such suffering. In all cases it has been ourselves who have judged and punished us for our offences. You may not agree with such terms as a human being, but once you have learnt to think and feel like a True God, you will see that for yourself from a divine perspective. Here we find another striking difference between a typical human being and a True God. The typical human being wants to be free from all suffering and lead a happy and content life. In case of physical illness such human being typically will be quick to take illness suppressing medicines to get well soon. The True God, in contrast, while not inviting illness, will humbly suffer and at its best take medicines that bring such illness out rather than suppressing it, knowing that illness forcibly suppressed will strike a bit later more vehemently again. So, in a nutshell, a human being is an opponent to suffering, while the True God is a volunteer to suffering. Makes no sense to the typical human being, does it?

Then why would anyone want to be a God? The ignorant would not like to be a God, but the wise prefers to be a God to KNOW and UNDERSTAND what is going on and thus be able to act and participate with wisdom in respective situations rather than with ignorance. The ignorant suffers without understanding, the wise suffers with understanding.

### I.6.3 "We don't need to be a God"

"If there is no benefit to human terms and understanding attached, why would anyone with brains want to be a God? Let's rather stay human and enjoy as long as we're here. One lives only once!"

"We believe in 'our savior' and forgiveness of sins; we will go to Heaven after death. Then what is there to worry about?"

"God is all forgiving; if we repent, we will be forgiven and be saved to Paradise after death. So what about all that nonsense of us becoming Gods?"

Plenty of objections from the human side that essentially just 'believes', but doesn't 'know' anything. Belief concepts there are many; one is held 'to believe' in absence of any proof being available. One could basically 'believe' anything, like people once 'believed' that Earth is the center of the solar system and the sun revolves around the Earth. As long as science could not logically explain that things are the other way around, blind belief was fine. But what happened, when scientists came forward with their latest discoveries and proved belief wrong, we can read in our history books.

We continue living with 'wishful' belief concepts till someone steps forward to prove us wrong. There will be likely some standoff and dispute and finally 'religion' and its institutions and clergy will make the necessary amendments and adjustments. That's the way things have been in the past. It is interesting to see in such respect that often the 'belief system' is upheld, first, and the contents of the relevant holy books and texts considered, second. Why else would clergy and its institutions alter holy books and texts or remove parts thereof that are throwing up questions in respect of the propagated belief?

Did you ever investigate the 'history' of your holy book and text that is the foundation of your existing belief concept; how and under which circumstances it came into being, by whom such texts were translated into your language, and why one talks so much about 'interpretation'? Does that mean that even the scholars are not sure about such texts so that 'interpretation' becomes necessary? Perhaps such scholars with all their university degrees are just the wrong people to translate and teach the contents of such holy books; after all, most of the masters that are considered the initial teachers did not have an university degree. Perhaps something else than an university degree is needed to understand such writings. If you'd be a true God of the Micro Cosmos you might be wholly understand your holy books and texts.

## **You ask for proof, you say ...**

We will give you all the proof you need; for that purpose this Book of Ultimate Wisdom was written and compiled. But to deal with actual proof you will need to be able to view this world and all the living beings in it from different perspectives. There is first your own human perspective based on your own upbringing. Then there is the perspective of the God of the Micro Cosmos that inherently you are but have not realised yet and then there is the perspective from the Third Angle that is the common denominator of both human and divine sides. Some things you can understand from the perspective of a human being, the 'Created' so to speak. But as long as you can't mentally place yourself 'in the shoes of the Creator' and understand why and how this Universe came into being, your understanding will be lop-sided. To access such crucial information you need to learn, in part, to think and feel like a God of the Micro Cosmos who is inherently connected with the God of the Macro Cosmos like ocean water collected and stored inside vessels along an ocean shore is inherently 'connected' with the ocean water in that Ocean itself, by simply being of the same kind as it was taken from the Ocean. Your pre-qualifications of thinking and understanding are crucial therefore. You want proof? You will find all the proof you need and want in these pages. But you must be willing to adapt your consciousness to higher levels of thinking and logic and be willing to amend your existing belief concepts to the new concepts that you start understanding. This is a practical journey not suited to scholars who just read and interpret without actually living and applying knowledge in their daily life and affairs. To understand one has to live things; not just talk about things. Ultimate Truth is very simple; but one must have the courage to step away from existing ways and beliefs and risk being discriminated by family and society. Things are not like human beings currently perceive. Things are quite different, indeed. Learn to develop the inherent God of the Micro Cosmos in you and you shall understand in all clarity of mind and logic.

If you want to give it a serious try, please read on. If you are afraid or unwilling to develop yourself further and rather continue to follow an unproven belief concept that may be just based on 'wishful thinking', then please put this Book of Ultimate Wisdom away, as it is not written for you. And finally, please refrain to investigate things 'in theory' only; ultimate wisdom is practical and based on practical experience. Ultimate wisdom doesn't suit scholars that simply want to get information to discuss and debate about. It is largely, though not only, the highly studied scholars of our times that have confused things, as they did not understand themselves. The true understanding is not in study, but in actual life and practice that understanding comes. Remember, the masters from whom such teachings originated from were, in all likelihood, not university laureates. So you can understand, too.

## **I.7.1 We shall be forgiven; so why worry?**

We shall be forgiven, some religions of the 21st Christian century proclaim. Then what is there for us to worry about?

Let's have a look at the following scenario: One of your loved ones is brutally murdered, the miscreant apprehended and produced in court. The judge releases such criminal in an act of forgiveness. How does that make you feel? Won't you feel hurt? Won't you feel upset that the judge ignored your feelings and just set the criminal free?

Then WHY would a loving God 'forgive' ones sins without due consideration for the feelings of both victim and victim's family?

Before accepting such blind belief concepts, please put yourself into the shoes of the victim and not just into the shoes of the evil doer that seeks forgiveness. It is your one sided thinking and positioning that leads to such misconclusions. Of course, as long as the affected parties do not forgive your crimes, the God that you worship can't forgive your crimes either. Such forgiveness would be utterly unfair to the party that has been hurt by your inconsiderate actions.

If you now study your holy scriptures a bit more honestly, you'll find that, for starters, forgiveness must be reciprocal. Those who are unwilling to forgive those who have offended them, can't expect forgiveness for themselves. But if in an act of mutual forgiveness everyone is forgiving everyone, then where is there a need for a judge? If no one accuses anyone, then there is nothing to forgive. If you expect forgiveness of your sins for yourself, please be the shining example for others in forgiving everyone that ever has offended or hurt you and/or anyone of your loved ones.

But please don't cling to false belief concepts affording yourself forgiveness for all that you have done while insisting that your offenders will be thoroughly punished. Have a close look at your holy scripture again, as it says that there; that's unless your holy scripture has been modified by someone that has been out to clearly misguide you.

## **I.7.2 Eternal life in Heaven is awaiting us ...**

We will be discussing, in detail, at a later stage, what perceptions of 'eternity' and 'infinity' actually constitute.

For the moment just picture the following fact: For millennia people have hoped that they wouldn't die, be able to live in the same body at a much better place in everlasting peace and harmony. And then someone propagates a belief concept that just promises exactly that. Isn't that strange; all dreams of humanity coming true?

Doesn't that sound just like fulfillment of one's wishful thinking?

Our problem as human beings is that we are thinking linear and not circular, absolute and not relative. It is our own thinking that creates the ground for others to embed such wrong information in our hearts and minds. If we could see the World and this Universe for what they actually are and be able to think and feel as free Gods of the Micro Cosmos, we'd never fall for such publicity stunts as someone promising us an eternal life in heaven or paradise in lieu of us being good people here on Earth. That's wishful dreaming and thinking.

Why would a God, and you are a God, lock itself up eternally in an enclosed space no matter what its dimensions? You are a free bird of the Universe and beyond. Then why claim a 'golden cage' as your permanent home after earthly death? It is your own misperception of a frail human being that makes such option an attractive one. A God would never fall for such an offer; there are much better options 'out there', but to appreciate them one must have learnt, here on Earth, to think and feel like a God. Would anyone that is put into jail for some crime want to stay there forever? Doesn't every prisoner hope to be released from jail some day again? Then why would you want to imprison yourself in all eternity in a golden cage that in the end is just a prison, no matter how golden? Wake up from your human dream and see for yourself that you are a God, a free bird of the Universe.

Just for a thought, what would life in Heaven or Paradise be like based on human feeling and understanding? Some see Heaven as some septic place out there in space, others as a Garden Eden established here on Earth after all the bad people have been removed. Whatever it is, one usually expects 'all dreams come true'. But have you ever met some person who has everything here on Earth and is thus happy and content? Very rich people that can get or buy anything they want are often quite frustrated beings. Those living in golden cages aren't happy either. How come? It is so, because the God craves Infinity and Eternity which are its

inherent nature. Any form of limitation, no matter what it is or constitutes, leaves some craving deep within the subconscious mind. Infinity and Eternity are your inherent nature and therefore it is normal that you are seeking fulfillment of that inherent longing. But the road to infinity and eternity is, as the words say, very, very long. You may never get there, unless you sit down just where you are and start thinking. You are a God inherently, but at present you are acting as a foolish human being. There is a convenient shortcut to infinity and eternity; if you have diligently followed our expositions so far, you'll know where to find it. If not, please read the past seven chapters of this Book of Ultimate Wisdom all over again. The clue where that shortcut is to find is hidden there. Rather than following the route to Infinity and Eternity you are following now, you should... - If human logic fails you now, switch on your divine brains and logic and you'll see that shortcut in all clarity. Yes, you deserve nothing less than infinite fulfillment, but where will you find it the fastest? Certainly not on the route you're taking currently as that route is infinitely long and takes an eternity to cover. Study, think, apply; then you will see clear what you are supposed to do to get the infinite fulfillment that is yours as a God. Sure, it's not that difficult to figure out. At this point we'll leave it to you to figure out that shortcut route.

### **I.7.3 I am an Expert; trust me!**

We are living in a sort of society in which our earnings come from providing services. That's the normal way of life for us. But that also means that doctors only earn, when there are sick people, manufacturers only earn, when there are people that buy, and experts opinion is directly interlinked with them earning their livelihoods. That's a very dangerous system. Whether we realise it or not, earning from providing services or research opinions suggests that we are very likely to get cheated. Ironically, in our system it is in the interest of the doctor that you are sick, as the doctor doesn't earn when you are healthy. It is in the interest of the manufacturers and companies that you purchase any junk they produce to keep their business going. It is in the interest of the clergy to keep you happy so that you don't give your donations to others. It is in the interest of our specialists to twist their researches in such ways that their sponsors are being kept happy.

How can we trust our specialists to tell us the truth, when their salary depends on them not telling us the truth? How can we trust our clergy to teach us in accordance with the relevant scriptures, when they must fear that we dump them for better options, when they tell us 'what we should hear' instead of 'what we want to hear'? How can we even trust our doctor's diagnosis, when the doctor only earns, when we are sick - and not earns, when we are well?

It is not really the people that are inherently dishonest with us; it is the system which arranges things in a way that those who are honest with us could ultimately be the losers. Everyone wants to earn and provide for their loved ones. But doing so honestly makes things extra difficult. Can we really trust our specialists to tell us what is good for us and not just telling us what is good for the business and manufacturer which are sponsoring such specialist?

That's not to say that our specialists are outright dishonest. One can also play with words and represent things in ways that make both sides happy, like in the following fictitious example. A coffee manufacturer asks a studied specialist to conduct a research whether coffee contains valuable minerals and vitamins. The coffee company grants the specialist a large sum of money to be paid out in monthly installments over a period of 12 months to facilitate the research project and to provide the specialist with an income for this period. However, there is in fine print a clause attached that the specialist will have to refund the entire sum plus interest, if the coffee company is not satisfied with the research study. The specialist, in fear of having to refund the coffee company a whole year's income plus interest, words his research in such a way that the coffee company won't have any objections. Of course, coffee growing on the field is likely to have valuable minerals and vitamins. But unfortunately they get destroyed in coffee company's processing process so that the drink in the consumer's cup no longer qualifies to be a health drink. Luckily, both the plant on the field and the liquid in the cup are called by the same term: coffee. So our research expert can safely conclude that coffee has many valuable minerals and vitamins as long as that expert does not specify which coffee; the one on the field or the one in the consumer's cup. Of course, people as the consumers will think of coffee in their cup and not of coffee in its growing stage on the field. That's not to say that our coffee company is outrightly cheating us. But in business and research projects many such loop holes exist. Can we really trust our specialist when the sponsor has to gain significantly when the specialist twists the research to keep the sponsor happy? Is the specialist to blame when the contract with the sponsor says that the specialist has to refund the entire research funding, when the sponsor is not satisfied in the end?

It is our system, not necessarily the people, that is to blame. It is our system to get paid for service, isn't it? Such system literally invites people to be dishonest with us to facilitate their own survival. This doesn't mean that everyone in our society is outright dishonest. But it means that in a society's system like we have it we have to be very, very careful whom we trust.

Then whom can we trust else than ourselves. Or are we also prone on cheating ourselves? If we are naive and believe everything that is told because it appeals to our feelings, then we are the fools who cheat themselves. And we should not blame others when we are ourselves



irresponsible and sponsor those who flatter us and tell us what we want to hear. If we make fools of ourselves with naivety and wishful thinking, then we shouldn't blame anyone for cheating us or supplying our ears with twisted truth and flattery. Everyone wants to survive and cater for their loved ones. If our clergy has cheated us for perhaps centuries, it may be that we have invited such cheating with our own attitudes. So let's not blame anyone; rather blame ourselves.

Can we trust our specialists, clergy, doctors and so on? Certainly we can't trust anyone in a society structure where we pay for service and don't pay when there is no service or need for service. In such a society structure we can only trust ourselves. That's to say that we are not so naive that we cheat ourselves by falling for sweet words and flattery, no matter how soothing and convincing. We will have to research and check everything ourselves, unless we create a society where everyone provides responsible and dedicated service without asking for pay and remuneration. Think of it; which society structure would you like to work and live in?

Here we see another big difference between Gods and Humans. Humans serve and charge while Gods serve and provide free. Have you ever paid someone for beating your heart and digesting your food that you just put into your mouth, chew and swallow? You have no control of these functions and many other functions in your body either. They are provided free, aren't they?

## **Of Divine Origin**

This Book of Ultimate Wisdom is of divine origin tailored to be studied by a severely confused world. Ultimate wisdom ordinarily is exclusively for Gods as is the legendary Philosopher's Stone, as it is ultimately the Gods that truly are interested in wisdom and not so much the human folks. We have tailored this Book of Ultimate Wisdom to help aspiring Gods to rise far above their current perceptions and become true Gods of the Micro Cosmos themselves. And, in line with divine service, this book is provided free; no strings attached and no donations invited. Please say a loud 'No' to anyone seeking to sell you divine wisdom of any kind. Serving and asking funds for such service is a human trait; true Gods always provide their services for free.

This book is an Original, not a Copy. We have purportedly excluded references to existing other works and texts. There are indeed plentiful. The eager aspiring God of the Micro

Cosmos is held to search for clues, proofs and references in its own world and surroundings.

Practical application in one's daily life here on Earth; that's the only practical way to constructively use this book.

## **I.8.0 I am a Soul**

Some religions do proclaim that human beings are essentially 'souls', but people are not exactly sure what that is. Over the centuries this subject has been researched plentiful up to exhuming dead bodies or monitoring the weight of dying people at the very moment of death, as 'soul' was perceived to be 'physical': Something that is inside the body and leaves the body at the time of death.

There is indeed something one could call SOUL, but soul is not physical nor even mental. There is a THIRD in the dual mental plus physical set up. That third is the soul.

One could say that SOUL has a MIND and a BODY.

SOUL is the EXPERIENCER that connects through a most flexible and interactive mind with the body. The body is connected with the environment of an outside world and communicates with the mind through the five senses. In a way, having only five senses available here on Earth is quite limiting for the mind. On top of this limitation those five senses are anything than perfect. The mind could easily handle ten, twenty and hundred senses. It is that capable and flexible. But being restricted to only five senses, which aren't even perfect in their sensing capabilities, the mind could easily come to misperceptions and misconclusions. Animals, for example, often have much more capable ears, eyes and noses than the average human being. But in contrast to the human being it is the animal's mind that is limited. The animal acts predominately on instinct and not on free choice like a typical human being. Having an all perfect mind the human being is equipped with only five imperfect senses. How come?

The human being, divine in essential nature but projecting physically through a body, has another tool of awareness that is inherent to divine beings. It is intuition. However most people loose the ability to use intuition early in their childhood days by focusing or being focused by their environment too much on an outside world. Toys, especially those that rattle or make music, draw the children's attention away from their inner world to the outside world. Inherent intuitional capabilities are lost that way. One such capability is 'conscience', a natural ability to know deep within in heart and mind, when one is about to make a mistake or do something one should not do. One knows that one should not do, but being animated or tempted to do something one better should not do, that conscience is suppressed often early in one's childhood. Thus the adult often lacks the ability to 'feel' the rights and wrongs and thus is forced to use existing rules and laws for orientation. But such laws and rules may not

always be conform to universal rules and laws and aren't as reliable as conscience.

### **I.8.1 Soul, Mind and Body**

The SOUL is the EXPERIENCER that uses the facilities of the MIND to connect through FIVE SENSES in the body to an outside world to entertain two way communications with a surrounding world. When a person dies, all that is lost is the body and with that the ability to communicate through its five senses. The mind doesn't die, as it is still connected with the soul. The soul-mind team can continue on its own, except that interaction and communications on the physical field are cut. But there is much more 'out there' than a field where a physical body is required for interactive communications.

Being too much focused to an outside world beyond the physical body one loses one's finer sense perceptions of the 'world beyond' and its vast options and capabilities. One is then said to be 'Earth-focused'. Such training of one sided earth focus is often embedded in the growing children's years. Parents and teachers often do not realise how much damage they do to a natural child by focusing such child eagerly to the surroundings of an outside world. Such world, of course, is the world of parents and teachers who themselves have lost the contact with their inner world at an early stage of childhood.

Do you know what does 'conscience'? That's the natural ability of the mind to tell between right and wrong. Sure, at some stage in childhood you'd experienced what is 'conscience'. But suppressing such warning signals from within we've learnt to manage on our own - or at least we think so. In the after death stage, disconnected from the body and its five senses and thus disconnected from the all disturbing impressions from an outside world, conscience wakes up again. It's 'conscience' which becomes the mind's guiding memory and in this connection mind is able to judge itself. You are your own judge after physical death; there is no God up there that judges you. You judge yourself. The SOUL, the essential YOU, or what we call the God of the Micro Cosmos, is pure and perfect in its inherent nature and ultimately the EXPERIENCER. Learning from the mind its interpretation of all the good and bad that was done on Earth in absence of an active conscience and intuition, the SOUL feels an urge to 'make up', as the inner balance and harmony of such perfect soul is imbalanced. The final judgement comes about from the need of self-balance of the soul and the soul is the ultimate judge. The God of the Micro Cosmos judges itself and facilitates whatever corrective action is required to 'make up' to find that perfect divine balance again. Forgiveness in such respect starts with divine self forgiveness of all parties involved; additionally, there is an automated

forgiveness of fifty percent built into the universal structure and system. Beyond, one will have to 'redeem' oneself in one way or another. What to do, when the body costume is gone?

## **I.8.2 Reincarnation as it unfolds**

There are various belief concepts around Earth what happens after death. We're not going to discuss them individually.

We know that only the body dies and, as the body is no more than a costume of a theatre actor playing temporarily on the stage of Earth, the True Self doesn't die. It just loses the body costume and with that the five sense ability to communicate on Earth.

Whatever 'place' we stay after physical death, be it heaven, hell, paradise or whatever human beings may believe and hope for, losing one's physical body the entire perspective changes. Being a body and world focused human being one has the typical human perspective. Losing that body and its five sense capabilities one is predominantly a God of the Micro Cosmos, also called SOUL, endowed with a mind that still lingers in past earth existence memories. But out of that perspective one also can see clearly one's entire journey to Earth through the eyes of a truly neutral judge of the universe.

In relative terms, we could say that everyone is entitled to eternal life in heaven. But while everyone has the right to be in heaven, not everyone will feel comfortable there. With a burdened conscience stay in heaven could become quite unbearable. The one who shuns the light fears the light; the one that loves darkness seeks darkness. So while everyone is essentially permitted to stay in the bright light of heaven, some may feel more comfortable in the darkness of hell. Then WHY force anyone to an after earthly life existence one is inherently not comfortable with? That's the way we judge ourselves based on the habits we acquired during an earthly lifetime. It's sort of automatic.

Similarly, there are earthly desires, dreams, and wishes that can't be fulfilled in an after earthly lifetime. One would need to go back to Earth to fulfill them. Then WHY force anyone to stay in a septic place called Heaven, when one feels uncomfortable longing for earthly pleasures. The mind yearns the fulfillment of such dreams and in absence of such fulfillment the God of the Micro Cosmos can't find its inner balance and equanimity.

It's all about inner balance and equanimity in the finals, as that's from where the entire game

started and that's exactly where it has to end. In an earthly accounting system one could say that all accounts have to be set to Zero. Both credit and debit constitute an account imbalance.

Please consider that a strong desire voiced 'by a God' can't be passed off without fulfillment.

### **I.8.3 We come with nothing, we go with nothing**

We generally know that wisdom, don't we? We come empty handed to this world and none of our wealth travels with us after death. We started with account zero and we need to go with zero, both in the fields of action and desires. Unfortunately most of us fail to watch to keep the account balanced during their stay here on Earth. Most of us leave Earth in debit, don't we?

We hear these days of the 21st Christian century people sometimes talking about 'Karma'. What is that, Karma? It is a word from the ancient Indian Sanskrit language which simply means 'Action'. One can't really have good or bad Karma; expressing things like that one uses the word 'Karma' out of context. But all Action has consequences, visible and invisible ones, and due to this world's inherent nature and structure each action has DUAL consequence.

Why two consequences? One consequence relates directly to the aim of our action, and the second consequence is of compensating nature, as ultimately we start at nothing and have to end at nothing. In other words, we are within a big circle where the starting point is zero and the end point is also zero; exactly the point where we started out from. Closing 'the loop' is often not possible during one's ongoing lifetime; so we are leaving Earth 'imbalanced' not having made it back to where we originally started out from.

Let's say, a big ship sails from London to Los Angeles via Sydney. It was a long journey and the crew and its passengers are longing to go back to London. One could take the same route back which was a lengthy one. Or one could try to navigate back to London a shorter route, wherever one finds one.

Same it is with our existence here on Earth. We've been on a long journey through perhaps a million years and never made it back to where we started out from. Some of us will be tired and wish to go home, while others still are eager to explore more. It is the ones that are longing to go home for whom this Book of Ultimate Wisdom was predominately written. For others that are still keen to travel on this Book of Ultimate Wisdom will be a valuable guide on their journey and impart the knowledge and understanding what is happening here. There

is no limit how far one would like to travel 'from home', but the further one has travelled the more difficult it may be finally to go back. That's unless one has travelled using wisdom and knows one could always find a shortcut home, like our ship above traveling from Los Angeles via perhaps Panama to London. But one would need to be knowledgeable enough to know what shortcut options exist. This Book has spoken and will speak more about that.

### **I.8.4 Is the Universe our Home?**

This Universe is no more than a huge 'bubble' floating in a much larger 'something'. We could compare that, once again, with water floating within the empty space of a cup.

If we just focus on our earthly body costume, then that's all we'll know about our 'existence'. We need to reach further. There is also a mind that modern psychology of the 21st Christian century is just beginning to discover. And then there is us, the Gods of the Micro Cosmos, that HAS a mind and a body. We need to get the setup very clearly into our heads. We're NOT the body, but we have a body; we're not the mind, but have a mind. We're, and even that only as a temporary projection from an even further field, Gods of the Micro Cosmos that one could also call Souls. Being a 'soul' is not the end of it; but for the moment it has to suffice.

Let's have a look at theatre play. There are actors and there is a costume room. And there would be likely also masks and a beautician that puts make-up. That all pertains to our earthly bodies. But the actor, who puts on such mask, costume and make-up is NOT the costume, isn't he or she? Such actor is just using them to play a role on the stage of the theatre.

There is more to explore in this theatre. What else is there? Besides a stage for the actors in costume, mask and make-up to play certain roles upon, there is also an audience that watches the play. Would you like to rather play on stage or rather be in the audience watching the play? Choice has been yours originally, but once you opted for participation on the stage, perhaps having been just somewhat 'bored' watching all the time, you're bound to complete what you've started.

What else do we find in that huge theatre? There is also something called 'backstage', isn't there? There are participants in the play that have rather indirect roles like lighting, directing and so on. And somewhere there would also be a 'screenplay' that tells the story that is currently enacted on stage. Have you ever got to have a look into the 'screenplay' of the play you're currently participating in? Certainly would be fun to know what lies ahead, wouldn't it?

It's all within your reach, as the God of the Micro Cosmos certainly knows and is entitled to know. However all focused on a human mask, body and make-up the mind is distracted and thus out of your present human perspective you can't access and know what that 'screen play' is telling.

What else is there? There would be certainly a theatre administration that pays the 'salaries' and takes care of a lot of other administrative things. And then we have the theatre building itself and within its doors to 'a world outside the theatre'. What is that world like, you may ask?

Well, it's all about 'perspective', the side or angle from which you are seeing things. The secret lies in KNOWING all the sides and their individual view points; not just your own or the one of the group you are belonging to. Sounds crazy? It isn't! You need to know 'all the sides' for ultimate clarity and understanding. Why don't you start practising that in your own world in which you're now; such practise will help you plenty to come to terms with the 'beyond' and even the 'further beyond'. Why? The main difference of a human being compared with a God is that the human being typically is single-sided and a God is multi-sided in consciousness. The human being thinks mostly 'absolute', whereas a God approaches things with 'relative' thinking.

There are five fields in the human world in which you could practise yourself in getting 'multi-perspective' insights. These are

- (1) nationality and belonging to a nation,
- (2) culture and practising culture,
- (3) class/caste/race and being 'by birth' and 'upbringing' one of 'them',
- (4) religion and religious grouping and being a member of one particular grouping by either birth, upbringing or your own choice,
- (5) gender affiliation and outlook.

You will likely quite easily and naturally associate yourself 'with your own kind'. How about 'the other kinds'? Why not muster the courage to join, temporally, some 'of the other kind' to enlarge your perspective and vision. You need to be able to have a 'multi-perspective consciousness' to embrace the higher planes that come beyond earthly existence. These five mentioned above are the 'training ground' to qualify for higher perception and insight. And you can practise those right here where you are; in your own world and surroundings. Just start with the one that is the most practical for you. One will do for the start, but ultimately you will need to be well practised and acquainted with all five. That sets the stage for you reaching 'beyond the human world and realm'. Why? You need to be able to look beyond



DUALITY and beyond the much discussed CIRCLE in which you are presently stuck. You are essentially 'stuck in your world' in mind and consciousness, until you learn, through your own change of mind-settings, to look 'BEYOND your own little world'.

## **A world beyond our Universe?**

Well, let's take again our 'own world' example. There is in our world a building that we call a 'theatre'. It's a fairly huge building with some doors leading into it. It's a totally different world inside; a world of play and fantasy. There is a theatre administration that, among others, has invited us in by some form of advertising and got us to take a seat in the audience. Having been watching for some time we've got the thought and idea that it might be so much more fun to participate 'on stage' than just watching. We likely would have gone 'backstage' to speak with the director who had welcomed us as volunteering participants and acquainted us with the play and the rules of play and participation. One such rule would have been that we can't just selfishly opt out mid-play, as it would be disturbing the overall performance, but would have to play diligently our part as long it was required. We signed for the rules of play and participation and were then led to the costume room to put on some suitable mask and costume and a beautician would have made us 'perfect'. And then our great moment came up and we stepped forward onto the stage and were right into playing. And engrossed into that wonderful play that we're all performing here on Earth we totally forgot where we came from and how we got here. Isn't it fun to be, for a change, not a God of Wisdom, but a human 'something' without any clarity of mind, so to speak. 'The Gods must be crazy', could be a fitting title for the play we're currently participating in; just that we've totally forgotten who we are and where we originally came from and engrossed into the play without self-awareness of our true nature we no longer know what we are doing'.

## I.9.0 Not knowing what 'they' do ...

We may be happy to use this term when we refer to others that, quite apparently, do not know what they are doing. But how do we feel, when someone is using such term on us?

We speak a lot of perspectives and we have identified already TWO major perspectives in our universal settings: The human perspective and the divine perspective.

Who are the ones that apparently do not know what they're doing? Is it the human being or perhaps the God of the Micro Cosmos, also called 'Soul'?

We are now entering the field of a far reaching psychological analysis that will give you, the reader, access to understanding your own existence here on Earth. So please sit back - and we mean that literally. Sit back and have a look at things 'from a distance' and don't associate yourself personally with what is being said here, as your own mind is very sensitive to this subject. It is, as a matter of fact, presently your mind's 'sore spot'. So best imagine yourself sitting comfortably on the crescent moon high above Earth, dangling your legs down from the side and observing from the very far distance what is happening down here on Earth. It is that sort of mental distance you need to emotionally follow our psychological analysis without upsetting yourself.

Okay? - Ready?

We said in Chapter 8 that you are a GOD, not a human being, that in essence HAS a body and a mind, but isn't the body or the mind. That God one fine day entered a place that one could call 'theatre' and being attracted to the play taking place on stage joined the acting team as a volunteer participant. And in that play the God got so lost in acting that he/she lost all feeling for space and time and even forgot who he/she is in reality. Wholly absorbed in the role enacted on stage our God became the one whom he/she enacted: A fictional person that only exists in the screen play but not in real life beyond stage and theatre.

Let's have a look at what has happened here from an EARTHLY perspective. One dear friend of yours, named Peter Smith, one day gets a fit and starts to believe, in all seriousness, that he is Napoleon Bonaparte. He dresses like Napoleon, he walks like Napoleon and all too soon the ambulance tums up with some doctors who coax our Napoleon to join them on a 'battle ship' they call Mental Asylum. And having arrived in that Mental Asylum the doctors are trying their best to 'snap our Napoleon out of it' and getting him to remember again that he is,

in all actuality, Peter Smith, and not Napoleon Bonaparte.

## **I.9.1 The Realities of Life**

Sure, you are still sitting patiently on the crescent moon high up above Earth, as it is not our intention to upset you, perhaps to the deepest core of your being. But it is one of the purposes of this Book of Ultimate Wisdom to clarify, in all seriousness, that, in a sense, that patient in the Mental Asylum is none else than you. It is likely not Napoleon Bonaparte that you are depicting here on the stage of Earth, but whatever you are currently displaying or what you are wholly convinced that you are is none else than hallucination of mind and an illusionary self that only exists in the screen play and 'on stage' in this Earthly Play. Likewise you are in almost the same situation as that Peter Smith that now believes he is Napoleon. You are, sorry to tell you that so frankly, a patient in an Universal Mental Hospital called Planet Earth, a hospital for Gods that have lost their mind.

Are you still sitting 'distanced' high up above Earth on your crescent moon quietly listening respectively reading - or have you jumped up in fury and are shaking your fist at the authors of this Book of Ultimate Wisdom that they dare to call you 'mentally ill'.

Please stay calm and let us explain. We said that Earth is a mental hospital for GODS that have lost their mind - and in your current self perception you are a HUMAN and not a GOD. Right? So we can't be speaking of you in such context, can we?

Please, we repeat again, this is an introspective psychological analysis and it is very important that you mentally distance yourself from what is being said here. We said that the God is mentally ill and as you are Human you can't be the one we are talking here about.

Let's go back, once more, to our Peter Smith who perceives himself as Napoleon Bonaparte. It is Peter Smith that has a mental hallucination and not Napoleon. And Napoleon in such context is only fiction, as the real Napoleon Bonaparte died many years ago. So it is not Napoleon that is mentally ill, as fiction can't be anything, but it is Peter Smith. In the same context, it is not you in your current human self perception, whatever you are currently representing here on Earth, but the God of the Micro Cosmos WITHIN you that is mentally ill.

Did we express ourselves clearly and to your full understanding? If not, please re-read the

earlier lines again, perhaps a few more times. Planet Earth is not a mental hospital for human beings, but for Gods that believe that they are human beings and are acting as such. It is therefore now your free choice to decide whether you'd rather be a dedicated human being or a mentally ill God that believes he/she is a human being. Choice is yours, of course, and the consequences arising out of such choice are yours of course, too. But please consider carefully that it may be more beneficial to choose to be a God that is mentally ill than to choose to be a human being that is mentally sane, as that God could be healed from such mental illness and then live and act like a God in sanity rather than being a human being that some day dies and has, beyond unproven religious concepts, no idea whatsoever what comes after.

## **I.9.2 Russian Roulette**

Did you ever play a game that is called 'Russian Roulette'? It's a nasty game that could end deadly for its participants. In a nutshell, one fills one chamber of a revolver with a bullet leaving the other chambers empty. One then turns the drum with the single bullet inside quickly like a wheel. Then one puts the revolver on one's head and pulls the trigger: Bang or Click! If it is 'bang' the participant is dead; if it is 'click' the participant was lucky and survived.

In a 6-chamber revolver the chances are 'one bang' to 'five clicks'. We can also play that game 'extreme' in filling five chambers with bullets leaving only one empty. Now the chances stand 'five bangs' to 'one click'. One would have to be really very lucky to survive playing 'Russian Roulette Extreme'.

How about playing such game putting your life carelessly on the line? Sure, no sane person would do that. And still, many people on Earth are playing 'Russian Roulette Extreme' with their future outlook, when it comes to 'religion'. By human conviction, thinking absolute and not relative, only one of those many religions practised on Earth could be the right one. If it is true that betting on the 'wrong religion' lands one in hell, it is utter insanity to blindly follow someone's teaching in pure belief. Some teachings may be humanly more appealing and others less, but who is the guarantor that it is the right religion? Aren't we playing 'Russian Roulette Extreme' in such cases hoping that some saint or savior will make sure that we get to fire a 'click' and not a 'bang' into our own head?

If we choose to our earlier question, in this instance, to be a human being that is sane, but

doesn't know anything about its existence on Earth beyond unproven belief concepts, then we choose playing 'Russian Roulette Extreme'. Chances may be 5 to 1 that we land ourselves in hell.

If we choose, however, to be a God, though that God being mentally ill at present, we may temporary 'doom' ourselves completely. But that God could be healed from its insanity and then would be able to see for itself, in all clarity of mind, what is really going on and how to structure one's life on Earth for the best outcome in the finals.

For those who wish to be Gods and be healed from that mental insanity we'd recommend you keep reading and re-reading this Book of Ultimate Wisdom and, even more important, applying in your daily life right here on Earth what you are reading. Without practical application your mind will not recover from its present state of insanity. So application is a must. Your own experience will show you the way and ultimate realisation is automatic, if you diligently follow through and don't give up. Remember, inherently you are already the God of the Micro Cosmos, also called Soul, that has a body but is not the body, that has a mind but is not the mind. So it is you in your inherent Soul State that is supposed to be in control of both body and mind - and not the other way round in that body and mind are dictating the terms. Off we go ... and a heartfelt 'good luck' and 'goodbye' to those that prefer to play 'Russian Roulette Extreme' with their lives and futures here on Earth and the hereafter.

### **I.9.3 Belief, Trust, Faith**

Once upon a time there had been a simple person, who, wandering around in far off lands, had come across some very uplifting teachings. Thrilled, such person rushed to its native lands to teach family and friends. But they just ridiculed that person and called that person 'mad'. What the people of such person's land didn't realise was simply that such person was not only talking, but had actually practised what he/she was telling and had derived its own self-realisation. What was being taught here was not just a new belief concept, but facts that everyone could simply prove unto themselves.

It is very difficult to teach FACTUAL TRUTH to others that did not have had their own self-realisation yet. In the early stages one starts with belief. Belief is no more than an assumption that something 'could be' right or true. Unfortunately, in the field of religion many people start with 'belief' - and here the story ends. 'Belief' in its own is not the end; belief needs to be put to the test - and that's where most people rather play 'Russian Roulette Extreme' than

checking out their 'belief'. We are not saying that initial belief, in absence of any practical proof, is wrong. What we say, is that 'ending with belief' is wrong. One needs to end with knowledge.

Obtaining some practical knowledge from 'application of one's belief' we may get to a stage that we can TRUST our belief concept. TRUST means that we have already put our belief concept to the test and CORRECTED a few things that we found to be incorrect. Such incorrect ideas may be not necessarily a wrong belief concept, but could be also an incorrect understanding from our own side. Important in such development is the courage to adjust one's understanding, if not the belief concept itself, rather than BLINDLY clinging to it. The stage TRUST simply signifies that we have worked with the initial belief concept and we have filtered out our own understanding, an understanding that is more to us than just blind belief.

Faith is the power of the soul to firmly believe in something that has been understood by one's own investigation, application and self-realisation. Faith isn't blind; faith knows, at least intuitively, if not factually.

Unfortunately many people on Earth mix up the meanings of 'believe', 'trust' and 'faith'. It is true that 'faith can move mountains' and if you really have faith you 'can walk on the water'. Such faith indicates that you have full trust into your own abilities of a God of the Micro Cosmos. Alas, the slightest doubt in such context could see you drown. So don't try dangerous stunts thinking you've 'reached'. And a person walking on the water is no proof that one has reached, as such means as mass-hypnosis could have been employed. For one thing, a true God of the Micro Cosmos will never put to show its accomplishments. So if you observe someone walking on the water or portraying other unbelievable stunts for the entertainment of the crowds be sure that such person isn't a self-realised God of the Micro Cosmos.

Miracles are a dangerous piece of fabric to an aspiring God of the Micro Cosmos. Miracle-Power is a dangerous distraction. One should stay away from such powers. Of course, past friends and even critics may be awed and accept the new savior or prophet in their midst. Such was also the notion of our friend discussed above at the starting of this chapter. But miracle powers have a different effect on the human mind. When the 'saint' heals one, then why not all? Healing some and not all is unfair, isn't it? So in healing some one might make 'some friends' but offend all those that one doesn't heal. And healing too many one 'offends' the professional doctors and pharmaceutical industry that lose their customers. Our friend in the story was unaware of all that and proceeded with miracles after the initial rejection by the

people of his/her country; partly to prove itself as a true saint and prophet, partly out of compassion for the suffering people. But such goodwill backfired and soon there were more enemies than friends. Having acted, though, in good faith, a solution to the problem was at hand in our friend staging its own public execution. Those who witnessed this execution had seen it happening and would swear on their own life that our friend was dead; while our friend returned to those far off lands to live happily ever after and likely a bit wiser.

We, as human beings, are quick to believe when something happens or someone acts in our interest. Religions that proclaim everlasting dreams of humanity have many followers. But having so many followers doesn't render such religions true and correct.

For clarification's sake: It is not in the interest of the Author and Creator of this Universe and Cosmic Play that its participants are helped by the means of miraculous powers of any individual. But it is in the interest of each individual to realise itself as a true God of the Micro Cosmos who is capable of helping itself. And if there is a 'prophet' or 'savior' that adhered to such miraculous powers plenty, it doesn't say that such person was a truly self-realised God of the Micro Cosmos at that stage. Such person may have been 'on the way' to become a true God of the Micro Cosmos, had learnt from its mistake and eventually understood itself as the one who he/she really is and why application of miraculous powers was out of place and why 'punishment' in a self-styled execution was necessary. But for those who benefited and who witnessed such execution the story would have been an entirely different one. Such is the effect of blind belief that doesn't investigate thoroughly the entire subject. One will need to be able to see and understand what 'had happened here' from all angles and not just out of a self-focused human perspective.

## **Faith**

If you have the faith that sees you, in private and without any audience, walk across the waters of a lake or stream, then know that you are a strong in faith. But if you then go out and brag about your feat, you are none else than an ordinary human being that is still eager to get praise and administration from the multitudes. A true God of the Micro Cosmos doesn't portray itself as such.

## I.10.0 What is in it for ME?

A valid question: What is in it for me? Why should anyone go through the hassle of studying this Book of Ultimate Wisdom and practise its suggestions and teachings, when there is nothing tangible to be achieved for oneself.

Let's go back to the story of Peter Smith in Chapter 9 who envisages himself erroneously being Napoleon Bonaparte. Let's rephrase our question in the same context to read: What is in it for Napoleon Bonaparte, when Peter Smith snaps out of his mental hallucination?

You sure can answer that question yourself, can't you? Then what is there for Peter Smith to gain? Napoleon being hallucination of mind has nothing to gain; but Peter Smith has everything to gain.

Same goes the conclusion for your own situation. You, in what you perceive presently being yourself, have nothing to gain, but you, in your natural state of a God of a Micro Cosmos, have everything to gain coming back to senses and knowing what is actually going on.

Ironically, in the mental-delusive state Peter Smith is helpless. Help can be provided by an outside person or by the hallucinatory Napoleon itself. In such case Peter Smith is the patient and the outside person the doctor. Or, in an action of self-help, we let Napoleon be the doctor.

In the same context, the God in you is the helpless patient that needs to be cured. Doctor could be an outside person or your present self, if you can accept yourself in that role: The imaginary self cures the real self.

An outside person being the doctor might say to Napoleon Bonaparte: "Honored Sir, we know you are the greatest around here, but there is a God 'up there' named Peter Smith. This God, Peter Smith, you shall alone worship and discuss all your intended ventures with." And as Napoleon diligently worships that God Peter Smith, eagerly and devotionally, Peter Smith eventually might come back to senses again.

Can the imaginary self in you handle that itself or do you need an outside person for that?

In a practical approach the 'true doer' is the God of the Micro Cosmos in you. So you should accredit all your actions to that God in you, both good and bad actions. And as that God is the true doer of all actions, that God is also the sole recipient of all 'fruits of action', both good



and bad. And if that God in you did something that invites 'punishment', then the God in you gets punished. Though you may be feeling the heartache and pain as yours, acknowledge to your mind that they belong to the God in you and not the hallucinatory self that you are still identified with. When praise is due, don't selfishly claim it for your present hallucinatory self, but humbly delegate all praise and award to the God in you, in the same fashion in which you delegate punishment, heartache and pain to that God in you. It is important that you no longer do anything for yourself, but all for the God in you. Sure you can handle that, can't you?

### **I.10.1 I am God**

Advanced Psychology! Who am I? In the present situation Peter Smith is not Peter Smith, but in his own mental conviction he is Napoleon Bonaparte. Though for an outside person both are the same as they use the same body, mentally speaking they are two entirely different ones. That's the psychological clue. As they are two, mentally unaware of each other, one can easily play a mental psychological game of communication. Napoleon, fiction perceiving itself as real, talks with God Peter Smith. Peter Smith, factual real but unaware of that fact at present, is now the fictional God that our Napoleon worships.

Could Napoleon say in this instance 'I am Peter Smith'? Sure Napoleon can't. It's the other way around. Peter Smith is (plays, pretends to be) Napoleon. In the same context never come to the wrong conclusion that you are God. You aren't! It's the other way around: God is you!

In human logic saying 'I am God' and 'God is me' are the same, but in divine logic they aren't. It is correct to say 'God is (plays, pretends to be) me', but it is incorrect to say it the other way around. That is, because God is real and you are fiction, whereas you are presently still seeing things the other way around firmly believing that you are real and God is fiction or someone 'up there' in whom you believe or whom you worship in some way. That 'God up there' is right within yourself; up there in your head, so to speak. So make it a habit to start talking and sharing with the God 'up there in your head' and intensify that process in such manner that your mind snaps out of the idea of being you. It is a psychological healing that is required here and not a physical one. Knowing and understanding the 'values' of the God and living them in your daily life will be of additional help in this process. Upmost, however, is the fact that there must be nothing in your life more important than 'that God up there'. If there is, you'll be tied to your illusion of being a human being and your mind won't 'snap out of it'. Where to find the clues and the values of the God? Try the scriptures of your religion; perhaps you understand now why they were given to you. Those scriptures teach

recommendations and commands; they don't give the actual reasons. Now, perhaps, you'll understand WHY they were given and what's the story behind all those injunctions: To snap you out of your erroneous belief that you are a human being and help you to claim again your true nature of a God; a God of the Micro Cosmos in this case.

There is also a God of the Macro Cosmos 'around'. You can help yourself in that development process by referring to the 'God up there' as the one in your own head and to the 'God around you' as the one of the Macro Cosmos, of which you, even as a God of the Micro Cosmos, are an inherent and integral part.

You may need to re-read and study the foregoing lines a few more times till the message sinks in. It is high psychology, none else, and all that you need to bring around is a psychological change in your own perceptions. Try to come mentally to terms with the difficult to understand fact that 'the God is me', but that this doesn't work reciprocal as 'I am the God'. The 'I' here is fictional and fiction can't be 'something'. It is only when 'fiction' is capable of giving itself up, wholly and totally for the 'other', that mental healing takes place. In such context the fictional idea of 'me' has to 'die' to awaken (snap mentally out) the 'God up there' from its incorrect perception. The 'God up there' alone is real and the 'Me down here' is fiction, in the same context as 'Peter Smith' alone is real and 'Napoleon Bonaparte' is fiction. It takes a lot of mental awareness practice to actually come to terms with that so simple fact and truth. The mind, once incorrectly programmed and trained, finds it painful to change deeply ingrained perceptions, even if they are incorrect. In the same way as you and society, per chance, have brainwashed you into a certain pattern of thinking and understanding, in the same fashion you need to re-program your mind. Affirmations help to some point, but ultimately only 'forgetting the presently perceived Self' in serving 'the God up there' will do the trick. The hallucinatory Self, the present 'I, Me, My, Mine' have to 'die' in selfless service and surrender.

### **I.10.2 Relative versus Absolute**

As you struggle, and yes, it is a big struggle, to 'awaken that God of the Micro Cosmos in you', you may take heart from a simple 'universal fact and truth': If you succeed to only develop the God in you to 50%, that's to say that you can be in your nature and behavioural patterns half God and half Human, then you will get deep divine insights as you will be able to see and understand this world and universe from two sides: both the human and the divine one. Having two perspectives to view from, many things will become 'clear' to you.

### I.10.3 Need help?

Can you be your own psychotherapist or do you need an outside person for helping you? In the beginning it sometimes helps to mix with like minded people around a qualified teacher. We call that 'group-therapy'.

It would actually be the role and duty of the various clergy of the individual religions to give you the helping hand to develop the BASICS for your great journey of self-exploration. You need a sound platform to stand upon to take off. Unfortunately such clergy has made themselves often financially dependent on their students and now rightfully fears for its livelihood. What if they tell the students something that is not to their liking. Centuries ago it was quite common practise on Earth that religious beliefs, whether right or wrong, could be enforced with 'the power of the sword': Follow the belief or die! Times have largely changed since then and, with only a few groupings remaining on Earth that still enforce religion with threat to life and freedom, the priesthood and clergy has to make sure that religion stays 'attractive' to the followers. In such fear of not sufficiently pampering the followers the clergy might use 'convenient interpretation' to appease the people. Blame the clergy? Not really, it is the followers that are often to blame for innocently and ignorantly blackmailing the clergy. The practice of giving donations can be turned into an indirect blackmail campaign, when devotees 'declare' their donations, perhaps in form of asking a receipt for tax purposes, rather than just putting the funds quietly in a donation box with no one knowing who and how much was given. It is often the people that want to be 'recognized' for their generous contributions and thus unwittingly 'buy the favours of the clergy', who will then feel emotionally and psychologically obliged to pamper and flatter 'such generous donors'.

It is YOU that needs help in the initial self-development process and you would be ill advised to blackmail and influence your clergy-teachers in any way that makes them feel 'obliged' to you. Otherwise you may be fed with the wrong, incomplete or interpreted information that makes your heart happy right now, but won't serve you well in the long run. So please don't blame the clergy for not telling you the entire story; better check and blame yourself, first, for perhaps unwittingly blackmailing them.

When the student - teacher scenario is set up properly, the teacher will provide the student with all the required knowledge and information that will help the student to cover the initial 20% of the journey. The good teacher will also encourage the student to ongoing and regular practice of what has been taught and learned. But then the teacher will have to let the student go on its own staying itself in the background and supporting the student only from there.

Unfortunately, some teachers get emotionally attached to their students or students get emotionally attached to their teachers and group participants or both. In such case teacher and student are 'worshipping' each other rather than 'the God up there' in their heads. Always remember that God is the goal and not your teacher, clergy, congregation and whatever else you might get attracted to on your journey. Never let 'anything else' become 'a God before the Lord'; not even your teacher, group or religious organisation. In the correct setting the student will faithfully and honestly follow its teacher without ever trying to financially blackmailing its teacher and the teacher will thoroughly guide and train the student and let such student move ahead when the student has mastered the initial 20% of a perhaps longlasting journey. Students may sometimes incorrectly think that they have mastered the initial 20% and wish 'to take off'. Going off on one's own too early will usually result in the student falling back into old patterns of lifestyle and behaviour without realising it. The mind settings are the one's that need to be changed; not the body. And as the mind is a slave to 'habit', it could take up to ten years of continuous training and exposure to the proper values and ways to successfully reprogram the mind so that it won't fall back into its 'old ways'. So don't think too soon 'you've made it' and rush off on your own. Mental training and change take up considerable time, especially to establish a solid 20% platform foundation from which you then will 'take up the long journey' on your own.

Self-training right from the start is a viable option in an environment that is not suited to free religious self-development, such as dictatorial religious and atheistic forms of government and state. One must move with great care and often in the hiding with much discretion. In an environment, steeped in dictatorial ways, even friends and family may not tolerate anyone moving out of the 'flock' and will be eager to pull you back down to their own ways. Remember, you can't help anyone else in your initial training years. Don't share great realisations and discoveries with anyone or risk being ridiculed and exposed in society. If you decide or by circumstance are forced to move on your own, remember, you likely will be on your own for many years to come. You can't change others before you have thoroughly changed yourself and even as a Master you'll find it very difficult to get genuine and dedicated followers. Thus is the power of habit in the subconscious mind of environment and society. Remember that 'normal' or 'the norm' is always what the majority does and believes in and not what objectively is right and correct. Don't allow others to pull you down to their level by trying to teach them anything or share your wonderful experiences until you have been yourself for at least twenty years non-stop deeply engrossed into your self-development journey; and even then it might be still too early. Remember that a true God never shows off to others or uses divine knowledge and information for self-gain practices of any kind. As long as you are bound, in yourself, by habit or by the law of action (karma), you aren't free.

### **I.10.4 I believe in my 'Savior'!**

Whosoever you have chosen as 'your savior' in your life, that savior can't save you against your will nor without at least some practical participation from your side. People have misunderstood the term 'savior' with the term 'life saver' that might rescue drowning people from some lake or ocean. The 'savior' is bound by divine law and regulations and if he/she is a genuine savior he/she will abide by those rules. In a nutshell those rules comprise, among others, that you've to put forward at least 50% contribution of your own in the 'saving process'. As guidance is given by the savior in 'how to proceed' with such process one could say that the remaining 50% of self-effort are equally divided between savior and the one seeking to be saved. That ultimately amounts to 25% self-initiative, 25% guided effort and 50% that are already woven into the structure of this universe; some people call latter the 'grace of God'. So please don't depict your savior like a common life saver you might find at a beach or swimming pool, who pulls you out no matter what; your own constructive effort is needed in the universal 'saving process'. That's unfortunately 'the rules of the play', which you've signed when you volunteered to participate in this universal play, though you might not remember that anymore.

### **I.10.5 I have 'my Guru'!**

A 'Guru' is a good thing, if you can find a genuine one. Not everyone that claims to be a 'Guru' actually is one. The word 'Guru' derives from ancient India and describes the Guru as someone that has 'been saved' him/herself and now is capable to help others. It is not of much use to ask anyone that is still ignorant to guide and teach, as an ignorant person doesn't know itself. A person tied to a tree can't untie another person who is untied to some other tree. But a person that is no longer tied to a tree can untie you. You might want to interpret such example as the 'Guru' being a 'savior' like people hoped for in the previous chapter 10.4. That's not correct. You'll need to participate in the process of 'untying' same as explained in the previous chapter 10.4. In a sense, the term 'Savior' and 'Guru' stand for the same. The Guru is your 'savior' as he/she guides you how to proceed; but actually proceeding is your self-effort. Same goes for your chosen 'savior'. The 'Savior' is your 'Guru' in as far as that Savior guides you in your 'saving' process. The confusion of terms comes from people commonly thinking 'absolute' and then coming to an 'absolute conclusion'. Neither 'Guru' nor 'Savior' are absolute; that's wishful human thinking. Both 'Guru' and 'Savior' are 'relative' in them providing you with the much needed guidance and your own self-effort is needed then to pull through along the guidelines given. Does that clarify this point?

### **I.11.1 Ignorance leads to Confusion**

There was, once upon the time, a saint who spoke of God as his Father in Heaven. He did so to show to people that God is Family, loving and caring like a Father, but also just and fair in dealing with its human children. Unfortunately, people mistook such quote to reason that God is male and started depicting God as an old man with a long white beard. Such can be misconception based on ignorance and confusion. Of course, God isn't male or female. Gender is an attribute of the human body and even the God of the Micro Cosmos is inherently neither male nor female. One could say, that the God of the Micro Cosmos (also called Soul) adopted a male or female body out of its own choice for practical reason. But that body in such context is no more than the mask and costume an actor puts on in a theatre play; it's temporary and not a permanent outfit.

That saint made a few other statements that have kept the minds of the human beings busy for centuries; we just would like to comment here and not interpret. There are some vital facts not known to the human beings that need to be considered in such context.

Beyond that statement of 'My Father in Heaven' that saint proclaimed that 'My Father and me are one' and 'Nobody comes to the Father except through me'. People used such comments to reason that that saint is God himself. Sure, he is a God, like everyone on Earth is a God. The difference between that saint and the human folks was simply that he had figured out such truth, while his human followers still believed they were human in their inherent natures. Every human being is a God, a God of the Micro Cosmos (also called Soul), who is closely connected to what that saint called 'Father in Heaven'; what we call 'God of the Macro Cosmos'.

Let's go back to our example, shown in an earlier chapter, of a number of vessels being placed at the ocean shore and one by one being filled with ocean water. That's the connection we human beings have with the God of the Micro Cosmos, the water inside the vessels of our human bodies, and with the God of the Macro Cosmos, the water in the ocean. In such context we can approach the subject from two sides or perspectives. How do look things when we look at them from the human side and how do look things when we look at them through the eye of the God of the Macro Cosmos?

In such context one could say, that the ocean, being the source or origin of the water in the vessel, is the 'Father'. What is then 'one with the Father'? The vessel is not one with the father, but the water inside the vessel, the God of the Micro Cosmos (the soul), is one with the ocean.

The mistake we human beings make, repeatedly and continuously, that we associate our existence on Earth with our human bodies and not with our inherent God-nature. That leads then to plenty of misconceptions and misunderstandings. We are in our inherent nature children of the God of the Macro Cosmos, children that have been endowed with the mask and costume of a human body. But we are not that body! We are Gods that participate in a **PLAY ON EARTH**.

What does it mean then to say 'Nobody comes to the Father except through me'? It simply means that we have to self-realise ourselves to be not human bodies but Gods of the Micro Cosmos. The God of the Micro Cosmos can state, in truth and earnestness that 'the Father and me are one' in the same manner as the water in the ocean bed and the water inside the vessels at the ocean shore are one and the same water. And we are not talking here about blood and tissue liquids. We are talking about the essence of our own nature that human beings largely have not figured out yet and therefore likely have not coined words or terms to describe it other than 'Soul'!

When one is, in consciousness, identified with one's true nature, one also speaks out of that perspective or viewing angle. Bystanders, however, see only the human body that is addressing them through the mouth and associate the speaker with the body. Thus the misconception of the 'body and God being one' and 'nobody comes to God except through the person circumscribed by the body' is created. One needs to know the big picture to understand such statements from the side of a saint. A true saint is self-soul conscious when acting and speaking and doesn't perceive itself as just a mortal human body.

### **I.11.2 Confusions of Mind**

The mind is a tool in that it conveys messages from the body to the God of the Micro Cosmos participating in a play on Earth. The body, the inherent mask and costume for such play, is endowed with five senses that convey messages to the mind. The mind in such context is the interpreter of such messages. The mind perceives whatever it wishes to perceive, even if it is incorrect. It is not difficult for the mind to misread messages. It is therefore vital that we feed our minds with the correct information. Beyond, we should never mis-program our minds to interpret things as we wish them to be interpreted. Doing so renders the mind simply stupid.

It is important that we remind ourselves, from time to time, of the 'big picture', so we don't lose ourselves in small things to a point that our mind gets confused. Once the big picture is

clear in our mind, with regular reminders, it is much easier for the mind to deal with the constant stream of sense information coming in without getting confused. And what is the big picture? We just have talked about it: We are, at present, Gods of the Micro Cosmos that participate in a Play on Earth in our brilliant masks and costumes, a Play that is subject to certain rules and regulations that we should keep in mind. Beyond there is a God of the Macro Cosmos who could be seen as the Author and Director of the Play we are participating in. We are all volunteers to the Play, but having started we need to continue to play and can't just dump everything and simply walk out of it. We need to complete what we have started and failing to do so is subject to retribution. Such retribution we will award to ourselves once outside our distracting human bodies. So we better carry on, to the best of our abilities, and successfully complete what we have started. Suicide is not an option to quit that Play.

Sure, we love to mislead, even cheat ourselves from time to time, to portray ourselves as 'good people', either in front of others or in front of ourselves. Here too, we need to see the big picture and not just see the small one that suits us for the moment. Innumerable are the examples to that; here just a small example. In some walks of life it is and perhaps has been customary for a while, to release animals, which were captured, back into the wild as a good deed of ourselves. We might go to a shop and pay the trader a sum of money to buy a flock of birds that we then later release into the wild, perhaps as an integral part of a religious ceremony. That makes us feel good about us; sure it does! But what we tend to overlook in such case is that those birds were captured, in the first place, to facilitate us releasing them. When the trader knows there is someone buying birds in large numbers, the trader will make sure the customer stays supplied and captures even more birds. In such context the animal is put through unnecessary fears and sufferings to facilitate us doing a good deed. We need to think the whole story from the start to the end and not just our part of releasing the poor creatures again. One needs to see the big picture and not just the little one that concerns us that very moment. The most effective way of 'releasing birds or other animals into the wild in the context of doing the right thing' is not to capture them in the first place. When the trader that catches those birds or animals doesn't have any customer, then such trader will go bankrupt for lack of us buying these animals. Without customers there is no point to continue such perhaps thriving business. We may perceive ourselves as 'good people' releasing those creatures to the wild, but we certainly would be much better people when not facilitating such games in the first place by our participation.

Similar goes the story for beggars these days. If we would be willing to share, there wouldn't be beggars in the first place. We create beggars in our societies by willfully pushing others aside and out in our own greed. The effective way to help beggars is to let them participate and share in our ventures. Those who are simply lazy and for such reason don't want to



participate and share will be beggars out of their own choice; we need not support those...

### **I.11.3 The best Citizen in the best Form of State**

There have been various forms of state over the centuries and millennia and we will not discuss them here, as they all failed ultimately. What we will talk here about are the people living in such forms of state. It's the citizens in a state that make the difference and they are ultimately responsible.

Dictatorships have come and gone, monarchies, communism and democracy. It never worked. People have blamed their rulers and were unable to see that they themselves were the ones to blame. Whatever form of state one employs, whatever its pros and cons, whatever social security and medical facilities are involved, in the end things boil down to the individual being a self-responsible citizen.

Corruption starts with the individual and not with the system. That individual that sees itself as the first and foremost person in a society, catering for its own needs first and foremost, likely is also the most corrupt one. It all starts with us and it all ends with us. We need to learn to see us as 'one kind of people' here on Earth. We must understand that no form of state will ultimately be workable, if we are irresponsible ourselves. Corruption starts with us; not with the authorities and rulers. If we blackmail our democratic governments with our vote in lieu for favors from their side, then we must not be surprised when our governments become corrupt. And when in a communist system we become simply lazy and always find the easiest way out of doing our duties, then such system is not going to work, either. And if we bribe our monarchs with flattery, then we must not be surprised when they abuse their power. It always starts with us, the individual citizens in a state. We are the one's ultimately responsible for the actions of our rulers, as we placed our rulers in such powerful position with our votes. Thus responsibility also extends to Universal Law, the laws of the Universe. We may get punished for the crimes committed by our rulers, even if they abused their powers; we are not entitled to claim innocence, when we placed our rulers in such powerful position at some time, perhaps in the course of a democratic election. Ultimately it is us all responsible under Universal Law.

So don't blame 'a God up there' that is punishing us; we must find the faults with ourselves.

### **I.11.4 Who's the Owner anyway?**

Who created the world we live in? We sure didn't, though in limited ways we did. The basics were 'provided' enabling us to build cities, towns, homes, streets and parks. Using the provided basics we were also able to convert such basics into other things like oil into plastic. We learnt to process and give shape to metals and other natural resources. But the basics that we use for all that are not our creation.

We create children by using existing processes of life and nature. We may even be able to create human bodies or parts of it using something that is already there. But we never start from 'nothing'. We always start from 'something' at least.

The one that can put forth something out of nothing is truly a creator. The rest are only relative creators, as they don't create right from scratch, right out of 'nothing'.

Only the one that can create something out of nothing can claim to be its owner. All others can only claim that they have created something out of something that was already there, even if it looked and felt different. Can you create something entirely new, right out of nothing, which is not further development, conversion or derivation of something that was already there? If not, you can't claim to be the owner of what you created.

For centuries people have claimed to own land, countries, homes and so on which were not creations out of nothing, but which were already there, if not in actuality, so still in the basics. You may have printed money, but the material you printed on came from nature or other natural resources. You may have found gold, silver, iron ore and other items, but you only found them and did not create them. As long as human beings can't create something entirely new without using anything, even in the slightest basics, that was already there, they can't claim ownership. We come to Earth with nothing and leave Earth with nothing. Whatever we say we own, we own only temporary.

Then why ruin our short time on Earth with senseless greed, when we can't be the ultimate owners anyway and have to leave all behind, when we die?

## **The Purpose of Life**

Everyone is born a human being. Contrary to the claims of some religious organisations no one is born a 'God'. It is the goal and purpose of life to develop the God out of an existing human being, out of oneself. One needs to be a God in thinking, feeling, understanding and acting. Those who have achieved such goal can truly say 'My father and me are one'; all others still need to learn to develop and express their inherent divinity in appropriately divine ways. Serving and helping others is a great way of becoming a God. But such service and help must be entirely free from all selfish motives. Here we find another important difference between a God and a Human: The human is generally self-focused and does everything or almost everything for itself and for personal gain of some kind; it may not necessarily be monetary. The divine being serves free without any claim of reward or benefit for itself.

We wish you that you all may learn to be truly divine beings and thus fulfill the purpose of your visit to Earth. All those that fail in that endeavour will get fresh opportunities to try again. Heaven and Hell are here on Earth. The realms beyond this Creation are reserved for those who proved themselves as True Gods under Earthly circumstances.

## **I.12.0 Reward and Punishment**

There is no such thing as REWARD AND PUNISHMENT in the Universe. What human beings perceive as such are 'consequences' and not 'actions'.

It has been customary among humans to reward and punish each other for millennia. As such people have grown to regard unwanted or uncomfortable consequences as punishment and wanted or comfortable consequences as rewards. The Universe doesn't function like that and there is no God up there that bestows reward and punishment.

We enter now the difficult subject of Universal Balance and consequences that derive when such Balance is disturbed. It took perhaps a billion solar years till Earth and the Universe around it had developed, meaning reached a suitably balanced setting, that made human life and existence as we know it these days in the 21st Christian Century possible in the first place.

Though the world around us appears to be huge compared with Earth and the living beings existing on it, the Universal Balance is a delicate one and small disturbances could yield disastrous effects. Unfortunately human beings have been ignorant to such simple facts and have disturbed already such Universal Balance a number of times in the past and received what they called 'punishment from God'. It was not a God that punished them, but they invited such ill consequence themselves by inappropriate actions, in a sense meaning 'they punished themselves'.

### **I.12.1 What is Balance?**

Balance is a state where all the forces in the play are equilibrated in such a way that some 'state' is created. Balance, in such context, is relative and not absolute. One could say that in a certain balanced state the human being perceives itself as 'healthy' and when such state is disturbed, the human being calls itself 'sick'. If the state of 'sickness' is not addressed within some period of time, the body establishes a new state of balance in the 'sick state'. Though the human being perceives itself as 'sick' in such state, the mind regards such state as the 'normal' state and refuses to budge, when one then tries to heal oneself. It is therefore mandatory to address sickness as soon as it occurs; not attending or postponing it by giving suppressive medication the imbalanced state of sickness becomes the normal state for body and mind. In other words, the forces of nature have equilibrated each other in a way that the state of sickness is the balanced state and to become well one would have to disturb such balance.

## **I.12.2 The Balance of the Universe**

Our Universe with all its galaxies and solar systems is currently in a balanced state that facilitates 'life on Earth'. As our Universe is in motion and not stagnant, such suitable balance won't exist forever. But as the time frames of the Universe are much larger than the average human life span, the suitable conditions for life as we know it these days are going to last for quite a while, except if we ourselves set out to disturb such excellent conditions with our own actions.

It is necessary here to explain how our Universe functions. We need to understand terms like 'equilibrium' and 'balance', 'duality' and 'trinity', 'relative' and 'absolute' as well as 'linear' and 'circular'. We have tried to explain some of these terms in the preceding lines and chapters and it is vital to understand what is the difference between a human and a divine being in thought and action. You may wish to track back through the past lines and chapters to acquaint yourself with the basics, before moving on to our scientific part of this Book of Ultimate Wisdom. The science is a very simple one, but not knowing the basics and without some basic understanding it can be very difficult to deal with even the simplest forms of Universal Mathematics. Remember, the message of the legendary 'Philosopher's Stone' is, though very simple, of divine structure and wisdom and therefore may contradict all human yearning and striving. The human being yearns for gold in physical form, whereas the God yearns for golden wisdom. One can't create physical gold with the legendary Philosopher's Stone as some alchemists are hoping and dreaming. Golden Wisdom leading to ultimate knowledge and understanding is the treasure of the Philosopher's Stone. But to understand the Philosopher's Stone one will need to have mastered the basics shown in the preceding lines and chapters, which are the basics to divine thought and action. So please don't miss out on that; or else you won't understand much of what is now going to follow.

## **I.12.3 The Effects of Imbalancing the World around us**

These early years of the 21st century human kind is faced with a fairly new problem that is called 'global warming'. Luckily, we have grown to be aware that we are the culprits ourselves and that this is not the ill action of 'some God up there'.

What has been driving our world into a state that we are now self-destroying our own living space? We have been greedy, haven't we? We wanted ALL AT ONCE; not wait for things. The practice of animating banks to give out 'loans', speak 'hard cash', to those who are poor so

that they can go shopping right here and now, has led to mass production of goods. Many of those produced products, besides the manufacturing places themselves, are polluting our environment; that's effectively the world we live in. Having been greedy, both the manufacturers for money and the consumers for goods, we created an imbalance in nature. That imbalance now creates problems. Nature around us, similar to our Universe, had been in a delicate balance that facilitated our very existence here on Earth. We have managed to disturb such delicate balance and now nature responds. There is no one in that process that is 'punishing' us; please delete such word from your vocabulary. The forces of Earth and Nature are harmoniously interwoven in such a way that if one component is disturbed all others are disturbed as well. And Earth, being an inherent part of our solar system, having been disturbed by our own actions, is interwoven with the other planets of our solar system and beyond with the Milky Way Galaxy and further beyond the entire Universe. It is very difficult to foresee what damages we have done to our Universe overall with our inconsiderate actions. We need to rectify, but how? We have created 'systems' that can't be changed overnight. What has us taken some 50 years to create may take some 50 years to uncreate again. Will nature give us that much time to rectify again what we have managed to disturb?

Ignorance is a big problem and ignorantly we err and then are faced with 'consequences'. It is therefore mandatory to remove ignorance. Once we KNOW THE FACTS and no longer hope or believe, we still have the freedom 'to act as we please', but then we won't get surprised by consequences like the kind we are facing these days. Removing ignorance and creating knowledge is therefore our foremost duty in life. We would go as far as to recommend that all schooling and educational training should be free of cost in all human societies and to be a farmer one should have studied that field thoroughly. Traditionally, people have valued each other in terms of high and low, which has been the cause of castes and classes. But the farmer that grows the food is equally important as the king that protects the country; lest the king will go hungry. When one studies those scriptures that speak of castes or classes carefully, one will notice that they did not introduce a rating by value of person, but by suitable lifestyles best for performance in the chosen trait. Some people need more muscular power for their work and others need more thought for their work. Nutritionally, what is good for muscles may not be good for thought and vice versa. That was, what those scriptures wanted to emphasise upon and not social rating. As Gods of the Micro Cosmos we are all EQUAL to each other; equal participants in the same play, lest the absence of a single side role player disturbs the overall presentation and performance of the TEAM. Everyone is equally important!

## I.12.4 The Need for Greed

What is it that make us so greedy? Why we deliberately disturb the harmonised forces of nature and cause an imbalance that could facilitate our own annihilation?

We are greedy for 'everything', as we are inherently Gods and not human beings. Being a God means to be 'everything' and being a human being means to be 'something'. In our own self-analysis we strive to be something and something more and something more. We want to excel, be recognised, be famous, be admired and so on.

Unfortunately, we haven't figured out yet that we are moving in a huge circle of perhaps infinite diameter. We still erroneously believe that we are running linear from a start to an end. We see birth and death as the entire story; we know nothing else beyond and what we 'think' we know, largely derives from blind belief concepts for which we don't even have the slightest proof. Birth and death are not the entire story nor are heaven, hell and paradise.

Have you ever been to a zoological garden? There are animals well fed and cared for inside the cages and we are the visitors outside those cages. When it comes to heaven or paradise, would you rather be inside that 'golden cage', well fed and looked after, or rather a visitor that enjoys all the freedom of the Universe? Heaven, hell and paradise are not the end of it, as you are inherently a God, a God that is entitled to universal freedom (and beyond) and not a wild animal that needs to be put inside a cage, even if 'golden' in nature. Why do you want to wait to learn that simple truth once behind the bars of your golden cage in the zoological garden called heaven or paradise? A God would never put itself behind bars; not even 'golden' ones.

But GREED is our inborn nature as we strive to be EVERYTHING, which is the inherent quality of a God. The mistake we make, however, is that we are looking for EVERYTHING in the wrong place. Our route isn't linear but circular. Where is EVERYTHING in a circle? It is found at a place that is called 'Infinite' in terms of distance. And where is 'Infinite' in a circle? It is right there where the circle ends. And where is the end of a circle? It is right there where it started: The backside of the point 'Zero' is 'Infinite'. So rather running 'forever' through a circle of infinite diameter, revert your footsteps and return to 'Zero' where it all started.

In NOTHING you will be EVERYTHING!

## **Divine Logic versus Human Logic**

Human logic drives one to run for 'Everything' in small accumulations of 'Something' through a circle of perhaps infinite diameter, meaning one likely will run 'forever' without ever reaching what one craves for.

Divine Logic knows that we're moving in a circle and that that, what we are craving so much for and that drives us to be greedy to the point of self-destruction, is located right where that huge circle ends; and that's exactly the place where it started: Point Zero.

Now we stop in our heels and find us somewhere on that huge circle and wonder how to get the fastest back to Point Zero to claim our divine heritage. How do we get back? That's the wisdom of the legendary Philosopher's Stone. The treasure of the Philosopher's Stone is that it shows us the quickest route back to Point Zero. It is based on Universal Science, the inherent composition of the Universe we live in. There is nothing alchemical or miraculous in that; purest and simplest form of Universal Mathematics. It stares us right into our eyes in the world we live in - and we still can't see it, as we are too busy to see it. We are so busy trying getting to 'Everything' by acquiring one 'something' after the other. We can't see that great shortcut to Zero that is staring into our eyes wherever we look in nature and universe; perhaps because we are so much afraid of 'zero' that mentally we associate with 'nothing'.

Have a closer look!

# **END OF PART I**



**SPACE FOR YOUR HANDWRITTEN NOTES TO PART I**

# **PART II**

## II.1.0 The Secret of the Legendary Philosopher's Stone

When one designs a symbol, the designer usually knows its meaning. A symbol has the advantage that it might survive for centuries while languages may change and die out. How to explain anyone in a dead language anything?

The problem of a symbol, of course, is that its actual meaning might get lost. There is a symbol of some meaning, but no one knows anymore what it is supposed to tell. One of such symbol is the legendary Philosopher's Stone.

When one looks at the Philosopher's Stone Symbol, one sees a six-pointed star within a circle. What is that supposed to mean? What the viewer sees, however, is not what its originator has drawn. The finished drawing only looks like that, but isn't meant to be that. It is for such reason that symbols are being misinterpreted.

Figure II.1 shows a typical presentation of the 6-pointed star within a circle. This is a true and correct presentation of the meaning of the legendary philosopher's stone. But when one realises its true meaning, one will find that one could illustrate such meaning in many other ways. The original author, whosoever it may have been, liked the star and circle version and so declared that to be the Philosopher's Stone. Whatever one touches with the Philosopher's Stone turns into pure Gold, it was said. Certainly true and correct for the one that understands the Philosopher's Stone and knows how to use and apply it.

Rather than explaining the meaning of the Philosopher's Stone and its practical applications at this stage, we will set out to give other illustrations of the Philosopher's Stone and ask our readers, whether comparing those illustrations they can figure out the meaning of the Philosopher's Stone themselves. It is really simple; but things are just not as one sees them. One really needs to take a few steps back and then have another look. The message is very simple and we can see it everywhere in nature. It's just that we got programmed as children to think in certain ways, largely based on culture, tradition and religion. We can't see clearly, as our minds were misprogrammed.

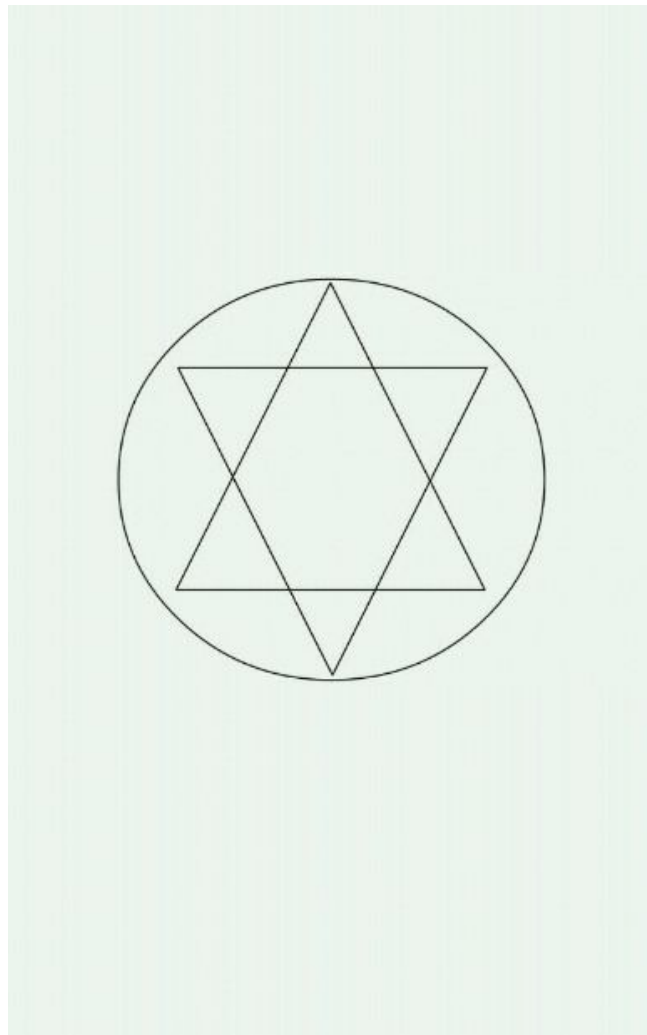

FIGURE II.1 The Symbol of the Philosopher's Stone

The illustration or symbol in Figure II.1 is the classical depiction of the Philosopher's Stone. But does it really depict a 6-pointed star within a circle? Have a closer look, or better step a bit away to have a broader view.

If your view is still not broad enough to see things a 'different way', have a look at Figure II.2 and try to put that into a context with Figure II.1.

Do things now make more sense?

What do you see in Figure II.2 which is different to Figure II.1? Isn't there are square divided into two halves which is surrounded by a circle? How could we bring, logically, these two illustrations together? How do they relate to each other?

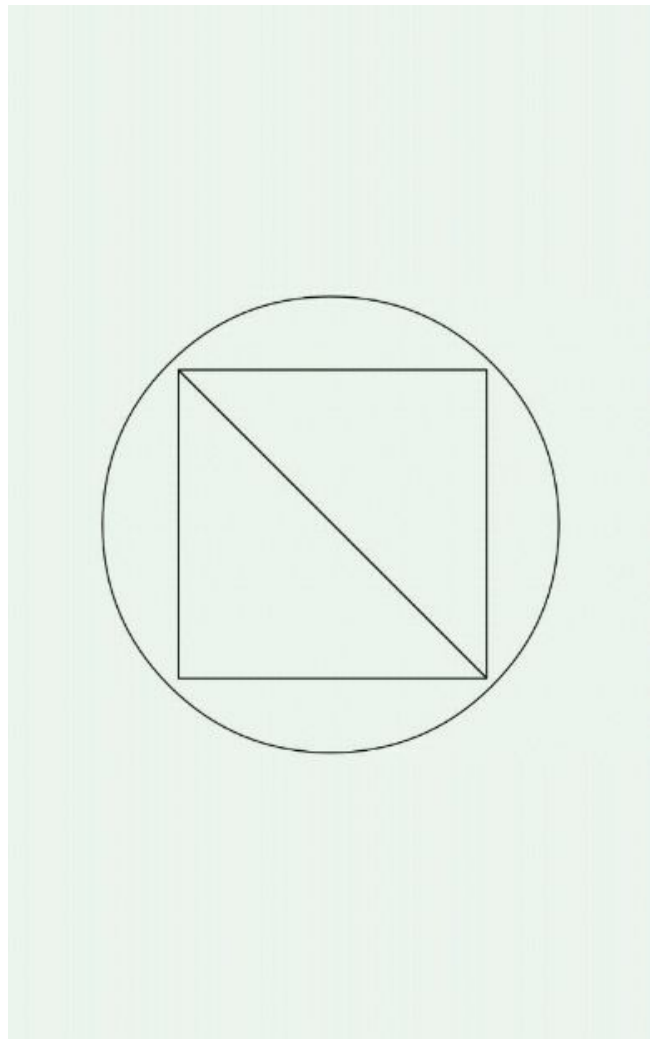

Figure II.2

An alternate illustration of the Philosopher's Stone

We will not give away the secret of the Philosopher's Stone at this moment and go rather to a scientific consideration, out of which the statement of the Philosopher's Stone will become clear. It is really all childishly simple.

The Philosopher's Stone is, as the name says, the Stone of Wisdom. It provides golden wisdom and not, as some alchemists are dreaming, physical gold. If you are really interested in golden wisdom and not just physical gold, please read on. Otherwise you may be greatly disappointed to find that physical gold can't be produced with the Philosopher's Stone, though one could become sound and well on Earth by using its message in one's financial affairs.

## II.2.0 Scientific Analysis

Now things might get a bit too scientific or mathematical for some readers, though it's just basic science and mathematics. We will talk in the following about a simple natural phenomenon that we may have seen already many times without giving it much thought: The creation of a wave in the water.

It's a bright calm sunny day and we go to the lake for a picnic. The surface of that lake is mirror flat, so calm that we could see our own reflection in it without any distortion. This is the lake without any waves on its surface.

We start our picnic and within a few moments dark clouds appear on the horizon. Bad luck, a thunderstorm is on its way. We quickly pack up and look for and find some suitable shelter. From here we are observing the events in nature as they develop. The wind has freshened up and the surface of that beautiful lake is no longer mirror flat; it has become quite ruffled with little waves. If we'd now look into that lake, we no longer could see our mirror reflection in it.

The breeze develops into a storm with thunder and lightning. The little waves from before have changed into big ones and the entire lake is in some sort of movement. We are glad that we had sought and found shelter. We observe the activity of the lake surface. However in spite of all that wind, thunder and lightning there is no rain; somehow the storm has passed us by. The wind calms down again and so do the waves on the lake's surface. After so much activity on its surface the lake appears to come to rest again. Soon after the sun comes out and within a few minutes all is peaceful and harmonious again like before the storm. We go back and continue our picnic.

A lovely story which we are going to analyse now. There are three situations that we are going to look upon: (1) The lake before the storm, (2) The lake during the storm, and (3) The lake after the storm.

Before the storm the lake was calm and peaceful, then the surface of the lake was in uproar with big waves due to the strong wind, and finally the lake was calm and peaceful again. Having seen so much activity on the surface of the lake, though there was no rain, what has changed? One could logically conclude that there must have been some change. What is the difference of the lake after the storm compared to before the storm?

As there was no rain during that storm, the water quantity inside that lake is the same, except

perhaps for a small portion of water that might have evaporated. But was that evaporation worth so much activity of the big waves on the surface of the water? Certainly not!

Giving things due thought we will find that there was no real change though there had been so much activity on the lake's surface. What happened here?

Effectively, water was just moved to and fro and not 'changed' essentially. The phenomenon of a wave is that it is self-compensating. Thus, no matter how many waves we've seen, all those waves self-compensated so that there was no change in the end.

We will have in the following a closer look at the wave itself and analyse what it is that self-compensates a wave. We declare empirically that the calm surface of the lake without any wave is our starting and end point. We simply call it 'Zero'.

The upcoming wind presses on the surface of the water and as the water yields it creates a dent in the surface of the water. We call that dent empirically 'Wave Valley'.

The water pushed away in the formation of the dent on the surface of the water creates a small water hill in some distance. We call that water hill empirically 'Wave Mountain'.

In our consideration of the wave we will look at three components: The wave mountain, the wave valley and the starting and end point called zero. How do they relate to each other?

When the water is pushed away by the wind to form the wave valley, such water moves immediately to form the wave mountain; it's not stored somewhere interim. This means that wave valley and wave mountain form simultaneously and not consecutively.

The amount of water within the wave mountain as such is of exactly the same amount as the amount of water that is missing in the wave valley.

The water surface of the lake has moved upwards in the wave mountain and downwards in the wave valley, starting from the common level we defined as Zero. As such, there is 'direction' involved. As we defined the level of the lake without waves as zero and the water level moved down in the wave valley, we could call the water level of the bottom part of the valley 'minus' compared to the water level at the top of the mountain that we call 'plus'. If we say the water valley bottom level is minus (-)1, then the top level of the wave mountain is (+)1. The water in the wave mountain equals the water missing in the wave valley.

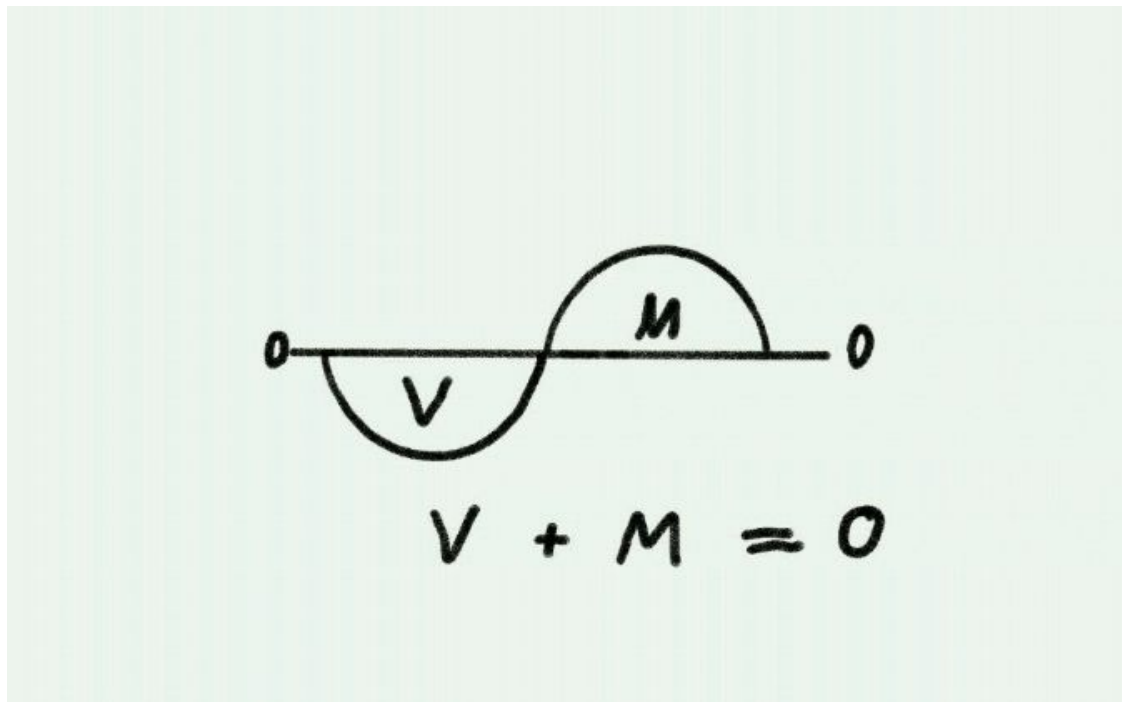

Figure II.3 Wave Analysis

We see a rough drawing of the depicted situation in Figure II.3 and the relationship is shown mathematically. Why is that so? It is because 'water missing' is negative in relation to 'water surplus'. Or if we define it in the reverse, water surplus is negative in relation to water missing. We can approach the subject either way; the fact remains that one is opposite to the other in display or direction.

If we put the water that is in excess in the wave mountain back into the wave valley, it fills the valley up neatly and we arrive again at the level zero from where we originally started out.

We could thus conclude that  $M = V$  by volume, but one being directed 'up' and one 'down' the direction is opposite, in which case one is rated by a plus and the other by a minus. Thus we get mathematically  $V + M = 0$ . Why? Because one of the two  $V$  or  $M$  is negative, whereas both are equal in value. Adding two equal values up, of which one is positive and one is negative, the result is Zero.

Let's try to put our finding from above into a symbol. We have two wave halves, one up and one down, that are divided by 'line zero'. Combining both in an addition we get Zero. What would our symbol look like?



We likely will arrive at something like shown in Figure II.4. We, the creators of that symbol, will clearly understand, what that symbol is telling us. But showing that symbol to someone who is not acquainted with the foregoing dissertation, that someone won't have a clue of what that symbol is trying to tell.

Can you put the symbol as shown in Figure II.4 into any context with the Figures II.1 and II.2 in the previous chapter? If you can, you might have solved the riddle.

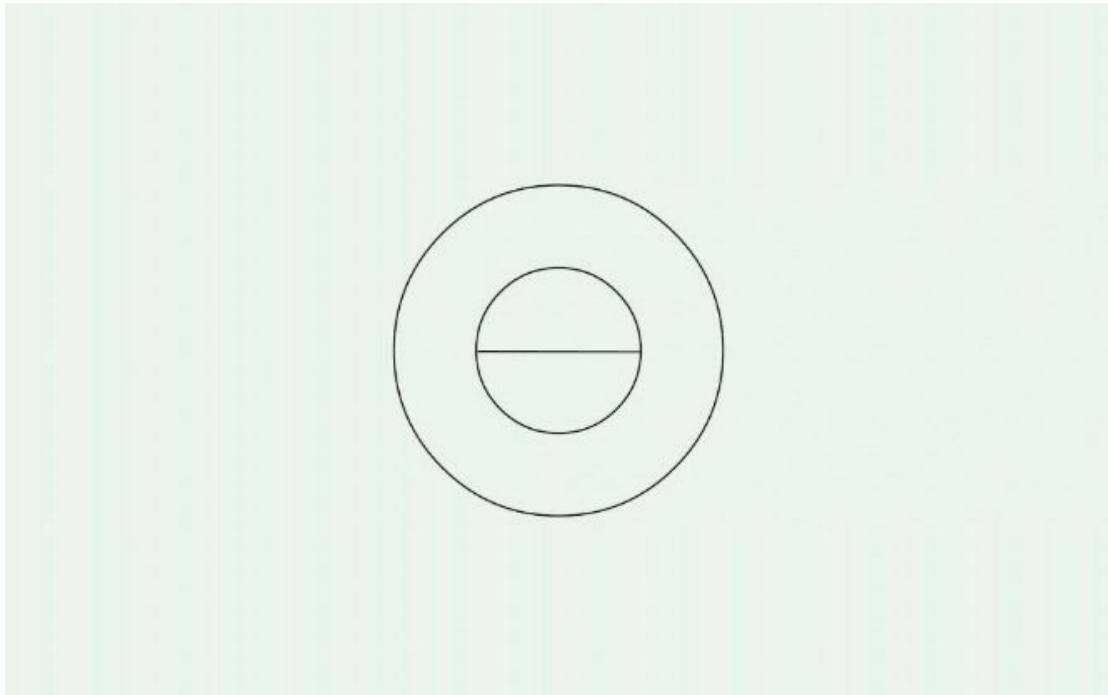

Figure II.4 Symbol of the Wave Formula  $V+M=0$

Why have we moved both wave halves into one to form a circle? Simply because we somehow must convey the message that both 'V' and 'M' are to be added up! Does that ring a bell considering our earlier symbols in the previous chapter?

## II.3.0 Further Scientific Considerations

We may have all played, at some time of our life, in a sandbox building castles. Let's go ahead and build a sand castle right now.

How do we go about building a sand castle? We'd take a shovel and fill a small bucket with sand. As we dig we create a hole in the sand box from the sand removed with our shovel. Once our bucket is filled with sand to capacity, we press the sand on the top of the bucket level and turn our bucket upside down to create the first tower of our lovely sand castle by removing the bucket carefully.

Let's step back for a moment and marvel the creation of the first tower of our sand castle.

We would certainly agree that the sand removed, if we didn't create wastage, would equal the sand contained in our created sand tower. We dug a hole and created an elevated cylinder in a similar fashion as the water in chapter 2 divided to create a water valley and a water mountain. The medium is different, but the principle is the same. The trigger is different, but the effect is relatively the same; relatively, because in one case was water and in the other sand as the medium involved. The trigger in one case was the wind and in the other our own intention to be the creators of a sand castle. What we have done here is shown in Figure II.5 below. It looks different from the sketch in Figure II.3 in the previous chapter, but the principle and the equation are the same: Sand Missing in the hole equals the Amount of Sand in our tower. Again direction is involved in that the level of sand at the start of our action went down when creating the hole and went up when creating the tower. Unlike the water levels, however, the creation of hole and tower did not happen simultaneously as in the wave, but subsequently as we stored the sand, interim, in our bucket before we created the tower. We see on this example, clearly, that nature creates simultaneous while we create in stages. It may be this pattern of human creation that we have come to the conclusion that the biblical Adam and Eve were created 'in stages' one after the other and not simultaneously as a pair of mirror like opposites. We open this subject to discussion...

Whether Adam and Eve were created one after the other like we did things in creating our sand castle or were created simultaneously like the wave out of the previously mirror flat surface of the lake, in both cases the Equation would be the same:

$$\text{Male} + \text{Female} = 0$$

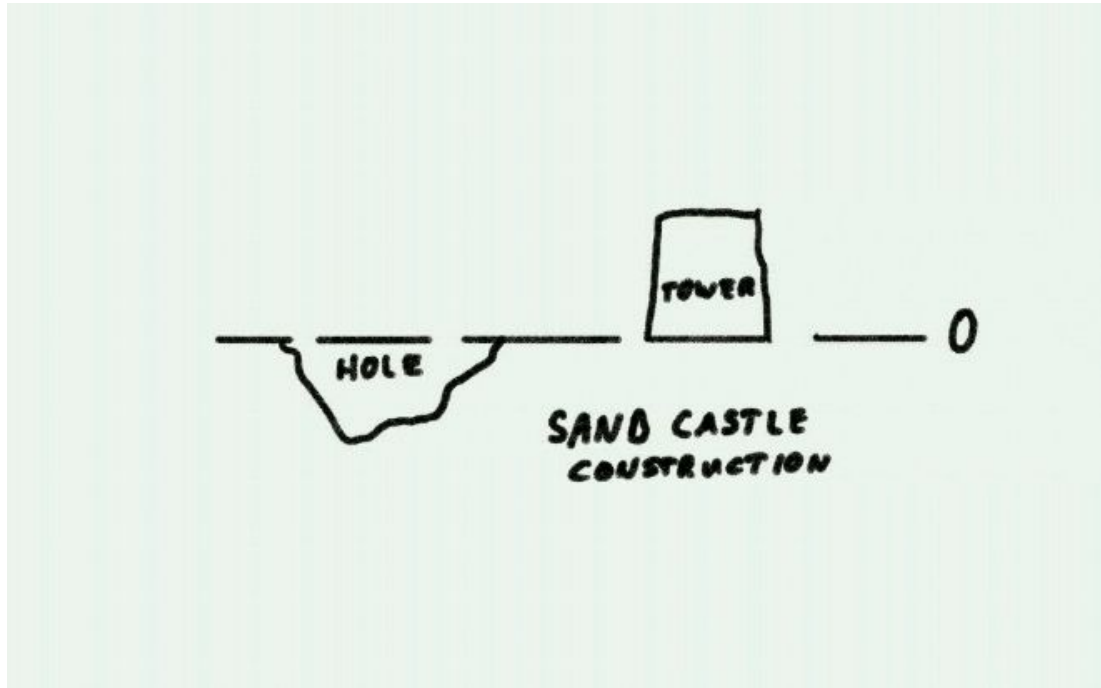

Figure II.5 Sand Castle Construction

If we were the God of the Macro Cosmos and had to create an entire Universe, would we need a 'bucket' to store one expression of a dual set till we had decided what to practically do with it? Yes, perhaps Eve was temporarily 'stored' in the 'rib' of Adam, as the biblical story tells. Or that story is more of a poetic nature. What do you think about that story in the context of the just learnt?

If we depict Adam as a triangle pointing upwards and Eve as a triangle pointing downwards, our equation will look like depicted in Figure II.6 below.

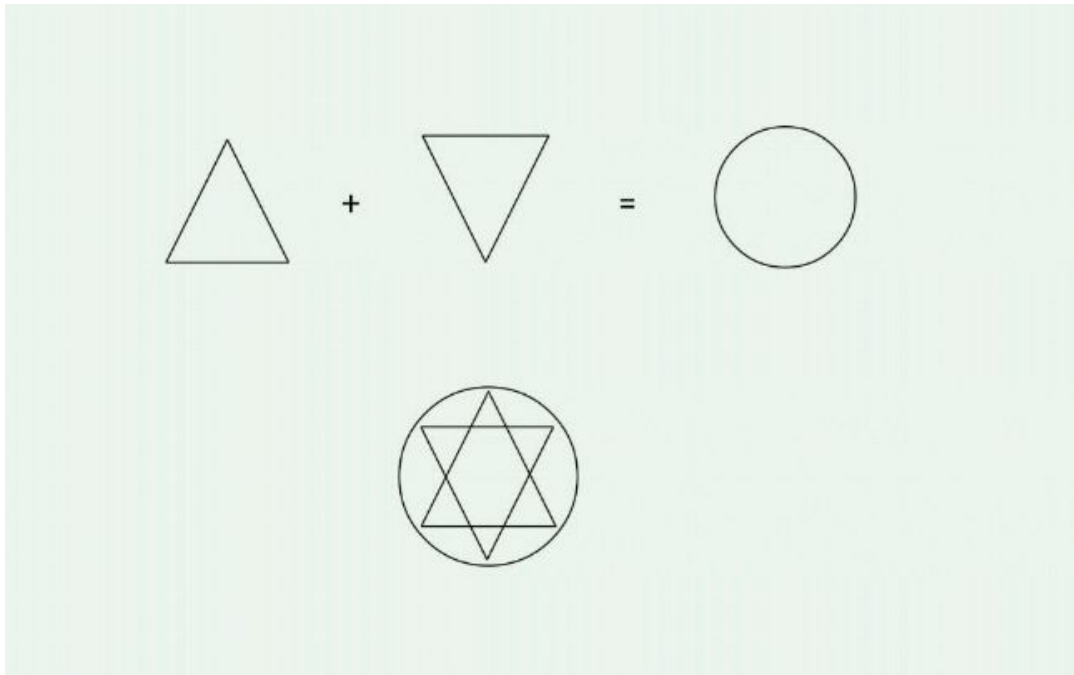

Figure II.6 Triangle Equation and Combination

If we move the three components of the equation into one symbol, we find the same illustration as shown on the bottom of Figure II.6 above. Please compare that combination with the one shown in the earlier Figure II.1 and you have solved the riddle, if you have not yet solved it earlier on your own.

## II.4 Advanced Scientific Considerations

Talking about the relationship of Adam (male) and Eve (female) in an equation we have used symbolic expressions. It was our own choice and definition to do so. Of course, if we use symbolic expressions different from the upwards pointed triangle for Adam and the downwards pointed triangle for Eve, we arrive at different symbols and illustrations. The choice rests with the author. What counts is the overall meaning of the expression. If the meaning stays the same, many other illustrations can be used in describing the same thing.

Figure II.7 shows an optional alternative to expressing the same thing in a symbolic way.

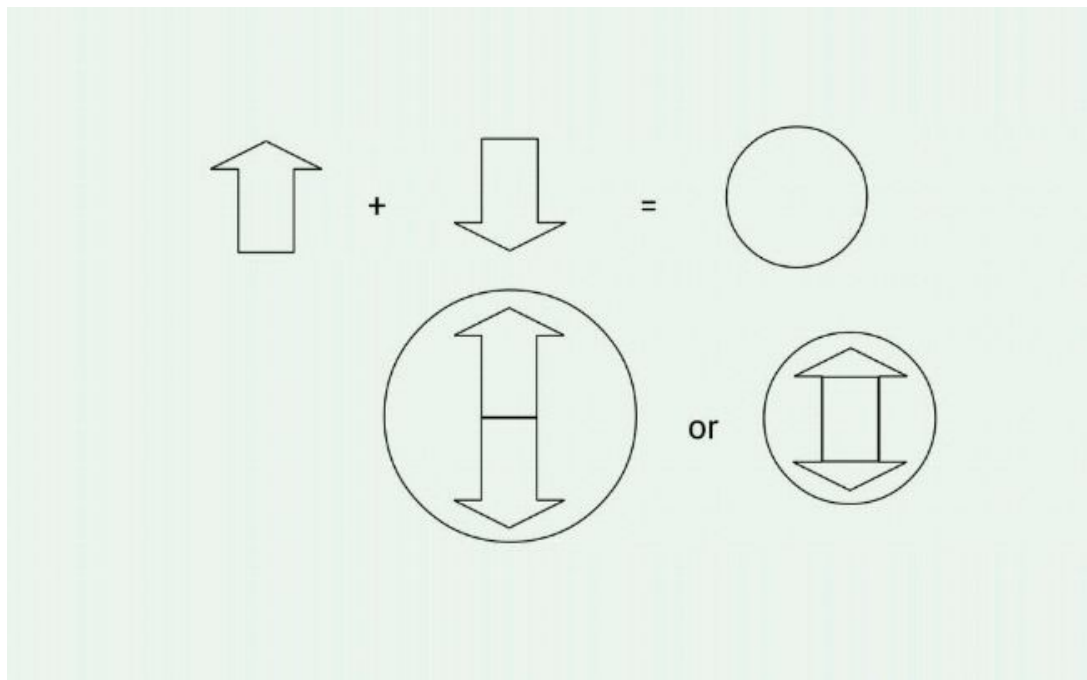

Figure II.7 An alternative symbolic presentation of the Philosopher's Stone

We see on this and earlier examples that there are different ways to express the same thing symbolically. However, starting with a symbol, without a detailed explanation from the author about definition and meaning of the symbols chosen, we won't understand what they mean and how they were composed.

We hope that we have filled here the gap of understanding the legendary Philosopher's Stone, its meaning and how it has been composed. You are free to compose any other symbolic expression of the Philosopher's Stone on your own, making it easier or more difficult to

understand. One could even express things as shown in figure II.8 below; but can you still figure out what its author is trying to say?

A square is created by combining two opposite pointing rectangular triangles. As such the square symbolises the addition of two opposite pointed triangles. The first clue is the triangle, the second clue is the square telling to add two opposite pointed triangles up and the third clue is the circle saying the sum results in zero.

How difficult can one make a symbol to be understood by the non-initiated outsider? Keep it simple, please!

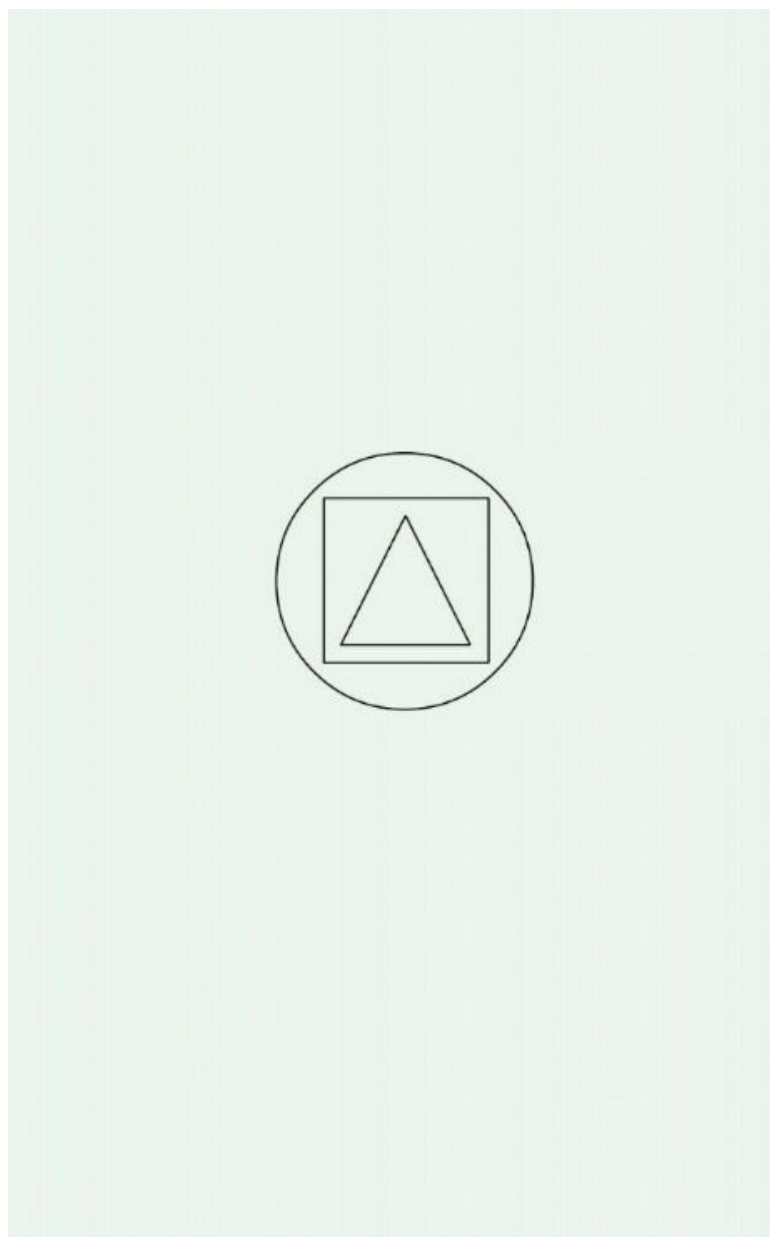

Figure II.8 A symbolic expression that rather confuses than helps

Now we have a symbol that tells us something, but we still don't understand what is it good for. How does the Philosopher's Stone produce 'gold' for us?

The 'gold' of the Philosopher's Stone is 'golden wisdom' and not physical gold. Apologies to all that were hoping to become immensely rich by discovering the Philosopher's Stone. But one could become extremely wise by using the Philosopher's Stone, indeed.

There is a second clue that underlines the meaning of the Philosopher's Stone that we will talk about in the next chapter. Without that clue the message of the Philosopher's Stone is fairly meaningless. What does it mean that Male and Female added up will result in Zero? Are we engaging now in a practice that makes things 'miraculously' disappear?

## II.5.0 Universal Aspects

We live in a Universe where everything is circular, in one way or another. We may not be aware of that fact as these 'circles' could be gigantic in comparison with our common human outlook. We could thus mistake universal processes as linear ones, having a start and an end. As a fact, in a circular movement, there is repetition, over and over again. When did it start and when will it stop? No one is able to tell.

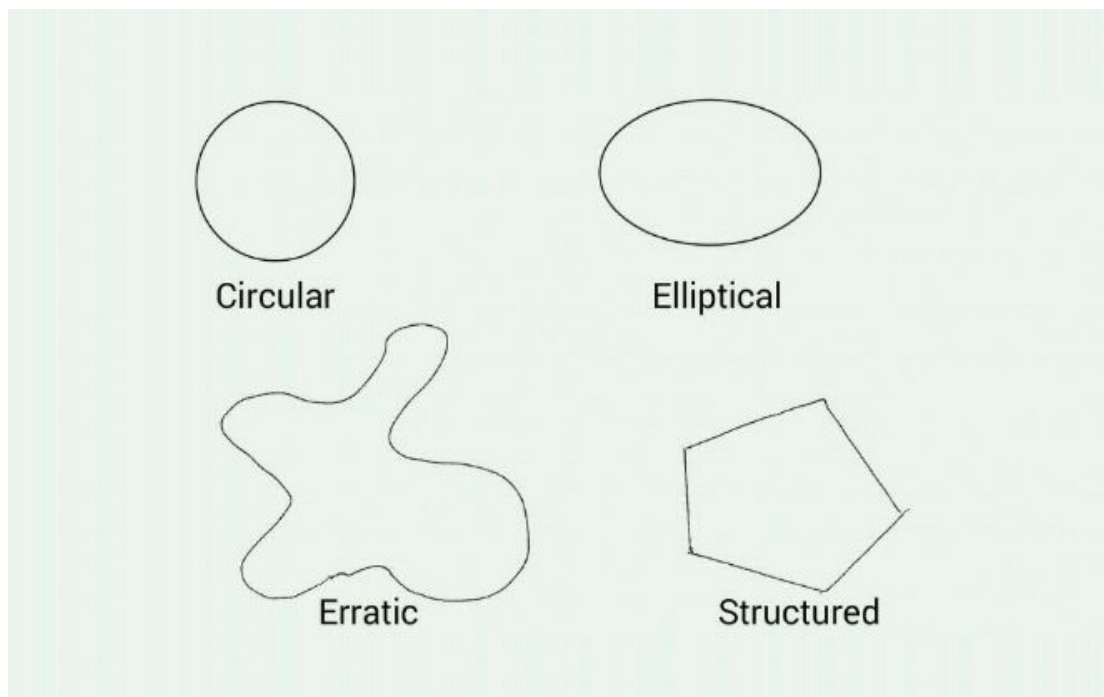

Figure II.9 Illustrations of Circular Movement

Figure II.9 shows a number of illustrations of different circular movement. In all cases, when drawn with a pen, we start our drawing 'somewhere' and end our drawing where we have started it; that's the definition of 'circular'.

What we are particularly interested in is to understand the nature of the starting and end point of a circle. In their inherent nature all these illustrations are limitless without a start and an end. But in their CREATION we started somewhere, and that point, incidentally, is also the end point. So what we are now exploring is CREATION; how did it all start?

Zero is the point where we put our pen onto the paper and the furthest point from the starting point is Infinite. That's, incidentally, the same point from where we started our drawing from. Why? It's because in a circle the furthest point from the starting point is the point where the



circle closes.

Our Universe is structured circular; that's circle, elliptical, erratic or structured in nature. But in all these cases the starting point Zero is the same as the end point Infinite. What does make it Infinite? The diameter or inner space within the boundaries of the circle is undefined.

## II.5.1 The Area or Region around Start and End - An Analysis -

We are going now to analyse the area or region around the starting and end point, as they are the minimum and maximum, combined in zero and infinite in one location.

We will do that exponentially in looking at the area or region that describes mathematically as

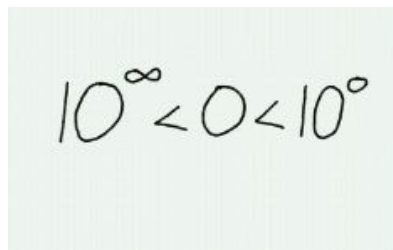
$$10^{\infty} < 0 < 10^0$$

which is the area between  $-1 < 0 < +1$

This is the area or region in which started and in which ends our circle. That's the way we have drawn it. But how could we put opposite ends like Zero and Infinite into one consideration? Simple, we have a closer look at a common coin. Have you got a currency coin in your pocket that you could pull out now to have a closer look?

Our coin has two sides, which correspond to Infinite and Zero, but there is a third side of the coin. Can you see it? Yes, it is the circular rim of the coin. It's not a side, you say? Think again? A cube has six sides as we know, one on the left and one on the right side and four on the circumference of the cube. If we smoothen the four sides on the circumference of the cube down, they will merge into one circumferential side. That's the third side of our coin.

With Infinite being the left side of our coin and Zero the right side of our coin, then what corresponds to the circumferential side of our coin? Is there something in between that's the common denominator of Zero and Infinite? There sure is!

Our coin has three sides and without the circumferential side of the coin the coin would simply not exist. That means that the circumferential side is an expression of the existence of the coin, which makes the other two sides feasible in the first place. Without a coin we can't speak of the two sides of the coin, can we?

Let's sit back for a moment and consider WHAT we have discovered here.

## II.5.2 The Third Side

We have so far understood that in a dual field consideration there are two sides. Now we discover, to our great surprise, that the two sides are 'resting' on the base of a common denominator that facilitates the two sides in the first place. Similar as in 'non-existence' of the coin its two sides can't exist either, so Zero and Infinite can't exist without the base of their common denominator. Then what is that common denominator?

Okay, Zero and Infinite are opposite ends, which in a circle, incidentally, are the same point. Is there something within the base of that point that forms the foundation of both Zero and Infinite? What could be more than Infinite and less than Zero? Valid questions, indeed.

The clue here is that Zero and Infinite are opposite ends. The common denominator could be described as a mirror surface that projects one side to the outside of the mirror and one side to the inside of the mirror. Both the inside and outside projection are standing opposite, speak 180° reversed, to each other. That's the nature of our Universe; things are not only circular, but also mirror-style dual projections. The projector in this case is the mirror pane.

So, we would be very wise now to start with the mirror pane that projects a dual world that is, effectively, two opposite sides like in a mirror. Then what is that what we know as Zero? We always thought that Zero is absolute Nothing and Infinite is absolute Everything.

Nothing and Everything, just like Zero and Infinite, are RELATIVE to each other and not absolute. There is a third, a common denominator, in the picture, but what we call that common denominator? The common denominator is neither Zero nor Infinite, but is the base and origin of both, like the two sides of the coin owe their very existence of the coin to the coin in between.

We are bound to create a new word to explain that common denominator. In chapter 1 of Part I of this Book of Ultimate Wisdom we were already forced to create a new word, because we realised that VOID is relative and not absolute. We switched vowels to arrive at the new word VIOD. We could use the same strategy now here in that we switch the vowels in the word ZERO to read ZORE. The third side to Zero and Infinite we would thus simply call Zore to give it a distinguishing name. A base that is called Zore is thinly coated with two sides, of which one is Zero and the other Infinite, similarly like the coin is 'coated' with a left side and a right side. There are 'three partners' in the play and not just two.

### **II.5.3 Our Universe Unveiled**

Our Universe, as we have so far explored it, is dual and circular in Nature, but effectively projected out of a THIRD which thus makes our Universe not only a DUAL, but effectively a TRIUNE WORLD.

We will need perhaps a few moments of contemplation to come to terms with that. What are the consequences to that? Start and End Point, Zero and Infinite, are the same point, and they, like any other dual expression, are resting on a THIRD that is their common denominator.

In order to see things in more clarity, we have to start our considerations with that common denominator and not with the dual projections that have come out of it. Now we may be in the dilemma of having to create a lot of new words to describe the various common denominators to all dual expressions in our language. Certainly, a big task ahead.

Out of a common denominator not only dual expressions have been projected, but also multi ones. We could describe such 'multi-ones' as structured circles like the one shown in Figure II.9 above on the bottom right side. What would be the common denominators to terms like Nationality, Culture, Class/Caste/Race and Religion. They all are projections only out of a common base and denominator, and also so male and female. What is the common denominator to male and female, and perhaps human and divine? Things are all circular in our Universe and based on a common denominator which originally 'projected' them. In order to understand the Nature of the Universe we live in, we have to discover and explore, starting from that common denominator and not, as so far, starting with the projections.

It is advisable at this point of time to define a new symbol for that denominator that is the common base or projection point for both Zero and Infinite. So let's design a symbol that

reflects both Zero and Infinite in one.

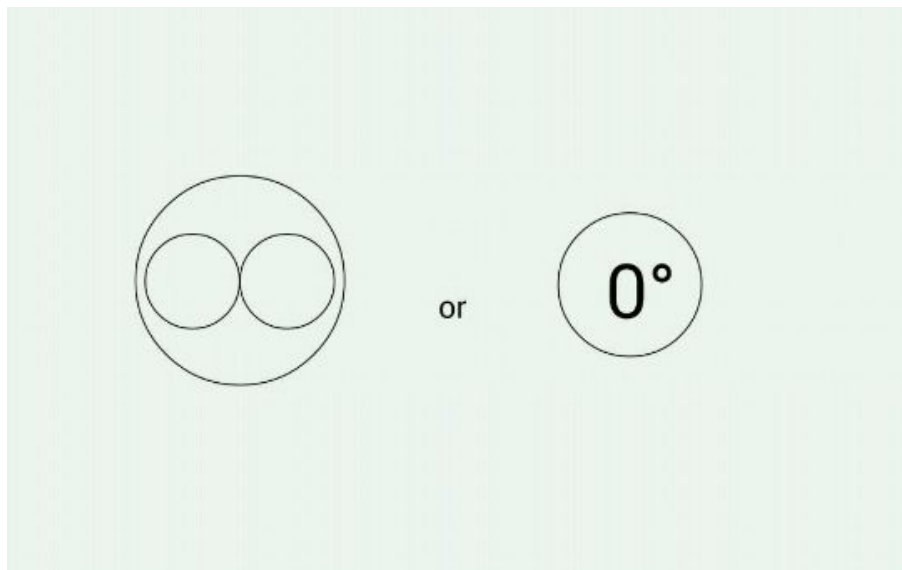
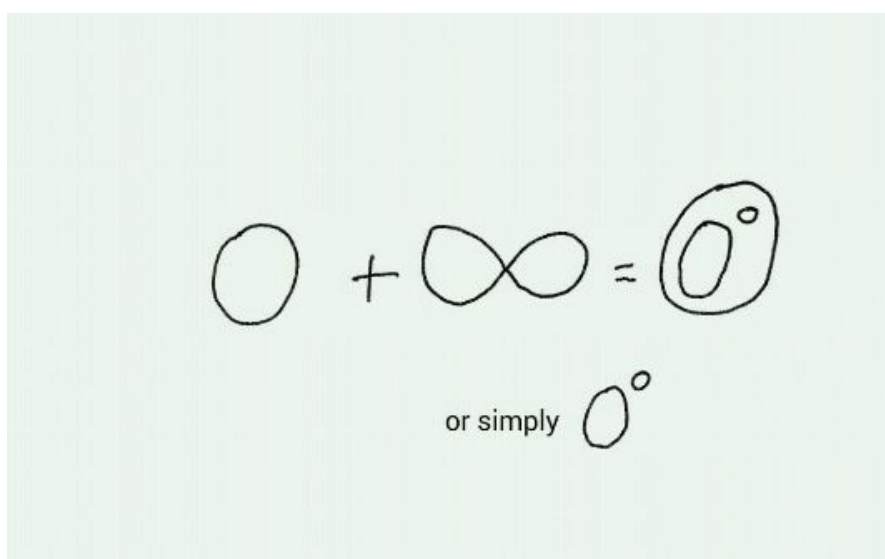

Figure II.10 The Zore Symbol

### II.5.4 The Third Angle called Zore

We have now defined something new that could be called  $0^\circ$ , meaning Zero by degree or relativity, as we also could call the opposite, Infinite by degree. We understand now perhaps that in our Universe both Zero and Infinite are relative and not absolute. They both are dual projections out of a Third that we simply called Zore. The relationship of these three 'angles of perception', as we appropriately would call them, is as shown in figure II.11 below.



## Figure II.11 The Relationship of the Three Angles of Perception

This is, once again, our simple equation, which we know already from our earlier Philosopher's Stone. That wisdom, indeed, takes us beyond our world and helps us to understand our entire Universe. It is for that reason that the ancients treasured the Philosopher's Stone so much.

Then, what is Zero in absolute terms and what is Infinite in absolute terms, we might want to ask here? There is only one simple answer to that valid question. There is no absolute. All is relative, and so is our existence here on Earth. A God can only be a God RELATIVE TO something that is not God and a King can only be a King RELATIVE TO something that is not King. Our entire Universe is structured like that. It is our own human perception and yearning for something constant and permanent that we are clinging to the idea of something that is absolute. We ourselves are only RELATIVE PROJECTIONS out of something that is RELATIVE TO US.

Then perhaps our newly defined Third called Zore ( $0^\circ$ ) is absolute? No, it is not either. Even Zore is relative. It is relative to the other two viewing angles Zero and Infinite.

Why do we talk about viewing angles? We call these three 'viewing angles', as we must shift our view to see things from their sides and not just out of our own human perspective. The confusion that persails human beings from time to time is caused by us wanting to understand our Universe out of our viewing angle. That leads to misconclusions, as we are the product and not the creator. We are the end of the line and not the starting of the line, so to speak. In order to understand our Universe and our existence therein we must shift our viewing angle away from ourselves and take the position of viewing the entire settings from the Origins, called Zore in our case.

We know that the tree has a part above ground and a part below ground, but to really understand the tree in its inherent nature we must start our investigation from the SEED, out of which the tree has grown, and not just from the fruit on its branches, which is the product.

The part above ground of the tree relates to the part below ground, and vice versa, and both relate to the seed that has 'projected' them. Zore in our case is the SEED and we would do well to shift our attention to understand Zore and use it as our viewing angle to understand our world and universe and our existence therein.

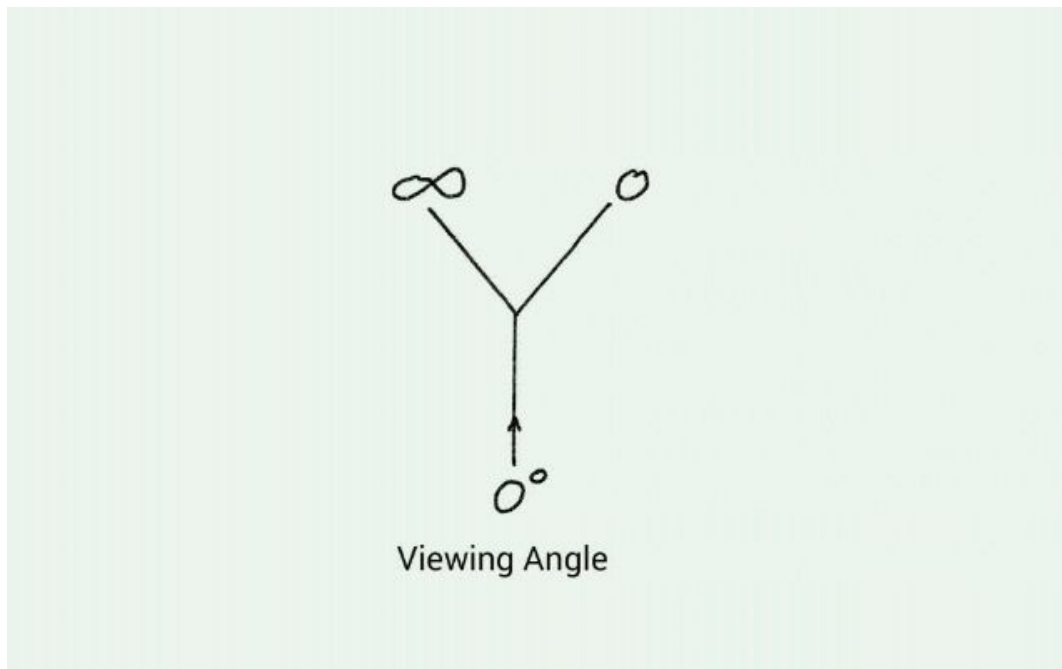

Figure II.12 Zore  $0^\circ$  as the viewing angle

Well, we know now that our world is a dual projection, mirror like, out of a Third that we called Zore and we also know now that things are circular in our Universe. If Zore is the INLET, then our Universe could be compared with a huge bubble or balloon filled with 'air' and Zore is the 'inlet valve' where the 'air' comes in to 'inflate' that balloon. Then what would our graphic in Figure II.12 look like, if we consider circularity.

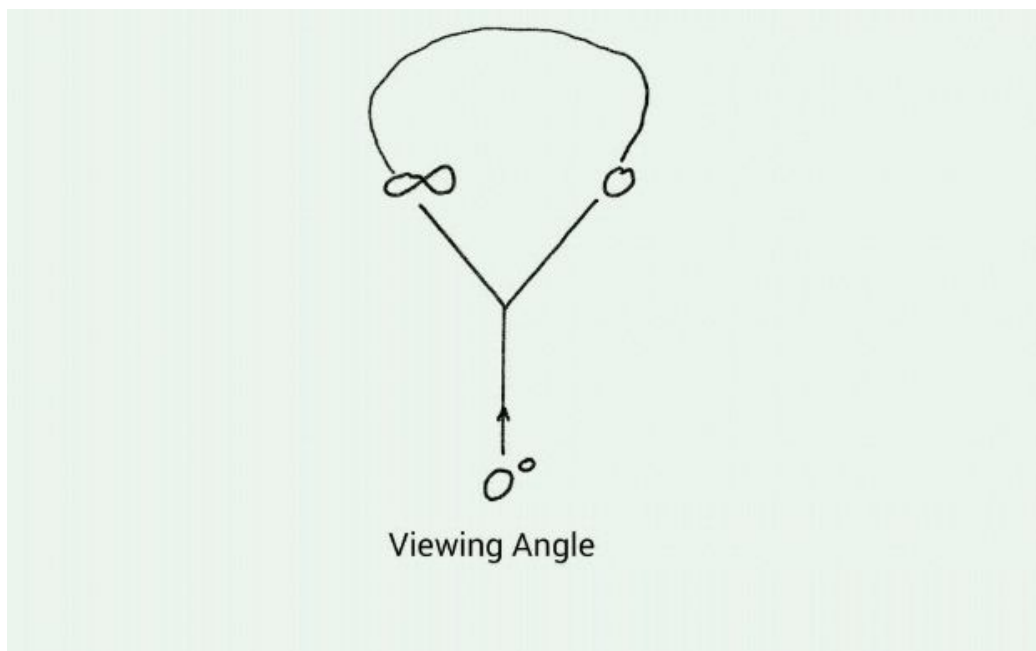

Figure II.13 Our Universe looking like a Balloon

## II.6.1 A small Analysis of our Universe

We have found, by investigation, that our Universe is circular in nature, dual projected out of a Third, which we simply called Zore ( $0^\circ$ ), and could be depicted like a balloon floating in an even larger 'something'.

There are many dual configurations in our Universe and languages. We will have a closer look at the phenomenon of mass and energy using our knowledge acquired so far.

In line with Figure II.13 in Chapter II.5.4 we have redrawn things for Mass and Energy in Figure II.14 below.

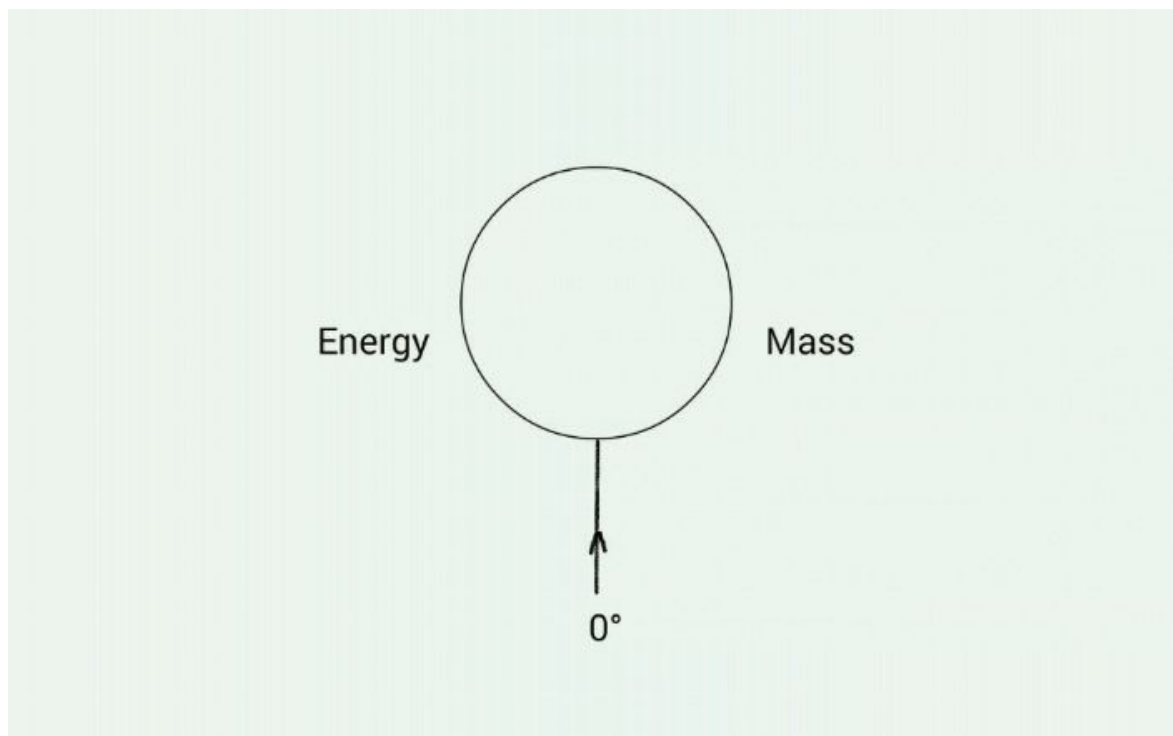

Figure II.14 Mass and Energy in relation to Zore  $0^\circ$

In absence of us knowing the actual THIRD to Mass and Energy we have redrawn things using the same general term Zore  $0^\circ$  that we already used when studying Zero and Infinite in that context.

We see in Figure II.14 that due to the circular nature of our Universe both Mass and Energy have two connection points in our circle. One such connection point is where there is the common base or denominator  $0^\circ$  that projects dual into mass and energy and the other connection point is somewhere on the circle itself.

What will happen on that unknown point on the circle, where mass meets energy and energy meets mass. There will be a conversion of one into the other or vice versa, won't there?

Mass is non else than condensed energy and energy is non else than uncondensed mass. What could be the criteria for such conversion?

Light is energetic in nature and travels at light speed. If we reduce such speed of light below its nominal value we would create mass, in all likelihood, and if we increase the speed of mass to close or beyond the speed of light, mass would become light or energy. So there is a way to move mass at and perhaps beyond the speed of light by us knowing now the relationship between mass and energy and that mass could convert into light energy at the speed of light.

What would it mean, if we travel at the speed of light through space? What will happen to our human bodies then?

Our human bodies have mass, which is none else than condensed energy. If we'd move our human bodies at the speed of light, our bodies would convert into light energy that can be transported at very high speed and converted back into body mass, once we slow down.

## **II.6.2 We got into the Circle; how to escape it again?**

We see in Figure II.14 above that there has been an inlet or projector that started and likely sustains the circle. We have come into this world through some 'gate' or 'inlet valve' and now are literally running in circles trying to find the 'exit' again. How will we get out again?

Zore 0° was the 'gate' through which we came in and is also the 'exit' through which we get out. Whatever considerations we have in our dual structured world, we need to find the common denominator of each and every concept or consideration, as that was the 'inlet' and consequently is also the 'outlet'. Ultimately, we are living in a world of concepts that we have made our own in absolute terms, when they are really only of relative nature. So, first we have to let go of our cherished absolute perceptions and accept that things are relative. There is no absolutely right way of life, no absolutely right religion, no ideal nationality or culture; all is relative to each other and finally to the common projection point we called Zore 0°.



If we want to solve the riddle of our own human existence, we better start thinking and understanding in relative ways, instead of absolute ones, and be on the look out for the common denominators, where the circle closes. That point, where the circle closes, is also the point where the circle we are running in started and that's where the entry and exit gate are.

We may now perhaps understand one of the key messages of the Philosopher's Stone, which points out to us the fastest way to get 'out of the vicious circle' we have made our home.

The entry point is both Zero and Infinite and so is the exit point. We can strive to make it all around that circle to the side which is called Infinite, due to a non-defined circle diameter, or courageously head back to the point called Zero, which is likely the shorter route.

Consult the Philosopher's Stone in all your considerations, please, to quickly find your way back to the inlet point  $0^\circ$ , which is also the exit point.

Afraid to head back to Zero or Nothing, when each human being strives, so desperately, to at least be 'something', the more the better? Think again! That point that shows itself to you so nastily as 'Nothing' is, incidentally, also the point where you'll be 'Everything' without having to take the very long route through an entire circle. The ones that strive to be 'Everything' best revert their footsteps and strive to be 'Nothing'; especially with us knowing now that that 'Nothing' is of a relative nature and not of an absolute one. In 'Nothing' we will also be 'Everything' and in being both, relative Zero and relative Infinite at the same time, the entry/exit gate  $0^\circ$  opens and we can slip out into the much better world, beyond that vicious circle' in which we are stuck now.

That is the inherent message of the Philosopher's Stone; it shows us how to get out of our self inflicted madness after entering that vicious circle of human existence, life and death, in the first place.

The Gods must be crazy; it's time that the Gods come back to senses. Claim your inherent divinity and be yourself: A God and not a human being!

Isn't being a FREE GOD a better choice and option than being a human being incarcerated, perhaps etemally, in a golden cage that is called heaven or paradise?

### **II.6.3 Introduction to Part III of this Book of Ultimate Wisdom**

We are moving now on to Part III of this Book of Ultimate Wisdom. We are Gods and not human beings inherently. So it is our birthright to live and act like Gods and to be able to do so we must first be able to think and understand like Gods. No matter what the state of our own self-created madness of perceiving ourselves as human beings, there is a way out of the dilemma. That way out is discovering the nature and structure of our world, triune and not just dual in nature. We are living in a world of self-created concepts, concepts that have utterly confused our minds. We no longer know what we are and what we are doing. It is by uncreating these self-created concepts that we are finding the way back to ourselves.

Just thinking and talking about it, perhaps for fashion's sake and popularity, will not do. Whichever concepts we are living now, we must replace them with new concepts on a 'higher scale'. Realising such concepts is important. The English word 'to realise' has two meanings in such context and both are applicable. First we must realise the facts that are applicable and separate then myths from the facts. Having understood, we must proceed then to apply, to realise what we have understood. We have to live those facts and not just talk about them. Living those facts new understanding will come and new ways of application of such understanding will be discovered. This way it will go on and on and we will arrive at ever new heights of ultimate understanding. This Book of Ultimate Wisdom is just an Introduction to that. Divine Knowledge and Wisdom can't be spoon-fed to human beings; it needs to be self-realised. There is much, much more behind and beyond what has been given and presented to you in this Book of Ultimate Wisdom. It is up to you now to explore and apply.

It is your Divine Birthright to know, as you are a God in your inherent nature and not a human being. But, nevertheless, irrespective of Birthrights, your own effort is required to get yourself out of your current human perceptions. You, as a God, created the erroneous perception of you being a human being and only you can remember again that you are a God. As long as you are living and practising human values and ways you'll remain a human being; it's by living and practising divine values that your memory will wake up and you'll remember again.

In Part III of this Book of Ultimate Wisdom we'll be giving to you some insights out of a Divine Perspective; more for orientation than understanding. As you are moving along the road of self-rediscovery, to your own inherent Godhead, you'll be making surprising discoveries, unbelievable in ways and nature. Having some milestones on your journey, just for orientation's sake, will help you to find your way. Thus is the purpose of Part III of this

Book of Ultimate Wisdom; to convey 'milestones for orientation' and not to provide knowledge and understanding to human beings. Divine knowledge and wisdom can only be understood and appreciated by the one that has reached, has established itself in its inherent Godhead. Trying to understand by human interpretation is futile; it only creates misunderstanding and confusion. The human being thinks and feels different from a God; how then a human being can understand the nature and wisdom of a God. An animal is unlikely to understand the world of the humans; similarly it would be impossible for a human to understand the world of the Gods. But the human has the inherent capability to grow into Godhead and out of Godhead nature such ex-human being then finally will understand.

**END OF PART II**

**SPACE FOR YOUR HANDWRITTEN NOTES TO PART II**

# **PART III**

## **PART III - DIVINE AND SUPRA DIVINE INSIGHTS**

This Book of Ultimate Wisdom would be incomplete, if we were to finish with just human and scientific insights as shown in Part 1 and Part 2. Divine Insights are 'foreign' to human nature and thinking, as 'the Gods' have a different logic and look at things differently. The supra-divine sphere of thinking and feeling is even more 'foreign' and many human beings of this so-called modern society of the 21st century of the Christian calendar don't even know yet that there is a supra divine sphere beyond the human and divine fields.

We'd like to therefore suggest to 'take' the divine and supra divine aspects 'as is' and not try to understand by ways of interpretation. In order to understand and assimilate divine insights one would have to be a God oneself; able to think, feel and understand divine. Same goes for the supra divine field.

Then why go there at all, when incomprehensible to human beings?

As we practice we grow and may become Gods eventually and then will be able to grasp and understand divine wisdom. This Book of Ultimate Wisdom is, in such context, not only written for human beings and human scientists, but also for divine beings and supra divine beings. The discussed subjects are not meant to be all comprehensive, but more informative for orientation. There is much more to things than we could compress into a few pages of a book of any kind and format. Those that have 'reached' will easily understand; those that have not yet reached may speculate, wonder and marvel.

Let's now hop into the field of divine insight and divine science to be followed, later, by supra divine perspectives.

### **III.1.0 The Relative Nothing and the Relative Everything**

We have discussed in earlier chapters the basic nature of our Universe resembling an inflated ballon with an air inlet at the bottom. We go back to that illustration and further develop from there. Please refer to Figure II.14 of Chapter 6 in Part II, which we have drawn up, once more, for convenience below.

What is interesting for us is to understand the transition areas where energy and mass are meeting. We can see that there are two such meeting points, one at Zero and one somewhere

on the circle. What is happening there and how are mass and energy interrelated?

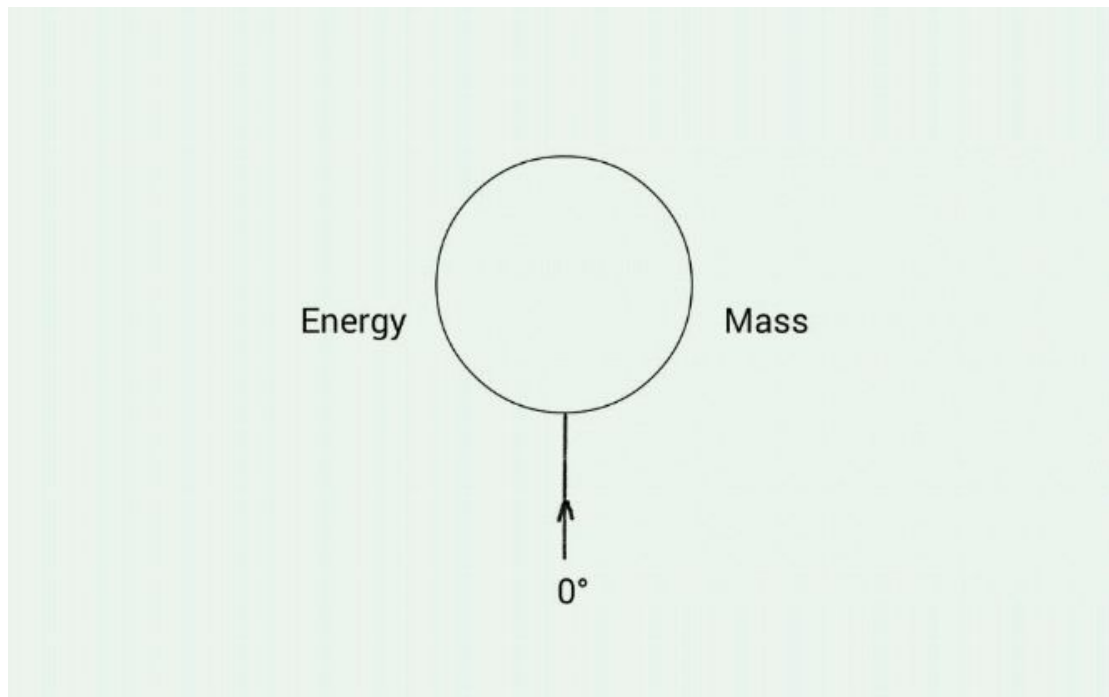

Figure III.1 (same as Figure II.14)

We have earlier discovered that due to circular nature the definitions of Zero and Infinite, of Nothing and Everything, are essentially the same: Where it starts there it ends.

But now that we see that a THIRD has come into the picture that essentially is the foundation, if not originator and projector, of the dual pair, we need to expand our mental horizon. We will have a closer look at the area close to Zero/Infinite which we had marked as  $0^\circ$ . We may understand the term 'Zero' or 'Nothing' easily, but what does 'Infinite' or 'Everything' stand for?

We now narrow down our field of analysis to the region of mathematically

$$-1 < 0^\circ < +1$$

which corresponds to

$$10^\infty < 0 < 10^\circ$$

We speak of '-1' as the Relative Infinite and of '+1' as the Relative Zero. Why? It is because there is something more than the Relative Infinite in the region  $-1 < 0^\circ$  and something less than Relative Zero in the region  $0^\circ < +1$ . The point or place where the circle starts and closes is what we called  $0^\circ$  (Zero/Infinite).

So what does actually 'happen' in this field, where Zero and Infinite meet, and which is, incidentally, the place where the underlying and projecting THIRD connects.

### III.1.1 Beyond 'Zero and Infinite'

Our world, the world we live in, is circumscribed by the limitations of Zero and Infinite, Nothing and Everything. Then what could be 'beyond' these two limitations.

Our world, the world we live in, is a world composed of mass and energy, which, as we can see from Figure III.1 above, are interrelated in that they convert from one to another at certain points or regions on the circle. What could be beyond?

We will re-draw our Figure III.1 in a way to hi-light the area  $-1 < 0^\circ < +1$ . Please refer to figure III.2.

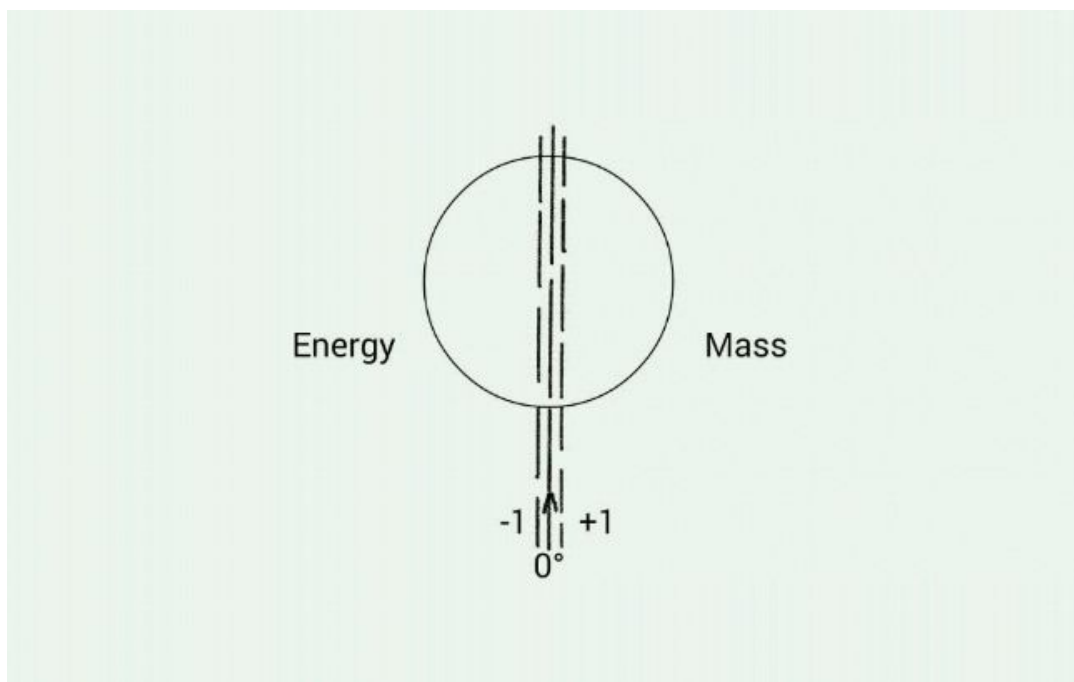

Figure III.2 The Transition Area from -1 to +1



It is interesting to note that there are two energy-mass conversion points, one in the region of -1 to +1 and a second one somewhere on the circle, which is also within a spectrum relative to -1 to +1 at the opposite side of the circle. It is here where the THIRD interlinks with our Universe and virtually holds and sustains it. But WHAT is that THIRD and what is its function and nature?

Let's draw the picture a bit more in detail to get a broader view. Please refer to Figure III.3.

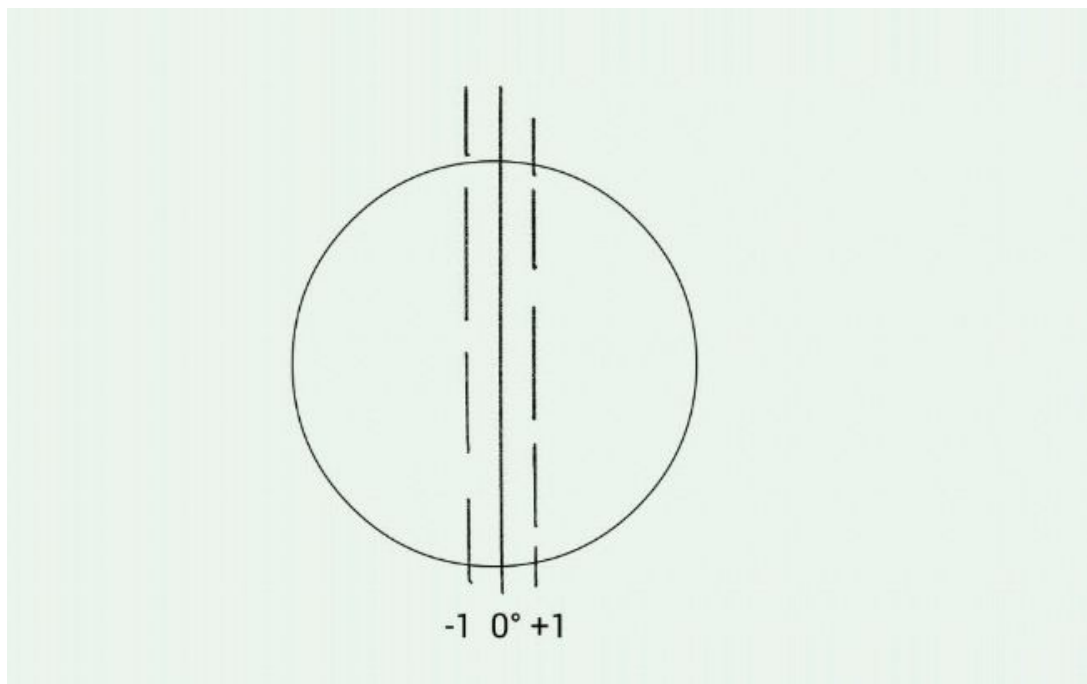

Figure III.3 Close up of 0° Region

### III.1.2 The 'Switch' from Human to Divine Perspective

The typical human being will see in Figure III.3 a circle divided by a main line 0° into two equal halves and one additional line left and right from it marked -1 and +1. What does that mean?

The typical divine being will see immediately, what it is all about, as the divine being KNOWS that the human side is 'in the image of' the divine side. It is all about mirror imaging.

In a mirror the picture shown is opposite to the one portrayed in front of the mirror. The -1 in

Figure III.3 is the mirror image of +1, and so are the two half circles that before we had identified as a full circle. The mirror axis is the  $0^\circ$  line.

A mental switch of perception respectively a switch from human to divine perception!

What does it make human and divine perception? As human beings we were looking at a circle crossed by three lines, absolute, whereas in divine thinking we discovered two half circles divided by a center line, relative, mirror reflections of each other. A main difference between the divine and the human sides is, as already discussed in earlier chapters, approaching things RELATIVE instead of ABSOLUTE; thinking, feeling, and understanding relative versus absolute.

Having left the world of human thinking in absolutes, we engage now in a new world of relativity. We have two half circles relative to a center line called  $0^\circ$  bordered by mirror images of +1 and -1.

### **III.1.3 Our Universe as seen out of the Supra-Divine Perspective**

What is the Supra-Divine Perspective? Effectively it is the Mirror Axis we called  $0^\circ$  in Figure III.3. When we position ourselves on just that Mirror Axis OUTSIDE the circle and not inside the circle, we see, in front of us, two opposing sides that stand as mirror images to each other. In Figure III.2 these two Mirror Images are Mass and Energy.

Surprised? We may have considered mass and energy as absolutes so far and already marveled how they relate to each other within a circle.

Mass and Energy are Mirror Images of each other in a similar sense as Divine and Human are Mirror Images of each other. Their common foundation, the THIRD or The Supra-Divine Sphere is the Mirror Axis of the dual projections of mass and energy respectively the human and the divine fields that not only projects but also sustains the dual mirror images.

When we call one side of the dual projected pair 'energy' and the other 'mass', then what do we call the THIRD?

The third in such context is called MIND. Mind projects, sustains and also experiences the dual world of mass and energy through the portals of the five senses of the human body.

We spoke, much earlier in Part I of this Book of Ultimate Wisdom, of the illustration of a theatre play. There is a front stage and a back stage, a dual pair, set to entertain the audience that also sustains (finances) the play by them buying the entry tickets to the show. Front and back stage, in such context, relate to mass and energy, and mind to the audience that sustains and experiences the show. We also spoke of a theatre administration that attracts the audience by ways of advertising to the show and a building called the theatre building. Latter ones are 'temptation' and 'the physical world', which we enter to enjoy the 'show'.

'Come and enjoy the once in a life time super show', the advertising from the theatre administration may go. 'Enter the realm of a physical body endowed with five senses to really enjoy the virtual show'. Tempted and attracted by such great advertising we enter the physical realm through what is called the medulla oblongata into a human body endowed with five senses and enjoy as audience or even in participation the great show that is enacted here. Mind that got tempted is taken on a roller coaster ride that confuses Mind thoroughly, though Mind is not only experiencer, but also projector and sustainer of the show. We need to find clarity of mind again to see what it is all about and retrace our footsteps past the slogans of the advertisers out through the portal of the medulla oblongata again. Otherwise we'll be on the illusionary roller coaster ride of human existence forever.

Could we participate in roles other than in a physical human body in this Grand Show, too? Sure, we could, as we are the Gods ourselves and as such could participate in any function or expression we choose; it's our choice, after all. Mind awareness, of course, differs in different roles and is the most intense in a human role. Mask and costume of an actor may change, but the actor remains the same; just what the actor acts is different.

Having established yourself in your inherent Supra Divine Consciousness again, you might have even the opportunity to be someone different this very life time, if you wish so. Out of a supra divine perspective everything looks different and there are substantially more choices. Yes, out of the supra divine you have the option to change your role that you are playing here on Earth.

Generally speaking, however, when someone leaves school or university, such person joins the wordly scene in the lowest rank pertaining to the relevant education and 'grows' from there in terms of 'opportunities' and 'promotions'. Similarly, when a soul decides to join the Grand Show, it generally joins in one of the 'lowest' ranks; 'lowest' by human standards only, as in this Universal Setup everything is of EQUAL importance, lest for the want of a small 'pin' the Universe falls apart. Each and every living being is as such an entitled participant of the Grand Show, even beings that by human understanding have no life, such as stones,

metals and minerals. The parts that constitute our Earthly stage are of great importance, too, as without our Earthly stage there wouldn't be any Earthly Grand Show. So, please be respectful to all participants, even an apparently dead stone or piece of metal that is designed to be an essential building brick of that stage. Out of a supra divine viewing angle all that will become clear.

Vegetarians and Vegans are in their own rights, but 'killing' is not the issue out of a supra divine perspective. Even rice, wheat and corn are alive. Putting the seed into a fertile ground, the rice, wheat and corn sprout and create more of its own kind. The issue is the little known 'side effects' of all food items on physical and mental well being of any living being. Here, Vegetarians and Vegans have a point, but not in the much discussed 'killing issue'. The tiger and lion don't commit 'sin', when killing for food. But it is 'sin' to kill out of greed, anger or hatred. Would please all human beings take note of that fine detail.

There are, inherently, people of different 'ranking' in the human structure, but once again, everyone is of EQUAL importance, lest for lack of food produced by the farmer the king starves to death. Clergy, royalty, high class, middle class and worker's class and even class/caste less people all play roles of equal importance; the harmoniously interwoven set up is responsible for everyone's welfare. In such respect, there are no more and less important human beings and the widespread human classifications by class and caste are willful misinterpretations of their relevant Holy Scriptures. Would everyone please take note of that. Out of a supra divine viewing angle such fact is understood easily.

By human standards there are people that firmly believe that 'their way' and 'their culture' or 'approach to life' is the 'best and only' one. Out of the supra divine perspective things look very different here, too. Complexity of this world is such that there are not two blades of grass that are exactly the same and finger prints of human beings are said to be different in every individual. Wouldn't this world be dull and boring, if all flowers look exactly the same? Complexity is the beauty of this World; also in inherent expressions and approaches to life. Out of a supra divine perspective we are all 'crazy' in one way or another, though out of a human perspective we are not aware of that. Rather than competing with each other about the best and only way or expression, let's move in consciousness into the supra divine sphere and have another look at things from there: Only then we shall understand.

So discover your inborn divinity, beyond the human realm, and your inborn supra-divine nature that is, essentially, the projector, sustainer and enjoyer of the show. In clarity of mind you will be able, once again, to identify and position yourself correctly and view things from the appropriate perspective.

### **III.1.4 The real Us or Me**

Then WHO is the real 'us' or 'me' in the world 'beyond' the theatre? The real 'us' or 'me' beyond the theatre is an entity called SOUL. Soul has a Mind and that Mind got tempted to enter the realm of a human body drawn by the great advertising. Within the realm of the human body and distracted by the great show enlivened by five sense experience mind got confused and, slowly or sometimes quickly, forgot its inherent nature and being and identified itself with five sense experience. The experience became 'me', the physical body became 'me', the five sense limitations became 'me'.

Then who is me 'really'? The real 'me' in such context is the Soul. As long as the mind is confused the Soul identifies itself with the physical body and the ongoing show. Mental healing is all that is required to see things in their correct perspectives again. Positioning oneself on the mental realm and watching the interaction of mass and energy out of such perspective without actual engagement and interaction out of oneself, mind finds back to itself. Can you see things clearly now?

### **The World outside the Big Show**

There is a big building in our town that we call the Theatre Building. We enter such building to enjoy the show, attracted and drawn by great advertising. We are sort of 'not ourselves' as enraptured we enjoy the show, aren't we?

This, our Universe, is none else than a small balloon or bubble floating in a much vaster world that is shielded from our sight by an invisible shell in a similar fashion as the walls of the theatre building in our town prevent us from looking out of the building during the show.

By the standards of the vastness of our town or country, that theatre building, though relatively big compared to other surrounding buildings, is almost negligible small in size. And so it is with our World and Universe; it's almost negligible small in size. Just in our minds it is huge and gigantic.

We can't get out of our earthly theatre building by just 'breaking through its big walls'. We have to find our way back to the door through which we entered, likely in pitch darkness, if

we choose to leave during the show. Similarly, we have to find our way out of the appropriate door through which we came in, the medulla oblongata in the human body. If we choose to blow up the theatre building to get out, we may find ourselves trapped and buried inside. Similarly, take care of your human body so it lasts till you manage to get out of the medulla oblongata exit door again or you might find yourself trapped and buried in a world that is an inherent part of the theatre play. Call it heaven, call it hell, call it paradise or whatever; it's still an integral part of the theatre building with its limitations. You will need to be able to exit consciously through the gate of the medulla oblongata of your human body, without any binding attractions and attachments to the virtual world of show, or else you may find yourself trapped inside the labyrinth of physical existence and/or be tempted, once again, to go back to 'enjoy and participate' till all your 'sins' are compensated for and all attachments have been cleared.

## **III.2.0 The World around us as seen from the Supra-Divine Angle**

We will position us now, in the following, in the Supra-Divine Sphere OUTSIDE the circle and have a look back at what we see. That is a different view to the human perspective that typically takes a one-sided view of things out of some corner in absolute terms. Consequentially, the logic is also a different one. When we base our logic on one-sided views out of selected corners, perhaps starting with ourselves and the way we view ourselves, then things look entirely different from us taking a universal approach as a virtual outsider. As an outsider, like in the third angle or supra-divine position outside the circle, we have a comprehensive overview of things in their entirety. We are then no longer bound by existing human or divine knowledge and experience and thus can reach far beyond that. An even broader view we could afford us, if we position ourselves even further beyond. But that's a step too big to take at this present moment. Therefore we analyse and discuss out of the 3rd angle or perspective at this stage.

### **III.2.1 Mind and Body**

The world as we see it is a combination of mass and energy. The driver as well as experiencer is something that we have called 'mind'. What is that 'mind'?

The body is a combination of mass and energy that is penetrated by mind. Mass and energy are ever interacting and mind is sustaining and experiencing. At death 'mind' withdraws and without sustenance the body falls 'dead' though both energy and mass are still present. At death not only mental sustenance goes, but also mental experience. Dead people loose the five sense experience of the body. One could illustrate that as 'the audience leaving the theatre'. But 'leaving the theatre' doesn't mean that the audience has died, hasn't it?

We are afraid of death, because we don't know what is happening here. Positioning ourselves entirely on a physical plane, we think we are the body. We may grow to understand that we are both body and energy, ever interacting with each other, and still fear death, as in death sense experience goes. Then what are we?

If we can position ourselves in mind and watch the mass-energy interaction as a lovely entertaining play and the human body as a simple means to facilitate that, then well be 'awake' when the time comes for mind to withdraw. Then death will be something totally normal and understandable that we easily can relate to.

Then what happens after death? Well, what happens after the theatre show, when the audience leaves? There will be some break and the next day the show continues, perhaps to entertain some other people. And over time, the same people that attended the earlier shows may come again as the program keeps changing. So we'll be back, earlier or later, depending on how we feel. Such 'feeling' is buried in mind and it's mind that seeks further participation and entertainment in the show. That is called 're-incarnation' and we ourselves 'in mind' beyond earthly death are the decision makers on how it is supposed to continue. It is only, when we can make ourselves 'free of mind' and its attractions and compulsions that we can enter the higher soul consciousness that is capable of withdrawing itself from the smart advertising campaigns of the 4th, the so-called temptation, that lures mind to enter the thrilling experience of a human five sense world once again. In mind-consciousness we are likely to enter this world again and again, as it is devised to attract and entertain mind. In soul consciousness we can see the 'big picture' including the smart advertising that keeps us getting tempted to participate over and over again. Isn't that very similar to how worldly advertising works?

### **III.2.2 Sense Experience**

The THRILL of earthly existence is Five-Sense Experience. There are seeing, hearing, tasting, smelling and touching. If we have ever been to the movies this early 21st century of the Christian calendar, we have experienced 'movie' in an audio-visual style. The hype these days is the introduction of a digital sound and three dimensional vision experience. That alone is thrilling, and still, there are only two senses involved so far. What if we were to add just smell to that? How would be an audio-visual sense experience in digital 3D perfection that also involves our sense of smell? Or, if the movie world could add the sense of 'touch', us feeling the heat of the fire and the cold of the ice and the breeze of the wind and the warmth of the sun that the hero in the movie is feeling at some given moment. Presently that's left to imagination, as only two-sense audio-visual movies can be made. So the future may have some surprises in store for us.

An interesting aspect in the five-sense experience is taste. We taste, when we put something on our tongue. We usually 'taste', when we eat and drink. If there were no need to eat and drink, we were deprived of the sense of taste. In such context mind is not the sole sustainer of the mass-energy entity called body. Food and liquid are a necessity, though the main sustainer still is mind. We could, in theory, live on mind alone, but then we would be deprived of that lovely taste sense experience going hand in hand with smell, sight and touch.



### III.2.3 Sustenance

While 'mind' is capable of sustaining us comprehensively, arrangements are of such nature that a small percentage of sustenance comes from food and liquids. How would your world look like, if there would be no need to eat and drink and the sense of taste be wholly excluded from your life. Wouldn't you feel deprived?

Due to the dual nature of our world, sort of mirroring on mind, each food and drink item we consume is of dual nature. Wherever there is sustenance, there is the opposite called destruction. We need to be very careful to choose what we put on our tongue and things that are the most thrilling in sense experience could also be the most destructive.

The human body is a delicate balance of mass and energy interwoven. If such balance is thoroughly disturbed, we may fall sick. It is interesting, in such context, that sickness or illness is not absolute, but relative like everything else. Health and illness are a relative sense experience of what we consider healthy and our mind is bendable and adjustable. We may consider minor issues as life threatening and major issues as harmless. What is getting disturbed is the harmonious mass-energy interaction of the body that sustains so many functions to make 'life' in a human body feasible in the first place.

We may fall sick sometimes. How does it feel to be sick? How do we know that we are sick?

There may be some signal from the body cells called 'pain' signalling that something is wrong. Mind as the sustainer and experiencer gets alerted to some misalignment in the mass-energy balance of the body. What we will do at such stage largely decides how things will develop from here.

How do we deal with pain? Do we consider 'pain' as a friend or a foe? If we consider 'pain' as a friend, we should follow up the cause of pain and rectify the mass-energy balance immediately. If we consider 'pain' our enemy, we may simply try to suppress pain so we can carry on with our life.

The danger of suppression in medical issues lies in ignoring the mass-energy imbalance that now may increase and eventually become life threatening. Still, in this so-called early 21st century of the Christian calendar, suppression of warning signals or symptoms is still the most popular approach of dealing with such imbalances. Then we don't need to wonder that serious diseases like cancer, diabetes, tumors, heart and lung disease and so on are wide

spread these days. We have ignored the early warning signals of the touch sense that delivers pain and dealt with symptoms in radical ways rather than constructive ways that promote healing of the underlying conflicts in the mass-energy balance within.

Why do we risk our life and existence on Earth by using brute force to get things our way. Well, we likely do that, because brute force is used everywhere in our life; survival of the fittest, as the motto still goes in many parts of this world. We seek to survive by brute force when things don't go our way. So brute suppression of the body's warning signals in pain and symptoms is a reflection of our inherent nature. Unfortunately, we can't get away with such brute behavior, neither in the inner world of bodily health nor in the outer world of universal justice. As we sow, so we will reap.

### **III.2.4 A look at the health scenario from the supra-divine angle**

We assimilate and excrete and all is about BALANCE. But when this balance is getting disturbed, for whatever reasons, we say 'we are sick'. In such sense sickness is nothing else than a disturbance of that balance.

We have the three elements of mass, energy and mind. They harmoniously interact with each other and establish and maintain that balance. If an imbalance occurs, we have, as such, three practical means to influence and re-establish that balance. We speak of physical healing, energetic healing and mental healing.

Physical healing, in such context, does not necessarily mean that we heal just the body. The body and mind are interwoven and can't be separated from each other. It is all one big system and whatever external means we apply towards change or improvement of some ill condition, also affects all the other parts in such game. We can't separate the mind from the body, nor can we separate the arm from the leg. They all are an integral part of the same system.

When we speak of physical or energetic or mental healing, then it means we are employing means from those areas: Physical Medicine, Energetic Processes of Healing and Processes of Healing that are neither physical nor energetic.

We have learnt already that MIND is both the projector, sustainer and experiencer in this play. As such, MIND is the best player to maintain the balance of mass and energy. If we could work directly through mind from the 3rd level, we won't need any other forms of healing.

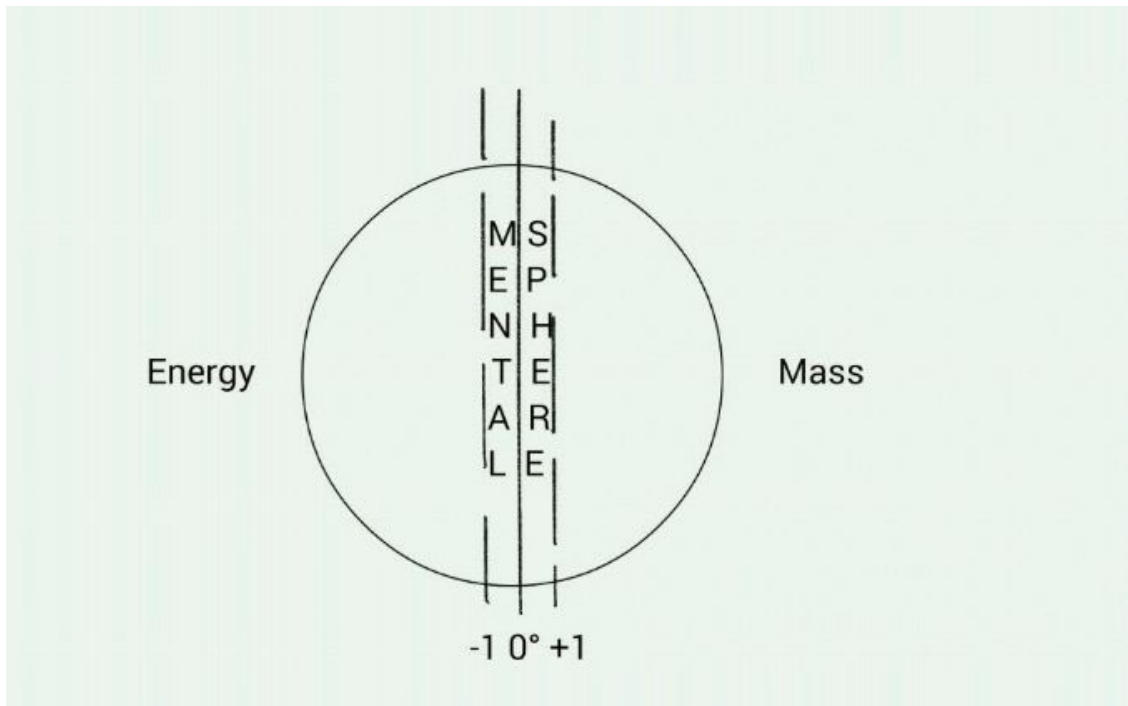

Figure III.4 Mind-Energy-Mass Interrelationship

We can see from Figure III.4 that mind is essentially the mirror pane of the two projections of energy and mass. But mind also penetrates the entire system at both ends of the circle having an origin and an end. Where is the origin and where is the end? Simple, where the origin is there is the end. Mind, once again is circular. Mind projects, sustains and experiences, but where is that power that facilitates mind to do that, if not on an even higher plane. If we were to control mind from that higher plane, consciously, we would be able to heal ourselves from all maladies through mind. As we are not yet able to do that, we have to employ inferior ways of healing, such as physical and energetic means.

We can also see from Figure III.4 that the mental sphere is located between  $-1 < 0^\circ < +1$ . If we were to find a remedy that could interact with and through mind in this region, we could do a lot of good to ourselves. The region is essentially the one earlier discussed:

$$10^\infty < 0 < 10^\circ$$

Within this region we could achieve an almost infinite power of healing by weakest physical and energetic means. The highest power of healing is achieved around the point  $0^\circ$  and that power slowly reduces, when we move away from  $0^\circ$  to either side. Outside the  $-1 < 0^\circ < +1$  region, the healing power achieved by physical and energetic agents is less and we would have to resort to much higher energies and physical dosages to influence and, in such context, then virtually overpower and force mind to our intended aim. Overpowering is these days still the most common approach to dealing with ill health: Forcing the issue, as habitually we tend to 'force the issue' in so many ventures of our daily life's affairs as well. Unfortunately, forcing the issue, we can cause great damage in related areas, the so called side effect, as we are speaking about 'balance' and an action of ours generally has dual consequence. That's due to the nature of our Universe that is laid out dual in nature. We would be therefore best advised to keep the strength of our actions in limits, as pushing one side hard we could easily 'derail' the another one.

If we could devise medications that are physically and energetically in strength close to Zero, but not Zero Absolute, we could enjoy maximum benefit without those unwanted side effects, as small power action also brings small power side effects. Unfortunately, in our present ways of human thinking, we still believe that small action also brings small reaction. This may be so in terms of mass and energy, but it isn't so in terms of mind. Mind projects, sustains and experiences subtly. So, if we could gently stimulate such mind within its own sphere close to  $0^\circ$ , then we would effectively employ mind as the actual healer through the ongoing projection, sustenance and experience process. Remember, mind created the physical body and the God, of which religion speaks, only created the 'facilities'. Out of a higher plane beyond mind we are the creators of ourselves. Our means of creation are limited to what that God of Religion has thought of as a 'facility' in the first place. Now, on a lower level of knowledge and understanding, we are also limited in the means of medication. Once we have learnt to establish ourselves on a level BEYOND mind, we could conveniently also act THROUGH mind. At the present stage we can't do that, unfortunately, but we can GENTLY influence mind, if we know how to practically do that: Limited force stimulation rather than high force suppression.

### **III.2.5 Healing through GENTLY stimulating MIND**

In Figure III.5 we graphically find the relationship between Power Employed and Effect Achieved, when using physical or energetic means to stimulate mind to effective healing.

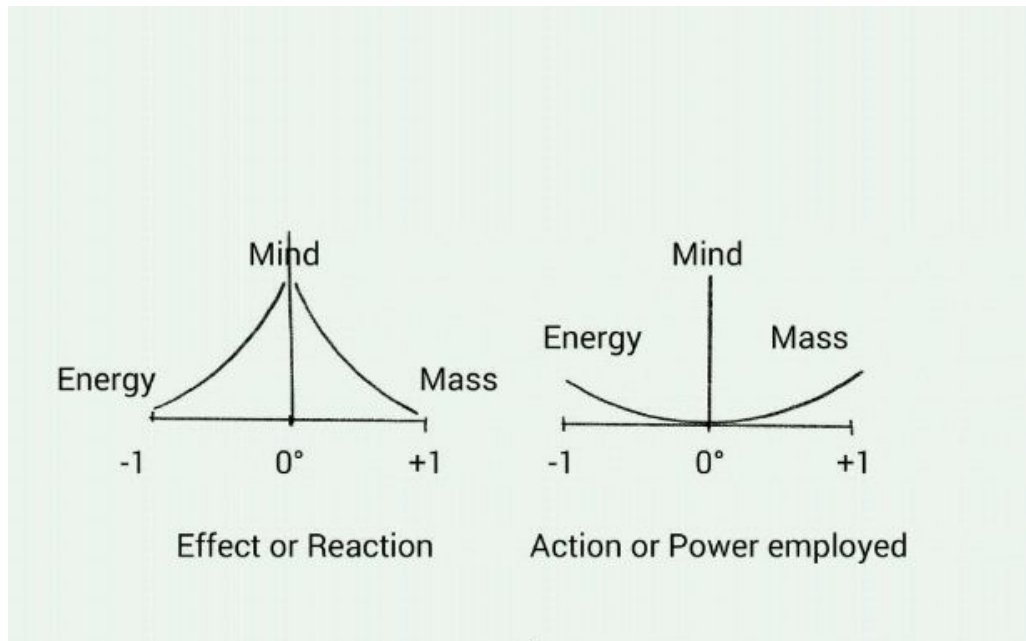

Figure III.5

The Relationship between Power Employed and Effect Achieved in Mental Healing

As we are getting closer to 0° the effect of healing increases, whereas the power of the physical or energetic means needed decreases. What does it mean 'stimulating mind'?

Stimulation is the OPPOSITE of suppression. Stimulation means, in such context, that we are increasing the mind's awareness to an existing problem. So, if heat is the problem, we slightly increase heat instead of suppressing by applying cold; if cold is the problem, we slightly increase cold instead of suppressing with heat. The emphasis is on SLIGHTLY here. No brute force is to be used under any circumstances or we'll do damage.

Millennia ago, the sages advocated Chilli-Spice to cool the body when overheated. How come? Isn't chilli is a heating agent? The instruction was to use a VERY SMALL amount of chilli, of course, which is effecting a slight increase in heating. The emphasis was on 'slight increase', of course. People, in a consciousness and habit of always using brute force when things were not going their way, reasoned falsely that, if a small amount is good, a large amount would be even better. Interestingly, in warm climate zones chilli is used in abundance these days, effectively overheating the body system, when cooling would rather have been appropriate.

So, when we talk here about 'stimulating mind', we mean 'slight increase' of what is the disturbing factor, instead of applying the opposite, which would then amount to 'suppression'.

### III.3.0 The Nature of Mind

We mentioned in an earlier Chapter of Part III of this Book of Ultimate Wisdom, which we by now also could circumscribe as 'Book of Universal Wisdom', that mind is circular in nature. What does that mean?

It simply means that mind has no start nor an end except that one could say 'where it starts there it ends'. This also implies that there is an  $-1 < 0^\circ < +1$  on the mental axis as there was on the mass-energy circle (axis).

Our earlier drawn Figure III.4 changes now to look like Figure III.6 below.

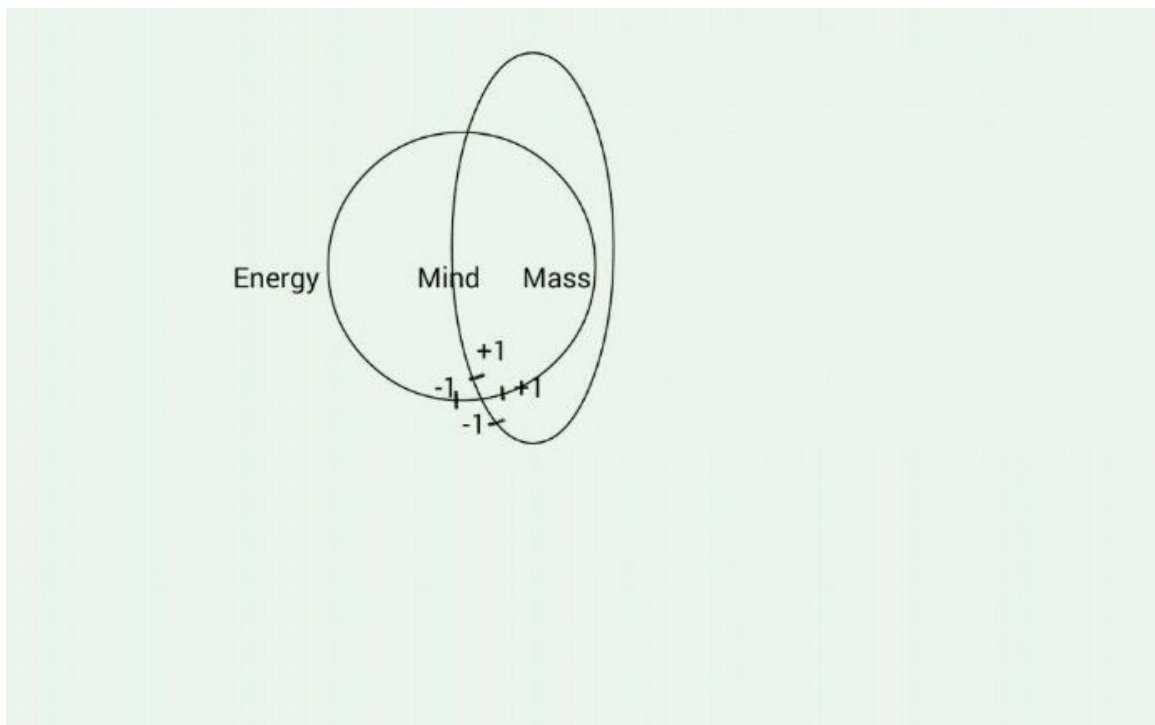

Figure III.6 Mind in its circular Nature

In terms of balance, which is the foundation of our Universe, we may logically conclude from Figure III.6 that there must be a Parallel-Universe to ours of mass and energy of an inverted nature that mirrors on mind on the other side of the circle. Both Universes then would be mirroring again on a common something. Scary thought?

If we'd draw our Universe as an upside pointed triangle setting 'E' for energy, 'P' for mass and 'M' for mind, we find the 'Beyond' looking something like illustrated in Figure III.7 below.

What is the 'Beyond'? Simply, it is the mirror axis on which the two Universes mirror, ours and the equivalent 'Inverted Universe'. There is 'much more out there' than our human perceptions could even marvel about. Why don't we start the journey of exploration into and from our mind into wisdom and understand what lies well above our present shores?

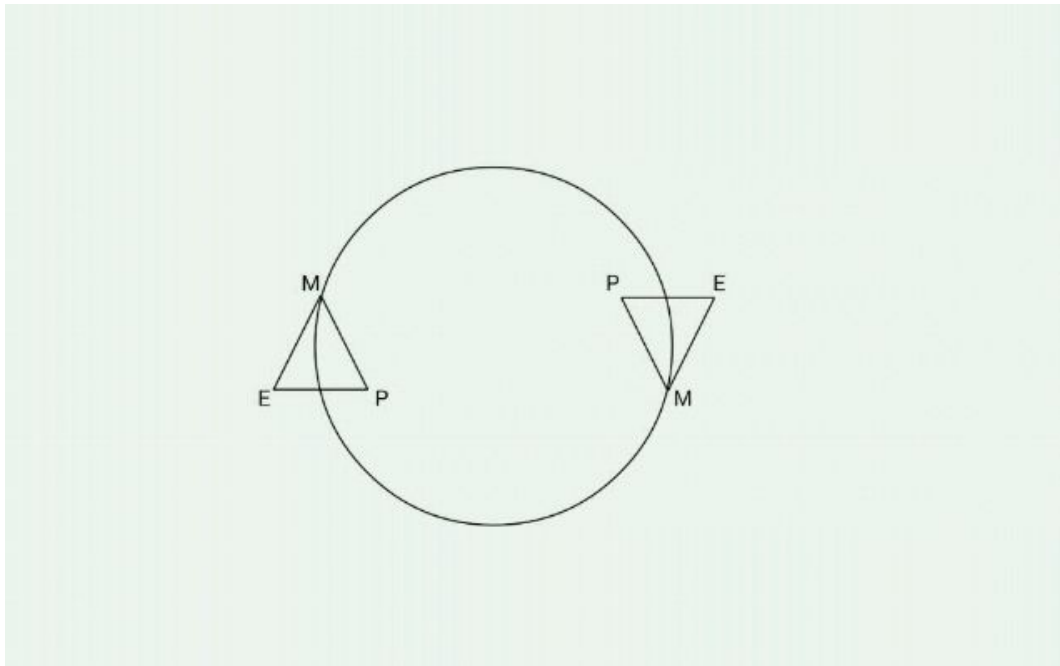

Figure III.7 The Parallel-Universe to ours of an Inverted Nature

Doesn't the picture in Figure III.7 look somewhat familiar? Yes, it is again that Philosopher's Stone Saga of Part II of this Book of Ultimate Wisdom. It is all about mirror reflection, here and beyond.

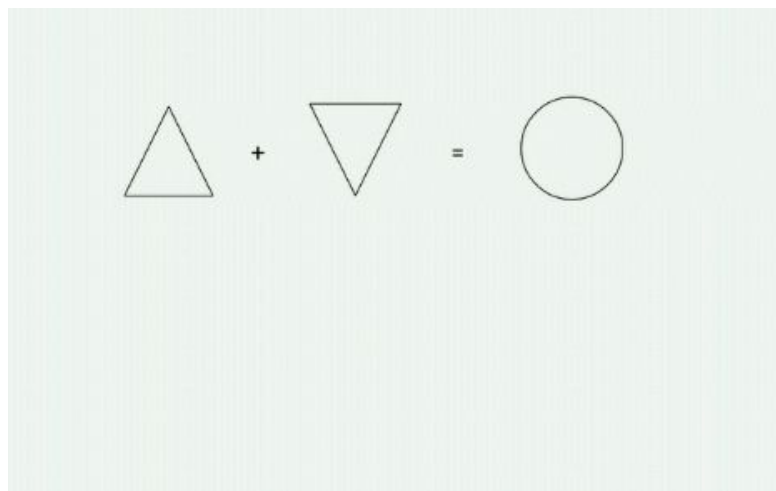

Figure III.8

The Philosopher's Stone's Equation

What does it mean here that the two inverted triangles added up result in Zero? It simply means, if we add up the two Universes, ours and the Parallel-Inverted one, the circle is closed and only the 'Beyond', the Mirror-Axis to both Universes, remains. So there could be another 'Beyond' after the 'beyond'...

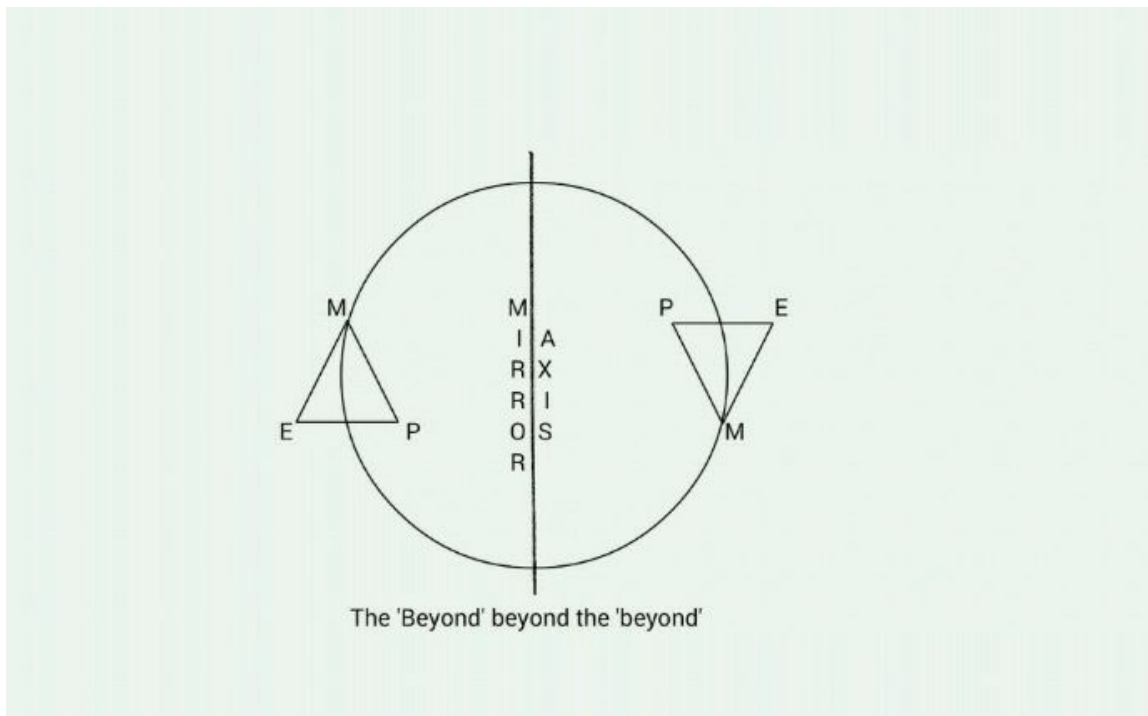

Figure III.9 The Mirror Axis to the two Parallel Universes

Is this finally the 'end of it'? Not necessarily, as the mirror axis to the Universes could, once again, be circular in nature, and mirrored on a 'Further Beyond', there are 'two inverted sides' on just that circle, of which one we have already identified in Figure III.9 above.

If we combine the two sides in Figure III.9 into one symbol, we would find two inverted triangles moved into one, but would have to come up with a new symbol to describe 'inversion' of the two inverted triangles. Let's use an upwards pointing arrow to describe the two triangles of Figure III.9 moved into one.



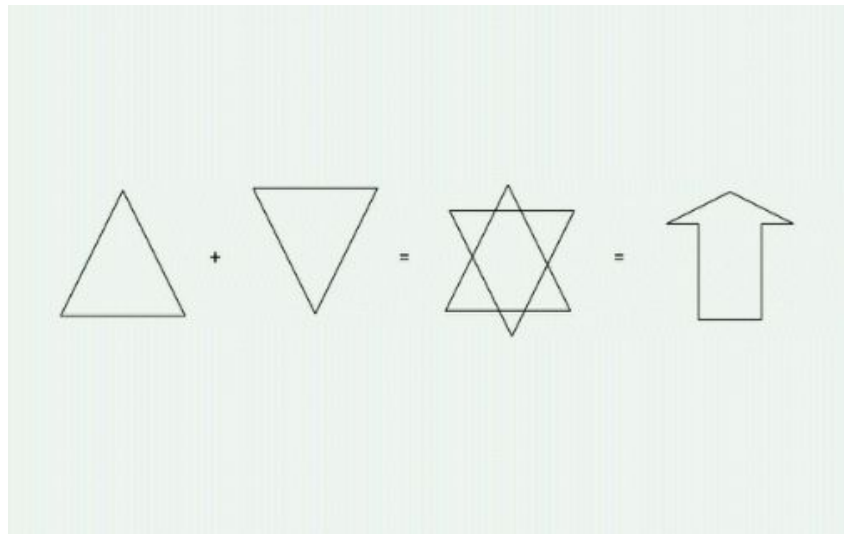

Figure III.10

Describing two inverted triangles as an up-ward pointing arrow

Now, we proceed, as before, and show the mirror axis of Figure III.9 as a circle, on which there is an upwards pointing arrow on one side and a downwards pointing arrow (inverted to the first one) on the other side. Both sides on the circle are, once again, mirror images to each other that reflect on yet another circular mirror axis in the middle. Please refer to illustration in Figure III.11 below.

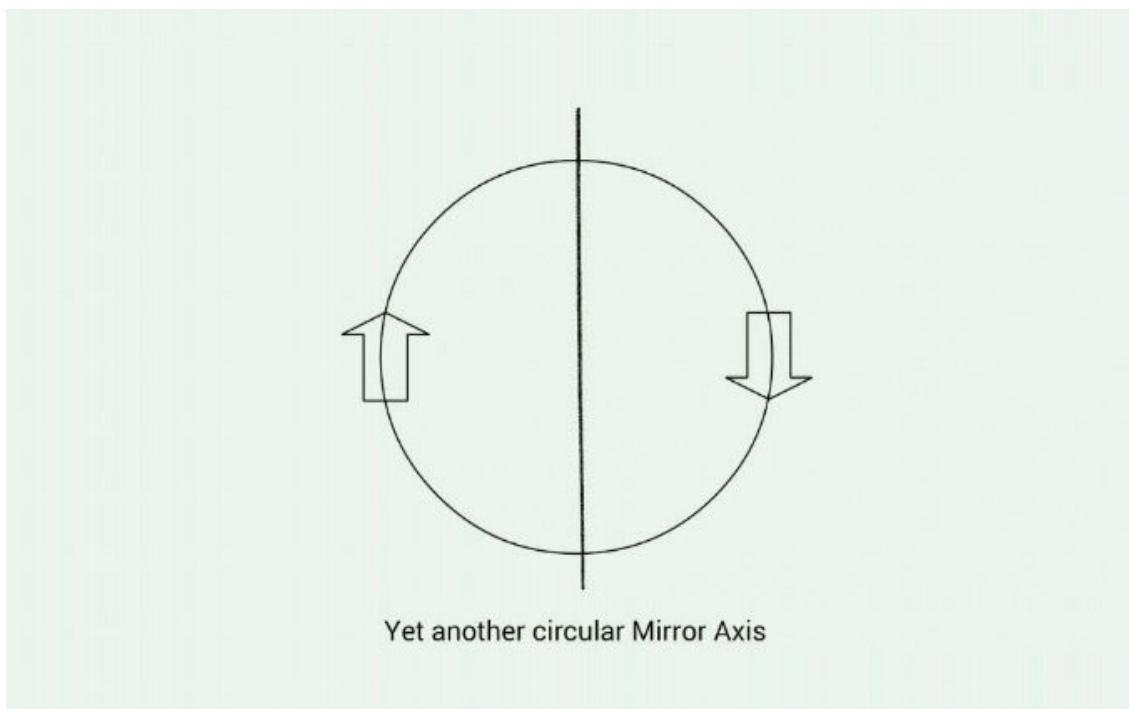

Figure III.11

Mirror Image over Mirror Image into the Beyond

And so it goes on and on and on. We may have noticed that there is an increase of 'Beyonds' involved in this, as each 'Beyond' is vaster than the previous 'Beyond'. That's the clue! We are running once more in a huge circle in which the end is where we started.

That's the nature of our mind. It's a huge maze of ever enlarging mirror images whose axis in itself constitute a circle. If we continue to explore mind, we will be 'running in circles' forever. The trick is, not to explore mind in all its amazing worlds, universes, beyonds, and constellations, but to leave mind with all its fascinations behind and move 'out of mind'.

Going back to the earlier illustration of a grand theatre building, we can err through its vast corridors forever and discover ever new fascinating things. The trick is to find the exit door and leave that grand theatre. Temptation is ever present and fascinating seeking to keep us inside. We need to overcome temptation and get out. As in the huge theatre building, so within the human body; we must leave mind with all its attractions and temptations behind and slip out of the exit door, while still alive. Once physical death catches up with us it is too late. We must move 'beyond and out of mind' as long we are still capable of doing that.

The Philosopher's Stone Equation remains valid for the entire journey through mind, in a full circle from the start back to the start. As helpful as the Philosopher's Stone was in the beginning, as distracting it can be towards the end. Eventually, having used it plenty to understand, we must leave it behind.

Please remember a great wisdom in this respect: Whatever was of greatest help in the beginning, could be the greatest distraction towards the end. We must move ahead, eventually leaving behind what we treasured the most. Why? It's 'Mirror Imaging' of Start and End!

### III.4.1 Methods of Healing

We must admit, we aren't well. Getting the courage to admit that is the first step to healing. How can we be sound and well, if we don't even understand our basic nature and how we ended up inside a human body? How can we be considered healthy, if we blunder around in this world trying all sorts of medicines and remedies hoping they will do us good? If we were only able to see things from beyond, it would be so easy 'to fix us up'. But, alas, we see ourselves from down and pray to someone 'up there' to make us well, be it a doctor or a God.

Looking from the supra-divine perspective we'll understand our illness and what is necessary to get us well. For the first, there is mental confusion in that we see ourselves as helpless human beings, when in reality we are Gods, indeed. Then, why we approach our earthly problems from the angle of a human being, when we could approach things also from the angle of a God.

Mind is the projector and sustainer and not just the experiencer. So all we need to do is interact with mind in feeding mind with the appropriate information about ourselves. Mind, unfortunately, is a slave to habit and can portray an unhealthy state as 'normal' and 'balanced', when in all reality it is not. That's when we are 'habitually unwell'. Perceiving ourselves as human beings, when in all reality we are Gods, is such a state of being 'habitually unwell'. We must therefore find appropriate means to 'shake mind out of its comfort zone'.

Mind, in its inherent nature, is a most sensitive instrument of projection, sustenance and experience. Therefore 'shaking mind up' doesn't mean using 'brute force'. It rather means 'communicating with mind' in forms of 'feed-back' and 'gentle stimulation'. Naturally, mind is bound to resist and persist in the established form of habit. But we can stimulate mind in a way that mind 'resists' into the direction we want mind to resist to. If we stimulate 'down' from the established comfort zone, mind resists 'in upwards direction' and if we stimulate 'up' from the established comfort zone, then mind resists 'in downwards direction'. But such 'opposite directed form of resistance' will only be effective, if the stimulation is gentle. If we use brute force, we can overpower mind to respond 'upwards' when we stimulate 'upwards' and to respond 'downwards' when we stimulate 'downwards'. But, as all consequence to action is of dual nature, the backlash from forcing things into one direction may be a very painful one. Stimulating gently also incurs backlash, but it will be a gentle one, as we stimulated gently.

We frequently hear the comment from practitioners that some medicine or remedy is without

any side effects. That's not correct. All action, and taking medicine or some remedy, whichever its origin or nature, **is** action, has dual effects. The effect opposite to what we intended to achieve is the backlash or side effect. The same goes for food and liquids. We'd therefore be advised to choose medicines, remedies, food and liquids that are gentle in nature and stimulate opposite to the direction of our intention. Mind then will respond into the direction of our intention. That's the most appropriate way of healing.

### III.4.2 The Nature of Action and Consequence

The nature of action and its dual consequence are illustrated in Figure III.12 below.

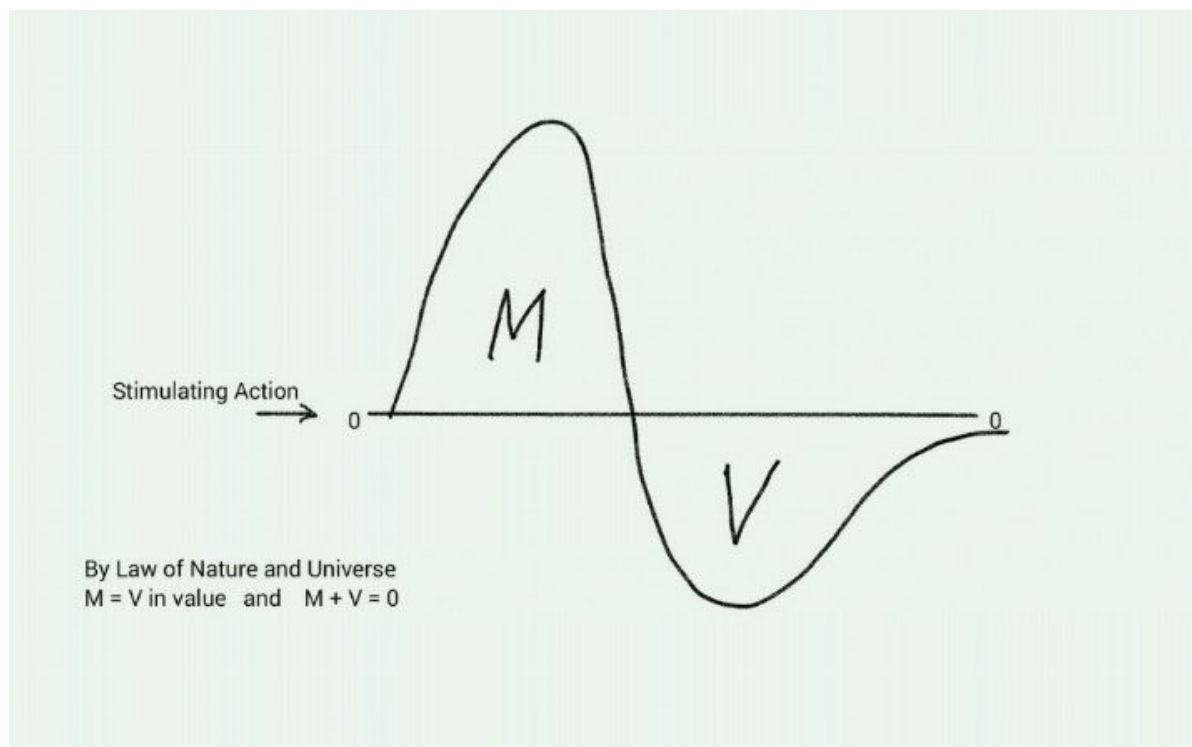

Figure III.12 Action and its dual Consequence

How can  $M = V$ , when  $M + V = 0$ ? Simple, not only value, but also 'direction' is involved. Just by value  $M = V$ , but also including 'direction'  $M + V = 0$ .

We are living in a dual world, based on a 'Third', which is the common denominator to both dual expressions to a point that we could say that the 'Third' projects the dual pair. If we'd take the Zero-Line in above Figure III.12 as the common denominator, then both M and V are virtually the dual-projections into opposite directions out of that Zero-Line. That's the simple

clue to understand and approach the expressions of our Universe. What we see are dual-projected expressions into opposite directions out of a 'Third' and it is up to us to find or discover that 'Third' to understand what is actually happening here. That's the actual clue, which we find, when using the legendary Philosopher's Stone and therefore we are well advised to use it plenty in learning to understand our Universe and our existence therein. Within such framework we can also see now that all action has dual effect, as the activation of the Zero-Line creates the two opposing sides of 'M' and 'V' in Figure III.12 above. In the finals all goes back to where it started and as such the circle closes. Where it started there it ends - and Zero and Infinite are the same point.

### **III.4.3 The Law of Cause and Effect**

What was shown in Figure III.12 as the division of a neutral 0-Line into a dual projection of 'M' and 'V', one up and one down in direction, is the very law and nature of the Universal Law of Cause and Effect.

How did it all start, once upon a very long time ago?

The Gods, individualised beings projected out of a yet 'higher something' without individuality, one fine 'day' sat together and proposed to have 'some fun'. There was a vivid discussion among those Gods, like there might be a vivid discussion among the actors of a theatre play or movie set, if they are being asked to stage their own show of their liking.

There were some basic guidelines given: That 'show' to be staged should be based on 'fairness' towards all participants and there should be no change over all, meaning where it started there it must end. From there on the ideas of the many God-Actors of such play were put to practise. But, what is the fun, if the God-Actors were conscious all the time that it all was to be just a 'play for fun' with all participants aware at all times that they were Gods, indeed, and all was just a fictitious set up. 'Let's forget that we are Gods and play in a state of ignorance of our true nature and being', one of the motions suggested and such motion was carried by a vast majority. 'Just for fun, but in all fairness to all participants and where it starts there it will end' in ignorance of one's own true status of being both the creators and the players of such game!

We can see from those settings that ignorance and mind confusion have a practical purpose. Where such innovative play was going to go, if all players knew it just as an entertaining play

with ultimately no achievement overall but just having fun? We struggle so hard on Earth for 'achievement' ignoring even the most simple fact that we can't take material things with us at physical death. But the practical lesson is that by such nature and behaviour the play is perpetuated and propelled forward. If we all were self-realised Gods here on Earth, then where such play was going to go? We might get quickly bored of things and opt out of it again.

This Book of Ultimate Wisdom, as such, is written predominantly for those who consider to opt out, while those who are eager to 'play-on' might not even want to look at this book, as it is revealing what is really going on and as such perhaps is a 'spoilsport to the play'. So, dear reader, don't be surprised that the perhaps vast majority may never be much interested in such universal wisdom, as the play in itself is the most thrilling to entertain and participate in.

### III.4.4 In all fairness and where it starts there it must end

We can see from that simple definition, as shown in the headline above, how the Universe of ours is structured and organised, in simplicity, and how things work. All consequence to action is of a dual nature that consequence ultimately, not necessarily immediately, is compensated for. Why? That's what ultimately 'fairness towards all players and participants' is all about.

We start from a neutral middle position and then all action is subject to dual effects to a point that in the finals we end up on just such middle position again, as graphically shown in Figure III.13 below.

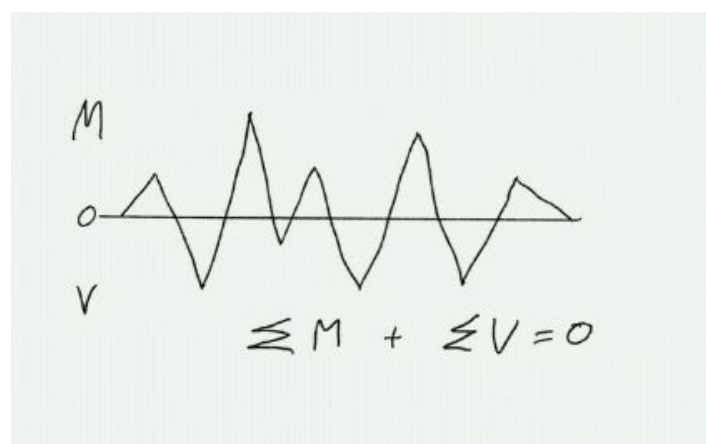

Figure III.13 The Law of Cause and Effect  
'In all fairness and where it starts there it must end'

The sum total of all action consequence into 'M' direction is equal in value to the opposite directed sum total of all action consequence into 'V' direction and as such the equation of the legendary Philosopher's Stone stands fulfilled:  $M + V = 0$

Then, how we'd get out of such entertaining play somewhere midplay? Simple, we must genuinely investigate, where we are actually standing in that play in terms of the motto 'in all fairness and where it starts there it must end'. We then must take the appropriate steps and 'corrective actions' to get back to the middle line where it all started. If we call the middle line the Zero-Line, we simply must head back to Zero. That's where it all started and that's where it will end. Once this simple rule is met, the equation of the Philosopher's Stone stands fulfilled, and we are 'out' with the option to start all over again or simply stay out. We are God's overall and just have 'temporarily forgotten' that we are Gods and participated in the play as 'ignorant fools'. But that doesn't mean that we have to remain 'fools' forever. We can get out. We just must know how to go about that.

### III.5.0 Close to Zero and Infinite

Close to Zero and Infinite; isn't that a contradiction? From our common human understanding Zero and Infinite are opposite ends of a long line that starts in Zero and ends in Infinite. That definition is correct, no doubt, but things are circular and not linear in our Universe. It's just that the 'line' is so long that it appears linear when actually it is circular. The diameter of such circle could be said to be infinite. At such point, where the two ends of the circle meet, is both Zero and Infinite. In the following we would like to have a closer look at just that point we earlier called  $0^\circ$  (Zero-Infinite).

A photograph of a piece of lined paper with the handwritten mathematical expression  $10^\infty < 0 < 10^0$  written in black ink. The paper is slightly tilted and has a light blue background.

Figure III.14 The Area of Consideration

We have earlier devised the area close to Zero as +1 and the area close to Infinite as -1. What is happening within such area or region. Two ends of opposite proportions are meeting just like the two sides of a mirror picture meet on the mirror axis. That's the clue; we are talking about mirror effects here. There are two sides co-joined in a circle that are none else than mirror reflections of each other and the dual reflection is projected out of the mirror axis.

We earlier explained that in our Universe the dual projection is nothing else than mass and energy, which are co-joined in a circle in such fashion that mass and energy are nothing else than a dual projection out of the mirror axis in the center. The projector is called MIND.

The world in which we live as imaginary human beings is just an illusionary set up projected out of MIND; illusionary in such respect that MIND made the entire thing up and sort of hypnotised itself to believe it is real. So, in MIND things are real, but outside or beyond MIND things are just illusionary. They are just fiction.

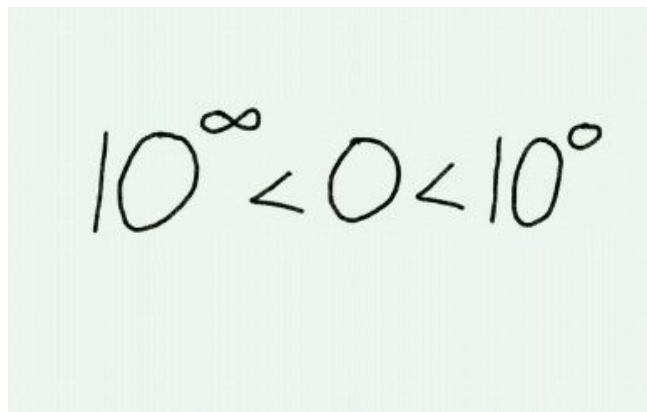
We are sort of imaginary beings projected out of MIND who firmly believe in their existence,



because MIND has hypnotised itself to believe that. If we were to make up such an illusionary world inside a computer, the beings inside that computer would be wholly convinced of their existence, while the computer operator knows that they are just the fictive projections created out of a cleverly arranged computer program. How does that make you feel? Remember, please, that you were the computer programmer yourself and you yourself have hypnotised your mind to believe in the whole story that you have made up. You are your own creator and only you can get yourself to snap out of that illusion again by reaching beyond MIND and take up the controls again. At present, however, you as a human being are controlled by MIND to play such role as you yourself have programmed as the operator. You need to switch from Player to Operator Status and then you can see such set up clearly out of your own self. You did that just for fun, perhaps to just play a prank on yourself, and there is no one else to blame except yourself having devised that illusion for yourself. You are the God that created that and only you can snap yourself out of it again. No one can do that for you except you yourself, if you really want and feel ready for that.

We will now have a look at the entire set up out of Operator Perspective beyond mind. What does the Operator see that we, under the spell of Mind, can't see. Ready for that?

### III.5.1 The Operator Perspective

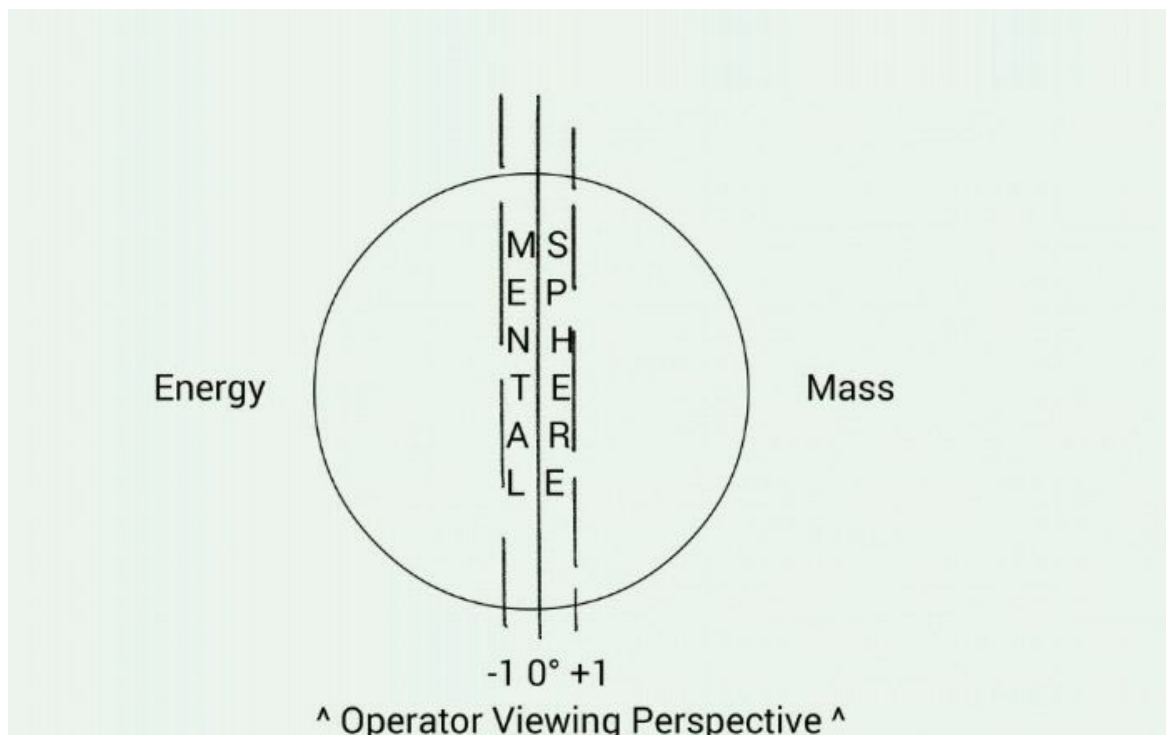

Figure III.15 Operator Perspective

The 'Operator' is the one that has programmed the mind to create and finally firmly believe what mind has created being true and real. So mind is in limbo and won't get out of the illusion unless you, realising the mind's problem, move back on to the 'operator chair' and re-program mind. It's your mind and you are the operator, none else. So only you can take such initiative for yourself; none else.

Figure III.15 illustrates in which controlling position you should be. Presently you are still lost in the dual mass-energy play. It's up to you to snap out and get back to the controls out of the operator perspective as shown. Then and only then you'll be the 'Master of your own Destiny'.

In other words, get out of that mirror, the dual mass and energy play, and be the Controller.

### **III.5.2 Back at the Controls**

Okay, we have made the crucial switch, from the 'projected state' back into the 'operator's chair' and are back at the 'controls'. We've experienced the projected state and all its shortcomings and confusions of mind and now we can 'reprogram'. Or we simply close the file on that journey, switch off that 'computer' and 'go home'. We don't have to go back into that projected world with all its confusions of mind, have we?

If we are to take another chance to go back into a mind illusionary world, we may want to change a few things, of course, but is it wise to change anything? We must consider the vital option of getting out of that illusion again, at some stage at least, or we will be captured by that illusion of mind again with little chance of ever escaping. We sure don't want that, do we?

Back in our earlier mind illusive stage we may have wished for some options, which we could not manifest due to the programmed settings. We could now reprogram the settings from the operator's chair, but is that really what we want? In ways, even if not perfect and not fully in response to our own yearning, that existing set up got us to seek for a few clarifications that triggered us to find our way out of it all. Now in the 'operator's chair' we could change the settings, but is that really worth it? What is there to gain, if we really go back and loose ourselves for perhaps a few million solar years in a playful confusion of mind again?

We really need to think about that, when we succeeded, with perhaps great difficulty and a

portion of good luck, to get out of the world of mental confusion in the first place. Is it really worthwhile to go back, even with changed settings?

We see here that our world and universe, even if imperfect and not always to our liking, has been originally programmed to us seeking for solutions to our problems and to ask valid questions about our existence therein. If we were to change our personal circumstances by re-programming from the 'operator's chair' beyond mind, we may never be forced into asking those valid questions and loose ourselves in earthly play forever. So, it's good for us that such problems and shortcomings exist in our world. Would anyone ever want to leave an all perfect world?

### **III.5.3 Helping Others**

Okay, we have understood that changing our personal circumstances by re-programming from the 'operator's chair' beyond mind may not be the wisest thing to do. But what about helping other people?

Wishing to help others is a divine quality, but we have to realise that the position in the operator's chair beyond mind is our personal one and changes to our mind's programming don't affect the mind settings of others. Reprogramming ourselves will only be beneficial in a way that we stop acting like utter fools within the play, but it may not do any good to others. Being able to perform miracles and such sort of things, like healing the sick and raising the dead, has been done by others before. They often ended up in dire streets with such practice.

This world is not laid out to be healed by miracles. Whatever human society suffers in inconveniences is the direct outcome of its own actions. Suffering in such context is compensation to what was done before. Quite similar to medication that SUPPRESSES suffering, use of MIRACLE POWER to effect healing is unwise, too. Whatever ills have been created unwisely before, they need to be compensated for; that's the eternal law of the Universe: Wherever it started there it needs to end. Compensation of all action consequence is an inherent need for that. Willfully annihilating such compensation, whether by suppressive medication or by miracle power, doesn't serve its purpose. But wise counsel, given by saints and sages before, does help: One should carry the other's load; and forgiving each others' faults neutralises consequence, too. If we volunteer to share the suffering, we can help. If we volunteer to genuinely forgive, we can help. But we can't effectively help with suppressive type of action or with miracle powers of any sorts, as in such approach the 'problem' is not

resolved. Yes, we can HELP others, but not by reprogramming the play or forcing the issues. We can't reprogram the overall settings of the play; we can only reprogram ourselves.

### **III.5.4 Helping effectively**

To be able to help in this world effectively, we need to understand its basic settings and how things work. We will be able to understand that the easiest out of the 'operator's chair' beyond mind. For those who had not yet had the blessing to sit right at the controls of their own mind with full understanding of the settings of the world and universe a few guidelines will be given here.

We can see from Figure III.15 above that both mass and energy meet in mind. Effectively, mind is the mirror pane on which both mass and energy reflect. Beyond, it is mind that projects both mass and energy. In such context both mass and energy are illusions of mind that are being experienced 'as real' from the feedbacks of a five-sense equipped body. The feedback from the five senses give mind the illusion of the illusionary projection being real.

As mind is both projector as well as experiencer, the most effective way of healing is instructing mind. This can be done in three ways: By will power from the operator's chair beyond mind, by the use of 'mass' from within the illusionary projection and through the use of 'energy' from within the illusionary projection. The illusionary projection is that what we call our world and universe and in such context we are prisoners in such world and universe, though mind-illusionary, till we are able to get back into the operator's chair beyond mind and wake up from such illusion.

We have seen before that mind projects the illusion and through the five senses in the body gets a feedback of sorts that convinces mind, beyond all doubt, that such illusion is real. So mind is inside a self-created mental trap. But such trap can work to our benefit, if from within such illusionary world we direct mind by appropriate feedback that 'makes sense' to the mind.

All we have to do is to convince mind that our feedback is of real nature, just like the feedback from our five senses in the body convinces mind that things are real and not illusionary. The two tools for that are mass and energy, both being available plentiful in our world and universe, as our world and universe are mainly composed of those two. We just need to know how to effectively use mass and energy to effect healing through the mind.

### **III.5.5 Mental Healing using Mass and Energy**

Mind is a sensitive instrument that responds to gentle stimulation the most effectively. Such gentle stimulation is similar to sense stimulation from the body and as such the most convincing to an ever doubting mind. Brute force, in contrast, forces mind under one's will, but will never be convincing mind in a way that sense stimulation is working on the mind. Yes, mind yields under brute force, like citizens are likely to 'yield' under the pressure from a powerful tyrant, but most likely will counteract the moment such tyrant will show the slightest sign of weakness. The friendship between tyrant and citizens is rarely genuine and so is love for a tyrant. Ultimately, tyrant and citizens remain enemies, and so Self and Mind remain enemies, if we try by brute force to subdue mind. Yes, for millennia it has been taught that mind is our enemy and that we must subdue our mind to become masters. But the ones that have followed us till here with attention and understanding would have realised by now that MIND is an integral part of ourselves that is in a state of utter confusion. Mind is ill. Mind projects an illusionary world and the feedback from the five senses suggests to mind that such illusion is real. Of course, with such conflicting information mind must get confused. Under such circumstances the 'operator' beyond mind has 'lost its mind' and thinks of itself being stranded in a world of mass and energy, a world that feels all real to the operator through mind. The problem is in the mind and it is there where it needs to be resolved. So we got to work with mind and not fight with mind. Mind is the patient that lovingly and encouragingly needs to be guided to understand. Mind is only our enemy in the sense that mind is confused and habitually acts in confusing ways. It's up to us to bring mind back to correct understanding and out of habitual false information. How do we go about that using mass and energy?

We have learnt that all action, whether wisdom guided or confused-mind guided, is subject to dual consequence. We have understood that such dual consequence is due to the basic settings of this world and universe that 'where it started there it must end'. Such dual consequences are thus of a mutually compensating nature. What have we got to do now?

We could simply do nothing, like the sailors on a ship that travelled from London to New York and now hope that the waves and currents of the ocean somehow will bring such ship back to London without any effort from the side of its sailors. Yes, it could well be that over an undefined period of time such ship is pushed back by the ocean right back to London. The alternative would be the sailors taking concrete action to get the ship back to London in the shortest possible time. Taking the second approach, however, we must consider that all action

taken is of dual consequence; consequences meant to eventually annihilate each other. So we should take small action resulting in small consequence due to action, but in an effective end result. We must employ our mind in such equation: getting small action to influence mind to do the work for us. Remember, mind is the projector of this illusionary world and out of the projecting position capable of changing virtually anything by just projecting things differently. In such sense it is now mind that sits on the controls. If we guide and influence mind constructively from within our illusionary world of mass and energy, mind can be employed to 'rescue' us. It's just like using a 'Remote Control' while being away from the Operator's Seat.

Imagine an aircraft whose pilot has suffered a heart attack and the lives of 200 passengers are at stake. You, with virtually no flying experience other than a flight simulator in your computer at home, have taken the pilot's chair and someone from a tower of a distant airport is instructing you on how to fly and safely land the aircraft. That someone in the tower is you and the one in the pilot's chair is your mind. Remember, it should have been really you in the operator's/pilot chair, but in a 'switch' through mental confusion your mind is now sitting in the operator's/pilot chair and you are lost somewhere in a world of mass and energy. It is you who need to resurrect yourself into the operator's chair again and being capable to handle the controls of your own Self.

How will you gently and lovingly deal with your mind in such situation?

Just imagine the tower person belling at the one in the pilot's chair of the aircraft in military commanding ways. Such person may just walk away offended and let the aircraft crash. You can't afford doing that with your mind. You must find practical ways to instruct mind to operate the controls till you can do that again on your own.

What distinguishes the area close to the mirror pane in Figure III.15 from the area far from the mirror pane? We speak of mirror reflection, in which both reflections are opposite to each other. In fact, mirroring on  $0^\circ$  both  $+1$  and  $-1$  are opposite mirror reflections of each other. Close to Zero means also close to Infinite, doesn't it? So if we were to limit our conversation with mind to just such area, power used would be relatively small but close enough to the mirror pane, which is the effective communication tool of outgoing and incoming messages. Why? Because the mirror pane gives out illusionary dual projection and receives back real appearing feed back. Here we got to interact, gently, to modify the incoming message and affect a change in projection. If we use force at such point, mind will know it is being tricked and likely will filter our input out, conveniently. So be gentle, don't force the issue. Mind is confused, but mind is not stupid. We got to interact with mind, not force things down mind's

throat. That's imperative!

Using MASS we stay with our remedy in the region  $0 < +1$  and using ENERGY we stay with our application in the region  $-1 < 0$ . If we go outside such area, like for example  $> +1$ , we are leaving the effective area of gentle communication. We may have to 'scream' then at mind and mind may become sulky and non responsive. If we force the issue, our operator may respond under pressure, but conveniently change the other way around, when we are distracted for a moment. Under such circumstances mind is then our 'declared enemy' and not our 'confused friend'. We got to learn to work WITH MIND and not AGAINST MIND. Staying close to the mirror pane that interacts with the dual world of mass and energy by ways of projection and reception is the most effective way to drop our gentle feedback message in. Then mind will respond without rebellion. Mind is not our enemy. Mind is an integral part of ourselves; it is a friend that is temporary confused due to conflicting information, illusionary message out and real appearing message in. How can an illusionary projected world suddenly feel so real?

Are there any situations, when we may have to force the issue? Yes, there are; in so-called emergency situations. When life and welfare are at stake, we may have to temporary force the issue to keep mind on track. So, we see that things are relative here, too, and we need wisdom to know when force is necessary and when gentle infiltration of the returning messages through the sensory body apparatus is the more appropriate approach.

A third option exists in temporary switching of the five sense sensory apparatus of the body so that mind won't get any feedback at all. In such situation mind is literally switched off from all conflicting information and could find back to itself. It is confusion of mind caused by a conflict of projection and returning sensory information that is the problem. Switching the return messages simply off, mind will find back to itself through proper orientation. The outside world is mere illusionary projection and not, as the five bodily senses portray, a real world of its own.

How do we switch off the five senses of the body that deliver to the mind messages conflicting with what mind is sending out and thus causing confusion? Such practice of switching off the confusion causing return messages from the body-sensory apparatus is called MEDITATION.

We do now perhaps understand what is the actual purpose of meditation. It is not to see and experience something, but to come to clarity what is going on. Mind, no longer confused with the conflicting return messages, comes back to senses and can orientate correctly. In such sense, any form of focus on the sensory body, be it sound, sight, smell, taste or touch, does

not conform with meditation. In proper meditation, other than contemplation and outward concentration, mind must come to rest and find appropriate orientation. The conflicting and mind confusing messages from the five-sense body apparatus are to be switched off.

So, there are effectively three practical ways of mind healing:

- (1) by the use of mass
- (2) by the use of energy and
- (3) by switching off the five-sense feed back in a process called meditation

All three forms of mind healing are effective in their own way. Switching off the confusing messages from the five-sense body apparatus may be the most effective one, but only can be successfully employed, when mass and energy related problems are not standing in its way. We may, therefore, start with meditation and apply mass and energy means of healing as we go, when sensory messages such as physical pain and discomfort interfere.



### III.6.0 Implications

We are, in our essential nature, Gods that have come here in an entertaining game. But we are not born as Gods; we are born as ignorant human beings. That's the essence of the game. It is up to us to decide or not to decide, to choose or not to choose, whether we want to claim our inherent Godhead again. Those who opt to be so-called human beings, and the majority does, will spend a lifetime on Earth participating in ignorance. Those who opt to reclaim their inherent Godhead may have to struggle and work harder, but ultimately play and participate with wisdom based knowledge. Religion propagates BELIEF to the masses, which is none else than unproven facts and knowledge. Gods have proven facts and knowledge, but religion is not equipped to teach that.

Like a primary school is the foundation for a later university education, religion is a very practical foundation for later study and accomplishment of Godhead. Religion in itself is, as such, not useless. What is useless is that followers of religion, irrespective of which one, tend to get habitually and fanatically stuck in basic religious principles, belief systems, and all too often ritual. While those may be warming and fulfilling to heart and feelings, they do little more than giving an introduction to what is still to come. It's like being stuck in primary school forever and never endeavour to try high school and university. For the masses, perhaps, which dread change and growth, religion may be the ultimate solution. Yes, religion unfortunately is opium for the people, a drug with which they black out wisdom and understanding and follow a leader just like sheep. If their leader is blind and ignorant, so the followers will be. In such respect, religion could be a convenient means to keep people 'drugged' and ignorant of the facts and keep them playing in such frame of mind on the world stage: Not knowing what is going on, not knowing what is happening here.

Ignorance, unfortunately, is no excuse and no exemption to just 'punishment'. Everyone is held to investigate on one's own and the one that fails to do so will be 'judged' the same way as the one that investigated and put effort towards wisdom and knowledge. So better to be knowledgeable to avoid errors within play and participation than being ignorant and blundering around! But ultimately, it is everyone's own choice.

In our inherent nature we are Gods that descended to participate in a play. This play is devised to be played and us participating in fairness to all participants. We are all volunteers to such play. Our inequalities here on Earth are the direct result of our own choices made before coming here. Why would then anyone choose to be poor rather than rich, ill rather than healthy, in bad circumstances of life rather than good circumstances, and so on?

### III.6.1 Our own choice

We will only understand our own choice from the angle and perspective of us being all-knowledgeable Gods that came here to participate in a play, knowledgeable or ignorant of the 'facts of life and existence'. In such context we have learnt in the 'Book of Ultimate Wisdom' that the concepts of GOD and HUMAN are just mirror pictures of each other, a dual projection that originates out of a THIRD. That THIRD is MIND.

We are what we are in mind, first, and then mind projects what we endeavor to be. That sets the scene.

Mind projects our ideas and receives 'feedbacks' from the five senses of our body that makes things to appear real. If we only could switch off our five senses, like in deep meditation, inward concentration in lieu of outward concentration, we would quickly realise the non-reality of the world we live in. It is all in Mind.

In pure Mind we feel and understand correctly, but the five sense feedbacks from the body confuse. Unreal becomes real.

After physical death, the death of the body and not the death of us, the disturbing input from the bodily senses is switched off. We are back in Mind, beyond human existence; yes, even beyond 'God'-existence. It is in that state that we understand what has happened to us and that we may have participated in the Play as ignorant Fools or, per chance, as knowledgeable Gods. But the consequence to such participation remains the same. The participation in that Play was supposed to be based on fairness to all participants. In such fairness the entitlements to all players were the same. But if we, perhaps ignorantly, pushed someone away or mistreated someone unfairly, we have to answer for that to ourselves. Soul knows such rules. Having not participated fairly and within the set of rules, we got to make up. Soul will be dictating such rules and means of 'making up' as a projection through Mind. In another projection out of Mind the scene may then be set to participate in unfortunate circumstances, though, objectively speaking, everyone of the participants in the play deserves equal fairness. It is our own Mind set, before life and participation on Earth, that sets the scene of us being in fortunate or unfortunate circumstances here on Earth. Call it fate? No, there is no such thing as 'fate'. 'Fate' was created by ourselves and only us can change 'fate' by appropriate participation in the Play. We got to make up for our earlier shortcomings under the Rules of the Play. 'Hell' could be here on Earth, indeed.

Then, what we got to do? How will we know?

### **III.6.2 Communications with Mind**

'Mind' got us here and set the scene for our circumstances. There is no 'God' up there that rewards and punishes us. We are, ultimately, the God ourselves and as such reward and punish ourselves: Out of Soul through Mind. As such it is vital that everyone here on Earth learns to be an all-knowledgeable God in lieu of an ignorant human being. To be a God we need to adhere to divine principles. Those principles were given to us in our Holy Scriptures. Religion's duty is to acquaint us with such principles, in their very basics, so that we are enabled to move on to 'higher education' in the works of life and universal existence.

We said earlier that both concepts of God and Human are a dual projection out of Mind. Under such constellation we need to live Godhead to just 50% to be on track. We are not asked to be Gods 100%; just 50% God and 50% Human. That's not asked too much from anyone, isn't it? But under such context of equally being God and Human alike, we will have at least the requisite knowledge and wisdom to play fairly within the set rules of this play. Is that asking too much of anyone?

Religion fails, when it seeks to pamper the human beings by 'interpreting' holy scriptures selectively, be it out of fear of the daily food for its priests and clerics or just out of a whimsical approach to power and control or both. Then religion is clearly misguiding us. But otherwise, religion is our foundation, our pre-school and primary school, so to speak, to understand our basic existence and participation in this play.

There is no best and worst religion. Mind has projected us into a religion that is best for us under the circumstances. Mind has set our entire circumstances of life for our further participation. The emphasis here is on 'further participation' and not 'circumstances'. The circumstances are for the start; it is up to us to improve or worsen our circumstances within the Rules of the Play. Fairness to all is paramount in that.

As such, astrological forecasts may have a point, but such forecast relates to the start and not the final outcome. The final outcome rests with us. Difficulties we encounter may be still related to the basic settings projected by Mind and expounded by astrology, but it is up to us to change such unfavourable settings in our own approach to life. We are not hapless victims of some 'fate' and 'astrological forecast'. But to make up for flaws of the past we may have to

struggle much harder to the same ends than others who projected better circumstances out of their Minds before starting to participate again. Such projection was created out of earlier participation and as such is the result of our earlier actions. We alone are responsible for such. We need to learn to communicate with Mind, as Mind has projected our current circumstances. Mind effectively knows the 'why' and 'what for', but is getting confused from the endless stream of information from the bodily five senses which make things appear real. It is up to us to learn to switch off such confusing and often misleading currents by appropriate techniques such as meditation. When we communicate with Mind, Mind must be undisturbed. Or else, in confusion of Mind, we could get misguided again. Mind must be at rest and in the same peaceful state like Mind would be after physical death. Then Mind only knows what is going on; otherwise Mind won't. We don't have to physically die for that, but, yes, may have to invoke a state that is similar to physical death. Can we exist, even for a short while, in a state of physical death? Modern medicine will tell us 'no', but there are reports of people that can exist in death state and still are not dead. We need to learn to be 'dead' without dying. We sleep daily, but we are not afraid of it. In sleep we are unconscious of ourselves. Still, we do it daily and aren't afraid. We just need to learn to 'sleep consciously', creating a state in which the body sleeps and Mind is awake. Then communications with Mind will be effective. The trick is to switch off the five senses with its confusing information. Then Mind will be in a state of clarity in which Mind can communicate with us. We got to know what we got to do and why we came here to Earth in the first place. Otherwise we'll be just wasting our time here.

Mind is not our enemy, but our friend. Mind only becomes our enemy, temporary, when in confusion it sets out to misguide us. Mind is bound to habit. So before we enjoy ourselves here on Earth all habitual mental patterns must be overcome by self control. That may be a bit painful in the beginning. But when self control becomes sort of a habit to us, then self control will be much easier to practise. We need to get Mind free from habitual settings. Then we have to put Mind to rest and out of confusion by switching off the five sense currents. Not confused and not habitually inclined our Mind will be our friend instead of our enemy. Then we can work with Mind reliably. We got to know, so we can act constructively. How can we act constructively, when we don't even know?

Self-Realisation is twofold. For once, we have to be able to understand out of our own self and not repeat, like parrots, what others have told us. That's what high schools and universities should strive to give us: clear thinking out of our own self. Learning by heart and memorisation of details that are repeated, parrot like, in exams are futile. We got to develop our own thinking process to give us self-realisation instead of parrot like repetition. That is also what religion should teach us after acquainting us with the basics.

After self-realisation comes application. If we don't know what we ought to do, how can we do it? Knowing, not believing or parrot like repeating, is the first clue. Knowledge can only come out of our own self in a process of self realisation. Then, and only then, when out of our own self realisation we know what we got to do, we can and must proceed with application. Please remember, in such respect, that everyone is still bound by the inherent Rules of the overall Play. So don't set out to self-realise by trashing all the Rules. You got to play by the Rules, no matter what you do. But that doesn't mean that you can't break the rules of country and society, if you must do and are willing to suffer the consequences. But don't break the underlying Universal Rules of the Play. The rules of country and society may not always be in line with the Universal Rules of the Play. The Universal Rules of the Play are paramount and go before rules of country, society and family, which are often habitual and customary. You need wisdom to decide your approach. So acquire divine wisdom, too. You could, for such, study the Holy Scriptures yourself and refrain from relying on interpretations from others. You got to know; this and only this is **Self-Realisation**.

This Book of Ultimate Wisdom can only give you the basic approach patterns. The hard work of Self-Realisation Part 1 (knowledge and understanding out of your own self) and Self-Realisation Part 2 (diligent application of what you ought to do out of that earlier attained Self-Realisation Part 1) is your own. We can't give you that; no one can. You got to struggle for that on your own and if someone claims that he/she can give you self-realisation, then such person is clearly misguiding you and perhaps just out to get another blind believer in the flock. Guidance on how to find self-realisation can be given, of course, but self-realisation, as the word says, is your own. But beware of teachers that manipulate your thinking, step by step, in such ways that your own self-realisation is a manipulated one, because you have no room and freedom left to come to any other self-realisation than the one you have previously been brainwashed into. Your self-realisation got to be free and wholly your own; otherwise you'll be, effectively, just another parrot that repeats the statements of others in a frame of manipulated self-realisation. You are free to doubt all the guidance given in this Book of Ultimate Wisdom, but be fair and investigate yourself, before you rip this Book into many small pieces. Your own investigation, if honest and not profit oriented research, will show you the way. Unfortunately, these days of the so-called modern 21st century of the Christian calendar, so-called experts and specialists are being paid by interest groups to do questionable research studies with pre-programmed results. Such results confirm the goals and aims of such interest groups. Nothing could be more incorrect and misleading. So beware and do your own non-sponsorship honest approach; don't rely too much on what others say. You got to find your own results and for that you got to do your own study and research. There is, unfortunately, no other way to that.

### III.7.1 Who am I ?

That is the essential question, 'Who am I?' and the essential answer is 'Whosoever I think I am', as Mind is the projector. It is about positioning; positioning oneself at different angles or perspectives of consideration.

If I think that I am a human being, then I am a human being, and if I think that I am a God, I am a God. But there is still a restriction to that. If I think to be something, I must also be able to feel, understand and act out of that perspective. It is easy to say 'I am a God', when effectively I feel, understand and act like a human being. Then I am a God only in my imagination and not in actuality. Right thought must be followed by corresponding feeling, understanding and action.

Where do you wish to position yourself? There is a dual reflection out of a projection that is directed through Mind. So there are four options of positioning. You could be a human being, a divine being, the projector Mind and the one that directs the projection, i.e. directs Mind.

If you are in the 4th position or perspective of being the operator of Mind, you're really in control. That's Soul! Mind then projects into being whatever you, Soul, tell Mind to project. You could grow yourself a new set of teeth every ten years or so and make changes to your body too. It is Mind that creates your body through projection, a dual entity composed of mass and energy. But, if you opt to be the operator of Mind, you also must be able to control Mind and not be the one who is controlled by Mind. You must actually be, what you claim to be, and not just say that you are that. You must be that!

Okay, you've been habitually a human being for say forty years. Such habit, after forty years, is likely a strong one. You will have typical human thoughts and perceptions. You will need to snap out of that and train yourself in divine thought, feeling, understanding and action. Such divine thought, feeling, understanding and action may be reverse to their human counterparts, as human and divine are dual projections, mirror images of each other. Becoming a divine being your habitual human world is likely to be turned upside down. Are you up for such challenge or you'd rather stay a human being following your forty years of habitual perception?

A big challenge ahead, indeed, and your mind, your feelings and self-understanding may rebel severely. What is wonderful out of the perception of a typical human being is dreadful to a God and vice versa. How you're going to deal with such reversal of your human nature?

You see by just some illustrations what is ahead of you. Saying to be a God doesn't make you a God. You rather must be a God in body, mind and consciousness and not just in your thoughts. You must live divinity, express divinity, think and understand divinity. That's the first challenge you must master on the road to become the Master of your Destiny, the one that controls and directs through Mind.

Luckily, due to dual projection, it will be sufficient to learn to be Divine to just 50%. But these 50% must be genuine and not just half-hearted 49%. You must be as Divine as you are Human; in equal proportions. That will set you free to topple duality imagination and slip into Mind, the projector. Now you can perceive the entire world out of Mind perspective and will understand how things work and how things came into being. But to take control, you must slip beyond Mind and take control; in a similar way as a rider climbs a horse and takes control of the horse. You and Mind must be in harmony, otherwise Mind won't follow. You will only be in harmony with Mind, when you made close relations of a loving kind, when you still were in the Mind perspective. Mind must be your friend, not your enemy. Otherwise Mind will bring up strong force to resist you. You must be in charge, but without abusing Mind. And before you can be in charge you must have learned the divine principles and been able to apply and practise them in daily life. One step leads to the other. You can't go ahead when skipping steps. You must master one step after the other.

'Who am I'? Meet the challenge and find out.

### **III.7.2 Enlightenment**

What is that, ENLIGHTENMENT? You must KNOW in body, mind and consciousness what is going on, where you came from, why you are here on Earth and what you wanted to accomplish. Belief will not help you here; you must clearly KNOW. The clue is Self-Realisation. You must self-realise what is going on, where you came from, why you are here on Earth and what you wanted to accomplish here. Religion and blind belief systems won't help you here; you must SELF-REALISE to have KNOWLEDGE; facts and not just some belief or philosophy. You must be knowledgeable out of your own Self.

In the Enlightenment Process you'll feel like someone is removing a dark shroud from your eyes and suddenly you understand, in all clarity of mind, and perhaps wonder why you couldn't see things that clear before. It is all so simple and logical; but somehow you were not adapt to see things in such clarity. You'll feel as if you have been blind before and now you

can see in all clarity. That feeling you'll have then is what is called Enlightenment. It's not a physical light that is involved, but rather an inner clarity becomes yours that you may never have experienced before. But, Enlightenment is only the first step. After Enlightenment comes APPLICATION.

One may wonder what is more difficult to attain, Enlightenment or Application. Enlightenment is not attained easily, and Application after Enlightenment may even be more difficult than getting Enlightenment in the first place.

A student may have studied MEDICINE at the university and finally, after many years of diligent study, learning and certainly struggle have received the Certificate that he/she is now a doctor. What comes next? Next comes application, putting to practice what he/she has learned and in such process getting experience. Similarly for Enlightenment.

So there are three steps to master:

- (1) Enlightenment
- (2) Application
- (3) Experience

Experience will qualify the adept to approach issues with authority. A believer has no such authority; a believer follows pre-set teachings of someone else, perhaps sheep-like. The one with true Authority based on Enlightenment, Application and Experience is strong and able to dispel myths and superstitions. He/she KNOWS what he/she is doing and can explain it. There are no myths around it.

Knowing oneself doesn't mean that others know or that one is able to explain things to others so that they will understand. Why? It's because everyone will have to master one's own self-realisation process resulting in Enlightenment. One can help others with the initial steps towards that, but not more. If others are unwilling or simply too lazy to make the necessary efforts, all such help is futile. At its best one might just start then a new belief concept or religion, where people follow a pre-set belief system, which they have not understood out of themselves.

We would ask every student of this Book of Ultimate Wisdom to NOT turn this Book into another Holy Book that is worshipped by the masses. We do not propagate religion or belief concepts. We advise on practical steps on how each one of you could become a Buddha, Christ, Krishna, Prophet, Rama etc oneself. These are merely titles of achievement and not relevant to certain persons, even though they have been used as such. Yes, there was once a



Gautama Buddha and a Jesus Christ. The first word was the person's name, the second word the title. The title is not reserved to the one and only person to whom it was given to. You could add the title Buddha, Christ, Krishna, Prophet, Rama etc to your own name, once you have truly mastered that state. Please refrain from misguiding others by using such titles without you having achieved such state of wisdom; it's as inappropriate as you claiming to have a doctoreate from the university, when you have just tried, but never finished the course. You must be accomplished on all three levels, the enlightenment, the application and the experience part, that allows you to speak with authority about the subject, before you can say that you really have mastered a doctoreate. Many the doctoreates these days aren't really up to such challenge yet, though the university may have given them the coveted title. The title alone, as such, doesn't say much about the actual person.

### **III.7.3 Up to the Challenge?**

Are you up to the Challenge? Which challenge? The challenge to develop yourself into your inherent Godhead and in such process leave everything behind that stands in its way? A saint, who once bestowed the blessing of an advanced technique on his disciple, simply said: Give this Kriya (rite) only to eligible students; those who are willing to give up for God everything else.

Yes, that is what it ultimately means; if you want to establish yourself in your inherent Godhead, you may have to give up everything else and, if you are not yet ready to give up everything else at this stage, at least WILLING to give up everything else, when the time comes to do so. Without such honest WILLINGNESS you can't succeed. Being a God is different from being a Human, and both are ultimately projections out of Mind and the Power behind Mind that is actually YOU; or more correctly speaking, should be YOU, as currently you are still projection of mind, whether Human or already a God. If you wish to be your real Self, the power beyond mind that projects this world, you'll have to leave all human and divine concepts behind, as both are mere mental projections. Are you up to such challenge?

Then WHY did that saint say that you got to give up all else for God? It depends on the definition of God. For human beings their mirror reflection is God, as some Holy Scripture proclaims that Man is made in the Image of God. But that God is none else than the dual projection partner to the idea of a human being. Yes, to claim that mirror projection partner, one will have to leave one's human perceptions behind, as in a mirror reflection things are oppsite to the original in front of the mirror. Divinity, as such, is Humanity upside down.

The one that eagerly clings to human concepts and perceptions can't embrace divinity. Things are relative here and no longer absolute. 'You shall not lie', one of the many scriptural injunctions read. Does that also apply when your well-nourished wife asks you whether she looks fat? Things are relative here and not absolute; same for all other scriptural injunctions. Wisdom is needed to understand when to use the one and when to use the other approach. That is what distinguishes Divinity from Humanity. PHYSICAL GOLD is the treasure of Humanity, GOLDEN WISDOM the treasure for the Gods. The legendary Philosopher's Stone, as such, was devised for the Gods and not for the Human Beings. You'll need to be accomplished in 50% Divinity before you can claim the higher mental aspects. If you, habitually, cling to established human practices in their absolute forms, you'll be unable to establish in Divinity. Why? Because in Divinity concepts and practices may be reverse to their human counterparts. Why? That's because Divine and Human are Mirror Pictures of each other. Beyond that, both are just dual projections out of a Third. That THIRD is what you need to climb upon. The Philosopher's Stone delivers the clue: Learn to be 50% God and 50% Human RELATIVE and leave your coveted human absolute ways behind. Things are RELATIVE and not ABSOLUTE. You need to develop in divine wisdom to be able to differentiate. A blind believer following pre-set belief concepts, blindly and absolute, perhaps even as a fanatic, can't do that. You got to be free from all fanaticism and clinging to absolute concepts. You got to have the wisdom of the Gods to apply yourself diligently in your daily life here on Earth. Once you are accomplished in such feat of being 50% God along with 50% Human the secret door to the THIRD will open up to you automatically. Before that, such door will remain tightly closed to you; you may not even know that it exists. The God is right within you, just behind your current Self-Perception commonly called EGO. As your EGO diminishes and gets smaller the God in you becomes more visible. Yes, pride comes before the fall and humility comes before the rise. Remember that; the moment pride of Self enters your consciousness, the God in you withdraws. You need to bring the God in you out as an EQUAL partner to yourself, as both, the present Self you perceive and the God in you are equal partners that constitute the ACTUAL YOU. Beyond, in the THIRD, even that ACTUAL YOU, is imagination of mind. Develop, as such, the ACTUAL YOU, but don't get stuck there, as even that ACTUAL YOU isn't really YOU. You need to develop yourself into that ACTUAL YOU, half human and half divine, equal partners of the opposite kind, and once accomplished the door to the BEYOND will open. Proceeding then into the BEYOND the ACTUAL YOU will have to stay behind. You got to climb beyond into the seat of the operator behind or beyond Mind, the one that is in charge of the entire project and who controls Mind and conveniently uses Mind to project the ACTUAL YOU in a dual imaginary world that only feels real, because the five senses from your body make things feel real in realistic feedback to your Mind. It's at such point that Mind and ultimately the Operator beyond Mind get confused. Human existence, as such, is none else than confusion of Mind.

### III.7.4 Beyond Mind

Beyond Mind, that's the seat of the actual Operator. That Operator could be YOU, if you are willing 'to leave everything behind for God'. Your current state as a Human Being is nothing else than a state of Mental Confusion. You are not a human being; you are not even a God. Both perceptions are illusionary dual projections out of Operator Consciousness through Mind. The confusion arises when the five senses of the human body reflect sensation back to the Mind. In Mind such feed-back is experienced as real. The Operator gets confused: Am I now a human being or not. The feedback is real, when the projection was illusionary. Human existence has become a reality to the Mind. The Operator behind Mind now gets convinced to be Human and believes in such illusion. In confusion of Mind the Operator is Human. It's up to you to backtrack and snap out of it again. The strategic approach in doing so has been given to you. What is left is your own will and action to actually do it. The entire problem is psychological and not physical. You got to come to terms with your own psychology.

The Operator also could be called 'Soul'. SOUL has a MIND, but isn't Mind. It is for SOUL to get its own psychology right and snap out of the illusion of human existence. Even divine existence, in such context, is illusion of mind. In such dual projection out of Mind you are human and divine EQUALLY. Unfortunately, you have only developed the human aspect so far. You got to develop your inherent divine aspect EQUALLY.

The challenge, before the human and divine aspects of equal development, is gender. Your body may be male or female, as the case may be, but the Soul, the actual operator beyond Mind, is not. Soul is Gender-Neutral. If, due to a male body, you've focused on male side development so far, you got to develop the female part in you. If, due to female body, you've focused on female side development so far, you got to develop the male part in you. You need to be able to portray the soul gender neutral state of being 50% male and 50% female in perception and consciousness before you can tackle the Divine-Human aspect in its final way. Before managing the gender aspect of Operator Soul, there are a few other typical human issues to address, such as fictional aspects of nationality, culture, class/caste/race and religion. They are attributes of illusionary human existence and you got to snap out of that, if you want to be Operator Soul (beyond and behind Mind) again. One step leads to the other. Life is short and there is much to accomplish on your journey 'home'. Start now and don't postpone. Once you die your body is dead, but you are not. You'll embark on another journey and so on. But with each start you have to remember again and proceed correctly or you loose yourself, once again, in illusionary traits due to the many attractions and distractions of the illusionary physical world in which you are, illusionary, a human being.

### III.7.5 Obstacles

You've been bom, in just another round, once again into the world of human illusion and protrait, in characteristics, a nationality, culture, class/caste/race, religion and gender. Whatever your characteristics, you are again a typical human being like so many others, who in a process of so-called upbringing are literally brainwashed into believing that they are what they portray and that those characteristics are inherent to them.

When will you wake up and realise that all these things are just superimposed on your real Self. You are not what you think you are, except in your own imagination and the perception of the people in the world around you. When will you snap out of it? The sand clock of life is running and the longer you wait, the less the chance that you'll make it this time round before physical death catches up with you.

Your family's perceptions and their wishes for you and your career may be obstacles to your journey out of the dream state of human existence and beyond into the Soul Operator Control Seat. Your friends may not be on your line, too. While the Holy Scripture generally proclaim that you should treasure your parents and elders, your teachers and peers, those who are engaging themselves in your favor, and so on, please remember that these injunctions of the Holy Scriptures are meant as a guideline and are to be taken RELATIVE and not absolute. You need to develop WISDOM to differentiate.

DISCRETION is the first you'll need to develop and practise. As you move slowly away from the pre-ordained perceptions of your family, peers, and elders, you certainly will not be in their 'good books' with them. Discretion, i.e. not telling or portraying to others what you are doing or up to, isn't dishonesty in such context. Remember in such context that lying is relative, not absolute. You're not outright lying to anyone by being discrete; you're not discrete with the intention to harm or hurt anyone. You are discrete in the intention of self-development beyond the pre-conceived human perceptions. You can't explain yourself to anyone, as likely no one will understand, but rather criticise and try to pull you back to what the majority perceives to be right. Use discretion to self-develop yourself beyond the pre-conceived ideas of your society. That includes not sharing or communicating your views with others of opposite opinion. Before you do that you must be an authority yourself. Remember, to be an authority, you must have past the stages of Enlightenment, Application and Experience yourself. Belief and Assumption will not help you here.

### III.7.6 In Daily Life

What to do in daily life? Remember, there is a God in you, your EQUAL partner within yourself, someone you may have neglected so far, as you didn't know of its existence. That inner partner, the God in you, is as much entitled to participation in your daily affairs as you are yourself. Unfortunately, EGO is huge, the I, MY, ME, MINE is everything and eclipsing the God inside wholly and totally. You got to do, initially, two things: (1) Reduce your EGO and learn humility, and (2) involve the God in you in all your daily affairs and ventures.

So, when you eat, who is eating? Yes, I am eating, correct, but the God inside you, your equal Self and partner, is eating, too. How do you go about it in a harmonious and fair partnership? YES, you involve your partner. How will you do that with your partner within you? Just tell him that what you like to eat and do and dictate your terms down his throat? Certainly not!

You got to involve your inner partner in all affairs. That's from the planning and decision making onwards. Communicate with your partner. There is no input or reply from your partner? No wonder, you have ignored your partner for too many years. Remember, your partner within is your mirror picture; you are made in its image. So, if you are male, your inner partner is female. If you developed only the male aspect of yours, your inner partner yearns to express the female one. And if you are female, your inner partner is male. If you developed only the female part of yours all these years, your inner partner is yearning to express the male aspects. Being focused to the outside world, your inner partner's yearning may attract someone of the opposite gender into your life. That's because you tried to close the gap within your inherently NEUTRAL Soul Nature with an OUTSIDE partner.

Apologies to the homosexuals, gay and lesbians in such context. Our world is, inherently, opposite dual in nature and opposites attract, whether on the inside or the outside. Homosexuality, gay and lesbian feelings and urgings are of a different root; they are not of a dual world and perception kind, but mental desperation that seeks to express. Such mental desperation of expression was created either in an earlier incarnation when lust had taken the place of love in one's consciousness or in the present incarnation due to circumstance. Such circumstances include being deprived of an opposite gender partner, like in monasteries, military or prisons. Male and female are superimposed on one's consciousness, generally pertaining to the physical body, whereas the Soul is gender-neutral. Out of Soul perspective, the Soul therefore would only express gender-dual at equal terms, similarly as the Soul would express human-divine-dual at equal terms. In confusion of Mind the Soul expresses one sided, usually as the body portrays. In reincarnation, the gender frequently alternates, as one sided

expression male OR female creates a gender-vacuum in soul consciousness. In order to fill that gender-vacuum the Soul changes physical appearance generally alternating from one incarnation to the next. If LUST reigns the consciousness of some person, that LUST then impregnates the Mind with a fixed thought that might be carried forward to the next incarnation as a seed tendency. Was it a MAN, who WITH LUST engaged in sex with WOMEN, the Mind is impregnated accordingly after the physical gender has changed to FEMALE in the next incarnation: Now it is lust in terms of 'woman to woman'. Was it a WOMAN that WITH LUST engaged in sex with MEN, the Mind is impregnated accordingly, after the physical gender has changed to MALE in the following incarnation: Now it is lust in terms of 'man to man'. Please note that such homosexual settings, gay and lesbian, are **not** punishments, but **natural consequences** of strong mind settings of an earlier incarnation. It is for such reason that Holy Scriptures warn of lust as an evil. The resulting mind settings mix up things in future incarnations and prevent individuals from expressing the natural dual settings due to very strong one sided focus. The remedy: Discover the dual partner within yourself and set the record straight; remove lust from your consciousness and change it to love. This is a vivid example of how a strongly thought and habit impregnated mind sets the stage for the next incarnation.

Another vivid example is transgenderism. Here we distinguish two forms, the inherent homosexual transgender and the inherent heterosexual transgender. The roots of inherent homosexuality have been explained above and such person could miss, additionally, the body of the last incarnation; the man that wants to be the lustful woman he was in the last incarnation or the woman that wants to be the lustful man of the last incarnation. In both cases 'previous lust', if not present circumstance and fantasy, is the driver in the mind.

But, there are also those that have advanced in self realisation in an earlier incarnation, sort of established themselves in mind close to neutral soul-level, and now, in the new incarnation seek the dual gender partner within, when the body is laid out single gender and the upbringing and exposure in the world is in accordance also single gender. The mental vacuum caused by such one sided upbringing causes the neglected gender of the neutral soul to rebel in mind. Then we have the humanly little understood situation that a heterosexual man wants to be a woman and a heterosexual woman wants to be a man. Here the mental vacuum caused by one sided gender upbringing is the driver. The remedy for both would be embracing dual-gendership, as that is the inherent gender and nature of the soul, when it projects itself in soul-self awareness into a human body. In soul nature we are inherently gender-neutral and in projection we would be then inherently dual-gender; perhaps even being born into a so-called hermaphrodite dual-gender physical body. It's confusion of mind that makes us perceive ourselves as single gender male or female. We are souls, inherently, not humans!

### **III.7.7 Involve your Partner**

That rule of 'involving your partner' applies to both the outer and the inner world. Whether your partner is outer or inner, you got to involve that partner in your daily life. It is, generally, difficult to develop a deep inner partner relationship, when one is in an outside partner engagement. The outside partner may then act as a distraction. The Holy Scripture speaks of 'Gods before the Lord' in such (and other) context. The one who focuses too much to the outside will fail to engage in a rewarding inner partner relationship. But portraying woman as a snake that distracts man from his divine path is equally incorrect. It is upbringing in various earthly societies that has pushed woman into a sexual role model that distracts man. This is earthly training received and not natural setting. Woman, in her inherent nature, is wholly equal to man. When woman is brainwashed to employ means like sexy dance (for the eyes), sweet talk (for the ears), perfumes and lotions (for the nose), soft skin (for the touch), and as a cook to prepare tasty dishes (for the taste), then this is a matter of upbringing and training, but not a natural setting.

RESPECT and CONSIDERATION for each other are vital, both on the inner as the outer plane. One can have a vital love relationship with the inner partner, when the outer one is of a natural and not merely sexual nature. The outer relationship must not become a 'God before the Lord' relationship. 'God' must always have the first place in one's heart; that's the vital clue. In the human world, unfortunately, women often claim to be the men's goddesses, so called Gods before the Lord. The first place in one's heart must be reserved for the 'God within'; that applies to both partners in a relationship. The goal in such ideal outer partnership is then to AID EACH OTHER in the development of the inner partner pairing, the outer with the inner, on both gender and human-divine planes. Then an outer partner relationship can be fruitful; otherwise it won't and only might serve to drag both partners down to mundane and mere social levels.

Involve your partner, constructively, and you shall prosper. Ignore your partner and you'll be on your own. Those who do not invite 'God' into their lives in good times will hardly find 'God' by their side in bad times. There is little point of running to temples, churches and mosques in times of crisis, when one has not also done so in times of happiness. Whosoever ignored the 'God' in good times has little to expect from one's prayers in bad times. That's simply 'Rules of the Game'. While outside partners may be bribable, the inner partner can't be coaxed out by anything else than genuine love. Invite the inner partner for participation in the smallest and most mundane affairs. It is the inner partner's right to be involved, as the inner

partner is an inherent part of the Self. It is the dual image of a Self projected out of a Third. If equal partnership of both images is not attained, the Third remains out of reach. In such context the inner relationship is more important than the outer one, but the outer one can be of help in developing the inner one, if the outer partner is an aide and not a 'God before the Lord'.

May please everyone take note of such settings. Those who wish to rebel may do so, but those who wish to develop beyond the human plane should not be distracted by such rebellion and objection. Yes, it sometimes is necessary for an eager spiritual adept to 'leave father and mother, even spouse and child', if such people purposeful put stumbling blocks in one's way. There is no absolute need for giving up on family life; but it may be necessary, relative to one's own personal situation. No father, mother, spouse or child has a legitimate divine right to hold back a loved one for selfish reasons. We all are projections out of a higher kind, all illusionary in nature, and the 'final reckoning' is beyond all projections. Retracing our footsteps back to Soul Nature and further beyond is our first and foremost duty here on Earth, beyond all else. No so-called 'loved one' has the right to hinder anyone in such pursuit, no matter what the reason!

### **III.7.8 Taking Rest**

It is interesting to see, how many intelligent people of this so called modern early 21st century of the Christian Calendar are literally working themselves to death, when even the processes of Nature take rest at times. Rest is inherently prescribed by Nature, which generally incorporates a 25% rest phase into a 100% cycle. Why then are we humans so greedy that we don't want to grant us any rest and keep on working non stop? Whatever we gain materially that way, we can't take that with us upon physical death. We sort of know that and still keep working on and on. Could it perhaps be that in addition to our 'real needs' we are being offered so many things, which we just 'want', that our life's expenses become so high that we allow power brokers to virtually 'enslave' us in debt to a point that we have no other choice than working ourselves to death? Those power brokers may ultimately be those, who use politicians, banks and industry to keep us stupid and not self-realise ourselves as Gods. Ideally, the week should have eight weekdays with two rest days to go by the 25/100% pattern. We all ask the perhaps valid question, WHEN do we have the time to conduct our inner research towards higher self realisation. That's what the two weekly rest days are meant for. But, if we recklessly don't give ourselves any break in our mad rush for material gain, then of course we won't emancipate ourselves in higher self-realisation. Then we die as



ignorant fools; likely as ignorant as we entered this world. Wasted life, wasted opportunities, one could say. So, please make time to conduct your own research. That research is as important as you making money for yourself and your loved ones. By the way, in close communications with your inner dual partner, the God in you psychologically, you might discover many valid shortcuts to taking care of even your physical needs. Just give it a try!

### **III.7.9 What is in it for 'Me'?**

Who is me? Is it the human being that is 'me'? Or the divine being that is 'me'? Or is it the third that is 'me' or even the fourth, the controller of mind, also called 'Soul'?

There is nothing in it for me, as there is no such thing as 'me'. Even Soul is just a projection out of a further one. Like the sun can be portrayed to emit many rays of light, Soul is nothing else than a ray out of something else. All souls in totality have created this world and play and are now interacting at various levels of Self-Perception. The source is further beyond, though. We will not be going into that in detail. Know just that you are a projection out of something that could be compared with rays being projected out of the sun or some other source of light. That doesn't mean, though, that the origin is the sun or some other source of light. It's just said for illustration's purpose. Light is inherently energy and belongs to the physical world composed of mass and energy. We are talking about the roots beyond mind and control of mind, beyond soul and rays of individual souls out of something else. Such thought surpasses human understanding and we'll refrain from spinning back our thoughts any further. You'll have to experience for yourself, you'll have to find out for yourself. Yes, there is nothing in it for yourself, as you, in all self-perceptions are just imaginary in all kinds. Who and what you are, ultimately, you've got to find out yourself. We can give you the starting ideas and strategies in this Book of Ultimate Wisdom, but the consequences and finals you'll have to self-realise yourself. No one can do that for you; it's your own path of enlightenment, application and experience that will lead you to that.

### **III.7.10 The Ultimate God**

Much discussion, even dispute, is there among human beings 'Who is the only true God?'. Any God that can be differentiated against other Gods, be it by name or any quality, even the term 'supreme' or 'ultimate', is still a God of Relativity, as such God can be compared with others.

We need to reach beyond and in that beyond, where there is no comparison or differentiation left, we may find, eventually, our ultimate True Self. We are that, all of us, in totality and beyond any differentiation of individuality. All else is just projection and dream. It is up to us how far we wish to climb into the 'Beyond'. For some persons the idea of losing 'individuality' may be a scary one; one can hold off at such level and remain an individual at perhaps soul level; the controller of one's life and destiny beyond Mind at Soul Self Level. We are all Volunteers to this Play and can position ourselves mentally and psychologically at whichever level we wish to. But we must also learn to express ourselves at such level in tune with the inherent settings, as a God in-lieu of a human being or as the controller of Mind at Soul Level or even further beyond beyond all projection of individuality. It's all our free choice as we are all volunteers. We are that and to be that we must be able to portray and express that. If we are Gods, we must be Gods, and if we are Controllers of Mind, we must be that too. Just saying doesn't make us that; we must live and practise what we say we are.

We are all born under certain circumstances here on Earth. Call it destiny? There is no such thing as destiny. We have created those circumstances ourselves sometime before. In such sense we are the controllers of our own destiny.

Whatever we are now, that is the start to build on. A rocket that is to fly into space needs a solid ramp to start from. Whatever we were given by birth and circumstance is that ramp; we just have to solidify that for a good start and lift off. Whatever religion, gender, class/caste/race, cultural setting or nationality you were given, please don't cast that off. Rather add what was not given to you, as you were not yet accomplished enough to receive it by circumstance. If you yearn to be female while in a male body, by all means, don't remove your male gender characteristics in surgically acquiring the female ones; analog for women that seek to be men. Don't give up what you have already, but just acquire what you don't have, if Mind yearns for that. You are supposed to be EVERYTHING and not just SOMETHING; so make sure that in further self-development you become EVERYTHING and not just SOMETHING ELSE.

Nothing and Everything are one and the same, as it is in Zero-Infinite 0° where the circle starts and closes. That is the vital clue that is to be kept in mind. Be NOTHING in your own Self-Perception and where Self-Development is the issue, strive to be EVERYTHING or NOTHING, but not SOMETHING.

Have no Gods before the Lord and make the God the first issue in your life; more important than anyone and anything else!

### III.8.0 To Be or Not To Be

That is here the question. Becoming a God isn't easy and being a God may be even more difficult than becoming a God. Why? It's because we are still here on Earth in a human or human-like body and others may mistake us for humans like themselves. Or, if we had made physical changes, like becoming dual-gender physically in a process of being 'Everything' rather than just 'Something' or 'Something Else', we may be simply stamped as 'unwelcome outsiders'. In a world, where human beings are in the vast majority, Gods may not be welcome or understood.

Gods and being a God is subject to certain rules and conditions. Being a God is, by qualification, based on HUMILITY. We can't just go out and prove our 'being a God' by things like miracles, even if such miracles are in the interest of suffering man- and human kind. We are not to portray ourselves among human beings as having outstanding powers that human beings have not. Doing so automatically disqualifies one from being a God. Humility must be utmost at all time. All sorts of pride and show off come before the fall and yes, becoming proud to be a God and showing off in any way could be the cause of one's own downfall back to a human level. Divinity is not characterised by special powers, but by the humility to resist such attractive means of self-expression.

Our readers may wish to point out, in such context, great saints like Jesus Christ, proclaimed by some as the Son of God, who has proven his case through many miracles like healing the sick and raising the dead. Such powers alone didn't make him the Son of God, even though religion wants us to believe that. Even great saints sometimes make mistakes in their own eagerness and may then get 'punished' for that. The 'punishment' of Jesus Christ was then crucifixion; not death on the cross, but a convenient, though painful, means to get away from the masses attracted to him by his miracle powers; by making people believe that he was dead.

The one that reads the St. John Gospel in the Christian Bible with an open mind and guidance from one's inner divine Self will realise that the entire crucifixion was nothing else than a clever pre planned set up, though with some surprising not pre planned additions, which covered up for oversights of the planner itself. Jesus Christ was crucified, suffered, but didn't die on the Cross.

Jesus himself had realised that his mission to teach the people had failed, as he tried to prove himself to them by miracle powers and thus attracted the people to himself, Jesus, instead of to God. The end of his mission resulted in personality worship of an external person, Jesus,

rather than Christ/Buddha/Krishna/Rama etc, the God within everyone. We are all sons and daughters of God, not just Jesus Christ. We just have not learned yet to express such divinity from within, though such nature is inherent to us and everyone.

We may understand now that approaching a confused world by proving oneself as an enlightened God by means of miraculous powers is not the appropriate approach. With such approach one attracts the masses to oneself and not to God. One also makes oneself, quite likely, a lot of enemies, too, as earthly power brokers may wish to employ such 'God' to their own selfish ends. Refusing such requests may turn then such power brokers into dangerous enemies. Last not least, interfering with established law and order by employing miraculous powers to attend to the sick and dying must invite the hatred of those that lose their jobs and earnings: doctors and pharmaceutical companies these days.

Let us all learn from the mistakes of Jesus Christ and let's try not to repeat them. He was a great saint and master after all; but everyone here on Earth can make mistakes. It is important to learn from our mistakes and simply move forward from there. That's the way that any student eventually turns into a master, even a self-realised God. And so did Jesus Christ, eventually.

For Millennia people have lived with the false belief of having to search the God on the outside, when in reality that God is right within everyone. It is the aim to develop such relationship and bring that God out of oneself. Worshipping any external statues and external rituals are of little value then. They rather distract from the true purpose than aid in its development. It is for that reason that Holy Scriptures of all kind point out that it is unwise to worship deities and lesser Gods. Such worship then leads to confusion and focuses on outer Gods, when the true God to be worshipped is right within oneself; right behind what is termed nowadays as EGO, which blocks out vision and perception like an inflated balloon, inhibiting then vision of some 'humble God' behind such balloon. The God is one of humility and therefore small and sort of hiding behind that big Ego-balloon; it's up to us to deflate that Ego-balloon so that the God behind becomes visible and us able to communicate. That rule is the same for everyone: When EGO inflates, God becomes invisible behind that Ego-balloon, and when EGO deflates, the God behind that Ego-balloon becomes visible and communicative.

The rules of clearing sins of others is bound to some universal laws. Yes, one can through one's own suffering clear some sins of others, but not in the way the Christian belief wants us to believe that by Jesus Christ's crucifixion all man- and human kind is 'redeemed' for thousands of years to come. Belief will not make it that way; even if billions of human beings

may belief and wish it to be that way. But religion in itself isn't futile. Initially, of course, religion can provide a lot of hope and stability to people in the often adverse circumstances of Earthly life. Beyond, religion can be a fitting INTRODUCTION to concepts and thoughts that aid in one's later self-development in a sense like pre- and primary schools can be a fitting foundation for later high school and university studies.

Futile, though, is turning religion and blind belief systems into 'opium for the people'. That is and never has been the purpose of religion; such belief systems simply are making people blind and stupid.

The real purpose of religion, and in such context every religion in the Universe, is meant to introduce people, like a human pre- and primary school, to basic concepts of understanding. But all too often religion fails in this venture, because people want miracles, redemption and heart warming rituals served to them on a silver plate. Self-effort, in all cases, is a necessity, and no one will find redemption without self-effort. There is no God up there that punishes and rewards, like in earthly judiciary systems, as we are the Gods ourselves to reap as we have sowed through our actions (karma). The harvest then is dual action-consequence. If anyone punishes us, it is us who punish ourselves by planning our visit to Earth in such ways. As human beings we are mind-confused and know nothing about our true standing in this Universe; but as Gods we certainly know and will plan and act accordingly. So, believe in someone else, a so-called saviour, that comes out from the heavens to save you without the least self-effort from your side, if you may wish to believe so. Such ill conceived belief will prove itself fatal, when you finally stand face to face with yourself, the God within you. Rather than clinging to wishful blind belief systems, awaken the God within you by humility and communication so that you'll receive appropriate guidance to all your ventures here on Earth and know in all clarity of mind, why you are here and what to accomplish you came here to.

**END OF PART III**

**SPACE FOR YOUR HANDWRITTEN NOTES TO PART III**

# EPILOGUE



# Epilogue

Here goes the Book of Ultimate Wisdom. Wisdom, in itself, is not the end. Wisdom is just a MEANS TO AN END, but not the end itself! And so is the legendary Philosopher's Stone!

Then WHAT is the 'End'?

The 'End' rests BEYOND all wisdom, understanding and reasoning. If we cling to wisdom, understanding, reasoning and even things like the so valuable Philosopher's Stone, we will reach 'somewhere', but not 'everywhere'. By clinging to anything we bind ourselves.

So, please, use this Book of Ultimate Wisdom TOWARDS an end and not as the end itself, will you?

This Book of Ultimate Wisdom is like a guide through a vast desert or across a huge ocean. Knowledge is needed for orientation and wisdom for appropriate application of such knowledge. Once one has reached, one can let go of what helped one to reach; but, certainly, not too early, as then one might get lost again, and certainly not too late, as then one might get stuck and not reach the ultimate goal, as the sand clock of life on Earth may run out! One needs to reach before life is over; otherwise one might have to start the journey all over again.

Good bye to all our friends that could use this Book of Ultimate Wisdom towards reaching somewhere close to Everything. For the final steps on your long journey we bid you now farewell and hope you enjoyed 'traveling' with us.

Good bye!

Yours truly,  
Team O°chelle

## A U T H O R S ' N O T E

This Book of Ultimate Wisdom is, on purpose, not bound by a Copyright to any individual or group. It is given free of charge to everyone. You are free to copy this book to your liking and share it with your friends and loved ones. But we would ask everyone **not** to make any changes, neither by interpretation nor by correction of perhaps grammatical and typographical errors. In case of translations being made we would request that a copy of the English language original accompanies such translation to enable the reader to review the translation against the English language original irrespective of whether the reader speaks English or not.

In a world of widespread confusion the situation may arise that some power broker sees an opportunity to copyright this Book in one's own name and thus control its publication and circulation. Such attempt is not and will not be supported by the authors of this Book. Such attempt could perhaps be legal in a human system, but is outright fraud within the framework of Universal Law. We would like to request all Readers not to support such attempt.

Human legal systems employ government agencies and courts to enforce their laws, whereas Universal Law employs the forces of nature and ultimately reincarnation, in which the roles of two players could even be switched in another round in that justice can be administered. The one who kills with the sword will die by the sword, some Holy Scripture comments to that. Even the greatest and smartest power broker on Earth will finally find its retribution, as all is only temporary in our mind projected world. The choice is always yours and never say that you are innocent, when something drastic hits you or your loved ones. You sure were not innocent, but you may not have remembered anymore WHAT you are being punished for. The human law and justice can be evaded at times, but not so the Universal Law of Justice, which works automatic beyond anyone's control. You are your own judge in the finals, in Soul Consciousness and not necessarily in human or mind consciousness. Never forget that, when you set out in a mental framework of wanting to be 'super smart'. It may work in the short run, but for sure not in the long run. Please remember that.

Cordially yours,  
Team O°chelle

## **SPACE FOR YOUR HANDWRITTEN NOTES**